

Looking ahead,
going beyond expectations
Ahead > Beyond

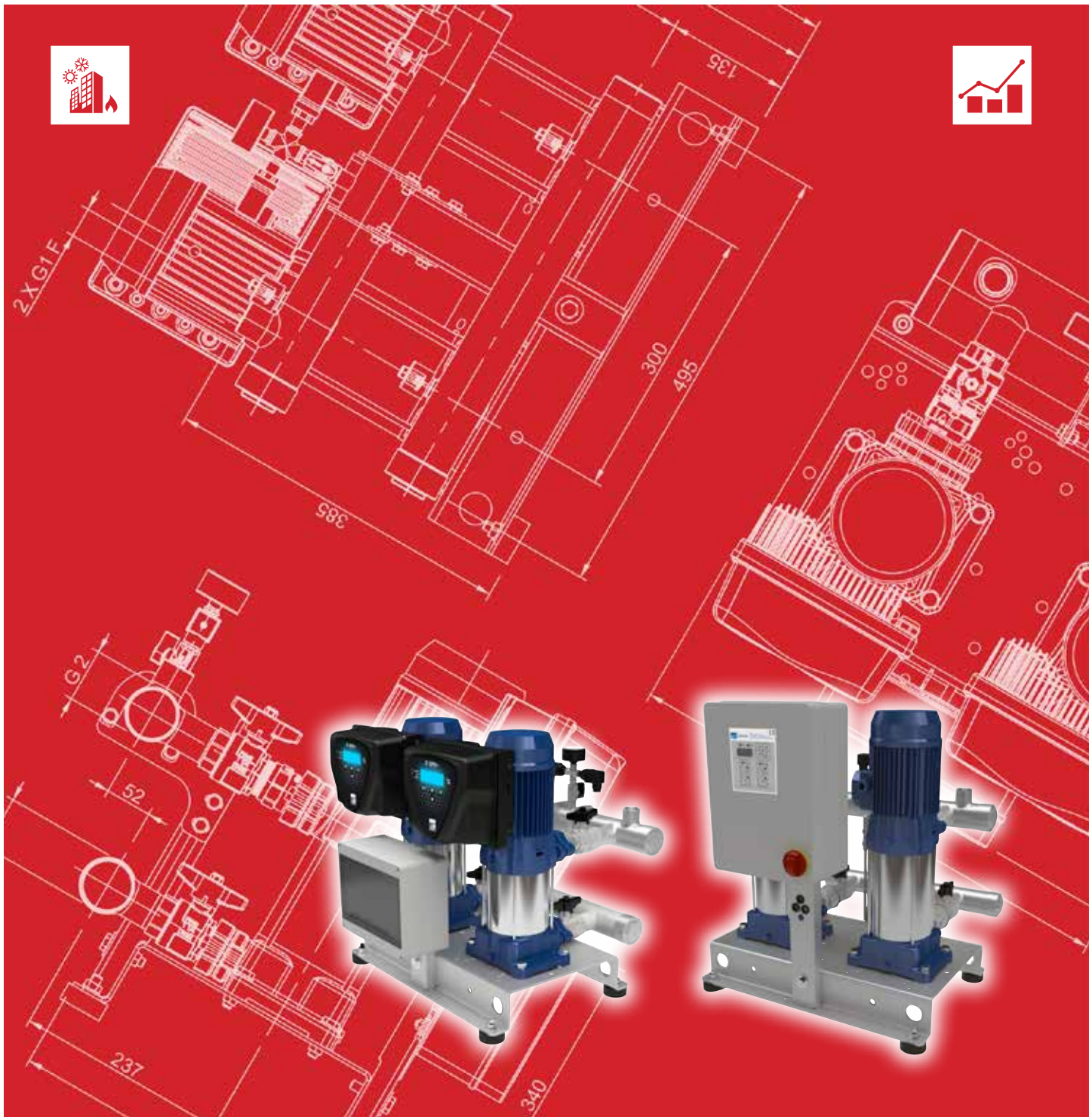

GP - GPE CVM

Data Book 50Hz



INDEX

	Page
INDEX	2
DEFINITION AND USE OF PRESSURISATION UNITS	101
TYPICAL APPLICATIONS	101
OPERATING CONDITIONS	101
TESTS AND TRIALS	101
MECHANICAL AND HYDRAULIC TESTS	101
ELECTRICAL TESTS	102
PRINCIPLE OF OPERATION OF GP PRESSURISATION UNITS	102
Principle of Operation of GPE Pressurisation UNITS with E-SPD+	102
Principle of Operation of GPE Pressurisation UNITS with an EFC control panel	102
Principle of Operation of GPE Pressurisation UNITS with an MFC control panel	103
Fig. 1 - TWO PUMP UNIT WITH CONSTANT PRESSURE REGULATION	104
GP PRESSURISATION UNIT WATER CIRCUIT DIAGRAM	104
GPE PRESSURISATION UNIT WATER CIRCUIT DIAGRAM	105
TYPE KEY	106
NAME PLATE	106
PRODUCT SPECIFICATIONS	201
HYDRAULIC COMPONENTS AND CONTROL	201
ELECTRIC PANEL	202
TECHNICAL PUMP DATA	203
TECHNICAL MOTOR DATA	204
PERFORMANCE RANGE	301
RESEAU BOOSTER SET 2GP(.) CVM	301
CURVE SPECIFICATION 2GP(.)	401
SELECTION CHART 2GP(.) CVM A-B	402
PERFORMANCE CURVE 2GP(.)	403
2GP(.) CVM A/8	403
2GP(.) CVM A/10	404
2GP(.) CVM A/12	405
2GP(.) CVM A/15	406
2GP(.) CVM A/18	407
2GP(.) CVM B/10	408
2GP(.) CVM B/12	409
2GP(.) CVM B/15	410
2GP(.) CVM B/20	411
2GP(.) CVM B/23	412

2GP(.) CVM B/25	413
2GP CONSTRUCTION	601
EXTERNAL VIEW 2GP CVM	601
2GPE CONSTRUCTION	602
EXTERNAL VIEW 2GPE CVM E-SPD+	602
OVERALL DIMENSIONS 2GP BOOSTER SET	603
2GP CVM	603
OVERALL DIMENSIONS 2GPE BOOSTER SET	604
2GPE CVM E-SPD+	604
PACKING	605
2GP(E) CVM	605
CONTROL PANEL FIXED SPEED	801
2EP-E SPECIFICATION	801
CONTROL PANEL VARIABLE SPEED	803
E-SPD+ SPECIFICATION	803
SP (EFC and MFC) SPECIFICATION	804
PROTECTION PANEL SPECIFICATION	807

DEFINITION AND USE OF PRESSURISATION UNITS

In situations in which a municipal water mains is lacking or insufficient for the proper operation of the services, one must install a pressurization unit to provide acceptable pressure and flow rates to even in the most unfavourable services. Pressurisation units are used wherever there is a need to increase the pressure, or to pressurise a water circuit. **EBARA GP pressurisation units** are automatic systems with 2 or more pumps operating in parallel, designed to provide a simple and reliable solution to the most common requirements for maintenance of water supply pressure for apartment buildings, hotels, centres, offices and schools as well as providing auxiliary service in industrial and agricultural applications. They stand out for their robust construction, compact size, excellent efficiency and silent operation. GP units are equipped for connection to membrane and air cushion autoclaves. They are controlled by pressure transmitter for EP-E and by pressure switches for EP. GPE units (with INVERTER) are controlled by pressure transmitter.

TYPICAL APPLICATIONS

INDUSTRY	BUILDING SERVICE	WATER SUPPLY
		

OPERATING CONDITIONS

EBARA GP-GPE pressurisation units can be used, in their standard versions, for civil, industrial and agricultural applications, as follows:

- building service
- water lifting and handling
- A/C
- heating
- irrigation
- washing systems

The conveyed fluid must be: clean, potable, ground or mixed water, free of solid or fibrous suspensions and aggressive chemical substances.

The units must be installed under cover, protected from the weather and freezing.

- Conveyed water temperature (depending on pumps).
- Ambient operating temperature 0 - 40°C, no higher than 1000 m above sea level.
- Max relative humidity 50% at +40°C.

NB: The system available NPSH must be greater than the NPSH demanded from the pump. For applications with different technical specifications, uses and climatic conditions (type of vector fluid, marine and aggressive industrial conditions), please contact our sales network.

TESTS AND TRIALS

Before shipping, all EBARA pressurisation units are subject to hydraulic, mechanical and electrical testing.

MECHANICAL AND HYDRAULIC TESTS

- Pressure switch calibration 8 only if present)
- Pump direction of rotation
- Mechanical testing of moving parts and running noise (on each pump)
- Tightness test with delivery port closed and nameplate rating tests
- MANUAL trials (using button on control panel) for each pump
- AUTOMATIC trials (using switch on control panel) for unit

ELECTRICAL TESTS

- Earthing system continuity
- Applied voltage (dielectric rigidity)
- Insulation resistance

PRINCIPLE OF OPERATION OF GP PRESSURISATION UNITS

When water is demanded, it is first drawn from the autoclave tank (if present). This demand for water, with the pumps stopped, lowers the pressure until the first pressure switch (for EP version) or the pressure transmitter (for EP-E version) starts the first electropump. If the output flow is greater than the delivery capacity of a single pump, the pressure continues falling until the second pressure switch (for EP version) or the pressure transmitter (for EP-E version), thus starting the second pump. This happens for all pumps in the unit. When the water demand stops or reduces, the system pressure rises, the pressure switches (for EP version) or the pressure transmitter (for EP-E version) shutting off the pumps one by one. This is done in inverse order to that in which the motors were started up, the number of hourly starts per pump is reduced and they are all used to the same extent.

NB: By connecting a float switch or minimum pressure switch to the control panel (both for demand from the first accumulation tank and from the water circuit itself) one can prevent the most frequent cause of pump failure: dry running

Principle of Operation of GPE Pressurisation UNITS with E-SPD+

GPE units with E-SPD+ are designed to operate with each pumps controlled by an INVERTER installed on board its motor. The system is controlled by an MASTER INVERTER in relation to the reference signal supply by a pressure transmitters (4 - 20 mA passive). As the system pressure varies, the MASTER pump varies its rotary speed to restore it to the setpoint. If the water demand exceeds the capacity of the pump, the second variable speed pump cuts in and, pump goes into regulation mode to maintain the pressure setpoint; this happens for all the pumps in the unit. If the water demand drops off, the pressure tends to increase and the latest pump gradually reduces its speed to restore the correct operating pressure. This results in the regulation of the speed of the other pumps, until they gradually turn off. Once the system pressure has been restored and the water demand is 0, the MASTER pump switches off automatically.

Principle of Operation of GPE Pressurisation UNITS with an EFC control panel

EFC multiple pump control units power pump n. 1 with the INVERTER to modulate system performance in relation to the reference signal while the other pumps are run at maximum nominal speed (around 2900 rpm) and started and stopped in relation to demand.

These means there are two distinct primary electrical circuits:

- n. 1 - INVERTER startup/control of a single pump,
- n. 2 - contactor startup (direct or star/delta) of the other pumps.

The system is controlled by an electronic controller in relation to the reference signal supply by a pressure transmitter, flow meter or other unified control signal (4 - 20 mA passive).

If the electronic controller or pressure transmitter fails, a system of pressure switches controls the pumps directly (if present).

- In case of water distribution at constant pressure (Fig.1), the electronic controller is connected to the pressure transmitter on the units' delivery manifold, which outputs a signal proportional to the circuit pressure. When the pressure drops due to water demand, the pressure transmitter signal also drops and the controller starts and controls the speed of the first pump with the INVERTER to restore the reference/ operating pressure. If the pump's flow rate is lower than demand, the circuit pressure will continue to drop and the system responds by increasing the pump's speed. Once pump n. 1 reaches its maximum speed and demand is still in excess of its delivery, the controller will start pump n. 2 at maximum speed. The speed of pump n. 1 is immediately modulated so as to establish the operating pressure. If the pressure drops even further and pump n. 1 is once again running at maximum speed, the controller starts up pump n. 3, and so on for all pumps in the unit. If the water demand drops off, the pressure tends to increase and the controller reduces the speed of pump n. 1 to restore the correct operating pressure. At this point, the controller will stop one of the pumps running at

maximum speed, while the speed of pump n. 1 is modulated to maintain the reference pressure. As the pressure continues to increase due to reduced demand, once the minimum speed of pump n. 1 is reached once more the controller will stop pump n. 3 and then pump n. 2. Once the demand for water has completely ceased, the controller reduces the speed of pump n. 1 to its minimum and after a set delay (around 1 minute) stops this pump too. The next time the system is started up, the INVERTER controlled pump will no longer be pump n. 1, but n. 2. The INVERTER controlled pump thus rotates through all pumps in sequence.

Principle of Operation of GPE Pressurisation UNITS with an MFC control panel

MFC multiple pump control panels power each pump with an INVERTER to modulate system performance in relation to the reference signal. MFC controllers differ from EFC controller from the point of view of their construction, since instead of having a single INVERTER to control all the pumps, each pump has its own INVERTER. The two types of control panel differ in construction, but they have the same type of operation by the controller, which responds to the reference signal output by a pressure transmitter or other unified control (4 - 20 mA passive). If the electronic controller or pressure transmitter fails, a system of pressure switches controls the INVERTERS directly.

- In case of water distribution at constant starting pressure (Fig.1), the electronic controller is connected to the pressure transmitter on the units' delivery manifold, which outputs a signal proportional to the circuit pressure. When the pressure drops due to water demand, the pressure transmitter signal also drops and the controller starts and controls the speed of the first pump with the INVERTER to restore the reference/ operating pressure. If the pump's flow rate is lower than demand, the circuit pressure will continue to drop and the system responds by increasing the pump's speed. Once pump n. 1 reaches its maximum speed and demand is still in excess of its delivery, the controller will start pump n. 2, also at variable synchronous speed. The controller will modulate the speed of the two pumps to restore the operating pressure; the modulating frequency is the same for both pumps. If the pressure drops even further and pumps n. 1 and 2 are once again running at maximum speed, the controller starts up pump n. 3, and then pump n. 4, if present. When the water demand is reduced the pressure will end to increase, as does the pressure transmitter output value. The controller thus reduces the speed of pumps n. 1, 2, 3 and 4 (they are all controlled at the same speed) to restore the reference/ operating pressure. If the pumps' flow rate is greater than demand, the circuit pressure will continue to increase and the system responds by decreasing the speed of the pumps until it reaches the minimum speed setting. At this point, the controller will stop pump n. 4, while the speed of pumps n. 1, 2 and 3 is modulated to maintain the reference pressure. As the pressure continues to increase due to reduced demand, once the minimum speed setting is reached again, the controller will stop pump n. 3 and modulate the speed of pumps n. 1 and 2. This continues in sequence as the demand continues to fall, until the unit is completely stopped.

Fig. 1 - TWO PUMP UNIT WITH CONSTANT PRESSURE REGULATION

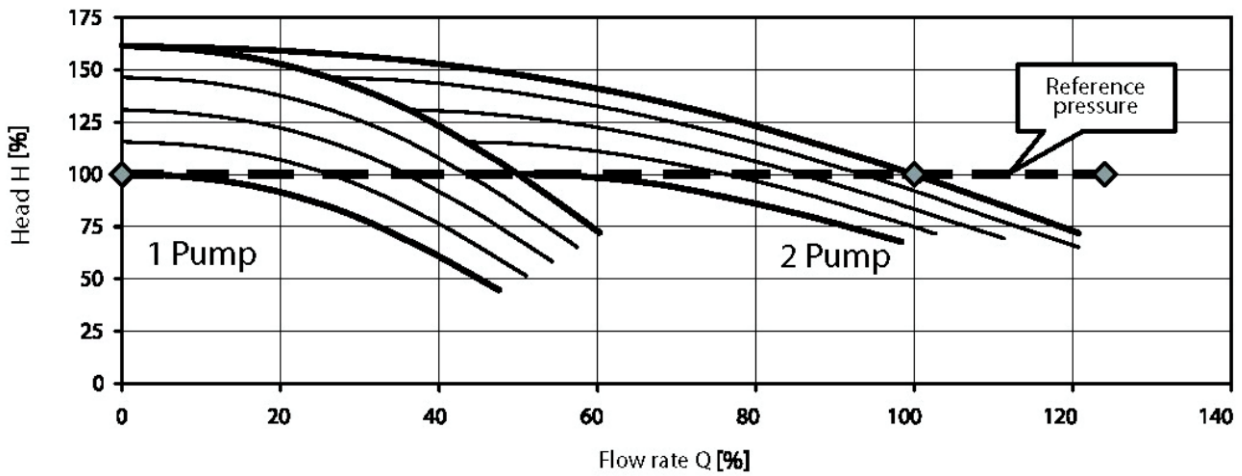

GP PRESSURISATION UNIT WATER CIRCUIT DIAGRAM

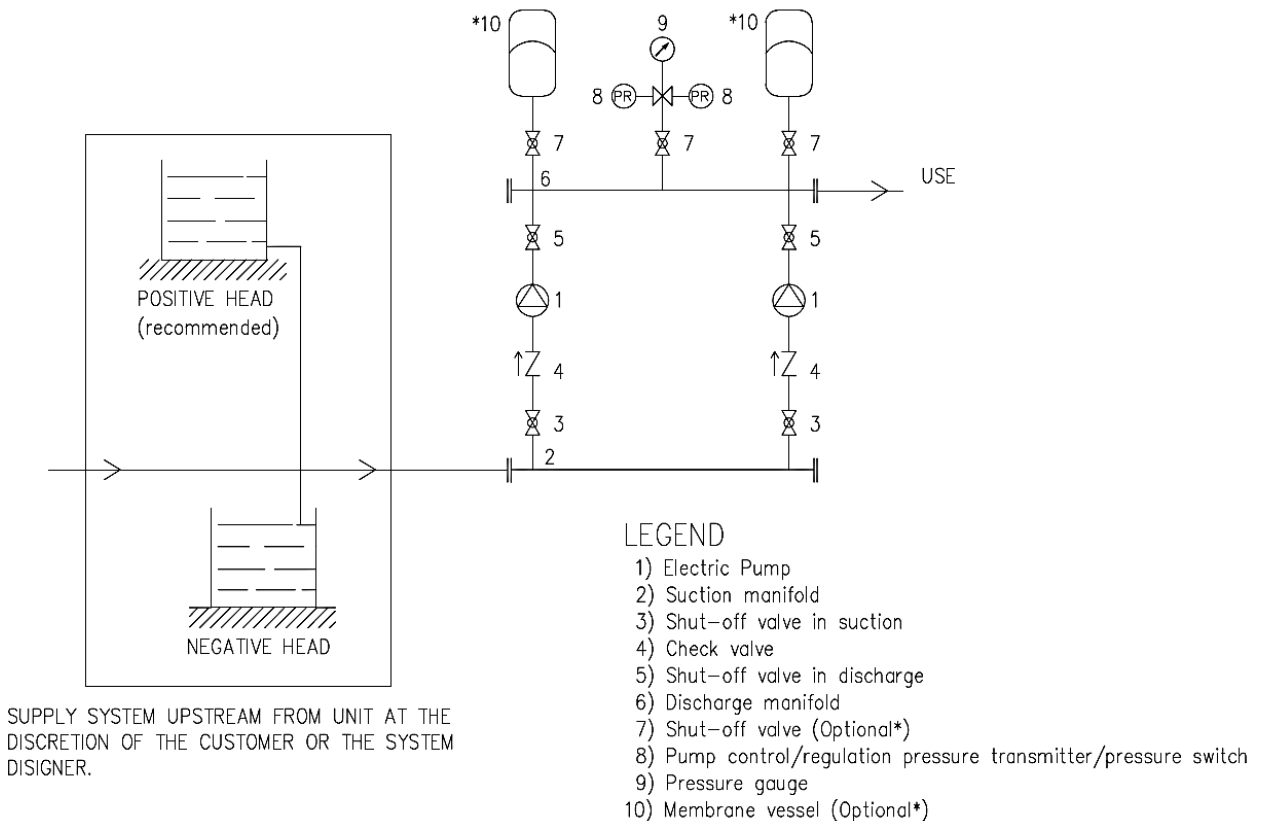

GPE PRESSURISATION UNIT WATER CIRCUIT DIAGRAM

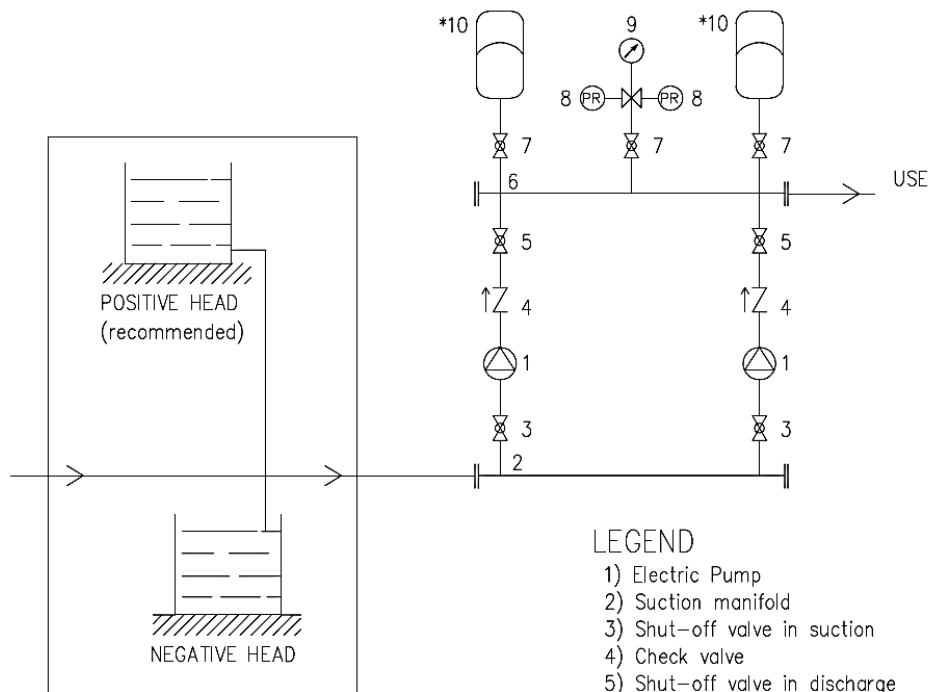

SUPPLY SYSTEM UPSTREAM FROM UNIT AT THE DISCRETION OF THE CUSTOMER OR THE SYSTEM DESIGNER.

LEGEND

- 1) Electric Pump
- 2) Suction manifold
- 3) Shut-off valve in suction
- 4) Check valve
- 5) Shut-off valve in discharge
- 6) Discharge manifold
- 7) Shut-off valve (Optional*)
- 8) Pump control/regulation pressure transmitter/pressure switch
- 9) Pressure gauge
- 10) Membrane vessel (Optional*)

TYPE KEY

2GP(.) CVM

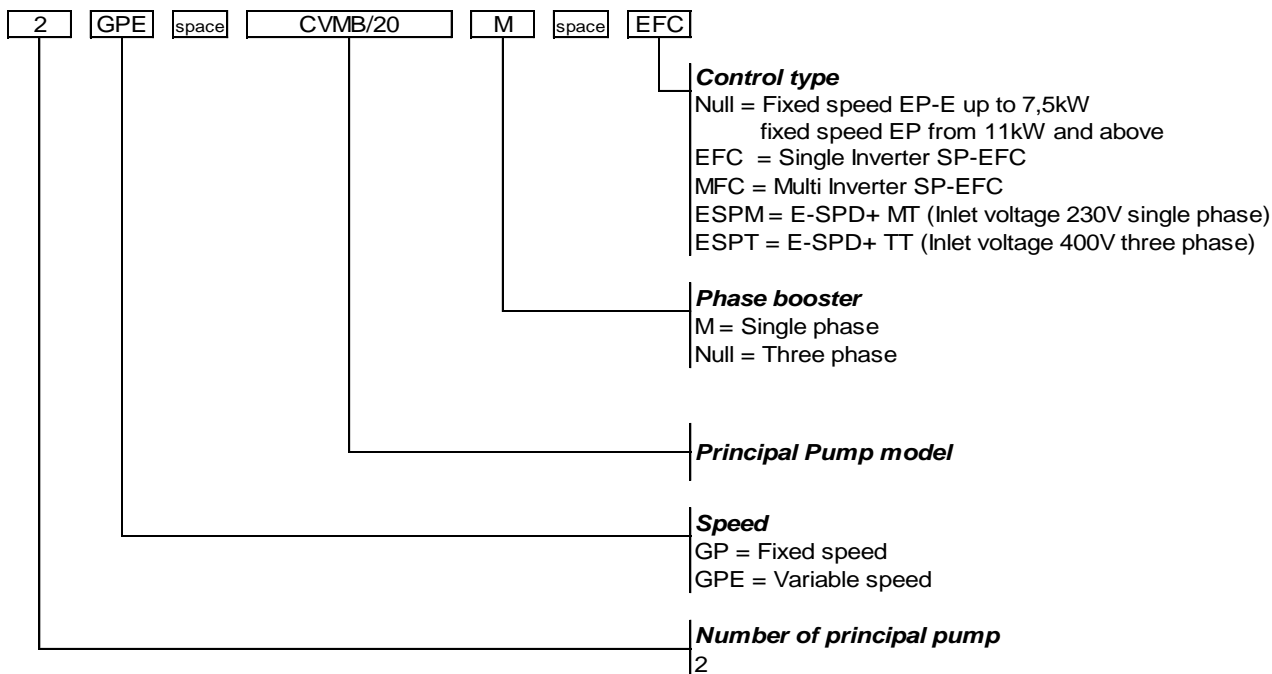

NAME PLATE

	EBARA Pumps Europe S.p.A. Via Campo Sportivo, 30 38023 Cles (TN), ITALY Phone +39 0444 706811 V.A.T.: 01234660221	  
	MADE IN ITALY	
GRUPPO DI PRESSURIZZAZIONE IDRICA		
TYPE	①	
P/N	②	
S/N	③	

- 1) "TYPE" booster model
- 2) "P/N" booster item number
- 3) "S/N" booster serial number

PRODUCT SPECIFICATIONS HYDRAULIC COMPONENTS AND CONTROL

BOOSTER SET				
CVM				
Operating range	Version		A	B
	Nominal flow rate (m ³ /h)	Single pump	4.8	7.2
		2GP(E)	9.6	14.4
	Maximum working pressure		11 bar	
	Liquid temperature range		+5 ÷ +40°C	
	Ambient operating temperature (no higher than 1000 m above sea level)		0÷40°C	
Hydraulic components	Frame		Omega sheet Galvanized steel	
	Manifold suction / discharge		Threaded manifold AISI 304	
	Closing manifold		Threaded female cap AISI 304	
	Check valve		Threaded check valve Brass / NBR	
	Ball valve		Threaded ball valve Brass / PTFE	
	Socket for air feeders (only for "GP" version)		Threaded socket Brass	
Control	Pressure gauge		M3A-ABS 50/FR / plastic-copper alloy	
	Pressure switches		Only for GPE version with SP EFC / MFC panel with inverter XMP / -25°C...+70°C	
	Pressure transmitter		GP version with EP-E panel fixed speed GPE version and with E-SPD+ EN 10088-1.4301 (AISI 304) / 1.4404 (AISI 316L)	

ELECTRIC PANEL

BOOSTER SET				
CVM				
Operating Range	Version		A	B
	Nominal flow rate (m ³ /h)	Single pump	4.8	7.2
		2GP(E)	9.6	14.4
Control panel	Principal Electric panel	EP-E fixed speed (only for GP)	●	●
		SP EFC/MFC variable speed (only for GPE)	○	○
	E-SPD+ (ESPM-ESPT) [1]	supply inverter (only for GPE)	●	●
		supply inverter (only for GPE)	●	●

● : Standard ○ : Optional

[1] To be assemble with protection panel (to see "PROTECTION PANEL" section)

TECHNICAL PUMP DATA

PUMP			
CVM			
Operating range	Version	A	B
	Maximum working pressure	1.1 MPa (11 bar)	
	Liquid temperature range	+5°C to +40°C	
Liquid handled	Liquid type	Clean water	
Key components material	Casing	Cast iron	
	Impeller	PPE+PS Glass fibre reinforced	
	Shaft seal	Ceramic/Carbon/NBR	
	Shaft	AISI 416	
	Bracket	Cast iron	
Pipe connection	Diffuser	PPE+PS Glass fibre reinforced	
	Suction	G 1" ¼ UNI ISO 228	
	Discharge		

TECHNICAL MOTOR DATA

MOTOR				
CVM				
Power source	Frequency	50 Hz		
	Phase	Single-phase	Three-phase	
	Rotation speed	2850 min-1		
	Power rating	0.6 ÷ 1.7 kW	0.6 ÷ 1.85 kW	
		0.8 ÷ 2.3 HP	0.8 ÷ 2.5 HP	
Voltage	230 ± 10% V	230/400 ± 10%		
Type	Type	Electric asynchronous - TEFC		
	Efficiency level	-	IE3	
	N° of poles	2		
	Protection degree	IP 44		
	Insulation class	F		
Others	Capacitor	Built in	-	
	Overload protection	Built in	Provided by the user	
	Casing Material	Aluminium		

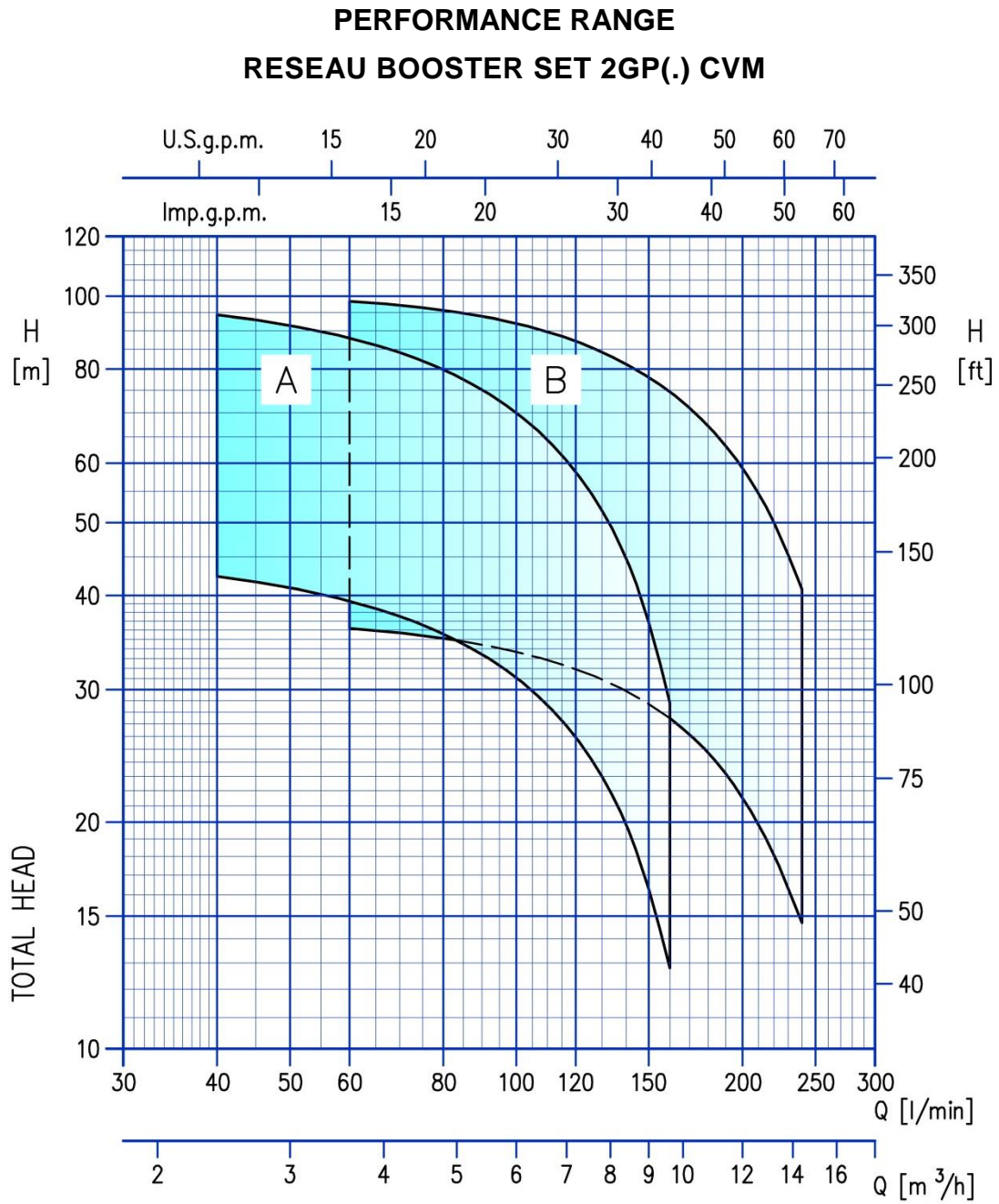

CURVE SPECIFICATION 2GP(.)

The specifications below qualify the curves shown on the following pages.

Tolerances according to ISO 9906:2012 – Grade 3B.

The curves refer to effective speed of asynchronous motors at 50 Hz 2 poles

Measurements were carried out with clean water at 20°C of temperature and with a kinematic viscosity of $\nu = 1 \text{ mm}^2/\text{s}$ (1 cSt).

The NPSH curve is an average curve obtained in the same conditions of performance curves.

During the pump selection, consider to get a safety margin of at least 0.5 m.

The continuous curves indicate the recommended working range. The dotted curve is only a guide.

In order to avoid the risk of over-heating, the pumps should not be used at a flow rate below 10% of best efficiency point. The performance curves refer to 2-pumps booster sets.

Symbols explanation:

- Q = volume flow rate
- H = total head
- P2 = pump power input (shaft power)
- η = pump efficiency
- NPSH = net positive suction head required by the pump
- 1 = one pump on work performance curve
- 2 = two pumps on work performance curve
- MEI = minimum efficiency index

Pressure drops of the booster's fittings are not considered

The minimum efficiency index (MEI) is a measure of the quality of a pump size respect to its mean efficiency. The minimum efficiency index is based on the hydraulic efficiency and on the head at the best efficiency point.

MEI = 0.4 for Multistage Vertical 2900rpm

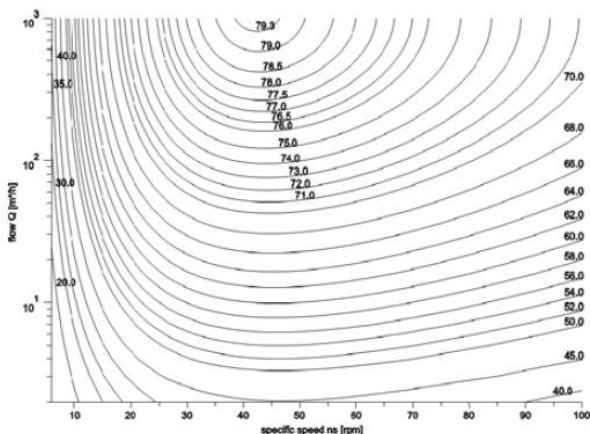

MEI=0.7 for Mutistage Vertical 2900 rpm

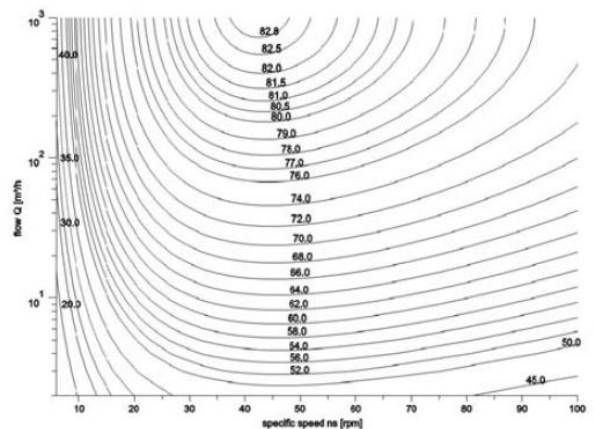

SELECTION CHART 2GP(.) CVM A-B

Model	Motor		Maximum working pressure (MPa)	Q=Capacity									
	kW	HP		l/min	40	60	80	100	120	160	200	240	
				m ³ /h	2.4	3.6	4.8	6.0	7.2	9.6	12.0	14.4	
				H=Total manometric head in meters									
2GP(.) CVM A/8	0.6+0.6	0.8+0.8	1.0	47.5	42.5	39.4	35.6	31.1	25.9	12.8	-	-	
2GP(.) CVM A/10	0.75+0.75	1+1		62.5	57.5	54.0	49.5	43.5	36.6	19.5	-	-	
2GP(.) CVM A/12	0.9+0.9	1.2+1.2		75.0	69.0	65.0	59.5	52.5	44.0	23.4	-	-	
2GP(.) CVM A/15	1.1+1.1	1.5+1.5		87.5	80.5	75.5	69.5	61.0	51.0	27.3	-	-	
2GP(.) CVM A/18	1.3+1.3	1.8+1.8		103.0	94.5	88.0	80.0	70.0	58.5	28.8	-	-	
2GP(.) CVM B/10	0.75+0.75	1+1		38.1	-	36.2	35.1	33.7	32.0	27.5	21.6	14.7	
2GP(.) CVM B/12	0.9+0.9	1.2+1.2		51.0	-	48.0	46.8	45.0	42.6	36.6	28.8	19.6	
2GP(.) CVM B/15	1.1+1.1	1.5+1.5		63.5	-	60.5	58.5	56.2	53.3	45.8	36.0	24.5	
2GP(.) CVM B/20	1.5+1.5	2+2		78.5	-	74.0	72.0	69.0	65.5	56.0	44.5	30.6	
2GP(.) CVM B/23	1.7+1.7	2.3+2.3		91.5	-	86.0	84.0	80.5	76.5	65.5	51.5	35.7	
2GP(.) CVM B/25	1.85+1.85	2.5+2.5		105.0	-	98.5	96.0	92.0	87.0	74.5	59.0	41.0	

PERFORMANCE CURVE 2GP(.) 2GP(.) CVM A/8

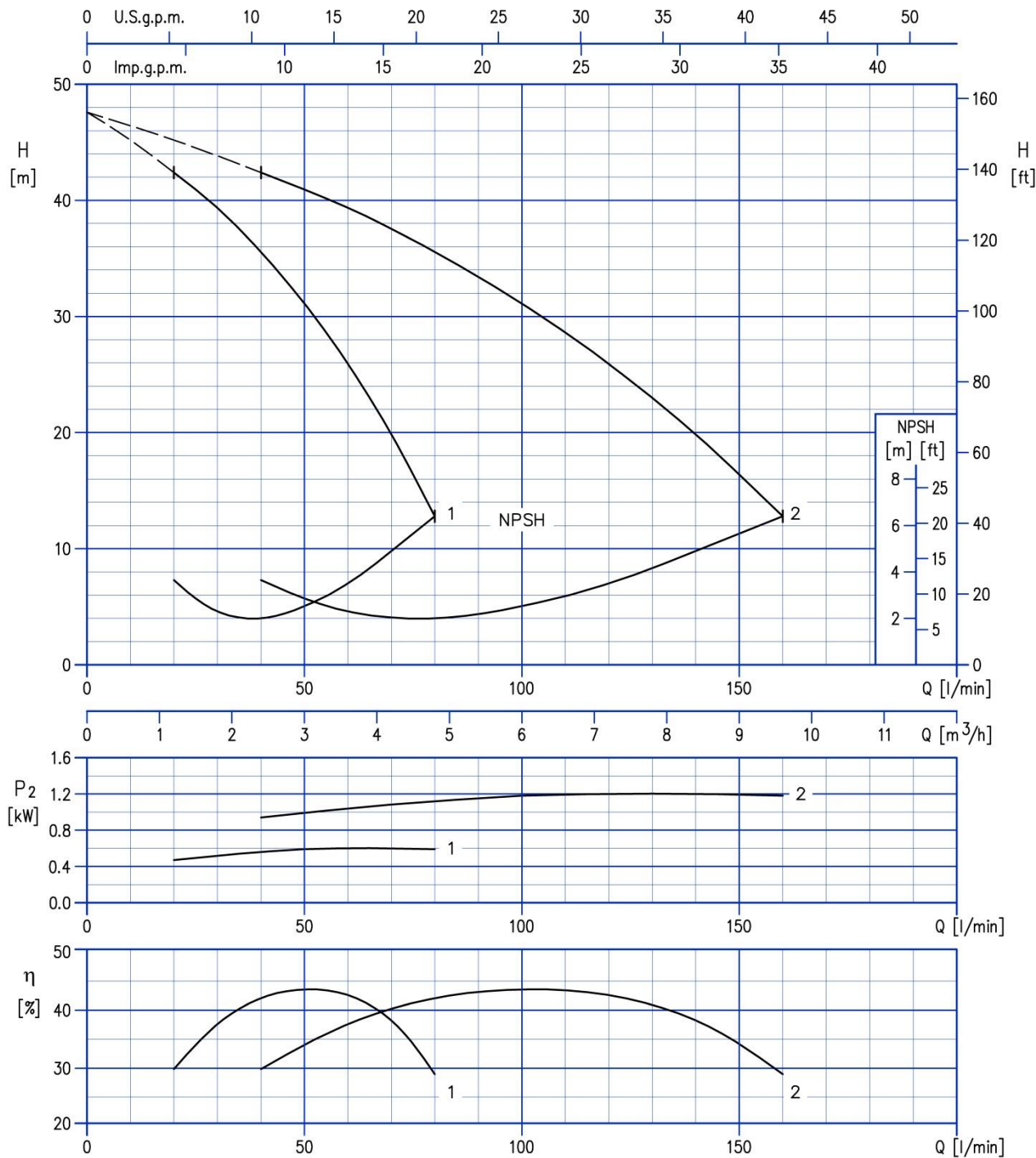

Test standard: ISO 9906: 2012 - Grade 3B

2GP(.) CVM A/10

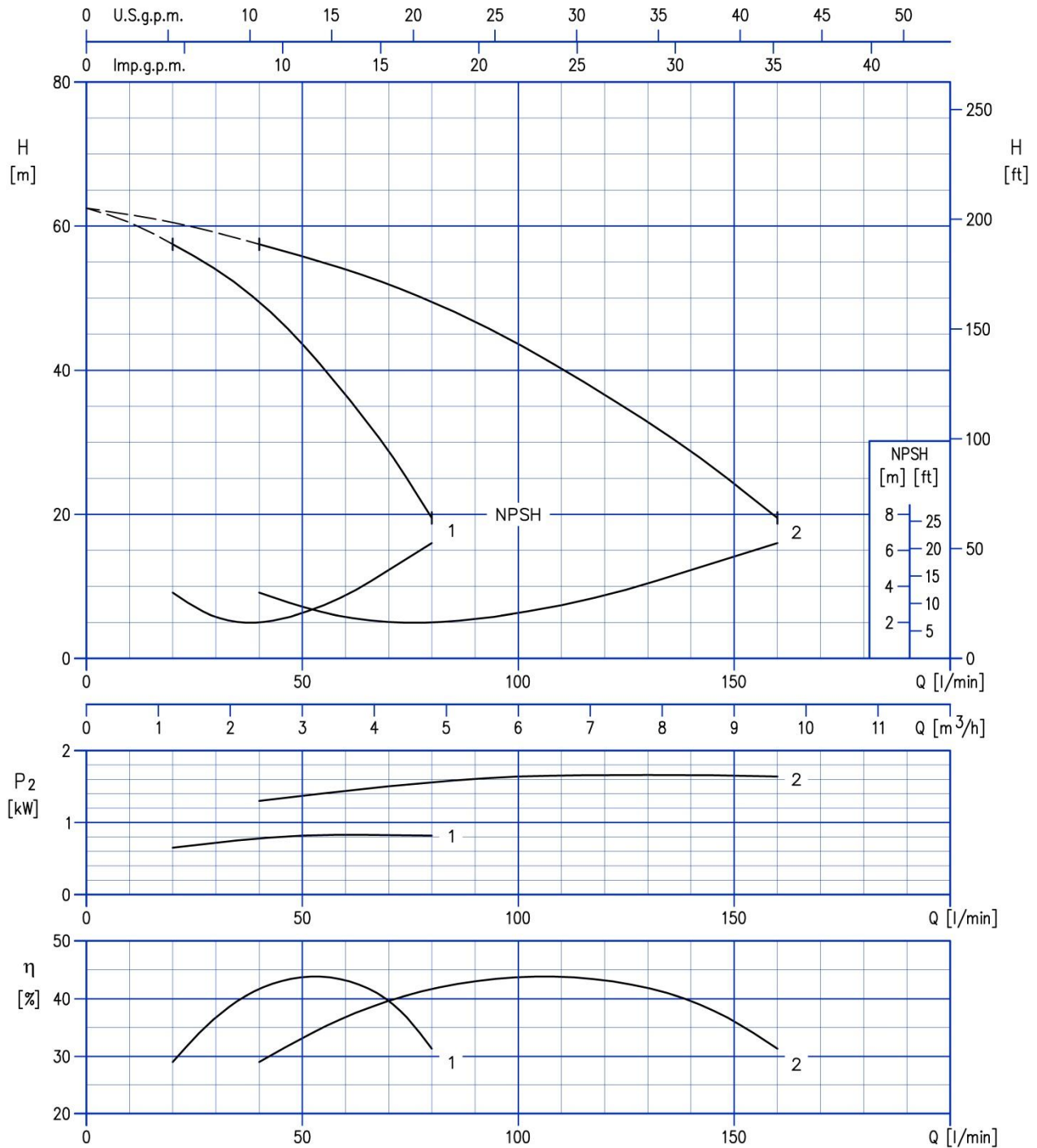

Test standard: ISO 9906: 2012 - Grade 3B

2GP(.) CVM A/12

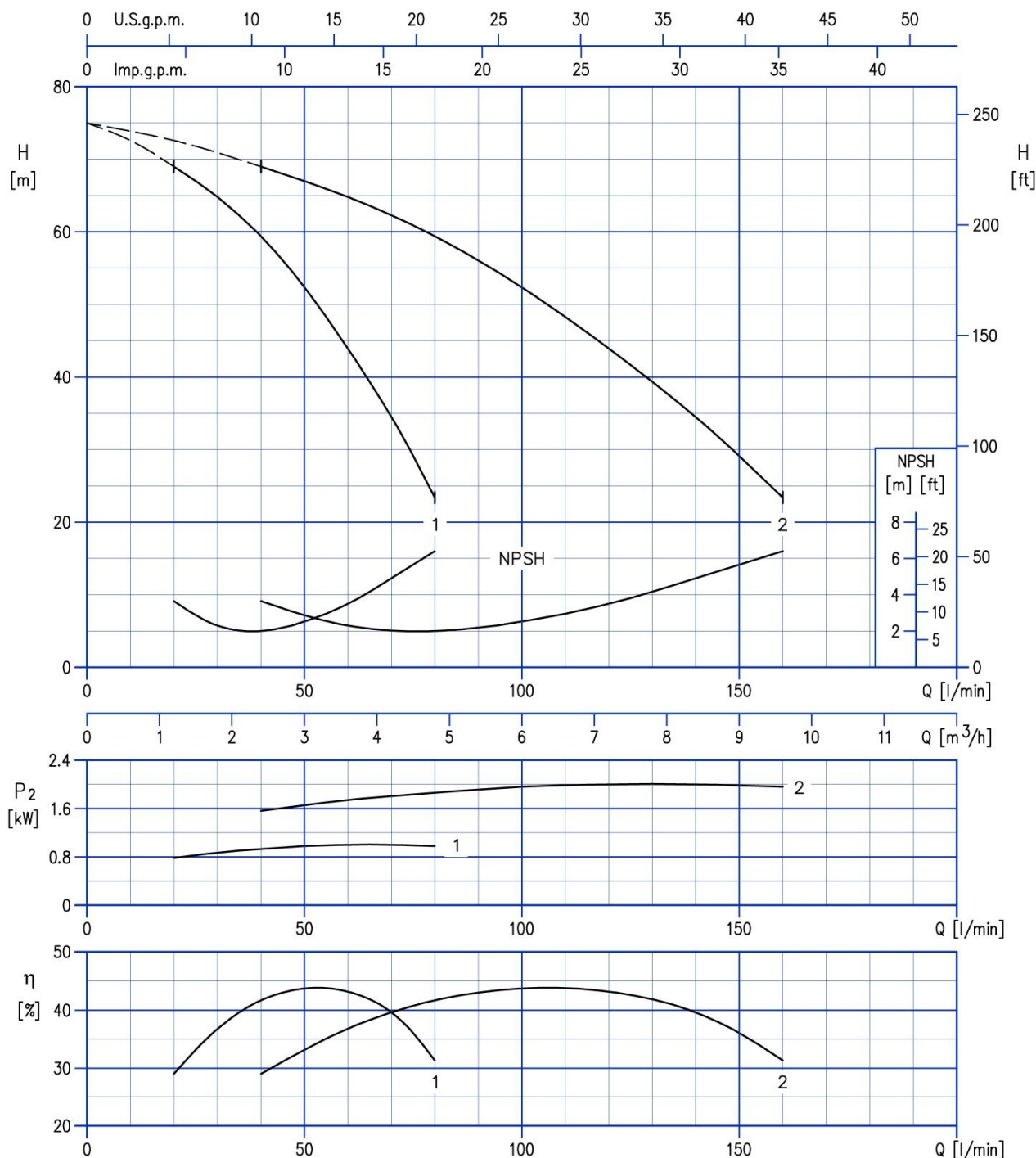

Test standard: ISO 9906: 2012 - Grade 3B

2GP(.) CVM A/15

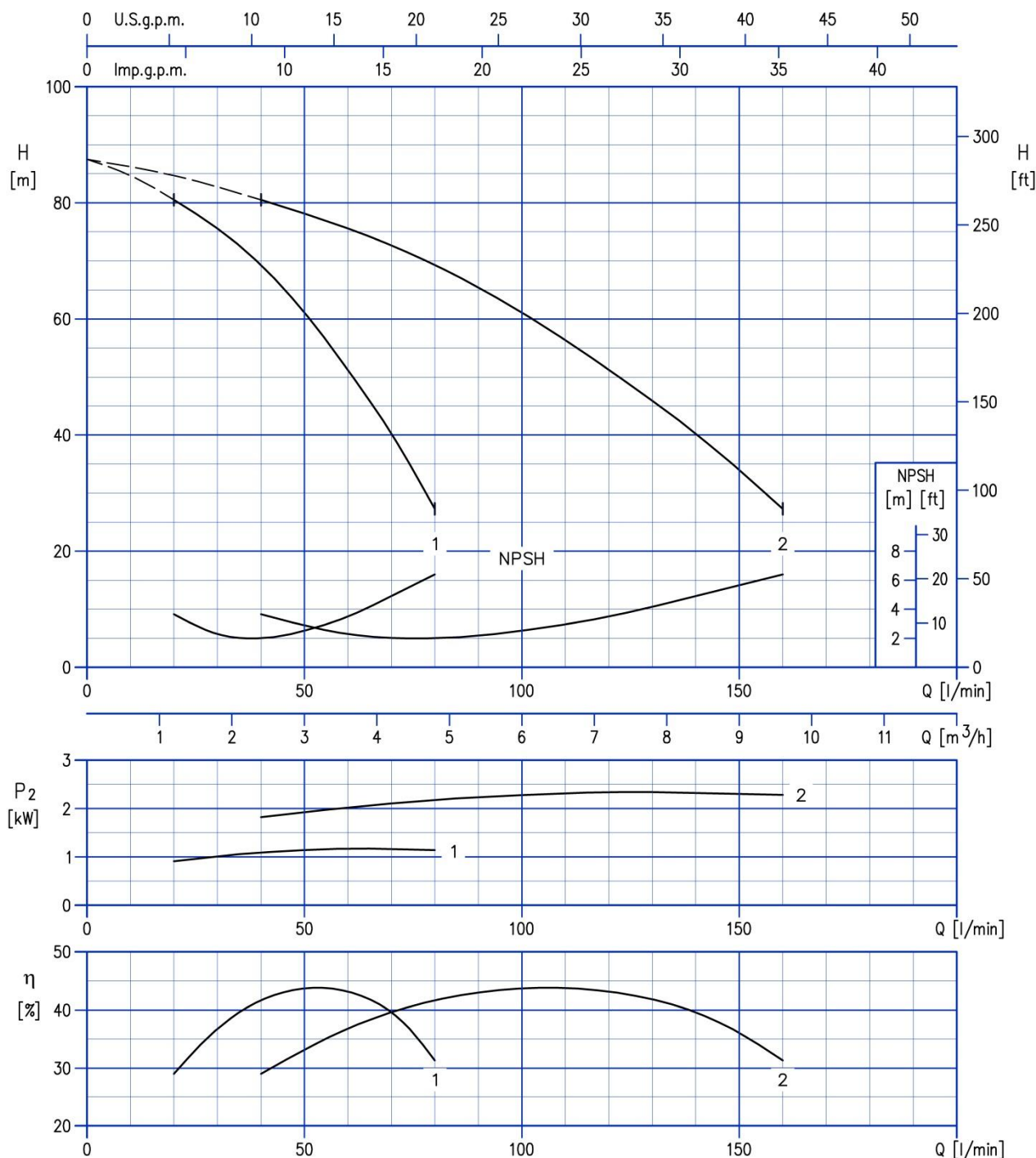

Test standard: ISO 9906: 2012 - Grade 3B

2GP(.) CVM A/18

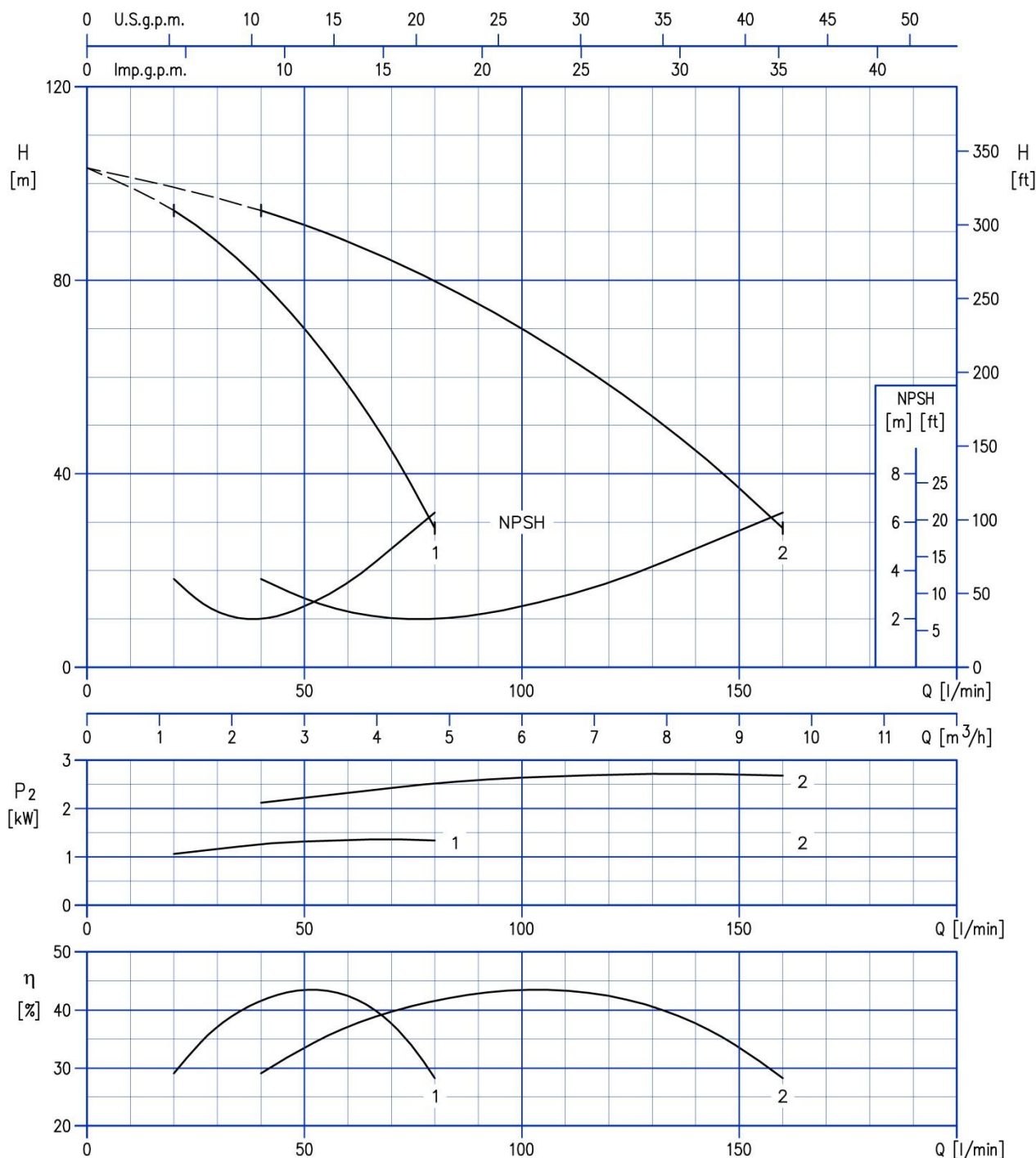

Test standard: ISO 9906: 2012 - Grade 3B

2GP(.) CVM B/10

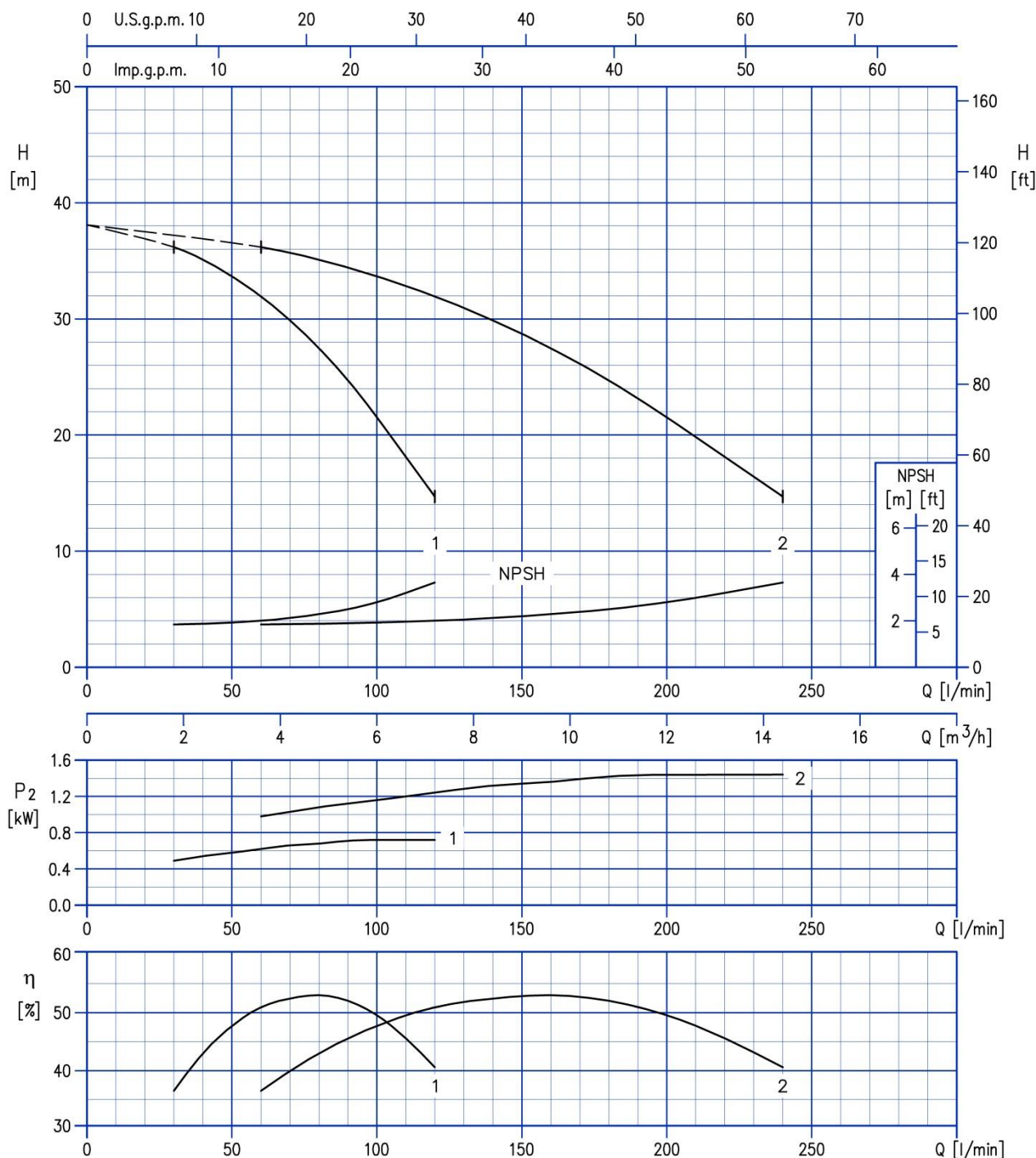

Test standard: ISO 9906: 2012 - Grade 3B

2GP(.) CVM B/12

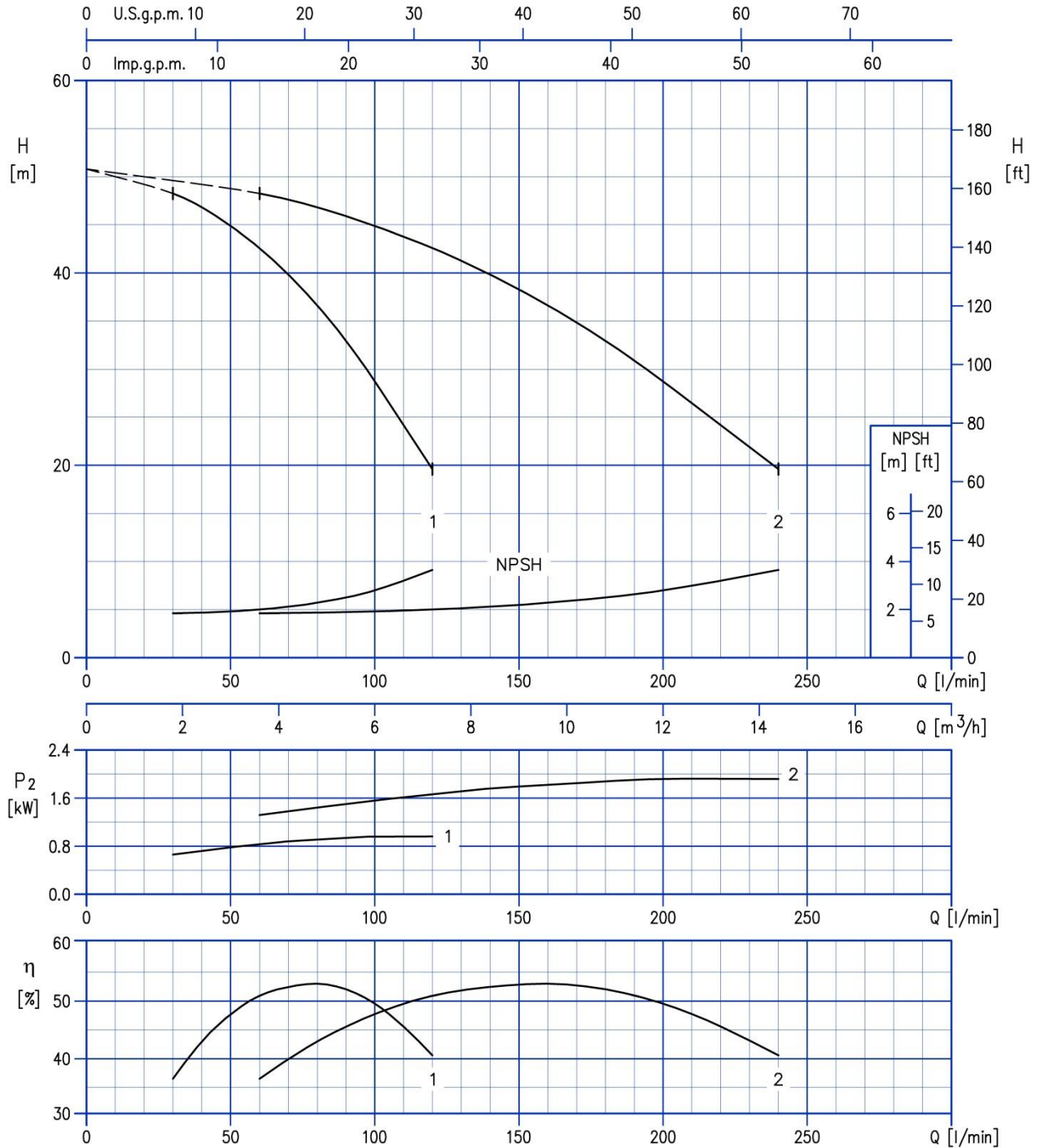

Test standard: ISO 9906: 2012 - Grade 3B

2GP(.) CVM B/15

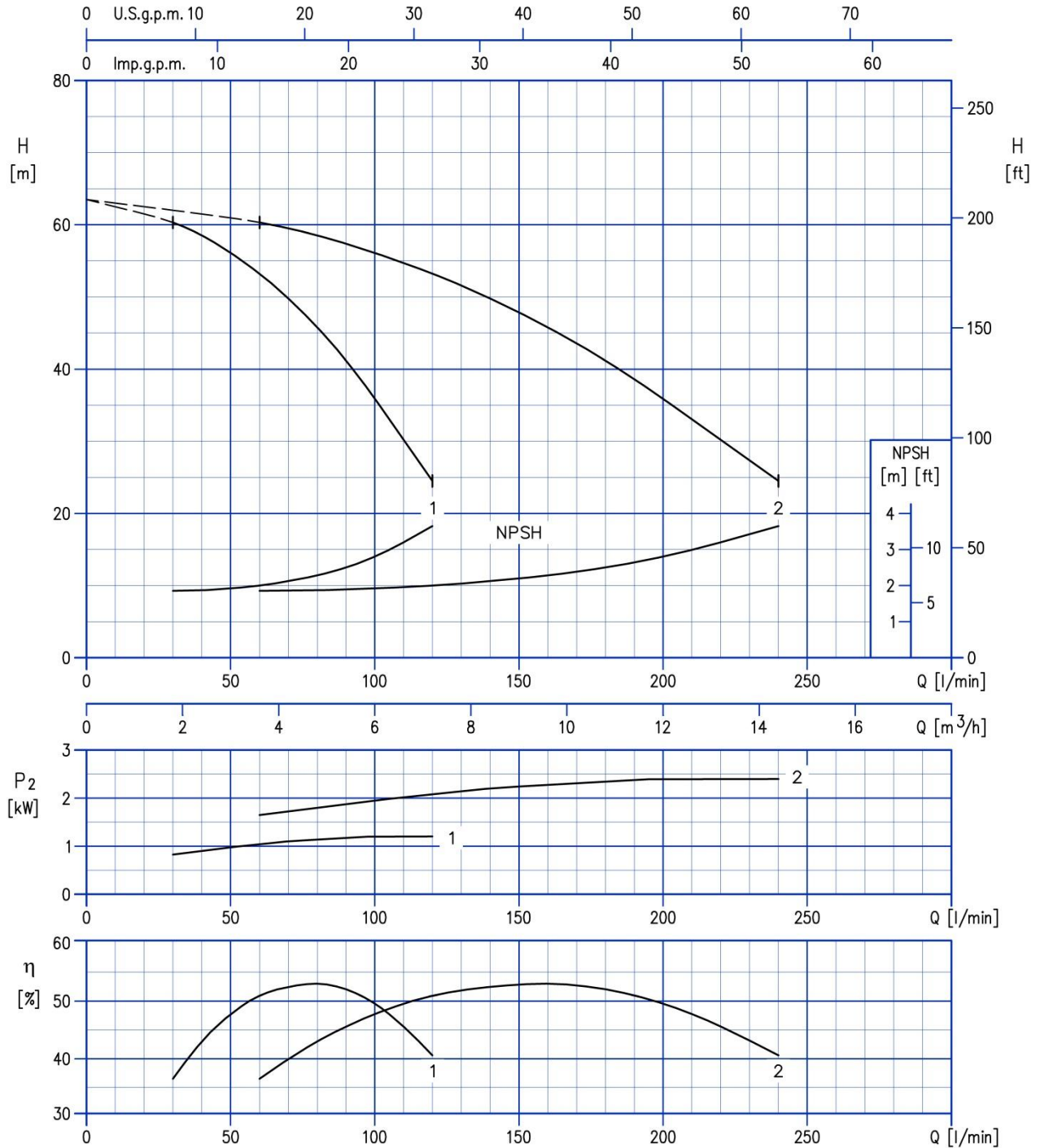

Test standard: ISO 9906: 2012 - Grade 3B

2GP(.) CVM B/20

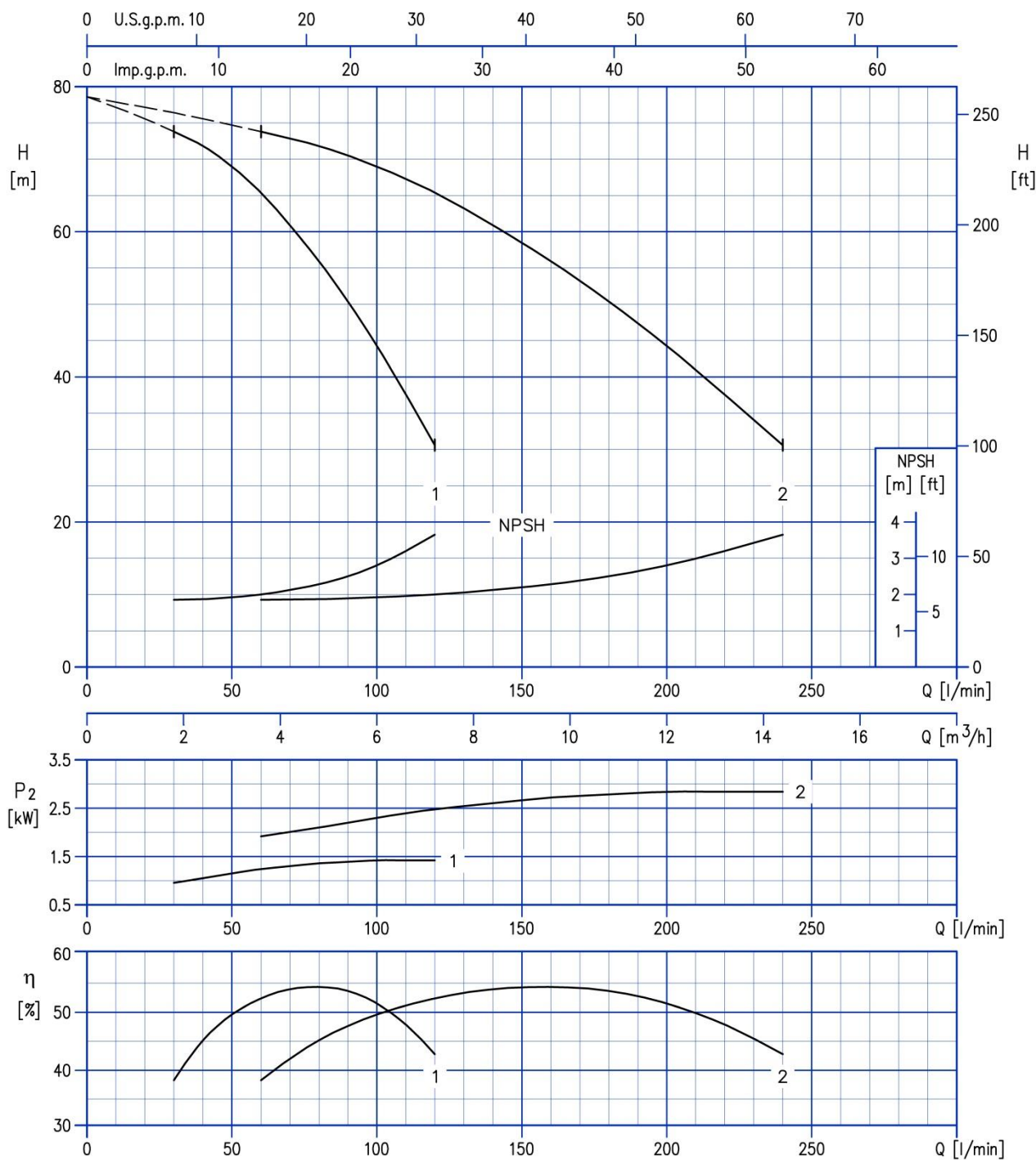

Test standard: ISO 9906: 2012 - Grade 3B

2GP(.) CVM B/23

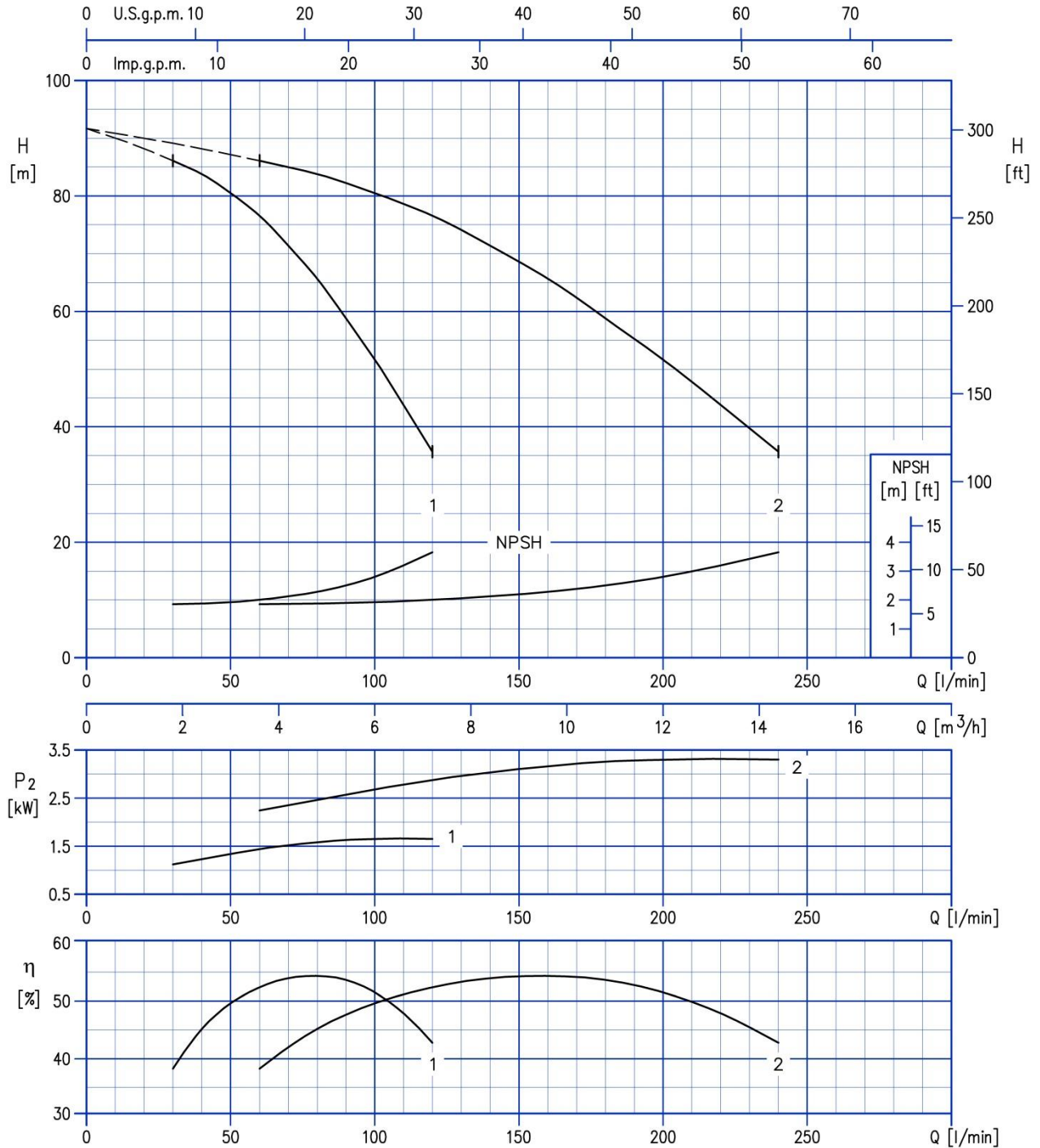

Test standard: ISO 9906: 2012 - Grade 3B

2GP(.) CVM B/25

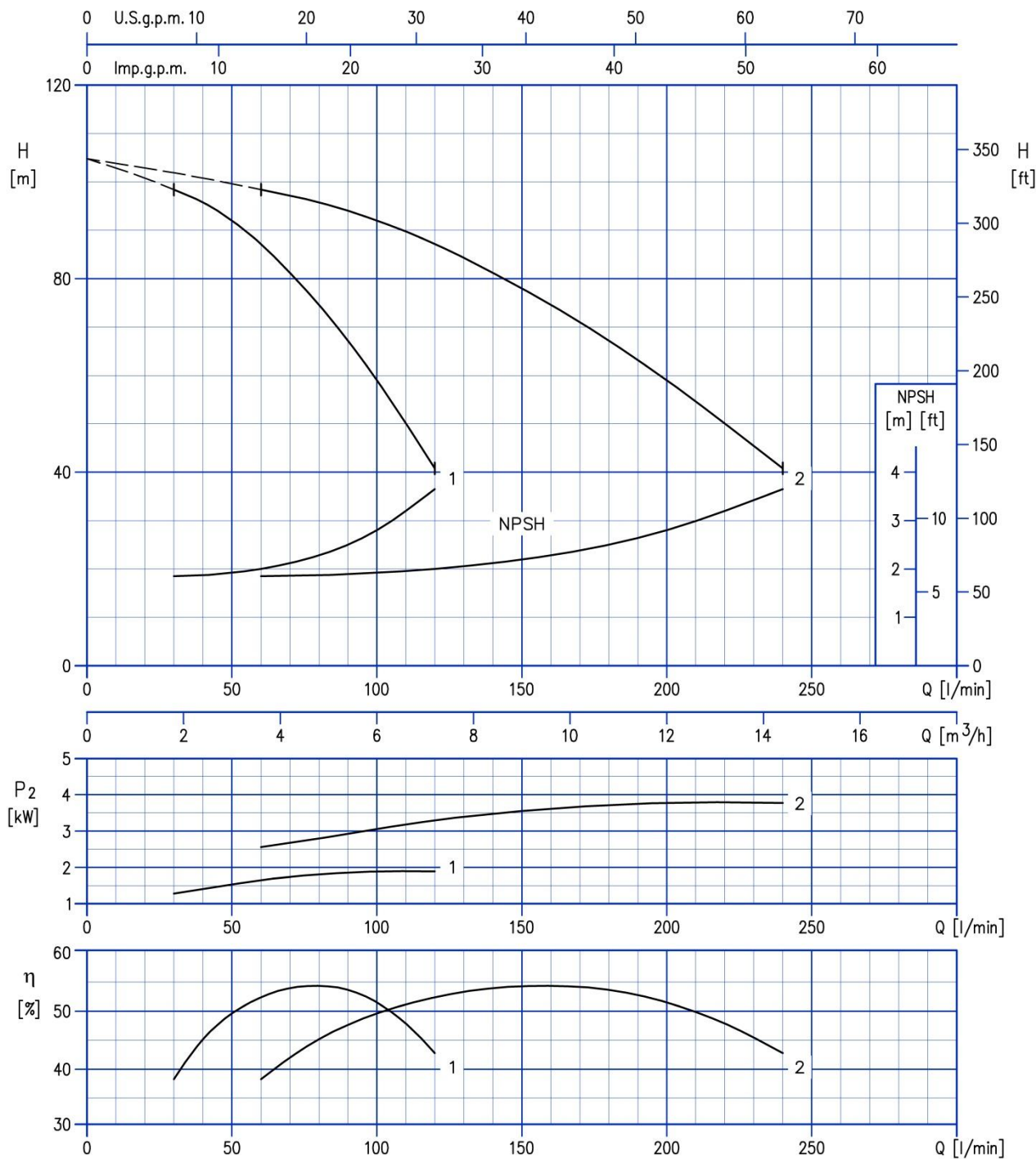

Test standard: ISO 9906: 2012 - Grade 3B

2GP CONSTRUCTION EXTERNAL VIEW 2GP CVM

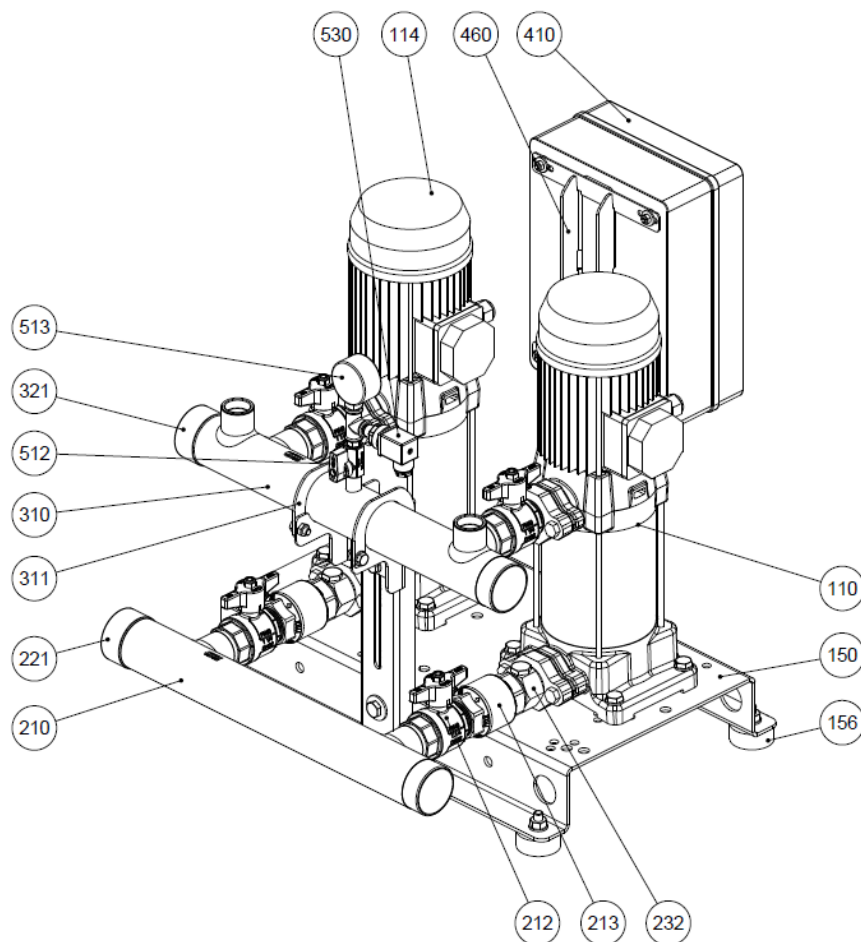

N°	PART NAME	MATERIAL	Quantity
110	Principal pump	-	2
114	Electric motor	-	2
150	Baseplate	Galvanized steel	1
156	Baseplate foot	SBR	4
210	Suction manifold	AISI 304	1
212	Ball valve	Brass / P.T.F.E.	2
213	Check valve	Brass / NBR	2
221	Threaded female cap	AISI 304	1
232	Nipple for air feeders	Yellow brass	2
310	Discharge manifold	AISI 304	1
311	Manifold bracket	Galvanized steel	2
312	Ball valve	Brass / P.T.F.E.	2
321	Threaded female cap	AISI 304	1
410	Control panel	-	1
460	Control panel frame	Galvanized steel	1
512	Ball valve	Brass / P.T.F.E.	1
513	Pressure gauge	Copper alloy / plastic	1
520	Pressure transmitter	-	1

601

2GPE CONSTRUCTION EXTERNAL VIEW 2GPE CVM E-SPD+

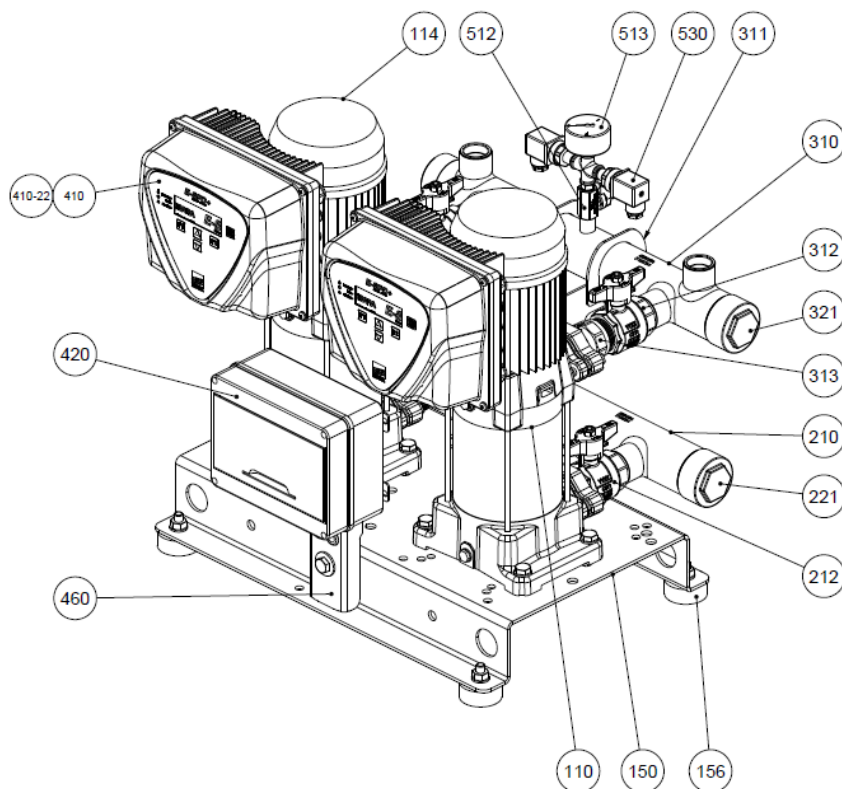

N°	PART NAME	MATERIAL	Quantity
110	Principal pump	-	2
114	Electric motor	-	2
150	Baseplate	Galvanized steel	1
156	Baseplate foot	SBR	4
210	Suction manifold	AISI 304	1
212	Ball valve	Brass / P.T.F.E.	2
221	Threaded female cap	AISI 304	1
310	Discharge manifold	AISI 304	1
311	Manifold bracket	Galvanized steel	2
312	Ball valve	Brass / P.T.F.E.	2
313	Check valve	Brass / NBR	2
321	Threaded female cap	AISI 304	1
410	E-SPD+	-	2
410-22	E-SPD+ adaptor	-	2
420	Protection panel	-	1
460	Protection panel frame	Galvanized steel	1
512	Ball valve	Brass / P.T.F.E.	1
513	Pressure gauge	Copper alloy / plastic	1
530	Pressure transmitter	-	2

OVERALL DIMENSIONS 2GP BOOSTER SET

2GP CVM

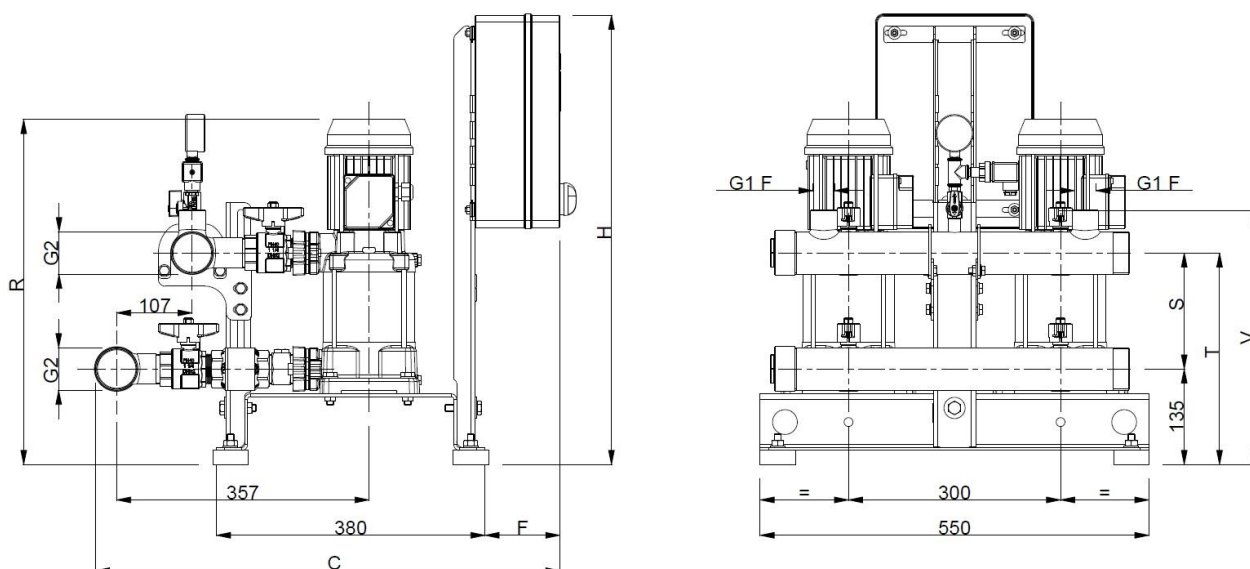

DIMENSIONS AND WEIGHT

Booster Type	Dimensions [mm]										Weight [kg]		
	1~ C	3~	1~ F	3~	1~ H	3~	1~ R	3~	S	T	V	1~	3~
2GP CVM A/8(M)	645	675	75	105	630	635	490	490	165	300	360	62	61
2GP CVM A/10(M)	645	675	75	105	630	635	550	550	190	325	385	69	69
2GP CVM A/12(M)	645	675	75	105	630	635	580	590	215	350	410	71	73
2GP CVM A/15(M)	645	675	75	105	630	635	615	615	240	375	435	73	73
2GP CVM A/18(M)	645	675	75	105	630	635	665	665	270	405	465	79	82
2GP CVM B/10(M)	645	675	75	105	630	635	500	500	140	275	335	68	68
2GP CVM B/12(M)	645	675	75	105	630	635	525	540	165	300	360	70	71
2GP CVM B/15(M)	645	675	75	105	630	635	565	565	190	325	385	72	72
2GP CVM B/20(M)	645	675	75	105	630	635	615	625	215	350	410	79	84
2GP CVM B/23(M)	645	675	75	105	630	915	650	650	240	375	435	81	85
2GP CVM B/25	-	675	-	105	-	915	-	680	270	405	465	-	85

Approximate dimensions ± 20 mm.
The dimensions may change without notice

OVERALL DIMENSIONS 2GPE BOOSTER SET 2GPE CVM E-SPD+

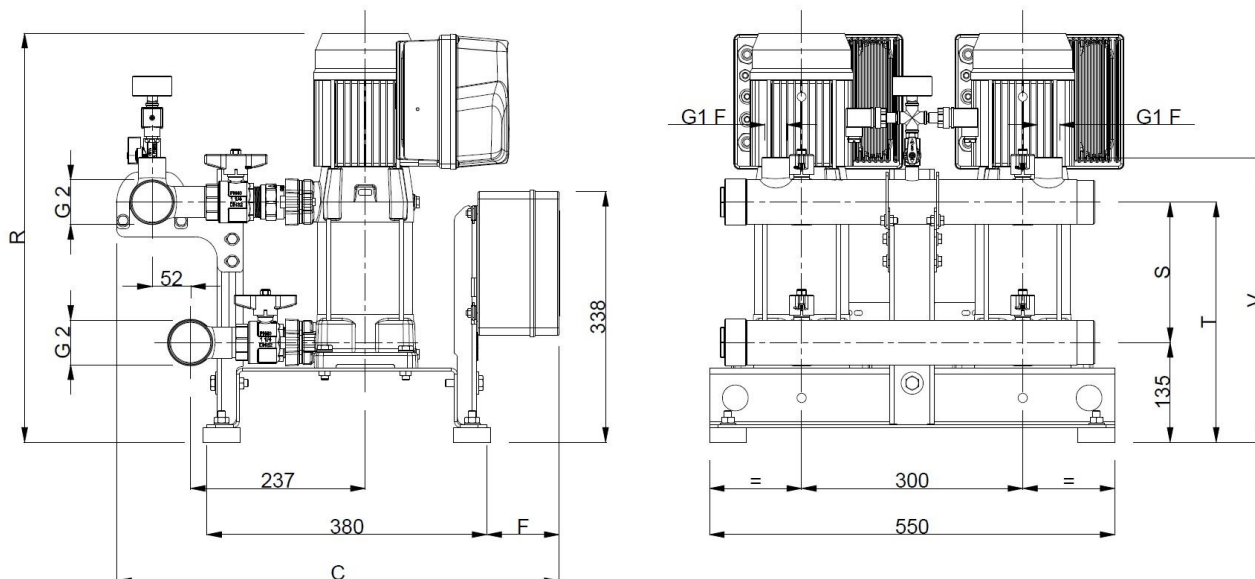

Booster Type	Dimensions [mm]								Weight [kg]	
	ESPM	ESPT	ESPM	ESPT	R	S	T	V	ESPM	ESPT
	C		F							
2GPE CVM A/10 ESPT(ESPM)	575	590	80	95	555	190	325	385	61	61
2GPE CVM A/12 ESPT(ESPM)	575	590	80	95	590	215	350	410	65	65
2GPE CVM A/15 ESPT(ESPM)	575	590	80	95	620	240	375	435	65	65
2GPE CVM B/12 ESPM	575	-	80	-	540	165	300	360	63	-
2GPE CVM B/15 ESPT(ESPM)	575	590	80	95	565	190	325	385	64	64
2GPE CVM B/20 ESPT(ESPM)	575	590	80	95	625	215	350	410	75	75
2GPE CVM B/23 ESPT	-	590	-	95	650	240	375	435	-	77

Approximate dimensions ± 20 mm.
The dimensions may change without notice

PACKING

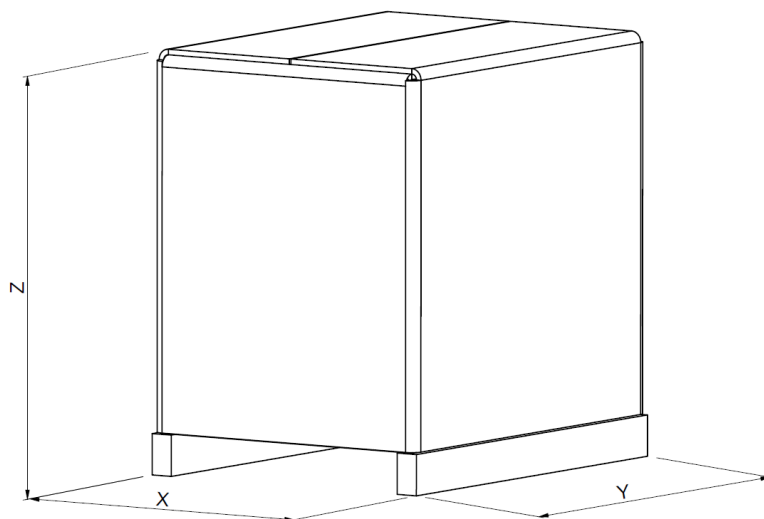

2GP(E) CVM

	Booster type	Overall dimensions packing			Booster+packing Weight [kg]
		X	Y	Z	
2GP	2GP CVM A/8M	660	870	780	87
	2GP CVM A/8	660	870	920	87
	2GP CVM A/10M	660	870	780	94
	2GP CVM A/10	660	870	920	94
	2GP CVM A/12(M)	660	870	920	98
	2GP CVM A/15M	660	750	1190	98
	2GP CVM A/15	660	870	780	98
	2GP CVM A/18(M)	660	870	780	107
	2GP CVM B/10(M)	660	870	780	93
	2GP CVM B/12(M)	660	870	780	96
	2GP CVM B/15(M)	660	870	920	97
	2GP CVM B/20M	660	870	780	109
	2GP CVM B/20	660	870	920	109
	2GP CVM B/23M	660	870	780	110
	2GP CVM B/23	660	870	920	110
	2GP CVM B/25	660	750	1190	110
2GPE E-SPD+	2GPE CVM A/10 ESPT(ESPM)	660	870	780	86
	2GPE CVM A/12 ESPT(ESPM)	660	870	780	90
	2GPE CVM A/15 ESPT(ESPM)	660	870	780	90
	2GPE CVM B/12 ESPM	660	870	780	88
	2GPE CVM B/15 ESPT(ESPM)	660	870	780	89
	2GPE CVM B/20 ESPT(ESPM)	660	870	920	100
	2GPE CVM B/23 ESPT	660	870	920	102

The dimensions may change without notice.

CONTROL PANEL FIXED SPEED

2EP-E SPECIFICATION

- **SERIES 2EP-E M UA (single-phase power output)**
- **SERIES 2EP-E T UA (three-phase power output)**

Electrical panel (protection and control) for two electropumps. Manual or automatic operation through pressure transmitter. The panel is configured to start the two pumps alternately in stand-by to pressure transmitter. The electrical panel protects the motors against overload and phase failure. Any protection devices that intervene are signalled on the panel itself and remotely through no voltage contacts. The protection device against overload and phase failure resets automatically three times, and manually after the fourth intervention.

TECHNICAL FEATURES

- P.MIN= Operation against dry running (tripped by a level float or minimum pressure switch) with automatic reset once water supply is restored, with warning lamp.
- TRP= control by pressure transmitter
- PR1= Pump n. 1 start/stop (not included in the pressure set)
- PR2= Pump n. 2 start/stop (not included in the pressure set)
- Automatic start sequence alternation
- Motor protection against overload with automatic reset for three times and manual reset the fourth time
- Motor line protection against short-circuits with fuses for motor startup
- Transformer and auxiliary circuit protection with fuses
- Remote signalling, through NC-NO no voltage contact, of the protection devices that intervene

Version		2EP-E M UA	2EP-E T UA
Power source	Frequency	50/60 Hz	
	Phase	Single-phase	Three-phase
	Voltage	230 V ± 10%	400 V ± 10%
	Power	0.55 ÷ 2.2 kW	1.1 ÷ 7.5 kW
Others	Protection degree	IP 56	
	Ambient Temperature	-10°C + 50°C up to 7.5 kW	
	Pressurisation units	2 pumps	
	Relative humidity	50% a 40°C MAX (90% a 20°C)	
	Max altitude	1000 m (a.s.l.)	
Directives	2014/35/EU (LVD), 2014/30/EU (EMC), 2011/65/EU (RoHS II)		

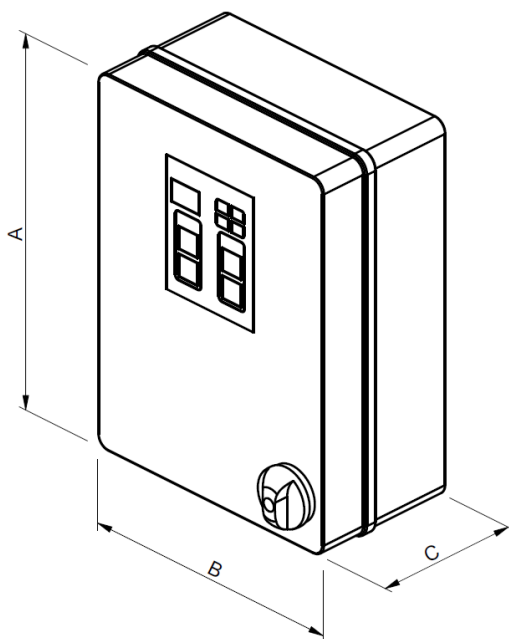

2EP-E M UA MODELS TABLE

Model	Single pump Power [kW]	I Calibration [A]	Motor fuse	Dimensions AxBxC [mm]	Weight [kg]
2EP-E 0,55 M	0,55	2x4,5	6A aM (10x38)	240 x 190 x 90	1,5
2EP-E 1,1 M	1,1	2x9	10A aM (10x38)	240 x 190 x 90	1,5
2EP-E 1,5 M	1,5	2x12	12A aM (10x38)	240 x 190 x 90	1,5
2EP-E 2,2 M	2,2	2x15	20A aM (10x38)	300 x 220 x 120	2,2

The dimensions may change without notice.

2EP-E T UA MODELS TABLE

Model	Single pump Power [kW]	I Calibration [A]	Motor fuse	Dimensions AxBxC [mm]	Weight [kg]
2EP-E 1,1 T	1,1	2x3.5	4A am (10x38)	300 x 220 x 120	3,5
2EP-E 2,2 T	2,2	2x5	8A am (10x38)	300 x 220 x 120	3,5

The dimensions may change without notice.

CONTROL PANEL VARIABLE SPEED E-SPD+ SPECIFICATION

On board electronic device for controlling electropumps, employing inverter technology. Starts and stops the pump and modulates the speed of the motor in relation to the water demand on the system, to maintain the operating pressure setting. Provides excellent comfort for the end user, significant energy savings and increased service life, the typical advantages of inverter controlled autoclave systems. E-SPD+ is an inverter that could be installed on the terminal box. It can be adapted on horizontal and vertical pumps. E-SPD+ can protect the system against overpressure, overcurrent, voltage fluctuation, dry run and water leak. The connection for this mode is made by communication line ON/OFF.

E-SPD+				
	Version	MT	TT	
Power	Power Voltage	Single-phase 230 V	Three-phase 400 V	
	Output Voltage (pump)	Three-phase 230 V	Three-phase 400 V	
	Output frequency	50 ÷ 60Hz		
	Maximum pump power	2.2 kW	4 kW	
	Max I in	20 A	12 A	
	Max I out	11 A	11 A	
	Others	Pressure setpoint	0.5 ÷ 40 bar	
Protection degree		IP 55		
Ambient Temperature		-10 ÷ 40°C		
Pressurisation units		2-3 pumps		
Weight		2,7 Kg		
Protection		Dry-running		
		Over/under voltage		
		Short-circuit		
		Overload		
		Overtemperature		
	Pressure sensor fault			
Directives	2014/35/EU (LVD), 2014/30/EU (EMC), 2011/65/EU (RoHS II)			

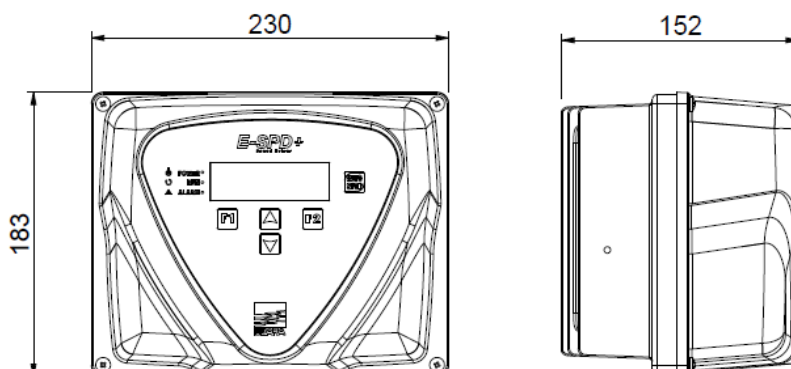

The dimensions may change without notice.

SP (EFC and MFC) SPECIFICATION

The control panels SP EFC/MFC series inverters modulate the operation of electropumps in response to control by the pressure transmitter (transducer measuring flow or other external signal 4-20 mA), regulating the speed of the electropumps to keep system demand constant. If the electronic controller or pressure transmitter fails, a system of pressure switches controls the pumps directly (if present).

VERSION

- “EFC”: Control panel for two or more electric pumps, with a single inverter with pump exchange
- “MFC”: Control panel for two or more electric pumps, with an inverter for each individual electropump

EFC / MFC		
Power	Power Voltage	Three-phase 400 V
	N° phases	Three phase without the use of neutral
	Frecuence	50/60Hz
	Pump power	From 1.5kW up to 30kW
	Protection degree	IP55 up to 2.2kW IP44 3kW and above
	Ambient Temperature	-10°C + 40°C
	Pressurisation units	2 or 3 pumps
Directives	2014/35/EU (LVD), 2014/30/EU (EMC), 2011/65/EU (RoHS)	

Single inverter with exchange pump (SP EFC)

Panel type	Pump motor power (Three-phase)	Starting (Emergency / fixed speed pumps)	Option
2/3 pumps	1.5÷7.5 kW	Direct	Inverter pump Exchange
	11÷30kW	Star-Delta	

Multi-inverter: one inverter for each pump (SP MFC)

Panel type	Pump motor power (Three-phase)	Starting (Emergency / fixed speed pumps)
2/3 pumps	1.5 - 7,5 kW	Inverter ramp
	11 - 30 KW	Inverter ramp

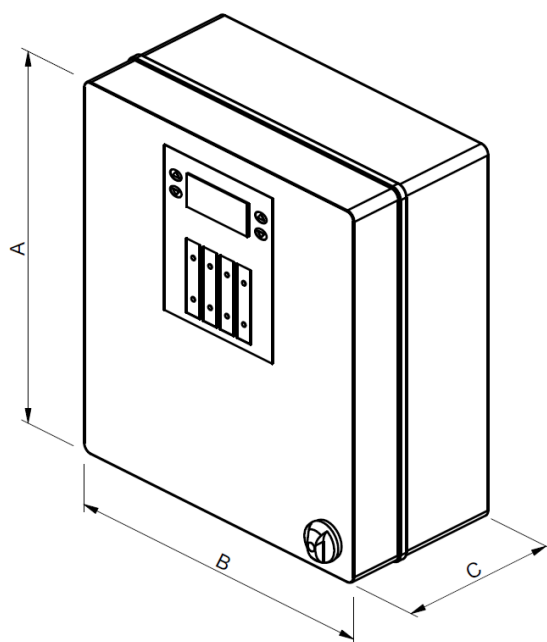

2SP EFC MODELS TABLE

Model	Motor power [kW]	Current [A]	Dimensions A-B-C [mm]	Weight [Kg]
2SP EFC 1,5T-2	2x1.5	2x3,7	450x400x200	25
2SP EFC 2,2T-2	2x2.2	2x5,3	450x400x200	25

The dimensions may change without notice.

3SP EFC MODELS TABLE

Model	Motor power [kW]	Current [A]	Dimensions A-B-C [mm]	Weight [Kg]
3SP EFC 1,5T-2	3x1.5	3x3,7	450x400x200	30
3SP EFC 2,2T-2	3x2.2	3x5,3	450x400x200	30

The dimensions may change without notice.

Notes: 4 pumps version are available with EP control panel on request

2SP MFC MODELS TABLE

Model	Motor power [kW]	Current [A]	Dimensions A-B-C [mm]	Weight [Kg]
2SP EFC 1,5T-2	2x1.5	2x3.7	500x400x200	28
2SP EFC 2,2T-2	2x2.2	2x5.3	500x400x200	28

The dimensions may change without notice.

3SP MFC MODELS TABLE

Model	Motor power [kW]	Current [A]	Dimensions A-B-C [mm]	Weight [Kg]
3SP MFC 1,5T-2	3x1.5	3x3.7	800x600x250	33
3SP MFC 2,2T-2	3x2.2	3x5.3	800x600x250	33

The dimensions may change without notice.

Notes: 4 pumps version are available with EP control panel on request

PROTECTION PANEL SPECIFICATION

Connection box for inverter :

- Connects the inverters with the power supply point.
- Equipped with circuit breakers on individual lines

Power source	Frequency	50/60 Hz	
	Phase	Single-phase	Three-phase
	Voltage	230 V ± 10%	400 V ± 10%
	Power	0.37 ÷ 3 kW	0.37 ÷ 15 kW
Others	Protection degree	IP 55	
	Ambient Temperature	-5°C + 40°C	
	Pressurisation units	2 pumps	
	Relative humidity	50% a 40°C MAX (90% a 20°C)	
	Max altitude	1000 m (a.s.l.)	
Directives	2014/35/EU (LVD), 2014/30/EU (EMC), 2011/65/EU (RoHS II)		

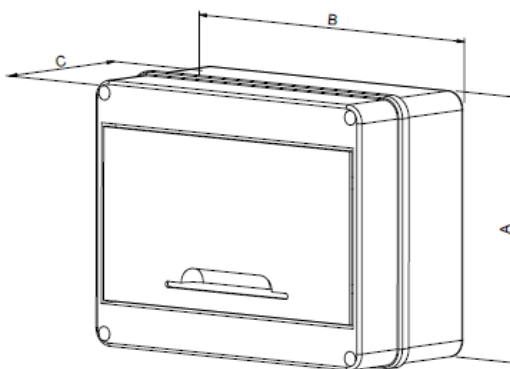

Model	N° Pumps	Power [kW]	Dimensions A-B-C [mm]	Max Current [A]
PROT.IP65 2P. 3M 20A NJ	2	2x3	160x200x90	2x20
PROT.IP65 2P. 4T 16A J		2x4	200x250x110	2x16
PROT.IP65 3P. 3M 20A NJ	3	3x3	160x200x90	3x20
PROT.IP65 3P. 4T 16A J		3x4	250x250x140	3x16

The dimensions may change without notice.



EBARA Pumps Europe S.p.A.

Via Torri di Confine 2/1 int. C
36053 Gambellara (Vicenza),
Italia Tel.: +39 0444 706811
Fax: +39 0444 405811
ebarapumps.epe@ebaracom
www.ebaraeurope.com

EBARA Corporation

11-1, Haneda Asahi-cho, Ota-ku,
Tokyo 144-8510
Japan
Tel. +81 3 6275 7598
Fax +81 3 5736 3193
www.ebara.com

