

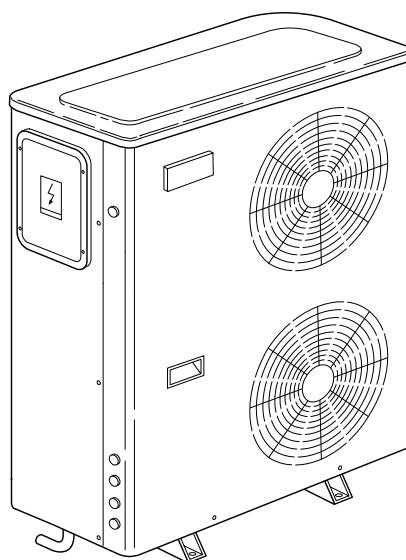

BY JOHNSON CONTROLS

Air-condensed cooling units and heat pumps YLCA / YLHA PLUS 5 to 27



Installation manual

Ref.: N-40314_EN 0910



Index

1	Installation manual.....	1
1.1	Safety instructions.....	2
1.2	Icons used in this document.....	2
1.3	Instructions for storage, transport, loading and unloading of the unit.....	3
1.3.1	Inspection.....	3
1.3.2	Disposal of packaging.....	3
1.3.3	Disposal of the unit.....	4
1.3.4	Handling.....	4
1.4	Selection guide (YLCA/YLHA).....	4
1.4.1	Selection guide with glycol (cool only units).....	7
1.5	Technical data.....	9
1.5.1	Limits of use.....	9
1.5.2	Correcting Factors.....	9
1.5.3	Physical data.....	15
1.5.4	Electrical specifications.....	17
1.6	Measurements, clearances and accesses.....	18
1.6.1	Clearances.....	18
1.6.2	Dimensions and hydraulic connections ⁿ (models YLCA/YLHA PLUS 5).....	20
1.6.3	Dimensions and hydraulic connections ⁿ (models YLCA/YLHA PLUS 7 and 9).....	21
1.6.4	Dimensions and hydraulic connections ⁿ (models YLCA/YLHA PLUS 12 and 15).....	22
1.6.5	Dimensions and hydraulic connections ⁿ (models YLCA/YLHA PLUS 20 and 27).....	23
1.7	Cooling capacities YLHA.....	24
1.7.1	Cooling capacities YLHA 5 ÷ 27.....	24
1.7.2	Cooling capacities YLHA 5 ÷ 27 (35% ethylene glycol).....	26
1.7.3	Heating capacities YLHA 5 ÷ 27.....	27
1.8	Cooling capacity YLCA.....	28
1.8.1	Cooling capacities YLCA 5 ÷ 27.....	28
1.8.2	Cooling capacities YLCA 5 ÷ 27 (35% ethylene glycol).....	29
1.9	Instructions for installation and connection of the unit.....	30
1.9.1	Characteristics of the location.....	30
1.9.2	Specifications for anchoring the unit.....	31
1.9.3	Hydraulic connections.....	32
1.9.4	Wiring diagrams.....	32
1.10	Instructions for starting up the unit.....	33
1.10.1	Rotational direction of Scroll compressors.....	33
1.11	Unit sound pressure data.....	33
1.12	Unit installation data.....	34
1.12.1	List of tests for unit start-up.....	34
1.12.2	Start-up Data.....	35
2	Electric circuit diagrams.....	37
2.1	Electric circuit diagram YLCA/YLHA PLUS 5+9 MC and M (230.1.50).....	38

2.2	Electric circuit diagram YLCA/YLHA PLUS 12 MC and M (230.1.50).....	40
2.3	Electric circuit diagram YLCA/YLHA PLUS 7 and 9 TC and T (400.3.50).....	42
2.4	Electric circuit diagram YLCA/YLHA PLUS 12 and 15 TC and T (400.3.50).....	44
2.5	Electric circuit diagram YLCA/YLHA PLUS 20 TC and T (400.3.50).....	46
2.6	Electric circuit diagram YLCA 27 TC, YLHA PLUS 27 (400.3.50).....	48
2.7	Electric circuit diagram YLCA PLUS 5 + 9 MCS (230.1.50) SOFT START.....	50
2.8	Electric circuit diagram YLCA PLUS 12 MCS (230.1.50) SOFT START.....	52

1

Installation manual

1.1 Safety instructions

This document contains the necessary information for the safe and efficient transportation, assembly and installation of the air conditioning unit. This guarantees the condition of the unit and its operating safety.

Only an authorised company may assemble the air conditioning unit.



ATTENTION

Only authorised companies with the appropriate technical resources and suitably trained personnel may install the air conditioning unit.



CAUTION

The specialists responsible for installing the air conditioning unit must make sure they have all of the information and knowledge required to correctly install, test and deliver the unit. Johnson Controls Inc. shall not be considered responsible for any damage caused by installation of the unit that is not consistent with that described in this document or others specifically provided with the unit.

During regular equipment installation, the fitter must pay special attention to certain situations in order to prevent injuries or damage to the unit.

Situations that could jeopardise the safety of the fitter or that of others nearby or that could put the unit itself at risk are clearly indicated in this manual.

A series of special symbols are used to clearly identify these situations.

Pay careful attention to these symbols and to the messages following them, as your safety and the safety of others depends on it.

1.2 Icons used in this document



DANGER

- *The text following this symbol contains information and instructions relating directly to your safety and physical wellbeing.*
- *Not taking these instructions into account could lead to serious, very serious or even fatal injuries to you and others in the proximities of the unit.*

Information can also be found on safe procedures during unit handling. This will help reduce the risk of accidents.



CAUTION

- *The text following this symbol contains information and instructions relating directly to your safety and physical wellbeing.*
- *Not taking these instructions into account could lead to minor injuries to you and others in the proximities of the unit.*
- *Not taking these instructions into account could lead to unit damage.*

Information can also be found on safe procedures during unit handling. This will help reduce the risk of accidents.



NOTE

- *The text following this symbol contains information or instructions that may be of use or that is worthy of a more thorough explanation.*
- *Instructions regarding inspections to be made on unit parts or systems may also be included.*

1.3 Instructions for storage, transport, loading and unloading of the unit



CAUTION

Outdoor units must be moved and stored vertically to prevent oil from leaking from the compressor.

Delivery inspection

The unit should be carefully inspected for visible damage or abnormalities as soon as it is received.

Any abnormalities or damage to the unit should be communicated to both the transportation and insurance company in writing.

Storage instructions

The unit should be stored in a place suitable to the purpose (warehouse or similar), protected from the weather, water, humidity and dust.

Cover the unit with a canvas of a suitable size.

The unit should be appropriately protected from knocks and dust, ensuring the protective parts it was supplied with remain in place. Where these are not in place, establish the necessary protections and/or barriers to keep vehicles or fork-lift trucks away.

Transport, loading and unloading of the unit

The units should only be handled by personnel from the company responsible for their installation.

Transport of the unit should be in such a manner that no damage is caused by faulty or inadequate mooring to the bed or body of the vehicle.

Where necessary, protect all of the edges of the unit against knocks and scratches and moor it to the bed or body of the vehicle using suitable textile belts or slings to keep it perfectly still.

Loading and unloading the unit from a truck or trailer should be on flat, solid ground using an appropriate crane with sufficient capacity.

1.3.1 Inspection

Upon reception, inspect the goods and notify the carrier and the insurance company, in writing, of any possible damage during transportation.

1.3.2 Disposal of packaging

The packaging is recyclable. Dispose of it in the appropriate place or take it to an appropriate collection centre. Respect the regulations in force for this type of waste in the country where the unit is being installed.

Packaging remains must be correctly disposed of. Improper disposal of packaging generates environmental problems that affect human life.

1.3.3 Disposal of the unit

When removing the unit, the components must be ecologically recovered. The cooling circuit is full of coolant that must be extracted and delivered to the gas manufacturer for recycling.



ATTENTION

The refrigerant gas contains greenhouse-effect fluorinated gas covered by the Kyoto protocol.

Please see the specifications plate for type of gas and quantity per system.

GWP (Global Warning Potential): 2088

There will be oil left in the hermetic compressor, therefore it must be delivered with the circuit sealed.

The air conditioner shall be deposited in the area established by local authorities, to facilitate its selective recovery.

1.3.4 Handling

The unit must be moved using the metal rails provided for its installation and transport

1.4 Selection guide (YLCA/YLHA)

Necessary information

The following information is needed to select a YLCA/YLHA water cooling unit:

- 1 Cooling capacity needed
- 2 Design cold water inlet and outlet temperatures.
- 3 Design water flow rate, if one of the temperatures of Point 2 above is unknown.
- 4 Design inlet temperature of air to the condenser. Normally, this will be the design ambient temperature of summer air, unless influenced by the situation or other factors.
- 5 Altitude above sea level.
- 6 Design fouling factor of the evaporator.



NOTE

Points 1, 2 and 3 should be related by means of the following formulae:

$$\text{Cooling capacity kW} = \frac{\text{l/h cold water} \times \text{differential } ^\circ\text{C}}{860}$$

SELECTION EXAMPLE

A cooler is required to chill water from 13°C to 7°C, with a cooling capacity of 5 kW.

There are also other design conditions:

- Inlet ambient air in the condenser 35 °C
- Fouling factor: 0,044 m² °C/kW
- Altitude: Sea level

From a quick glance at the table *Cooling capacities YLCA 5 ÷ 27, see on page 28* it can be seen that a YLCA 5 gives approximately the required capacity of 5,38 kW.

As the factors appearing in tables *Fouling factors, see on page 9* and *Altitude factors, see on page 12* are not applicable, the conditions will be as follows:

- Cooling capacity: 5,38 kW
- Power consumed: 1,87 kW
- Water temperature: 13°C to 7°C (Temp. difference of 6)

$$\text{Water flow rate} = \frac{5,38 \times 860}{6} = 771 \text{ l/h}$$

Available pressure in the unit's hydraulic circuit:

- From Table *Pressure available for the hydraulic circuit and pressure drop in the hydraulic circuit (without filter mounted), see on page 13* we infer that the YLCA 5 MC, with a flow rate of 771 l/h, has an available pressure of 56 kPa.

Pressure drop in filter:

- From Table *Pressure drop in filters, see on page 14* we infer that with a flow rate of 771 l/h, there is a pressure drop of 1,3 kPa.

YLHA PLUS selection method

- 1 Establish the correct size of YLHA PLUS by selecting the model from the tables *Heating capacities YLHA 5 ÷ 27, see on page 27* and *Cooling capacities YLCA 5 ÷ 27, see on page 28* that is closest to the cooling and heating capacities required in design conditions of the water outlet temperature and air inlet temperature.
- 2 Apply fouling correction factors (table *Fouling factors, see on page 9*) and height correction factors (table *Altitude factors, see on page 12*) to the capacity and power values shown in the corresponding tables of capacity for the cool and heat modes. Make sure the corrected capacity is still sufficient for your needs.
- 3 Using the corrected capacities of the unit, select the design temperature differential or the flow rate.
- 4 Check to make sure that these selections are within the YLCA/YLHA PLUS operating limits.

YLHA PLUS SELECTION EXAMPLE

A YLHA PLUS 5 heat pump operating at a 35 °C ambient temperature should cool water from 13 °C to 7 °C, with a 5 kW cooling capacity.

A 4 kW heating capacity is required in 0 °C design ambient temperature and a hot water outlet temperature of 45 °C.

The fouling factor is 0,044 m² °C/kW, with the unit operating at sea level (no corrections). From a quick glance at the tables *Heating capacities YLHA 5 ÷ 27, see on page 27* and *Cooling capacities YLCA 5 ÷ 27, see on page 28* we see that a YLHA PLUS 5 heat pump approximately gives the required capacities:

- Cooling capacity = 5,4 kW
- Total unit absorbed power = 1,91 kW
- Cold water temperature = 13 °C to 7 °C (Temp. diff. of 6 °C)
- Hot and cold water flow rate = 774 l/h
- Heating capacity = 4,15 kW
- Total unit absorbed power in heat mode = 1,88 kW
- Hot water outlet temperature = 45 °C

$$\text{Hot water temp. dif-ferential} = \frac{4,15 \times 860}{774} = 4,60 \text{ °C}$$

Thus, hot water return temperature is = 40,4 °C

All values are within operating limits:

- Available pressure in hydraulic circuit of a unit with pack:
- From Table *Pressure available for the hydraulic circuit and pressure drop in the hydraulic circuit (with-out filter mounted), see on page 13* we infer that the YLHA PLUS 5 MC, with a flow rate of 748 l/h, has an available pressure of 56,5 kPa.
- Pressure drop in filter.
 - From Table *Pressure drop in filters, see on page 14*, 1" filter, we infer that with a 748 l/h flow rate, said filter has a pressure drop of 1,2 kPa.

1.4.1 Selection guide with glycol (cool only units)

Necessary information

The following information is needed to select a YLCA cooling unit:

- 1 Cooling capacity needed
- 2 Design cold water/glycol inlet and outlet temperatures.
- 3 Design water/glycol flow rate.
- 4 Design inlet temperature of air to the condenser. Normally, this will be the design ambient temperature of summer air, unless influenced by the situation or other factors.
- 5 Altitude above sea level.
- 6 Design fouling factor of the evaporator.



NOTE

Points 1, 2 and 3 should be related by means of the following formulae:

$$\text{Capacity (kW)} = \frac{\text{Temp. diff. (°C)} \times \text{Flow rate (litres/sec.)}}{\text{Glycol factor}}$$

$$\text{Temp. differential (°C)} = \text{Liquid Inlet Temp.} - \text{Liquid Outlet Temp.}$$

To determine the glycol factor, please see [Glycol concentration and correcting tables, see on page 10](#) (Recommended ethylene glycol concentrations) for ethylene glycol or (Recommended propylene glycol concentrations) for propylene glycol. For design outlet temperature, please see the recommended glycol concentration and the glycol factor in this concentration. This is the minimum concentration to be used for design outlet temperature. If a greater concentration is required, the glycol factor can be determined by means of [Glycol concentration and correcting tables, see on page 10](#) (Ethylene glycol in other concentrations) or (Propylene glycol in other concentrations).

Selection method

- 1 Determine the correct cooling unit model by selecting the one that is closest to the capacities required by the design conditions of the glycol outlet and air inlet temperatures.
- 2 Apply the fouling correcting factors that correspond to the fouling, altitude and glycol concentration factor, to the capacity and power values in the capacity tables. Make sure the corrected capacity is still sufficient for your needs.
- 3 Using the corrected capacities of the cooler, set the design temperature range, or the flow rate, to balance the formulae appearing in [Selection guide \(YLCA/YLHA\), see on page 4](#).
- 4 Always recheck to make sure these selections are within the specified design limits.

Selection example

A cooler is required to chill ethylene glycol from 1 a to -4 °C, with an output of 3,5 kW.

The following design conditions are applicable:

- Fouling factor: 0,088m °C/kW
- Altitude: 1 200m
- Ambient air: 30 °C
- Glycol concentration: 30% w/w

For a -4 °C ethylene glycol outlet, the concentration recommended in Figure 1 is 30%. Therefore, the specified concentration is appropriate.

From Table [Cooling capacities YLCA 5 ÷ 27 \(35% ethylene glycol\), see on page 29](#), we infer that a YLCA 5 unit, at the established design conditions, gives a capacity of 3,4 kW and a consumption of 1,35 kW.

With the design fouling factor, use the capacity correcting factors x 0,987 and power x 0,995 (see [Fouling factors, see on page 9](#)).

On design altitude, apply the capacity correcting factors x 10,973 and power x 1,020 (see [Altitude factors, see on page 12](#)).

On design glycol concentration, apply the capacity correcting factors x 1,015 and power x 1,005 (see [Correcting factors for other glycol concentrations](#), see on page 12).

Applying these factors to the selection: YLCA 5

$$\text{Capacity} = 3,44 \times 0,987 \times 0,973 \times 1,015 = 3,35 \text{ kW}$$

$$\text{Comp. power} = 1,35 \times 0,995 \times 1,020 \times 1,005 = 1,37 \text{ kW}$$

For the specified glycol concentration and a -4 °C outlet temperature, Figure 3 shows a 0,248 glycol factor. Thus, the flow rate can be determined with the formula appearing in [Selection guide \(YLCA/YLHA\)](#), see on page 4.

$$3,35 \text{ [kW]} = \frac{(1 - (-4)) \times \text{Flow rate [l / s]}}{0,248}$$

$$\text{Flow rate} = \frac{3,35 \times 0,248}{5} = 0,166 \text{ [l / s]} \text{ or } 598 \text{ [l / h]}$$

This covers the Limits of Use.

The evaporator pressure drop can be determined by taking the water pressure drop value for a YLCA unit and multiplying it by the correction factor (see [Glycol concentration and correcting tables](#), see on page 10) for a 30% concentration and an average temperature of -1,5 °C, i.e.:

$$-1,5 \text{ °C} = \frac{1 + (-4)}{2}$$

$$42 \text{ kPa} \times 1,22 = 51,2 \text{ kPa.}$$

1.5 Technical data

1.5.1 Limits of use

Model	Voltage limits		Inlet air temperature to the coil DB				Water outlet temperature				Temperature difference between water outlet and inlet	
	Nominal at 400		Operating cycle				Operating cycle				Minimum °C Maximum °C	
			Minimum °C		Maximum °C		Minimum °C		Maximum °C			
	Mini- mum	Maxi- mum	Cold	Hea t	Cold	Hea t	Cold	Heat	Cold	Heat	Minimum °C	Maximum °C
YLCA				-		-		-		-		
YLHA PLUS	342	436	-10(2)	-10	46	20	5(1)	30	15	50(3)		

- (1) At lower water temperatures, it is advisable to use glycol-type antifreeze mixtures. Minimum temp. with glycol -5 °C.
- (2) -18 °C with low temperature (optional) in models YLCA/YLHA PLUS 20, 27.
- (3) 50 °C if the inlet air temp. is higher than 0 °C.

Prior to final approval of the installation

Check:

- Voltage remains between 342 - 436 V.A.



CAUTION

The cable used for the unit power supply must be H05 RN - F

- Power supply cable cross-section is at least as indicated in the corresponding wiring diagrams. The cable used for the unit power supply must be H05 RN-F.
- Operating instructions have been given to the user.
- The warranty card has been filled out.
- Maintenance instructions have been given, or a regular maintenance contract has been signed.

1.5.2 Correcting Factors

Fouling factors

Evaporator		
Fouling Factor m ² °C/kW	Capacity factor	compressor absorbed power factor
0,044	1	1
0,088	0,987	0,995
0,176	0,964	0,985
0,352	0,926	0,962

Glycol concentration and correcting tables

Recommended ethylene glycol concentrations

A	% in weight	a	Recommended concentration % in weight
B	Outlet liquid temperature °C	b	Freeze point
C	Glycol factor L/S °C/ kW in recommended concentrations	c	Glycol factor in recommended concentrations

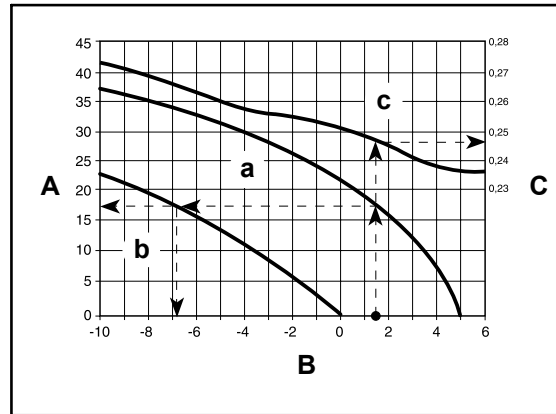

Ethylene glycol in other concentrations.

A	Glycol factor
B	Outlet liquid temperature °C
C	Glycol factor

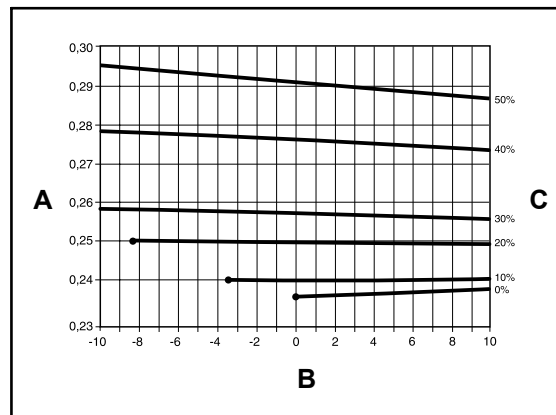

Recommended propylene glycol concentrations

A	% in weight	a	Recommended concentration % in weight
B	Outlet liquid temperature °C	b	Freeze point
C	Glycol factor L/S °C/ kW in recommended concentrations	c	Glycol factor in recommended concentrations

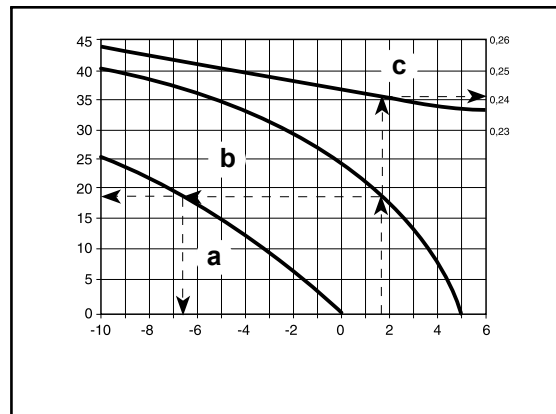

Propylene glycol in other concentrations

- A Glycol factor
- B Outlet liquid temperature °C
- C Glycol factor

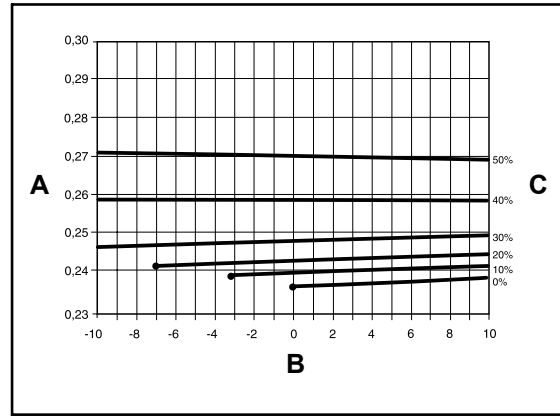

Ethylene glycol pressure drop correcting factor

- A Correcting Factor
- B Average liquid temperature °C
- C Glycol concentration P/P

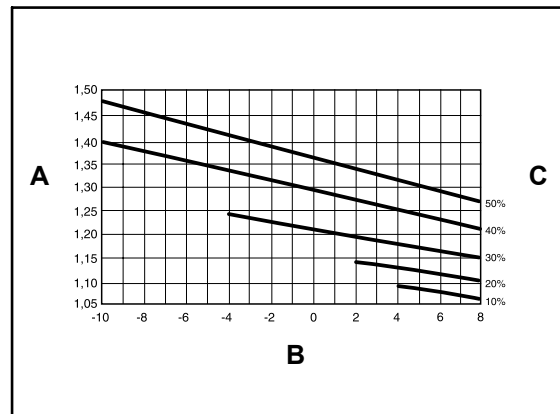

Propylene glycol pressure drop correcting factor

- A Correcting Factor
- B Average liquid temperature °C
- C Glycol concentration P/P

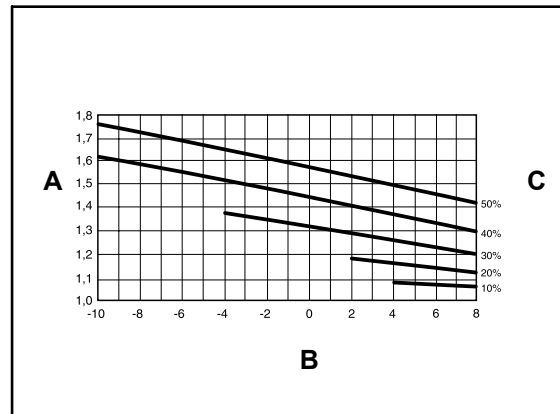

Correcting factors for other glycol concentrations

% in weight	Ethylene glycol		Propylene glycol	
	Capacity	Absorbed power	Capacity	Absorbed power
10	1,061	1,025	1,097	1,033
20	1,036	1,015	1,067	1,023
30	1,015	1,005	1,026	1,008
35	1	1	1	1
40	0,985	0,995	0,974	0,992
50	0,954	0,985	0,923	0,977

If it is necessary to select different glycol percentages, correct the capacity and absorbed power capacities of tables 2 and 4 (35% ethylene glycol), multiplying them by the coefficients indicated in the table.

Altitude factors

Altitude	Capacity factor	compressor absorbed power factor
0	1	1
600	0,987	1,01
1200	0,973	1,02
1800	0,958	1,029
2400	0,943	1,038

Pressure available for the hydraulic circuit and pressure drop in the hydraulic circuit (without filter mounted)

YLCA/YL-HA PLUS model	Flow rate l/h	Avail. kPa	YLCA/YLHA PLUS model	Flow rate l/h	Avail. kPa	
05	600	61	15	1 700	221	
	800	55		2 000	200	
	1 000	46		2 300	170	
	1 200	36		2 600	140	
	1 400	25		2 900	105	
07	800	96		3 200	60	
	1 000	91		3 500	10	
	1 200	81		20	2 000	175
	1 400	70			2 500	160
	1 600	58			3 000	145
	1 800	45	3 500		125	
	2 000	28	4 000		105	
09	1 000	95	4 500		83	
	1 200	88	5 000		60	
	1 400	80	5 500	30		
	1 600	70	27	3 000	245	
	1 800	60		3 500	228	
	2 000	49		4 000	208	
	2 200	37		4 500	187	
	2 400	24		5 000	163	
12	1 400	149		5 500	140	
	1 700	134		6 000	112	
	2 000	118		6 500	83	
	2 300	95	7 000	49		
	2 600	62	7 500	15		
	2 900	30				

Data with water at 10°C.

In the case of using glycol, apply the correcting factors indicated in Section [Correcting factors for other glycol concentrations](#), see on page 12.

Pressure drop in filters

1" filter

Water flow rate (l/h)	600	800	1000	1200	1400	1600
kPa	0,7	1,4	2,6	4,3	6,4	8,9
Water flow rate (l/h)	1800	2000	2200	2400	2600	
kPa	11,8	15,1	18,8	22,8	27,1	

1 1/4" filter

Water flow rate (l/h)	1500	2000	2500	3000	3500
kPa	0,9	1,5	2,6	3,9	5,6
Water flow rate (l/h)	4000	4500	5000	5500	6000
kPa	7,7	10,1	12,8	15,7	18,8

Data with water at 10°C.

In the case of using glycol, apply the correcting factors indicated in Section [Correcting factors for other glycol concentrations](#), see on page 12.

1.5.3 Physical data

Physical data, YLCA units

Physical data

Characteristics			YLCA (M and MC)			YLCA (T and TC)					
			5	7	9	7	9	12	15	20	27
Cooling capacity	kW	5,38	7,13	9,05	7,13	9,05	12,4	14,5	19,52	25,6	
Capacity control	%										
Power supply	V/ph	230.1.50			400.3.50						
Max. unit power supply consumption	kW	2,57	3,61	4,36	3,61	4,36	5,68	8	9,17	12,09	
Max. unit current amperage	A	11,75	17,1	23	7,6	8,25	11,6	15,8	18,1	23	
EER		2,87	2,76	2,79	2,76	2,81	2,97	2,52	2,81	2,81	
Compressor	Compressor power	kW	1,73	2,41	3,2	2,41	3,2	3,8	5,38	6,57	8,73
	Compressor amperage	A	7,8	11,7	16	3,9	5,3	6,36	8,9	13	16,7
	No. of compressors		1								
	Compressor type		SCROLL								
	Oil charge	l	1,1	1,25				1,95	1,66	2,51	3,25
	Oil type		POLYOL ESTER OIL								
	Compressor start-up current	A	60	82	97	35	48	51	74	95	118
Evaporator unit type		PLATES									
Fan	No. of fans		1				2				
	Fan diameter	mm	450								560
	Fan power	W	140	170				2 x 185		2 x 175	
	Fan amperage	A	0,6	0,8				2 x 0,87		2 x 0,85	
	Total air flow rate	m ³ /h	2900	3150				6150		6300	7200
	Sound power	dB(A)	70	70	71	70	71	73	73	74	78
	Sound pressure at 5 m	dB(A)	44	44	45	44	45	47	47	48	51
	Sound pressure at 10 m	dB(A)	40	40	41	40	41	43	43	44	48
	Available static pressure at nominal flow rate (without filter) (2)	kPa	51	80	78	80	75	115	152	134	191
	Available static pressure at nominal flow rate (with filter) (3)	kPa	49	75,5	71	75,5	67,5	113	149	129,5	182
Coolant	Coolant type		R-410A								
	Coolant charge	kg	2,08	2,55	2,25	2,55	2,15	3,17	3,1	5	7,8
	No. of coolant circuits										
Water circuit	Nominal water flow rate	l/h	925	1225	1430	1225	1475	2065	2530	3360	4405
	Min water volume inst. (1)	l	15	20	25	20	25	35	45	55	75
	Water connection, female		1"						1 1/4"		
	water filter, female		1"				1 1/4"				
	No. of pumps		1								
	Pump power	W	160	210				400	490	390	755
	Pump amperage	A	0,65	0,95				1,8	2,15	1,1	1,34
	Unit water content	l	1	1,1	1,2	1,1	1,2	1,5	2	2,8	3,2
	Volume of expansion vessel	l	1	2				5			8
Safety valve setting	MPa (bar)	0,6 (6)									
Dimensions and weight	Weight (4)(5)	kg	75	99	100	99	100	146	160	220	290
	Length	mm	905						1430		1876
	Width	mm	460						502		
	Height	mm	762	965				1270			

- (1) Minimum volume of water in installation: In installations with smaller volumes, and under low load conditions, the function "Omission of inertia tank" is automatically activated. As a result, the water temperature becomes less accurate as the total volume of water in the installation is reduced.
- (2) Please enquire before applying values lower than those shown.
- (3) Static pressure available, Eurovent certified. Pressure with clean filter.
- (4) Weights for the empty unit.

1.5 Technical data

Physical data, YLHA units

Physical data

Characteristics		YLHA PLUS MC				YLHA PLUS TC						
		5	7	9	12	9	12	15	20	27		
Cooling capacity	kW	5,4	7,10	8,72	11,75	8,72	12	13,8	19,4	25,8		
Heating capacity	kW	6,3	7,16	10,1	12,25	10,1	12,4	16,1	20,9	27,5		
Power supply	V/ph	230.1.50				400.3.50						
Max. unit power supply consumption	kW	2,57	3,48	4,79	5,51	4,79	5,68	7,6	8,70	12,09		
Max. unit current amperage	A	11,75	16,4	23	25,7	5,5	11,6	12,4	15,5	21		
EER/COP nominal conditions		2,82/3,32	2,75/2,90	2,73/3,25	2,75/3,12	2,73/3,25	2,88/3	2,52/3,12	2,75/3,25	2,90/3,30		
COP air 7/6 - water 30/35		3,78	3,48	3,88	4,01	3,88	3,86	4	3,96	4,03		
Compressor	Compressor power in cooling	kW	1,77	2,41	3,16	3,90	3,16	3,8	5,13	6,71	8,47	
	Compressor power in heating	kW	1,76	2,30	3,06	3,55	3,06	3,77	4,81	6,06	7,89	
	Compressor amperage in cooling	A	8,4	11,7	15,6	20,2	5,3	6,36	8,7	11,7	15,1	
	Compressor amperage in heating	A	8,1	11,2	14,4	18,7	5,1	6,38	8,2	10,8	14,3	
	No. of compressors		1									
	Compressor type		SCROLL									
	Oil charge	l	1,1	1,25	1,24	1,25	1,24	1,89	2,51	3,25		
	Oil type		POLYOL ESTER OIL									
Compressor start-up current (5)	A	60/<45	82/<45	97/<45	116/<52	48	51	74	95	118		
Evaporator unit type		PLATES										
Fan	No. of fans		1		2	1	2					
	Fan diameter	mm	450								560	
	Total fan power	W	140	170	2 x 185	170	2 x 185	2 x 180	2 x 200			
	Total fan current	A	0,6	0,8	2 x 0,87	0,8	2 x 0,87		2 x 1,30			
	Total air flow rate	m³/h	2900	3150			6150		6300	7200		
	Sound power	dB(A)	70	70	71	73	71	73	73	74	78	
	Sound pressure at 5 m	dB(A)	44	44	45	47	45	47	47	48	51	
	Sound pressure at 10 m	dB(A)	40	40	41	43	41	43	43	44	48	
	Available static pressure at nominal flow rate (without filter) (2)	kPa	51	80	75	116	75	118	160	130	191	
	Available static pressure at nominal flow rate (with filter) (3)	kPa	49	76	67,5	100	67,5	116	157,5	124	182	
	Coolant	Coolant type		R-410A								
		Coolant charge	kg	1,86	2,55	2,35	3,14	2,35	3,50	3,40	5,80	8,20
No. of coolant circuits												
Water circuit	Nominal water flow rate	l/h	930	1220	1430	2020	1495	1980	2375	3335	4440	
	Min water volume inst. (1)	l	15	20	25	35	25	35	45	55	75	
	Water connection, female		1"						1 1/4"			
	water filter, female		1"				1 1/4"					
	No. of pumps		1									
	Pump power	W	160	210	400	210	400	490	390	755		
	Pump amperage	A	0,65	0,95	1,8	0,95	1,8	2,15	1,1	1,34		
	Unit water content	l	1	1,1	1,2	1,5	1,2	1,5	2	2,8	3,2	
	Volume of expansion vessel	l	1	2	5	2	5			8		
Safety valve setting	MPa (bar)	0,6 (6)										
Dimensions and weight	Weight (4)(5)	kg	77	102	103	154	103	150	164	235	330	
	Length	mm	905						1430	1876		
	Width	mm	460						502			
	Height	mm	762	965	1270	965	1270					

- (1) Minimum volume of water in installation: In installations with smaller volumes, and under low load conditions, the function "Omission of inertia tank" is automatically activated. As a result, the water temperature becomes less accurate as the total volume of water in the installation is reduced.
- (2) Please enquire before applying values lower than those shown.
- (3) Static pressure available, Eurovent certified. Pressure with clean filter.
- (4) Weights for the empty unit.
- (5) With Soft Start.

1.5.4 Electrical specifications

Model	Power supply V.ph.Hz.	Compressor						Fans		Pump	
		Nominal A		Start-up A		Nominal kW		Nominal A	Nominal W	Nominal A	Nominal W
		Cold	Heat	Standard	Soft Start	Cold	Heat				
YLCA 5	230.1.50	7,80	-	60	<45	1,73	-	0,60	140	0,65	160
YLHA PLUS 5		7,80	8,10			1,73	1,76				
YLCA 7		11,70	-	82	<45	2,41	-	0,80	170	0,95	210
YLHA PLUS 7		12,40	13,20			2,56	2,76				
YLCA 9		17	-	97	<45	3,20	-	2 x 0,87	2 x 185	1,80	400
YLHA PLUS 9		17	14,50			3,16	3,06				
YLHA PLUS 12		16,30	14,80	116	<52	3,29	2,98				
YLCA 7	400.3.50	3,90	-	35	-	2,41	-	0,80	170	0,95	210
YLHA PLUS 7		4,10	4,80		-	2,56	2,76				
YLCA 9		5,70	-	48	-	3,20	-	2 x 0,87	2 x 185	1,80	400
YLHA PLUS 9		6	5,80		-	3,16	3,06				
YLCA 12		6,36	-	51	-	3,80	-	2 x 0,87	2 x 185	2,15	490
YLHA PLUS 12		6,36	6,38		-	3,80	3,77				
YLCA 15		8,90	-	74	-	5,38	-	2 x 0,8	2 x 170	1,10	390
YLHA PLUS 15		8,70	8,90		-	5,25	5,23				
YLCA 20		13	-	95	-	6,65	-	2 x 0,85	2 x 175	1,34	755
YLHA PLUS 20		12,20	11,70		-	6,62	6,26				
YLCA 27		16,70	-	118	-	8,73	-	2 x 0,85	2 x 175	1,34	755
YLHA PLUS 27	16,70	16	-		8,73	8,24					

1.6 Measurements, clearances and accesses

1.6.1 Clearances

When installing each unit, clearances should be left for:

- 1 Air inlet and discharge.
- 2 Maintenance servicing.
- 3 Power supply connections.

To operate correctly, all minimum clearances shown on the general dimension diagrams should be respected, with regard to the possible obstruction of air circulation or of the work of an operator.

Minimum technical clearance YLCA 5, 7, 9, 12 and 15

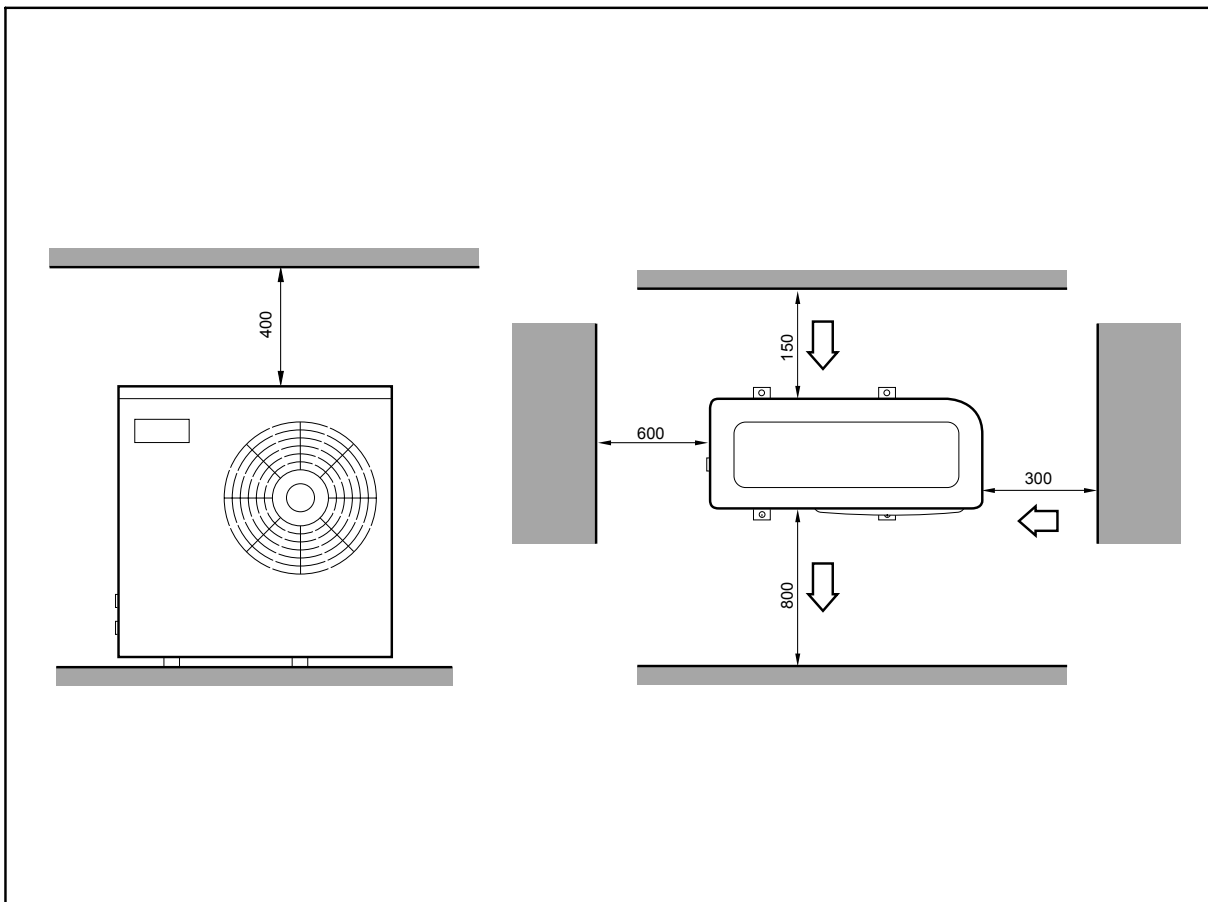

NOTE

Distances in millimetres

Minimum technical clearance YLCA/YLHA PLUS 20 and 27

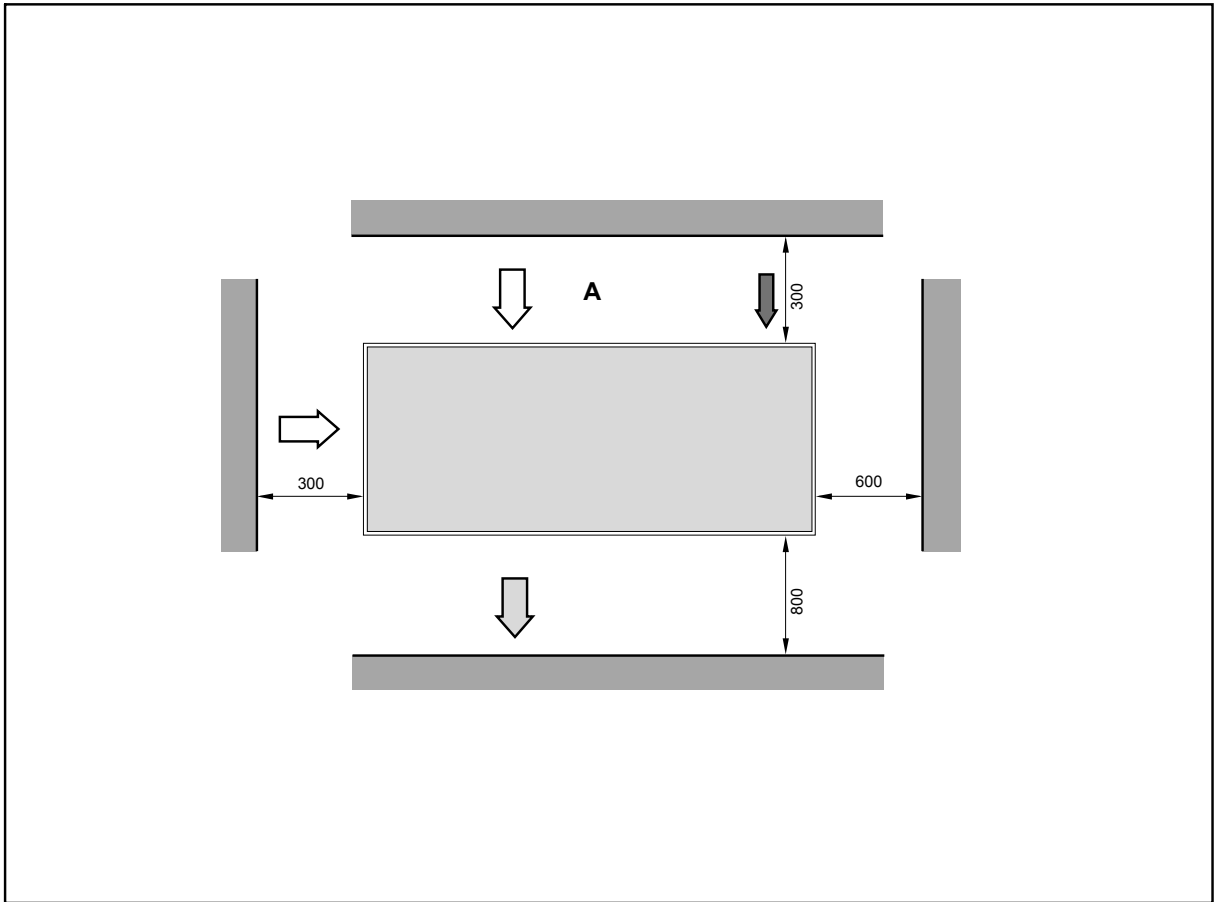

A Water inlet and outlet



NOTE

Distances in millimetres

1.6.2 Dimensions and hydraulic connections (models YLCAYLHA PLUS 5)

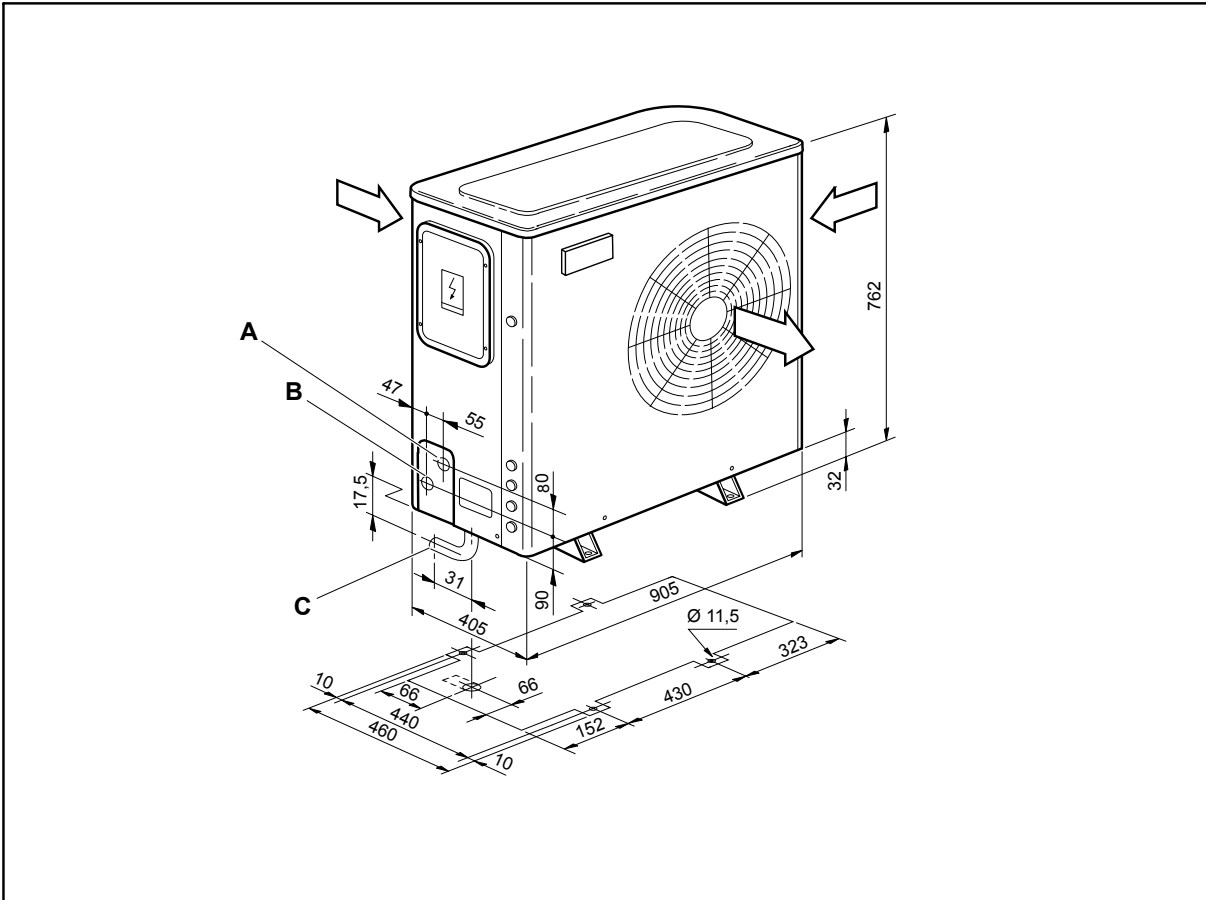

A Water inlet 1" G
B Water outlet 1" G

C Drain connection Øext. 15

1.6.3 Dimensions and hydraulic connections (models YLCA/YLHA PLUS 7 and 9)

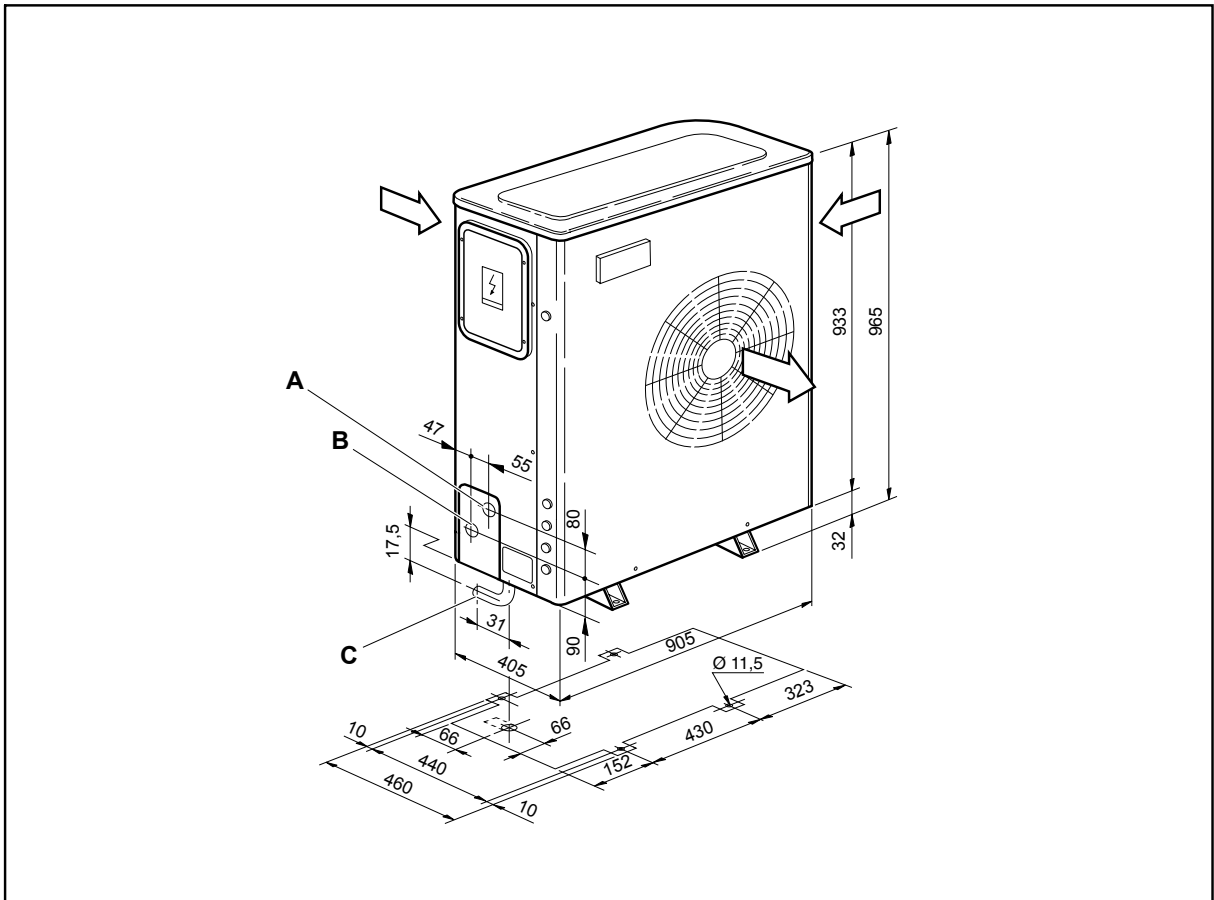

A Water inlet 1" G
B Water outlet 1" G

C Drain connection Øext. 15

1.6.4 Dimensions and hydraulic connections (models YLCAYLHA PLUS 12 and 15)

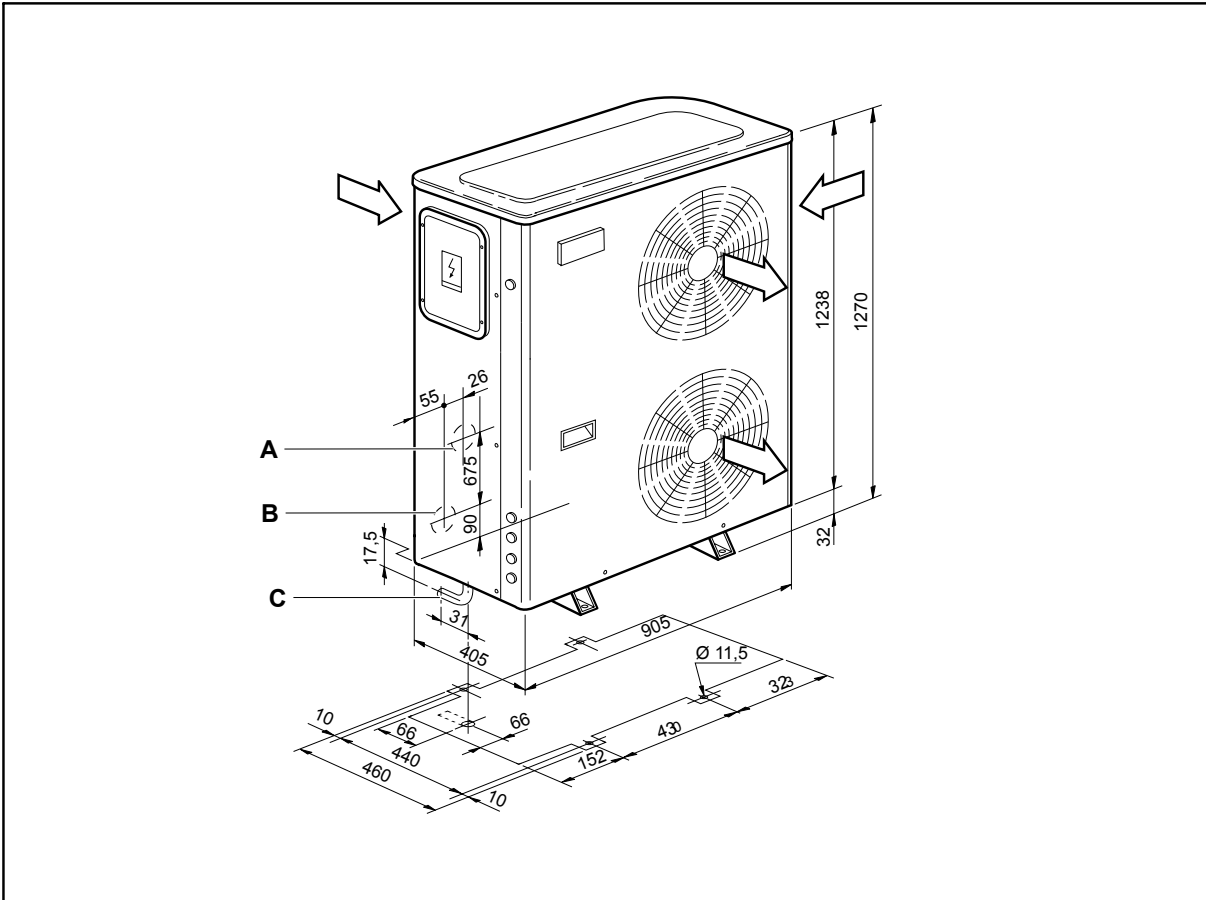

A Water inlet 1" G
B Water outlet 1" G

C Drain connection Øext. 15

1.6.5 Dimensions and hydraulic connections (models YLCA/YLHA PLUS 20 and 27)

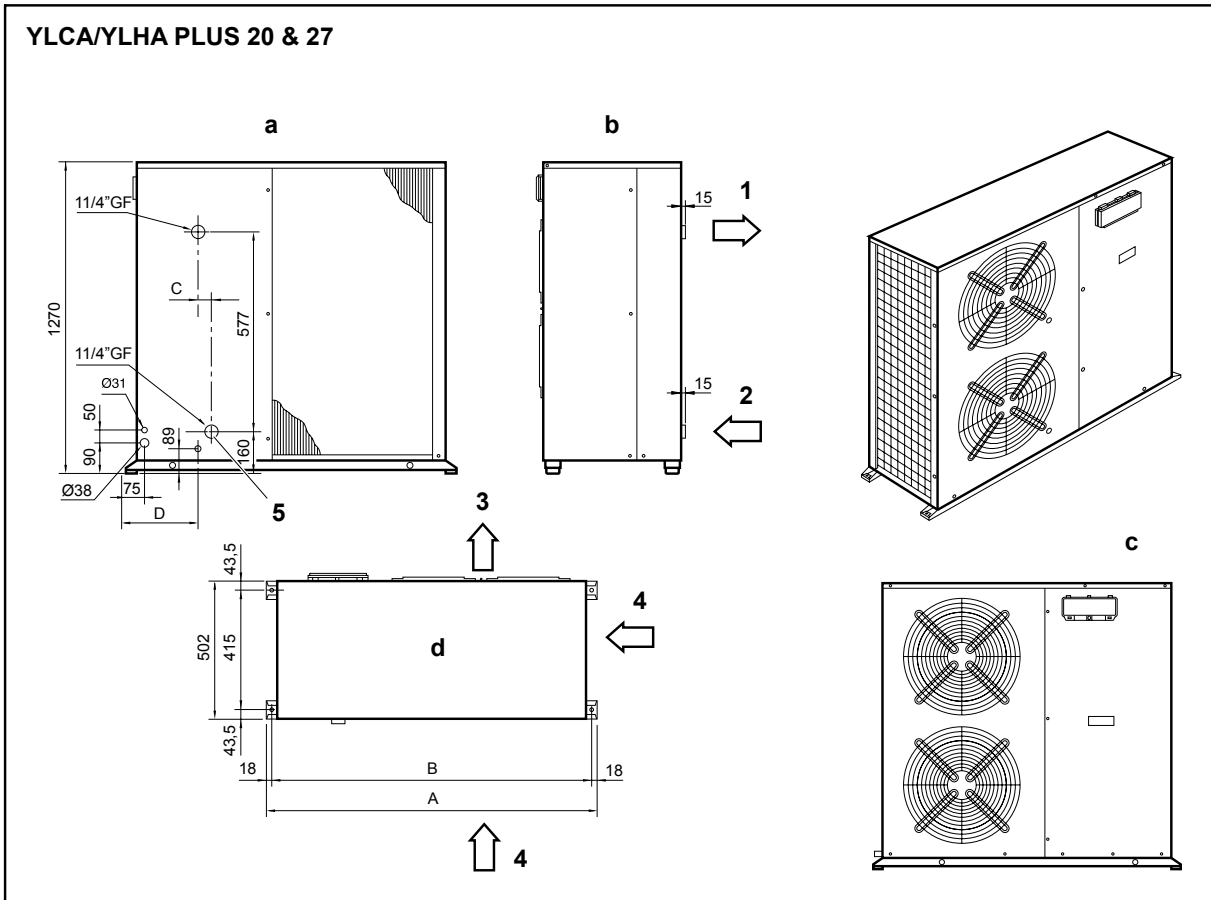

- | | | | |
|---|------------|---|----------------|
| a | Rear view | 1 | Water outlet |
| b | Side view | 2 | Water inlet |
| c | Front view | 3 | Air outlet |
| d | Upper view | 4 | Air inlet |
| | | 5 | Water drainage |

Model	A	B	C	D
YLCA/YLHA PLUS 20	1430	1394	136	428
YLCA/YLHA PLUS 27	1876	1840	144	432

1.7 Cooling capacities YLHA

1.7 Cooling capacities YLHA

1.7.1 Cooling capacities YLHA 5 ÷ 27

YLHA PLUS	Water outlet temp °C	Outdoor ambient temperature °C DB (80% RH)															
		20		25		30		32		35		40		43		46	
		Cap.	Abs. power	Cap.	Abs. power	Cap.	Abs. power	Cap.	Abs. power	Cap.	Abs. power	Cap.	Abs. power	Cap.	Abs. power	Cap.	Abs. power
		kW	kW	kW	kW	kW	kW	kW	kW	kW	kW	kW	kW	kW	kW	kW	kW
5 M	5	6,00	1,50	5,70	1,58	5,25	1,70	5,10	1,80	5,06	1,90	4,49	2,10	4,22	2,23	3,88	2,50
	6	6,25	1,50	5,80	1,59	5,45	1,71	5,29	1,81	5,23	1,90	4,77	2,11	4,47	2,23	4,07	2,50
	7	6,50	1,51	5,90	1,60	5,60	1,72	5,48	1,81	5,40	1,91	5,06	2,12	4,72	2,24	4,22	2,51
	8	6,60	1,51	6,00	1,61	5,67	1,73	5,59	1,82	5,55	1,92	5,21	2,13	4,87	2,26	4,41	2,51
	10	6,70	1,51	6,20	1,61	5,86	1,75	5,70	1,84	5,70	1,95	5,36	2,16	5,10	2,29	4,64	2,52
	12	6,80	1,52	6,40	1,62	6,01	1,76	5,86	1,85	5,82	1,97	5,51	2,19	5,32	2,32	4,98	2,52
	15	7,00	1,52	6,70	1,63	6,24	1,78	6,08	1,87	5,97	2,00	5,70	2,22	5,59	2,37	5,30	2,53
7 M	5	7,60	2,06	7,30	2,14	6,90	2,30	6,70	2,43	6,65	2,56	5,90	2,84	5,55	3,01	5,10	3,20
	6	7,75	2,07	7,45	2,15	7,10	2,31	6,95	2,44	6,88	2,57	6,28	2,85	5,88	3,02	5,35	3,24
	7	7,90	2,07	7,60	2,16	7,30	2,32	7,20	2,45	7,10	2,58	6,65	2,86	6,20	3,03	5,55	3,28
	8	8,05	2,08	7,75	2,17	7,45	2,34	7,35	2,46	7,30	2,60	6,85	2,88	6,40	3,05	5,80	3,32
	10	8,30	2,08	7,90	2,18	7,70	2,36	7,50	2,48	7,50	2,63	7,05	2,92	6,70	3,09	6,10	3,38
	12	8,55	2,09	8,20	2,19	7,90	2,38	7,70	2,50	7,65	2,66	7,25	2,96	7,00	3,14	6,55	3,42
	15	8,90	2,09	8,50	2,20	8,20	2,40	8,00	2,53	7,85	2,70	7,50	3,00	7,35	3,20	6,97	3,48
9 M	5	9,31	2,76	8,95	2,87	8,45	3,08	8,21	3,26	8,15	3,43	7,23	3,81	6,80	4,04	6,25	4,29
	6	9,50	2,78	9,13	2,88	8,70	3,10	8,52	3,27	8,42	3,45	7,69	3,82	7,20	4,04	6,56	4,35
	7	9,68	2,78	9,31	2,90	8,95	3,11	8,82	3,29	8,70	3,46	8,15	3,84	7,60	4,06	6,80	4,40
	8	9,86	2,79	9,50	2,91	9,13	3,14	9,01	3,30	8,95	3,49	8,39	3,86	7,84	4,09	7,11	4,45
	10	10,17	2,79	9,68	2,92	9,44	3,16	9,19	3,33	9,19	3,53	8,64	3,92	8,21	4,14	7,47	4,53
	12	10,48	2,80	10,05	2,94	9,68	3,19	9,44	3,35	9,37	3,57	8,88	3,97	8,58	4,21	8,03	4,59
	15	10,91	2,80	10,42	2,95	10,05	3,22	9,80	3,39	9,62	3,62	9,19	4,02	9,01	4,29	8,54	4,67
9 T	5	9,31	2,76	8,95	2,87	8,45	3,08	8,21	3,26	8,15	3,43	7,23	3,81	6,80	4,04	6,25	4,29
	6	9,50	2,78	9,13	2,88	8,70	3,10	8,52	3,27	8,42	3,45	7,69	3,82	7,20	4,04	6,56	4,35
	7	9,68	2,78	9,31	2,90	8,95	3,11	8,82	3,29	8,70	3,46	8,15	3,84	7,60	4,06	6,80	4,40
	8	9,86	2,79	9,50	2,91	9,13	3,14	9,01	3,30	8,95	3,49	8,39	3,86	7,84	4,09	7,11	4,45
	10	10,17	2,79	9,68	2,92	9,44	3,16	9,19	3,33	9,19	3,53	8,64	3,92	8,21	4,14	7,47	4,53
	12	10,48	2,80	10,05	2,94	9,68	3,19	9,44	3,35	9,37	3,57	8,88	3,97	8,58	4,21	8,03	4,59
	15	10,91	2,80	10,42	2,95	10,05	3,22	9,80	3,39	9,62	3,62	9,19	4,02	9,01	4,29	8,54	4,67
12 M	5	12,63	3,36	12,08	3,48	11,60	3,81	11,09	4,02	11,01	4,24	9,76	4,70	9,18	4,98	8,60	5,28
	6	12,90	3,37	12,33	3,50	11,90	3,82	11,50	4,04	11,38	4,25	10,38	4,71	9,72	4,99	8,85	5,32
	7	13,40	3,39	12,99	3,52	12,43	3,84	11,92	4,05	11,75	4,27	11,01	4,73	10,26	5,01	9,18	5,34
	8	13,55	3,44	12,83	3,59	12,55	3,87	12,16	4,07	12,08	4,30	11,34	4,77	10,59	5,05	9,60	5,36
	10	13,74	3,44	13,07	3,61	12,74	3,91	12,41	4,10	12,41	4,35	11,67	4,83	11,09	5,11	10,10	5,40
	12	14,15	3,46	13,57	3,62	13,07	3,94	12,74	4,14	12,66	4,40	12,00	4,90	11,58	5,20	10,84	5,44
	15	14,73	3,46	14,07	3,64	13,57	3,97	13,24	4,19	12,99	4,47	12,41	4,97	12,16	5,30	11,53	5,52
12 T	5	12,90	3,27	12,34	3,39	11,85	3,71	11,32	3,92	11,24	4,13	9,97	4,58	9,38	4,85	8,78	5,14
	6	13,17	3,28	12,59	3,41	12,15	3,72	11,75	3,93	11,62	4,14	10,61	4,59	9,93	4,86	9,04	5,18
	7	13,69	3,30	13,27	3,43	12,69	3,74	12,17	3,95	12,00	4,16	11,24	4,61	10,48	4,89	9,38	5,20
	8	13,84	3,35	13,10	3,50	12,82	3,77	12,42	3,97	12,34	4,19	11,58	4,64	10,82	4,92	9,80	5,22
	10	14,03	3,35	13,35	3,52	13,01	3,81	12,68	4,00	12,68	4,24	11,92	4,71	11,32	4,98	10,31	5,26
	12	14,45	3,37	13,86	3,53	13,35	3,84	13,01	4,03	12,93	4,29	12,25	4,77	11,83	5,06	11,07	5,30
	15	15,04	3,37	14,37	3,55	13,86	3,87	13,52	4,08	13,27	4,35	12,68	4,84	12,42	5,16	11,78	5,38
15 T	5	14,83	4,30	14,19	4,46	13,62	4,88	13,02	5,15	12,93	5,43	11,47	6,02	10,79	6,38	10,10	6,76
	6	15,15	4,32	14,48	4,48	13,98	4,90	13,51	5,17	13,36	5,45	12,20	6,03	11,42	6,39	10,40	6,82
	7	15,74	4,34	15,26	4,51	14,60	4,92	13,99	5,19	13,80	5,47	12,93	6,06	12,05	6,42	10,79	6,84
	8	15,91	4,41	15,06	4,60	14,74	4,96	14,29	5,22	14,19	5,51	13,31	6,11	12,44	6,47	11,27	6,87
	10	16,13	4,41	15,35	4,62	14,97	5,00	14,58	5,26	14,58	5,58	13,70	6,19	13,02	6,55	11,86	6,92
	12	16,62	4,43	15,94	4,64	15,35	5,05	14,97	5,30	14,87	5,64	14,09	6,28	13,61	6,66	12,73	6,97
	15	17,30	4,43	16,52	4,66	15,94	5,09	15,55	5,36	15,26	5,72	14,58	6,36	14,29	6,78	13,55	7,07

YLHA PLUS	Water outlet temp °C	Outdoor ambient temperature °C DB (80% RH)															
		20		25		30		32		35		40		43		46	
		Cap.	Abs. power	Cap.	Abs. power	Cap.	Abs. power	Cap.	Abs. power	Cap.	Abs. power	Cap.	Abs. power	Cap.	Abs. power	Cap.	Abs. power
		kW	kW	kW	kW	kW	kW	kW	kW	kW	kW	kW	kW	kW	kW	kW	kW
20 T	5	21,00	5,36	20,83	5,69	20,09	5,96	19,74	6,19	19,16	6,67	17,06	7,35	16,29	7,83	14,21	8,35
	6	22,24	5,39	21,68	5,75	20,88	6,02	20,45	6,25	19,80	7,00	17,97	7,40	17,12	7,93	16,20	8,40
	7	23,17	5,43	22,58	5,80	21,67	6,08	21,21	6,30	19,40	7,04	18,87	7,46	17,91	8,05	16,97	8,45
	8	23,89	5,46	23,25	5,83	22,30	6,14	21,73	6,36	20,86	7,08	19,31	7,52	18,27	8,11	17,26	8,50
	10	25,30	5,54	24,60	5,89	23,53	6,20	22,88	6,42	21,88	7,11	20,38	7,58	19,22	8,17	18,12	8,55
	12	26,79	5,60	25,99	5,93	24,79	6,23	24,02	6,46	22,94	7,11	21,39	7,64	20,14	8,23	18,92	8,60
	15	29,24	5,69	28,04	6,01	26,64	6,30	25,75	6,53	24,54	7,15	23,05	7,72	21,62	8,27	20,30	8,70
27 T	5	28,29	6,97	27,71	7,17	26,71	7,51	26,26	7,80	25,49	8,78	22,69	9,26	21,67	9,87	20,49	10,60
	6	29,58	7,01	28,84	7,25	27,77	7,58	27,19	7,87	26,33	8,82	23,90	9,33	22,77	10,00	21,55	10,71
	7	30,82	7,09	30,03	7,31	28,82	7,66	28,20	7,94	25,80	8,87	25,09	9,40	23,82	10,14	22,57	10,86
	8	31,77	7,12	30,92	7,34	29,66	7,73	28,90	8,01	27,74	8,92	25,68	9,47	24,30	10,22	22,95	10,98
	10	33,64	7,20	32,72	7,43	31,30	7,81	30,43	8,09	29,10	8,96	27,11	9,55	25,56	10,30	24,10	11,06
	12	35,63	7,23	34,57	7,47	32,96	7,85	31,94	8,13	30,50	8,96	28,45	9,63	26,79	10,37	25,16	11,14
	15	38,52	7,33	37,30	7,57	35,43	7,94	34,25	8,23	32,63	9,01	30,65	9,73	28,75	10,41	26,95	11,22

Abs. power = Includes compressor and fan consumption.

1.7 Cooling capacities YLHA

1.7.2 Cooling capacities YLHA 5 ÷ 27 (35% ethylene glycol)

YLHA PLUS	Water outlet temp °C	Outdoor ambient temperature °C DB (80% RH)															
		20		25		30		32		35		40		43		46	
		Cap.	Abs. power	Cap.	Abs. power	Cap.	Abs. power	Cap.	Abs. power	Cap.	Abs. power	Cap.	Abs. power	Cap.	Abs. power	Cap.	Abs. power
		kW	kW	kW	kW	kW	kW	kW	kW	kW	kW	kW	kW	kW	kW	kW	kW
5 M	-5	3,62	1,15	3,46	1,24	3,29	1,35	3,21	1,40	3,10	1,47	2,84	1,61	2,69	1,69	2,54	1,78
	-4	3,81	1,17	3,64	1,27	3,45	1,38	3,37	1,43	3,25	1,50	2,98	1,64	2,82	1,73	2,65	1,83
	-2	4,16	1,23	4,00	1,33	3,78	1,45	3,70	1,50	3,56	1,57	3,27	1,72	3,09	1,81	2,89	1,91
	0	4,51	1,29	4,38	1,39	4,16	1,51	4,04	1,56	3,89	1,64	3,57	1,80	3,38	1,89	3,13	1,99
	2	5,00	1,35	4,77	1,45	4,53	1,58	4,41	1,63	4,25	1,72	3,90	1,88	3,69	1,97	3,48	2,06
7 M	-5	4,76	1,55	4,54	1,68	4,33	1,83	4,23	1,89	4,07	1,98	3,73	2,17	3,53	2,28	3,34	2,40
	-4	5,01	1,59	4,79	1,72	4,53	1,87	4,43	1,93	4,27	2,03	3,91	2,22	3,70	2,33	3,48	2,48
	-2	5,47	1,66	5,26	1,80	4,97	1,96	4,86	2,02	4,68	2,12	4,30	2,32	4,06	2,44	3,80	2,58
	0	5,93	1,74	5,75	1,88	5,47	2,04	5,31	2,11	5,12	2,22	4,70	2,43	4,44	2,55	4,12	2,68
	2	6,57	1,82	6,27	1,96	5,95	2,13	5,80	2,20	5,59	2,32	5,13	2,54	4,85	2,67	4,58	2,79
9 M	-5	5,83	2,08	5,57	2,25	5,30	2,45	5,18	2,53	4,99	2,66	4,58	2,91	4,33	3,06	4,09	3,22
	-4	6,13	2,13	5,86	2,30	5,56	2,51	5,43	2,59	5,23	2,72	4,79	2,98	4,54	3,13	4,26	3,32
	-2	6,70	2,23	6,45	2,41	6,09	2,62	5,95	2,71	5,74	2,85	5,26	3,11	4,98	3,27	4,65	3,46
	0	7,26	2,34	7,05	2,52	6,70	2,74	6,51	2,83	6,27	2,98	5,76	3,26	5,44	3,43	5,05	3,60
	2	8,05	2,44	7,68	2,63	7,30	2,86	7,11	2,96	6,85	3,11	6,28	3,40	5,94	3,58	5,61	3,74
9 T	-5	5,83	2,08	5,57	2,25	5,30	2,45	5,18	2,53	4,99	2,66	4,58	2,91	4,33	3,06	4,09	3,22
	-4	6,13	2,13	5,86	2,30	5,56	2,51	5,43	2,59	5,23	2,72	4,79	2,98	4,54	3,13	4,26	3,32
	-2	6,70	2,23	6,45	2,41	6,09	2,62	5,95	2,71	5,74	2,85	5,26	3,11	4,98	3,27	4,65	3,46
	0	7,26	2,34	7,05	2,52	6,70	2,74	6,51	2,83	6,27	2,98	5,76	3,26	5,44	3,43	5,05	3,60
	2	8,05	2,44	7,68	2,63	7,30	2,86	7,11	2,96	6,85	3,11	6,28	3,40	5,94	3,58	5,61	3,74
12 M	-5	7,87	2,56	7,52	2,78	7,16	3,02	6,99	3,12	6,74	3,28	6,18	3,59	5,85	3,77	5,52	3,97
	-4	8,28	2,63	7,92	2,84	7,50	3,09	7,33	3,19	7,06	3,36	6,48	3,67	6,13	3,86	5,76	4,10
	-2	9,05	2,75	8,71	2,97	8,23	3,24	8,04	3,34	7,75	3,52	7,11	3,84	6,72	4,04	6,29	4,27
	0	9,81	2,88	9,52	3,11	9,05	3,38	8,79	3,49	8,47	3,67	7,77	4,02	7,35	4,23	6,82	4,44
	2	10,87	3,01	10,37	3,25	9,85	3,53	9,60	3,65	9,25	3,84	8,49	4,20	8,03	4,41	7,58	4,61
12 T	-5	8,04	2,50	7,68	2,71	7,31	2,94	7,14	3,04	6,88	3,20	6,31	3,50	5,97	3,67	5,64	3,87
	-4	8,46	2,56	8,09	2,77	7,66	3,01	7,49	3,11	7,21	3,27	6,61	3,58	6,26	3,76	5,88	3,99
	-2	9,24	2,68	8,89	2,89	8,41	3,15	8,21	3,26	7,91	3,43	7,26	3,74	6,86	3,94	6,42	4,16
	0	10,02	2,81	9,72	3,03	9,24	3,29	8,98	3,40	8,65	3,58	7,94	3,92	7,50	4,12	6,96	4,33
	2	11,10	2,93	10,59	3,16	10,06	3,44	9,81	3,56	9,45	3,74	8,67	4,09	8,20	4,30	7,74	4,49
15 T	-5	9,25	3,28	8,83	3,56	8,41	3,87	8,21	4,00	7,91	4,21	7,26	4,60	6,87	4,83	6,49	5,09
	-4	9,73	3,36	9,30	3,64	8,81	3,96	8,61	4,09	8,29	4,30	7,61	4,71	7,20	4,95	6,76	5,25
	-2	10,63	3,53	10,22	3,81	9,67	4,15	9,44	4,28	9,10	4,50	8,35	4,92	7,89	5,18	7,38	5,47
	0	11,52	3,69	11,18	3,98	10,63	4,33	10,33	4,48	9,95	4,71	9,13	5,15	8,63	5,41	8,00	5,69
	2	12,77	3,86	12,18	4,16	11,57	4,52	11,28	4,67	10,87	4,92	9,97	5,38	9,43	5,65	8,90	5,91
20 T	-5	13,00	4,22	12,42	4,58	11,82	4,98	11,55	5,15	11,12	5,41	10,20	5,92	9,65	6,22	9,12	6,55
	-4	13,68	4,33	13,08	4,69	12,39	5,10	12,10	5,27	11,66	5,54	10,69	6,06	10,12	6,37	9,51	6,76
	-2	14,94	4,54	14,37	4,90	13,59	5,34	13,28	5,51	12,79	5,80	11,74	6,33	11,10	6,66	10,38	7,04
	0	16,20	4,75	15,72	5,12	14,94	5,57	14,52	5,76	13,98	6,06	12,83	6,63	12,13	6,97	11,25	7,32
	2	17,95	4,96	17,12	5,35	16,27	5,82	15,86	6,02	15,27	6,33	14,01	6,92	13,25	7,28	12,51	7,60
27 T	-5	17,29	5,32	16,51	5,77	15,72	6,28	15,36	6,48	14,79	6,82	13,57	7,45	12,84	7,83	12,13	8,25
	-4	18,19	5,46	17,39	5,90	16,48	6,43	16,09	6,63	15,50	6,98	14,22	7,63	13,46	8,02	12,64	8,52
	-2	19,87	5,72	19,12	6,17	18,07	6,72	17,66	6,95	17,01	7,30	15,61	7,98	14,76	8,39	13,80	8,87
	0	21,54	5,99	20,90	6,45	19,87	7,02	19,31	7,26	18,59	7,63	17,07	8,35	16,13	8,78	14,96	9,22
	2	23,87	6,25	22,77	6,75	21,64	7,33	21,09	7,58	20,31	7,98	18,64	8,72	17,62	9,17	16,64	9,58
	4	25,54	6,52	24,64	7,04	23,40	7,65	22,87	7,90	22,03	8,32	20,21	9,09	19,12	9,56	18,06	10,11

Abs. power = Includes compressor and fan consumption.

1.7.3 Heating capacities YLHA 5 ÷ 27

YLHA PLUS	Water outlet temp °C	Outdoor ambient temperature °C DB (80% RH)																	
		-15		-10		-7		0		5		7		10		15		20	
		Cap.	Abs. power	Cap.	Abs. power	Cap.	Abs. power	Cap.	Abs. power	Cap.	Abs. power	Cap.	Abs. power	Cap.	Abs. power	Cap.	Abs. power	Cap.	Abs. power
		kW	kW	kW	kW	kW	kW	kW	kW	kW	kW	kW	kW	kW	kW	kW	kW	kW	kW
5 M	30	1,60	1,40	1,69	1,41	2,48	1,42	4,30	1,43	5,32	1,43	6,46	1,44	6,74	1,45	7,58	1,45	7,85	1,46
	35	1,51	1,35	1,89	1,55	2,40	1,56	4,25	1,57	5,28	1,58	6,40	1,60	6,62	1,60	7,52	1,61	7,63	1,62
	40	-	-	2,04	1,72	2,35	1,72	4,20	1,73	5,24	1,74	6,35	1,75	6,46	1,75	7,45	1,76	7,45	1,77
	45	-	-	-	-	2,32	1,91	4,15	1,88	5,19	1,89	6,30	1,90	6,45	1,91	7,39	1,92	7,32	1,92
	50	-	-	-	-	-	-	4,10	2,00	5,11	2,02	6,25	2,03	6,43	2,05	6,85	2,06	7,19	2,08
7 M	30	1,82	1,82	2,84	1,85	4,10	1,93	5,06	1,85	6,00	1,86	7,29	1,87	7,60	1,88	8,54	1,89	8,85	1,90
	35	1,70	1,75	2,83	2,03	3,87	2,11	4,95	2,04	5,95	2,06	7,21	2,07	7,46	2,08	8,47	2,09	8,60	2,10
	40	-	-	2,81	2,21	3,76	2,23	4,85	2,25	5,90	2,26	7,16	2,27	7,29	2,28	8,40	2,29	8,40	2,30
	45	-	-	-	-	3,59	2,45	4,77	2,45	5,85	2,46	7,10	2,47	7,27	2,48	8,32	2,49	8,25	2,50
	50	-	-	-	-	-	-	4,65	2,60	5,75	2,62	7,04	2,64	7,25	2,66	7,72	2,68	8,10	2,70
9 M	30	2,41	2,00	3,52	2,05	5,09	2,13	6,69	2,20	8,04	2,20	9,77	2,21	10,19	2,22	11,46	2,23	12,28	2,25
	35	2,28	2,20	3,51	2,23	4,81	2,33	6,58	2,46	7,98	2,48	9,67	2,49	10,00	2,50	11,36	2,52	12,05	2,53
	40	-	-	3,49	2,43	4,67	2,54	6,46	2,72	7,91	2,76	9,59	2,77	9,77	2,78	11,26	2,80	11,81	2,81
	45	-	-	-	-	4,45	2,74	6,34	2,97	7,85	3,09	9,52	3,15	9,74	3,16	11,16	3,18	11,58	3,18
	50	-	-	-	-	-	-	6,22	3,20	7,71	3,21	9,45	3,31	9,72	3,32	10,36	3,33	11,42	3,35
9 T	30	2,41	2,00	3,52	2,05	5,09	2,13	6,69	2,20	8,04	2,20	9,77	2,21	10,19	2,22	11,46	2,23	12,28	2,25
	35	2,28	2,20	3,51	2,23	4,81	2,33	6,58	2,46	7,98	2,48	9,67	2,49	10,00	2,50	11,36	2,52	12,05	2,53
	40	-	-	3,49	2,43	4,67	2,54	6,46	2,72	7,91	2,76	9,59	2,77	9,77	2,78	11,26	2,80	11,81	2,81
	45	-	-	-	-	4,45	2,74	6,34	2,97	7,85	3,09	9,52	3,15	9,74	3,16	11,16	3,18	11,58	3,18
	50	-	-	-	-	-	-	6,22	3,20	7,71	3,21	9,45	3,31	9,72	3,32	10,36	3,33	11,42	3,35
12 M	30	3,11	2,40	4,75	2,50	6,78	2,60	8,20	2,72	10,35	2,74	12,57	2,75	13,11	2,76	14,74	2,78	15,80	2,80
	35	2,93	2,70	4,73	2,80	6,41	2,90	8,06	3,08	10,26	3,09	12,44	3,10	12,86	3,11	14,62	3,13	15,50	3,15
	40	-	-	4,71	3,00	6,24	3,10	7,90	3,42	10,18	3,44	12,35	3,45	12,57	3,46	14,49	3,48	15,20	3,50
	45	-	-	-	-	5,95	3,40	7,80	3,70	10,10	3,85	12,25	3,92	12,54	3,94	14,36	3,95	14,90	3,96
	50	-	-	-	-	-	-	7,70	3,90	9,93	4,00	12,15	4,12	12,51	4,13	13,33	4,15	14,70	4,17
12 T	30	3,15	2,86	3,66	2,86	5,08	2,87	8,33	2,88	10,51	2,90	12,77	2,91	13,31	2,92	14,97	2,94	16,05	2,96
	35	2,98	3,23	3,45	3,24	4,77	3,33	8,19	3,26	10,42	3,27	12,64	3,28	13,06	3,29	14,84	3,31	15,74	3,33
	40	-	-	3,25	3,49	4,57	3,49	8,02	3,62	10,34	3,64	12,54	3,65	12,77	3,66	14,71	3,68	15,44	3,71
	45	-	-	-	-	4,27	3,65	7,92	3,92	10,25	4,08	12,44	4,15	12,73	4,17	14,58	4,18	15,13	4,19
	50	-	-	-	-	-	-	7,82	4,13	10,08	4,23	12,34	4,36	12,70	4,37	13,53	4,39	14,93	4,41
15 T	30	4,08	3,50	6,05	3,56	8,75	3,57	10,78	3,58	13,60	3,61	16,52	3,62	17,23	3,63	19,38	3,66	20,77	3,69
	35	3,85	3,80	6,02	3,87	8,26	4,03	10,59	4,05	13,49	4,07	16,35	4,08	16,91	4,09	19,21	4,12	20,37	4,15
	40	-	-	6,00	4,22	8,02	4,41	10,38	4,50	13,38	4,53	16,23	4,54	16,52	4,55	19,04	4,58	19,98	4,61
	45	-	-	-	-	7,65	4,75	10,25	4,87	13,27	5,07	16,10	5,16	16,48	5,18	18,88	5,20	19,58	5,21
	50	-	-	-	-	-	-	10,12	5,13	13,05	5,27	15,97	5,42	16,44	5,44	17,52	5,46	19,32	5,49
20 T	30	8,55	4,25	10,29	4,32	14,87	4,48	18,60	4,80	19,40	4,85	20,66	4,90	22,81	4,56	25,15	4,65	26,30	4,77
	35	8,30	4,70	9,68	4,77	13,27	4,97	18,15	5,26	19,26	5,32	20,49	5,41	22,63	5,60	24,94	5,99	25,87	5,25
	40	-	-	9,08	5,27	12,15	5,50	16,80	5,90	18,48	5,96	20,31	6,04	22,45	6,12	24,72	6,57	25,45	5,75
	45	-	-	-	-	10,82	5,99	15,41	6,49	17,78	6,56	20,14	6,60	22,23	6,46	24,50	6,50	25,02	6,55
	50	-	-	-	-	-	-	14,09	7,00	16,92	7,05	19,79	7,10	21,37	6,57	22,74	6,62	24,60	6,72
27 T	30	11,25	5,20	13,43	5,35	19,42	5,83	23,80	6,15	25,17	6,25	26,98	6,38	30,01	5,91	33,09	6,03	35,90	6,25
	35	10,92	5,90	12,94	6,04	17,32	6,47	23,50	6,85	25,12	6,92	26,75	7,04	29,78	7,26	32,81	7,77	34,80	6,80
	40	-	-	12,45	6,73	15,87	7,16	21,94	7,68	24,21	7,76	26,53	7,86	29,54	7,93	32,53	8,52	34,00	7,45
	45	-	-	-	-	14,86	7,73	20,12	8,45	23,23	8,54	26,30	8,59	29,25	8,37	32,24	8,42	33,50	8,49
	50	-	-	-	-	-	-	18,41	9,11	22,12	9,18	25,85	9,24	28,12	8,51	29,92	8,58	32,80	9,15

Integrated heating capacity includes the defrost cycles

Abs. power = Includes compressor and fan consumption.

1.8 Cooling capacity YLCA

1.8.1 Cooling capacities YLCA 5 ÷ 27

YLCA	Water outlet temp °C	Outdoor ambient temperature °C DB (80% RH)															
		20		25		30		32		35		40		43		46	
		Cap.	Unit	Cap.	Unit	Cap.	Unit	Cap.	Unit	Cap.	Unit	Cap.	Unit	Cap.	Unit	Cap.	Unit
		kW	kW	kW	kW	kW	kW	kW	kW	kW	kW	kW	kW	kW	kW	kW	kW
5	5	5,71	1,59	5,55	1,63	5,31	1,70	5,18	1,76	4,99	1,85	4,41	2,06	4,18	2,18	3,92	2,33
	6	5,93	1,59	5,76	1,64	5,52	1,71	5,38	1,77	5,18	1,86	4,68	2,07	4,43	2,21	4,18	2,35
	7	6,15	1,60	5,98	1,65	5,73	1,72	5,59	1,77	5,38	1,87	4,95	2,08	4,69	2,23	4,44	2,38
	8	6,31	1,60	6,14	1,65	5,89	1,73	5,74	1,78	5,53	1,88	5,11	2,09	4,84	2,24	4,58	2,39
	10	6,65	1,61	6,48	1,66	6,21	1,74	6,06	1,79	5,83	1,89	5,44	2,10	5,15	2,25	4,88	2,40
	12	6,99	1,61	6,82	1,66	6,54	1,74	6,38	1,79	6,14	1,89	5,76	2,11	5,46	2,26	5,17	2,41
	15	7,50	1,62	7,33	1,67	7,03	1,75	6,86	1,80	6,60	1,90	6,26	2,12	5,93	2,26	5,62	2,42
7	5	7,11	2,18	6,99	2,24	6,69	2,32	6,66	2,40	6,28	2,53	5,49	2,86	5,21	3,04	4,78	3,27
	6	7,39	2,18	7,25	2,24	6,95	2,33	6,92	2,41	6,52	2,54	5,83	2,87	5,52	3,07	5,10	3,29
	7	7,58	2,19	7,50	2,27	7,22	2,35	7,19	2,42	7,13	2,58	6,17	2,88	5,84	3,11	5,41	3,33
	8	7,86	2,19	7,73	2,27	7,42	2,36	7,38	2,44	7,29	2,59	6,37	2,90	6,03	3,12	5,58	3,36
	10	8,28	2,20	8,16	2,27	7,82	2,37	7,79	2,45	7,45	2,60	6,78	2,91	6,42	3,14	5,95	3,37
	12	8,71	2,20	8,59	2,28	8,23	2,37	8,20	2,45	7,73	2,61	7,18	2,92	6,80	3,15	6,30	3,39
	15	9,34	2,22	9,23	2,28	8,85	2,38	8,82	2,46	8,31	2,62	7,80	2,94	7,39	3,15	6,85	3,40
9	5	8,61	2,60	8,80	2,89	8,33	2,99	8,06	3,09	7,60	3,30	6,65	3,69	6,30	3,93	5,78	4,22
	6	8,94	2,61	9,13	2,90	8,66	3,01	8,37	3,11	7,89	3,31	7,06	3,71	6,68	3,94	6,17	4,24
	7	9,86	2,62	9,44	2,91	8,99	3,03	8,70	3,13	8,63	3,33	7,46	3,72	7,07	3,95	6,55	4,26
	8	9,51	2,63	9,73	2,92	9,24	3,04	8,93	3,15	8,81	3,35	7,71	3,73	7,30	3,96	6,76	4,28
	10	10,03	2,66	10,27	2,94	9,74	3,05	9,43	3,19	9,00	3,37	8,20	3,75	7,77	3,98	7,20	4,32
	12	10,54	2,68	10,81	2,96	10,26	3,06	9,93	3,23	9,36	3,39	8,69	3,77	8,23	4,00	7,63	4,36
	15	11,31	2,71	11,62	2,99	11,02	3,08	10,67	3,29	10,06	3,45	9,44	3,80	8,94	4,07	8,47	4,39
12	5	12,37	3,06	12,15	3,43	11,63	3,80	11,58	3,88	10,93	4,13	9,55	4,62	9,06	4,92	8,31	5,28
	6	12,85	3,08	12,61	3,45	12,09	3,82	12,03	3,90	11,34	4,15	10,14	4,64	9,60	4,97	8,86	5,30
	7	13,78	3,10	13,49	3,47	12,97	3,84	12,50	3,92	12,40	4,17	10,72	4,66	10,16	5,03	9,41	5,32
	8	14,03	3,12	13,82	3,49	13,15	3,86	12,83	3,94	12,65	4,19	11,07	4,68	10,49	5,05	9,71	5,34
	10	14,41	3,16	14,19	3,53	13,60	3,90	13,55	3,96	12,90	4,21	11,79	4,70	11,16	5,07	10,35	5,36
	12	15,14	3,20	14,93	3,57	14,32	3,92	14,26	3,96	13,44	4,22	12,48	4,73	11,83	5,09	10,96	5,38
	15	16,25	3,26	16,05	3,63	15,39	3,95	15,34	3,98	14,45	4,23	13,56	4,75	12,85	5,11	11,54	5,40
15	5	14,47	4,54	14,21	4,67	13,60	4,84	13,54	5,00	12,78	5,33	11,17	5,96	10,59	6,35	9,72	6,81
	6	15,02	4,56	14,75	4,69	14,13	4,86	14,07	5,03	13,26	5,35	11,86	5,99	11,22	6,41	10,36	6,87
	7	15,42	4,57	15,25	4,71	14,68	4,89	14,61	5,05	14,50	5,38	12,54	6,01	11,88	6,19	11,01	6,95
	8	15,99	4,59	15,72	4,72	15,08	4,92	15,01	5,08	14,16	5,41	12,95	6,04	12,26	6,52	11,36	7,01
	10	16,85	4,59	16,59	4,73	15,90	4,95	15,84	5,11	14,93	5,43	13,78	6,07	13,05	6,54	12,10	7,03
	12	17,71	4,61	17,46	4,75	16,75	4,97	16,68	5,11	15,72	5,44	14,59	6,10	13,83	6,57	12,82	7,06
	15	19,00	4,62	18,77	4,76	18,00	5,00	17,93	5,14	16,90	5,46	15,86	6,12	15,02	6,60	13,94	7,09
20	5	21,41	5,45	20,97	5,61	20,22	5,87	19,88	6,10	19,29	6,87	17,18	7,24	16,40	7,72	15,51	8,29
	6	22,39	5,48	21,93	5,67	21,02	5,93	20,58	6,16	19,40	6,90	18,90	7,30	17,24	7,82	16,31	8,38
	7	23,33	5,54	22,73	5,72	21,82	5,99	21,35	6,21	19,52	6,94	18,99	7,36	18,03	7,94	17,08	8,50
	8	24,05	5,57	23,40	5,75	22,45	6,05	21,88	6,27	21,00	6,98	18,44	7,41	18,40	8,00	17,37	8,59
	10	25,47	5,64	24,77	5,81	23,69	6,11	23,03	6,33	22,03	7,01	20,52	7,47	19,35	8,06	18,25	8,66
	12	26,97	5,65	26,17	5,85	24,95	6,14	24,18	6,36	23,09	7,01	21,54	7,54	20,28	8,11	19,05	8,72
	15	29,16	5,74	28,23	5,92	26,82	6,21	25,92	6,44	24,70	7,05	23,20	7,61	21,76	8,15	20,40	8,78
27	5	28,60	6,90	27,49	7,53	25,77	8,17	26,05	8,64	24,28	8,99	22,52	9,48	21,50	10,10	19,60	10,97
	6	30,03	7,00	28,61	7,58	26,81	8,24	26,98	8,71	24,94	9,03	23,72	9,55	22,60	10,23	21,38	11,02
	7	30,62	7,11	29,32	7,63	27,63	8,33	27,98	8,78	25,60	9,08	24,90	9,62	23,63	10,39	22,39	11,07
	8	32,21	7,22	30,68	7,76	28,69	8,53	28,68	8,86	27,52	9,18	25,48	9,70	24,11	10,46	22,77	11,12
	10	34,07	7,30	32,47	7,84	30,32	8,61	30,19	8,93	28,88	9,28	26,90	9,77	25,36	10,54	23,92	11,22
	12	36,04	7,42	34,30	7,89	31,97	8,65	31,69	8,98	30,27	9,43	28,23	9,86	26,58	10,62	24,97	11,32
	15	38,59	7,54	37,01	7,99	34,42	8,74	33,98	9,08	32,38	9,58	30,41	9,96	28,53	10,66	26,96	11,47

1.8.2 Cooling capacities YLCA 5 ÷ 27 (35% ethylene glycol)

YLCA	Water outlet temp °C	Outdoor ambient temperature °C DB (80% RH)															
		20		25		30		32		35		40		43		46	
		Cap.	Unit	Cap.	Unit	Cap.	Unit	Cap.	Unit	Cap.	Unit	Cap.	Unit	Cap.	Unit	Cap.	Unit
		kW	kW	kW	kW	kW	kW	kW	kW	kW	kW	kW	kW	kW	kW	kW	kW
5	-5	3,60	1,12	3,44	1,22	3,28	1,32	3,20	1,37	3,08	1,44	2,83	1,57	2,68	1,65	2,53	1,74
	-4	3,79	1,15	3,63	1,24	3,44	1,35	3,36	1,40	3,23	1,47	2,97	1,61	2,81	1,69	2,64	1,80
	-2	4,14	1,21	3,99	1,30	3,77	1,42	3,68	1,46	3,55	1,54	3,25	1,68	3,08	1,77	2,88	1,87
	0	4,49	1,26	4,36	1,36	4,14	1,48	4,03	1,53	3,88	1,61	3,56	1,76	3,36	1,85	3,12	1,94
	2	4,98	1,32	4,75	1,42	4,51	1,55	4,40	1,60	4,24	1,68	3,89	1,84	3,67	1,93	3,47	2,02
	4	5,33	1,37	5,14	1,48	4,88	1,61	4,77	1,67	4,59	1,75	4,21	1,92	3,99	2,01	3,77	2,13
7	-5	4,49	1,53	4,34	1,66	4,13	1,81	4,12	1,87	3,88	1,96	3,52	2,18	3,34	2,30	3,08	2,44
	-4	4,73	1,57	4,57	1,70	4,33	1,85	4,31	1,91	4,07	2,01	3,69	2,23	3,50	2,36	3,21	2,52
	-2	5,16	1,65	5,02	1,78	4,75	1,94	4,73	2,00	4,47	2,10	4,05	2,33	3,83	2,47	3,51	2,62
	0	5,60	1,72	5,49	1,86	5,22	2,02	5,18	2,09	4,88	2,20	4,43	2,44	4,19	2,58	3,80	2,73
	2	6,20	1,80	5,98	1,94	5,68	2,11	5,65	2,18	5,33	2,30	4,84	2,55	4,58	2,69	4,23	2,83
	4	6,64	1,88	6,47	2,03	6,14	2,20	6,13	2,28	5,78	2,40	5,25	2,66	4,97	2,81	4,59	2,99
9	-5	5,78	2,00	5,52	2,17	5,26	2,36	5,14	2,43	4,95	2,56	4,54	2,80	4,29	2,94	4,06	3,10
	-4	6,08	2,05	5,82	2,22	5,51	2,41	5,38	2,49	5,19	2,62	4,76	2,87	4,50	3,01	4,23	3,20
	-2	6,65	2,15	6,39	2,32	6,05	2,52	5,91	2,61	5,69	2,74	5,22	2,99	4,94	3,15	4,62	3,33
	0	7,21	2,25	6,99	2,42	6,65	2,64	6,46	2,73	6,22	2,87	5,71	3,13	5,40	3,30	5,01	3,46
	2	7,98	2,35	7,62	2,53	7,24	2,75	7,05	2,85	6,79	2,99	6,23	3,27	5,89	3,44	5,57	3,60
	4	8,54	2,45	8,24	2,64	7,83	2,87	7,65	2,97	7,37	3,12	6,76	3,41	6,39	3,59	6,04	3,80
12	-5	8,31	2,50	7,94	2,71	7,56	2,95	7,38	3,05	7,11	3,21	6,52	3,50	6,17	3,68	5,83	3,88
	-4	8,74	2,56	8,36	2,78	7,92	3,02	7,74	3,12	7,45	3,28	6,83	3,59	6,47	3,77	6,08	4,00
	-2	9,55	2,69	9,19	2,90	8,69	3,16	8,49	3,27	8,18	3,43	7,50	3,75	7,09	3,95	6,63	4,17
	0	10,35	2,81	10,05	3,03	9,55	3,30	9,28	3,41	8,94	3,59	8,20	3,92	7,75	4,13	7,19	4,34
	2	11,47	2,94	10,94	3,17	10,40	3,45	10,13	3,56	9,76	3,75	8,96	4,10	8,47	4,31	8,00	4,50
	4	12,28	3,06	11,84	3,31	11,25	3,60	10,99	3,71	10,59	3,91	9,71	4,28	9,19	4,49	8,68	4,75
15	-5	9,72	3,23	9,28	3,50	8,84	3,81	8,63	3,93	8,31	4,14	7,63	4,52	7,22	4,75	6,82	5,00
	-4	10,22	3,31	9,77	3,58	9,26	3,90	9,05	4,02	8,71	4,23	7,99	4,63	7,56	4,86	7,11	5,16
	-2	11,17	3,47	10,74	3,74	10,16	4,08	9,92	4,21	9,56	4,43	8,77	4,84	8,29	5,09	7,76	5,38
	0	12,11	3,63	11,75	3,92	11,17	4,26	10,85	4,40	10,45	4,63	9,59	5,06	9,06	5,33	8,41	5,60
	2	13,41	3,79	12,80	4,09	12,16	4,45	11,85	4,60	11,42	4,84	10,47	5,29	9,90	5,56	9,35	5,81
	4	14,36	3,95	13,85	4,27	13,15	4,64	12,85	4,79	12,38	5,05	11,36	5,52	10,74	5,80	10,15	6,13
20	-5	13,61	3,86	13,05	4,20	12,48	4,60	12,25	4,77	11,74	5,34	10,94	5,54	10,42	5,85	9,87	6,21
	-4	14,39	3,98	13,78	4,31	13,08	4,73	12,82	4,89	11,87	5,46	11,38	5,69	10,79	6,01	10,14	6,42
	-2	15,79	4,19	15,19	4,53	14,37	4,97	14,03	5,15	13,47	5,72	12,38	5,97	11,70	6,31	10,92	6,71
	0	17,20	4,41	16,66	4,76	15,81	5,21	15,30	5,40	14,65	5,97	13,42	6,26	12,64	6,62	11,67	7,00
	2	19,20	4,62	18,22	5,01	17,21	5,47	16,66	5,67	15,93	6,24	14,53	6,57	13,65	6,94	12,79	7,29
	4	20,71	4,86	19,79	5,26	18,62	5,74	18,02	5,95	17,20	6,51	15,62	6,89	14,63	7,26	13,67	7,72
27	-5	17,84	5,05	17,10	5,50	16,36	6,01	16,06	6,24	15,56	6,98	14,34	7,25	13,66	7,66	12,93	8,12
	-4	18,86	5,20	18,07	5,64	17,15	6,18	16,80	6,40	16,61	7,14	14,91	7,45	14,14	7,87	13,30	8,40
	-2	20,70	5,49	19,92	5,93	18,83	6,50	18,40	6,73	17,66	7,48	16,23	7,81	15,33	8,26	14,31	8,78
	0	22,55	5,77	21,84	6,23	20,72	6,81	20,06	7,07	19,21	7,81	17,60	8,20	16,56	8,66	15,29	9,16
	2	25,17	6,05	23,88	6,55	22,56	7,16	21,84	7,42	20,88	8,16	19,05	8,60	17,89	9,08	16,76	9,54
	4	27,14	6,36	25,94	6,89	24,41	7,51	23,62	7,78	22,54	8,52	20,47	9,01	19,18	9,50	17,92	10,10

1.9 Instructions for installation and connection of the unit

1.9.1 Characteristics of the location

Before locating the unit, make sure you have received the appropriate product by checking the specifications described on the outside of same.

The unit should be placed on a perfectly horizontal plane, making sure the base can support the weight of the unit.

If vibration-free operation is required, the unit can be placed on a cork or similar anti-vibratory base, or fastened to the base with anti-vibratory plates or supports.

Location of various units

Avoid recirculation of air between units.

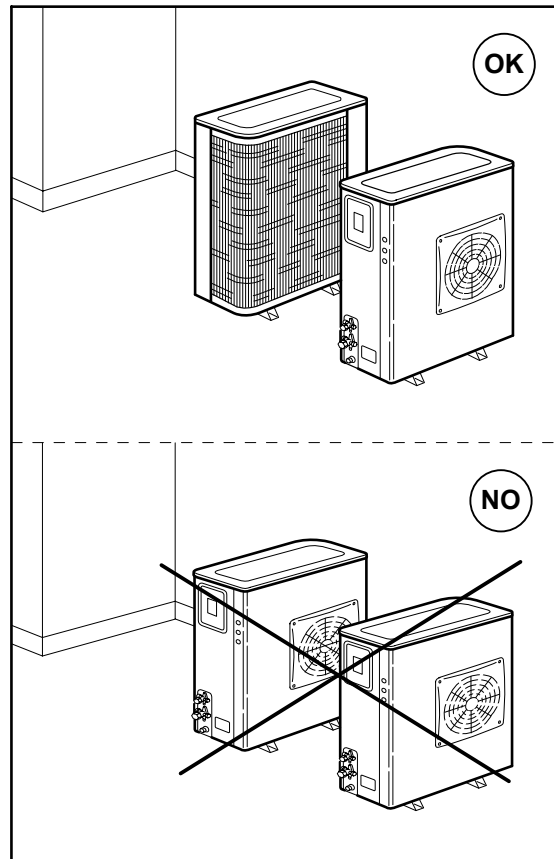

1.9.2 Specifications for anchoring the unit

Before installing the unit, make sure the structure can support the weight of same. If the unit is to be placed on the floor, a concrete base should be prepared so as to distribute weight evenly.

Place the unit on top of a firm base and secure it with bolts through the four holes on the base.

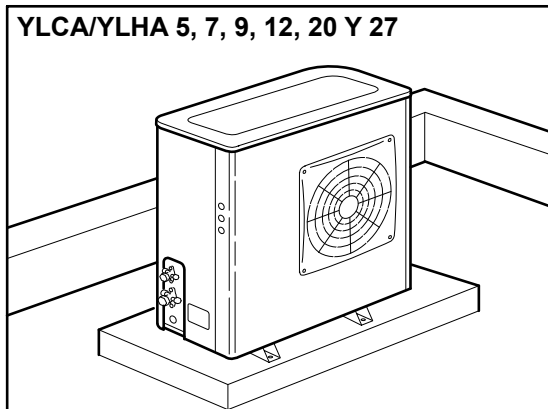

Areas with regular snowfall

If the unit is mounted outdoors at ground level, it should be lifted onto supports to prevent a build-up of snow from obstructing the passage of air. These supports must be above the level normally reached by the snow. Anti-snow grilles should be fitted.

- A Without anti-snow grilles (low platform)
- B With anti-snow grilles (low platform)

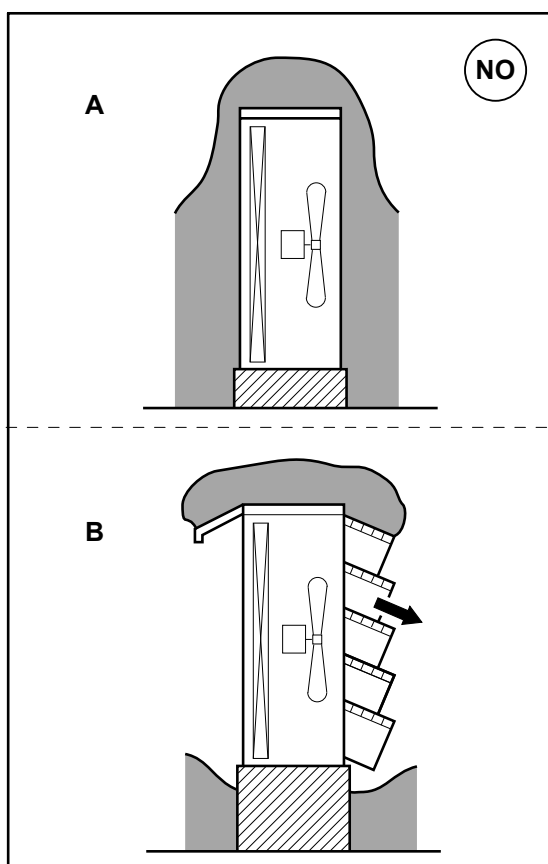

Orientation

Turn the unit to face the prevailing wind.

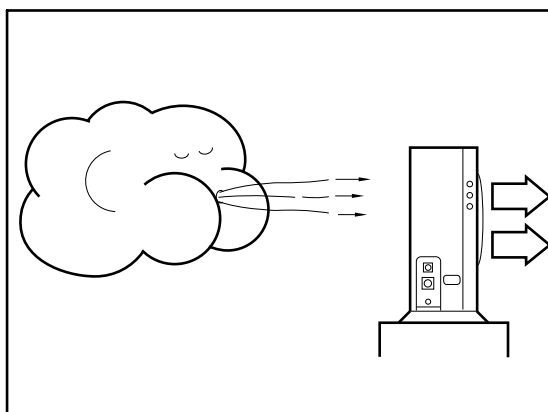

1.9 Instructions for installation and connection of the unit

1.9.3 Hydraulic connections

The hydraulic connections of the water inlet and outlet of the unit should be carried out respecting the inlet and outlet directions indicated.

Galvanised iron or copper piping can be used, with dimensions no lower than those indicated, and keeping in mind the pressure drops at said connections and in the internal exchanger of the installation.

Pump dimensioning should be carried out in accordance with a nominal flow rate that allows an f_{c} within the operating limits.

During the winter season, with outdoor temperatures below 0 °C, take precautions to avoid freezing of the water in the pipes.

Usually, a filling solution is applied to the circuit with an antifreeze mixture (glycol).

1.9.4 Wiring diagrams

Electrical installation YLCA / YLHA PLUS 5 to 27

- | | | | |
|----|---|---|---|
| A | YLCA terminal strip | b | Flow Switch (only in units without hydraulic group) |
| B | Outdoor terminal strip | c | General alarm (voltage-free inverter contact max. 2A resist. A 230 Vac) |
| C | Main switch | d | Remote ON / OFF switch |
| a1 | Supply (200 - 1+ N - ph - 50 Hz) (Single-phase units) | e | Remote COOL / HEAT switch
CLOSED = COOL
OPEN = HEAT (YLHA units only) |
| a3 | Supply (400 - 3 + N - ph - 50 Hz) (Three-phase units) | f | Auxiliary heater |

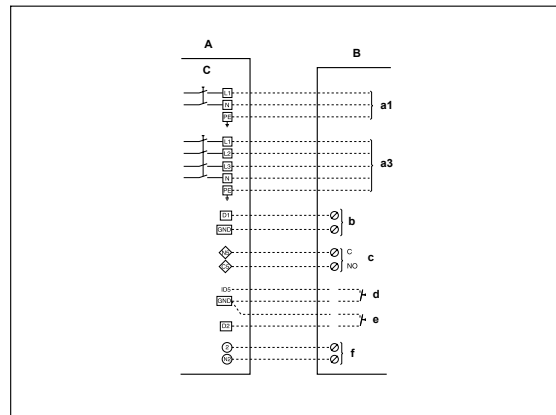

- | | | | |
|---|-------------------------------------|-------|---|
| □ | Terminal strips
YLCA / YLHA PLUS | ◇ | Voltage-free terminal strip contact
YLCA / YLHA PLUS |
| ∅ | Outdoor unit terminals | - - - | Client's electrical installation |
| ○ | 230 Vac terminal | | |

CAUTION

The cable used for the unit power supply must be H05 RN - F

1.10 Instructions for starting up the unit

1.10.1 Rotational direction of Scroll compressors

The Scroll compressors only operate correctly in one direction of rotation. Although these units are protected by a phase order detector, when the unit is started, check that the unit rotates in the correct direction. If it is not correct:

If the compressors are not connected correctly and are rotating in the wrong direction:

- The compressor will not compress.
- Operating noise will be abnormal.
- Electricity consumption (A) will be low.
- They overheat.

The phase detector must have both LEDs lit for correct operation:

- Green LED lit means: Power ON.
- Yellow LED lit means: Relay ON.

1.11 Unit sound pressure data

YLCA-YLHA Plus models

YLCA-YLHA Plus models							
Frequency (Hz)	5	7	9	12	15	20	27
125 Hz	66,2	66,2	74	79,6	79,6	77	75,6
250 Hz	70,5	70,5	72,3	74,3	74,3	72,4	81,3
500 Hz	67,7	67,7	67,9	70,2	70,2	72,9	75,9
1000 Hz	65,7	65,7	66,1	67,5	67,5	69,1	70,8
2000 Hz	60,2	60,2	61,8	62,7	62,7	63,9	68,6
4000 Hz	55,1	55,1	56,3	57,7	57,7	58,2	63,3
8000 Hz	48,8	48,8	52,3	51	51	52,5	55,7
Sound power level dB (A)	70	70	71	73	73	74	78

The data given in this table are sound power values in accordance with ISO EN3743.

1.12 Unit installation data

1.12.1 List of tests for unit start-up

Please complete the following forms to register the full details of the installation and the start-up inspection.

Complete the blank fields or mark the appropriate box, as applicable.

Company performing installation:

Company performing installation:	
Installing technician:	
Name / project number:	
Location of the unit:	
Address of the unit location:	
Person in charge of the building or property where the unit is installed:	
Installation work start date:	
Unit model number:	
Unit serial number:	
Plate and version:	
Thermostat, model and version:	

General inspection of the unit

	Visual appearance
	Levelling of the unit
	Check the unit for transport, loading and unloading damage
	Unit installed with sufficient clearance
	Check the circuit for the presence of oil (large coolant leaks).
	Terminals and connections correctly secured in the control panel and accessories
	Air filters installed
	Condensate drain pipe and drain trap installed correctly
	Thermostat and connection cabling installed correctly
	Air duct installation complete and correct
	Accessories and planned options installed (if applicable)

Inspection of the air supply fan

	Drive belt and pulleys aligned and correctly fastened
	Drive belt tension correctly adjusted
	Verification of direction of rotation

Inspection of compressors

	Verification that direction of rotation is correct
--	--

1.12.2 Start-up Data

Electrical data

	Specifications Plate	Actual
Power supply	Check specifications in the Installation Manual	
Control voltage		
Fan consumption (A)		
Consumption of condenser fan 1 (A)		
Consumption of condenser fan 2 (A)		
Consumption of compressor 1 (A)		
Consumption of compressor 2 (A)		
Consumption of supply fan (A)		
Electric heater 1 (Optional)		
Electric heater 2 (Optional)		

Cool and heat modes

Coolant circuit. Compressor 1		
Mode	Value	
Subcooling (min. 8 K, max. 18 K)	°C	Liquid pressure: ____ bar
		Liquid temperature: ____ °C
Overheating (min. 4 K, max. 10 K)	°C	Suction pressure: ____ bar
		Suction temperature: ____ °C
	Complete liquid line checked in sight glass	
	Correct oil level checked in sight glass	

Coolant circuit. Compressor 2		
Mode	Value	
Subcooling (min. 8 K, max. 18 K)	°C	Liquid pressure: ____ bar
		Liquid temperature: ____ °C
Overheating (min. 4 K, max. 10 K)	°C	Suction pressure: ____ bar
		Suction temperature: ____ °C
	Complete liquid line checked in sight glass	
	Correct oil level checked in sight glass	

Air flow rate values

	m ³ /h
Design	
Measured	

Air temperature

Mode (cool or heat):	Temperature (°C)
Outdoor air:	
Supply air:	
Return air:	
Indoor air mix (if economiser is fitted):	

2

Electric circuit diagrams

2.1 Electric circuit diagram YLCA/YLHA PLUS 5÷9 MC and M (230.1.50)

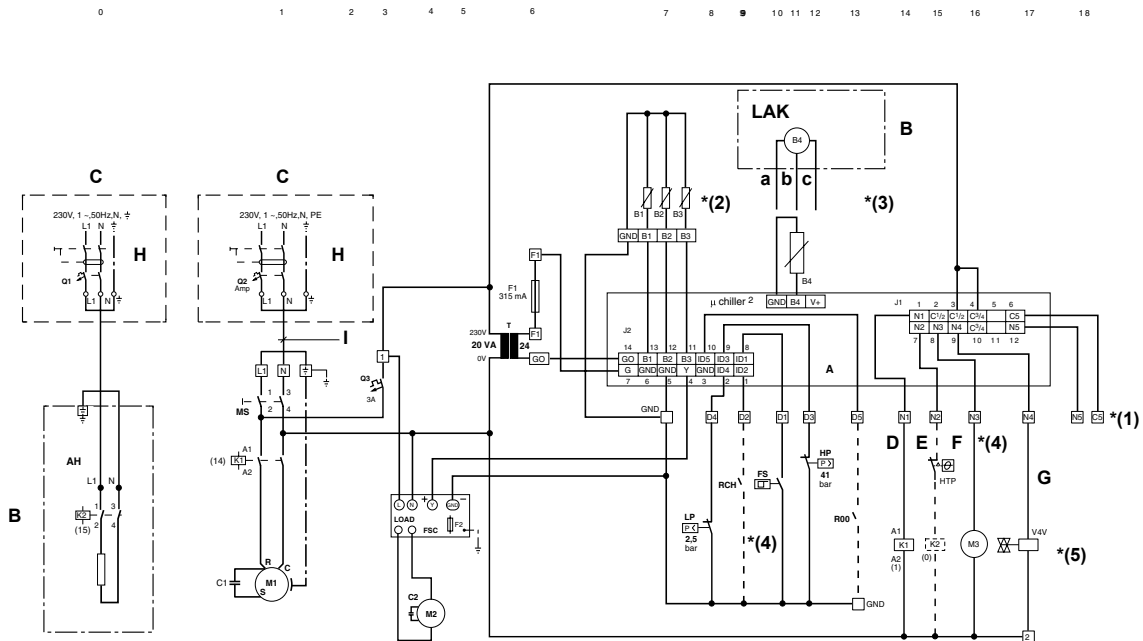

1-2531h
YLCA/YLHA PLUS 5, 7, 9 MC and M
230.1.50

UNIT	Q2	I
5	20	2,5
7	25	4
9	35	6

- * (1) Alarm. contact normally open free of voltage (maximum 3A.resistive)
- * (2) Outdoor temperature probe in units with LAK (NTC)
Battery temperature probe in standard units (NTC)
- * (3) Ratiometric pressure transducer in units with LAK
Outdoor temperature probe in standard units (NTC)
- * (4) Only MC units
- * (5) Only YLHA units

a	Green wire	FS	Water flow switch (MC units)
b	White wire	FSC	Fan speed controller
c	Black wire	HTP	Heater thermal protection
A	Electronic control	HP	High-pressure switch (41 bar)
B	The components in the box are standard accessories supplied by the manufacturer	K1	Compressor contactor
C	The components in the box are not supplied by the manufacturer	K2	Auxiliary heater contactor
D, M1	Compressor	LAK	Presostatic low ambient kit accessory
E, AH	Auxiliary heater	LP	Low pressure switch (2,5 bar)
F, M3	Pump (MC units)	L1	Line phase
H	Install on site	M2	Fan motor
I	"B" mm ² Cu	MS	Main switch
AH	Auxiliary heater	N	Neutral
B1	Water inlet temperature probe (NTC)	Q1	Thermal magnetic protector
B2	Water outlet temperature probe (NTC)	Q2	General / compressor thermal magnetic protector
B3	Temperature probe *(2)	Q3	General thermal magnetic protector, 230V / fan / pump / crankcase heater
B4	*(3)	R00	Remote ON / OFF switch
C1	Compressor condenser	RCH	Remote COOL / HEAT switch
C2	Fan condenser	T	Transformer 230 / 24V 20 VA
F1	Electronic control protection fuse / 24 V [315 mA SLOW] switching	V4V, G	4-way valves (on YLHA only)
F2	Fan speed controller fuse		

a	Green wire	FSC	Fan speed controller
b	White wire	HTP	Heater thermal protection
c	Black wire	HP	High-pressure switch (41 bar)
A	Electronic control	K1	Compressor contactor
B	The components in the box are standard accessories supplied by the manufacturer	K2	Auxiliary heater contactor
C	The components in the box are not supplied by the manufacturer	LAK	Presostatic low ambient kit accessory
D, M1	Compressor	LP	Low pressure switch (2,5 bar)
E, AH	Auxiliary heater	L1	Line voltage
F, M4	Pump (MC units)	M2, M3	Fan motors
H	Install on site	MS	Main switch
I	10 mm ² Cu	N	Phase
B1	Water inlet temperature probe (NTC)	Q1	Auxiliary heater thermal magnetic protector
B2	Water outlet temperature probe (NTC)	Q2	General / compressor thermal magnetic protector
B3	Temperature probe *(2)	Q3	General thermal magnetic protector, 230V / fan / pump / crankcase heater
B4	*(3)	Q4	Pump thermal magnetic protector (MC units)
C1	Compressor condenser	R00	Remote ON / OFF switch
C2, C3	Fan condensers	RCH	Remote COOL / HEAT switch
F1	Electronic control protection fuse / 24 V [315 mA SLOW] switching	T	Transformer 230 / 24V 20 VA
F2	Fan speed controller fuse	V4V, G	4-way valves (on YLHA only)
FS	Water flow switch (MC units)		

2.3 Electric circuit diagram YLCA/YLHA PLUS 7 and 9 TC and T (400.3.50)

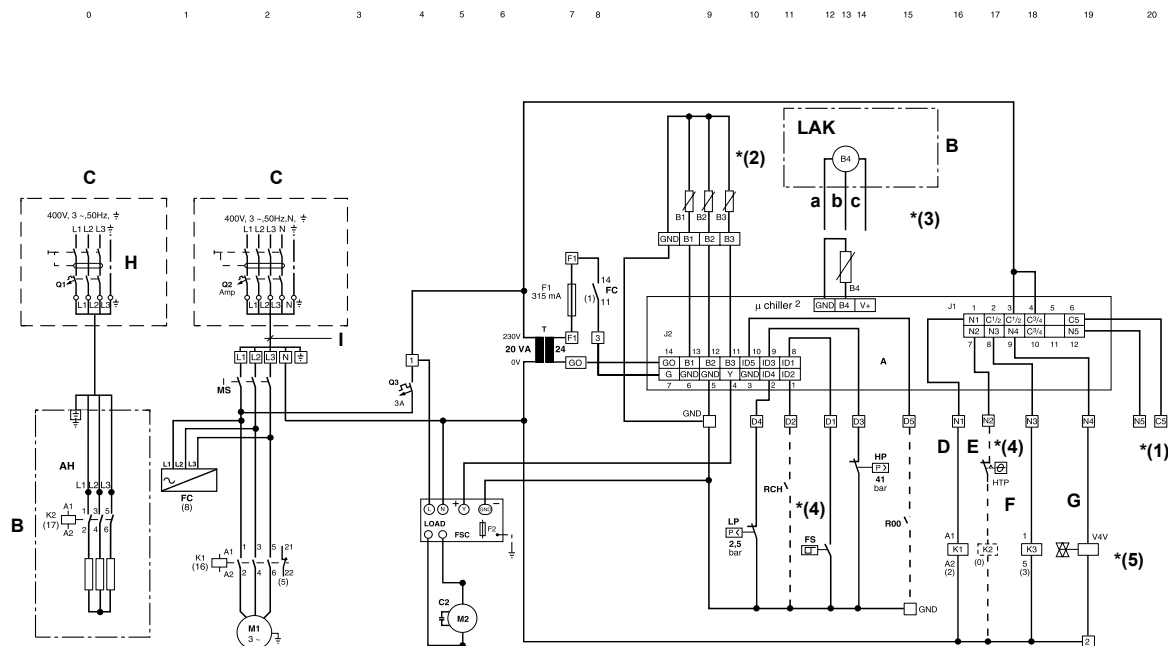

I-2545g
YLCA/YLHA PLUS 7, 9 TC and T
400.3.50

UNIT	Q2	I
7	10	2,5
9	10	2,5

- * (1) Alarm. Contact normally open free of voltage (maximum 3A.resistive)
- * (2) Outdoor temperature probe in units with LAK (NTC)
Battery temperature probe in standard units (NTC)
- * (3) Ratiometric pressure transducer in units with LAK
Outdoor temperature probe in standard units (NTC)
- * (4) Only TC units
- * (5) Only YLHA units

a	Green wire	FS	Water flow switch (TC units)
b	White wire	FSC	Fan speed controller
c	Black wire	HTP	Heater thermal protection
A	Electronic control	HP	High-pressure switch (41 bar)
B	The components in the box are standard accessories supplied by the manufacturer	K1	Compressor contactor
C	The components in the box are not supplied by the manufacturer	K2	Auxiliary heater contactor
D, M1	Compressor	LAK	Presostatic low ambient kit accessory
E, AH	Auxiliary heater	LP	Low pressure switch (2,5 bar)
F, M3	Pump (TC units)	L1, L2, L3	Line phases
H	Install on site	M2	Fan motor
I	"B" mm ² Cu	MS	Main switch
AH	Auxiliary heater	N	Neutral
B1	Water inlet temperature probe (NTC)	Q1	Auxiliary heater thermal magnetic protector
B2	Water outlet temperature probe (NTC)	Q2	General / compressor thermal magnetic protector
B3	Temperature probe *(2)	Q3	General thermal magnetic protector, 230V / fan / pump / crankcase heater
B4	*(3)	R00	Remote ON / OFF switch
C2	Fan condenser	RCH	Remote COOL / HEAT switch
F1	Electronic control protection fuse / 24 V [315 mA SLOW] switching	T	Transformer 230 / 24V 20 VA
F2	Fan speed controller fuse	V4V, G	4-way valves (on YLHA only)
FC	Phase control		

2.4 Electric circuit diagram YLCA/YLHA PLUS 12 and 15 TC and T (400.3.50)

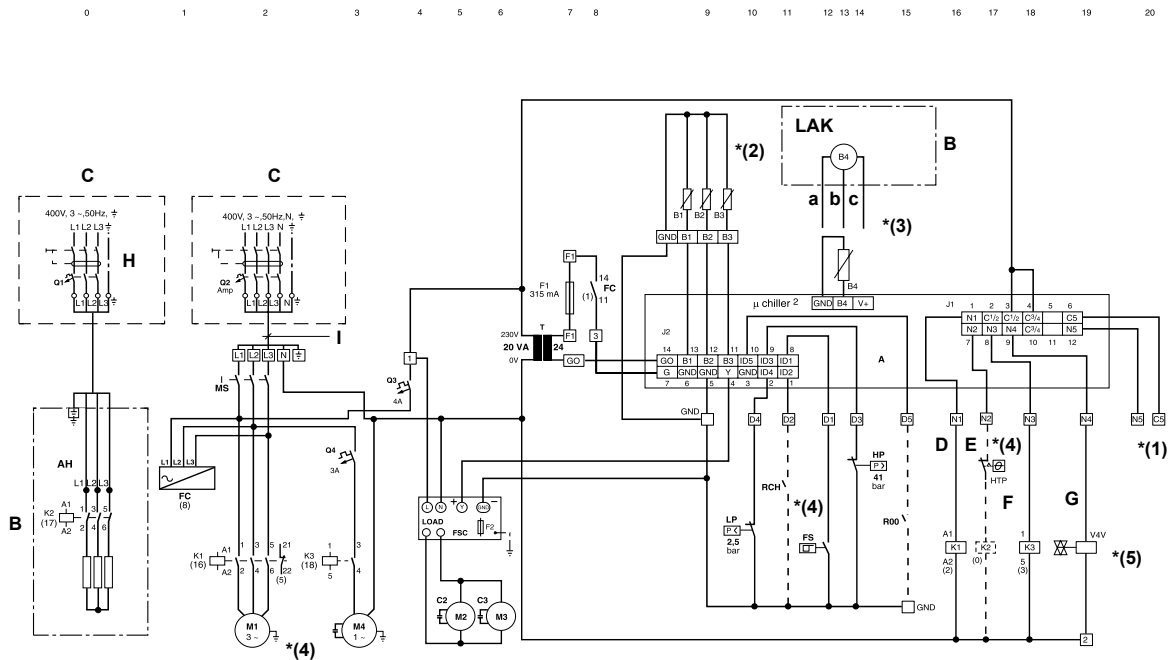

I-2533
YLCA/YLHA PLUS 12, 15 TC and T
400.3.50

UNIT	Q2	I
12	16	2,5
15	16	2,5

- * (1) Alarm. Contact normally open free of voltage (maximum 3A.resistive)
- * (2) Outdoor temperature probe in units with LAK (NTC)
Battery temperature probe in standard units (NTC)
- * (3) Ratiometric pressure transducer in units with LAK
Outdoor temperature probe in standard units (NTC)
- * (4) Only TC units
- * (5) Only YLHA units

a	Green wire	FSC	Fan speed controller
b	White wire	HTP	Heater thermal protection
c	Black wire	HP	High-pressure switch (41 bar)
A	Electronic control	K1	Compressor contactor
B	The components in the box are standard accessories supplied by the manufacturer	K2	Auxiliary heater contactor
C	The components in the box are not supplied by the manufacturer	K3	Pump contactor (TC units)
D, M1	Compressor	LAK	Presostatic low ambient kit accessory
E, AH	Auxiliary heater	LP	Low pressure switch (2,5 bar)
F, M4	Pump (TC units)	L1, L2, L3	Line phases
H	Install on site	M2, M3	Fan motor 1 and 2
I	"B" mm ² Cu	MS	Main switch
AH	Auxiliary heater	N	Neutral
B1	Water inlet temperature probe (NTC)	Q1	Auxiliary heater thermal magnetic protector
B2	Water outlet temperature probe (NTC)	Q2	General / compressor thermal magnetic protector
B3	Temperature probe *(2)	Q3	General thermal magnetic protector, 230V / fan / pump / crankcase heater
B4	*(3)	Q4	Pump magneto-thermal protector (TC units)
C2, C3	Fan condenser	R00	Remote ON / OFF switch
F1	Electronic control protection fuse / 24 V [315 mA SLOW] switching	RCH	Remote COOL / HEAT switch
F2	Fan speed controller fuse	T	Transformer 230 / 24V 20 VA
FC	Phase control	V4V, G	4-way valves (on YLHA only)
FS	Water flow switch (TC units)		

2.5 Electric circuit diagram YLCA/YLHA PLUS 20 TC and T (400.3.50)

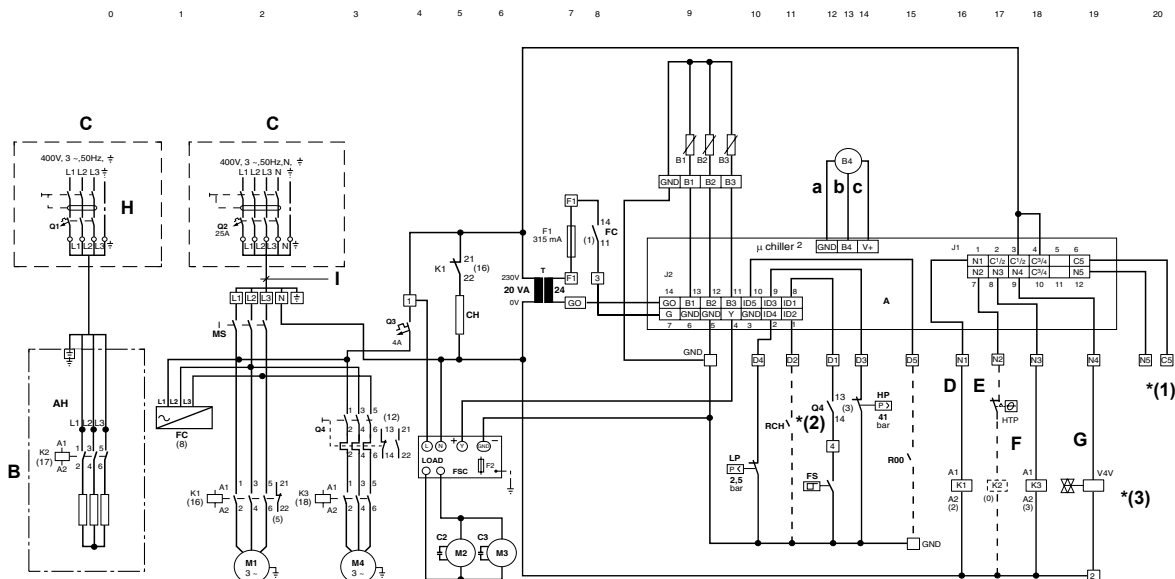

I-2534g
YLCA/YLHA PLUS 20 TC and T
400.3.50

- * (1) Alarm. Contact normally open free of voltage (maximum 3A.resistive)
- * (2) Only TC units
- * (3) Only YLHA units

a	Green wire	FS	Water flow switch (TC units)
b	White wire	FSC	Fan speed controller
c	Black wire	HTP	Heater thermal protection
A	Electronic control	HP	High-pressure switch (41 bar)
B	The components in the box are standard accessories supplied by the manufacturer	K1	Compressor contactor
C	The components in the box are not supplied by the manufacturer	K2	Auxiliary heater contactor
D, M1	Compressor	K3	Pump contactor (TC units)
E, AH	Auxiliary heater	LAK	Presostatic low ambient kit accessory
F, M4	Pump (TC units)	LP	Low pressure switch (2,5 bar)
H	Install on site	L1, L2, L3	Line phases
I	4 mm ² Cu	M2, M3	Fan motor 1 and 2
AH	Auxiliary heater	MS	Main switch
B1	Water inlet temperature probe (NTC)	N	Neutral
B2	Water outlet temperature probe (NTC)	Q1	Auxiliary heater thermal magnetic protector
B3	Outdoor temperature probe (NTC)	Q2	General / compressor thermal magnetic protector
B4	Fan / defrost speed control ratiometric pressure probe	Q3	General thermal magnetic protector, 230V / fan / pump / crankcase heater
C2, C3	Fan condenser	Q4	Pump magneto-thermal protector (TC units)
CH	Compressor crankcase heater	R00	Remote ON / OFF switch
F1	Electronic control protection fuse / 24 V [315 mA SLOW] switching	RCH	Remote COOL / HEAT switch
F2	Fan speed controller fuse	T	Transformer 230 / 24V 20 VA
FC	Phase control	V4V, G	4-way valves (on YLHA only)

2.6 Electric circuit diagram YLCA 27 TC, YLHA PLUS 27 (400.3.50)

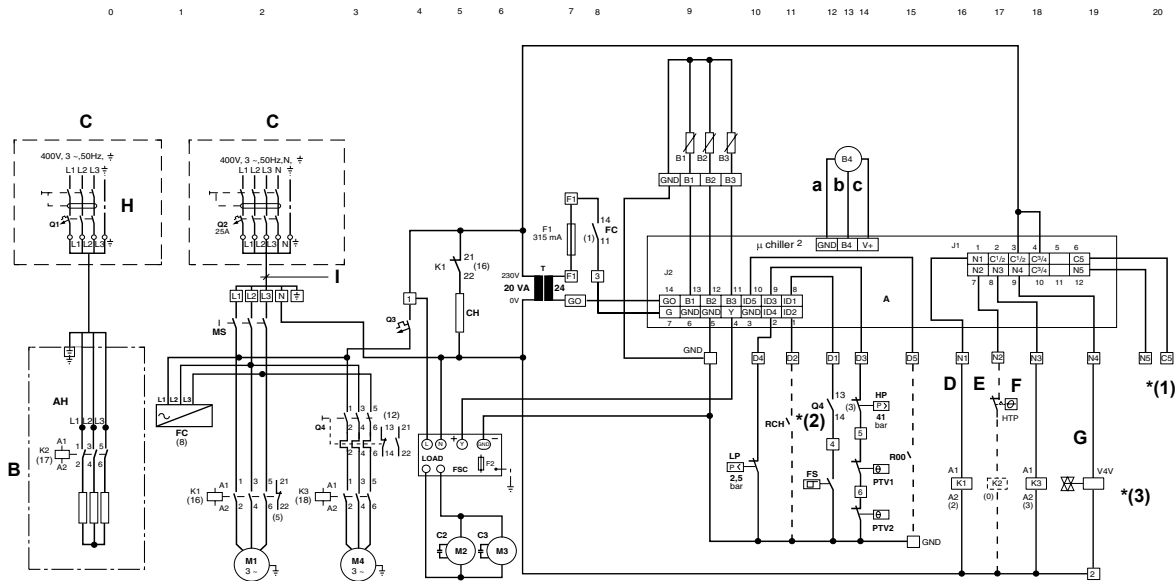

I-25651
YLCA 27 TC
YLHA PLUS 27
400.3.50

- * (1) Alarm. Contact normally open free of voltage (maximum 3A.resistive)
- * (2) Only TC units
- * (3) Only YLHA units

a	Green wire	FSC	Fan speed controller
b	White wire	HTP	Heater thermal protection
c	Black wire	HP	High pressure switch (41 bar)
A	Electronic control	K1	Compressor contactor
B	The components in the box are standard accessories supplied by the manufacturer	K2	Auxiliary heater contactor
C	The components in the box are not supplied by the manufacturer	K3	Pump contactor (TC units)
D, M1	Compressor	LAK	Presostatic low ambient kit accessory
E, AH	Auxiliary heater	LP	Low pressure switch (2,5 bar)
F, M4	Pump (TC units)	L1, L2, L3	Line phases
H	Install on site	M2, M3	Fan motor 1 and 2
I	8 mm ² Cu	MS	Main switch
AH	Auxiliary heater	N	Neutral
B1	Water inlet temperature probe (NTC)	PTV1, PTV2	Fan heat switch
B2	Water outlet temperature probe (NTC)	Q1	Auxiliary heater thermal magnetic protector
B3	Outdoor temperature probe (NTC)	Q2	General / compressor thermal magnetic protector
B4	Fan / defrost speed control ratiometric pressure probe	Q3	General thermal magnetic protector, 230V / fan / pump / crankcase heater
C2, C3	Fan condenser	Q4	Pump magneto-thermal protector (TC units)
CH	Compressor crankcase heater	R00	Remote ON / OFF switch
F1	Electronic control protection fuse / 24 V [315 mA SLOW] switching	RCH	Remote COOL / HEAT switch
F2	Fan speed controller fuse	T	Transformer 230 / 24V 20 VA
FC	Phase control	V4V, G	4-way valves (on YLHA only)
FS	Water flow switch (TC units)		

2.7 Electric circuit diagram YLCA PLUS 5 ÷ 9 MCS (230.1.50) SOFT START

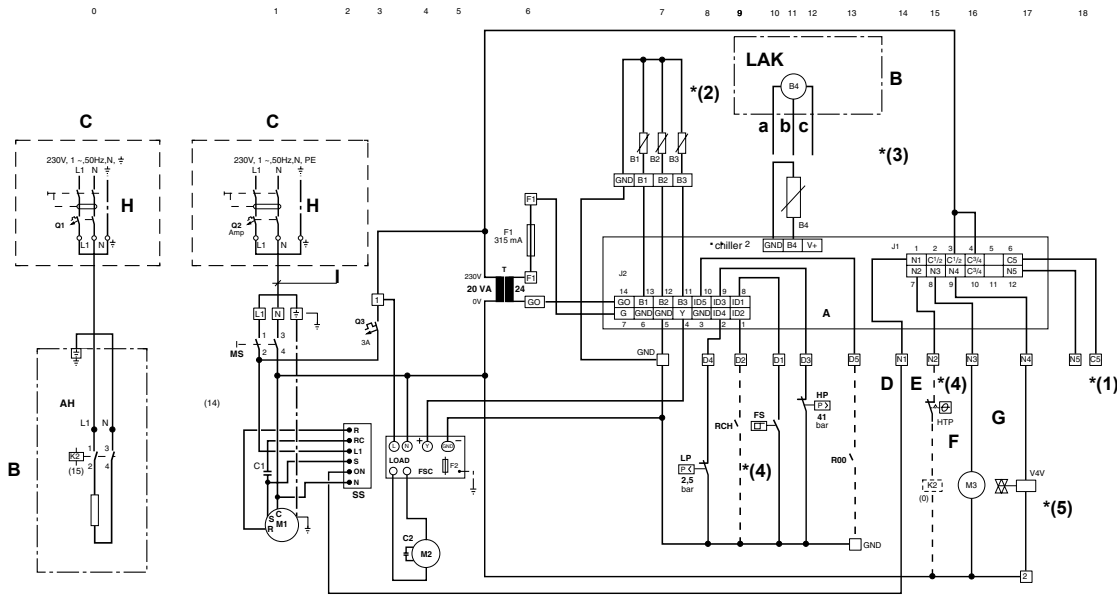

I-2582b
YLHA PLUS 5, 7, 9 MCS
230.1.50

UNIT	Q2	I
5	20	2,5
7	25	4
9	32	6

- * (1) Alarm. contact normally open free of voltage (maximum 3A.resistive)
- * (2) Outdoor temperature probe in units with LAK (NTC)
Battery temperature probe in standard units (NTC)
- * (3) Ratiometric pressure transducer in units with LAK
Outdoor temperature probe in standard units (NTC)
- * (4) Only MC units
- * (5) Only YLHA units

a	Green wire	F2	Fan speed controller fuse
b	White wire	FS	Water flow switch (MC units)
c	Black wire	FSC	Fan speed controller
A	Electronic control	HTP	Heater thermal protection
B	The components in the box are standard accessories supplied by the manufacturer	HP	High-pressure switch (41 bar)
C	The components in the box are not supplied by the manufacturer	K2	Auxiliary heater contactor
D, M1	Compressor	LAK	Presostatic low ambient kit accessory
E, AH	Auxiliary heater	LP	Low pressure switch (2,5 bar)
F, M3	Pump (MC units)	L1	Line phase
H	Install on site	M2	Fan motor
I	"B" mm ² Cu	MS	Main switch
AH	Auxiliary heater	N	Neutral
B1	Water inlet temperature probe (NTC)	Q1	Thermal magnetic protector
B2	Water outlet temperature probe (NTC)	Q2	General / compressor thermal magnetic protector
B3	Temperature probe *(2)	Q3	General thermal magnetic protector, 230V / fan / pump / crankcase heater
B4	*(3)	R00	Remote ON / OFF switch
C1	Compressor condenser	RCH	Remote COOL / HEAT switch
C2	Fan condenser	T	Transformer 230 / 24V 20 VA
F1	Electronic control protection fuse / 24 V [315 mA SLOW] switching	V4V, G	4-way valves (on YLHA only)

2.8 Electric circuit diagram YLCA PLUS 12 MCS (230.1.50) SOFT START

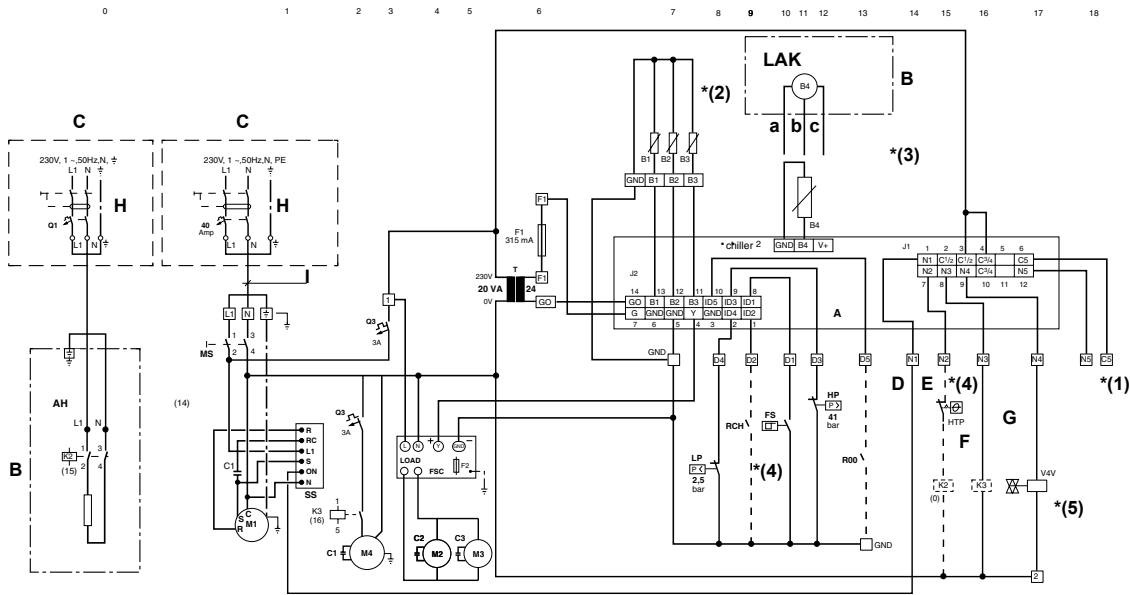

I-2583d
YLCA PLUS 12 MCS
230.1.50

- * (1) Alarm. contact normally open free of voltage (maximum 3A.resistive)
- * (2) Outdoor temperature probe in units with LAK (NTC)
Battery temperature probe in standard units (NTC)
- * (3) Ratiometric pressure transducer in units with LAK
Outdoor temperature probe in standard units (NTC)
- * (4) Only MC units
- * (5) Only YLHA units

a	Green wire	FSC	Fan speed controller
b	White wire	HTP	Heater thermal protection
c	Black wire	HP	High-pressure switch (41 bar)
A	Electronic control	K2	Auxiliary heater contactor
B	The components in the box are standard accessories supplied by the manufacturer	K3	Pump contactor (TC units)
C	The components in the box are not supplied by the manufacturer	LAK	Presostatic low ambient kit accessory
D, M1	Compressor	LP	Low pressure switch (2,5 bar)
E, AH	Auxiliary heater	L1	Line phase
F, M4	Pump (MC units)	M2, M3	Fan motor
H	Install on site	MS	Main switch
I	10 mm ² Cu	N	Neutral
AH	Auxiliary heater	Q1	Auxiliary heater thermal magnetic protector
B1	Water inlet temperature probe (NTC)	Q2	General / compressor thermal magnetic protector
B2	Water outlet temperature probe (NTC)	Q3	General thermal magnetic protector, 230V / fan / pump / crankcase heater
B3	Temperature probe *(2)	R00	Remote ON / OFF switch
B4	*(3)	RCH	Remote COOL / HEAT switch
C2, C3	Fan condenser	SS	Gentle starter
F1	Electronic control protection fuse / 24 V [315 mA SLOW] switching	T	Transformer 230 / 24V 20 VA
F2	Fan speed controller fuse	V4V, G	4-way valves (on YLHA only)
FS	Water flow switch (MC units)		