



Austausch der Zündgasleitung NG-31E, NG-1P
Seite 3



Replacing the ignition gas line NG-31E
Page 4



Remplacement de la conduite de gaz d'allumage NG-31E
Page 5



Sostituzione del tubo del gas d'accensione NG-31E
Pagina 6



Замена газопровода запальной горелки на газовых котлах NG-31E, NG-1P
Стр. 7

D

Hinweise für den Austausch von Einzelkomponenten an Wolf Gasheizkesseln



Der Austausch von einzelnen Komponenten des Kessels und der Heizungsanlage ist durch einen qualifizierten Installateur vorzunehmen.



Vor den Arbeiten am Heizkessel muß dieser außer Betrieb genommen werden und der Gasabsperrhahn geschlossen sein.

Beim Austausch einer der Komponenten wie Gaskombiventil, Zündbrenner, oder Zündbrennerdüse ist auch jeweils die Zündgasleitung mit auszutauschen.

Beim Wechsel des Gaskombiventils ist dieses gemäß der Montageanleitung (Abschnitt Gaskombiventil/Inbetriebnahme) des Kessels auf den richtigen Düsendruck einzustellen.

Austausch der Zündbrennerdüse:

Beim Austausch der Zündbrennerdüse ist die richtige Düse entsprechend der Gasart einzubauen:

	NG-31E	NG-1P
Erdgas:	Düse mit Kennung 4	Düse mit Kennung 5
Flüssiggas:	Düse mit Kennung 225	Düse mit Kennung 25

Austausch der Zündgasleitung:

Die alte Zündgasleitung demontieren.

1. Die entsprechende Verschraubung Gaskombiventil auswählen und handfest in das Gaskombiventil einschrauben.

NG-31E-70:	M10
NG-31E-90/-110; NG-1P:	M11

2. Die Zündgasleitung bis zum Anschlag in das Gaskombiventil einschieben und Verschraubung anziehen (Drehmoment 10Nm).
3. Die flexible Zündgasleitung biegen (die alte Zündgasleitung als Vorlage benutzen).
4. Die Verschraubung Zündbrenner und den Klemmring auf die Zündgasleitung schieben.
5. Die Zündgasleitung bis zum Anschlag in den Zündbrenner einschieben und Verschraubung anziehen (Drehmoment 10Nm). Dabei am Sechskant der flexiblen Zündgasleitung gegenhalten um ein Verdrehen der Leitung zu verhindern.

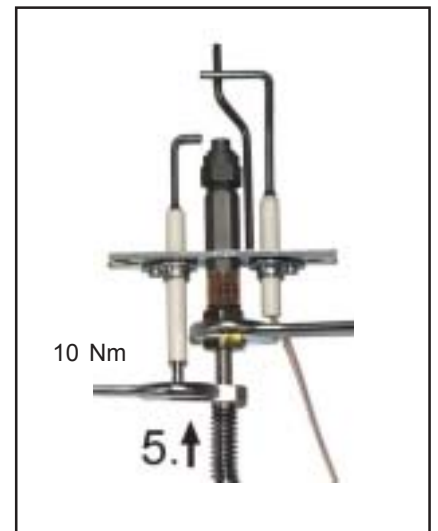
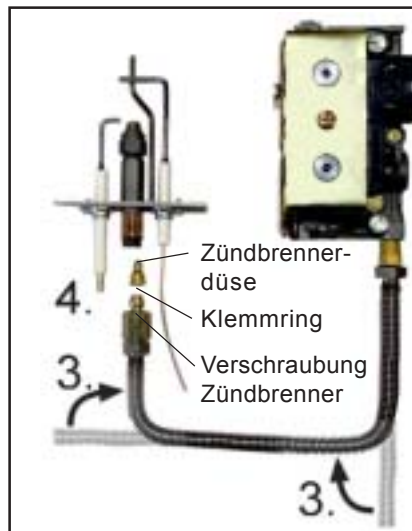
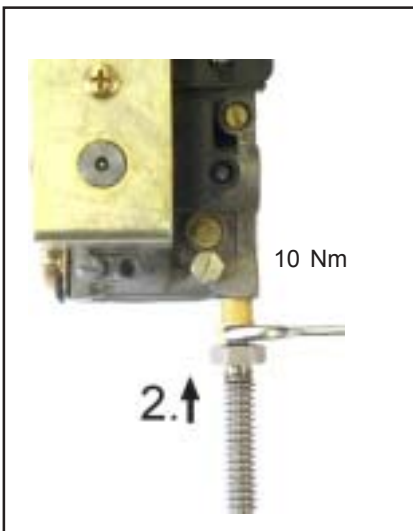

Nach Beendigung der Umrüstung ist eine Gasdichtheitskontrolle durchzuführen!

Notes on replacement of components on Wolf gas boilers



Replacement of single components of the boiler and heating system must be carried out by a qualified fitter only.



Before starting work, the boiler must be turned off and the gas stop cock closed.

When changing one component, such as the gas combination valve, ignition burner or ignition burner nozzle, the ignition gas line must also be replaced.

When changing the gas combination valve, it must be set to the correct nozzle pressure, in accordance with the installation instructions for the boiler (section entitled Gas combination valve / Commissioning).

Changing the ignition burner nozzle:

When changing the ignition burner nozzle, the correct nozzle must be fitted in accordance with the type of gas:

Natural gas:	Nozzle with identification no. 4
Liquefied gas:	Nozzle with identification no. 225

Replacing the ignition gas line:

Take out the old ignition gas line.

1. Fit the screwed connection to the gas combination valve (hand-screwed).

NG-31E-70:	M10
NG-31E-90/-110:	M11

2. Push the ignition gas line into the gas combination valve until the stop position is reached and pull screwed connection tight (drive torque 7-10 Nm).
3. Bend the flexible ignition gas line (copy shape of previous ignition gas line).
4. Push the screwed connection of the ignition burner and the clamping ring onto the ignition gas line.
5. Push the ignition gas line into the ignition burner until the stop position is reached and pull screwed connection tight (drive torque 7-10 Nm). Counterhold hexagon nut on flexible ignition gas line to avoid torsion of the conduit.

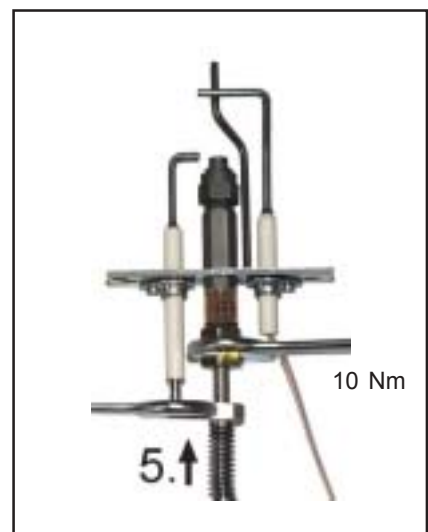
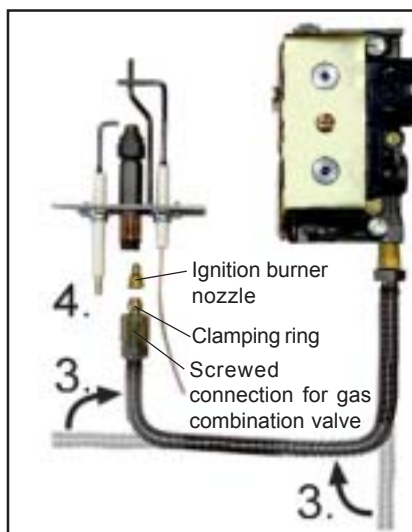
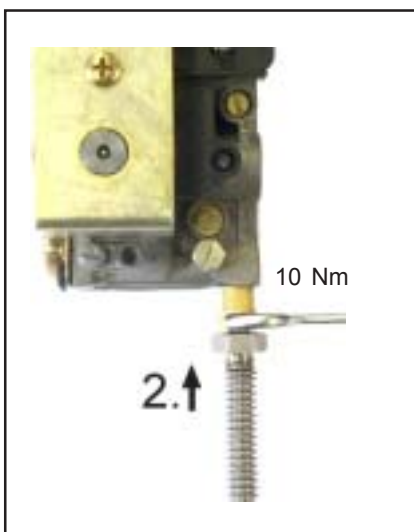
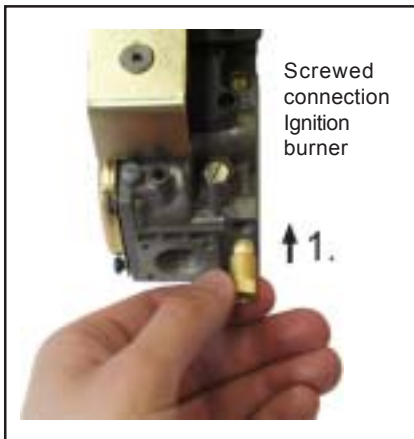

After completing the replacement, a gas leakage test must be carried out!

F

Conseils relatifs au remplacement de pièces sur les chaudières Wolf



Le remplacement de pièces composant la chaudière et l'installation de chauffage ne doit être effectué que par un installateur qualifié.



La chaudière doit être mise hors service avant de commencer les travaux sur celle-ci. Fermer le robinet-vanne d'arrivée de gaz !

Lors du remplacement de composants comme par exemple de la vanne combinée, du brûleur d'allumage ou du gicleur de brûleur d'allumage, remplacer également la conduite de gaz d'allumage correspondante.

Suite au remplacement de la vanne combinée, il est nécessaire de la régler à la pression de gicleur correcte ; cette opération est décrite dans les instructions de montage de la chaudière (Paragraphe vanne combinée / mise en service).

Remplacement des gicleurs du brûleur d'allumage:

Lors du remplacement des gicleurs, il est nécessaire de remonter des gicleurs corrects, adaptés au type de gaz:

Gaz naturel:	Gicleur référencé 4
Gaz liquide:	Gicleur référencé 225

Remplacement de la conduite de gaz d'allumage:

Démonter l'ancienne conduite de gaz d'allumage.

1. Serrer la visserie à la vanne combinée de gaz (vissée à la main).

NG-31E-70:	M10
NG-31E-90/-110:	M11

2. Enfiler la conduite de gaz d'allumage à fond à la vanne combinée et serrer la visserie (couple moment de force 7-10 Nm).
3. Plier la conduite de gaz d'allumage flexible (copier la forme de l'ancienne conduite).
4. Poser la visserie du brûleur d'allumage et l'anneau de serrage sur la conduite de gaz d'allumage.
5. Enfiler la conduite de gaz d'allumage à fond au brûleur d'allumage et serrer la visserie (couple moment de force 7-10 Nm). Supporter la conduite flexible à la vis hexagonale pour éviter la torsion.

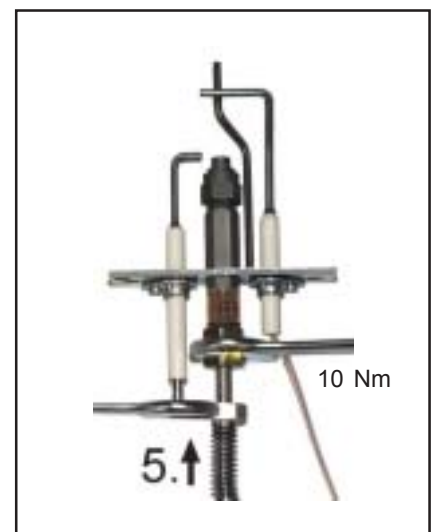
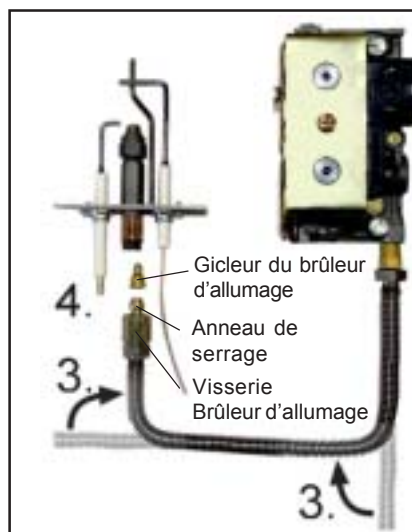
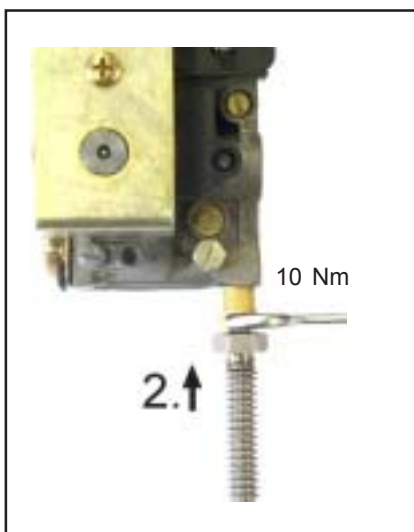

Effectuer absolument un contrôle d'étanchéité au gaz après avoir effectué les travaux !



Avvertenze per la sostituzione dei singoli componenti delle caldaie a gas Wolf



La sostituzione dei singoli componenti della caldaia e dell'impianto di riscaldamento deve essere eseguita da un installatore specializzato.



Prima di iniziare i lavori sulla caldaia, spegnere la stessa e chiudere il rubinetto del gas.

Nel caso in cui venisse sostituito anche uno dei componenti quali valvola del gas, bruciatore d'accensione oppure ugello del bruciatore, deve sempre essere sostituito anche il tubo del gas d'accensione.

Se viene sostituita la valvola del gas, la stessa valvola deve essere regolata alla pressione degli ugelli corretta in base alle istruzioni di montaggio (paragrafo valvola del gas/messa in servizio).

Sostituzione dell'ugello del bruciatore d'accensione:

Se viene sostituito l'ugello del bruciatore d'accensione, deve essere inserito l'ugello adatto al tipo di gas utilizzato come riportato sotto:

Gas metano:	ugello con codice 4
Gas liquido:	ugello con codice 225

Sostituzione del tubo del gas d'accensione:

Smontare il tubo del gas d'accensione

1. Avvitare il raccordo a vite nella valvola del gas manualmente.

NG-31E-70:	M10
NG-31E-90/-110:	M11

2. Inserire il tubo del gas d'accensione fino all'arresto ed avvitare il raccordo a vite (momento torcente 7-10Nm).
3. Piegarlo il tubo flessibile del gas d'accensione (utilizzare il tubo del gas d'accensione smontato come campione).
4. Spingere il raccordo a vite del bruciatore d'accensione e l'anello di fissaggio sul tubo del gas d'accensione.
5. Inserire il tubo del gas d'accensione fino all'arresto nel bruciatore d'accensione ed avvitare il raccordo a vite (momento torcente 7-10Nm). Durante l'operazione tenere con una chiave fissa il raccordo esagonale per evitare un'eventuale torsione del tubo.

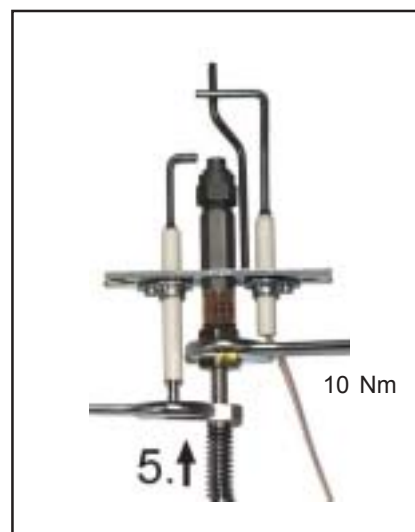
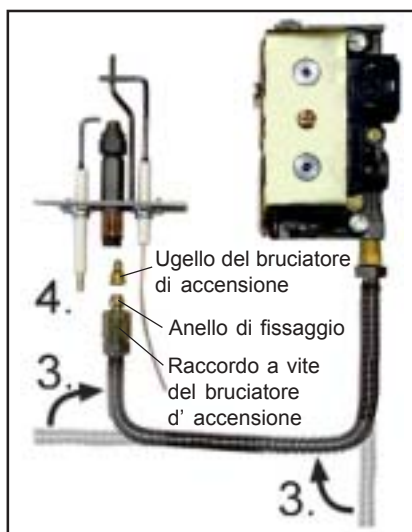
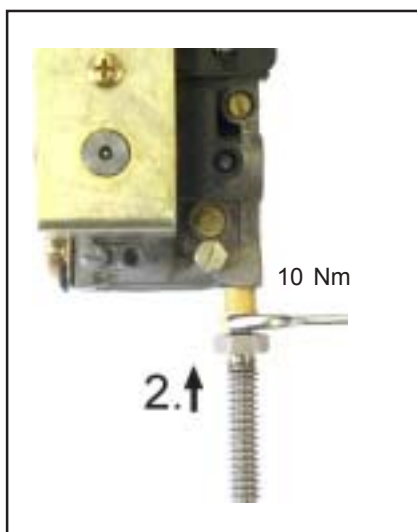

Al termine della trasformazione controllare la tenuta del gas!

Указания по замене отдельных компонентов на газовых отопительных котлах Wolf



К замене любых компонентов на отопительных котлах допускаются только квалифицированные специалисты уполномоченных сервисных центров.



Перед проведением любых работ, необходимо выключить котел и перекрыть подачу газа.

При замене таких компонентов газового котла как комбинированный газовый клапан, запальная горелка или сопло запальной горелки, необходимо также выполнить замену запального газопровода.

При замене комбинированного газового клапана (см. инструкцию по монтажу газового котла, раздел *Комбинированный газовый клапан*) необходимо отрегулировать давление газа на соплах.

Замена сопла запальной горелки:

При замене сопла запальной горелки, необходимо выбрать и установить сопло в соответствии с типом газа:

	NG-31E	NG-1P
природный газ:	сопло с маркировкой 4	сопло с маркировкой 5
сжиженный газ:	сопло с маркировкой 225	сопло с маркировкой 25

Замена газопровода запальной горелки:

Демонтировать старый газопровод.

1. Выбрать соответствующее переходное соединение газового клапана и ввинтить в клапан (вручную).

NG-31E-70:	M10
NG-31E-90/-110; NG-1P:	M11

2. Ввести газопровод до упора в газовый комбинированный клапан и затянуть резьбу (момент вращения 10 нанометров).
3. Изогнуть гибкий газопровод (используя старый в качестве образца).
4. Резьбовое соединение запальной горелки и зажим (зажимное кольцо) надеть на газопровод.
5. Ввести газопровод до упора в запальную горелку и затянуть резьбу (момент вращения 10 нанометров). При этом придерживать шестигранник гибкого газопровода, чтобы предотвратить его перекручивание.

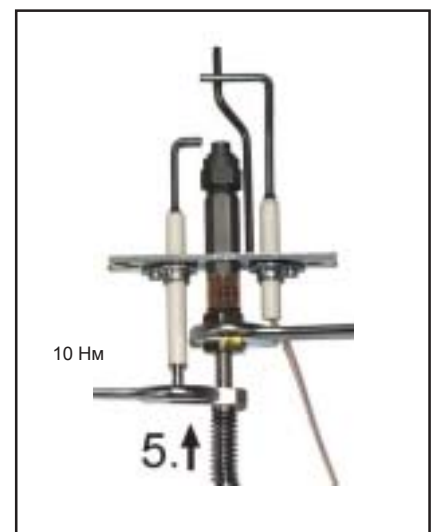
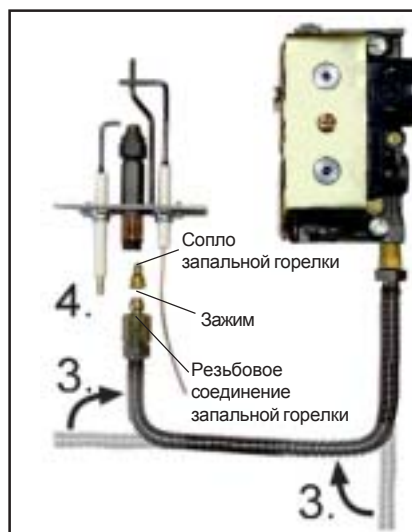
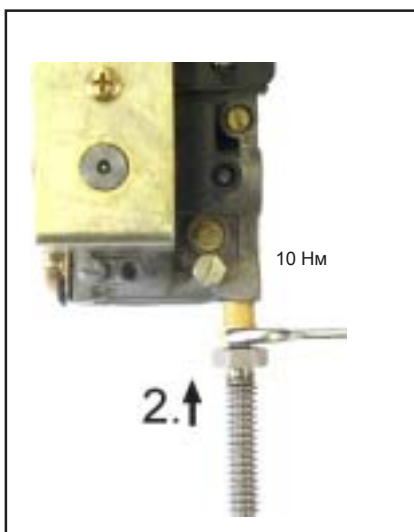

По окончании работ провести контроль герметичности газопровода!

