

AQCL / AQCH 25 ÷ 80



English

Français



25
÷
76 kW



27
÷
84 kW



Air cooled chillers and heat pumps with centrifugal fans

Refroidisseurs de liquide et pompes à chaleur avec ventilateurs centrifuges

IOM AQC-N.3GBF

Date : **October 2005 / Octobre 2005**

Supersedes / Annule et remplace : **IOM AQC-N.2GBF**



INSTALLATION INSTRUCTION

NOTICE D'INSTALLATION

INSTALLATIONSHANDBUCH

ISTRUZIONI INSTALLAZIONE

INSTRUCCIONES DE INSTALACIÓN

English

Français

Deutsch

Italiano

Español

CONTENTS

GENERAL RECOMMENDATIONS	3
SAFETY DIRECTIONS	3
WARNING	3
PRESENTATION	4
WARRANTY	4
EQUIPMENT SAFETY DATA	5
INSPECTION AND STORAGE	6
CONTENTS OF PACKAGE	6
PRODUCT OFFER AND VARIANTS	6
DESCRIPTION	7
CABINET AND FRAME	7
COMPRESSORS	7
EVAPORATORS	7
CONDENSER BATTERIES	7
CONDENSER FANS	7
FAN CONTROL/COMMANDE DES VENTILATEURS	7
REFRIGERATING CIRCUIT	7
POWER SUPPLY AND CONTROL BOX	7
TECHNICAL SPECIFICATIONS	8
REFRIGERANT CHARGE	8
ELECTRIC SPECIFICATIONS	8
AERAILIC TECHNICAL SPECIFICATIONS	9
FLOW RATE / EXTERNAL STATIC PRESSURE	9
DIMENSIONS	10
HANDLING	10
WEIGHT	10
DUCT OUTLET DIMENSIONS	11
STANDARD BLOWING	11
REAR BLOWING	11
VERTICAL BLOWING	11
INSTALLATION	12
CLEARANCE	12
LOCATING THE UNIT	12
DE-ICING WATER DRAINAGE (AQCH MODELS ONLY)	13
ANTI-VIBRATION SPRING-MOUNTED PADS OR RUBBERS PAD INSTALLATION (IN OPTION)	13
HYDRAULIC CONNECTIONS	13
HYDRAULIC CIRCUIT DIAGRAM	14
FLOW SWITCH FOR 25-30-35 MODEL	14
WIRING DIAGRAM AND LEGEND	15
WIRING DIAGRAM	15
LEGEND	15
POWER SUPPLY	15
WIRING DIAGRAM KEY DESCRIPTIONS	16
COOLING	16
FAN MOTOR AND THEIR EQUIPMENT	16
WATER CIRCUIT	16
CONTROL AND REGULATION	17
NOT PROVIDED	17
RANGE AND SETTINGS OF THERMAL PROTECTION / NOMINAL INTENSITY OF THE CONTACTORS (CLASSE AC3)	17
PRESSOSTATS SETTING	17
MISCELLANEOUS	17
ELECTRICAL CONNECTIONS	18
REMOTE ON/OFF SWITCH	19
ALL SEASONS KIT (FREQUENCY DRIVE)	20
REGULATION	21
ILTC CONTROL	21
GENERAL INFORMATION	21
DIP SWITCH	22
FUNCTION OF DSW1 DIP SWITCHES	22
FUNCTION OF DSW2 DIP SWITCHES	22
ELECTRONIC BOARD CONTROLS	22
KEYBOARD	22
DISPLAY	23
ILTC USER MENU INDEX	23
ALAR AND LOG MENU	24
SENS MENU - SENSORS READOUT	25
PARAMETERS LEVEL	25
PARAM MENU - USER LEVEL *	25
SERVICE LEVEL PARAMETERS	25
COMMISSIONING	26
PRE-START CHECK LIST	26
ELECTRICAL CHECK	26
HYDRAULIC CHECKS	26
VISUAL CHECK	26
DUCTING	26
OPERATING CHECK LIST	27
GENERAL	27
PHASE ROTATION PROTECTION	27
ELECTRICAL	27
SET POINTS	27
OPERATING VOLTAGE	27
CONTROL	27
FAN & DRIVE	27
COMPRESSOR AND REFRIGERATION SYSTEM	27
HYDRAULIC CIRCUIT	28
FINAL CHECK	29
FINAL TASKS	29
IN-WARRANTY RETURN MATERIAL PROCEDURE	29
SERVICE AND SPARE PARTS ORDER	29
MAINTENANCE	30
REGULAR MAINTENANCE	30
REMOVAL OF PANELS	30
FAN DRIVE SYSTEM	30
COILS	30
ELECTRICAL	30
REFRIGERATION	30
SERVICING CHECKLIST	31
TROUBLE SHOOTING	32



POWER SUPPLY MUST BE SWITCHED OFF BEFORE STARTING TO WORK IN THE ELECTRIC CONTROL BOX

GENERAL RECOMMENDATIONS

Please read the following safety precautions very carefully before installing the unit.

SAFETY DIRECTIONS

Follow the safety rules in forces when you are working on your appliance.

The installation, commissioning and maintenance of these units should be performed by qualified personnel having a good knowledge of standards and local regulations, as well as experience of this type of equipment.

The unit should be handled using lifting and handling equipment appropriate to the unit's size and weight.

Any wiring produced on site must comply with the corresponding national electrical regulations.

Make sure that the power supply and its frequency are adapted to the required electric current of operation, taking into account specific conditions of the location and the current required for any other appliance connected with the same circuit.

The unit must be EARTHED to avoid any risks caused by insulation defects.

It is forbidden to start any work on the electrical components if water or high humidity is present on the installation site.

WARNING

Cutoff power supply before starting to work on the appliance.

When making the hydraulic connections, ensure that no impurities are introduced into the pipe work.

The manufacturer declines any responsibility and the warranty becomes void if these instructions are not respected.

If you meet a problem, please call the Technical Department of your area.

If possible, assemble the compulsory or optional accessories before placing the appliance on its final location. (see instructions provided with each accessory).

In order to become fully familiar with the appliance, we suggest to read also our Technical Instructions.

-The information contained in these Instructions are subject to modification without advance notice.

PRESENTATION

All the models in the AQCL / AQCH liquid coolers range are produced to state-of-the-art design and manufacturing standards. In this way, they offer guarantees of high performance and reliability as well as the capability of adapting to all types of air conditioning installations operating with both chilled water and glycol solutions (and with hot water for the Heat pump units). The unit is not suitable for any use other than those specified in the present manual.

Improper usage of the unit or a use for purposes other than those originally intended, without the prior approval by the manufacturer or its agents, could result in the unit functioning outside its safe operating limits and could present risks to both personnel and property.

The present manual contains all the information required for proper installation and commissioning of the unit as well as user and maintenance instructions. We strongly advise you to read this manual carefully before commissioning and using the unit.

With the exception of the operations described in this manual only qualified personnel, trained in the latest refrigeration engineering practices, should perform installation, commissioning and maintenance operations.

The manufacturer declines all liability for personal injuries and material damage resulting from incorrect installation, commissioning or use and/or insufficient maintenance. It also declines all liability for personal injuries and material damage resulting from non-compliance with the procedures and instructions contained in the present manual.

WARRANTY

The appliances are delivered fully assembled, factory tested and ready to operate.

Any modification to the units without the manufacturer's prior approval, shall automatically render the warranty null and void.

The following conditions must be respected in order to maintain the validity of the warranty:

- Commissioning shall be performed by specialised technicians from technical services approved by the manufacturer.
- Maintenance shall be performed by technicians trained for this purpose.
- Only Original Equipment spare parts shall be used.
- All the operations listed in the present manual shall be performed within the prescribed timescales.



An appropriate water filter must be installed on the external cold water supply circuit. The warranty shall be null and void if such a filter is not installed.

THE WARRANTY SHALL BE NULL AND VOID IN THE EVENT OF NON-COMPLIANCE WITH ANY OF THE ABOVE CONDITIONS.

EQUIPMENT SAFETY DATA

Safety Data	R407C
Toxicity	Low
In contact with skin	Liquid splashes or sprays may cause freeze burns. Unlikely to be hazardous by skin absorption. However, R407C may be slightly irritant and, if liquid, it has a strong degreasing effect. Flush contaminated skin areas with running water. If it comes into contact with wet fabrics, the liquid refrigerant will cause them to freeze and adhere to the skin. Carefully remove the contaminated clothing since it might adhere to the skin and cause freeze burns. Apply to a doctor if the affected skin areas should be reddened or irritated.
In contact with eyes	Vapours have no effect. Liquid splashes or sprays may cause freeze burns. In these cases rinse your eyes with running water or with a solution for eye lavages for at least 10 minutes. Immediately apply to a doctor.
Ingestion	Very unlikely to occur. If this should be the case, it may cause freeze burns. Never induce vomiting. Keep the patient awake. Make it rinse its mouth with running water and make it drink about 1/4 of a litre. Immediately apply to a doctor.
Inhalation	R407C: High concentration levels of its vapours in the air can produce an anaesthetic effect, including the loss of consciousness. Particularly severe exposures may cause heart arrhythmic and sometimes prove to be also fatal. At high concentrations there is a danger of asphyxia due to a reduced oxygen content in the atmosphere. In these cases take the patient to the open air, in a cool place and keep it at rest. Administer oxygen, if required. Apply artificial respiration if breathing has ceased or if it has become irregular. In case of heart failure immediately apply cardiac massage. Immediately apply to a doctor.
Further Medical Advice	A symptomatic and supportive therapy is generally suitable. A heart sensitisation has been observed in some cases, as a result of exposures to particularly high concentrations. In the presence of catecholamines (such as for example adrenaline) in the blood flow, it has increased the irregularity of the cardiac rhythm and then caused the heart failure.
Long-term exposure	R407C: A lifetime study which has been conducted on the effects inhalation may have on rats at 50,000 ppm has shown the onset of benign tumours of the testicle. These remarks suggest that there is no danger for human beings if they are exposed to concentrations below the occupational limits or equal to them.
Occupational exposure limits	R407C: Recommended limits: 1,000 ppm v/v 8 hours TWA.
Stability	R407C: Not specified.
Conditions to avoid	Use in the presence of exposed flames, red heat surfaces and high humidity levels.
Hazardous reactions	Possibility of violent reactions with sodium, potassium, barium and other alkaline substances. Incompatible materials: magnesium and all the alloys containing over 2% of magnesium.
Hazardous decomposition products	R407 C: Halogen acids deriving from thermal decomposition and hydrolysis.
General precautions	Avoid the inhalation of high concentrations of vapours. The concentration in the atmosphere shall be kept at the minimum value and anyway below the occupational limits. Since vapours are heavier than air and they tend to stagnate and to build up in closed areas, any opening for ventilation shall be made at the lowest level.
Breathing protection	In case of doubt about the actual concentration, wear breathing apparatus. It should be self-contained and approved by the bodies for safety protection.
Storage Preservation	Refrigerant containers shall be stored in a cool place, away from fire risk, direct sunlight and all heat sources, such as radiators. The maximum temperature shall never exceed 45°C in the storage place.
Protection clothes	Wear boots, safety gloves and glasses or masks for facial protection.
Behaviour in case of leaks or escapes	Never forget to wear protection clothes and breathing apparatus. Isolate the source of the leakage, provided that this operation may be performed in safety conditions. Any small quantity of refrigerant which may have escaped in its liquid state may evaporate provided that the room is well ventilated. In case of a large leakage, ventilate the room immediately. Stop the leakage with sand, earth or any suitable absorbing material. Prevent the liquid refrigerant from flowing into drains, sewers, foundations or absorbing wells since its vapours may create an asphyxiating atmosphere.
Disposal	The best procedure involves recovery and recycle. If this is not possible, the refrigerant shall be given to a plant which is well equipped to destroy and neutralise any acid and toxic by-product which may derive from its disposal.
Combustibility features	R407C: Non flammable in the atmosphere.
Containers	If they are exposed to the fire, they shall be constantly cooled down by water sprays. Containers may explode if they are overheated.
Behaviour in case of fire	In case of fire wear protection clothes and self-contained breathing apparatus.

INSPECTION AND STORAGE

At the time of receiving the equipment carefully cross check all the elements against the shipping documents in order to ensure that all the crates and boxes have been received. Inspect all the units for any visible or hidden damage.

In the event of shipping damage, write precise details of the damage on the shipper's delivery note and send immediately a registered letter to the shipper within 48 hours, clearly stating the damage caused. Forward a copy of this letter to the manufacturer or their representative.

Never store or transport the unit upside down. It must be stored indoors, completely protected from rain, snow etc. The unit must not be damaged by changes in the weather (high and low temperatures). Excessively high temperatures (above 60 °C) can harm certain plastic materials and cause permanent damage. Moreover, the performance of certain electrical or electronic components can be impaired.

CONTENTS OF PACKAGE

- 1 AQCL or AQCH unit
- 1 Bag with reference materiel.
 - 1 installation and maintenance manual
 - 1 regulation instruction manual

PRODUCT OFFER AND VARIANTS

Several variants of these appliances are available:

- Standard or Heat pump models
- Ventilation
 - ◆ basse static pressure or high static pressure
 - ◆ standard blowing
 - ◆ vertical blowing
 - ◆ front/rear blowing
- Regulation
 - ◆ fixed ventilation (fan) speed
 - ◆ Ventilation (fan) speed variation system
- Hydraulic
 - ◆ Basic version (without pump)
 - ◆ Pack version (with pump)
 - ◆ Dual pump option for models 40-50-60-70-80

DESCRIPTION

The AQCL / AQCH units are monobloc, single circuit liquid coolers for air conditioning applications, operating with water or water/glycol solution.

After the units are assembled, the refrigerating and electrical circuits are tested at the factory in order to guarantee correct operation.

The are filled with an operational refrigerant fluid charge and are subjected to pressure tightness tests.

The AQCL Cooling only models can produce chilled water at temperatures varying between +18 °C to +5 °C or chilled water/glycol solution at temperatures varying between +5 °C to -5 °C.

The AQCH Heat pump models can produce hot water at temperatures varying between +25 °C and +50 °C.

CABINET AND FRAME

The units' base and frame are made of high thickness galvanised steel elements assembled with screws.

All the cabinet panels can be easily removed to provide access to the various internal components. The galvanised steel panels are coated with oven-baked white paint (RAL9001).

COMPRESSORS

The units are equipped with two sealed Scroll compressors, mounted in tandem.

The compressors are mounted on vibration absorbing rubber pads.

The compressor motors are cooled by a refrigerating gas and equipped with an internal heat overload thermistor. The overload protection automatically resets itself after about 8 seconds.

EVAPORATORS

The evaporators are of the brazed stainless steel plate heat exchanger type with thermal insulation.

Their service pressure shall be 10 bar (water side) and 30 bar (refrigerant side).

The evaporator is protected against freezing by an electric resistance, a differential pressure pressostat (for models 25 to 35) and a flow controller (for models 40 to 80).

CONDENSER BATTERIES

The condenser batteries are made of weld-free copper pipes that are arranged in staggered rows and crimped in aluminium fins. The batteries' service pressure is 28 bar.

CONDENSER FANS

The condenser fans are of the centrifugal type with dual turbines and are driven by a pulley system. They allow aerodynamic adjustments to be made during installation.

FAN CONTROL/COMMANDE DES VENTILATEURS

The units can be equipped with a ventilation (fan) speed regulator operating in relation to condensing pressure. This enables system operation at outdoor temperatures as low as -10 °C.

REFRIGERATING CIRCUIT

Each unit has a single refrigerating circuit equipped with an external service valve (for raising the refrigerant pressure and for filling the refrigerant fluid charge), with a liquid inspection porthole integrating a humidity indicator, a dehumidification filter and a thermostatic pressure relief valve.

A high pressure pressostat and high and low pressure transducers are also provided on the refrigerating circuit.

POWER SUPPLY AND CONTROL BOX



All the control and motor starting equipment necessary for efficient unit operation is wired and tested at the factory.

A service hatch, offering easy access, protects the power supply and control components.

TECHNICAL SPECIFICATIONS

REFRIGERANT CHARGE



Packaged model	25	30	35	40	50	60	70	80
Refrigerant charge 	6500 g	7050 g	8500 g	10000 g	13760 g	16000 g	16310 g	16310 g
 	6250 g	7360 g	10510 g	10500 g	12500 g	12950 g	23000 g	23000 g

Therefore, both the installation itself and its environment are critical parameters for its proper operation.

ELECTRIC SPECIFICATIONS

Type of appliance		25		30		35		40	
		PE	GE	PE	GE	PE	GE	PE	GE
Power supply 3N ~ 400 V - 50 Hz		•		•		•		•	
Cooling + Fan (or heatpump heating)									
Maximum Current	A	25	27	27	29	31	33	44	47
Fuse Rating A M	A	32		32		40		50	63
Fuse rating ASE / VDE*	A	35		35		40		50	63
Total Starting Current	A	80	82	82	92	122	124	140	142
Power supply cable*	mm ²	5G6		5G6		5G10		5G10	
Connections									
Maximum Current	A	3.7		4.7		6.3		6.3	
Cable section*	mm ²	4G1.5		4G1.5		4G1.5		4G1.5	

Type of appliance		50		60		70		80	
		PE	GE	PE	GE	PE	GE	PE	GE
Power supply 3N ~ 400 V - 50 Hz		•		•		•		•	
Cooling + Fan (or heatpump heating)									
Maximum Current	A	47	51	53	56	68.8	71.8	71	74
Fuse Rating A M	A	50	63	63		80		80	
Fuse rating ASE / VDE*	A	50	63	63		80		80	
Total Starting Current	A	186	188	232	236	230	233	233	236
Power supply cable*	mm ²	5G25		5G25		5G35		5G35	
Connections									
Maximum Current	A	5.2		6.4		6.4		6.4	
Cable section*	mm ²	4G1.5		4G1.5		4G1.5		4G1.5	

IMPORTANT

* These values are given for guidance. They must be checked and adjusted according to prevailing standards. They depend on the system installed and the cables used.

AERAUIC TECHNICAL SPECIFICATIONS

Models		25	30	35	40	
Number of fans		2	2	2	2	
Typ		Centrifugal				
Drive typ (belt)		Belt with variable pulley				
Power supply		3N ~400 V - 50 Hz				
Motor						
Rating	PE	kW	3	3	3	4
	GE	kW	4	4	4	5
Speed	tr/min		1420	1420	1420	1420

Models		50	60	70	80	
Number of fans		2	2	2	2	
Typ		Centrifugal				
Drive typ (belt)		Belt with variable pulley				
Power supply		3N ~400 V - 50 Hz				
Motor						
Rating	PE	kW	5.5	5.5	7.5	7.5
	GE	kW	7.5	7.5	11	11
Speed	tr/min		1420	1420	1430	1430

FLOW RATE / EXTERNAL STATIC PRESSURE

	25	30	35	40
m ³ /h	13500	14000	14000	15000
PE Pa max	130	130	130	130
GE Pa max	200	200	200	200

	50	60	70	80
m ³ /h	19500	20000	26000	27000
PE Pa max	130	130	200	200
GE Pa max	200	200	400	400

You can adjust flow rate and available static pressure with a variable pulley of the outdoor unit (SEE APPENDIX).

DIMENSIONS

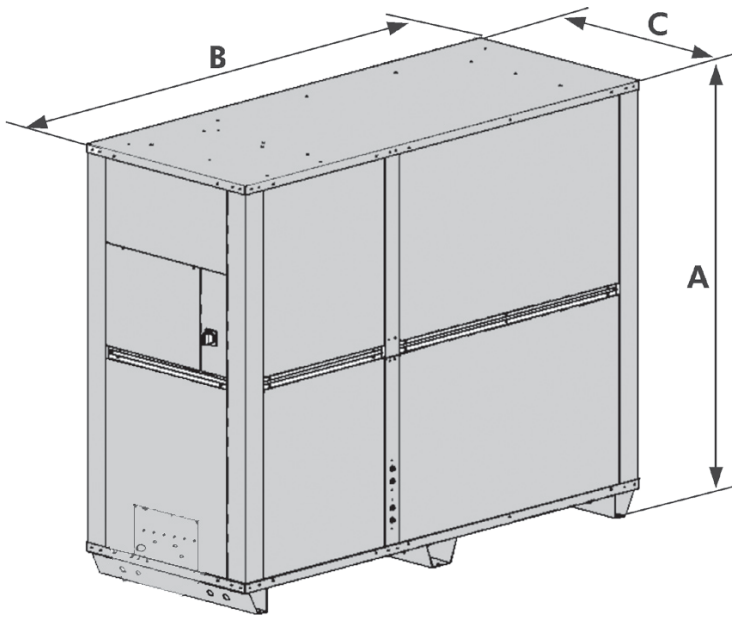

25 - 30 - 35

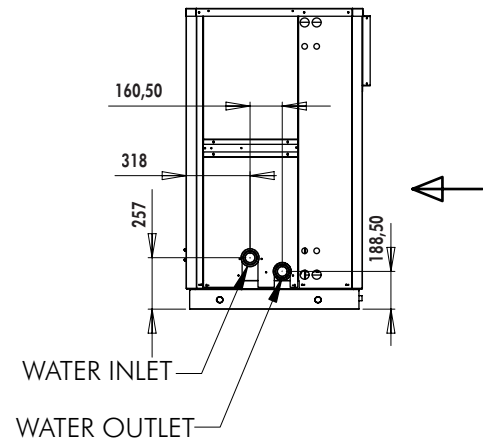

40 - 50 - 60 - 70 - 80

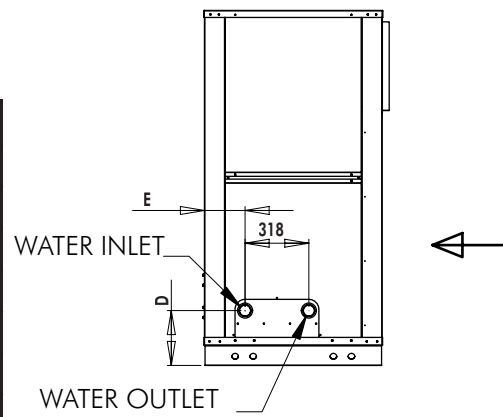

	A	B	C	E	F
25	1505	1750	890	274	202.5
30	1505	1750	890	274	202.5
35	1505	1750	890	274	202.5
40	1773	2206	890	274	202.5
50	1773	2206	890	274	202.5
60	1773	2206	890	274	202.5
70	2313	2464	1100	344	306
80	2313	2464	1100	344	306

HANDLING

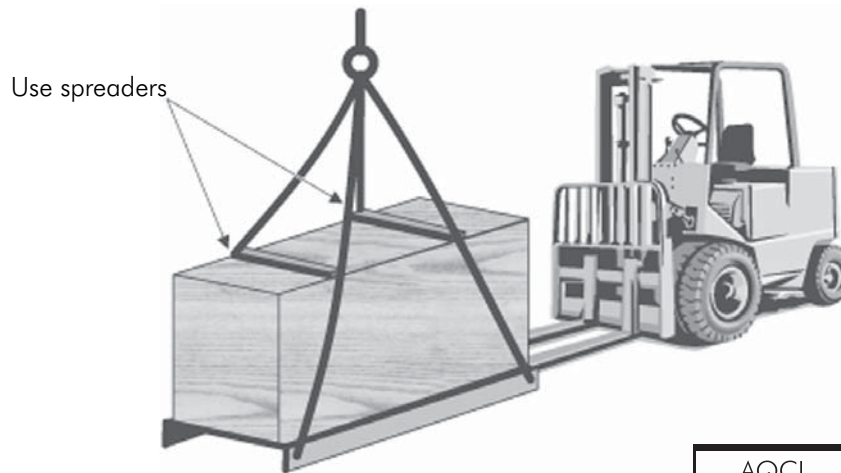

WEIGHT

NET WEIGHT

COOLING ONLY AND HEATPUMP

WITH PUMP

WITH LARGE EQUIPMENT

	AQCL	AQCH
25	387 kg	395 kg
30	405 kg	420 kg
35	415 kg	435 kg
40	575 kg	580 kg
50	630 kg	650 kg
60	660 kg	670 kg
70	865 kg	875 kg
80	920 kg	930 kg

DUCT OUTLET DIMENSIONS STANDARD BLOWING

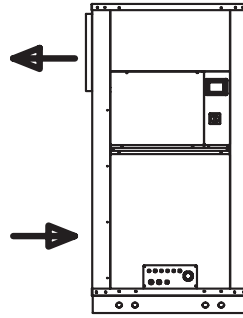
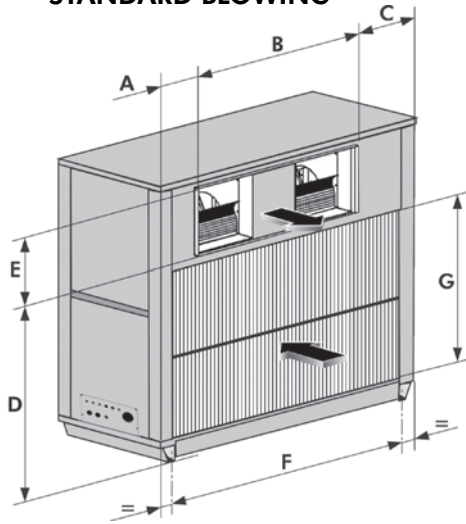

	A	B	C	D	E	F	G
25	150	1350	250	1115	348	1500	950
30	150	1350	250	1115	348	1500	950
35	150	1350	250	1115	348	1500	950
40	285	1400	530	1275	450	2110	1085
50	285	1400	530	1275	450	2110	1085
60	285	1400	530	1275	450	2110	1085
70	314	1600	544	1715	500	2413	1500
80	314	1600	544	1715	500	2413	1500

REAR BLOWING

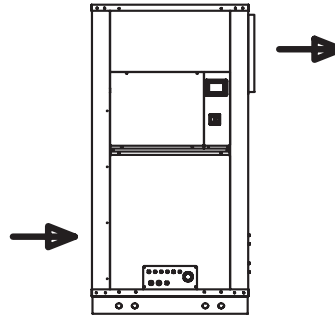
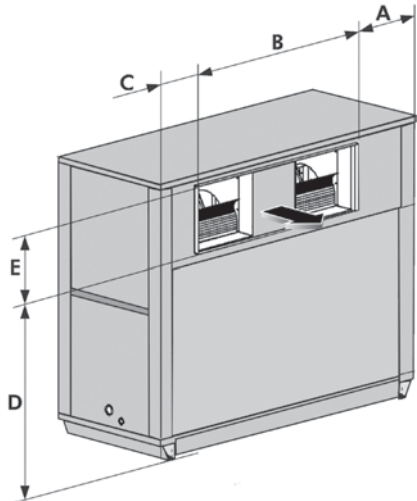

	A	B	C	D	E
25	250	1350	150	1115	348
30	250	1350	150	1115	348
35	250	1350	150	1115	348
40	530	1400	285	1275	450
50	530	1400	285	1275	450
60	530	1400	285	1275	450
70	544	1600	314	1715	500
80	544	1600	314	1715	500

VERTICAL BLOWING

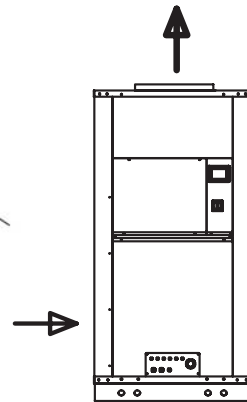
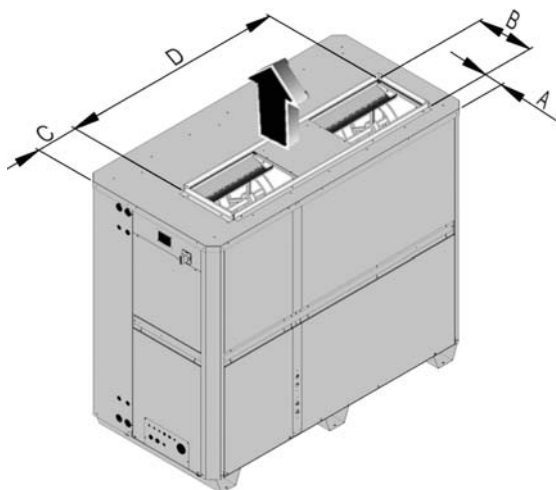

	A	B	C	D
25	63	443	188	1488
30	63	443	188	1488
35	63	443	188	1488
40	215	445	595	1490
50	215	445	595	1490
60	215	445	595	1490
70	150	500	544	1600
80	150	500	544	1600

INSTALLATION

The unit is not designed to withstand weights or stresses from adjacent equipment, pipe work or constructions. Any foreign weight or stress on the unit structure could lead to a malfunction or a collapse with dangerous consequences for personnel and property. In such an event, the warranty shall be null and void.

CLEARANCE

Minimum clearance to be provided for maintenance access.



Dimensions depend on the factory configuration.

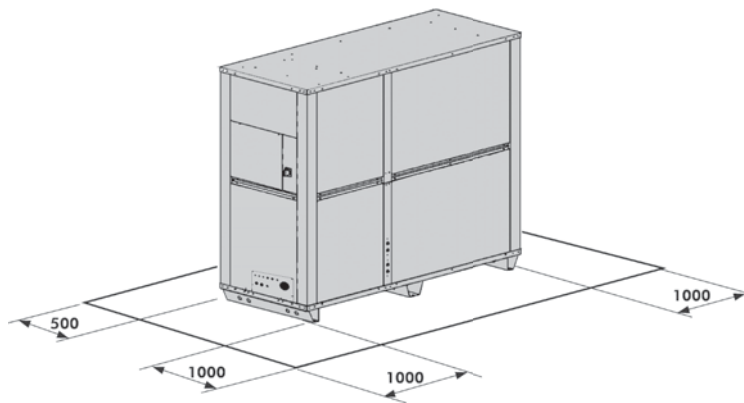

LOCATING THE UNIT



The unit base shall be arranged as indicated in the manual. There could be a risk of personal injury or damage to property in the event of the unit being incorrectly supported.

The unit must be installed on a firm level foundation, of adequate strength to support its full operating weight.

1. It must be high enough to permit good drainage of defrost water with syphon
2. Keep duct connections to a minimum to reduce duct losses.
3. When locating unit give consideration to, and locate unit as remote as possible minimise noise, as heat pump loads are greatest at night time.
4. **The unit must be pitched slightly towards condensate drain outlet to provide positive drainage of condensates.**
5. All electrical and ductwork connections to the unit must be made via flexible connections to prevent transmission of vibration.
6. In addition to the service clearances noted on the dimension sheet it is essential that provision is made for adequate and safe service access.

DE-ICING WATER DRAINAGE (AQCH MODELS ONLY)

When the AQCH unit operates in Heat pump mode, water drains from below during regular de-icing cycles.

The casing of AQCL-AQCH is made to retrain de-icing water and propose 2 evacuations outlet. The AQCH units must be installed in areas where the de-icing water will not present any risks of damage.

25/30/35/70/80

- These models have a sealed base enabling the condensates to be collected.
- Raise the unit to install the siphons on the condensate drainage pipes (left or right).
- Drainage orifice: Ø1"

40/50/60

- These models have a condensate drainage tray supplied with the unit.
- Remove the condensate tray and place it behind the unit.
- Raise the unit to install the siphons on the condensate drainage pipes (left or right).
- Drainage orifice: Ø1"

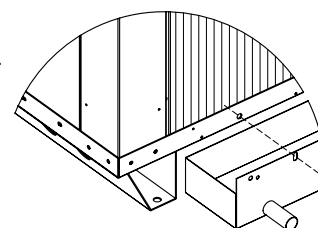

ANTI-VIBRATION SPRING-MOUNTED PADS OR RUBBERS PAD INSTALLATION (IN OPTION)

Prepare the ground surface area. It must be flat and level. Raise the unit and insert the pads in accordance with the following instructions.

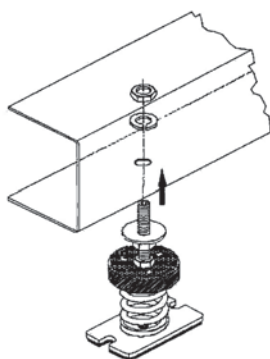

ANTI-VIBRATION
SPRING-MOUNTED PADS

- Respect the mouting instruction
- Assemble the headless screw.
- Insert the screw in the threaded hole situated on the top of the anti-vibration pad. Position the pad under the unit's base and insert the headless screw through the base hole.
- Lock the position with the washer and the nut. After installation, check the correct operation of the pads.

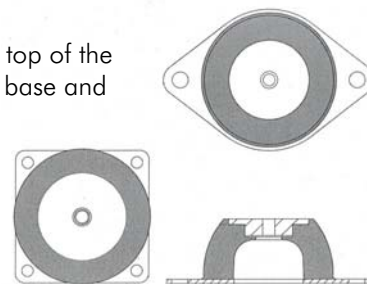

ANTI-VIBRATION RUBBERS
PADS

HYDRAULIC CONNECTIONS



The external hydraulic circuit must provide constant water circulation in the evaporator for all operating settings and conditions.

The size of the expansion tank must be sufficient to receive a 2% increase in the system's total fluid volume (evaporator, pipe links, user circuits and tank, if supplied). It is not necessary to insulate the expansion tank, as water does not circulate through it under normal operating conditions.

The external water system must comprise the following elements:

- A circulation pump supplying sufficient water flow and available pressure.
- The primary water system shall not contain less than 2.5 litres of water per kW of cooling capacity. If the total volume in the primary system pipe work and in the evaporator is insufficient, a heat-insulated tank shall be installed.
- This will avoid continual compressor start-ups.
- A diaphragm type expansion tank equipped with a safety valve with a set discharge point. The valve shall be visible.

HYDRAULIC CIRCUIT WATER VOLUME

SEE APPENDIX

Models 25 to 35 are equipped with a differential pressostat as standard equipment. The pressostat detects water pressures losses across the evaporators and shuts down the unit in the event of an anomaly occurring.

On models 40 to 80, a water flow controller is fitted instead of the differential pressostat.

In addition:

- Install stop cocks on the evaporator water inlet and outlet pipes.
- Install an evaporator by-pass with a stop cock.
- Install air bleed valves at the highest points on the pipe links.
- Install suitable system drainage points (with take-offs, taps, etc.) on the lowest points on the pipe links.
- Insulate all pipe work to prevent heat losses.

TO FILL THE CIRCUIT BEFORE THE STARTING OF THE PUMP



Prior to filling the system, ensure that it contains no foreign bodies (sand, stones, rust or brazing flakes, swarf) or any other material that might damage the evaporators.

The water used to fill the circuit should be treated, as required, to ensure a correct pH value.

When two or three units are connected in parallel, it is recommended that the return circuit connections are reversed (see below) in order to reduce the pressure loss in each unit's circuit.

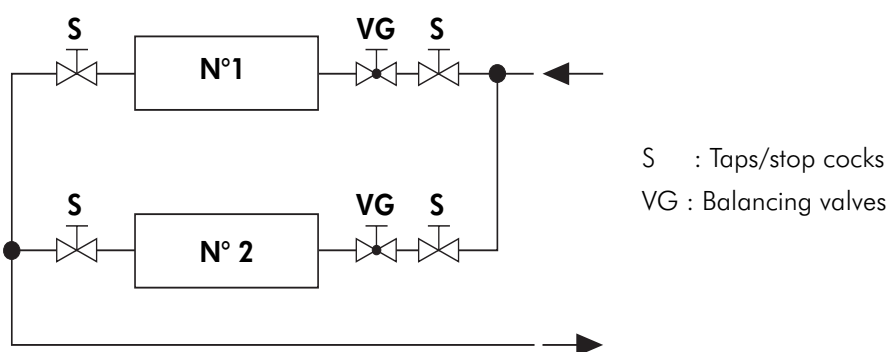

The standard evaporators fitted to AQC units are designed for cooling solutions of water and ethylene glycol, with an anti-corrosion additive, for protection down to temperatures of -8°C (R 407C).

Refer to the Appendix for the quantity of ethylene glycol to be added.

The quantities are defined as a percentage in relation to the theoretical weight of water contained in the circuit.

The inlet and outlet water pipe links must be connected correctly, as indicated on the labels situated close to the pipe unions.

Connect the external water supply pipes to the unit's water inlet and outlet unions.

HYDRAULIC CIRCUIT DIAGRAM

SEE APPENDIX

FLOW SWITCH FOR 25-30-35 MODEL

SEE APPENDIX

WIRING DIAGRAM AND LEGEND

WIRING DIAGRAM

SEE APPENDIX

LEGEND

N 728

SE 3289 models 25/30/35	Control	230V 50Hz +/- 10%	
SE 3288 models 25/30/35	Power Tri	400V+N 50Hz +/- 10%	
SE 3312 models 40/50/60/70/80	Control	230V 50Hz +/- 10%	
SE 3313 models 40/50/60/70/80	Power Tri	400V+N 50Hz +/- 10%	
SE 3372 models 40/50/60/70/80	Control	230V 50Hz +/- 10%	dual pumps
SE 3371 models 40/50/60/70/80	Power Tri	400V+N 50Hz +/- 10%	dual pumps

POWER SUPPLY

This supply is protected upstream by an FFG general supply fuse holder, to be provided by the installer, in accordance with Table 1 – Small equipment or Table 2 – Large Equipment. The fuse holder shall be mounted close to the unit.

The electrical installation and the wiring of this unit shall comply with local electrical installation standards.

- Three phase 400 V~ + Neutral + Ground:
On terminals P-E ; N ; L1 ; L2 ; L3 on Main Terminal Block X1.
- Three phase 400V ~ + Ground: (Models 40 to 80 only: Transformer option obligatory)
On terminals P-E ; L1 ; L2 ; L3 and Ground on Main Terminal Block X1.

TABLE 1: CASE SMALL EQUIPMENT

AQCL AQCH	FFG Fuse aM Type	Full load current (max.) 400V	Starting amperage (max.)
25	32 A	25 A	80 A
30	32 A	27 A	82 A
35	40 A	31 A	122 A
40	50 A	44 A	140 A
50	50 A	46.8 A	186 A
60	63 A	53 A	232 A
70	80 A	68.8 A	230 A
80	80 A	71 A	233 A

TABLE 2: CASE LARGE EQUIPMENT

AQCL AQCH	FFG Fuse aM Type	Full load current (max.) 400V	Starting ampe- rage (max.)
25	32 A	27 A	82 A
30	32 A	29 A	92 A
35	40 A	33 A	124 A
40	63 A	47 A	142 A
50	63 A	51 A	188 A
60	63 A	56 A	236 A
70	80 A	71.8 A	233 A
80	80 A	74 A	236 A

WIRING DIAGRAM KEY DESCRIPTIONS

- FFG : Safety fuses (not provided)
 X1 : Main Terminal Block (mod.40/50/60/70/80)
 QG : Main supply switch
 KA1 : Three phase network control relay (phase sequence and cut-out)
 FF7 : magneto-thermal trip switch

COOLING

- M1/M2 : Refrigerating compressor
 KS1/KS2 : Internal safeties of compressors M1/M2 (mod. 40/50/60/70/80)
 K1/K2 : Compressor power contactor M1/M2
 FT1/FT2 : Thermo-magnetic compressor circuit breaker M1/M2 (mod. 25/30)
 HP1 : High pressure pressostats (automatic reset)
 FPC : Condenser pressure transducer
 FPE : Evaporator pressure transducer
 R1/R2 : Sump heating resistances.
 RV1 : Cycle reversal valve (Heat pump model).

FAN MOTOR AND THEIR EQUIPMENT

- M5 : Air exchanger fan motors
 K5 : Motor power contactor M5
 FM5 : Motor internal safety M5

STANDARD OPTION

- FT5 : Thermo-magnetic motor circuit breaker M5

OPTION ALL SEASONS

- KA2 : Auxiliary heating demand relay (Heat pump models)
 ACS : Three phase frequency converter with RFI filter (SEE INSTALLATION MANUAL)

WATER CIRCUIT

- FDP : Water circuit inlet : outlet differential pressostat (Contact normally open when no voltage present and no pressure present in the circuit)(mod 25/30/35)
 FS : Water flow detector (*FLOW SWITCH*) (mod 40/50/60/70/80)
 RAG : Plate exchanger anti-freezing re-heater (2 IN mod. 40/50/60/70/80)

OPTION PUMP

- M4 : Water pump
 K4 : Pump contactor MP
 FT4 : Thermo-magnetic pump relay MP

OPTION DOUBLE PUMPS

- PUMP CTRL: control box of the water pumps 1 and 2
 X2 : Main Terminal Block of control box
 FT41/42 : Thermo-magnetic pump relay
 K41/42 : Pump contactor
 SP : selector of pump

- H1/H2 : indicator of ON
 H3 : indicator of defect
 MP1/MP2 : Water pump 1/2
 IPSO1/2 : pum internal safety

CONTROL AND REGULATION

PCB : Centralised control module management module

T1 : 400/230V single phase transformer

ST1 : Inlet water temperature sensor

ST2 : Outlet water temperature sensor

ST3 : Condensing temperature sensor

ST4 : Outdoor air temperature sensor

SM1 : ON/OFF switch in casing

OCT: Condenser temperature sensor (Heat pump models)

OPTION REMOTE CONTROL OR MULTI CONTROL

F1 : Block fusible + fusible 5x20 0.5A

T2 : transformateur 230V/24V modular

Main block 21-22-23-24: terminals specific to this option

NOT PROVIDED :

SD/N : Day / night changeover

SLS : Load-shedding switch

RANGE AND SETTINGS OF THERMAL PROTECTION / NOMINAL INTENSITY OF THE CONTACTORS (CLASSE AC3)

MODELS	25	30	35	40	50	60	70	80	
FT	range	9 - 14 A	9 - 14 A	9 - 14 A	13 - 18 A	20 - 25 A	20 - 25 A	24 - 32 A	24 - 32 A
	Adjustment	10 A	11.5 A	13 A	17 A	23 A	24 A	28 A	28 A
FT2	range	9 - 14 A	9 - 14 A	9 - 14 A	13 - 18 A	13 - 18 A	13 - 18 A	24 - 32 A	24 - 32 A
	Adjustment	10 A	11.5 A	13 A	14 A	15 A	17 A	26 A	28 A
FT4	range	1.6 - 2.5 A	1.6 - 2.5 A	1.6 - 2.5 A	1.6 - 2.5 A	1.6 - 2.5 A	2.5 - 4 A	2.5 - 4 A	2.5 - 4 A
	Adjustment	1.7 A	1.7 A	1.7 A	2.1 A	2.1 A	3.1 A	3.1 A	3.1 A
FT41/42	range				4 - 6.3 A	4 - 6.3 A	4 - 6.3 A	2.5 - 4 A	2.5 - 4 A
	Adjustment				5.5 A	5.5 A	5.5 A	3.1 A	3.1 A
PE FT5	range	6 - 10 A	6 - 10 A	6 - 10 A	6 - 10 A	9 - 14 A	9 - 14 A	13 - 18 A	13 - 18 A
	Adjustment	6.3 A	6.3 A	6.3 A	6.3 A	11 A	11 A	15 A	15 A
GE FT5	range	6 - 10 A	6 - 10 A	6 - 10 A	6 - 10 A	13 - 18 A	13 - 18 A	17 - 23 A	17 - 23 A
	Adjustment	8 A	8 A	8 A	8 A	14.8 A	14.8 A	19 A	19 A
AC3 CONTACTOR									
K1	12 A	12 A	12 A	18 A	25 A	25 A	32 A	32 A	
K2	12 A	12 A	12 A	18 A	18 A	18 A	32 A	32 A	
K5	9 A	9 A	9 A	9 A	18 A	18 A	18 A	18 A	
K4	9 A	9 A	9 A	9 A	9 A	9 A	9 A	9 A	

PRESSOSTATS SETTING

HP1 : High pressure fixed setting 27,5 bars (400 PSI)

FDP : fixed setting DP on the water circuit 0,05 bar (mod 25/30/35)

MISCELLANEOUS

SHM: Purple shunt to be removed when installing a remote ON/OFF switch between terminals 5 and 6 (40m. maximum).

Note: ON mode = contact closed

ELECTRICAL CONNECTIONS

WARNING



BEFORE CARRYING OUT ANY WORK ON THE EQUIPMENT, MAKE SURE THAT THE ELECTRICAL POWER SUPPLY IS DISCONNECTED AND THAT THERE IS NO POSSIBILITY OF THE UNIT BEING STARTED INADVERTENTLY.

NON-COMPLIANCE WITH THE ABOVE INSTRUCTIONS CAN LEAD TO INJURY OR DEATH BY ELECTROCUTION.

The electrical installation must be performed by a fully qualified electrician, and in accordance with local electrical standards and the wiring diagram corresponding to the unit model.

Any modification performed without our prior authorisation may result in the unit's warranty being declared null and void.

The power supply cable section must be sufficient to provide the appropriate voltage to the unit's power supply terminals, both at start-up and under full load operating conditions.

The power supply cable shall be selected in accordance with the following criteria:

1. Power supply cable length.
2. Maximum unit starting current draw – the cables shall supply the appropriate voltage to the unit terminals for starting.
3. Power supply cables' installation mode.
4. Cables' capacity to transport the total system current draw.

Starting current draw and total current draw are indicated on the unit's wiring diagram.

Short circuit protection shall be provided. This protection shall comprise fuses or circuit breakers with high breaking capacity, mounted on the distribution board.

If the local controls includes a remote ambient temperature sensor and/or a set temperature adjustment module, these shall be connected with shielded cable and shall not pass through the same conduits as the power supply cables as the voltages induced may create reliability faults in the unit's operation.

VERY IMPORTANT:

3N~400V-50HZ

The outdoor unit is equipped as standard with a phase sequence and cut-out controller located in the electrical box.

THIS PRODUCT IS EQUIPPED WITH A PHASE SEQUENCE CONTROLLER. THE LED'S INDICATE THE FOLLOWING CONDITIONS:

Green LED = 1: low voltage supply

the compressor rotation direction is correct

Green LED = flickering: phase inversion

Green LED = 0: phase absent

the compressor and the fans do not start.

These units are equipped with a local switch used as general terminal board.



The switch can be padlocked.

A circuit breaker or fuse holder (not supplied) must be installed on the main power supply of the unit in accordance with the circuit diagram; for the ratings, refer to the electrical specifications.

Models

25 - 30 - 35



Press to unclip and withdraw the "local switch" unit on the terminal board.

Models

40 - 50 - 60 - 70 - 80



3N~400V



Max. tightening torque

- models 25-30-35
2,1Nm
- models 40 - 50 - 60 - 70 - 80
4Nm



Use a pozidrive M3.5 screwdriver, Form Z, to make the connections.

REMOTE ON/OFF SWITCH

connect the remote ON/OFF switch "SHM" between terminals 5 and 6.

SEE APPENDIX

ALL SEASONS KIT (FREQUENCY DRIVE)



WARNING FREQUENCY DRIVE



frequency drive

If the frequency drive is connected to a network with impedance or isolated neutral (IT diagram):

Remove the Ground screw (GND) from the regulator as shown on the diagram below

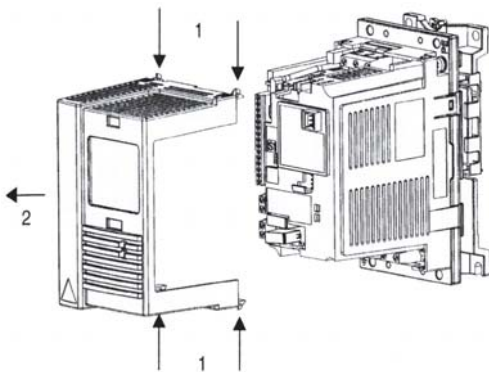

1. Remove the casing

Press down simultaneously on all four spring buttons at the four corners of the appliance.

Remove the casing.

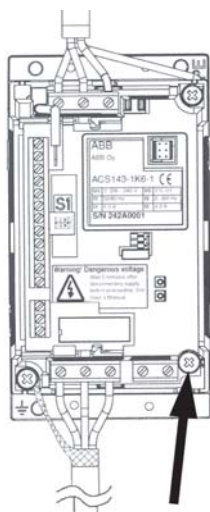

2. Remove the screw

REGULATION

AQCL/AQCH units are supplied with an electronic controlling and monitoring system as a standard. This system will enable the units to perform all control, monitoring and alarm functions.

Alarms management and display

➤ High pressure alarm

When this alarm is triggered, the control system causes the refrigerating circuit to stop and opens the compressor control chain (safety against failures). The alarm is reset by the pressure switch and manually from the control panel.

➤ Low pressure alarm

When this alarm is triggered, the control system causes the refrigerating circuit to stop. The operation of this alarm is delayed for about 30 seconds after the start-up. The alarm is manually reset from the control panel.

➤ Antifreeze alarm

It is triggered when the temperature of the fluid leaving the evaporator drops below 4°C. When this alarm is triggered, the control system causes the refrigerating circuit to stop. The alarm is manually reset from the control panel.

➤ External interlock alarm

When this alarm is triggered, the control system causes the unit to stop. The alarm is automatically reset.

ILTC CONTROL

GENERAL INFORMATION

Main Features

"User Friendly": simple to use, only three keys to access all control functions through menus and sub menus with a tree logic.

Reliability: all the messages are displayed by 4 7-Segment displays, their visibility is excellent even if the environmental visibility is poor.

Special TEST key to start the automatic AutoTest procedure of the machine.

Fuzzy logic smart control of the inlet water temperature to limit the necessity to accumulate water.

Double Setpoint Operation Mode (Night Mode) which may be remotely selected to:

- ◆ reduce electric consumption, or
- ◆ accumulate water at a very low temperature and / or
- ◆ reduce noise

Display of all machine alarms.

Memory record of the latest 10 alarms (Log Menu).

Start / Stop from a remote contact.

Machine alarm state indicated by the terminal board on the SPST contact.

Count of compressors and fans operation hours.

Display and control of all machine thermodynamic parameters (pressures, temperatures, subcooling, overheating, room temperature).

Delivery and suction pressures controlled by transducers.

Maximum discharge temperature control of compressors.

Operation mode by shutting refrigerating capacities, remotely selectable through a terminal board contact (load shedding).

ELECTRONIC BOARD CONTROLS

KEYBOARD

SM1 SWITCH:

position **0**: machine OFF. Electrical resistances might be active.

position **1**: machine ON.

SWITCH >

To scroll the MENUS horizontally and to display the values of parameters.

SWITCH ^

To scroll the MENUS and SUBMENUS vertically and to increase the numeric value of parameters.

SWITCH TEST

Activates an automatic procedure of test of all the principal functions of the unit.

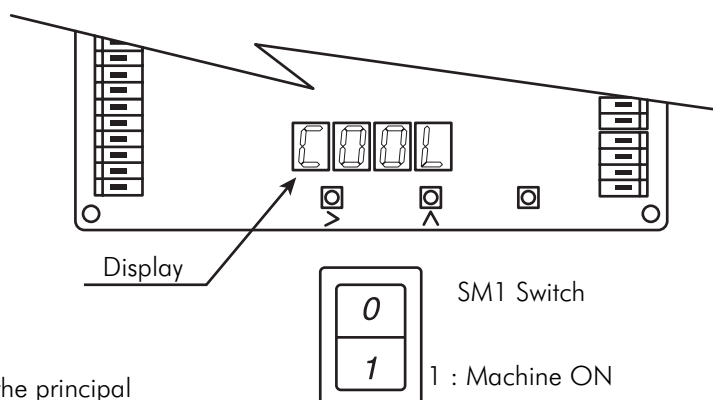

DIP SWITCH

FUNCTION OF DSW1 DIP SWITCHES

DIP	OFF	ON	STANDARD
1	Pump ON only if unit ON	Pump always ON	ON
2	Standard ventilation	Variable speed ventilation	OFF
3	Antifreeze protection pump off	Antifreeze protection pump on	ON
4	Compressor 1 with the stop in mode "load shed" "big compressor"	Compressor 2 with the stop in mode "load shed" "small compressor"	OFF
5	Normal	Slave	OFF
6	Room temperature balance	No balance	ON
7	To enable input 5 of the pump thermal overload	To disable input 5	pack unit = OFF non pack = ON
8	Forced defrost OFF	To enable forced defrost	OFF
9	Serial address		OFF
10	Serial address		OFF
11	Serial address		OFF
12	Serial address		OFF

FUNCTION OF DSW2 DIP SWITCHES

DIP	OFF	ON	STANDARD
1	2E: COMP1 = COMP2 (20-30 & 80)	2D: COMP1 =/ COMP2 (40-70)	OFF 20-25-30-80 ON 40-50-60-70
2	fan2 emergency ventilation HEAT PUMP ONLY	fan1 emergency ventilation HEAT PUMP ONLY	OFF if HP unit 20-25-30 ON if HP unit 40-50-60-70-80
3	Auto changeover ON	Auto changeover OFF	ON
4	Normal	Master	OFF
5	Only cold	Heat pump	Only cold = OFF Heat pump = ON
6	R407C	R22	unit R407C = OFF unit R22 = ON
7	Not used	Not used	OFF
8	Not used	Not used	OFF

DISPLAY



Display

Display keys

All information is displayed on 4 7-segment displays.

Use the > and ^ keys to access the display menus as follows:

ILTC USER MENU INDEX

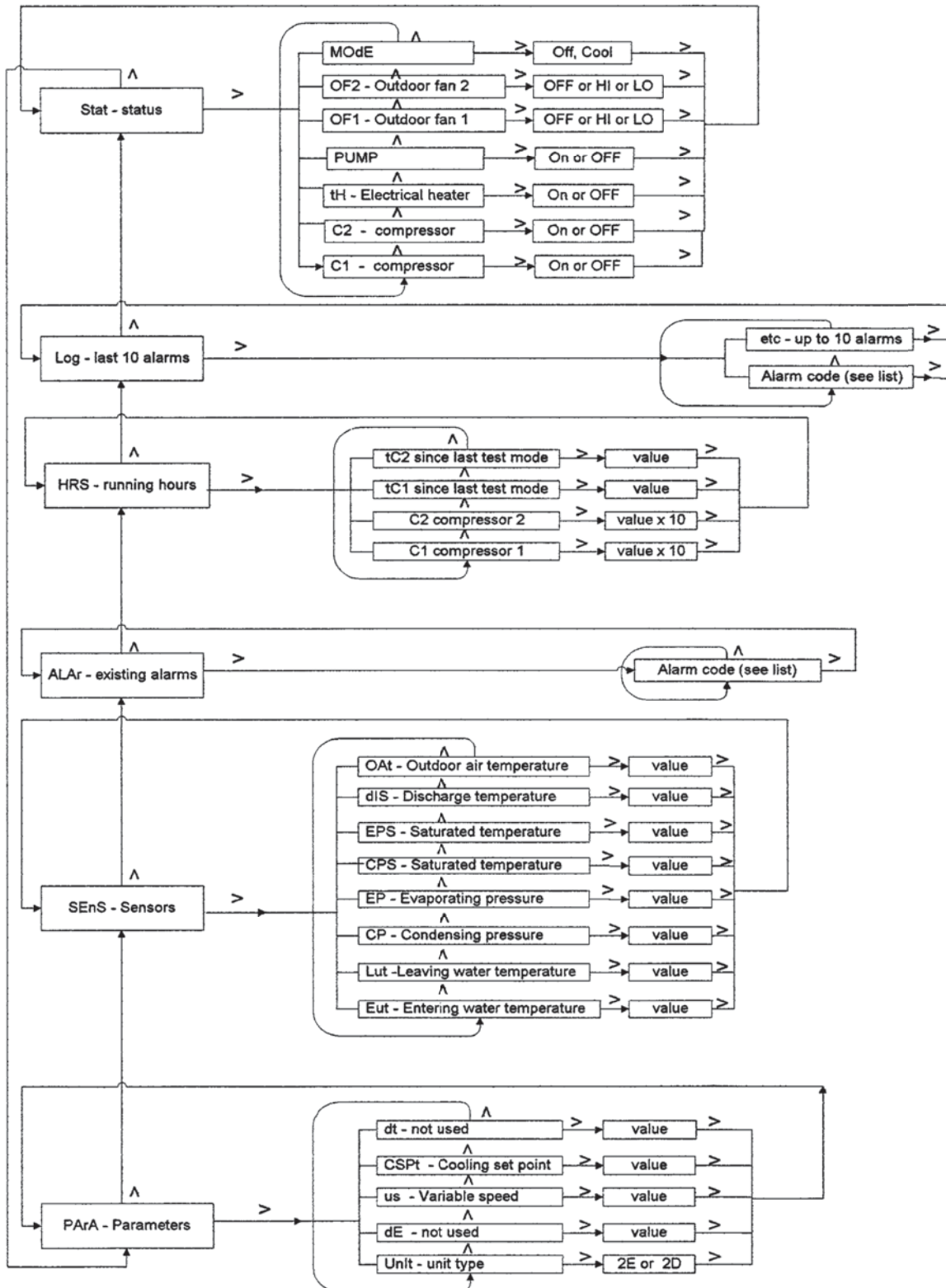

ALAR AND LOG MENU

The ALAR menu is intended to display the active alarms of the unit. Several alarms may be active at the same time. The alarms are recorded in a permanent memory. The LOG menu is intended to display the latest 10 alarms which have been recorded. The table with the alarm codes and descriptions is given here below:

Code	Alarm description	Auto	Manual	Notes
ADC	Microprocessor error		•	
CPF	High pressure transducer failure, out of range	•		
EPF	Low pressure transducer failure, out of range	•		
REF	Refrigerant leak \bar{D} low pressure	•		
CPnc	High pressure transducer failure, pressure unchanged	•		
EPnc	Low pressure transducer failure, pressure unchanged	•		
CFC1	Compressor 1 failure		•	wrong rotation
CFC2	Compressor 2 failure		•	wrong rotation
EWTH	Return water feeler failure	•		short-circuit
EWTL	Return water feeler failure	•		not connected
LWTC	No outlet water temperature change	•		
LWTH	Outlet water feeler failure	•		short-circuit
LWTL	Outlet water feeler failure	•		not connected
LWLH	Compressors delivery temperature feeler failure	•		short-circuit
DISL	Compressors delivery temperature feeler failure	•		not connected
OATH	Air temperature feeler failure	•		short-circuit
OATL	Air temperature feeler failure	•		not connected
OCTL	Battery temperature feeler failure	•		not connected
HPP	First high pressure protection	•		compressor stop
HP	High pressure protection	•		auto reset 3 times
HPC	High pressure protection \bar{D} high pressure switch		•	
LP	Low pressure protection		•	
DIS	Compressors delivery temperature too high	•		
LO	Outlet water temperature too low	•		
HI	Inlet water temperature too high	•		
FS	Differential water flow or pressure switch		•	
CF1	Compressor 1 thermal load protection		•	
CF2	Compressor 2 thermal load protection		•	
OF1	Fans thermal load protection		•	
PF	Pump thermal load protection		•	
LOu	Low water volume	•		
EEP	Microprocessor error		•	
JUMP	Wrong DIP configuration		•	check DIP
ConF	Wrong configuration		•	

SENS MENU - SENSORS READOUT

Display Code	Meaning
EWT	Inlet water temp
LWT	Outlet water temp
CP	Delivery pressure
EP	Suction pressure
CPS	Delivery saturated temperature
EPS	Suction saturated temperature
Dis	Compressor delivery temperature
OAT	Ambient air temperature
OCT	Battery feeler temperature

PARAMETERS LEVEL**PARA MENU - USER LEVEL ***

Parameter Code	Meaning
Unit	2E or 2D (see DSW2 dip1)
DE	Not used
Vs	Fans speed analogue output
CSPT	Cooling setpoint on
HSPT	Heating setpoint on
dt	Internal timer
EPIC	Internal parameter ⌀ not used
td	Last defrost duration

* READ ONLY

SERVICE LEVEL PARAMETERS

Press the two > and ^ keys at the same time for 5 seconds to have access to the following list of parameters:

Display	Meaning	Min. value	Max. value	Step	Default value
OPER	Operation mode	COOL	HEAT		COOL
CSP	Cooling setpoint	CSPL	23	0.5	12°C
HSP	Heating setpoint	20	50	1	40°C
gly	Glycol percentage	0	50	5	0%
nigh	Night Mode Configuration	1	4	1	2
COAL	CSPT balance: min OAT	10	30	2	20°C
COAH	CSPT balance: max OAT	20	36	2	30°C
CDCO	Balanced CSPT offset	0	8	1	6°C
HDCO	Balanced HSPT offset	0	15	1	8°C
HOAL	HSPT balance: min OAT	-10	10	1	-5°C
HOAH	HSPT balance: max OAT	0	20	1	10°C
ACO	Automatic change over	10	30	1	20°C
nD	Night Mode CSPT differential (1-2)	0	5	1	2°C
nFC	Night Mode condensation change (2)	-4	4	1	2bar
V1	OFAN coefficient for FSC (cooling)	0	4	0.2	1
V2	OFAN coefficient for FSC (cooling)	0	0.7	0.05	0.5
V3	OFAN coefficient for FSC (heating)	5	30	1	19
V4	OFAN coefficient for FSC (heating)	0	3	0.1	0.6
Vlo	OFAN coefficient for FSC	0	3	0.1	2
LELA	Lead Lag (compressors rotation)	Off	On		On
F0	Factory level access	0	9	1	0
F1	Factory level access	0	9	1	0
F2	Factory level access	0	9	1	0

COMMISSIONING

PRE-START CHECK LIST

ELECTRICAL CHECK

1. Electrical installation has been carried out according to unit wiring diagram and the Supply Authority Regulations.
2. Correct size fuses or circuit breaker installed at switchboard.
3. Supply voltages as specified on unit circuit diagram.
4. All terminals right.
5. Wiring clear of or protected from pipework and sharp edges.

HYDRAULIC CHECKS

1. Check that the external water circuit components (pumps, user equipment, filters, expansion tank and reservoir if supplied) have been correctly installed in accordance with the manufacturer's recommendations and that the water inlet and outlet connections are correct.
2. Check that the hydraulic circuit is filled correctly and that the fluid flows freely without any signs of leaks or air bubbles. When ethylene glycol anti-freeze is used, check that the concentration level is correct.
3. Check the direction of rotation of the pump and leave the fluid to circulate for at least 12 hours for each pump. Then clean the pump inlet water filter.
4. Adjust the water flow in order to comply with the specifications.
5. Check that the water quality complies with the indicated standards.
6. Check that the oil heating resistances have been energised for at least 12 hours.

VISUAL CHECK

1. Clearance around unit including condenser air entry and discharge and service access.
2. Unit mounted as specified.
3. For loose or missing bolts or screws.
4. For refrigerant leaks in connections and components.

DUCTING

1. Connections flexible type, secure and detachable for service access.
2. Seams and joints airtight.
3. Fan drive
Pulley adjustment correct for expected air quantity and static pressure.
Belt tension correct.
4. Check that the Biloc Sheaves on both the fan shaft and the motor are correctly fitted to the bush and rotate without wobble.
5. Ensure that the motor is securely bolted to the mounting plate square to the fan shaft.
6. Using a string line or straight edge ensure that the pulley grooves are correctly aligned.
7. Improper alignment of the pulleys and belt may cause vibration in the fan drive and result in premature wear.

OPERATING CHECK LIST

PLEASE NOTE READ THE ELECTRONIC CONTROLS OPTION FOR CAC CONTROLER BEFORE PROCEEDING.

GENERAL

Cheek for any unusual noises or vibration in the running components, particularly the indoor fan drive system.

PHASE ROTATION PROTECTION

If the phase rotation is not correct, the phase rotation protection device will prevent the machine from starting.

ELECTRICAL

SET POINTS

1. Set point of compressor overload relay.
2. Set point of indoor fan motor overload relay.

NOTE : The outdoor fan motor is fitted with an internal automatic reset overload device.

OPERATING VOLTAGE:

Recheck voltage at unit supply terminals.

CONTROL

1. Operate system switches and control thermostat.
2. Check unit is wired for correct control of unit fan, cooling and heating functions.
3. Verify all sensor input, using the ILTC controller display.

FAN & DRIVE

1. Check that the Sheaves on both the fan shaft and the motor are correctly fitted to the bush and rotate without wobble.
2. Check the alignment of the pulleys
3. Rotation: Cheek direction of rotation.
4. Static Pressure Loss and Air Quantity
5. The indoor air quantity must be within the application limits of the unit supply air fan (see fan curves). The associated static pressure must be such that the motor is operating within its normal power rating. With all panels in place measure current in each phase of the indoor fan motor using clip-on type ammeter. Compare this to the nameplate full load current.

COMPRESSOR AND REFRIGERATION SYSTEM

1. If outdoor air temperature is below zero make sure that the compressor crankcase heater has been on for at least one hour before starting compressor.
2. Running check: Start the compressor. Check for any unusual noise and vibration.
3. Operating Pressures: Operate the unit for a minimum of 20 minutes to ensure that the refrigerant pressures have stabilised, and cheek that they are within normal operating limits.
4. Operating Temperature: Check discharge, suction and liquid temperatures.
5. Discharge temperature on cooling cycle should normally not exceed 105°C.
6. Suction superheat should be 6°C ±2°C.

HYDRAULIC CIRCUIT

**TO PUT OUT OF WATER THE CIRCUIT BEFORE THE STARTING OF THE PUMP
WHEN ETHYLENE GLYCOL ANTI-FREEZE IS USED, CHECK THAT THE
CONCENTRATION LEVEL IS CORRECT.**

SEE APPENDIX

1. Start the liquid pump and check that the water flow is within the prescribed rates.
2. Programme the desired inlet fluid temperature on the control panel.
3. After about 15 minute's operation, check that there are no air bubbles in the liquid pipe by looking through the liquid inspection porthole.



The presence of air bubbles means that the unit has lost some of its refrigerant charge via one or several leakage points that should be eliminated.

- Plug the leaks.
- Check the oil level.

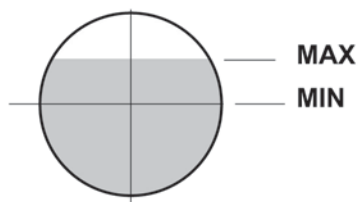

FINAL CHECK

1. All panels and fan guards in place and secure.
2. Unit clean and free of excess installation material.

FINAL TASKS

Place the plugs back on the valves and check that they are properly tightened.

If needed, fix the cables and the pipes on the wall with clamping collars.

Operate the air conditioner in the presence of the user and explain all functions.

Show him how to remove, clean and place back the filters.

Take care

It is not the manufacturer's policy to make recommendations in terms of water treatment (please contact a specialised water treatment company).

However, given the critical nature of this subject, particular care should be taken to ensure that, if treatment is required, it works effectively.

Using untreated or unsuitable water leads to excessive clogging inside the coil (earth and mud deposits, corrosion, etc.) with major consequences on the thermal efficiency of the unit and irreversible damage to the equipment.

The manufacturer and its representative decline all responsibility in the event of untreated or incorrectly treated water being used.

IN-WARRANTY RETURN MATERIAL PROCEDURE

Material must not be returned without permission of our After Sales Department.

To return the material, contact your nearest sales office and ask for a "return voucher". This return voucher shall be sent out with the returned material and shall contain all necessary information concerning the problem encountered.

The return of the part does not constitute an order for replacement. Therefore, a purchase order must be entered through your nearest distributor or regional sales office. The order should include part name, part number, model number and serial number of the unit involved.

Following our personal inspection of the returned part, and if it is determined that the failure is due to faulty material or workmanship, and in warranty, credit will be issued on customer's purchase order. All parts shall be returned to our factory, transportation charges prepaid.

SERVICE AND SPARE PARTS ORDER

The model number, the confirmation number and the unit serial number indicated on the name plate must be provided whenever service works or spare parts are ordered.

For any spare part order, indicate the date of unit installation and date of failure. Use the part number provided by our service spare parts, if it not available, provide full description of the part required.

MAINTENANCE



The user is responsible for ensuring that the unit is in proper working order and that technical installation as well as the regular maintenance operations are performed by properly trained technicians and in accordance with the instructions contained in this manual.

REGULAR MAINTENANCE

These units have been designed for minimum maintenance through the use of permanently lubricated components. However, there are operational maintenance requirements that require regular attention to ensure optimum performance.

Maintenance must be performed by appropriately experienced personnel.

WARNING : Isolate unit from power supply before working on unit.

REMOVAL OF PANELS

All access panels are removable by unscrewing the self tapping retaining screws.

FAN DRIVE SYSTEM

Fan shaft and motor bearings are of permanently lubricated, sealed type and require no regular maintenance other than a check on their general condition. The fan belt tension should be checked regularly and belt surfaces inspected for cracks or excessive wear. The belt should be tensioned to give a 20 mm deflection under medium pressure with the thumb on one of the straight runs.

COILS

The coil surface will become laden with dust and maybe blocked by leaves or papers over a period of time. Coils should be inspected periodically and cleaned down by hosing or steam cleaning as required.

ELECTRICAL

The contact surfaces of relays and contactors should be inspected regularly by an electrician and replaced as judged necessary. On these occasions the control box should be blown out with compressed air to remove any accumulation of dust or other contaminants.

REFRIGERATION

The refrigeration system is hermetically sealed and should require no regular maintenance. However, it is recommended that the system must be leak tested and the general operating and control systems be checked on a regular basis. The operating pressures should be checked particularly as they are an excellent guide of the system in need of maintenance.

SERVICING CHECKLIST

CABINET

1. Clean the outer panels.
2. Remove the panels.
3. Check that the insulation is not damaged. Repair as required.

CONDENSATE DRAINAGE TRAY

1. Check that the drainage orifices and conduits are not blocked.
2. Eliminate all accumulated dirt.
3. Check that no traces of rust are present.

REFRIGERATING CIRCUIT

1. Check the absence of gas leaks.
2. Check that the conduits or the capillaries do not rub against anything or vibrate.
3. Check that the compressors do not generate any abnormal noises or vibrations.
4. Check the compressor output temperature.
5. Check that the sump heater is energised during the Stop cycle.

BATTERIES

1. Clean the fin surfaces as required.
2. Observe the condition of the fans and motors.
3. Clean the filters.
4. Check the condition of the fan and the fan motor.

CONDENSER

1. Check the cleanliness of the fin surfaces.
2. Check the condition of the fan and the fan motor.
3. Check the condition of the drive pulleys and the drive belt.
4. Check the drive belt tension.
5. Check for signs of wear on the fan bearings.

PROTECTION DEVICES

Check the proper operation of the high pressure regulation system.

ELECTRICAL EQUIPMENT

1. Check nominal current draw and the condition of the fuses.
2. Check the tightness of the screw terminals.
3. Perform a visual check of the condition of the contacts.
4. Check the general tightness of all cable connections.

Refit the panels and replace any missing screws.

CAUTION

BEFORE CARRYING OUT ANY OPERATION ON THE EQUIPMENT, CHECK THAT THE ELECTRICAL POWER SUPPLY IS SWITCHED OFF AND THAT IT CANNOT BE SWITCHED ON INADVERTENTLY.

IT IS RECOMMENDED THAT THE LOCAL SWITCH BE PADLOCKED

TROUBLE SHOOTING

Problem	Probable cause	Solution
Unit operates continuously but without generating cooling	Insufficient refrigerant fluid charge.	Top up the refrigerant fluid charge.
	Clogged dehumidification filter.	Replace the dehumidification filter.
	Reduced output from one or both circuits	Check the compressor valves and change them if necessary.
Frozen intake line	The overheating setting on the thermostatic pressure relief valve is too low.	Increase the setting.
		Check the refrigerant fluid charge
Excessive noise	Vibrating pipe work	Attach the pipe work correctly.
		Check the pipe work attachments.
	Whistling noise from the thermostatic pressure relief valve	Top up the refrigerant fluid charge.
		Check and replace the dehumidification filter if necessary.
	Noisy compressor	Check the condition of the valves.
		Seized bearings. Replace the compressor
Low oil level in the compressor		Check the tightness of the compressor attachment nuts.
	Presence of one or several oil or gas leaks in the circuit	Locate and repair the leaks
	Mechanical compressor damage.	Contact an approved Service Centre.
One or both compressors do not operate.	Sump oil heater resistance fault.	Check the electrical circuit and the condition of the resistance. Replace defective parts if necessary.
	Electrical circuit cut.	Check the electrical circuit and seek out any grounding and/or short- -circuits. Check the fuses.
	High pressure pressostat activated.	Reset the pressostat from the control panel and restart the unit. Identify and eliminate the causes of this activation.
	Control circuit fuse blown.	Check the control circuit and seek out any grounding and/or short-circuits. Replace the fuses.
	Connection problem	Check the tightness of all the electrical connection terminals.
	Electrical circuits thermal protection cuts in.	Check the operation of the control and safety devices. Identify and eliminate the cause of the activation.
	Incorrect wiring.	Check the wiring of the control and safety devices.
	Mains voltage too low.	Check the power line. Eliminate any possible problems associated with the system. If the problem is due to the network, inform the Electricity Company.
	Compressor motor short-circuited.	Check the continuity of the motor winding.
Compressor seized	Replace the compressor.	
Circuit stoppage further to the low pressure thermostat being activated.	Presence of a leak.	Identify and repair the leak.
	Insufficient refrigerant fluid charge.	Top up the refrigerant fluid charge.
	Pressostat operating fault.	Replace the pressostat.
Circuit stoppage further to the high pressure thermostat being activated.	Incorrect operation of the high pressure pressostat.	Check the operation of the pressostat. Replace it if required.
	Outlet valve partially closed.	Open the valve. Replace it if required.
	Non-condensable particles in the circuit.	Bleed the circuit
	Condenser fan(s) not operating.	Check the wiring and the motors. Repair and replace if required.
Liquid line too hot	Insufficient refrigerant fluid charge.	Locate and eliminate the causes of charge losses and top up the refrigerant fluid charge.
Liquid line frozen	Liquid line valve partially closed.	Checking the opening of all the valves.
	Clogged dehumidification filter.	Replace the filter cartridge.
Fans do not operate.	Electrical circuit problems.	Check the connections.
	Internal circuit thermal cut-out activated.	Contact an approved Service Centre.

Problem	Probable cause	Solution
Reduced output in both Heating and Cooling mode	Compressor operating fault	Contact an approved Service Centre.
	Dirt in the evaporator water circuit.	Chemical cleaning of the evaporator water circuit.
	Condenser battery blocked.	Clean the condenser battery.
	Insufficient refrigerant fluid charge.	Top up the refrigerant fluid charge.
Evaporator heater is not operating.	No power supply.	Check the main fuse and the auxiliary fuses.
	Heater circuit open	Check the heater and replace if required.
No/ little control over water temperature.	Incorrect thermostat setting.	Check the temperature setting on the control panel.
	Incorrect temperature differential between evaporator inlet and outlet.	Check the water flow and the quantity of liquid in the water circuit.
	Electronic control system malfunction.	Contact an approved Service Centre.
Insufficient water circulation.	Air in the circuit	Bleed the air via the safety valve.
	Deposits or impurities in the evaporator.	Wash out the evaporator by back-flushing.
Unit not operating, no alarm activation	Water circulation fault	Check the pump.
	Flow controller inoperable.	Check the flow controller.
	Differential pressostat inoperable.	Check the differential pressostat.

APPENDIX
ANNEXE
ANLAGE
ALLEGATO
ANEXO

APPENDIX

AERUAIC ADJUSTABLE.....	III
WIRING DIAGRAM	IV
AERUAIC ADJUSTMENT	XI
REFRIGERANT CIRCUIT DIAGRAM	XV
HYDRAULIC CIRCUIT DIAGRAM	XVII
WATER FLOW DETECTOR FOR MODELS 25-30-35.....	XX
HYDRAULIC CHARACTERISTICS.....	XXI

ANNEXE

SYSTEME AERUAIQUE REGLABLE	III
SCHEMAS ELECTRIQUES	IV
CARACTÉRISTIQUES AÉRAULIQUES	XI
SCHEMA DU CIRCUIT FRIGORIFIQUE	XV
SCHEMA DU CIRCUIT HYDRAULIQUE	XVII
DETECTEUR DE DEBIT D'EAU POUR MODELES 25-30-35	XX
CARACTÉRISTIQUES HYDRAULIQUES.....	XXI

ANLAGE

REGELBARES LÜFTERSYSTEM	III
STROMLAUFPLANS.....	IV
REGELUNG DES LÜFTERSYSTEMS	XI
KÄLTEKREISLAUFDIAGRAMM.....	XV
HYDRAULISCHER SCHALTPLAN.....	XVII
WASSERMENGENMESSFÜHLER FÜR MODELLE 25-30-35	XX
HYDRAULISCHE DATEN	XXI

ALLEGATO

SISTEMA TRATTAMENTO DELL'ARIA REGOLABILE	III
SCHEMA ELETRICO	IV
REGOLAZIONE DEL SISTEMA DI TRATTAMENTO DELL'ARIA.....	XI
SCHEMA DEL CIRCUITO REFRIGERANTE	XV
SCHEMA CIRCUITALE IDRAULICO	XVII
RILEVATORE DI PORTATA DELL'ACQUA PER MODELLI 25-30-35.....	XX
CARATTERISTICHE IDRAULICHE	XXI

ANEXO

SISTEMA AEROLICO AJUSTABLE.....	III
ESQUEMA ELECTRICO.....	IV
AJUSTE DEL SISTEMA AEROLICO	XI
ESQUEMA DEL CIRCUITO FRIGORIFÍCO.....	XV
ESQUEMA CIRCULAR HIDRÁULICO.....	XVII
DETECTOR DE CAUDAL DE AGUA PARA LOS MODELOS 25-30-35	XX
CARACTERÍSTICAS HIDRÁULICAS	XXI

AERAILIC ADJUSTABLE
SYSTEME AERAILIQUE REGLABLE
REGELBARES LÜFTERSYSTEM
SISTEMA TRATTAMENTO DELL'ARIA REGOLABILE
SISTEMA AEROLICO AJUSTABLE

Adjustment belt tightening
 Réglage du serrage de la courroie
 Einstellen der Riemenspannung
 Regolazione del serraggio della cinghia
 Ajuste del apriete de la correa

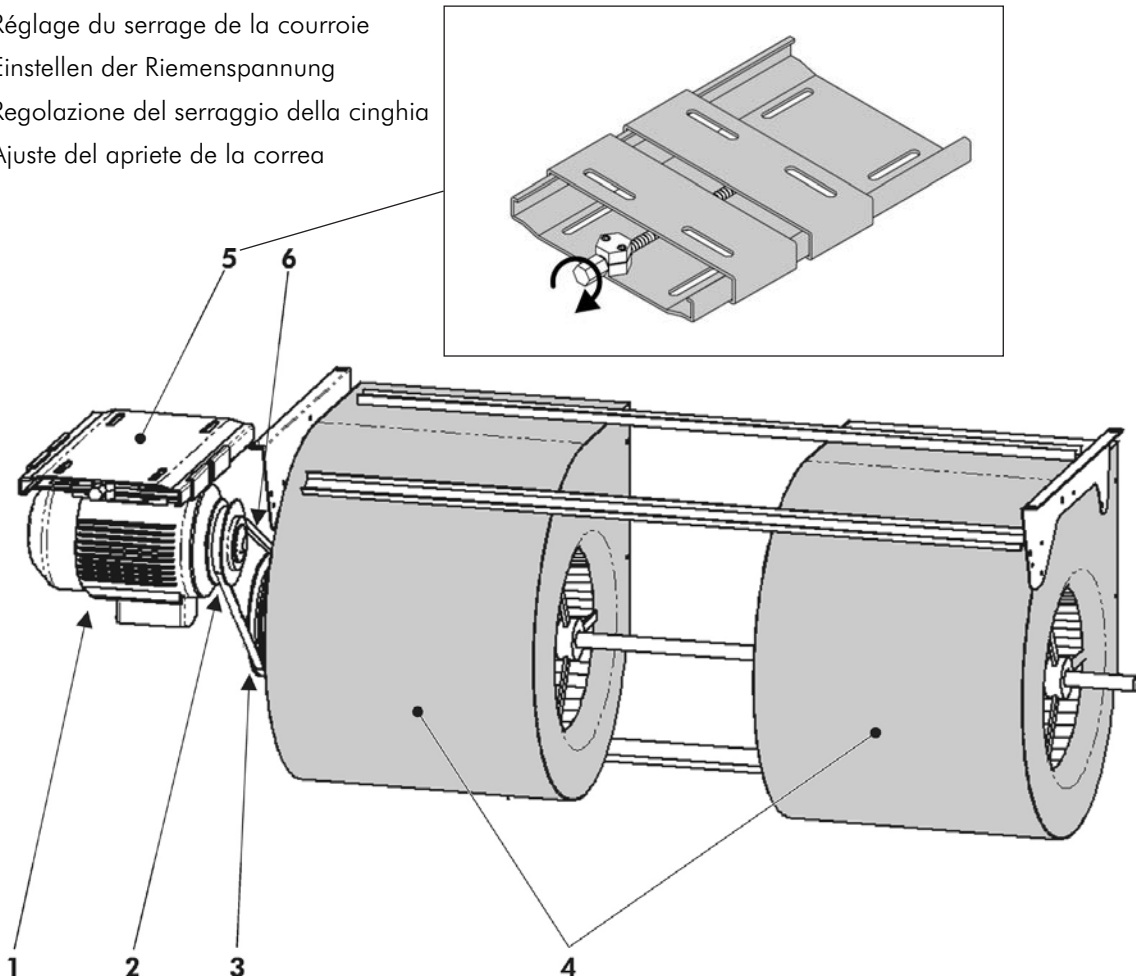

1	Motor fan	Moteur des ventilateurs	Motor der Ventilatoren
2	Variable pulley	Poulie variable	Einstellbare Riemenscheibe
3	Fixed pulley	Poulie fixe	Feste Riemenscheibe
4	Centrifugal fan	Ventilateur centrifuge	Zentrifugalventilator
5	Sliding motor support	Support coulissant du moteur	Gleitender Motorbock
6	Belt	Courroie	Riemen

1	Motore dei ventilatori	Motor de los ventiladores
2	Puleggia variabile	Polea variable
3	Puleggia fissa	Polea fija
4	Ventilatore centrifugo	Ventilador centrifugo
5	Supporto scorrevole del motore	Soporte deslizando del motor
6	Cinghia	Correa

WIRING DIAGRAM

SCHEMAS ELECTRIQUES

STROMLAUFPLANS

SCHEMA ELETRICO

ESQUEMA ELECTRICO

TAKE CARE!

These wiring diagrams are correct at the time of publication. Manufacturing changes can lead to modifications. Always refer to the diagram supplied with the product.

ATTENTION

Ces schémas sont corrects au moment de la publication. Les variantes en fabrication peuvent entraîner des modifications. Reportez-vous toujours au schéma livré avec le produit.

ACHTUNG!

Diese Stromlaufplans sind zum Zeitpunkt der Veröffentlichung gültig. In Herstellung befindliche Varianten können Änderungen mit sich bringen. In jedem Fall den mit dem Produkt gelieferten Stromlaufplan hinzuziehen.

ATTENZIONE !

Questi schemi sono corretti al momento della pubblicazione. Le varianti apportate nel corso della fabbricazione possono comportare modifiche. Far sempre riferimento allo schema fornito con il prodotto.

ATENCIÓN !

Esto esquemas son correctos en el momento de la publicación. Pero las variantes en la fabricación pueden ser motivo de modificaciones. Remítase siempre al esquema entregado con el producto.

**POWER SUPPLY MUST BE SWITCHED OFF BEFORE STARTING TO
WORK IN THE ELECTRIC CONTROL BOXES!**



**MISE HORS TENSION OBLIGATOIRE AVANT TOUTE INTERVENTION
DANS LES BOITERS ELECTRIQUES.**

**VOR JEDEM EINGRIFF AN DEN ANSCHLUßKÄSTEN UNBEDINGT
DAS GERÄT ABSCHALTEN!**

**PRIMA DI OGNI INTERVENTO SULLE CASSETTE ELETTRICHE
ESCLUDERE TASSATIVAMENTE L'ALIMENTAZIONE !**

**PUESTA FUERA DE TNESIÓN OBLIGATORIA ANTES DE CUALQUIER
INTERVENCIÓN EN LAS CAJAS ELÉCTRICAS!**

25 30 35 POWER

POWER WIRING DIAGRAM	
MOD. AQCL/AQCH 25/30/35	
SE 3288A	LEGEND N728

BK	BLACK
BRN	BROWN
BLU	BLUE
GRN/YEL	GREEN/YELLOW
GRY	GREY
ORG	ORANGE
OG	OLIVE
WHT	WHITE

OPTIONAL
HEATPUMP MOD.

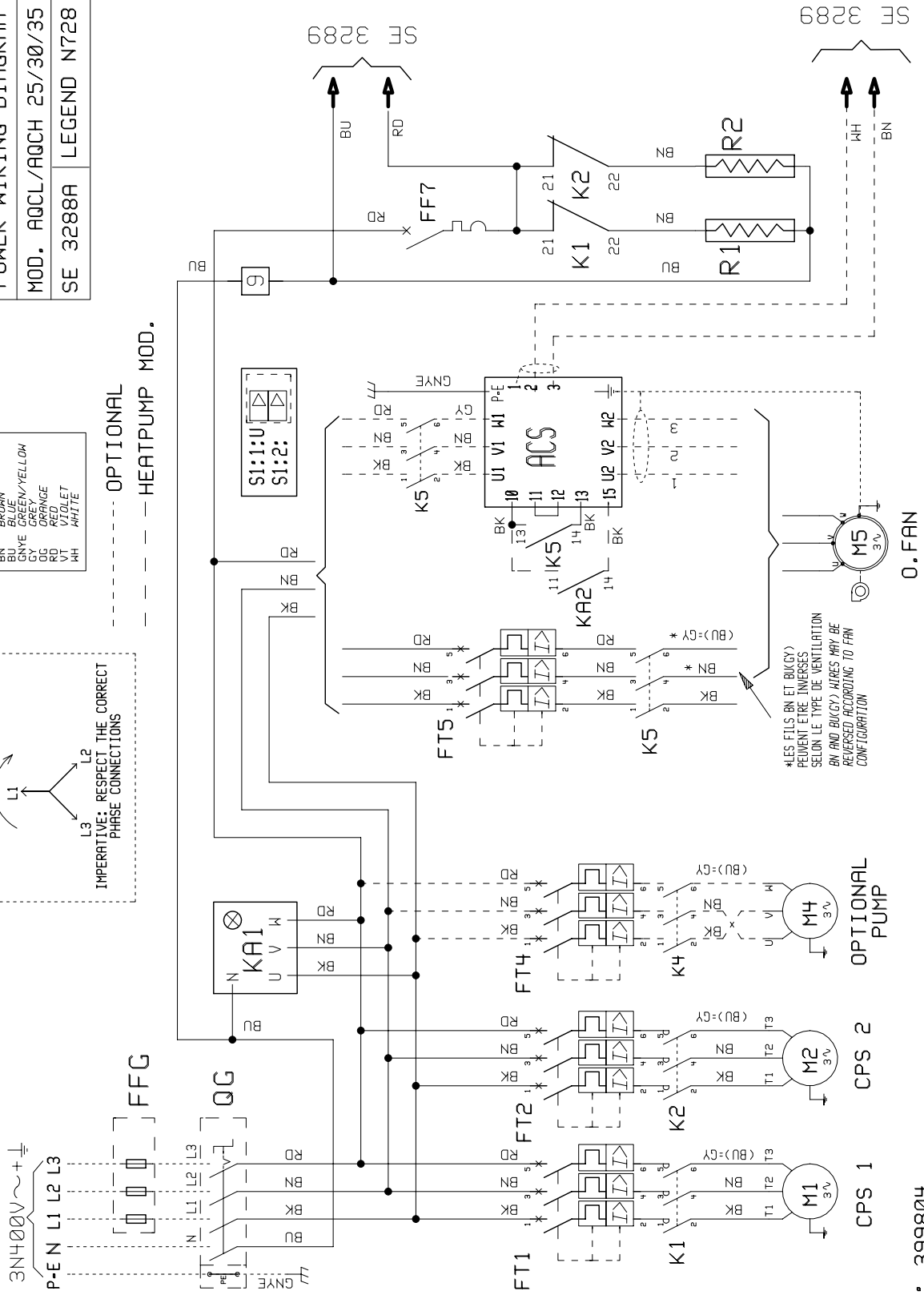
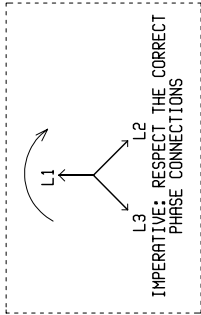

* LES FILS BN ET BK(CY) PEUVENT ÊTRE INVERSÉS SELON LE TYPE DE VENTILATION (BN AND BK(CY) WIRES MAY BE REVERSED ACCORDING TO FAN CONFIGURATION)

CODE: 399804

APPENDIX / ANNEXE / ANLAGE / ALLEGATO / ANEXO

25 30 35 COMMAND

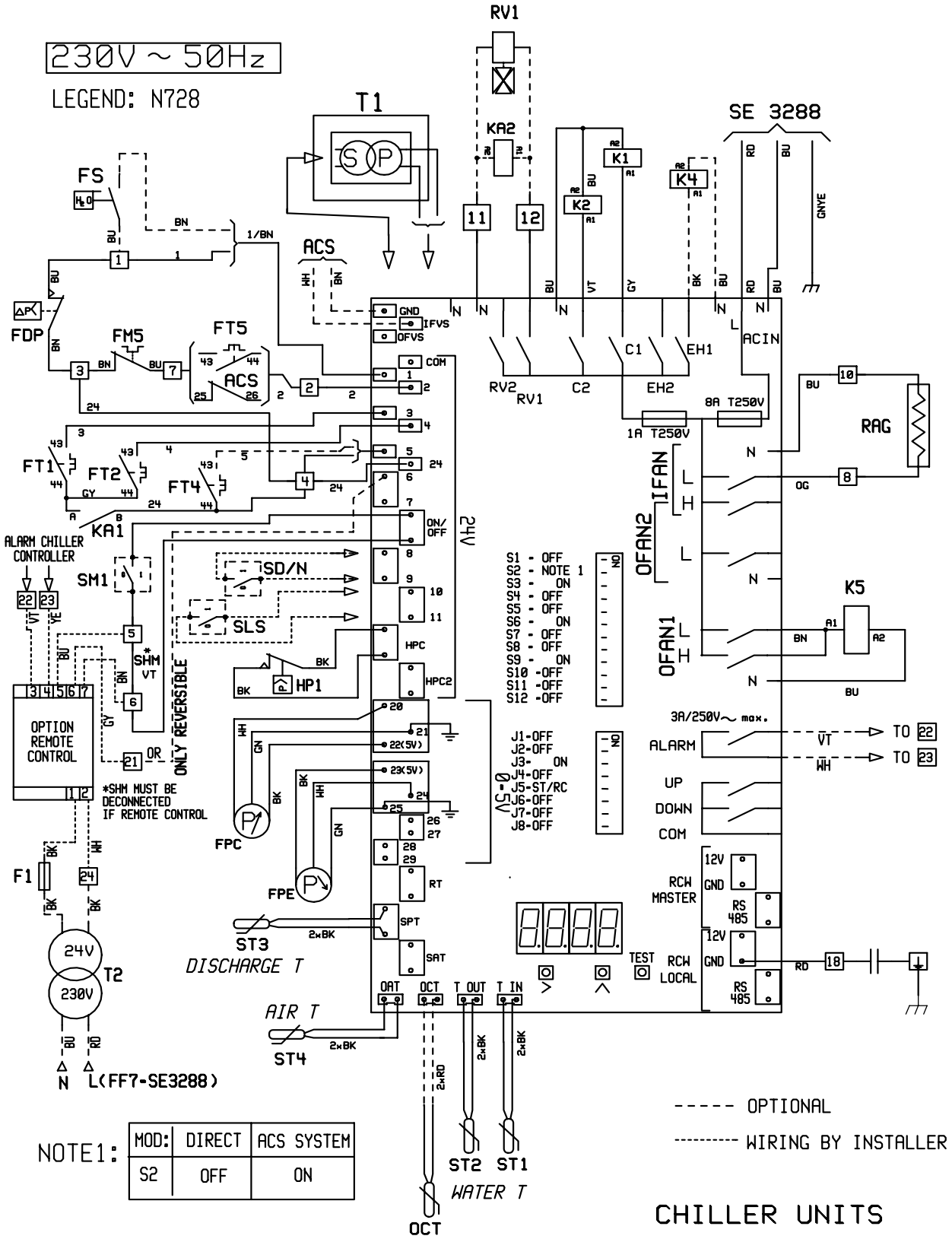

40 50 60 70 80 POWER

POWER WIRING & OPTION

AOCL&AOCH 40/50/60/70/80	
SE 3313A	399809
LEGEND N 728	

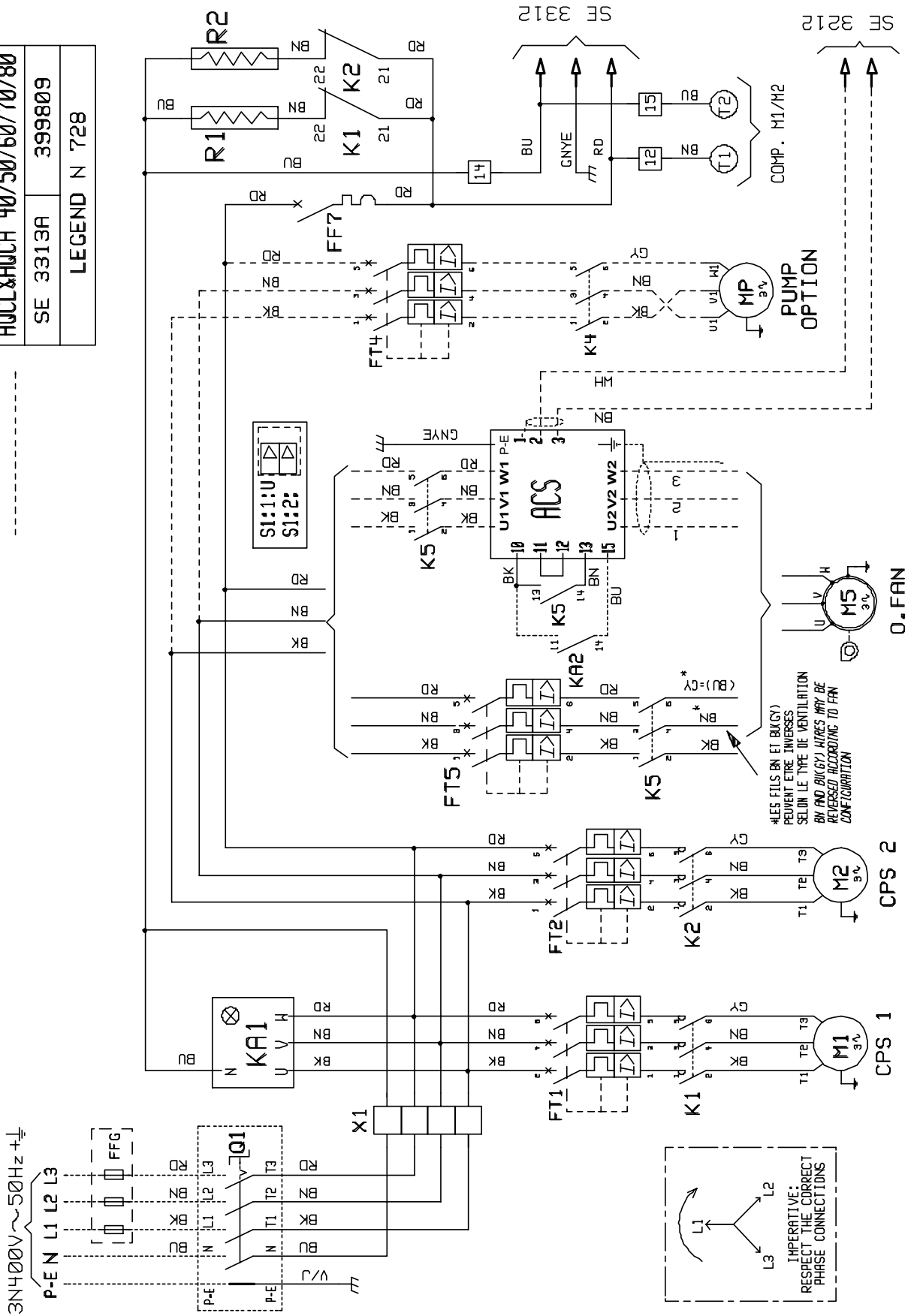

40 50 60 70 80 COMMAND

AQCL/AQCH 40/50/60/70/80 CONTROL

230V ~ 50Hz

LEGEND: N728

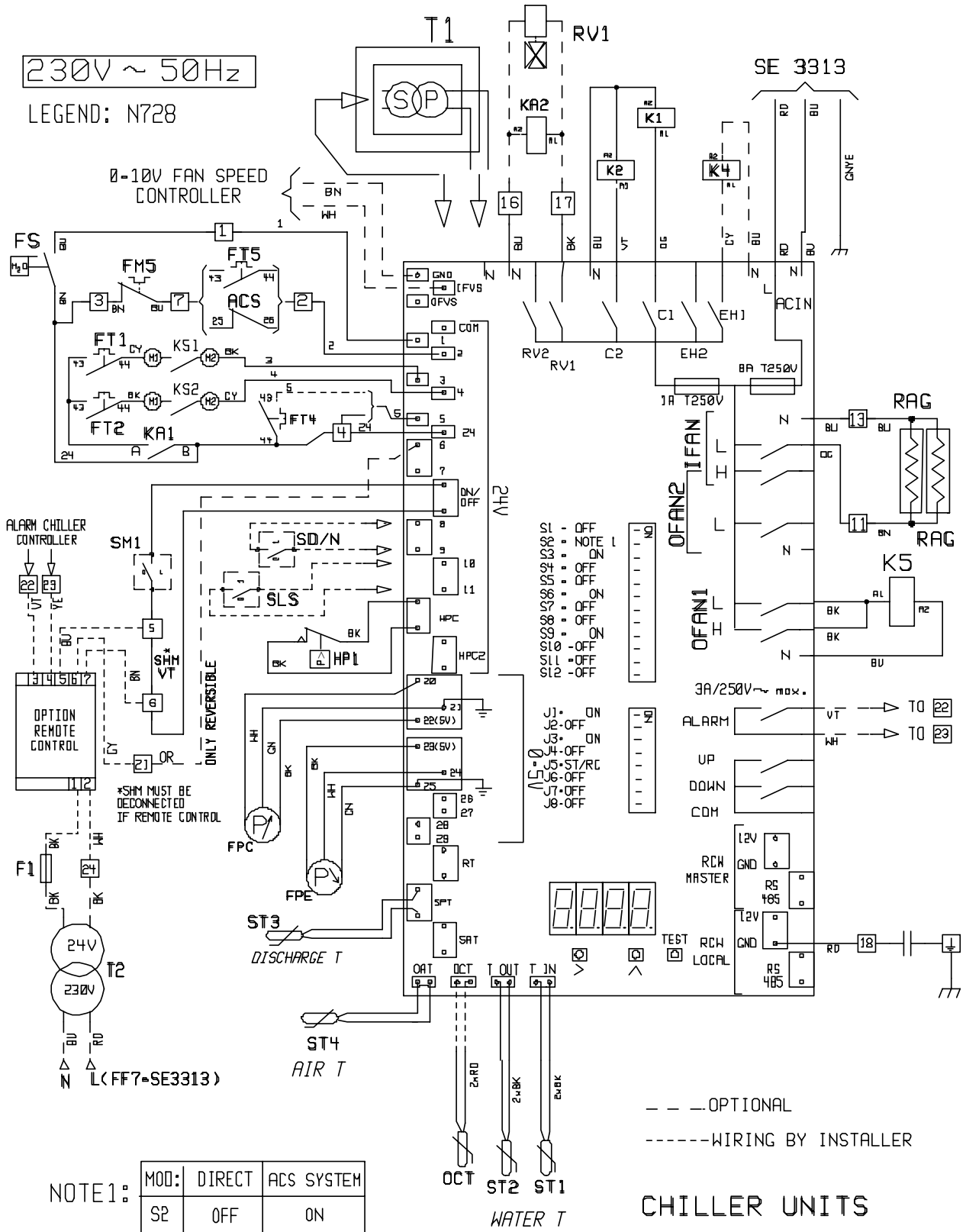

NOTE 1:

MOD:	DIRECT	ACS SYSTEM
S2	OFF	ON

--- OPTIONAL
 - - - - - WIRING BY INSTALLER

CHILLER UNITS
 SE 3312C CODE:399808

40 50 60 70 80 POWER (DOUBLES PUMPS)

POWER WIRING

AQCL&AQCH 40/50/60/70/80 + DOUBLE PUMP	
SE 3371	399825
LEGEND N 728	

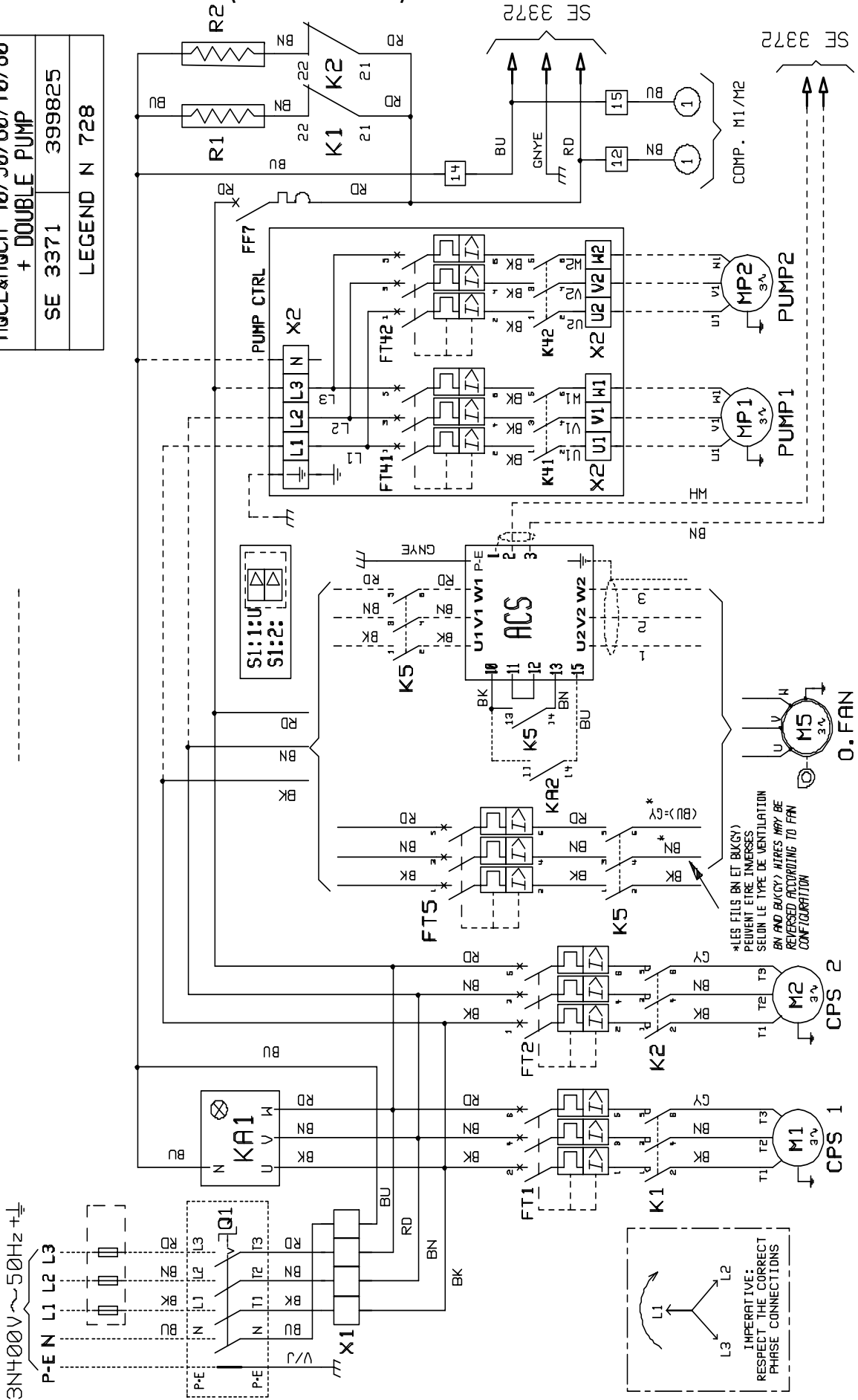

APPENDIX / ANNEXE / ANLAGE / ALLEGATO / ANEXO

40 50 60 70 80 COMMAND (DOUBLES PUMPS)

AQCL/AQCH 40/50/60/70/80 CONTROL DOUBLE PUMP

230V ~ 50Hz

LEGEND: N728

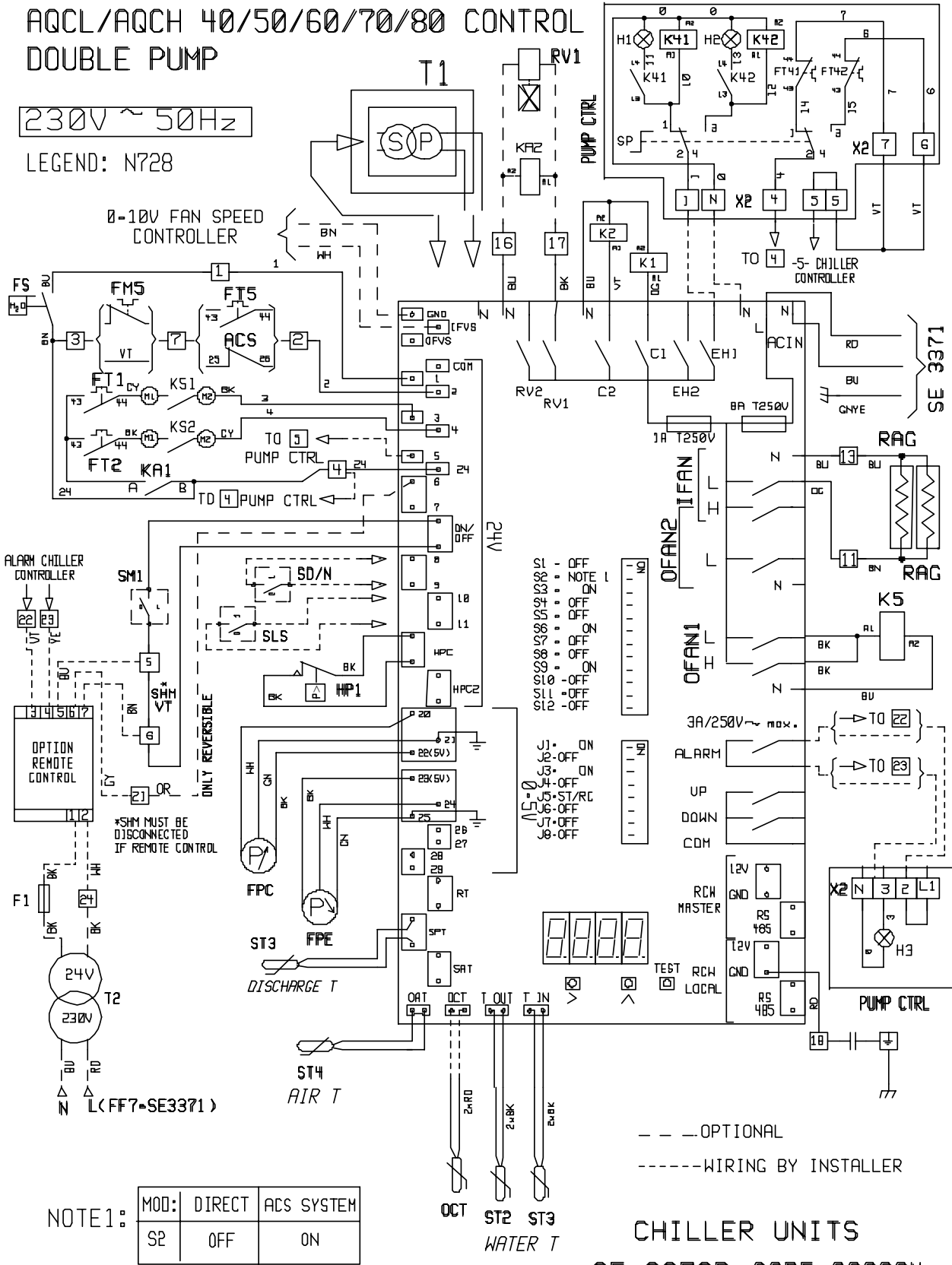

NOTE 1:

MOD:	DIRECT	ACS SYSTEM
S2	OFF	ON

CHILLER UNITS
SE 3372B CODE: 399824

AERAILIC ADJUSTMENT

CARACTÉRISTIQUES AÉRAULIQUES

REGELUNG DES LÜFTERSYSTEMS

REGOLAZIONE DEL SISTEMA DI TRATTAMENTO DELL'ARIA

AJUSTE DEL SISTEMA AEROLICO

		Air flow / Débit d'air / Luftmenge / Porta d'aria / Caudal de aire (m ³ /h)
Pulley close 0 round Poulie fermé 0 tour Riemenscheibe 0 Umdrehung geschlossen 0 giro di chiusura della puleggia 0 vueltas de cierre de la polea		
v : r.p.m - tr/min - UpM - giri/min. - r.p.m		
Pulley open X round Poulie ouverte X tour Riemenscheibe X Umdrehung öffnen X giri di chiusura della puleggia X vueltas de cierre de la polea		
v : r.p.m - tr/min - UpM - giri/min. - r.p.m		

APPENDIX / ANNEXE / ANLAGE / ALLEGATO / ANEXO

25 PE

		Air flow / Débit d'air / Luftmenge / Porta d'aria / Caudal de aire (m ³ /h)						
		1200	12500	13000	13500	14000	14500	15000
0	Pa	168	157	151	143	131	119	111
v = 762 tr/min	Kw	2.33	2.45	2.52	2.63	2.63	2.88	2.99
1	Pa	147	139	127	116	100	91	76
v = 724 tr/min	Kw	2.06	2.12	2.20	2.31	2.45	2.62	2.82
2	Pa	129	122	111	101	89	71	53
v = 689 tr/min	Kw	1.96	2.01	2.12	2.21	2.30	2.41	2.50
3	Pa	111	107	102	88	72	58	42
v = 654 tr/min	Kw	1.78	1.86	1.97	2.04	2.13	2.23	2.34
4	Pa	97	87	79	66	58	42	31
v = 628 tr/min	Kw	1.62	1.68	1.76	1.84	1.92	2.05	2.13

25 GE

		Air flow / Débit d'air / Luftmenge / Porta d'aria / Caudal de aire (m ³ /h)						
		1200	12500	13000	13500	14000	14500	15000
0	Pa	232	226	215	204	178	159	146
v = 897 tr/min	Kw	3.07	3.22	3.38	3.61	3.76	3.88	4.01
1	Pa	203	194	185	176	150	138	127
v = 862 tr/min	Kw	2.80	3.05	3.17	3.38	3.45	3.67	3.86
2	Pa	183	176	164	153	138	125	111
v = 820 tr/min	Kw	2.57	2.79	3.00	3.11	3.29	3.40	3.53
3	Pa	163	151	142	130	118	107	97
v = 783 tr/min	Kw	2.29	2.42	2.60	2.82	2.98	3.14	3.24
4	Pa	143	134	123	112	104	95	86
v = 759 tr/min	Kw	1.99	2.11	2.28	2.49	2.65	2.79	2.85

30 PE

		Air flow / Débit d'air / Luftmenge / Porta d'aria / Caudal de aire (m ³ /h)						
		12500	13000	13500	14000	14500	15000	15500
0	Pa	157	151	143	131	119	111	80
v = 762 tr/min	Kw	2.45	2.52	2.63	2.63	2.88	2.99	3.08
1	Pa	139	127	116	100	91	76	60
v = 724 tr/min	Kw	2.12	2.20	2.31	2.45	2.62	2.82	2.98
2	Pa	122	111	101	89	71	53	42
v = 689 tr/min	Kw	2.01	2.12	2.21	2.30	2.41	2.50	2.60
3	Pa	107	102	88	72	58	42	24
v = 654 tr/min	Kw	1.86	1.97	2.04	2.13	2.23	2.34	2.45
4	Pa	87	79	66	58	42	31	/
v = 628 tr/min	Kw	1.68	1.76	1.84	1.92	2.05	2.13	/

30 GE

		Air flow / Débit d'air / Luftmenge / Porta d'aria / Caudal de aire (m ³ /h)						
		12500	13000	13500	14000	14500	15000	15500
0	Pa	226	215	204	178	159	146	131
v = 897 tr/min	Kw	3.22	3.38	3.61	3.76	3.88	4.01	4.13
1	Pa	194	185	176	150	138	127	110
v = 862 tr/min	Kw	3.05	3.17	3.38	3.45	3.67	3.86	4.01
2	Pa	176	164	153	138	125	111	97
v = 820 tr/min	Kw	2.79	3.00	3.11	3.29	3.40	3.53	3.84
3	Pa	151	142	130	118	107	97	85
v = 783 tr/min	Kw	2.42	2.60	2.82	2.98	3.14	3.24	3.45
4	Pa	134	123	112	104	95	86	72
v = 759 tr/min	Kw	2.11	2.28	2.49	2.65	2.79	2.85	2.99

APPENDIX / ANNEXE / ANLAGE / ALLEGATO / ANEXO

35 PE

		Air flow / Débit d'air / Luftmenge / Porta d'aria / Caudal de aire (m ³ /h)					
		13000	13500	14000	14500	15000	15500
0	Pa	169	157	143	135	122	111
v = 762 tr/min	Kw	2.60	2.71	2.76	2.88	3.02	3.15
1	Pa	135	126	119	112	95	81
v = 724 tr/min	Kw	2.25	2.33	2.47	2.64	2.84	3.01
2	Pa	119	110	102	95	82	70
v = 689 tr/min	Kw	2.14	2.22	2.38	2.46	2.56	2.72
3	Pa	102	91	80	72	60	49
v = 654 tr/min	Kw	1.97	2.04	2.19	2.28	2.39	2.49
4	Pa	81	70	62	49	41	35
v = 628 tr/min	Kw	1.76	1.84	1.98	2.10	2.21	2.33

35 GE

		Air flow / Débit d'air / Luftmenge / Porta d'aria / Caudal de aire (m ³ /h)					
		13000	13500	14000	14500	15000	15500
0	Pa	227	216	193	174	161	146
v = 899 tr/min	Kw	3.49	3.72	3.88	3.96	4.09	4.22
1	Pa	197	188	162	150	139	122
v = 860 tr/min	Kw	3.29	3.49	3.58	3.88	3.97	4.11
2	Pa	176	165	151	138	124	109
v = 822 tr/min	Kw	3.11	3.23	3.40	3.52	3.63	3.95
3	Pa	154	142	130	119	109	97
v = 787 tr/min	Kw	2.71	2.93	3.08	3.24	3.35	3.56
4	Pa	135	124	116	107	98	84
v = 761 tr/min	Kw	2.39	2.58	2.76	2.91	2.95	3.09

40 PE

		Air flow / Débit d'air / Luftmenge / Porta d'aria / Caudal de aire (m ³ /h)					
		14000	14500	15000	15500	16000	16500
0	Pa	156	146	138	129	118	107
v = 762 tr/min	Kw	2.82	2.90	2.95	3.01	3.06	3.11
1	Pa	144	136	122	118	104	88
v = 724 tr/min	Kw	2.28	2.37	2.50	2.65	2.86	3.02
2	Pa	123	118	110	98	87	71
v = 689 tr/min	Kw	2.18	2.25	2.40	2.47	2.58	2.76
3	Pa	111	97	86	75	67	55
v = 654 tr/min	Kw	2.00	2.06	2.21	2.28	2.40	2.48
4	Pa	83	73	65	53	44	39
v = 628 tr/min	Kw	1.78	1.86	1.99	2.13	2.25	2.35

40 GE

		Air flow / Débit d'air / Luftmenge / Porta d'aria / Caudal de aire (m ³ /h)					
		14000	14500	15000	15500	16000	16500
0	Pa	224	213	191	173	159	145
v = 899 tr/min	Kw	3.49	3.73	3.88	3.97	4.10	4.25
1	Pa	195	186	160	149	138	121
v = 861 tr/min	Kw	3.30	3.49	3.59	3.87	3.97	4.11
2	Pa	174	164	149	137	125	110
v = 825 tr/min	Kw	3.11	3.22	3.40	3.53	3.63	3.94
3	Pa	150	141	129	120	109	95
v = 784 tr/min	Kw	2.71	2.93	3.10	3.24	3.33	3.57
4	Pa	135	123	113	105	97	83
v = 762 tr/min	Kw	2.40	2.61	2.79	2.92	2.96	3.09

APPENDIX / ANNEXE / ANLAGE / ALLEGATO / ANEXO

50 PE

		Air flow / Débit d'air / Luftmenge / Porta d'aria / Caudal de aire (m ³ /h)						
		17500	18000	18500	19000	19500	20000	21500
0	Pa	164	151	142	135	123	112	104
v = 820 tr/min	Kw	4.65	4.71	4.87	5.03	5.19	5.37	5.52
1	Pa	143	131	129	122	118	104	96
v = 788 tr/min	Kw	4.25	4.32	4.54	4.70	4.86	5.03	5.22
2	Pa	132	124	119	110	102	96	89
v = 746 tr/min	Kw	3.92	4.04	4.25	4.41	4.57	4.75	4.94
3	Pa	118	110	102	93	84	75	62
v = 703 tr/min	Kw	3.66	3.80	3.97	4.13	4.30	4.43	4.62
4	Pa	94	83	75	64	55	46	31
v = 665 tr/min	Kw	3.12	3.25	3.37	3.47	3.57	3.69	3.80

50 GE

		Air flow / Débit d'air / Luftmenge / Porta d'aria / Caudal de aire (m ³ /h)						
		17500	18000	18500	19000	19500	20000	21500
0	Pa	238	227	219	208	196	188	177
v = 1120 tr/min	Kw	6.55	6.74	6.88	7.02	7.18	7.30	7.55
1	Pa	221	211	202	179	167	153	145
v = 1078 tr/min	Kw	6.01	6.27	6.39	6.50	6.87	7.01	4.22
2	Pa	192	181	170	155	141	129	122
v = 1034 tr/min	Kw	5.20	5.49	5.60	5.88	6.31	6.69	6.90
3	Pa	167	155	146	132	120	110	101
v = 990 tr/min	Kw	4.59	4.86	5.11	5.39	5.82	6.10	6.32
4	Pa	140	135	127	118	105	97	90
v = 949 tr/min	Kw	4.48	4.70	4.73	4.87	5.02	5.34	5.60

60 PE

		Air flow / Débit d'air / Luftmenge / Porta d'aria / Caudal de aire (m ³ /h)						
		18000	18500	19000	19500	20000	20500	21000
0	Pa	164	151	142	135	123	112	104
v = 820 tr/min	Kw	4.65	4.71	4.87	5.03	5.19	5.37	5.52
1	Pa	143	131	129	122	118	104	96
v = 788 tr/min	Kw	4.25	4.32	4.54	4.70	4.86	5.03	5.22
2	Pa	132	124	119	110	102	96	89
v = 746 tr/min	Kw	3.92	4.04	4.25	4.41	4.57	4.75	4.94
3	Pa	118	110	102	93	84	75	62
v = 703 tr/min	Kw	3.66	3.80	3.97	4.13	4.30	4.43	4.62
4	Pa	94	83	75	64	55	46	31
v = 665 tr/min	Kw	3.12	3.25	3.37	3.47	3.57	3.69	3.80

60 GE

		Air flow / Débit d'air / Luftmenge / Porta d'aria / Caudal de aire (m ³ /h)						
		18000	18500	19000	19500	20000	20500	21000
0	Pa	238	227	219	208	196	188	177
v = 1120 tr/min	Kw	6.55	6.74	6.88	7.02	7.18	7.30	7.55
1	Pa	221	211	202	179	167	153	145
v = 1078 tr/min	Kw	6.01	6.27	6.39	6.50	6.87	7.01	4.22
2	Pa	192	181	170	155	141	129	122
v = 1034 tr/min	Kw	5.20	5.49	5.60	5.88	6.31	6.69	6.90
3	Pa	167	155	146	132	120	110	101
v = 990 tr/min	Kw	4.59	4.86	5.11	5.39	5.82	6.10	6.32
4	Pa	140	135	127	118	105	97	90
v = 949 tr/min	Kw	4.48	4.70	4.73	4.87	5.02	5.34	5.60

APPENDIX / ANNEXE / ANLAGE / ALLEGATO / ANEXO

70 PE		Air flow / Débit d'air / Luftmenge / Porta d'aria / Caudal de aire (m ³ /h)						
		24500	25000	25500	26000	26500	27000	27500
0	Pa	267	246	231	223	200	183	169
v = 765 tr/min	Kw	6.56	6.65	6.87	7.10	7.33	7.58	7.79
1	Pa	220	202	199	188	182	160	148
v = 725 tr/min	Kw	5.89	5.98	6.29	6.51	6.73	6.97	7.23
2	Pa	186	175	168	154	142	133	123
v = 675 tr/min	Kw	5.33	5.50	5.78	6.00	6.22	6.46	6.72
3	Pa	134	126	121	112	104	98	91
v = 640 tr/min	Kw	4.76	4.94	5.16	5.37	5.59	5.76	6.01
4	Pa	39	35	33	29	26	23	19
v = 600 tr/min	Kw	4.59	4.78	4.95	5.10	5.25	5.42	5.59

70 GE		Air flow / Débit d'air / Luftmenge / Porta d'aria / Caudal de aire (m ³ /h)						
		24500	25000	25500	26000	26500	27000	28000
0	Pa	486	447	421	400	364	332	308
v = 905 tr/min	Kw	9.06	9.18	9.49	9.80	10.11	10.46	10.75
1	Pa	425	390	384	363	351	309	286
v = 855 tr/min	Kw	7.41	7.54	7.92	8.20	8.48	8.78	9.11
2	Pa	360	338	325	300	278	262	243
v = 825 tr/min	Kw	6.75	6.95	7.31	7.59	7.87	8.18	8.50
3	Pa	310	289	268	244	220	197	163
v = 780 tr/min	Kw	6.29	6.53	6.83	7.10	7.39	7.62	7.94
4	Pa	243	220	203	180	160	142	117
v = 747 tr/min	Kw	5.57	5.81	6.02	6.20	6.38	6.59	6.79

80 PE		Air flow / Débit d'air / Luftmenge / Porta d'aria / Caudal de aire (m ³ /h)						
		25500	26000	26500	27000	27500	28000	28500
0	Pa	235	229	223	200	183	169	116
v = 765 tr/min	Kw	6.57	6.75	6.98	7.21	7.39	7.45	7.64
1	Pa	199	199	188	182	160	148	104
v = 725 tr/min	Kw	6.05	6.28	6.10	6.00	5.94	5.87	5.71
2	Pa	168	168	154	142	133	123	82
v = 675 tr/min	Kw	5.58	5.78	6.00	6.22	6.46	6.72	7.14
3	Pa	121	121	112	104	98	91	37
v = 640 tr/min	Kw	5.01	5.16	5.37	5.59	5.76	6.01	6.59
4	Pa	32	30	29	25	22	19	10
v = 600 tr/min	Kw	4.86	4.95	5.10	5.25	5.42	5.60	6.10

80 GE		Air flow / Débit d'air / Luftmenge / Porta d'aria / Caudal de aire (m ³ /h)						
		25500	26000	26500	27000	27500	28000	28500
0	Pa	451	434	421	400	364	332	308
v = 905 tr/min	Kw	9.06	9.18	9.49	9.80	10.11	10.46	10.75
1	Pa	425	390	384	363	351	309	286
v = 855 tr/min	Kw	7.41	7.54	7.92	8.20	8.48	8.78	9.11
2	Pa	360	338	325	300	278	262	243
v = 820 tr/min	Kw	6.75	6.95	7.31	7.59	7.87	8.18	8.50
3	Pa	310	289	268	244	220	197	163
v = 780 tr/min	Kw	6.29	6.53	6.83	7.10	7.39	7.62	7.94
4	Pa	243	220	203	180	160	142	117
v = 747 tr/min	Kw	5.57	5.81	6.02	6.20	6.38	6.59	6.79

REFRIGERANT CIRCUIT DIAGRAM

SCHEMA DU CIRCUIT FRIGORIFIQUE

KÄLTEKREISLAUFDIAGRAMM

SCHEMA DEL CIRCUITO REFRIGERANTE

ESQUEMA DEL CIRCUITO FRIGORIFICO

C1 : Compressor 1
C2 : Compressor 2
CPT : Condensing Pressure Tap
DF : Drier Filter
DL : Discharge Line
EPT : Evaporator Pressure Tap
EWTS : Entering Water Temperature Sensor
FPC : Condensation Pressure Transducer
FPE : Evaporator Pressure Transducer.
HPP : High Pressure Switch
HR : Evaporator Safety Heater
LPT : Liquid Pressure Tap
LT : Liquid Tank
LWTS : Leaving Water Temperature Sensor
M I : Moisture Indicator
CPE : Oil Level Equalization
PHE : Plate Heat Exchanger
SL : Suction Line
TEV : Thermodynamic Expansion Valve
V4V : 4 way valve

C1 : Compresseur 1
C2 : Compresseur 2
CPT : Prise de pression HP
DF : Filtre déshumidificateur
DL : ligne de refoulement des compresseurs
EPT : prise de pression BP
EWTS : Sonde de T° entrée d'eau
FPC : transducteur de pression HP
FPE : transducteur de pression BP
HPP : pressostat de sécurité HP
HR : Résistance chauffante de sécurité de l'échangeur à plaque
LPT : Prise de pression ligne liquide
LT : Bouteille de réserve
LWTS : Sonde de T° sortie d'eau
M I : voyant liquide
CPE : Egalisation de pression compresseur
PHE : Echangeur à plaques
SL : Ligne d'aspiration compresseurs
TEV : Détendeur thermostatique
V4V : Vanne d'inversion

C1 : Kompressor 1
C2 : Kompressor 2
CPT : Druckanschlussstelle Hochdruck
DF : Wasserabscheidungsfilter
DL : Druckleitung der Kompressoren
EPT : Druckanschlussstelle Niederdruck
EWTS : Messfühler Wassereintritt
FPC : Hochdruck - Messwandler
FPE : Niederdruck - Messwandler
HPP : Sicherheitspressostat Hochdruck
HR : Sicherheitsheizwiderstand des Plattenwärmetauschers
LPT : Druckanschlussstelle Flüssigkeitsleitung
LT : Flasche mit Flüssigkeitsreserve
LWTS : Temperaturmessfühler Wasseraustritt
M I : Flüssigkeitsschauglas
CPE : Ausgleich Kompressorndruck
PHE : Plattenwärmetauscher
SL : Saugleitung Kompressor
TEV : Thermostatisches Druckminderventil
V4V : Umkehrventil

C1 : Compressore 1
C2 : Compressore 2
CPT : Presa di pressione HP
DF : Filtro disidratatore
DL : linea di mandata dei compressori
EPT : Presa di pressione BP
EWTS : Sonda di T° ingresso d'acqua
FPC : trasduttore di pressione HP
FPE : trasduttore di pressione BP
HPP : pressostato di sicurezza HP
HR : Resistenza riscaldante di sicurezza dello scambiatore a piastre
LPT : Presa di pressione liquido
LT : Bombola di riserva
LWTS : Sonda di T° uscita d'acqua
M I : spia liquido
CPE : Equalizzazione di pressione compressore
PHE : Scambiatore a piastre
SL : Linea di aspirazione compressore
TEV : Regolatore di pressione termostatico
V4V : Valvola di inversione

C1 : Compressor 1
C2 : Compressor 2
CPT : Toma de presión AP
DF : Filtro deshumidificador
DL : Línea de descarga de los compresores
EPT : Toma de presión BP
EWTS : Sonda de temperatura de entrada de agua
FPC : transductor de presión AP
FPE : transductor de presión BP
HPP : presostato de seguridad AP
HR : Resistencia calentadora de seguridad del intercambiador de placa
LPT : Toma de presión línea líquido
LT : Botella de reserva
LWTS : Sonda de temperatura salida de agua
M I : indicador luminoso líquido
OLE : Igualación de presión del compresor
PHE : Intercambiador de placas
SL : Línea de aspiración del compresor
SL : Línea de aspiración del compresor
TEV : Reductor de presión termostático
V4V : Válvula de inversión

AQCL

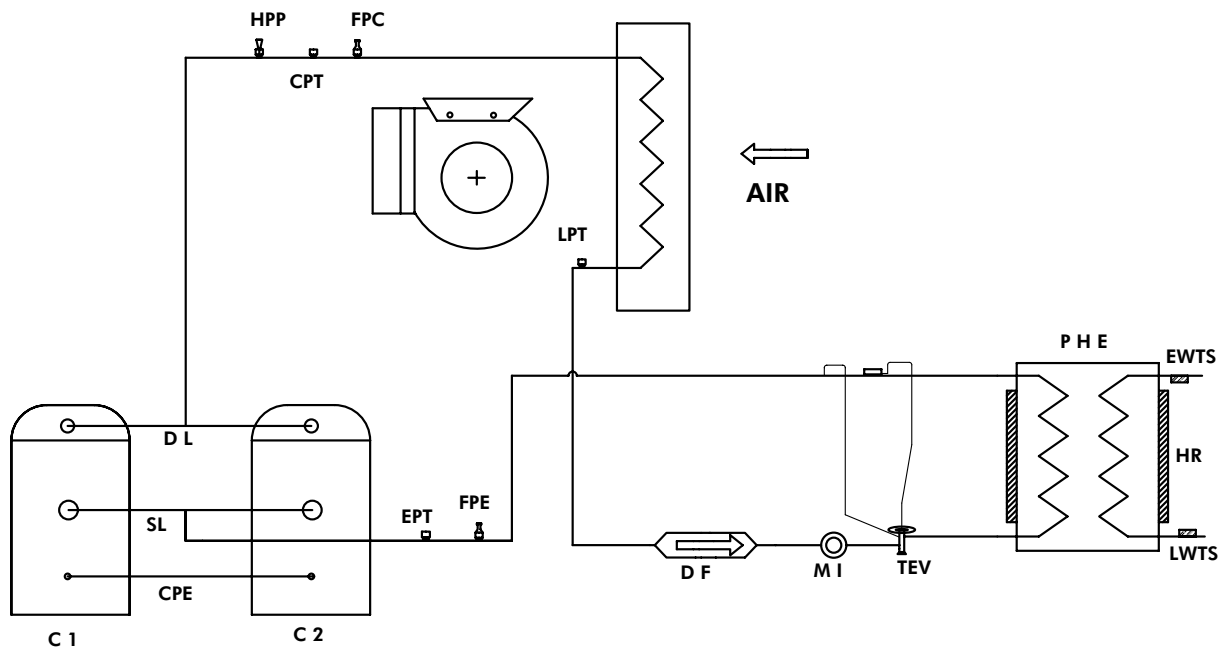

AQCH

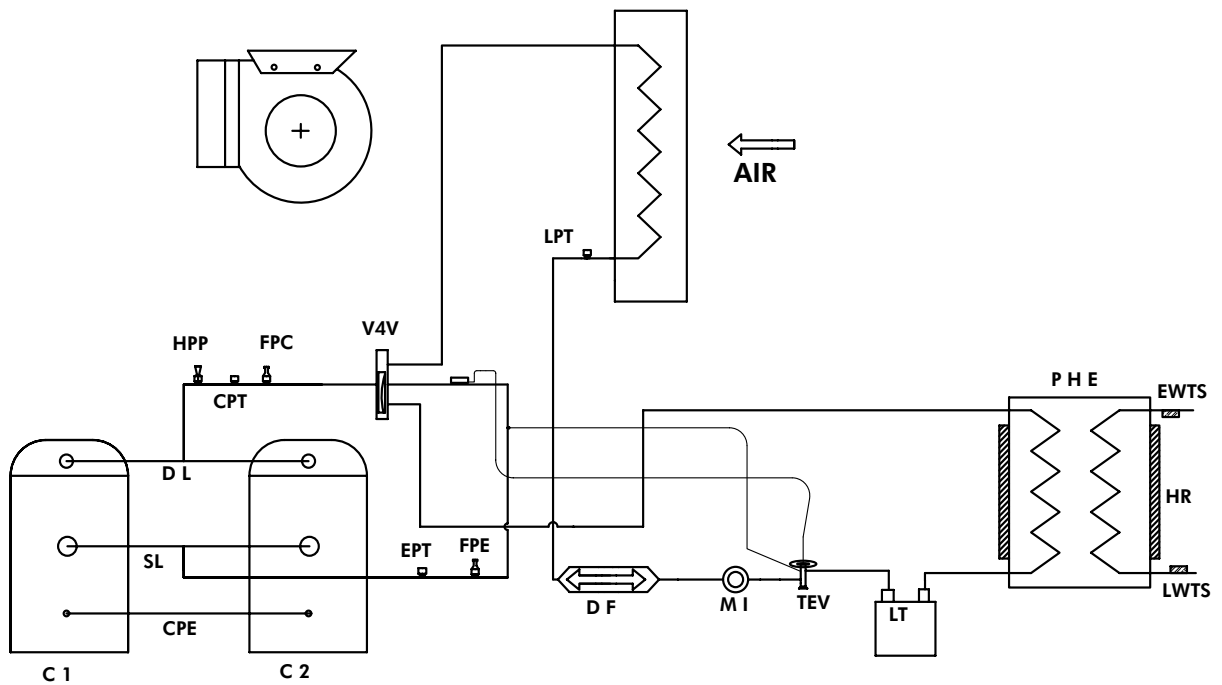

APPENDIX / ANNEXE / ANLAGE / ALLEGATO / ANEXO

HYDRAULIC CIRCUIT DIAGRAM

SCHEMA DU CIRCUIT HYDRAULIQUE

HYDRAULISCHER SCHALTPLAN

SCHEMA CIRCUITALE IDRAULICO

ESQUEMA CIRCULAR HIDRÁULICO

AP	: Automatic air purge valve
CV	: Cut off valve
DP	: Differential Pressure sensor (only 25/30/35 models)
DU	: Drain off valve
EAV	: Manual adjustment valve
ET	: Expansion Tank
EWC	: Entering water connection
EWTS	: Entering Water Temperature Sensor
FC	: Flexible joint
FS	: Flow Switch (only 40/50/60/70/80 models)
HR	: Evaporator Safety Heater
LWC	: Leaving water connection
LWTS	: Leaving Water Temperature Sensor
PHE	: Plate Heat Exchanger
PT	: Temperature sensor
PU	: Water pump
SF	: Screen Filter (supplied not assembled for 25/30/35)
SV	: Safety Valve
WPG	: Water pressure tap

AP	: purge d'air automatique
CV	: vanne d'isolement
DP	: Capteur de pression différentielle (mod. 25/30/35)
DU	: Robinet d'eau
EAV	: prise de pression d'eau
ET	: Vase d'expansion
EWC	: entrée d'eau
EWTS	: Sonde de T° entrée d'eau
FC	: liaison souple
FS	: Contrôleur de débit (modèles 40/50/60/70/80)
HR	: Résistance chauffante de sécurité de l'échangeur à plaque
LWC	: Sortie d'eau
LWTS	: Sonde de T° sortie d'eau
PHE	: Echangeur à plaque
PT	: sonde de T°
PU	: Pompe à eau
SF	: filtre à eau (livré non monté sur mod. 25/30/35)
SV	: Soupape de sécurité
WPG	: prise de pression d'eau

AP	: Automatische Entlüftung
CV	: Absperrschieber
DP	: Differentialdrucksensor (Mod. 25/30/35)
DU	: Wasserhahn
EAV	: Wasserdruckanschlussstelle
ET	: Ausdehnungsgefäß
EWC	: Wassereintritt
EWTS	: Temperaturmessfühler Wassereintritt
FC	: Flexible Verbindungsleitung
FS	: Durchflusswächter (Modelle 40/50/60/70/80)
HR	: Sicherheitsheizwiderstand des Plattenwärmetauschers
LWC	: Wasseraustritt
LWTS	: Temperaturmessfühler Wasseraustritt
PHE	: Plattenwärmetauscher
PT	: Temperaturmessfühler
PU	: Wasserpumpe
SF	: Wasserfilter (bei Mod. 25/30/35 nicht montiert geliefert)
SV	: Sicherheitsventil
WPG	: Wasserdruckanschlussstelle

AP	: Spurgo di aria automatico
CV	: valvola di isolamento
DP	: sensore di pressione differenziale (mod. 25/30/35)
DU	: Rubinetto d'acqua
EAV	: presa di pressione dell'acqua
ET	: Vasca di espansione
EWC	: ingresso d'acqua
EWTS	: sonda di T° di ingresso d'acqua
FC	: collegamento flessibile
FS	: Controllore di portata (modelli 40/50/60/70/80)
HR	: Resistenza riscaldante di sicurezza dello scambiatore a piastre
LWC	: Uscita d'acqua
LWTS	: sonda di T° di uscita d'acqua
PHE	: Scambiatore a piastre
PT	: sonda di T°
PU	: Pompa ad acqua
SF	: filtro ad acqua (fornito non montato su mod. 25/30/35)
SV	: Valvola di sicurezza
WPG	: presa di pressione dell'acqua

AP	: purga de aire automática
CV	: válvula de aislamiento
DP	: Sensor de presión diferencial (mod. 25/30/35)
DU	: Llave de agua
EAV	: toma de presión de agua
ET	: Vaso de expansión
EWC	: entrada de agua
EWTS	: sonda de temperatura de entrada de agua
FC	: canalización flexible
FS	: Controlador de caudal (modelos 40/50/60/70/80)
HR	: Resistencia calentadora de seguridad del intercambiador de placa
LWC	: Salida de agua
LWTS	: sonda de temperatura de salida de agua
PHE	: Intercambiador de placa
PT	: sonda de temperatura
PU	: Bomba de agua
SF	: filtro de agua (entregado no montado en mod. 25/30/35)
SV	: Válvula de seguridad
WPG	: toma de presión de agua

BASIC

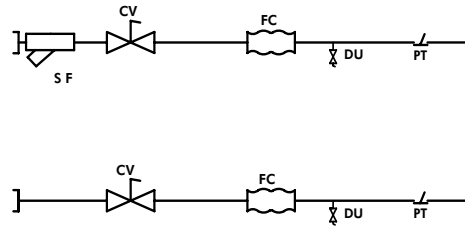
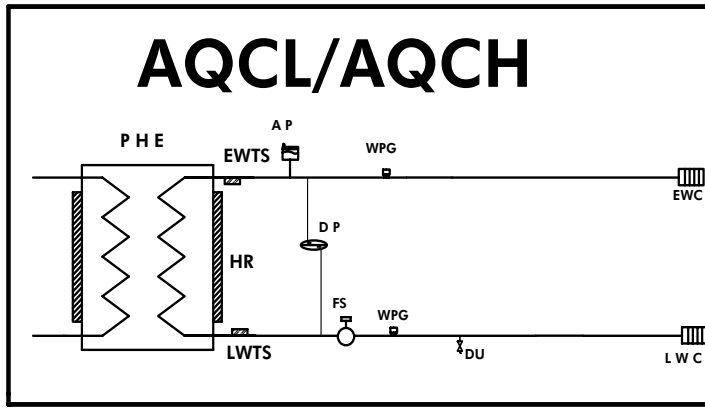

PACK

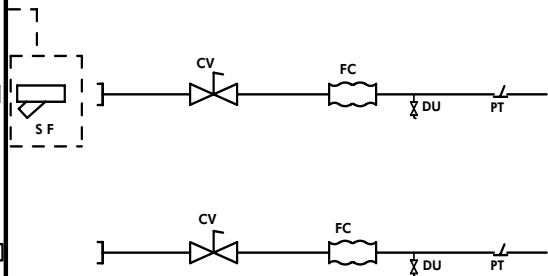
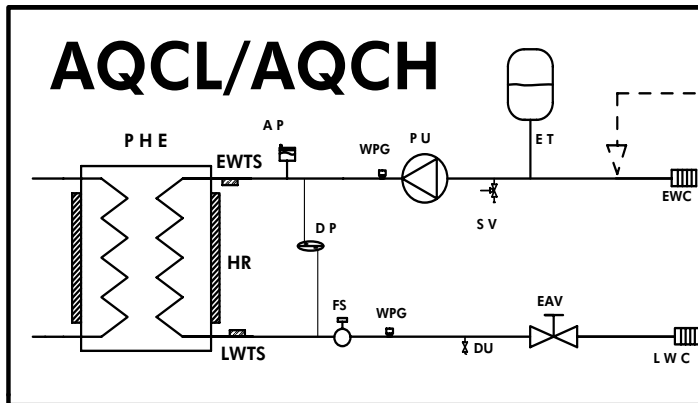

MINIMUM VOLUME FOR COMFORT AIR CONDITIONING APPLICATION

VOLUME MINIMUM POUR APPLICATION CLIMATISATION DE CONFORT

MINDESTVOLUMEN FÜR KOMFORTANWENDUNGEN DER KLIMATECHNIK

VOLUME MINIMO PER APPLICAZIONE CLIMATIZZAZIONE DI CONFORT

VOLUMEN MÍNIMO PARA APLICAR LA CLIMATIZACIÓN DE CONFORT

		25	30	40	50	60	70	80
Volume*	l	65	75	105	120	145	170	200
Volumen*								

(*) Volumes calculate at Eurovent operating conditions (air: 35°C, water: 12/7 °C) with a ratio of 2.5 l/kW. For other nominal operating conditions, recalculate the minimum volume by multiplying the corresponding cooling capacity by the ratio of 2.5 l/kW.

If the minimum volume cannot be met, an additional buffer tank should be included in the installation.

(*) Volumes calculés aux conditions de fonctionnement Eurovent (air : 35°C, eau : 12/7 °C) avec ratio de 2,5 l/kW. Pour d'autres conditions nominales d'utilisation, recalculer le volume minimum en multipliant la puissance frigorifique correspondante par le ratio 2,5 l/kW.

Si le volume minimum ne peut pas être respecté, un ballon tampon additionnel devra être ajouté dans l'installation.

(*) Volumen bei Betriebsbedingungen Eurovent (Luft: 35°C, Wasser: 12/7 °C) mit einer Verhältniszahl von 2,5 l/kW errechnet. Bei anderen Nennbetriebsbedingungen das Mindestvolumen durch Multiplizieren der entsprechenden Kühlleistung mit der Verhältniszahl 2,5 l/kW neu errechnen.

Wenn das Mindestvolumen nicht eingehalten werden kann, muss ein zusätzlicher Pufferspeicher in der Anlage hinzugefügt werden.

(*) Volumi calcolati alle condizioni di funzionamento Eurovent (aria: 35°C, acqua: 12/7 °C) con ratio di 2,5 l/kW. Per altre condizioni nominali d'uso, ricalcolare il volume minimo moltiplicando la potenza frigorifera corrispondente dal ratio 2,5 l/kW.

Se il volume minimo non può essere rispettato, un pallone tampone addizionale dovrà essere aggiunto nell'installazione.

(*) Volúmenes calculados según las condiciones de funcionamiento Eurovent (aire: 35°C, agua: 12/7°C) con un ratio de 2,5 l/kW. Para otras condiciones nominales de utilización, volver a calcular el volumen mínimo multiplicando la potencia frigorífica correspondiente por el ratio de 2,5 l/kW.

Si no se puede respetar el volumen mínimo, se tendrá que añadir a la instalación un depósito acumulador intermedio adicional.

APPENDIX / ANNEXE / ANLAGE / ALLEGATO / ANEXO

MAXIMUM (*) VOLUME IN LITRES FOR A COMFORT AIR CONDITIONING APPLICATION
VOLUME MAXIMUM (*) EN LITRES POUR APPLICATION CLIMATISATION DE CONFORT
HÖCHSTVOLUMEN (*) IN LITER FÜR KOMFORTANWENDUNG DER KLIMATECHNIK
VOLUME MAX. (*) IN LITRI PER APPLICAZIONE CLIMATIZZAZIONE DI CONFORT
VOLUMEN MÁXIMO (*) EN LITROS PARA APLICAR LA CLIMATIZACIÓN DE CONFORT.

		20 - 30	40 -50 - 60	70 - 80
Water / Eau / Wasser Acqua / Agua		300	600	600
Glycol solution Solution de glycol Glykollösung Soluzione di glicol Solución de glicol	10%	225	450	450
	15%	215	425	425
	20%	200	400	400
	25%	185	375	375
	30%	175	350	350
	35% max	150	300	300

(*) Limitation linked to the volume of the expansion tank in the unit. In the case of an installation with a water volume higher than the values stated in the above table, an additional buffer tank should be included in the installation.

(*) Limitation liée au volume du vase d'expansion dans l'unité. Dans le cas d'une installation avec un volume d'eau supérieur aux valeurs annoncées dans le tableau ci-dessus, incorporer un vase d'expansion additionnel dans l'installation.

(*) Beschränkung wegen dem Volumen des Ausdehnungsgefäßes in der Einheit. Bei einer Anlage mit einem größeren Wasservolumen als in der oben stehenden Tabelle angegeben muss ein zusätzliches Ausdehnungsgefäß in der Anlage hinzugefügt werden.

(*) Limitazione legata al volume della vasca di espansione nell'unità. In caso di unità con un volume di acqua superiore ai valori riportati nella tabella di cui sopra, incorporare una vasca di espansione addizionale nell'installazione.

(*) Limitación vinculada al volumen del vaso de expansión en la unidad. En caso de una instalación con un volumen de agua superior a los valores anunciados en el cuadro anteriormente indicado, incorporar un vaso de expansión adicional a la instalación.

WATER FLOW DETECTOR FOR MODELS 25-30-35

DETECTEUR DE DEBIT D'EAU POUR MODELES 25-30-35

WASSERMENGENMESSFÜHLER FÜR MODELLE 25-30-35

RILEVATORE DI PORTATA DELL'ACQUA PER MODELLI 25-30-35

DETECTOR DE CAUDAL DE AGUA PARA LOS MODELOS 25-30-35

WATER FLOW DETECTOR
DETECTEUR DE DEBIT D'EAU
WASSERMENGENMESSFÜHLER
RILEVATORE DI PORTATA DELL'ACQUA
DETECTOR DE CAUDAL DE AGUA

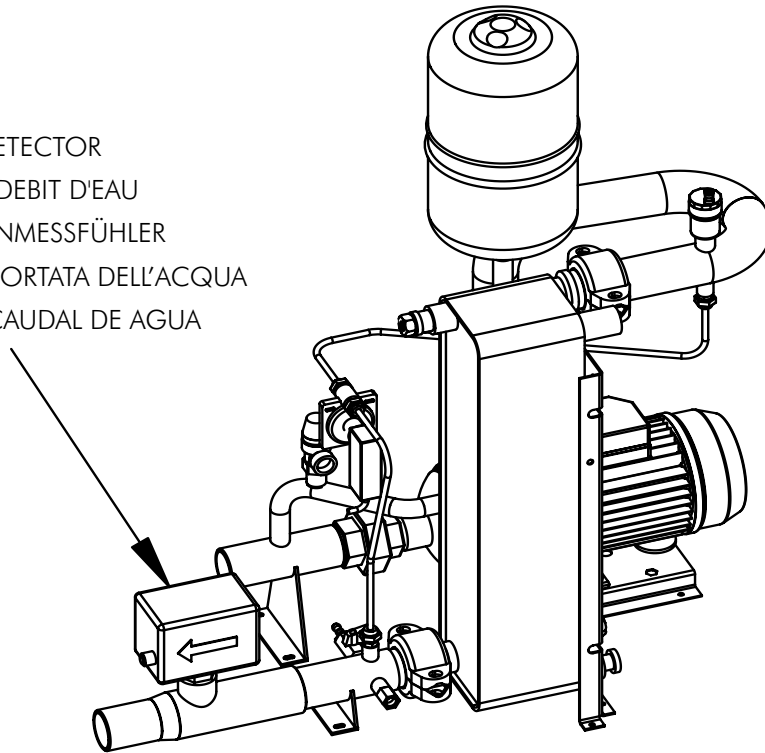

(*) Limitation liée au volume du vase d'expansion dans l'unité. Dans le cas d'une installation avec un volume d'eau supérieur aux valeurs annoncées dans le tableau ci-dessus, incorporer un vase d'expansion additionnel dans l'installation.

WATER FLOW DETECTOR
DETECTEUR DE DEBIT D'EAU
WASSERMENGENMESSFÜHLER
RILEVATORE DI PORTATA
DELL'ACQUA
DETECTOR DE CAUDAL DE AGUA

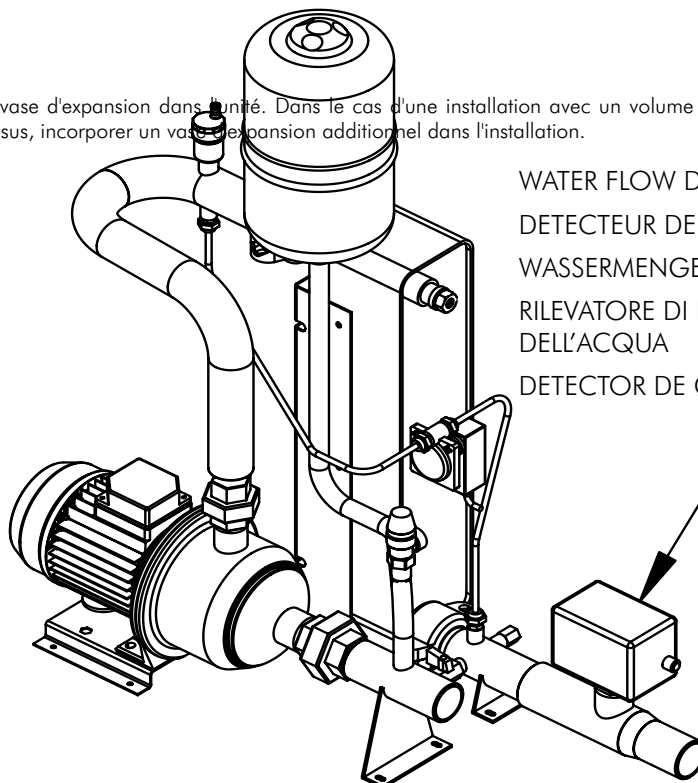

**HYDRAULIC CHARACTERISTICS
CARACTÉRISTIQUES HYDRAULIQUES
HYDRAULISCHE DATEN
CARATTERISTICHE IDRAULICHE
CARACTERÍSTICAS HIDRÁULICAS**

**AVAILABLE PRESSURE
PRESSION DISPONIBLE
VERFÜGBARER DRUCK
PRESSIONE DISPONIBILE
PRESIÓN DISPONIBLE**

Water flow Débit d'eau Wasserzufluß Flusso d'acqua Caudal de agua (l/s)		
Nominal (1)		
Mini (2)		
Maxi (3)		

1) Eurovent conditions: Water: 12 / 7 °C, Air: 35 °C.

(2) With water Dt: 7.5 K on nominal capacity.

(3) With water Dt: 3 K on nominal capacity.

(1) Conditions Eurovent, eau : 12 / 7 °C, air : 35 °C.

(2) Avec Dt eau : 7,5 K sur la puissance nominale.

(3) Avec Dt eau : 3 K sur la puissance nominale.

(1) Bedingungen Eurovent, Wasser: 12 / 7 °C, Luft: 35 °C.

(2) Bei Dt Wasser: 7,5 K der Nennleistung.

(3) Bei Dt Wasser: 3 K der Nennleistung.

(1) Condizioni Eurovent, acqua: 12 / 7 °C, aria: 35 °C.

(2) Con portata acqua: 7,5 K sulla potenza nominale.

(3) Con portata acqua: 3 K sulla potenza nominale

(1) Condiciones Eurovent, agua: 12/7°C, aire: 35°C.

(2) Con Dt agua: 7,5 K sobre la potencia nominal.

(3) Con Dt agua: 3 K sobre la potencia nominal.

AQCL

25 - 30

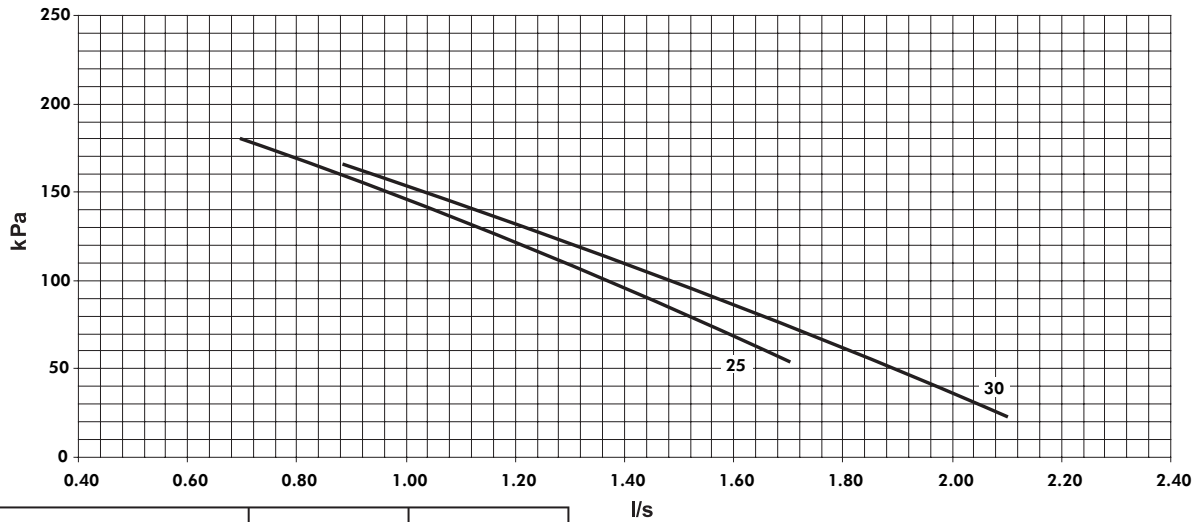

Water flow Débit d'eau Wasserzufluß Flusso d'acqua Caudal de agua (l/s)	25	30
Nominal (1)	1.04	1.29
Mini (2)	0.7	0.86
Maxi (3)	1.73	2.15

35 - 40 - 50 - 60 - 70 - 80

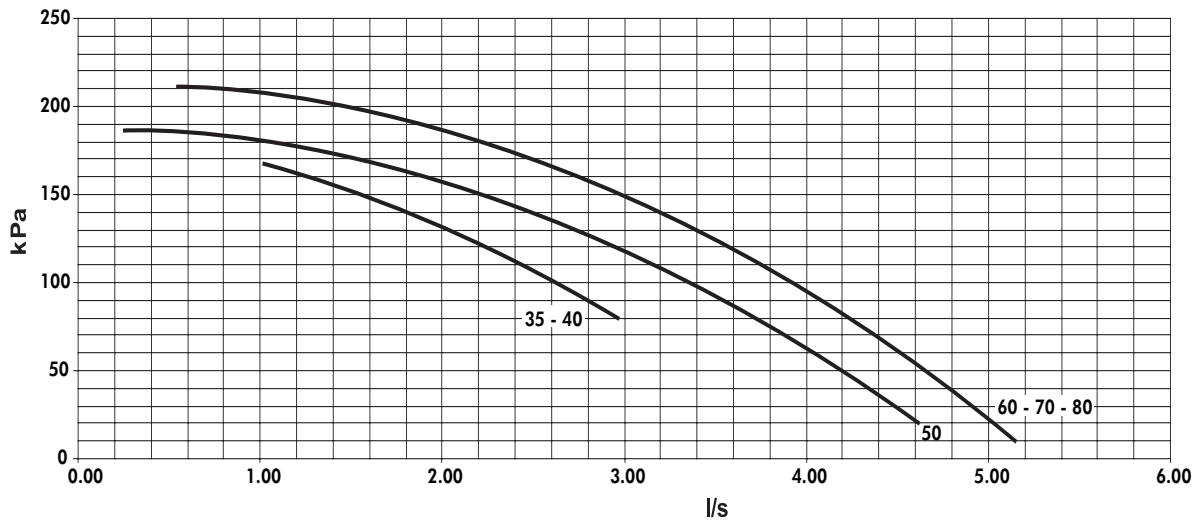

Water flow Débit d'eau Wasserzufluß Flusso d'acqua Caudal de agua (l/s)	35	40	50	60	70	80
Nominal (1)	1.6	1.75	2.16	2.75	3.08	3.2
Mini (2)	1.07	1.16	1.45	1.8	2.1	2.3
Maxi (3)	2.68	2.92	3.58	4.56	5.09	5.3

AQCH

25 - 30

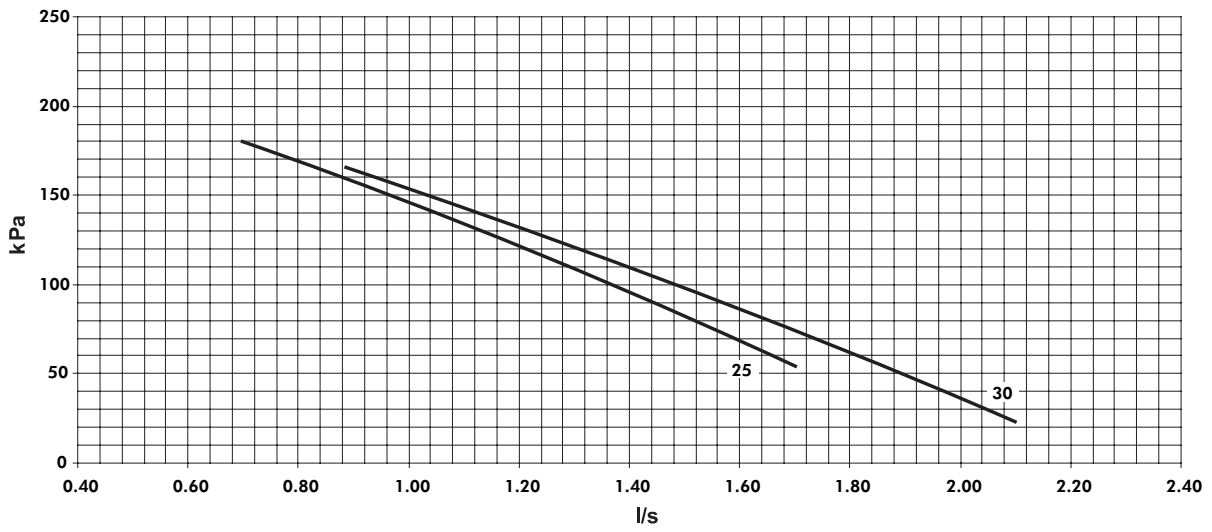

35 - 40 - 50 - 60 - 70 - 80

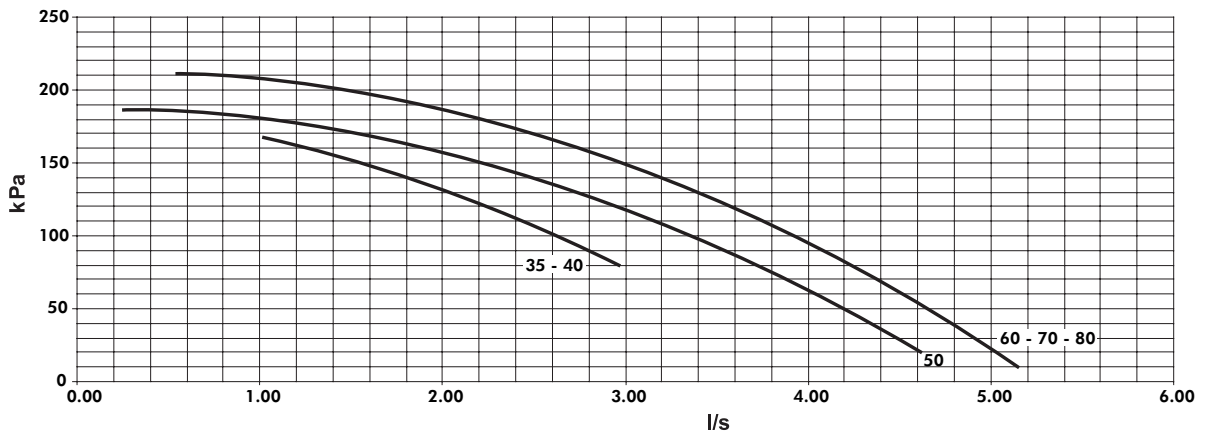

HEAT EXCHANGER WATER PRESSURE LOSSES

PERTE DE CHARGE SUR L'EAU DES ECHANGEURS DE CHALEUR

DRUCKVERLUST IM WASSER DER WÄRMETAUSCHER

PERDITA DI CARICO SULL'ACQUA DEGLI SCAMBIATORI DI CALORE

PÉRDIDA DE CARGA EN EL AGUA DE LOS INTERCAMBIADORES DE CALOR

25 - 30 - 35

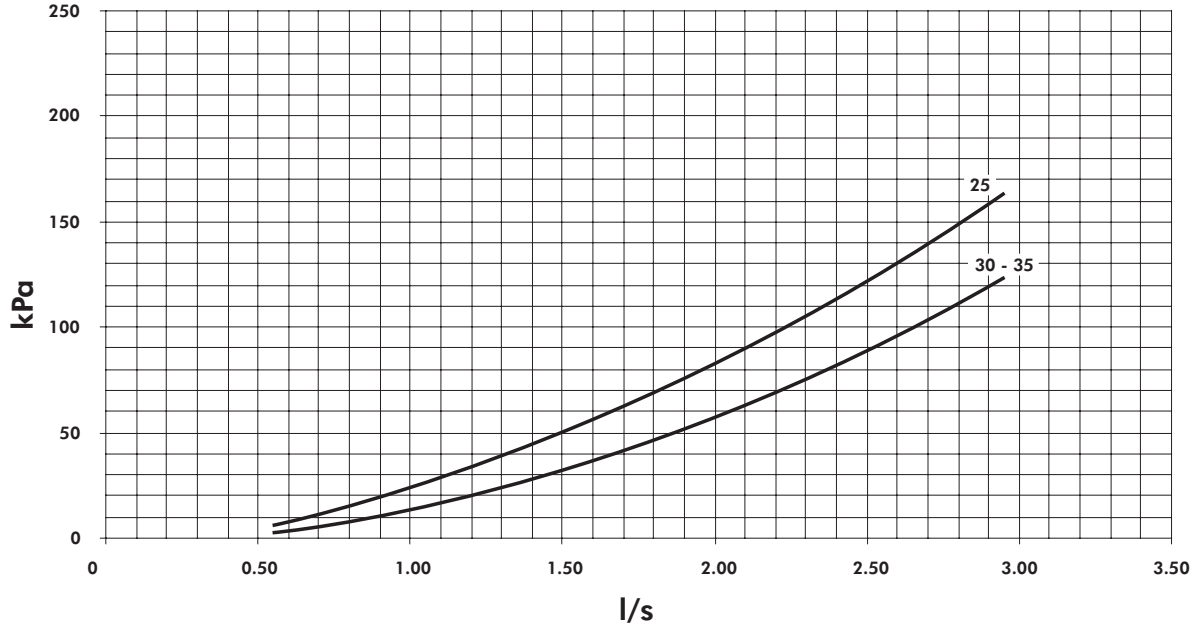

40 - 50 - 60 - 70 - 80

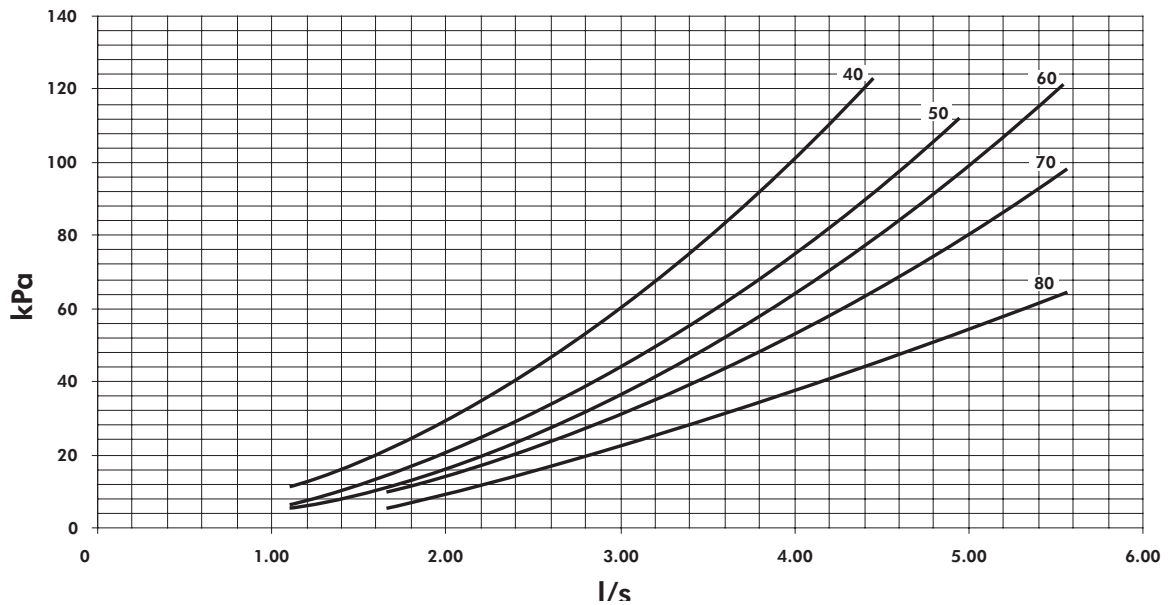

Water temperatur: 10°C

Température d'eau: 10°C

Wassertemperatur: 10°C

temperatura d'acqua: 10°C

temperatura de agua: 10°C

EC Compliance declaration

Under our own responsibility, we declare that the product designated in this manual comply with the provisions of the EEC directives listed hereafter and with the national legislation into which these directives have been transposed.

Déclaration CE de conformité

Nous déclarons sous notre responsabilité que les produits désignés dans la présente notice sont conformes aux dispositions des directives CEE énoncées ci- après et aux législations nationales les transposant.

EG-Konformitätserklärung

Wir erklären in eigener Verantwortung, das die in der vorliegenden Beschreibung angegebenen Produkte den Bestimmungen der nachstehend erwähnten EG-Richtlinien und den nationalen Gesetzesvorschriften entsprechen, in denen diese Richtlinien umgesetzt sind.

Dichiarazione CE di conformità

Dichiariamo, assumendone la responsabilità, che i prodotti descritti nel presente manuale sono conformi alle disposizioni delle direttive CEE di cui sott e alle legislazioni nazionali che li recepiscono

Declaración CE de conformidad

Declaramos, bajo nuestra responsabilidad, que los productos designados en este manual son conformes a las disposiciones de las directivas CEE enunciadas a continuación, así como a las legislaciones nacionales que las contemplan.

AQCL 25 / 30 / 35 / 40 / 50 / 60 / 70 / 80
AQCH 25 / 30 / 35 / 40 / 50 / 60 / 70 / 80

MACHINERY DIRECTIVE 98 / 37 / EEC
LOW VOLTAGE DIRECTIVE (DBT) 73 / 23 / CEE AMENDED BY DIRECTIVE 93 / 68 EEC
ELECTROMAGNETIC COMPATIBILITY DIRECTIVE 89 / 336 / EEC
PRESSURISE EQUIPMENT DIRECTIVE (DESP) 97 / 23 / EEC
MODULE A CATEGORY I : AQCL 25/30/35 - AQCH 25/30/35
SUB-MODULE A1 CATEGORY II : AQCL 40/50/60/70/80 - AQCH 40/50/60/70/80
NOTIFIED BODY: TÜV RHEINLAND – 6, RUE HALÉVY – 75 009 PARIS - FRANCE.

DIRECTIVE MACHINES 98 / 37 C.E.E.
DIRECTIVE BASSE TENSION (DBT) 73 / 23 C.E.E. , AMENDEE PAR DIRECTIVE 93 / 68 C.E.E.
DIRECTIVE COMPATIBILITE ELECTROMAGNETIQUE 89 / 336 / C.E.E.
DIRECTIVE DES EQUIPEMENTS SOUS PRESSION (DESP) 97 / 23 C.E.E.
MODULE A CATEGORIE I : AQCL 25/30/35 - AQCH 25/30/35
SOUS-MODULE A1 CATEGORIE II : AQCL 40/50/60/70/80 - AQCH 40/50/60/70/80
AVEC SURVEILLANCE PAR LE TUV RHEINLAND 6, RUE HALÉVY – 75 009 PARIS - FRANCE.

RICHTLINIE MASCHINEN 98 / 37 / EG
RICHTLINIE NIEDERSpannung (DBT) 73 / 23 / EG ABGEÄNDERT DURCH DIE RICHTLINIE 93 / 68 EG
RICHTLINIE ELEKTROMAGNETISCHE VERTRÄGLICHKEIT 89 / 336 / EG
RICHTLINIE FÜR AUSTRÜSTUNGEN UNTER DRUCK (DESP) 97 / 23 / EG
MODUL A, KATEGORIE I : AQCL 25/30/35 - AQCH 25/30/35
UNTER MODUL A1, KATEGORIE II : AQCL 40/50/60/70/80 - AQCH 40/50/60/70/80
MIT KONTROLLE DURCH DEN TUV RHEINLAND 6, RUE HALÉVY – 75 009 PARIS - FRANCE.

DIRETTIVA MACHINE 98 / 37 / CEE
DIRETTIVA BASSA TENSIONE (DBT) 73 / 23 / CEE EMENDATA DALLA DIRETTIVA 93 / 68 CEE
DIRETTIVA COMPATIBILITA ELETTROMAGNATICA 89 / 336 / CEE
DIRETTIVA DEGLI IMPIANTI SOTTO PRESSIONE (DESP) 97 / 23 / CEE
MODULO A, CATEGORIA I : AQCL 25/30/35 - AQCH 25/30/35
SOTTOMODULO A1, CATEGORIA II : AQCL 40/50/60/70/80 - AQCH 40/50/60/70/80
CON SUPERVISION POR EL TUV RHEINLAND 6, RUE HALÉVY – 75 009 PARIS - FRANCE.

DIRETTIVA MAQUIAS 98 / 37 / CEE
DIRECTIVA BAJA TENSION (DBT) 73 / 23 / CEE ENMENDATA POR LA DIRECTIVA 93/ 68 CEE
DIRECTIVA COMPATIBILIDAD ELECTROMAGNETICA 89 / 336 / CEE
DIRECTIVA DE LOS EQUIPOS A PRESION (DESP) 97 / 23 / CEE
MODULO A, CATEGORIA I : AQCL 25/30/35 - AQCH 25/30/35
BAJA MODULO A1, CATEGORIA II : AQCL 40/50/60/70/80 - AQCH 40/50/60/70/80
CON SORVEGLIANZA DAL TUV RHEINLAND 6, RUE HALÉVY – 75 009 PARIS - FRANCE.

And that the following paragraphs of the harmonised standards have been applied.
Et que les paragraphes suivants les normes harmonisées ont été appliqués.
Und dass die folgenden Paragraphen der vereinheitlichten Normen Angewandt wurden.
E che sono stati applicati i seguenti paragrafi delle norme armonizzate.

EN 60 204
EN 60 335-2-40
EN 50 082
EN 814

EN 60 204-1
EN 61 000-3-2
EN 55 011
EN 378

EN 60 335-1
EN 55 022
EN 255
EN 14511

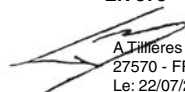
A Tillières Sur Avre
27570 - FRANCE
Le: 22/07/2004
Franck Bailly
Quality Manager
ACE Industrie

Wesper S.A.S.

42, cours Jean-Jaurès
17800 PONS - FRANCE

Tél. : +33-5 46 92 33 33

Fax : +33-5 46 91 38 33

www.wesper.com

As part of our ongoing product improvement programme, our products are subject to change without prior notice. Non contractual photos.

Dans un souci d'amélioration constante, nos produits peuvent être modifiés sans préavis. Photos non contractuelles.

