

VAILLANT SPARE PART CATALOGUE

TURBOmax boilers

VU 182 E, 242 E, 282 E

TURBOmax combination boilers

TURBOmax VUW 242 E, 282 E

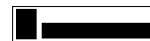

8026 74 GB 09/96

View of appliances

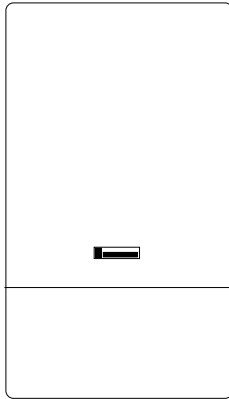

VU 182, 242, 282 E
VUW 242, 282 E

Content

	Page
General view sheets	3 - 4
Main component 01	
Diverter section	5 - 7
Main component 04	
Burner	9 - 11
Main component 05	
Gas section	13 - 15
Main component 06	
Heat exchanger	17 - 19
Main component 07	
Casing parts, Combustion chamber, Flue fan	21 - 25
Main component 08	
Connection parts, Pump, Expansion vessel	27 - 31
Main component 12	
Switch box	33 - 37

General view sheets

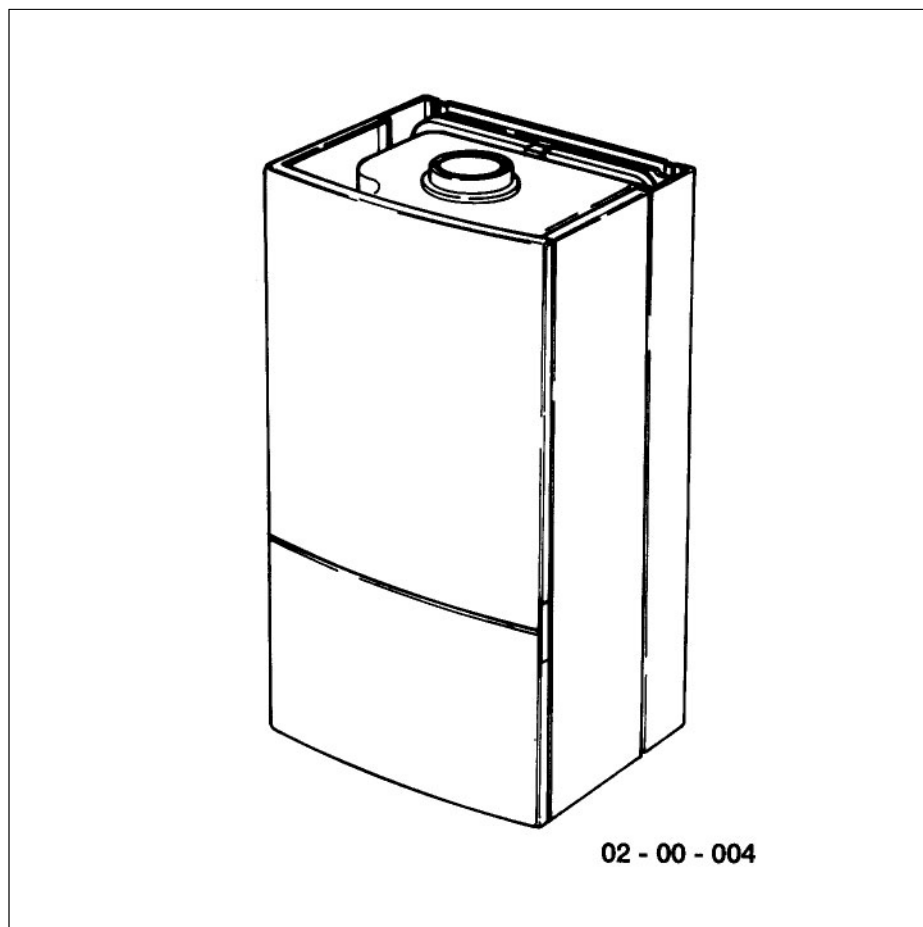

VU 182,242,282 E, VUW 242,282 E

Page

4

General view sheets
VU 182,242,282 E, VUW 242,282 E

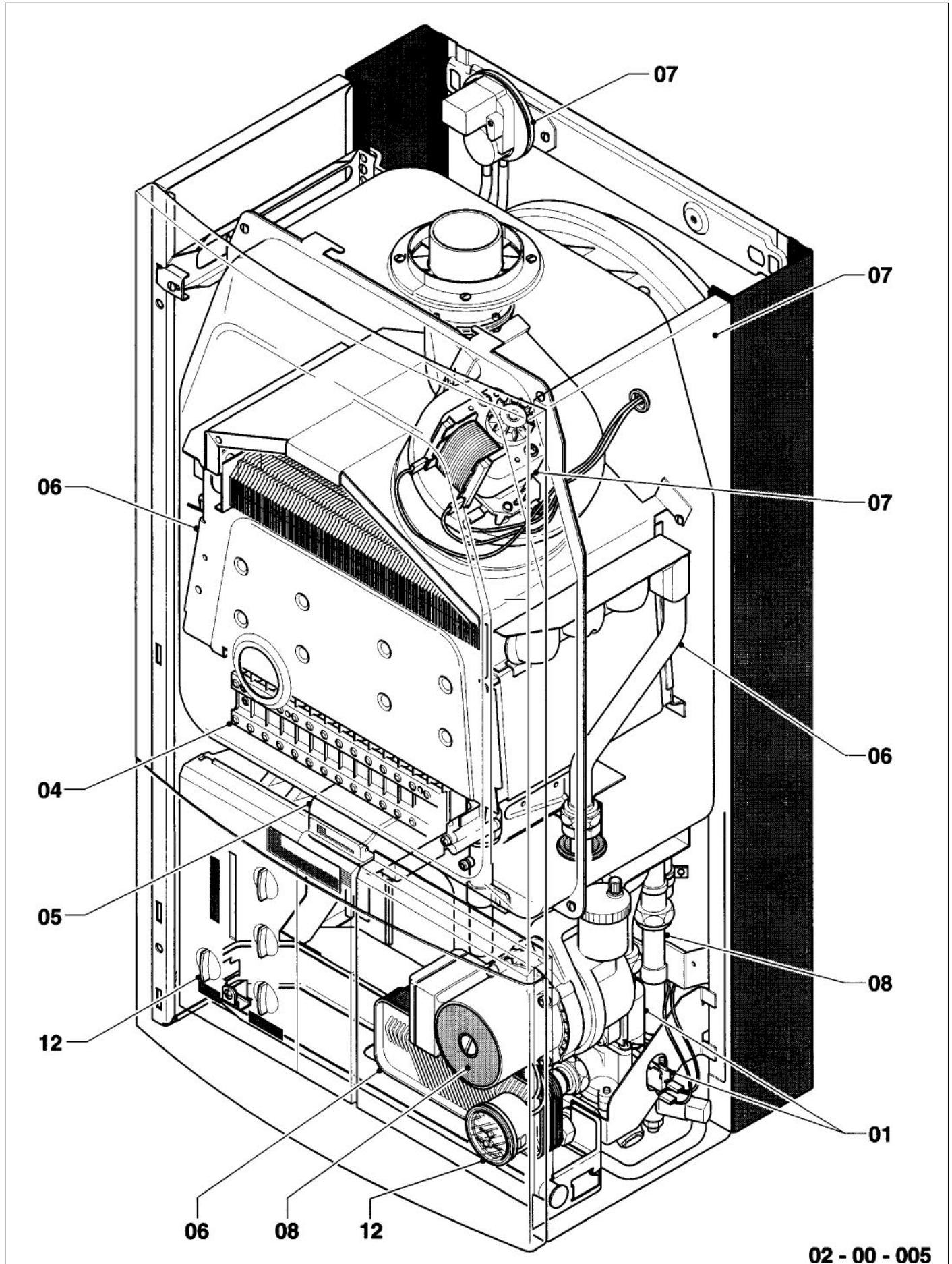

02 - 00 - 005

Main component 01

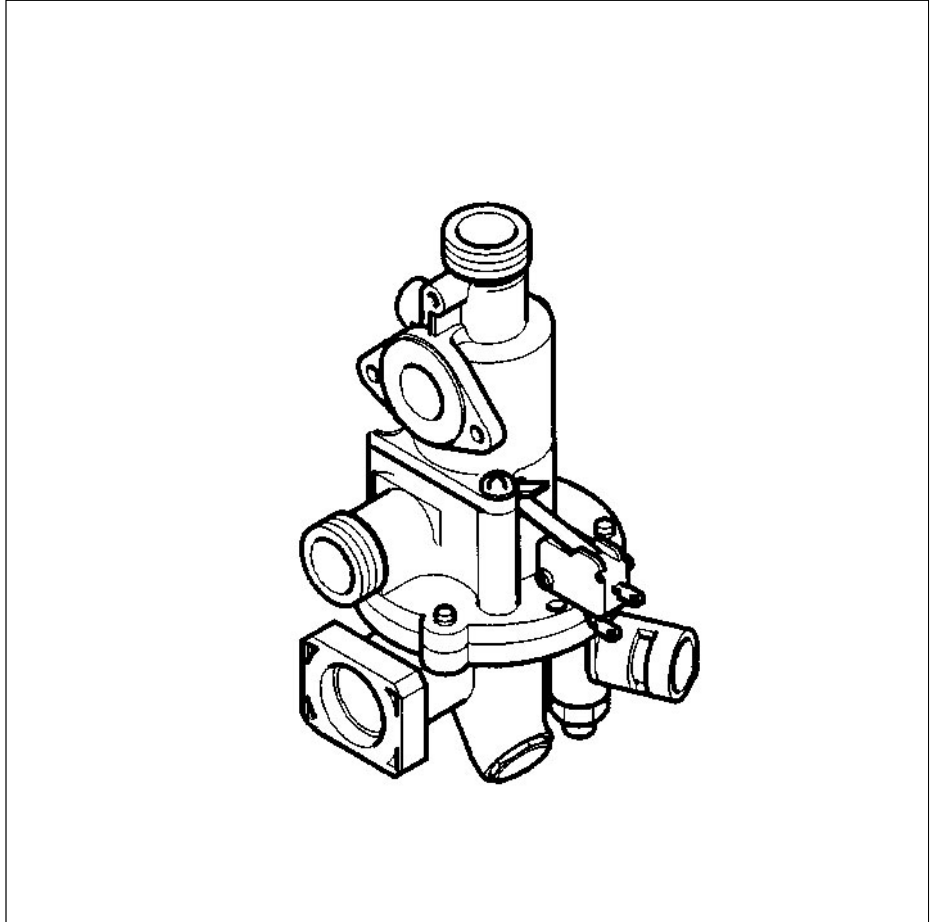

Diverter section
VUW 242,282 E

Page

6 - 7

Main component 01 Diverter section
VUW 242,282 E

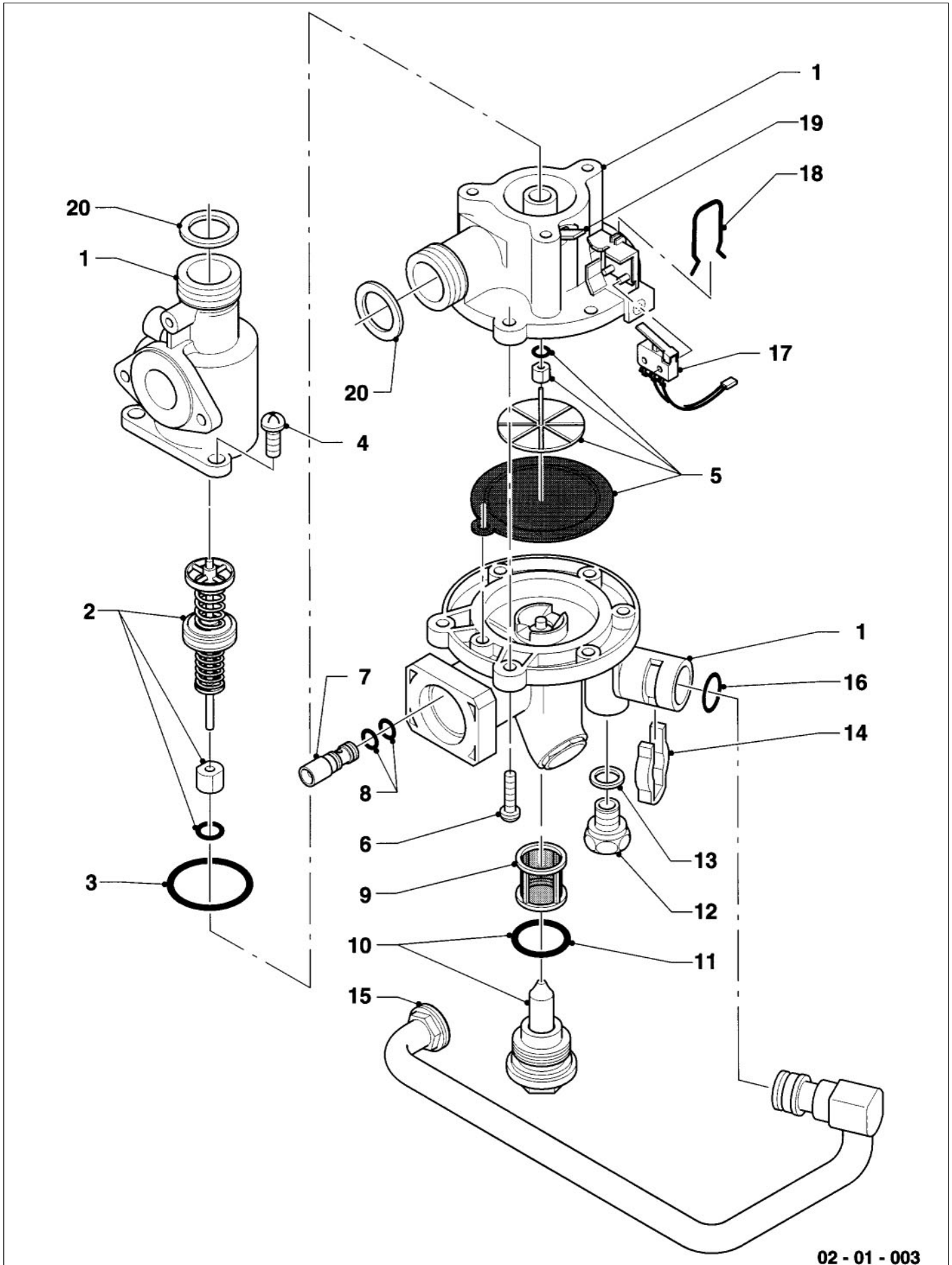

02 - 01 - 003

Main component 01 Diverter section VUW 242,282 E

Pict. No.	Article-No.	Part	Indic.	Type, Remarks
1	01-1289	Diverter valve		supplied with parts 2-13,17-20
2	02-0689	valve disc		supplied with part 3,4
3	98-2329	o-ring		
4	11-8937	screw		
5	01-0365	diaphragm		supplied with part 6
6	11-8946	screw		
7	01-1913	venturi		supplied with part 8
8	98-2459	packingring		
9	12-8519	filter		
10	01-4609	valve		
11	98-2494	o-ring		
12	13-3937	screw		
13	98-1898	packingring		
14	21-9602	bow		supplied with part 16
15	08-9267	connecting tube		
16	98-0149	o-ring		
17	12-6255	micro-switch		
18	15-4150	bow		
19	18-8110	switch lever		
20	98-1511	packingring		
-	-	water quantity limiter		see main component 06 (not shown)

Main component 04

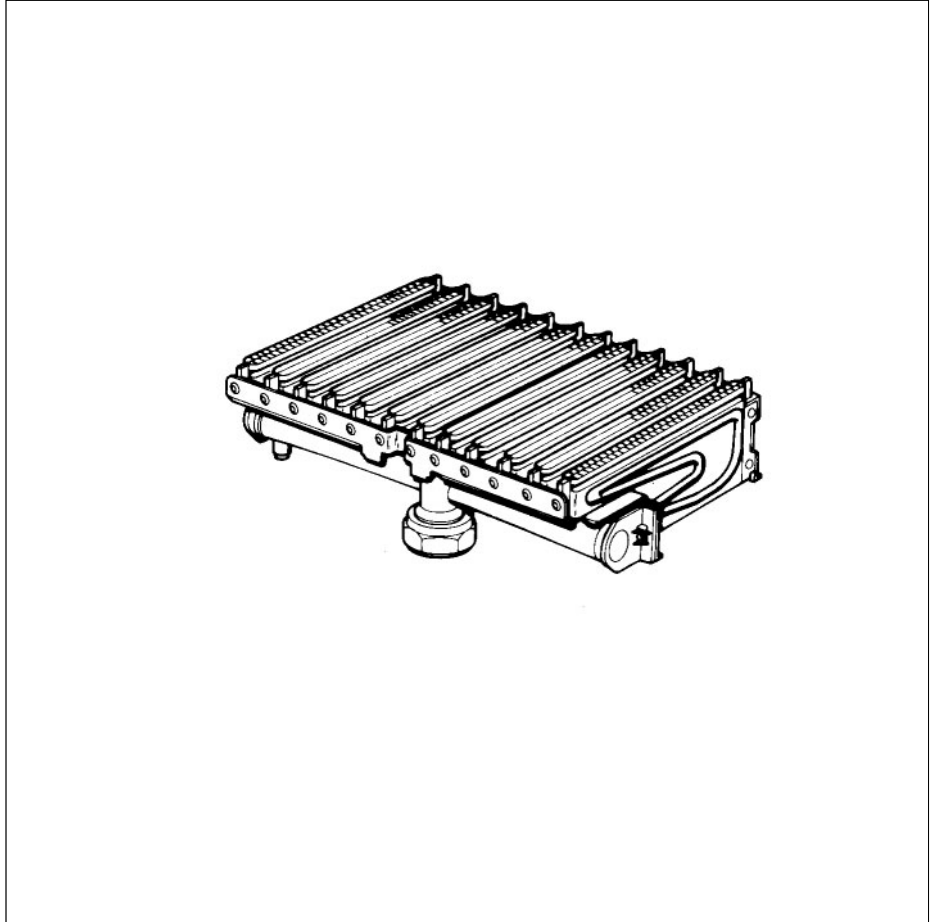

Burner
VU 182,242,282 E, VUW 242, 282 E H,B

Page

10 - 11

Main component 04 Burner
VU 182,242,282 E, VUW 242, 282 E H,B

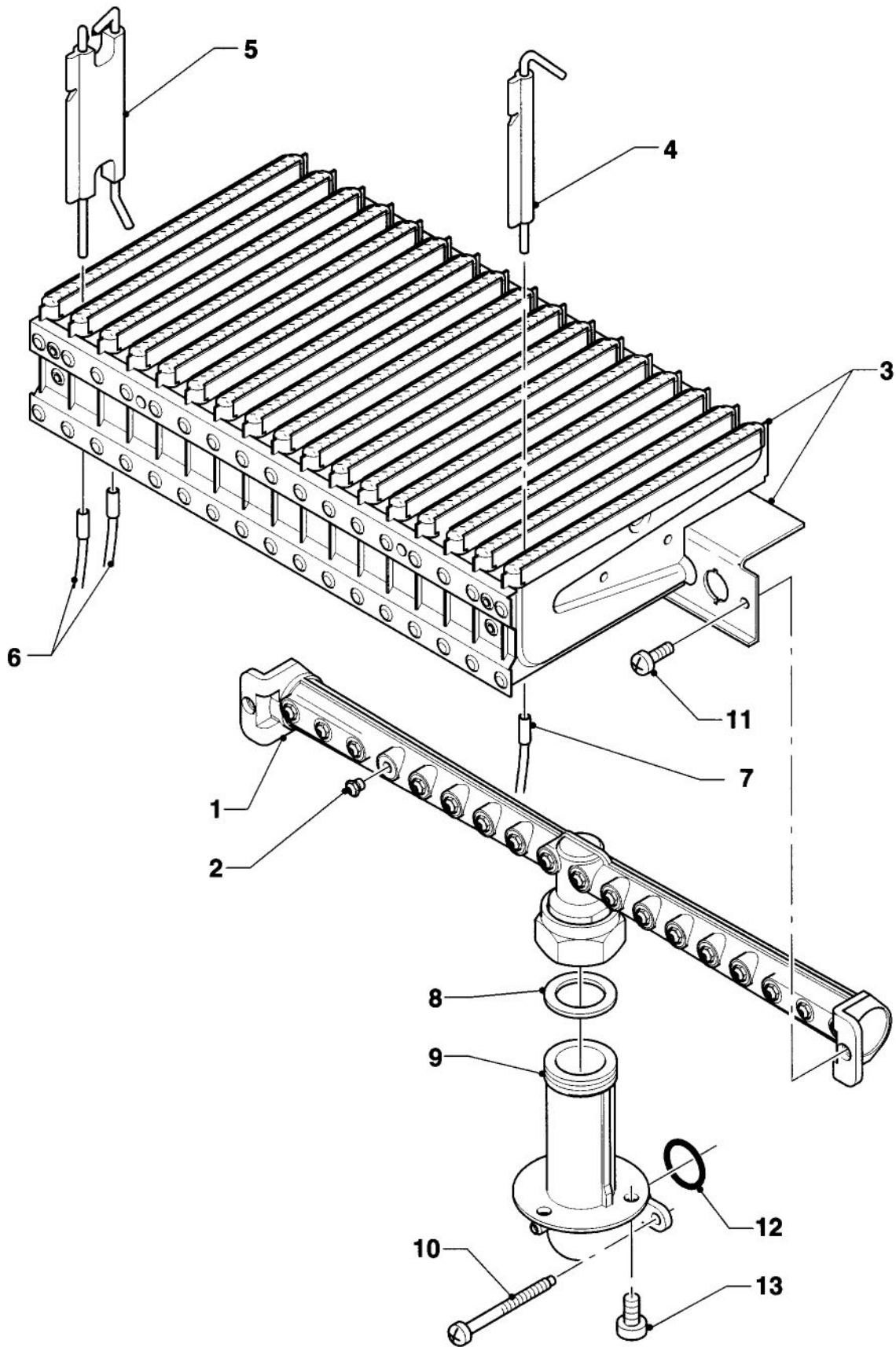

02 - 04 - 004

Main component 04 Burner
VU 182,242,282 E, VUW 242, 282 E H,B

Pict. No.	Article-No.	Part	Indic.	Type, Remarks
1	12-6717	distributor tube		182
	12-6568	distributor tube		242
	12-6570	distributor tube		282
2	24-7120	burner nozzle	ø 1,20	H
	24-7075	burner nozzle	ø 0,75	B
3	04-1981	burner chamber group		182
	04-1960	burner chamber group		242
	04-1961	burner chamber group		282
4	09-0563	monitoring electrode		
5	09-0562	ignition electrode		
6	09-1534	ignition wire		
7	25-6018	cable tree		
8	98-0221	packingring		
9	08-1641	connection piece		
10	11-8944	screw		
11	11-8937	screw		
12	98-2446	o-ring		
13	11-8883	screw		

Main component 05

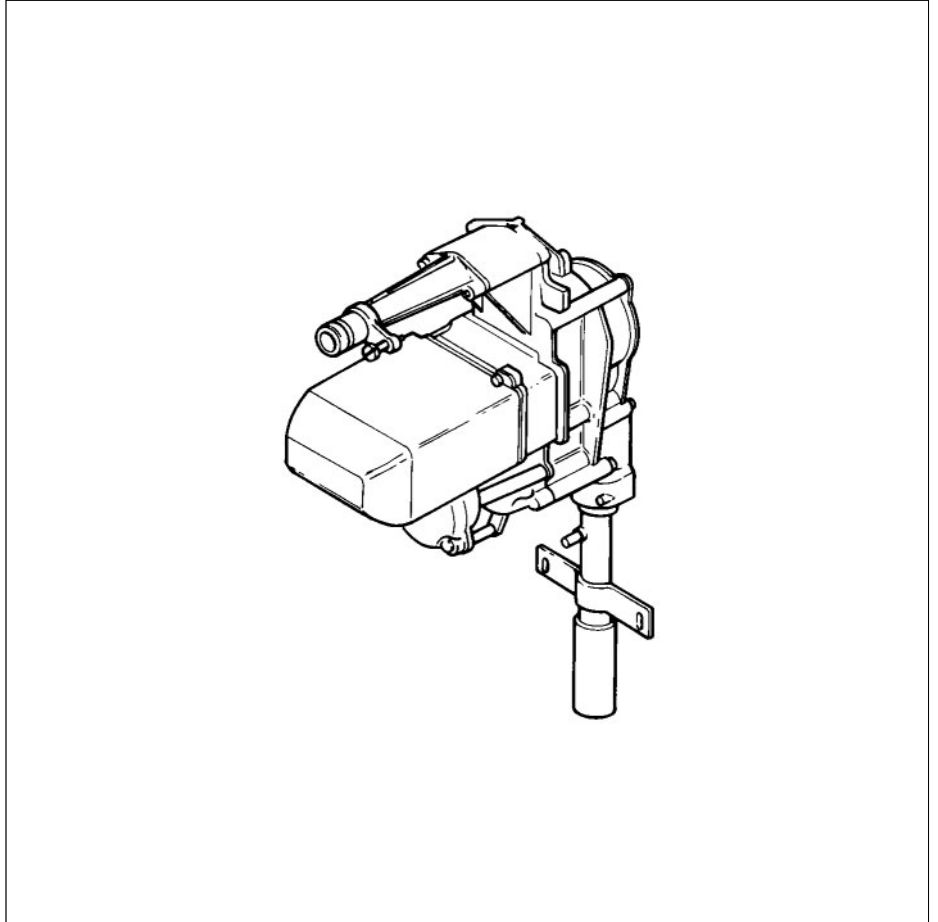

Gas section
VU 182,242,282 E, VUW 242, 282 E H,B

Page

14 - 15

Main component 05 Gas section
VU 182,242,282 E, VUW 242, 282 E H,B

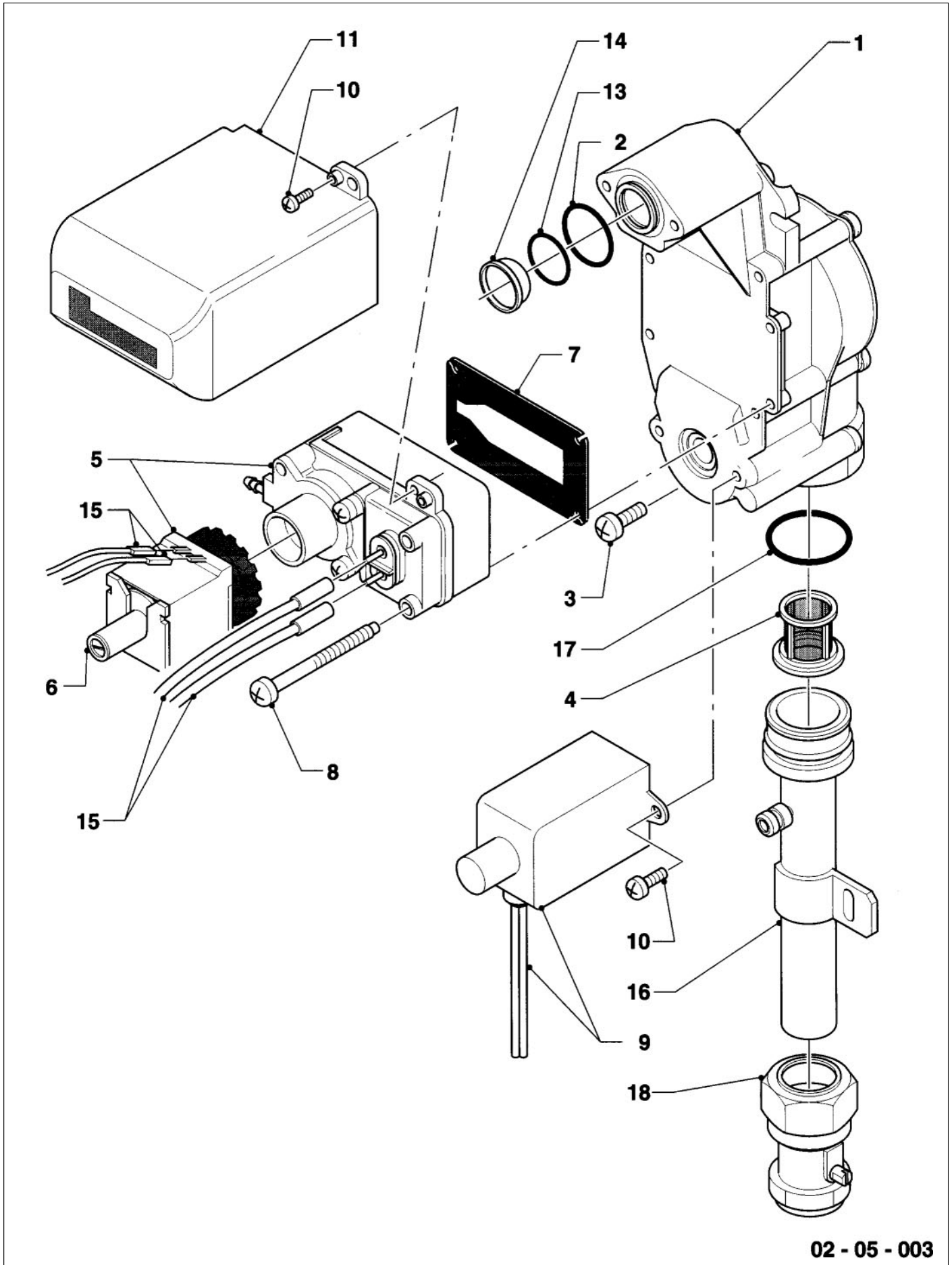

02 - 05 - 003

Main component 05 Gas section
VU 182,242,282 E, VUW 242, 282 E H,B

Pict. No.	Article-No.	Part	Indic.	Type, Remarks
1	05-3210 05-3211	gas section gas section		H (supplied with parts 2-12) B (supplied with parts 2-14)
2	98-2446	o-ring		
3	11-8942	screw		
4	10-8901	filter		
5	05-0222 05-0223	operator operator		H (supplied with part 6,7) B (supplied with part 6,7)
6	17-0363 17-0364	magneto magneto		H B
7	98-0951	packingring		
8	11-8943	screw		
9	17-0365	magneto		
10	11-8883	screw		
11	20-4102	cap		
12	11-8945	screw		
13	98-2314	o-ring		B
14	04-9623 04-9610 04-9611	throttle jet throttle jet throttle jet	2 x ø 3,62 2 x ø 3,10 2 x ø 3,60	182 B 242 B 282 B
15	25-6018	cable tree		
16	08-2602	gas connection		supplied with part 17
17	98-2310	o-ring		
18	08-2750	gas shut-off valve		

Main component 06

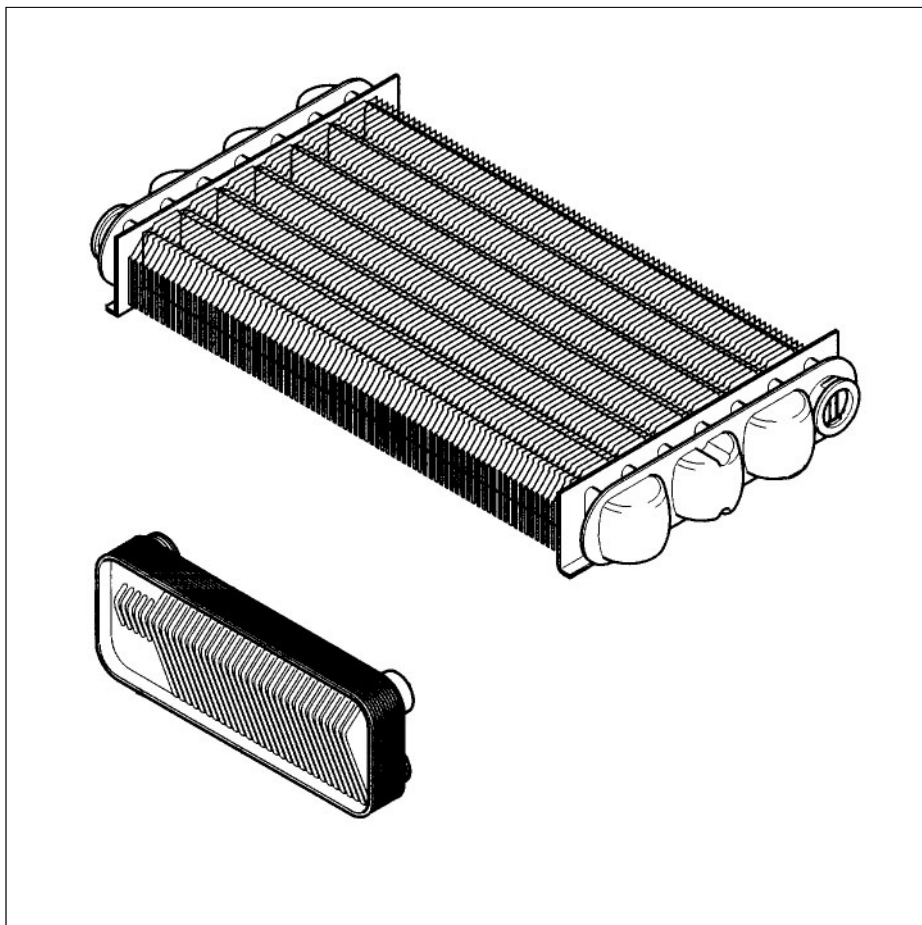

Heat exchanger
VU 182,242,282 E, VUW 242, 282 E

Page

18 - 19

Main component 06 Heat exchanger
VU 182,242,282 E, VUW 242, 282 E

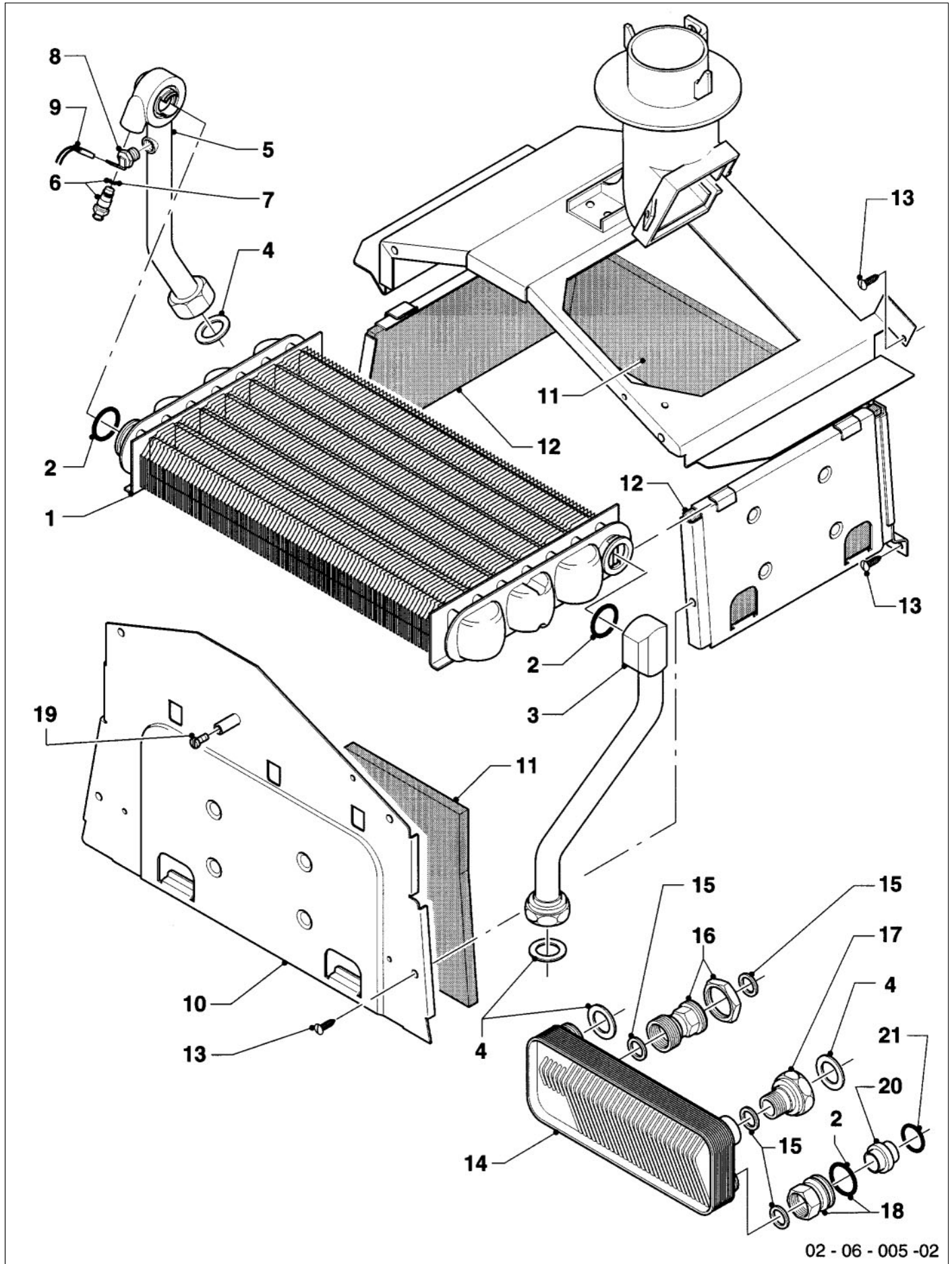

02 - 06 - 005 - 02

Main component 06 Heat exchanger VU 182,242,282 E, VUW 242, 282 E

Pict. No.	Article-No.	Part	Indic.	Type, Remarks
1	06-5009 06-4951 06-4952	heat exchanger heat exchanger heat exchanger		182 (supplied with part 2) 242 (supplied with part 2) 282 (supplied with part 2)
2	98-2331	o-ring		
3	08-9097 08-9084	connecting tube connecting tube		182 (supplied with part 2) 242,282 (supplied with part 2)
4	98-0151	packingring		
5	08-9096 08-9054	connecting tube connecting tube		182 (supplied with part 2,6) 242,282 (supplied with part 2,6)
6	14-0015	de-aeration screw		
7	98-2459	packingring		
8	25-2805	ntc-sensor		
9	25-6018	cable tree		
10	07-0267 07-0266	front cover front cover		182 242,282
11	07-5872 07-5871	insulation (front) insulation (front)		182 242,282
12	07-5870	insulation (side)		
13	23-5715	screw		
14	06-4950	heat exchanger		VUW... (supplied with part 4,15-18)
15	98-1755	packingring		VUW...
16	08-7968	connection piece		VUW...
17	08-7965	connection piece		VUW...
18	08-7967	connection piece		VUW...
19	01-0082	screw		
20	01-2952 01-2953	water quantity limiter water quantity limiter		VUW 242 VUW 282
21	98-2336	o-ring		VUW...

Main component 07

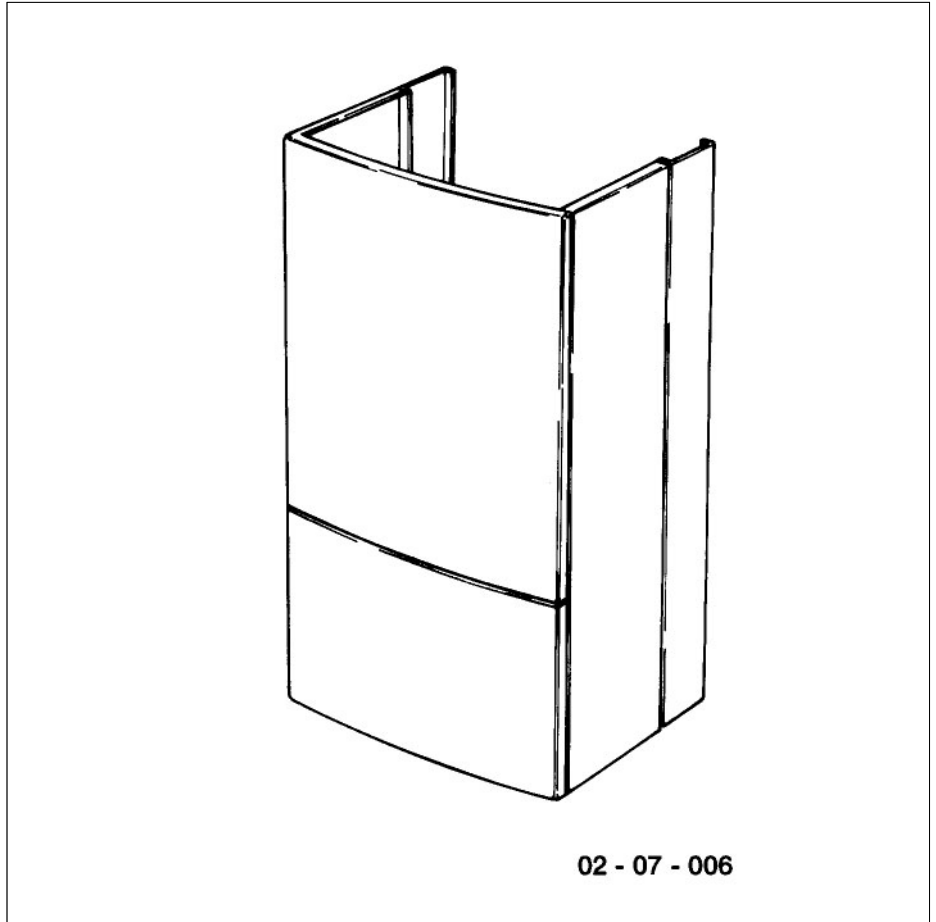

Casing parts

VU 182,242,282 E, VUW 242, 282 E

Combustion chamber, Flue fan

VU 182,242,282 E, VUW 242, 282 E

Page

22 - 23

24 - 25

Main component 07 Casing parts
VU 182,242,282 E, VUW 242, 282 E

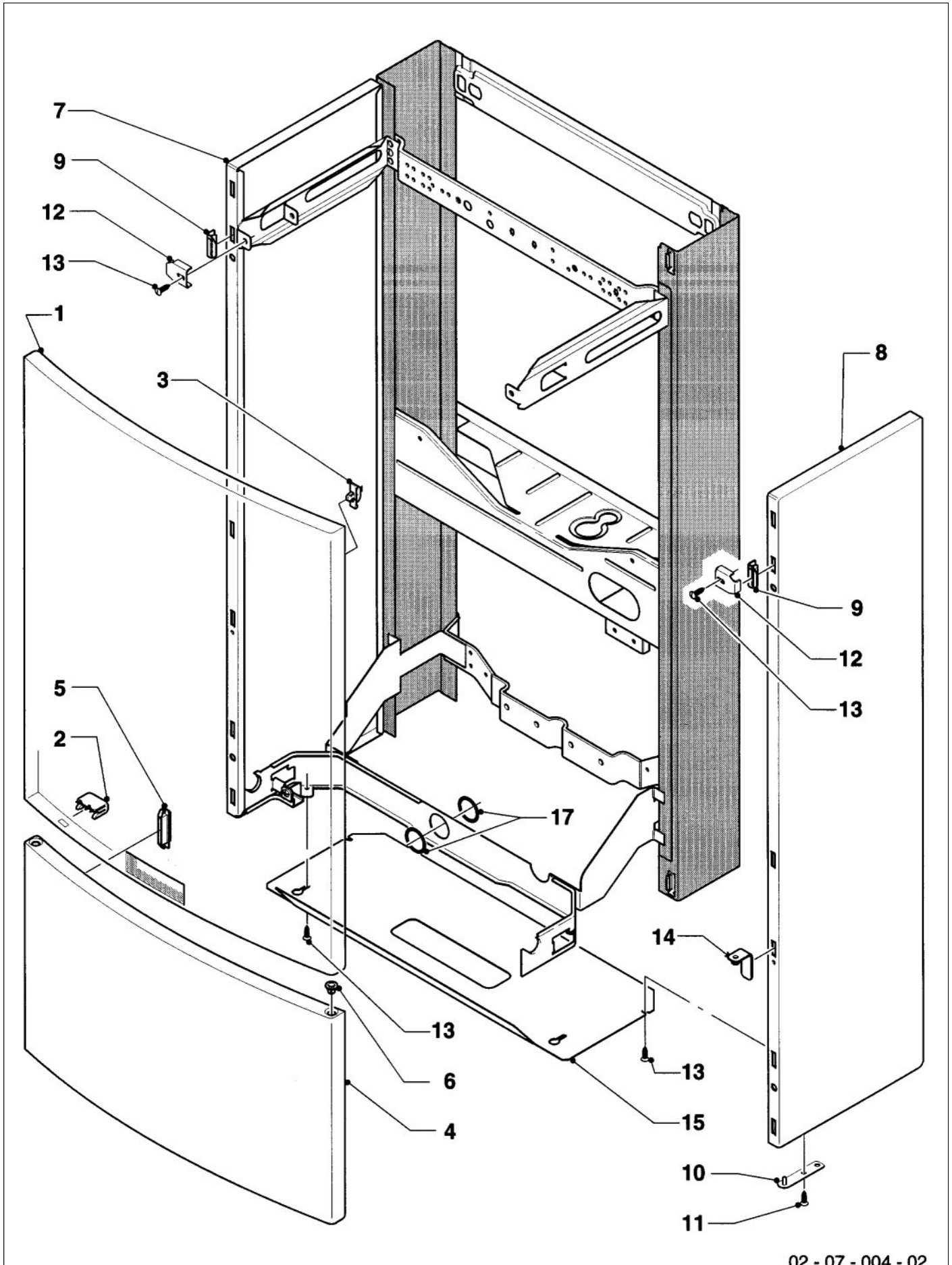

02 - 07 - 004 - 02

Main component 07 Casing parts
VU 182,242,282 E, VUW 242, 282 E

Pict. No.	Article-No.	Part	Indic.	Type, Remarks
1	07-8103	upper front panel,cpl.		supplied with parts 2,3
2	18-3512	guiding bush		
3	08-2922	clip		
4	07-8104	lower front panel,cpl.		supplied with parts 5,6
5	17-0346	magnet		
6	12-4870	bush		
7	07-9995	lateral panel		supplied with part 9
8	07-9996	lateral panel		supplied with parts 9-11
9	28-7036	location piece		
10	08-8019	hinge		supplied with part 11
11	50-0046	screw		
12	08-6907	support		
13	23-5715	screw		
14	08-8018	hinge clip		
15	07-1385	cover		
16	23-5756	screw		
17	98-1756	packingring		

Main component 07 Combustion chamber, Flue fan
VU 182,242,282 E, VUW 242, 282 E

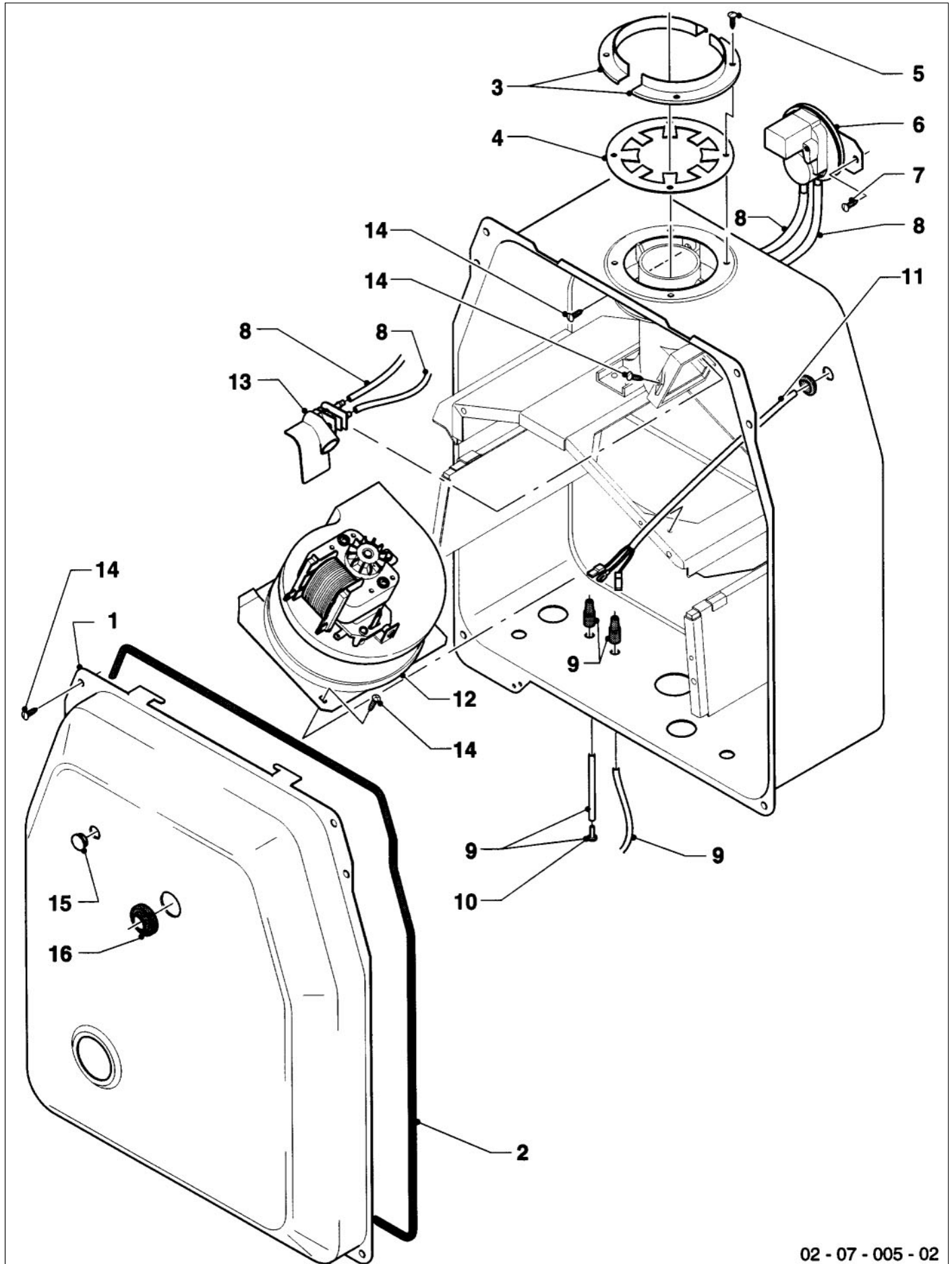

02 - 07 - 005 - 02

**Main component 07 Combustion chamber, Flue fan
VU 182,242,282 E, VUW 242, 282 E**

Pict. No.	Article-No.	Part	Indic.	Type, Remarks	
1	07-1799	cover		supplied with parts 2,15,16	
2	28-2896	sealing profile			
3	29-2208	ring			
4	19-4137	reduction piece			
5	50-0046	screw			
6	05-0557	fan proving switch			
7	23-5753	screw			
8	08-0389	hose			
9	13-3627	nipple			
10	13-9420	plug			
11	25-6018	cable tree			
12	19-0162	flue fan			
13	13-3633	pitot tube			182
	13-3631	pitot tube			242
	13-3626	pitot tube			282
14	23-5715	screw			
15	20-4063	cap			
16	98-0765	packingring			

Main component 08

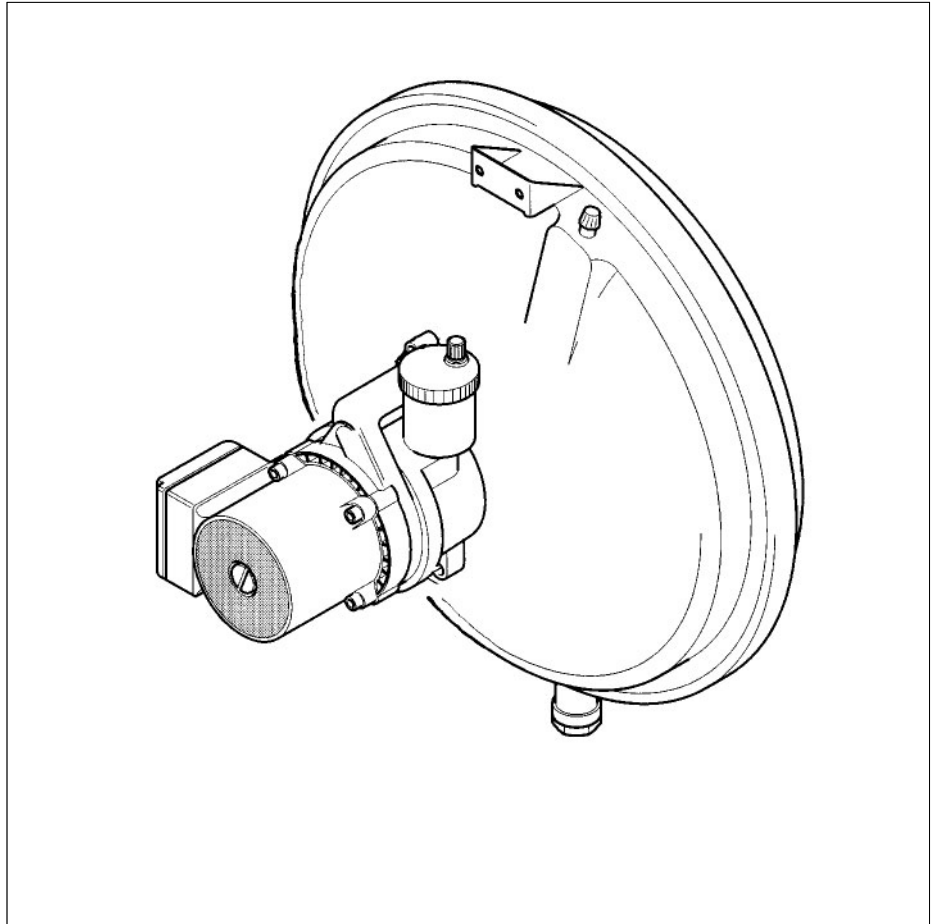

Connection parts
VU 182,242,282 E, VUW 242, 282 E

Page

28 - 31

Main component 08 Connection parts
VU 182,242,282 E, VUW 242, 282 E

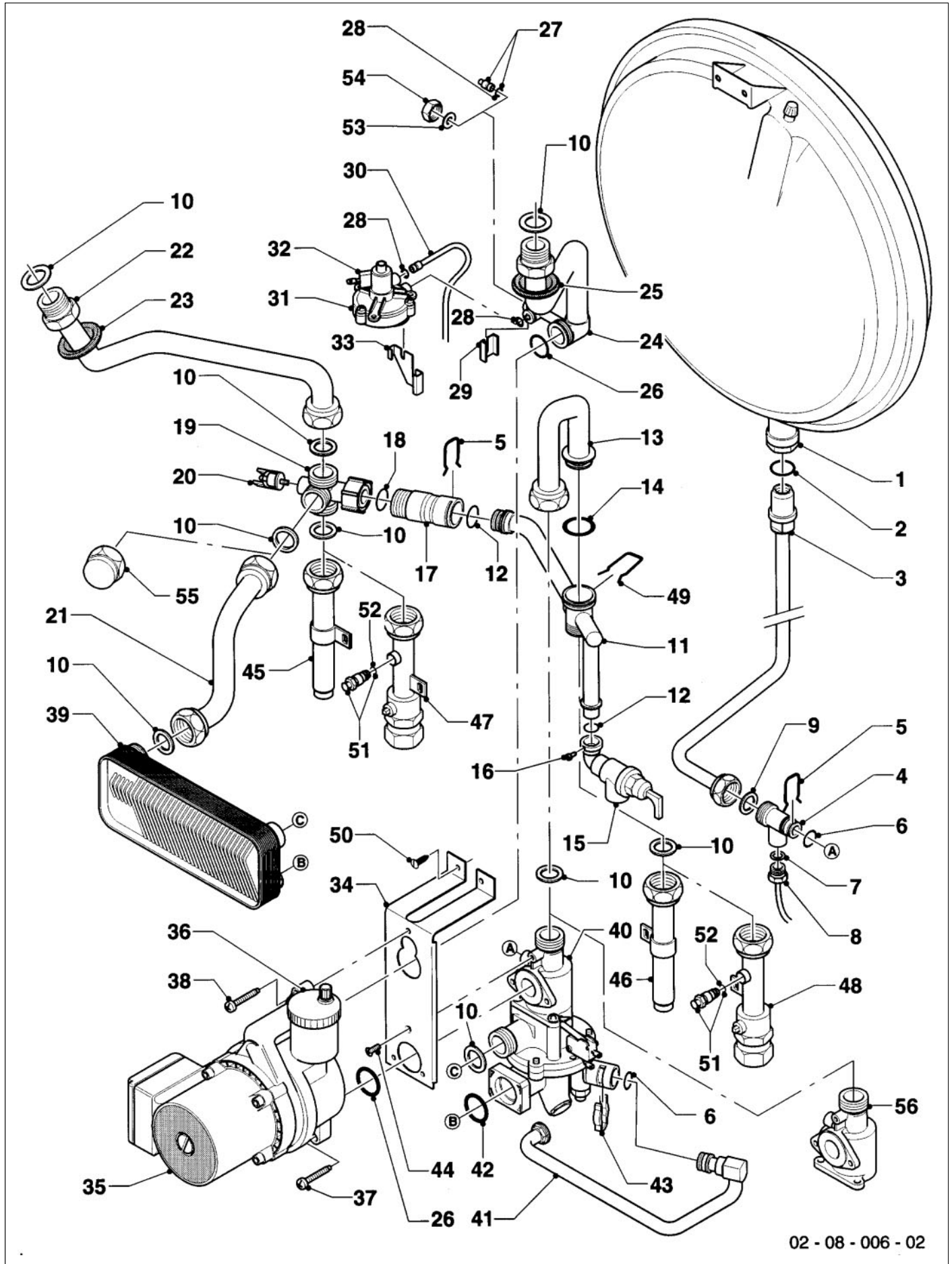

02 - 08 - 006 - 02

Main component 08 Connection parts

VU 182,242,282 E, VUW 242, 282 E

Pict. No.	Article-No.	Part	Indic.	Type, Remarks
1	18-1022	expansion vessel		VU... (not shown)
	18-1045	expansion vessel		VUW...
2	98-2495	packingring		
3	08-1088	connection		
4	08-1644	connection piece		supplied with part 6
5	12-6158	retaining bracket		
6	98-0149	o-ring		
7	98-2484	packingring		
8	10-1558	thermometer		
9	98-0012	packingring		
10	98-1511	packingring		
11	08-0722	service tee		supplied with part 12
12	98-0287	packingring		
13	08-9037	connecting tube		supplied with part 14
14	98-2494	o-ring		
15	19-0717	pressure relief valve		supplied with parts 12,16
16	10-5804	screw		
17	15-0232	spill valve		supplied with parts 5,12,18
18	98-2497	packingring		
19	08-1642	connection piece		supplied with part 18
20	10-0376	safety switch		
21	08-0245	connecting tube		VUW...
22	08-9265	connecting tube		
23	98-0960	packingring		
24	08-9062	connecting tube		supplied with parts 25-29
25	98-0765	packingring		
26	98-2442	packingring		
27	10-9914	plug		
28	98-2490	packingring		
29	08-5751	support		
30	08-8992	flow switch connection		supplied with part 28
31	15-1041	pressure diff. switch		supplied with part 32
32	12-6246	micro-switch		
33	15-4133	bow		
34	08-5784	support		
35	16-1111	pump		supplied with parts 26,36-38
36	06-1707	automatic de-aerator		
37	11-8951	screw		
38	11-8960	screw		

Main component 08 Connection parts
VU 182,242,282 E, VUW 242, 282 E

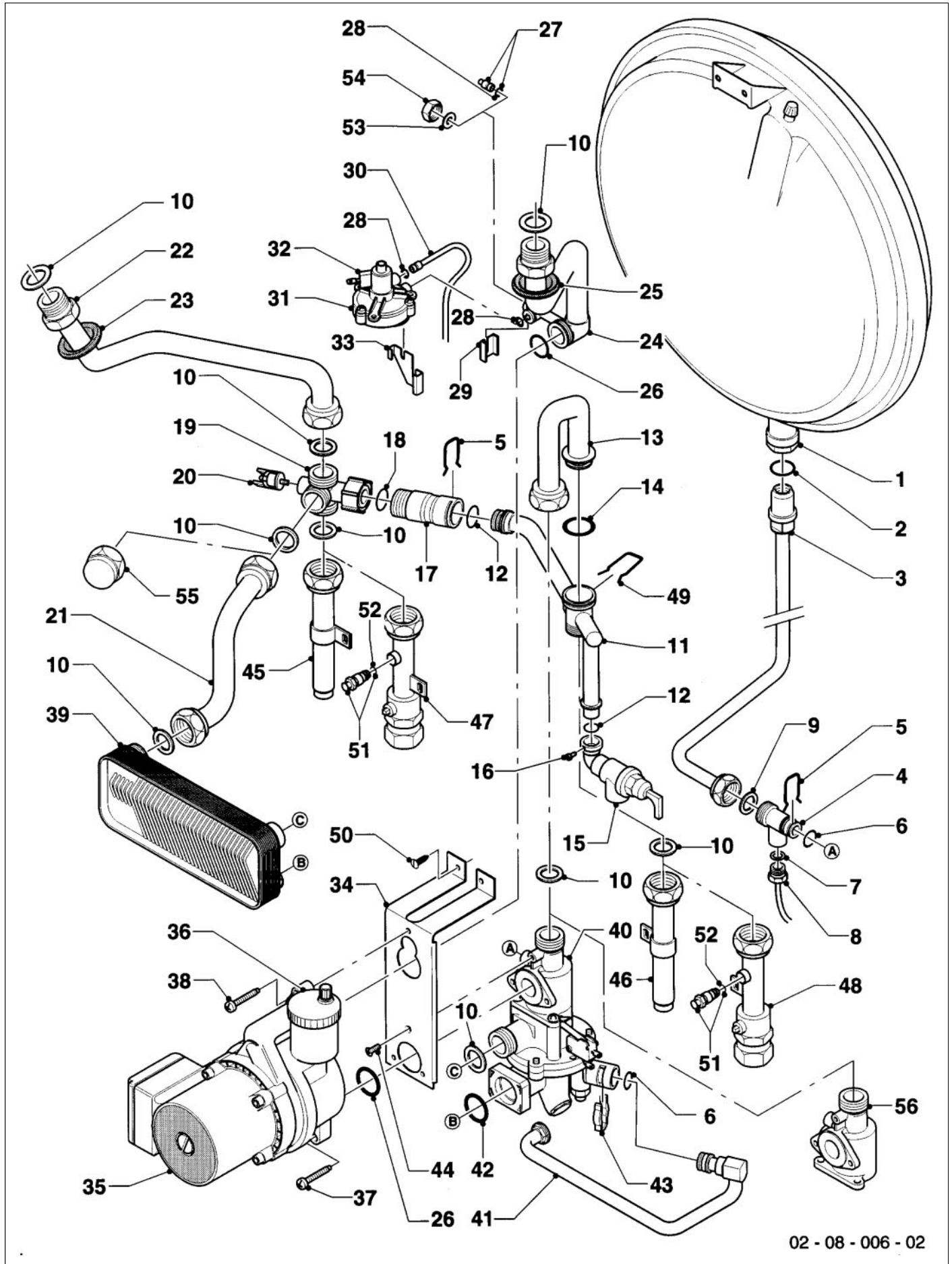

02 - 08 - 006 - 02

Main component 08 Connection parts

VU 182,242,282 E, VUW 242, 282 E

Pict. No.	Article-No.	Part	Indic.	Type, Remarks
39	-	heat exchanger		VUW... (see main component 06)
40	-	diverter section		VUW... (see main component 01)
41	08-9267	connecting tube		VUW... (supplied with part 6)
42	98-2331	o-ring		VUW...
43	21-9602	bow		VUW...
44	20-2622	screw		
45-46	-	-		not necessary for British appliances execution
47-48	13-5729	service cock (flow+return)		supplied with parts 51,52
49	15-4162	bow		
50	23-5715	screw		
51	14-0015	de-aeration screw		
52	98-2459	packingring		
53	98-0138	packingring		
54	13-9451	plug		
55	95-0017	cap		VU...
56	08-7992	connection piece		VU...

Main component 12

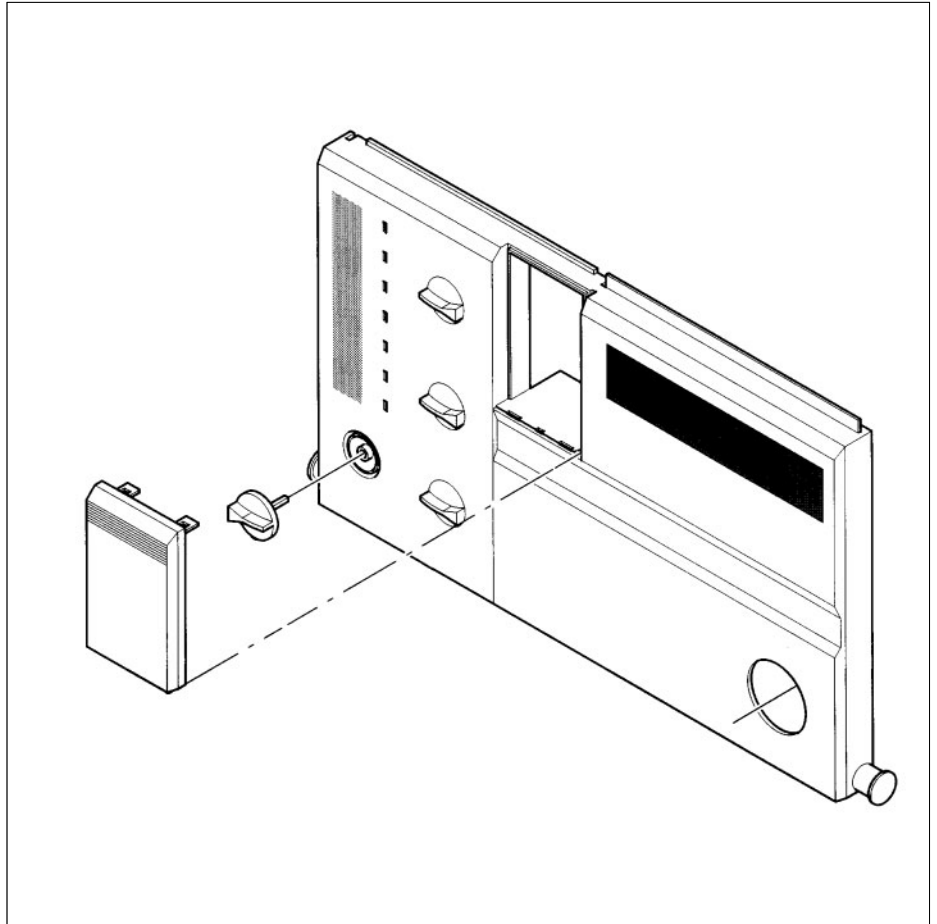

Switch box (Casing)
VU 182,242,282 E, VUW 242, 282 E
Switch box (Printed circuits)
VU 182,242,282 E, VUW 242, 282 E

Page

34 - 35

36 - 37

Main component 12 Switch box (Casing)
VU 182,242,282 E, VUW 242, 282 E

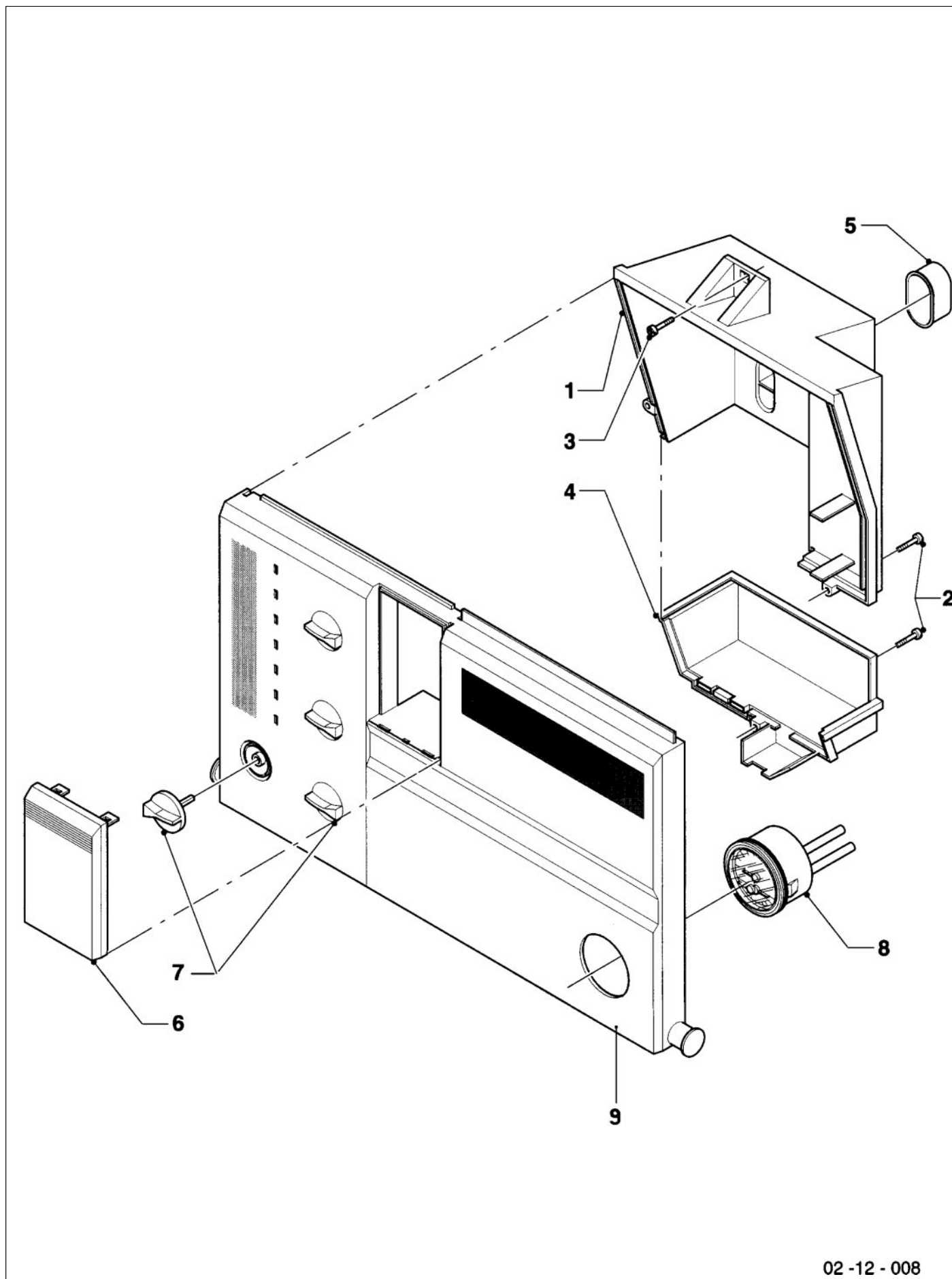

02 -12 - 008

Main component 12 Switch box (Casing)
VU 182,242,282 E, VUW 242, 282 E

Pict. No.	Article-No.	Part	Indic.	Type, Remarks
1	29-5106	casing		supplied with parts 2,3
2	13-9226	screw		
3	23-5760	screw		
4	07-6105	casing		supplied with part 2
5	21-0977	socket		
6	20-9576	cover		
7	14-3996	knob		
8	10-1558	thermometer		
9	29-5158	front cover		VU... (supplied with part 7)
	29-5147	front cover		VUW... (supplied with part 7)

Main component 12 Switch box (Printed circuits)
VU 182,242,282 E, VUW 242, 282 E

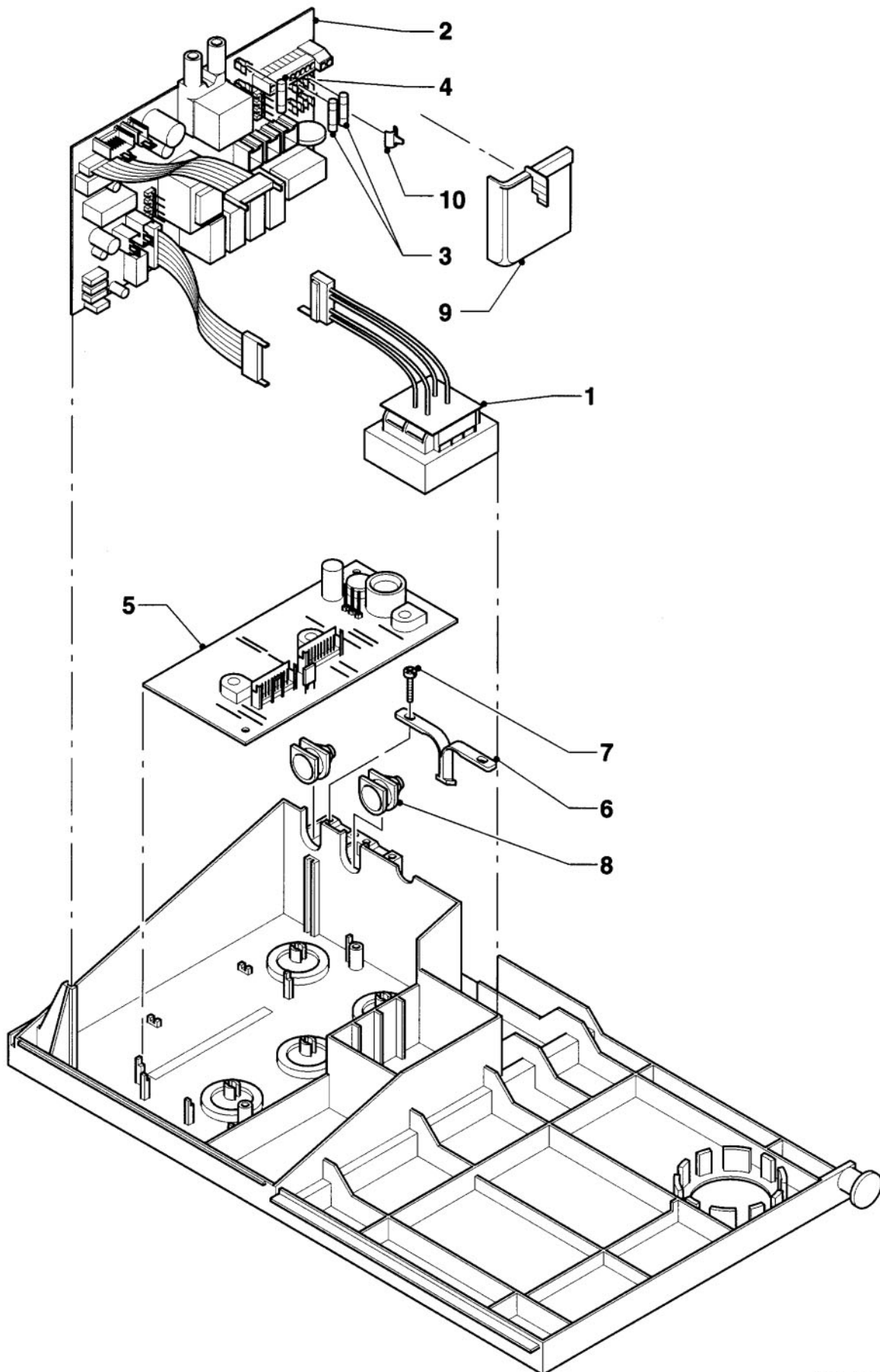

02 - 12 - 009 - 01

Main component 12 Switch box (Printed circuits)
VU 182,242,282 E, VUW 242, 282 E

Pict. No.	Article-No.	Part	Indic.	Type, Remarks
1	28-7442	transformer		
2	13-0391	printed circuit		supplied with parts 3,4
3	13-0037	fuse (2.0 A/250 V)		
4	25-1921	fuse (T 1.25/250V)		
5	13-0390	printed circuit		
6	19-5982	hinge		
7	13-9226	screw		
8	20-1859	cable grommet		
9	07-1373	cover		
10	72-0733	fuse clamp		