

TOSHIBA

FILE NO. A02-009

SERVICE MANUAL**MMS****Modular Multi System****Indoor Unit**

<4-way Air Discharge Cassette Type>

**MMU-P0121H, P0151H, P0181H, P0241H,
MMU-P0301H, P0361H, P0481H**

<2-way Air Discharge Cassette Type>

**MMU-P0071WH, P0091WH, P0121WH,
MMU-P0151WH, P0181WH, P0241WH,
MMU-P0301WH, P0361WH, P0481WH**

<1-way Air Discharge Cassette Type>

**MMU-P0091SH, P0121SH, P0151SH,
MMU-P0181SH, P0241SH**

<Concealed Duct Type>

**MMD-P0071BH, P0091BH, P0121BH,
MMD-P0151BH, P0181BH, P0241BH,
MMD-P0301BH, P0361BH, P0481BH**

<Concealed Duct High Static Pressure Type>

**MMD-P0181H, P0241H, P0361H,
MMD-P0481H, P0721H, P0961H**

<Under Ceiling Type>

**MMC-P0151H, P0181H, P0241H,
MMC-P0361H, P0481H**

<High Wall Type>

**MMK-P0091H, P0121H, P0151H,
MMK-P0181H, P0241H**

<Floor Standing Cabinet Type>

**MML-P0091H, P0151H, P0181H,
MML-P0241H**

<Floor Standing Concealed Type>

**MML-P0091BH, P0151BH,
MML-P0181BH, P0241BH****Outdoor Unit****Cooling Only Model**

<Inverter Unit>

MMY-MP0801T8, MP1001T8

<Fixed-Speed Unit>

**MMY-MP06018, MP08018
MMY-MP10018****Heat Pump Model**

<Inverter Unit>

MMY-MP0801HT8, MP1001HT8

<Fixed-Speed Unit>

**MMY-MP0601H8, MP0801H8
MMY-MP1001H8****Heat Pump Model**

<Inverter Unit>

MMY-MP0801HT7, MP1001HT7

<Fixed-Speed Unit>

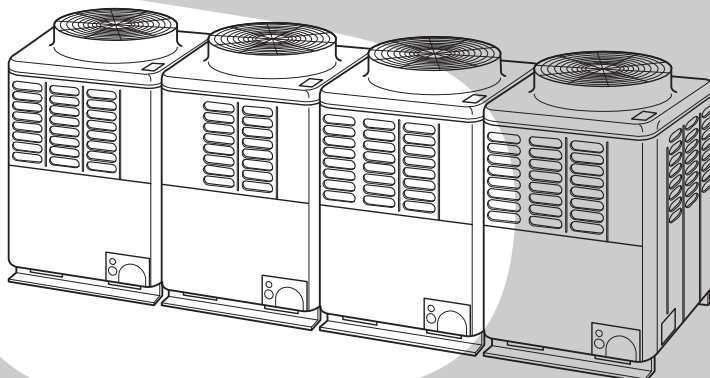
**MMY-MP0601H7, MP0801H7
MMY-MP1001H7**

WARNINGS ON REFRIGERANT LEAKAGE

Check of Concentration Limit

The room in which the air conditioner is to be installed requires a design that in the event of refrigerant gas leaking out, its concentration will not exceed a set limit.

The refrigerant R407C which is used in the air conditioner is safe, without the toxicity or combustibility of ammonia, and is not restricted by laws to be imposed which protect the ozone layer. However, since it contains more than air, it poses the risk of suffocation if its concentration should rise excessively. Suffocation from leakage of R407C is almost non-existent. With the recent increase in the number of high concentration buildings, however, the installation of multi air conditioner systems is on the increase because of the need for effective use of floor space, individual control, energy conservation by curtailing heat and carrying power etc.

Most importantly, the multi air conditioner system is able to replenish a large amount of refrigerant compared with conventional individual air conditioners. If a single unit of the multi conditioner system is to be installed in a small room, select a suitable model and installation procedure so that if the refrigerant accidentally leaks out, its concentration does not reach the limit (and in the event of an emergency, measures can be made before injury can occur). In a room where the concentration may exceed the limit, create an opening with adjacent rooms, or install mechanical ventilation combined with a gas leak detection device.

The concentration is as given below.

$$\frac{\text{Total amount of refrigerant (kg)}}{\text{Min. volume of the indoor unit installed room (m}^3\text{)}} \leq \text{Concentration limit (kg/m}^3\text{)}$$

The concentration limit of R407C which is used in multi air conditioners is 0.3kg/m³.

NOTE 1 :

If there are 2 or more refrigerating systems in a single refrigerating device, the amounts of refrigerant should be as charged in each independent device.

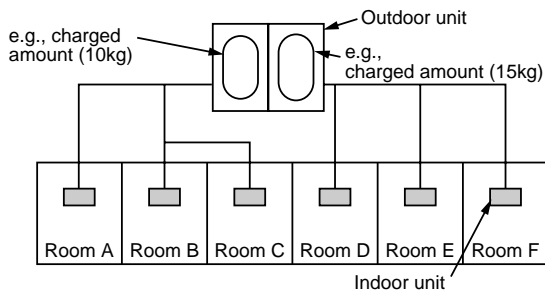

For the amount of charge in this example:

The possible amount of leaked refrigerant gas in rooms A, B and C is 10kg.

The possible amount of leaked refrigerant gas in rooms D, E and F is 15kg.

Important

NOTE : 2

The standards for minimum room volume are as follows.

- (1) No partition (shaded portion)

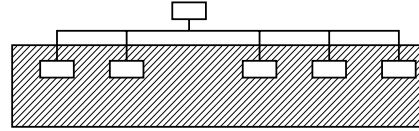

- (2) When there is an effective opening with the adjacent room for ventilation of leaking refrigerant gas (opening without a door, or an opening 0.15% or larger than the respective floor spaces at the top or bottom of the door).

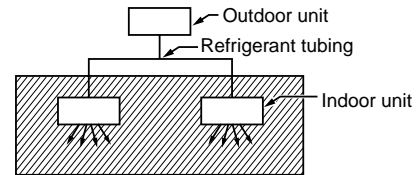

- (3) If an indoor unit is installed in each partitioned room and the refrigerant tubing is interconnected, the smallest room of course becomes the object. But when a mechanical ventilation is installed interlocked with a gas leakage detector in the smallest room where the density limit is exceeded, the volume of the next smallest room becomes the object.

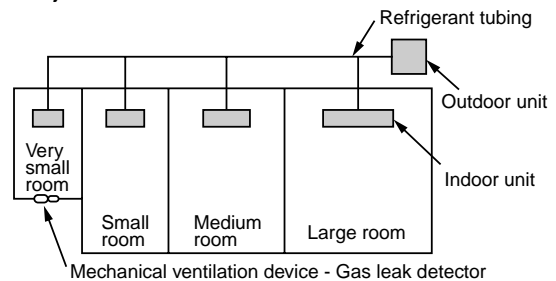

NOTE 3 :

The minimum indoor floor area compared with the amount of refrigerant is roughly as follows: (When the ceiling is 2.7m high)

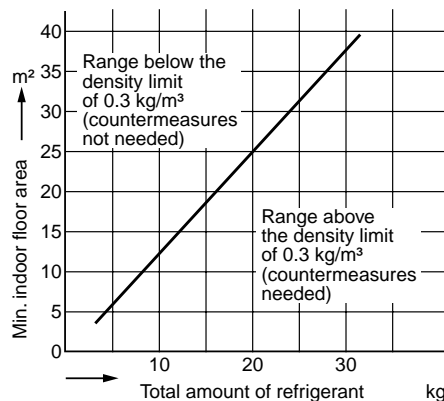

This Manual is used for both models, Cooling Only model and Heat Pump model.

Positions shaded with screens  in the description and tables are applied to the Heat Pump model only.

Parts marked with **XXX** indicate the 60Hz, 380V model only.

CONTENTS

SECTION 3 SERVICE MANUAL	3-1
SAFETY NOTES.....	3-1
SELECTING A LOCATION FOR INSTALLATION	3-2
3-1. PARTS SPECIFICATIONS	3-3
3-2. OWNER'S MANUAL	3-7
3-3. REFRIGERANT PIPING SYSTEMATIC DRAWING	3-18
3-4. COMBINED REFRIGERANT PIPING SYSTEMATIC DRAWING	3-22
3-5. OUTLINE OF CONTROL	3-26
3-6. TROUBLESHOOTING	3-38
3-7. CONTROL CIRCUIT CONFIGURATION	3-107
3-8. EMERGENCY OPERATION	3-131
3-9. FORCED FUNCTION OF OIL LEVEL DETECTION (OUTDOOR UNIT)	3-135
3-10. REFRIGERANT RECOVERY METHOD WHEN REPLACING THE COMPRESSOR	3-136
3-11. REPLACEMENT OF COMPRESSOR	3-140
3-12. REPLACING METHOD OF PARTS	3-146
3-13. EXPLODED VIEWS AND PARTS LIST	3-148

SECTION 3 SERVICE MANUAL

SAFETY NOTES

- Read these Safety Notes carefully before installing this unit.
- These Safety Notes contain very important safety information. Always be sure to observe these cautions.
- After installation is complete, try the operation of the unit to make sure that it is operating normally. Be certain to instruct the customer about how to operate the unit, and about necessary maintenance. Give this Installation Manual to the customer along with the Owner's Manual, and recommend that the customer keeps both for future reference.

WARNINGS

- **The dealer or a special contractor must install this unit.**
Attempts to install this unit by a customer could result in leaks, electric shock, or fire.
- **Follow these instructions carefully when installing this unit.**
Improper installation could result in leaks, electric shock, or fire.
- **If this unit is installed in a small room, measures must be taken to ensure that, even in the event of a refrigerant leak, the maximum safe limit for refrigerant concentration levels in the air is not exceeded.**
Consult the dealer for details on what measures can be taken to keep from exceeding the maximum safe limit. If a refrigerant leak does cause refrigerant concentration levels in the air to exceed the maximum safe limit, asphyxiation could result.
- **Select a location for installation that will be able to safely bear the weight of the unit.**
If the installation location is not strong enough to support the unit and the unit falls, injury could result.
- **Install the unit in the prescribed manner to withstand strong (hurricane-level) winds and earthquakes.**
Insufficiently secure installation could allow the unit to tip over, fall, or otherwise cause an accident.
- **Ventilate the area if any refrigerant leaks during installation.**
If the refrigerant comes into contact with an open flame, it will produce a toxic gas.
- **After completing installation, make sure that no refrigerant is leaking.**
If the refrigerant leaks indoors and comes into contact with an open flame in a water heater, stove, oven, or other such appliance, it will produce a toxic gas.
- **Electrical work must be performed by a qualified electrician as described in the Installation Manual. The unit must be connected to its own independent circuit.**
Inadequate circuit capacity or improper installation could result in electric shock or fire.
- **Wiring must be performed securely, using the prescribed cables. The cables must be secured in a manner that prevents any force that pulls on the cables from being relayed to the terminal connectors.**
If the cables are not connected or secured properly, fire or other accidents could result.
- **The unit must be grounded.**
Do not connect the ground wire to a gas pipe, water pipe, lightning rod, or telephone ground wire. When wiring the system to the main power supply, follow the standards established by the local power company. Inadequate grounding can result in electric shock.

CAUTIONS

- **Install a ground fault interrupter.**
If a ground fault interrupter is not installed, electric shock could result.
- **Do not install the unit in a location where combustible gases could conceivably leak.**
Leaking gases that accumulate in the vicinity of the unit could be ignited by the unit.

SELECTING A LOCATION FOR INSTALLATION

WARNINGS

- **Select a location for installation that will be able to safely bear the weight of the unit.**
If the installation location is not strong enough to support the unit and the unit falls, injury could result.

CAUTION

- **Do not install the unit in a location where combustible gases could conceivably leak.**
Leaking gases that accumulate in the vicinity of the unit could be ignited by the unit.

Obtain permission from the customer to install the unit in a location that satisfies the following requirements:

- A location that permits level installation of the unit
- A location that provides enough space to service the unit safely
- A location where water draining from the unit will not pose a problem

Avoid the following types of locations:

- Locations where salt is present in large amounts (seaside areas), or where sulfuric gases are present in large amounts (hot springs areas) (If the unit is to be used in such areas, special maintenance is necessary.)
- Locations that generate oils (including machine oils), steam, oily smoke, or corrosive gases
- Locations where organic solvents are used
- Locations in the vicinity of equipment that generates high frequency signals
- Locations where the outdoor unit will blow in the direction of a neighbor's window
- Locations where the noise of the outdoor unit will pose a problem
- Locations with poor air circulation

3-1. PARTS SPECIFICATIONS

Indoor unit

4-way Air Discharge Cassette Type

Model	MMU-	P0121H	P0151H	P0181H	P0241H	P0301H	P0361H	P0481H
Fan motor		ICF-230-60-1				MF-200-90-2		
Drain pump motor		PJD-05230TF						
Float switch		FS-0208-602						
Control P.C. board transformer		(Control P.C.B) SWT66 Remo-con/Power TT-02						
Pulse motor	EDM-	MD12TF-3						
Pulse motor valve	EDM-	B252TF-1 (F25)	B402TF-1 (F40)				B602TF-1 (F60)	
Pressure sensor		150F/160NH6-D						
Louver motor (panel)		MT8-3-9						

1-way Air Discharge Cassette Type

Model	MMU-	P0091SH	P0121SH	P0151SH	P0181SH	P0241SH
Fan motor		AF-200-22-4N-1		AF-200-34-4D		
Running capacitor for fan motor		450V 1.0 μ F		400V 1.5 μ F		400V 2.5 μ F
Drain pump		PJV-0774		PJD-05230TF		
Float switch		FS-085-003E		FS-0208-601		
Control P.C. board transformer		TT-03				
Pulse motor	EDM-	MD12TF-3				
Pulse motor valve	EDM-	B252TF-1 (F25)		B402TF-1 (F40)		
Pressure sensor		150F/160NH6-D				
Louver motor (Panel)		MT-8-3-4				

Concealed Duct Type

Model	MMD-	P0071BH	P0091BH	P0121BH	P0151BH	P0181BH	P0241BH	P0301BH	P0361BH	P0481BH
Fan motor	STF-	200-60-4D				200-60-4C	200-100-4E	200-100-4F	200-120-4D	200-140-4G
Running capacitor for fan motor		450V 2 μ F		500V 2.5 μ F		400V 5.0 μ F		400V 6 μ F	400V 10 μ F	
Control P.C. board (Transformer)		TT-03								
Float switch		FS-0208-601								
Drain pump motor		PJD-05230TF								
Pulse motor	EDM-	MD12TF-3								
Pulse motor valve		EDM-B252TF-1 (F25)				EDM-B402TF-1 (F40)				
Pressure sensor		150F/160NH6-D								
Louver motor		MT8-3-6								

High Wall Type

Model	MMK-	P0091H	P0121H	P0151H	P0181H	P0241H
Fan motor		MF-200-30-4A				MF-200-30-4B
Running capacitor for fan motor		400V 1.0 μ F		450V 1.5 μ F		
Control P.C. board (Transformer)		TT-03				
Pulse motor	EDM-	MD12TF-3				
Pulse motor valve	EDM-	B252TF-1 (F25)		B402TF-1 (F40)		
Pressure sensor		150F/160NH6-D				
Louver motor		MT8-3-6				

Cooling only model

50Hz

Outdoor unit

Part name	Model name or rating				
	MMY-MP0801T8 (8HP inverter)	MMY-MP1001T8 (10HP inverter)	MMY-MP06018 (6HP fixed-speed)	MMY-MP08018 (8HP fixed-speed)	MMY-MP10018 (10HP fixed-speed)
Compressor	MG1450CW-21B		YG890C-B1	YG1700CW-B1	YG1800CW-B1
Inner overload relay	OFF : 115°C				
Fan motor	STF-200-350A, AC220-240V, 350W Protection relay OFF : 145°C, ON : 86°C				
High-pressure SW	20PS-G ON : 3.2MPa, OFF : 2.55MPa, (normal open contact)				
High-pressure SW	ACB-JBD8 OFF : 3.2Mpa, ON : 2.55Mpa, (normal close contact)		—		
Pressure sensor (For high pressure)	150NH4-H, 0-3.3MPa				
Pressure sensor (For low pressure)	150NH4-L, 0-0.98MPa				
Crank case heater	—		AC240V, 40W	AC240V, 74W	
Heater for accumulator	AC 240V, 26W				
Electronic control valve (For cooling bypass)	SEV18RC4 (Main unit) A12A15 (Coil), DC12V				
2-way valve	NEV202DXF (Main unit) NEV-MOAJ510B0 (Coil), AC220-240V				
	NEV603DXF (Main unit) NEV-MOAJ510B0 (Coil), AC220-240V				

Outdoor controller

Part name	Model name or rating				
	MMY-MP0801T8 (8HP inverter)	MMY-MP1001T8 (10HP inverter)	MMY-MP06018 (6HP fixed-speed)	MMY-MP08018 (8HP fixed-speed)	MMY-MP10018 (10HP fixed-speed)
Power supply voltage	3 Phase, AC380 / 400 / 415V, 50Hz				
Power supply terminal block	60A, 3P (1pc.) and 30A, 3P (1pcs.)				
Communication line terminal block	1A, 4P (1pcs.)		1A, 2P (1pcs.)		
Magnet switch (Fixed compressor)	3 Phase, AC440V, 15A				
Fuse (Power supply)	AC 600V, 20A (3pcs.)		—		
Fuse holder	AC 600V, 30A (3pcs.)		—		
Reactor	CH-25 (2pcs.)		—		
Smoothing capacitor	2200μF, 400V (2pcs.)		—		
Fan capacitor	8μF, 450VAC (1pcs.)				
Power supply transformer	TT-01 (1pcs.)				
P.C. board (Noise filter)	MCC-1366		—		
Line filter (AC)	600μH, 20A (2pcs.)		—		
P.C. board (Interface)	MCC-1343				
P.C. board (IPDU)	MCC-1342		—		
Magnet switch (Power)	AC440V, 13A (1pcs.)		—		
Power complex module	7MBR35SB120 (MCC-1342)		—		
P.C. board (Lightning surge)	—		MCC-1357		

Heat pump model

50Hz

Outdoor unit

Part name	Model name or rating				
	MMY-MP0801HT8 (8HP inverter)	MMY-MP1001HT8 (10HP inverter)	MMY-MP0601H8 (6HP fixed-speed)	MMY-MP0801H8 (8HP fixed-speed)	MMY-MP1001H8 (10HP fixed-speed)
Compressor	MG1450CW-21B		YG8900-B1	YG1700CW-B1	YG1800CW-B1
Inner overload relay	OFF : 115°C				
Fan motor	STF-200–350A, AC220–240V, 350W Protection relay OFF : 145°C, ON : 86°C				
High-pressure SW	ACB-JB128 ON : 3.2MPa, OFF : 2.55MPa, (normal open contact)				
High-pressure SW	ACB-JA64 OFF : 3.2Mpa, ON : 2.55Mpa, (normal close contact)		—		
Pressure sensor (For high pressure)	150NH4-H, 0–3.3MPa				
Pressure sensor (For low pressure)	150NH4-L, 0–0.98MPa				
Crank case heater	—		AC240V, 40W	AC240V, 74W	
Heater for accumulator	AC240V, 26W				
Electronic control valve (For main throttle)	CEV30RC1 (Main unit) L12A-03 (Coil), DC12V				
Electronic control valve (For cooling bypass)	SEV18RC4 (Main unit) A12A15 (Coil), DC12V				
4-way valve	CHV-0712 (Main unit)		CHV-0401 (Main unit)	CHV-0712 (Main unit)	
	CHV-01AJ502E1 (Coil), AC220–240V				
2-way valve	NEV202DXF (Main unit) NEV-MOAJ510B0 (Coil), AC220–240V				
	NEV603DXF (Main unit) NEV-MOAJ510B0 (Coil), AC220–240V				

Outdoor controller

Part name	Model name or rating				
	MMY-MP0801HT8 (8HP inverter)	MMY-MP1001HT8 (10HP inverter)	MMY-MP0601H8 (6HP fixed-speed)	MMY-MP0801H8 (8HP fixed-speed)	MMY-MP1001H8 (10HP fixed-speed)
Power supply voltage	3 Phase, AC380 / 400 / 415V, 50Hz				
Power supply terminal block	60A, 3P (1pc.) and 30A, 3P (1pc.)				
Communication line terminal block	1A, 4P (1pc.)		1A, 2P (1pc.)		
Magnet switch (Fixed compressor)	3 Phase, AC440V, 15A				
Fuse (Power supply)	AC 600V, 20A (3pcs.)		—		
Fuse holder	AC 600V, 30A (3pcs.)		—		
Reactor	CH-25 (2pcs.)		—		
Smoothing capacitor	2200μF, 400V (2pcs.)		—		
Fan capacitor	8μF, 450VAC (1pc.)				
Power supply transformer	TT-01 (1pc.)				
P.C. board (Noise filter)	MCC-1366		—		
Line filter (AC)	600μH, 20A (2pcs.)		—		
P.C. board (Interface)	MCC-1343				
P.C. board (IPDU)	MCC-1342		—		
Magnet switch (Power)	AC440V, 13A (1pc.)		—		
Power complex module	7MBR35SB120 (MCC-1342)		—		
P.C. board (Lightning surge)	—		MCC-1357		

Outdoor unit

Part name	Model name or rating				
	MMY-MP0801HT7 (8HP inverter)	MMY-MP1001HT7 (10HP inverter)	MMY-MP0601H7 (6HP fixed-speed)	MMY-MP0801H7 (8HP fixed-speed)	MMY-MP1001H7 (10HP fixed-speed)
Compressor	MG1450CW-22B		YG8900-3B	YG1700CW-3B	YG1800CW-3B
Inner overload relay	OFF : 115°C				
Fan motor	STF-200-350A, AC220V, 350W Protection relay OFF : 145°C, ON : 86°C				
High-pressure SW	ACB-JB128 ON : 3.2MPa, OFF : 2.55MPa, (normal open contact)				
High-pressure SW	ACB-JA64 OFF : 3.2Mpa, ON : 2.55Mpa, (normal close contact)		—		
Pressure sensor (For high pressure)	150NH4-H, 0-3.3MPa				
Pressure sensor (For low pressure)	150NH4-L, 0-0.98MPa				
Crank case heater	—		AC240V, 40W	AC240V, 74W	
Heater for accumulator	AC240V, 26W				
Electronic control valve (For main throttle)	CEV30RC1 (Main unit) L12A-03 (Coil), DC12V				
Electronic control valve (For cooling bypass)	SEV18RC4 (Main unit) A12A15 (Coil), DC12V				
4-way valve	CHV-0712 (Main unit)		CHV-0401 (Main unit)	CHV-0712 (Main unit)	
	CHV-01AJ502E1 (Coil), AC220-240V				
2-way valve	NEV202DXF (Main unit) NEV-MOAJ510B0 (Coil), AC220-240V				
	NEV603DXF (Main unit) NEV-MOAJ510B0 (Coil), AC220-240V				

Outdoor controller

Part name	Model name or rating				
	MMY-MP0801HT7 (8HP inverter)	MMY-MP1001HT7 (10HP inverter)	MMY-MP0601H7 (6HP fixed-speed)	MMY-MP0801H7 (8HP fixed-speed)	MMY-MP1001H7 (10HP fixed-speed)
Power supply voltage	3 Phase, AC380V, 60Hz				
Power supply terminal block	60A, 3P (1pc.) and 30A, 3P (1pc.)				
Communication line terminal block	1A, 4P (1pc.)		1A, 2P (1pc.)		
Magnet switch (Fixed compressor)	3 Phase, AC440V, 15A				
Fuse (Power supply)	AC 600V, 20A (3pcs.)		—		
Fuse holder	AC 600V, 30A (3pcs.)		—		
Reactor	CH-25 (2pcs.)		—		
Smoothing capacitor	2200μF, 400V (2pcs.)		—		
Fan capacitor	10μF, 450VAC (1pc.)				
Power supply transformer	TT-01 (1pc.)				
P.C. board (Noise filter)	MCC-1366		—		
Line filter (AC)	600μH, 20A (2pcs.)		—		
P.C. board (Interface)	MCC-1343				
P.C. board (IPDU)	MCC-1342		—		
Magnet switch (Power)	AC440V, 13A (1pc.)		—		
Power complex module	7MBR35SB120 (MCC-1342)		—		
P.C. board (Lightning surge)	—		MCC-1357		

3-2. OWNER'S MANUAL

3-2-1. Name of Each Part

3-2-1-1. Outdoor unit

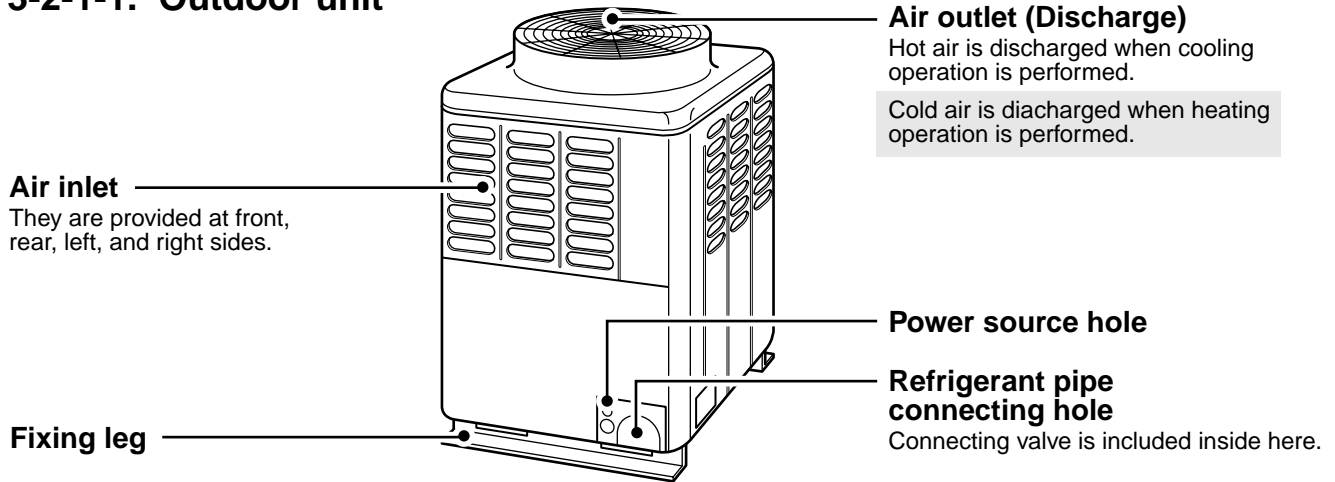

3-2-1-2. Indoor unit

[4-way Air Discharge Cassette Type]

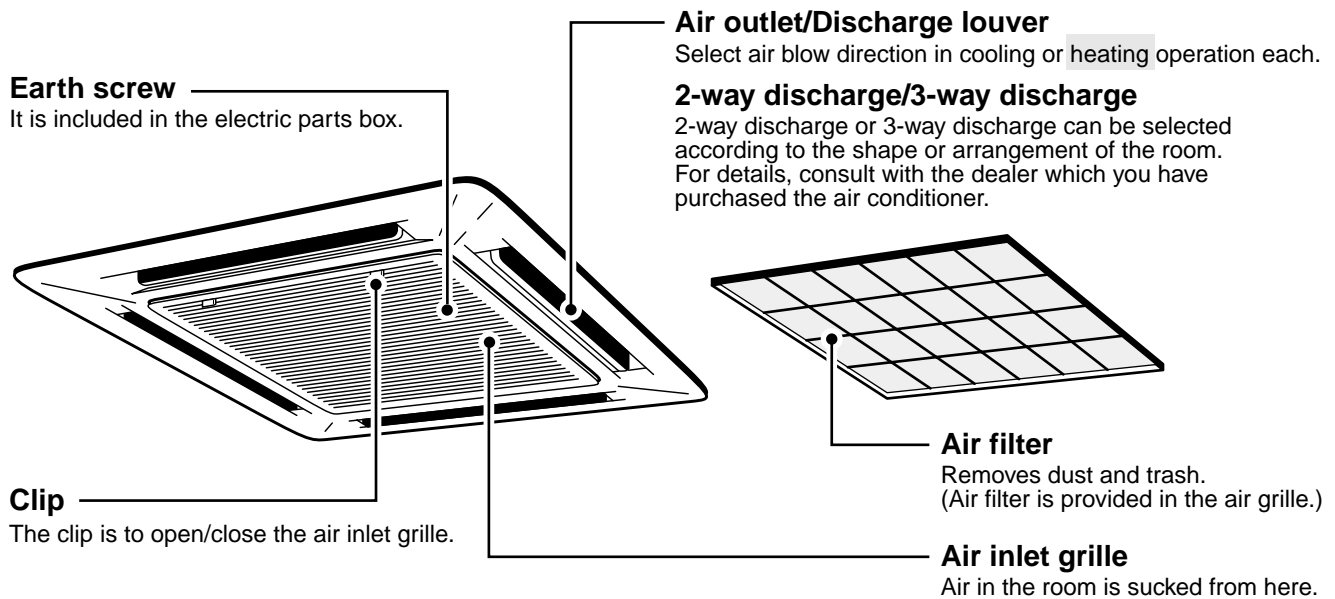

[2-way Air Discharge Cassette Type]

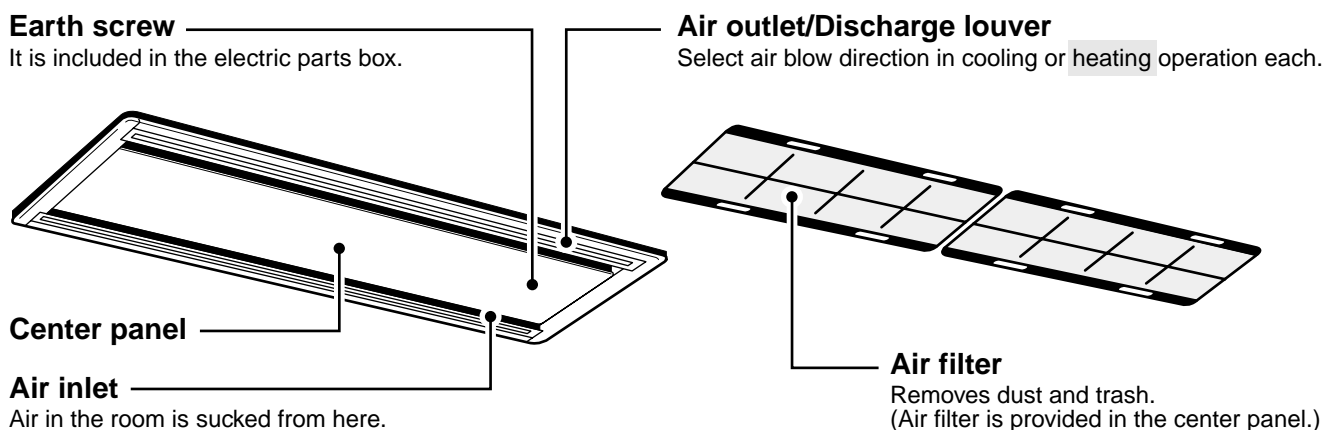

[1-way Air Discharge Cassette Type]

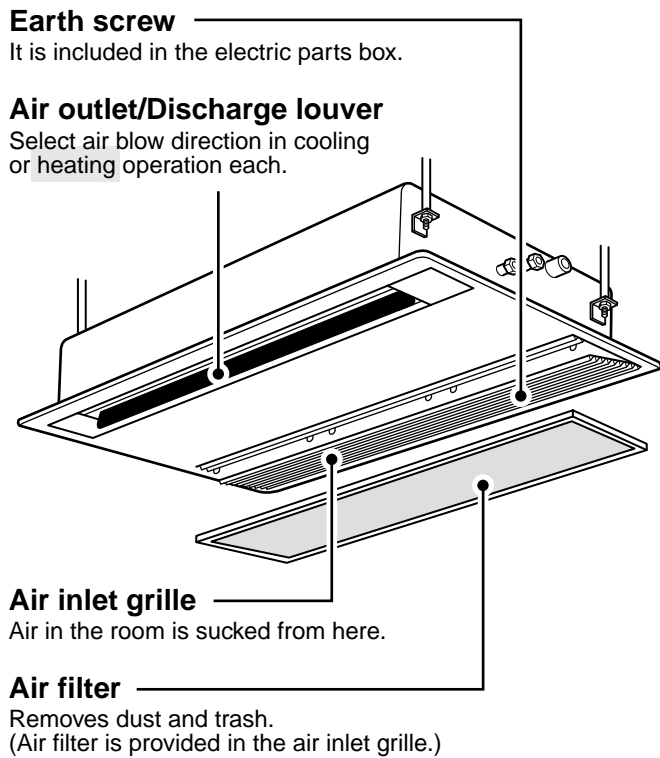

[Concealed Duct type]

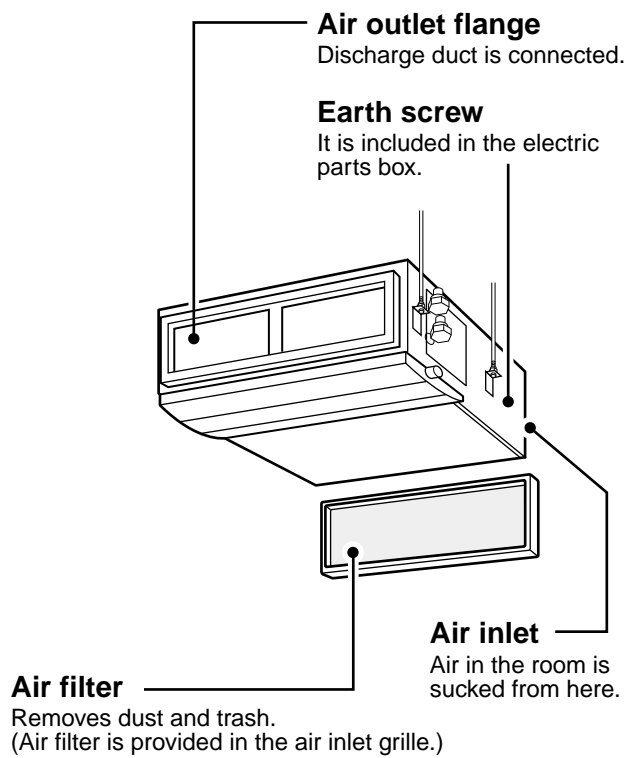

[1-way Air Discharge Cassette Type]

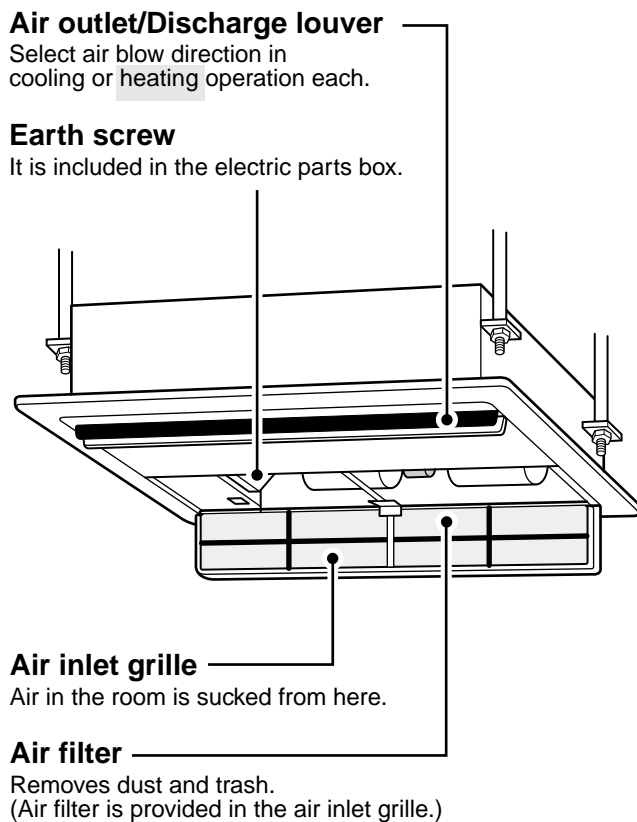

[Concealed Duct High Static Pressure Type]

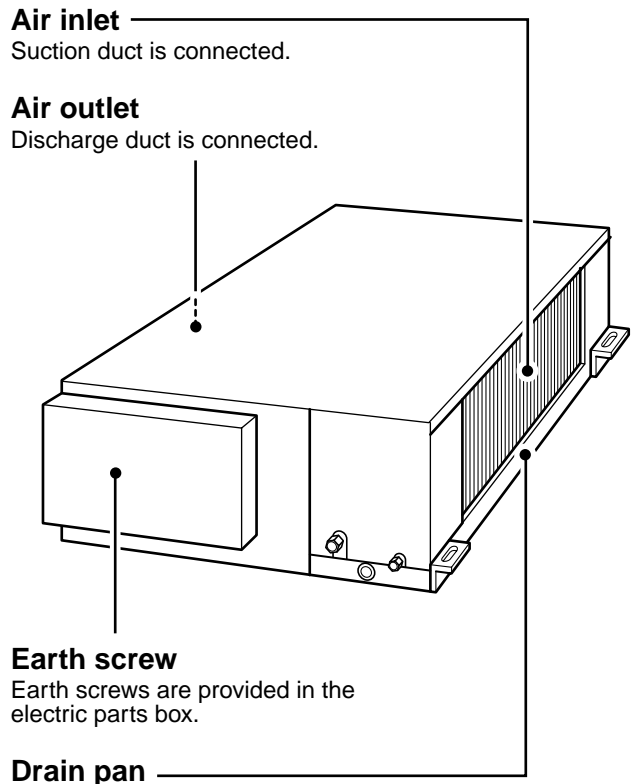

[Under Ceiling Type]

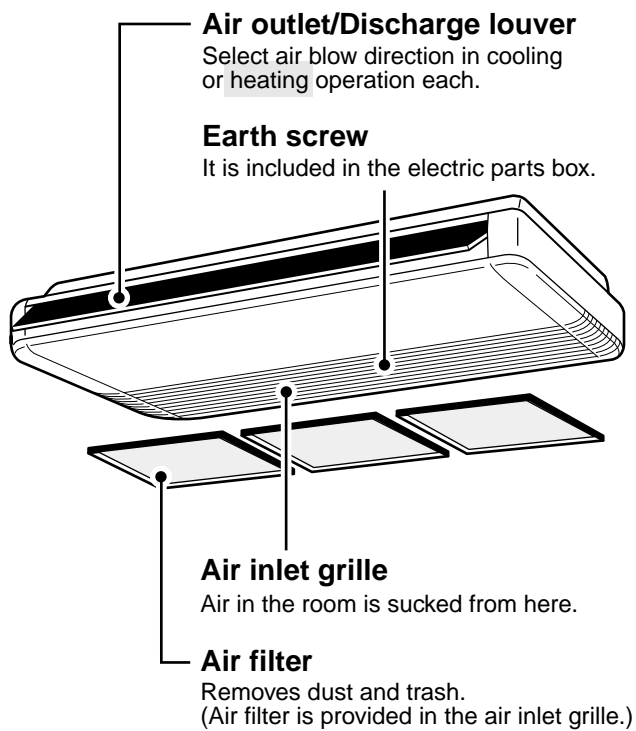

[Floor Standing Cabinet Type]

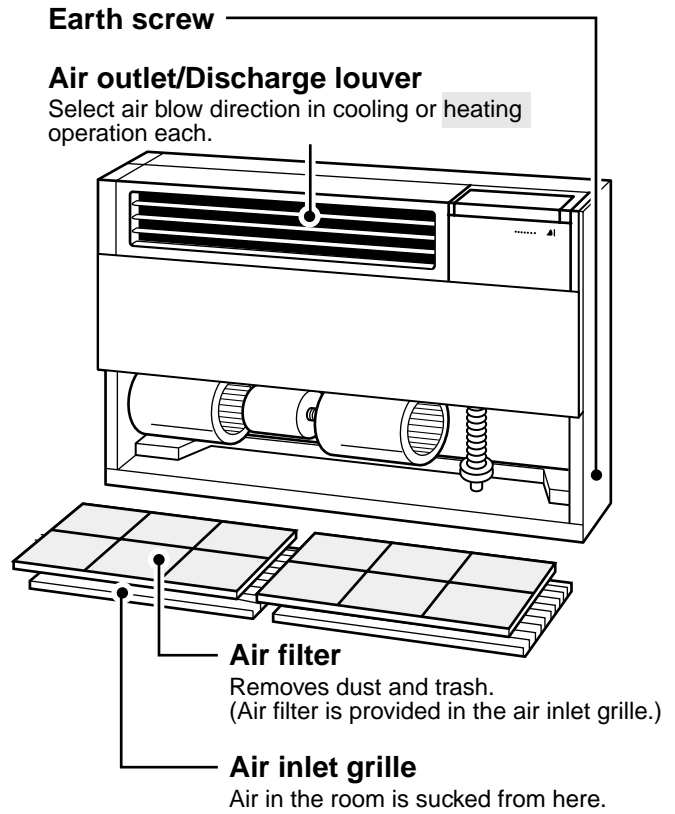

[High Wall Type]

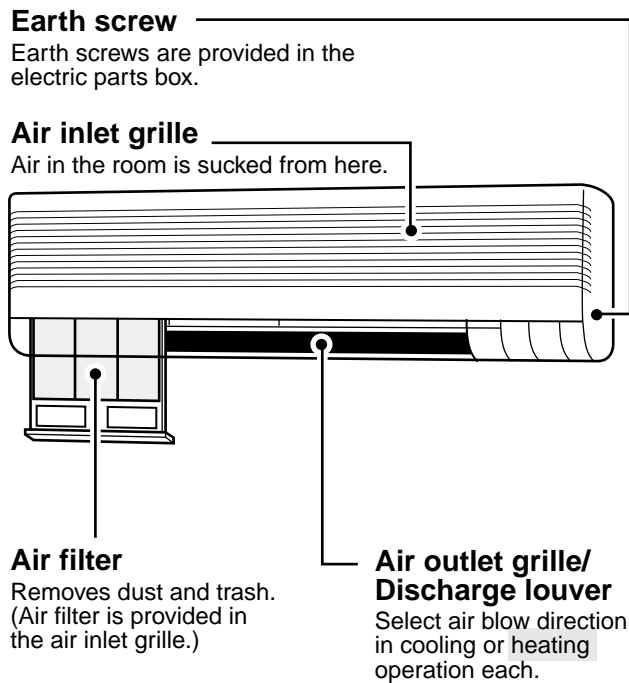

[Floor Standing Concealed Type]

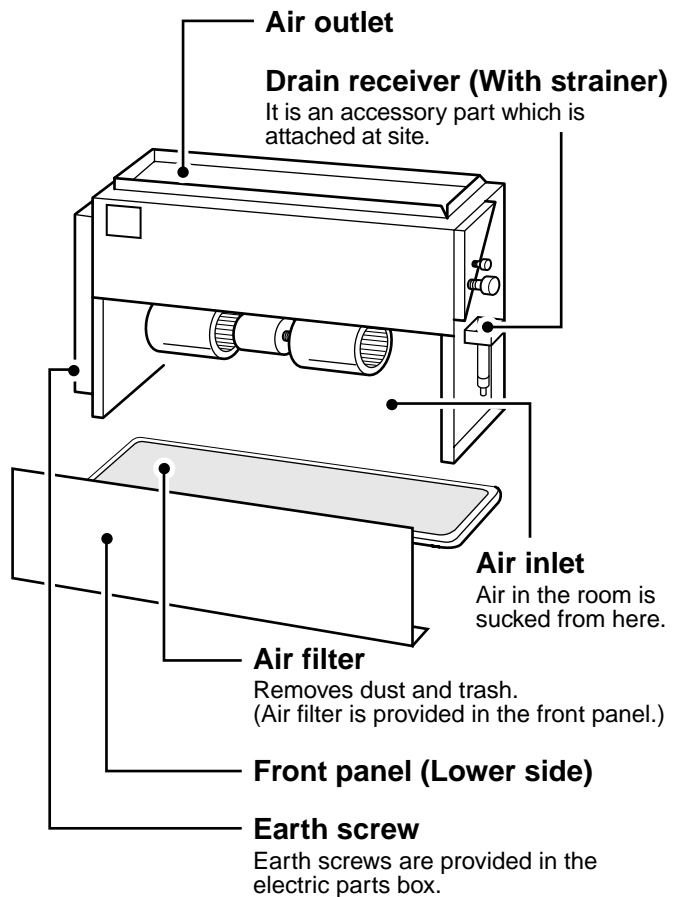

3-2-2. Names and Operations of Remote Controller

3-2-2-1. Display section

In the display example, all are displayed for explanation.

In real time, the selected contents are indicated. The displayed contents differ according to shape or type.

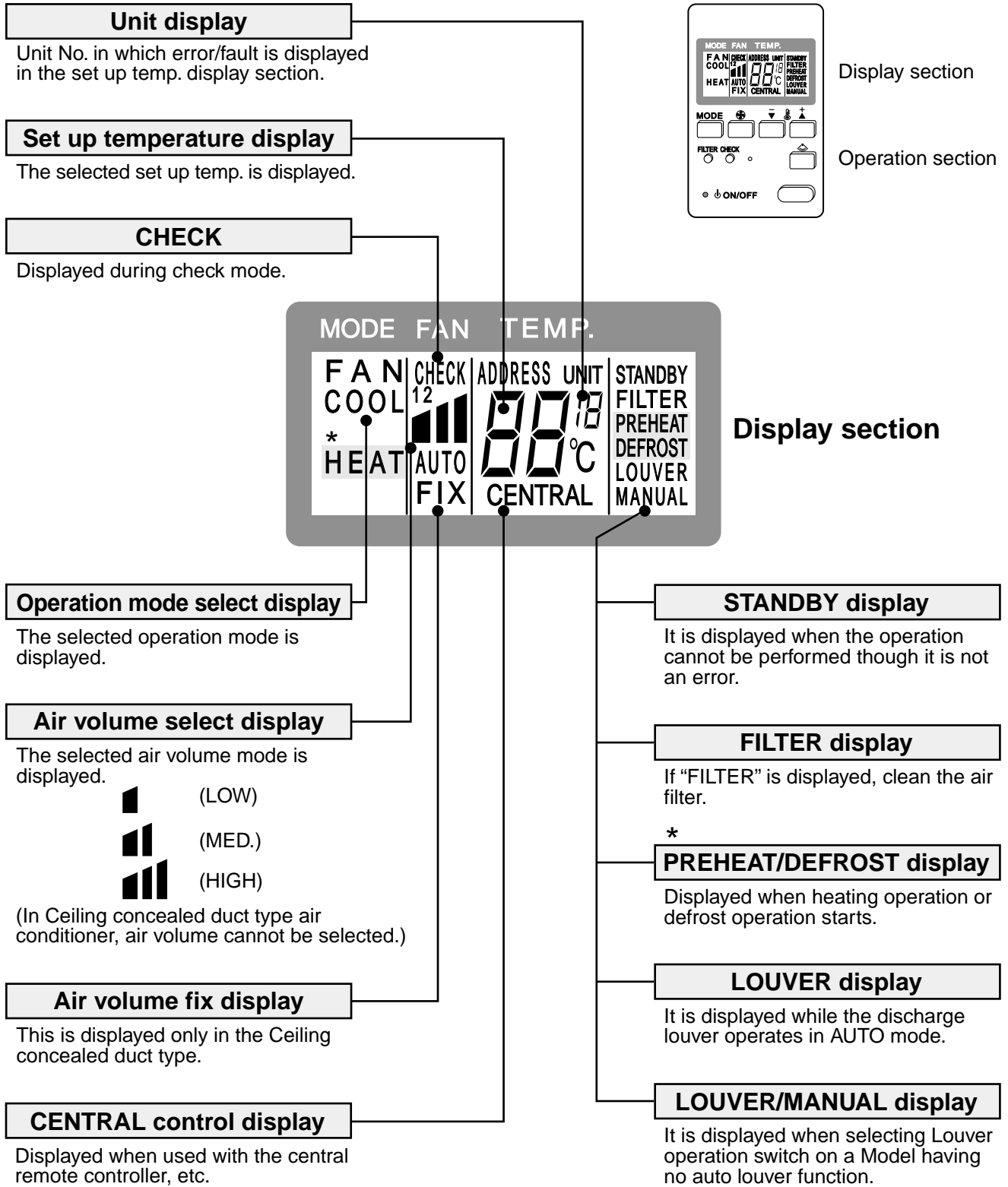

* They are displayed on the Heat Pump model only.

3-2-2-2. Operation section

Push each switch to select a desired operation.

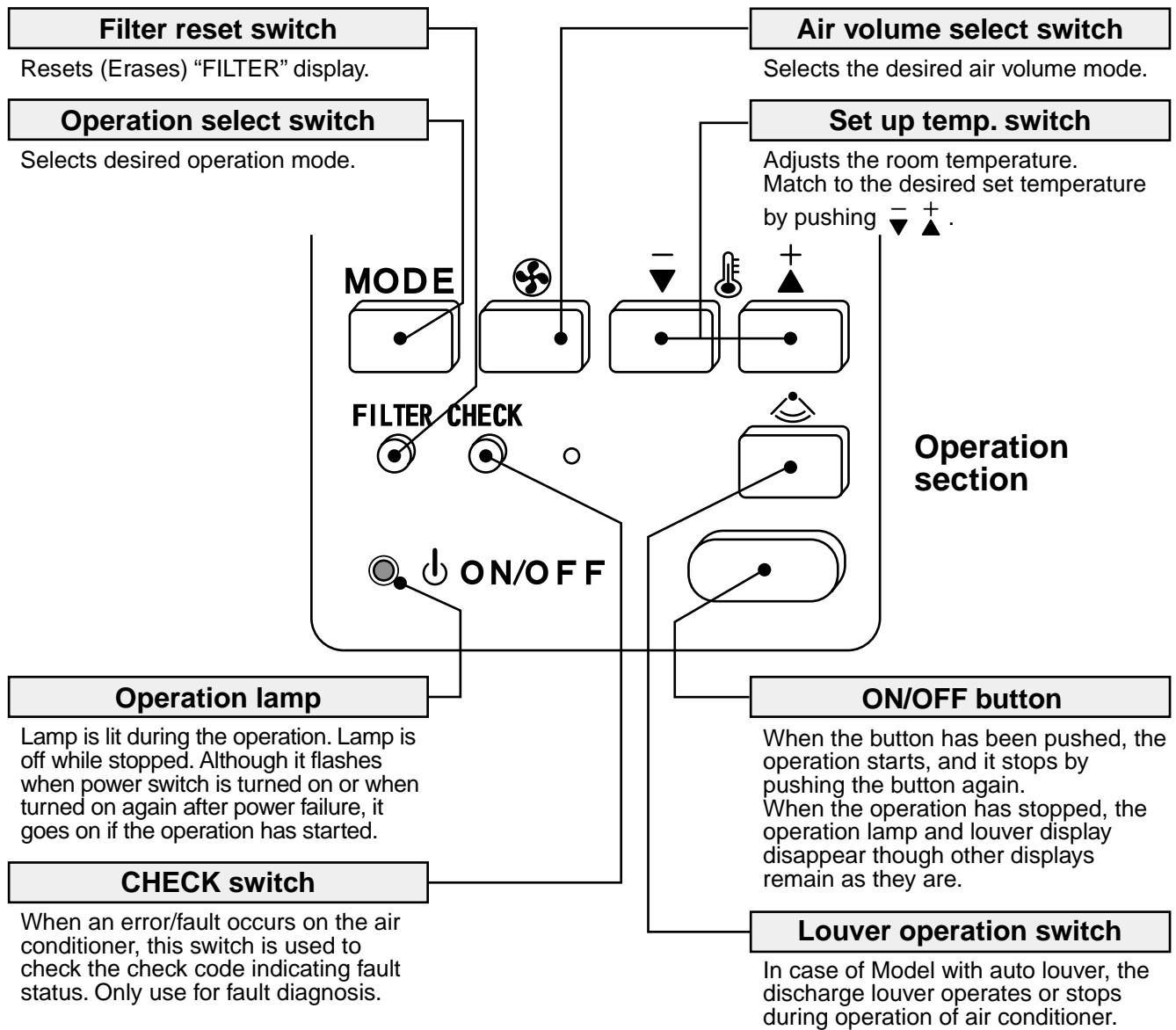

"Central indication"

When using a remote controller combined with a central remote controller, etc., contents which can be operated with the standard remote controller and "CENTRAL" display change by setting at the central remote controller.

Set up on central remote controller	"CENTRAL" display on standard remote controller	Functions operated by standard remote controller
Last-push priority (No display)	Goes off	Operated from both standard remote controller and central remote controller, and operated with contents specified later.
Center	Goes on	ON / OFF only can be operated.
Operation inhibit	Flashes	Operation not permissible.

For application control using "Weekly timer" or "Central remote controller" other than this standard remote controller, refer to the Manual attached to each remote controller.

3-2-3. Correct Usage

When you use the air conditioner at the first time or when you change the set up value, follow the procedure below. From the next time, the operation dis-played on the remote controller will start only by pushing ON/OFF button.

Preparation

Turn on the power switch.

- The operation lamp (Red) flashes.

REQUIREMENT

- While using the air conditioner, operate it only with ON/OFF button without turning off the main power switch.
- When starting the operation after stop for a long time, turn on the main power switch for 12 hours or more before start. (This is required because it is necessary to turn on the compressor case heater for heating in order to prevent overload on the compressor when activating the outdoor unit.)

1 Select an operation mode with the “MODE” button.

One push of the button, and the display changes as follows:

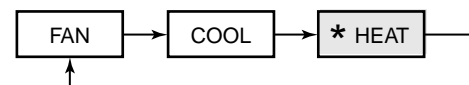

2 Select air volume with the “FAN” button.

One push of the button, and the display changes as follows:

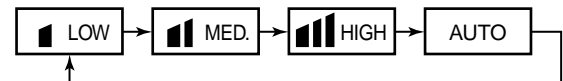

(Air volume cannot be selected in the concealed duct type.)

- When air volume is “AUTO”, power of air differs according to the room temperature.

3 Determine the set up temperature by pushing the “TEMP.” \downarrow \uparrow button.

4 Push “ON/OFF” button.

The operation lamp goes on, and the operation starts.

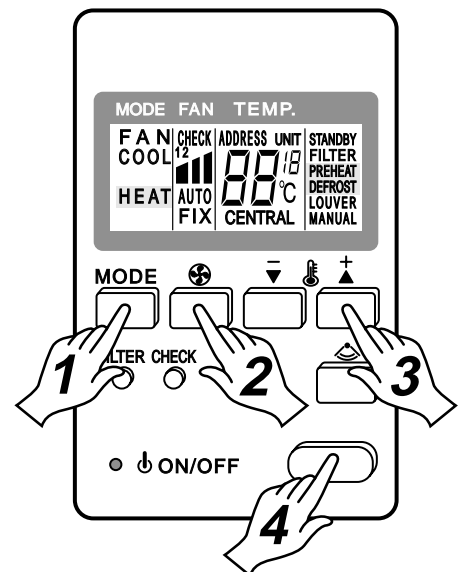

STOP

Push “ON/OFF” button.

The operation lamp goes off, and the operation stops.

- * “HEAT” is displayed on the Heat Pump model only.

NOTE

In cooling

- When the operation button has been pushed, the operation starts approx. 1minute after.

In heating

- When the operation button has been pushed, the indoor fan performs pre-heating operation for 3 to 5 minutes as it stops and then blows out hot air.
- While the room temperature has attained the set temperature and the outdoor unit stops, the super-low air blows out and air volume becomes excessively small. During defrost operation, the fan stops so that cold air does not blow out, and “PRE-HEAT” and “DEFROST” are displayed.

When restarting the operation after stop

In heating operation, the fan operation may continue for approx. 30 seconds after the machine has stopped.

- When restarting the operation immediately after stop, the air conditioner does not operate for approx. 3 minutes to protect the machine.

3-2-4. Maintenance

For maintenance, be sure to turn off the power switch.

<Daily maintenance>

◆ Cleaning of air filter

[4-way Air Discharge Cassette Type]

The suction port opens by pushing the “clips” of the suction port laterally.

Push up clip of the air filter, and take out the air filter by pulling it towards you.

[2-way Air Discharge Cassette Type]

- Pull the center panel toward you while lifting up it, and pull it slowly downward. (The center panel moves to either left or right only, so confirm before removing.)
- Remove the fall-preventing strings at both ends.
- Pull the air filter downward to remove it. In case of MMU-P0361WH or MMU-P0481WH, pull the air filter downward undoing the clips.

⚠ CAUTION

Be sure to attach the fall-preventing strings of the center panel after cleaning. If the center panel drops injury may occur.

[1-way Air Discharge Cassette Type]

- Undo clip of the suction port with both hands, open it slowly downward, push the air filter to inside to remove it from clips, and then remove the air filter.

(MMU-P0091SH and P0121SH model)

- Push clips at the center and left/right of the suction port to open the suction port.
- Lift up the air filter once, and pull it downward to remove it.

[Concealed Duct Type]

[Concealed Duct High Static Pressure Type]

- Cleaning method differs according to the installed air filter type.

Check with person who worked for installation or the dealer which you purchased it.

[Under Ceiling Type]

Pull the air filter towards you to take out it.

[High Wall Type]

- Push the projection at the center of air filter. Clip is out.
- Undo the clip of air filter, pull the air filter downward while pushing it toward the main unit side.

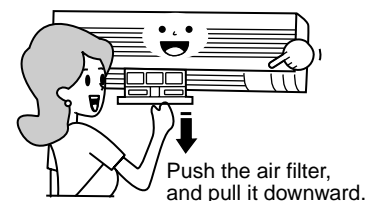
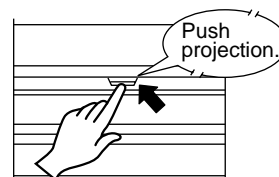
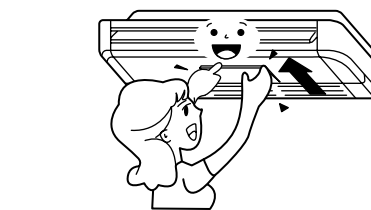
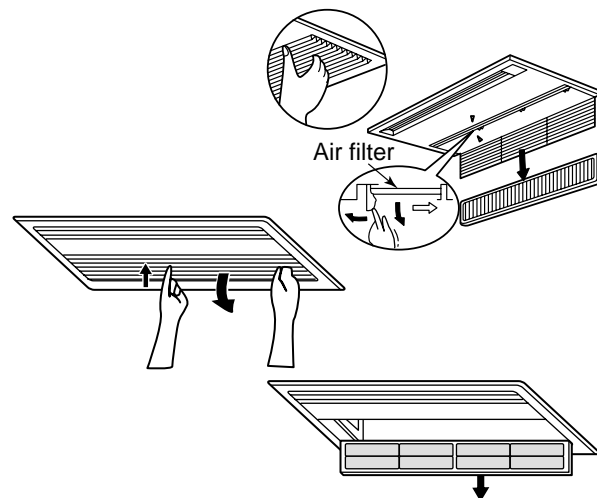
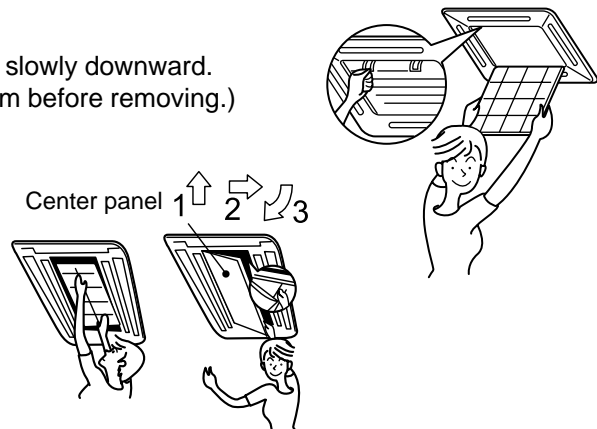
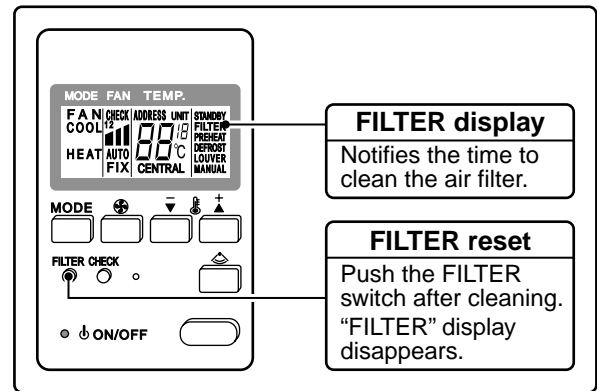

[Floor Standing Cabinet Type]

- Pull down the upper part of suction port a little, pull it toward you and remove it, and then take out the air filter inside of the unit.

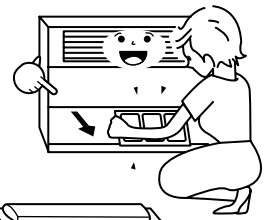

[Floor Standing Concealed Type]

- Pull down the air filter clip at the lower front panel, and take out the air filter by pulling it toward you.

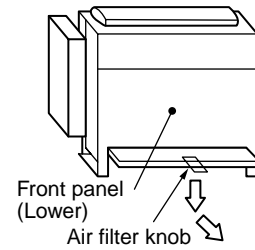

NOTE

- For cleaning of air filter, use a cleaner or brush clean. If stain is heavy, it is effective to wash the air filter in tepid water mixed with neutral detergent.
- After washing, rinse it well, and dry it in the shade.
- Install again the air filter which has been cleaned.

REQUIREMENT

- Insert the air filter until it stops securely.



■ Cleaning of main unit/remote controller

- Wipe them with soft and dry cloth.
- If stain of the main unit is heavy, wipe out stain with cloth wet in tepid water. (For remote control, wipe outstain with dry cloth without using water.)
- Do not use benzene, thinner, polishing powder, or chemical floor-cloth because they may cause deformation or crack on the panel or remote controller.

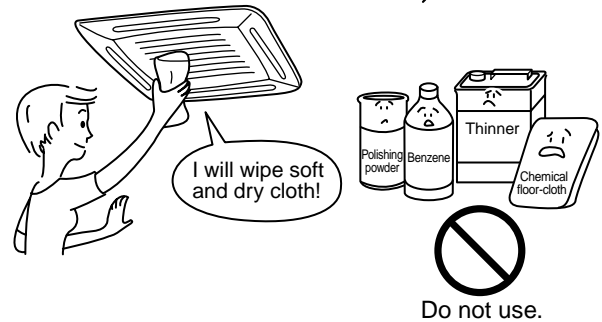

<When the air conditioner is not used for a month or longer>

- Perform fan operation for half a day to dry inside of air conditioner well.
- Turn off the power switch.
- Clean the air filter, and attach it again as it was before.

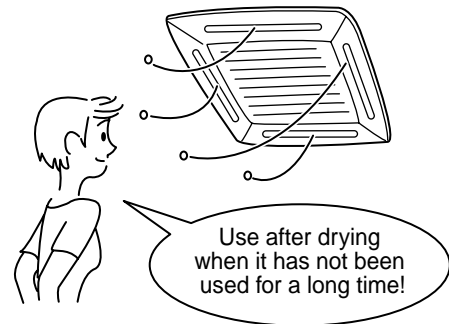

<Before season to use cooling function>

(Concealed duct high static pressure type, Floor standing concealed type)

Cleaning of drain pan and drain receiver (with strainer)

⚠ CAUTION

Clean drain pan or drain receiver (strainer).

If garbage is clogged in drain pan or drain receiver, water may flood resulted in damp on the ceiling or floor.

“Drain receiver (strainer) is provided to Floor standing concealed type only.”

REQUIREMENT

For cleaning of drain pan and drain receiver, contact the dealer which you have purchased the air conditioner.

3-2-5. How to Use the Air Conditioner Effectively

For saving of electric cost and comfortable cooling or heating operation.

■ **Diligent cleaning of air filter**

- If the air filter is clogged, cooling/ heating effect decreases.

■ **Close windows and doors often**

- Close windows and doors so that cool air does not blow through the room.

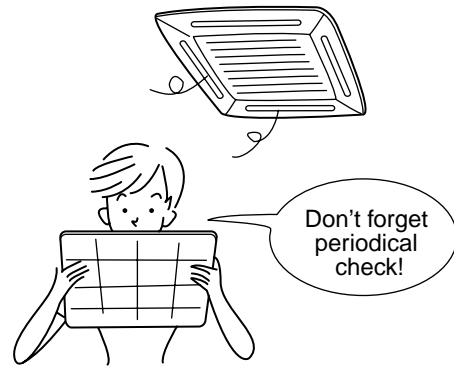

⚠ WARNING

Do not expose your body directly in cool air for a long time.

- It may affect the health. Especially, be watchful for person physically handicapped, children, or senior person.

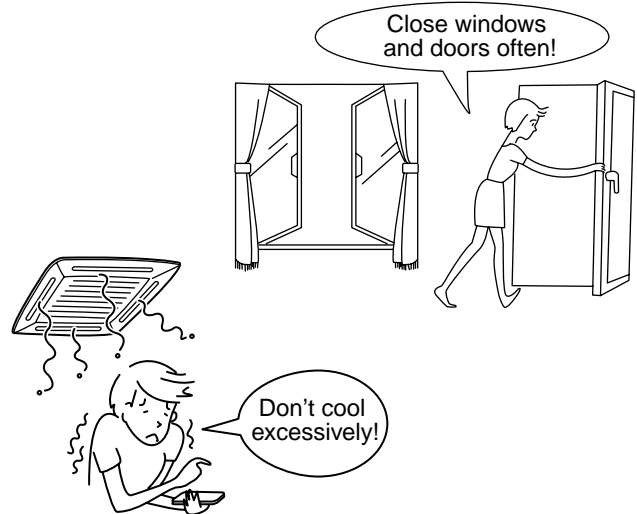

■ **Room temperature without unevenness**

- Adjust the air direction with discharge louver. If you expose yourself in the air flow for a long time, it may affect your health.

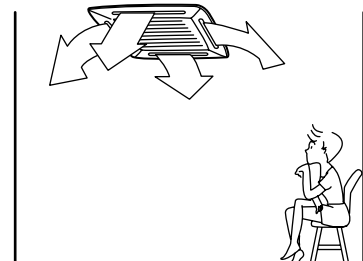



For using the air conditioner effectively, operate it under the following conditions.

Cooling operation	Outdoor temperature	-5°C or more, 43°C or less
	Indoor temperature	21°C or more, 32°C or less
	Indoor humidity	80% or less If the air conditioner operates with humidity exceeding 80%, dew adhered to surface of the panel may fall, or dew may be sprayed from the discharge grille.
Heating operation	Outdoor temperature	-15°C or more, 21°C or less
	Indoor temperature	28°C or less

If the air conditioner is operated under conditions other than these conditions, a protective device works and the operation may become unavailable.

3-2-6. When the Following Symptoms are Found

Check the points described below before asking repair servicing.

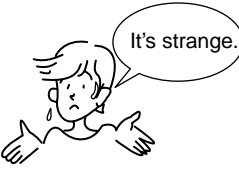
Symptom		Cause
It is not a failure. 	Outdoor unit <ul style="list-style-type: none"> • White misty cold air or water is out. • Sometimes, noise "Pushu!" is heard. 	<ul style="list-style-type: none"> • Fan of the outdoor unit stops automatically and performs defrost operation. • Solenoid valve works when defrost operation starts or finishes.
	Indoor unit <ul style="list-style-type: none"> • "Swish" sound is heard sometimes. • Slight "Pishi!" sound is heard. • Discharge air smells. • The operation lamp flashes • "STANDBY" indication is lit. • Sound or cool air is output from the stand by indoor unit. • When power of the air conditioner is turned on, "Ticktock" sound is heard. 	<ul style="list-style-type: none"> • When the operation has started, during the operation, or immediately after the operation has stopped, a sound such as water flows may be heard, and the operation sound may become larger for 2 or 3 minutes immediately after the operation has started. They are flowing sound of refrigerant or draining sound of dehumidifier. • This is sound generated when heat exchanger, etc. expand and contract slightly due to change of temperature. • Various smell such as one of wall, carpet, clothes, cigarette, or cosmetics adhere to the air conditioner. • Flashes when power is turned on again after power failure, or when power switch is turned on. • When cooling operation cannot be performed because another indoor unit performs heating operation. • When the manager of the air conditioner has fixed the operation to COOL or HEAT, and an operation contrary to the setup operation is performed. • When fan operation stopped to prevent discharge of hot air. • Since refrigerant is flowed temporarily to prevent stay of oil or refrigerant in the stand by indoor unit, sound of flowing refrigerant, "Kyururu" or "Shaa" may be heard or white steam when other indoor unit operates in HEAT mode, and cold air in COOL mode may be blow-out. • Sound is generated when the expansion valve operates when power has been turned on.
Check again.	Operates or stops automatically.	<ul style="list-style-type: none"> • Is the timer "ON" or "OFF"?
	Does not operate. 	<ul style="list-style-type: none"> • Is it a power failure? • Is the power switch turned off? • Is the power fuse or breaker blown? • Has the protective device operated? (The operation lamp goes on.) • Is the timer "ON"? (The operation lamp goes on.) • Are COOL and HEAT selected simultaneously? ("STANDBY" indication is lit on the display column of the remote controller.)
	Air is not cooled or warmed sufficiently. 	<ul style="list-style-type: none"> • Is the suction port or discharge port of the outdoor unit obstructed? • Are any door or window open? • Is the air filter clogged with dust? • Is discharge louver of the indoor unit set at appropriate position? • Is air selection set to "LOW" "MED", and is the operation mode set to "FAN"? • Is the setup temp. the appropriate temperature? • Are COOL and HEAT selected simultaneously? ("STANDBY" indication is lit on the display column of the remote controller.)

When the following symptoms are found, stop the operation immediately, turn off the power switch, and contact the dealer which you have purchased the air conditioner.

- Activation of switch is unstable.
- Fuse or breaker is blown periodically.
- Foreign matters or water entered by mistake.
- When if activation cause of the protective device has been removed, the operation is not performed.
- Other unusual status occurred.

3-2-7. Confirmation and Check

■ Confirmation of check No.

When an error/fault occur on the air conditioner, the check No. indicating the defective status can be confirmed by the CHECK switch on the remote controller.

Before requesting repair, confirm the check No. in the following procedure, and contact the dealer with symptom of the air conditioner.

[Confirmation procedure]

1. Hold the CHECK switch on the remote controller for 1 or 2 seconds. The "CHECK" display appears, and the unit No. and check No. are displayed in the display section of set up TEMP.
2. The unit No. represents the number of indoor unit in which an error occurred.
3. Check No. is displayed as follows.

- When an error/fault does not occur.

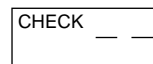

- When one error/fault occurs.

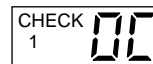

- When two error/fault occur.

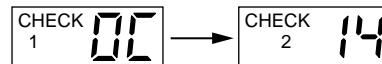

If you could not read the display sufficiently, push CHECK switch again.

■ Check servicing

- Though differed according to use status, when the air conditioner has been used for several seasons, inside of the air conditioner may be stained, and performance may decrease. Separated from daily maintenance, a check servicing (charged) is recommended.
- The Ceiling cassette type air conditioner incorporates a drain pump. If it is used in an oily and dusty place, the pump can be blocked causing the water drain to disable. It is required to clean the pump periodically. For cleaning of drain pump, contact the dealer. (When a drain-up kit is attached to concealed duct type and under ceiling type are same precautions are recommended.)

3-2-8. Accessories Sold Separately

⚠ WARNING

When you require accessory or parts, consult us.

Be sure to use the products sold separately which are specified by us.

If using other products than those specified, a fire, electric shock or water leakage may be caused.

For installation, ask a special engineer.

3-3. REFRIGERANT PIPING SYSTEMATIC DRAWING

Inverter unit (10HP, 8HP)

Cooling Only model : MMY-MP0801T8, MP1001T8

Heat Pump model : MMY-MP0801HT8, MP1001HT8

: MMY-MP0801HT7, MP1001HT7

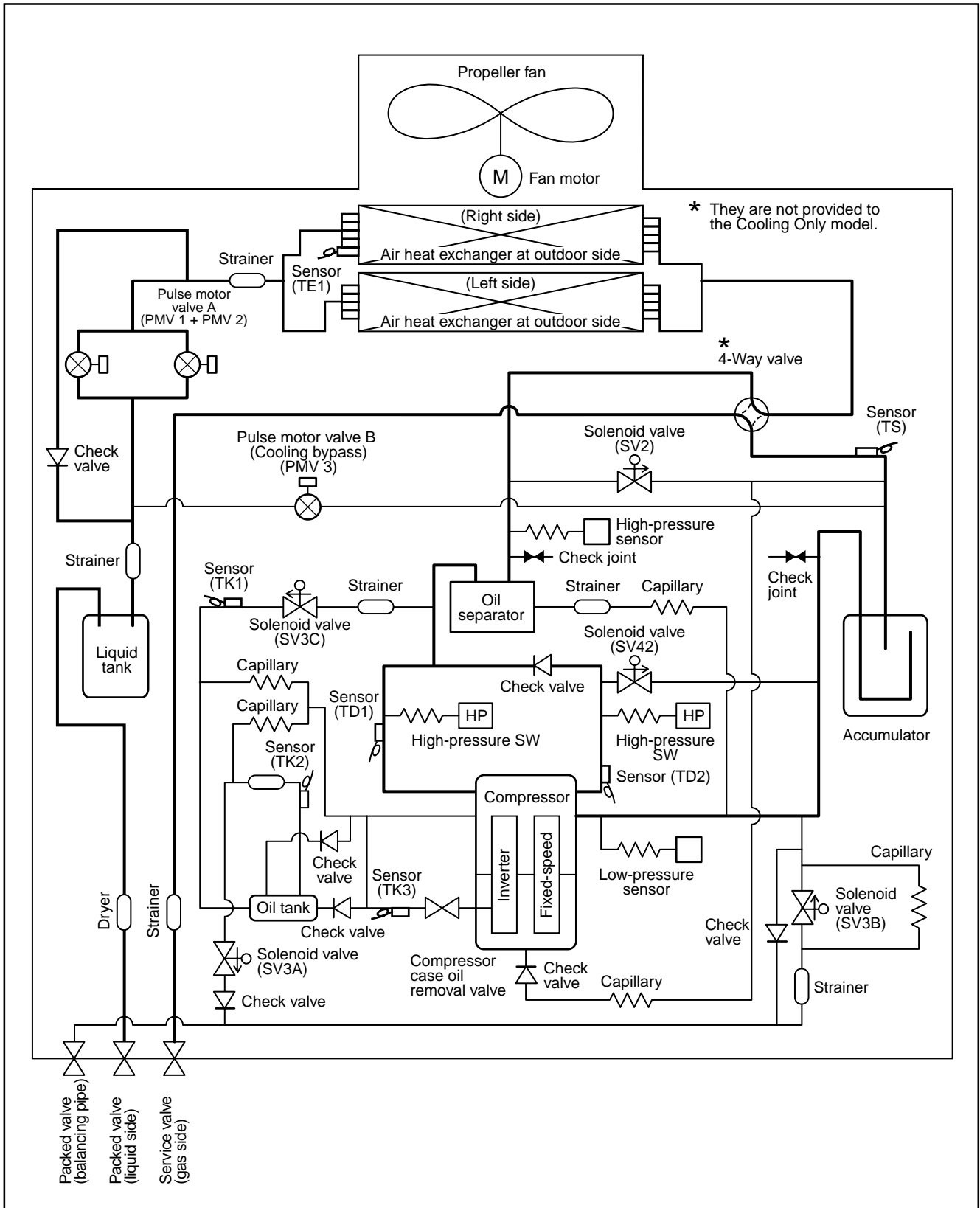

Fixed-speed unit (10HP, 8HP)

Cooling Only model : **MMY-MP08018, MP10018**

Heat Pump model : **MMY-MP0801H8, MP1001H8**

: **MMY-MP0801H7, MP1001H7**

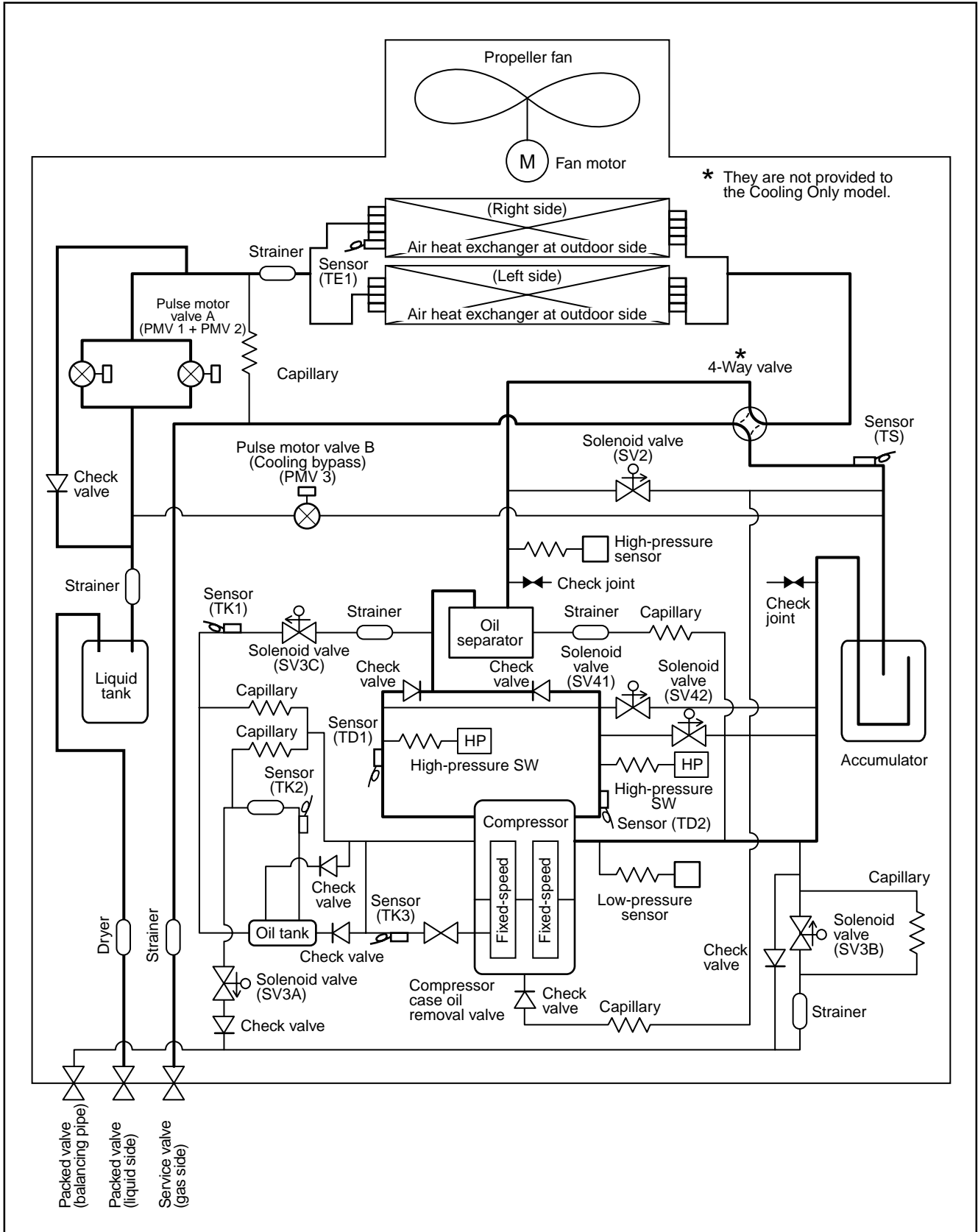

Fixed-speed unit (6HP)

Cooling Only model : **MMY-MP06018**

Heat Pump model : **MMY-MP0601H8**

: **MMY-MP0601H7**

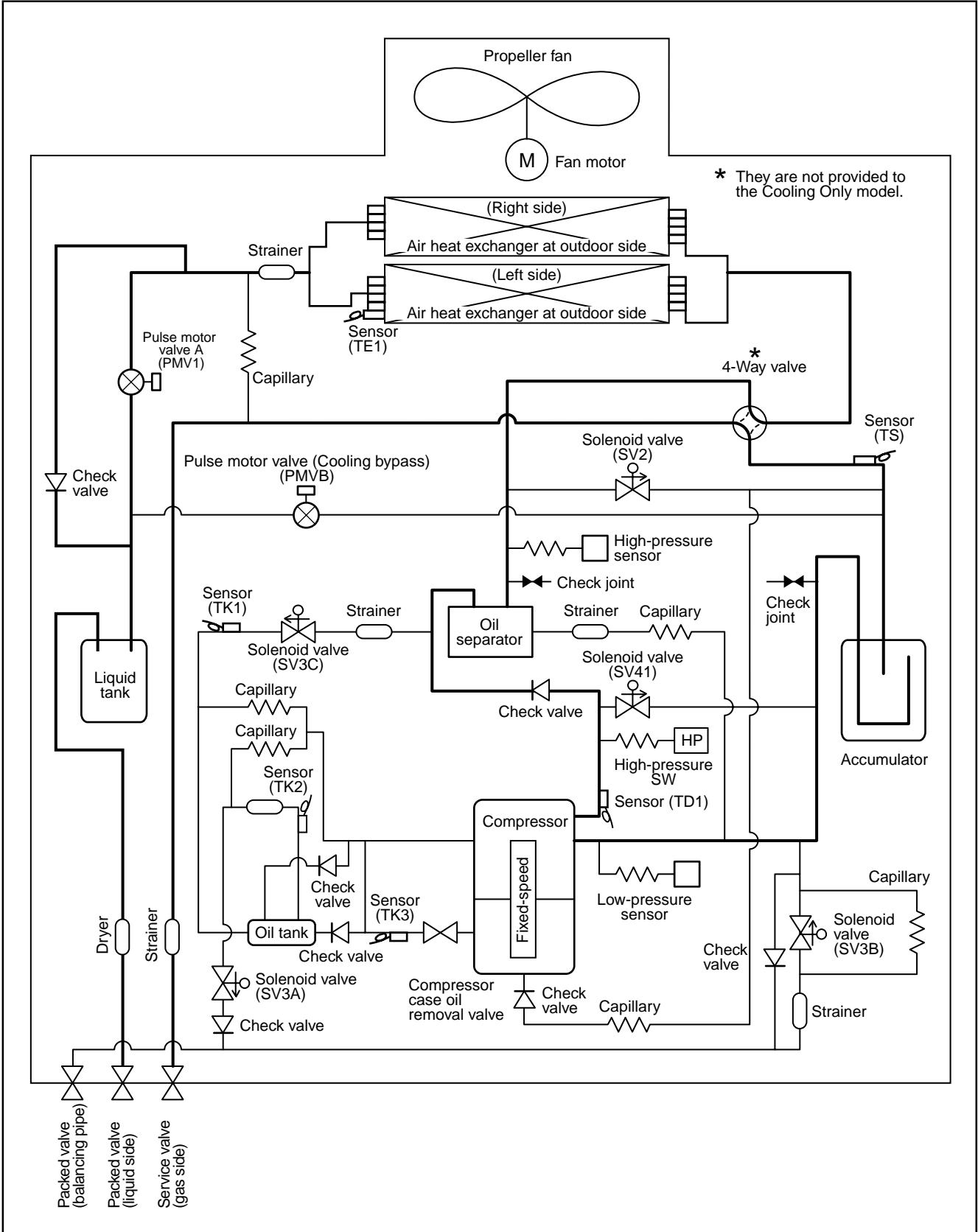

Explanation of functional parts

Functional part	Functional outline		
Solenoid valve	1. SV3A	1) Gathers oil in the compressor case to the oil tank of compressor during OFF time. 2) Supplies the gathered oil to the balancing pipe during ON time when pressure is applied to inside of the oil tank. 3) Supplies oil in the case directly to the balancing pipe when pressure is applied to inside of the compressor case. 4) Reduces pressure after pressure has been applied to inside of the oil tank	
	2. SV3B	1) Returns oil supplied in the balancing pipe to the compressor.	
	3. SV3C	1) Applies pressure to inside of the oil tank during ON time. 2) Detects oil level with temp. system.	
	4. SV2	(Hot gas bypass) 1) Low-pressure release valve (To protect lowering of low pressure which is difficult to activating time of Modular multi type) 2) Protects liquid refrigerant gathering in accumulator. 3) Gas balancing in STOP time.	(Compressor case bypass) 1) Stirs oil to prevent oil separation into two layers.
	5. SV4 (n)	(Activation compensating valve for fixed-speed compressor) 1) For activation of gas balance 2) Deflates gas in discharge pipe. (Protects liquid stagnation in discharge pipe.)	
Check valve	Check valve for discharge	1) Protects counter pressure when the inverter compressor is operating and the constant speed compressor stops. 2) Decreases activation load when fixed-speed compressor is activated. (Shared function with SV4 (n) valve)	
	Check valve for liquid line	Prevents liquid accumulation in heat exchanger of the stopped outdoor unit. * It is provided to the Cooling Only model only.	
Pulse motor valve	1. PMV A (Two pcs. used) (PMV1 + PMV 2)	(Connector CN300, 301 : White) * It is provided to the Heat Pump model only. 1) Control function for super heat volume in heating operation (Refrigerant split flow between outdoor units) 2) Liquid line shut-down function while the fixed-speed units stop 3) Liquid line counter-pressure preventive control function during defrost operation 4) Fixed with FULL OPEN in cooling operation.	
	2. PMVB (PMV3)	(Cooling bypass) (Connector CN302 Red) 1) Liquid bypass proportional control function for releasing discharge temperature (Adjustment of refrigerant drying degree during inner reducing operation) 2) Releases low pressure.	
Oil separator	1) Early protection of oil level down (Decreases flow-out of discharge oil to cycle)		
Temp. sensor	1. TD1 TD2	(TD1 : Connector: Red, TD2 : Connector: White) 1) Used to protect discharge temperature of the compressor. 2) Used to control cooling bypass for releasing discharge temperature.	
	2. TS1	(Connector: White) 1) Used to control super heat of PMV in heating operation. 2) Used to control cooling bypass for releasing discharge temperature.	
	3. TK1 TK2 TK3	(TK1 : Connector: Black, TK2 : Connector: Blue, TK3 : Connector: Green) 1) Used to detect oil level judgment. (TH1, TK2) 2) Used to detect dilution status of oil. (TK3)	
	4. TE1	(Connector : Blue) 1) Used to control the cooling fan. 2) Used to control defrost operation in heating operation. 3) Used to control the heating fan.	
Pressure sensor	1. High pressure sensor	(Connector : Red) 1) Used to detect high pressure, and compressor capacity. 2) In cooling operation, it is used to detect high pressure, and control the fan in cooling low ambient conditions.	
	2. Low pressure sensor	(Connector : Blue) 1) In cooling operation, it is used to detect low pressure, and control the capacity of the compressor. 2) In heating operation, it is used to detect low pressure and control super heat.	
Balancing pipe	1) Oil supply path for balancing oil of each outdoor unit. 2) Low-pressure bypass function between outdoor units, which recovers the liquid refrigerant stagnated in the stand by outdoor unit. 3) Low-pressure balancing pipe function to secure pressure difference when check valve of every outdoor units aligned on a circuit in parallel are inverted.		

3-4. COMBINED REFRIGERANT PIPING SYSTEMATIC DRAWING

3-4-1. Normal Operation

* They are not provided to the Cooling Only model.

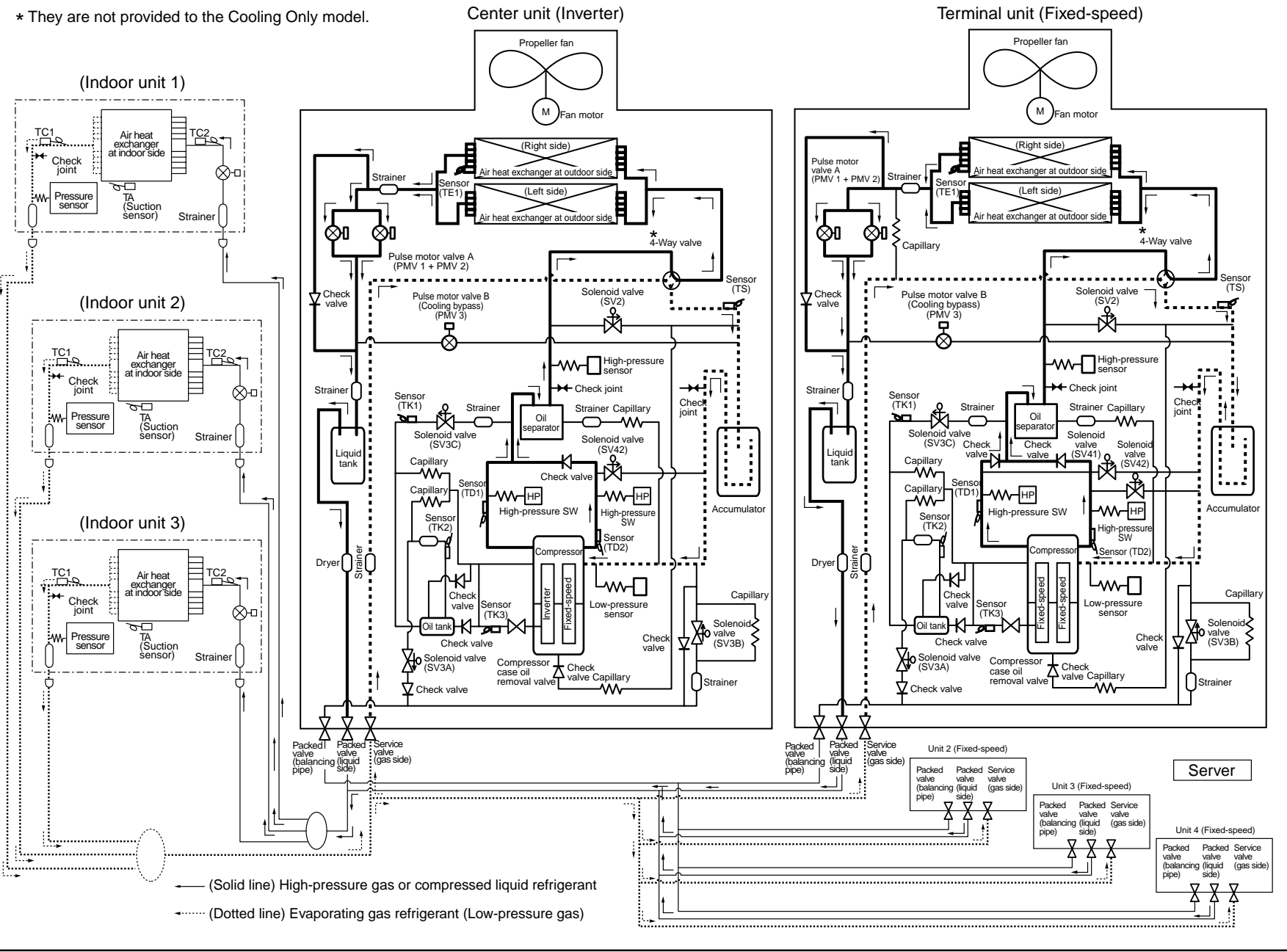

3-4-2. Emergent Operation When IPDU Unit is Failed (Master unit backup operation)

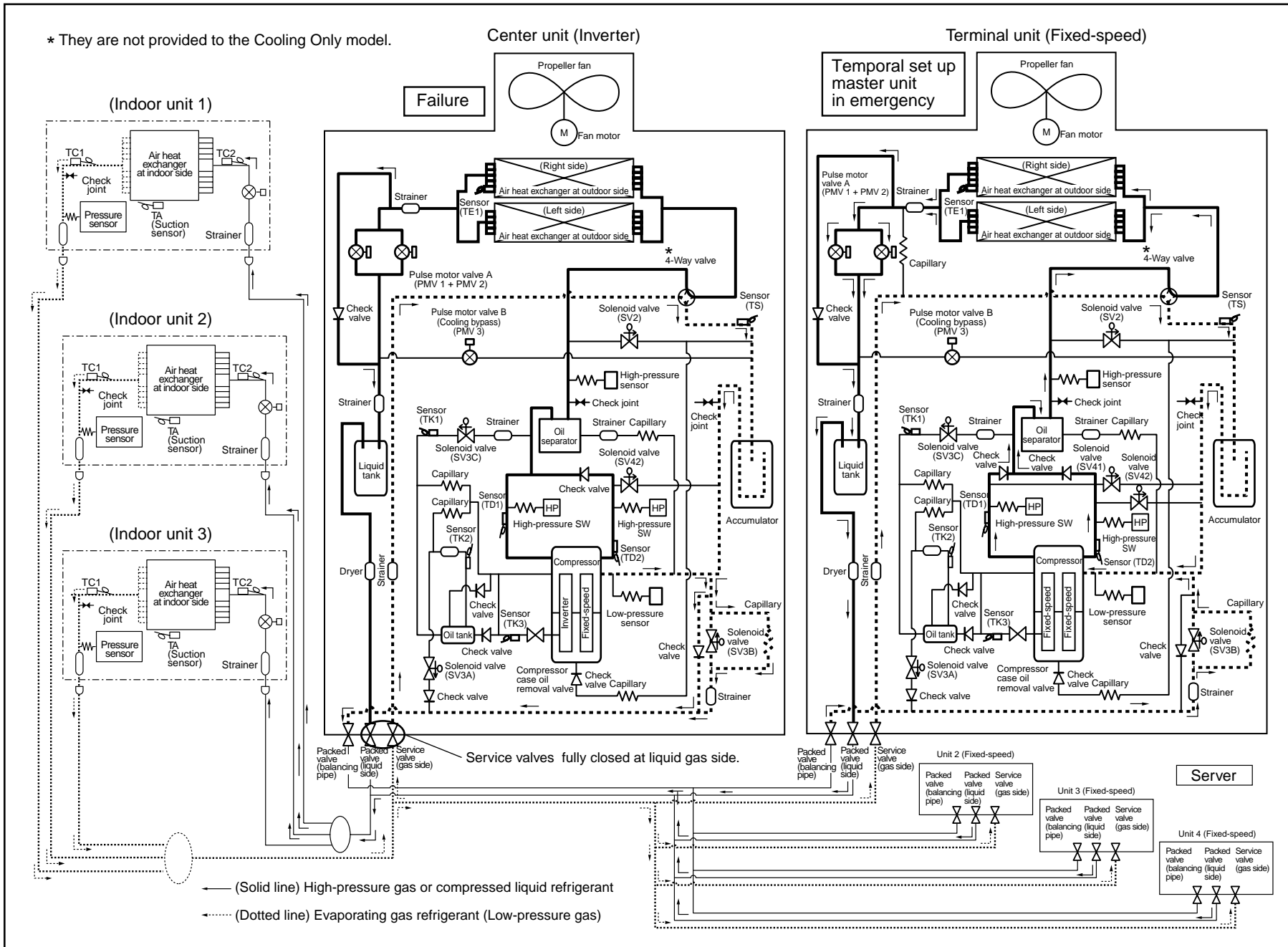

3-4-3. Emergent Operation When Fixed-Speed Unit is Failed

* They are not provided to the Cooling Only model.

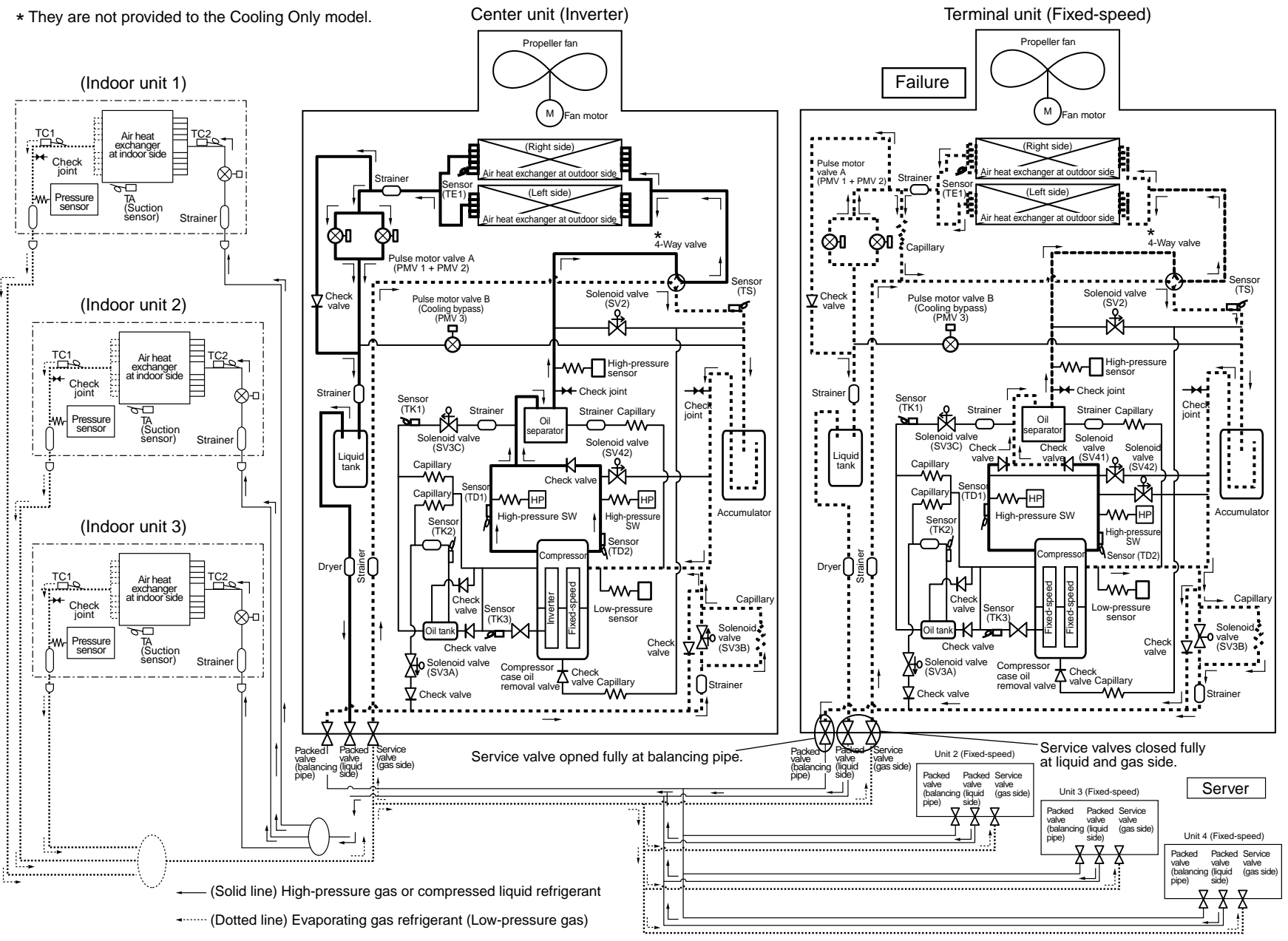

**3-4-4. Recovery of Refrigerant in Failed Outdoor Unit
(Normal outdoor unit recovers refrigerant)**

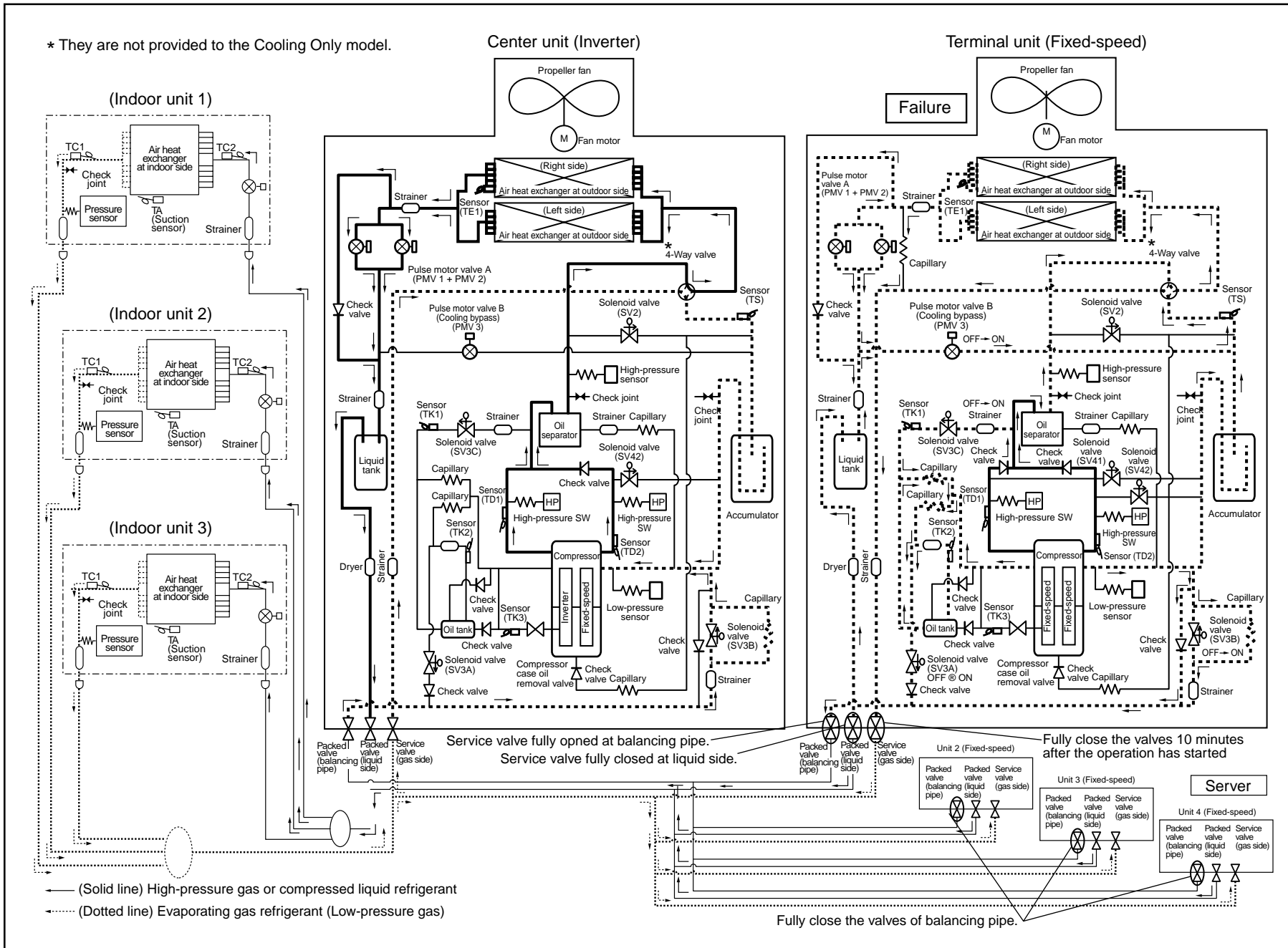

3-5. OUTLINE OF CONTROL

3-5-1. Outdoor Unit

3-5-1-1. Operation start/Operation end

The compressor, solenoid valve, pulse motor valve (PMV A), outdoor fan, etc. are controlled by a command from the indoor controller. The server outdoor unit starts/stops by a command from the master outdoor unit.

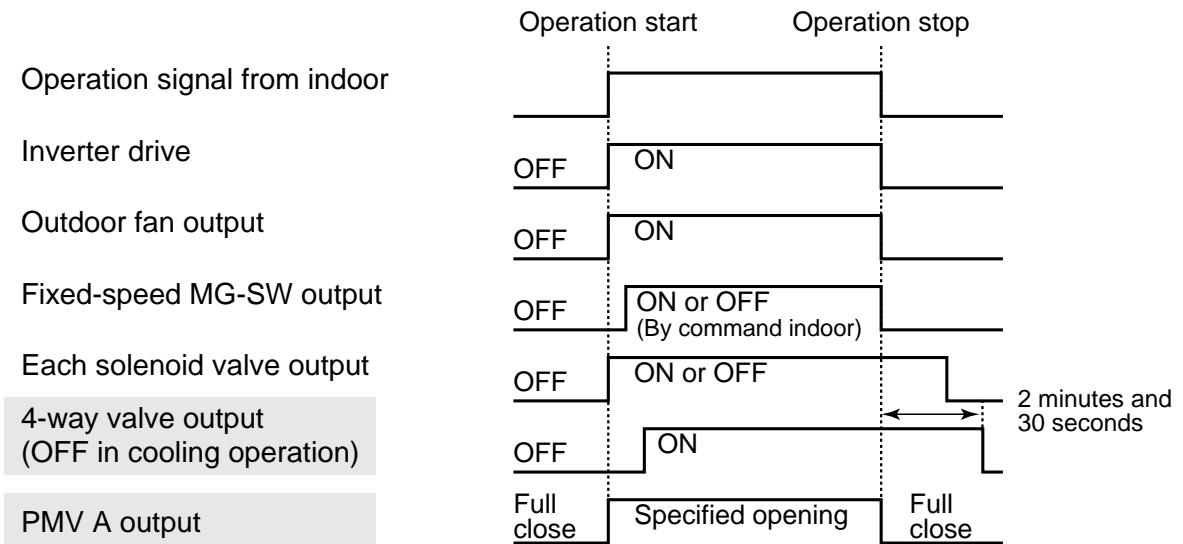

3-5-1-2. Thermostat ON/Thermostat OFF

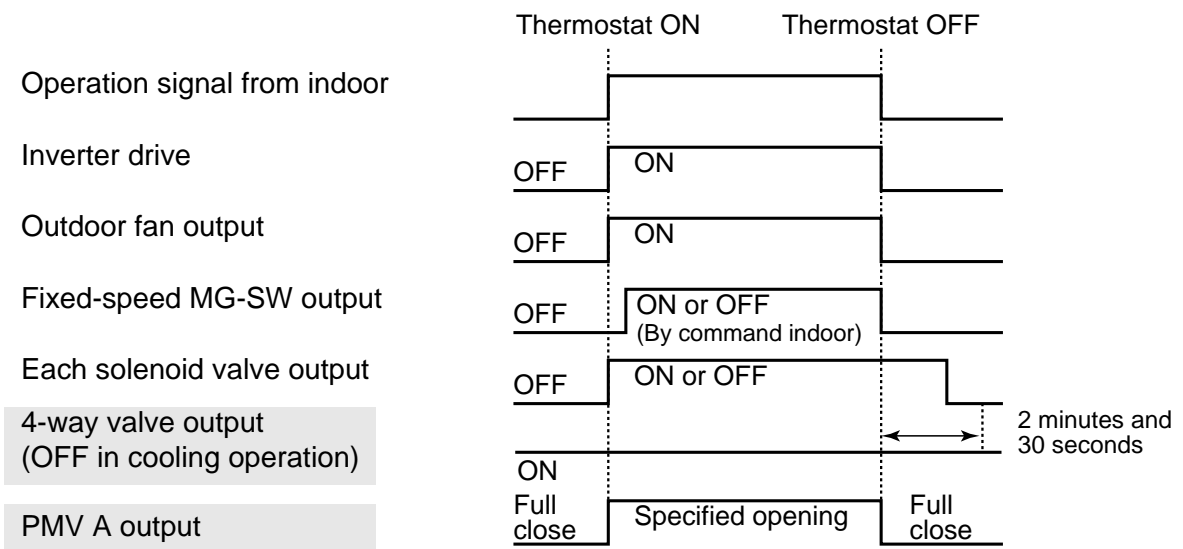

3-5-1-3. Outline of main controls

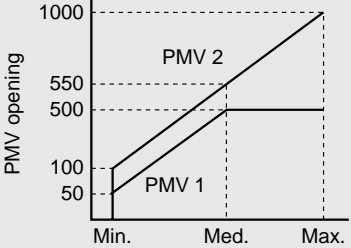
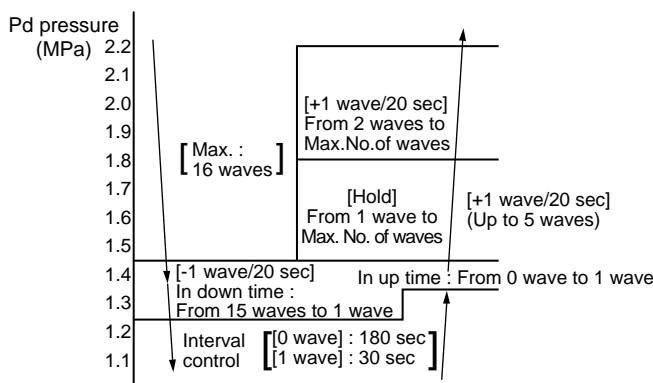
Item	Operation explanation and applied data, etc.	Remarks
<p>1. Pulse motor valve (PMV A, B) control</p>	<p>(1) PMV A (PMV 1, PMV 2) control (using two PMV)</p> <ol style="list-style-type: none"> 1) PMV (Pulse Motor Valve) is controlled between 100 to 1000 pulses during operation. 2) In cooling operation, PMV 1, PMV 2 are fixed with FULL OPEN status. (PMV 1 = 500 pulses, PMV 2 = 500 pulses) 3) In heating operation, PMV opening is controlled by detection temperature of TS and TD sensors and detection value of PS pressure. (Super Heat control) 4) Close fully PMV opening when thermostat is OFF, operation stops, and the A.C. stops in trouble.  <p>(2) PMV B (PMV 3) control</p> <p>The purpose of PMV B control is to control the liquid refrigerant bypass for suppressing discharge temp. increase or compressor internal temp. increase.</p> <ol style="list-style-type: none"> 1) Opening is controlled with pulses from 0 to 500. 2) PMV opening is controlled with temp. detected by TS/TD sensors. 3) PMV openings are fully closed during thermostat-OFF, operation stop, and emergency stop. 	
<p>2. Outdoor fan control</p>	<p>(1) Cooling fan control</p> <ol style="list-style-type: none"> 1) Outdoor fan speed (No. of fan driving waves) is controlled by Pd pressure detection value. 2) In a specified time when cooling operation is activated, the master outdoor unit controls the outdoor fan speed (No. of fan driving waves) by Pd pressure detection value. The server outdoor unit controls the outdoor fan speed (No. of fan driving waves) with temperature detected by TE sensor.  <p>* Cooling fan control controls No. of fan driving waves so that the detection value of Pd pressure becomes 1.45 to 1.8MPa. No. of waves can be controlled between 0 wave (STOP) to 16 waves (All waves).</p>	

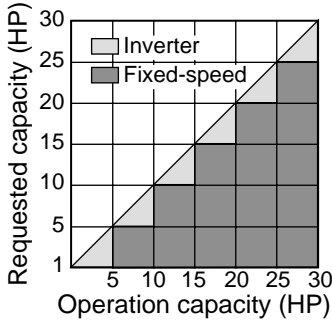
Item	Operation explanation and applied data, etc.	Remarks												
<p>2. Outdoor fan control (Continued)</p>	<p>(2) Heating fan control</p> <ol style="list-style-type: none"> 1) Outdoor fan speed (No. of fan driving waves) is controlled by TE sensor detection temperature. 2) If TE>20°C has been continuously detected for 5 minutes, the operation may be stopped. In this case, the status is same as one in usual thermostat-OFF, so restart the operation. 3) When the high-pressure switch operates frequently under condition of the above 2), it is considered that air filter of the indoor unit is contaminates. Clean the filter and restart the operation. 4) After activation, this control is not performed during the specified time after defrost operation and defrost control. 5) When refrigerant is extremely shortened, START/STOP operation may be repeated by this control. <p>TE temp. (°C)</p> <table border="1" style="width: 100%; border-collapse: collapse;"> <tr> <td style="width: 20px; text-align: center;">20</td> <td>A zone : No. of lower limit waves, Compressor forced stop timer count</td> </tr> <tr> <td style="text-align: center;">6</td> <td>B zone : -2 waves/20 sec (up to No. of lower limit waves)</td> </tr> <tr> <td style="text-align: center;">4</td> <td>C zone : -1 waves/20 sec (up to No. of lower limit waves)</td> </tr> <tr> <td style="text-align: center;">2</td> <td>D zone : Hold (Held at the current No. of waves)</td> </tr> <tr> <td style="text-align: center;">1</td> <td>E zone : +1 waves/20 sec (up to Max. No. of waves)</td> </tr> <tr> <td style="text-align: center;">1</td> <td>F zone : Max. No. of waves (16 waves)</td> </tr> </table> <p>(3) Control for fixed-speed unit stop</p> <p>The fan is driven with 1 wave to prevent stagnation of refrigerant into the outdoor heat exchanger.</p>	20	A zone : No. of lower limit waves, Compressor forced stop timer count	6	B zone : -2 waves/20 sec (up to No. of lower limit waves)	4	C zone : -1 waves/20 sec (up to No. of lower limit waves)	2	D zone : Hold (Held at the current No. of waves)	1	E zone : +1 waves/20 sec (up to Max. No. of waves)	1	F zone : Max. No. of waves (16 waves)	
20	A zone : No. of lower limit waves, Compressor forced stop timer count													
6	B zone : -2 waves/20 sec (up to No. of lower limit waves)													
4	C zone : -1 waves/20 sec (up to No. of lower limit waves)													
2	D zone : Hold (Held at the current No. of waves)													
1	E zone : +1 waves/20 sec (up to Max. No. of waves)													
1	F zone : Max. No. of waves (16 waves)													
<p>3. Capacity calculation</p>	<p>By the capacity request command from the indoor controller, the inverter operation command of the master outdoor unit, ON/OFF control of the fixed-speed compressor and the server outdoor unit are determined. The master outdoor unit sets up activation priority order of the server outdoor units connected to the system, and starts the operation.</p> <p><Example of 30HP system></p> 													
<p>4. Oil level detection control</p>	<ol style="list-style-type: none"> 1) The volume of oil in the oil tank is judged by the detection temperature of TK1 and TK2 sensors. 2) The present temperature detected by TK1, TK2 and TK3 sensors are stored in memory as the initial value, and then on the solenoid valve SV3C is activated. <p>After then, execute sampling of TK1, TK2 and TK3 sensor temperature, and obtain the temperature change value of TK1 and TK2. Also, whether the oil level is adequate or not is judged from relation between the set up oil level judgment time and the above temp. change value, and the operation transmits to the oil equalizing control if oil is reduced.</p>													

Item	Operation explanation and applied data, etc.	Remarks
5. Oil equalizing control	<p>This control is to prevent oil reduction in the compressor between the outdoor units. This control is classified into two, one is an individual control in a normal operation which is performed by the master outdoor unit, and the other is a system control which is executed when shortage has been detected in the oil level detection control. Basically, this control is executed by open/close operation of solenoid valves SV3A, SV3B, and SV3C, and has the following three patterns.</p> <p>(1) Oil equalizing control 1 This is executed when the master outdoor unit has continuously operated for 30 minutes or more, and the result of the oil level detection judgment has been adequate. If only one master outdoor unit is provided (when no server outdoor unit is not connected), this control is not implemented.</p> <p>(2) Oil equalizing control 2 This is executed to supply oil collected in the oil tank of each outdoor unit to the outdoor unit of which oil level has been reduced. When the oil level judgment result of the master outdoor unit has been insufficient while the compressor of master outdoor unit was ON, or when even one of the server outdoor units required oil equalizing, this control is implemented. When only one master outdoor unit is provided, this control is not implemented.</p> <p>(3) Oil equalizing control 3 This is executed when the oil level has not been appropriate even if the oil equalizing control 2 was executed. However, it is not executed in 1 unit system of the master outdoor unit.</p>	<ul style="list-style-type: none"> • Controls so that oil is gathered in the inverter with high operation ratio. • Normal oil equalizing operation. • The last oil equalizing means to be used when the oil level down has been detected for a long time.
6. Refrigerant/Oil recovery control	<p>(1) Oil recovery control in cooling room During cooling operation, this is executed to recover the refrigerating oil stagnated in gas crossover pipe or indoor unit to the outdoor unit when the compressor driving command is small, and to prevent stagnation of refrigerant in the outdoor heat exchanger while low ambient cooling operation is performed. This control is managed by the master outdoor unit.</p> <p>1) Control conditions</p> <ul style="list-style-type: none"> • When compressor-ON status continued for 60 minutes. • When time of the cooling thermostat-OFF calculation timer has finished. <p>2) Contents of control After cooling operation has been activated, the cooling indoor oil recovery signal is sent to the indoor controller when the cooling thermostat-ON status continued for 60 minutes. The cooling thermostat-ON 60 minutes timer starts counting again. At the same time, the indoor PMV minimum opening signal is also sent to the indoor controller.</p> <p>(2) Refrigerant recovery control in heating room During heating operation, this is executed to recover liquid refrigerant stagnated in the stopped indoor unit. It is also used to recover oil in the outdoor heat exchanger in heating overload operation except with defrost condition.</p> <p>1) After heating operation has been activated, it is executed when thermostat is ON or the operation is shifted to the normal heating operation after defrost operation and compressor ON status continues for 60 minutes.</p> <p>2) While controlling refrigerant recovery in the heating room, the heating room refrigerant recovery signal is sent to the indoor controller for 10 minutes. According to the target operation command, it controls compressor capacity based upon each operation pattern at time of heating activation, time of heating operation, and finish time of defrost operation.</p>	<ul style="list-style-type: none"> • Recovery time : Approx. 2 min to 6 min though it differs according to the system capacity. • The recovery time differs according to the load condition. However, it is usually executed for 2 to 10 minutes.

Item	Operation explanation and applied data, etc.	Remarks
7. Defrost control (Reverse defrost method)	<p>(1) Start condition of defrost operation When 25 minutes has passed at the first time and 55 minutes at the second time and later after the compressor was activated, by counting the operation time when TE sensor detection temperature became lower than -1°C in heating operation.</p> <p>(2) Contents of control 1) Master outdoor unit Drive the inverter with the minimum frequency. When frequency of the inverter command is set to the minimum frequency, the defrost signal is sent to the indoor unit and the terminal outdoor unit. After then, turn off 4-way valve to stop the outdoor fan. The upper limit of the inverter frequency is 90Hz during defrost control.</p> <p>2) Terminal outdoor unit</p> <ul style="list-style-type: none"> • When the defrost conditions are satisfied, the defrost signal is sent to the master outdoor unit. • After receiving the defrost signal from the master outdoor unit, turn off 4-way valve. After then, stop the outdoor fan. • During defrost control, turn on all the fixed-speed compressors. <p>(3) Stop conditions of defrost operation 1) Common conditions When the specified time has passed after 4-way valve was turned off, the defrost operation completes based upon conditions of TE sensor temperature detection value or Pd pressure value. When 10 minutes have passed after start of the defrost operation, finish the defrost operation manually.</p> <p>2) Master outdoor unit The operation shifts to the defrost stop control when the common conditions of the defrost stop operation have been satisfied and the defrost signal has completed from all the terminal outdoor units.</p> <p>3) Terminal outdoor unit</p> <ul style="list-style-type: none"> • When the common conditions of the defrost stop operation have been satisfied, the defrost signal to the master outdoor unit completes. • The operation shifts to the defrost stop control when the defrost stop conditions have been satisfied and the defrost stop signal has been received from the master outdoor unit. <p>(4) Stop control of defrost operation 1) Master outdoor unit Set the outdoor fan to the maximum No. of waves 5 seconds after turning on 4-way valve. The heating fan control is performed after then.</p> <p>2) Master outdoor unit</p> <ul style="list-style-type: none"> • Drive the inverter with the minimum frequency. If the fixed-speed compressor is off, turn on it, and keep ON status if the fixed-speed compressor is on. When the terminal outdoor unit is connected, send the defrost stop signal. • After then, turn on 4-way valve to stop the defrost signal which is being sent to the indoor unit. <p>3) Terminal outdoor unit</p> <ul style="list-style-type: none"> • Keep ON status of the fixed-speed compressor 1 and 2. If they are off, turn on the compressor. • Turn on 4-way valve after the specified time has passed from when the defrost stop signal was received from the master outdoor unit. • After then, execute control for compressor capacity based upon compressor start/stop ON/OFF signal from the master outdoor unit. 	<ul style="list-style-type: none"> • When the conditions are satisfied, each outdoor unit starts defrost operation concurrently. • When the outdoor units are combined, the defrost operation continues forcibly for 2 minutes if the defrost operation has started once. • When the outdoor units are combined, the fan driving may be controlled by Pd pressure during defrost operation.

Item	Operation explanation and applied data, etc.	Remarks																																	
8. Release valve control	<p>(1) SV2 gas balance control</p> <p>This control is executed to balance the gas when opening SV2 while the compressor is off, in order to decrease the activation load in the next compressor-ON time. This control is individually executed by the master outdoor unit and each server outdoor unit.</p> <p>1) Control conditions When the compressor is switched from ON to OFF operation.</p> <p>2) Contents of control</p> <ul style="list-style-type: none"> The control point is exchanged by P (P_d pressure - P_s pressure) immediately before compressor stop. When $P \geq P_1$, SV2 is opened. After SV2 has been opened, SV2 is turned off when $P < P_2$. When $P < P_1$, SV2 is closed. <p style="text-align: right;">(MPa)</p> <table border="1" data-bbox="373 680 1114 909"> <thead> <tr> <th rowspan="3">Pd pressure control point P1, P2</th> <th colspan="2">Heating</th> <th colspan="4">Cooling</th> </tr> <tr> <th colspan="2">Master outdoor compressor OFF</th> <th colspan="2">Master outdoor compressor OFF</th> <th colspan="2">Master outdoor compressor ON</th> </tr> <tr> <th>P1</th> <th>P2</th> <th>P1</th> <th>P2</th> <th>P1</th> <th>P2</th> </tr> </thead> <tbody> <tr> <td>In case of master</td> <td>1.3</td> <td>1.1</td> <td>1.3</td> <td>1.1</td> <td>—</td> <td>—</td> </tr> <tr> <td>In case of terminal</td> <td>1.3</td> <td>1.1</td> <td>1.3</td> <td>1.1</td> <td>0.5</td> <td>0.4</td> </tr> </tbody> </table> <p>(2) SV2 high pressure release control</p> <p>This control is to control pressure rising in low-frequency operation of the inverter.</p> <p>1) Control conditions</p> <ul style="list-style-type: none"> Heating operation is performed. (Except while defrost control is performed.) When No.1 compressor of the master outdoor unit only is singly operated. (When 42Hz or lower command is output in case of inverter unit.) <p>2) Contents of control</p> <ul style="list-style-type: none"> SV2 is turned on when P_d pressure ≥ 2.7MPa. SV2 is turned off when P_d pressure ≤ 2.05MPa. <p>3) Stop conditions</p> <ul style="list-style-type: none"> In stop time, thermostat OFF, defrost operation, or cooling operation. When No.2 compressor of the master outdoor unit is ON. When even one of the terminal compressors is ON. When the inverter frequency command becomes 51Hz or higher. <p>(3) SV2 low pressure release control</p> <p>This control is to prevent quick pressure lowering in transient operation. This control is individually executed by the master outdoor unit and each server outdoor unit.</p> <p>This control is executed as necessary except during stop time and thermostat-OFF time.</p> <p>1) Contents of control</p> <ul style="list-style-type: none"> SV2 is opened when P_s pressure ≤ 0.08 MPa SV2 is closed when P_s pressure > 0.12 MPa <p>(4) SV2 compressor case bypass control</p> <p>This control is to prevent oil dilution up or 2-layers separation status in transient operation. This control is individually executed by the master outdoor unit and each server outdoor unit.</p> <p>This control is executed during compressor-ON (except during oil level detection controlling).</p>	Pd pressure control point P1, P2	Heating		Cooling				Master outdoor compressor OFF		Master outdoor compressor OFF		Master outdoor compressor ON		P1	P2	P1	P2	P1	P2	In case of master	1.3	1.1	1.3	1.1	—	—	In case of terminal	1.3	1.1	1.3	1.1	0.5	0.4	
Pd pressure control point P1, P2	Heating		Cooling																																
	Master outdoor compressor OFF		Master outdoor compressor OFF		Master outdoor compressor ON																														
	P1	P2	P1	P2	P1	P2																													
In case of master	1.3	1.1	1.3	1.1	—	—																													
In case of terminal	1.3	1.1	1.3	1.1	0.5	0.4																													

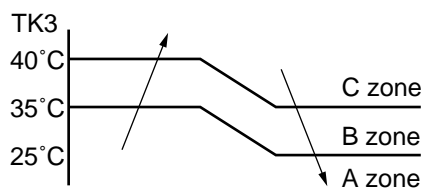
Item	Operation explanation and applied data, etc.	Remarks						
8. Release valve control (Continued)	<p>1) Contents of control SV2 is opened when the following conditions are satisfied.</p> <ul style="list-style-type: none"> Compressor status changes from OFF to ON. During defrost control (From when 4-way valve is turned off.) Oil recovery controlling is performed in cooling mode. SV2 is opened when TK3 sensor detects 2°C or lower temperature, and closed when TK3 sensor detects 5°C or higher temperature during compressor-ON time. No. of outdoor fan waves is 3 waves or less during cooling compressor-ON. <p>(5) SV41, 42 low pressure release control This control is to prevent low pressure lowering in defrost operation. This control is individually executed by the master outdoor unit and each terminal outdoor unit. This control is executed during defrost operation or activation time of the heating operation.</p> <p>1) Contents of control SV41 and 42 are opener (ON) when PS pressure ≤ 0.05 MPa, and they are closed (OFF) when PS pressure ≥ 0.1 MPa.</p>							
9. Fixed-speed compressor high pressure release control	<p>This control is to stop the fixed-speed compressor of each outdoor unit according to Pd pressure value. This control is individually executed by the master outdoor unit and each server outdoor unit.</p> <p>1) Contents of control</p> <ul style="list-style-type: none"> The fixed-speed compressor stops when Pd pressure is over P1. Sets the fixed-speed compressor reactivation-proof timer for 10 minutes, and this control finishes. 	<ul style="list-style-type: none"> No. 2 compressor stops with Pd ≥ P1 = 2.80 MPa, No. 1 compressor stops with Pd ≥ P1 = 2.90 MPa, 						
10. Compressor winding heating control	<p>This control is to prevent stagnation of refrigerant in the compressor case by turning on electricity to heat windings while the inverter compressor stops. This control is executed by the master outdoor unit (For inverter unit) only.</p> <p>If electricity is not turned on for a specified time before trial operation when installation work has finished, a fault of the compressor may be caused. When the power supply has been interrupted for a long time, and the operation starts from the status that the power supply has been left as it was, it is desirable to turn on the power before start of operation as per the trial operation time.</p> <p>(1) Control conditions Compressor stops and TD < 35°C.</p> <p>(2) Contents of control This control is executed by temperature detected by TK3 sensor as shown in the following figure.</p> <p>NOTE : Sound of turning-on power may be heard during heat winding operation, but it is not an error/fault.</p>  <table border="1" data-bbox="363 1870 1141 2049"> <thead> <tr> <th>A zone</th> <th>B zone</th> <th>C zone</th> </tr> </thead> <tbody> <tr> <td>Continuous switch-on power</td> <td>Intermittent switch-on power ON : 10 minutes OFF : 5 minutes</td> <td>No switch-on power</td> </tr> </tbody> </table>	A zone	B zone	C zone	Continuous switch-on power	Intermittent switch-on power ON : 10 minutes OFF : 5 minutes	No switch-on power	
A zone	B zone	C zone						
Continuous switch-on power	Intermittent switch-on power ON : 10 minutes OFF : 5 minutes	No switch-on power						

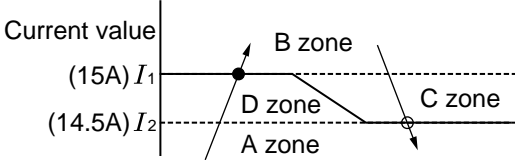
Item	Operation explanation and applied data, etc.	Remarks
11. Crank case heater control	<p>This control is executed by the fixed-speed unit only.</p> <p>(1) Control contents</p> <ul style="list-style-type: none"> • This control is switch off when TK3 sensor detected 40°C or higher temperature, and switch on when TK3 sensor detected 35°C or lower temperature. • After the compressor status changed from OFF to ON, ON status continues for 10 minutes. 	
12. IPDU (inverter) control	<p>IPDU controls the inverter compressor by command frequency, frequency up/down speed, and current release control value from the interface P.C. board.</p> <p>The main controls of IPDU control P.C. board are described below.</p> <p>(1) Current release control</p> <p>The output frequency is controlled by AC input current value which is detected by T02 on the control P.C. board to prevent the inverter input current rising higher than the specified value.</p> <div style="text-align: center;">  </div> <p>A zone : The normal operation is executed. D zone : The present operation frequency is kept. B zone : The operation frequency is decreased. C zone : Decrease of the operation frequency stopped, and the present operation frequency is kept.</p> <p>(2) Heat sink temp. detection control</p> <ol style="list-style-type: none"> 1) The heat sink temp. is detected by thermistor in the compressor driving module Q200, and the inverter compressor driver stops at 105°C. 2) When the inverter compressor driver stopped, 1 is counted to the error count, and the error is determined with the same error code 3 though reactivated after 2 minutes 30 seconds. <p>NOTE : When the error has been determined, the heat in outdoor unit or on outdoor fan error is considered.</p> <p>(3) Over-current protective control</p> <ol style="list-style-type: none"> 1) The compressor stops when T03 on IPDU control P.C. board detects over-current. 2) When the compressor stopped, 1 is counted to the error count, and the compressor reactivates after 2 minutes 30 seconds. After reactivated, the error count is cleared if the operation continues for 10 minutes or more. 3) The error is determined with error code 8. <p>(4) High pressure SW control</p> <ol style="list-style-type: none"> 1) The compressor driver stops when high pressure SW at inverter compressor operates. 2) When the compressor driver stops, 1 is counted to the error count, and the compressor driver reactivates after 2 minutes 30 seconds. After reactivated, the error count is cleared if the operation continues for 10 minutes or more. 3) The error is determined with error code 3. 	

3-5-1-4. Other cautions

(1) Cooling operation in low ambient temperature

- 1) When low pressure is lowered, the freeze prevention control by the indoor unit TC sensor may decrease the frequency.
- 2) When low pressure is lowered, the cooling capacity control may decrease the frequency.
- 3) When discharge temp. sensor value lowers below 60°C, the frequency may be increased over the receive command from the indoor unit.
- 4) No. of electro-waves of the outdoor fan decreases, and a low continuous sound may be heard when power is turned on. (This sound is not abnormal.)

(2) PMV (Pulse Motor Valve)

- 1) When the power is turned on, a tap sound to initialize PMV is heard. If this sound is not heard, PMV operation error is considered. However, this sound may not be heard at a place where outside sound takes precedence.
- 2) Do not remove the driving part (Head part) of PMV during operation. It may cause error in opening.
- 3) When transporting (replacing) the set, never keep the driving part removed. The valve is closed, and the valve is damaged by sealed liquid status.
- 4) When removing the driving part and attaching it again, push in it securely until a “click” sound can be heard. Then, turn off the power once, and turn on the power again.

3-5-2. Indoor Unit

Item	Operation explanation and applied data, etc.	Remarks															
1. Power supply is reset.	(1) Automatic remote controller function set up Based upon the result of selecting indoor unit model, set up and display range of the remote controller is selected.	Operation mode range Air volume select/Louver presence															
2. Operation select	(1) Based upon the operation select command from the remote controller or central controller, the operation mode is selected. <table border="1" style="margin: 10px auto;"> <thead> <tr> <th>Remote controller command</th> <th>Control outline</th> </tr> </thead> <tbody> <tr> <td>STOP</td> <td>Stops air conditioner.</td> </tr> <tr> <td>FAN</td> <td>Fan operation</td> </tr> <tr> <td>COOL</td> <td>Cooling operation</td> </tr> <tr> <td>HEAT</td> <td>Heating operation</td> </tr> </tbody> </table>	Remote controller command	Control outline	STOP	Stops air conditioner.	FAN	Fan operation	COOL	Cooling operation	HEAT	Heating operation						
Remote controller command	Control outline																
STOP	Stops air conditioner.																
FAN	Fan operation																
COOL	Cooling operation																
HEAT	Heating operation																
3. Room temp. control	(1) Adjustment range <table border="1" style="margin: 10px auto;"> <thead> <tr> <th></th> <th>In cooling</th> <th>In heating</th> </tr> </thead> <tbody> <tr> <td>Remote controller set up temp.</td> <td>18 to 29°C</td> <td>18 to 29°C</td> </tr> <tr> <td>Operation temp.</td> <td>18 to 29°C</td> <td>18 to 29°C</td> </tr> </tbody> </table> (2) Operation point with compressor-OFF (3) Operation temp. precision $\pm 1^\circ\text{C}$ (4) Differential 1 deg		In cooling	In heating	Remote controller set up temp.	18 to 29°C	18 to 29°C	Operation temp.	18 to 29°C	18 to 29°C							
	In cooling	In heating															
Remote controller set up temp.	18 to 29°C	18 to 29°C															
Operation temp.	18 to 29°C	18 to 29°C															
Temp. correction	(5) Using DIP switch (SW03) of the indoor microprocessor, the control temp. of the room temp. can be corrected in heating operation. <table border="1" style="margin: 10px auto;"> <tbody> <tr> <td>SW03 1</td> <td>ON</td> <td>ON</td> <td>OFF</td> <td>OFF</td> </tr> <tr> <td>SW03 2</td> <td>ON</td> <td>OFF</td> <td>ON</td> <td>OFF</td> </tr> <tr> <td>Heating control temp.</td> <td>+0°C</td> <td>+2°C</td> <td>+4°C</td> <td>+6°C</td> </tr> </tbody> </table>	SW03 1	ON	ON	OFF	OFF	SW03 2	ON	OFF	ON	OFF	Heating control temp.	+0°C	+2°C	+4°C	+6°C	Set temperature Ts (Max.) = 35°C
SW03 1	ON	ON	OFF	OFF													
SW03 2	ON	OFF	ON	OFF													
Heating control temp.	+0°C	+2°C	+4°C	+6°C													

Item	Operation explanation and applied data, etc.	Remarks
4. Automatic capacity control	<p>(1) Based upon difference between T_a and T_s, the operation frequency is indicated to the outdoor unit.</p> <div style="display: flex; justify-content: space-around;"> <div style="text-align: center;"> <p>COOL</p> </div> <div style="text-align: center;"> <p>HEAT</p> </div> </div> <p>NOTE : The operation frequency in the above zone differs according to horse power or protective control of the outdoor unit.</p>	<p>T_s : Set up temp. T_a : Room temp.</p>
5. Capacity correction control	<p>(1) Frequency correction control Frequency of the outdoor unit is corrected so that the present capacity reaches to the certain specified capacity.</p> <p>(2) PMV opening correction control PMV opening is corrected so that the refrigerant status of the indoor unit becomes most appropriate status.</p>	
6. Air volume control	<p>(1) By the command from the remote controller or the central controller, "HIGH", "MED.", "LOW", or "AUTO" operation is executed.</p> <p>(2) The status becomes "Ultra LOW" and "STOP" when thermostat is turned off during heating operation.</p> <p>(3) While air volume is in AUTO mode, the air volume is changed according to the difference between T_a and T_s.</p> <div style="display: flex; justify-content: space-around;"> <div style="text-align: center;"> <p>COOL</p> </div> <div style="text-align: center;"> <p>HEAT</p> </div> </div>	<p>Duct : Air volume "FIX".</p> <p>"STOP" controls prevention of cold air discharge by TC2.</p>
7. Prevention of cold air discharge	<p>(1) In heating operation, the indoor fan is controlled based upon the detection temperature of TC2 (Temperature sensor of indoor heat exchanger).</p> <div style="display: flex; align-items: center;"> <div style="flex: 1;"> </div> <div style="flex: 1;"> <p>A zone : Set air volume from remote controller B zone : Low air C zone : OFF</p> </div> </div>	<p>"PRE-HEAT/DEFROST" go on.</p>

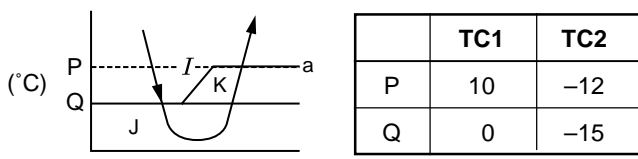
Item	Operation explanation and applied data, etc.	Remarks									
8. Freeze prevention control (Low temp. release)	<p>(1) In cooling operation, the air conditioner operates as described below based upon temp. detected by TC1 and TC2 sensors.</p> <ul style="list-style-type: none"> When "J" zone is detected for 5 minutes, the command frequency becomes "S0" to the outdoor unit. In "K" zone, the timer count is interrupted, and held. When "I" zone is detected, the timer is cleared and the operation returns to the normal operation. When the command frequency became S0 with continuation of "J" zone, operation of the the indoor fan in LOW mode until it reaches the "I" zone. <p>It is reset when the following conditions are satisfied.</p> <ol style="list-style-type: none"> TC1 $\geq 12^{\circ}\text{C}$ and $\geq \text{TC2 } 12^{\circ}\text{C}$ 30 minutes after the air conditioner has stopped. <div style="display: flex; align-items: center; margin-top: 10px;">  <table border="1" style="margin-left: 20px;"> <thead> <tr> <th></th> <th>TC1</th> <th>TC2</th> </tr> </thead> <tbody> <tr> <td>P</td> <td>10</td> <td>-12</td> </tr> <tr> <td>Q</td> <td>0</td> <td>-15</td> </tr> </tbody> </table> </div>		TC1	TC2	P	10	-12	Q	0	-15	
	TC1	TC2									
P	10	-12									
Q	0	-15									
9. Cooling refrigerant/Oil recovery control	<p>When the indoor units stand by, thermostat is OFF, or the indoor unit operates with "FAN" mode, PMV of the indoor unit is opened by a certain degree when the cooling refrigerant/Oil recovery signal is received from the outdoor unit.</p>	<ul style="list-style-type: none"> Only for 4-way ceiling cassette type, operate the indoor fan for approx. 3 to 4 min of the recovery operation. 									
10. Heating refrigerant/Oil recovery control	<p>The indoor unit which stops operation, thermostat is OFF, or operates with "FAN" mode performs the following controls when the heating refrigerant/Oil recovery signal is received from the outdoor unit.</p> <ol style="list-style-type: none"> PMV of the indoor unit is opened by a certain degree. Fan is stopped. Temperature of TC2 is detected, and PMV is closed. 	<ul style="list-style-type: none"> On the indoor unit in which thermostat is OFF or which operates with "FAN" mode, "PRE-HEAT/DEFROST" go on. For 4-way ceiling cassette type only, operate the indoor fan for approx. 1 minute after recovery operation. 									
11. Short intermittent operation compensation control	<ol style="list-style-type: none"> For 5 minutes after the operation has started, the operation is continued even if entering thermostat-OFF condition. However, if the thermostat has been turned off by changing the set up temp., the thermostat is OFF with even the above condition. The protective control has priority. 										
12. Drain pump control	<ol style="list-style-type: none"> During "COOL" operation, the drain pump operates. When the float SW operates, the compressor stops and the drain pump operates. When the operation of the float SW continues for 2 minutes, a check code is generated. 	<p>CHECK code "0b"</p> <p>When "0b" occurred, the outdoor units stop and "STANDBY" is displayed on the remote controllers of all the indoor units.</p>									
13. Elimination of remaining heat	<ol style="list-style-type: none"> When the air conditioner stops in the "HEAT" mode, drive the indoor fan with "LOW" mode for approx. 30 seconds. 										
14. Auto louver control	<ol style="list-style-type: none"> When the louver signal has been received from the remote controller or the central controller, the auto turn louver operates if the indoor fan is operating. 										

Item	Operation explanation and applied data, etc.	Remarks
15. Frequency fix operation (Trial operation)	<p>(1) When holding the START/STOP SW on the remote controller continuously for 5 seconds, the mode changes to Trial operation mode. Then, set the indoor fan to "HIGH" mode to operate the frequency fix.</p> <p>(2) During operation, other operation.</p>	<p>Command frequency COOL [SD] "COOL L" HEAT [SF] "HEAT H"</p>
16. Filter sign display	<p>(1) The operation time of the indoor fan is measured and stored in memory, and it is displayed on the remote controller LCD after the specified time (120H/2500H). Selection of 120H/2500H is set at the factory.</p> <p>(2) When FILTER RESET switch on the remote controller is pushed, FILTER display disappears.</p>	<p>"FILTER" goes on.</p>
17. STANDBY display	<p>(1) When phase order of the power supply wiring is incorrect.</p> <ul style="list-style-type: none"> • Over capacity combination of indoor units. • "COOL" operation cannot be performed because other indoor unit is under "HEAT" operation. • Selection of the operation mode is fixed to "COOL" or "HEAT", and an operation reversed to the specification is tried. • There is an indoor unit which stopped with the indoor overflow alarm "0b". <p>(2) The above indoor unit status that cannot operate enters standby status when the thermostat is turned off, and this status continues until STANDBY status is released.</p>	<p>"STANDBY" goes on.</p>
18. Center selection	<p>(1) The contents which can be operated on the remote controller at indoor unit side can be selected by set up at the central controller side.</p> <p>[Last-push priority] : Can be operated from both the remote controller at the indoor unit and at the central controller, and operates with the content as per last selection.</p> <p>[Center] : START/STOP and the timer operation can be handled on the remote controller at the indoor unit.</p> <p>[Operation forbidden] : Cannot be operated on the remote controller at the indoor unit. (as STOP status)</p>	<p>(No display)</p> <p>"CENTRAL" goes on.</p> <p>"CENTRAL" flashes.</p>

3-6. TROUBLESHOOTING

3-6-1. Check Method

On the remote controller and interface unit of the outdoor unit, the CHECK display LCD (Remote controller) or 7 segment LED (on microprocessor control P.C. board) an operation display is provided. Observing this display, you can understand the operation status. The method to judge an error/fault by using this self-diagnostic function is described below.

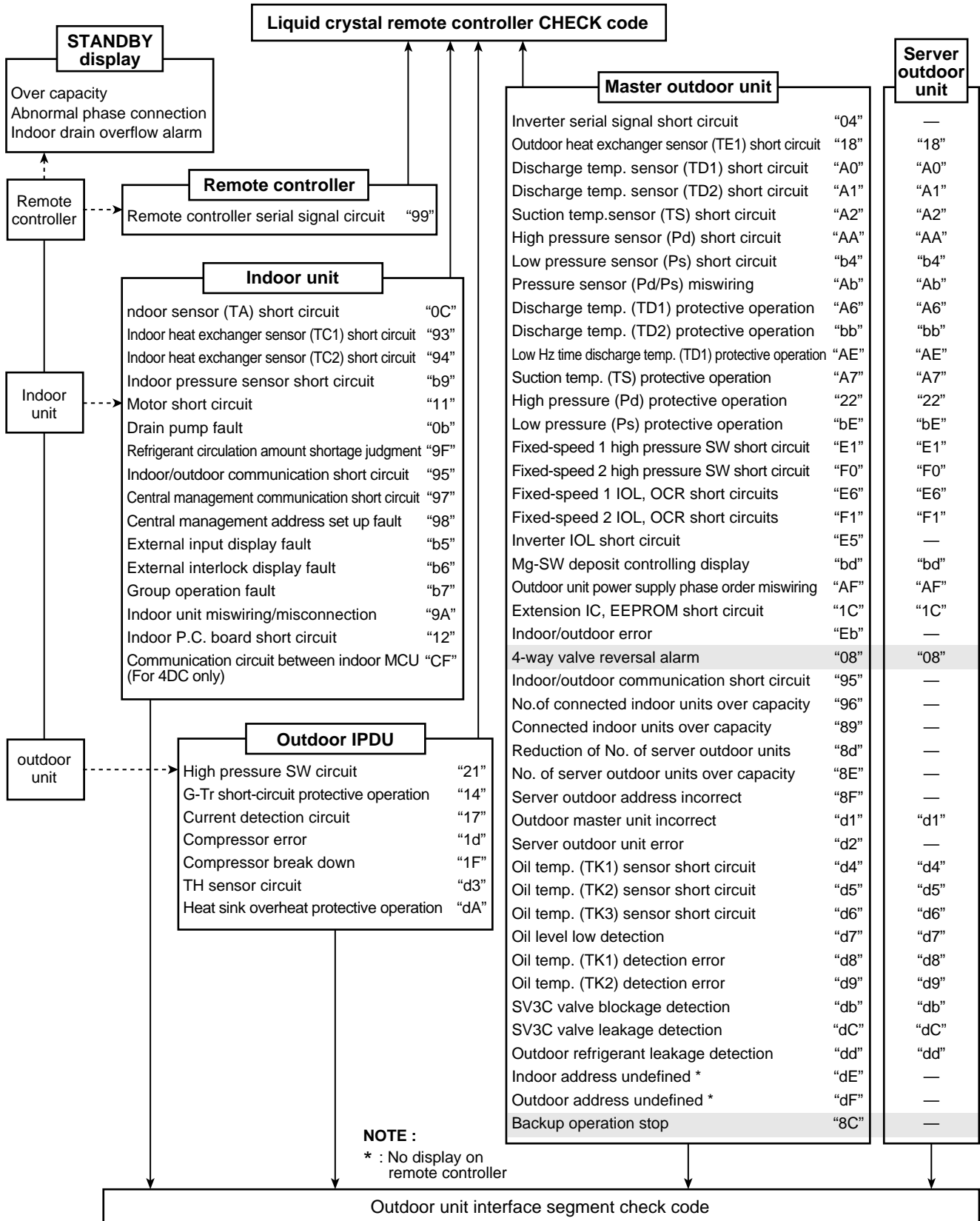

3-6-2. Troubleshooting with CHECK Display of Remote Controller

3-6-2-1. In case of main remote controller/sub-remote controller RBC-AM1E RBC-AS1E

1. Operation for CHECK display

When pushing the CHECK switch, the indoor unit No. (Group address No.) which sends the check code is displayed at the right side of the set up TEMP. display section, and the check data of 2 errors/faults x 16 units is displayed in the set up temp. display section.

If there is a filter display, the indoor unit No. which sends the filter signal is displayed at the right side of the set up temp. display section, and then the check code is displayed as described above.

(1 display for 3 seconds)

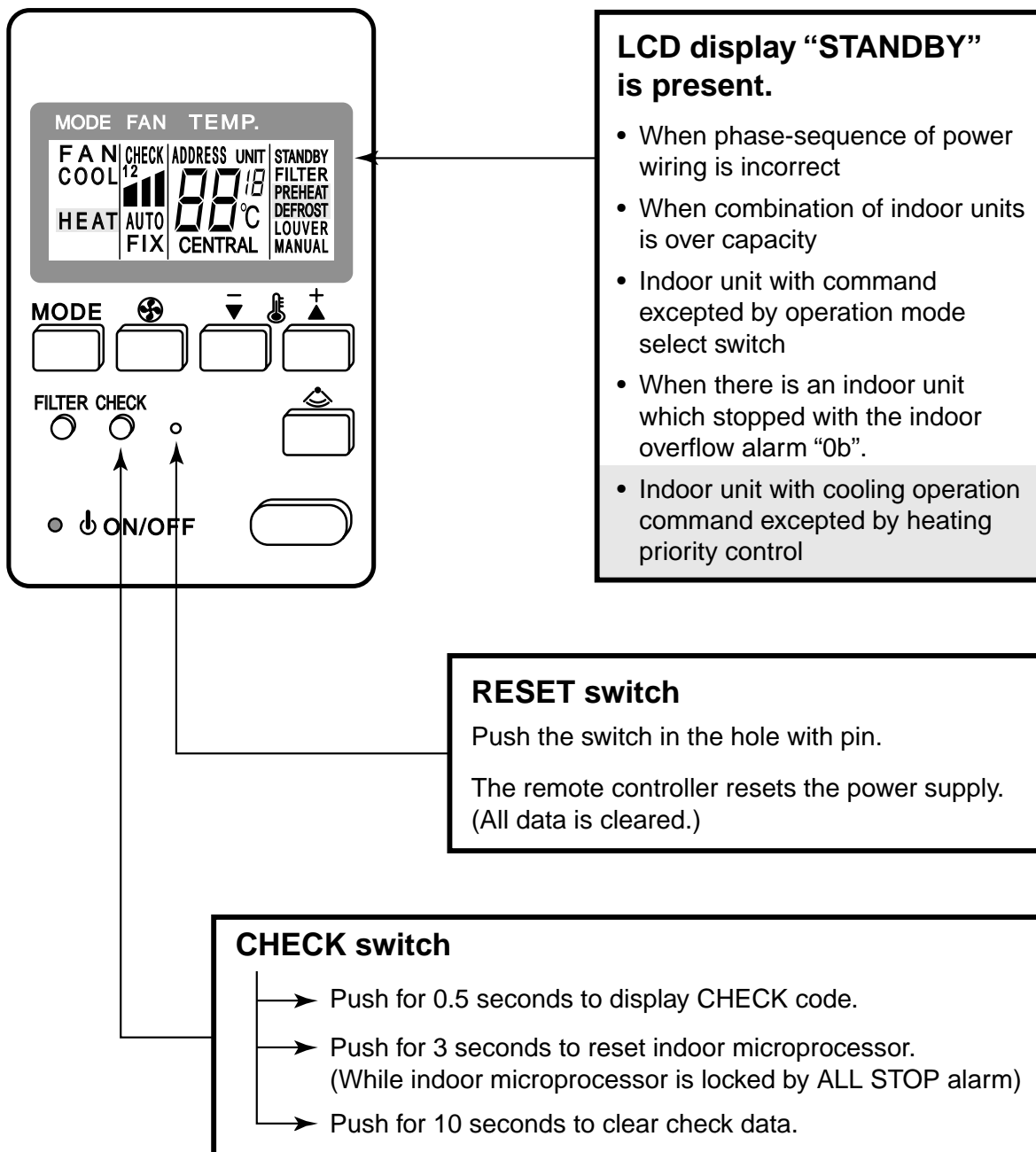

2. Reading of CHECK monitor display

<7 segment display>

0	1	2	3	4	5	6	7	8	9	10	11	12	13	14	15	Hexadecimal notation
0	1	2	3	4	5	6	7	8	9	10	11	12	13	14	15	Decimal notation

<Display on CHECK monitor>

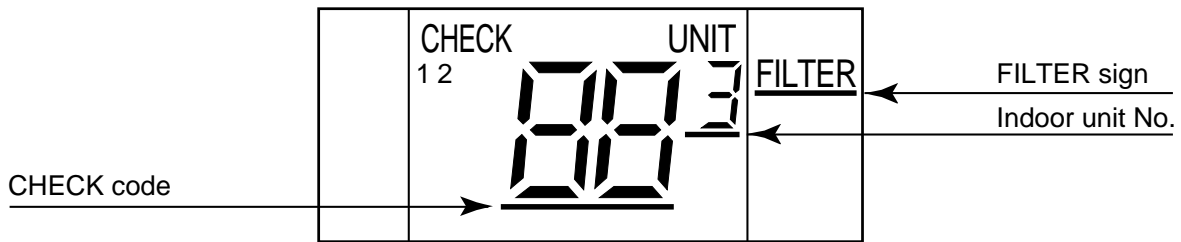

<FILTER data>

(Example) Case that Filter signal is sent from No.1 and No.16 units under group operation



<CHECK data>

(Example) Room temp.sensor of No.1 is defective.
 In No.16, first the heat exchanger sensor has failed.
 Next, interconnection wire (serial signal line) of indoor/outdoor is defective.

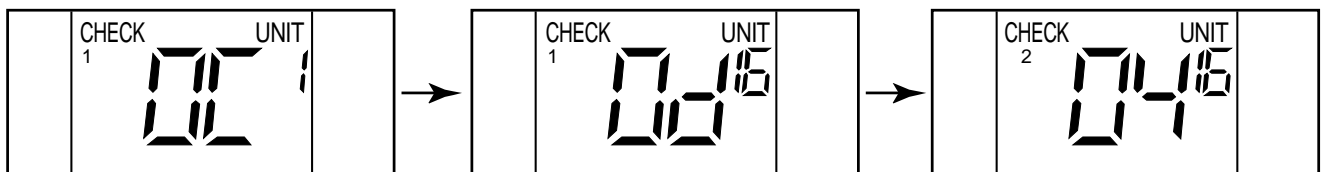

(Example) There is no check data.

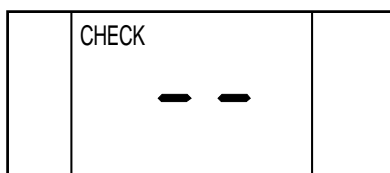

3-6-2-2. Remote controller with timer RBC-AT1E

1. Operation for CHECK display

When pushing the CHECK switch, the indoor unit No. (Group address No.) which sends the check code is displayed in the set up temp. display section, and check code is displayed in the TIME display section. If FILTER display (air filter cleaning sign) is present, the indoor unit No. which sends the filter signal is displayed in the set up temp. display section, and then the check code is displayed. (1 display for 3 seconds)

LCD display STANDBY is present.

- When phase-sequence of power wiring is incorrect
- When combination of indoor units is over capacity.
- Indoor unit with command excepted by operation mode select switch
- When there is an indoor unit which stopped with the indoor overflow alarm "0b".
- Indoor unit with cooling operation command excepted by heating priority control

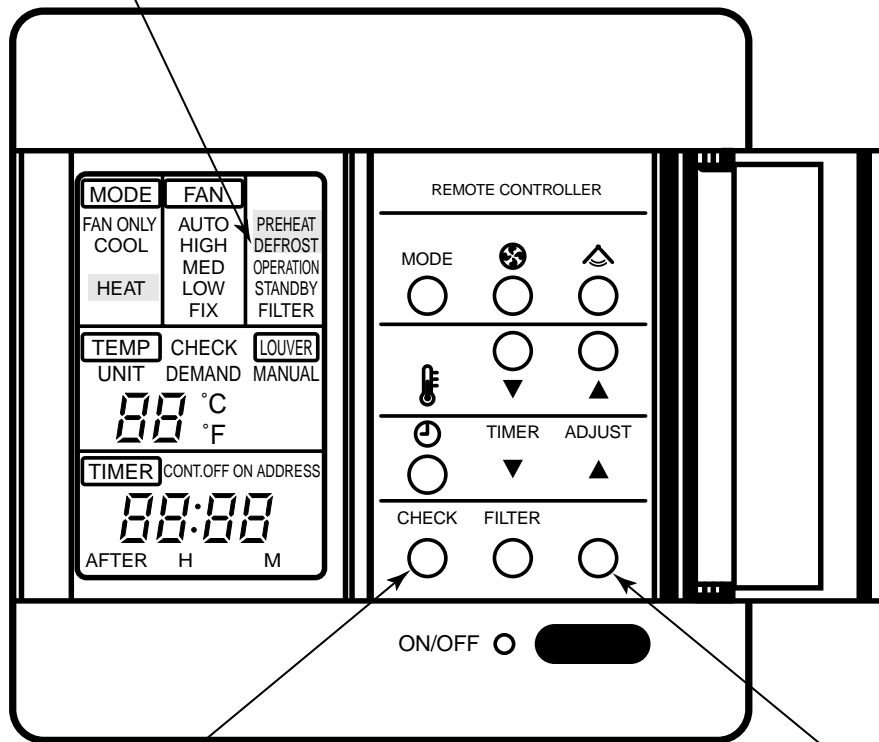

(This display is for remote control with timer.)

CHECK switch

- ➔ Push for 0.5 seconds to display CHECK code.
- ➔ Push for 3 seconds to reset indoor microprocessor. (While indoor microprocessor is locked by ALL STOP alarm)
- ➔ Push for 10 seconds to clear check data.

RESET switch

- ➔ Push the switch in the hole with pin. The remote controller resets initialized. (All data is cleared.)

2. Reading of CHECK monitor display

<7 segment display>

0	1	2	3	4	5	6	7	8	9	10	11	12	13	14	15
Hexadecimal notation															
Decimal notation															

<FILTER data>

(Example) Filter signal is sent from No.1 and No.15 units under grouping operation

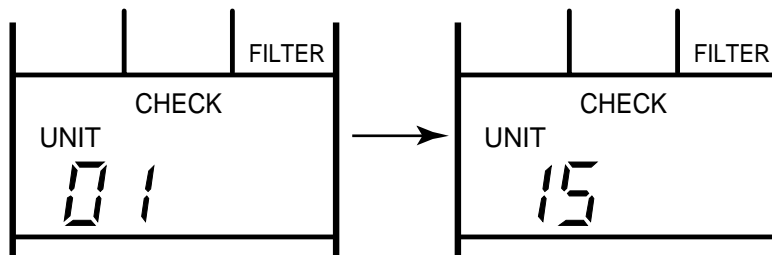

<CHECK data>

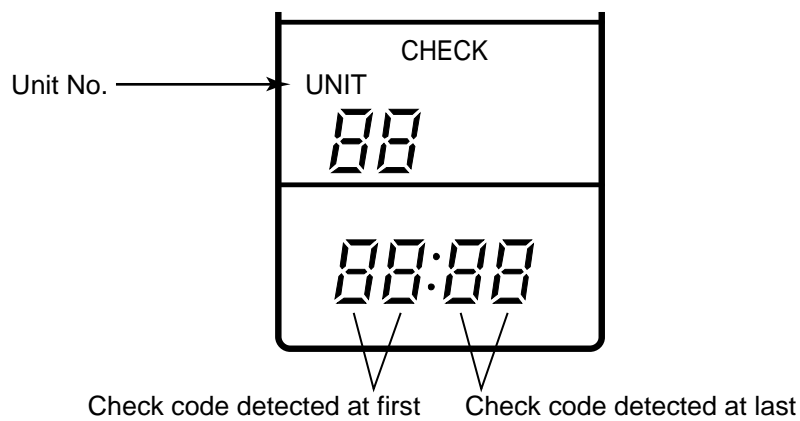

(Example) Room temp.sensor of No.1 is defective.
In No.15, first the indoor heat exchanger sensor has failed.
Next, interconnection wire (bus communication line) of indoor/outdoor is defective.

(Example) There is no check data.

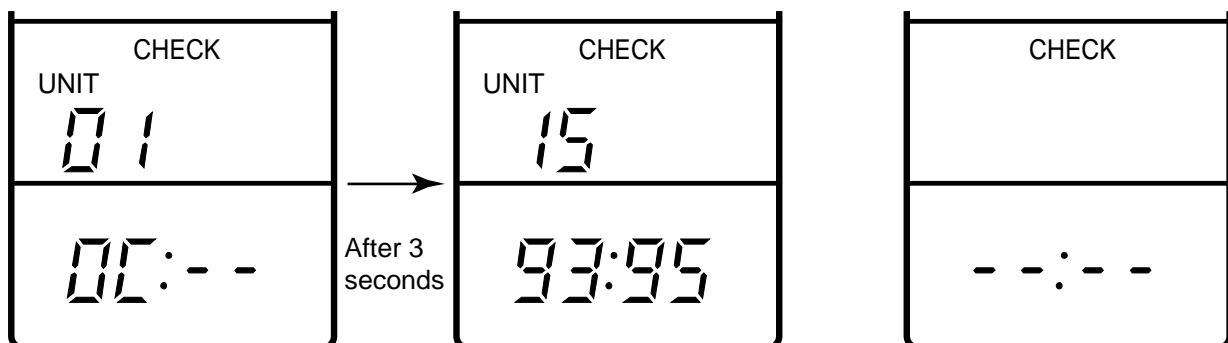

3-6-2-3. Central remote controller

1. Operation for CHECK display

When pushing the CHECK switch, the indoor unit No. (Network address No.) including the check data is displayed in the UNIT No. display section, and the check code is displayed in the set up temp. display section.

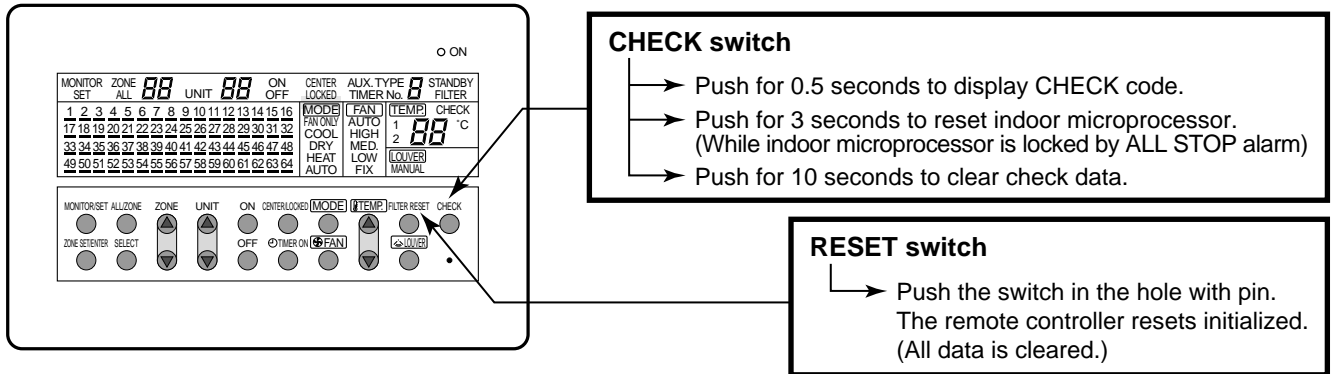

2. Reading of CHECK monitor display

<7 segment display>

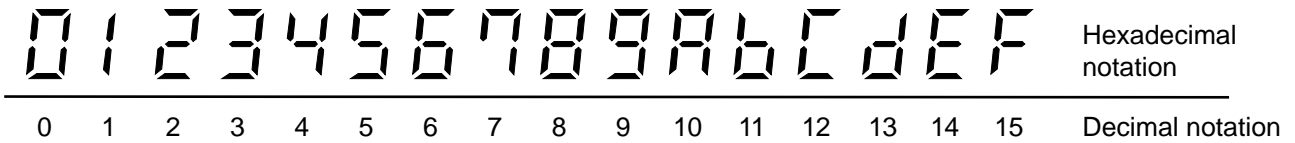

<Display on CHECK monitor>

Unit line No. (Network address No.)

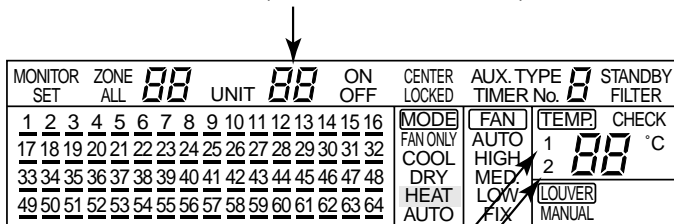

Check code detected at first

Check code detected at last

(Example)

There is no check data.

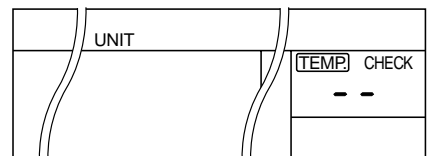

<CHECK data>

(Example)

In No.1 unit, first the interconnection wire (bus communication line) of indoor/outdoor has failed.
Next, the room temp. sensor is defective.
For No.16 unit, the high pressure switch at the inverter unit side operates.

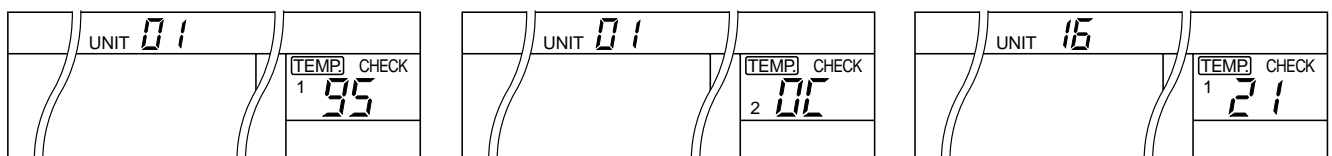

3-6-3. Check Codes Displayed on the Remote Controller and Outdoor Unit and Check Positions

Check code	Detected position	Check code name	Cause (Position)	Trouble detection condition	Check item (Position)
04	Interface	Inverter communication alarm	Inverter serial signal	Serial signal from inverter interruption.	<ul style="list-style-type: none"> Outdoor P.C. board (Interface, IPDU) error Check communication connector (CN600) between outdoor interface and IPDU P.C. boards.
08	Interface	4-way valve reversal alarm	4-way valve circuit	Abnormal refrigerating cycle data was detected in heating operation.	<p><Check for all the outdoor units in the identical line is necessary.></p> <ul style="list-style-type: none"> 4-way valve is defective. Check defective 4-way valve coil and connection of connectors. Check characteristics of TS sensor/TE sensor resistance value. Check characteristics of Pd pressure sensor/Ps pressure sensor output voltage. Check power supply wiring of fixed-speed compressor and Mg-SW error.
0b	Indoor	Indoor drain overflow alarm	Float switch	<ul style="list-style-type: none"> Float switch operates continuously for 2 minutes. Float switch circuit disconnected or connector out of place. 	<ul style="list-style-type: none"> Check connection of float switch connector (CN11) (Indoor main P.C. board (MCC-1361)). Check drain pump operation. Check drain pump circuit. Check for blockage of water drain pipe. Check failure of indoor main P.C. board (MMC-1361).
0C	Indoor	Indoor TA sensor alarm	Indoor temp. sensor (TA)	Sensor resistance value was infinity or zero (Open, Short circuit).	<ul style="list-style-type: none"> Check connection and wiring of TA connector (CN04). (Indoor main P.C. board (MCC-1361)). Check characteristics of TA sensor resistance value. Check failure of indoor main P.C. board (MMC-1361).
11	Indoor	Indoor fan motor alarm	Indoor fan motor circuit	Status that detection value of motor speed is incorrect continuously	<ul style="list-style-type: none"> Check connection and wiring of fan connector (CN07, CN18). Check running capacitor error for indoor fan. Check fan motor error. Check indoor P.C. board error. Check effect of outside air process (OA).
11 (4DC)					<ul style="list-style-type: none"> Check connection and wiring of fan connector (CN33, CN34) (Indoor motor P.C. board (MCC-1382)). Check connection of lead wire between connector (CN28) of indoor main P.C. board (MCC-1361) and connector (CN27) of indoor motor P.C. board (MCC-1382). Check indoor fan motor error. Check failure of indoor main P.C. board (MCC-1361). Check failure of indoor main P.C. board (MCC-1382). Check effect of outside air process (OA).
12	Indoor	Other indoor error	Indoor P.C. board (EEPROM/ Peripheral circuit)	Indoor P.C. board (MCC-1361) is not operating correctly.	<ul style="list-style-type: none"> Check power supply voltage. Check noise of peripheral equipment. Check failure of indoor main P.C. board (MCC-1361).
14	Inverter	G-Tr short-circuit protective system error	Inverter over-current protective circuit	Instantaneous over-current was detected when inverter compressor was activated.	<ul style="list-style-type: none"> Check power supply wiring. Check connection on IPDU P.C. board. Check reactor connection. Check AC fuse disconnection. Check cause of abnormal overload operation. Check inverter compressor error and short circuit. IGBT conductive check Check shortage of capacitor capacity. Check outdoor P.C. board (IPDU) error.

Check code	Detected position	Check code name	Cause (Position)	Trouble detection condition	Check item (Position)
17	Inverter	Current detection circuit system alarm	Inverter current detection circuit	Status that current flows over the set value thus inverter compressor stopped is detected.	<ul style="list-style-type: none"> • Check wiring of current detection circuit system. • Check outdoor P.C. board (IPDU) error.
18	Interface	TE1 sensor alarm	Outdoor heat exchanger sensor (TE1)	Sensor resistance value was infinity or zero (Open, Short) (automatic backup operation after judgment)	<ul style="list-style-type: none"> • Check connection of TE1 sensor connector. • Check characteristics of TE1 sensor resistance value. • Check outdoor P.C. board (Interface) error.
1C	Interface	Extension IC, EEPROM alarm	Outdoor interface P.C. board circuit	Outdoor P.C. board (Interface) is not operating correctly	<ul style="list-style-type: none"> • Check power supply voltage. • Check power supply noise. • Check outdoor P.C. board (Interface) error.
1d	Outdoor	Compressor alarm	Inverter compressor system circuit	Over-current was detected several seconds after inverter compressor was activated.	<ul style="list-style-type: none"> • Check inverter compressor lock. • Check power supply voltage (AC342–457V). • Check wiring of inverter compressor system and miss-phase. • Check connection of connector on IPDU P.C. board. • Conductive check for crank case heater. (Activation error check by liquid stagnation in compressor) • Check outdoor P.C. board (IPDU) error.
1F	Outdoor	Compressor break down	Inverter current detection circuit	After inverter frequency reduced by current release, over-current was detected and stopped.	<ul style="list-style-type: none"> • Check power supply voltage (AC342–457V for 50Hz, AC342–418V for 60Hz). • Check cause of abnormal overload operation. • Check current sensor detection circuit system. • Check outdoor P.C. board (IPDU) error. • Check outdoor fan system error. • Check for blockage inside of cooling duct of heat sink.
21	Outdoor	Inverter high-pressure SW system alarm	Inverter high-pressure SW system circuit	<p>High-pressure SW or IOL operated.</p> <ul style="list-style-type: none"> ■ High-pressure Pd \geq 2.5MPa : [21] is displayed. ■ High-pressure Pd $<$ 2.5MPa : [E5] is displayed. 	<ul style="list-style-type: none"> • Check inverter high-pressure SW error. • Check IOL operation and case temp. (Check cause of overload operation.) • Check service valve is fully open. • Check connection of outdoor fan connector. • Check outdoor fan motor, running capacitor error. • Check for blockage in outdoor PMV. <ul style="list-style-type: none"> 1) Refrigerant choke circuit (PMV A) 2) Cooling bypass circuit (PMV B) 3) Liquid line check valve (Cooling only model) • Check for blockage in outdoor/indoor heat exchanger. • Short-circuit status between outdoor discharge air and suction air • Check Pd pressure sensor error. • Check for blockage in hot gas bypass SV2 circuit. • Check outdoor P.C. board (Interface) error. • Check open valve status of indoor PMV. • Check miswiring of communication line between indoor and outdoor.

Check code	Detected position	Check code name	Cause (Position)	Trouble detection condition	Check item (Position)
22	Interface	High-pressure protective operation	High pressure up protection by high-pressure Pd sensor detection value	Pd sensor detected 3.0MPa or more	<ul style="list-style-type: none"> • Check Pd pressure sensor error. • Check service valve full open. • Check cause of overload operation. • Check connection of outdoor fan connector. • Check outdoor fan motor, running capacitor error. • Check for blockage in outdoor PMV. <ol style="list-style-type: none"> 1) Refrigerant choke circuit (PMV A) 2) Liquid line check valve (Cooling only model) • Check for blockage in outdoor/indoor heat exchanger. • Short-circuit status between outdoor discharge air and suction air • Check for blockage in hot gas bypass SV2 circuit. • Check outdoor P.C. board (Interface) error. • Check open valve status of indoor PMV. • Check miswiring of communication line between indoor and outdoor.
89	Interface	Indoor capacity over	Total connected capacity over of indoor units	<p>Total capacity of indoor units 135% (more than) total capacity of outdoor units.</p> <p>[NOTE] When this code is displayed after set up of change when fault occurred on outdoor unit, set up "Over capacity was not detected." Turn on SW9 Bit2 on interface P.C. board of inverter outdoor unit.</p>	<ul style="list-style-type: none"> • Check indoor unit connection capacity. • Check indoor unit HP capacity. • Check outdoor HP set up. • Check outdoor P.C. board (IPDU) error.
8C	Interface	Outdoor backup operation prohibited	Prohibited status of outdoor backup operation	Operation mode of the system changed to HEAT while backup operation of the outdoor unit was being set up in cooling only model.	<ul style="list-style-type: none"> • If there is a unit which outdoor backup operation is being set up in cooling only model, heating operation is not performed.
8d	Interface	Reduction of No. of connected outdoors	No. of connected outdoor unit communication	<p>No. of connected outdoor units was judged to be less than No. of units stored in memory of EEPROM</p> <p>[NOTE] If this code is displayed when backup operation of outdoor error was performed, set "Alarm clear".</p>	<ul style="list-style-type: none"> • Check connection of communication. • Check communication line between outdoor units. • Check power supply OFF (power supply breaker) of outdoor unit. • Check outdoor P.C. board (Interface) error. • Presence check of outdoor backup set up
8E	Interface	Excessive No. of connected outdoors	No. of connected outdoor unit communication	No. of outdoor units exceeded 5.	<ul style="list-style-type: none"> • Check connected No. of outdoor units. (Max. 5 units per 1 system) • Check communication line between outdoor units. • Check outdoor P.C. board (Interface) error.
8F	Interface	Fixed-speed outdoor address duplication	Duplication of manual address switch set up of fixed-speed outdoor	Address No. of fixed-speed outdoor unit was duplicated under condition that address set up of outdoor unit was manual.	<ul style="list-style-type: none"> • Check address switch set up of fixed-speed outdoor. • Check outdoor P.C. board (Interface) error.
93	Indoor	Indoor TC1 sensor alarm	Indoor gas pipe temp. sensor (TC1)	<ul style="list-style-type: none"> • Sensor resistance value was infinity or zero (Open, Short). 	<ul style="list-style-type: none"> • Check connection of TC1 sensor connector (CN20) (Indoor main P.C. board (MCC-1361)). • Check characteristics of TC1 sensor resistance value. • Check failure of indoor main P.C. board (MCC-1361).

Check code	Detected position	Check code name	Cause (Position)	Trouble detection condition	Check item (Position)
94	Indoor	Indoor TC2 sensor alarm	Indoor liquid pipe temp. sensor (TC2)	<ul style="list-style-type: none"> • Sensor resistance value was infinity or zero (Open, Short). 	<ul style="list-style-type: none"> • Check connection of TC2 sensor connector (CN05) (Indoor main P.C. board (MCC-1361)). • Check characteristics of TC2 sensor resistance value. • Check failure of indoor main P.C. board (MCC-1361).
95	Interface	Communication alarm between indoor and outdoor	Inter-unit wire between indoor and outdoor (PQ control line)	<ul style="list-style-type: none"> • Communication was interrupted for a certain time. • There is no inverter outdoor unit. 	<ul style="list-style-type: none"> • Check power supply of indoor unit. (Turning on the power.) • Check power supply of outdoor unit. (Turning on the power.) • Check connection and disconnection of communication line (PQ) between indoor and outdoor. • Check connection of communication connector (CN101) of indoor main P.C. board (MCC-1361). • Check failure of indoor main P.C. board (MCC-1361). • Check failure of outdoor main P.C. board (Interface). • Check inverter outdoor set up (Presence of set up/duplication) when check code [U][–][9][5] is displayed at outdoor.
96	Interface	Disagreement detection between indoor and outdoor address	Inter-unit wire between indoor and outdoor (PQ control line)	<ul style="list-style-type: none"> • No. of connected indoor units exceeded 40. • Connected to other outdoor system or central management remote controller. 	<ul style="list-style-type: none"> • Check No. of indoor units connected to outdoor. • Check connection and miswiring of communication line (PQ) between indoor and outdoor. • Check connection of central management remote controller wiring. (Check connection and miswiring of communication line (XY).) • Check outdoor P.C. board (Interface) error.
97	Indoor	BUS communication alarm (1)	Central management system communication circuit	Communication of central management system interruption	<ul style="list-style-type: none"> • Check communication line (XY) at outdoor side. • Check indoor power supply wiring and voltage. • Check central management controller and indoor power supply system. (Check whether one side is not turned on.) • Check peripheral noise. • Check failure of indoor main P.C. board. (MCC-1361) • Check power failure. (Trouble may remain at central management side by power failure. The status returns to normal status by resetting power supply.)
98	Indoor	BUS communication alarm (2)	Central management address set up	Addresses duplicated.	<ul style="list-style-type: none"> • Check communication line (XY) at outdoor side. • When group operation is performed, check communication line of server unit. <p>[NOTE] When connecting XY communication line to server unit (No.2 to No.16), check code [98] is displayed.</p> <ul style="list-style-type: none"> • Network address duplication check • Check failure of Indoor main P.C. board (MCC-1361). • Check No. of connected central management controllers. (If multiple units are connected, correct to 1 unit.) • Check central management controller.

Check code	Detected position	Check code name	Cause (Position)	Trouble detection condition	Check item (Position)												
99	Remote controller	Indoor remote controller communication alarm	Indoor remote controller communication circuit	Serial between indoor main P.C. board (MCC-1361) and remote controller interruption.	<ul style="list-style-type: none"> • Check inter-unit wire (ABC). • Check disconnection and connector contact error. • Check remote controller error. • Check failure of indoor main P.C. board (MCC-1361). • Check duplication of indoor unit No.1. (When group operation is set up.) 												
9A	Indoor	Indoor miswiring/misconnection	Miswiring or misconnection of indoor unit	<p>By change of detection value of indoor unit temp. sensor or pressure sensor after operation has started.</p> <p>⊙ Judgment time : Approx. 15 minutes after activation</p> <ul style="list-style-type: none"> • Cooling : When changed value of TC1 is 5°C or less. • Heating : When changed value of pressure sensor is 0.5MPa or less. 	<ul style="list-style-type: none"> • Check miswiring of indoor unit which alarm is displayed. • Check for blockage in pipe of indoor unit which alarm is displayed. • Check refrigerant shortage. <p>[NOTE] When checking miswiring, follow the items below. Otherwise, misjudgment may be caused.</p> <p>1) Check miswiring after outdoor unit stops 20 minutes or more. Microprocessor is locked so that miswiring check function does not operate forcibly for 2 minutes and 30 seconds after power has been turned on.</p> <p>2) Check miswiring under the following conditions.</p> <table border="0"> <tr> <td>In cooling</td> <td>Room temp.</td> <td>: 18 to 32°C</td> </tr> <tr> <td></td> <td>Outside temp.</td> <td>: 15 to 43°C</td> </tr> <tr> <td>In heating</td> <td>Room temp.</td> <td>: 18 to 32°C</td> </tr> <tr> <td></td> <td>Outside temp.</td> <td>: -15 to 15°C</td> </tr> </table> <p>3) When group operation for other outdoor system is performed, miswiring check function cannot be used.</p>	In cooling	Room temp.	: 18 to 32°C		Outside temp.	: 15 to 43°C	In heating	Room temp.	: 18 to 32°C		Outside temp.	: -15 to 15°C
In cooling	Room temp.	: 18 to 32°C															
	Outside temp.	: 15 to 43°C															
In heating	Room temp.	: 18 to 32°C															
	Outside temp.	: -15 to 15°C															
9F	Indoor	Indoor PMV blockage	Judgment of refrigerant circulation volume shortage	<p>Status that refrigerant did not flow in indoor unit was detected.</p> <ul style="list-style-type: none"> • Compared with TA temp., TC1 and TC2 temp. are continuously below 4°C for 60 minutes. 	<ul style="list-style-type: none"> • Check indoor PMV open valve opening status. • Check characteristics of TC1, TC2, and TA sensor resistant value. • Check indoor pressure sensor error. • Check indoor PMV connector and wiring. • Check for breakage and blockage of pipe. • Check operation status of outdoor compressor. (When outdoor fan operates and compressor stops, error is judged at indoor side. In this case, check outdoor side.) 												
A0	Interface	TD1 sensor alarm	Discharge temp. sensor (TD1)	Sensor resistance value is infinity or zero (Open, Short).	<ul style="list-style-type: none"> • Check connection of TD1 sensor connector. • Check characteristics of TD1 sensor resistance value. • Check outdoor P.C. board (Interface) error. 												
A1	Interface	TD2 sensor alarm	Discharge temp. sensor (TD2)	Sensor resistance value is infinity or zero (Open, Short).	<ul style="list-style-type: none"> • Check connection of TD2 sensor connector. • Check characteristics of TD2 sensor resistance value. • Check outdoor P.C. board (Interface) error. 												
A2	Interface	TS1 sensor alarm	Suction temp. sensor (TS1)	Sensor resistance value is infinity or zero (Open, Short).	<ul style="list-style-type: none"> • Check connection of TS1 sensor connector. • Check characteristics of TS1 sensor resistance value. • Check outdoor P.C. board (Interface) error. 												

Check code	Detected position	Check code name	Cause (Position)	Trouble detection condition	Check item (Position)
A6	Interface	Discharge temp. TD1 alarm	Discharge temp. (TD1) protective operation	Protective stop was repeated for more than three times when discharge temp. TD1 exceeded 130°C.	<ul style="list-style-type: none"> • Check outdoor service valve (Gas side, liquid sides) fully open. • Check for blockage of outdoor PMV. <ol style="list-style-type: none"> 1) Refrigerant choke circuit (PMV A) 2) Cooling bypass circuit (PMV B) 3) Liquid line check valve (Cooling only model) • Check characteristics of TD1 sensor resistance value. • Check 4-way valve error.
A7	Interface	TS condition gas leak detection	Suction temp. protective operation (TS1)	Protective stop when status suction temp. TS is above the criteria temp. continues for 10 minutes and repeats for three times or more. <TS alarm criteria temp.> In cooling : 60°C or more In heating : 40°C or more	<ul style="list-style-type: none"> • Check refrigerant shortage. • Check outdoor service valve (gas side, liquid sides) fully open. • Check for blockage of outdoor PMV. <ol style="list-style-type: none"> 1) Refrigerant choke circuit (PMV A) 2) Cooling bypass circuit (PMV B) 3) Liquid line check valve (Cooling only model) • Check characteristics of TS1 resistance value. • Check 4-way valve error.
AA	Interface	Pd sensor alarm	High-pressure Pd sensor	Pd sensor output voltage is zero (Sensor open).	<ul style="list-style-type: none"> • Check connection of Pd sensor connector. • Check Pd sensor error. • Check outdoor P.C. board (Interface) error.
Ab	Interface	Mis-connection of pressure sensor	Miswiring of pressure sensor (Pd, Ps)	<ul style="list-style-type: none"> • High-pressure Pd sensor and Low-pressure Ps sensor were exchanged. • Output voltage of both sensors are zero. 	<ul style="list-style-type: none"> • Check connection of high-pressure Pd sensor connector. • Check connection of low-pressure Ps sensor connector. • Check pressure sensor Pd and Ps error. • Check outdoor P.C. board (Interface) error. • Check miswiring of fixed-speed compressor terminal. (Inverse operation of fixed-speed scroll compressor) • Check compressor compressing error.
AE	Interface	Detection of TD1 condition gas leak	Discharge temp. up when small capacity of indoor operates. (TD1)	Protective stop when discharge temp. TD1 detected 110°C or more under condition that inverter compressor operated with low frequency and repeats for three times.	<ul style="list-style-type: none"> • Check refrigerant shortage. • Check 4-way valve error. • Check for blockage of outdoor PMV. <ol style="list-style-type: none"> 1) Refrigerant choke circuit (PMV A) 2) Cooling bypass circuit (PMV B) 3) Liquid line check valve (Cooling only model) • Check characteristics of TD1 sensor resistance value. • Check for blockage of indoor filter. • Check for blockage of pipe.
AF	Interface	Phase order alarm	Miswiring of phase order or missing one phase of outdoor	Phase order error or missing one phase was detected when power was turned on.	<ul style="list-style-type: none"> • Check phase order missing phase of outdoor power supply wiring. • Check outdoor P.C. board (Interface) error.
b4	Interface	Ps sensor alarm	Low-pressure Ps sensor	<ul style="list-style-type: none"> • Ps sensor output voltage was zero. • Ps pressure detected continuously 0.95MPa or less during operation. 	<ul style="list-style-type: none"> • Misconnection of connector between Pd sensor and Ps sensor. • Check connection of Ps sensor. • Check Ps sensor error. • Check compressor error. • Check 4-way valve error. • Check outdoor P.C. board (Interface) error.

Check code	Detected position	Check code name	Cause (Position)	Trouble detection condition	Check item (Position)
b5	Indoor	Indoor outside input alarm	Alarm display by outside input	By voltage V_{emg} to be input in outside alarm input terminal ($V_{emg} < 1.25V$ was detected for 60 seconds.)	<ul style="list-style-type: none"> When outside equipment is connected to connector (CN21) <ol style="list-style-type: none"> Check outside equipment error. Check indoor P.C. board error. When outside equipment is not connected to connector (CN21) <ol style="list-style-type: none"> Check indoor P.C. board.
b6	Indoor	Indoor outside interlock	Display of outside interlock input	<ul style="list-style-type: none"> By voltage value V_{emg} to be input in outside alarm input terminal ($V_{emg} < 3.75V$ was detected for 60 seconds.) 	<ul style="list-style-type: none"> When outside equipment is connected to connector (CN21) (Indoor main P.C. board (MCC-1361)). <ol style="list-style-type: none"> Check outside equipment error. Check failure of indoor main P.C. board (MCC-1361). When outside equipment is not connected to connector (CN21) (Indoor main P.C. board (MCC-1361)). <ol style="list-style-type: none"> Check indoor main P.C. board (MCC-1361).
b7	Indoor	Indoor unit No. 2 to 16 in grouping	Indoor unit alarm in group operating	Server unit error in group operating	Check each indoor unit with the remote controller
b9	Indoor	Indoor pressure sensor alarm	Indoor pressure sensor	Indoor pressure sensor output was zero. (After judgment, operation transmits to automatic backup operation.)	<ul style="list-style-type: none"> Check connection and wiring of connector (CN23) of indoor pressure sensor and indoor main P.C. board (MCC-1361). Check indoor pressure sensor error. Check failure of indoor main P.C. board (MCC-1361).
bb	Interface	Discharge temp. TD2 alarm	Discharge temp. (TD2) protection	The protective stop when discharge temp. TD2 exceeded $130^{\circ}C$ and repeats for 3 times or more.	<ul style="list-style-type: none"> Check service valves. (Gas side, Liquid side are fully open.) Check for blockage of outdoor PMV. <ol style="list-style-type: none"> Refrigerant choke circuit (PMV A) Cooling bypass circuit (PMV B) Liquid line check valve (Cooling only model) Check TD2 sensor resistance value characteristics Check refrigerant shortage, piping blockage
bd	Interface	Mg-SW deposit protective operation	Fixed-speed Mg-SW deposit protective control is operating.	<p>30 seconds passed after outdoor (compressor) stops,</p> <ol style="list-style-type: none"> Discharge temp. $135^{\circ}C$ for fixed-speed compressor was detected. P_s pressure $< 0.02MPa$ and $TD \geq 60^{\circ}C$ were detected. P_d pressure $\geq 3.2MPa$ and $TD \geq 80^{\circ}C$ were detected. <p>[NOTE]</p> <p>During control operation, if high pressure P_d becomes $3.2MPa$ or more, the outdoor fan operates.</p> <p>The indoor PMV and outdoor PMV are forcibly opened, and the cooling cycle is formed.</p>	<ul style="list-style-type: none"> Check contact of the fixed-speed Mg-SW. Check for refrigerant shortage. Check discharge temp. TD sensor error at fixed-speed unit side. Check P_d and P_s pressure sensors error.

Check code	Detected position	Check code name	Cause (Position)	Trouble detection condition	Check item (Position)
bE	Interface	Low pressure protective operation	Protection when low pressure Ps lowered.	Low pressure Ps detected lower than 0.02MPa.	<ul style="list-style-type: none"> • Check for refrigerant shortage. • Check outdoor service valves. (Gas side, Liquid side are fully open.) • Check for blockage of outdoor PMV. <ul style="list-style-type: none"> 1) Refrigerant choke circuit (PMV A) 2) Liquid line check valve (Cooling only model) • Check discharge temp. TD sensor error. • Check low pressure Ps sensor error. • Check indoor filter blockage. • Check refrigerant pipe blockage. • Check outdoor fan operation. (In heating)
cF	Indoor	Communication error between indoor MCU	Lead wire between indoor main P.C. board (MCC-1361) and indoor motor P.C. board (MCC-1382)	Communication between MCU interrupted for 50 seconds.	<ul style="list-style-type: none"> • Check connection between connector (CN28) of indoor main P.C. board (MCC-1361) and connector (CN27) of indoor motor P.C. board (MCC-1382). • Check failure of indoor main P.C. board (MCC-1361). • Check failure of indoor motor P.C. board (MCC-1382).
d1	Interface	Outdoor inverter set up alarm	Outdoor inverter units are duplicated.	There were multiple outdoor inverter units in 1 line.	<ul style="list-style-type: none"> • Check No. of connected inverter outdoor units. • Check SW08/bit 2 set up on outdoor P.C. board (interface). • Check outdoor P.C. board (interface).
d2	Interface	Fixed-speed outdoor unit alarm	Fixed-speed outdoor unit protection	Inverter outdoor unit received an alarm code from fixed-speed outdoor.	<ul style="list-style-type: none"> • Check the check code of fixed-speed outdoor unit. • Convenient functions If keeping SW04 pushed for 5 seconds or more under condition that [d2] is displayed on the 7 segment display of the inverter outdoor, fan of the outdoor unit which stops in emergency operates. If keeping SW04 and SW05 pushed concurrently, the normal outdoor unit fan operates. If pushing SW05 alone, the fan operation is released.
d3	Inverter	TH sensor alarm	Temp. sensor (TH) to detect overheating of IPDU microprocessor	Sensor resistance value was infinity or zero (Open, Short).	<ul style="list-style-type: none"> • Temp. sensor incorporated with IGBT has failed. → Replace IPDU P.C. board.
d4	Interface	TK1 sensor alarm	Temp. sensor (TK1) to detect oil level	Sensor resistance value was infinity or zero (Open, Short).	<ul style="list-style-type: none"> • Check connector connection of TK1 sensor. • Check characteristics of TK1 sensor resistance value. • Check outdoor P.C. board (interface) error.
d5	Interface	TK2 sensor alarm	Temp. sensor (TK2) to detect oil level	Sensor resistance value was infinity or zero (Open, Short).	<ul style="list-style-type: none"> • Check connector connection of TK2 sensor. • Check characteristics of TK2 sensor resistance value. • Check outdoor P.C. board (interface) error.

Check code	Detected position	Check code name	Cause (Position)	Trouble detection condition	Check item (Position)
d6	Interface	TK3 sensor alarm	Temp. sensor (TK3) to detect oil level	Sensor resistance value was infinity or zero (Open, Short).	<ul style="list-style-type: none"> • Check connector connection of TK3 sensor. • Check characteristics of TK3 sensor resistance value. • Check outdoor P.C. board (interface) error.
d7	Interface	Low oil level detection protection	Oil level detection circuit	Oil shortage status was continuously detected for approx. 2 hours while oil equalizing control was continuously executed.	<p><Check all outdoor units in the line.></p> <ul style="list-style-type: none"> • Check the valve to remove oil in compressor case. • Check for blockage in oil separator and oil return circuits. • Check for blockage in balancing pipe valve and pipe between outdoor units. • Check misconnection of TK1, TK2, and TK3. • Check characteristics of TK2 sensor resistance value. • Check leakage of reducing valve (SV3A). • Check leakage of pressurize valve (SV3C). • Check for blockage of oil return valve (SV3B). • Check peripheral circuits of oil tank. <ul style="list-style-type: none"> 1) Leakage of check valve 2) Blockage of capillary • Check for substantial refrigerant stagnation in compressor case. <ul style="list-style-type: none"> 1) Check leakage of cooling bypass circuit (PMV3).
d8	Interface	TK1 temp. detection circuit alarm	Oil level detection circuit	Temp. change at primary side of oil tank was not detected when oil level detection control was executed.	<ul style="list-style-type: none"> • Check out of place of TK1 pipe sensor. • Check characteristics of TK1 sensor resistance value. • Check misconnection of TK1, TK2, and TK3.
d9	Interface	TK2 temp. detection circuit alarm	Oil level detection circuit	Temp. change at secondary side of oil tank was not detected when oil level detection control was executed.	<ul style="list-style-type: none"> • Check out of place of TK2 pipe sensor. • Check characteristics of TK2 sensor resistance value. • Check peripheral circuits of oil tank. <ul style="list-style-type: none"> 1) Leakage of stop valve 2) Blockage of capillary 3) Blockage of strainer 4) Check contact of TK2 sensor circuit with discharge pipe. • Check misconnection of TK1, TK2, and TK3.
dA	Inverter	Heat sink overheating alarm	IGBT overheating protection	Overheating of IGBT was detected.	<ul style="list-style-type: none"> • Check IGBT error. (IGBT built-in temp. sensor error) • Check error of outdoor fan system. • Check for blockage in cooling duct of heat sink. • Check mounting failure of IGBT heat sink.
db	Interface	Oil level detection circuit blockage detection	Oil level detection circuit	Temp. change at primary and secondary sides of oil tank was not detected when oil level detection control was executed.	<ul style="list-style-type: none"> • Check for blockage of peripheral circuits of pressurize valve (SV3C). • Check connection of SV3C valve coil and connector.
dC	Interface	Oil level detection circuit leakage detection	Oil level detection circuit	The status that TK1 temp. is high (50°C or more) was continuously detected for a long time.	<ul style="list-style-type: none"> • Check leakage of pressurize valve (SV3C). • Check characteristics of TK1 sensor resistance value. • Check operation out of use temp. range of outdoor unit. (Cooling overload operation, etc.)

Check code	Detected position	Check code name	Cause (Position)	Trouble detection condition	Check item (Position)
dd	Interface	Outdoor refrigerant leakage detection	Outdoor liquid line interrupt circuit	<ul style="list-style-type: none"> The status that pressure value is high was detected in the stopped fixed-speed outdoor unit when the system operated in COOL mode. The status that PMV opening degree is the minimum 100P is continued for a long time during S.H control while the system is operated in HEAT mode. 	<ul style="list-style-type: none"> Check preceding close operation of outdoor PMV A (PMV 1 and PMV 2). Liquid line check valve (Cooling only model) Check for blockage of gas balance circuit (SV2). Check capillary for bypass between fixed-speed outdoor gas pipe and heat exchange line. Check for blockage of oil return circuit (SV3B peripheral circuits). <ol style="list-style-type: none"> Blockage of check valve Blockage of capillary Blockage of SV3B (Check all outdoor units.) Blockage of balancing pipe (Check pipe between outdoor units.) Check for blockage of oil return capillary of oil separator. Check 4-way valve error. Check outdoor P.C. board (interface) error.
dE	Indoor	Indoor address undefined	During automatic indoor address	There was undefined address in the indoor addresses.	<ul style="list-style-type: none"> * Wait for a while during display. When the address is defined, the operation is automatically reset. * If the check code does not disappear 20 minutes after turning on the power, it is abnormal. Check the following items. Check failure of indoor main P.C. board (MCC-1361). Check communication noise source. Check Incorrect set up of jumper on indoor main P.C. board (MCC-1361)
dF	Interface	Outdoor address undefined	During automatic outdoor address	There was undefined address in the outdoor addresses.	<ul style="list-style-type: none"> * Wait for a while during display. When the address is defined, the operation is automatically reset. * If the check code does not disappear 5 minutes after turning on the power, it is abnormal. Check the following items. Check indoor P.C. board (interface) error. Check communication noise source.
E1	Interface	Fixed-speed high pressure SW system alarm (1)	Fixed-speed high pressure SW system circuit (Compress or 1)	<p>High pressure SW circuit or IOL, OCR system circuit operated.</p> <ul style="list-style-type: none"> When high pressure Pd \geq 2.5MPa, [High pressure SW system error] <ol style="list-style-type: none"> In case of compressor 1 : [E1] is displayed. In case of compressor 2 : [F0] is displayed. When high pressure Pd < 2.5MPa, [IOL, OCR system error] <ol style="list-style-type: none"> In case of compressor 1 : [E6] is displayed. In case of compressor 2 : [F1] is displayed. 	<ul style="list-style-type: none"> Check high pressure SW error of compressor 1, and check IOL, OCR operation. Check IOL operation of compressor 1 and case temp. up. (Check cause of overload operation.) Check operation and blockage of SV41 valve. Check if service valve is fully open. Check outdoor fan operation and connector connection. Check outdoor fan motor and running capacitor error. Check for blockage of outdoor PMV. <ol style="list-style-type: none"> Refrigerant choke circuit (PMV A) Cooling bypass circuit (PMV B) Liquid line check valve (Cooling only model) Check for blockage of indoor/outdoor heat exchanger. Check Pd pressure sensor error. Check for blockage of hot gas bypass SV2 circuit. Check outdoor P.C. board (interface) error. Check indoor fan error. (Cause of air volume down) Check indoor PMV open valve status. Check miswiring between indoor/outdoor communication line.

Check code	Detected position	Check code name	Cause (Position)	Trouble detection condition	Check item (Position)
E5	Interface	Inverter IOL operation	Inverter IOL system circuit	<p>Inverter IOL or high pressure SW operated.</p> <ul style="list-style-type: none"> ■ When high pressure Pd \geq 2.5MPa, [21] is displayed. ■ When high pressure Pd < 2.5MPa, [E5] is displayed. 	<ul style="list-style-type: none"> • Check inverter high pressure SW error. • Check inverter IOL operation and case temp. • Check overload operation cause and refrigerant shortage. • Check if service valve is fully open. • Check indoor fan and connector connection. • Check outdoor fan motor and running capacitor error. • Check for blockage of outdoor PMV. <ul style="list-style-type: none"> 1) Refrigerant choke circuit (PMV A) 2) Cooling bypass circuit (PMV B) 3) Liquid line check valve (Cooling only model) • Check for blockage of indoor/outdoor heat exchanger. • Short-circuit status of outdoor discharge air suction air • Check Pd pressure sensor error. • Check for blockage of hot gas bypass SV2 circuit. • Check outdoor P.C. board (interface) error. • Check indoor fan error. (Cause of air volume down) • Check indoor PMV opening pulse. • Check miswiring between indoor/outdoor communication line.
E6	Interface	Fixed-speed side IOL, OL system alarm (1)	Fixed-speed side IOL, OCR system circuit (Compressor 1)	<p>Fixed-speed side IOL, OCR system or high pressure SW operated.</p> <ul style="list-style-type: none"> ■ When high pressure Pd \geq 2.5MPa, [High pressure SW system error] <ul style="list-style-type: none"> 1) In case of compressor 1 : [E1] is displayed. 2) In case of compressor 2 : [F0] is displayed. ■ When high pressure Pd < 2.5MPa, [IOL, OCR system error] <ul style="list-style-type: none"> 1) In case of compressor 1 : [E6] is displayed. 2) In case of compressor 2 : [F1] is displayed. 	<ul style="list-style-type: none"> • Check high pressure SW error of compressor 1, and check IOL, OCR operation. • Check IOL operation of compressor 1 and case temp. up. (Check cause of overload operation.) • Check operation and blockage of SV41 valve. • Check if service valve is fully open. • Check outdoor fan operation and connector connection. • Check outdoor fan motor and running capacitor error. • Check for blockage of outdoor PMV. <ul style="list-style-type: none"> 1) Refrigerant choke circuit (PMV A) 2) Cooling bypass circuit (PMV B) 3) Liquid line check valve (Cooling only model) • Check for blockage of indoor/outdoor heat exchanger. • Check Pd pressure sensor error. • Check for blockage of hot gas bypass SV2 circuit. • Check outdoor P.C. board (interface) error. • Check indoor PMV opening pulse. • Check miswiring between indoor/outdoor communication line.
Eb	Interface	Outside indoor alarm input	Outside alarm input signal [b6] is receiving from indoor.	<ul style="list-style-type: none"> • According to voltage input in the outside input terminal of indoor P.C. board • The check code [b6] is received from indoor unit. 	<ul style="list-style-type: none"> • When outside device is connected to connector (CN17) <ul style="list-style-type: none"> 1) Check outside device error. 2) Check failure of indoor main P.C. board (MCC-1361) • When outside device is not connected to connector (CN17) <ul style="list-style-type: none"> 1) Check indoor main P.C. board (MCC-1361)

Check code	Detected position	Check code name	Cause (Position)	Trouble detection condition	Check item (Position)
F0	Interface	Fixed-speed high pressure SW system alarm (2)	Fixed-speed high pressure SW system circuit (Compressor 2)	<p>High pressure SW circuit or IOL, OCR system circuit operated.</p> <ul style="list-style-type: none"> ■ When high pressure Pd \geq 2.5MPa, [High pressure SW system error] <ul style="list-style-type: none"> 1) In case of compressor 1 : [E1] is displayed. 2) In case of compressor 2 : [F0] is displayed. ■ When high pressure Pd < 2.5MPa, [IOL, OCR system error] <ul style="list-style-type: none"> 1) In case of compressor 1 : [E6] is displayed. 2) In case of compressor 2 : [F1] is displayed. 	<ul style="list-style-type: none"> • Check high pressure SW error of compressor 2, and check IOL, OCR operation. • Check IOL operation of compressor 2 and case temp. (Check cause of overload operation.) • Check operation and for blockage of SV42 valve. • Check service valve is fully open. • Check outdoor fan operation and connector connection. • Check outdoor fan motor and running capacitor error. • Check for blockage of outdoor PMV. <ul style="list-style-type: none"> 1) Refrigerant choke circuit (PMV A) 2) Cooling bypass circuit (PMV B) 3) Liquid line check valve (Cooling only model) • Check for blockage of indoor/outdoor heat exchanger. • Check Pd pressure sensor error. • Check for blockage of hot gas bypass SV2 circuit. • Check outdoor P.C. board (interface) error. • Check indoor PMV opening pulse. • Check miswiring between indoor/outdoor communication line.
F1	Interface	Fixed-speed side IOL, OL system alarm (2)	Fixed-speed side IOL, OCR system circuit (Compressor 2)	<p>Fixed-speed side IOL, OCR system or high pressure SW operated.</p> <ul style="list-style-type: none"> ■ When high pressure Pd \geq 2.5MPa, [High pressure SW system error] <ul style="list-style-type: none"> 1) In case of compressor 1 : [E1] is displayed. 2) In case of compressor 2 : [F0] is displayed. ■ When high pressure Pd < 2.5MPa, [IOL, OCR system error] <ul style="list-style-type: none"> 1) In case of compressor 1 : [E6] is displayed. 2) In case of compressor 2 : [F1] is displayed. 	<ul style="list-style-type: none"> • Check high pressure SW error of compressor 2, and check IOL, OCR operation. • Check IOL operation of compressor 2 and case temp. (Check cause of overload operation.) • Check operation and for blockage of SV42 valve. • Check service valve is fully open. • Check outdoor fan operation and connector connection. • Check outdoor fan motor and running capacitor error. • Check for blockage of outdoor PMV. <ul style="list-style-type: none"> 1) Refrigerant choke circuit (PMV A) 2) Cooling bypass circuit (PMV B) 3) Liquid line check valve (Cooling only model) • Check for blockage of indoor/outdoor heat exchanger. • Check Pd pressure sensor error. • Check for blockage of hot gas bypass SV2 circuit. • Check outdoor P.C. board (interface) error. • Check indoor fan error. (Cause of air volume down) • Check indoor PMV opening pulse. • Check miswiring between indoor/outdoor communication line.

3-6-4. Diagnostic Procedure for Check Code

Check code	Operation cause
<p align="center">[04] Inverter communication alarm</p>	<ol style="list-style-type: none"> 1. Connection error of communication cable between IPDU and interface P.C. boards 2. Defective interface P.C. board 3. Defective IPDU P.C. board 4. Noise from outside

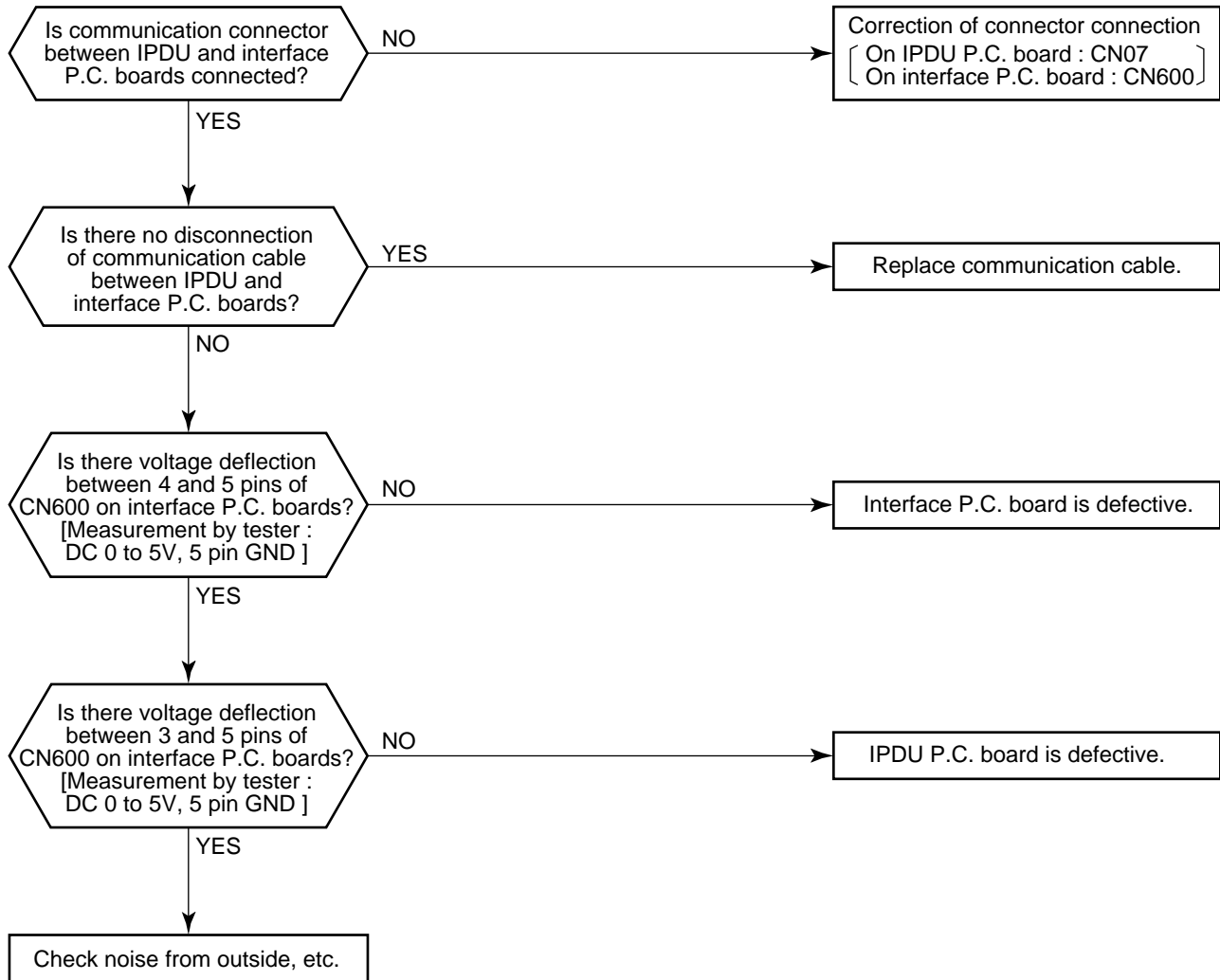

Check code	Operation cause
<p style="text-align: center;">[08] 4-way valve reversal alarm</p>	<ol style="list-style-type: none"> 1. 4-way valve operation error 2. TS1sensor/TE1 sensor error 3. Pd sensor/Ps sensor error 4. Fixed-speed compressor Mg-SW operation error

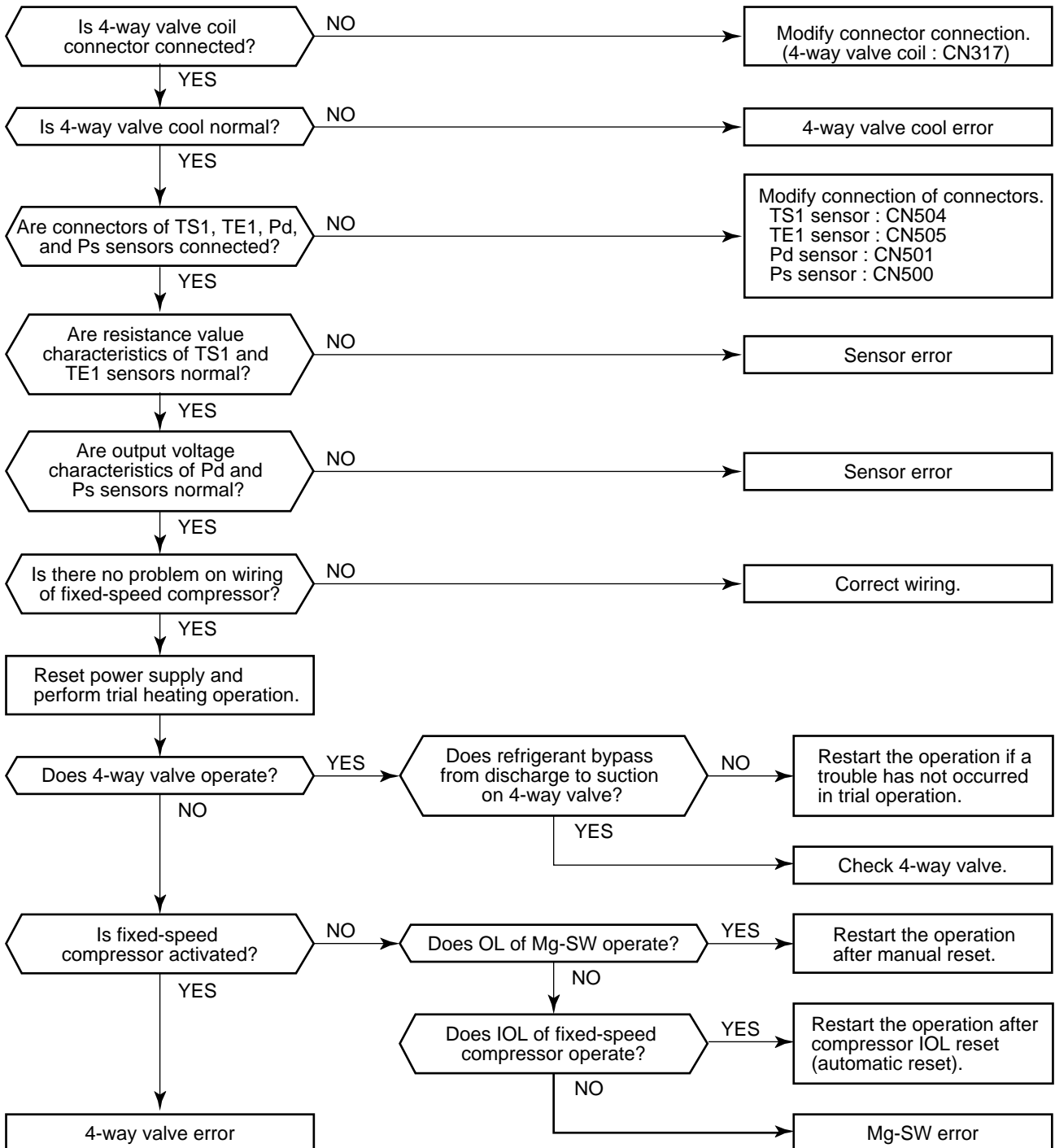

<For 4-way Air Discharge Cassette type>

Check code	Operation cause
[0b] Indoor water overflow alarm	1. Float switch disconnection 2. Drain pump operation error 3. Drain pipe blockage

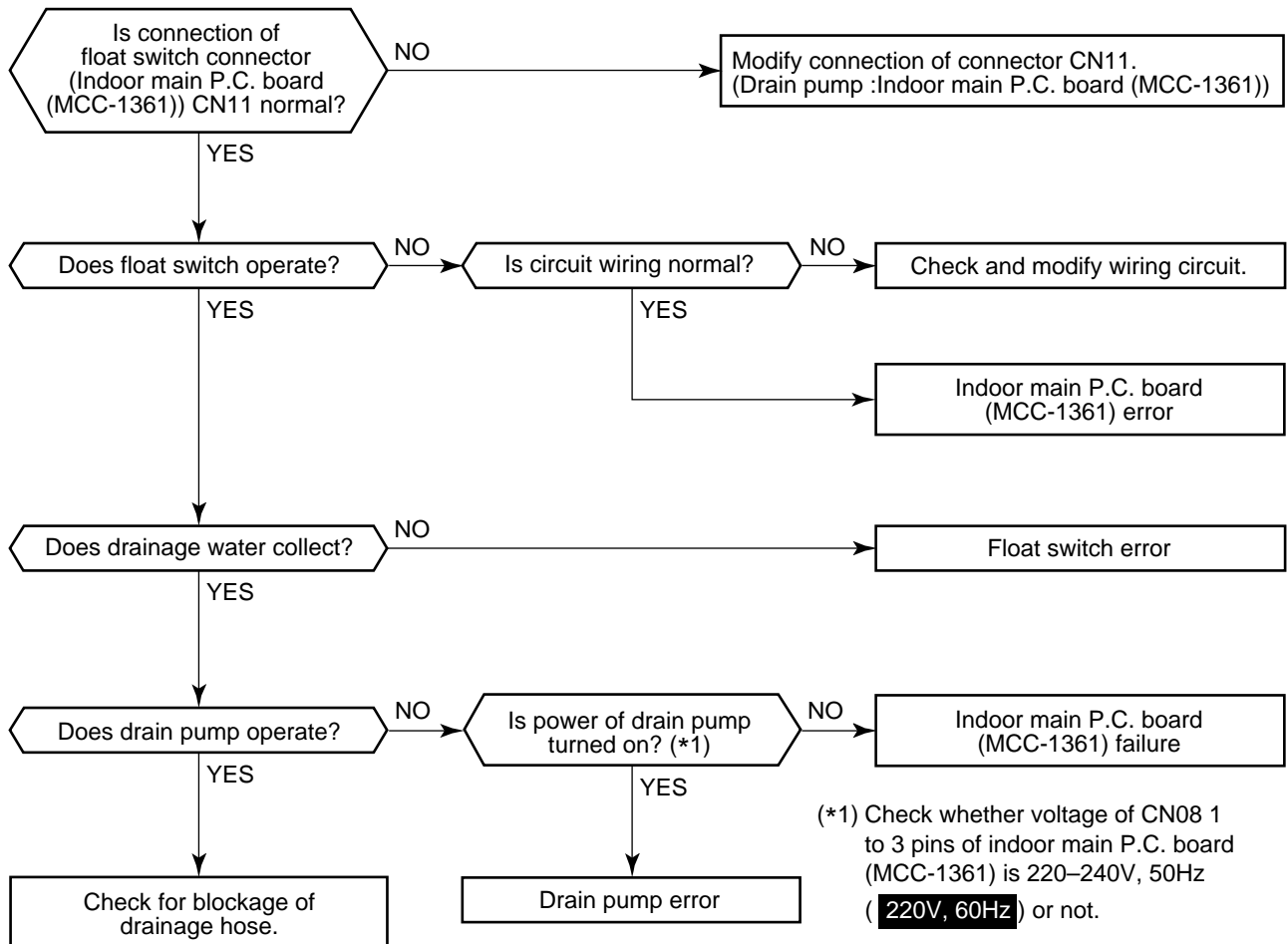

Check code	Operation cause
[0C] Indoor TA sensor alarm	TA sensor open/short

TA sensor open/short has been detected. Check disconnection of CN04 connector connection circuit (TA sensor : Indoor main P.C. board (MCC-1361) and characteristics of sensor resistance value. When the sensor is normal, replace indoor main P.C. board (MCC-1361)

<For 4-way Air Discharge Cassette type>

Check code	Operation cause
[11] Indoor fan motor alarm	1. Fan motor circuit connection error 2. Fan motor error 3. Indoor main P.C. board (MCC-1361) failure 4. Indoor motor P.C. board (MCC-1382) failure

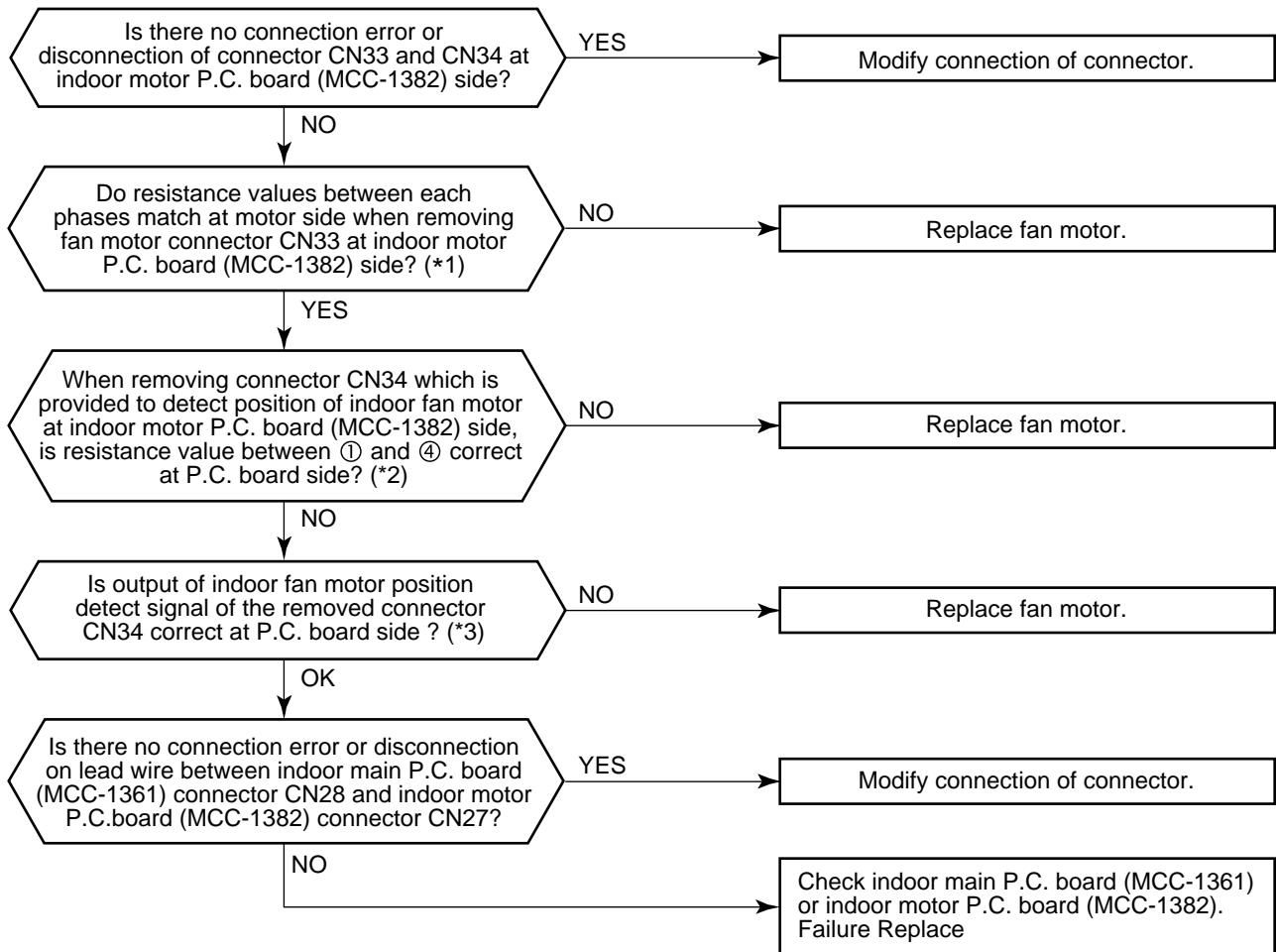

(*1) Resistance value check between motors

- Aren't windings open/short between ① and ②, ② and ③, ① and ③ → Resistance should be approx. 75Ω to 95Ω.
- Doesn't ground failure occur between cabinet and ①, ②, ③ 10MΩ or more should be applied.

(*2) Check of position detect resistance value of indoor fan motor

- Isn't the resistance between ① and ④ opened or shorted? → Resistance value should be between 5kΩ to 20kΩ.

(*3) Fan motor position detect signal check

- Using a tester, measure voltage between ① and ⑤ →
When turning the fan slowly with hands, voltage between each pins should swing from 0V to 5V.
- Between ⑤ and ④ : 5V

Check code	Operation cause
[12] Other indoor alarm	1. Irregularity of power supply 2. Noise of peripheral equipment 3. Indoor main P.C. board failure

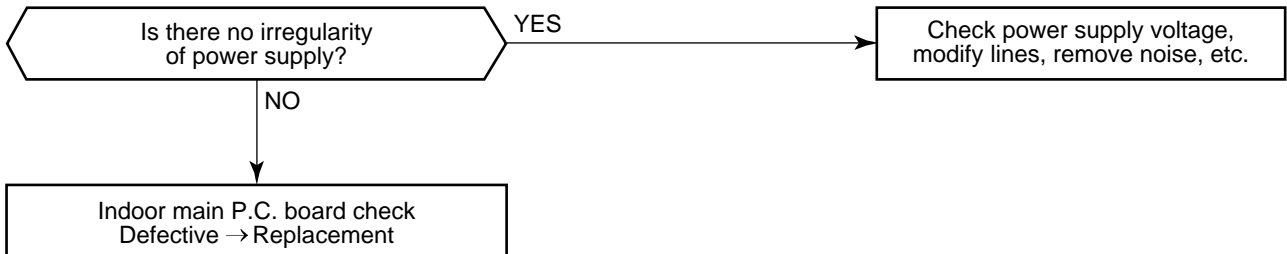

Check code	Operation cause
[14] G-Tr short circuit protective system alarm	1. Outdoor unit power supply error 2. Wiring error on IPDU P.C. board 3. AC fuse disconnection 4. Inverter compressor error 5. Defective IPDU P.C. board

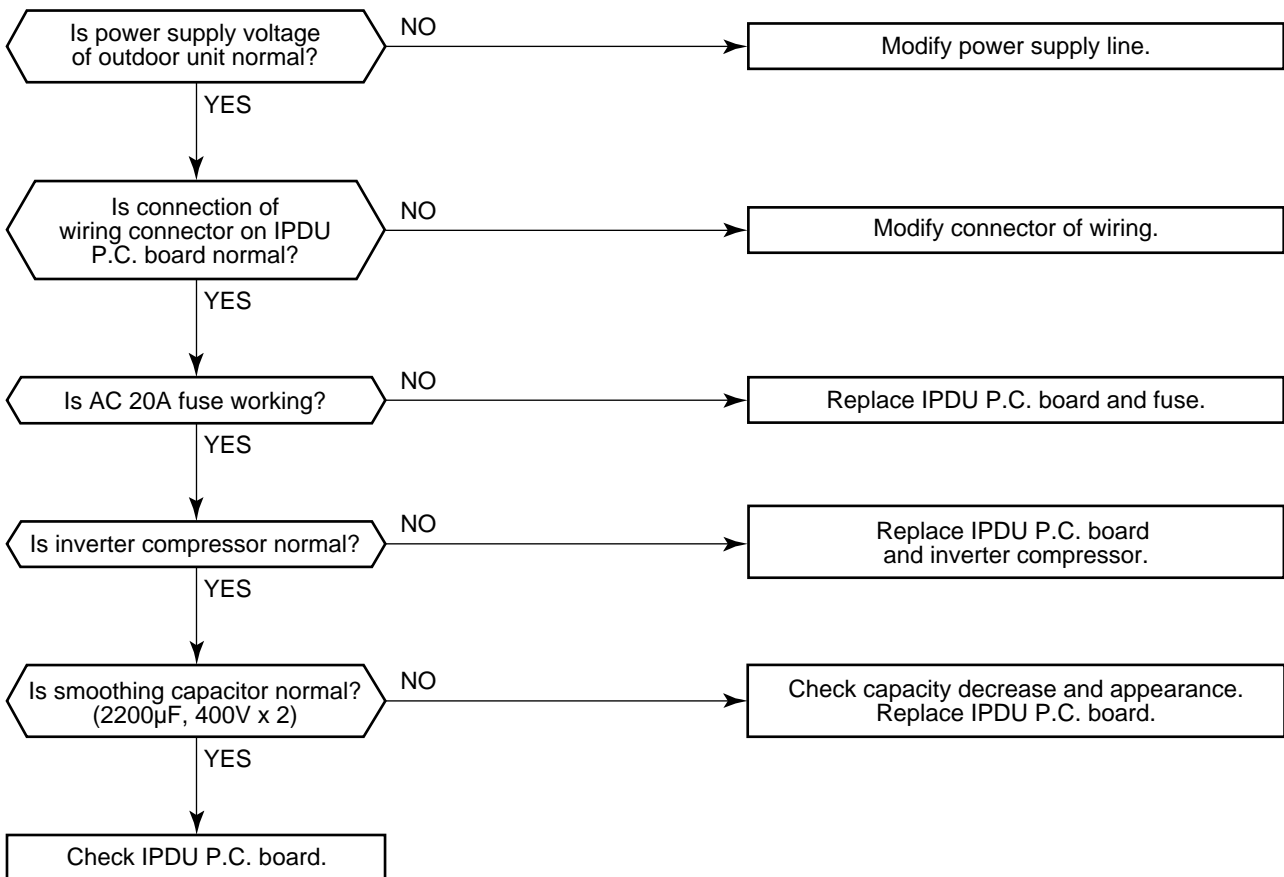

Check code	Operation cause
[17] Current detect circuit system alarm	1. Defective wiring of IPDU P.C. board 2. Defective IPDU P.C. board



Check code	Operation cause
[18] TE1 sensor alarm	TE1 sensor open/short

TE1 sensor open/short has been detected. Check disconnection of connector (TE1 sensor : CN505) circuit and resistance value characteristics of sensor.
When the sensors are normal, replace outdoor P.C. board.

Check code	Operation cause
[1C] Extension IC, EEPROM alarm	1. Outdoor unit power supply error 2. Interface P.C. board error



Check code	Operation cause
<p style="text-align: center;">[1d] Compressor alarm</p>	<ol style="list-style-type: none"> 1. Outdoor unit power supply error 2. Inverter compressor circuit system error 3. Inverter compressor error 4. Inverter compressor refrigerant stagnation 5. Defective IPDU P.C. board

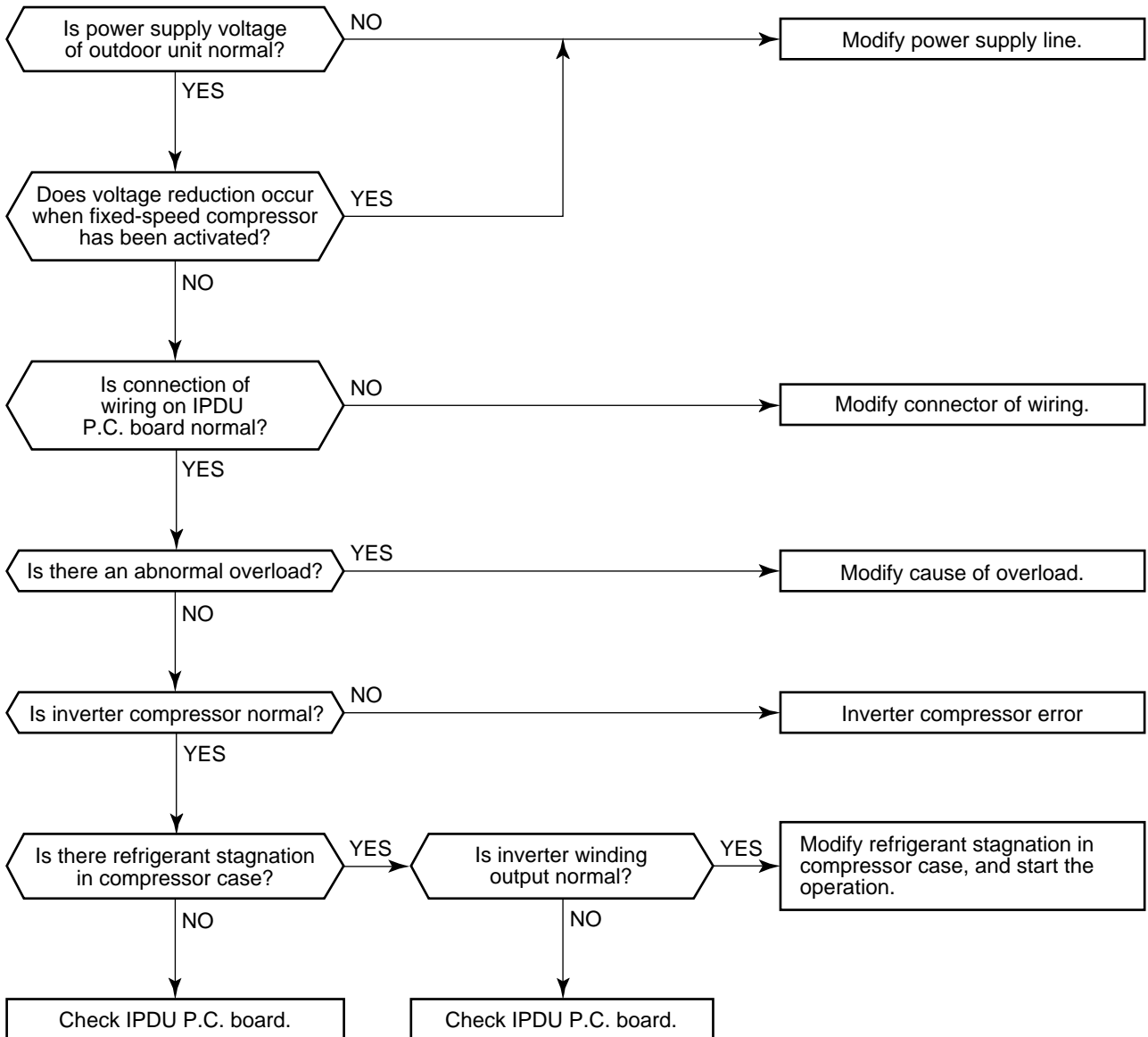

Check code	Operation cause
<p align="center">[1F] Compressor break down</p>	<p>1. Outdoor unit power supply error 2. Inverter compressor circuit system error 3. IPDU P.C. board error</p>

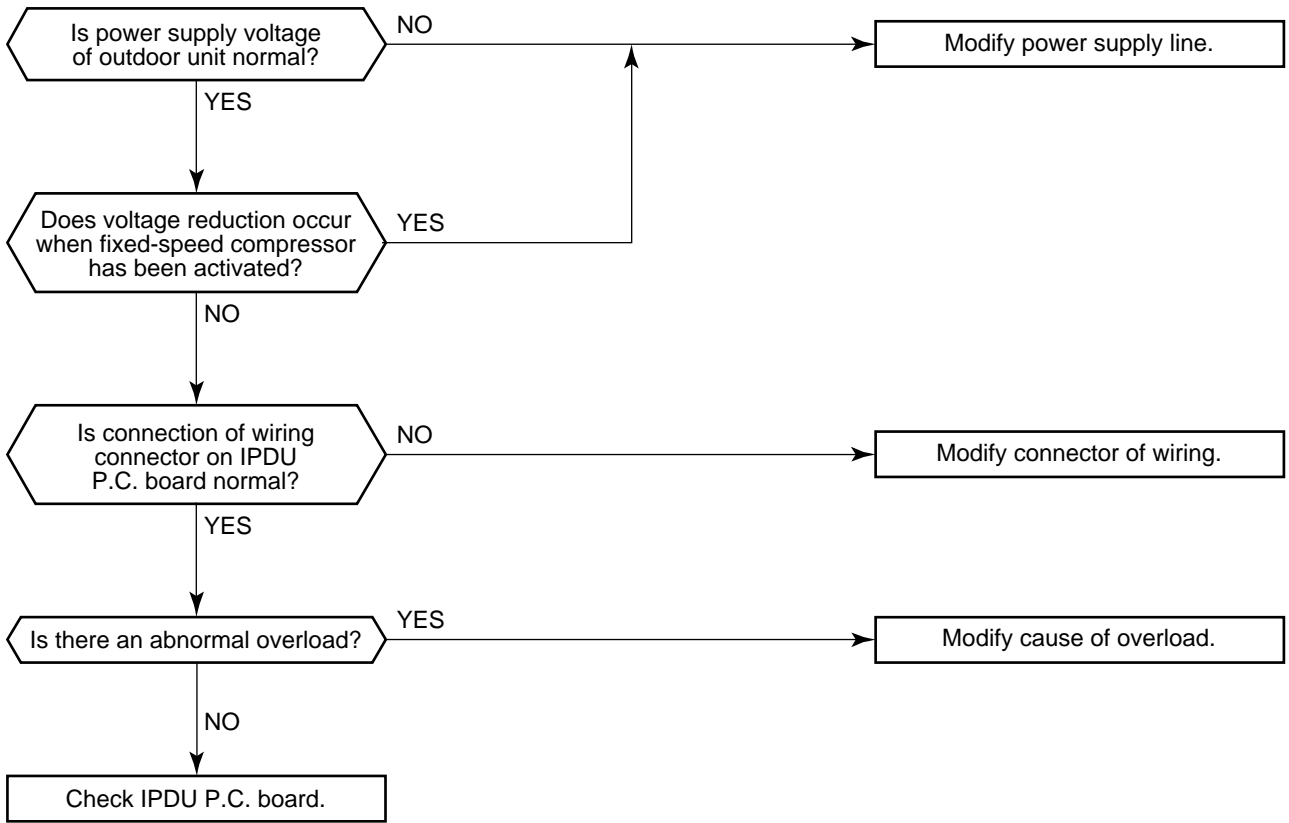

Check code	Operation cause
<p>[21] Inverter high-pressure SW system alarm</p>	<ol style="list-style-type: none"> 1. Inverter high-pressure SW error 2. Inverter IOL operation 3. Service valve closed 4. Outdoor fan, capacitor error 5. Indoor/Outdoor PMV blockage 6. Outdoor heat exchanger blockage 7. SV2 circuit blockage 8. Indoor - Outdoor communication error 9. Pd sensor error 10. Refrigerant over charge

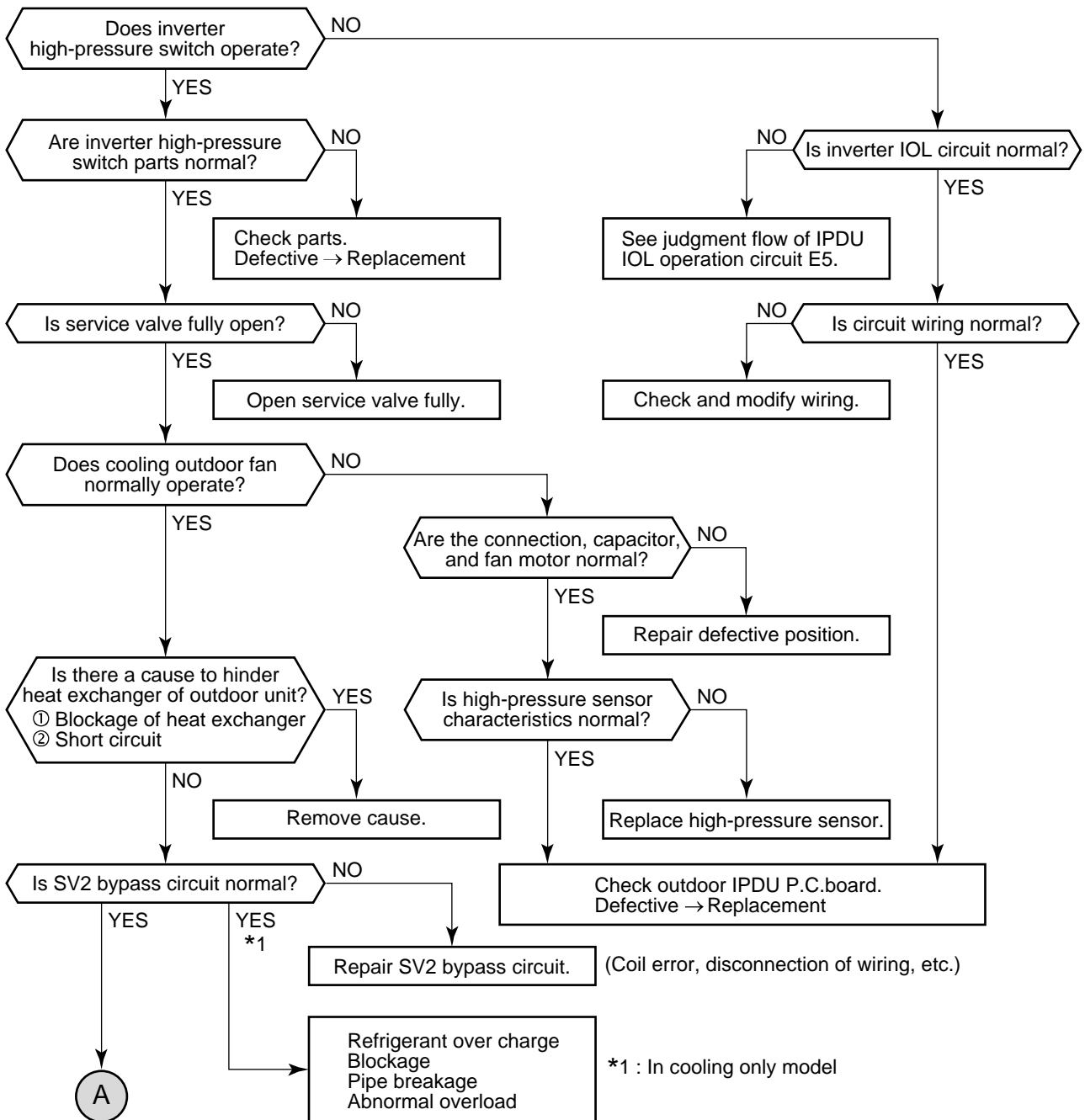

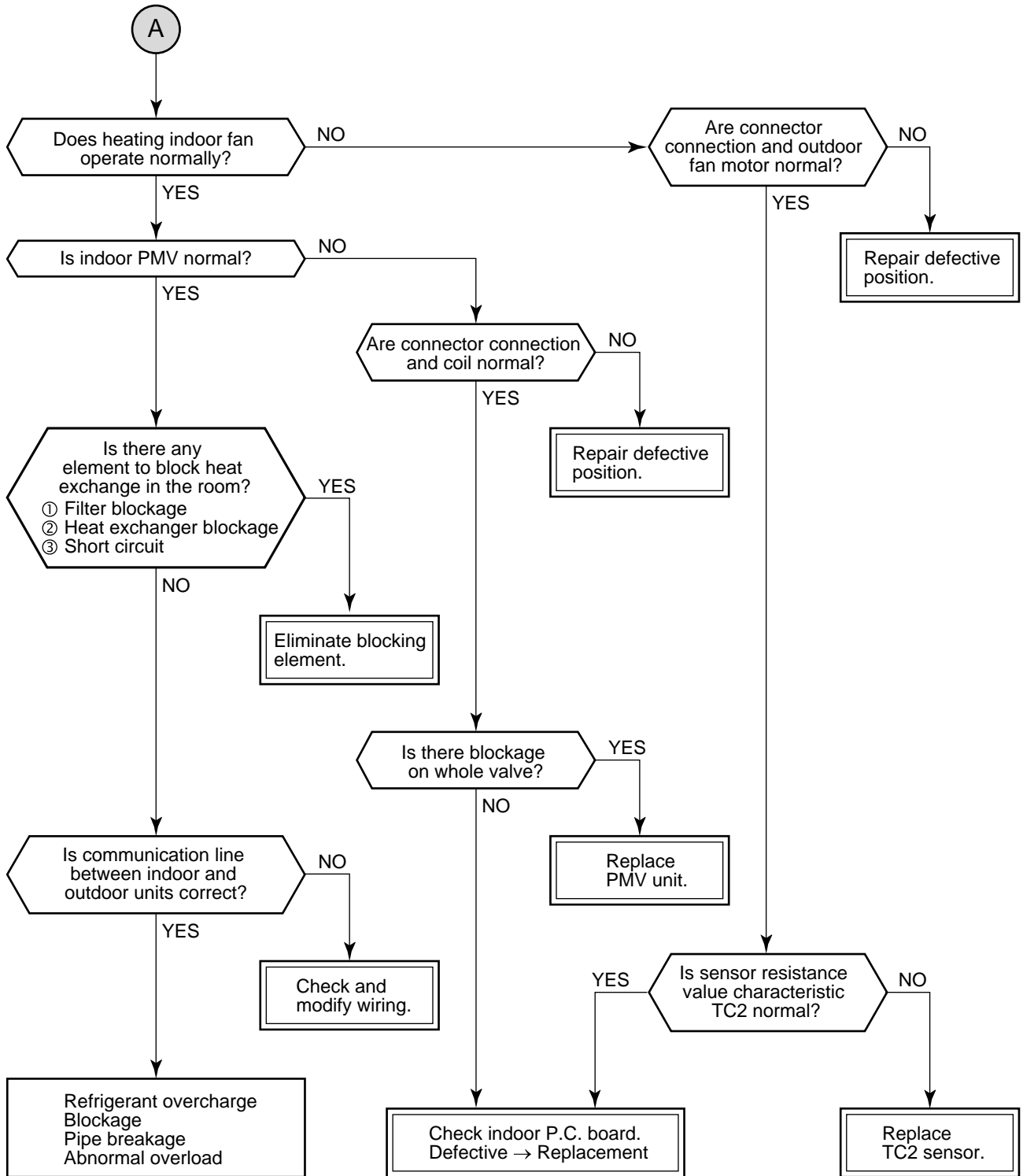

Check code	Operation cause
<p style="text-align: center;">[22] High-pressure protective operation</p>	<ol style="list-style-type: none"> 1. Pd sensor error 2. Service valve close 3. Outdoor fan, capacitor error 4. Indoor/Outdoor PMV blockage 5. Outdoor heat exchanger blockage 6. SV2 circuit blockage 7. Communication error between indoor and outdoor

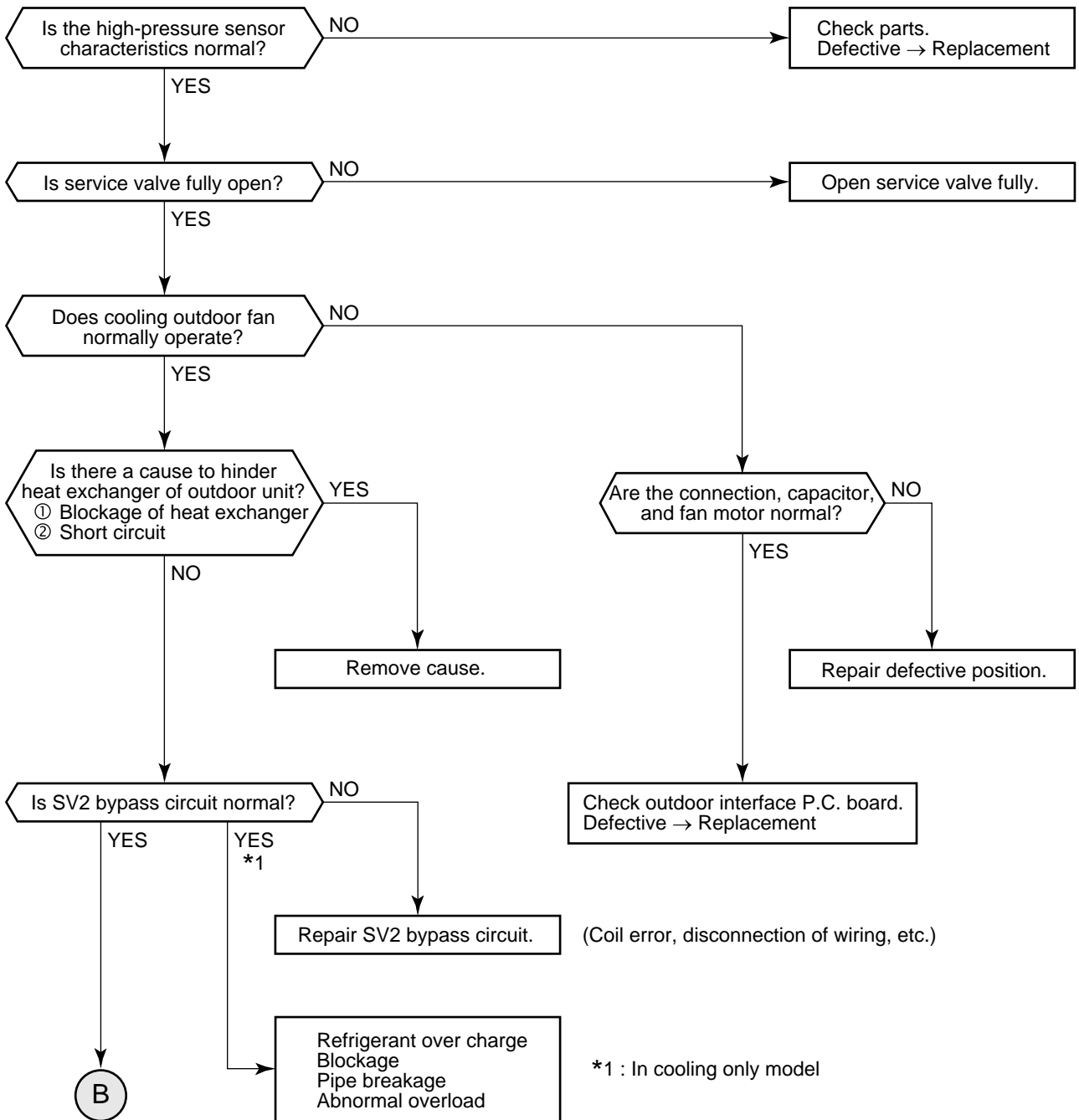

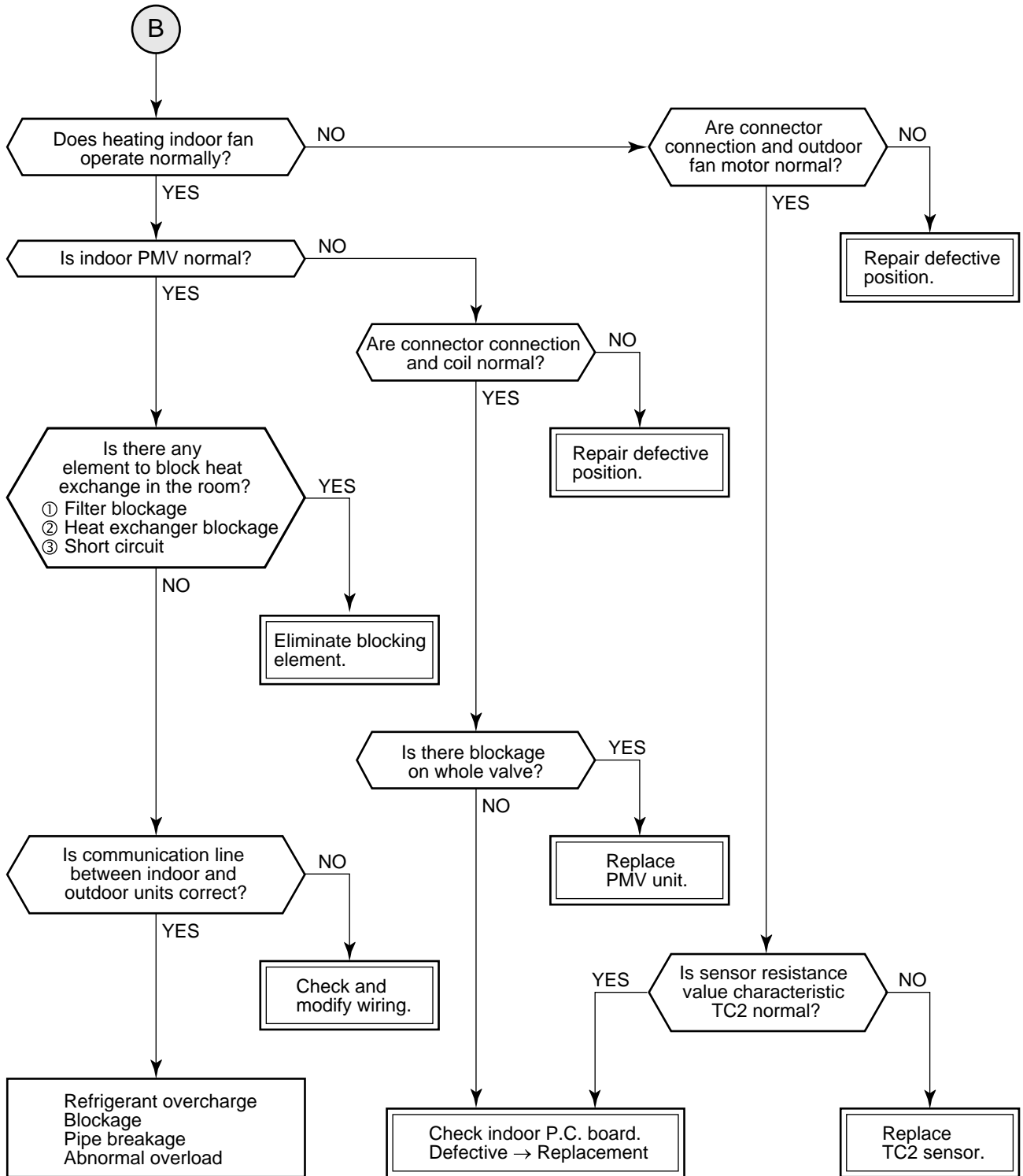

Check code	Operation cause
[89] Indoor over capacity	1. No. of connected indoor units/connected over capacity 2. Incorrect set up of indoor unit horse power

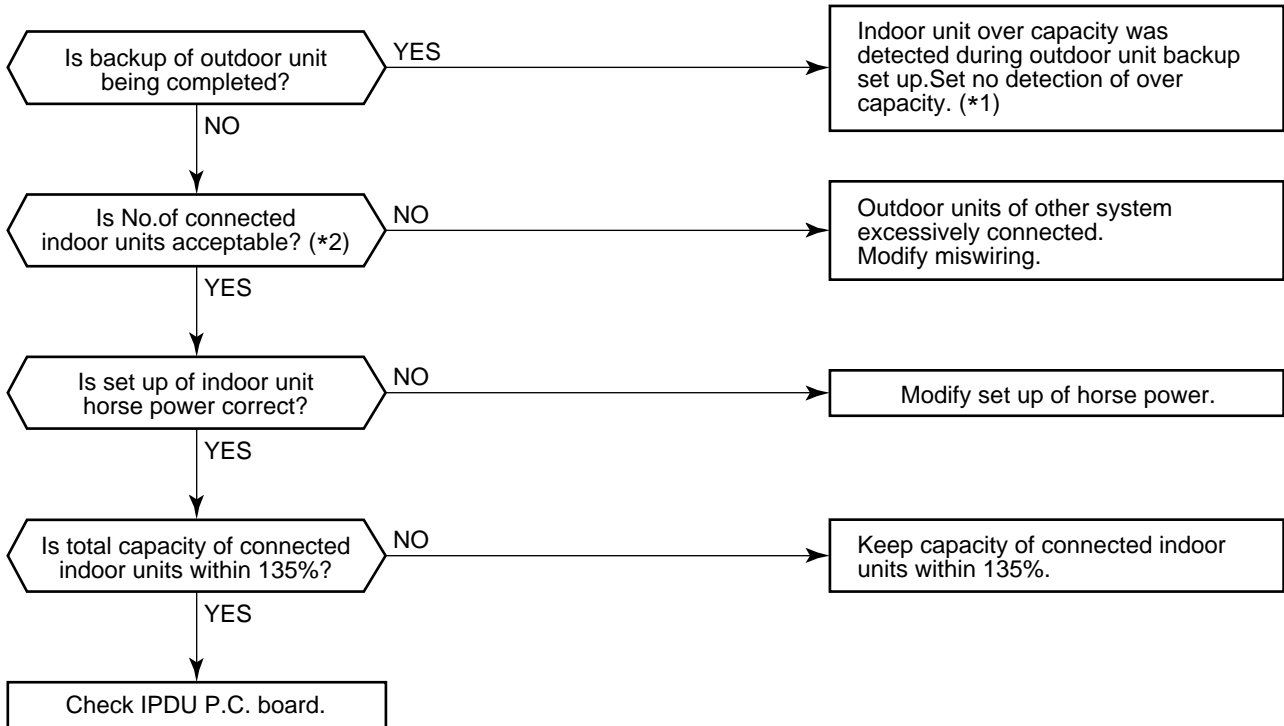

- (* 1) Set up no detection of over capacity
Turn on SW09 bit 2 on interface P.C. board of outdoor unit. (Usually OFF)
- (* 2) Check No. of connected indoor units.
Set SW01/SW02/SW03 on interface P.C. board of outdoor unit to 1/4/3, respectively.
No. of connected units is displayed on the 7 segment display.

Check code	Operation cause
[8C] Outdoor unit backup operation prohibited	Backup set up of outdoor unit

If there is a unit which is setting backup operation of the outdoor unit, heating operation cannot be performed. (*1)

- (* 1) Outdoor unit backup operation set up
When both SW06 Bit 1 and 2 on the interface P.C. board of the master outdoor unit are ON (Usually both are off.)

Check code	Operation cause
<p align="center">[8d] Reduction of No. of connected outdoor units</p>	<ol style="list-style-type: none"> 1. Outdoor unit backup set up 2. Outdoor unit power supply 3. Connection error of communication cable between outdoor units 4. Connection error of BUS communication 5. Interface P.C. board error

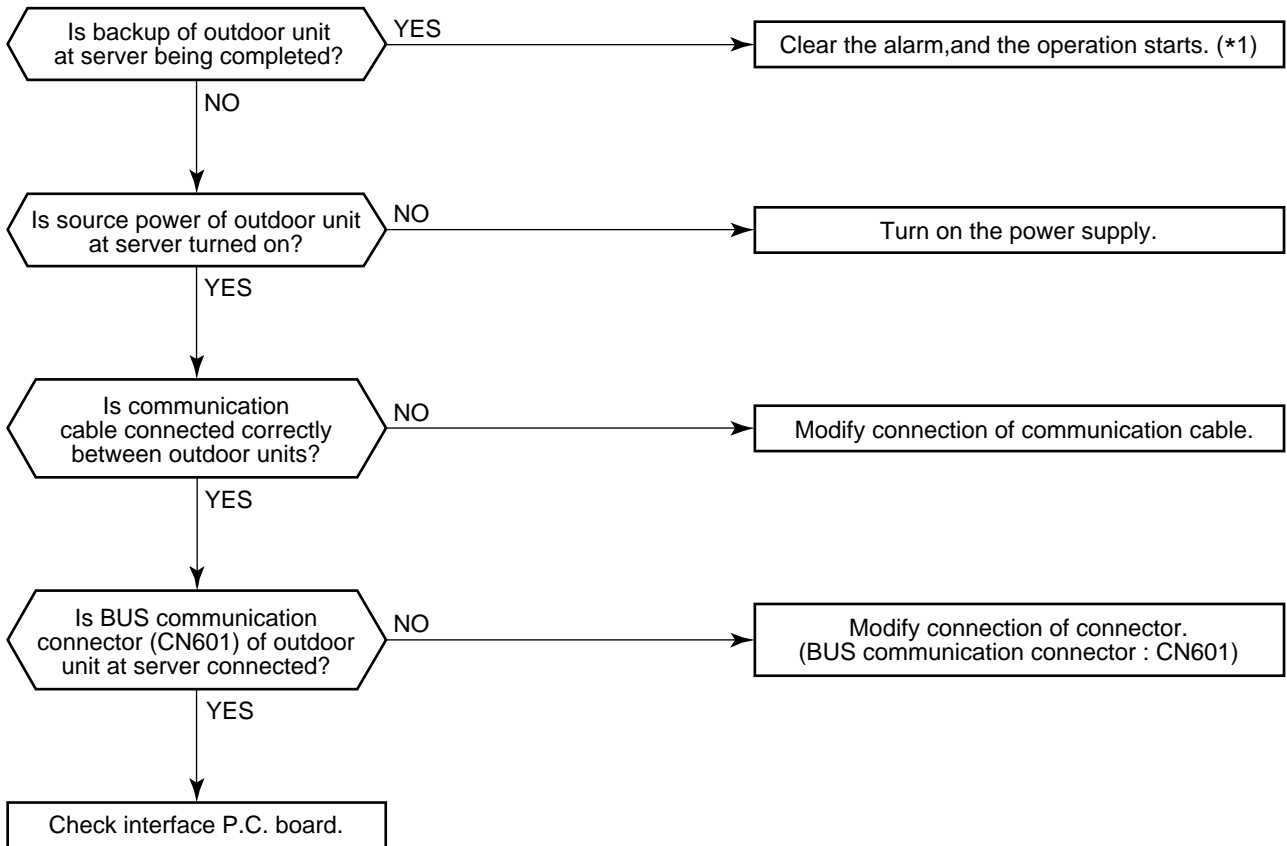

(* 1) How to clear the alarm

Set SW01/SW02/SW03 on interface P.C. board of the master outdoor unit to 2/16/1 respectively, and push SW04 for 5 seconds.

(Display on the 7 segment display : [Er.] [CL])

Check code	Operation cause
[8E] Outdoor unit connection over limit	1. No. of connected outdoor units over limit 2. Connection error of communication cable between outdoor units

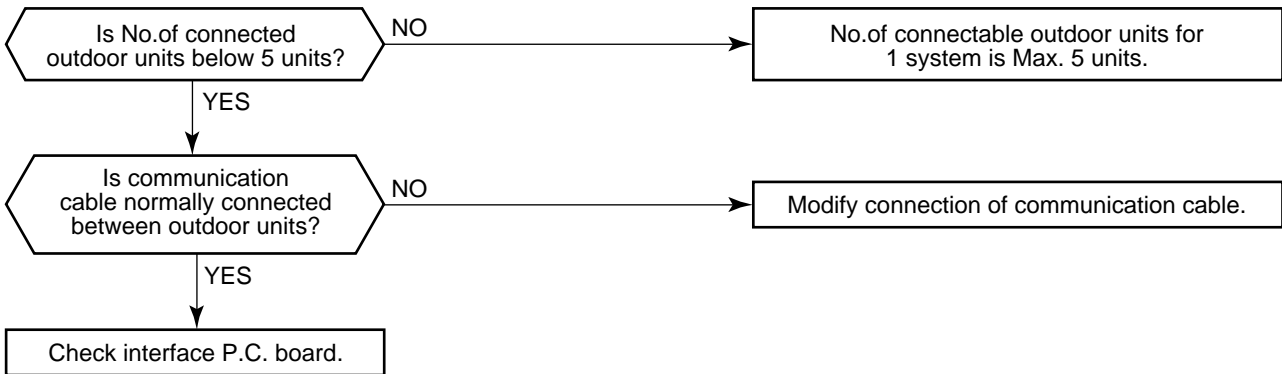

Check code	Operation cause
[8F] Duplicated terminal outdoor addresses	1. Address set up of outdoor unit was duplicated. 2. Interface P.C. board error

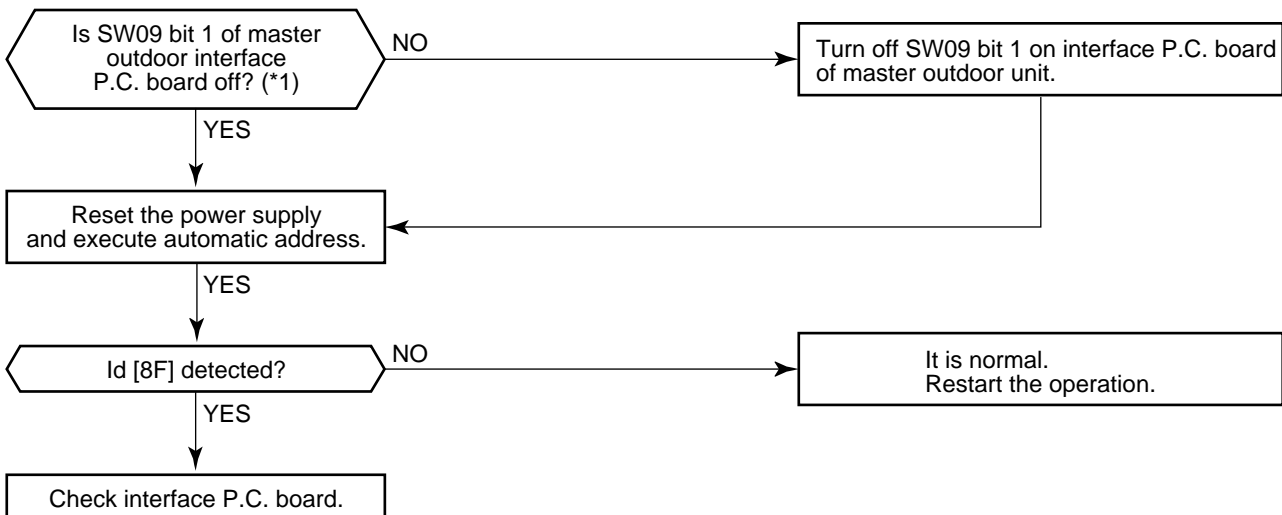

(* 1) SW09 bit 1 on interface P.C. board of the master outdoor unit at exchanges set up method of outdoor address.
Usually, the set up of outdoor address setting is automatic addressing (SW : OFF). If an incorrect set up is performed, the compressor may be damaged.

Check code	Operation cause
<p style="text-align: center;">[93] Indoor TC1 sensor alarm</p>	<p>TC1 sensor error</p>

Check connection of TC1 sensor (TC1 sensor : Indoor main P.C. board (MCC-1361) : CN20), disconnection of circuit, and characteristics of sensor resistance value. When the sensor is normal, replace indoor main P.C. board (MCC-1361)

<For 4-way Air Discharge Cassette type>

Check code	Operation cause
<p style="text-align: center;">[94] Indoor TC2 sensor alarm</p>	<p>TC2 sensor error</p>

Check connection of TC2 sensor (TC2 sensor : Indoor main P.C. board (MCC-1361) : CN05), disconnection of circuit, and characteristics of sensor resistance value. When the sensor is normal, replace indoor main P.C. board (MCC-1361)

Check code	Operation cause
<p style="text-align: center;">[95] Communication alarm between indoor and outdoor</p>	<ol style="list-style-type: none"> 1. Connection error of communication cable (PQ) between indoor and outdoor 2. Connection error of connector for indoor communication, P.C. board (MCC-1361) error 3. Connection error of connector for outdoor communication, interface P.C. board error

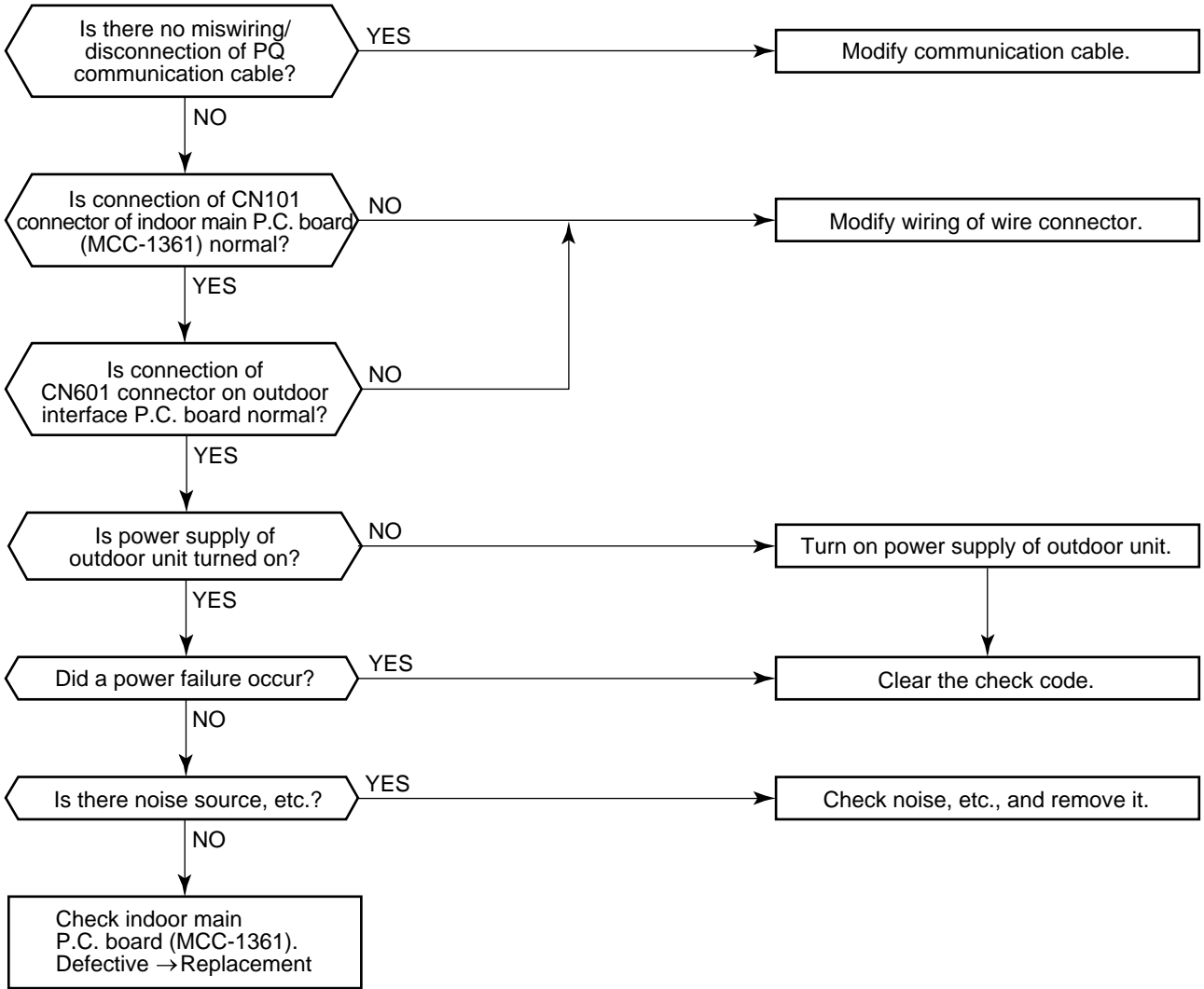

NOTE :

1. When turning on power supply of the indoor unit first of all, and pushing the START/STOP button before power supply of the outdoor unit is turned on, "95" may be displayed. This is not abnormal, and then clear the check code.
2. If "95" is displayed only on the 7 segment of the outdoor unit, it is considered that power supply of the master outdoor unit is not switched on, or P.C. board error of the master outdoor unit occurs.

Check code	Operation cause
<p align="center">[96] Consistency detection of indoor and outdoor addresses</p>	<ol style="list-style-type: none"> 1. Connection error of communication cable (PQ) between indoor and outdoor 2. Abnormal No. of connected indoor units 3. Wiring connection error of central management remote controller

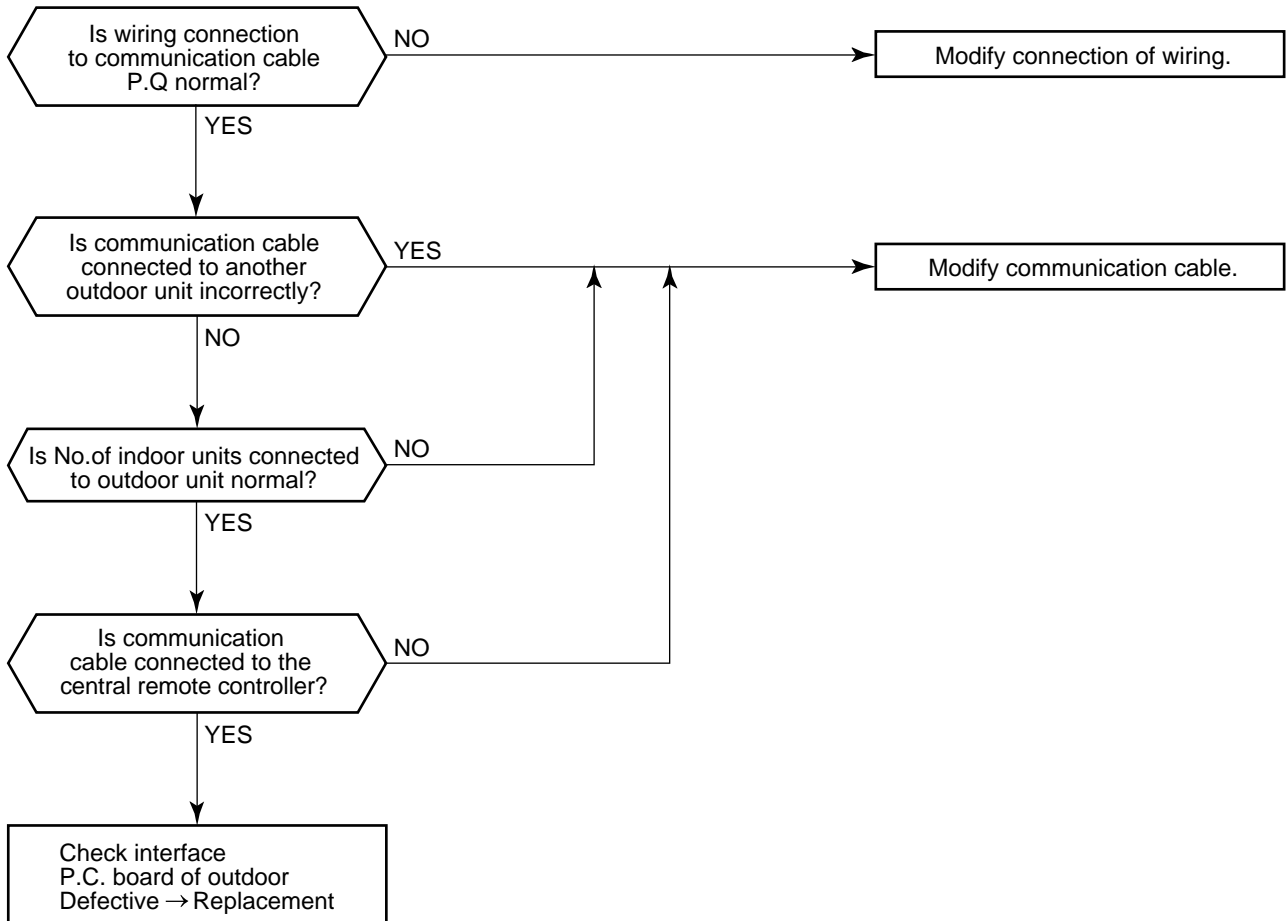

<For 4-way Air Discharge Cassette type>

Check code	Operation cause
<p style="text-align: center;">[97] BUS communication alarm (1)</p>	<ol style="list-style-type: none"> 1. Connection error of communication cable (PQ) between indoor and outdoor 2. Connection error of (XY) for outdoor or indoor communication 3. Power supply system error of the central controller and indoor 4. Noise of peripheral devices 5. Power failure 6. Failure of indoor main P.C. board (MCC-1361) or central controller

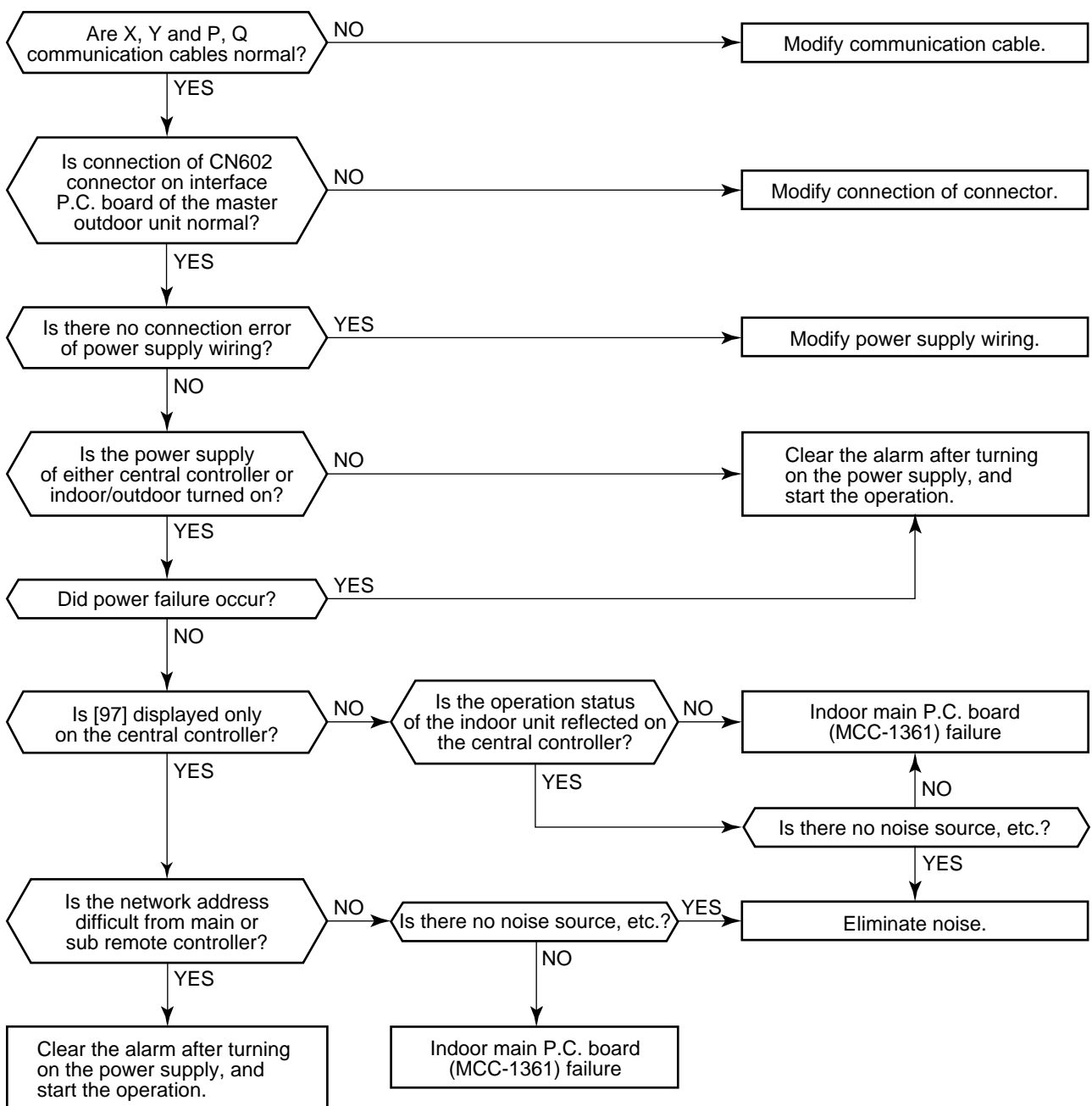

<For 4-way Air Discharge Cassette type>

Check code	Operation cause
<p align="center">[98] BUS communication alarm (2)</p>	<p>1. Miswiring of XY communication cables 2. Duplicated network addresses 3. Failure on indoor main P.C. board (MCC-1361), central controller</p>

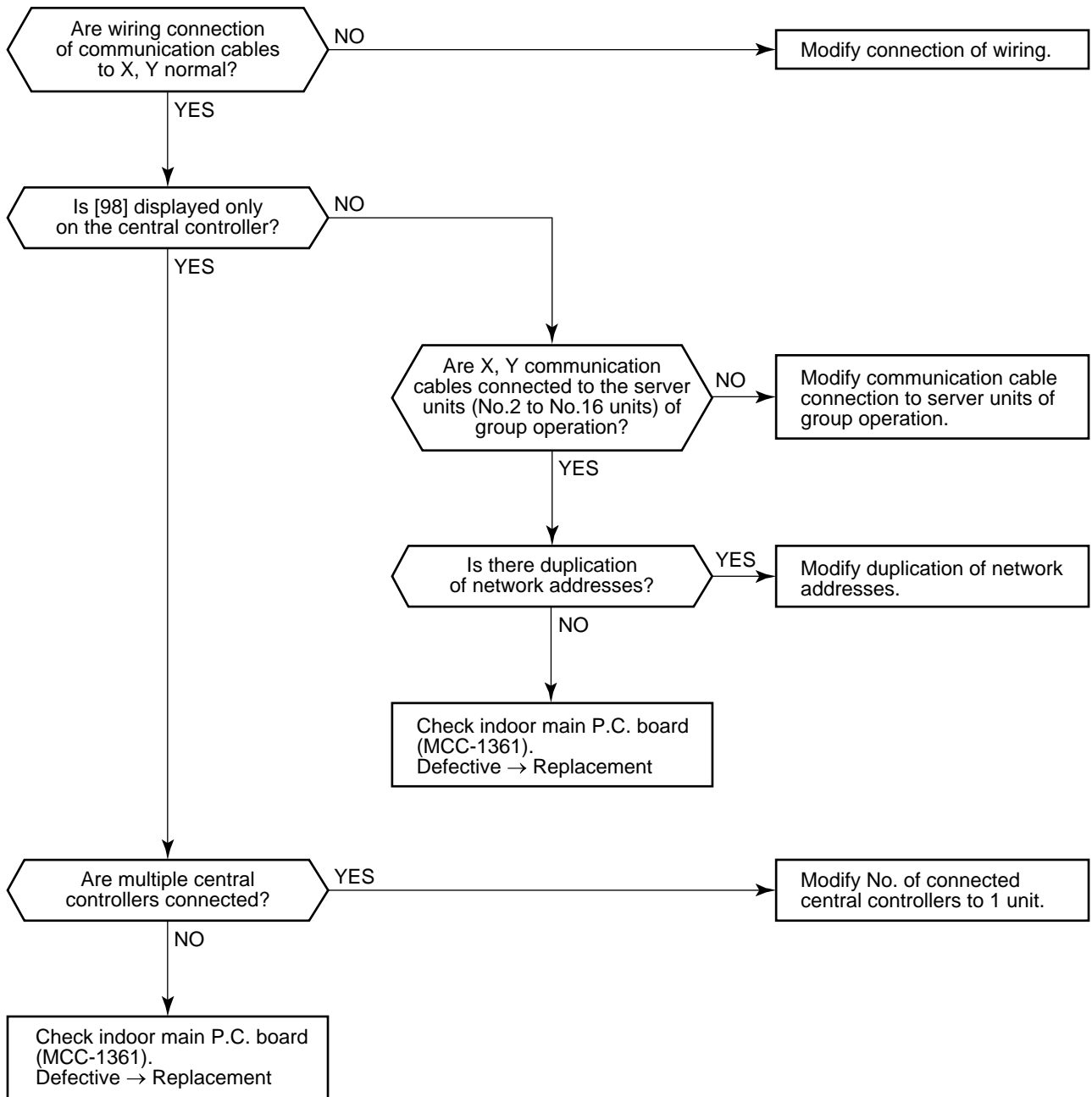

<For 4-way Air Discharge Cassette type>

Check code	Operation cause
<p align="center">[99] Indoor remote controller communication alarm</p>	<ol style="list-style-type: none"> 1. Remote controller circuit connection error 2. Duplicated indoor No.1 units 3. Remote controller error 4. Indoor main P.C. board (MCC-1361) failure

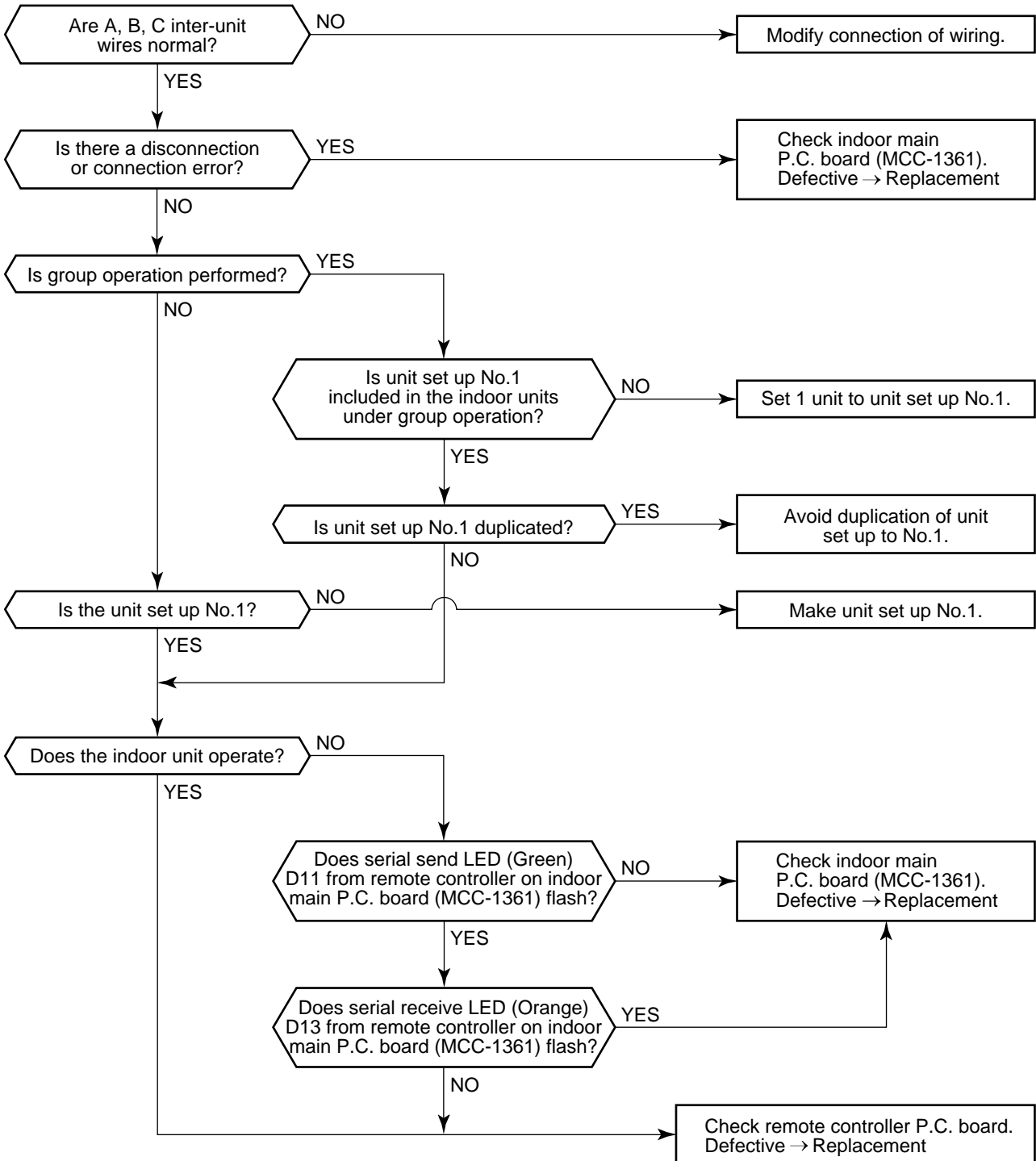

Check code	Operation cause
[9A] Miswiring/Misconnection of indoor	1. Miswiring/Mispiping of indoor/outdoor units 2. Insufficient refrigerant 3. Blockage in pipe run

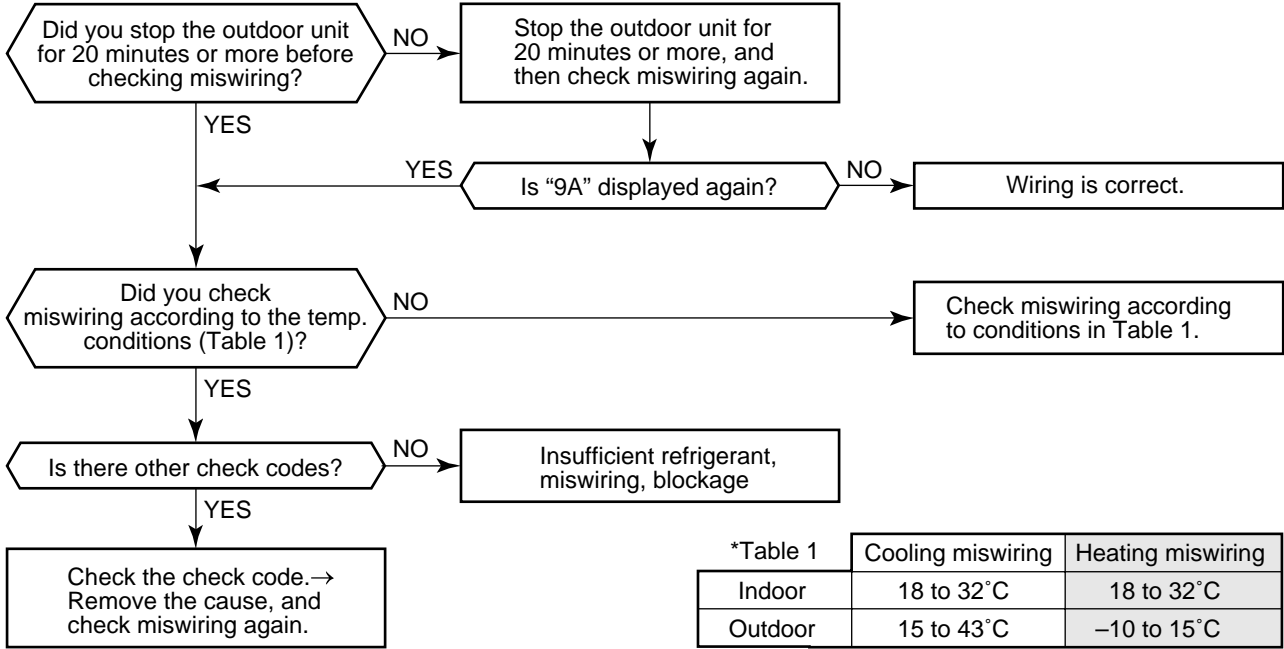

*Table 1	Cooling miswiring	Heating miswiring
Indoor	18 to 32°C	18 to 32°C
Outdoor	15 to 43°C	-10 to 15°C

Check code	Operation cause
[9F] Indoor PMV blockage	1. Indoor unit PMV connection error/main unit error 2. TC1 sensor/TC2 sensor/TA sensor error 3. Miswiring/Mispiping between indoor and outdoor 4. Blockage in pipe

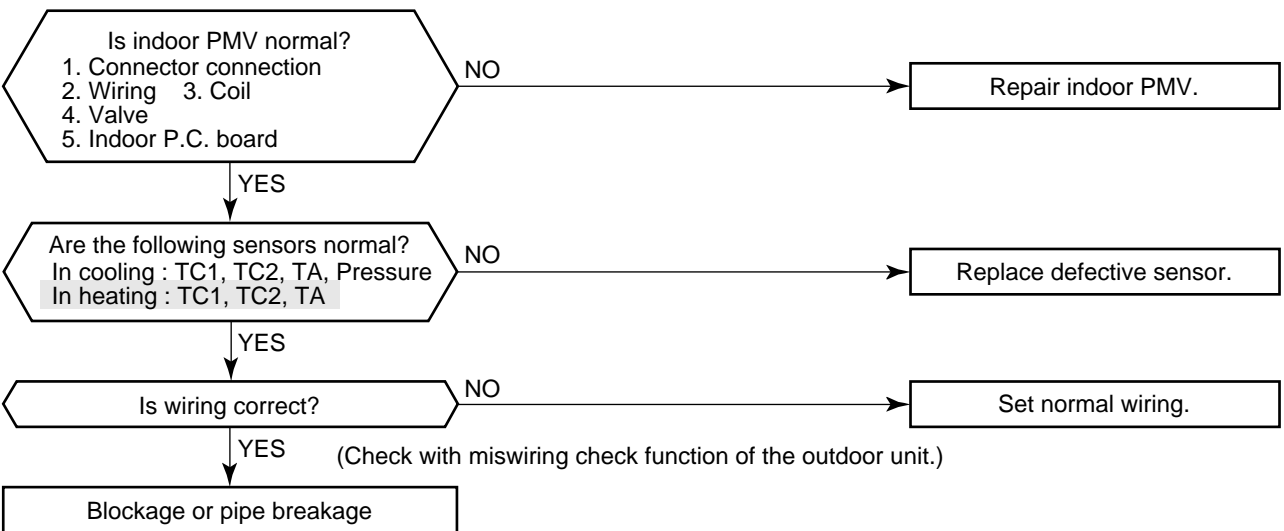

Check code	Operation cause
[A0] TD1 sensor alarm	TD1 sensor open/short

Open/short of TD1 sensor was detected. Check disconnection of connector (TD1 sensor : CN502) and characteristics of sensor resistance value.

When sensor is normal, replace interface P.C. board of the outdoor unit.

Check code	Operation cause
[A1] TD2 sensor alarm	TD2 sensor open/short

Open/short of TD2 sensor was detected. Check disconnection of connector (TD2 sensor : CN503) and characteristics of sensor resistance value.

When sensor is normal, replace interface P.C. board of the outdoor unit.

Check code	Operation cause
[A2] TS1 sensor alarm	TS1 sensor open/short

Open/short of TS1 sensor was detected. Check disconnection of connector (TS1 sensor : CN504) and characteristics of sensor resistance value.

When sensor is normal, replace interface P.C. board of the outdoor unit.

Check code	Operation cause
<p style="text-align: center;">[A6] Discharge temperature TD1 alarm</p>	<ol style="list-style-type: none"> 1. Outdoor unit service valve closed 2. Blockage of check valve to interrupt the liquid line. 3. Outdoor PMV A error or cooling bypass PMV B error 4. TD sensor error 5. Insufficient refrigerant, blockage in pipe

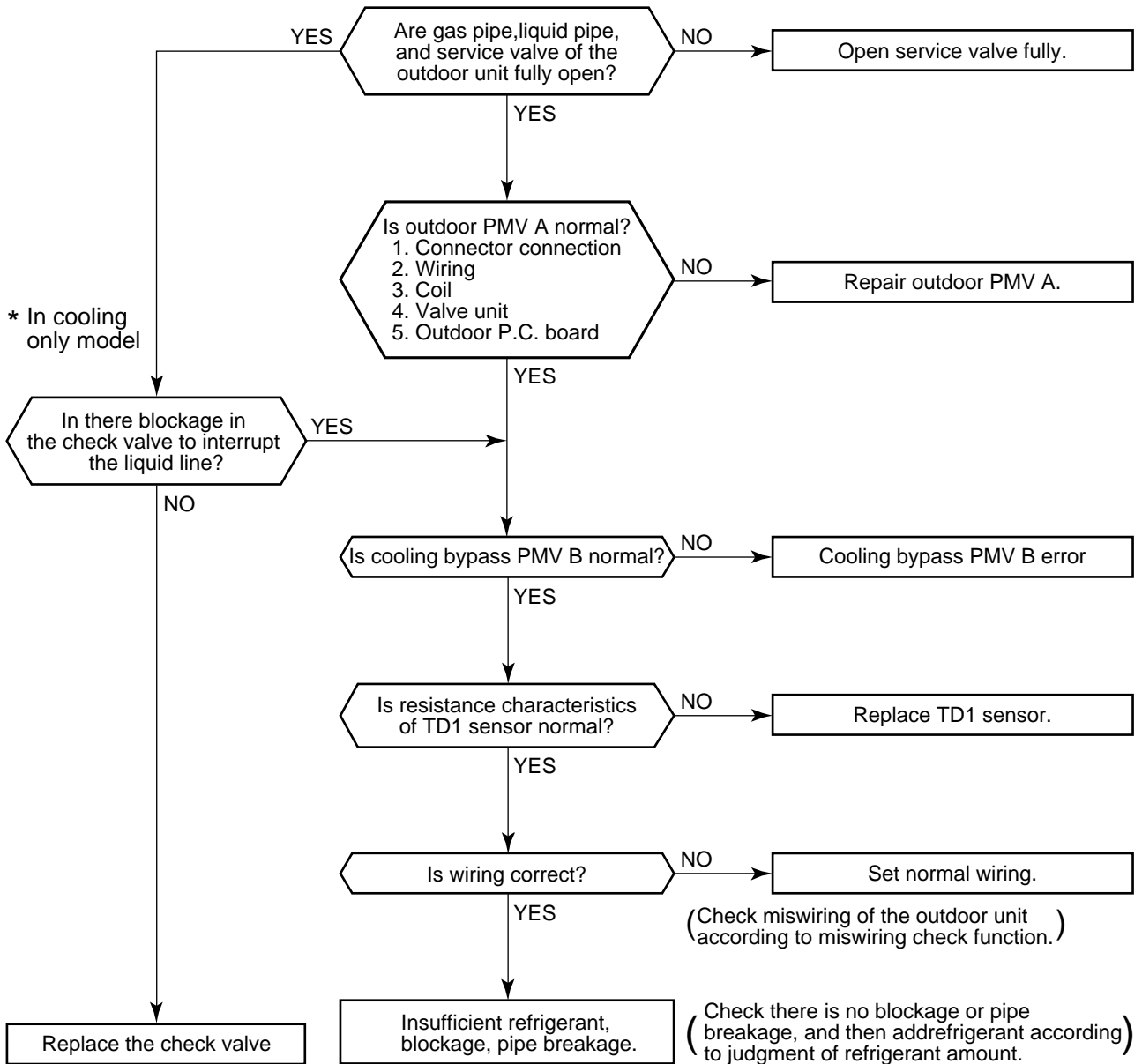

Check code	Operation cause
[A7] TS condition gas leak detection	1. Outdoor unit service valve closed 2. Blockage of check valve to interrupt the liquid line. 3. Outdoor PMV A error 4. TS sensor error 5. Insufficient refrigerant, blockage in pipe 6. 4-way valve error

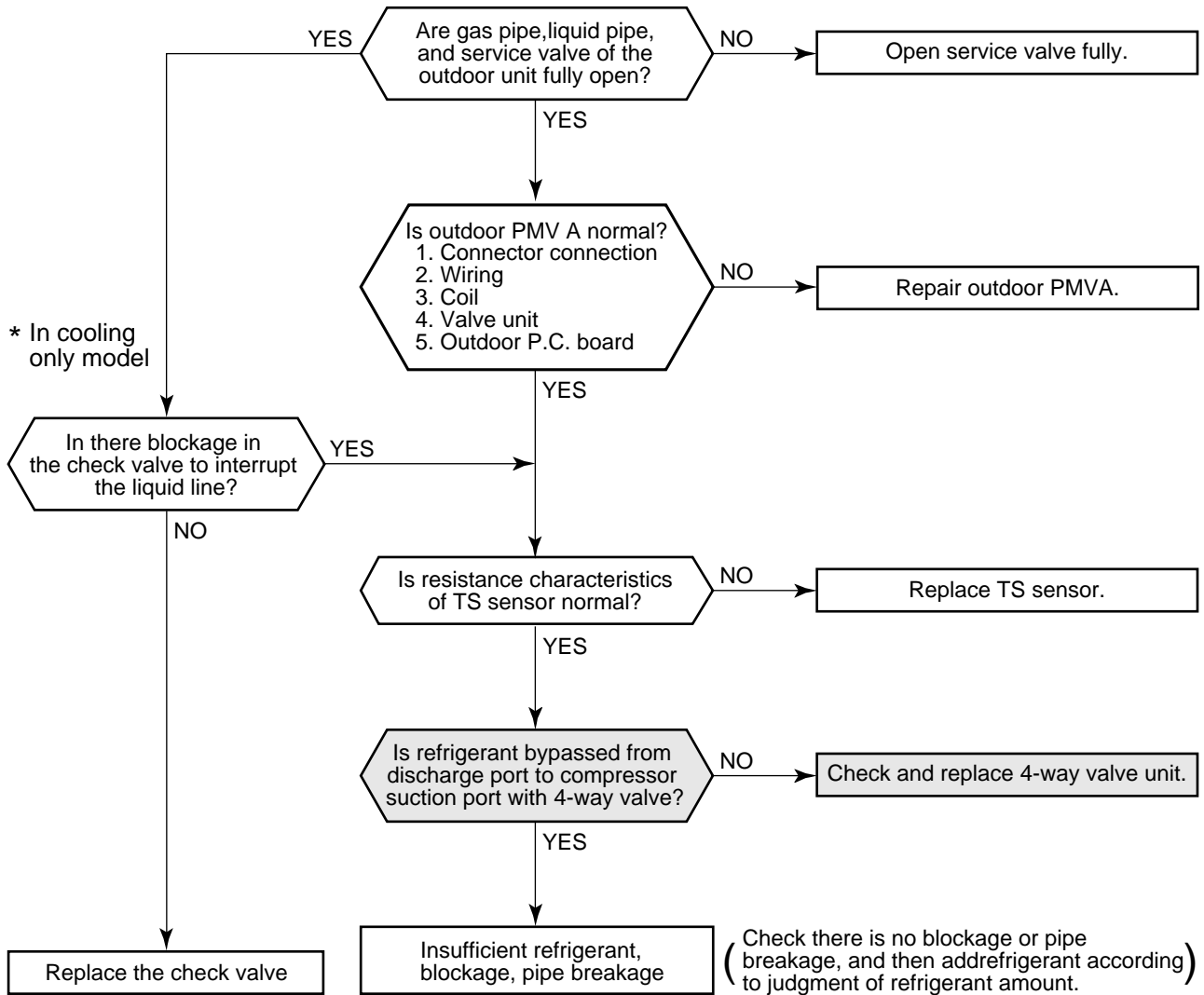

Check code	Operation cause
[AA] Pd sensor alarm	Pd sensor output voltage alarm

It is abnormal output voltage of Pd sensor. Check disconnection of connector connection circuit (Pd sensor : CN501) and output voltage of the sensor.
 If the sensor is normal, replace the outdoor interface P.C. board.

Check code	Operation cause
[Ab] Pressure sensor misconnection	1. Connector misconnection of Pd/Ps sensors 2. Pd/Ps sensor error 3. Compressor inverse operation, compressing error

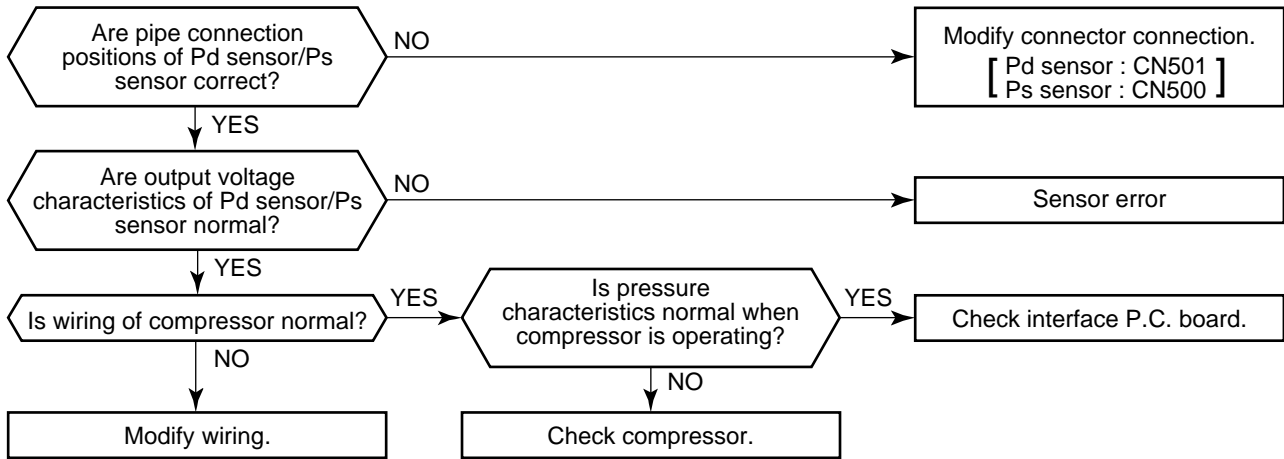

Check code	Operation cause
[AE] TD1 condition gas leak detection	1. Outdoor unit service valve closed 2. Blockage of check valve to interrupt the liquid line. 3. Outdoor PMV A error or cooling bypass PMV B error 4. TD1 sensor error 5. Insufficient refrigerant, blockage in pipe 6. Blockage of indoor filter.

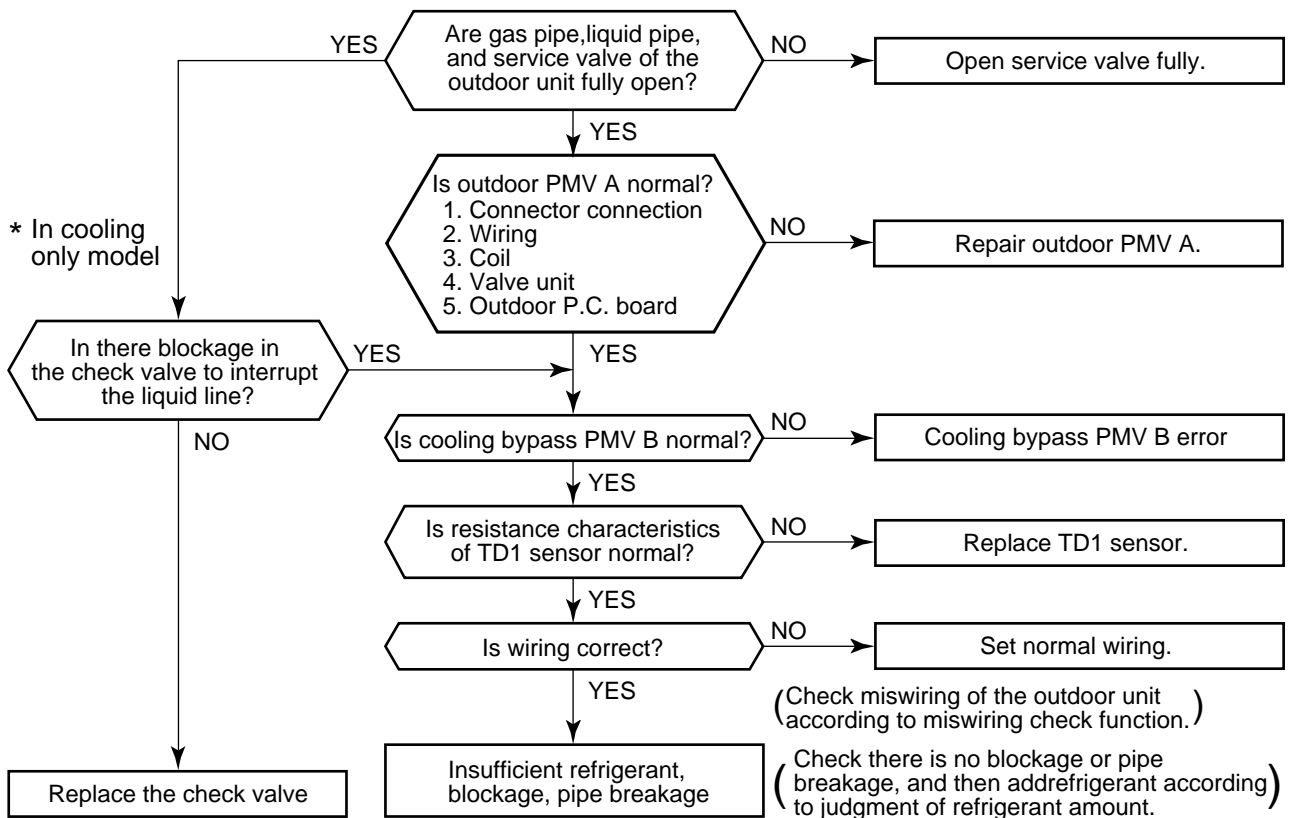

Check code	Operation cause
[AF] Phase order alarm	Abnormal power phase order or missing a phase of power supply of outdoor unit

There is an abnormal power phase order or missing a phase of power supply of the outdoor unit.
Modify power supply wiring

Check code	Operation cause
[b4] Ps sensor alarm	<ol style="list-style-type: none"> 1. Ps sensor error 2. Ps sensor connection error 3. Compressor compressing error 4. 4-way valve error

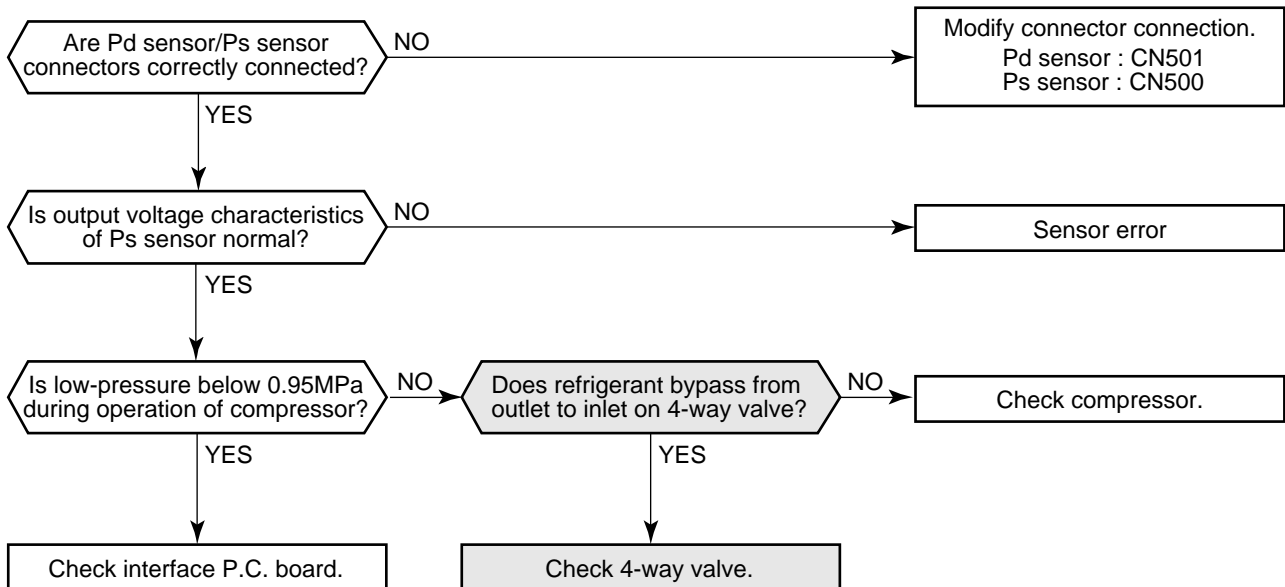

Check code	Operation cause
[b5] Indoor outside input alarm [b6] Indoor outside interlock	1. External device error 2. Indoor main P.C. board (MCC-1361) error

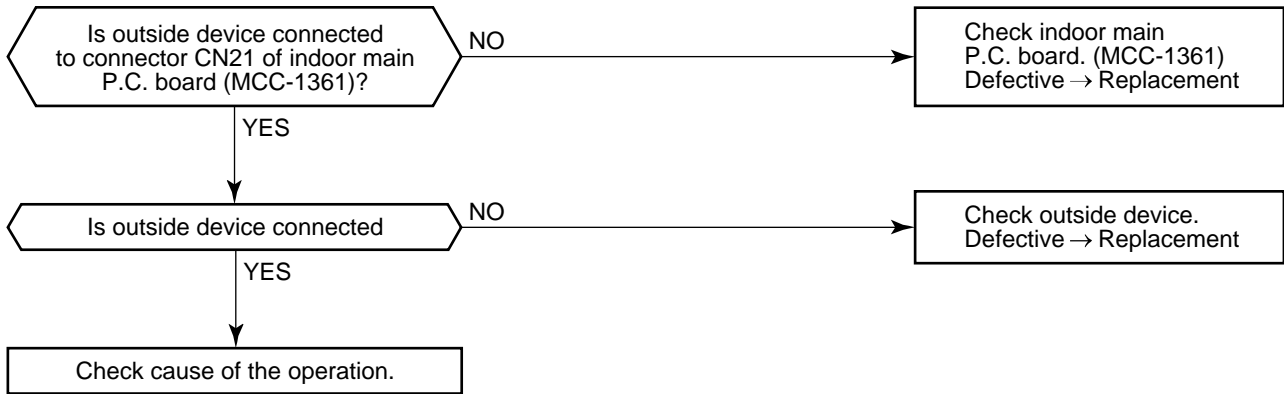

Check code	Operation cause
[b7] Secondly unit alarm in group operating	Secondly unit error at group operating of the indoor unit

When a trouble occurred on any one of the secondly units operating in a group, an alarm is output to the central control remote controller.
 Using the remote controller of indoor unit, check a trouble on each secondly unit and take measures against the error code.

Check code	Operation cause
[b9] Indoor pressure sensor alarm	Output voltage error of indoor pressure sensor

There is an abnormal output voltage of indoor pressure sensor. Check disconnection of connector (CN23) of indoor main P.C. board (MCC-1361) and output voltage of the sensor.
 If the sensor is normal, replace the indoor main P.C. board. (MCC-1361)

Check code	Operation cause
[bb] Discharge temperature TD2 alarm	1. Outdoor unit service valve closed 2. Blockage of check valve to interrupt the liquid line. 3. Outdoor PMV A error or cooling bypass PMV B error 4. TD sensor error 5. Insufficient refrigerant, blockage in pipe

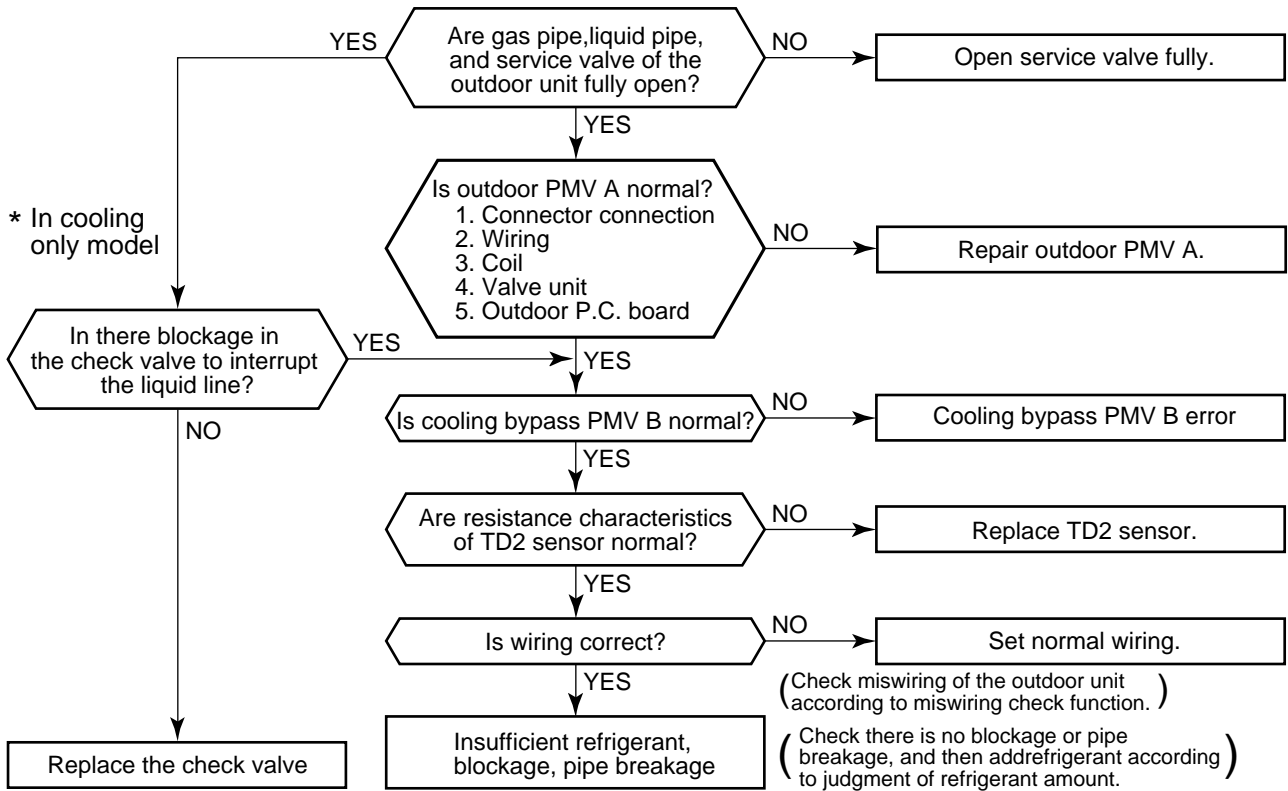

Check code	Operation cause
[bd] Mg-SW protective operation	1. Mg-SW contact deposit protective operation 2. TD sensor error 3. Pd sensor/Ps sensor error 4. Insufficient refrigerant, blockage in pipe

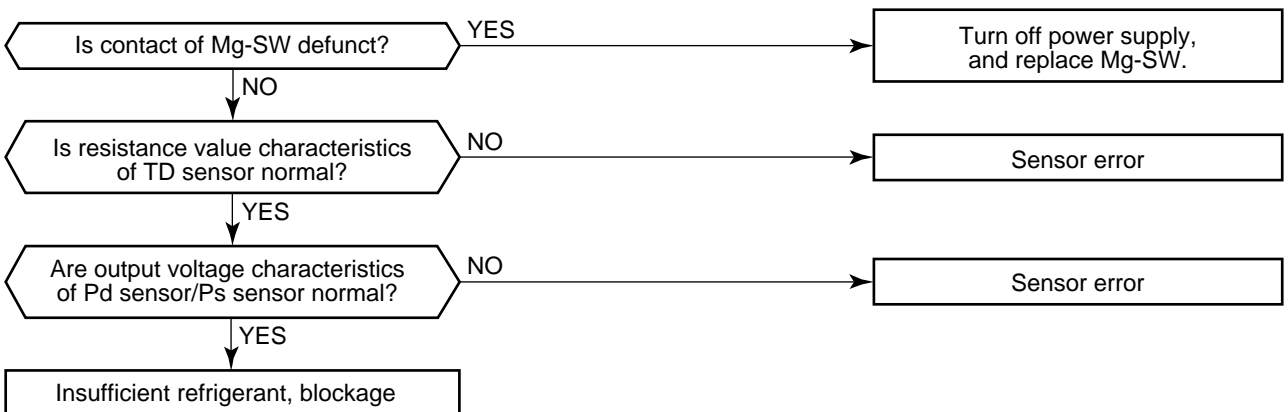

Check code	Operation cause
<p style="text-align: center;">[bE] Low-pressure protective operation</p>	<ol style="list-style-type: none"> 1. Ps sensor error 2. Service valve closed 3. Indoor fan capacitor error 4. Indoor/outdoor PMV blockage 5. Indoor heat exchanger blockage 6. SV2 circuit 7. Incorrect wiring of communication cable between indoor and outdoor units

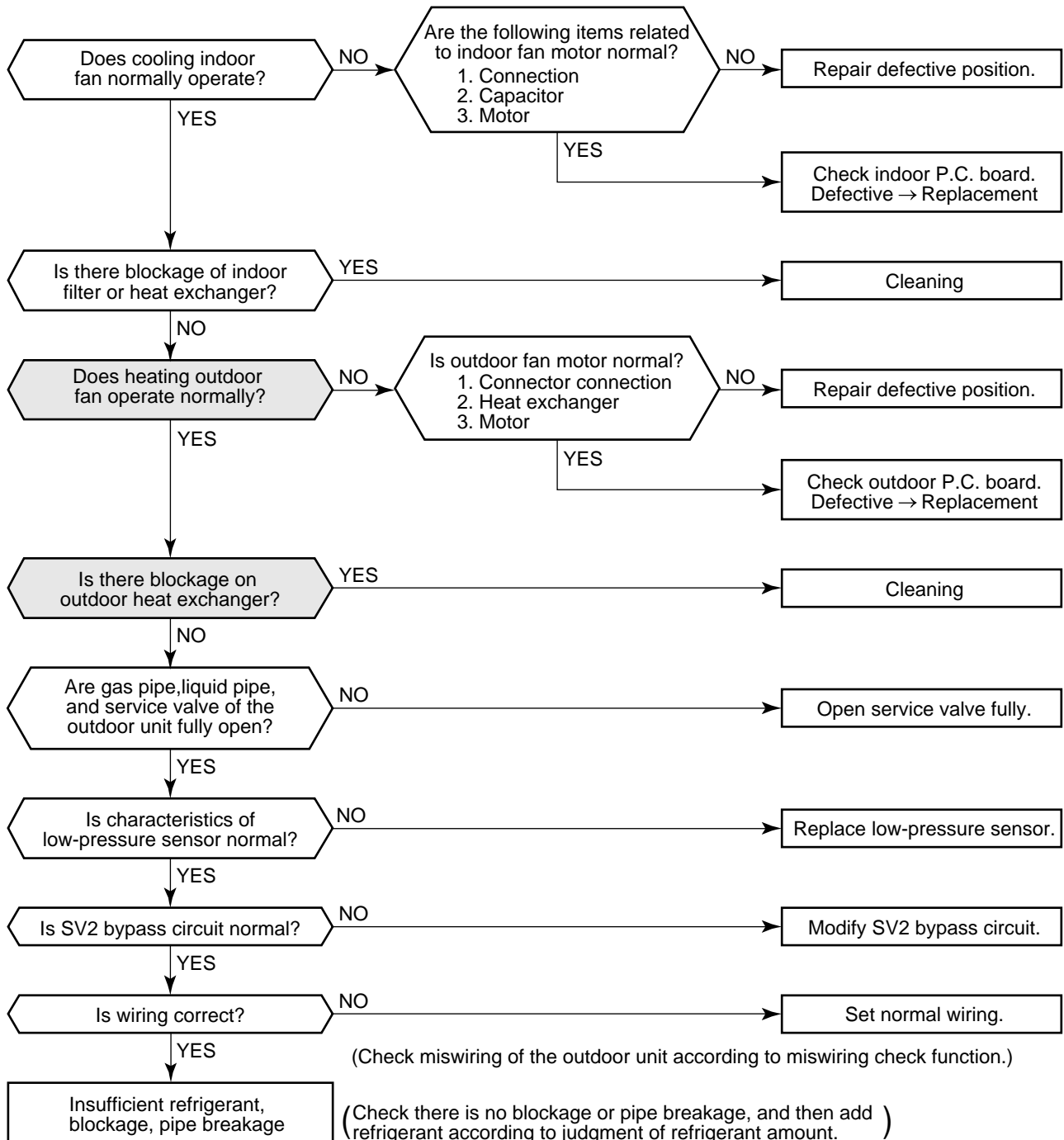

Check code	Operation cause
[cF] Communication alarm between indoor MCU	1. Error of connection between CN28 of indoor main P.C. board (MCC-1361) and CN27 of indoor motor P.C. board (MCC-1382) 2. Indoor main P.C. board (MCC-1361) error 3. Indoor motor P.C. board (MCC-1382) error

Check disconnection of lead wire and connection of connector between indoor main P.C. board (MCC-1361) and indoor motor P.C. board (MCC-1382).
 If no error is detected, replace indoor main P.C. board (MCC-1361) or indoor motor P.C. board (MCC-1382).

Check code	Operation cause
[d1] Master outdoor unit set up alarm	1. No. of connected inverter outdoor units 2. Incorrect set up of master outdoor unit 3. Defective outdoor interface P.C. board

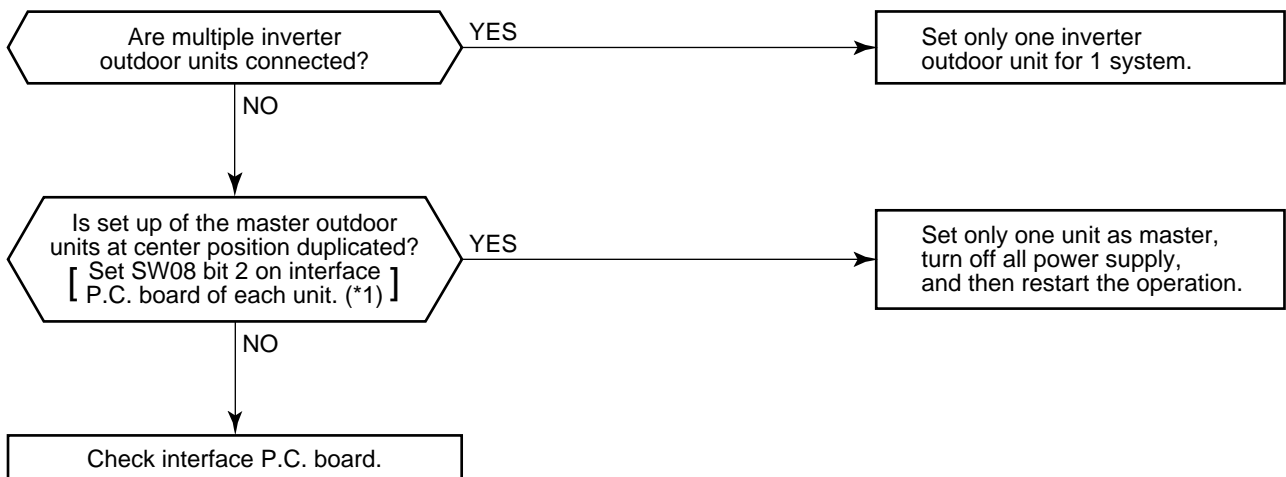

(* 1) Set up of outdoor unit at center position (SW08 bit 2 set up on outdoor interface P.C. board)
 OFF : Server/ON : Master (Automatic set up for inverter outdoor unit)

Check code	Operation cause
[d2] Server outdoor alarm	Defective server outdoor unit

An error occurs in the server outdoor unit. Confirm the check code of the server unit, and check it according to the diagnostic procedure for each check code.

Check code	Operation cause
[d3] TH sensor alarm	Error of temp. sensor incorporated in IGBT

There is an error with the temp. sensor incorporated in IGBT. Check connection of connectors CN07 on IPDU P.C. board and CN600 on interface P.C. board. If there is no problem, replace IPDU P.C. board.

Check code	Operation cause
[d4] TK1 sensor alarm	TK1 sensor open/short

Open/short of TK1 was detected. Check connection (TK1 sensor : CN516), disconnection of circuit, and resistance value characteristics of the sensor.
If sensor is normal, replace the outdoor interface P.C. board.

Check code	Operation cause
[d5] TK2 sensor alarm	TK2 sensor open/short

Open/short of TK2 was detected. Check connector (TK2 sensor : CN515), disconnection of circuit, and resistance value characteristics of the sensor.
If sensor is normal, replace the outdoor interface P.C. board.

Check code	Operation cause
[d6] TK3 sensor alarm	TK3 sensor open/short

Open/short of TK3 was detected. Check connection (TK3 sensor : CN507), disconnection of circuit, and resistance value characteristics of the sensor.
If sensor is normal, replace the outdoor interface P.C. board.

Check code	Operation cause
<p style="text-align: center;">[d7] Protection of low oil level detection</p>	<ol style="list-style-type: none"> 1. Balancing pipe valve (All outdoor units in the identical line) closed 2. Compressor case oil removal valve closed 3. Miswiring of TK1 sensor/TK2 sensor 4. Refrigerant stagnation in compressor case 5. SVA3, SV3B, SV3C valves error 6. Blockage in oil return circuit of oil separator 7. Blockage in oil tank circuit

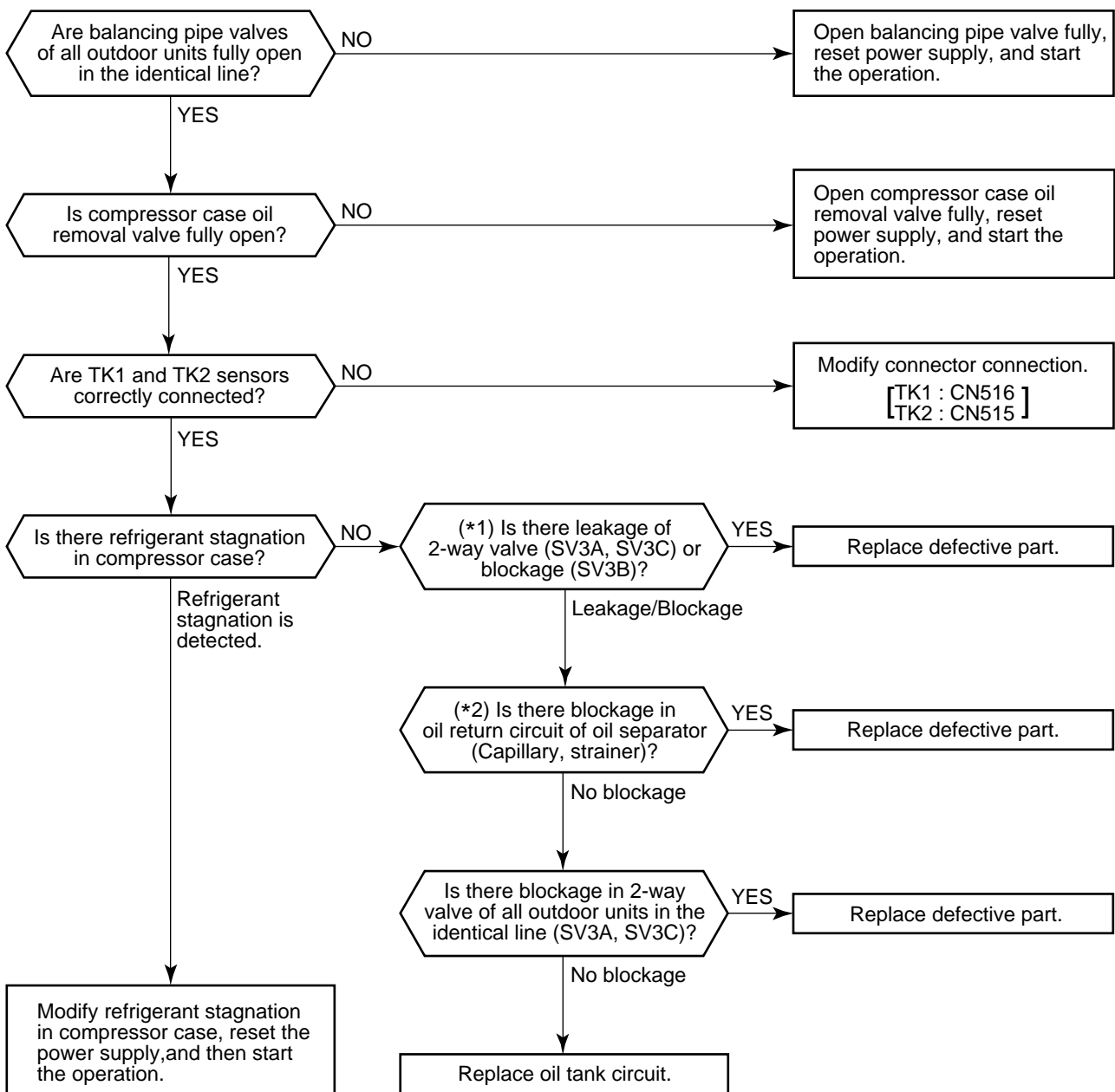

(* 1) 2-way valve leakage/blockage check procedure

1. After resetting power supply, start a trial operation.
2. Set SW01/SW02/SW03 on interface P.C. board to 1/16/1, respectively.
3. Check display on 7 segment of interface P.C. board.

	7 segment display
When operation has started	"OL" "--"
During detection of oil level	"OL" "FF" or "Numeral"
Judgment result of oil level	"OL" "A0" or "A1"

In case of judgment result "A0" → Oil level is adequate. Resume the operation.

In case of judgment result "A1" → Oil level is insufficient. Check the following items.

3. Remove SV3C valve connector, reset the power supply, and start a trial operation.

4. After operation for several minutes, check temperature at secondary side of SV3C valve (A in the right figure).

→ When temperature is high (Equivalent to discharge temp.), leakage occurs from SV3C valve.

Replace SV3C valve.

5. Remove SV3A valve connector, and start a trial operation under condition that AC220V–240V-power is on to SV3C valve.

6. After operation for several minutes, check temperature at secondary side of SV3A valve (B in the right figure).

→ When temperature is high (Equivalent to discharge temp.), leakage occurs from SV3A valve.

Replace SV3A valve.

7. Using charge hose, etc., connect the check joint of gas pipe and the charge port of balancing pipe.

8. Start a trial operation under condition that AC220–240V, 50Hz (**AC220V, 60Hz**) power is on to SV3B valve.

9. After operation for several minutes, check temperature at secondary side of SV3B valve (C in the right figure).

→ When temperature is low (Equivalent to suction temp.), blockage occurs in SV3B valve or strainer.

Replace blockage part.

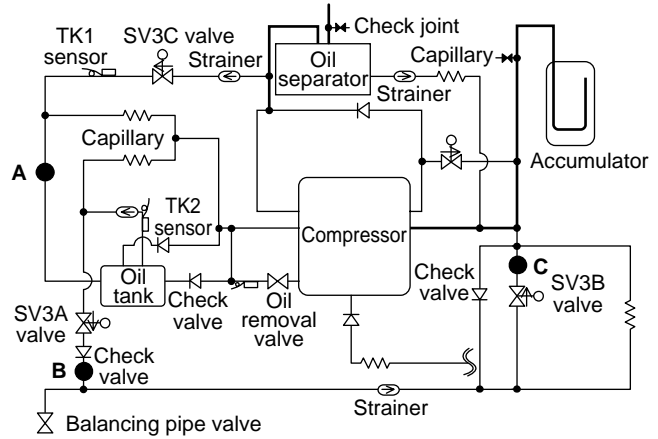

(* 2) Blockage check procedure for oil return circuit of oil separator

1. Check temperature of oil circuit during operation of outdoor unit.

→ If temperature is low, clogging occurs in capillary or strainer. **Replace blocked part.**

Check code	Operation cause
[d8] TK1 temperature detection circuit alarm	TK1 sensor out of place, miswiring, resistance value characteristics error

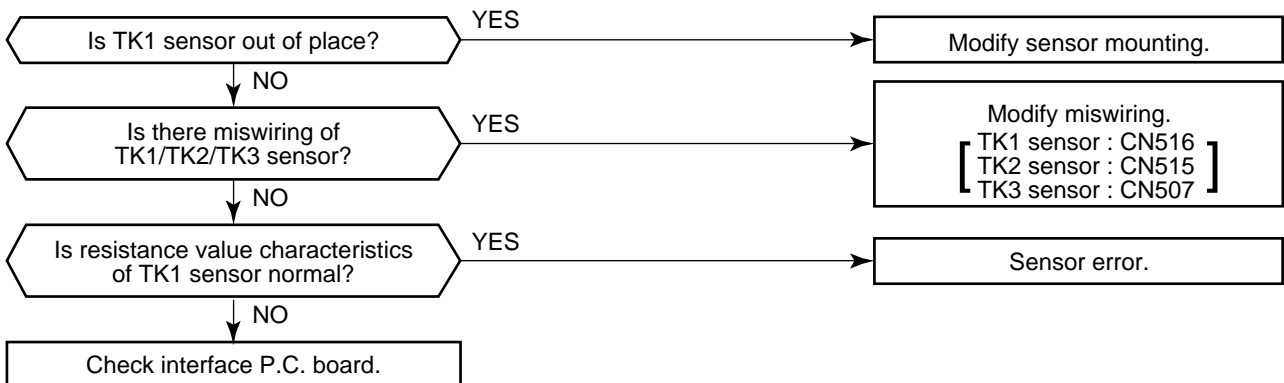

Check code	Operation cause
[d9] TK2 temperature detection circuit alarm	1. TK2 sensor out of place, miswiring, resistance value characteristics error 2. Oil tank peripheral circuit error [Check valve leakage Capillary blockage Strainer blockage]

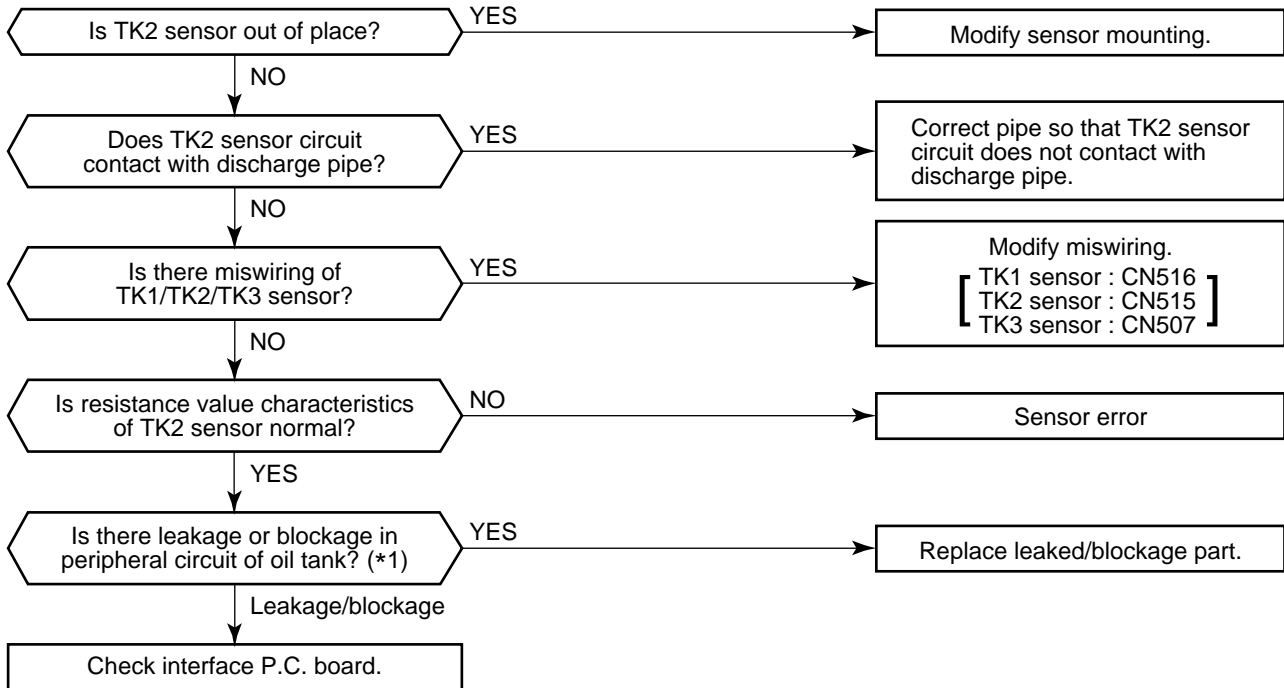

(* 1) Oil tank peripheral circuit leakage/blockage check procedure

- After resetting power supply, start a trial operation.
- Set SW01/SW02/SW03 on interface P.C. board to 1/16/1, respectively.
- Check display on the 7 segment of interface P.C. board.

	7 segment display
When operation has started	"OL" "--"
During detection of oil level	"OL" "FF" or "Numeral"
Judgment result of oil level	"OL" "A0" "A1" or "A4"

In case of judgment result "A0" "A1" → Oil level is adequate. Resume the operation.

In case of judgment result "A4" → Possibility of oil tank circuit leakage/blockage is considered

Check the following items.

- Start a trial operation under condition that AC220–240V, 50Hz (**AC220V, 60Hz**) power is on to SV3C valve.
- During operation, check whether discharge gas flows to the strainer secondary side (A part in the right figure) at downstream of TK2 sensor circuit, and capillary secondary side (B part in the right figure).
→ **If blocked part is found, replace the part.**
- During operation, check whether leakage occurs in the check valve (Two positions) of pipe connecting the oil tank and compressor case. (Check temperature of C part in the right figure.)
→ **If leakage is found, replace the part.**

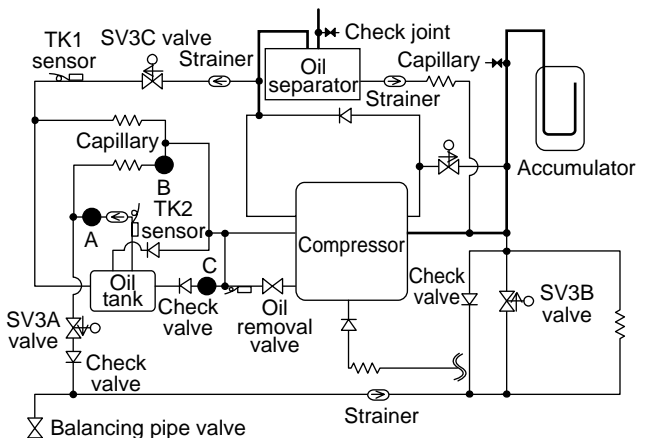

Check code	Operation cause
<p style="text-align: center;">[dA] Abnormal overheat of heat sink</p>	<ol style="list-style-type: none"> 1. Power supply failure 2. Outdoor fan error 3. Heat sink installation failure 4. Blockage of heat sink cooling duct 5. Defective IPDU P.C. board

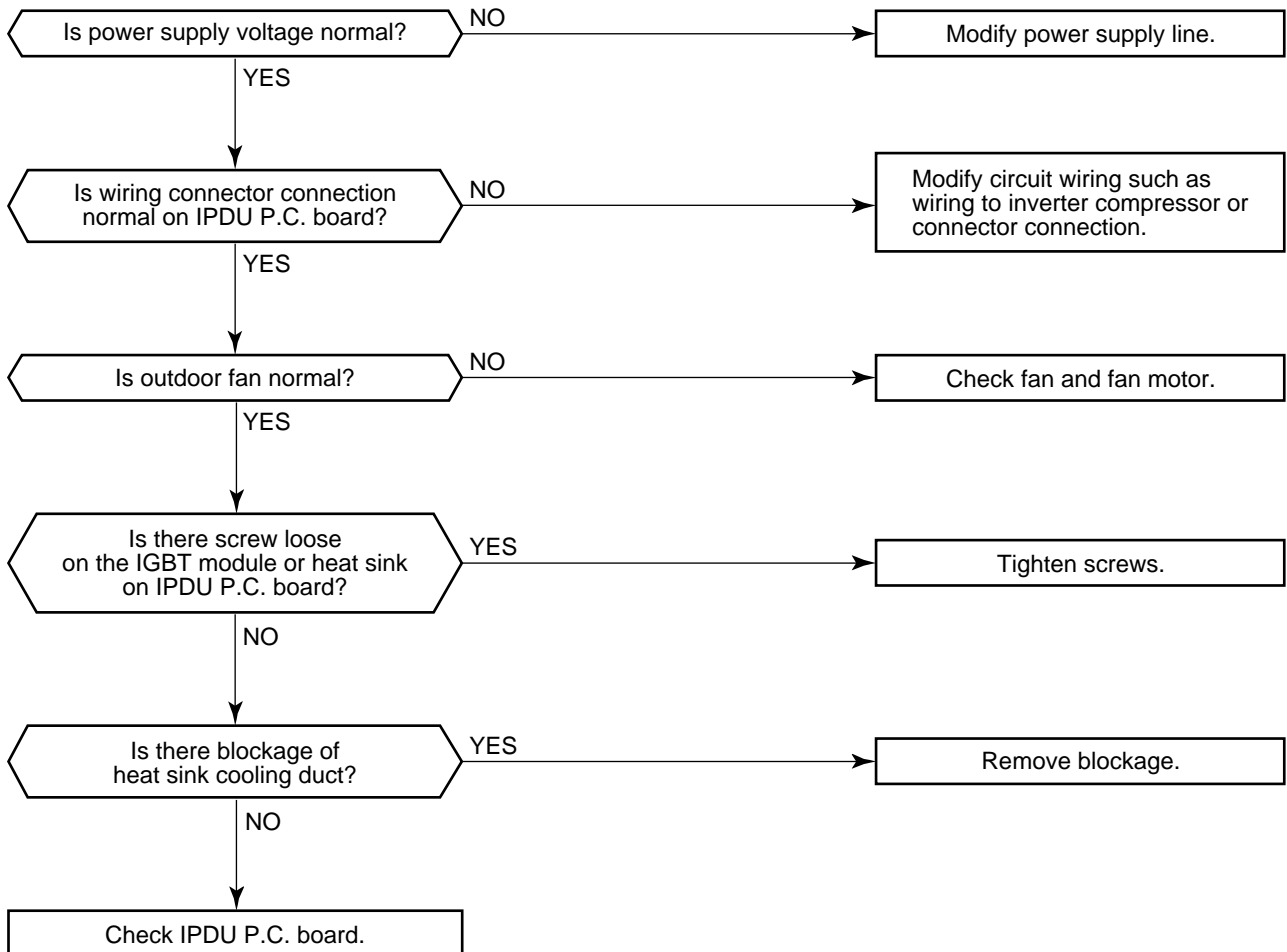

Check code	Operation cause
[db] Oil level detection circuit blockage detection	1. Blockage in SV3C valve 2. Blockage in SV3C valve circuit

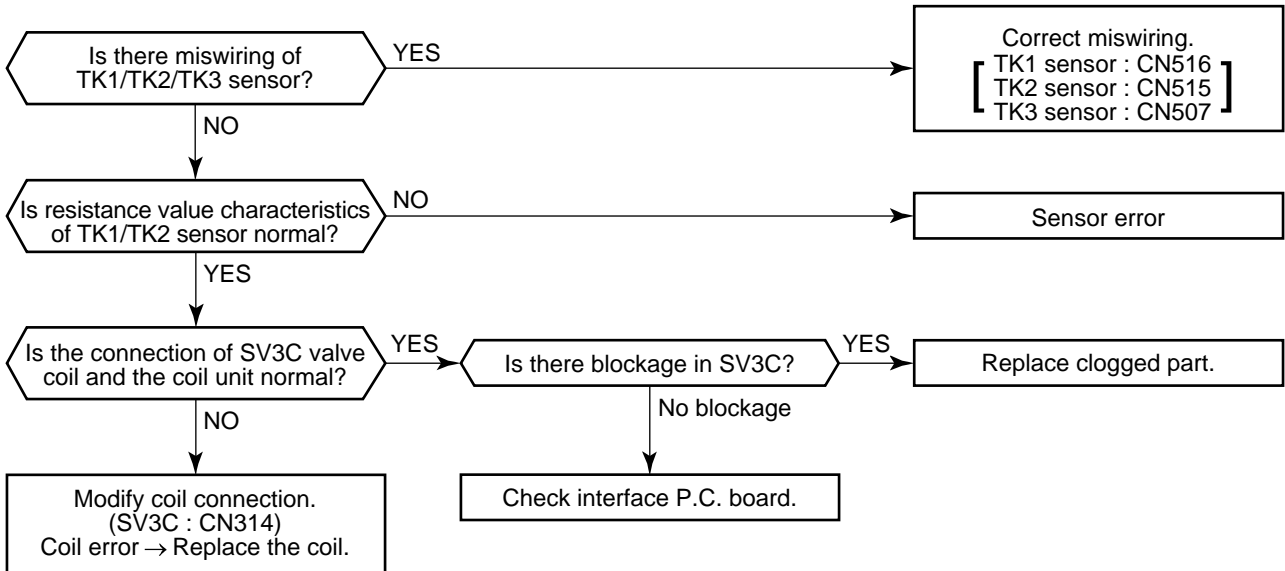

(* 1) SV3C valve blockage check procedure

1. After resetting power supply, start a trial operation.
2. Set SW01/SW02/SW03 on interface P.C. board to 1/16/1, respectively.
3. Check display on the 7 segment of interface P.C. board.

	7 segment display
When operation has started	"OL" "--"
During detection of oil level	"OL" "FF" or "Numeral"
Judgment result of oil level	"OL" "A0" "A1" or "A3"

In case of judgment result "A0" "A1" → Oil level is adequate. Resume the operation.

In case of judgment result "A3" → Possibility of SV3C valve circuit blockage is considered.

Check the following items.

4. Start a trial operation under condition that AC220–240V, 50Hz (**AC220V, 60Hz**) power is on to SV3C valve.
5. During operation, check whether discharge gas flows to the strainer secondary side (A part in the right figure) at upstream of SV3C valve, and SV3C valve secondary side (B part in the right figure).
→ **If blocked part is found, replace the part.**

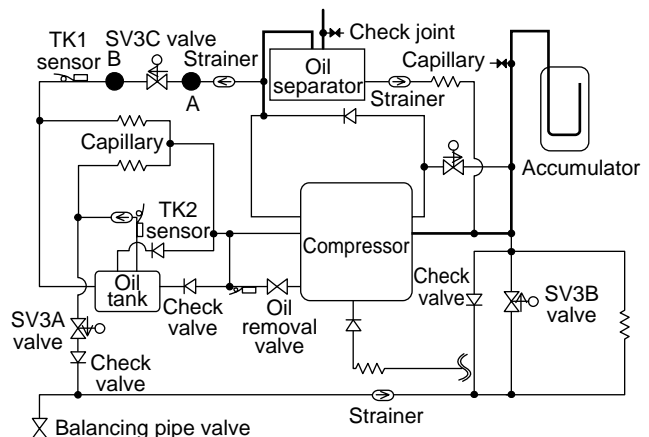

Check code	Operation cause
[dC] Oil level detection circuit leakage detection	1. SV3C valve leakage 2. TK1 sensor resistance value characteristics error 3. Outdoor unit operation in high outside temperature

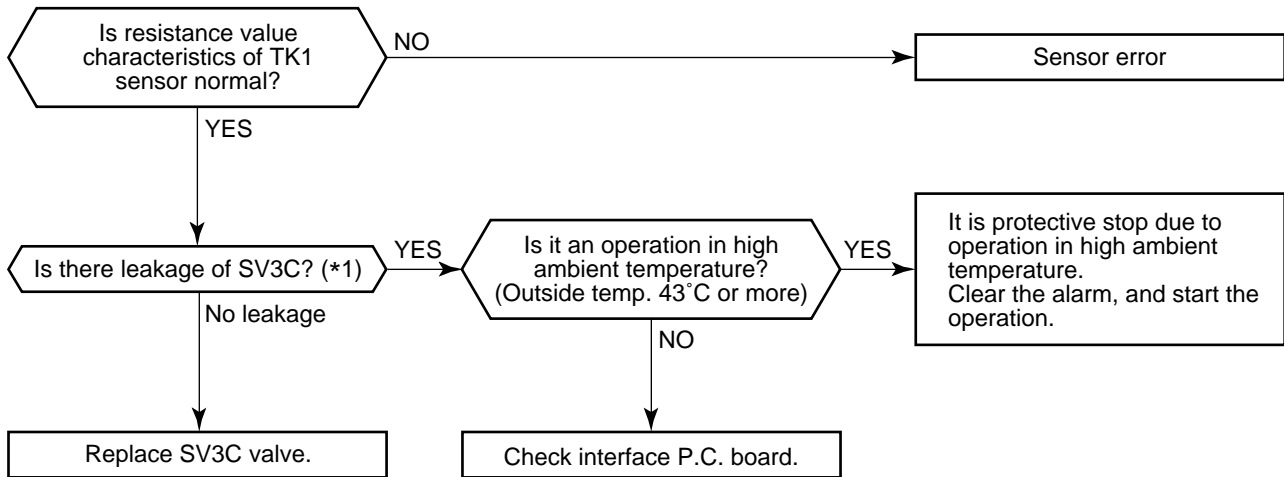

(* 1) SV3C valve leakage check procedure

1. Start a trial operation under condition that connector of SV3C is removed.
2. During operation, check temperature at secondary side of SV3C valve (A part in the following figure).
→ If temperature is high, leakage from SV3C valve is considered.

Replace SV3C valve.

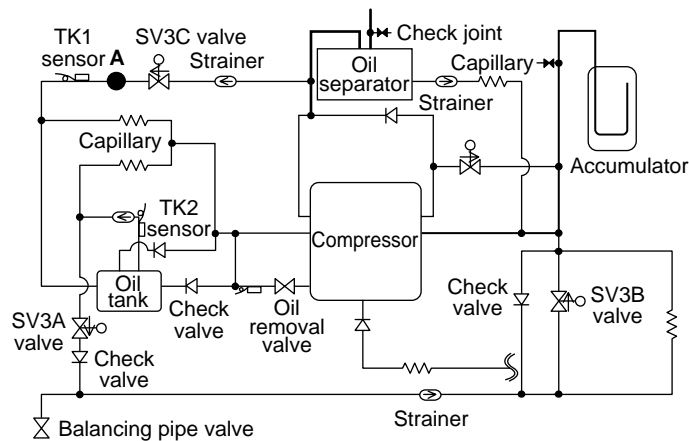

Check code	Operation cause
[dd] Outdoor refrigerant leakage detection	1. Blockage of check valve to interrupt the liquid line. 2. Outdoor PMV A error 3. Pd sensor/Ps sensor error 4. Blockage in SV2 valve circuit 5. Blockage in SV3B valve circuit 6. Blockage in capillary of bypass between gas pipe and heat exchanger line

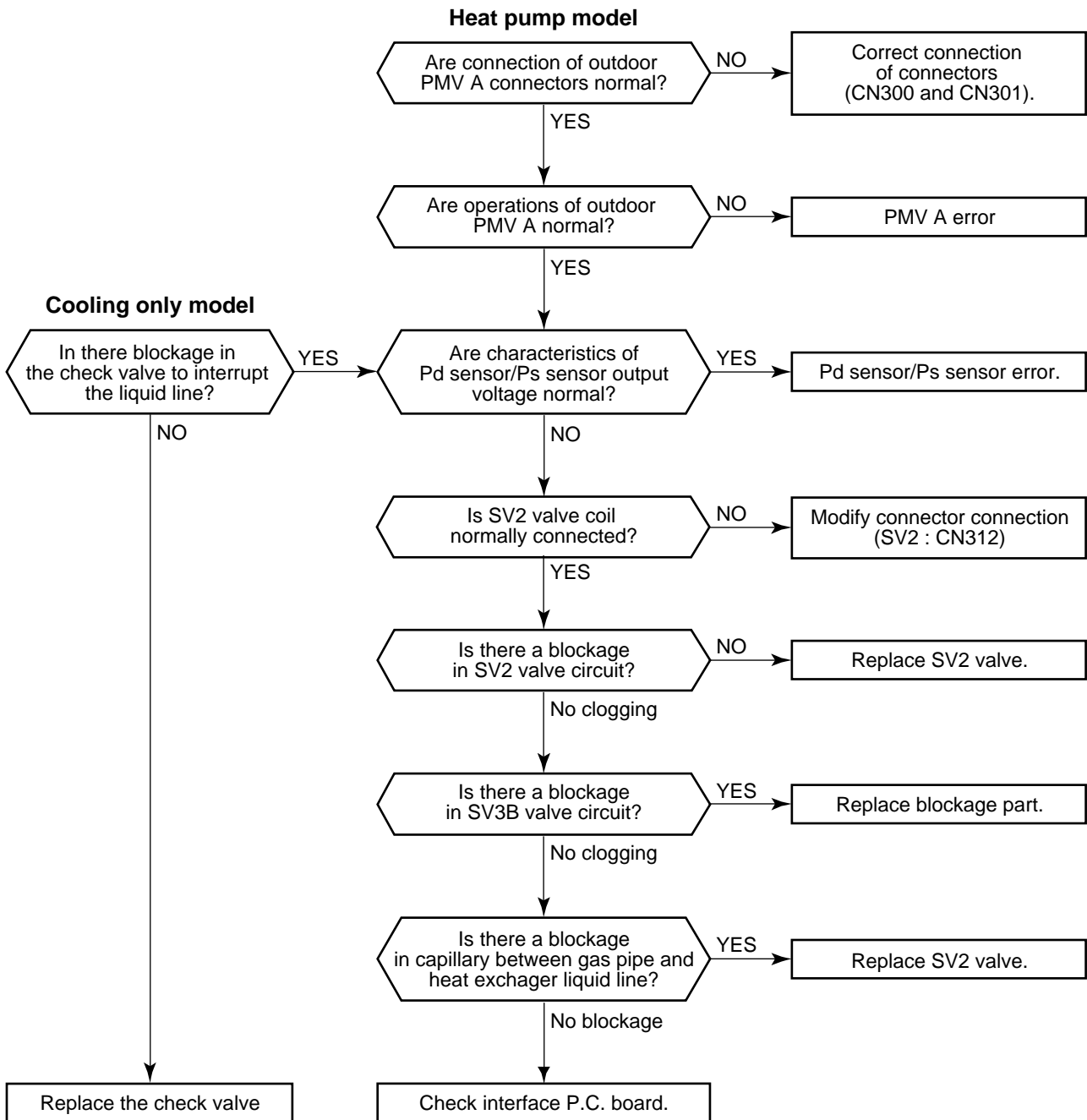

Check code	Operation cause
<p style="text-align: center;">[dE] Indoor address undefined</p>	<ol style="list-style-type: none"> 1. Indoor unit in automatic addressing mode 2. Setting error of indoor main P.C. board (MCC-1361) 3. Indoor main P.C. board (MCC-1361) failure 4. Communication noise

While [dE] check code is displayed, wait for a moment. When the address is defined, the operation is automatically reset. However, if the check code does not disappear 20 minutes have passed after power supply was turned on, a fault is considered. Check the following items.

- Check failure of indoor main P.C. board (MCC-1361).
- Source check of communication noise
- Check faulty setting of jumper line on indoor main P.C. board (MCC-1361).

Check code	Operation cause
<p style="text-align: center;">[dF] Outdoor address undefined</p>	<ol style="list-style-type: none"> 1. Outdoor unit in automatic addressing mode 2. Defective indoor unit interface P.C. board 3. Communication noise

While this check code is displayed, wait for a moment. When the address is defined, the operation is automatically reset. However, if the check code does not disappear 20 minutes have passed after power supply was turned on, a fault is considered. Check the following items.

- Fault check of outdoor unit interface P.C. board
- Source check of communication noise between outdoor units

Check code	Operation cause
<p>[E1] Fixed-speed high-pressure SW system alarm (1)</p> <p>[F0] Fixed-speed high-pressure SW system alarm (2)</p>	<ol style="list-style-type: none"> 1. Fixed-speed compressor high-pressure SW error 2. Fixed-speed compressor IOL operation 3. Service valve closed 4. Outdoor fan capacitor error 5. Indoor/Outdoor PMV blockage 6. Outdoor heat exchanger blockage 7. SV2 circuit blockage 8. Miswiring of communication between indoor and outdoor unit 9. Pd sensor error 10. Refrigerant over-charge

[E1] : High-pressure SW system error at compressor 1 side
[F0] : High-pressure SW system error at compressor 2 side

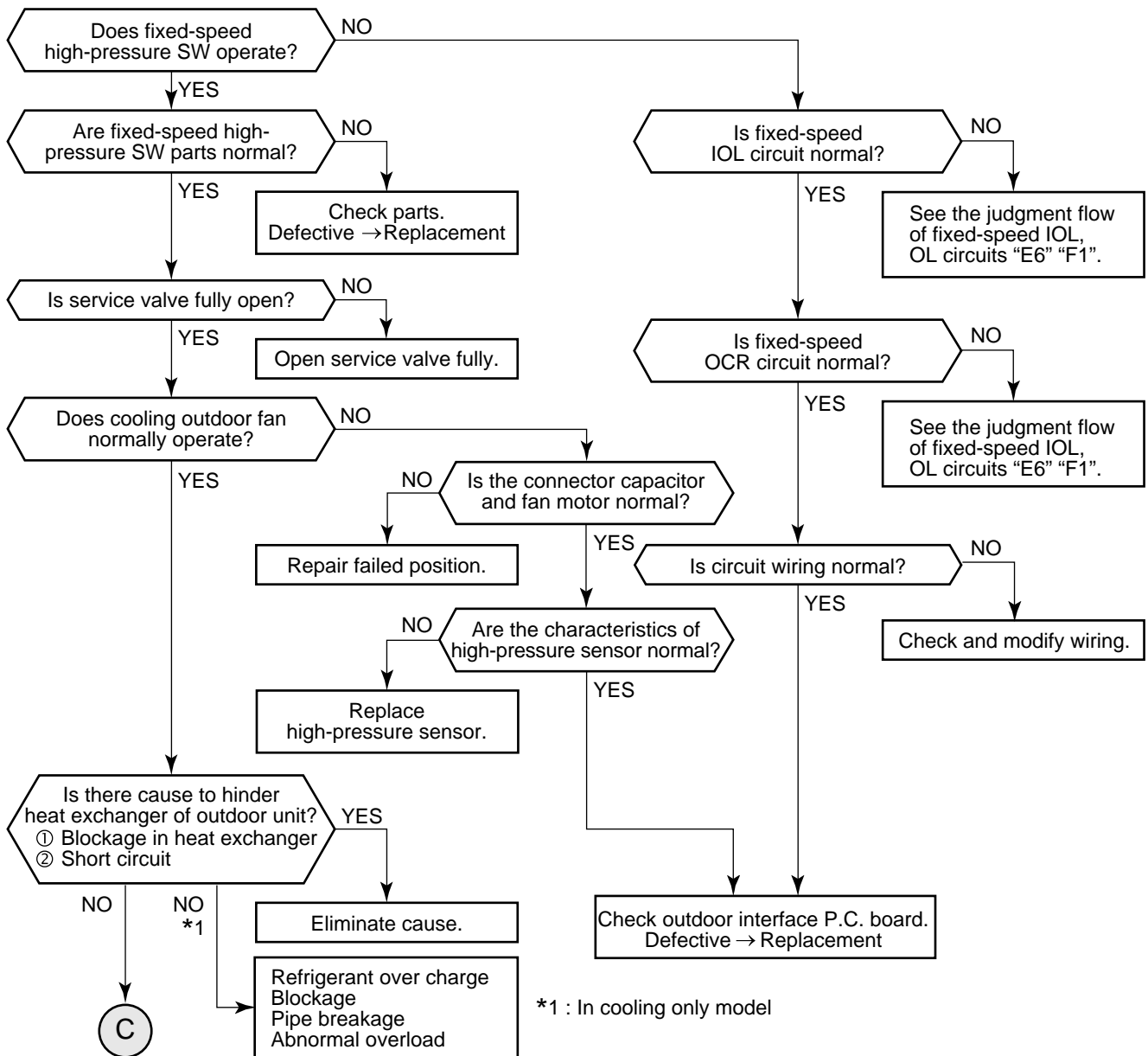

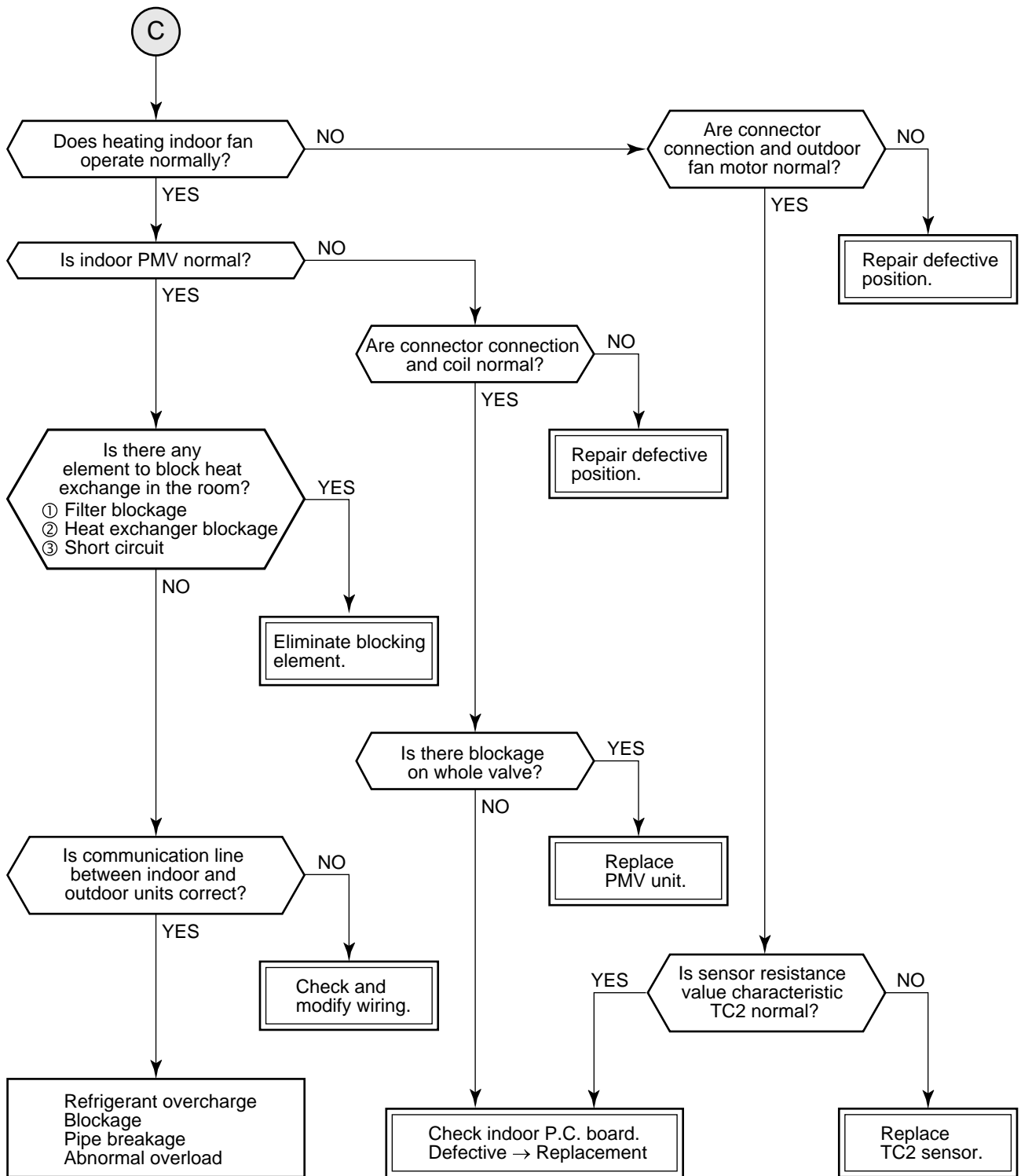

Check code	Operation cause
[E5] Inverter IOL operation	1. Inverter IOL operation 2. Service valve closed 3. Outdoor PMV A error or cooling bypass PMV B error 4. Miswiring of communication between indoor and outdoor unit

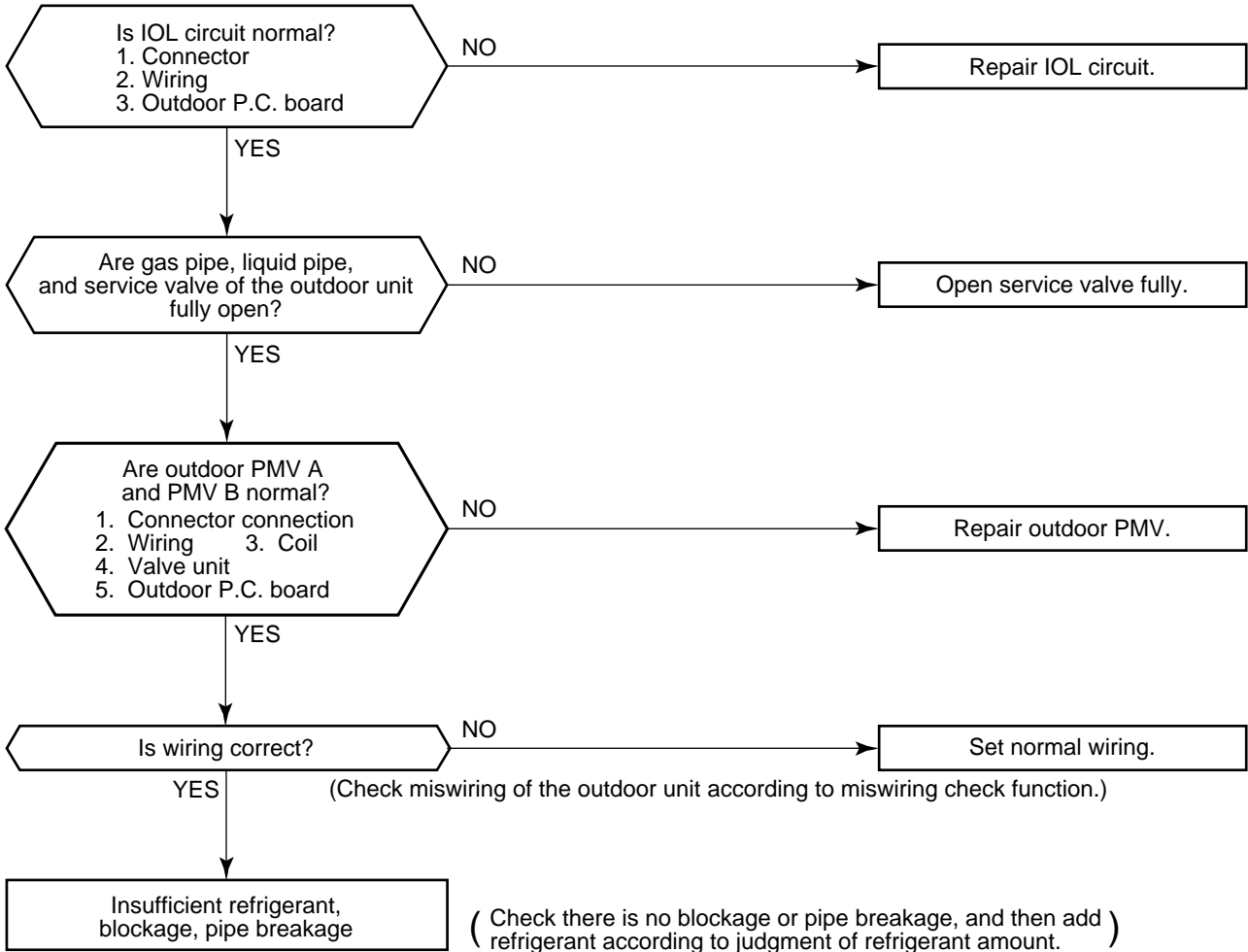

Check code	Operation cause
[E6] Fixed-speed IOL, OL system alarm (1) [F1] Fixed-speed IOL, OL system alarm (2)	1. Power supply error 2. Fixed-speed compressor IOL operation 3. Service valve closed 4. Blockage in indoor PMV/outdoor PMV A, PMV B 5. Miswiring of communication between indoor and outdoor unit

[E6] : IOL operation circuit error at compressor 1 side
 [F1] : IOL operation circuit error at compressor 2 side

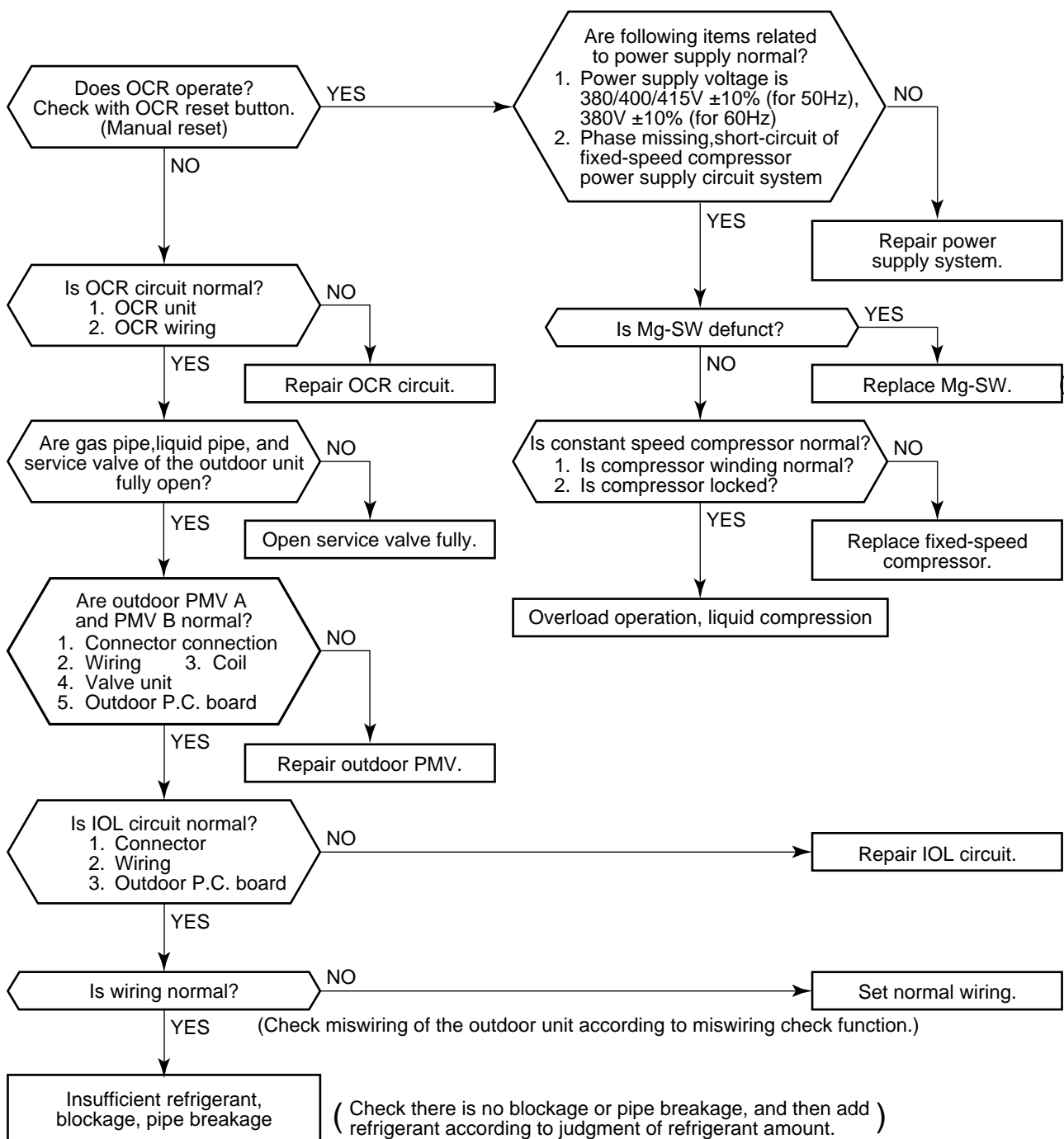

3-6-5. 7 Segment Display Function

3-6-5-1. Outdoor unit 7 segment display (Interface P.C. board)

A 7 segment LED to check the operation status is provided on the interface control P.C. board. The display contents can be selected by combining the set up numbers of the rotary switches (SW01, SW02, and SW03) on the P.C. board.

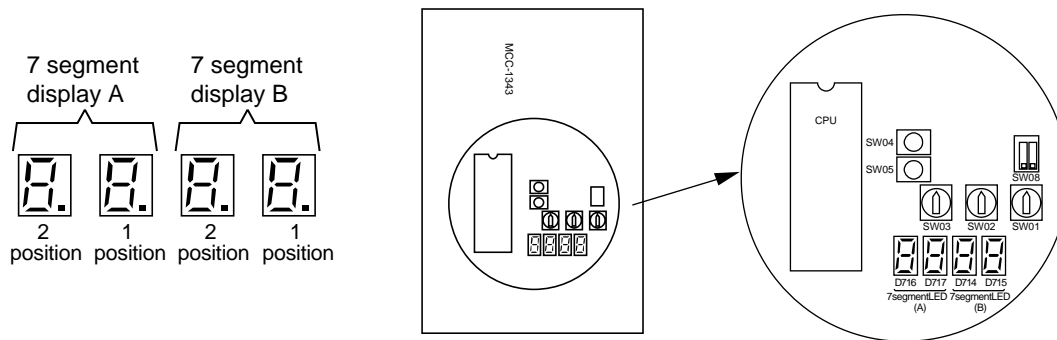

Check Procedure when Emergency Stop has Occurred

When the system stopped due to an error of the outdoor unit, check the following items.

- (1) Open panel of the inverter outdoor unit, and check the 7 segment display.
A check code is displayed at the right side of the 7 segment display.
[U1] [nn] (nn : Check code)
(Switch set up when checking the check code : SW01 [1], SW02 [1], SW03 [1])
- (2) Confirm the check code, and implement check operation according to the Troubleshooting guide for each check code.
- (3) If [U1] [d2] are displayed on the 7 segment display, an error occurs on the fixed-speed outdoor unit.
Push the push-switch SW04 of the inverter outdoor unit for several seconds. Only the outdoor fan in which error occurred operates, open the panel of the unit of which fan operated, and check the check code displayed on the 7 segment.
- (4) Implement check operation according to the Troubleshooting guide for each check code.

(1) System information data display (Displayed on the inverter unit only)

SW03	SW02	SW01	Displayed content				
3	1	1	Use refrigerant	Type of use refrigerant is displayed		A	B
				• In case of R22 model		22	
				• In case of R407C model		40	7C
	2	Outdoor system capacity	A	[8] to [46] : 8 to 46HP			
			B	[HP]			
	3	No. of connected outdoor units	A	[1] to [5] : 1 to 5 units			
			B	[P]			
	4	No. of connected indoor units	A	[0] to [40] : 0 to 40 units			
			B	[P]			
	5	No. of operating indoor units	A	[0] to [40] : 0 to 40 units			
			B	[P]			
	6	Correction value of compressor command	A	Correction value data is displayed in hexadecimal notation.			
			B				
	7	Release control operation	A	[r] : Normal operation, [r1] : Under release control			
			B	—			
	8	Oil equalizing pattern	A	[OL]			
B			[P] : Normal operation, [P1] to [P3] : Oil equalizing patterns 1 to 3				
9	—	A	—				
		B	—				
10	Refrigerant/Oil recovery operation	A	[C0] : Normal operation, [C1] : Under cooling oil recovery control				
		B	[H0] : Normal operation, [H1] : Under heating refrigerant recovery control				
11	Automatic address	A	[Ad]				
		B	[] : In normal time (Automatic address set up completes.) [11] : Under automatic address set up				
12	—	—					
13	—	—					
14	—	—					
15	—	—					
16	—	—					

(2) Outdoor unit information data display (Displayed on each outdoor unit)

SW03	SW02	SW01	Displayed content					
1	1	1	Check code	A	[U1] to [U5] : Outdoor unit number (1 : Inverter)			
				B	[- -] : Normal time (No error), a check code is displayed in abnormality.			
				<SW04> Push function : Only fan of unit in which an error occurred operates. <SW04 + SW05> Push function : Only fan of normal unit operates. <SW05> Push function : Fan operation function is interrupted.				
			2	Type of installed compressor	A	[U1] to [U2] : Outdoor unit number		
					B	[A] : Fixed-speed 2 in 1, [b] : Fixed-speed 2 compressor [C] : Fixed-speed single, [d] : Inverter (2 in 1)		
			3	Operation mode	A	—		
					B	[C] : Cooling operation, [H] : Heating operation, [J] : Defrost operation		
			4	Outdoor unit capacity	A	[6], [8], [10] : 6, 8, 10 HP		
					B	[HP]		
			5	Compressor operation command	A	[1. -] : No.1 compressor stop status, [1. 1] : During operation For inverter, the frequency code is displayed : [00] to [FF]		
						[2. -] : No.2 compressor stop status, [2. 1] : During operation		
					<SW04> Push function : IPDU frequency data is displayed in decimal notation. <SW05> Push function : Release of frequency data display in decimal notation			
			6	Outdoor fan operation pattern	A	[FP]		
					B	[0] to [16] : 0 wave (stop) to 16 waves (All waves)		
			7	Compressor backup	A	[C1] : Under No.1 compressor backup set up		
					B	[C2] : Under No.2 compressor backup set up		
8	—	A	—					
		B	—					
9	Control valve output			A	B			
		4-way valve : ON / SV2 : OFF		H. 1	2. 0			
10	Control valve output	4-way valve : OFF / SV2 : ON		H. 0	2. 1			
		SV3A : ON / SV3B : OFF / SV3C : OFF		3. 1	0. 0			
		SV3A : OFF / SV3B : ON / SV3C : OFF		3. 0	1. 0			
11	Control valve output	SV3A : OFF / SV3B : OFF / SV3C : ON		3. 0	0. 1			
		SV41 : ON / SV42 : OFF		4.	1. 0			
12	Control valve output	SV41 : OFF / SV42 : ON		4.	0. 1			
		—		—	—			
13	Control valve output	—		—	—			
		—		—	—			
14	PMV 1 + PMV 2 opening	[00] to [A00] : 0 to 1000 pulse		0	0 P			
15	PMV B opening	[00] to [500] : 0 to 500 pulse		0	0 P			
16	Oil level judgment status	A	[OL]					
		B	[.] : Initial display, [FF] : Oil judgment start status [A0] : Adequate, [A1] : Shortage, [A2 to A4] : Detection error					
			<SW04> Push function : Oil level judgment control forcible start (Detection starts after timer count down) <SW05> Push function : Oil level shortage status/Continuous counter display (Displayed for several seconds)					

NOTE : The push-switch function operates by input from the inverter unit.

(3) Outdoor cycle data display (Displayed on each outdoor unit)

SW03	SW02	SW01	Displayed content				
2	1	1	Pd pressure sensor	Pressure sensor data is displayed with (MPaG).	A	B	
							H *
	2		Ps pressure sensor		L *	* *	
	3		TD1 temp. sensor	Temp. sensor data is displayed with (°C). • Symbol display and data display are alternately exchanged every several seconds. • Data is displayed in the part marked with [*]. • If data is negative data, [- * * *] is displayed.	Symbol	t d	1
			Data		*	* *	
	4		TD2 temp. sensor		Symbol	t d	2
			Data		*	* *	
	5		TS temp. sensor		Symbol	t s	
			Data		*	* *	
	6		TE1 temp. sensor		Symbol	t E	1
Data		*	* *				
7	—						
8	TK1 temp. sensor	Symbol	F 1				
	Data	*	* *				
9	TK2 temp. sensor	Symbol	F 2				
	Data	*	* *				
10	TK3 temp. sensor	Symbol	F 3				
	Data	*	* *				

(4) Outdoor cycle data display (Displayed on inverter unit)

* Outdoor cycle data display is used when the fixed-speed unit information is displayed on the 7 segment section of the inverter unit.

SW03	SW02	SW01	Displayed content	
1 to 4	1	3	Check code	A [U2] to [U5] : Outdoor unit number (Set up with SW03)
				B [- -] : Normal time (No trouble), a check code is displayed in abnormality.
	2		Type of fixed-speed compressor	A [U2] to [U5] : Outdoor unit number (Set up with SW03)
				B [A] : Fixed-speed 2 in 1 compressor [b] : Fixed-speed 2 compressor [C] : Fixed-speed single compressor
	3		Fixed-speed unit capacity	A [U2] to [U5] : Outdoor unit number (Set up with SW03)
				B [6], [8], [10] : 6, 8, 10HP
	4		Fixed-speed compressor operation command	A [U2] to [U5] : Outdoor unit number (Set up with SW03)
				B [10] : No.1 compressor start/No.2 compressor stop status [01] : No.1 compressor stop/No.2 compressor start status
	5		—	A [U2] to [U5] : Outdoor unit number (Set up with SW03)
				B —
	6		—	A [U2] to [U5] : Outdoor unit number (Set up with SW03)
				B —
	7		Oil level judgment status	A [U2] to [U5] : Outdoor unit number (Set up with SW03)
				B [] : Normal time, [L] : Shortage

NOTE : The outdoor unit number is set by selecting SW03.

SW03	Outdoor unit number	7 segment display A
1	Outdoor No.2 unit (Fixed-speed 1)	[U2]
2	Outdoor No.3 unit (Fixed-speed 2)	[U3]
3	Outdoor No.4 unit (Fixed-speed 3)	[U4]
4	Outdoor No.5 unit (Fixed-speed 4)	[U5]

(5) Indoor unit information data display (Displayed on inverter unit only)

SW03	SW02	SW01	Displayed content		
1 to 3	1 to 16	4	Indoor communication/Receive status	A	[01] to [48] : Indoor address number
				B	[1] : Receiving, [- -] : No connection
		5	Indoor check code	A	[01] to [48] : Indoor address number
				B	[- -] : No trouble, a check code is displayed when a trouble occurred.
		6	Indoor horse power	A	[01] to [48] : Indoor address number
				B	Corresponded HP is displayed. ([- -] : No connection) [0, 8], [1], [1, 2], [1, 5], [1, 7], [2] [2, 5], [3], [3, 2], [4], [5], [6]
		7	Indoor demand command (S code)	A	[01] to [48] : Indoor address number
				B	[0] : In STOP time, [3] to [F] : During operation (S3 to SF)
		8	Indoor PMV opening	A	[01] to [48] : Indoor address number
				B	Data is displayed in hexadecimal notation
		9	Indoor saturation temp.	A	[01] to [48] : Indoor address number
				B	Data is displayed in hexadecimal notation.
		10	Indoor TA sensor	A	[01] to [48] : Indoor address number
				B	Data is displayed in hexadecimal notation.
		11	Indoor TC2 sensor	A	[01] to [48] : Indoor address number
				B	Data is displayed in hexadecimal notation.
		12	Indoor TC1 sensor	A	[01] to [48] : Indoor address number
				B	Data is displayed in hexadecimal notation.

NOTE : The indoor address number is set by selecting SW02 or SW03.

SW03	SW02	Indoor address	7 segment display A
1	1 to 16	SW02 set up number	[01] to [16]
2	1 to 16	SW02 set up number + 16	[17] to [32]
3	1 to 16	SW02 set up number + 32	[33] to [48]

- 7 segment display A, B

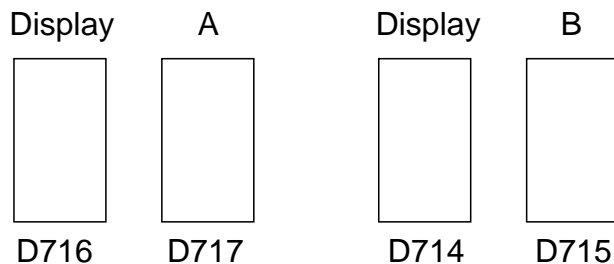

3-6-6. Sensor Characteristics

3-6-6-1. Temperature sensor characteristics

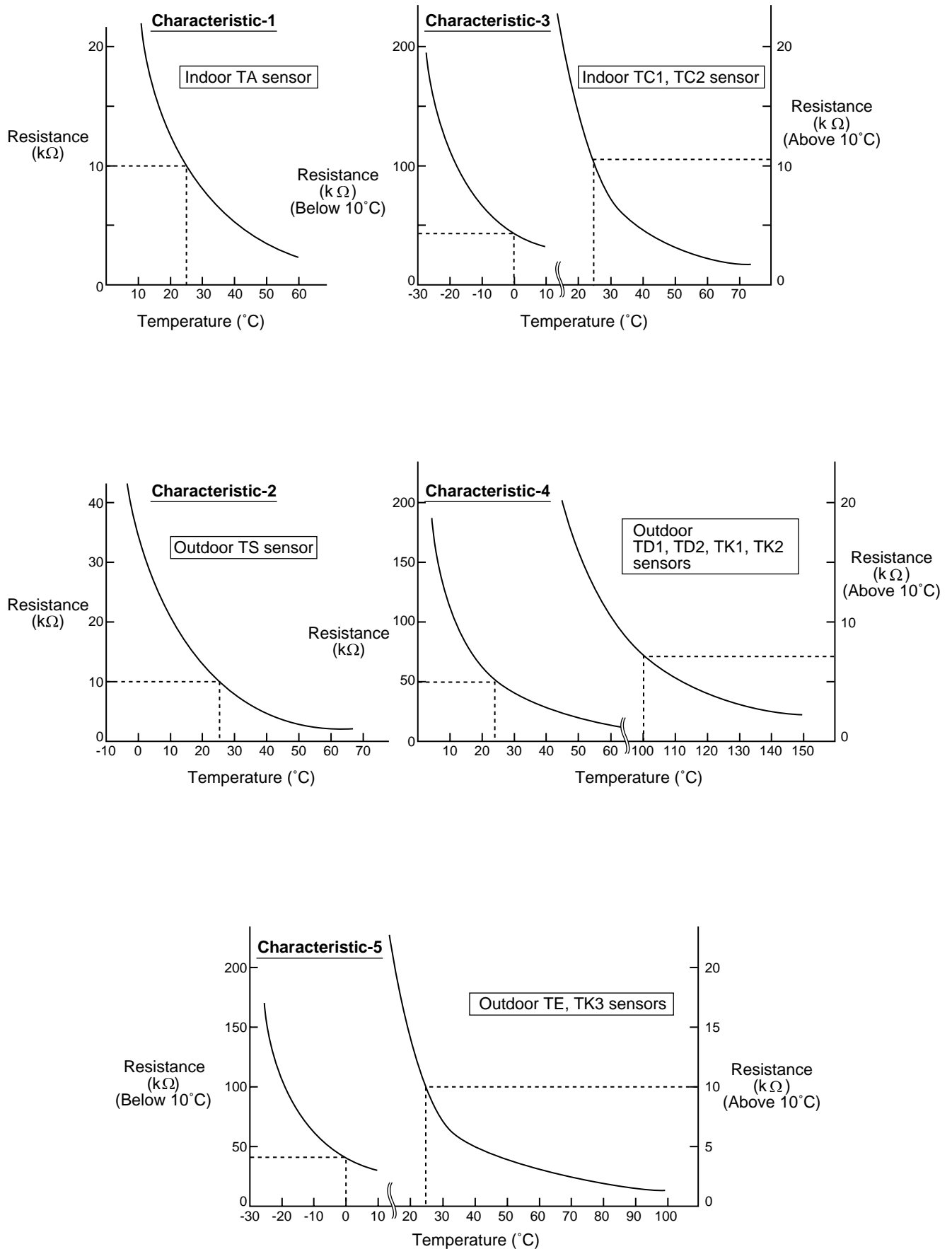

3-6-6-2. Pressure sensor characteristics

■ Outdoor unit

<Input/Output wiring connection table>

Pin No.	High pressure side (Pd)		Low pressure side (Ps)	
	I/O name	Lead wire color	I/O name	Lead wire color
1	Output	White	—	—
2	—	—	Output	White
3	GND	Black	GND	Black
4	+ 5V	Red	+ 5V	Red

<Output voltage - Pressure>

High pressure side (Pd)	Low pressure side (Ps)
0.5 to 3.9V 0 to 3.33MPa	0.5 to 3.5V 0 to 0.98MPa

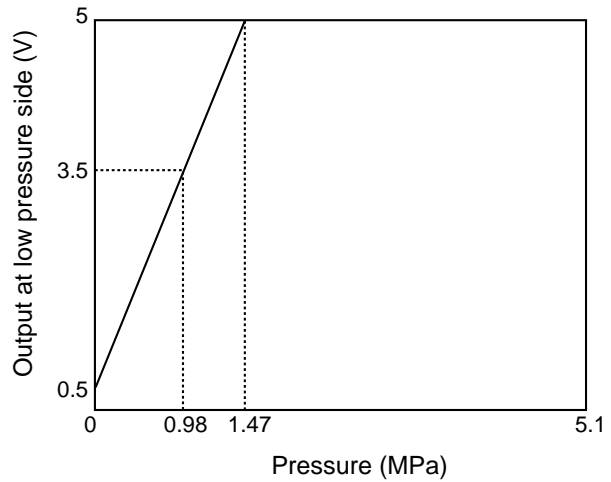
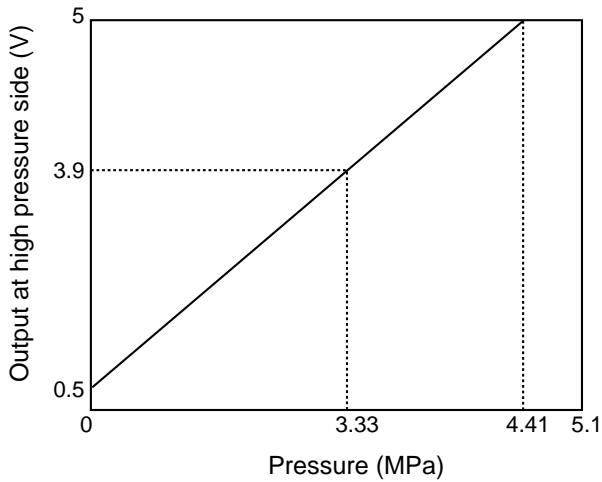

■ Indoor unit

<Input/Output wiring connection table>

Pin No.	I/O name	Lead wire color	Pin No.	I/O name	Lead wire color
1	GND	Black	4	OUT (Low pressure side)	Green
2	OUT (High pressure side)	White	5	—	—
4	—	—	6	+ 12.0V	Red

<Output voltage - Pressure>

High pressure side (Pd)	Low pressure side (Ps)
0.5 to 4.5V 0 to 2.45MPa	0.5 to 4.5V 0 to 0.82MPa

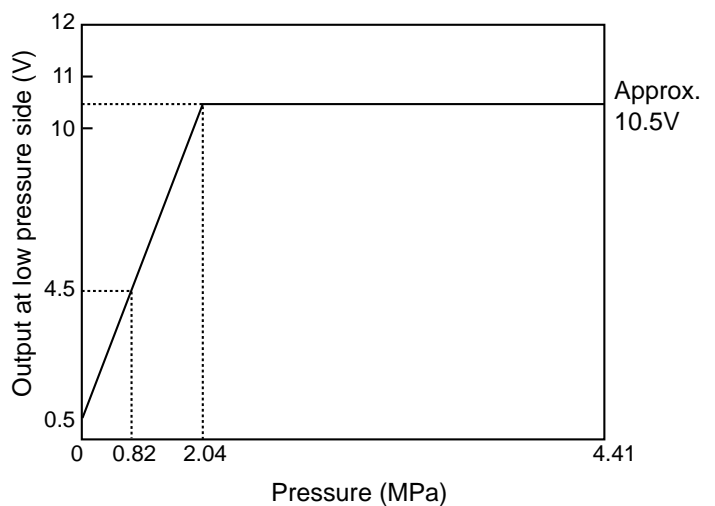
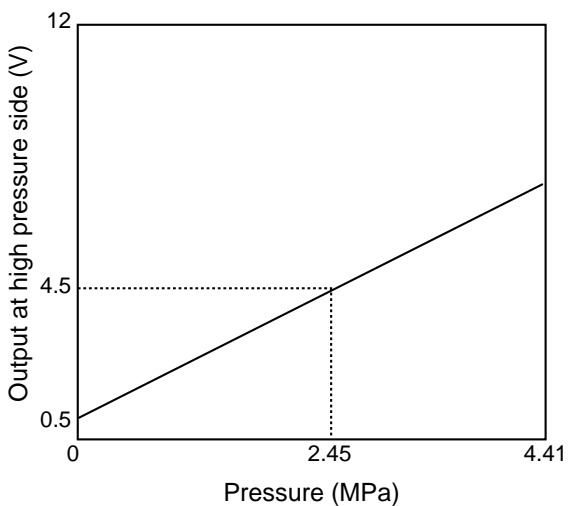

3-7. CONTROL CIRCUIT CONFIGURATION

3-7-1. Indoor Unit

3-7-1-1. Indoor control block diagram (MCC-1361 : Main P.C. board) 4-way air discharge cassette type

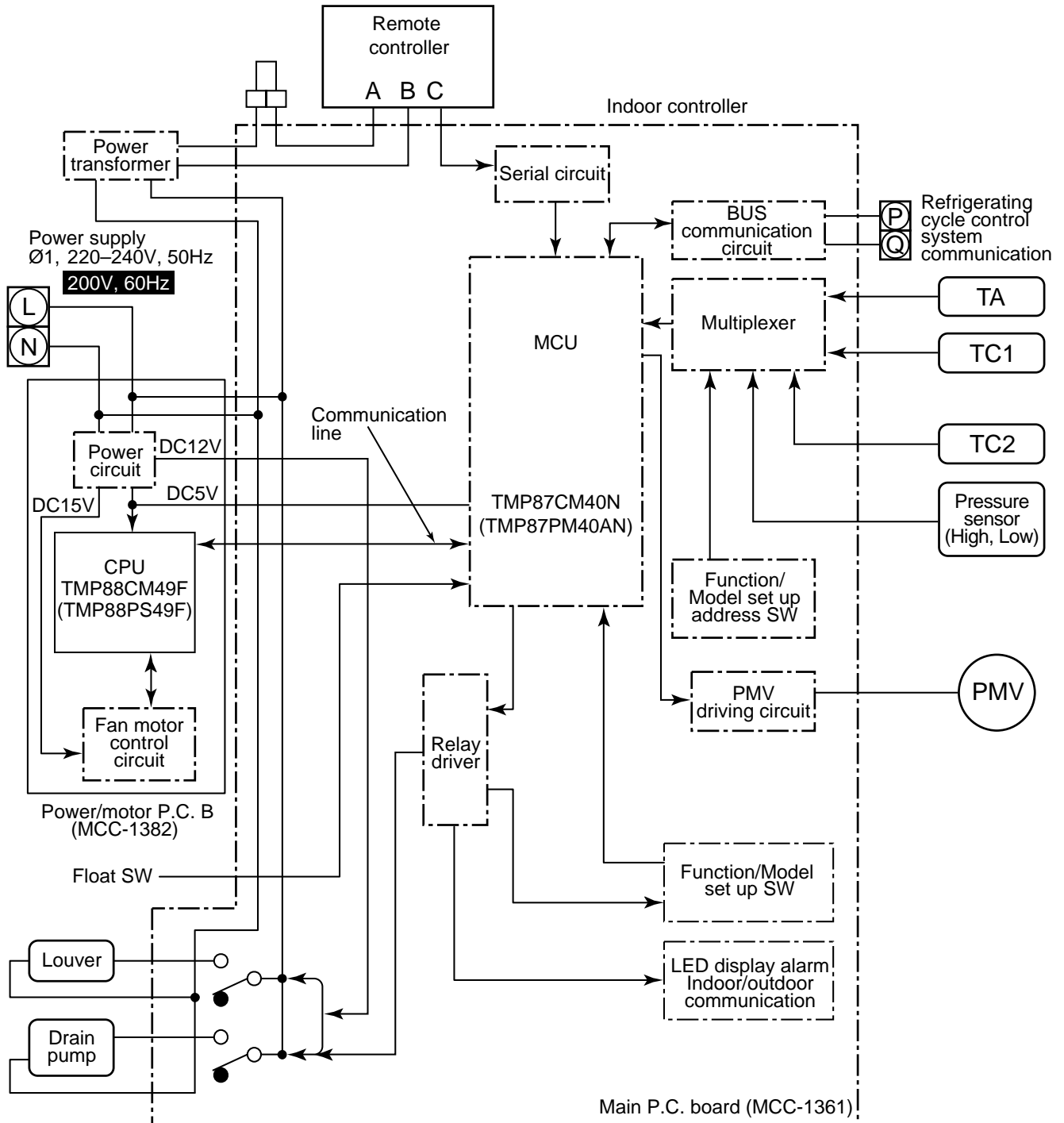

NOTE :

The P.C. board of the indoor unit is divided into two boards for each function.

1. Main P.C. board (MCC-1361) Controller for entire units (PMV, louver, drain pump, etc.)
2. Power/Motor P.C. board (MCC-1382) Power supply circuit, fan motor drive part

3-7-1-2. Indoor control block diagram (MCC-1361 : Main P.C. board) 2-way air discharge cassette, Concealed duct type

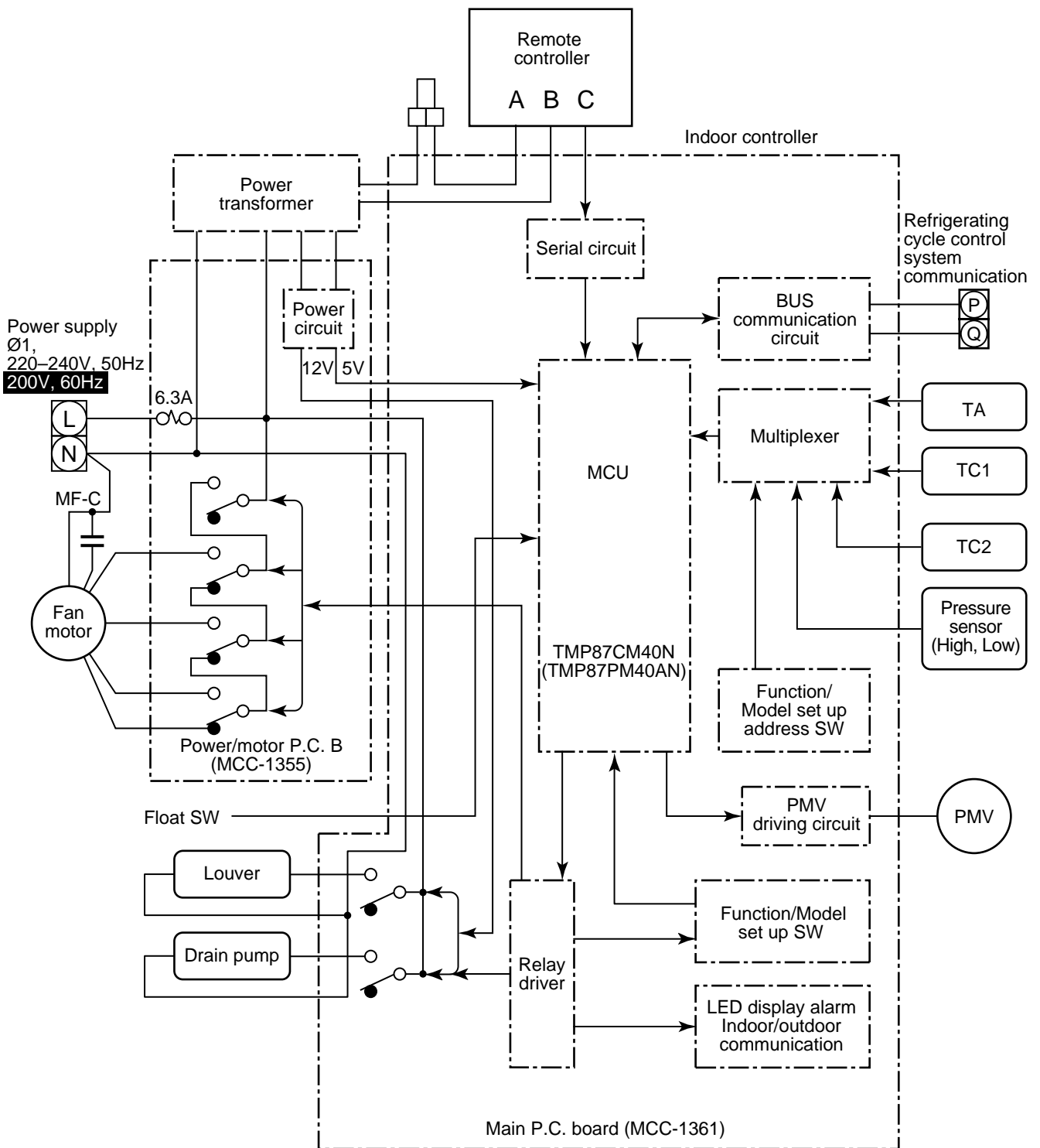

NOTE :

- The P.C. board of the indoor unit is divided into two boards for each function.
1. Main P.C. board (MCC-1361) Controller for entire units (PMV, louver, drain pump, etc.)
 2. Power/Motor P.C. board (MCC-1355) Power supply circuit, fan motor drive part

3-7-1-3. Indoor control block diagram (MCC-1361 : Main P.C. board) High wall type

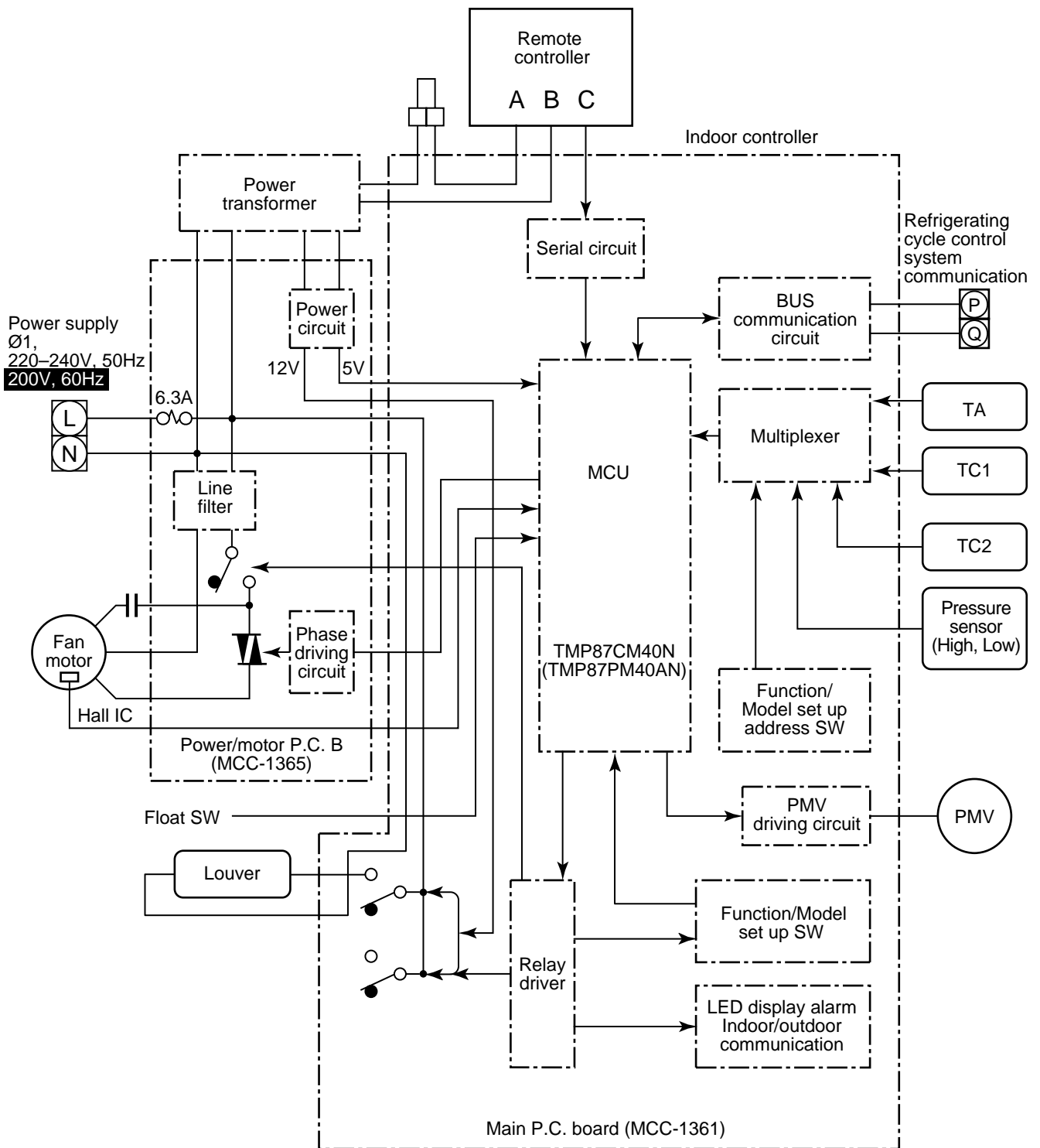

NOTE :

- The P.C. board of the indoor unit is divided into two boards for each function.
1. Main P.C. board (MCC-1361) Controller for entire units (PMV, louver, drain pump, etc.)
 2. Power/Motor P.C. board (MCC-1365) Power supply circuit, fan motor drive part

3-7-1-4. LED display on indoor P.C. board

<General type>

Part No.	Color	Displayed content	Details
D13	Orange	Serial receive	Flashes synchronized with the receive signal from the standard remote controller.
D11	Green	Serial send	Flashes synchronized with the send signal to the standard remote controller.
D22	Red	Alarm stop display	Goes on when the indoor unit stops with fault.
D51	Yellow	Cycle communication	Flashes synchronized with receive signal from the outdoor unit.

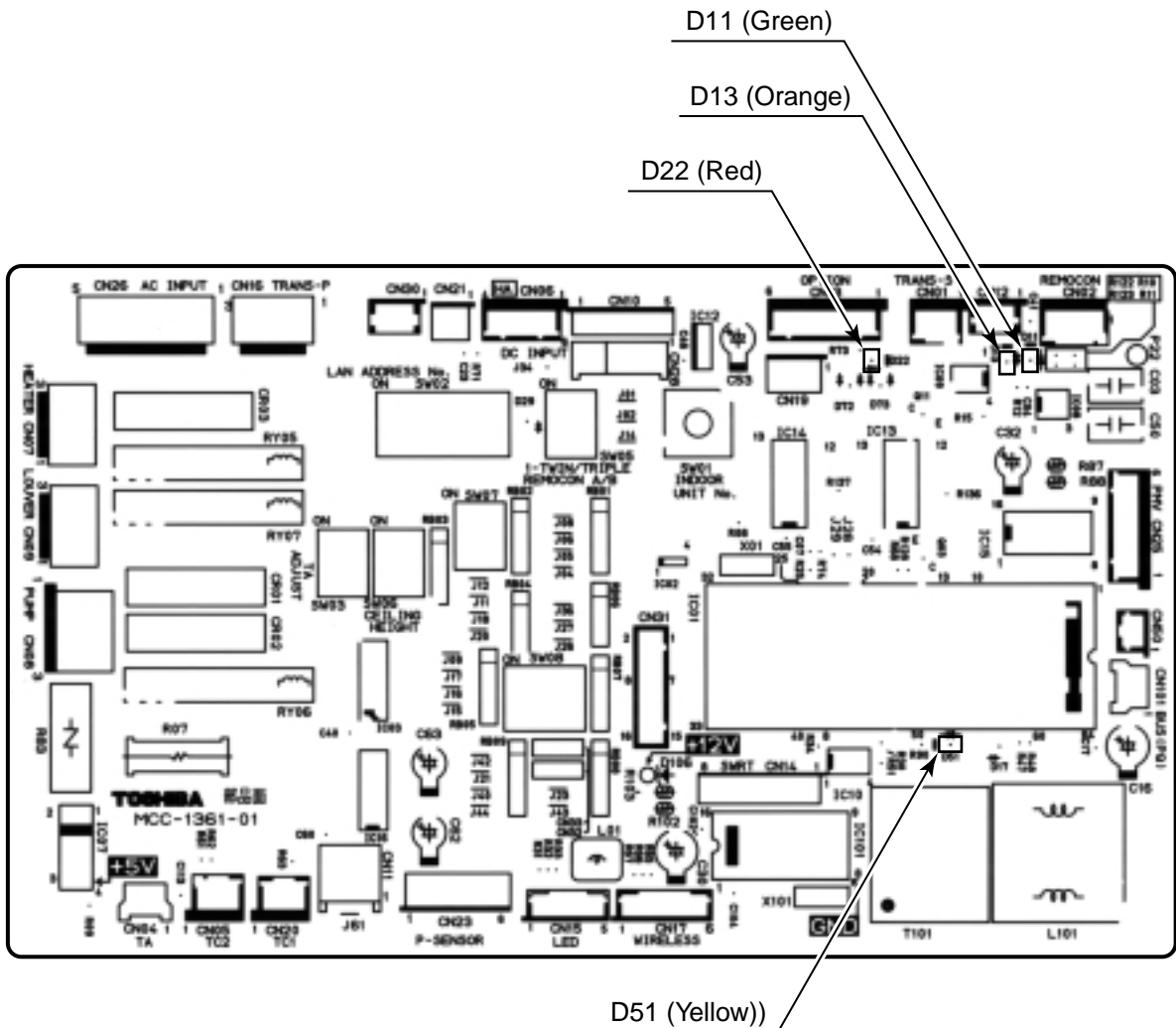

Indoor P.C. board parts layout drawing

<For 4-way Air Discharge Cassette type> (MCC-1382)

Part No.	Color	Displayed content	Details
D63	Red	Communication error between MCU	Flashes when communication to/from the main P.C. board is failed.

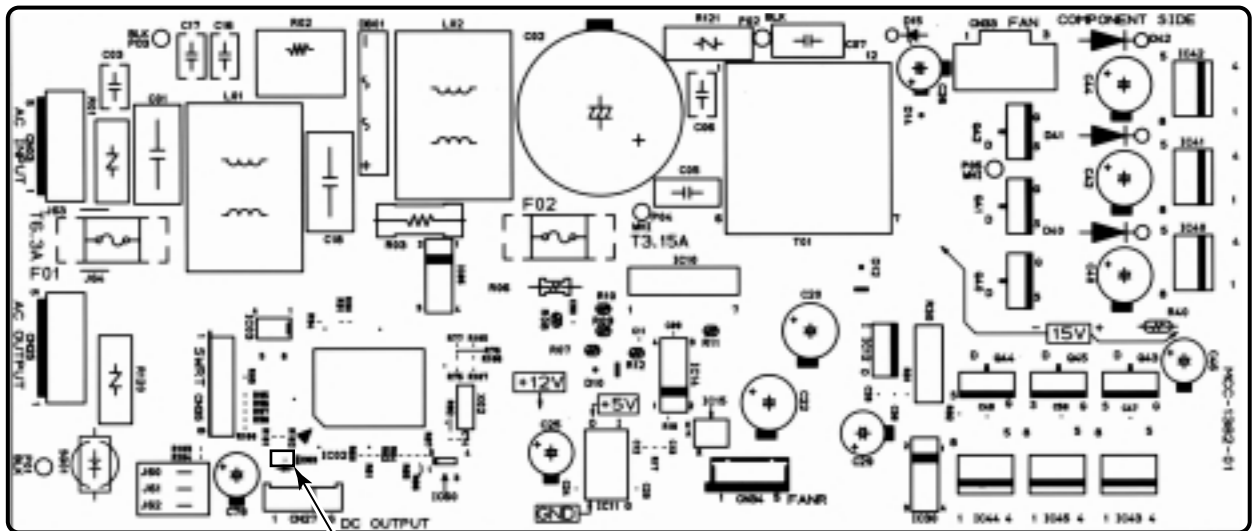

Indoor main P.C. board parts layout drawing (MCC-1382)

3-7-1-5. Display on remote controller

In the following conditions, "STANDBY" is displayed on the remote controller.

1) "STANDBY" display

Fan operation is available, but PMV of the indoor unit is not opened. (Refrigerant does not flow.)

a. Indoor unit capacity over

When the total horse power of the indoor units exceeds 1.35 times of outdoor horse power, the indoor unit enters STANDBY status.

The check code "89" is displayed at the same time when "STANDBY" is displayed.

b. Outdoor unit phase order error

If phase order of power supply of the outdoor unit is different, the indoor unit enters STANDBY status.

The check code "AF" is displayed at the same time when "STANDBY" is displayed.

* c. Outdoor heating priority

While the outdoor unit operates in HEAT mode, the indoor unit which was set to COOL mode enters STANDBY status.

No check code is displayed though "STANDBY" is displayed.

* d. Cooling only operation of outdoor unit

When the outdoor unit is set to COOLING only operation mode, the indoor unit which was set to HEAT mode enters STANDBY status.

No check code is displayed though "STANDBY" is displayed.

e. Indoor operation below 0.8HP control

When the total horse power of the operating indoor units is below 0.8HP, the indoor unit which operation is set up enters STANDBY status. "STANDBY" is displayed though the check code is not displayed.

Check setting of SW08 on the indoor main P.C. board (MCC-1349).

* 2) "PRE HEAT, DEFROST" display

In this time, there is possibility to stop the fan operation.

a. Cold draft protective control (Hot start)

If the indoor heat exchanger is not sufficiently heated when heating operation has started (or thermostat-ON), "PRE HEAT, DEFROST" is displayed.

After the heat exchanger has sufficiently heated, "PRE HEAT, DEFROST" display disappears and the fan starts operation.

b. Heating refrigerant/Oil recovery control

When the outdoor unit starts heating refrigerant and oil recovery control, an indoor unit which enters other mode than HEAT or of which heating thermostat is off stops operation of the fan and displays "PRE HEAT, DEFROST".

On the indoor unit of which fan stops, "PRE HEAT, DEFROST" is not displayed.

(* : The description is applied to the Heat Pump model only.)



3-7-1-6. Indoor PMV full open/full close function

PMV used in the indoor unit can be forcibly opened fully, closed fully, and opened in medium degree for 2 minutes.

[4-way Air Discharge Cassette type]

CN33	CN32	PMV opening
Open	Open	Normal operation
Open	Short	Full open
Short	Open	Full close
Short	Short	Medium opening (Medium degree of full open and full close)

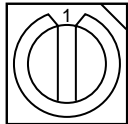
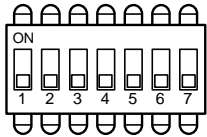
3-7-1-7. Switch positions at shipment from the factory

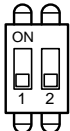
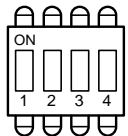
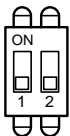
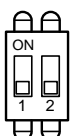
SW No.	Function	Description	Position at shipment from factory								
SW01	Indoor unit No. set up	Group operation control set up 1 : Master unit 2 to 16 Server units									
SW02	Network address set up	<table border="1"> <tr> <td rowspan="2">No. 7</td> <td>ON</td> <td>Address set up by remote controller is unavailable.</td> </tr> <tr> <td>OFF</td> <td>Address set up by remote controller is available.</td> </tr> </table> <p>For contents of address set up, see the next page.</p>	No. 7	ON	Address set up by remote controller is unavailable.	OFF	Address set up by remote controller is available.				
No. 7	ON	Address set up by remote controller is unavailable.									
	OFF	Address set up by remote controller is available.									
SW03 (*)		<table border="1"> <tr> <td>No. 1</td> <td>ON</td> <td>Normal</td> </tr> <tr> <td>No. 2</td> <td>OFF</td> <td>Normal</td> </tr> </table>	No. 1	ON	Normal	No. 2	OFF	Normal			
No. 1	ON	Normal									
No. 2	OFF	Normal									
SW05 (*)		<table border="1"> <tr> <td>No. 1</td> <td>OFF</td> <td>Normal</td> </tr> <tr> <td>No. 2</td> <td>OFF</td> <td>Normal</td> </tr> </table>	No. 1	OFF	Normal	No. 2	OFF	Normal			
No. 1	OFF	Normal									
No. 2	OFF	Normal									
SW08	Indoor horse power set up	Set up at shipment from factory For contents of set up, see the next page.									
SW06	Ceiling height select set up	When height of ceiling exceeds 2.7m, set No.1 to ON side.									
SW07	Central control switching	<table border="1"> <tr> <td rowspan="2">No. 1</td> <td>ON</td> <td>Impossible to communication (Non relay)</td> </tr> <tr> <td>OFF</td> <td>(Normal) possible to communication</td> </tr> <tr> <td>No. 2</td> <td>OFF</td> <td>Normal</td> </tr> </table>	No. 1	ON	Impossible to communication (Non relay)	OFF	(Normal) possible to communication	No. 2	OFF	Normal	
No. 1	ON	Impossible to communication (Non relay)									
	OFF	(Normal) possible to communication									
No. 2	OFF	Normal									

REFERENCE : * marked switches are not used for intelligent variable refrigerant system air conditioner.

3-7-1-8. Contents of switch set up

Network address set up table by DIP switch (SW02)

- After turning off the power supply, set 7 of DIP switch (SW02) to ON side.

Address set up from the remote controller becomes unavailable.

(All the switches are set to OFF (Numeral) side at shipment from the factory. * Address No.1)

Address No.	DIP switch (SW02)					
	1	2	3	4	5	6
1	X	X	X	X	X	X
2	○	X	X	X	X	X
3	X	○	X	X	X	X
4	○	○	X	X	X	X
5	X	X	○	X	X	X
6	○	X	○	X	X	X
7	X	○	○	X	X	X
8	○	○	○	X	X	X
9	X	X	X	○	X	X
10	○	X	X	○	X	X
11	X	○	X	○	X	X
12	○	○	X	○	X	X
13	X	X	○	○	X	X
14	○	X	○	○	X	X
15	X	○	○	○	X	X
16	○	○	○	○	X	X
17	X	X	X	X	○	X
18	○	X	X	X	○	X
19	X	○	X	X	○	X
20	○	○	X	X	○	X
21	X	X	○	X	○	X
22	X	X	○	X	○	X
23	X	○	○	X	○	X
24	○	○	○	X	○	X
25	X	X	X	○	○	X
26	○	X	X	○	○	X
27	X	○	X	○	○	X
28	○	○	X	○	○	X
29	X	X	○	○	○	X
30	○	X	○	○	○	X
31	X	○	○	○	○	X
32	○	○	○	○	○	X

Address No.	DIP switch (SW02)					
	1	2	3	4	5	6
33	X	X	X	X	X	○
34	○	X	X	X	X	○
35	X	○	X	X	X	○
36	○	○	X	X	X	○
37	X	X	○	X	X	○
38	X	X	○	X	X	○
39	X	○	○	X	X	○
40	○	○	○	X	X	○
41	X	X	X	○	X	○
42	○	X	X	○	X	○
43	X	○	X	○	X	○
44	○	○	X	○	X	○
45	X	X	○	○	X	○
46	○	X	○	○	X	○
47	X	○	○	○	X	○
48	○	○	○	○	X	○
49	X	X	X	X	○	○
50	○	X	X	X	○	○
51	X	○	X	X	○	○
52	○	○	X	X	○	○
53	X	X	○	X	○	○
54	○	X	○	X	○	○
55	X	○	○	X	○	○
56	○	○	○	X	○	○
57	X	X	X	○	○	○
58	○	X	X	○	○	○
59	X	○	X	○	○	○
60	○	○	X	○	○	○
61	X	X	○	○	○	○
62	○	X	○	○	○	○
63	X	○	○	○	○	○
64	○	○	○	○	○	○

Indoor unit horse power set up table by DIP switch (SW08)

SW08				Selected content
1	2	3	4	
X	X	X	X	Indoor capacity 0.2 HP
X	X	X	○	Indoor capacity 0.5 HP
X	X	○	X	Indoor capacity 0.8 HP
X	X	○	○	Indoor capacity 1.0 HP
X	○	X	X	Indoor capacity 1.25 HP
X	○	X	○	Indoor capacity 1.5 HP
X	○	○	X	Indoor capacity 1.7 HP
X	○	○	○	Indoor capacity 2.0 HP

SW08				Selected content
1	2	3	4	
○	X	X	X	Indoor capacity 2.5 HP
○	X	X	○	Indoor capacity 3.0 HP
○	X	○	X	Indoor capacity 3.2 HP
○	X	○	○	Indoor capacity 4.0 HP
○	○	X	X	Indoor capacity 5.0 HP
○	○	X	○	Indoor capacity 6.0 HP
○	○	○	X	Indoor capacity 8.0 HP
○	○	○	○	Indoor capacity 10.0 HP

NOTE : ○ : ON side X : OFF (Numeral) side

3-7-2. Indoor Printed Circuit Board (P.C. Board)
 3-7-2-1. Main P.C. Board
 ■ MCC-1361

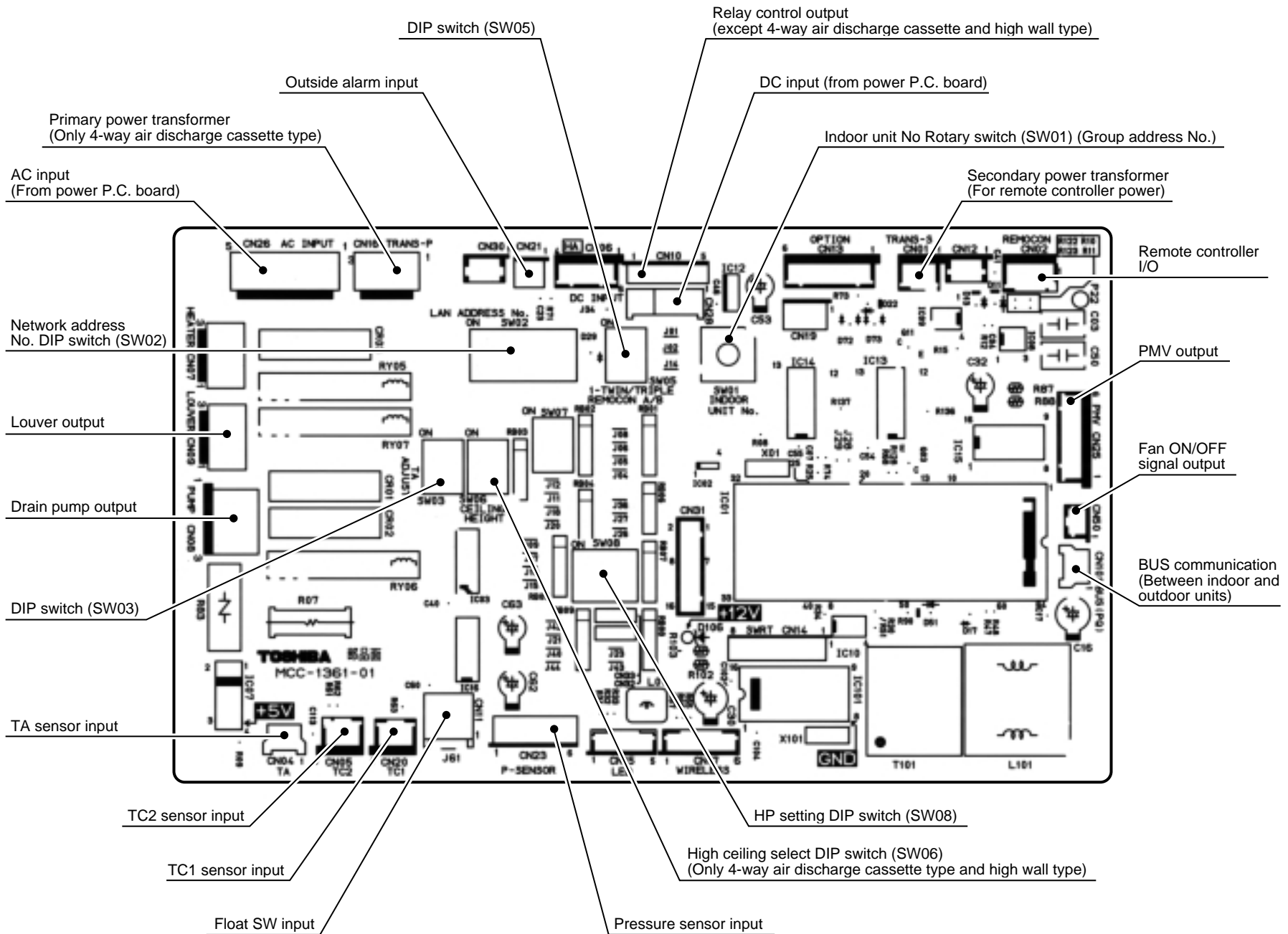

3-7-2-2. 4-way Air Discharge Cassette Type

■ MCC-1382 (Power/Motor P.C. board)

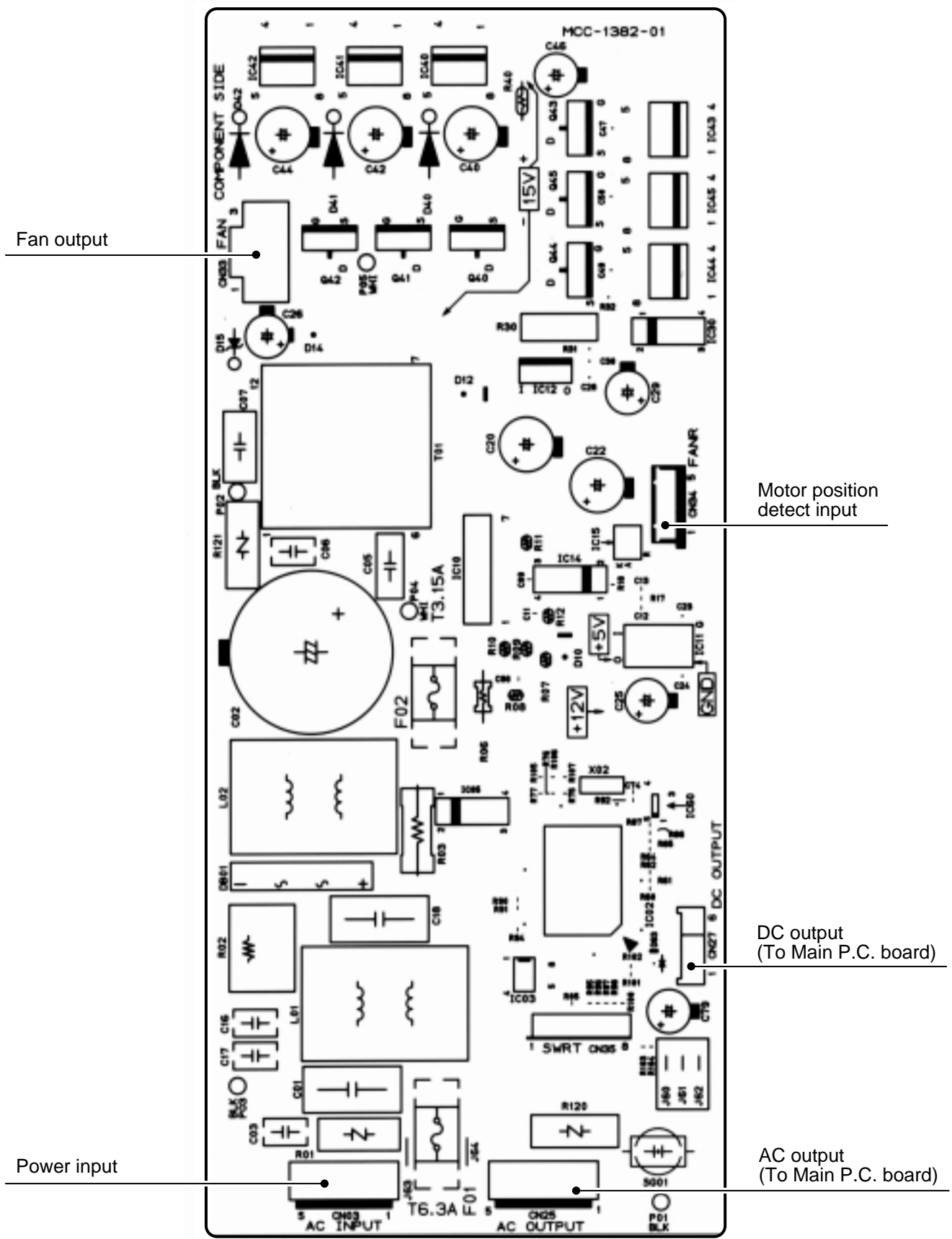

3-7-2-3. 1-way Air Discharge Cassette, Concealed Duct Type

■ MCC-1355 (Power/Motor P.C. board)

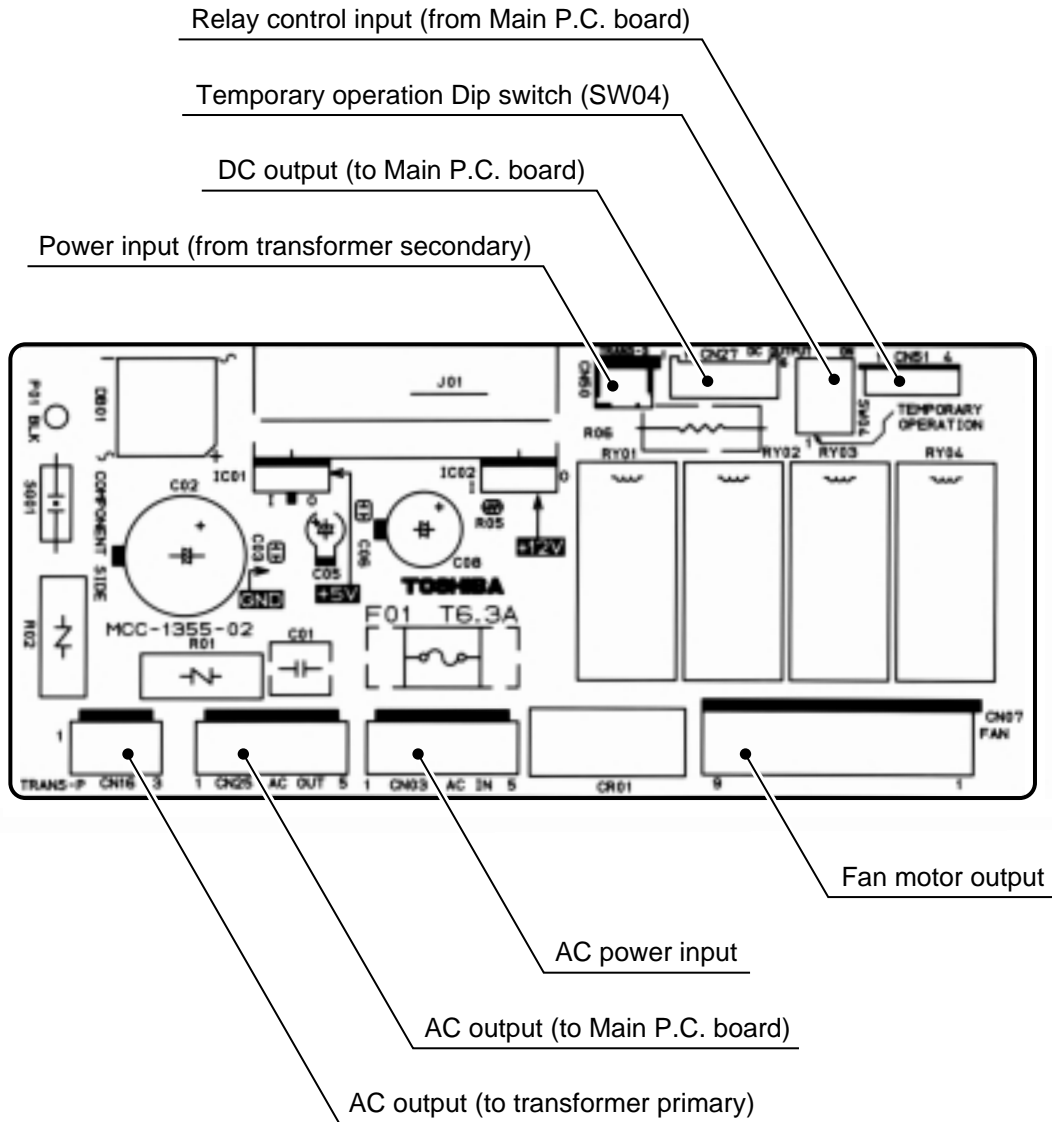

3-7-2-4. High Wall Type

■ MCC-1365 (Power/Motor P.C. board)

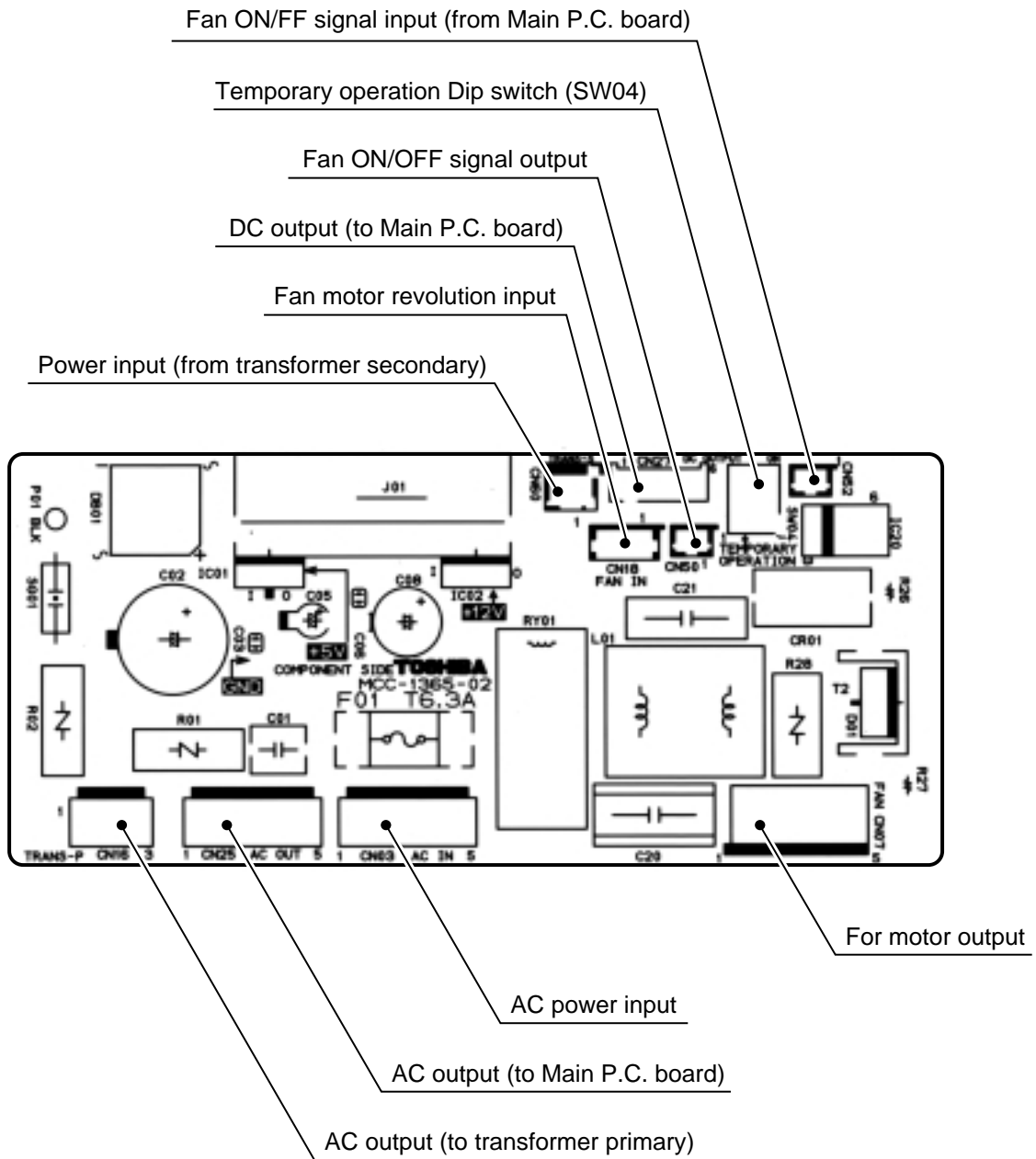

[4-way air discharge cassette type]

Service P.C. board selection corresponded table (Main P.C. board MCC-1361)

The indoor control P.C. board (MCC-1361) can correspond to multiple models. When replacing P.C. board assembly, set the DIP switch, rotary switch, and jumper(s) according to the following description.

Switch set up

- 1 **SW01** Indoor unit No. : Match to No. which the rotary switch is set up.
 : Master unit 1
 : Server units 2 to 16
- 2 **SW02** Network address : Match to set up contents of P.C. board before replacement.
- 3 **SW03** : Match to set up contents of P.C. board before replacement.
- 4 **SW05** (Bit 1) : Match to set up contents of P.C. board before replacement.
- 5 **SW05** (Bit 2) : Set to OFF side.
- 6 **SW06** : Match to set up contents of P.C. board before replacement.
- 7 **SW07** : Match to set up contents of P.C. board before replacement.
- 8 **SW08** Horse power set up : Match to set up contents of P.C. board before replacement.

Jumper set up

- 1 Match to the set up contents of P.C. board before replacement except for J15, J16 and J17.
- 2. **J15, J16, J17** : For the following models, set up the jumper(s) according to the table.

O : Provided (Original), X : None (cut)

Model name MMU- Part No.	P0121H	P0151H P0181H	P0241H	P0301H	P0361H	P0481H	Status at shipment from factory
J15	O	X	O	X	O	X	O
J16	X	O	O	X	X	O	O
J17	X	X	X	O	O	O	O

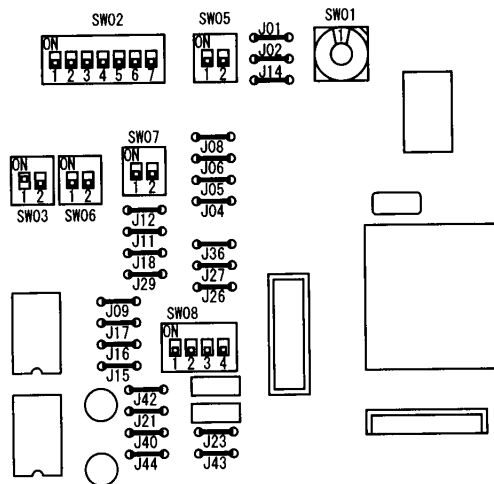

Service P.C. board part name : <MCC-1361>

CM02C04S

[Concealed duct, 1-way air discharge cassette type]

Service P.C. board selection corresponded table (Main P.C. board MCC-1361)

The indoor control P.C. board (MCC-1361) can correspond to multiple models. When replacing P.C. board assembly, set the DIP switch, rotary switch, and jumper(s) according to the following description.

Switch set up

- 1 **SW01** Indoor unit No. : Match to No. which the rotary switch is set up.
 : Master unit 1
 : Server units 2 to 16
- 2 **SW02** Network address : Match to set up contents of P.C. board before replacement.
- 3 **SW03** : Match to set up contents of P.C. board before replacement.
- 4 **SW05** (Bit 1) : Match to set up contents of P.C. board before replacement.
- 5 **SW05** (Bit 2) : Set to OFF side.
- 6 **SW06** : Match to set up contents of P.C. board before replacement.
- 7 **SW07** : Match to set up contents of P.C. board before replacement.
- 8 **SW08** Horse power set up : Match to set up contents of P.C. board before replacement.

Jumper set up

- 1 Match to the set up contents of P.C. board before replacement except for J11, J12 and J20.
- 2. **J20** : If Auto-turn-louver is equipped, cut J20.
- 3. **J11, J12** : See the P.C. board before replacement, according to the table below, cut jumper(s) if necessary.

O : Provided, X : None (cut)

Before replacement		Service P.C. board setting		
J11	J12	J11	J12	Applicable models
O	O	X	O	1-way air discharge cassette type Concealed duct type
X	O	X	O	All models
O	X	O	X	All models
X	X	X	X	All models

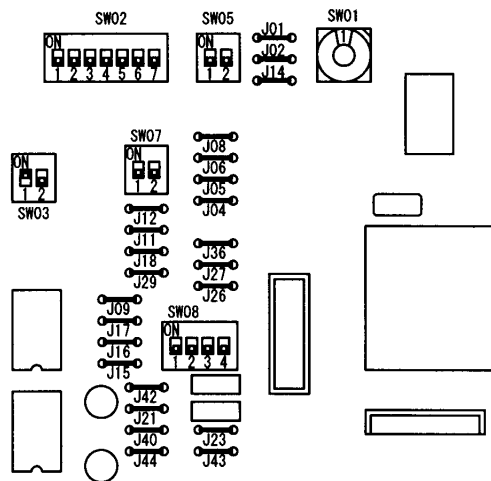

Service P.C. board part name : <MCC-1361>

CM02C06S

[High wall type]

Service P.C. board selection corresponded table (Main P.C. board MCC-1361)

The indoor control P.C. board (MCC-1361) can correspond to multiple models. When replacing P.C. board assembly, set the DIP switch, rotary switch, and jumper(s) according to the following description.

Switch set up

- 1 **SW01** Indoor unit No. : Match to No. which the rotary switch is set up.
 : Master unit 1
 : Server units 2 to 16
- 2 **SW02** Network address : Match to set up contents of P.C. board before replacement.
- 3 **SW03** : Match to set up contents of P.C. board before replacement.
- 4 **SW05** (Bit 1) : Match to set up contents of P.C. board before replacement.
- 5 **SW05** (Bit 2) : Set to OFF side.
- 6 **SW06** : Match to set up contents of P.C. board before replacement.
- 7 **SW07** : Match to set up contents of P.C. board before replacement.
- 8 **SW08** Horse power set up : Match to set up contents of P.C. board before replacement.

Jumper set up

- 1 Match to the set up contents of P.C. board before replacement except for J15, J16 and J17.
- 2. **J15, J16, J17** : For the following models, set up the jumper(s) according to the table.

O : Provided (Original), X : None (cut)

Model name MMK- Part No.	P0091H	P0121H	P0151H	P0181H	P0241H	Status at shipment from factory
J15	O		X		O	O
J16	X		O		O	O
J17	O		O		O	O

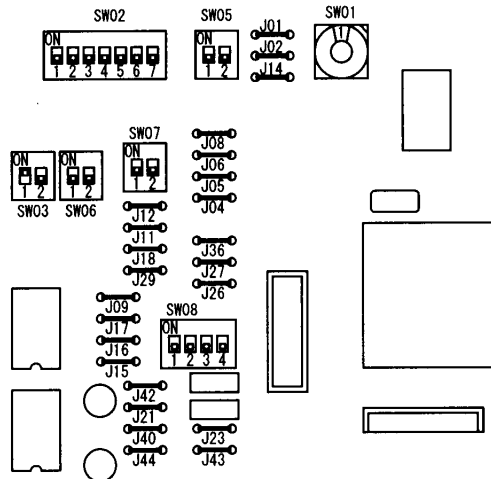

Service P.C. board part name : <MCC-1361>

CM02C05S

Service indoor motor P.C. board selection corresponded table (MCC-1382)

The indoor motor P.C. board (MCC-1382) can correspond to multiple models. When replacing P.C. board assembly, set the jumper according to the following table.

○ : Provided (Original), X : None (cut)

Model name MMU- Part No.	P0121H	P0151H	P0181H	P0241H	P0301H	P0361H	P0481H	Status at shipment from factory
J60			○				○	○
J61			○				X	○
J62			X				○	○

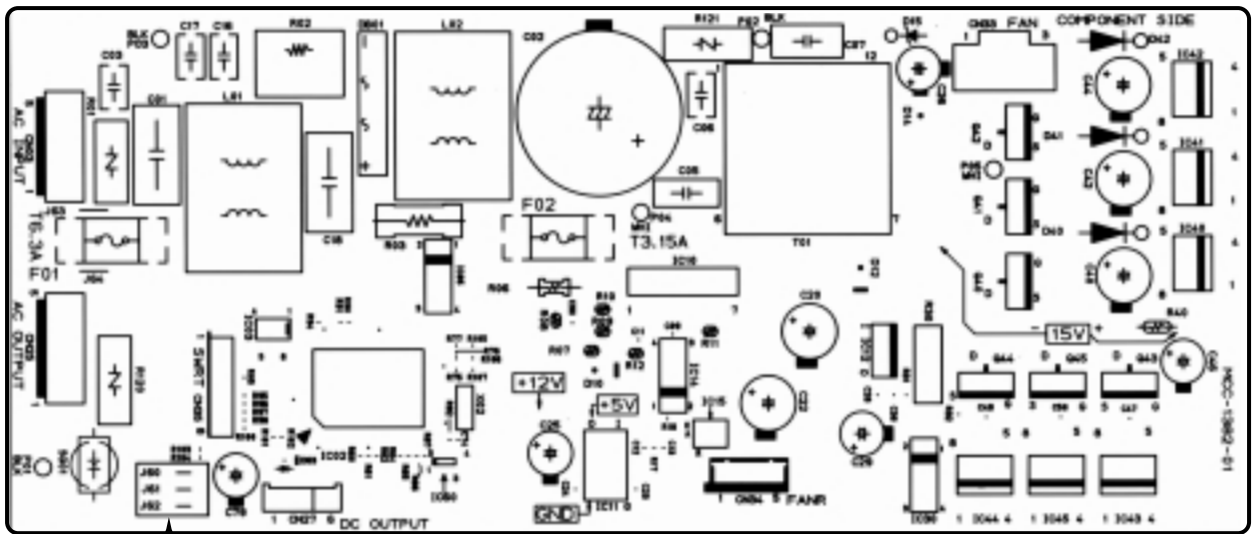

Jumper cable

Service P.C. board part name : <MCC-1382>

CM02C01S

3-7-3. Outdoor Unit

3-7-3-1. Modular Multi control block diagram (Cooling only model) MMY-MP10018, MP08018, MP06018

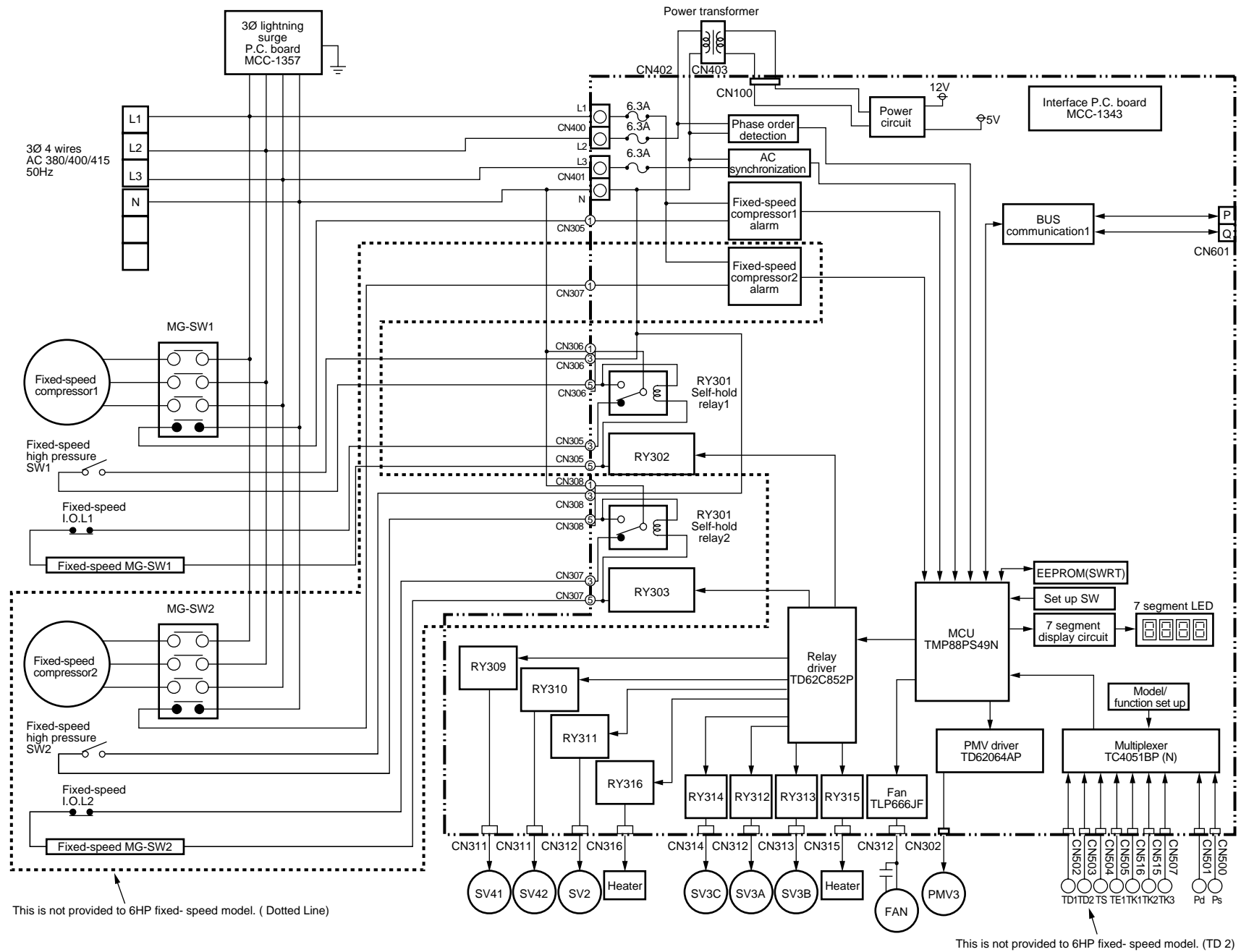

3-7-3-2. Modular Multi control block diagram (Cooling only model)
MMY-MP1001T8, MP0801T8

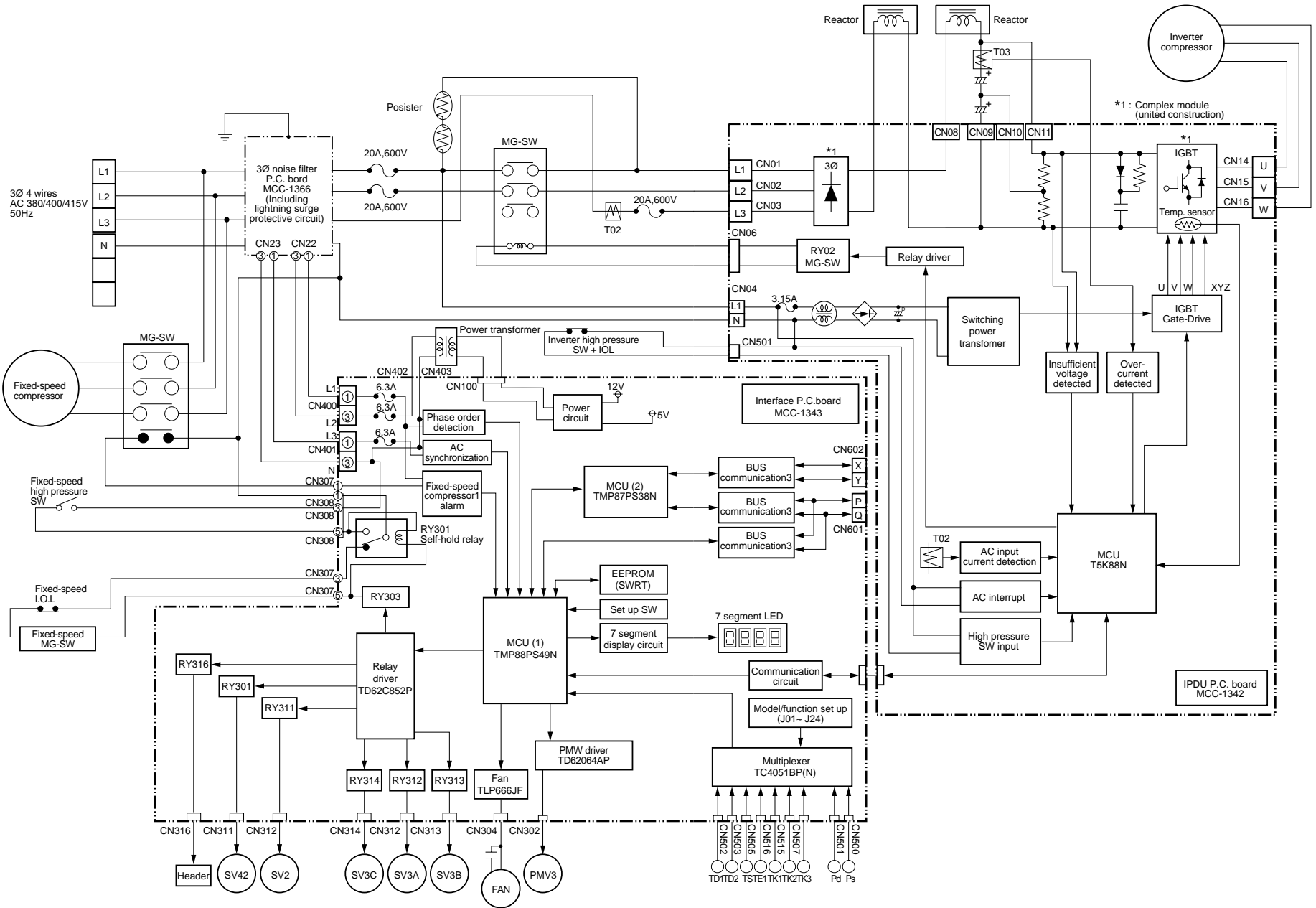

3-7-3-3. Modular Multi control block diagram (Heat pump model : Fixed-speed unit)

MMY-MP1001H8, MP0801H8, MP0601H8
MMY-MP1001H7, MP0801H7, MP0601H7

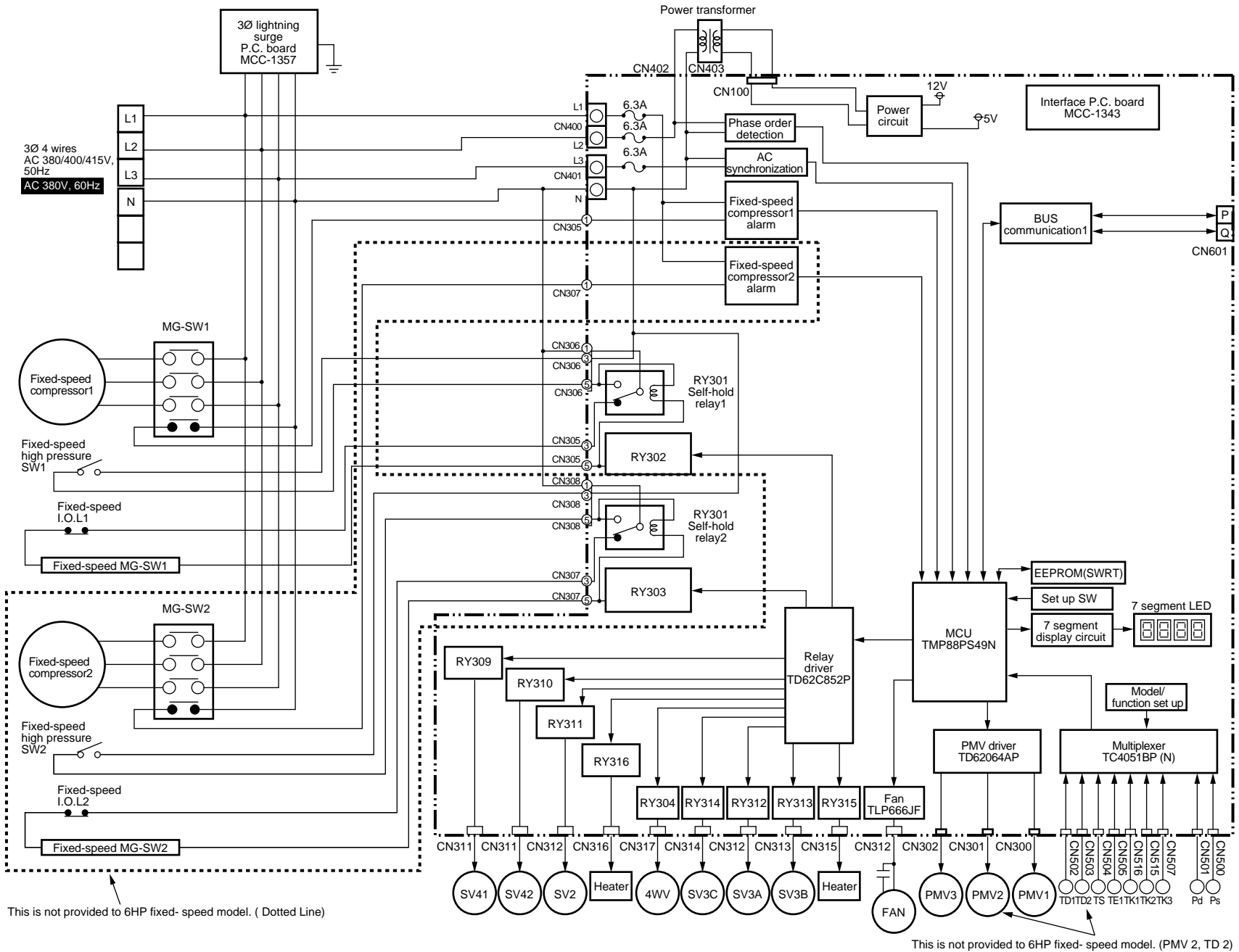

3-125

3-7-3-4. Modular Multi control block diagram (Heat pump model : Inverter unit)

MMY-MP1001HT8, MP0801HT8
MMY-MP1001HT7, MP0801HT7

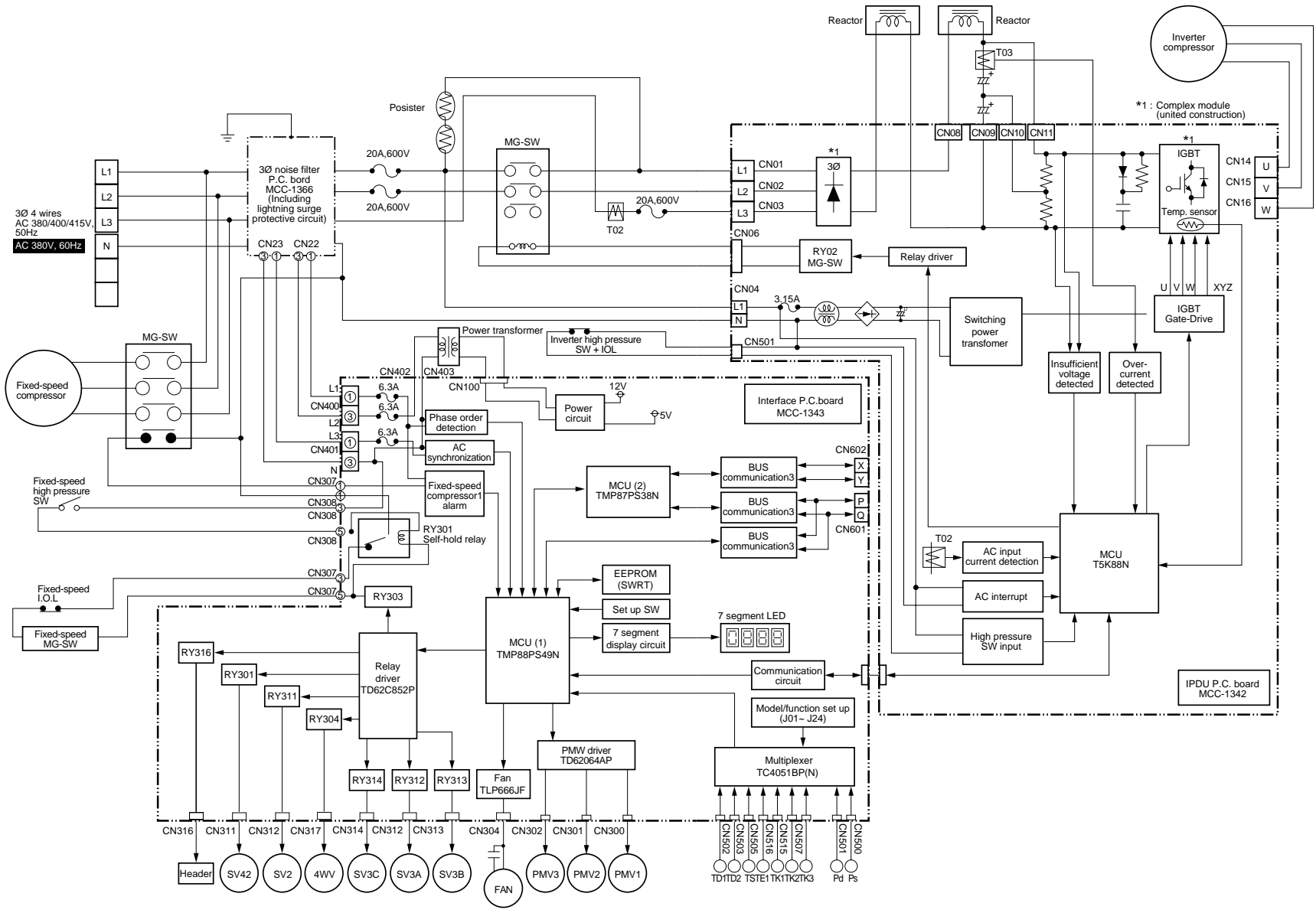

3-7-3-5. Interface P.C. board check positions (MCC-1343)

(* : They are used in the Heat Pump model only.)

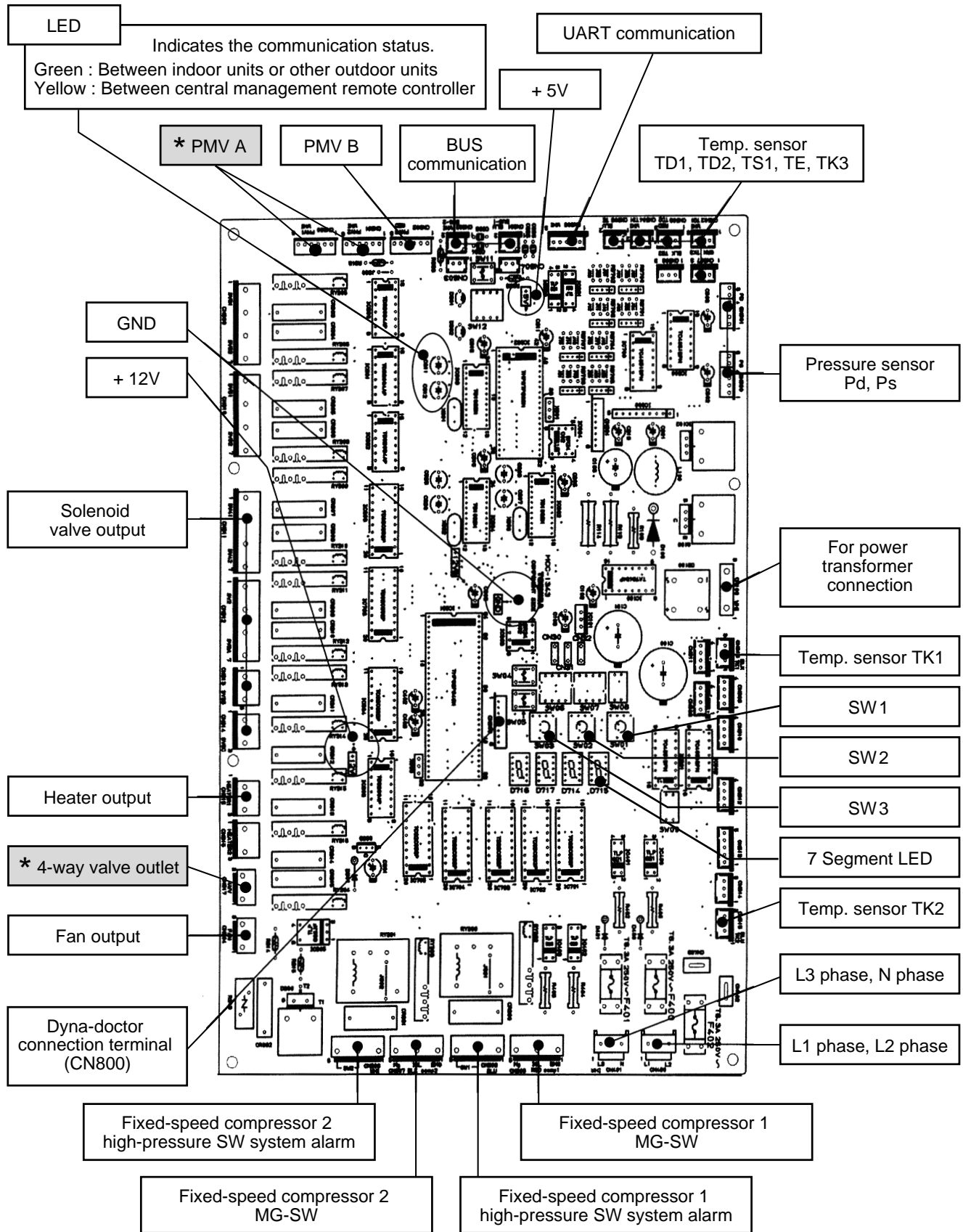

3-7-3-6. IPDU P.C. board check positions (MCC-1342)

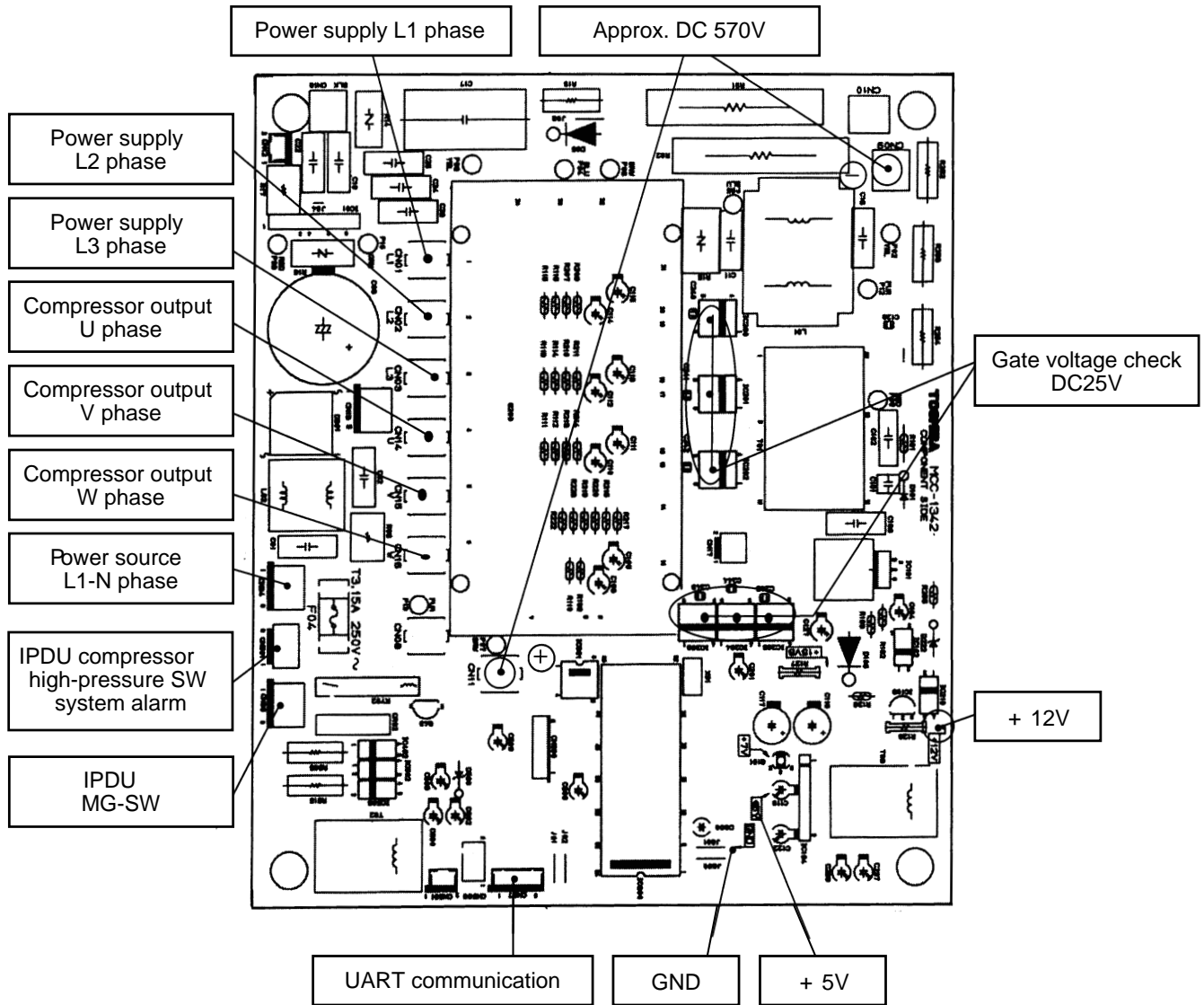

3-7-3-7. Method of how to change interface control P.C. board

SN 4316V105

SN 4316V106

This service P.C. board is common to all models.
Change the P.C. board according to the following method.

Method

- (1) Turn off the power supply of the outdoor control unit.
- (2) Pinch off all connectors and faston terminals connected to the interface P.C. board.
(Pinch off the connector without grasping the leads.)
- (3) Remove the interface P.C. board from the seven supporters.
- (4) Cut the jumper(s) of the P.C. board according to the below table.
- (5) Set the P.C. board in the outdoor control unit after setting the jumper(s). (Make sure the P.C. board is inserted surely in the supporters.)
- (6) Insert the connectors and the faston terminals.
(Confirm there is no mis-insertion.)
- (7) If parts on the P.C. board bend by the P.C. board exchange. Correct them and make sure they don't come in contact with other parts.
- (8) After putting a cover on the outdoor units, turn on the power supply and confirm the operating.

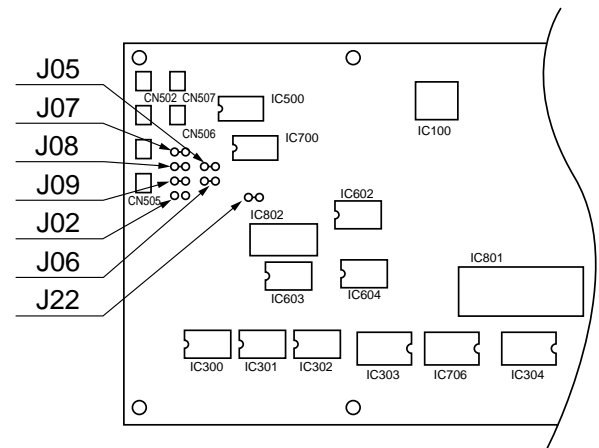

Inverter model

SN 4316V105

No.	Model	J02	J05	J06	J07	J08	J09	J22	P.C. board
1	MMY-M1001T8	—	—	—	—	—	—	Cut	MMY-INV
2	MMY-M0801T8	—	—	—	Cut	Cut	—	Cut	MMY-INV
3	MMY-M1001HT8	—	—	—	—	—	—	—	MMY-INV
4	MMY-M0801HT8	—	—	—	Cut	Cut	—	—	MMY-INV
5	MMY-MP1001HT8 MMY-MP1001HT7	Cut	—	—	—	—	—	—	MMY-INV
6	MMY-MP0801HT8 MMY-MP0801HT7	Cut	—	—	Cut	Cut	Cut	—	MMY-INV
7	MMY-MP1001T8	Cut	—	—	—	—	—	Cut	MMY-INV
8	MMY-MP0801T8	Cut	—	—	Cut	Cut	Cut	Cut	MMY-INV

Fixed-speed unit model

SN 4316V106

No.	Model	J02	J05	J06	J07	J08	J09	J22	P.C. board
1	MMY-M10018	—	Cut	—	—	—	—	Cut	MMY-E-P
2	MMY-M08018	—	Cut	—	Cut	Cut	—	Cut	MMY-E-P
3	MMY-M06018	—	Cut	Cut	Cut	—	Cut	Cut	MMY-E-P
4	MMY-M1001H8	—	Cut	—	—	—	—	—	MMY-E-P
5	MMY-M0801H8	—	Cut	—	Cut	Cut	—	—	MMY-E-P
6	MMY-M0601H8	—	Cut	Cut	Cut	—	Cut	—	MMY-E-P
7	MMY-MP1001H8 MMY-MP1001H7	Cut	Cut	—	—	—	—	—	MMY-E-P
8	MMY-MP0801H8 MMY-MP0801H7	Cut	Cut	—	Cut	Cut	—	—	MMY-E-P
9	MMY-MP0601H8 MMY-MP0601H7	Cut	Cut	Cut	Cut	—	Cut	—	MMY-E-P
10	MMY-MP10018	Cut	Cut	—	—	—	—	Cut	MMY-E-P
11	MMY-MP08018	Cut	Cut	—	Cut	Cut	—	Cut	MMY-E-P
12	MMY-MP06018	Cut	Cut	Cut	Cut	—	Cut	Cut	MMY-E-P

3-7-3-8. How to replace IPDU P.C. board

IPDU P.C. board

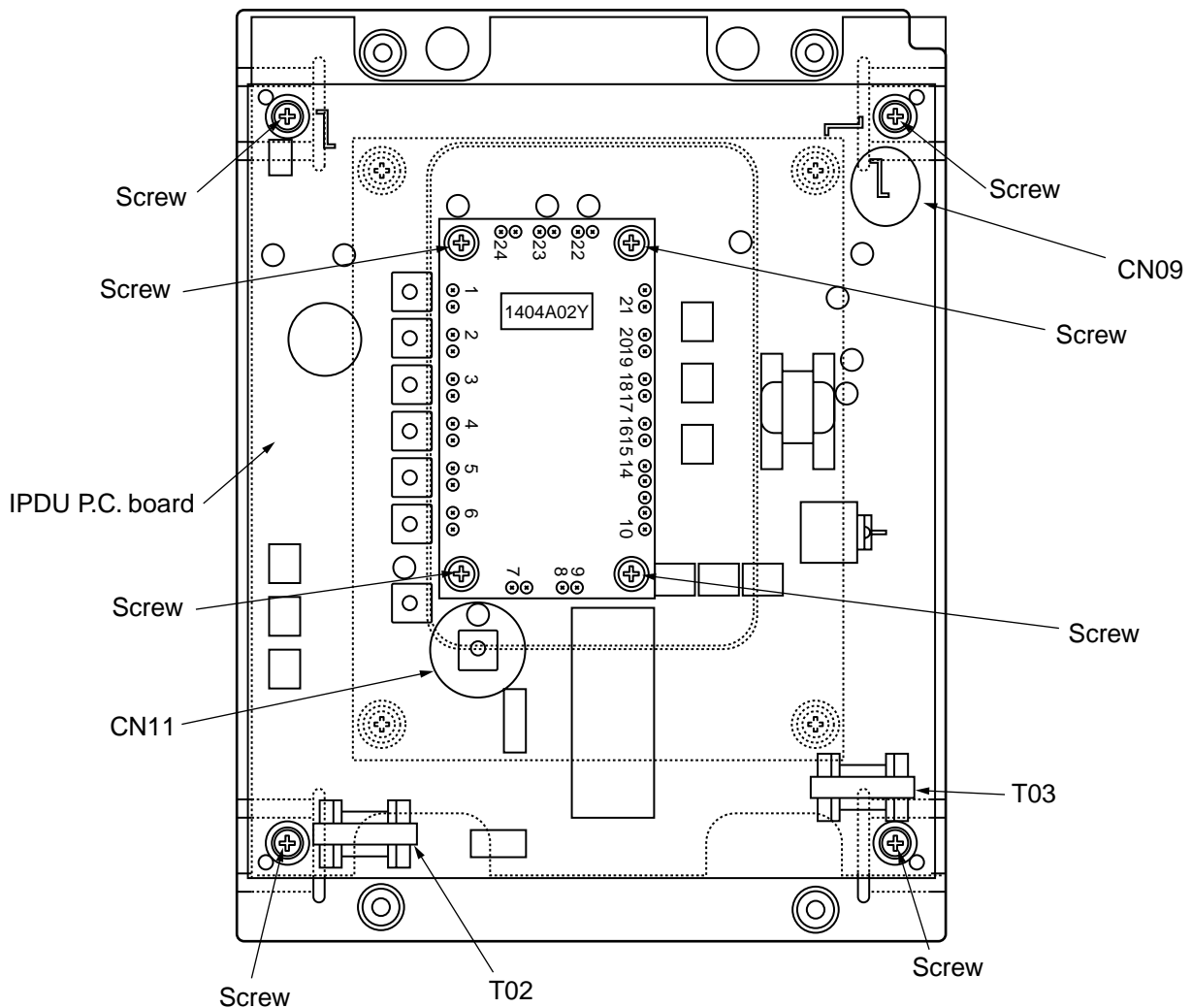

■ Procedure

- (1) Be sure to turn off power supply of the outdoor unit before replacement work.
- (2) Wait for 10 minutes or more after turning off power supply, measure to check the voltage between CN09 and CN11 on IPDU P.C. board is 10V or less and then replace IPDU P.C. board.
- (3) Remove all the connectors, faston terminals, and lead wires connected to IPDU P.C. board.
- (4) Remove all screws at the four corners of IPDU P.C. board and four screws fixing the multi modules, which are shown in the figure.
- (5) After removing IPDU P.C. board, remove the supporters attached at the four corners of IPDU P.C. board and reattach them to IPDU service P.C. board.
- (6) Apply silicon grease to radiation surface of the multi module (surface which comes in contact with heat sink) on IPDU service P.C. board.
- (7) Install IPDU service P.C. board to the controller, and fix it with eight screws.
- (8) According to the wiring diagram, connect connectors, faston terminals, and lead wires to IPDU service P.C. board. In this time, do not forget to pass the lead wires through T02 and T03 on IPDU service P.C. board.
- (9) Cover the outdoor unit, and check the operation by turning on power supply.

3-8. EMERGENCY OPERATION

3-8-1. Emergency Operation in Failure of Pressure Sensor or Temperature Sensor

This air conditioner does not correspond to the backup operation function when each sensor has failed. When a fault is judged as one of sensors, use "Emergency operation when outdoor unit" has failed.

3-8-2. Emergency Operation When One Compressor has Failed (Emergency Operation in Compressor Trouble)

<Outline>

When one of two compressors installed to the outdoor unit fails, take the following action if emergency operation by other normal compressor is necessary.

- * **NOTE 1** : In the case of single compressor installed unit (6HP), backup operation by one compressor is unavailable. In this time, use "Emergency operation when outdoor unit failed".
- * **NOTE 2** : For the emergency operation when the failed compressor is an inverter, the capacity control is performed by ON/OFF control of fixed-speed compressor.
- * **NOTE 3** : When motor winding of the compressor fails (Short, etc.), do not set backup of the compressor because deterioration of oil is great.
(Another error on the outdoor unit may be caused.)

<Work procedure>

- (1) First, turn off the power supply of all the outdoor units which are connected to the system.
- (2) The following works are performed to the outdoor unit of which the compressor failed.
According to the following table, set DIP switch (SW06) on the interface P.C. board.

<Table Switch set up in compressor backup>

	SW06			
	Bit 1	Bit 2	Bit 3	Bit 4
Initial set up at shipment from factory	OFF	OFF	OFF	OFF
No.1 compressor (Compressor at left of front side) has failed	ON	OFF	OFF	OFF
No.2 compressor (Compressor at right of front side) has failed	OFF	ON	OFF	OFF

- (3) Then, backup set up is complete. Turn on the power supply of all the outdoor units.

3-8-3. Emergency Operation When Outdoor Unit has Failed

In this air conditioner, backup operation can be set up to both inverter unit and fixed-speed unit when outdoor unit has failed.

In a system in which two or more outdoor units are connected, perform the emergency operation for failure of outdoor unit when alarm mode such as the following cases occurs.

- (1) Fault of compressor (Short or when one compressor is not operating)
- (2) Fault of pressure sensor (Pd, Ps)/fault of temp. sensor (TD1, TD2, TS, TE, TK1, TK2, TK3)
- (3) Fault of refrigerating cycle parts, fan system parts, interface P.C. board, IPDU P.C. board, electric part system, etc.

*** NOTE :** Perform emergency operation for only one unit in 1 system.

3-8-3-1. Fault in fixed-speed unit (Setup of emergency operation for terminal outdoor unit)

<Outline>

When a fixed-speed unit connected to the system fails, perform emergency process according to the following work procedure firstly, and then perform emergency operation by the inverter unit and other fixed-speed units.

<Work procedure>

- (1) First, turn off the power supply of all the outdoor units which are connected to the system.
- (2) The following works are performed to the failed fixed-speed unit.
 - 1) Close service valve of gas pipe fully. (Fully close by turning clockwise)
 - 2) If refrigerant leakage (Not closed) occurs on even one of PMV A*, PMV B close service valve of the liquid pipes. (* : It is not provided in the cooling only model.)
(Fully close by complete turning clockwise)
 - 3) Check service valve of the balancing pipe is open fully. (Fully open by turning counterclockwise)
 - 4) [In case of fault of compressor/fault of electric part system]
 - a. Works to the failed fixed-speed unit are complete.
 - b. Then, keep the power supply OFF.
 - 5) [In case of fault of other cycle part system]
 - a. Remove BUS-1 communication connector (BLU)[CN601] on the interface P.C. board.
 - b. Works to the failed fixed-speed unit are complete.
 - c. Then, turn on the power supply to protect the compressor. (Turn on crank case heater.)
- (3) Perform the following works for the inverter unit.
 - 1) Set DIP SW 07/Bit 3 on the interface P.C. board to ON. (Set up to correct oil recovery capacity)
 - 2) Set DIP SW 09/Bit 2 on the interface P.C. board to ON. (Set up to not to detect indoor over capacity)
 - 3) Turn on the power supply of each outdoor unit.
 - 4) Set operation permission of outdoor unit backup operation. (Alarm clear set up)
 - a. Set rotary switches on the interface P.C. board, SW03 to [No.1]/SW02 to [No.1]/SW01 to [No.1].
 - b. After [U.] [1] [8] [d] were displayed on the 7 segment LED of the interface P.C. board, set SW03 to [No.1]/SW02 to [No.16]/SW01 to [No.2].
 - c. After [E.] [r] [] [] are displayed on the 7 segment LED of the interface P.C. board, keep push-switch SW04 pushed for 5 seconds or more.
[E.] [r] [C] [L] are displayed on the 7 segment LED for 5 seconds, and work is complete.
 - d. Set SW03 to [No.1]/SW02 to [No.1]/SW01 to [No.1].
If [U.] [1] [] [] are displayed on the 7 segment LED, it is normal.
- (4) Then, emergency process is complete. The operation then starts by a command from the indoor unit.

3-8-3-2. Fault of inverter unit (Setup of emergency operation for center outdoor unit)

<Outline>

When an inverter unit fails, perform emergency process according to the following work procedure firstly, and then perform emergency operation by other fixed-speed unit only.

<Work procedure>

- (1) First, turn off the power supply of all the outdoor units which are connected to the system.
- (2) The following works are performed to the failed inverter unit.
 - 1) Close service valve of gas pipe fully. (Fully close by turning clockwise)
 - 2) If refrigerant leakage (Not closed) occurs on even one of PMV A*, PMV B close the service valve of the liquid pipe fully. (Fully close by turning clockwise) (* : It is not provided in the cooling only model.)
 - 3) Check service valve of the balancing pipe is opened fully.
(Fully open by turning counterclockwise)
 - 4) Remove <Short-circuit connector> connected to [CN604] on the interface P.C. board. The removed <Short-circuit connector> is used for the fixed-speed unit. (Described in item (4) below.)
 - 5) [In case of fault of compressor/fault of electric part system]
 - a. Works to the failed inverter unit is complete.
 - b. Then, keep the power supply OFF.
 - c. When central management remote controller is connected to the inverter unit, the central management remote controller cannot be used.
 - 6) [In case of fault of other cycle part system]
 - a. Set DIP SW06/Bit 1, 2, 3, 4 on the interface P.C. board to ON. (LED display changes to )
 - b. Works to the failed inverter unit is complete.
 - c. Then, turn on the power supply to protect the compressor. (Turn on winding heater)
 - d. The central management remote controller is used normally.
- (3) Select a master outdoor unit among the fixed-speed units according to the following reference.
 - 1) When only one fixed-speed unit is connected, select it as the master outdoor unit.
 - 2) When two or more fixed-speed units are connected, select one connected to the nearest position of the inverter unit as the master outdoor unit.
- (4) Perform the following works for the fixed-speed unit selected as the master outdoor unit.
 - 1) Insert <Short-circuit connector> into [CN604] on the interface P.C. board.
(One removed from the inverter unit)
 - 2) Set DIP SW07/Bit 3 on the interface P.C. board to ON. (Set up to correct oil recovery capacity)
 - 3) Set DIP SW08/Bit 2 on the interface P.C. board to ON. (Set up to select center outdoor unit)
 - 4) Set DIP SW09/Bit 2 on the interface P.C. board to ON. (Set up not to detect indoor over capacity)
- (5) Turn on the power supply of each outdoor unit.
- (6) Emergency process is complete. The operation then starts by a command from the indoor unit.

3-8-3-3. Outdoor emergency operation in cooling season (Simple setting method)

<Outline>

When either inverter unit or fixed-speed unit fails during cold season, this function is used to omit various set up and perform emergency operation quickly.

For cases except those corresponded to cooling operation only, the operation is same as the previously mentioned "Emergency operation when outdoor unit has failed".

*** NOTE 1 :** In this setting, heating operation cannot be performed. When receiving a heating command from the indoor unit, the check code [8C] is displayed and the protective stop status is kept.
(If heating operation is incorrectly performed, the air conditioner is not damaged.)

*** NOTE 2 :** If a trouble occurred on the interface or electric circuit system, an emergency operation cannot be performed by this setting. In this case, execute the previously mentioned "Emergency operation when outdoor unit has failed".

<Work procedure>

- (1) First, turn off the power supply of all the outdoor units which are connected to the system.
- (2) The following works are performed to the failed outdoor unit. (Even if the failed outdoor unit is the inverter unit or fixed-speed unit, the following works are common specifications.)
 - 1) Set DIP SW06/Bit 1 and Bit 2 on the interface P.C. board to ON.
 - 2) If refrigerant leakage (Not closed) occurs on even one of PMV A*, PMV B close the service valve of the liquid pipe fully. (Fully close by turning clockwise) (* : It is not provided in the cooling only model.)
- (3) Turn on power supply of each outdoor unit.
If the fault is a compressor insulation error, etc., disconnect the lead wire of the compressor previously before work.
- (4) Emergency process is complete. The cooling operation then starts by a command from the indoor unit.

3-8-3-4. Automatic backup operation in sensor error of indoor unit

If a sensor used for the indoor unit has failed with a pattern in the following table, the unit starts a backup operation automatically while displaying the check code. During backup operation, unevenness of capacity generates because the capacity correction control is not performed.

Accordingly, replace the sensor with error immediately. When a sensor has failed with other pattern than those in the following table, TC1 + pressure, TC2 + pressure, TC1 + TC2 + TA, etc. for example, the corresponding indoor unit only stops because there is problem on reliability. (Thermostat OFF)

NOTE :

Never perform backup operation in the outdoor unit during backup operation in the indoor unit because the compressor may be damaged.

Defective sensor	Measures	Check code
TC2	Automatic backup operation	94
Pressure	Automatic backup operation	b9
TA	Automatic backup operation	0C
TC1	Automatic backup operation	93
TC2 + TA	Automatic backup operation	94, 0C
Pressure + TA	Automatic backup operation	b9, 0C
TC1 + TA	Automatic backup operation	93, 0C

3-9. FORCED FUNCTION OF OIL LEVEL DETECTION (OUTDOOR UNIT)

The oil level detection control can be forcibly implemented by a switch on the interface P.C. board of the outdoor unit. When an error in the oil tank circuit occurs and there is no cause such as sensor error, connection error, out of place, valve close operation error, etc., check as follows.

<Oil tank circuit system error>

Check code	Check code name	Judgment
d7	Low oil level detection protection	Oil level shortage status has been detected continuously for approx. 2 hours while oil equalizing control was continuously implemented.
d8	TK1 temp. detection circuit alarm	Temp. change at the oil tank primary side was not detected while oil level detection control was implemented.
d9	TK2 temp. detection circuit alarm	Temp. change at the oil tank secondary side was not detected while oil level detection control was implemented.
db	Oil level detection circuit blockage detection	Temp. change at both the oil tank primary side and secondary side was not detected while oil level detection control was implemented.
dC	Oil level detection circuit leakage detection	The status that TK1 temp. is high (50°C or more) was continuously detected for a long time.

<Operation procedure>

- 1) Start the trial operation after alarm was cleared.
- 2) Set SW01/SW02/SW03 on the interface P.C. board of the outdoor unit to 1/16/1, which oil level is to be detected.
- 3) Push the push-switch SW04 for 2 seconds.
- 4) Check the 7 segment display on the P.C. board.

	7 segment display
Operation starts. →	[OL] [- -]
During operation. →	Counted down every 10 seconds from [OL] [1F]
Oil level detection control starts. →	[OL] [FF]
During oil level detection counting. →	Counted up every 1 second from [OL] [01]
Oil level judgment result.	[OL] [A0] [A1] [A2] [A3] [A4]

<Oil level judgment result>

Judgment	Judgment
[A0]	Oil amount in the compressor is adequate. Check that the operation continues and there is no problem. If [dC] occurred, execute check even if oil level was judged as adequate.
[A1]	Oil level was judged as shortage. If this judgment continues, the system stops in protection. When [d7], [dC] occurred, check according to the check items.
[A2]	TK1 temp. detection was judged as an error. If this judgment continues, the system stops in protection. When [d8] occurred, check according to the check items.
[A3]	Oil level detection circuit (SV3C valve) was judged as blockage. If this judgment continues, the system stops in protection. When [db] occurred, check according to the check items.
[A4]	TK2 temp. detection was judged as an error. If this judgment continues, the system stops in protection. When [d9] occurred, check according to the check items.

<Peripheral circuits of oil tank>

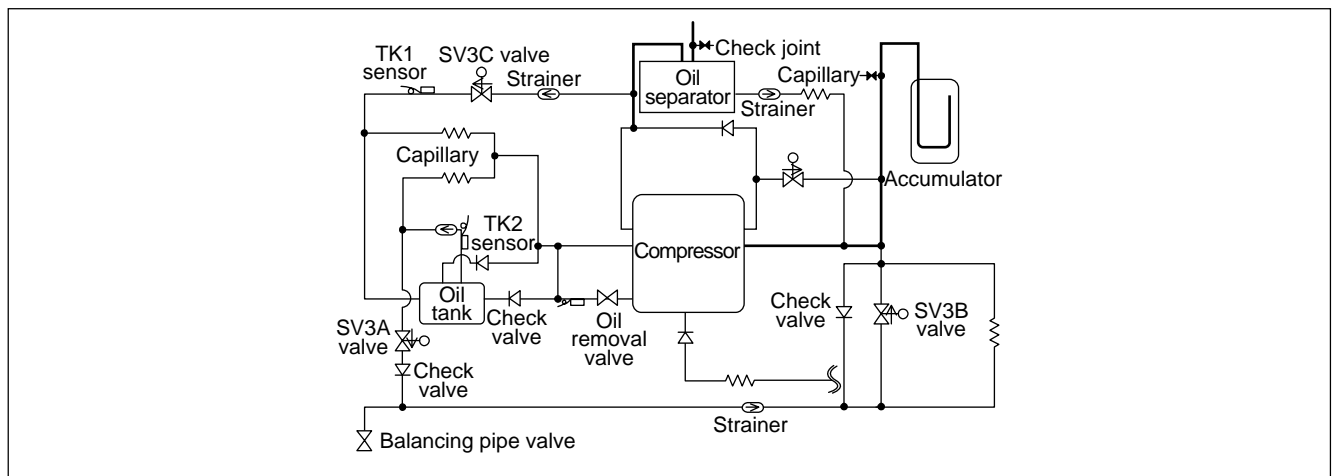

3-10. REFRIGERANT RECOVERY METHOD WHEN REPLACING THE COMPRESSOR

3-10-1. Refrigerant Recovery Method in the Failed Outdoor Unit

A reclaim function is provided to this A/C. When multiple outdoor units are connected in the system, the refrigerant can be recovered from the outdoor unit to be repaired by performing the reclaim operation in a normal outdoor unit.

- * **NOTE 1** : In reclaim function, the refrigerant recovery ratio changes according to the outside temp., etc.
After reclaim operation, recover the remained gas using a recovery device, etc., and be sure to measure the recovered refrigerant amount. (When operating the reclaim heating the accumulator of the outdoor unit to be repaired, the recovery ratio of refrigerant increases.)
- * **NOTE 2** : After this is complete, the system cannot be operated until the failed outdoor unit has been completely repaired. (Continuous operation is unavailable because of refrigerant over-charge operation.)
- * **NOTE 3** : While FULL CLOSE alarm (valve cannot be opened) of PMV A* and PMV B is output, the reclaim work is not performed because refrigerant in the liquid tank cannot be recovered. In this case, recover all refrigerant in the system using a recovery device, etc.
(* : It is not provided in the cooling only model.)

<Work procedure (A)>

For the positions of “Liquid pipe service valve”, “Gas pipe service valve”, and “Balancing pipe service valve” described in the explanation of the work procedure, refer to the layout diagram in P.150.

[In case that backup operation is not executed for fault of outdoor unit.]

A-1) Turn on the power supply of all the outdoor units, and keep the system in stop status (Indoor unit stop).

If insulation of the compressor is insufficient, remove lead wire of the compressor before turning on the power supply.

A-2) For the failed outdoor unit, execute the following operations.

- 1) Close fully the liquid service valve onlye.
(Keep the service valves of gas pipe and balancing pipe opened fully.)
- 2) Set the rotary switches on the interface P.C. board to the following numbers.
 - SW03 [No.1]/SW02 [No.11]/SW01 [No.2]
 - 7 segment display : [r].[d][][]
- 3) Keep pushing the push-switch SW04 on the interface P.C. board for 5 seconds or more.
Start the following operations.
 - * When interrupting the work, turn off the power supply of all the outdoor units or push the push-switch SW05 on the interface P.C. board.
 - a. 7 segment display : [r].[d][1][1][]
 - b. Operate the outdoor fan.
 - c. PMV A*, PMV B open. (* : It is not provided in the cooling only model.)
 - d. Solenoid valves SV3A, SV3B, and SV3C are turned on.
 - e. Other outdoor units start automatic operation in trial cooling mode.
(It may take a little time to activate the compressor.)
- 4) Push the push-switch SW04 on the interface P.C. board for approx. 2 seconds.
The present refrigerant pressure data (MPa) is displayed.
 - 7 segment display : [H][*].[*][*][*] (* : Value of Pd pressure sensor)
 - * Every push of the push-switch SW04 the display changes.

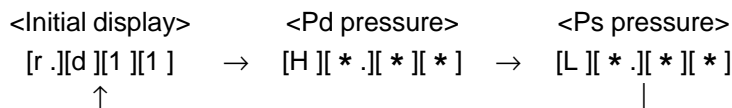

A-3) 10 minutes after the system had been activated, close the gas pipe service valve of the failed outdoor unit fully.

A-4) For the outdoor unit operating in reclaim mode, execute the following operations.

- 1) Select an outdoor unit having the lowest unit No. (Usually, inverter unit) as “Outdoor unit to adjust pressure”.
- 2) Close fully service valves of the balancing pipes on the other outdoor units than the outdoor unit to adjust pressure and the failed outdoor unit.

* **NOTE** : Open service valves of the balancing pipe of outdoor unit selected for pressure adjustment and the failed outdoor unit fully.

*** Outdoor unit No.**

When SW01, SW02, and SW03 are set to [No.1], No. displayed on 7 segment is the outdoor unit No. (Ex. [U.][#][][] : # mark is the unit No.)

A-5) For the outdoor unit selected to pressure adjustment, execute the following operations.

- 1) Set the rotary switches on the interface P.C. board to the following numbers.
The presently operating low-pressure pressure data (MPa) is displayed.
 - SW03 [No.2]/SW02 [No.2]/Sw01 [No.1]
 - 7 segment display : [L][* .][*][*] (* : Value of Ps pressure sensor)
- 2) Observing the low pressure data, close service valve of the gas pipe gradually to adjust it to approximately 0.12MPa. (7 segment display : [L][0.][1][2])
- 3) Compare data with the pressure data of the failed outdoor unit.
- 4) After the pressure data displayed on two outdoor units is almost the same value, operate the units for a while, and then close service valve of the gas pipe fully.
- 5) When the service valve is closed fully, shift to the failed outdoor unit.

A-6) The outdoor unit selected for pressure adjustment stops automatically due to low pressure cut, etc. When the compressor has stopped, close immediately the service valve of balancing pipe of the failed outdoor unit fully.

A-7) Turn off the power supply of all the outdoor units. Reclaim operation is complete.

A-8) Recover the remained gas in the failed outdoor unit using a refrigerant recovery device. (Calculate the recovered refrigerant, and be sure to add the calculated amount of refrigerant after repair has completed.)

A-9) The refrigerant recovery work is finished.

<Work procedure (B)>

[In case that backup operation has been executed for fault of outdoor unit]

B-1) Turn on the power supply of all the outdoor units, and keep the system in stop status (Indoor unit stop).

If insulation of the compressor is insufficient, remove lead wire of the compressor before turning on the power supply.

B-2) For the failed outdoor unit, execute the operations in Work procedure A-2, from 1) to 4).

* During set up of backup, the system cannot automatically activate. Execute operation in item B-3).

Explanatory Diagram : Module Multi Service Valve

<Figure : Open/Close direction of service valve>

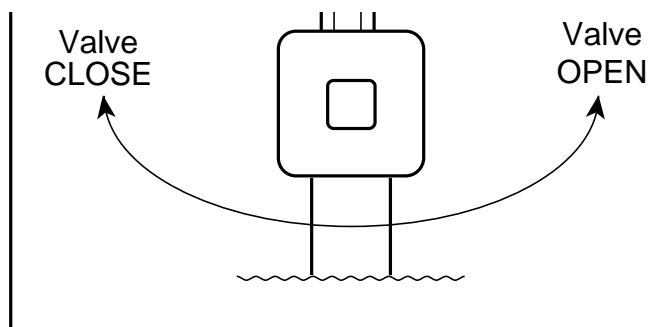

<Figure : Position of service valve>

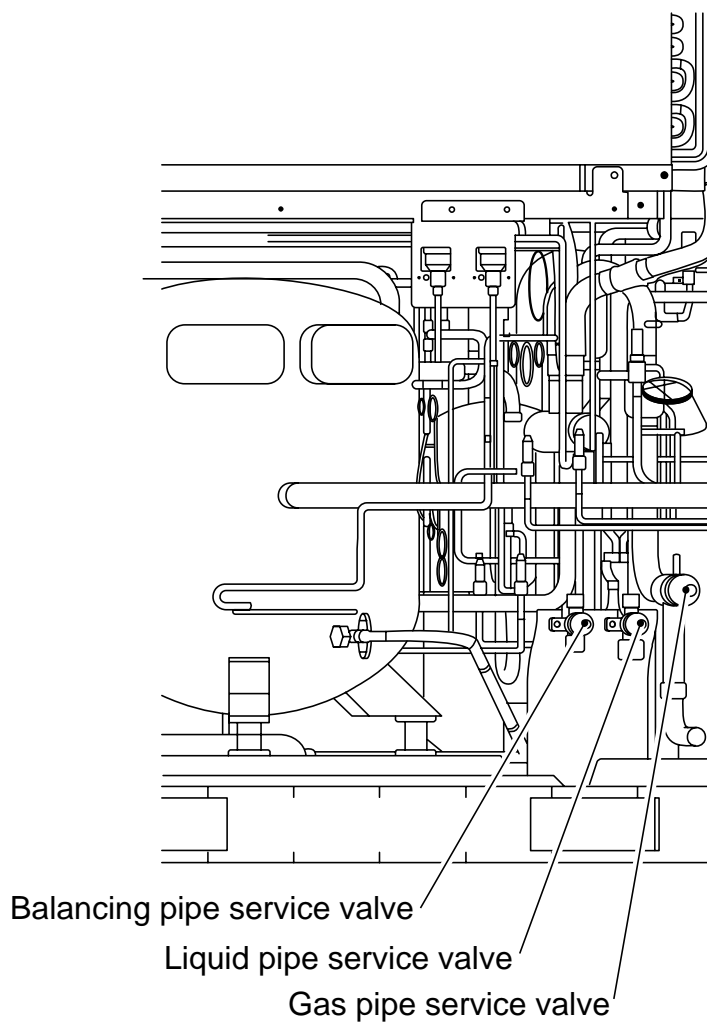

3-11. REPLACEMENT OF COMPRESSOR

3-11-1. Replacing Procedure of Compressor (Outline)

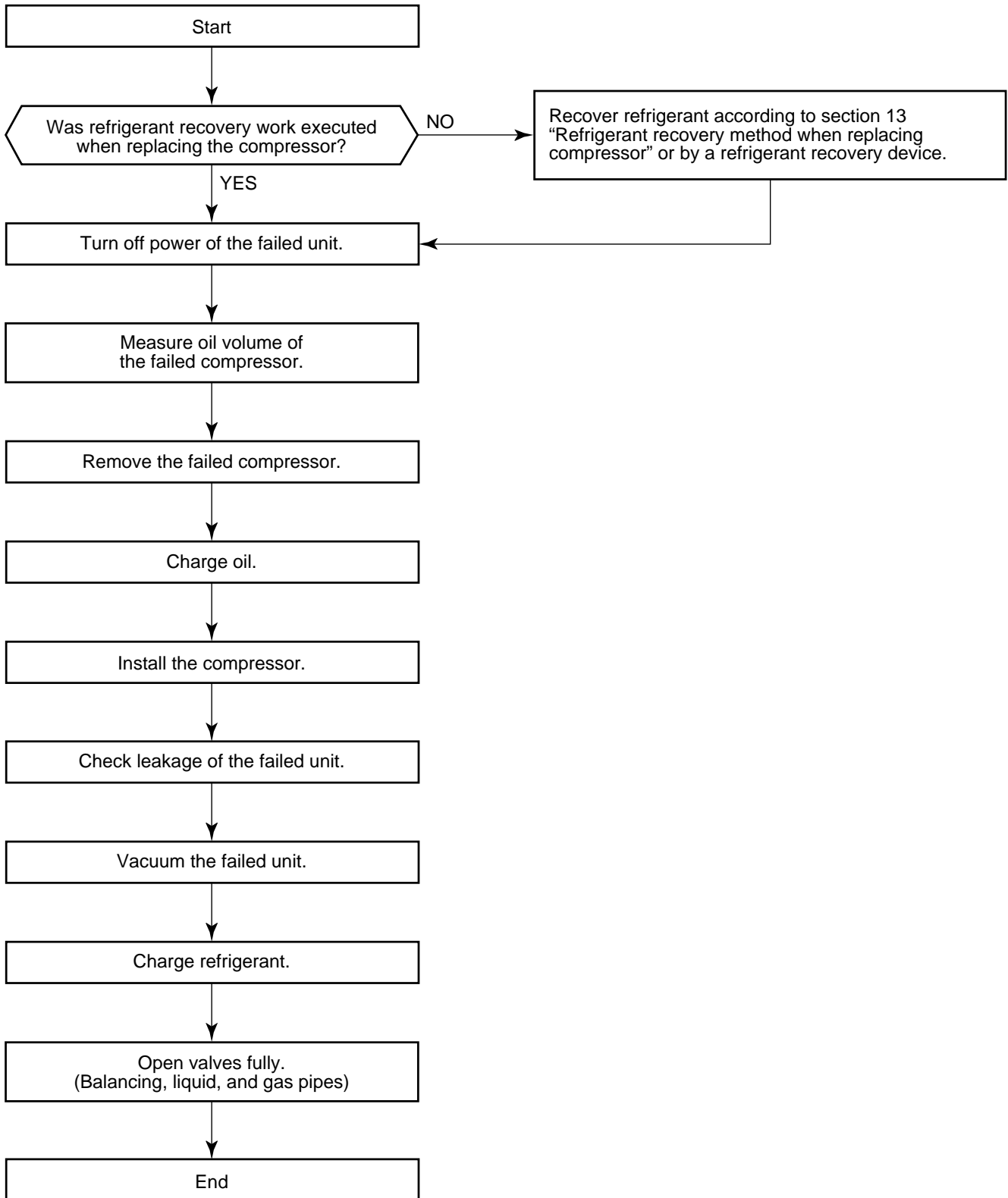

3-11-2. Replacing Method of Compressor

After recovery of refrigerant has completed, turn off the power supply, and replace the compressor according to the following method.

[In case of removal of the compressor from the front side]

1. Outdoor units (Inverter and fixed-speed units)

080, 100 type

<Removing of parts>

- Remove the front panel. (M5 x 7)
- Disconnect all wires connected to the electric parts box.
Temp. sensor, pressure sensor, complete, 2-way valve, PMV A*, PMV B and 4-way valve* , etc.
(* : It is not provided in the cooling only model.)
- Remove the electric parts box. (M5 x 4, M4 x 3)
- Remove the pressure sensor installation plate.
(Do not remove the pressure sensor.) (M4 x 2)
- Remove the cooling duct for the electric parts. (M5 x 5)
- Remove the crank case heater. (Only for fixed-speed unit)
- Remove the sound-proof mat.
- Remove the terminal cover of the compressor, and remove all wires.
- Close the valve located under the compressor fully using a hexadecimal wrench.

<Extraction of oil from compressor>

- Cut the case bypass located at the bottom of the compressor by height same as that of the suction pipe.
- Connect hose to the cut case bypass, and insert the opposite side of the hose in the container which oil is entered. 7.5 l or more oil may flow through the hose, so use a container with capacity of 8.0 l or more.
- Apply nitrogen gas with approx. 0.02MPa from service valve at gas side to extract oil.
(Extract oil completely.) (Be sure to spurt of oil when gas is applied exceedingly.)

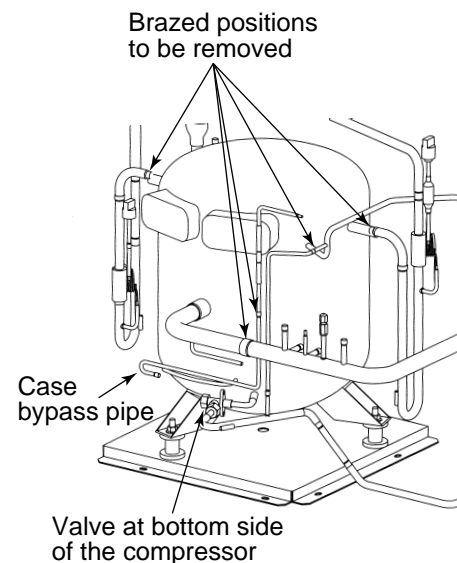

<Removing of compressor>

- Remove two discharge pipes, suction pipe, upper oil return piping, oil tank piping, and case bypass piping.

NOTE :

Take a great care that, in case of removing the pipe by heating with a torch the brazed part, if oil is remaining in the pipe, a flame may be emitted at the moment when flux has been melted.

- Loosen the flare nut at the bottom side of the compressor to remove the pipe.
- Remove the screws fixing the bottom plate for the compressor. (M5 x 6)
- Pull out the compressor with the bottom plate for the compressor.

NOTE :

Weight of the compressor is approx. 100 kg.

- Remove the nuts fixing the compressor. (M12 x 3)
- Remove the compressor.

<Measurement of oil volume>

- Measure oil volume extracted from the compressor, and determine whether to add oil or not.

Recovered oil volume (cc) – 7500 (cc) = Oil volume to be added (cc)
(If the calculated volume is minus value, addition is unnecessary.)

<Charging of oil>

Insert the hose up to the end of suction pipe mounting part of the compressor to be installed, and add the necessary amount of oil using funnel, etc.

<Installation>

- Install the compressor in the reverse order of removing of compressor.

NOTE :

After installation, open fully the valve at bottom side of the compressor, using hexagonal wrench.

<Vacuuming>

- Connect the vacuum pump to the check joint of the discharge and suction pipes, and operate the vacuum pump.
- Perform vacuuming until the vacuum low-pressure gauge indicates 1 (mmHg).

<Charging of refrigerant>

- Add refrigerant of the same volume to the recovered refrigerant into the check joint of the suction pipe.

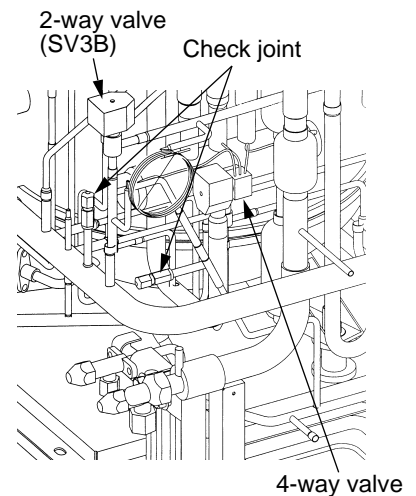

2. Outdoor unit (fixed-speed units) 060 type

<Removal of parts>

- Remove the front panel. (M5 x 7)
- Disconnect all wires connected to the electric parts box. Temp. sensor, pressure sensor, complete, 2-way valve, PMV A*, PMV B and 4-way valve* (* : It is not provided in the cooling only model.)
- Remove the electric parts box. (M5 x 4, M4 x 3)
- Remove the cooling duct for the electric parts. (M5 x 5)
- Remove the crank case heater.
- Remove the sound-proof mat.
- Remove the terminal cover of the compressor, and remove all wires.
- Close the valve located under the compressor fully using a hexadecimal wrench.

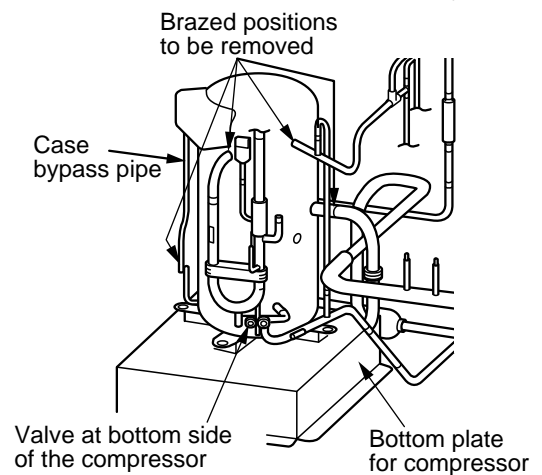

<Extraction of oil from compressor>

- Cut the case bypass located at the bottom of the compressor by height same as that of the suction pipe.
- Connect hose to the cut case bypass, and insert the opposite side of the hose in the container which oil is entered. 2 l or more oil may flow through the hose, so use a container with capacity of 2.5 l or more.
- Apply nitrogen gas with approx. 0.02MPa from service valve at gas side to extract oil. (Extract oil completely.) (Be sure to spurt of oil when gas is applied exceedingly.)

<Removing of compressor>

- Remove the discharge pipe, suction pipe, upper oil return piping, oil tank piping, and case bypass piping.

NOTE :

Take a great care that, in case of removing the pipe by heating with a torch the brazed part, if oil is remaining in the pipe, a flame may be emitted at the moment when flux has been melted.

- Loosen the flare nut at the bottom side of the compressor to remove the pipe.
- Remove the screws fixing the bottom plate for the compressor. (M5 x 6)
- Pull out the compressor with the bottom plate for the compressor.

NOTE :

Weight of the compressor is approx. 45 kg.

- Remove the nuts fixing the compressor. (M8 x 4)
- Remove the compressor.

<Measurement of oil volume>

- * Measure oil volume extracted from the compressor, and determine whether to add oil or not.
Recovered oil volume (cc) – 2000 (cc) = Oil volume to be added (cc) (If the calculated volume is minus value, addition is unnecessary.)

<Charging of oil>

Insert the hose up to the end of suction pipe mounting part of the compressor to be installed, and add the necessary amount of oil using a funnel, etc.

<Installation>

- Install the compressor in the reverse order of removing of compressor.

NOTE :

After installation, open fully the valve at bottom side of the compressor, using hexagonal wrench.

<Vacuuming>

- Connect the vacuum pump to the check joint of the discharge and suction pipes, and operate the vacuum pump.
- Perform vacuuming until the vacuum low-pressure gauge indicates 1 (mmHg).

<Charging of refrigerant>

Add refrigerant of the same volume to the recovered refrigerant into the check joint of the suction pipe.

[In case of removal of the compressor from the rear side]

1. Outdoor unit (Inverter and fixed-speed units)

080, 100 type

<Removing of parts>

- Remove the front panel. (M5 x 7)
- Disconnect all wires connected to the electric parts box. Temp. sensor, pressure sensor, complete, 2-way valve, PMV A*, PMV B and 4-way valve*, etc. (* : It is not provided in the cooling only model.)
- Remove the electric parts box. (M5 x 4, M4 x 3)
- Remove the cooling duct for the electric parts. (M5 x 5)
- Remove the crank case heater. (Only for constant-speed unit)
- Remove the sound-proof mat.
- Remove the terminal cover of the compressor, and remove all wires.
- Close the valve located under the compressor fully using a hexadecimal wrench.

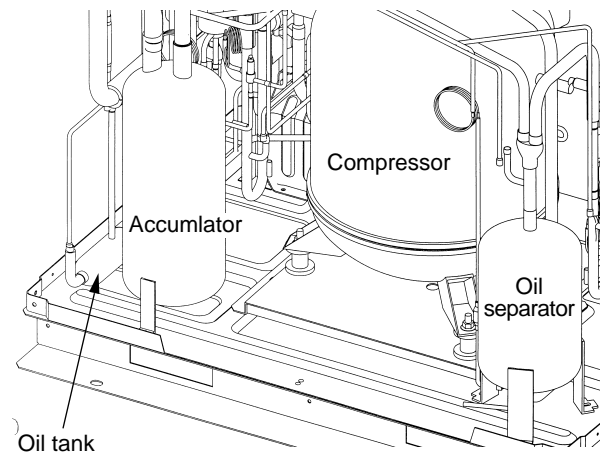

<Extraction of oil from compressor>

- Cut the case bypass located at the bottom of the compressor by height same as that of the suction pipe.
- Connect hose to the cut case bypass, and insert the opposite side of the hose in the container which oil is entered. 7.5 l or more oil may flow through the hose, so use a container with capacity of 8 l or more.
- Apply nitrogen gas with approx. 0.02MPa from service valve at gas side to extract oil. (Extract oil completely.) (Be sure to spurt of oil when gas is applied exceedingly.)

<Removing of compressor>

- Remove two discharge pipes, suction pipe, upper oil return piping, oil tank piping, and case bypass piping. (Same as case of pulling out from the front side)

NOTE :

Take great care that, in case of removing the pipe by heating with a torch the brazed part, if oil is remaining in the pipe, a flame may be emitted at the moment when flux has melted.

- Loosen the flare nut at the bottom side of the compressor to remove the pipe.
- Remove the screws fixing the bottom plate for the compressor. (M5 x 6)
- Pull out the compressor with the bottom plate for the compressor.

NOTE :

Weight of the compressor is approx. 100kg.

- Remove the nuts fixing the compressor. (M12 x 3)
- Remove the compressor.

<Measurement of oil volume>

- Measure oil volume extracted from the compressor, and determine whether to add oil or not.
Recovered oil volume (cc) – 7500 (cc) = Oil volume to be added (cc)
(If the calculated volume is minus value, addition is unnecessary.)

<Charging of oil>

Insert the hose up to the end of suction pipe mounting part of the compressor to be installed, and add the necessary amount of oil using funnel, etc.

<Installation>

- Install the compressor in the reverse order of removing of compressor.

NOTE :

After installation, open fully the valve at bottom side of the compressor, using hexagonal wrench.

<Vacuuming>

- Connect the vacuum pump to the check joint of the discharge and suction pipes, and operate the vacuum pump.
- Perform vacuuming until the vacuum low-pressure gauge indicates 1 (mmHg).

<Charging of refrigerant>

- Add refrigerant of the same volume to the recovered refrigerant into the check joint of the suction pipe.

2. Outdoor unit (Fixed-speed units)**060 type****<Removing of parts>**

- Remove the front panel. (M5 x 7)
- Disconnect all wires connected to the electric parts box.
Temp. sensor, pressure sensor, complete, 2-way valve, PMV A*, PMV B and 4-way valve*, etc.
(* : It is not provided in the cooling only model.)
- Remove the electric parts box. (M5 x 4, M4 x 3)
- Remove the cooling duct for electric parts. (M5 x 5)
- Remove the crank case heater.
- Remove the sound-proof mat.
- Remove the terminal cover of the compressor, and remove all wires.
- Remove two temp. sensors for oil detection from the pipe.
- Close the valve located under the compressor fully using a hexadecimal wrench.

<Extraction of oil from compressor>

- Cut the case bypass located at the bottom of the compressor by height same as that of the suction pipe.
- Connect hose to the cut case bypass, and insert the opposite side of the hose in the container which oil is entered. 2.0 l or more oil may flow through the hose, so use a container with capacity of 2.5 l or more.
- Apply nitrogen gas with approx. 0.02MPa from service valve at gas side to extract oil. (Extract oil completely.) (Be sure to spurt of oil when gas is applied exceedingly.)

<Removing of compressor>

- Remove the discharge pipe, suction pipe, upper oil return piping, oil tank piping, and case bypass piping. (Same as case of pulling out from the front side)

NOTE :

Take great care that, in case of removing the pipe by heating with a torch the brazed part, if oil is remaining in the pipe, a flame may be emitted at the moment when flux has melted.

- Loosen the flare nut at the bottom side of the compressor to remove the pipe.
- Remove the metal fixing the oil tank. (M4 x 2)
- Remove the oil tank. (Two brazing positions)

NOTE :

Take great care that, in case of removing the pipe by heating with a torch the brazed part, if oil is remaining in the pipe, a flame may be emitted at the moment when flux has melted.

- Remove the screws fixing the bottom plate for the compressor. (M5 x 6)
- Pull out the compressor with the bottom plate for the compressor.

NOTE :

Weight of the compressor is approx. 45kg.

- Remove the nuts fixing the compressor. (M8 x 4)
- Remove the compressor.

<Measurement of oil volume>

- Measure oil volume extracted from the compressor, and determine whether to add oil or not.
Recovered oil volume (cc) – 2000 (cc) = Oil volume to be added (cc)
(If the calculated volume is minus value, addition is unnecessary.)

<Charging of oil>

Insert the hose up to the end of suction pipe mounting part of the compressor to be installed, and add the necessary amount of oil using a funnel, etc.

<Installation>

- Install the compressor in the reverse order of removing of compressor.

NOTE :

After installation, open fully the valve at bottom side of the compressor, using hexagonal wrench.

<Vacuuming>

- Connect the vacuum pump to the check joint of the discharge and suction pipes, and operate the vacuum pump.
- Perform vacuuming until the vacuum low-pressure gauge indicates 1 (mmHg).

<Charging of refrigerant>

Add refrigerant of the same volume to the recovered refrigerant into the check joint of the suction pipe.

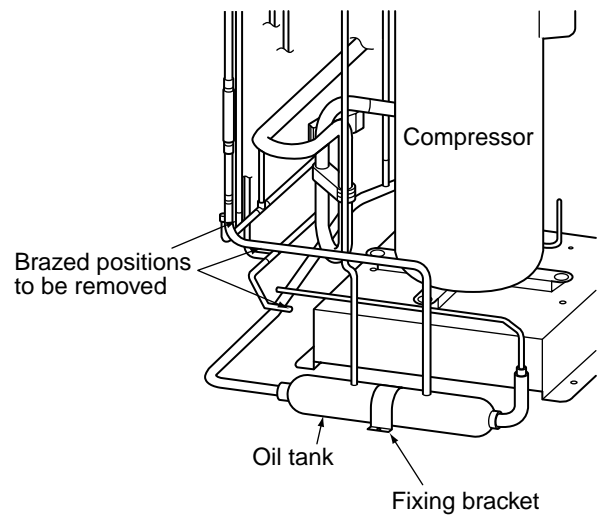

3-12. REPLACING METHOD OF PARTS

3-12-1. Replacement and Check of Electric Parts

- Remove the front panel. (M5 x 7)
- Disconnect all wires connected to the electric parts box.
Temp. sensor, pressure sensor, complete, 2-way valve, PMV A*, PMV B and 4-way valve*, etc.
(* : It is not provided in the cooling only model.)
- Remove the electric parts box. (M5 x 4, M4 x 3)
Since the upper part of the box is formed as hanging shape, lift up the box and pull out toward you.

3-12-2. Replacement of Propeller Fan/Fan Motor

- Remove the fan guard. (M4 x 6)
- Loosen tightening screw of the propeller fan with a hexagonal wrench, and remove the propeller fan upward.
- Remove the front panel, and remove the fan motor lead connector in the electric parts box.
- Remove the discharge cabinet. (M5 x 4)
- Remove the suction panel at the front side. (M5 x 4, M4 x 2)
- Remove the tie wrap, etc. which fix the fan motor lead wire, and pull in the fan motor lead wire closer to the fan motor.
- Remove the fan motor from the fan base. (M8 x 4)

NOTE :

Weight of the fan motor is approx. 10kg.

If screws of the motor, etc. fall inside of the cabinet, it may be difficult to pick them up.

3-12-3. Replacement of Accumulator

- Recover refrigerant.
- Remove the front panel. (M5 x 7)
- Remove the panel at rear side. (M5 x 7)
- Remove pipe connected to the accumulator.
- Remove the screws fixing the accumulator. (M6 x 2)
- Replace the accumulator.

3-12-4. Replacement of Liquid Tank

- Recover the refrigerant.
- If the liquid tank is installed with connection, remove the connecting pipe and pull out the outdoor unit.
- Remove the discharge cabinet. (M5 x 4)
- Remove the front panel. (M5 x 7)
- Remove the suction panel at the front side. (M5 x 4, M4 x 2)
- Remove the panel at the rear side. (M5 x 7)
- Remove the suction panel at the rear side. (M5 x 4, M4 x 2)
- Remove the left side plate. (M5 x 8, M4 x 2)
- Remove the fan base. (M8 x 4)
- Remove the evaporator cover. (M5 x 2, M4 x 1)
- Remove the waterproof board. (M4 x 3)
- Remove the heat exchanger at the front side. (M5 x 2, two brazing positions)
- Remove the pipe connected to the liquid tank.
- Remove the screws fixing the liquid tank. (M6 x 3)
- Replace the liquid tank.

3-12-5. Replacement of Heat Exchanger

- Recover the refrigerant.
- If the heat exchanger is installed by connection, remove the connecting pipe and pull out the outdoor unit.
- Remove the discharge cabinet. (M5 x 4)
- Remove the front panel. (M5 x 7)
- Remove the suction panel at the front side. (M5 x 4, M4 x 2)
- Remove the panel at the rear side. (M5 x 7)
- Remove the suction panel at the rear side. (M5 x 4, M4 x 2)
- Remove the left and right side plate. (M5 x 16, M4 x 4)
- Remove the fan base. (M8 x 4)
- Remove the waterproof board. (M4 x 3)
- Remove the screws fixing the waterproof board. (M4 x 2)
- Remove the evaporator cover at left and right sides. (M5 x 4, M4 x 1)
- Remove the temperature sensor for defrost operation. (1 pc)
- Remove the heat exchanger at the front and rear sides. (M5 x 4, four brazing positions)
- Replace the heat exchanger.

3-12-6. Replacement of Oil Separator

- Recover the refrigerant.
- Remove the front panel. (M5 x 7)
- Remove the rear panel. (M5 x 7)
- Disconnect all wires connected to the electric parts box.
Temp. sensor, pressure sensor, complete, 2-way valve, PMV A*, PMV B and 4-way valve*, etc.
(* : It is not provided in the cooling only model.)
- Remove the electric parts box. (M5 x 4, M4 x 3)
Since the upper part of the box is formed as hanging shape, lift up the box and pull out toward you.
- Remove the cooling duct for electric parts. (M5 x 5)
- Remove the pipe connected to oil separator.

NOTE :

Take a great care that, in case of removing the pipe by heating with a torch the brazed part, if oil is remaining in the pipe, a flame may be emitted at the moment when flux has been melted.

- Remove the screws fixing oil separator. (M6 x 3)
- Replace the oil separator.

3-12-7. Replacement of Pressure Sensor

- Remove the front panel. (M5 x 7)
- Remove lead wire connector of the pressure sensor to be replaced from the interface P.C. board.
- Braze capillary tube of the pressure sensor to be replaced after pinching, and remove it from the refrigerating cycle.
- Remove the pressure sensor to be replaced from the pressure sensor mounting board. (M4 x 1)

- Mount the pressure sensor for servicing to the pressure sensor mounting board. (M4 x 1)
- Mount the lead wire connector of the pressure sensor for servicing to the interface P.C. board.
- Connect the flare to the check joint of the piping part.
The check joints are provided in one position at high pressure side and low pressure side each.

3-13. EXPLODED VIEWS AND PARTS LIST

MMU-P0121H, P0151H, P0181H, P0241H, P0301H, P0361H, P0481H

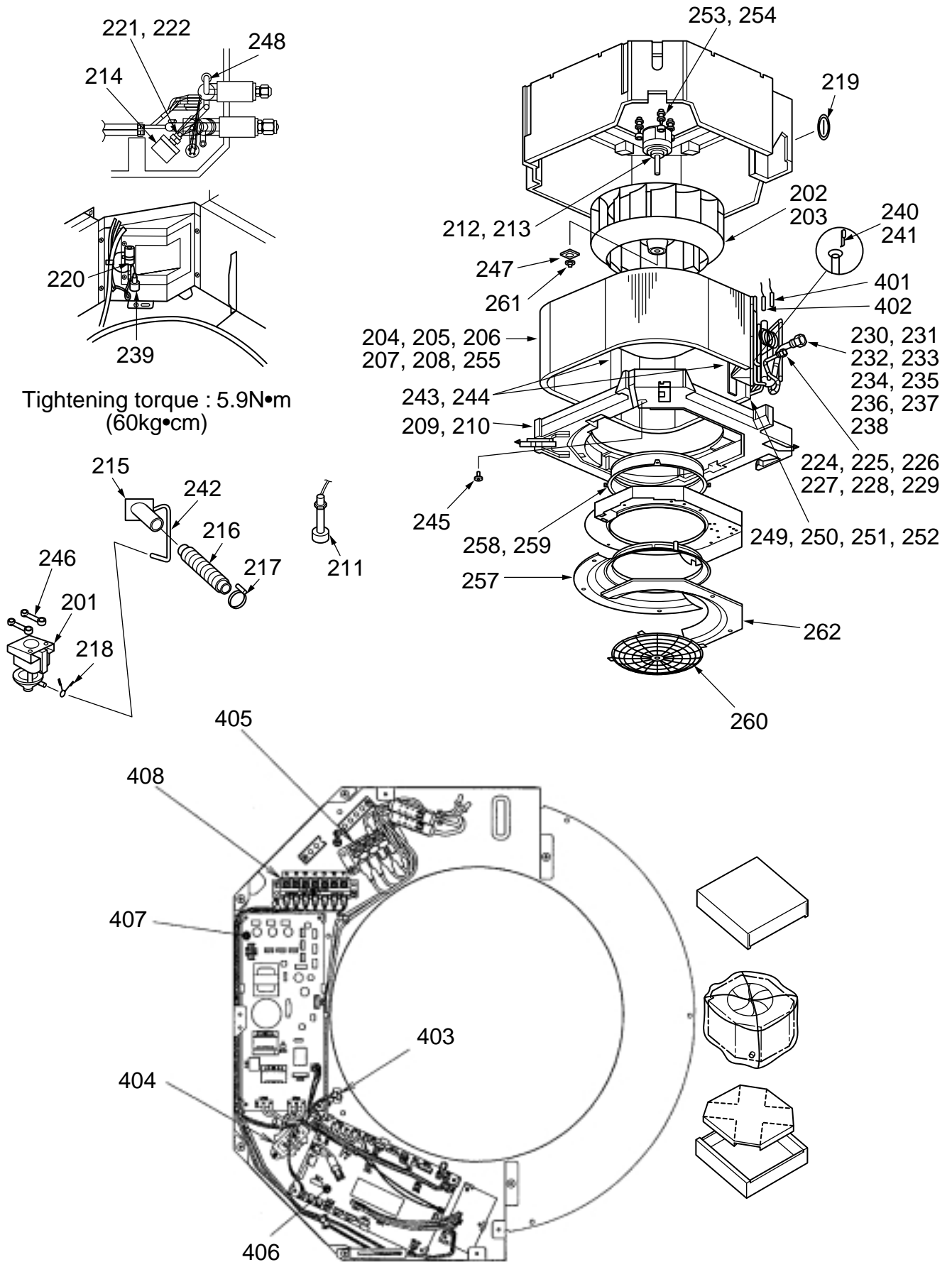

Location No.	Part No.	Description	Model name				MMU-		
			P0121H	P0151H	P0181H	P0241H	P0301H	P0361H	P0481H
201	43121688	Pump, Drain, PJV-05230TF 220-240V 50Hz	1	1	1	1	1	1	1
202	43120201	Fan, Ass'y Turb TB461	1	1	1	1	1		
203	43121673	Fan, Ass'y Turb TY461						1	1
204	4314J061	Refrigeration Cycle Ass'y	1						
205	4314J070	Refrigeration Cycle Ass'y			1				
206	4314J063	Refrigeration Cycle Ass'y				1	1		
207	4314J080	Refrigeration Cycle Ass'y						1	
208	4314J081	Refrigeration Cycle Ass'y							1
209	43172154	Pan Ass'y, Drain	1						
210	43172156	Pan Ass'y, Drain		1	1	1	1	1	1
211	43151246	Switch, Float FS-0208-601 750L	1	1	1	1	1	1	1
212	43121672	Motor, Fan ICF-230-60-1	1	1	1	1	1		
213	43121680	Motor, Fan MF-200-90-2						1	1
214	43146555	Motor, PMV EDM-MD12TF-3	1	1	1	1	1	1	1
215	43170213	Socket, Drain PVC	1	1	1	1	1	1	1
216	43170214	Hose, Drain 25A	1	1	1	1	1	1	1
217	43179119	Band, Hose 35-40	1	1	1	1	1	1	1
218	43179117	Band, Hose	1	1	1	1	1	1	1
219	43196109	Bushing, 38	1	1	1	1	1	1	1
220	43146383	Joint, Check	1	1	1	1	1	1	1
221	43146510	PMV, F25	1						
222	43146511	PMV, F40		1	1	1	1	1	
223	43146512	PMV, F60							1
224	43047545	Nut, Flare 1/4 IN	1	1					
225	43047546	Nut, Flare 3/8 IN			1	1	1	1	1
226	43194051	Socket, 1/4	1	1					
227	43194026	Socket, 3/8			1	1	1	1	1
228	43049697	Bonnet, 1/4	1	1					
229	43047609	Bonnet, 3/8			1	1	1	1	1
230	43194081	Nut, Flare 1/2 IN	1	1					
231	43194078	Nut, Flare 5/8 IN			1	1	1		
232	43194019	Nut, Flare 3/4 IN						1	1
233	43194080	Socket, 1/2	1	1					
234	43194079	Socket, 5/8			1	1	1		
235	43171022	Socket, 3/4						1	1
236	43147195	Bonnet, 1/2 IN	1	1					
237	43194029	Bonnet, 5/8			1	1	1		
238	43147451	Bonnet, 3/4" IN						1	1
239	43149255	Sensor-Pressure, 150F/160NH6-D	1	1	1	1	1	1	1
240	43107215	Holder, Sensor	1	1	1	1	1	1	1
241	43019822	Holder, Sensor	1	1	1	1	1	1	1
242	43170215	Hose, Drain	1	1	1	1	1	1	1
243	43122057	Plate, Wind	2	2	2	2	2		
244	43122058	Plate, Wind						1	1
245	43179110	Plug	1	1	1	1	1	1	1
246	43139123	Rubber	2	2	2	2	2	2	2
247	43139129	Washer, FIX-FAN	1	1	1	1	1	1	1
248	43148151	Strainer	1	1	1	1	1	1	1
249	43147580	Distributor Ass'y, Service 2.2 x 2P x 800L	1						
250	43147582	Distributor Ass'y, Service 2.0 x 4P x 1000L			1				
251	43147583	Distributor Ass'y, Service 2.0 x 5P x 1000L				1	1		
252	43147578	Distributor Ass'y, Service 2.0 x 10P x 1000L						1	1
253	43139118	Rubber	3	3	3	3	3		
254	43139130	Cushion, Rubber						3	3
255	4314J062	Refrigeration Cycle Ass'y		1					
256	43147581	Distributor Ass'y Service 2.0 x 3P x 100L		1					
257	43122067	Bellmouth (A)	1	1	1	1	1	1	1
258	43122068	Bellmouth (B)						1	1
259	43122069	Bellmouth (B)	1	1	1	1	1		
260	43191632	Fan Guard	1	1	1	1	1	1	1
261	43097166	Nut	1	1	1	1	1	1	1
262	43162043	Cover E-P	1	1	1	1	1	1	1
401	43050382	Sensor, TC (F6)	1	1	1	1	1	1	1
402	43050398	Sensor, TG (F4)	1	1	1	1	1	1	1
403	43050400	Sensor, TA 10K, 25C	1	1	1	1	1	1	1
404	43158165	Transformer, Power	1	1	1	1	1	1	1
405	43160427	Terminal, 5P	1	1	1	1	1	1	1
406	4316V164	P.C. Board Ass'y (Main DC) MCC-1361	1	1	1	1	1	1	1
407	4316V167	P.C. Board Ass'y (Motor DC) MCC-1382	1	1	1	1	1	1	1
408	43160516	Terminal, 2P (L, N)	1	1	1	1	1	1	1

MMU-P0121H, P0151H, P0181H, P0241H, P0301H, P0361H, P0481H

Distributor Assembly for Exchange Method

1. Cutting dimension of capillary tubes

Distributor assembly attached capillary tubes brazed.
Please cut each as below length.

ReF No.	Quantity	Inner diameter	Cutting Dimension
252	10	2.0 mm	Cut off the 375mm (8 pcs.) Cut off the 310mm (1 pc.) Cut off the 250mm (1 pc.)

(Cutting Method)

Shave the circumference of capillary tube with a triangle file or cutter knife, then shape it.

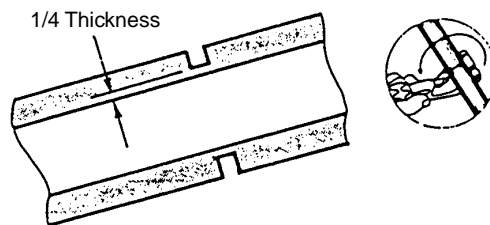

(Caution)

Don't deform the inner diameter of capillary tube.

2. Brazing method of joint pipe

Insert the tip of the capillary tube into the joint to 15mm depth.

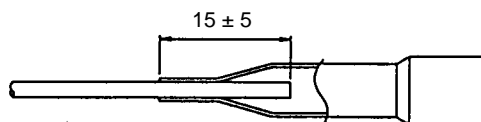

Form the capillary tubes as distributor of before exchanging.

3. Brazing method to indoor heat exchanger.

Attach the brazed capillary tubes to the tip of pipe as below diagram.

(Caution)

Be careful with capillary length and insert position.

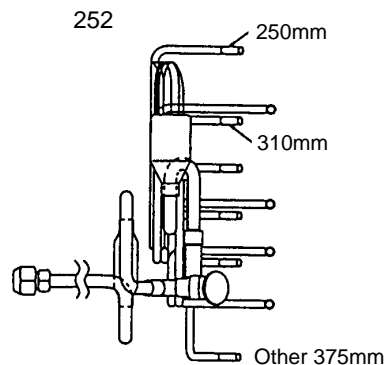

RBC-U466PG

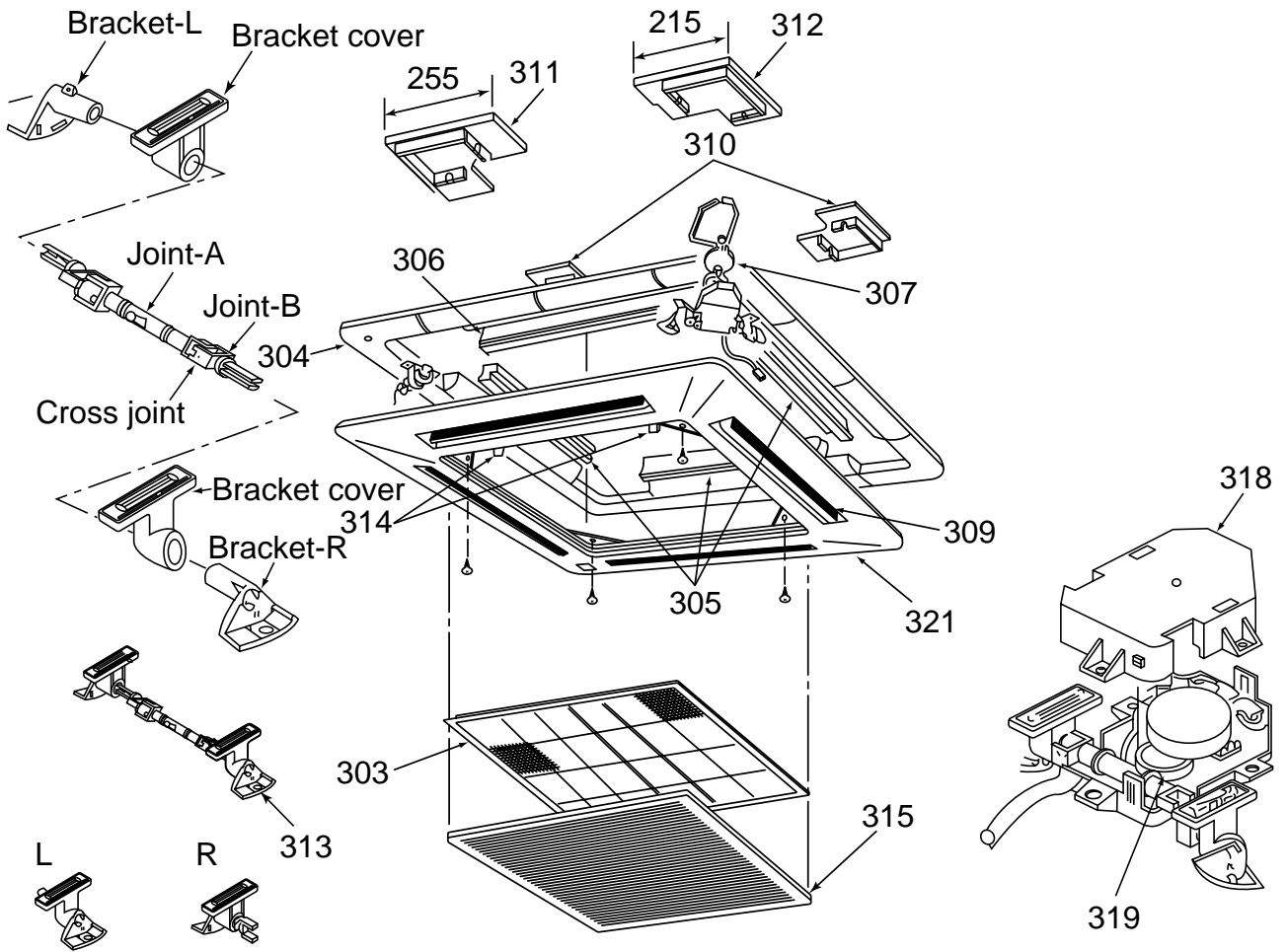

Location No.	Part No.	Description	Model name
			RBC-U466PG
303	43180298	Air Filter, PP	1
304	43111313	Outlet, Air Foam PS-F	1
305	43111314	Outlet, Air Foam PS-F	3
306	43111315	Outlet, Air Foam PS-F	1
307	43121671	Motor, Geard	1
309	43409136	Louver, ABS	4
310	43111316	Outlet, Air Foam PS-F	2
311	43111317	Outlet, Air Foam PS-F	1
312	43111318	Outlet, Air Foam PS-F	1
313	43407085	Joint, Kit POM, ABS	2
314	43407105	Grille, Catch PAC	2
315	43409138	Grille, Ass'y Air Inlet, PP	1
318	43107250	Motor, Ass'y Kit	1
319	43107246	Cam Ass'y, Service PA66	1
321	43400014	Panel	1

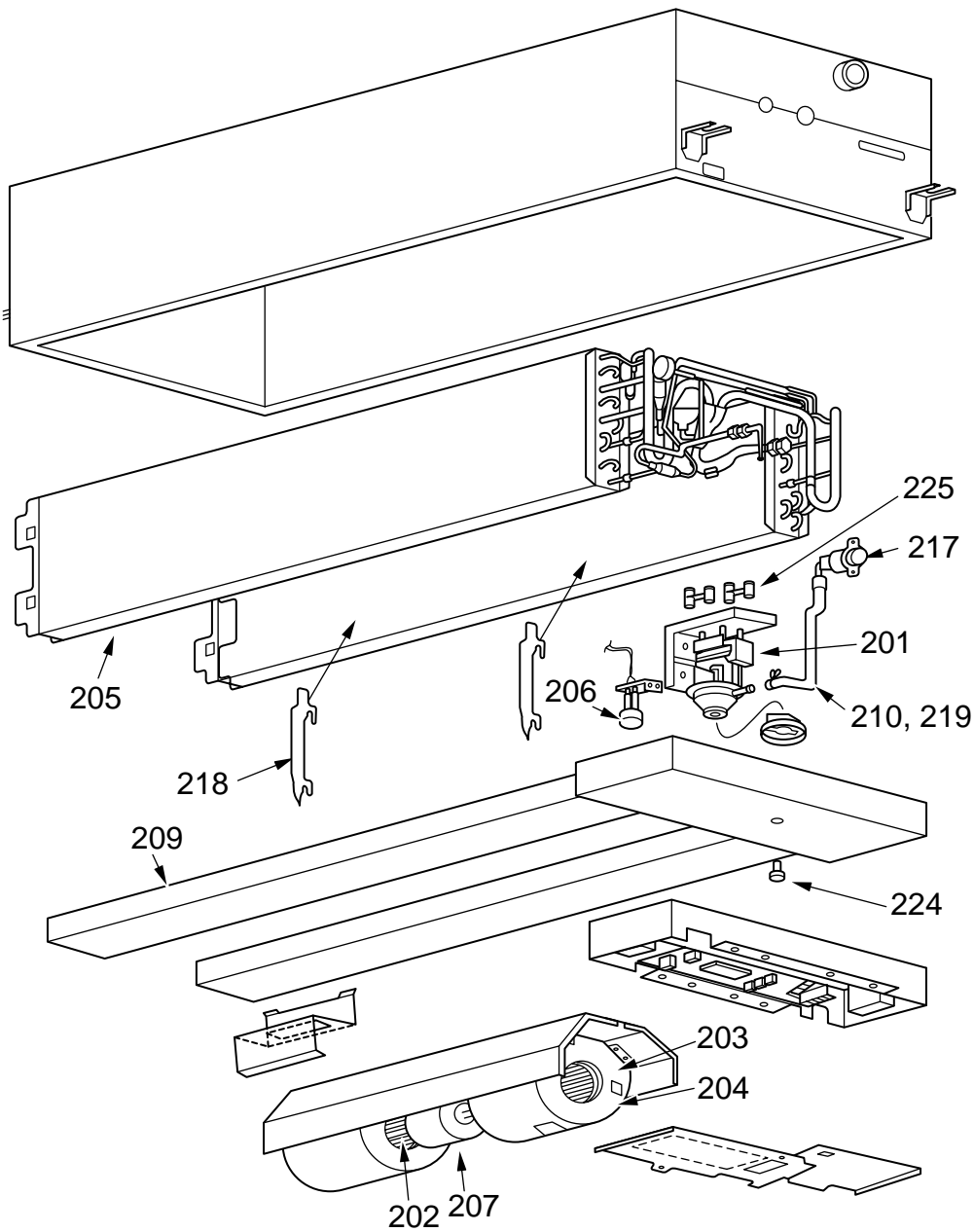

Location No.	Part No.	Description	Model name		
			MMU-P0071WH	MMU-P0091WH	MMU-P0121WH
201	43121667	Pump, Drain, PJV-0739	1	1	1
202	43120190	MLB Fan Ass'y	1	1	1
203	43122047	Fan, Case Upper	1	1	1
204	43122048	Fan, Case Down	1	1	1
205	43144761	Refrigeration Cycle Ass'y	1	1	1
206	43151245	Float, Switch	1	1	1
207	43121649	Fan, Motor	1	1	1
209	43172141	Drain Pan, Ass'y	1	1	1
210	43179117	Band, Hose	1	1	1
217	43070146	Hose, Drain	1	1	1
218	43022408	Plate, Wind	2	2	2
219	43170210	Hose, Drain	1	1	1
224	43179110	Plug	1	1	1
225	43139123	Rubber	2	2	2

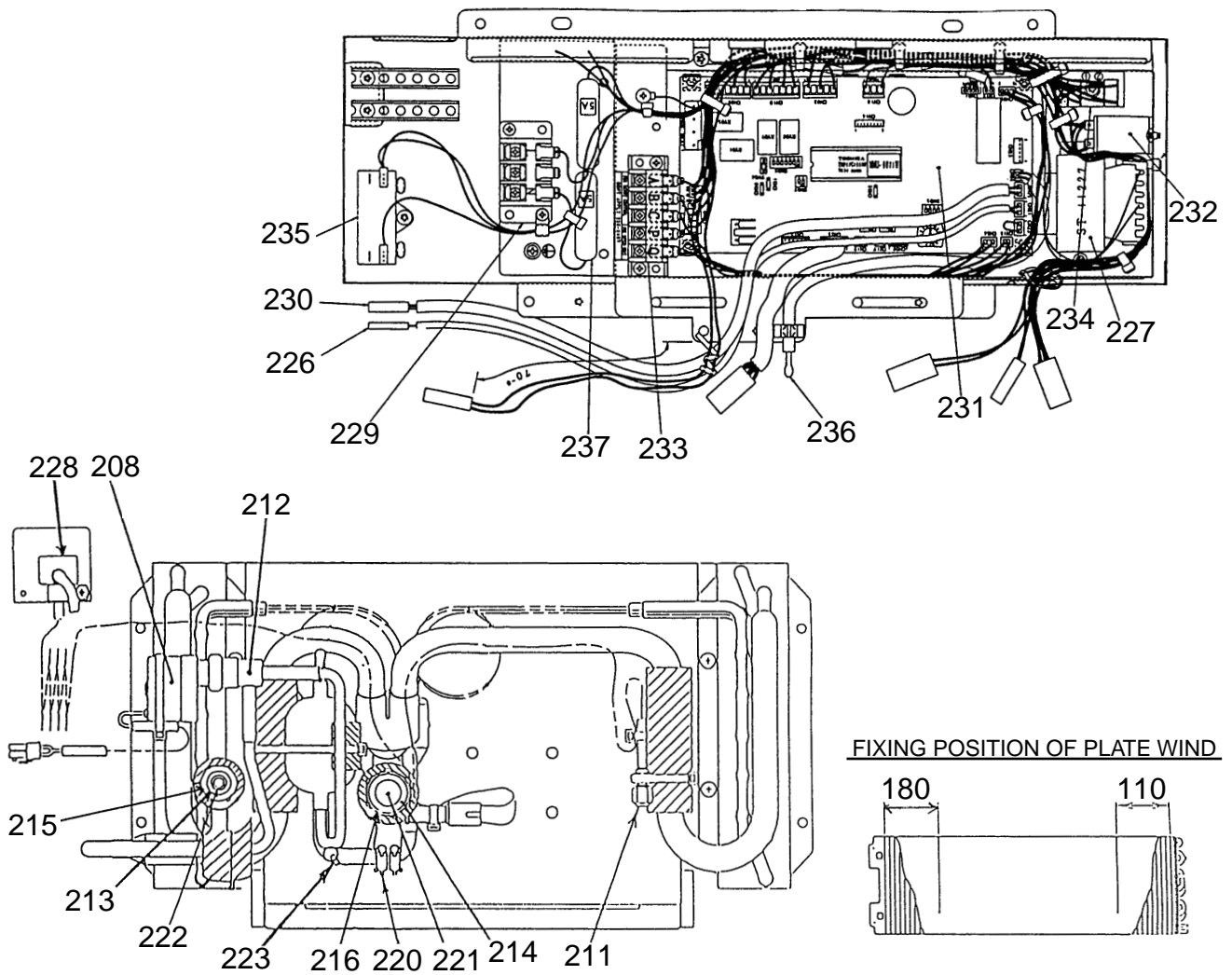

Location No.	Part No.	Description	Model name MMU-		
			P0071WH	P0091WH	P0121WH
208	43146555	Motor, PMV	1	1	1
211	43146383	Joint, Check	1	1	1
212	43146510	PMV	1	1	1
213	43047545	Nut, Flare, 1/4 IN	1	1	1
214	43194038	Nut, Flare, 1/2 IN	1	1	1
215	43194051	Socket	1	1	1
216	43194054	Socket	1	1	1
220	43107215	Holder, Sensor	1	1	1
221	43147195	Bonnet, 1/2 IN	1	1	1
222	43049697	Bonnet	1	1	1
223	43019822	Holder, Sensor	1	1	1
226	43150241	Sensor	1	1	1
227	43158166	Transformer, Power, ST-11227	1	1	1
228	43149255	Sensor-Pressure	1	1	1
229	4306A015	Terminal Block, 2P	1	1	1
230	43150223	Sensor	1	1	1
231	4316V045	P,C, Board Ass'y	1	1	1
232	43154156	Relay	1	1	1
233	43160427	Terminal, 5P	1	1	1
234	43160467	Terminal, 2P	1	1	1
235	43155079	Capacitor, Electrolytic, 4MFD, 400V	1	1	1
236	43069864	Sensor	1	1	1
237	43160468	Fuse	2	2	2

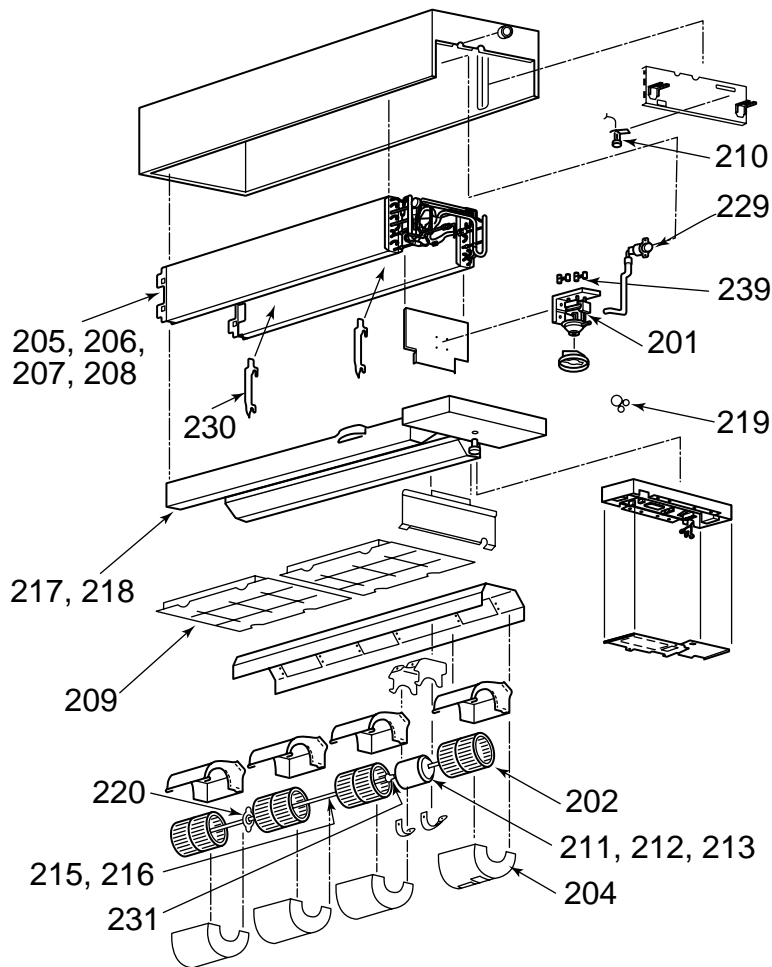

Location No.	Part No.	Description	Model name				
			P0121H	P0151H	P0181H	P0241H	P0301H
201	43121688	Pump, Drain, PJV-05230TF	1	1	1	1	1
202	43120201	Fan Ass'y Turb	1	1	1	1	1
204	4314J061	Refrigeration cycle Ass'y	1				
205	4314J070	Refrigeration cycle Ass'y			1		
206	4314J063	Refrigeration cycle Ass'y				1	1
209	43172154	Pan Ass'y, Drain	1				
210	43172156	Pan Ass'y, Drain		1	1	1	1
211	43151246	Switch, Float	1	1	1	1	1
212	43121672	Motor, Fan	1	1	1	1	1
215	43170213	Socket, Drain	1	1	1	1	1
216	43170214	Hose, Drain	1	1	1	1	1
217	43179119	Band, Hose	1	1	1	1	1
218	43179117	Band, Hose	1	1	1	1	1
219	43196109	Bushing	1	1	1	1	1
220	43146383	Joint, Check	1	1	1	1	1
229	43047609	Bonnet			1	1	1
230	43194081	Nut, Flare, 1/2 IN	1	1			
231	43194078	Nut, Flare, 5/8 IN			1	1	1
239	43149255	Sensor-Pressure	1	1	1	1	1
253	43139118	Rubber	3	3	3	3	3
255	4314J062	Refrigeration cycle Ass'y		1			
256	43147581	Distributor Ass'y, Service		1			

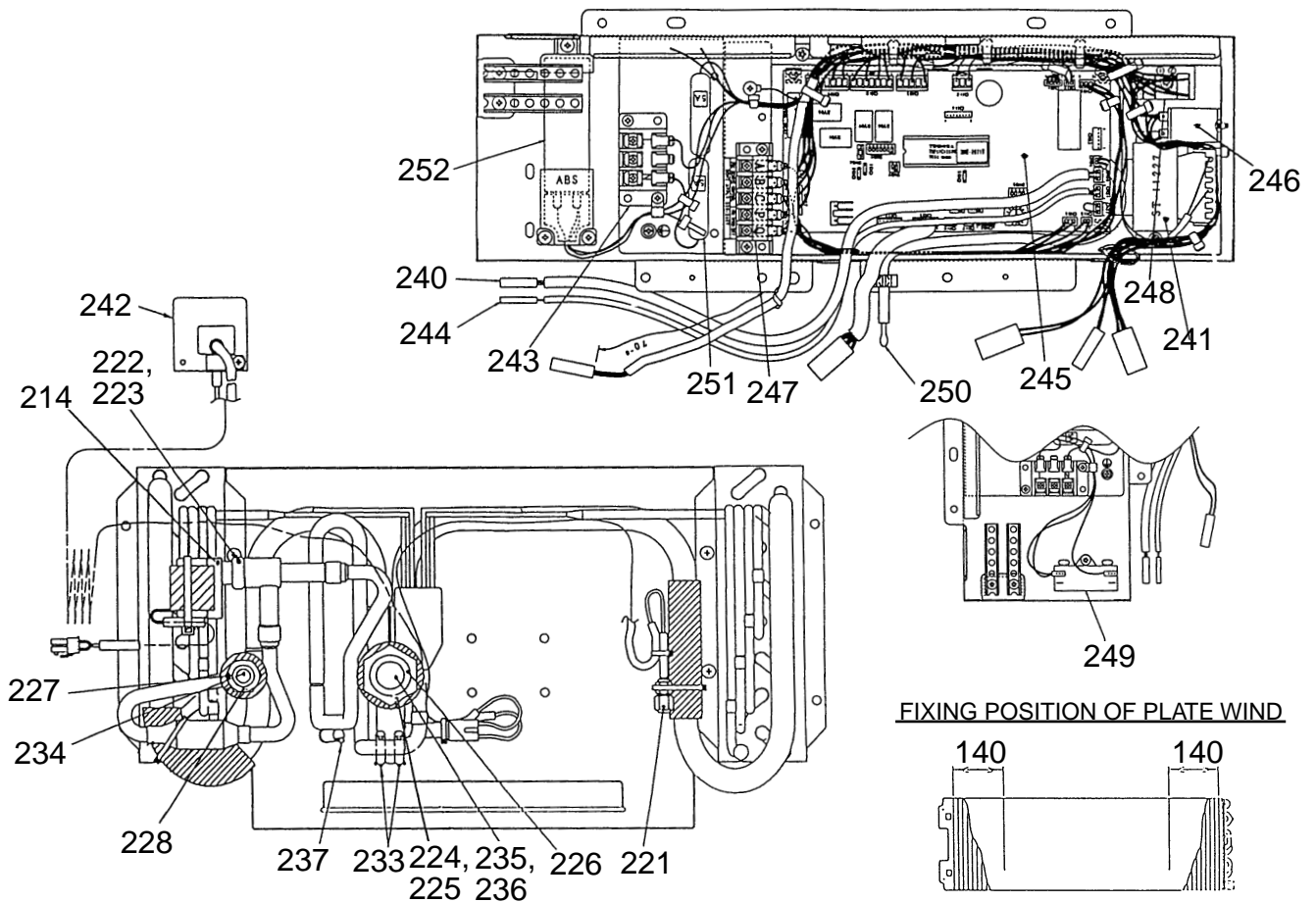

Location No.	Part No.	Description	Model name MMU-				
			P0121H	P0151H	P0181H	P0241H	P0301H
214	43146555	Motor, PMV	1	1	1	1	1
221	43146510	PMV	1				
222	43146511	PMV		1	1	1	1
224	43047545	Nut, Flare, 1/4 IN	1	1			
225	43047546	Nut, Flare, 3/8 IN			1	1	1
226	43194051	Socket	1	1			
227	43194026	Socket			1	1	1
228	43049697	Bonnet	1	1			
233	43194080	Socket	1	1			
234	43194079	Socket			1	1	1
236	43147495	Bonnet, 1/2 IN	1	1			
237	43194029	Bonnet			1	1	1
240	43107215	Holder, Sensor	1	1	1	1	1
241	43019822	Holder, Sensor	1	1	1	1	1
242	43170215	Hose, Drain	1	1	1	1	1
243	43122057	Prate, Wind	2	2	2	2	2
245	43179110	Plug	1	1	1	1	1
246	43139123	Rubber	2	2	2	2	2
247	43139129	Washer, FIX-Fan	1	1	1	1	1
248	43148151	Strainer	1	1	1	1	1
249	43147580	Distributor Ass'y, Service	1				
250	43147582	Distributor Ass'y, Service			1		
251	43147583	Distributor Ass'y, Service				1	1

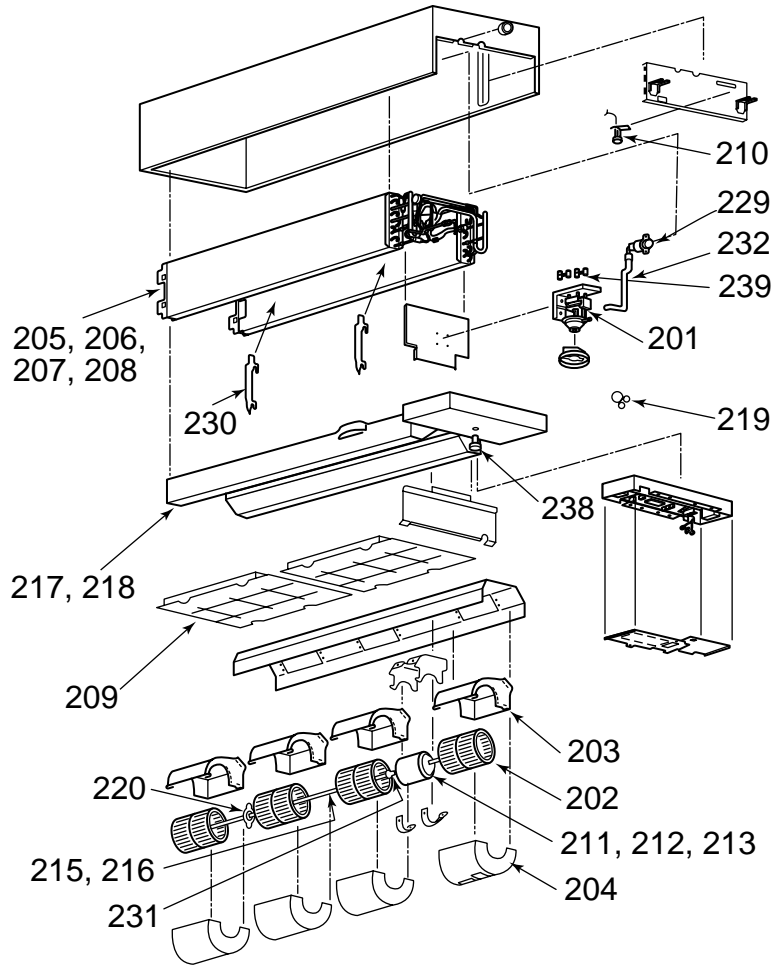

Location No.	Part No.	Description	Model name	
			P0361WH	MMU-P0481WH
201	43121667	Pump, Drain, PJV-0739	1	1
202	43120190	MLB Fan Ass'y	4	4
203	43122047	Fan, Case Upper	4	4
204	43122048	Fan, Case Down	4	4
205	43144758	Refrigeration cycle Ass'y		
206	43144760	Refrigeration cycle Ass'y		
207	4314J046	Refrigeration cycle Ass'y	1	
208	4314J047	Refrigeration cycle Ass'y		1
209	43180301	Air Filter	2	2
210	43151245	Float, Switch	1	1
211	43121649	Fan, Motor		
212	43121662	Motor, Fan	1	1
213	43121650	Motor, Fan		
215	43125147	Shaft		
216	43125149	Shaft	1	1
217	43172140	Drain Pan, Ass'y		
218	43172148	Drain Pan, Ass'y	1	1
219	43179117	Band, Hose	1	1
220	43125131	Bearing, Shaft	1	1
229	43070146	Hose, Drain	1	1
230	43022408	Plate, Wind		
231	43125142	Coupling	1	1
232	43170210	Hose, Drain	1	1
238	43179110	Plug	1	1
239	43139123	Rubber	2	2

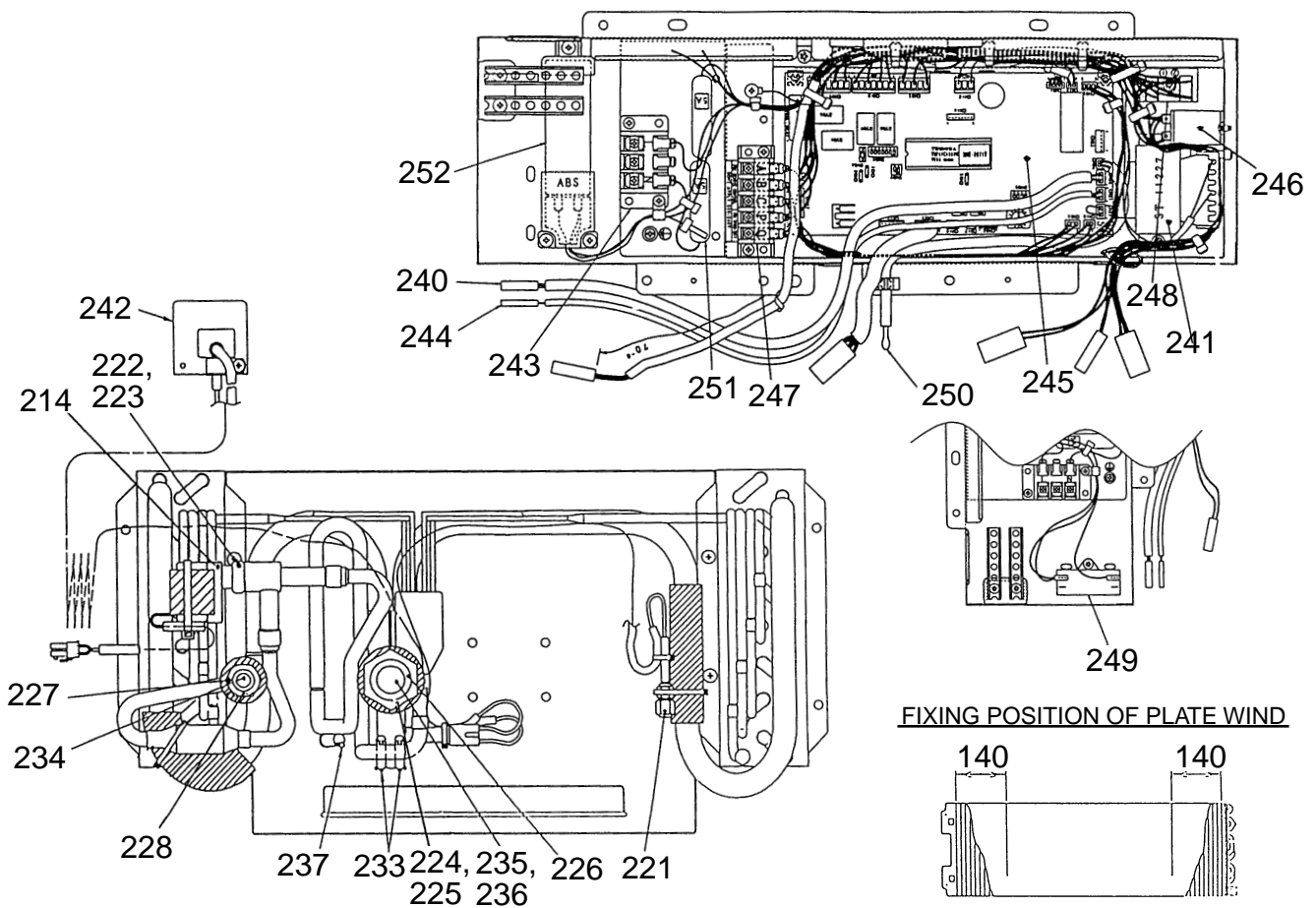

Location No.	Part No.	Description	Model name	
			P0361WH	MMU-P0481WH
214	43146555	Motor, PMV	1	1
221	43146383	Joint, Check	1	1
222	43146511	PMV	1	
223	43146512	PMV		1
224	43194028	Nut, Flare, 5/8 IN		
225	43194019	Nut, Flare, 3/4 IN	1	1
226	43171022	Socket	1	1
227	43047546	Nut, Flare, 3/8 IN	1	1
228	43194026	Socket	1	1
233	43107215	Holder, Sensor	1	1
234	43047609	Bonnet	1	1
235	43194029	Bonnet		
236	43147451	Bonnet, 3/4 IN	1	1
237	43019822	Holder, Sensor	1	1
240	43150241	Sensor	1	1
241	43158166	Transformer, Power, ST-11227	1	1
242	43149255	Sensor-Pressure	1	1
243	4306A015	Terminal Block, 2P	1	1
244	43150223	Sensor	1	1
245	4316V045	P,C, board Ass'y	1	1
246	43154156	Relay	1	1
247	43160427	Terminal, 5P	1	1
248	43160467	Terminal, 2P	1	1
249	43155079	Capacitor, Electrolytic, 4MFD, 400V		
250	43069864	Sensor	1	1
251	43160468	Fuse	2	2
252	43155099	Capacitor, Electrolytic, 8MFD, 400V AC	1	1

RBC-UW136PG, UW266PG, UW466

TENTATIVE

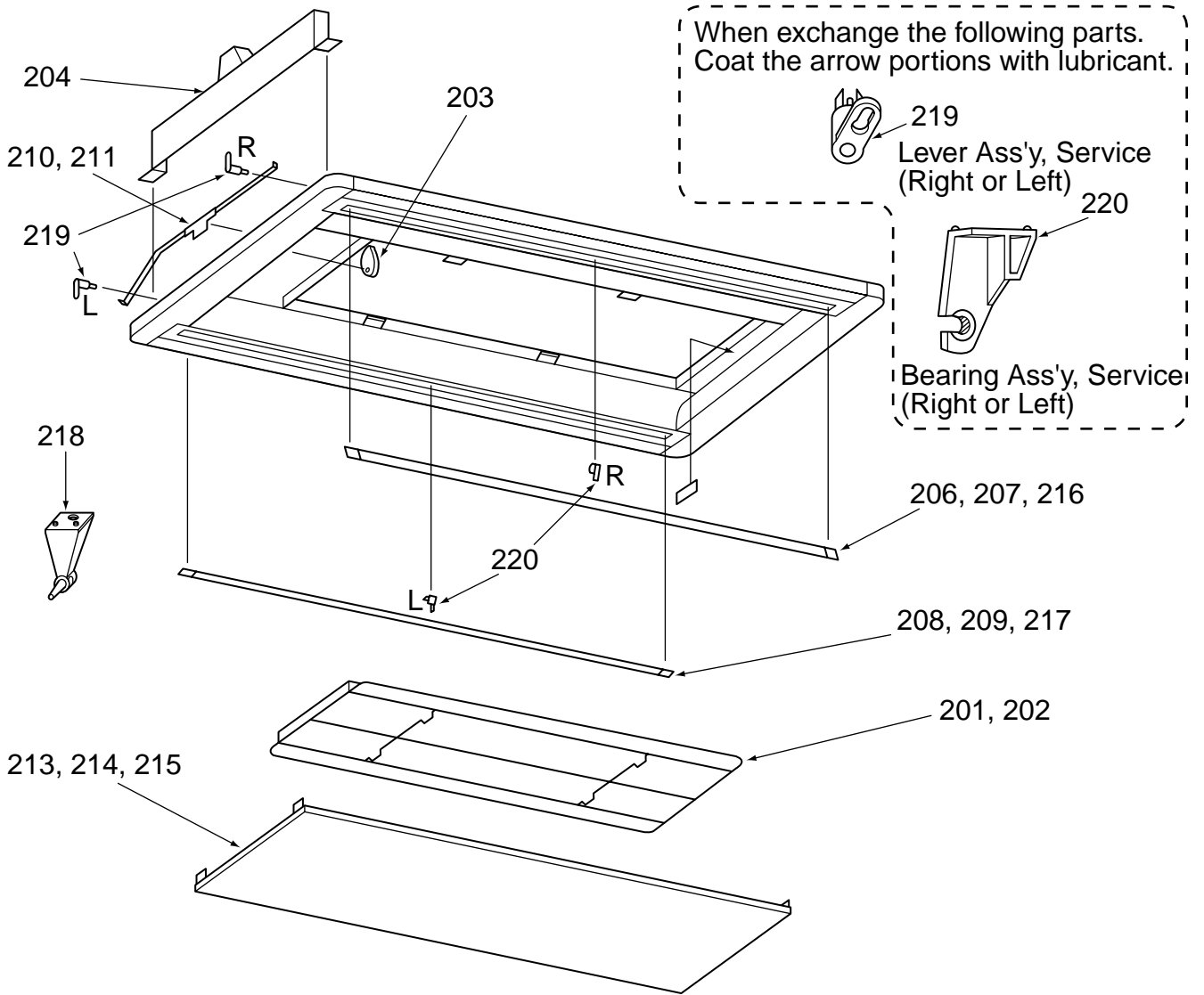

Location No.	Part No.	Description	Model name RBC-		
			UW135PG	UW265PG	UW465PG
201	43480543	Air Filter		2	
202	43480544	Air Filter	1		
203	43121671	Motor, Geard	1	1	1
204	43402625	Motor, Cover	1	1	
206	43409106	Louver Ass'y, Right		1	
207	43409107	Louver Ass'y, Right	1		
208	43409108	Louver Ass'y, Left		1	
209	43409109	Louver Left	1		
210	43407067	Driving Ass'y	1	1	
211	43407096	Driving Ass'y			1
213	43401606	Panel Ass'y, Center		1	
214	43401607	Panel Ass'y, Center	1		
215	43401001	Panel Ass'y, Center			1
216	43409126	Louver Ass'y, Right			1
217	43409127	Louver Ass'y, Left			1
218	43407095	Middle Support Bearing			2
219	43407068	Lever Ass'y, Service	1		1
220	43407069	Bearing Ass'y, Service		1	

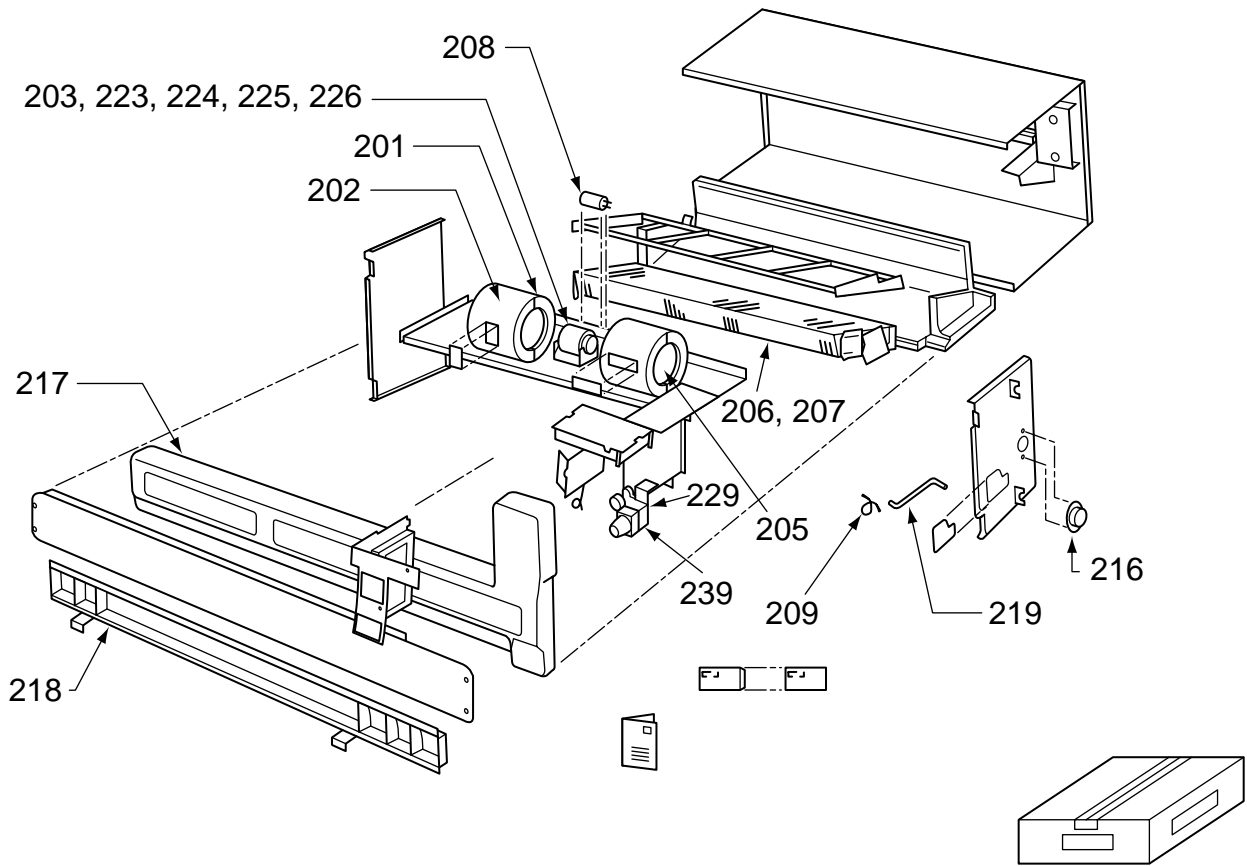

Location No.	Part No.	Description	Model name	
			P0091SH	MMU-P0121SH
201	43039234	Case, Fan, Up	2	2
202	43039235	Case, Fan, Lower	2	2
203	43121546	Motor, Fan	1	1
205	43020226	Fan, Multi Blade	2	2
206	4314J009	Refrigeration cycle Ass'y	1	
207	4314J010	Refrigeration cycle Ass'y		1
208	43255008	Capacitor, Electrolytic, 1.0μF, 450V	1	1
209	43179117	Band, Hose, SUS304-WPB 1.5	1	1
216	43070146	Hose, Drain	1	1
217	43172143	Drain Pan, Inst, Ass'y	1	1
218	43109396	Grille Ass'y, P	1	1
219	43170211	Hose, Drain	1	1
223	43039136	Band, Motor, Left	1	1
224	43039137	Band, Motor, Right	1	1
225	43039238	Band, Motor, Left	1	1
226	43039239	Band, Motor, Right	1	1
229	43151217	Switch, Float	1	1
239	43121683	Drain Dump, Ass'y	1	1

MMU-P0091SH, P0121SH (2)

TENTATIVE

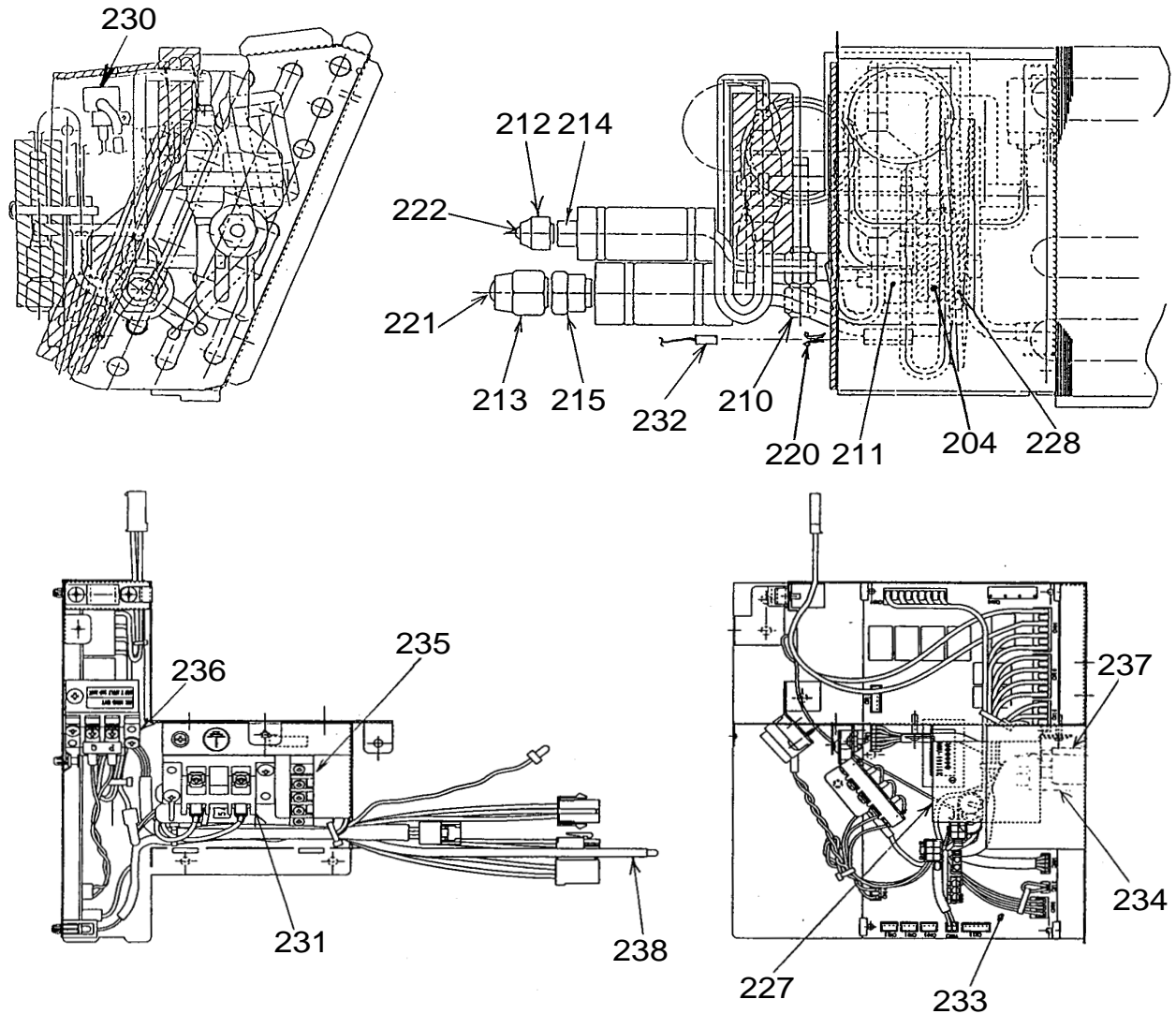

Location No.	Part No.	Description	Model name	
			P0091SH	MMU-P0121SH
204	43146555	Motor, PWV, WDM-MD12TF-3	1	1
210	43146383	Joint, Check	1	1
211	43146510	PMV	1	1
212	43047545	Nut, Flare, 1/4 IN	1	1
213	43194038	Nut, Flare, 1/2 IN	1	1
214	43194051	Socket	1	1
215	43194054	Socket, 1/2 IN	1	1
220	43107215	Holder, Sensor	1	1
221	43147195	Bonnet, 1/2 IN	1	1
222	43049697	Bonnet	1	1
227	43158166	Transformer, Power, ST-11227, AC220V-240V	1	1
228	43150234	Sensor, TC	1	1
230	43149255	Sensor-Pressure	1	1
231	43160516	Terminal, 2P (L, N)	1	1
232	43150236	Sensor	1	1
233	4316V046	P.C. Board Ass'y, MCC-1256	1	1
234	43154156	Relay	1	1
235	43160372	Terminal Block, 3P	1	1
236	43160445	Terminal Block, 2P, AC30V, 1A	1	1
237	43160467	Terminal, 2P, AC250V, 20A	1	1
238	43150200	Sensor, TA	1	1

MMU-P0151SH, P0181SH, P0241SH (1)

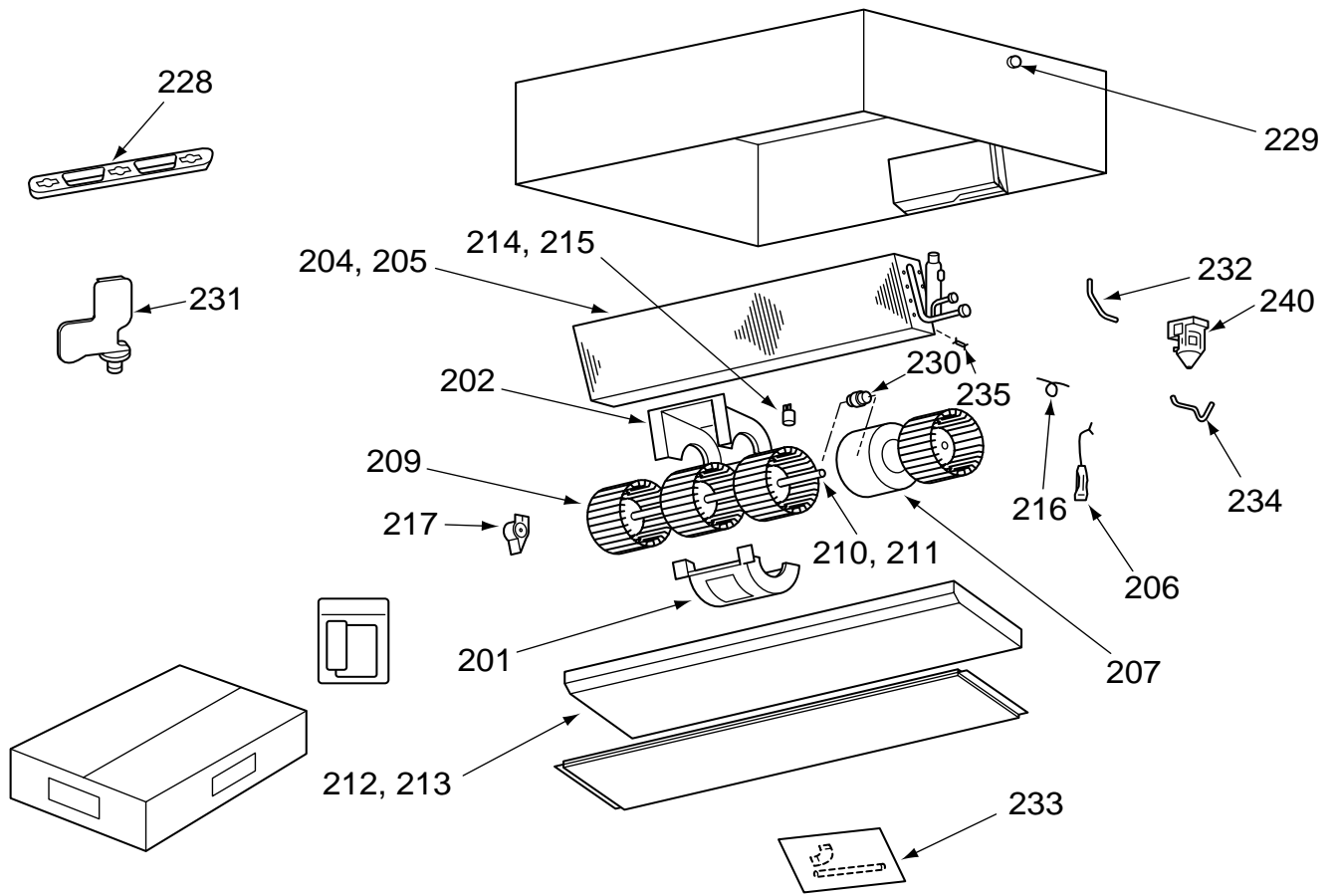

Location No.	Part No.	Description	Model name MMU-		
			P0151SH	P0181SH	P0241SH
201	43126127	Fan, Case, Down	3	3	4
202	43126128	Fan, Case, Upper	3	3	4
203	43144776	Refrigeration Cycle Ass'y	1		
204	43144777	Refrigeration Cycle Ass'y		1	
205	4314J002	Refrigeration Cycle Ass'y			1
206	43151245	Switch, Float	1	1	1
207	43121562	Motor, Fan	1	1	1
208	43146555	Motor, PMV, EDM-MD12TF-3	1	1	1
209	43120172	Fan, S, 125x110L	3	3	4
210	43125141	Shaft			1
211	43125143	Shaft	1	1	
212	43172127	Drain Pan, Ass'y	1	1	
213	43172128	Drain Pan, Ass'y			1
214	43155081	Capacitor, Electrolytic, 2.5μFD,400V			1
215	43155104	Capacitor, Electrolytic, 1.5μFD,400V	1	1	
216	43179117	Band, Hose, SUS304-WPB 1.5	1	1	1
217	43125131	Bearing, Shaft	1	1	1
228	43139098	Rod, Connection	4	4	6
229	43070146	Hose, Drain	1	1	1
230	43125142	Coupling	1	1	1
231	43109339	Grille	14	14	18
232	43170195	Hose, Drain	1	1	1
233	43183017	Accessory Ass'y, B	1	1	1
234	43199065	Hose, Drain	1	1	1
235	43107215	Holder, Sensor	1	1	1
240	43121689	Drain Pump, Ass'y, PJV-05230TF	1	1	1

MMU-P0151SH, P0181SH, P0241SH (2)

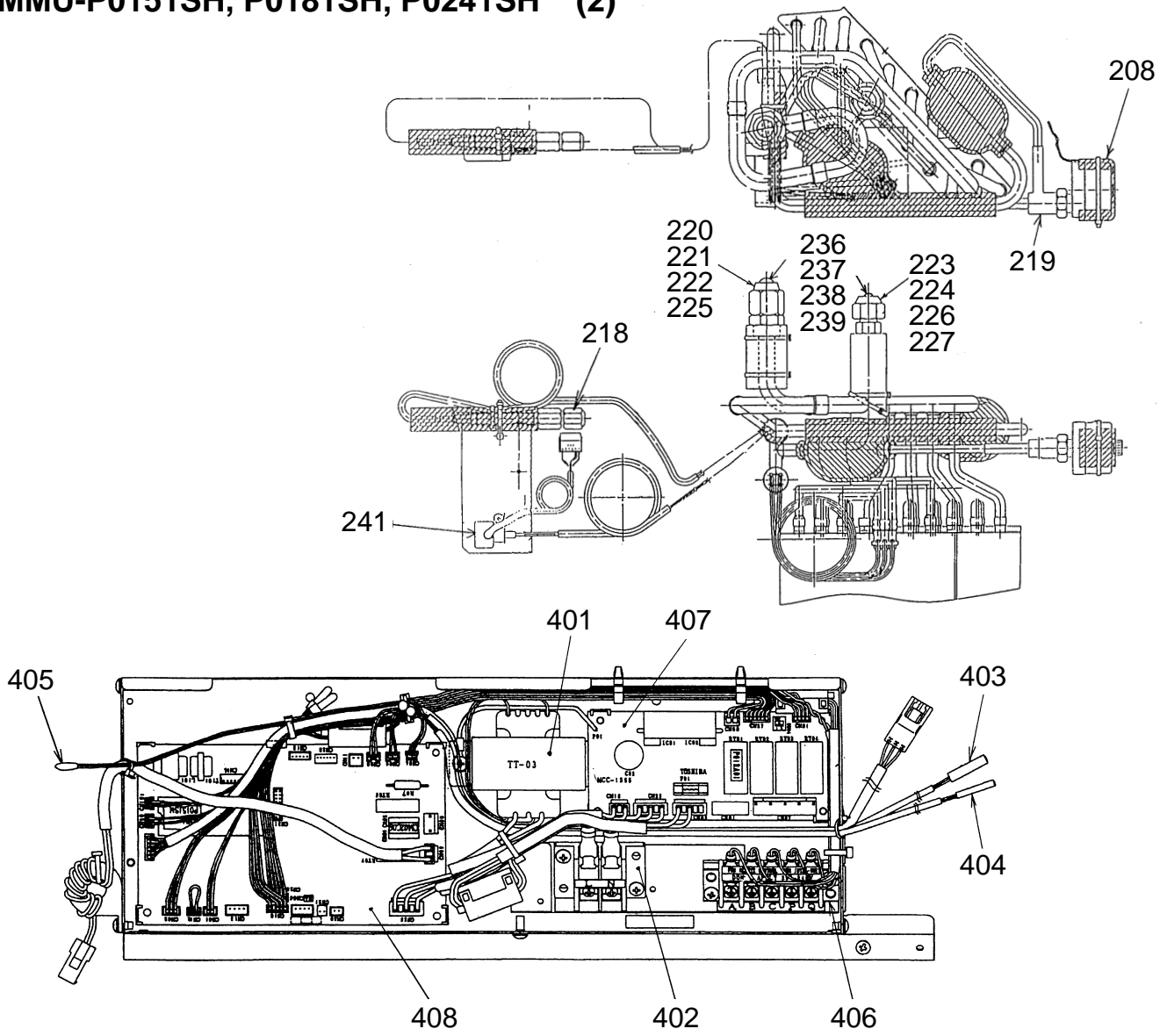

Location No.	Part No.	Description	Model name MMU-		
			P0151SH	P0181SH	P0241SH
218	43146383	Joint, Check	1	1	1
219	43146511	PMV	1	1	1
220	43194028	Nut, Flare, 5/8 IN		1	1
221	43171014	Socket	1		
222	43194065	Socket		1	
223	43047545	Nut, Flare, 1/4 IN	1		
224	43047546	Nut, Flare, 3/8 IN		1	1
225	43194038	Nut, Flare, 1/2 IN	1		
226	43194026	Socket		1	1
227	43194051	Socket	1		
236	43047609	Bonnet		1	1
237	43147195	Bonnet	1		
238	43194029	Bonnet		1	1
239	43149697	Bonnet	1		
241	43149255	Sensor-Pressure	1	1	1
401	43158177	Transformer, Power	1	1	1
402	43160479	Terminal block, 2P	1	1	1
403	43150382	Sensor, TC	1	1	1
404	43150398	Sensor, TG	1	1	1
405	43150400	Sensor, TA	1	1	1
406	43160427	Terminal, 5P	1	1	1
407	4316V162	P.C. Board Ass'y, MCC-1355	1	1	1
408	4316V165	P.C. Board Ass'y, MCC-1361	1	1	1

RBC-UY135PG

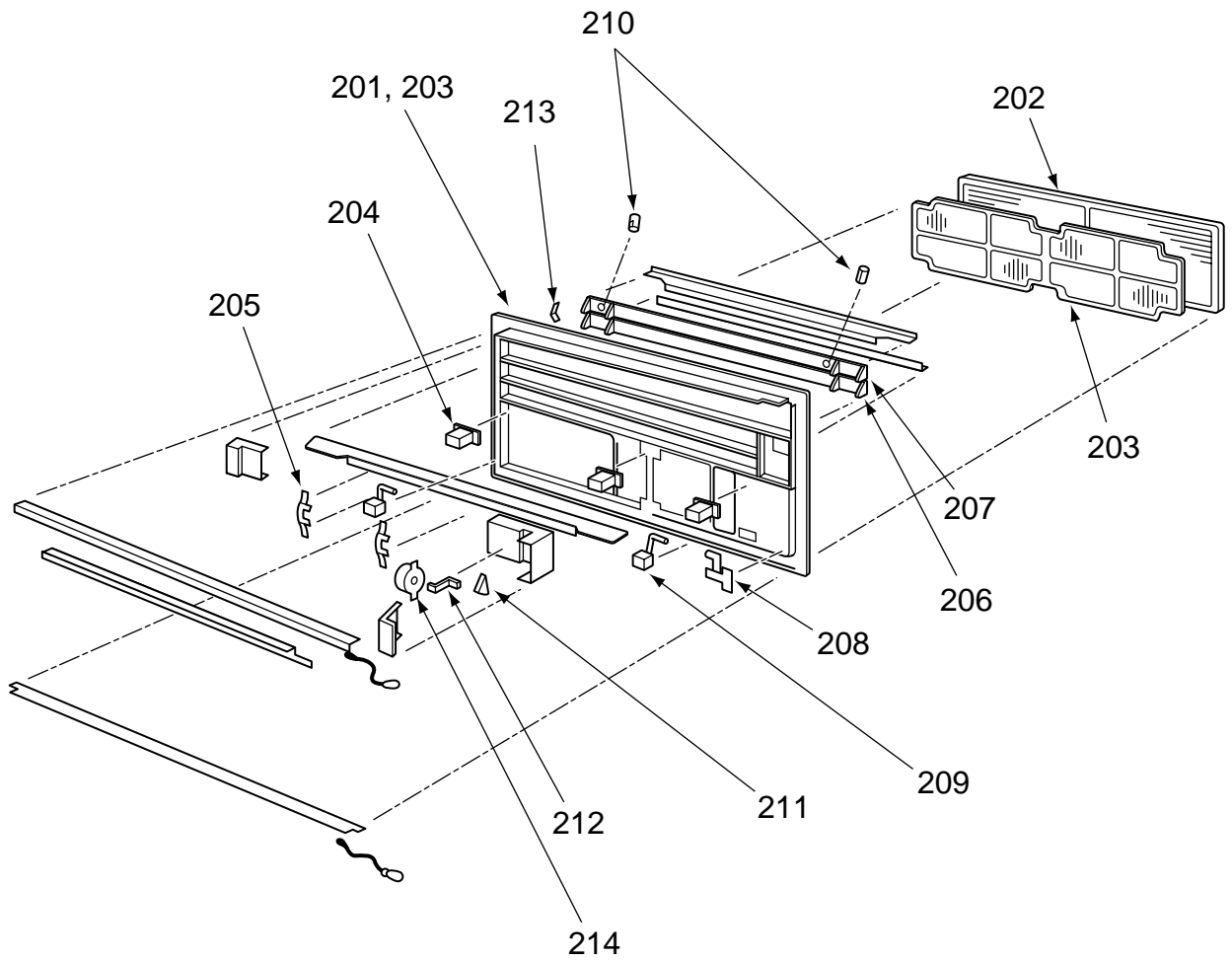

Location No.	Part No.	Description	Model name	RBC-
			UY135PG	
201	43400645	Panel	1	
202	43409080	Grille Ass'y, IN	1	
203	43480529	Air Filter	2	
204	43007408	Latsh	3	
205	43419591	Fix, Ass'y	2	
206	43409082	Grille Ass'y, Pile	1	
207	43409083	Grille Ass'y, Pile	1	
208	43407004	Supporter, Grille, Left	1	
209	43407005	Supporter, Grille, Center	2	
210	43496002	Bush	2	
211	43407020	Link	1	
212	43407021	Lever	1	
213	43407022	Link, C	1	
214	43121625	Motor, Geard, MT8-3-6, 220-240V 50Hz	1	

RBC-US165PG, US265PG

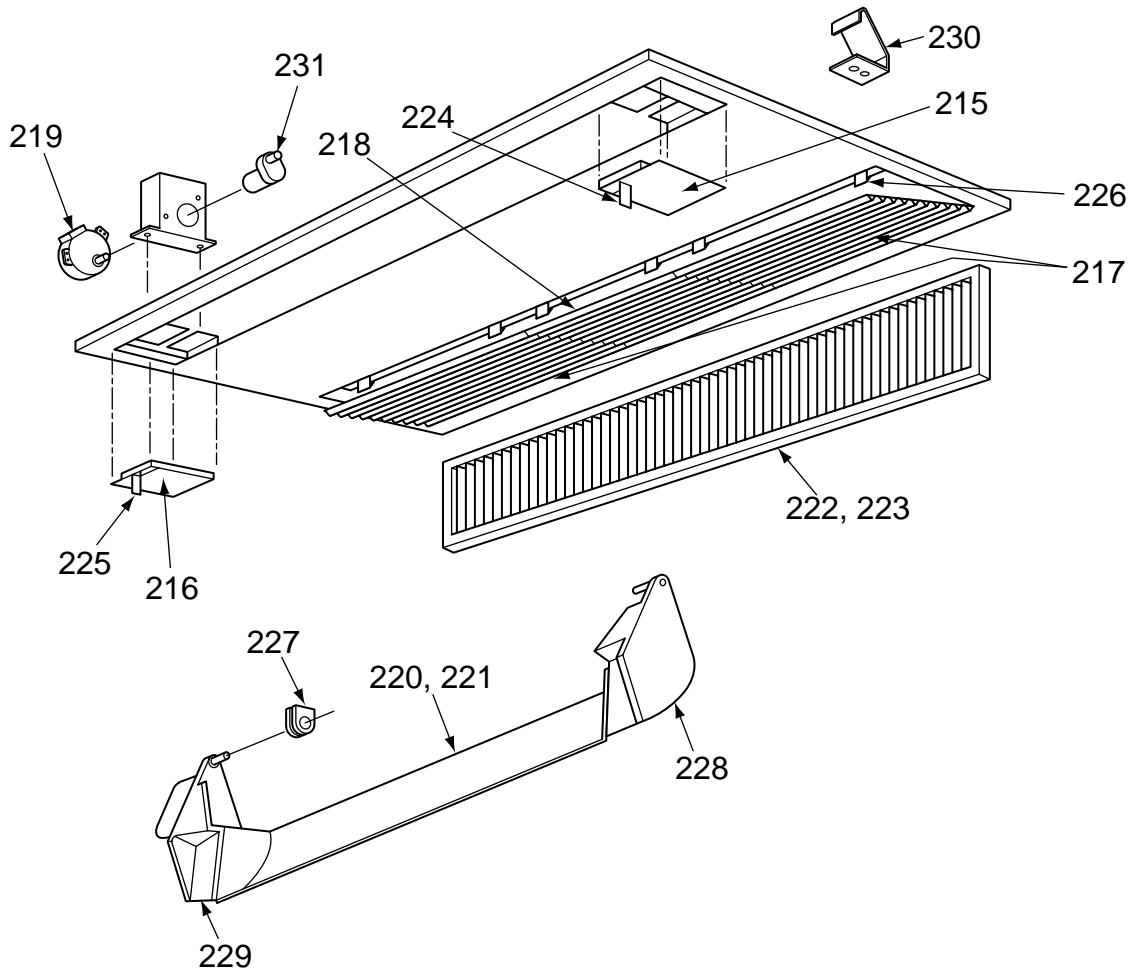

Location No.	Part No.	Description	Model name	
			US165PG	RBC-US265PG
215	43401596	Decoration, Cover Right	1	1
216	43401597	Decoration, Cover Left	1	1
217	43409088	Inlet, Grille, L	1	2
218	43409090	Inlet, Grille, S	2	1
219	43121671	Motor, Geard	1	1
220	43409092	Grille, H	1	
221	43409093	Grille, H		1
222	43119445	Filter, LL	1	
223	43119446	Filter, LL		1
224	43419593	Door, Right	1	1
225	43419594	Door, Light	1	1
226	43407025	Holder	6	6
227	43407027	Holder, S	2	2
228	43407028	Grille, Shaft, Light	1	1
229	43407029	Grille, Shaft, Right	1	1
230	43407030	Hanger	2	2
231	43419592	Lever	1	1

MMD-P0071BH, P0091BH, P0121BH, P0151BH, P0181BH

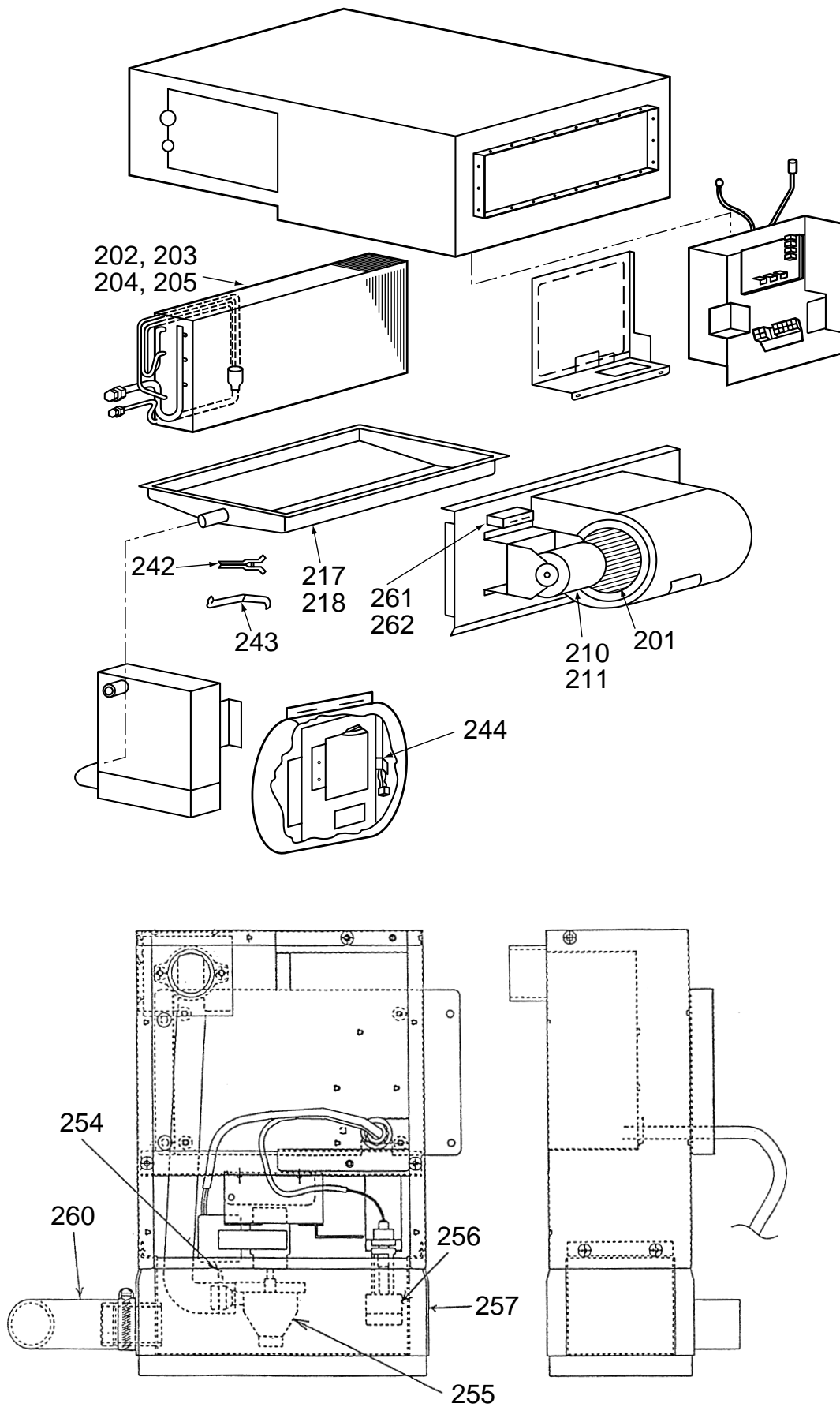

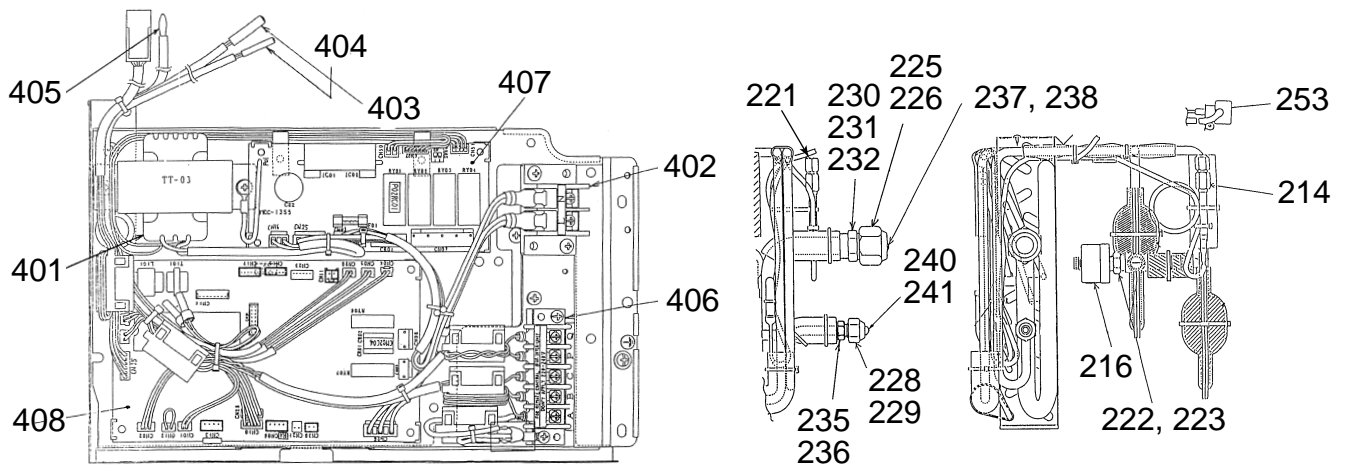

Location No.	Part No.	Description	Model name MMD-				
			P0071BH	P0091BH	P0121BH	P0151BH	P0181BH
201	43120149	Fan, Multi Blade	1	1	1	1	1
202	43144740	Refrigeration Cycle Ass'y	1				
203	43144733	Refrigeration Cycle Ass'y		1	1		
204	43144734	Refrigeration Cycle Ass'y				1	
205	43144735	Refrigeration Cycle Ass'y					1
210	43121644	Motor, Fan	1	1	1		
211	43121643	Motor, Fan				1	1
216	43146555	Motor, PMV, EDM-MD12TF-3	1	1	1	1	1
217	43191306	Drain Ass'y	1	1	1		
218	43191304	Drain Ass'y				1	1
221	43146383	Joint, Check	1	1	1	1	1
222	43146510	PMV, F25	1	1	1		
223	43146511	PMV, F40				1	1
225	43194038	Nut, Flare, 1/2 IN	1	1	1	1	
226	43194028	Nut, Flare, 5/8 IN					1
228	43047545	Nut, Flare, 1/4 IN	1	1	1	1	
229	43047546	Nut, Flare, 3/8 IN					1
230	43194054	Socket, 1/2	1	1	1		
231	43194050	Socket				1	
232	43194065	Socket					1
235	43194051	Socket	1	1	1	1	
236	43194026	Socket					1
237	43147195	Bonnet, 1/2 IN	1	1	1	1	
238	43194029	Bonnet					1
240	43049697	Bonnet	1	1	1	1	
241	43047609	Bonnet					1
242	43107215	Holder, Sensor	1	1	1	1	1
243	43019822	Holder, Sensor, SUS	1	1	1	1	1
244	43160394	Connector, 9P	1	1	1	1	1
253	43149255	Sensor-Pressure, 150F/160NH6-D	1	1	1	1	1
254	43079249	Band, Hose	1	1	1	1	1
255	43121688	Pump, Drain, PJV-05230TF, 220-240V 50/60Hz	1	1	1	1	1
256	43151245	Float, Switch	1	1	1	1	1
257	43172157	Pan, Drain, SUS304	1	1	1	1	1
260	43170225	Hose, Drain, EPT	1	1	1	1	1
261	43155107	Capacitor, 2UF 450V	1	1			
262	43155088	Capacitor, Electrolytic 2.5MFD, 500V, 2.5MF, 500V			1	1	1
401	43158177	Transformer, Power	1	1	1	1	1
402	43160479	Terminal Block, 2P	1	1	1	1	1
403	43050382	Sensor, TC (F6)	1	1	1	1	1
404	43050398	Sensor, TG (F4)	1	1	1	1	1
405	43050402	Sensor, TA, 10K, 25C	1	1	1	1	1
406	43160427	Terminal, 5P	1	1	1	1	1
407	4316V162	P.C. Board Ass'y, (Motor, Tap), MCC-1355	1	1	1	1	1
408	4316V165	P.C. Board Ass'y, (Main, Tap), MCC-1361	1	1	1	1	1

MMD-P0241BH, P0301BH, P0361BH, P0481BH

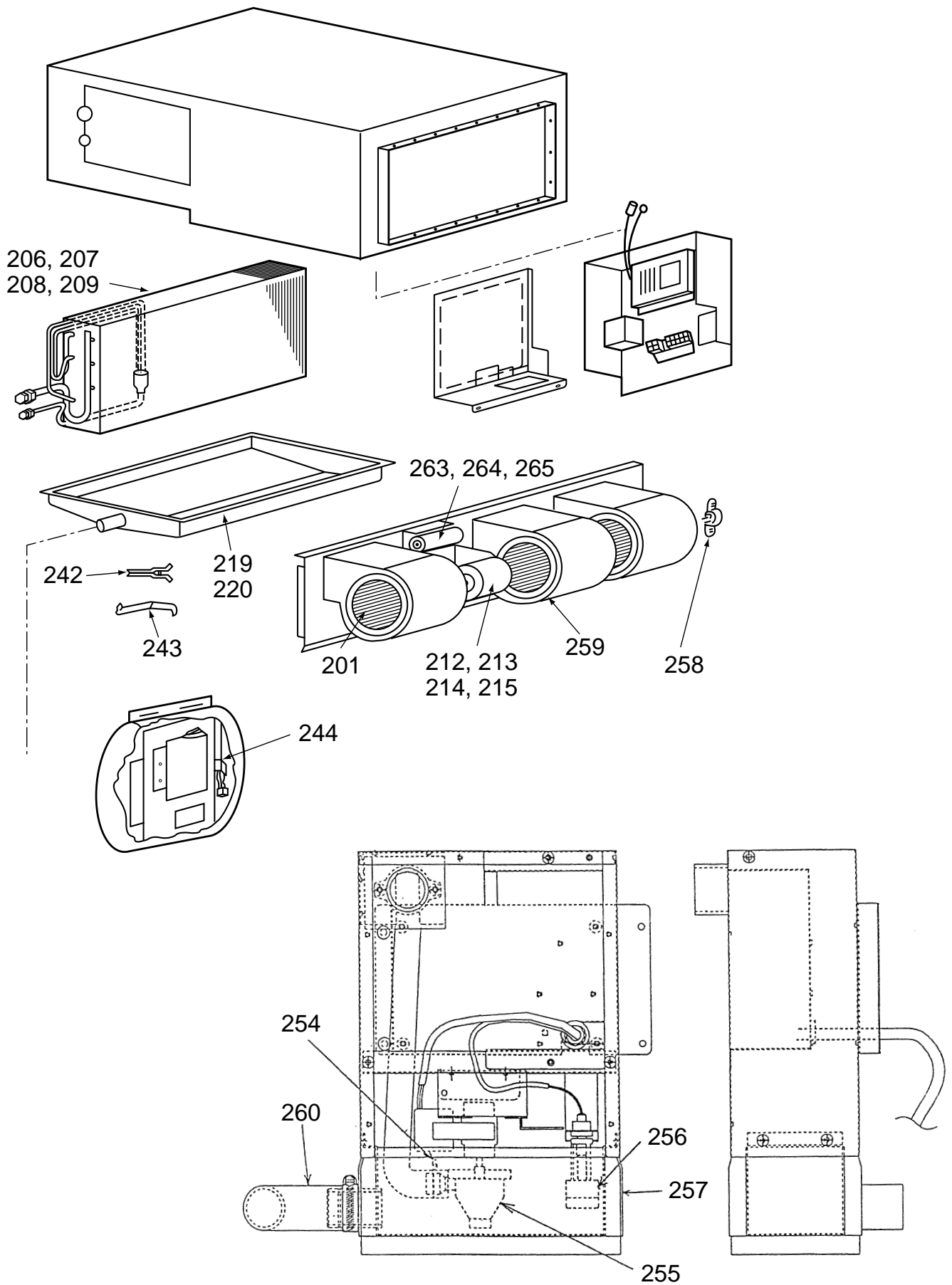

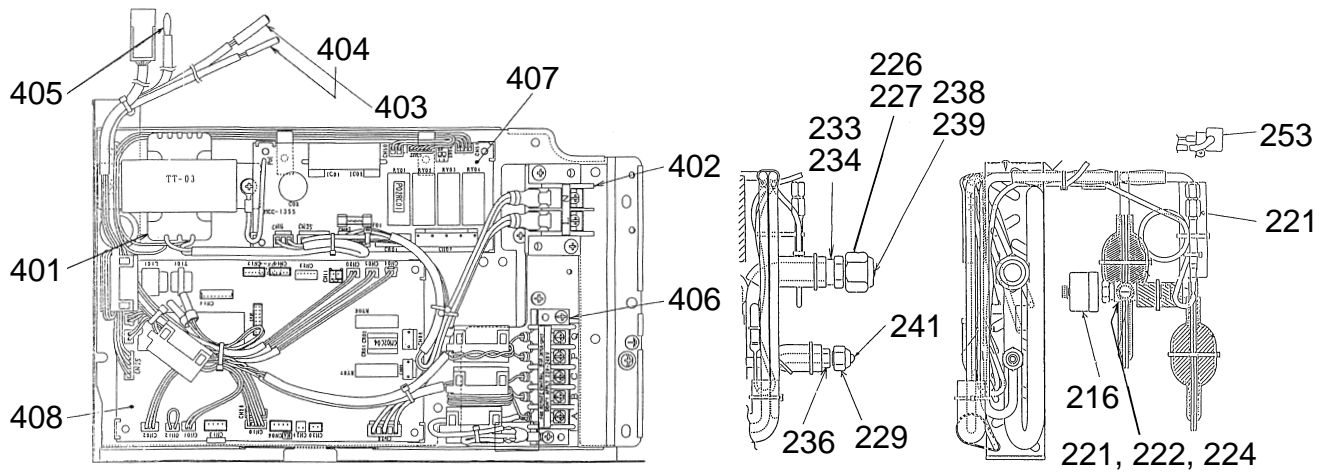

Location No.	Part No.	Description	Model name			
			P0241BH	P0301BH	MMU-P0361H	P0481BH
201	43120149	Fan, Multi blade	2	2	2	3
206	43144736	Refrigeration cycle Ass'y	1			
207	43144737	Refrigeration cycle Ass'y		1		
208	43144738	Refrigeration cycle Ass'y			1	
209	43144739	Refrigeration cycle Ass'y				1
212	43121645	Motor, Fan	1			
213	43121646	Motor, Fan		1		
214	43121647	Motor, Fan			1	
215	43121648	Motor, Fan				1
216	43146555	Motor, PMV	1	1	1	1
219	43191305	Pan, Drain	1			
220	43191310	Pan, Drain		1	1	1
221	43146383	Joint, Check	1	1	1	1
223	43146511	PMV	1	1	1	
224	43146512	PMV				1
226	43194028	Nut, Flare, 5/8 IN	1	1		
227	43194019	Nut, Flare, 3/4 IN			1	1
229	43047546	Nut, Flare, 3/8 IN	1	1	1	1
233	43171043	Socket	1	1		
234	43171022	Socket			1	1
236	43194026	Socket	1	1	1	1
238	43194029	Bonnet	1	1		
239	43147451	Bonnet, 3/4 IN			1	1
241	43047609	Bonnet	1	1	1	1
242	43107215	Holder, Sensor	1	1	1	1
243	43019822	Holder, Sensor	1	1	1	1
244	43160394	Connector, 9P	1	1	1	1
253	43149255	Sensor-Pressure	1	1	1	1
254	43079249	Band, Hose	1	1	1	1
255	43121688	Pump, Drain, PJD-05230TF	1	1	1	1
256	43151245	Float, Switch	1	1	1	1
257	43172157	Pan, Drain	1	1	1	1
258	43125135	Bearing, Shaft				1
259	43125137	Coupling				1
260	43170225	Hose, Drain	1	1	1	1
263	43155096	Capacitor, Electrolytic, 5MFD, 400V	1	1		
264	43155094	Capacitor, Electrolytic			1	
265	43155097	Capacitor, Electrolytic, 10MF, 400V				1
401	43158177	Transformer, Power	1	1	1	1
402	43160479	Terminal Block, 2P	1	1	1	1
403	43050382	Sensor, TC (F6)	1	1	1	1
404	43050398	Sensor, TG (F4)	1	1	1	1
405	43050402	Sensor, TA	1	1	1	1
406	43160427	Terminal, 5P	1	1	1	1
407	4316V162	P.C. Board Ass'y (Motor, Tap)	1	1	1	1
408	4316V165	P.C. Board Ass'y (Main, Tap)	1	1	1	1

MMD-P0151H, P0181H, P0241H, P0361H, P0481H (1)

TENTATIVE

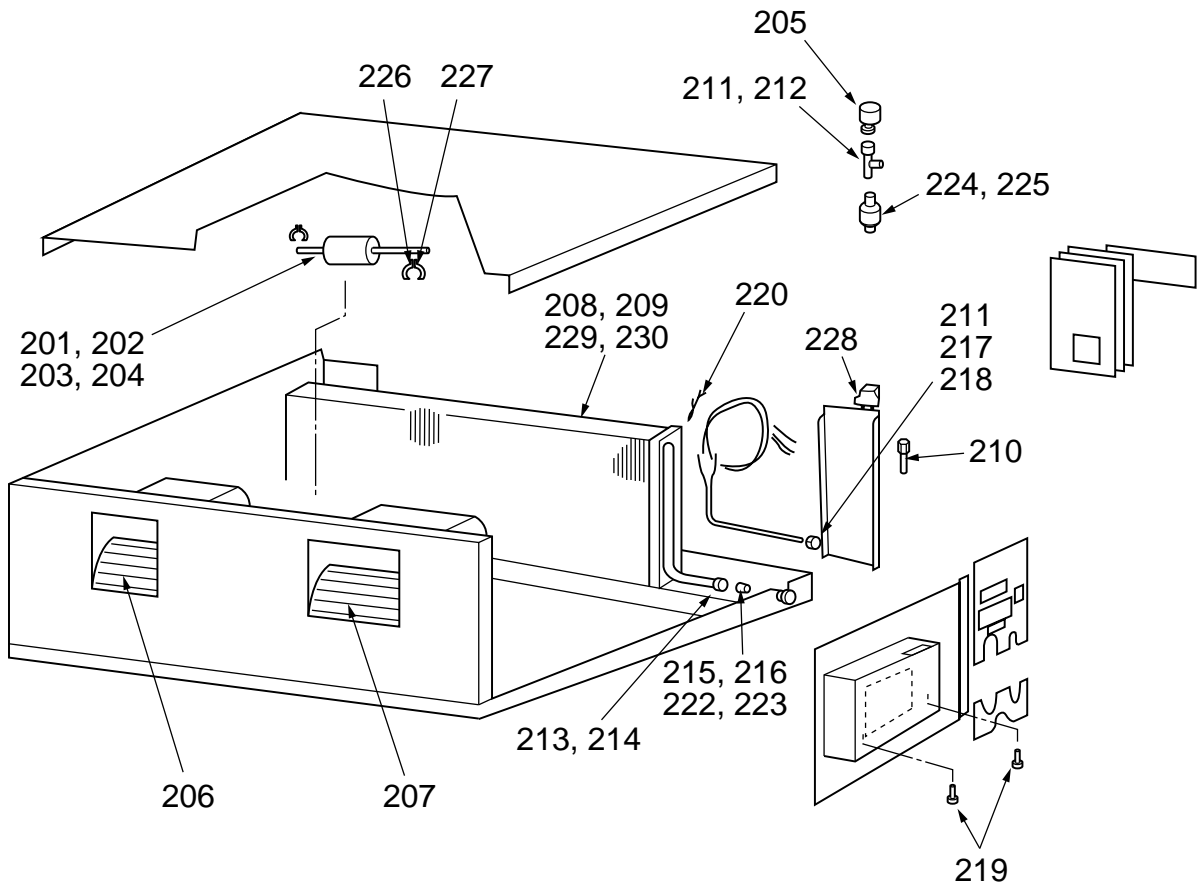

Location No.	Part No.	Description	Model name MMD-				
			P0151H	P0181H	P0241H	P0361H	P0481H
201	43121631	Motor, Fan			1		
202	43121633	Motor, Fan		1			
203	43121628	Motor, Fan					1
204	43121634	Motor, Fan				1	
205	43146555	Motor, PMV		1	1	1	1
206	43120187	Fan		1	1	1	1
207	43120188	Fan				1	1
208	43144725	EVA			1		
209	43144713	EVA		1			
210	43146383	Joint, Check		1	1	1	1
211	43146511	PMV		1	1	1	
212	43146512	PMV					1
213	43194028	Nut, Flare, 5/8 IN		1	1		
214	43194019	Nut, Flare, 3/4 IN				1	1
215	43171043	Socket		1	1		
216	43171022	Socket				1	1
217	43047546	Nut, Flare, 3/8 IN		1	1	1	1
218	43194026	Socket		1	1	1	1
219	43197153	Bolt		2	2	2	2
220	43107215	Holder, Sensor		1	1	1	1
221	43047609	Bonnet		1	1	1	1
222	43194029	Bonnet		1	1		
223	43147451	Bonnet, 3/4 IN				1	1
224	43148041	Strainer				1	1
225	43147558	Strainer		1	1		
226	43039136	Band, Motor, Left		2	2	2	2
227	43039137	Band, Motor, Right		2	2	2	2
228	43149255	Sensor, Pressure		1	1	1	1
229	43144706	EVA				1	
230	43144703	EVA					1

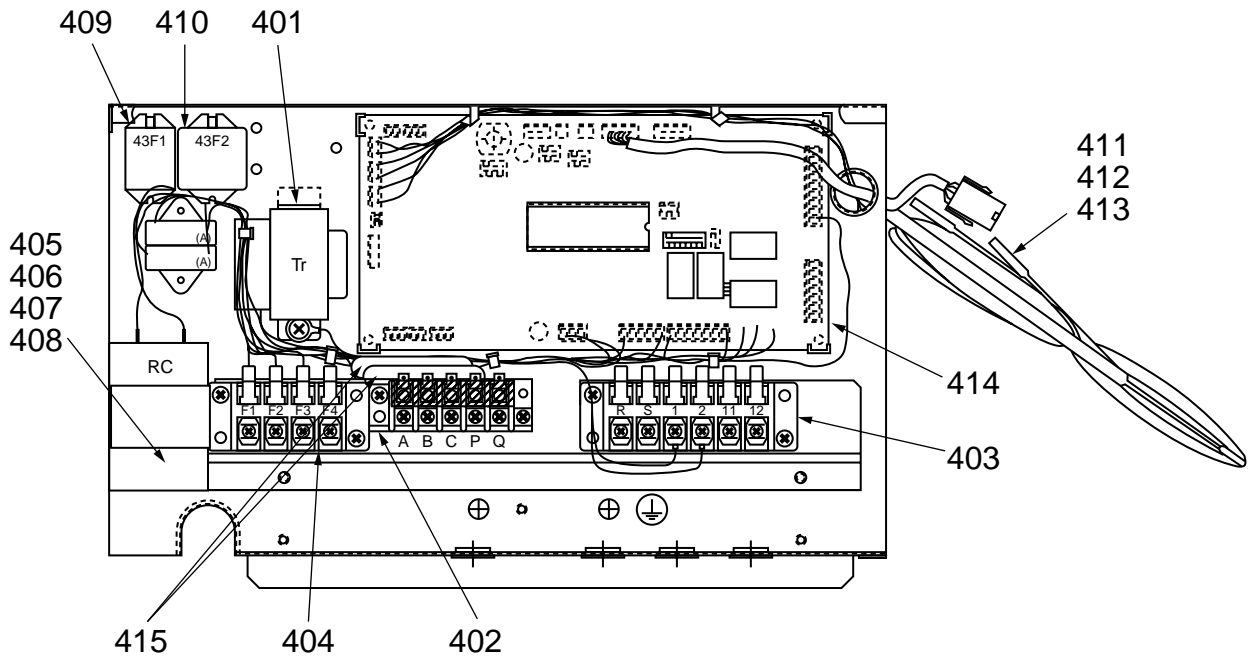

Location No.	Part No.	Description	Model name MMD-				
			P0151H	P0181H	P0241H	P0361H	P0481H
401	43158166	Transformer, Power, ST-11227		1	1	1	1
402	43160427	Terminal, 5P		1	1	1	1
403	43160469	Terminal, Block, 6P		1	1	1	1
404	43160341	Terminal, Block, 4P		1	1	1	1
405	43155164	Capacitor			1		
406	43155142	Capacitor, 4 μ FD, 450V		1			
407	43155137	Capacitor					1
408	43155134	Capacitor, MF, EAG45M605UF1				1	
409	43154141	Relay, LY2F-L, AC230V		1	1	1	1
410	43154135	Relay, LY3F-JT, AC230V		1	1	1	1
411	43150241	Sensor		1	1	1	1
412	43150200	Sensor, TA		1	1	1	1
413	43150223	Sensor		1	1	1	1
414	4316V046	P.C. Board Ass'y		1	1	1	1
415	43060700	Fuse, 10A, 250V		2	2	2	2

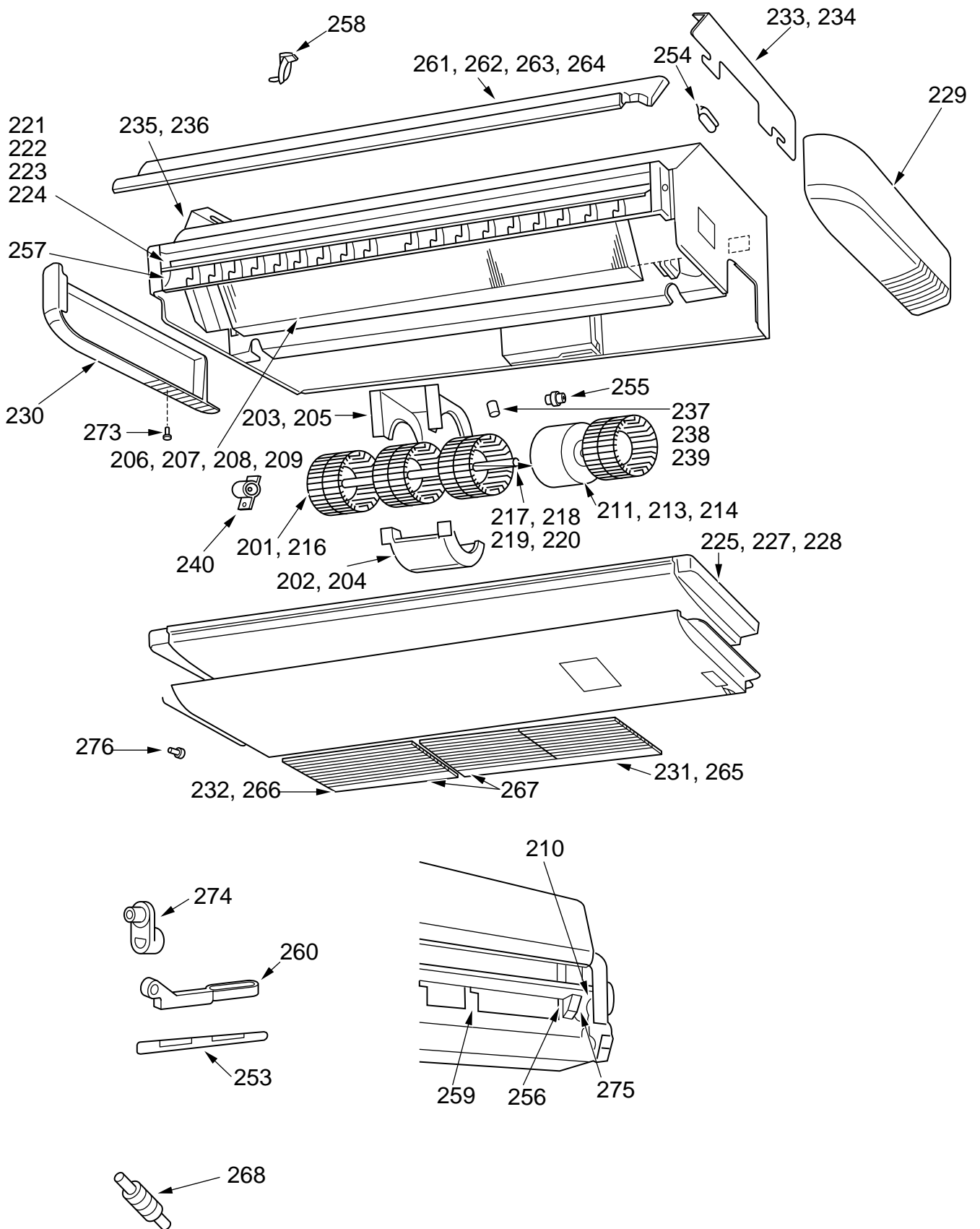

280 : Capacitor, Electrolytic, 1MFD, 450V

TENTATIVE

Location No.	Part No.	Description	Model name MMC-				
			P0151H	P0181H	P0241H	P0361H	P0481H
201	43120174	Fan, Multi Blade				3	4
202	43126127	Fan, Case, Down		3	4		
203	43126128	Fan, Case, Upper		3	4		
204	43126129	Case, Fan, Lower				3	4
205	43216130	Case, Fan, Upper				3	4
206	4314J004	Refrigeration Cycle Ass'y		1			
207	4314J005	Refrigeration Cycle Ass'y			1		
208	4314J006	Refrigeration Cycle Ass'y				1	
209	4314J007	Refrigeration Cycle Ass'y					1
210	43121625	Motor, Geard, MT8-3-6		1	1	1	1
211	43121562	Motor, Fan		1	1		
213	43121573	Motor, Fan				1	
214	43121599	Motor, Fan					1
216	43120172	Fan, S		3	4		
217	43125141	Shaft			1		
218	43125143	Shaft		1			
219	43125144	Shaft, SS					1
220	43125145	Shaft				1	
221	43109324	Grille, Horizon Ass'y		1			
222	43109320	Grille Ass'y, Horizon			1		
223	43109327	Grille Ass'y, Horizon				1	
224	43109328	Grille Ass'y, Horizon					1
225	43172121	Pan Ass'y, Drain		1			
226	43172119	Pan Ass'y, Drain			1		
227	43172122	Pan Ass'y, Drain				1	
228	43172123	Pan Ass'y, Drain					1
229	43102634	Cover Ass'y, Right Side		1	1	1	1
230	43102635	Cover Ass'y, Left Side		1	1	1	1
231	43180307	Air Filter, Small			2	4	6
232	43180308	Air Filter		3	2	1	
233	43193073	Hanger, Right		1	1		
234	43193074	Hanger, Right				1	1
235	43193075	Hanger, Left		1	1		
236	43193076	Hanger, Left				1	1
237	43155102	Capacitor, 1.5μF, 450V				1	
238	43155095	Capacitor, Electrolytic, 2μF, 400V			1		
239	43155093	Capacitor, 2μF, 450V					1
240	43125131	Bearing, Shaft		1	1	1	1
253	43139098	Rod, Connection		5	5	8	6
254	43119373	Cover, Bolt		4	4	4	4
255	43125142	Coupling		1	1	1	1
256	43107222	Shaft, Grille, Right		1	1	1	1
257	43107223	Shaft, Grille, Left		1	1	1	1
258	43107224	Support, Grille Center				1	1
259	43109329	Grille Ass'y, H		15	19	24	26
260	43119393	Holder, Shaft		2	2	3	3
261	43191407	Panel Ass'y, Upper		1			
262	43191408	Panel Ass'y, Upper			1		
263	43191409	Panel Ass'y, Upper				1	
264	43191410	Panel Ass'y, Upper					1
265	43109390	Inlet Ass'y			1	2	3
266	43109391	Inlet Ass'y		3	2	1	
267	43107214	Hinge		6	6	6	6
268	43170197	Hose Ass'y		1	1	1	1
273	43197150	Screw, Coat		4	4	5	5
274	43119394	Lever		1	1	1	1
275	43107216	Spring		1	1	1	1
276	43179107	Plug		1	1	1	1
280	43255008	Capacitor, Electrolytic, 1MFD, 450V		1			

P0151H		
P0181H	278	Please use at Ø2.85 x Ø1.7 x (200L x 2 + 400L x 2)
P0241H	279	Please use at Ø2.85 x Ø1.7 x (200L x 4 + 400L x 2)
P0361H		Please use at Ø2.85 x Ø1.7 x (200L x 7)
P0481H		Please use at Ø2.85 x Ø1.7 x (200L x 5 + 400L x 3)

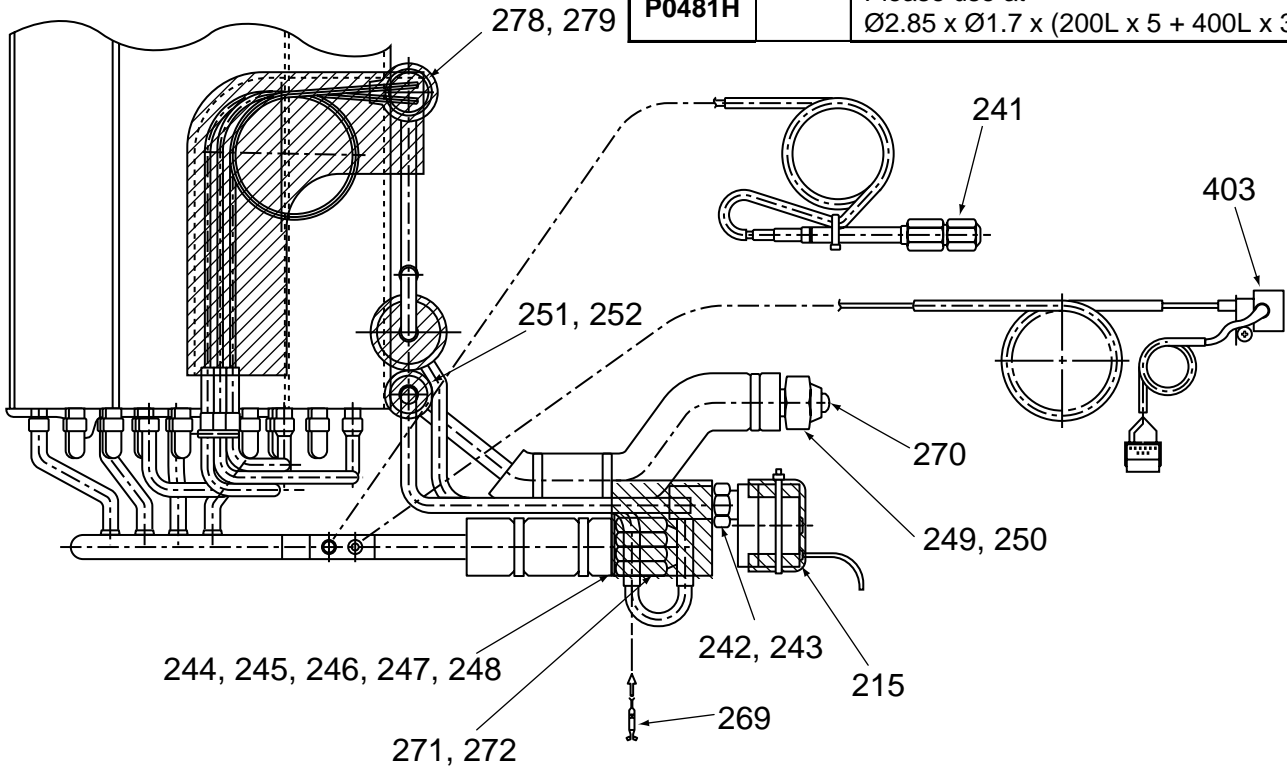

Location No.	Part No.	Description	Model name MMC-				
			P0151H	P0181H	P0241H	P0361H	P0481H
215	43146555	Motor, PMV		1	1	1	1
241	43146383	Joint, Check		1	1	1	1
242	43146511	PMV		1	1	1	
243	43146512	PMV					1
244	43194028	Nut. Flare, 5/8 IN		1	1		
245	43194019	Nut. Flare, 3/4 IN				1	1
246	43171043	Socket			1		
247	43171022	Socket				1	1
248	43194065	Socket	1				
249	43047546	Nut. Flare, 3/8 IN	1	1	1	1	1
250	43194026	Socket	1	1	1	1	1
251	43147565	Strainer		1	1		
252	43148151	Strainer				1	1
269	43107215	Holder, Sensor	2	2	2	2	2
270	43047609	Bonnet	1	1	1	1	1
271	43194029	Bonnet	1	1			
272	43147451	Bonnet, 3/4 IN				1	1
278	43147441	Distributor, ID1.7 x 2000L x 4P		1			
279	43147442	Distributor			1	1	1
403	43149255	Sensor-Pressure		1	1	1	1

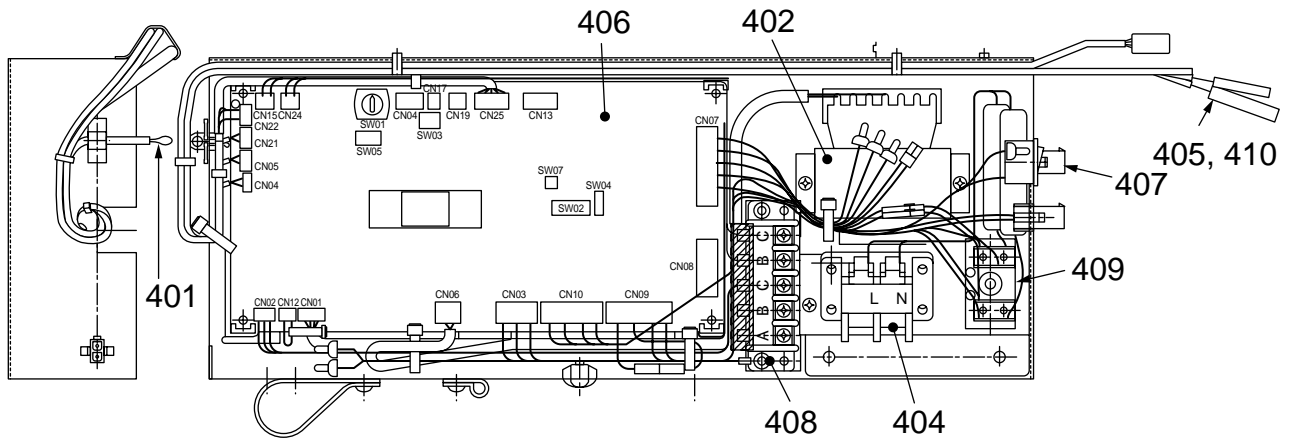

403 : Sensor, Pressure

Location No.	Part No.	Description	Model name MMC-				
			P0151H	P0181H	P0241H	P0361H	P0481H
401	43150200	Sensor, TA		1	1	1	1
402	43158166	Transformer, Power, ST-11227		1	1	1	1
403	43149255	Sensor, Pressure		1	1	1	1
404	43160479	Terminal Block, 2P		1	1	1	1
405	43150236	Sensor		1	1	1	1
406	4316V047	P,C, board Ass'y		1	1	1	1
407	43151226	Selector Switch		1			
408	43160427	Terminal, 5P		1	1	1	1
409	43160467	Terminal, 2P		1	1	1	1
410	43150234	Sensor, TC		1	1	1	1

MMK-P0091H, P0121H, P0151H, P0181H, P0241H

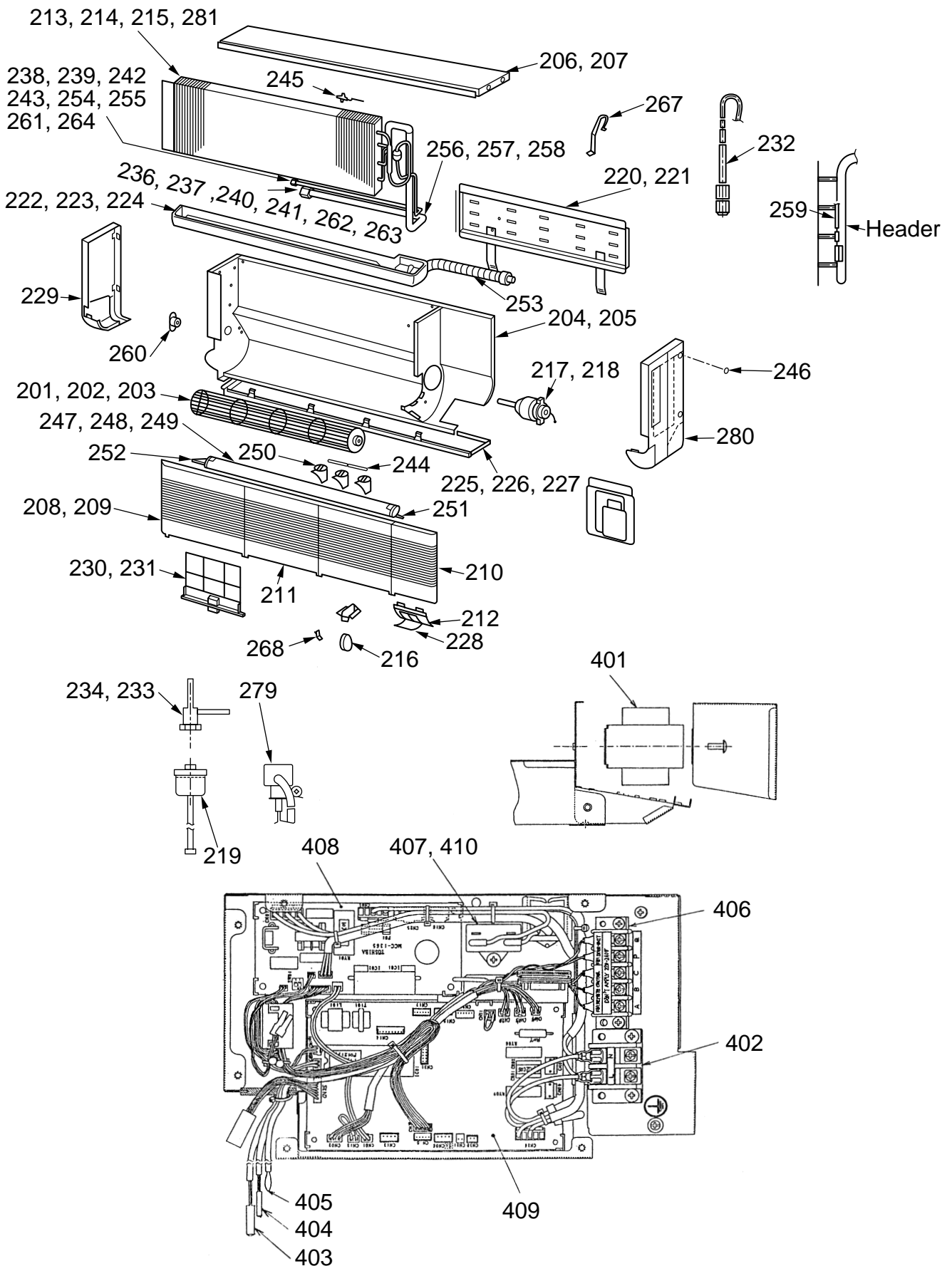

Location No.	Part No.	Description	Model name MMK-				
			P0091H	P0121H	P0151H	P0181H	P0241H
201	43120180	Fan	1	1			
202	43120183	Fan			1	1	
203	43120181	Fan					1
204	43100190	Cabinet Ass'y	1	1			
205	43100191	Cabinet Ass'y			1	1	
206	4319R023	Cabinet, Upper			1	1	
207	4319R024	Cabinet, Upper					1
208	43109343	Grille, Inlet			1	1	2
209	43109353	Grille, Inlet	1	1			
210	43109344	Grille, Inlet Right	1	1	1	1	1
211	43109345	Grille, Inlet Left	1	1	1	1	1
212	43109346	Panel, Receiver	1	1	1	1	1
213	4314J018	Refrigeration Cycle Ass'y	1	1			
214	4314J021	Refrigeration Cycle Ass'y				1	
215	4314J020	Refrigeration Cycle Ass'y					1
216	43121625	Motor, Geard MT8-3-6, 220-240V 50Hz	1	1	1	1	1
217	43121613	Motor, Fan	1	1	1	1	
218	43121614	Motor, Fan					1
219	43146555	Motor, PMV EDM-MD12TF-3	1	1	1	1	1
220	43193066	Plate, Set Ass'y	1	1	1	1	
221	43193067	Plate, Set Ass'y					1
222	43172131	Pan Ass'y, Drain	1	1			
223	43172129	Pan Ass'y, Drain			1	1	
224	43172130	Pan, Drain					1
225	43191389	Cabinet, Plate Lower	1	1			
226	43191387	Cabinet, Plate Lower			1	1	
227	43191388	Cabinet, Lower					1
228	43109347	Cover, Receiver	1	1	1	1	1
229	43102618	Cabinet, Side, Left	1	1	1	1	1
230	43180288	Air Filter	1	1	2	2	3
231	43180289	Air Filter	1	1			
232	43146383	Joint, Check	1	1	1	1	1
233	43146510	PMV, F25	1	1			
234	43146511	PMV, F40			1	1	1
236	43194028	Nut, Flare, 5/8 IN				1	1
237	43171043	Socket, 5/8				1	1
238	43047545	Nut, Flare, 1/4 IN	1	1	1		
239	43047546	Nut, Flare, 3/8 IN				1	1
240	43194038	Nut, Flare, 1/2 IN	1	1	1		
241	43194050	Socket, 1/2	1	1	1		
242	43194063	Socket, 3/8				1	1
243	43194064	Socket, 1/4	1	1	1		
244	43139098	Rod, Connection	3	3	4	4	7
245	43007890	Holder, Sensor TA	1	1	1	1	1
246	43109348	Cover, Screw	4	4	4	4	4
247	43109354	Grille, Horizon	1	1			
248	43109349	Grille, Horizon			1	1	
249	43109350	Grille, Horizontal					1
250	43109359	Grille, Vertical	11	11	14	14	21
251	43109351	Shaft, Grill, Right	1	1	1	1	1
252	43109352	Shaft, Grill, Left	1	1	1	1	1
253	43170209	Hose, Drain	1	1	1	1	1
254	43194072	Liquid Pipe Ass'y	1	1	1		
255	43194073	Liquid Pipe Ass'y				1	1
256	43194074	Gas Pipe Ass'y	1	1	1		
257	43194076	Gas Pipe Ass'y				1	
258	43194075	Gas Pipe Ass'y					1
259	43107215	Holder, Sensor	1	1	1	1	1
260	43022189	Bearing, Steel	1	1	1	1	1
261	43047609	Bonnet, 3/8				1	1
262	43147195	Bonnet, 1/2 IN	1	1	1		
263	43194029	Bonnet, 5/8				1	1
264	43049697	Bonnet, 1/4	1	1	1		
267	43019822	Holder, Sensor	1	1	1	1	1
268	43119394	Lever	1	1	1	1	1
279	43149255	Sensor-Pressure, 150F/160NH6-D	1	1	1	1	1
280	43102617	Cabinet, Side, Right PS-HIS	1	1	1	1	1
281	4314J019	Refrigeration Cycle Ass'y			1		
401	43158177	Transformer, Power, TT-03	1	1	1	1	1
402	43160479	Terminal Block, 2P	1	1	1	1	1
403	43050382	Sensor, TC (F6)	1	1	1	1	1
404	43050398	Sensor, TG (F4)	1	1	1	1	1
405	43050402	Sensor, TA	1	1	1	1	1
406	43160427	Terminal, 5P	1	1	1	1	1
407	43155179	Capacitor, 1.5MFD, 450V			1	1	1
408	4316V163	P.C. Board Ass'y (Motor, Phase), MCC-1365	1	1	1	1	1
409	4316V166	P.C. Board Ass'y (Main, Phase), MCC-1361	1	1	1	1	1
410	43155178	Capacitor, 1MFD, 400V	1	1			

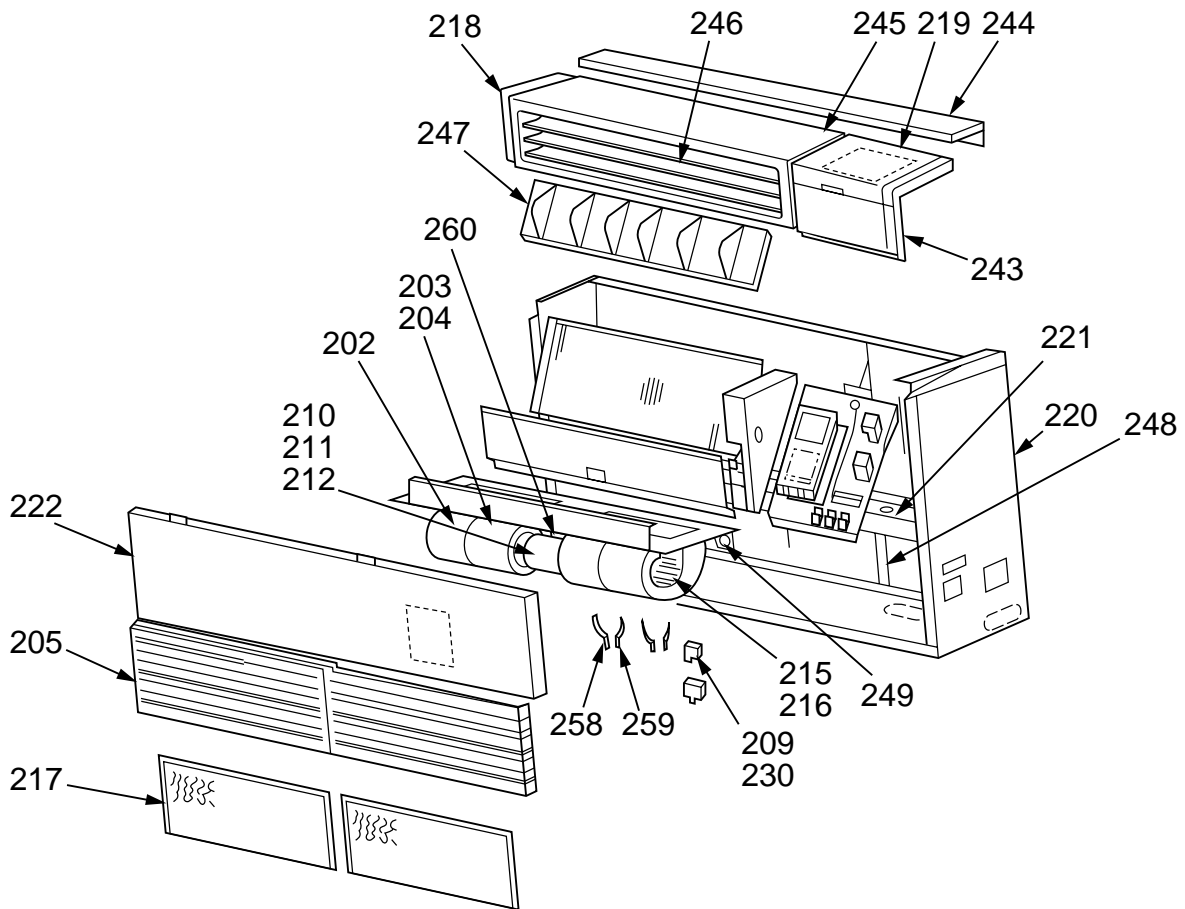

Location No.	Part No.	Description	Model name MML-			
			P0091H	P0151H	P0181H	P0241H
202	43723020	Case, Fan, Left	2		2	2
203	43723019	Case, Fan, Right	2		2	
204	43126119	Case, Fan, Right				2
205	43109394	Grille, Inlet, White	2		2	2
209	43155171	Capacitor			1	1
210	43121299	Motor, Fan, Single, Phase, 45W			1	
211	43121300	Motor, Fan, Single, Phase, 70W				1
212	43121641	Motor, Fan	1			
215	43120074	Fan, Multi, Blade, 140x160MM	2		2	
216	43120137	Fan, Multi Blade, 140x200				2
217	43180280	Air Filter, Mildew, Proof	2		2	2
218	43101323	Frame, White	1		1	1
219	43101325	Cover, Control Panel, White	1		1	1
220	43121299	Case Ass'y	1		1	1
221	43172101	Pan, Drain	1		1	1
222	43100225	Panel, Front, White	1		1	1
230	43155109	Capacitor, Electrolytic, 1.5μFD, 450V	1			
243	43101338	SW BOX, Ass'y	1		1	1
244	43100145	Cabinet, Upper, White	1		1	1
245	43100147	Outlet, White	1		1	1
246	43109316	Grille, White	3		3	3
247	43109240	Grille	1		1	1
248	43170201	Hose, Drain	1		1	1
249	43022347	Flange, Nut	1		1	1
258	43039136	Band, Motor, Left	2		2	2
259	43039137	Band, Motor, Right	2		2	2
260	43191079	Base, Motor	1		1	1

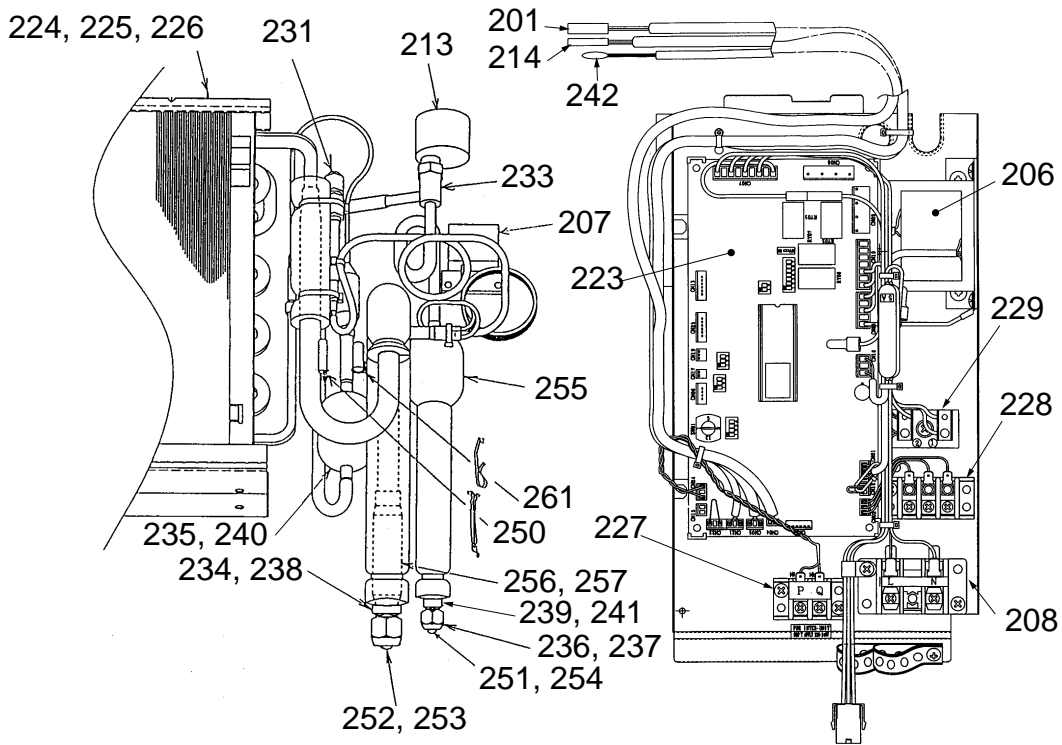

Location No.	Part No.	Description	Model name MML-			
			P0091H	P0151H	P0181H	P0241H
201	43150241	Sensor	1		1	1
206	43158166	Transformer, Power, ST-11227, AC220V-240V	1		1	1
207	43149255	Sensor, Pressure, 150F/160NH-D	1		1	1
208	4306A015	Terminal Block, 2P, AC250V, 20A	1		1	1
213	43146555	Motor, PMV, EDM-MD12TF-3	1		1	1
214	43150222	Sensor	1		1	1
223	4316V047	P.C. Board, Ass'y, MMC-1256	1		1	1
224	43144742	Refrigeration Cycle, Ass'y	1			
225	43144744	Refrigeration Cycle, Ass'y				1
226	4314J082	Refrigeration Cycle, Ass'y			1	
227	43160445	Terminal Block, 2P, AC3V, 1A	1		1	1
228	43160457	Terminal, 3P	1		1	1
229	43160467	Terminal, 2P, AC250V, 20A	1		1	1
231	43146383	Joint, Check	1		1	1
232	43146510	PMV	1			
233	43146511	PMV			1	1
234	43194028	Nut, Flare, 5/8 IN			1	1
235	43171043	Socket			1	1
236	43047545	Nut, Flare, 1/4 IN	1			
237	43047546	Nut, Flare, 3/8 IN			1	1
238	43194038	Nut, Frare, 1/2 IN	1			
239	43194026	Socket			1	1
240	43194050	Socket	1			
241	43194051	Socket	1			
242	43150197	Sensor, TA	1		1	1
250	43107215	Holder, Sensor	1		1	1
251	43047609	Bonnet			1	1
252	43147195	Bonnet, 1/2 IN	1			
253	43194029	Bonnet			1	1
254	43049697	Bonnet	1			
255	43147558	Strainer	1		1	1
256	43148079	Strainer			1	1
257	43148080	Strainer	1			
261	43019822	Holder, Sensor	1		1	1

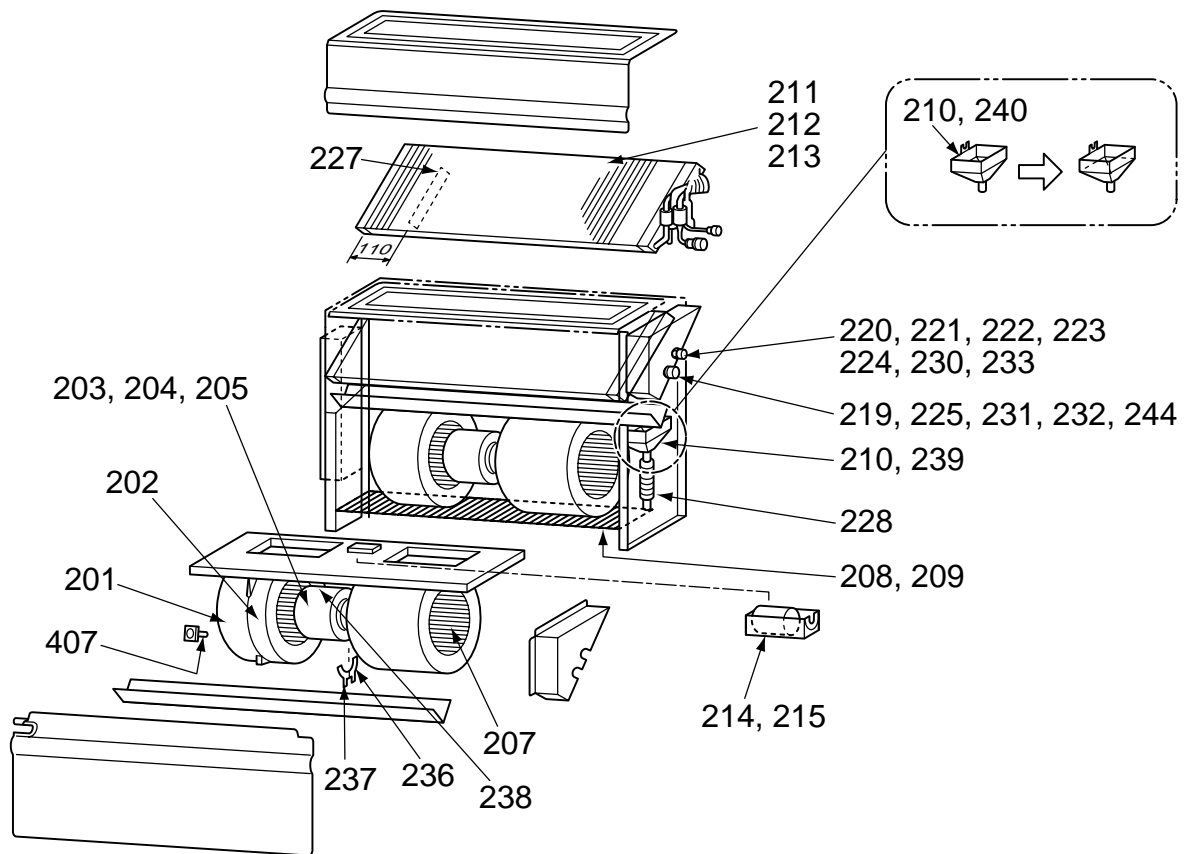

Location No.	Part No.	Description	Model name			
			P0091BH	P0151BH	P0181BH	P0241BH
201	43723020	Case, Fan, Left	1		2	2
202	43126119	Case, Fan, Right	1		2	2
203	43121299	Motor, Fan, Single Phase 45W			1	
204	43121300	Motor, Fan, Single Phase 70W				1
205	43121642	Motor, Fan	1			
207	43120137	Fan, Multi Blade, 140x200	1		2	2
208	43180294	Filter	1			
209	43180295	Filter			1	1
210	43170206	Catch, Drain	1		1	1
211	43144748	Evaporator, Ass'y	1			
212	43144751	Evaporator, Ass'y			1	
213	43144752	Evaporator, Ass'y				1
214	43255008	Capacitor, Electrolytic, 1.0µF			1	
215	43155093	Capacitor, 2µF, 450V				1
219	43194028	Nut, Flare, 5/8 IN			1	1
220	43047545	Nut, Flare, 1/4 IN	1			
221	43047546	Nut, Flare, 3/8 IN			1	1
222	43194038	Nut, Flare, 1/2 IN	1			
223	43194026	Socket			1	1
224	43194077	Socket, 1/8 IN	1			
225	43194054	Socket, 1/2 IN	1			
227	43122046	Plate, Wind	2			
228	43170197	Hose Ass'y,	1		1	1
230	43047609	Bonnet			1	1
231	43147195	Bonnet, 1/2 IN	1			
232	43194029	Bonnet			1	1
233	43049697	Bonnet	1			
236	43039136	Band, Motor, Left	2		2	2
237	43039137	Band, Motor, Right	2		2	2
238	43191079	Base, Motor	1		1	1
239	43170207	Strainer	1		1	1
240	43111311	Hins	1		1	1
244	43171043	Socket			1	1
407	43150200	Sensor, TA	1		1	1

MML-P0091BH, P0151BH, P0181BH, P0241BH (2)

TENTATIVE

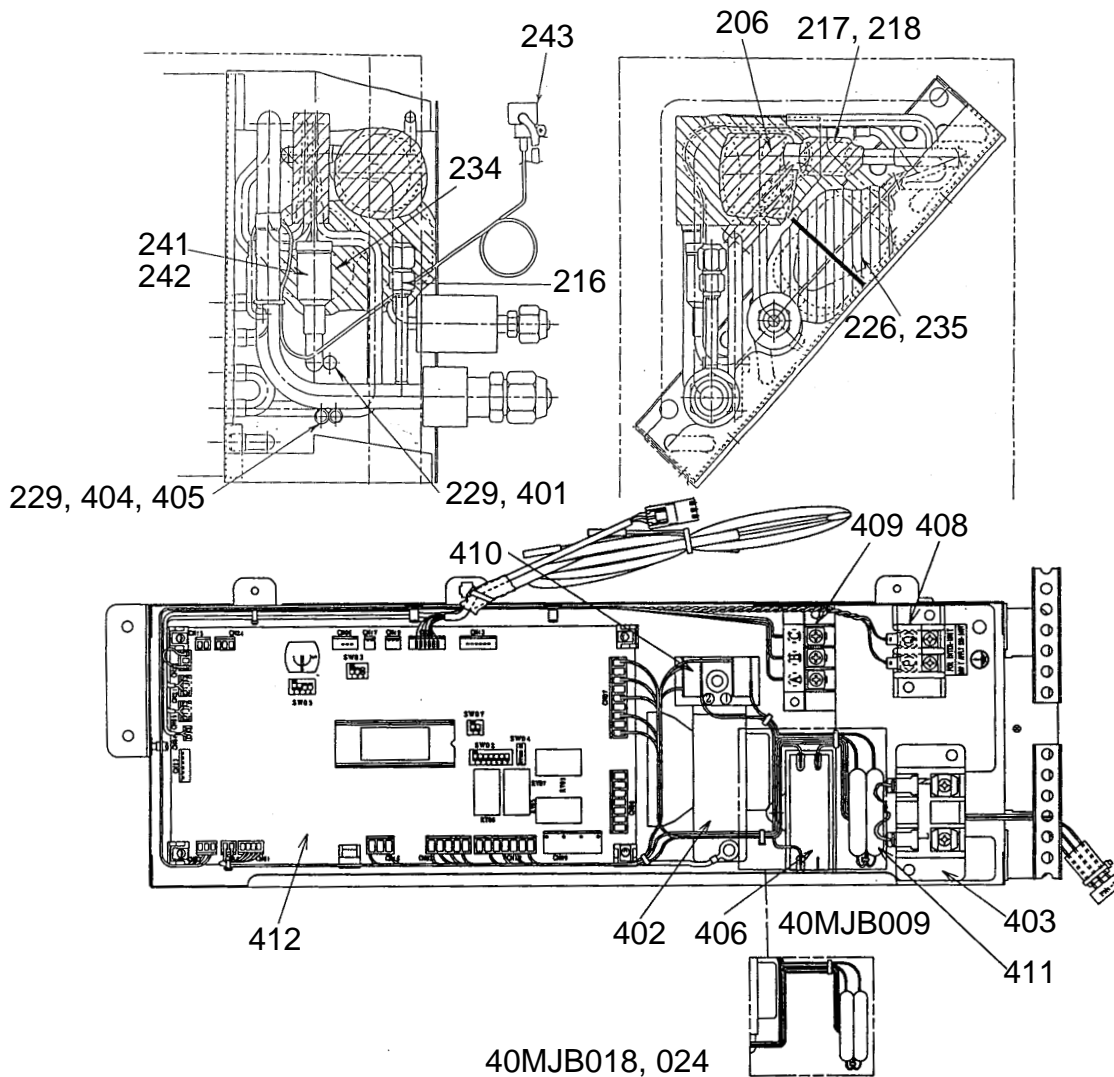

Location No.	Part No.	Description	Model name MML-			
			P0091BH	P0151BH	P0181BH	P0241BH
206	43146555	Motor, PMV, EDM-MD12TF-3	1		1	1
216	43146383	Joint, Check	1		1	1
217	43146510	PMV, F25	1			
218	43146511	PMV, F40			1	1
226	43147565	Strainer				1
229	43107215	Holder, Sensor	2		2	2
234	43148041	Strainer	1		1	1
235	43147558	Strainer	1		1	
241	43147511	Distributor, Ass'y, Ø2.0x200L cut			1	1
242	43047527	Tube, Capillary, ID 2.0X2000L	1			
243	43149255	Sensor-Pressure	1		1	1
401	43150234	Sensor, TC	1		1	1
402	43158166	Transformer, Power, ST-1, AC220V-240V	1		1	1
403	4306A015	Terminal Block, 2P, AC250V, 20A	1		1	1
404	43150223	Sensor	1			
405	43150222	Sensor			1	1
406	43155109	Capacitor, Electrolytic, 1.5µFD, 450V	1			
408	43160445	Terminal Block, 2P, AC30V, 1A	1		1	1
409	43160457	Terminal, 3P	1		1	1
410	43160467	Terminal, 2P, AC250V, 20A	1		1	1
411	43160468	Fuse, 250V, 5A	2		2	2
412	4316V047	P.C.Board Ass'y, MCC-1256	1		1	1

<Cooling Only model>

MMY-MP0801T8, MP1001T8
 MMY-MP08018, MP10018

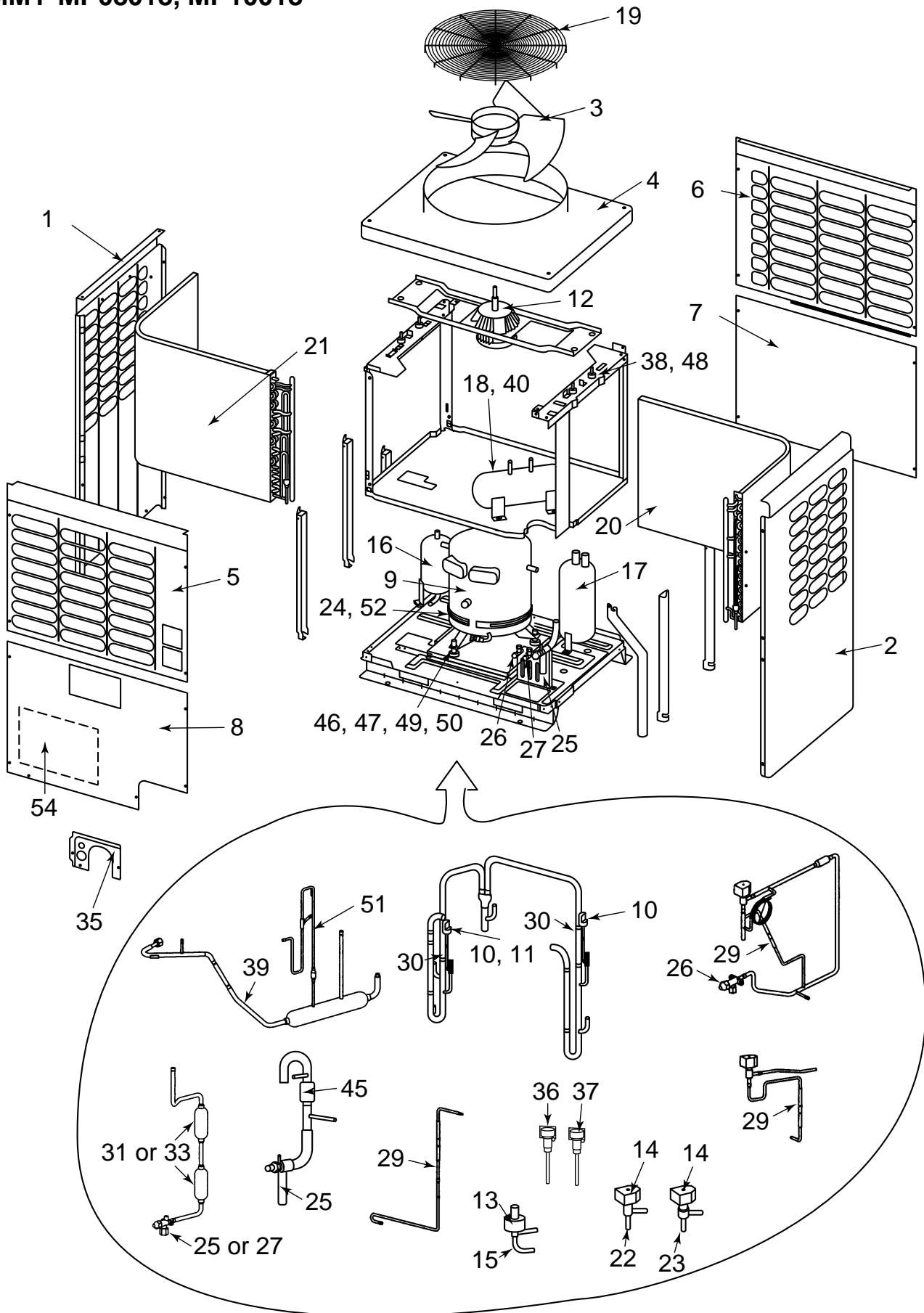

Location No.	Part No.	Description	Model name MMY-			
			PM0801T8	PM1001T8	PM08018	PM10018
1	43191594	Cabinet, Side Left	1	1	1	1
2	43191595	Cabinet, Side Right	1	1	1	1
3	43120203	Fan, Propeller DIA 630	1	1	1	1
4	43100209	Cabinet, UP	1	1	1	1
5	43191596	Cabinet, Front UP	1	1	1	1
6	43191597	Cabinet, Back UP	1	1	1	1
7	43191598	Cabinet, Back Down	1	1	1	1
8	43191599	Cabinet, Front Down	1	1	1	1
9	43141613	Compressor, HV1360CW-Y12B		1		
9	43141614	Compressor, HV1201CW-Y12B	1			
9	43141709	Compressor, YH1240CW-B				1
9	43141710	Compressor, YH1201CW-B			1	
10	43151229	Switch, High Pressure 20PS	1	1	2	2
11	43151243	Switch, High Pressure ACB-JBD8	1	1		
12	43121679	Motor, Fan STF-200-350A	1	1	1	1
13	43146573	Coil, Pulse Motor Valve A12A15	1	1	1	1
14	43146548	Coil, Solenoid NEV-MOAJ510B0	5	5	6	6
15	43046377	Valve, Pulse Modulating, SEV18RC4	1	1	1	1
16	43148134	Separator, Oil	1	1	1	1
17	43148152	Accumulator	1	1	1	1
18	43148141	Tank, Liquid	1	1		
18	43148144	Tank, Liquid			1	1
19	43119444	Guard, Fan	1	1	1	1
20	4314G085	Condenser Ass'y	1	1	1	1
21	4314G086	Condenser Ass'y	1	1	1	1
22	43046151	Valve, 2-Way NEV202DXF	3	3	4	4
23	43046270	Valve, 2-Way NEV603DXF	2	2	2	2
24	43157254	Heater, Crank Case			1	1
25	43146351	Valve, Service	1	1	1	1
26	43046115	Valve, Packed 3/8 IN, 9.5DIA	1	1	1	1
27	43146378	Valve, Packed 1/2 IN	1	1	1	1
28	43146383	Joint, Check	2	2	2	2
29	43046313	Valve, Checked BCV-302DXA30	3	3	3	3
30	43146495	Valve, Checked BCV-804DY	2	2	3	3
31	43047546	Nut, Flare 3/8 IN	1	1	1	1
32	43194077	Socket, 1/8 IN	2	2	2	2
33	43145079	Dryer	1	1	1	1
34	43148151	Strainer	1	1	1	1
35	43191600	Panel, CGCD2-Z08-C77	1	1	1	1
36	43149276	Sensor Ass'y, Low Pressure 150NH4-L	1	1	1	1
37	43149277	Sensor Ass'y, High Pressure 150NH4-H	1	1	1	1
38	43097204	Nut	4	4	4	4
39	43146283	Valve, Checked YCV5-3S-TF	2	2	2	2
40	43048009	Plug, Fusible	1	1	1	1
41	43147196	Bonnet, 1/4 IN 6.4	2	2	2	2
42	44246236	Tube, Capillary Bypass, 1.0x2.0x110L	1	1	1	1
43	44246239	Tube, Capillary ID 1.2	1	1	1	1
44	43047527	Tube, Capillary ID 2.0x2000L	1	1	1	1
45	43147529	Strainer	1	1	1	1
46	43195185	Cushion, Under Compressor	3	3	3	3
47	43195186	Cushion, Under Compressor	3	3	3	3
48	43049643	Cushion, Rubber	4	4	4	4
49	43107200	Base, Spring	3	3	3	3
50	43195198	Spacer	3	3	3	3
51	43047585	Strainer, Copper	3	3	3	3
52	43193058	Spring			1	1
53	43019822	Holder, Sensor	8	8	8	8
54	4311L674	Wiring Diagram	1	1		
54	4311L675	Wiring Diagram			1	1
55	4318S454	Owner's Manual	1	1		

MMY-MP0801T8, MP1001T8

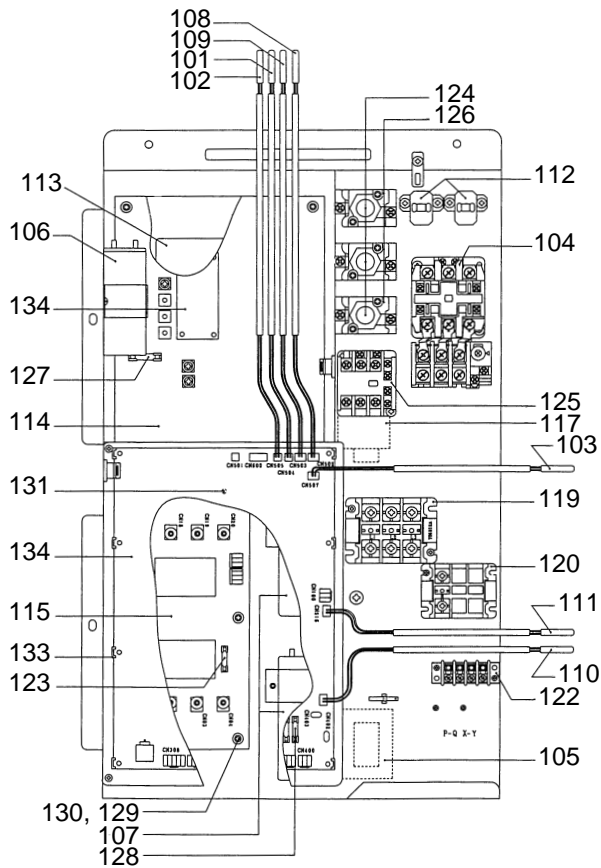

MMY-MP08018, MP10018

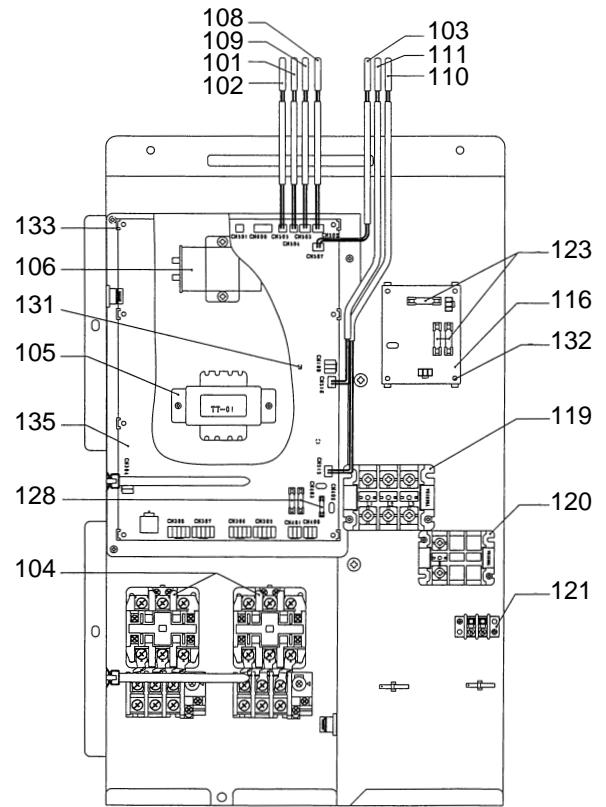

MMY-MP0801T8, MP1001T8

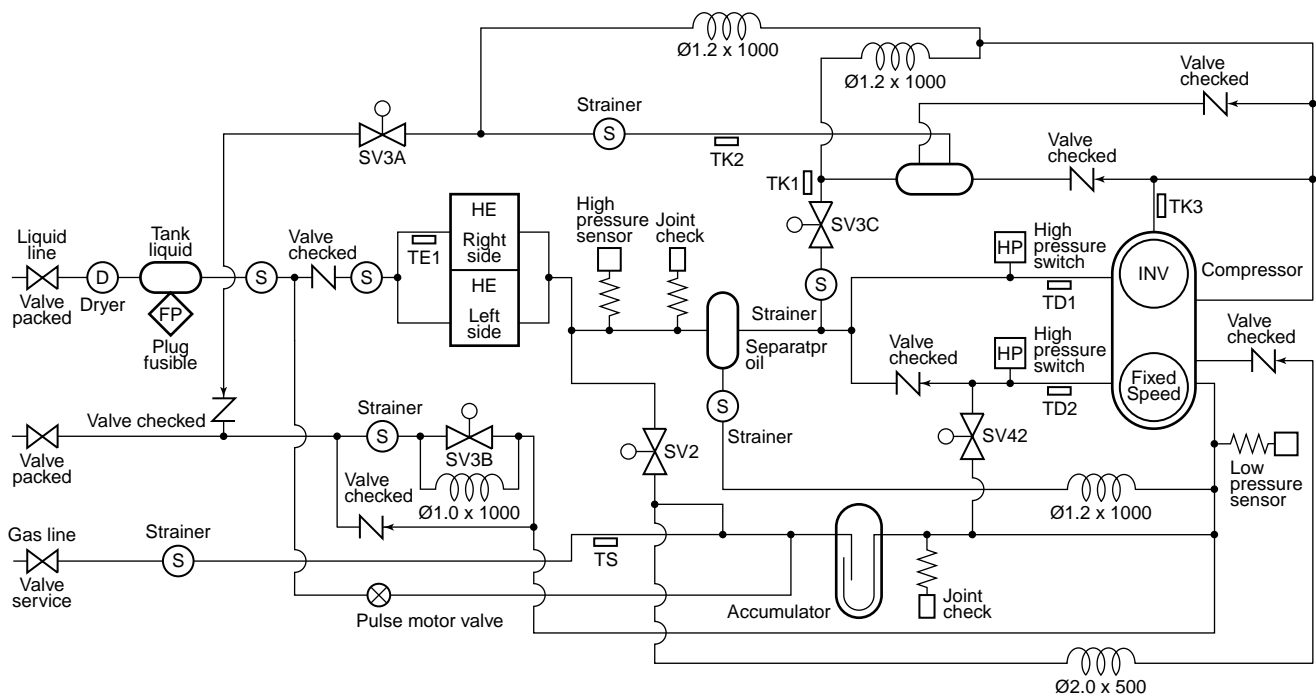

Location No.	Part No.	Description	Model name MMY-			
			MP0801T8	MP1001T8	MP08018	MP10018
101	43150230	Sensor	1	1	1	1
102	43150231	Sensor	1	1	1	1
103	43150239	Sensor	1	1	1	1
104	43152495	Contactora, Magnetic AC220-240V	2	2	1	1
105	43158167	Transformer, Power TT-01, AC240V	1	1	1	1
106	43155167	Capacitor, MF 8µF/450V AC	1	1	1	1
107	43155168	Capacitor, Electrolytic 2200µF/400V	2	2		
108	43150290	Sensor	1	1	1	1
109	43150291	Sensor	1	1	1	1
110	43150292	Sensor	1	1	1	1
111	43150293	Sensor	1	1	1	1
112	43153006	Starter, ELE	2	2		
113	43163044	Heatsink	1	1		
114	4316V107	P.C. Board Ass'y, IPDU MCC-1342	1	1		
115	4316V104	P.C. Board Ass'y, N/F MCC-1366	1	1		
116	4316V100	P.C. Board Ass'y, Surge MCC-1357			1	1
117	43055475	Reactor, CH-25Z	2	2		
118	43069889	Connector	1	1		
119	43160503	Terminal Block, 3p L1 L2 L3, 60A	1	1	1	1
120	43160449	Terminal, 3p AC600V 30A	1	1	1	1
121	43160445	Terminal Block, 2p 1A, AC30V			1	1
122	43160509	Terminal, 4p AC30V 1A	1	1		
123	43160520	Fuse, 6A AC500V	3	3	3	3
124	43160453	Fuse, 20A AC600V	3	3		
125	43152334	Contactora, Magnetic 50H8 230V	1	1		
126	43160451	Holder, Fuse AC600V 30A	3	3		
127	43160521	Fuse, 3.15A AC250V	1	1		
128	43160522	Fuse, 6.3A AC250V	3	3	3	3
129	43282001	Bushing, NB-300	10	10		
130	43183020	Collar, NA-310	10	10		
131	43163017	Supporter	4	4	4	4
132	43063240	Supporter, Ass'y			1	1
133	43063248	Supporter, Ass'y	2	2	2	2
134	4316V105	P.C. Board Ass'y, I/F-INV MCC-1343	1	1		
135	4316V106	P.C. Board Ass'y, I/F-FIX MCC-1343			1	1

MMY-MP08018, MP10018

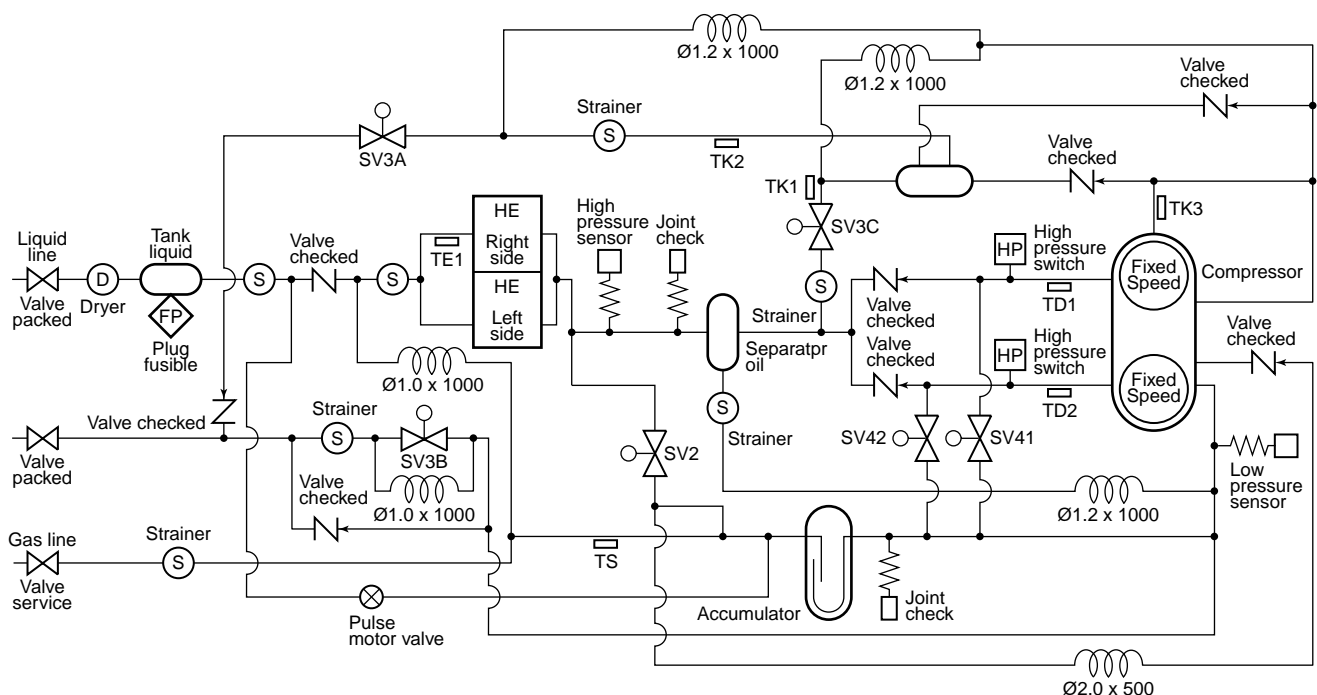

<Cooling Only model>

MMY-MP06018

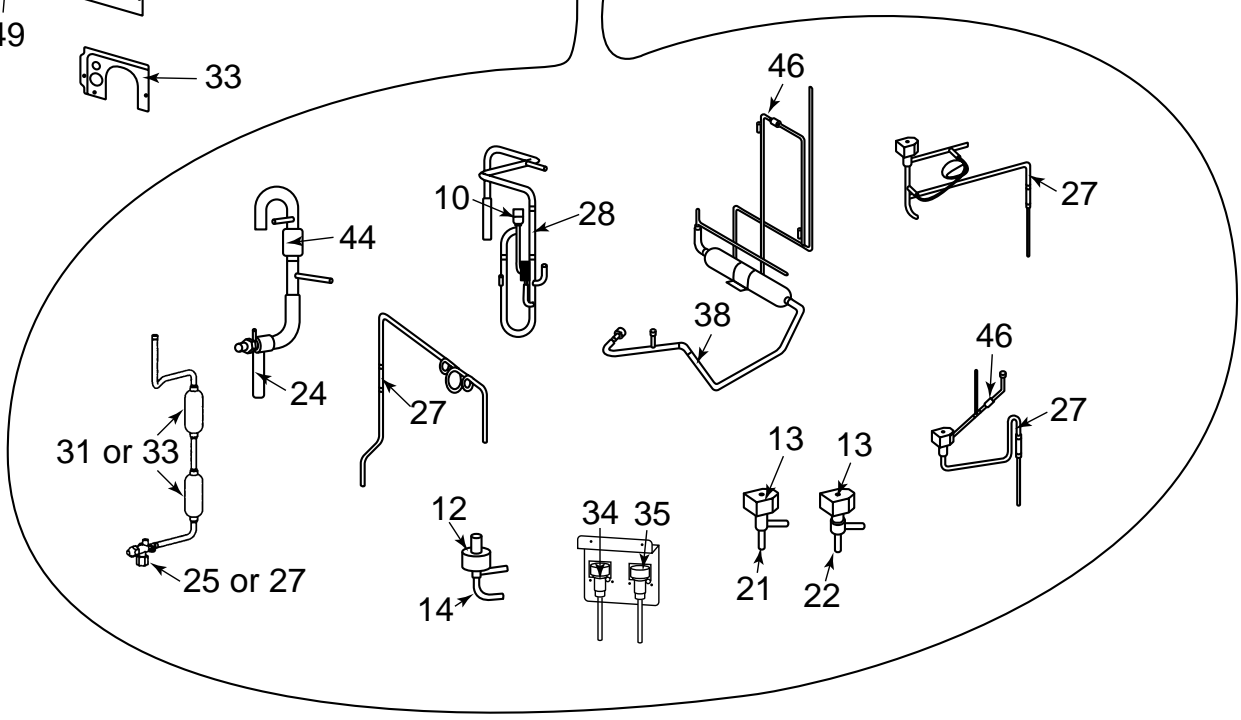
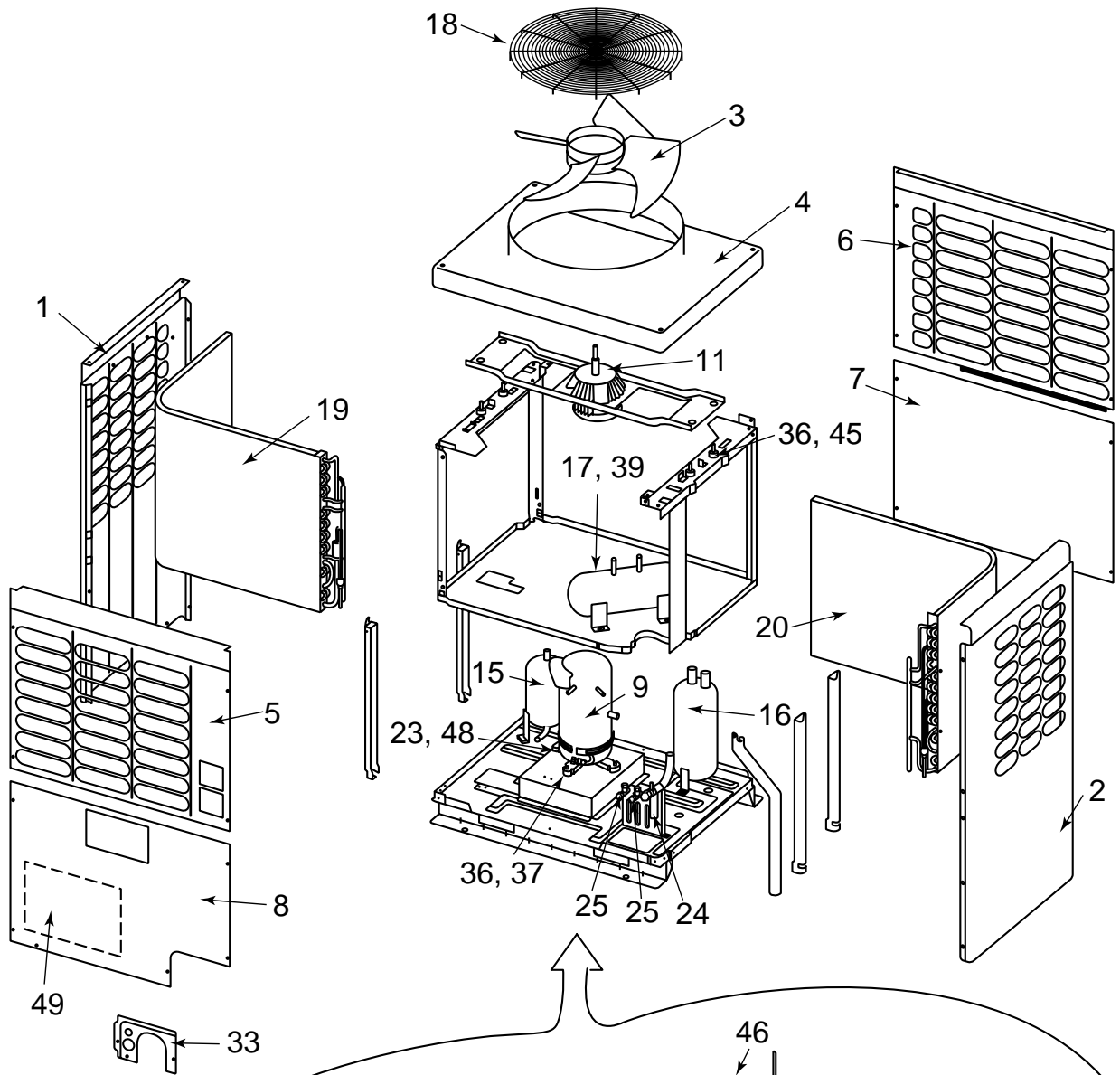

Location No.	Part No.	Description	Model name
			MMY-MP06018
1	43191594	Cabinet, Side Left	1
2	43191595	Cabinet, Side Right	1
3	43120203	Fan, Propeller DIA 630	1
4	43100209	Cabinet, UP	1
5	43191596	Cabinet, Front UP	1
6	43191597	Cabinet, Back UP	1
7	43191598	Cabinet, Back Down	1
8	43191599	Cabinet, Front Down	1
9	43141615	Compressor, YH620C-B	1
10	43151229	Switch, High Pressure, 20PS	1
11	43121679	Motor, Fan STF-200-350A	1
12	43146573	Coil, Pulse Motor Valve A12A15	1
13	43146548	Coil, Solenoid NEV-MOAJ510B0	5
14	43046377	Valve, Pulse Modulating, SEV18RC4	1
15	43148134	Separator, Oil	1
16	43148152	Accumulator	1
17	43148144	Tank, Liquid	1
18	43119444	Guard, Fan	1
19	4314G087	Condenser Ass'y	1
20	4314G088	Condenser Ass'y	1
21	43046151	Valve, 2-Way NEV202DXF	3
22	43046270	Valve, 2-Way NEV603DXF	1
23	43157097	Heater, Crank Case AC 240V 40W	1
24	43146351	Valve, Service	1
25	43046115	Valve, Packed 3/8 IN, 9.5DIA	2
26	43146383	Joint, Check	2
27	43046313	Valve, Checked BCV-302DXA30	3
28	43146495	Valve, Checked BCV-804DY	1
29	43047546	Nut, Flare 3/8 IN	1
30	43194077	Socket, 1/8 IN	2
31	43145079	Dryer	1
32	43148151	Strainer	1
33	43191600	Panel, CGCD2-Z08-C77	1
34	43149276	Sensor Ass'y, Low Pressure 150NH4-L	1
35	43149277	Sensor Ass'y, High Pressure 150NH4-H	1
36	43097204	Nut	8
37	43149253	Rubber, Cushion	4
38	43146283	Valve, Checked YCV5-3S-TF	2
39	43048009	Plug, Fusible	1
40	43147196	Bonnet, 1/4 IN 6.4	2
41	44246236	Tube, Capillary Bypass, 1.0x2.0x110L	1
42	44246239	Tube, Capillary ID 1.2	1
43	43047527	Tube, Capillary ID 2.0	1
44	43147529	Strainer	1
45	43049643	Cushion, Rubber	4
46	43047585	Strainer, Copper	3
47	43019822	Holder, Sensor	8
48	43193059	Spring	1
49	4311L676	Wiring Diagram	1

MMY-MP06018

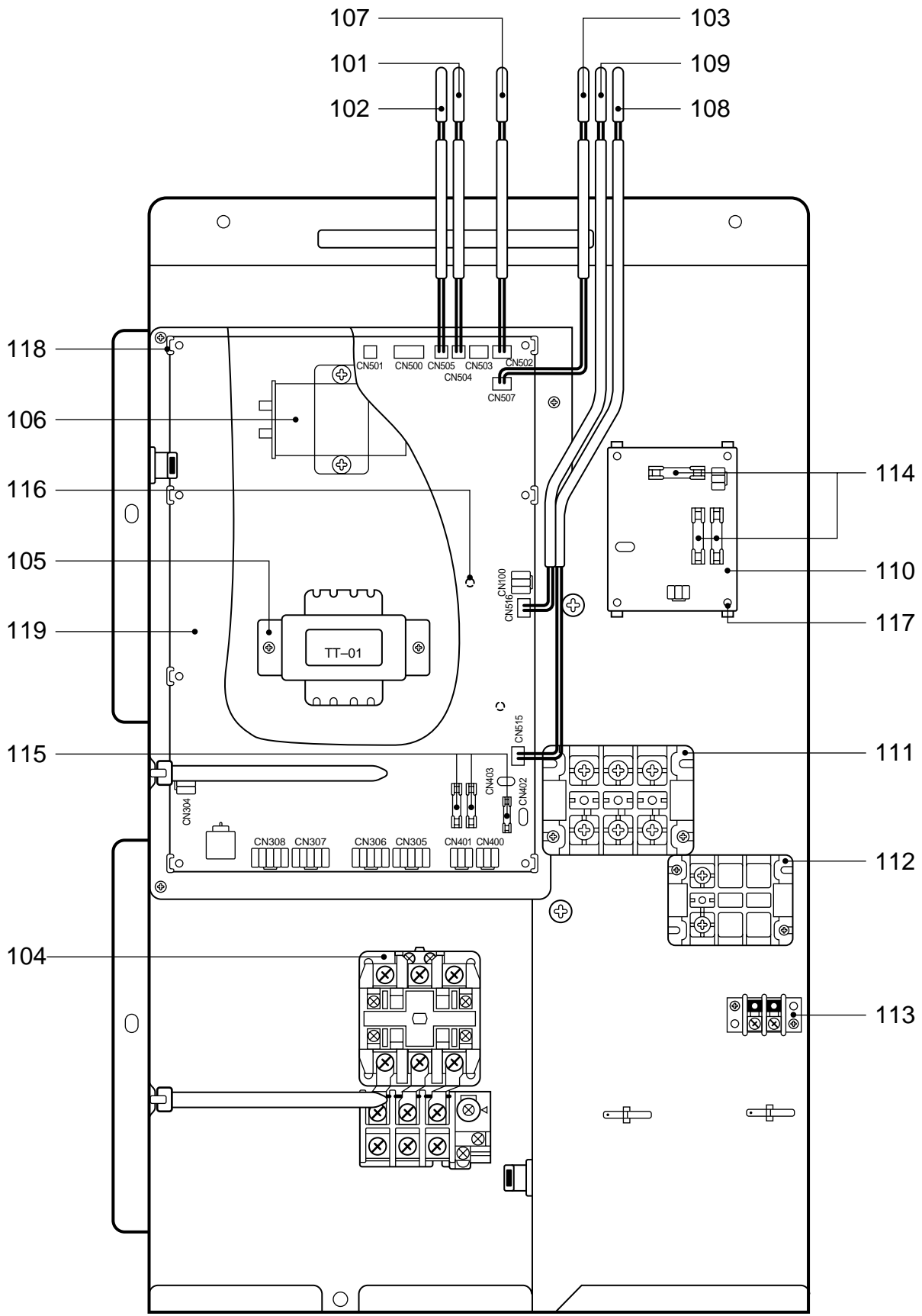

Location No.	Part No.	Description	Model name
			MMY-MP06018
101	43150230	Sensor	1
102	43150231	Sensor	1
103	43150239	Sensor	1
104	43152412	Contactora, Magnetic AC220-240V	1
105	43158167	Transformer, Power TT-01, AC240V	1
106	43155167	Capacitor, MF 8µF/450V AC	1
107	43150290	Sensor	1
108	43150292	Sensor	1
109	43150293	Sensor	1
110	4316V100	P.C. Board Ass'y, Surge MCC-1357	1
111	43160503	Terminal Block, 3p, L1 L2 L3, 60A	1
112	43160449	Terminal, 3p AC600V 30A	1
113	43160445	Terminal Block, 2p 1A, AC30V	1
114	43160520	Fuse, 6A AC500V	3
115	43160522	Fuse, 6.3A AC250V	3
116	43163017	Supporter	4
117	43063240	Supporter, Ass'y	1
118	43063248	Supporter, Ass'y	2
119	4316V106	P.C. Board Ass'y, I/F-FIX, MCC-1343	1

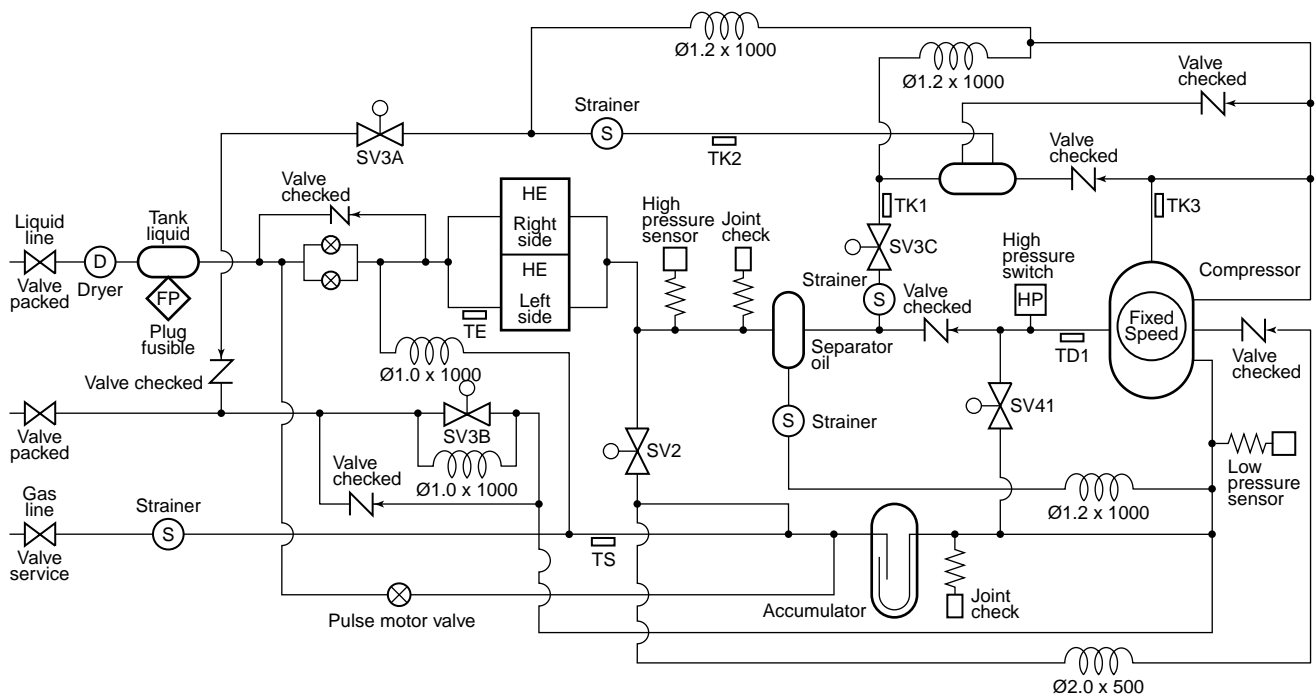

<Cooling Only model>

MMY-MP0801T8, MP1001T8

MMY-MP08018, MP10018

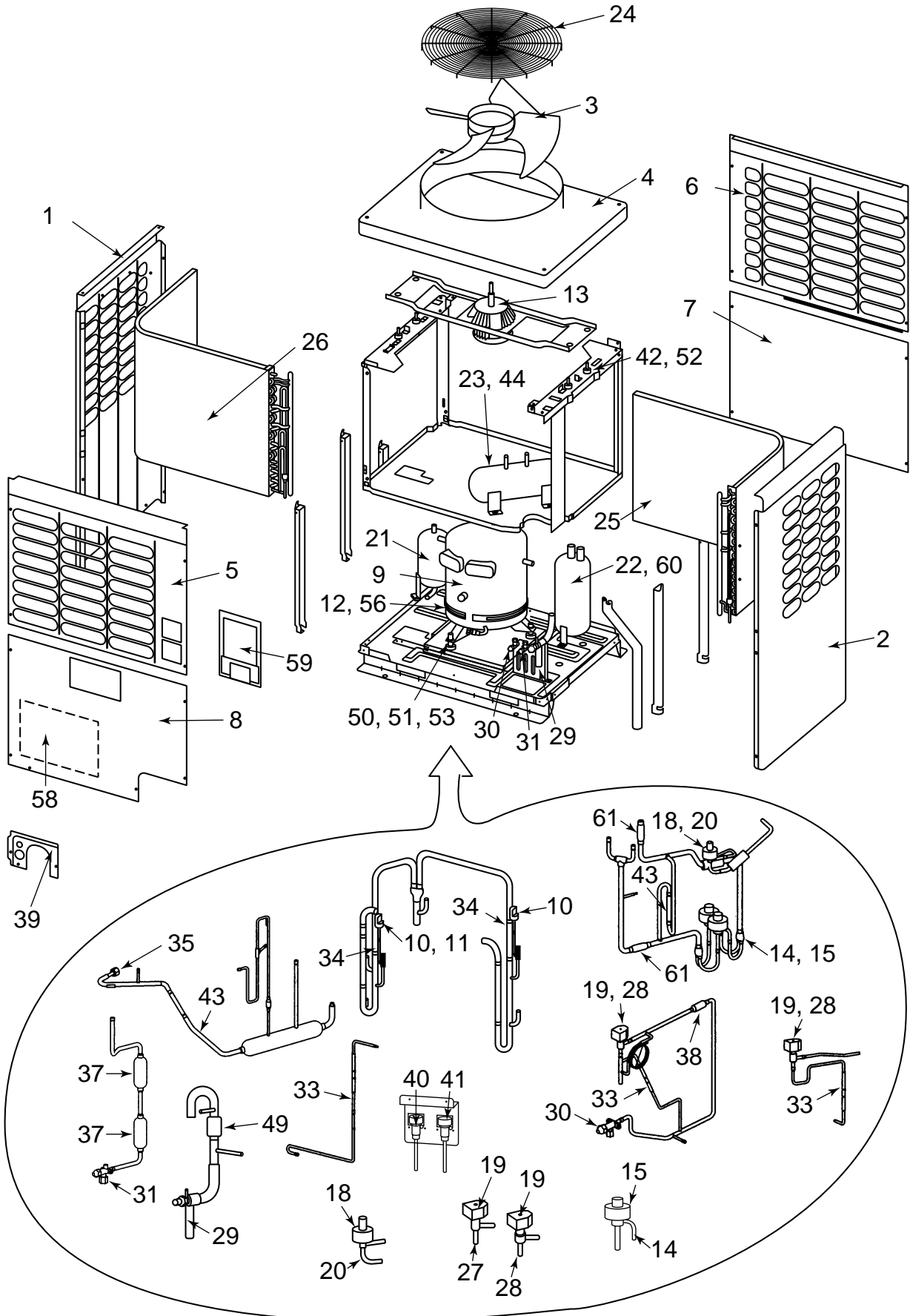

Location No.	Part No.	Description	Model name		MMY-	
			MP0801T8	MP1001T8	MP08018	MP10018
1	43191594	Cabinet, Side Left	1	1	1	1
2	43191595	Cabinet, Side Right	1	1	1	1
3	43120203	Fan, Propeller DIA 630	1	1	1	1
4	43100209	Cabinet, UP	1	1	1	1
5	43191596	Cabinet, Front UP	1	1	1	1
6	43191597	Cabinet, Back UP	1	1	1	1
7	43191598	Cabinet, Back Down	1	1	1	1
8	43191599	Cabinet, Front Down	1	1	1	1
9	43141617	Compressor, MG1450CW-21B	1	1		
9	43141714	Compressor, YG1800CW-B1				1
9	43141715	Compressor, YG1700CW-B1			1	
10	43151264	Switch, High Pressure ACB-JA64	1	1	2	2
11	43151263	Switch, High Pressure ACB-JB128	1	1		
12	43157270	Heater, Crank Case			1	1
13	43121679	Motor, Fan STF-200-350A	1	1	1	1
14	43146520	Valve, Pulse Modulation	2	2	2	2
15	43146521	Coil, Pulse Motor Valve	2	2	2	2
18	43146573	Coil, Pulse Motor Valve A12A15	1	1	1	1
19	43146612	Coil, Solenoid VPV-MOAJ524D0	5	5	6	6
20	43046377	Valve, Pulse Modulating, SEV18RC4	1	1	1	1
21	43148134	Separator, Oil	1	1	1	1
22	43148152	Accumulator	1	1	1	1
23	43148141	Tank, Liquid	1	1		
23	43148144	Tank, Liquid			1	1
24	43119444	Guard, Fan	1	1	1	1
25	4314G107	Condenser Ass'y	1	1	1	1
26	4314G108	Condenser Ass'y	1	1	1	1
27	43046151	Valve, 2-Way NEV202DXF	3	3	4	4
28	43046270	Valve, 2-Way NEV603DXF	2	2	2	2
29	43146518	Valve, Service	1	1	1	1
30	43046115	Valve, Packed 3/8 IN, 9.5DIA	1	1	1	1
31	43146378	Valve, Packed 1/2 IN	1	1	1	1
32	43146582	Joint, Check	2	2	2	2
33	43146581	Valve, Checked BCV-302DY	3	3	3	3
34	43146495	Valve, Checked BCV-804DY	1	1	2	2
35	43047546	Nut, Flare 3/8 IN	1	1	1	1
36	43194077	Socket, 1/8 IN	2	2	2	2
37	43145107	Dryer	2	2	2	2
38	43148151	Strainer	1	1	1	1
39	43191600	Panel, CGCD2-Z08-C77	1	1	1	1
40	43149276	Sensor Ass'y, Low Pressure 150NH4-L	1	1	1	1
41	43149277	Sensor Ass'y, High Pressure 150NH4-H	1	1	1	1
42	43097204	Nut	4	4	4	4
43	43146580	Valve, Checked YCV5-3SPTF-1	3	3	3	3
44	43148171	Plug, Fusible	1	1	1	1
45	43147196	Bonnet, 1/4 IN 6.4	2	2	2	2
46	44246236	Tube, Capillary Bypass, 1.0x2.0x110L	1	1	1	1
47	44246239	Tube, Capillary ID 1.2	1	1	1	1
48	43047527	Tube, Capillary ID 2.0x2000L	1	1	1	1
49	43147529	Strainer	1	1	1	1
50	43195185	Cushion, Under Compressor	3	3	3	3
51	43195186	Cushion, Under Compressor	3	3	3	3
52	43049643	Cushion, Rubber	4	4	4	4
53	43107200	Base, Spring	3	3	3	3
55	43047585	Strainer, Copper	3	3	3	3
56	43193058	Spring			1	1
57	43019822	Holder, Sensor	8	8	8	8
58	4311N639	Wiring Diagram	1	1		
58	4311N640	Wiring Diagram			1	1
59	4318S146	Owner's Manual	1	1		
60	43157276	Heater, Case	1	1	1	1
61	43147640	Strainer	2	2	2	2

MMY-MP0801T8, MP1001T8

MMY-MP08018, MP10018

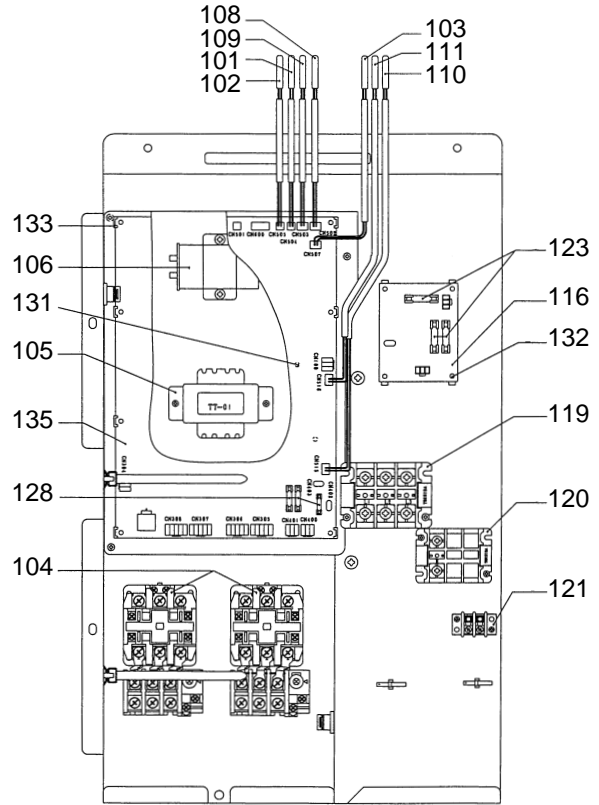
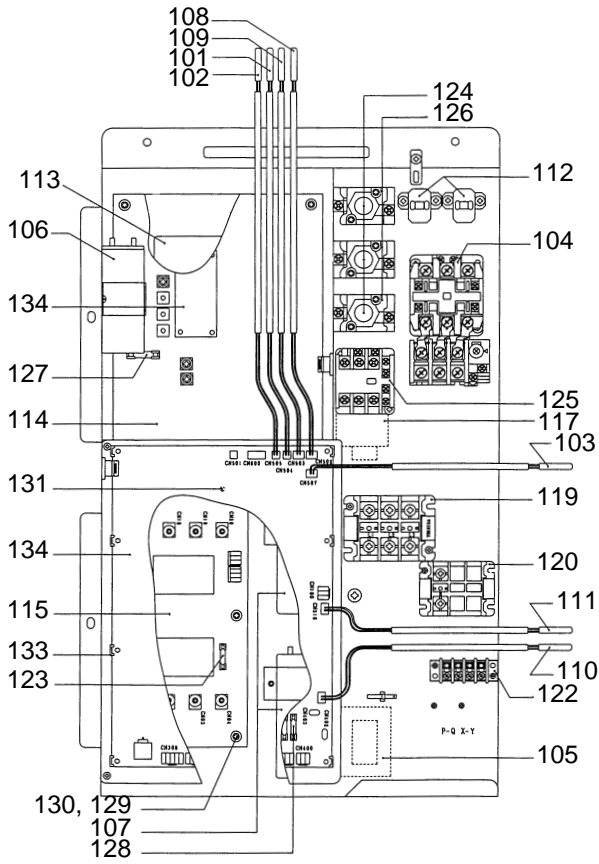

MMY-MP0801T8, MP1001T8

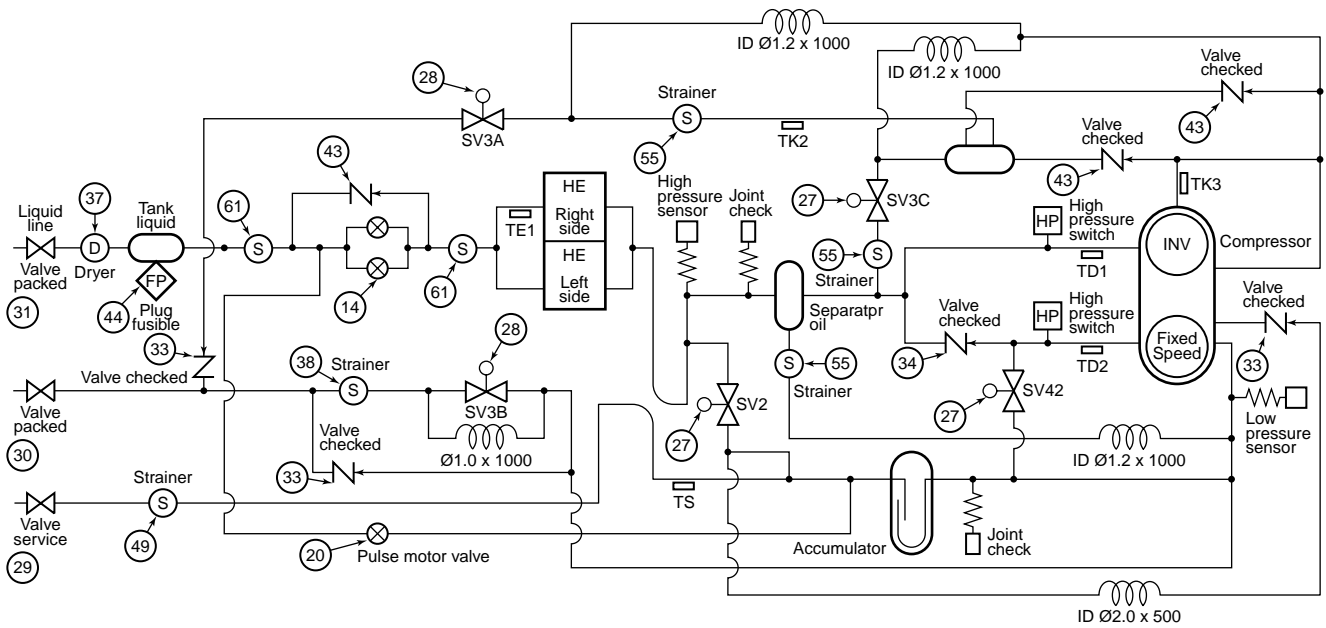

Location No.	Part No.	Description	Model name MMY-			
			MP0801T8	MP1001T8	MP08018	MP10018
101	43150230	Sensor	1	1	1	1
102	43150231	Sensor	1	1	1	1
103	43150239	Sensor	1	1	1	1
104	43152495	Connector, Magnetic AC220-240V	1	1	2	2
105	43158167	Transformer, Power TT-01, AC240V	1	1	1	1
106	43155167	Capacitor, MF 8 μ F/450V AC	1	1	1	1
107	43155168	Capacitor, Electrolytic 2200 μ F/400V	2	2		
108	43150290	Sensor	1	1	1	1
109	43150291	Sensor	1	1	1	1
110	43150292	Sensor	1	1	1	1
111	43150293	Sensor	1	1	1	1
112	43153006	PTC-Thermistor	2	2		
113	43163044	Heatsink	1	1		
114	4316V107	P.C. Board Ass'y, IPDU MCC-1342	1	1		
115	4316V104	P.C. Board Ass'y, N/F MCC-1366	1	1		
116	4316V100	P.C. Board Ass'y, Surge MCC-1357			1	1
117	43055475	Reactor, CH-25-Z	2	2		
118	43069889	Connector	1	1		
119	43160503	Terminal Block, 3p L1 L2 L3, 60A	1	1	1	1
120	43160449	Terminal, 3p AC600V 30A	1	1	1	1
121	43160445	Terminal Block, 2p 1A, AC30V			1	1
122	43160509	Terminal, 4p AC30V 1A	1	1		
123	43160520	Fuse, 6A AC500V	3	3	3	3
124	43160453	Fuse, 20A AC600V	3	3		
125	43152334	Connector, Magnetic 50H8 230V	1	1		
126	43160451	Holder, Fuse AC600V 30A	3	3		
127	43160521	Fuse, 3.15A AC250V	1	1		
128	43160522	Fuse, 6.3A AC250V	3	3	3	3
129	43282001	Bushing, NB-300	10	10		
130	43183020	Collar, NA-310	10	10		
131	43163017	Supporter	4	4	4	4
132	43063240	Supporter, Ass'y			1	1
133	43063248	Supporter, Ass'y	2	2	2	2
134	4316V105	P.C. Board Ass'y, I/F-INV MCC-1343	1	1		
135	4316V106	P.C. Board Ass'y, I/F-FIX MCC-1343			1	1

MMY-MP08018, MP10018

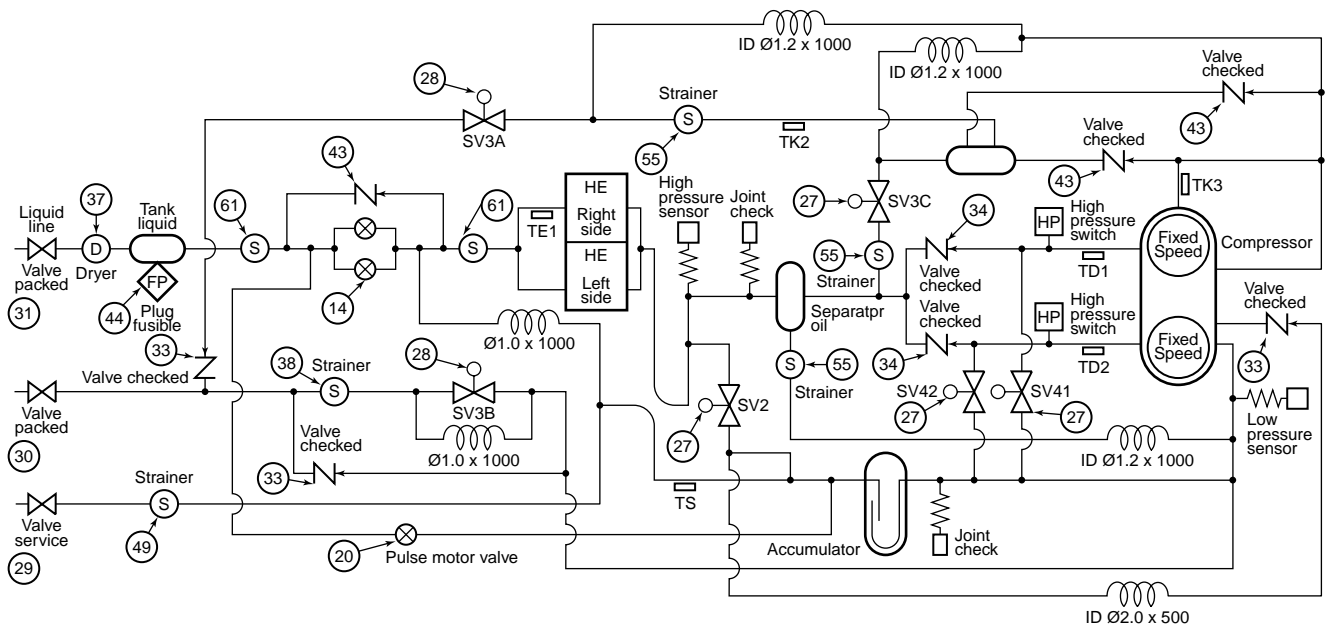

<Cooling Only model>
MMY-MP06018

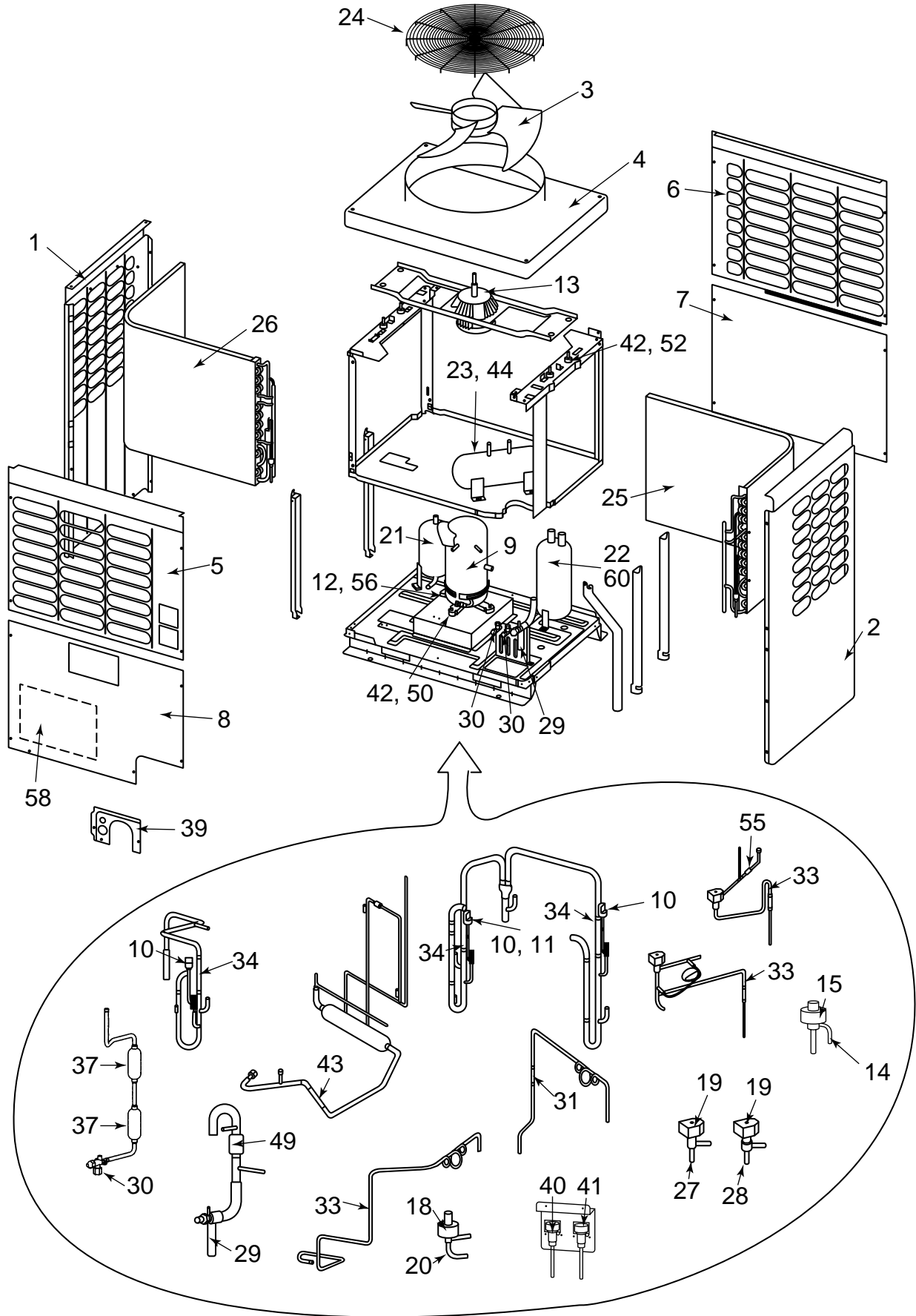

Location No.	Part No.	Description	Model name
			MMY-MP06018
1	43191594	Cabinet, Side Left	1
2	43191595	Cabinet, Side Right	1
3	43120203	Fan, Propeller DIA 630	1
4	43100209	Cabinet, UP	1
5	43191596	Cabinet, Front UP	1
6	43191597	Cabinet, Back UP	1
7	43191598	Cabinet, Back Down	1
8	43191599	Cabinet, Front Down	1
9	43141401	Compressor, YG890C-B1	1
10	43151264	Switch, High Pressure	1
12	43157271	Heater, Crank Case AC 240V 40W	1
13	43121679	Motor, Fan STF-200-350A	1
14	43146520	Valve, Pulse Modulation	1
15	43146521	Coil, Pulse Motor Valve	1
18	43146573	Coil, Pulse Motor Valve A12A15	1
19	43146612	Coil, Solenoid VPV-MOAJ514D0	5
20	43046377	Valve, Pulse Modulating, SEV18RC4	1
21	43148134	Separator, Oil	1
22	43148152	Accumulator	1
23	43148144	Tank, Liquid	1
24	43119444	Guard, Fan	1
25	4314G110	Condenser Ass'y	1
26	4314G109	Condenser Ass'y	1
27	43046151	Valve, 2-Way NEV202DXF	3
28	43046270	Valve, 2-Way NEV603DXF	2
29	43146518	Valve, Service	1
30	43046115	Valve, Packed 3/8 IN, 9.5DIA	2
32	43146582	Joint, Check	2
33	43146581	Valve, Checked BCV-302DY	3
34	43146495	Valve, Checked BCV-804DY	1
35	43047546	Nut, Flare 3/8 IN	1
36	43194077	Socket, 1/8 IN	2
37	43145107	Dryer	2
38	43148151	Strainer	1
39	43191600	Panel, CGCD2-Z08-C77	1
40	43149276	Sensor Ass'y, Low Pressure 150NH4-L	1
41	43149277	Sensor Ass'y, High Pressure 150NH4-H	1
42	43097204	Nut	8
43	43146580	Valve, Checked YCV5-3SPTF-1	3
44	43048171	Plug, Fusible	1
45	43147196	Bonnet, 1/4 IN 6.4	2
46	44246236	Tube, Capillary Bypass, 1.0x2.0x110L	1
47	44246239	Tube, Capillary ID 1.2	1
48	43047491	Tube, Capillary ID 1.5	1
49	43147529	Strainer	1
50	43149253	Rubber, Cushion	4
52	43049643	Cushion, Rubber	4
55	43047585	Strainer, Copper	3
56	43193059	Spring	1
57	43019822	Holder, Sensor	8
58	4311N037	Wiring Diagram	1
60	43157276	Heater, Case	1
61	43147640	Strainer	2

MMY-MP06018

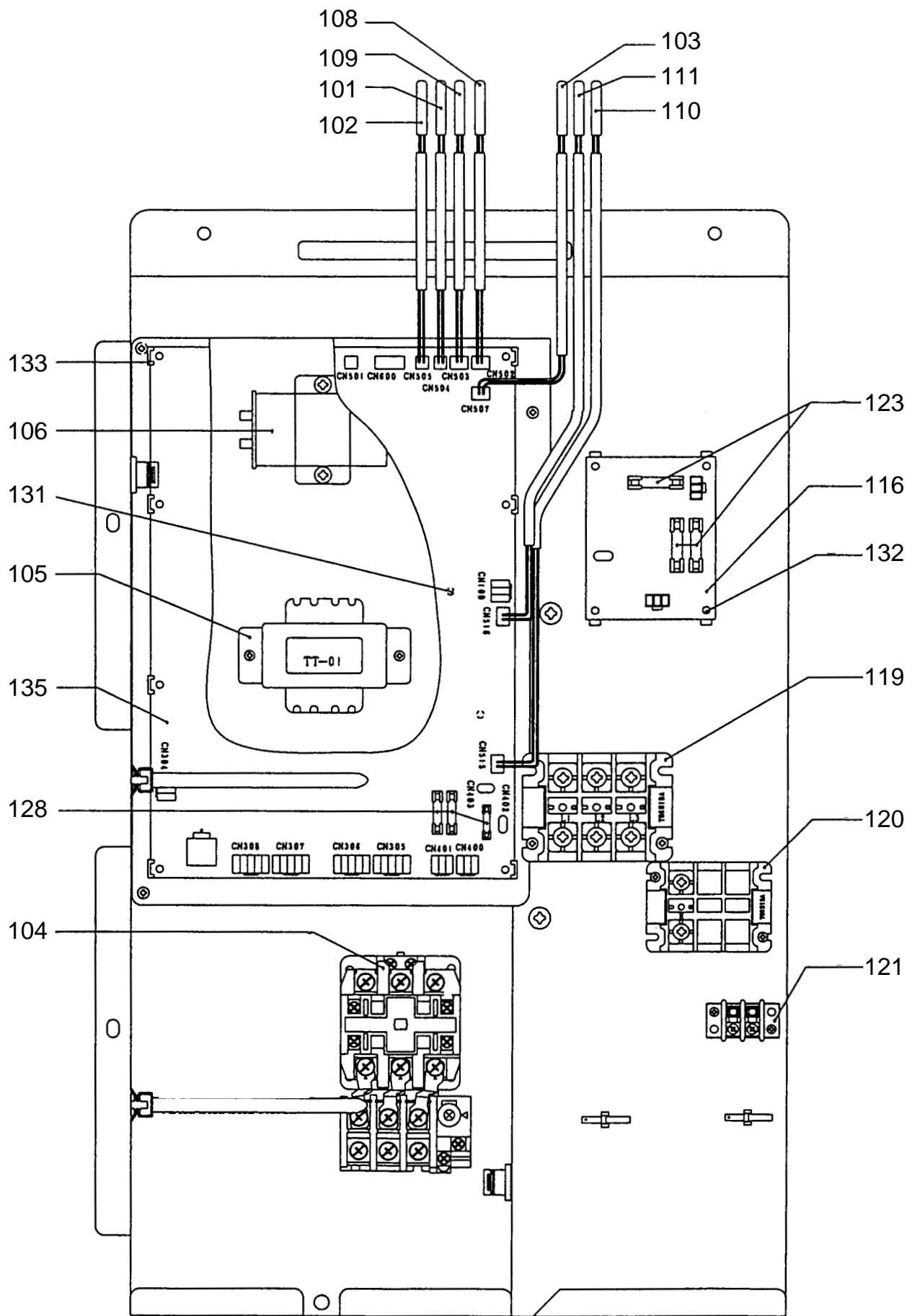

Location No.	Part No.	Description	Model name
			MMY-MP06018
101	43150230	Sensor	1
102	43150231	Sensor	1
103	43150239	Sensor	1
104	43152495	Connector, Magnetic AC220-240V	1
105	43158167	Transformer, Power TT-01, AC240V	1
106	43155167	Capacitor, MF 8 μ F/450V AC	1
108	43150290	Sensor	1
110	43150292	Sensor	1
111	43150293	Sensor	1
116	4316V100	PC Board Ass'y, Surge MCC-1357	1
119	43160503	Terminal Block, 3p, L1 L2 L3, 60A	1
120	43160449	Terminal, 3p AC600V 30A	1
121	43160445	Terminal Block, 2p 1A, AC30V	1
123	43160520	Fuse, 6A AC500V	3
128	43160522	Fuse, 6.3A AC250V	3
131	43163017	Supporter	4
132	43063240	Supporter, Ass'y	1
133	43063248	Supporter, Ass'y	2
135	4316V106	P.C. Board Ass'y, I/F-FIX, M	1

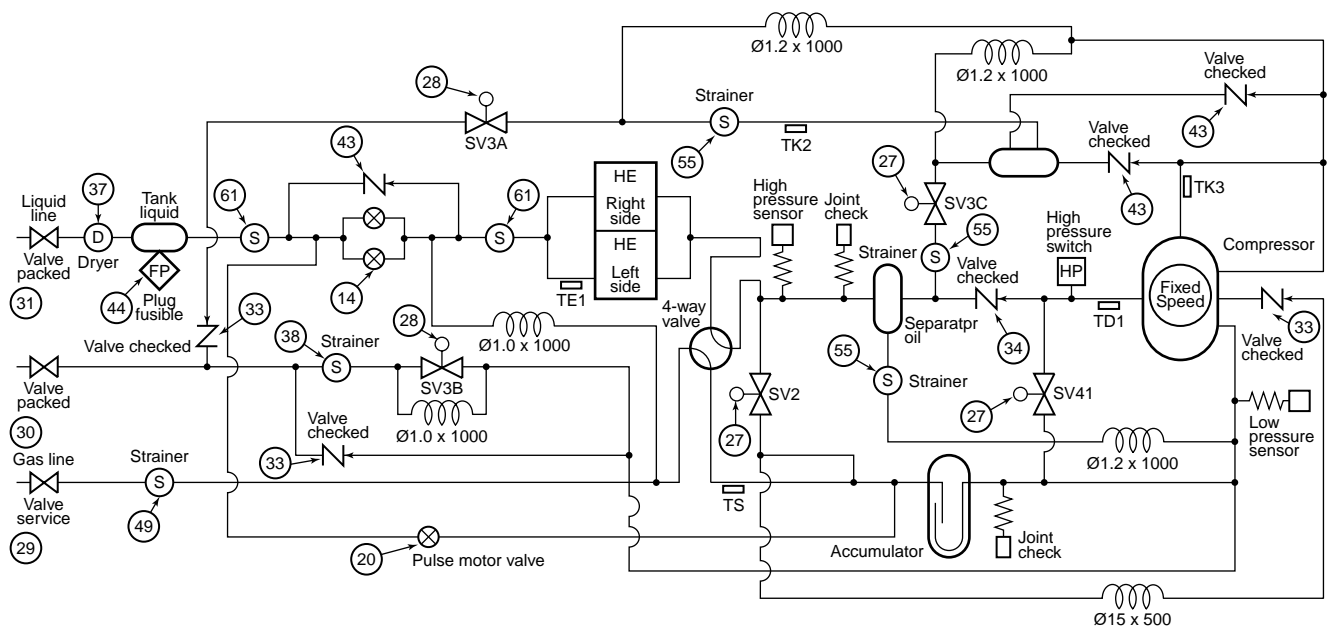

Location No.	Part No.	Description	Model name		MMY-	
			MP0801HT8	MP1001HT8	MP0801H8	MP1001H8
1	43191594	Cabinet, Side Left	1	1	1	1
2	43191595	Cabinet, Side Right	1	1	1	1
3	43120203	Fan, Propeller DIA 630	1	1	1	1
4	43100209	Cabinet, UP	1	1	1	1
5	43191596	Cabinet, Front UP	1	1	1	1
6	43191597	Cabinet, Back UP	1	1	1	1
7	43191598	Cabinet, Back Down	1	1	1	1
8	43191599	Cabinet, Front Down	1	1	1	1
9	43141617	Compressor, MG1450CW-21B	1	1		
9	43141714	Compressor, YG1800CW-B1				1
9	43141715	Compressor, YG1700CW-B1			1	
10	43151264	Switch, High Pressure ACB-JA64	1	1	2	2
11	43151263	Switch, High Pressure ACB-JB128	1	1		
12	43157270	Heater, Crank Case			1	1
13	43121679	Motor, Fan STF-200-350A	1	1	1	1
14	43146520	Valve, Pulse Modulation	2	2	2	2
15	43146521	Coil, Pulse Motor Valve	2	2	2	2
17	43146611	Coil, Solenoid, VHV-01AJ502E1	1	1	1	1
18	43146573	Coil, Pulse Motor Valve A12A15	1	1	1	1
19	43146612	Coil, Solenoid VPV-MOAJ524D0	5	5	6	6
20	43046377	Valve, Pulse Modulating, SEV18RC4	1	1	1	1
21	43148134	Separator, Oil	1	1	1	1
22	43148152	Accumulator	1	1	1	1
23	43148141	Tank, Liquid	1	1		
23	43148144	Tank, Liquid			1	1
24	43119444	Guard, Fan	1	1	1	1
25	4314G107	Condenser Ass'y	1	1	1	1
26	4314G108	Condenser Ass'y	1	1	1	1
27	43046151	Valve, 2-Way NEV202DXF	3	3	4	4
28	43046270	Valve, 2-Way NEV603DXF	2	2	2	2
29	43146518	Valve, Service	1	1	1	1
30	43046115	Valve, Packed 3/8 IN, 9.5DIA	1	1	1	1
31	43146378	Valve, Packed 1/2 IN	1	1	1	1
32	43146582	Joint, Check	2	2	2	2
33	43146581	Valve, Checked BCV-302DY	3	3	3	3
34	43146495	Valve, Checked BCV-804DY	1	1	2	2
35	43047546	Nut, Flare 3/8 IN	1	1	1	1
36	43194077	Socket, 1/8 IN	2	2	2	2
37	43145107	Dryer	2	2	2	2
38	43148151	Strainer	1	1	1	1
39	43191600	Panel, CGCD2-Z08-C77	1	1	1	1
40	43149276	Sensor Ass'y, Low Pressure 150NH4-L	1	1	1	1
41	43149277	Sensor Ass'y, High Pressure 150NH4-H	1	1	1	1
42	43097204	Nut	4	4	4	4
43	43146580	Valve, Checked YCV5-3SPTF-1	3	3	3	3
44	43148171	Plug, Fusible	1	1	1	1
45	43147196	Bonnet, 1/4 IN 6.4	2	2	2	2
46	44246236	Tube, Capillary Bypass, 1.0x2.0x110L	1	1	1	1
47	44246239	Tube, Capillary ID 1.2	1	1	1	1
48	43047527	Tube, Capillary ID 2.0x2000L	1	1	1	1
49	43147529	Strainer	1	1	1	1
50	43195185	Cushion, Under Compressor	3	3	3	3
51	43195186	Cushion, Under Compressor	3	3	3	3
52	43049643	Cushion, Rubber	4	4	4	4
53	43107200	Base, Spring	3	3	3	3
55	43047585	Strainer, Copper	3	3	3	3
56	43193058	Spring			1	1
57	43019822	Holder, Sensor	8	8	8	8
58	4311N639	Wiring Diagram	1	1		
58	4311N640	Wiring Diagram			1	1
59	4318T146	Owner's Manual	1	1		
60	43157276	Heater, Case	1	1	1	1
61	43147640	Strainer	2	2	2	2

Location No.	Part No.	Description	Model name MMY-			
			MP0801HT8	MP1001HT8	MP0801H8	MP1001H8
101	43150230	Sensor	1	1	1	1
102	43150231	Sensor	1	1	1	1
103	43150239	Sensor	1	1	1	1
104	43152495	Connector, Magnetic AC220-240V	1	1	2	2
105	43158167	Transformer, Power TT-01, AC240V	1	1	1	1
106	43155167	Capacitor, MF 8 μ F/450V AC	1	1	1	1
107	43155168	Capacitor, Electrolytic 2200 μ F/400V	2	2		
108	43150290	Sensor	1	1	1	1
109	43150291	Sensor	1	1	1	1
110	43150292	Sensor	1	1	1	1
111	43150293	Sensor	1	1	1	1
112	43153006	PTC-Thermistor	2	2		
113	43163044	Heatsink	1	1		
114	4316V107	P.C. Board Ass'y, IPDU MCC-1342	1	1		
115	4316V104	P.C. Board Ass'y, N/F MCC-1366	1	1		
116	4316V100	P.C. Board Ass'y, Surge MCC-1357			1	1
117	43055475	Reactor, CH-25-Z	2	2		
118	43069889	Connector	1	1		
119	43160503	Terminal Block, 3p L1 L2 L3, 60A	1	1	1	1
120	43160449	Terminal, 3p AC600V 30A	1	1	1	1
121	43160445	Terminal Block, 2p 1A, AC30V			1	1
122	43160509	Terminal, 4p AC30V 1A	1	1		
123	43160520	Fuse, 6A AC500V	3	3	3	3
124	43160453	Fuse, 20A AC600V	3	3		
125	43152334	Connector, Magnetic 50H8 230V	1	1		
126	43160451	Holder, Fuse AC600V 30A	3	3		
127	43160521	Fuse, 3.15A AC250V	1	1		
128	43160522	Fuse, 6.3A AC250V	3	3	3	3
129	43282001	Bushing, NB-300	10	10		
130	43183020	Collar, NA-310	10	10		
131	43163017	Supporter	4	4	4	4
132	43063240	Supporter, Ass'y			1	1
133	43063248	Supporter, Ass'y	2	2	2	2
134	4316V105	P.C. Board Ass'y, I/F-INV MCC-1343	1	1		
135	4316V106	P.C. Board Ass'y, I/F-FIX MCC-1343			1	1
136	43169620	Ferrite, Core	2	2		

MMY-MP0801H8, MP1001H8

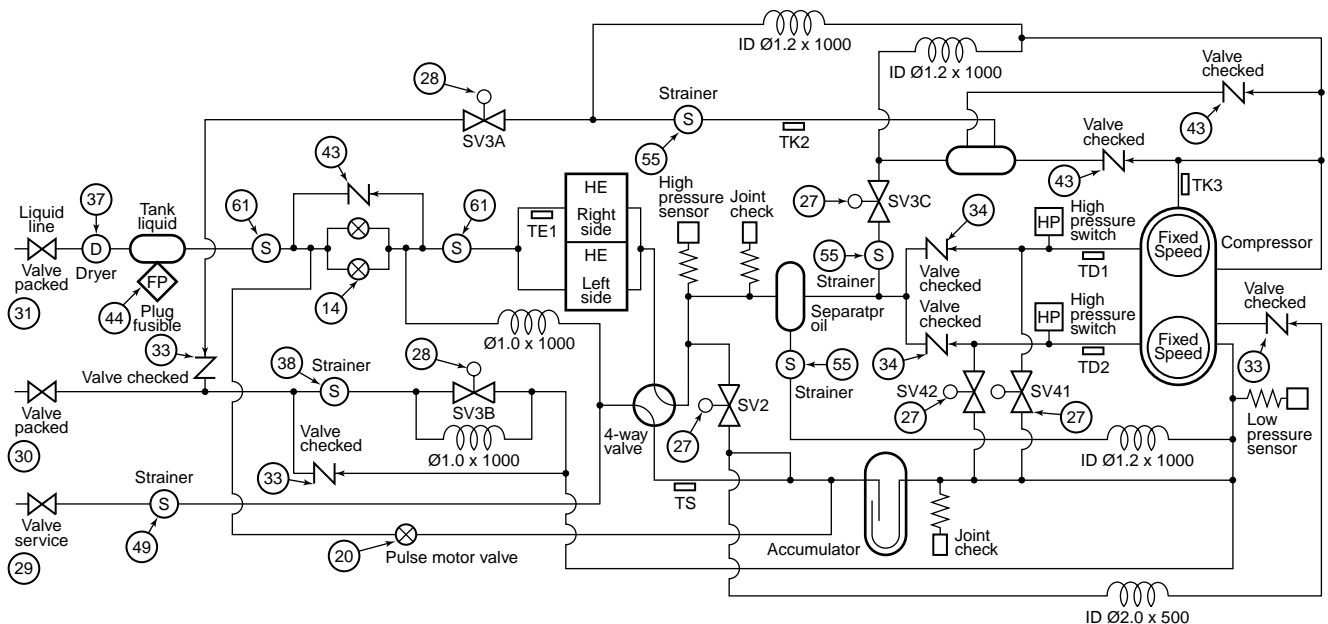

<Heat Pump model>

MMY-MP0601H8

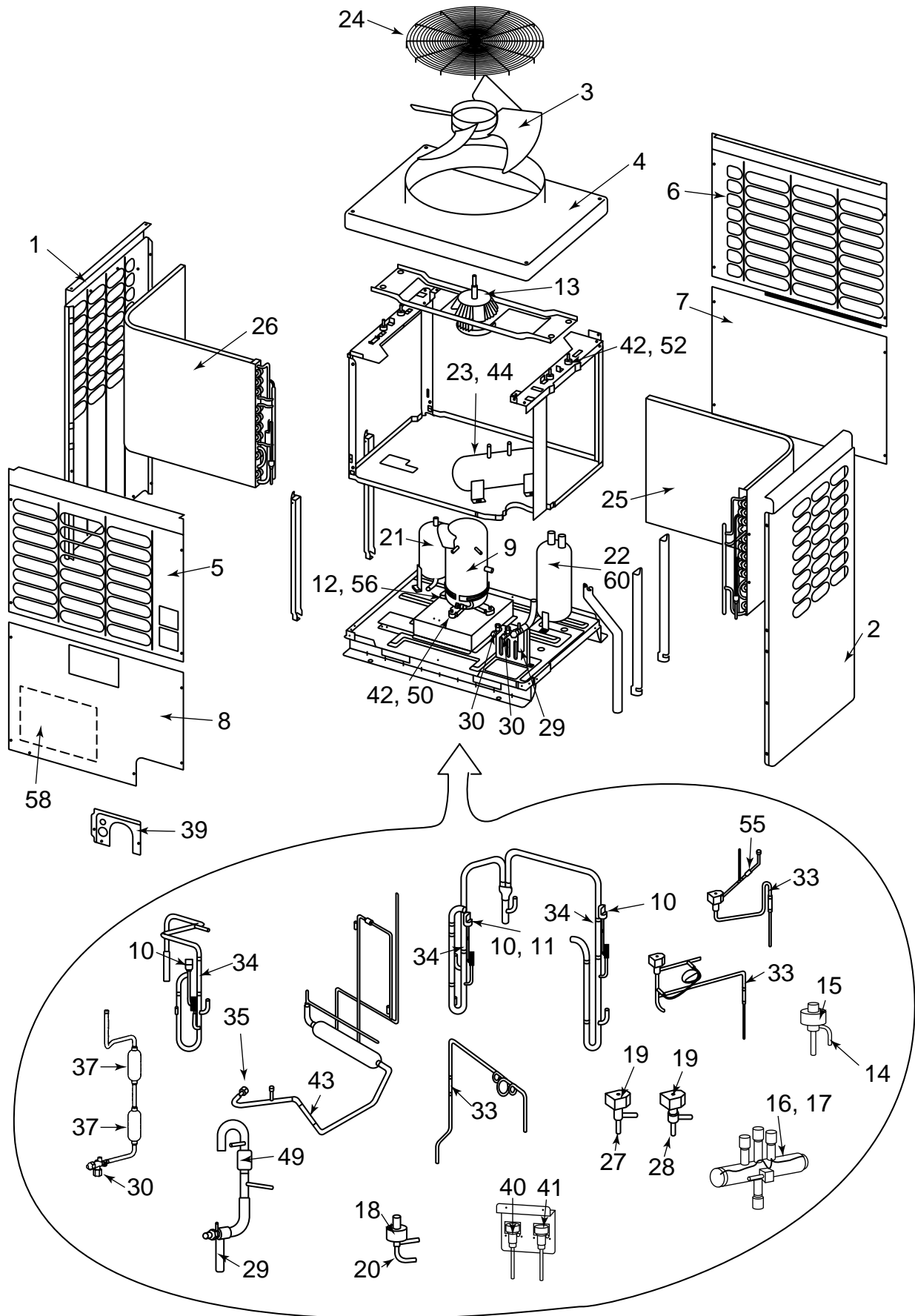

Location No.	Part No.	Description	Model name
			MMY-MP0601H8
1	43191594	Cabinet, Side Left	1
2	43191595	Cabinet, Side Right	1
3	43120203	Fan, Propeller DIA 630	1
4	43100209	Cabinet, UP	1
5	43191596	Cabinet, Front UP	1
6	43191597	Cabinet, Back UP	1
7	43191598	Cabinet, Back Down	1
8	43191599	Cabinet, Front Down	1
9	43141401	Compressor, YG890C-B1	1
10	43151264	Switch, High Pressure, ACB-JA64	1
12	43157271	Heater, Crank Case AC 240V 40W	1
13	43121679	Motor, Fan STF-200-350A	1
14	43146520	Valve, Pulse Modulation	1
15	43146521	Coil, Pulse Motor Valve	1
16	43146499	Valve 4-way, CHV-0401	
17	43146611	Coil, Solenoid, VHV-01AJ502E1	
18	43146573	Coil, Pulse Motor Valve A12A15	1
19	43146612	Coil, Solenoid VPV-MOAJ524D0	5
20	43046377	Valve, Pulse Modulating, SEV18RC4	1
21	43148134	Separator, Oil	1
22	43148152	Accumulator	1
23	43148144	Tank, Liquid	1
24	43119444	Guard, Fan	1
25	4314G110	Condenser Ass'y	1
26	4314G109	Condenser Ass'y	1
27	43046151	Valve, 2-Way NEV202DXF	3
28	43046270	Valve, 2-Way NEV603DXF	2
29	43146518	Valve, Service	1
30	43046115	Valve, Packed 3/8 IN, 9.5DIA	2
32	43146582	Joint, Check	2
33	43146581	Valve, Checked BCV-302DY	3
34	43146495	Valve, Checked BCV-804DY	1
35	43047546	Nut, Flare 3/8 IN	1
36	43194077	Socket, 1/8 IN	2
37	43145107	Dryer	2
38	43148151	Strainer	1
39	43191600	Panel, CGCD2-Z08-C77	1
40	43149276	Sensor Ass'y, Low Pressure 150NH4-L	1
41	43149277	Sensor Ass'y, High Pressure 150NH4-H	1
42	43097204	Nut	8
43	43146580	Valve, Checked YCV5-3SPTF-1	3
44	43148171	Plug, Fusible	1
45	43147196	Bonnet, 1/4 IN 6.4	2
46	44246236	Tube, Capillary Bypass, 1.0x2.0x110L	1
47	44246239	Tube, Capillary ID 1.2	1
48	43047491	Tube, Capillary ID 1.5	1
49	43147529	Strainer	1
50	43149253	Rubber, Cushion	4
52	43049643	Cushion, Rubber	4
55	43047585	Strainer, Copper	3
56	43193059	Spring	1
57	43019822	Holder, Sensor	8
58	4311N641	Wiring Diagram	1
60	43157276	Heater, Case	1
61	43147640	Strainer	2

MMY-MP0601H8

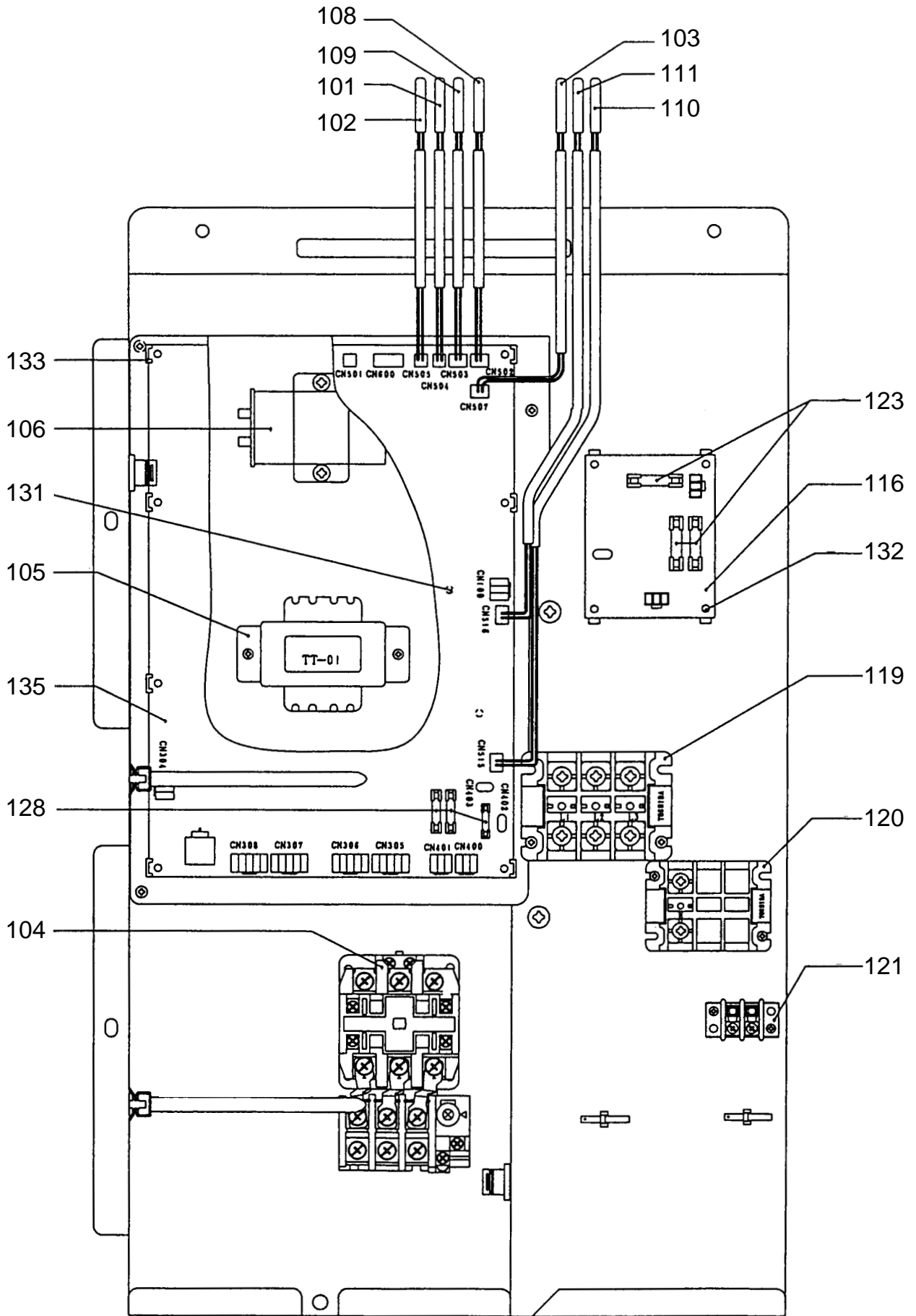

Location No.	Part No.	Description	Model name
			MMY-MP0601H8
101	43150230	Sensor	1
102	43150231	Sensor	1
103	43150239	Sensor	1
104	43152495	Connector, Magnetic AC220-240V	1
105	43158167	Transformer, Power TT-01, AC240V	1
106	43155167	Capacitor, MF 8 μ F/450V AC	1
108	43150290	Sensor	1
110	43150292	Sensor	1
111	43150293	Sensor	1
116	4316V100	PC Board Ass'y, Surge MCC-1357	1
119	43160503	Terminal Block, 3p, L1 L2 L3, 60A	1
120	43160449	Terminal, 3p AC600V 30A	1
121	43160445	Terminal Block, 2p 1A, AC30V	1
123	43160520	Fuse, 6A AC500V	3
128	43160522	Fuse, 6.3A AC250V	3
131	43163017	Supporter	4
132	43063240	Supporter, Ass'y	1
133	43063248	Supporter, Ass'y	2
135	4316V106	P.C. Board Ass'y, I/F-FIX, M	1

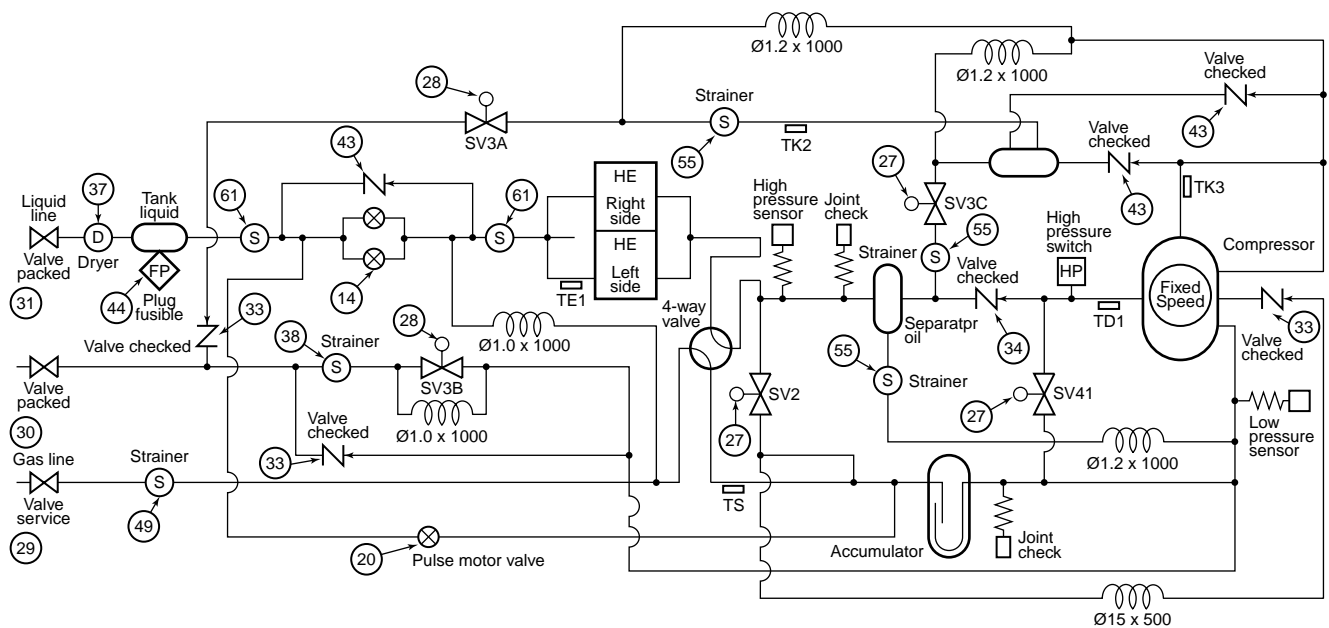

<Heat pump model>

MMY-MP0801HT7, MP1001HT7

MMY-MP0801H7, MP1001H7

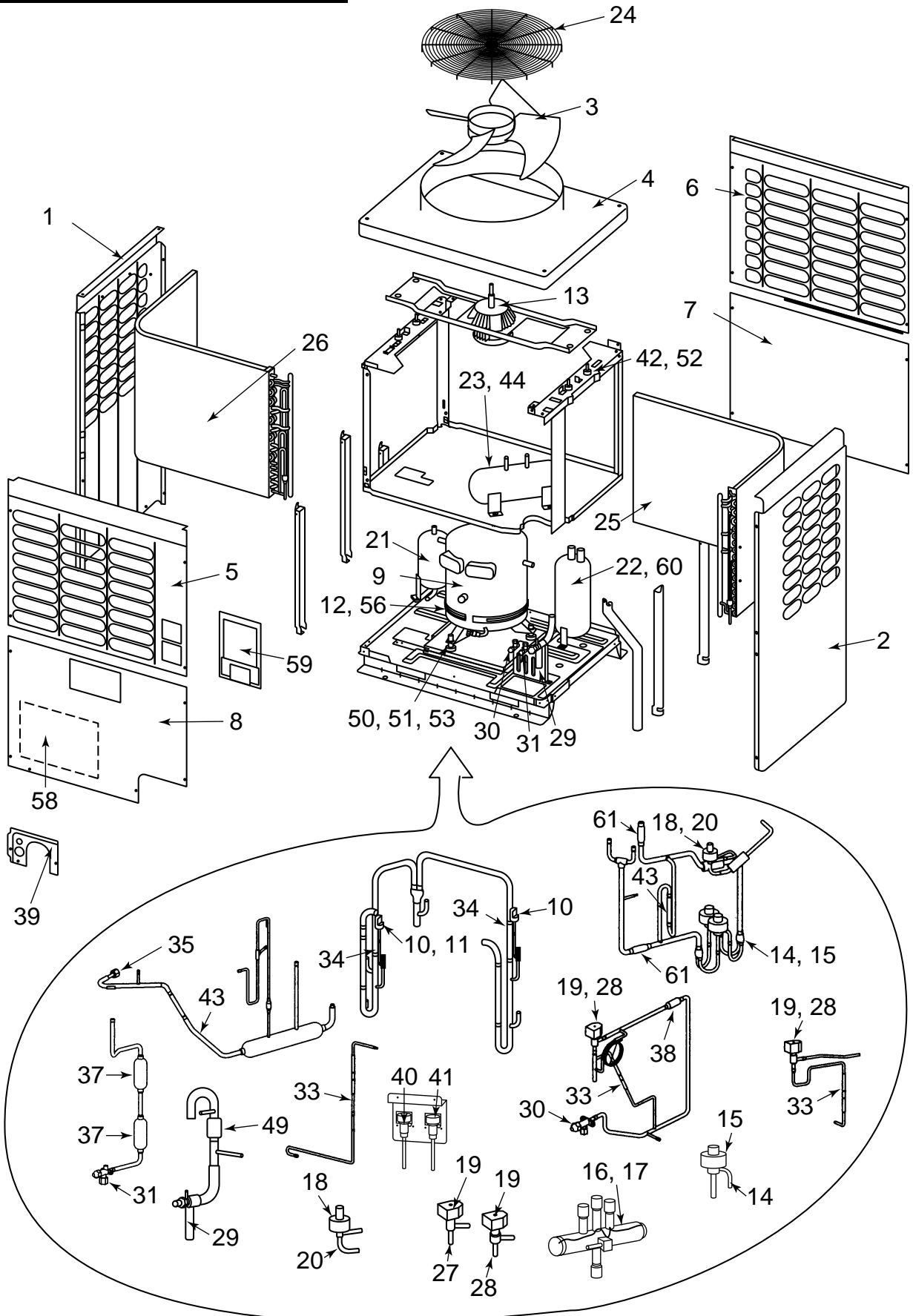

Location No.	Part No.	Description	Model name MMY-			
			MP0801HT7	MP1001HT7	MP0801H7	MP1001H7
1	43191594	Cabinet, Side Left	1	1	1	1
2	43191595	Cabinet, Side Right	1	1	1	1
3	43120203	Fan, Propeller DIA 630	1	1	1	1
4	43100209	Cabinet, UP	1	1	1	1
5	43191596	Cabinet, Front UP	1	1	1	1
6	43191597	Cabinet, Back UP	1	1	1	1
7	43191598	Cabinet, Back Down	1	1	1	1
8	43191599	Cabinet, Front Down	1	1	1	1
9	43141618	Compressor, MG1450CW-22B	1	1		
9	43141716	Compressor, YG1800CW-B2				1
9	43141717	Compressor, YG1700CW-B2			1	
10	43151264	Switch, High Pressure ACB-JA64	1	1	2	2
11	43151263	Switch, High Pressure ACB-JB128	1	1		
12	43157270	Heater, Crank Case			1	1
13	43121679	Motor, Fan STF-200-350A	1	1	1	1
14	43146520	Valve, Pulse Modulation	2	2	2	2
15	43146521	Coil, Pulse Motor Valve	2	2	2	2
16	43146537	Valve, 4-way				
17	43146611	Coil, Solenoid, VHV-01AJ502E1				
18	43146573	Coil, Pulse Motor Valve A12A15	1	1	1	1
19	43146612	Coil, Solenoid VPV-MOAJ524D0	5	5	6	6
20	43046377	Valve, Pulse Modulating, SEV18RC4	1	1	1	1
21	43148134	Separator, Oil	1	1	1	1
22	43148152	Accumulator	1	1	1	1
23	43148141	Tank, Liquid	1	1		
23	43148144	Tank, Liquid			1	1
24	43119444	Guard, Fan	1	1	1	1
25	4314G107	Condenser Ass'y	1	1	1	1
26	4314G108	Condenser Ass'y	1	1	1	1
27	43046151	Valve, 2-Way NEV202DXF	3	3	4	4
28	43046270	Valve, 2-Way NEV603DXF	2	2	2	2
29	43146518	Valve, Service	1	1	1	1
30	43046115	Valve, Packed 3/8 IN, 9.5DIA	1	1	1	1
31	43146378	Valve, Packed 1/2 IN	1	1	1	1
32	43146582	Joint, Check	2	2	2	2
33	43046581	Valve, Checked BCV-302DY	3	3	3	3
34	43146495	Valve, Checked BCV-804DY	1	1	2	2
35	43047546	Nut, Flare 3/8 IN	1	1	1	1
36	43194077	Socket, 1/8 IN	2	2	2	2
37	43145107	Dryer	2	2	2	2
38	43148151	Strainer	1	1	1	1
39	43191600	Panel, CGCD2-Z08-C77	1	1	1	1
40	43149276	Sensor Ass'y, Low Pressure 150NH4-L	1	1	1	1
41	43149277	Sensor Ass'y, High Pressure 150NH4-H	1	1	1	1
42	43097204	Nut	4	4	4	4
43	43146580	Valve, Checked YCV5-3SPTF-1	3	3	3	3
44	43148009	Plug, Fusible	1	1	1	1
45	43147196	Bonnet, 1/4 IN 6.4	2	2	2	2
46	44246236	Tube, Capillary Bypass, 1.0x2.0x110L	1	1	1	1
47	44246239	Tube, Capillary ID 1.2	1	1	1	1
48	43047527	Tube, Capillary ID 2.0x2000L	1	1	1	1
49	43147529	Strainer	1	1	1	1
50	43195185	Cushion, Under Compressor	3	3	3	3
51	43195186	Cushion, Under Compressor	3	3	3	3
52	43049643	Cushion, Rubber	4	4	4	4
53	43107200	Base, Spring	3	3	3	3
55	43047585	Strainer, Copper	3	3	3	3
56	43193058	Spring			1	1
57	43019822	Holder, Sensor	8	8	8	8
58	4311N639	Wiring Diagram	1	1		
58	4311N640	Wiring Diagram			1	1
59	4318T146	Owner's Manual	1	1		
60	43157276	Heater, Case	1	1	1	1
61	43147640	Strainer	2	2	2	2

MMY-MP0801HT7, MP1001HT7

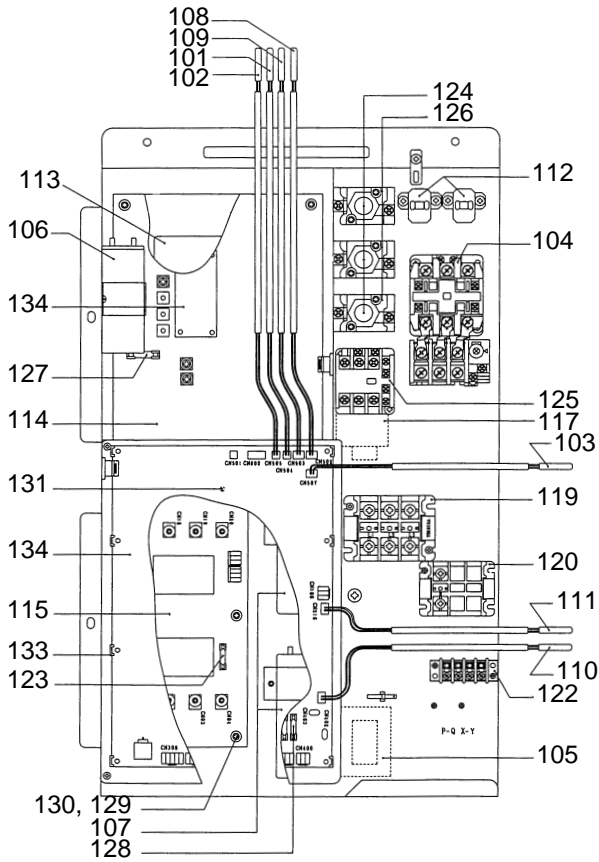

MMY-MP0801H7, MP1001H7

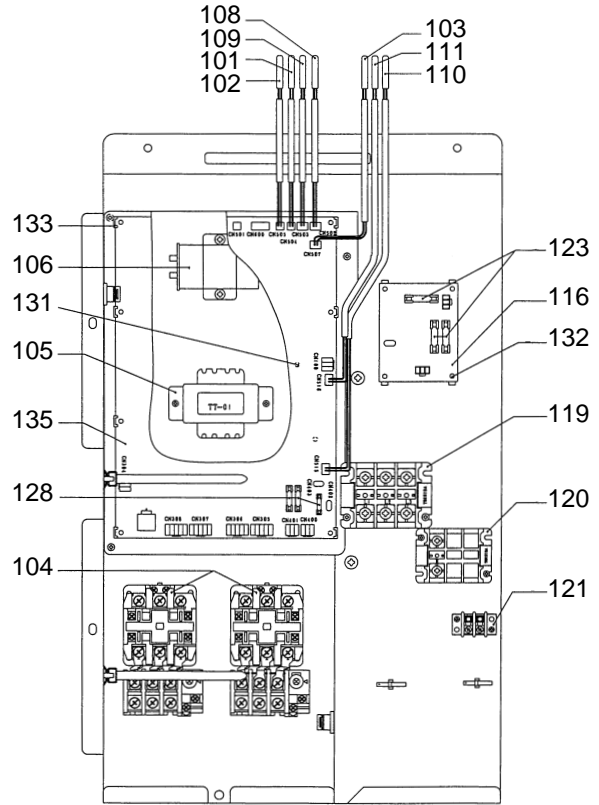

MMY-MP0801HT7, MP1001HT7

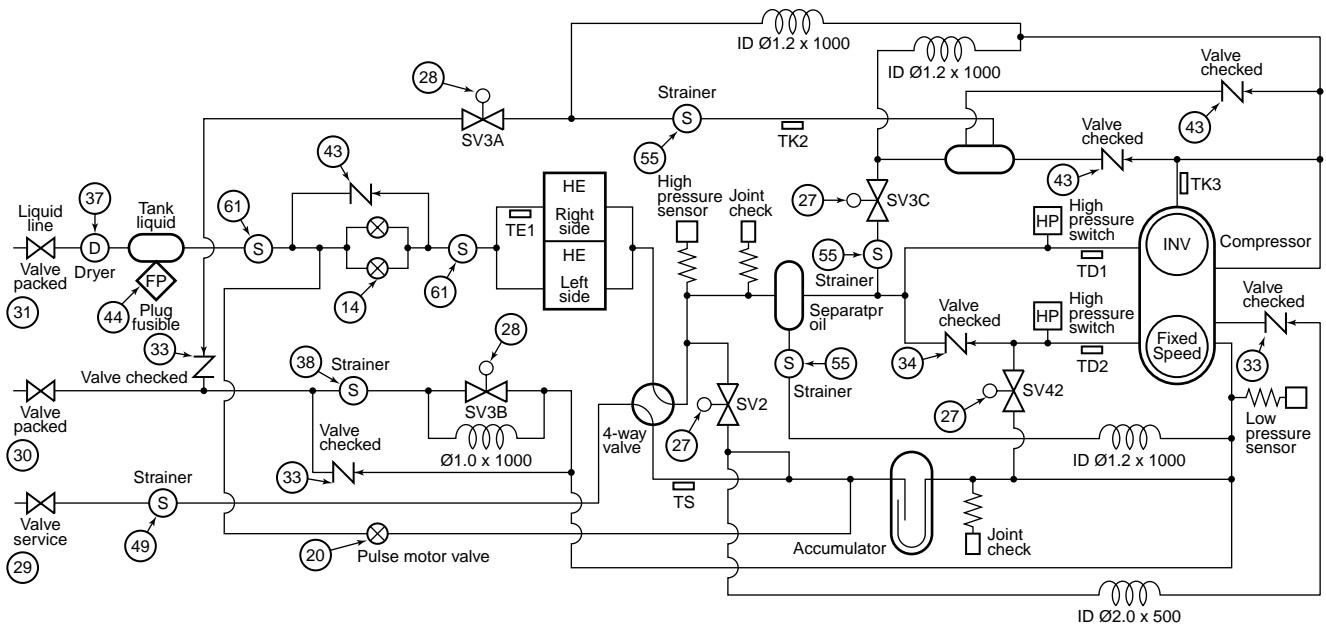

Location No.	Part No.	Description	Model name MMY-			
			MP0801HT7	MP1001HT7	MP0801H7	MP1001H7
101	43150230	Sensor	1	1	1	1
102	43150231	Sensor	1	1	1	1
103	43150239	Sensor	1	1	1	1
104	43152496	Connector, Magnetic AC220-240V	1	1	2	2
105	43158167	Transformer, Power TT-01, AC240V	1	1	1	1
106	43155177	Capacitor, MF 10 μ F/450V AC	1	1	1	1
107	43155168	Capacitor, Electrolytic 2200 μ F/400V	2	2		
108	43150290	Sensor	1	1	1	1
109	43150291	Sensor	1	1	1	1
110	43150292	Sensor	1	1	1	1
111	43150293	Sensor	1	1	1	1
112	43153006	PTC-Thermistor	2	2		
113	43163044	Heatsink	1	1		
114	4316V107	P.C. Board Ass'y, IPDU MCC-1342	1	1		
115	4316V104	P.C. Board Ass'y, N/F MCC-1366	1	1		
116	4316V100	P.C. Board Ass'y, Surge MCC-1357			1	1
117	43055475	Reactor, CH-25-Z	2	2		
118	43069889	Connector	1	1		
119	43160503	Terminal Block, 3p L1 L2 L3, 60A	1	1	1	1
120	43160449	Terminal, 3p AC600V 30A	1	1	1	1
121	43160445	Terminal Block, 2p 1A, AC30V			1	1
122	43160509	Terminal, 4p AC30V 1A	1	1		
123	43160520	Fuse, 6A AC500V	3	3	3	3
124	43160453	Fuse, 20A AC600V	3	3		
125	43152288	Connector, Magnetic 50H8 230V	1	1		
126	43160451	Holder, Fuse AC600V 30A	3	3		
127	43160521	Fuse, 3.15A AC250V	1	1		
128	43160522	Fuse, 6.3A AC250V	3	3	3	3
129	43282001	Bushing, NB-300	10	10		
130	43183020	Collar, NA-310	10	10		
131	43163017	Supporter	4	4	4	4
132	43063240	Supporter, Ass'y			1	1
133	43063248	Supporter, Ass'y	2	2	2	2
134	4316V105	P.C. Board Ass'y, I/F-INV MCC-1343	1	1		
135	4316V106	P.C. Board Ass'y, I/F-FIX MCC-1343			1	1

MMY-MP0801H7, MP1001H7

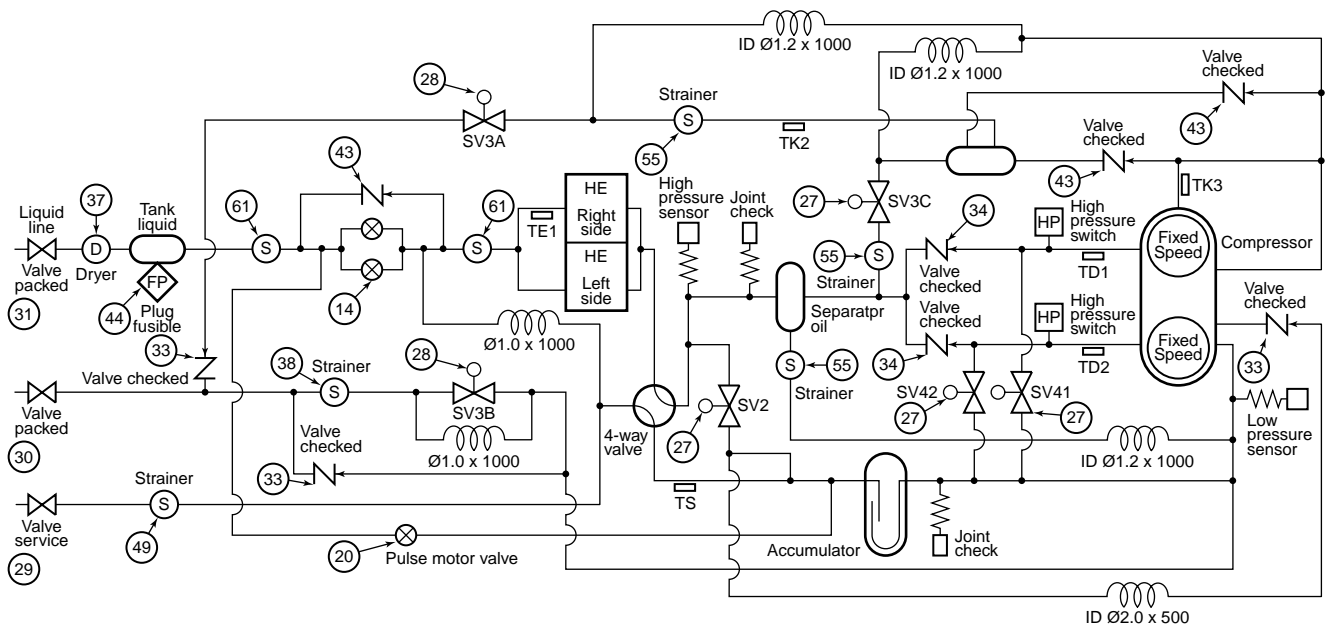

<Heat Pump model>

MMY-MP0601H7

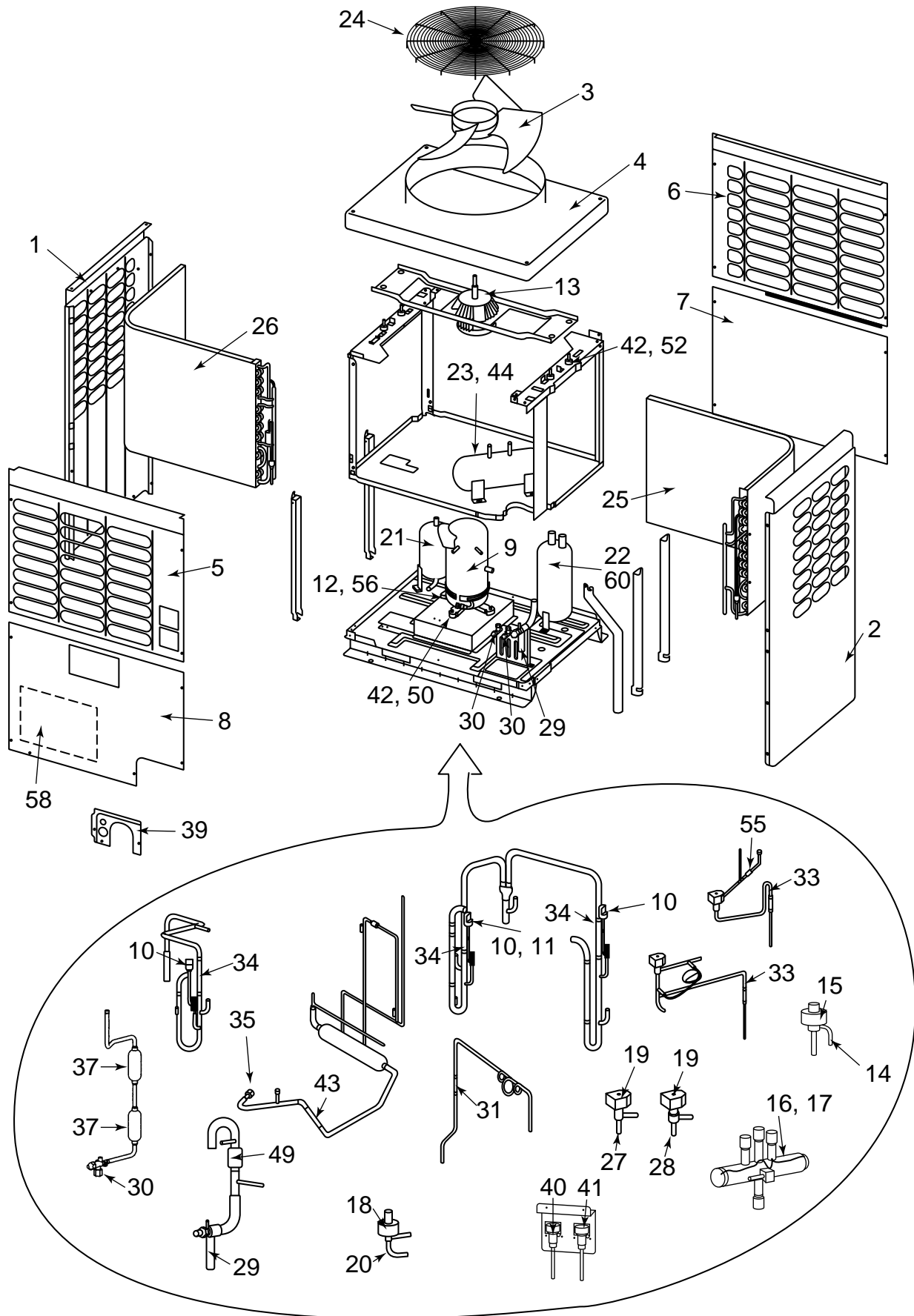

Location No.	Part No.	Description	Model name
			MMY-MP0601H7
1	43191594	Cabinet, Side Left	1
2	43191595	Cabinet, Side Right	1
3	43120203	Fan, Propeller DIA 630	1
4	43100209	Cabinet, UP	1
5	43191596	Cabinet, Front UP	1
6	43191597	Cabinet, Back UP	1
7	43191598	Cabinet, Back Down	1
8	43191599	Cabinet, Front Down	1
9	43141402	Compressor, YG890C-3B	1
10	43151264	Switch, High Pressure, ACB-JA64	1
12	43157271	Heater, Crank Case AC 240V 40W	1
13	43121679	Motor, Fan STF-200-350A	1
14	43146520	Valve, Pulse Modulation	1
15	43146521	Coil, Pulse Motor Valve	1
16	43146499	Valve 4-way, CHV-0401	
17	43146611	Coil, Solenoid, VHV-01AJ502E1	
18	43146573	Coil, Pulse Motor Valve A12A15	1
19	43146612	Coil, Solenoid VPV-MOAJ514D0	5
20	43046377	Valve, Pulse Modulating, SEV18RC4	1
21	43148134	Separator, Oil	1
22	43148152	Accumulator	1
23	43148144	Tank, Liquid	1
24	43119444	Guard, Fan	1
25	4314G110	Condenser Ass'y	1
26	4314G109	Condenser Ass'y	1
27	43046151	Valve, 2-Way NEV202DXF	3
28	43046270	Valve, 2-Way NEV603DXF	2
29	43146518	Valve, Service	1
30	43046115	Valve, Packed 3/8 IN, 9.5DIA	2
32	43146582	Joint, Check	2
33	43146581	Valve, Checked BCV-302DY	3
34	43146495	Valve, Checked BCV-804DY	1
35	43047546	Nut, Flare 3/8 IN	1
36	43194077	Socket, 1/8 IN	2
37	43145107	Dryer	2
38	43148151	Strainer	1
39	43191600	Panel, CGCD2-Z08-C77	1
40	43149276	Sensor Ass'y, Low Pressure 150NH4-L	1
41	43149277	Sensor Ass'y, High Pressure 150NH4-H	1
42	43097204	Nut	8
43	43146580	Valve, Checked YCV5-3SPTF-1	3
44	43048171	Plug, Fusible	1
45	43147196	Bonnet, 1/4 IN 6.4	2
46	44246236	Tube, Capillary Bypass, 1.0x2.0x110L	1
47	44246239	Tube, Capillary ID 1.2	1
48	43047491	Tube, Capillary ID 1.5	1
49	43147529	Strainer	1
50	43149253	Rubber, Cushion	4
52	43049643	Cushion, Rubber	4
55	43047585	Strainer, Copper	3
56	43193059	Spring	1
57	43019822	Holder, Sensor	8
58	4311N641	Wiring Diagram	1
60	43157276	Heater, Case	1
61	43147640	Strainer	2

MMY-MP0601H7

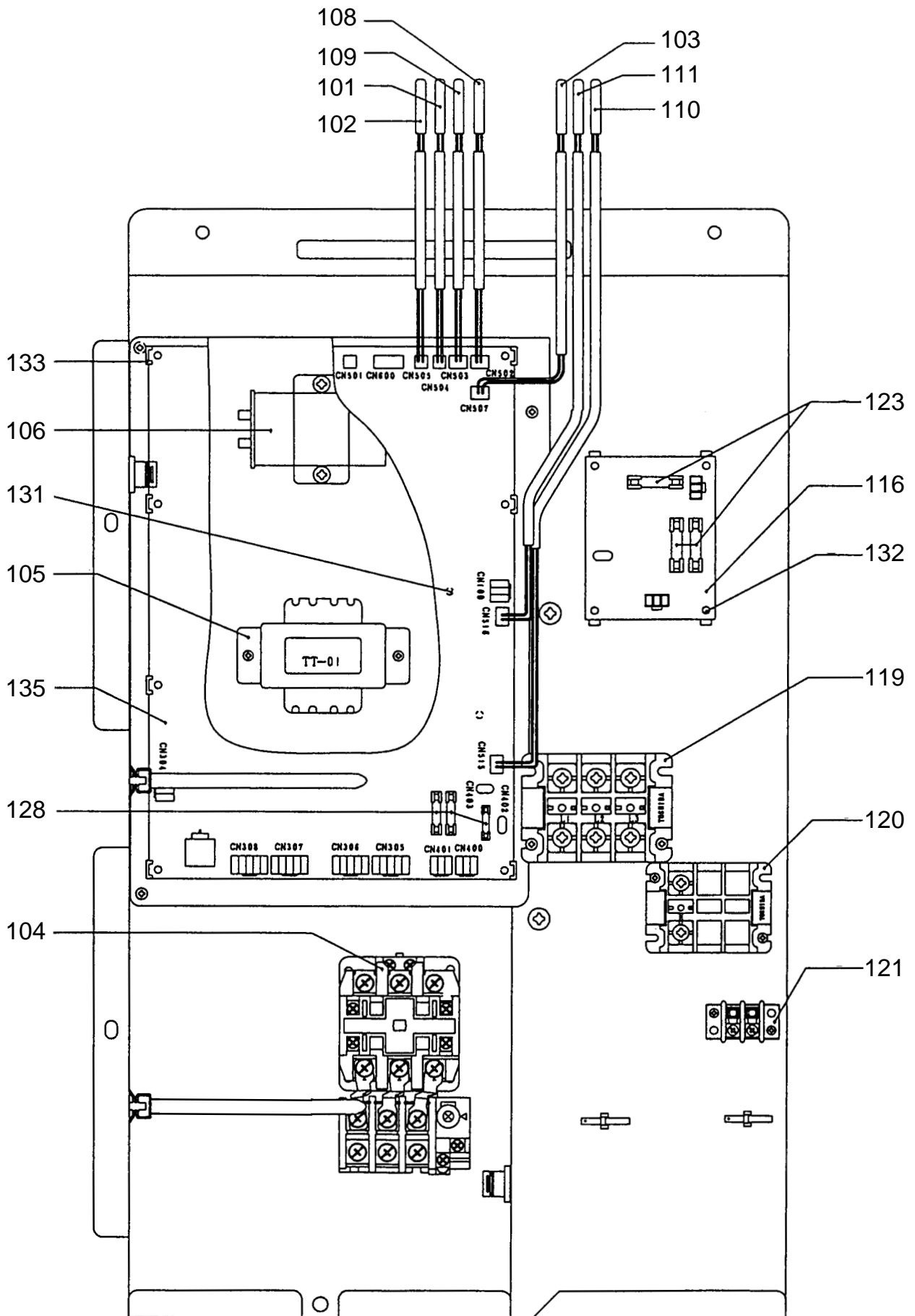

100Locat ion No.	Part No.	Description	Model name
			MMY-MP0601H7
101	43150230	Sensor	1
102	43150231	Sensor	1
103	43150239	Sensor	1
104	43152496	Connector, Magnetic AC220-240V	1
105	43158167	Transformer, Power TT-01, AC240V	1
106	43155177	Capacitor, MF 10 μ F/450V AC	1
108	43150290	Sensor	1
110	43150292	Sensor	1
111	43150293	Sensor	1
116	4316V100	PC Board Ass'y, Surge MCC-1357	1
119	43160503	Terminal Block, 3p, L1 L2 L3, 60A	1
120	43160449	Terminal, 3p AC600V 30A	1
121	43160445	Terminal Block, 2p 1A, AC30V	1
123	43160520	Fuse, 6A AC500V	3
128	43160522	Fuse, 6.3A AC250V	3
131	43163017	Supporter	4
132	43063240	Supporter, Ass'y	1
133	43063248	Supporter, Ass'y	2
135	4316V106	P.C. Board Ass'y, I/F-FIX, M	1

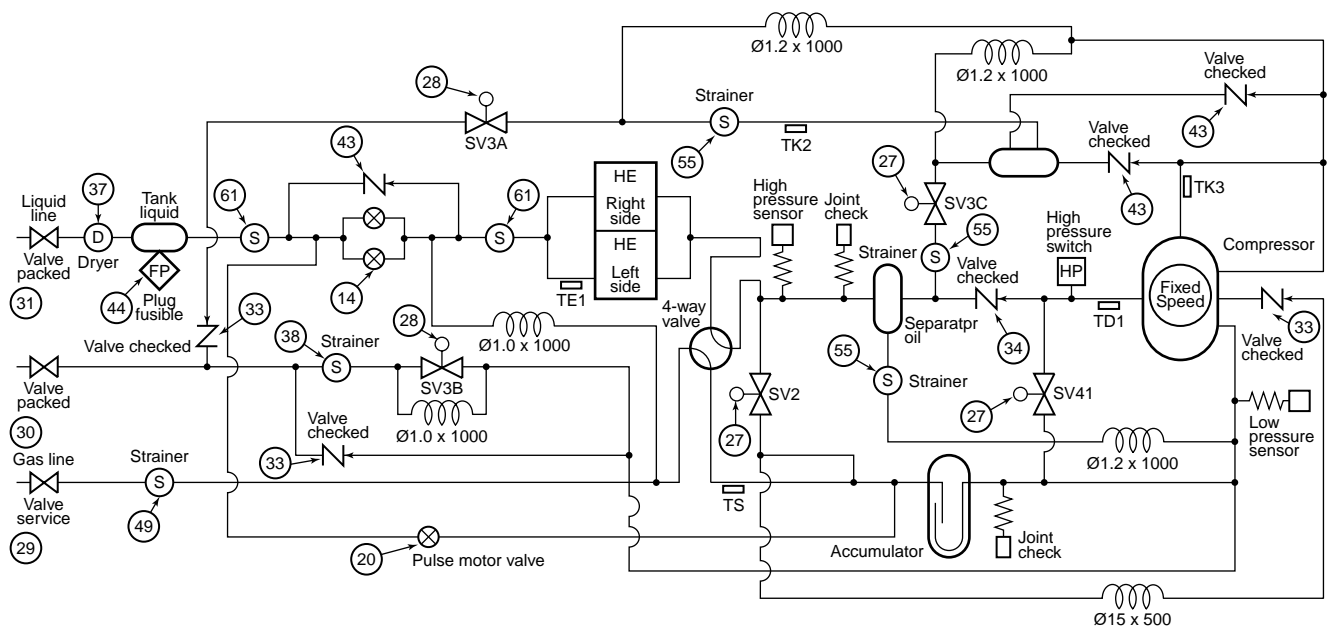

TOSHIBA CARRIER CORPORATION
336 TADEHARA FUJI-SHI, SHIZUOKA-KEN, 416-8521, JAPAN