

TOSHIBA

SERVICE MANUAL

FILE NO. SVM-06012

AIR-CONDITIONER

UNDER CEILING / CONSOLE TYPE

RAV-SM562XT-E / RAV-SM562AT-E
RAV-SM802XT-E / RAV-SM802AT-E

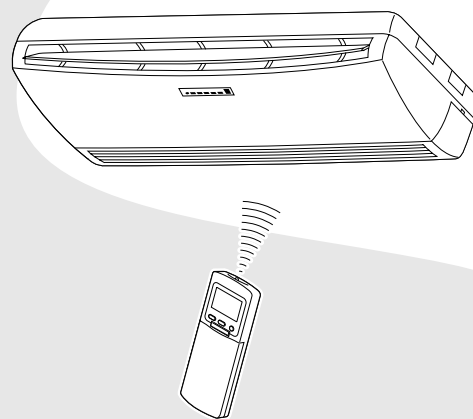

CONTENTS

1. SPECIFICATIONS.....	1
2. CONSTRUCTION VIEWS	3
3. SYSTEMATIC REFRIGERATING CYCLE DIAGRAM	4
4. WIRING DIAGRAM	5
5. SPECIFICATION OF ELECTRICAL PARTS	6
6. REFRIGERANT R410A	7
7. CONTROL BLOCK DIAGRAM	15
8. OPERATION DESCRIPTION	16
9. TROUBLESHOOTING CHART	21
10. DETACHMENTS	27
11. EXPLODED VIEWS AND PARTS LIST	32

Note :

This Service Manual describes explanation for the Under Ceiling 1 console type indoor unit.

For the combined outdoor unit, refer to the following Service Manual.

Outdoor unit Model name	SVM to be referred
RAV-SMXX0AT-E	A03-007
RAV-SPXXXAT-E	A03-014
RAV-SMXX1AT-E	A05-001
RAV-SMXX2AT-E	A05-018

1. SPECIFICATIONS

1-1. Indoor Unit (Flexi Type)

Model	Indoor unit		RAV-SM562XT-E	RAV-SM802XT-E	
	Outdoor unit		RAV-SM562AT-E	RAV-SM802AT-E	
Cooling capacity		(kW)	5.0	6.7	
Heating capacity		(kW)	5.6	8.0	
Power supply			1 phase 230V (220-240V) 50Hz		
Electrical characteristics	Cooling	Running current	(A)	8.95-8.20	13.15-12.06
		Power consumption	(kW)	1.87	2.72
		Power factor	(%)	95	94
		EER	(W/W)	2.67	2.46
		Energy efficiency class *		D	E
	Energy rating *		2.5	1.5	
	Heating	Running current	(A)	8.13-7.46	12.91-11.84
		Power consumption	(kW)	1.70	2.67
		Power factor	(%)	95	94
		COP	(W/W)	3.29	3.00
Energy efficiency class *			C	D	
Energy rating *		3.0	2.5		
Appearance	Main unit		Pure white		
	Ceiling panel (Sold separately)	Model	-		
		Panel color	-		
Outer dimension	Main unit	Height	(mm)	208	208
		Width	(mm)	1093	1093
		Depth	(mm)	633	633
	Ceiling panel (Sold separately)	Height	(mm)	-	-
		Width	(mm)	-	-
		Depth	(mm)	-	-
Total weight	Main unit		(kg)	23	23
	Ceiling panel		(kg)	-	-
Heat exchanger			Finned tube		
Fan unit	Fan		Centrifugal		
	Standard air flow	H/M/L (m ³ /h)	14.0 / 12.0 / 10.0	18.5 / 13.5 / 10.7	
	Motor		(W)	50	50
Air filter			Attached main unit		
Controller			Attached main unit (WH-H2UE)		
Dimensions pipe	Gas side	(mm)	□ 12.7	□ 15.9	
	Liquid side	(mm)	□ 6.4	□ 9.5	
	Drain port		(mm)	VP16	
Sound level		H/M/L (dB(A))	43 / 39 / 36	46 / 42 / 37	
Sound power level		H/M/L (dB(A))	58 / 54 / 51	61 / 57 / 52	

* IEC standard

** AS standard

• Operation characteristic curve

<Cooling>

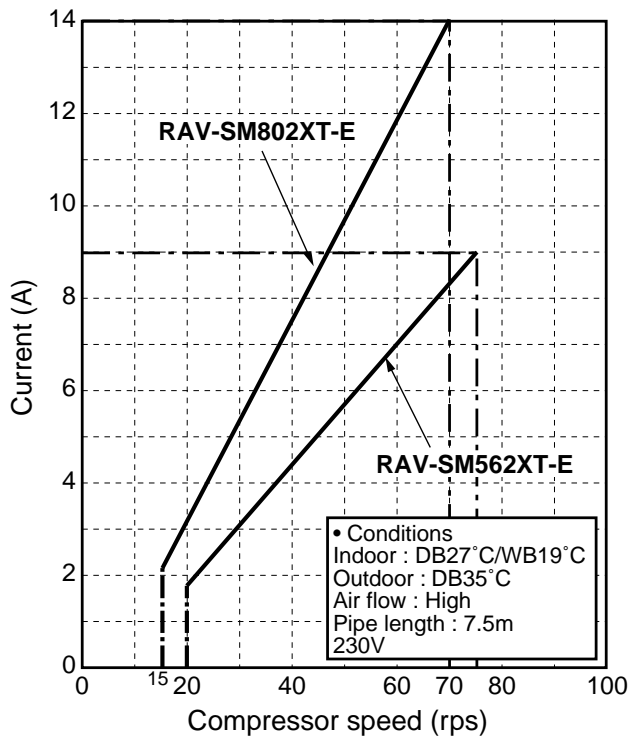

<Heating>

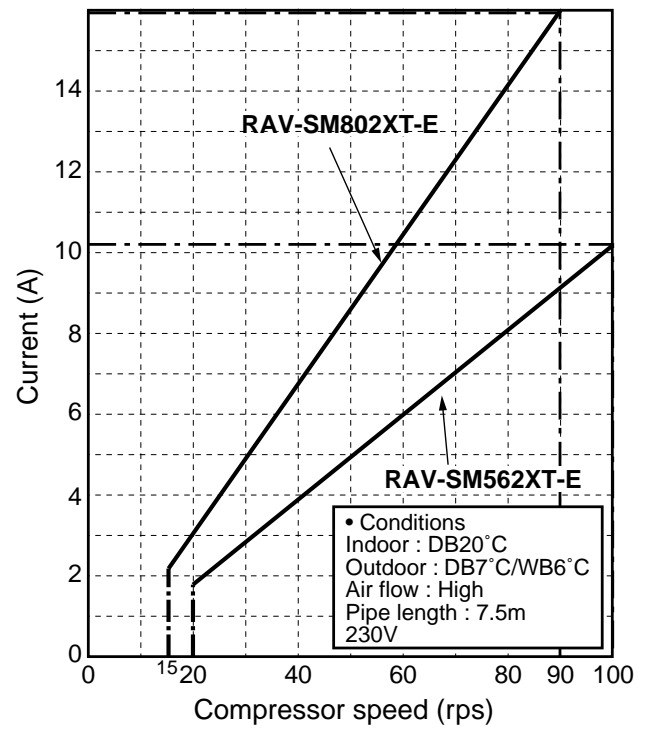

• Capacity variation ratio according to temperature

<Cooling>

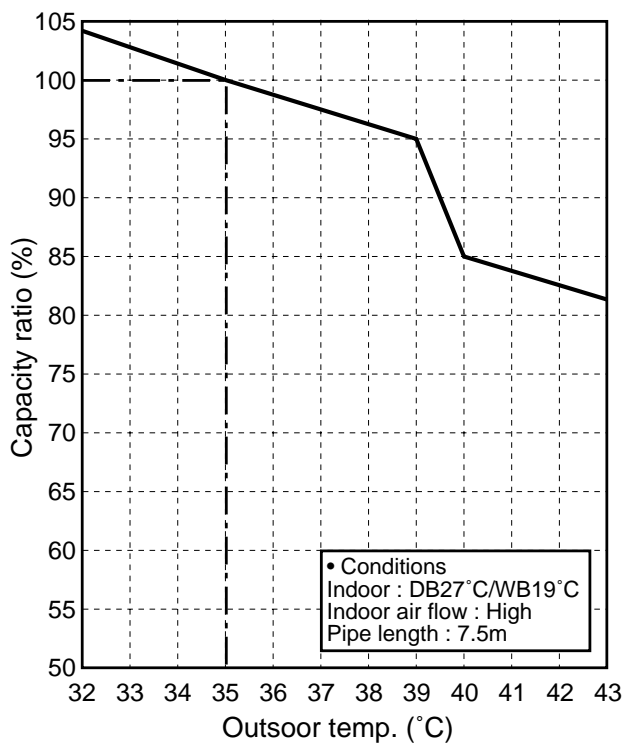

<Heating>

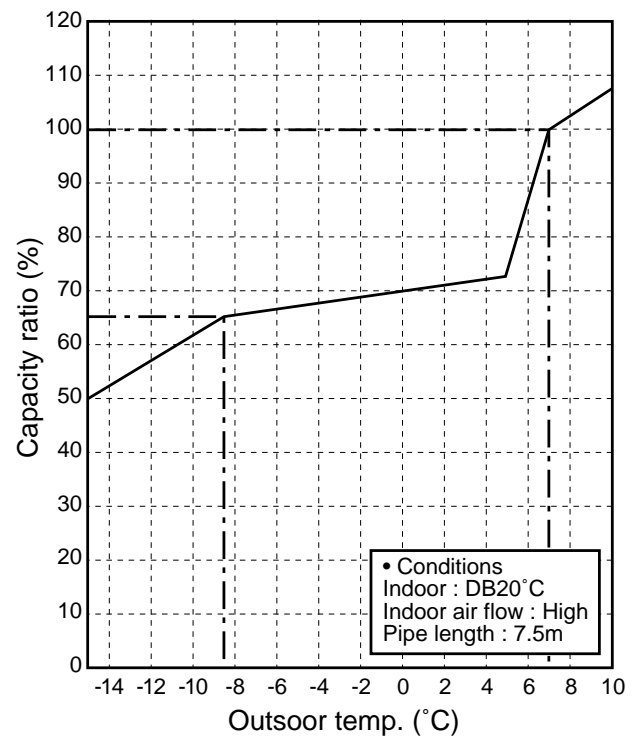

2. CONSTRUCTION VIEWS

2-1. Indoor Unit

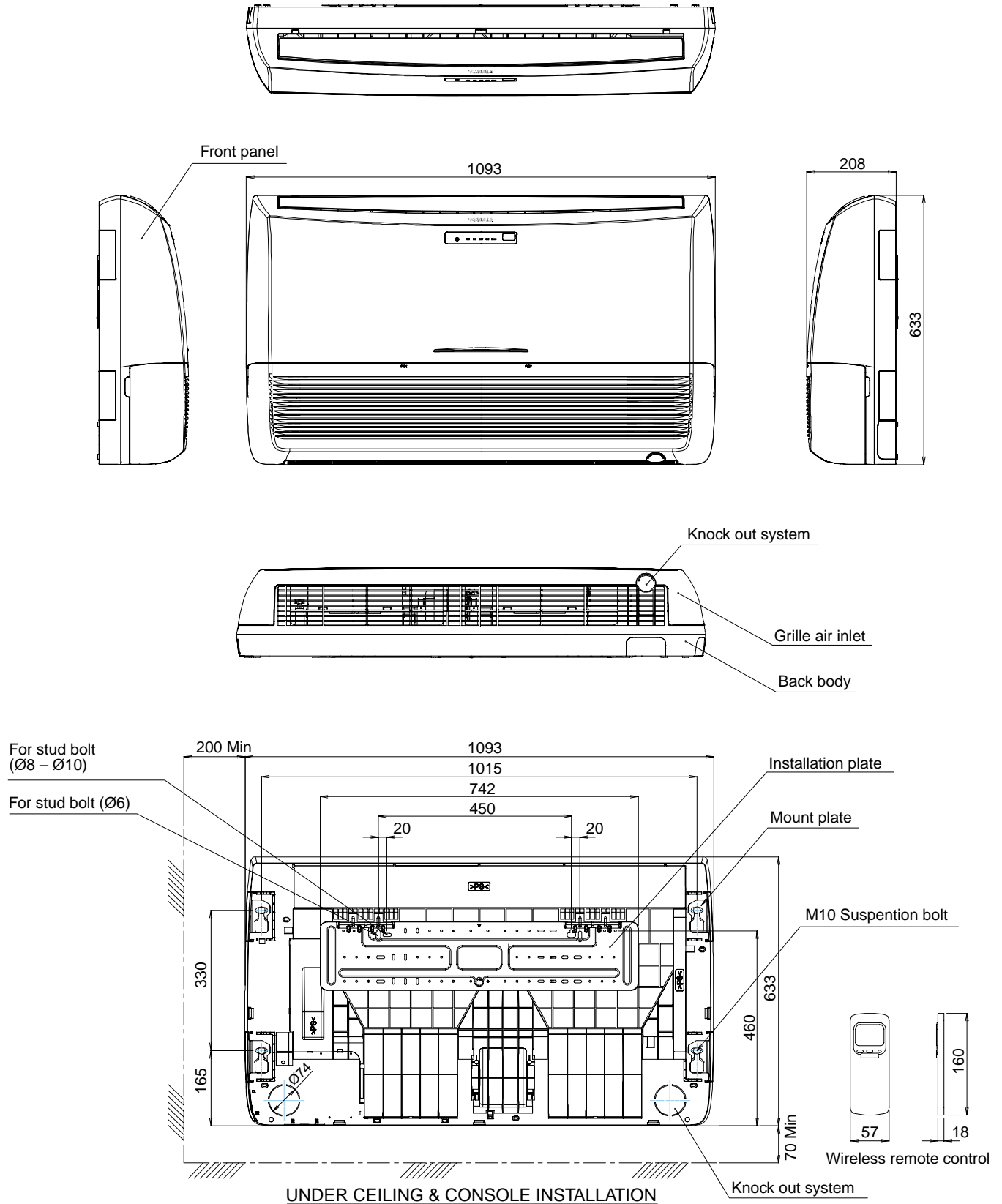

3. SYSTEMATIC REFRIGERATING CYCLE DIAGRAM

3-1. RAV-SM562XT-E / RAV-SM802XT-E

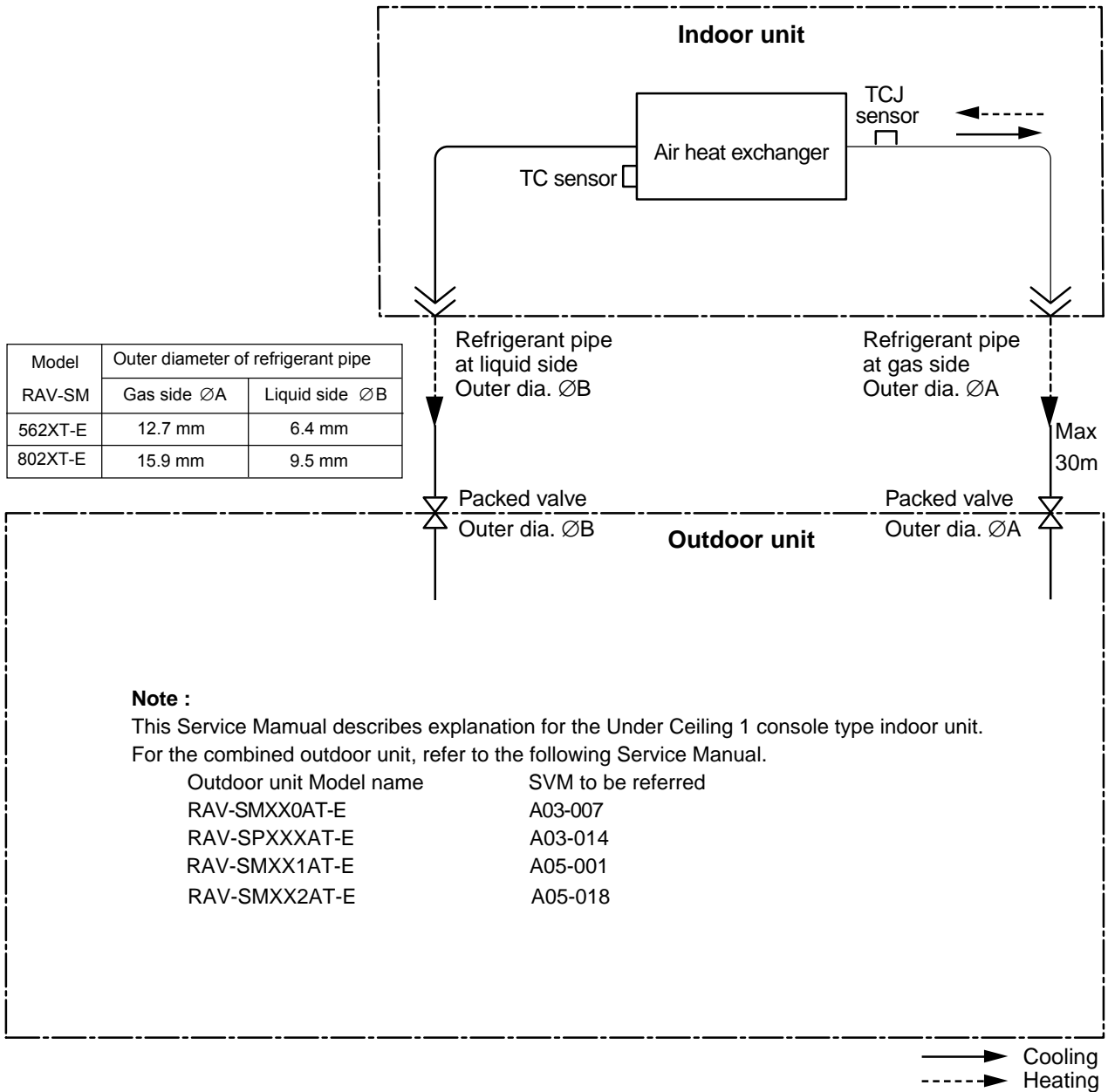

4. WIRING DIAGRAM

Indoor Unit

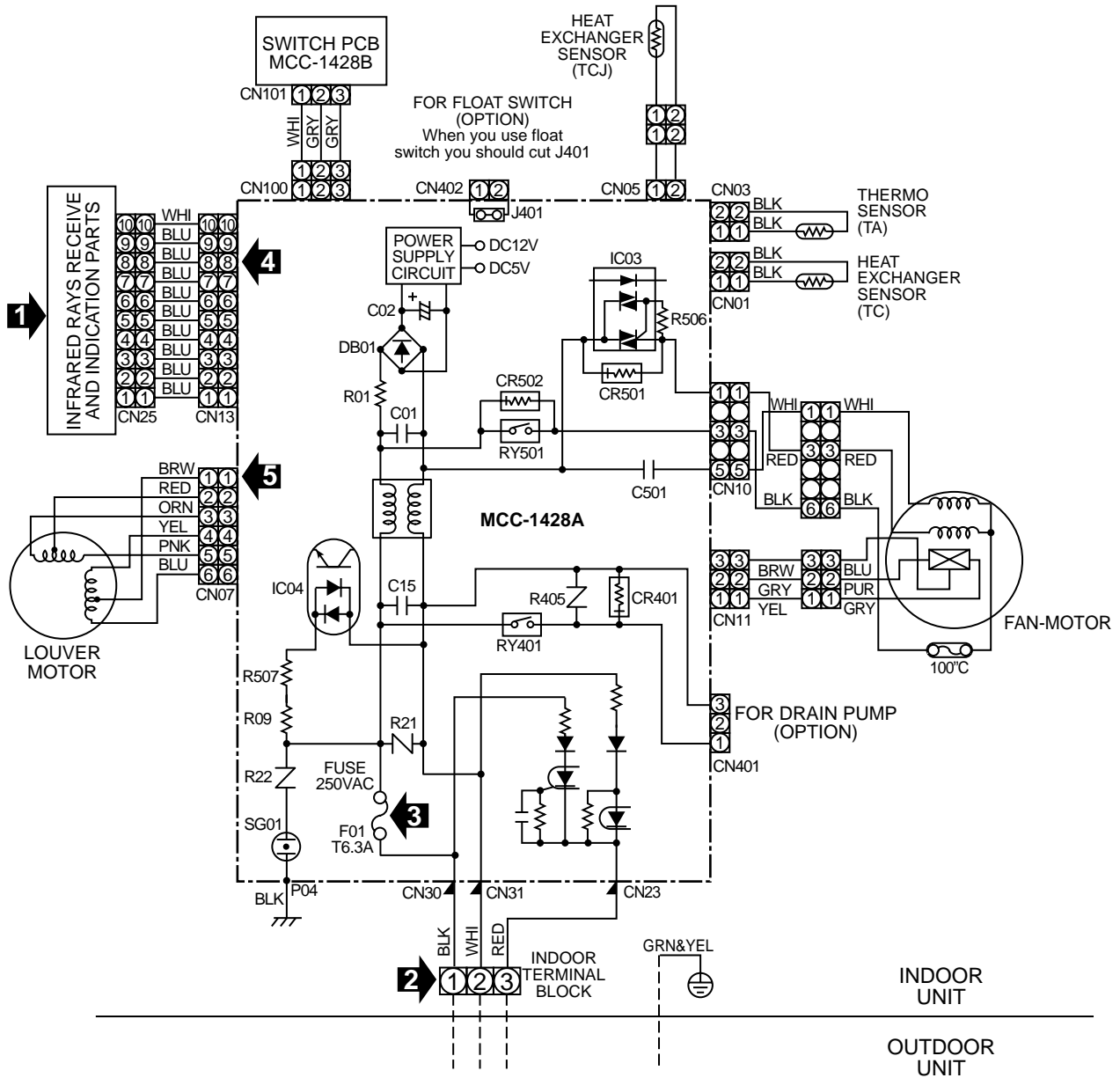

SIMPLE CHECK POINTS FOR DIAGNOSING FAULTS

Check items	Diagnosis result	Color Identification
1 OPERATION indicator	Check to see if OPERATION indicator goes on and off when the main switch or breaker is turned on.	
2 Terminal block	Check the power supply voltage between ① - ② (Refer to the name plate.) Check the fluctuate voltage between ② - ③ (DC15 to 60V)	BRW : BROWN RED : RED WHI : WHITE YEL : YELLOW BLU : BLUE BLK : BLACK GRY : GRAY PNK : PINK ORN : ORANGE GRN&YEL : GREEN & YELLOW GRN : GREEN PUR : PURPLE
3 Fuse 6.3A	Check to see if the fuse blows out. (Check the varistor. : R22, R21)	
4 DC 5V	Check the voltage at the No.8 pin on CN13 connector of the infrared receiver. (Check the transformer and the power supply circuit of the rated voltage.)	
5 DC 12V	Check the voltage at the brown lead of the louver motor. (Check the transformer and the power supply circuit of the rated voltage.)	

5. SPECIFICATION OF ELECTRICAL PARTS

Indoor Unit

No.	Parts name	Type	Specifications
1	Fan motor (for indoor)	AFP-220-50-4A	Output (Rated) 50 W, 220 – 240 V
2	Grille motor	MP35EA	DC 12 V
3	Thermo. sensor (TA-sensor)	550 mm	10 k Ω at 25°C
4	Heat exchanger sensor (TC-sensor)	Ø6 mm, 500 mm	10 k Ω at 25°C
5	Heat exchanger sensor (TCJ-sensor)	Ø6 mm, 500 mm	10 k Ω at 25°C

6. REFRIGERANT R410A

This air conditioner adopts the new refrigerant HFC (R410A) which does not damage the ozone layer.

The working pressure of the new refrigerant R410A is 1.6 times higher than conventional refrigerant (R22). The refrigerating oil is also changed in accordance with change of refrigerant, so be careful that water, dust, and existing refrigerant or refrigerating oil are not entered in the refrigerant cycle of the air conditioner using the new refrigerant during installation work or servicing time.

The next section describes the precautions for air conditioner using the new refrigerant. Conforming to contents of the next section together with the general cautions included in this manual, perform the correct and safe work.

6-1. Safety During Installation/Serviceing

As R410A's pressure is about 1.6 times higher than that of R22, improper installation/servicing may cause a serious trouble. By using tools and materials exclusive for R410A, it is necessary to carry out installation/servicing safely while taking the following precautions into consideration.

- (1) Never use refrigerant other than R410A in an air conditioner which is designed to operate with R410A.
If other refrigerant than R410A is mixed, pressure in the refrigeration cycle becomes abnormally high, and it may cause personal injury, etc. by a rupture.
- (2) Confirm the used refrigerant name, and use tools and materials exclusive for the refrigerant R410A. The refrigerant name R410A is indicated on the visible place of the outdoor unit of the air conditioner using R410A as refrigerant. To prevent mischarging, the diameter of the service port differs from that of R22
- (3) If a refrigeration gas leakage occurs during installation/servicing, be sure to ventilate fully. If the refrigerant gas comes into contact with fire, a poisonous gas may occur.
- (4) When installing or removing an air conditioner, do not allow air or moisture to remain in the refrigeration cycle. Otherwise, pressure in the refrigeration cycle may become abnormally high so that a rupture of personal injury may be caused.

- (5) After completion of installation work, check to make sure that there is no refrigeration gas leakage.
If the refrigerant gas leaks into the room, coming into contact with fire in the fan-driven heater, space heater, etc., a poisonous gas may occur.
- (6) When an air conditioning system charged with a large volume of refrigerant is installed in a small room, it is necessary to exercise care so that, even when refrigerant leaks, its concentration does not exceed the marginal level.
If the refrigerant gas leakage occurs and its concentration exceeds the marginal level, an oxygen starvation accident may result.
- (7) Be sure to carry out installation or removal according to the installation manual.
Improper installation may cause refrigeration trouble, water leakage, electric shock, fire, etc.
- (8) Unauthorized modifications to the air conditioner may be dangerous. If a breakdown occurs please call a qualified air conditioner technician or electrician.
Improper repair's may result in water leakage, electric shock and fire, etc.

6-2. Refrigerant Piping Installation

6-2-1. Piping materials and joints used

For the refrigerant piping installation, copper pipes and joints are mainly used. Copper pipes and joints suitable for the refrigerant must be chosen and installed. Furthermore, it is necessary to use clean copper pipes and joints whose interior surfaces are less affected by contaminants.

- (1) Copper pipes
It is necessary to use seamless copper pipes which are made of either copper or copper alloy and it is desirable that the amount of residual oil is less than 40 mg/10 m. Do not use copper pipes having a collapsed, deformed or discolored portion (especially on the interior surface). Otherwise, the expansion valve or capillary tube may become blocked with contaminants.
As an air conditioner using R410A incurs pressure higher than when using R22, it is necessary to choose adequate materials.
Thicknesses of copper pipes used with R410A are as shown in Table 6-2-1. Never use copper pipes thinner than 0.8 mm even when it is available on the market.

Table 6-2-1 Thicknesses of annealed copper pipes

		Thickness (mm)	
Nominal diameter	Outer diameter (mm)	R410A	R22
1/4	6.35	0.80	0.80
3/8	9.52	0.80	0.80
1/2	12.70	0.80	0.80
5/8	15.88	1.00	1.00

(2) Joints

For copper pipes, flare joints or socket joints are used. Prior to use, be sure to remove all contaminants.

a) Flare joints

Flare joints used to connect the copper pipes cannot be used for pipings whose outer diameter exceeds 20 mm. In such a case, socket joints can be used.

Sizes of flare pipe ends, flare joint ends and flare nuts are as shown in Tables 6-2-3 to 6-2-6 below.

b) Socket joints

Socket joints are such that they are brazed for connections, and used mainly for thick pipings whose diameter is larger than 20 mm.

Thicknesses of socket joints are as shown in Table 6-2-2.

Table 6-2-2 Minimum thicknesses of socket joints

Nominal diameter	Reference outer diameter of copper pipe jointed (mm)	Minimum joint thickness (mm)
1/4	6.35	0.50
3/8	9.52	0.60
1/2	12.70	0.70
5/8	15.88	0.80

6-2-1. Processing of piping materials

When performing the refrigerant piping installation, care should be taken to ensure that water or dust does not enter the pipe interior, that no other oil other than lubricating oils used in the installed air conditioner is used, and that refrigerant does not leak. When using lubricating oils in the piping processing, use such lubricating oils whose water content has been removed. When stored, be sure to seal the container with an airtight cap or any other cover.

(1) Flare Processing procedures and precautions**a) Cutting the pipe**

By means of a pipe cutter, slowly cut the pipe so that it is not deformed.

b) Removing burrs and chips

If the flared section has chips or burrs, refrigerant leakage may occur. Carefully remove all burrs and clean the cut surface before installation.

c) Insertion of flare nut**d) Flare processing**

Make certain that a clamp bar and copper pipe have been cleaned.

By means of the clamp bar, perform the flare processing correctly.

Use either a flare tool for R410A or conventional flare tool.

Flare processing dimensions differ according to the type of flare tool. When using a conventional flare tool, be sure to secure "dimension A" by using a gauge for size adjustment.

**Fig. 6-2-1 Flare processing dimensions**

Table 6-2-3 Dimensions related to flare processing for R410A

Nominal diameter	Outer diameter (mm)	Thickness (mm)	A (mm)		
			Flare tool for R410A clutch type	Conventional flare tool	
				Clutch type	Wing nut type
1/4	6.35	0.8	0 to 0.5	1.0 to 1.5	1.5 to 2.0
3/8	9.52	0.8	0 to 0.5	1.0 to 1.5	1.5 to 2.0
1/2	12.70	0.8	0 to 0.5	1.0 to 1.5	2.0 to 2.5
5/8	15.88	1.0	0 to 0.5	1.0 to 1.5	2.0 to 2.5

Table 6-2-4 Dimensions related to flare processing for R22

Nominal diameter	Outer diameter (mm)	Thickness (mm)	A (mm)		
			Flare tool for R22 clutch type	Conventional flare tool	
				Clutch type	Wing nut type
1/4	6.35	0.8	0 to 0.5	0.5 to 1.0	1.0 to 1.5
3/8	9.52	0.8	0 to 0.5	0.5 to 1.0	1.0 to 1.5
1/2	12.70	0.8	0 to 0.5	0.5 to 1.0	1.5 to 2.0
5/8	15.88	1.0	0 to 0.5	0.5 to 1.0	1.5 to 2.0

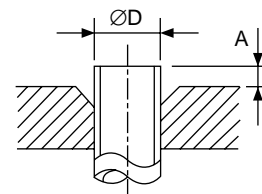
Table 6-2-5 Flare and flare nut dimensions for R410A

Nominal diameter	Outer diameter (mm)	Thickness (mm)	Dimension (mm)				Flare nut width (mm)
			A	B	C	D	
1/4	6.35	0.8	9.1	9.2	6.5	13	17
3/8	9.52	0.8	13.2	13.5	9.7	20	22
1/2	12.70	0.8	16.6	16.0	12.9	23	26
5/8	15.88	1.0	19.7	19.0	16.0	25	29

Table 6-2-6 Flare and flare nut dimensions for R22

Nominal diameter	Outer diameter (mm)	Thickness (mm)	Dimension (mm)				Flare nut width (mm)
			A	B	C	D	
1/4	6.35	0.8	9.0	9.2	6.5	13	17
3/8	9.52	0.8	13.0	13.5	9.7	20	22
1/2	12.70	0.8	16.2	16.0	12.9	20	24
5/8	15.88	1.0	19.4	19.0	16.0	23	27
3/4	19.05	1.0	23.3	24.0	19.2	34	36

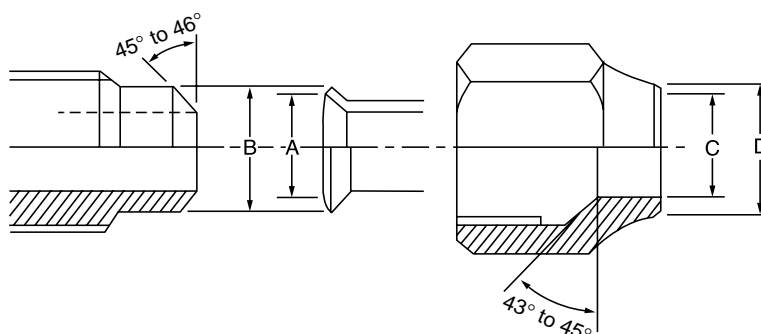

Fig. 6-2-2 Relations between flare nut and flare seal surface

(2) Flare connecting procedures and precautions

- a) Make sure that the flare and union portions do not have any scar or dust, etc.
- b) Correctly align the processed flare surface with the union axis.
- c) Tighten the flare with designated torque by means of a torque wrench. The tightening torque for R410A is the same as that for conventional R22. Incidentally, when the torque is weak, the gas leakage may occur.

When it is strong, the flare nut may crack and may be made non-removable. When choosing the tightening torque, comply with values designated by manufacturers. Table 6-2-7 shows reference values.

Note:

When applying oil to the flare surface, be sure to use oil designated by the manufacturer. If any other oil is used, the lubricating oils may deteriorate and cause the compressor to burn out.

Table 6-2-7 Tightening torque of flare for R410A [Reference values]

Nominal diameter	Outer diameter (mm)	Tightening torque N·m (kgf·cm)	Tightening torque of torque wrenches available on the market N·m (kgf·m)
1/4	6.35	14 to 18 (140 to 180)	16 (160), 18 (180)
3/8	9.52	33 to 42 (330 to 420)	42 (420)
1/2	12.70	50 to 62 (500 to 620)	55 (550)
5/8	15.88	63 to 77 (630 to 770)	65 (650)

6-3. Tools

6-3-1. Required tools

The service port diameter of packed valve of the outdoor unit in the air conditioner using R410A is changed to prevent mixing of other refrigerant. To reinforce the pressure-resisting strength, flare processing dimensions and opposite side dimension of flare nut (For $\varnothing 12.70$ copper pipe) of the refrigerant piping are lengthened.

The used refrigerating oil is changed, and mixing of oil may cause a trouble such as generation of sludge, clogging of capillary, etc. Accordingly, the tools to be used are classified into the following three types.

- (1) Tools exclusive for R410A (Those which cannot be used for conventional refrigerant (R22))
- (2) Tools exclusive for R410A, but can be also used for conventional refrigerant (R22)
- (3) Tools commonly used for R410A and for conventional refrigerant (R22)

The table below shows the tools exclusive for R410A and their interchangeability.

Tools exclusive for R410A (The following tools for R410A are required.)

Tools whose specifications are changed for R410A and their interchangeability

No.	Used tool	Usage	R410A air conditioner installation		Conventional air conditioner installation
			Existence of new equipment for R410A	Whether conventional equipment can be used	Whether new equipment can be used with conventional refrigerant
①	Flare tool	Pipe flaring	Yes	*(Note 1)	○
②	Copper pipe gauge for adjusting projection margin	Flaring by conventional flare tool	Yes	*(Note 1)	*(Note 1)
③	Torque wrench	Connection of flare nut	Yes	×	×
④	Gauge manifold	Evacuating, refrigerant charge, run check, etc.	Yes	×	×
⑤	Charge hose				
⑥	Vacuum pump adapter	Vacuum evacuating	Yes	×	○
⑦	Electronic balance for refrigerant charging	Refrigerant charge	Yes	×	○
⑧	Refrigerant cylinder	Refrigerant charge	Yes	×	×
⑨	Leakage detector	Gas leakage check	Yes	×	○
⑩	Charging cylinder	Refrigerant charge	(Note 2)	×	×

(Note 1) When flaring is carried out for R410A using the conventional flare tools, adjustment of projection margin is necessary. For this adjustment, a copper pipe gauge, etc. are necessary.

(Note 2) Charging cylinder for R410A is being currently developed.

General tools (Conventional tools can be used.)

In addition to the above exclusive tools, the following equipments which serve also for R22 are necessary as the general tools.

- | | | |
|--|------------------------------|---|
| (1) Vacuum pump
Use vacuum pump by attaching vacuum pump adapter. | (4) Reamer | (9) Hole core drill ($\varnothing 65$) |
| (2) Torque wrench | (5) Pipe bender | (10) Hexagon wrench
(Opposite side 4 mm) |
| (3) Pipe cutter | (6) Level vial | (11) Tape measure |
| | (7) Screwdriver (+, -) | (12) Metal saw |
| | (8) Spanner of Monkey wrench | |

Also prepare the following equipments for other installation method and run check.

- | | |
|-----------------|----------------------------------|
| (1) Clamp meter | (3) Insulation resistance tester |
| (2) Thermometer | (4) Electro-scope |

6-4. Recharging of Refrigerant

When it is necessary to recharge refrigerant, charge the specified amount of new refrigerant according to the following steps.

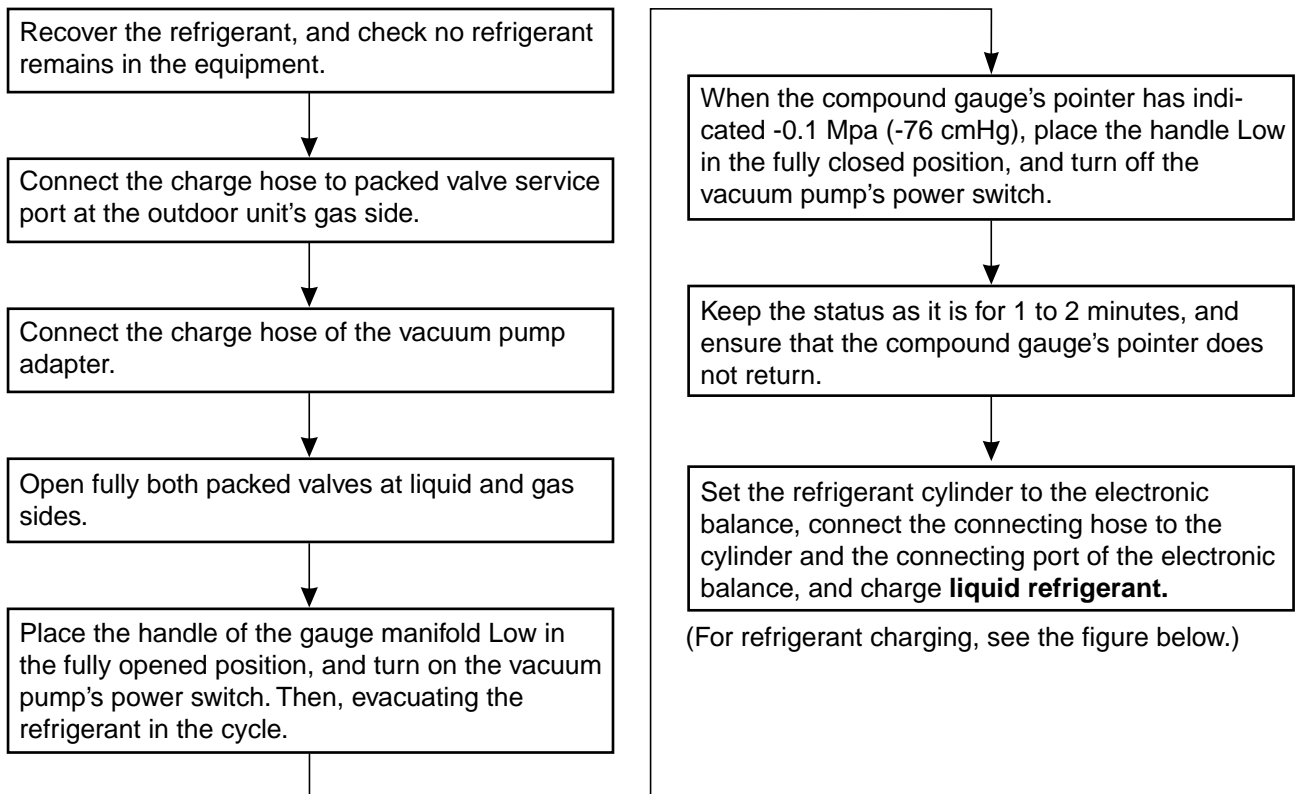

- ① Never charge refrigerant exceeding the specified amount.
- ② If the specified amount of refrigerant cannot be charged, charge refrigerant **bit by bit** in COOL mode.
- ③ Do not carry out additional charging.

When additional charging is carried out if refrigerant leaks, the refrigerant composition changes in the refrigeration cycle, that is characteristics of the air conditioner changes, refrigerant exceeding the specified amount is charged, and working pressure in the refrigeration cycle becomes abnormally high pressure, and may cause a rupture or personal injury.

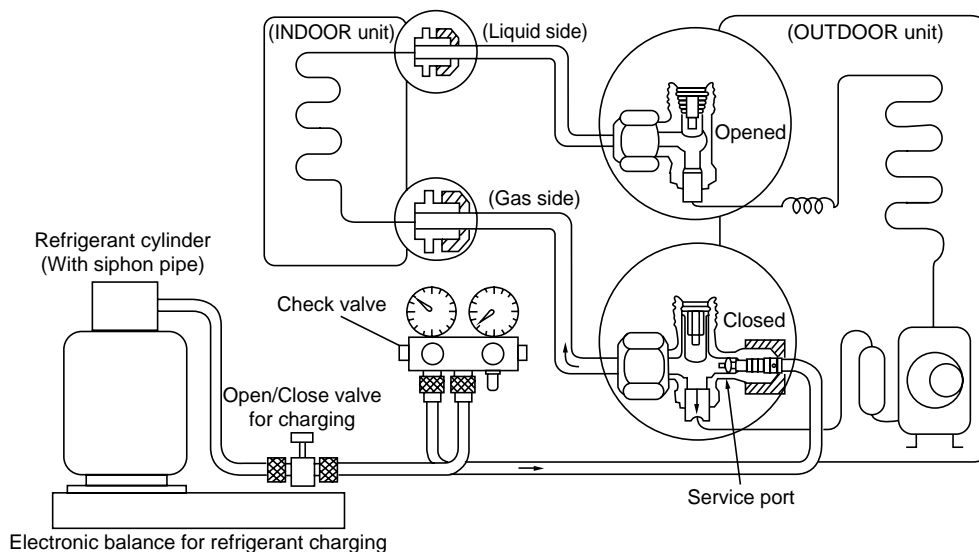
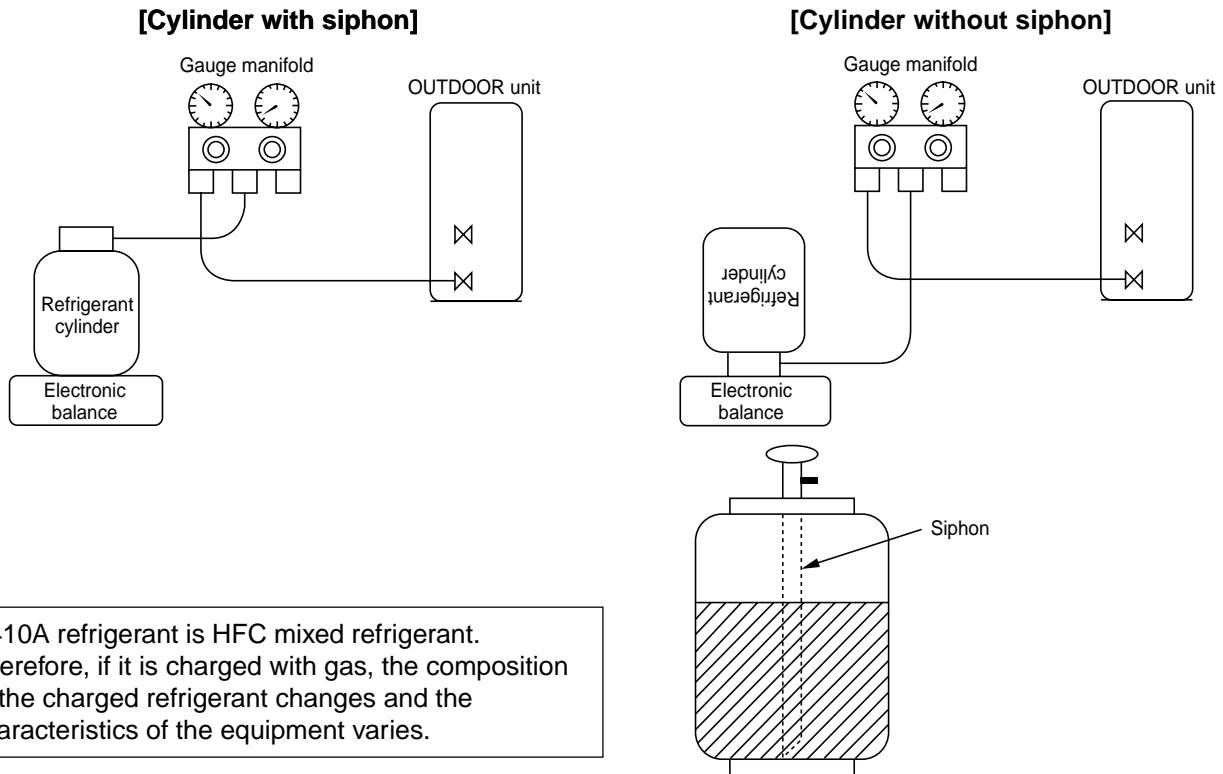

Fig. 6-4-1 Configuration of refrigerant charging

- ① Be sure to make setting so that **liquid** can be charged.
- ② When using a cylinder equipped with a siphon, liquid can be charged without turning it upside down.

It is necessary for charging refrigerant under condition of liquid because R410A is mixed type of refrigerant. Accordingly, when charging refrigerant from the refrigerant cylinder to the equipment, charge it turning the cylinder upside down if cylinder is not equipped with siphon.



R410A refrigerant is HFC mixed refrigerant. Therefore, if it is charged with gas, the composition of the charged refrigerant changes and the characteristics of the equipment varies.

Fig. 6-4-2

6-5. Brazing of Pipes

6-5-1. Materials for brazing

(1) Silver brazing filler

Silver brazing filler is an alloy mainly composed of silver and copper. It is used to join iron, copper or copper alloy, and is relatively expensive though it excels in solderability.

(2) Phosphor bronze brazing filler

Phosphor bronze brazing filler is generally used to join copper or copper alloy.

(3) Low temperature brazing filler

Low temperature brazing filler is generally called solder, and is an alloy of tin and lead. Since it is weak in adhesive strength, do not use it for refrigerant pipes.

- ① Phosphor bronze brazing filler tends to react with sulfur and produce a fragile compound water solution, which may cause a gas leakage. Therefore, use any other type of brazing filler at a hot spring resort, etc., and coat the surface with a paint.
- ② When performing brazing again at time of servicing, use the same type of brazing filler.

6-5-2. Flux

(1) Reason why flux is necessary

- By removing the oxide film and any foreign matter on the metal surface, it assists the flow of brazing filler.
- In the brazing process, it prevents the metal surface from being oxidized.
- By reducing the brazing filler's surface tension, the brazing filler adheres better to the treated metal.

(2) Characteristics required for flux

- Activated temperature of flux coincides with the brazing temperature.
- Due to a wide effective temperature range, flux is hard to carbonize.
- It is easy to remove slag after brazing.
- The corrosive action to the treated metal and brazing filler is minimum.
- It excels in coating performance and is harmless to the human body.

As the flux works in a complicated manner as described above, it is necessary to select an adequate type of flux according to the type and shape of treated metal, type of brazing filler and brazing method, etc.

(3) Types of flux

• Noncorrosive flux

Generally, it is a compound of borax and boric acid.

It is effective in case where the brazing temperature is higher than 800°C.

• Activated flux

Most of fluxes generally used for silver brazing are this type.

It features an increased oxide film removing capability due to the addition of compounds such as potassium fluoride, potassium chloride and sodium fluoride to the borax-boric acid compound.

(4) Piping materials for brazing and used brazing filler/flux

Piping material	Used brazing filler	Used flux
Copper - Copper	Phosphor copper	Do not use
Copper - Iron	Silver	Paste flux
Iron - Iron	Silver	Vapor flux

- ① Do not enter flux into the refrigeration cycle.
- ② When chlorine contained in the flux remains within the pipe, the lubricating oil deteriorates. Therefore, use a flux which does not contain chloring.
- ③ When adding water to the flux, use water which does not contain chlorine (e.g. distilled water or ion-exchange water).
- ④ Remove the flux after brazing.

6-5-3. Brazing

As brazing work requires sophisticated techniques, experiences based upon a theoretical knowledge, it must be performed by a person qualified.

In order to prevent the oxide film from occurring in the pipe interior during brazing, it is effective to proceed with brazing while letting dry Nitrogen gas (N₂) flow.

Never use gas other than Nitrogen gas.

(1) Brazing method to prevent oxidation

- ① Attach a reducing valve and a flow-meter to the Nitrogen gas cylinder.
- ② Use a copper pipe to direct the piping material, and attach a flow-meter to the cylinder.
- ③ Apply a seal into the clearance between the piping material and inserted copper pipe for Nitrogen in order to prevent backflow of the Nitrogen gas.
- ④ When the Nitrogen gas is flowing, be sure to keep the piping end open.
- ⑤ Adjust the flow rate of Nitrogen gas so that it is lower than 0.05 m³/Hr or 0.02 Mpa (0.2 kgf/cm²) by means of the reducing valve.
- ⑥ After performing the steps above, keep the Nitrogen gas flowing until the pipe cools down to a certain extent (temperature at which pipes are touchable with hands).
- ⑦ Remove the flux completely after brazing.

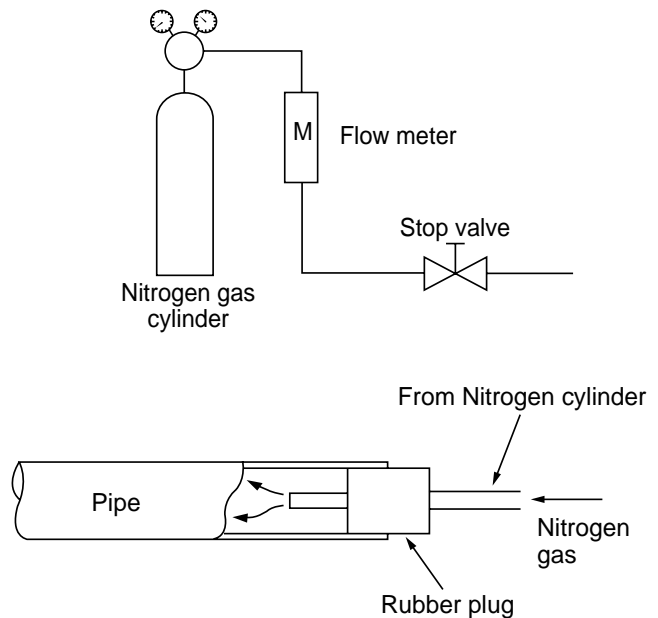
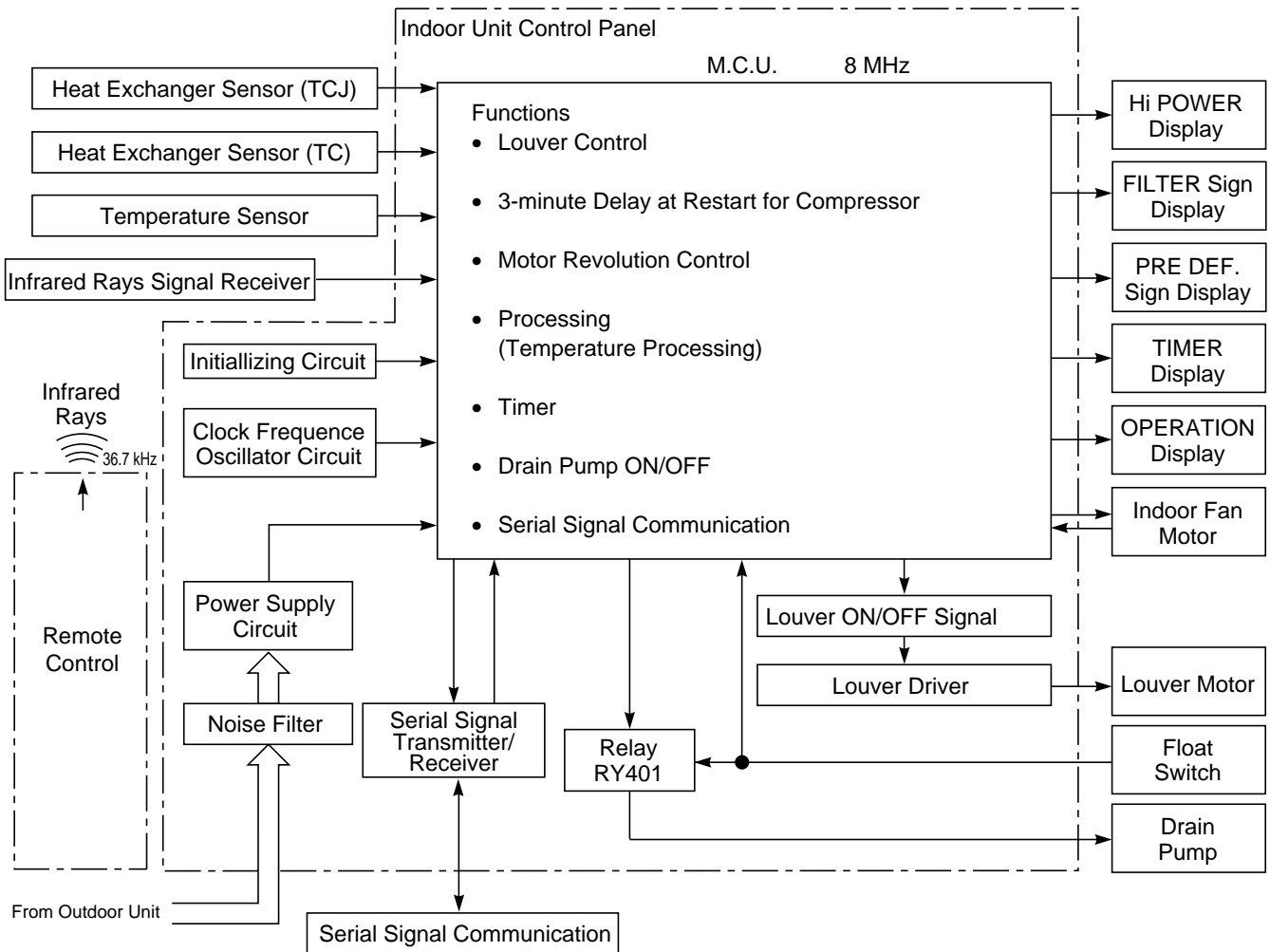
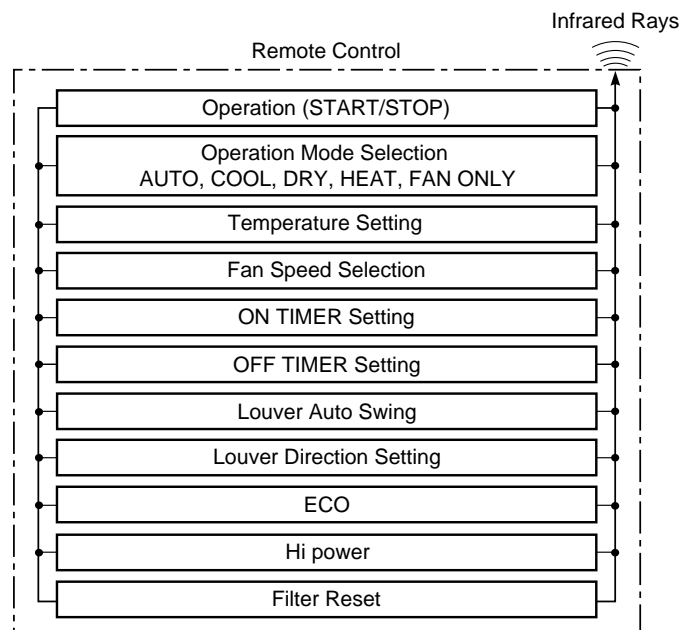

Fig. 6-5-1 Prevention of oxidation during brazing

7. CONTROL BLOCK DIAGRAM



REMOTE CONTROL



8. OPERATION DESCRIPTION

8-1. When power supply is reset

- (1) Distinction of outdoor units
When the power supply is reset, the outdoors are distinguished, and control is exchanged according to the distinguished result.
- (2) Setting of the indoor fan speed
Based on EEPROM data, rspeed of the indoor fan is selected.

Remarks: Air speed

8-2. Operation mode selection

- (1) Based on the operation mode selecting command from the remote control, the operation mode is selected.

Table 8-2-1

Remote control command	Outline of control
STOP	Air conditioner stops.
FAN	Fan operation
COOL	Cooling operation
DRY	Dry operation
HEAT	Heating operation
AUTO	Automatic operation

- (2) Automatic Operation
 - The air conditioner selects and operates in one of the operating modes of cooling, heating or fan only, depending on the room temperature.
 - If the AUTO mode is uncomfortable, you can select the desired conditions manually.

8-3. Air volume control

- (1) Operation with [HIGH (H)], [MED (M)], [LOW (L)], or [AUTO] mode is performed by the command from the remote control.
- (2) When [FAN] button is set to AUTO, the indoor fan motor operates as shown in Fig. 8-3-1, Fig. 8-3-2 and Table 8-3-1.

<COOL>

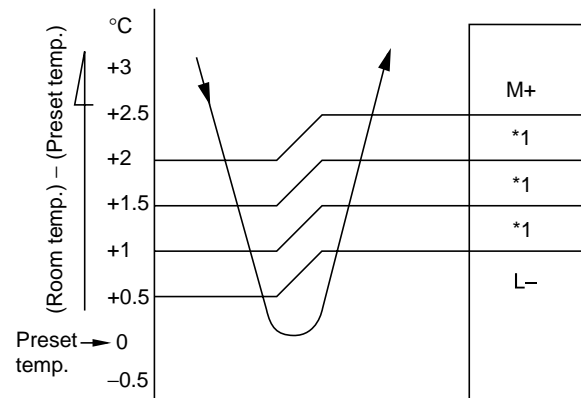

NOTE :

- *1: The values marked with *1 are calculated and controlled by the difference in motor speed between M+ and L-.

Fig. 8-3-1

Table 8-2-2

Room temperature in operation	Operating condition	
The set temperature +1°C or higher (in case that the room is hot)	Cooling operation	Performs the cooling operation at a temperature 1°C higher than the setting.
The set temperature -1°C to +1°C	Fan only operation	Performs the fan only operation (low speed) while monitoring the room temperature. When the room temperature changes, the air conditioner will select the cooling or heating mode.
The set temperature -1°C or lower (in case that the room is cold)	Heating operation	Performs the heating operation at a temperature 1°C lower than the setting.

<HEAT>

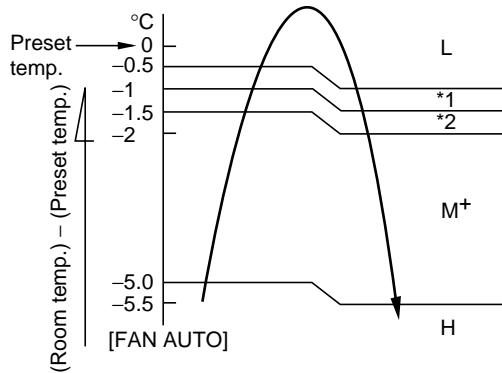

NOTE :

*1, *2 : The values marked with *1 and *2 are calculated and controlled by the difference in motor speed between M+ and L.

Fig. 8-3-2

Table 8-3-1

MODEL		RAV-SM562XT-E		RAV-SM802XT-E	
		Motor speed (rpm)	Air flow level (m ³ /h)	Motor speed (rpm)	Air flow level (m ³ /h)
Cooling and Fan only	HIGH	1060	800	1190	900
	MED	950	690	1010	750
	LOW	800	580	850	650
Heating	HIGH	1120	830	1300	980
	MED	970	730	1070	800
	LOW	820	600	860	650

$$LOW^+ = \frac{LOW+MED}{2}$$

$$MED^+ = \frac{MED+HIGH}{2}$$

8-4. Cool air discharge preventive control

In heating operation, the indoor heat exchanger restricts revolving speed of the fan motor to prevent a cold draft. The upper limit of the revolving speed is shown in Fig. 8-4-1 and Table 8-4-1.

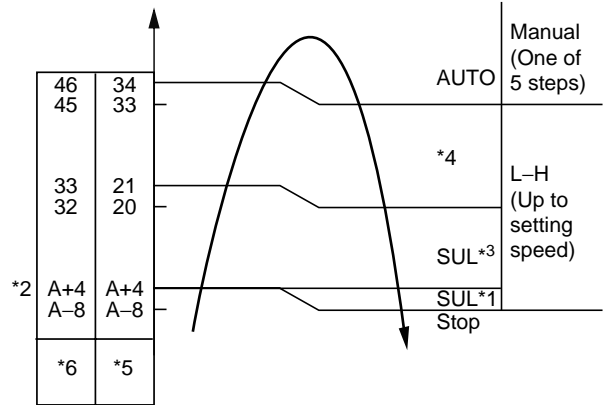

NOTES :

- *1: The fan stops for 2 minutes after thermostat-OFF.
- *2: A is 24°C when the preset temperature is 24°C or more and A is the preset temperature when it is under 24°C.
- *3: SUL means Super Ultra Low.
- *4: Calculated from difference in motor speed between SUL and HIGH.

Fig. 8-4-1 Cold draft preventing control

*5 and *6:

Table 8-4-1

Fan speed	*5 Starting period	*6 Stabilized period
AUTO	<ul style="list-style-type: none"> • Up until 12 minutes passed after starting the unit • From 12 to 25 minutes passed after starting the unit and room temperature is 3°C lower than preset temperature 	<ul style="list-style-type: none"> • From 12 to 25 minutes passed after starting the unit and room temperature is between preset temperature and 3°C lower than preset temperature • 25 minutes or more passed after starting the unit
Manual (L - H)	<ul style="list-style-type: none"> • Room temperature < Preset temperature -4°C 	<ul style="list-style-type: none"> • Room temperature ≥ Preset temperature -3.5°C

8-5. Freeze preventive control (Low temperature release)

The cooling operation (including Dry operation) is performed as follows based on the detected temperature of Tc sensor or Tcj sensor.

When [J] zone is detected for T1 minutes (Following figure), the commanded frequency is decreased from the real operation frequency. After then the commanded frequency changes every 2 minutes while operation is performed in [J] zone.

	T1
Normal	1 minute

In [K] zone, time counting is interrupted and the operation is held.

When [I] zone is detected, the timer is cleared and the operation returns to the normal operation.

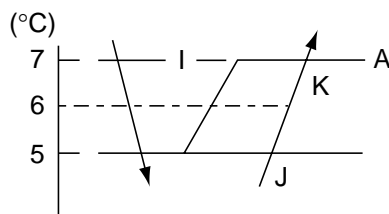

Fig. 8-5-1

In heating operation, the freeze-preventive control works if 4-way valve is not exchanged and the condition is satisfied.

Remarks:

Tcj : Indoor heat exchanger sensor temperature

8-6. High-temp release control

The heating operation is performed as follows based on the detected temperature of Tc sensor.

- When [M] zone is detected, the commanded frequency is decreased from the real operation frequency. After then the commanded frequency changes every 30 seconds while operation is performed in [M] zone.
- In [N] zone, the commanded frequency is held.
- When [L] zone is detected, the commanded frequency is returned to the original value by approx. 6Hz every 60 seconds.

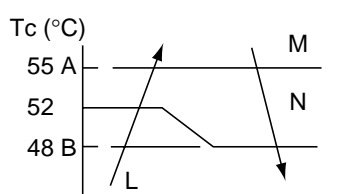

Fig. 8-6-1

8-7. Louver control

- (1) Vertical air flow louver
Position of vertical air flow louver is automatically controlled according to the operation mode. Besides, position of vertical air flow louver can be arbitrarily set by pressing [FIX] button. The louver position which is set by [FIX] button is stored in the microcomputer, and the louver is automatically set at the stored position for the next operation.
- (2) Swing
If [SWING] button is pressed when the indoor unit is in operation, the vertical air flow louver starts swinging. When [SWING] button is pressed, it stops swinging.

8-8. Filter sign display

- (1) The operation time of the indoor fan is calculated, the filter lamp (Orange) on the display part of the main unit goes on when the specified time (240H) has passed. When a wired remote controller is connected, the filter reset signal is sent to the remote controller, and also it is displayed on LCD of the wired remote control.
- (2) When the filter reset signal has been received from the wired remote control after [FILTER] lamp has gone on or when the filter check button (Temporary button) is pushed, time of the calculation timer is cleared. In this case, the measurement time is reset if the specified time has passed, and display on LCD and the display on the main unit disappear.

Remarks:

[FILTER] goes on

8-9. Auto Restart Function

The indoor unit is equipped with an automatic restarting function which allows the unit to restart operating with the set operating conditions in the event of power supply being accidentally shut down. The operation will resume without warning three minutes after power is restored. This function is not set to work when shipped from the factory. Therefore it is necessary to set it to work.

8-9-1. How to set auto restart function

To set the auto restart function, proceed as follows:
 The power supply to the unit must be on; the function will not set if the power is off.
 Push the [TEMPORARY] button located in the center of the front panel continuously for three seconds.
 The unit receives the signal and beeps three times.
 The unit then restarts operating automatically in the event of power supply being accidentally shut down.

When the unit is on standby (Not operating)

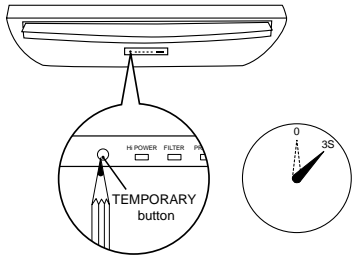
Operation	Motions
<p>Push [TEMPORARY] button for more than three seconds.</p> 	<p>The unit is on standby.</p> <p style="text-align: center;">↓</p> <p>The unit starts to operate. The green lamp is on.</p> <p style="text-align: center;">↓ After approx. three seconds,</p> <p>The unit beeps three times and continues to operate. The lamp changes from green to orange.</p> <p>If the unit is not required to operate at this time, push [TEMPORARY] button once more or use the remote control to turn it off.</p>

When the unit is in operation

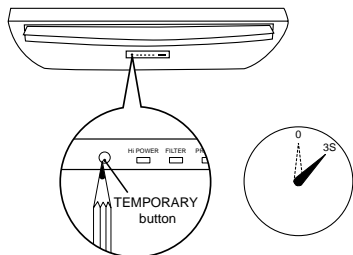
Operation	Motions
<p>Push [TEMPORARY] button for more than three seconds.</p> 	<p>The unit is in operation. The green lamp is on.</p> <p style="text-align: center;">↓</p> <p>The unit stops operating. The green lamp is turned off.</p> <p style="text-align: center;">↓ After approx. three seconds,</p> <p>The unit beeps three times.</p> <p>If the unit is required to operate at this time, push [TEMPORARY] button once more or use the remote control to turn it on.</p>

- While this function is being set, if the unit is in operation, the orange lamp is on.
- This function can not be set if the timer operation has been selected.
- When the unit is turned on by this function, the louver will not swing even though it was swinging automatically before shutting down.
- While the filter check lamp is on, the TEMPORARY button has the function of filter reset button.

8-9-2. How to cancel auto restart function

To cancel auto restart function, proceed as follows:
Repeat the setting procedure: the unit receives the signal and beeps three times.

The unit will be required to be turned on with the remote control after the main power supply is turned off.

When the unit is on standby (Not operating)

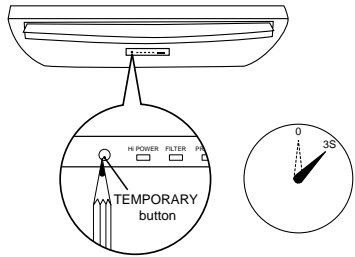
Operation	Motions
<p>Push [TEMPORARY] button for more than three seconds.</p> 	<p>The unit is on standby.</p> <p style="text-align: center;">↓</p> <p>The unit starts to operate. The orange lamp is on.</p> <p style="text-align: center;">↓ After approx. three seconds,</p> <p>The unit beeps three times and continues to operate. The lamp changes from orange to green.</p> <p>If the unit is not required to operate at this time, push [TEMPORARY] button once more or use the remote control to turn it off.</p>

When the unit is in operation

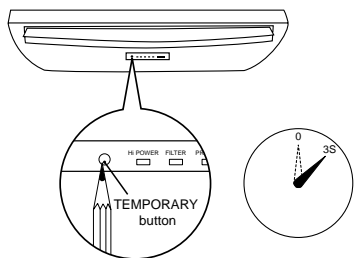
Operation	Motions
<p>Push [TEMPORARY] button for more than three seconds.</p> 	<p>The unit is in operation. The orange lamp is on.</p> <p style="text-align: center;">↓</p> <p>The unit stops operating. The orange lamp is turned off.</p> <p style="text-align: center;">↓ After approx. three seconds,</p> <p>The unit beeps three times.</p> <p>If the unit is required to operate at this time, push [TEMPORARY] button once more or use the remote control to turn it on.</p>

- While this function is being set, if the unit is in operation, the orange lamp is on.

8-9-3. Power failure during timer operation

When the unit is in Timer operation, if it is turned off because of power failure, the timer operation is cancelled. Therefore, set the timer operation again.

8-10. Filter Check Lamp

When the elapsed time reaches 1000 hours, the filter check lamp indicates. After cleaning the filters, turn off the filter check lamp.

8-10-1. How to turn off filter check lamp

- (1) Press [FILTER] button on the remote control.
- (2) Push [TEMPORARY] button on the indoor unit.

Note:

If [TEMPORARY] button is pushed while the filter check lamp is not indicating, the indoor unit will start the Automatic Operation.

9. TROUBLESHOOTING

9-1. Summary of Troubleshooting

9-1-1. Before troubleshooting

- (1) Required tools/instruments
 - ⊕ and ⊖ screwdrivers, spanners, radio cutting pliers, nippers, etc.
 - Tester, thermometer, pressure gauge, etc.
- (2) Confirmation points before check
 - ① The following operations are normal.
 - a) Compressor does not operate.
 - Is not 3-minutes delay (3 minutes after compressor OFF)?
 - Does not thermostat turn off?
 - Does not timer operate during fan operation?
 - Is not outside high-temperature operation controlled in heating operation?
 - b) Indoor fan does not rotate.
 - Does not cool air discharge preventive control work in heating operation?
 - c) Outdoor fan does not rotate or air volume changes.
 - Does not high-temperature release operation control work in heating operation?
 - Does not outside low-temperature operation control work in cooling operation?
 - Is not defrost operation performed?
 - d) ON/OFF operation cannot be performed from remote control.
 - Is not forced operation performed?
 - Is not the control operation performed from outside/remote side?
 - ② Did you return the cabling to the initial positions?
 - ③ Are connecting cables between indoor unit and receiving unit correct?

9-1-2. Troubleshooting procedure

When a trouble occurred, check the parts along with the following procedure.

Trouble → Confirmation of check code by service mode

→ Check defective position and parts.

NOTE :

For cause of a trouble, power conditions or malfunction/erroneous diagnosis of microcomputer due to outer noise is considered except the items to be checked. If there is any noise source, change the cables of the signal line to shield cables.

9-1-3. Outline of Judgment

A primary judgment to detect cause of error exists on the indoor unit or outdoor unit is performed in the following procedure.

<Judgment by flashing display on the indoor unit display part>

The indoor unit monitors operating status of the air conditioner, and if a protective circuit works, contents of the self-diagnosis are displayed with a block restricted to the following cases on the indoor unit display part (Sensor).

Table 9-1-1

Remote control code	Block display	Contents of self-diagnosis	Check code
—	Operation lamp display flashes. (1Hz)	Power failure (In power ON)	—
00	Operation lamp display flashes. (5Hz)	Indoor P.C. board	0b to 0F, 11, 12, b5, b6
01	Operation/timer lamp displays flash. (5Hz)	Inter-unit cables/transmission system	04
02	Operation/defrost lamp displays flash. (5Hz)	Outdoor P.C. board	14 to 19, 1A, 1C
03	Operation/timer/defrost lamp displays flash. (5Hz)	Cycle system, etc.	1d, 1E, 1F, 21
—	—	—	1b, 8b

9-2. Self-Diagnosis by Remote Control (Check Code)

- (1) If the lamps are indicated as shown 00 to 03 in Table 9-1-1, exchanger the self-diagnosis by the remote control.
- (2) When the remote control is set to the service mode, the indoor controller diagnoses the operation condition and indicate the information of the self-diagnosis on the display of the remote control with the check codes. If a fault is detected, all lamps on the indoor unit will blink at 5 Hz and it will beep for 10 seconds (Pi, Pi, Pi...). The timer lamp usually blinks (5 Hz) during the self-diagnosis.

9-2-1. How to use remote control in service mode

(1) Press [CHECK] button with a tip of pencil to set the remote control to the service mode.

- “00” is indicated on the display of the remote control.
- The timer lamp on the indoor unit blinks continuously. (5 times per 1 sec.)

(2) Press [TIMER ▲] button.
If there is no fault with a code, the indoor unit will beep once (Pi) and the display of the remote control will change as follows:

→ 00 → 01 → 02 ... 1d → 1E → 22

- Check the unit with all 35 check codes (00 to 22), as shown in Table 9-2-1.
- Press [TIMER ▼] button to change the check code backwards.

If there is a fault, the indoor unit will beep for 10 seconds (Pi, Pi, Pi...).
Note the check code on the display of the remote control.

- 2-digits alphanumeric will be indicated on the display.
- All lamps on the indoor unit will blink. (5 times per 1 sec.)

(3) Press [CLR] button. After service finish for clear service code in memory.

- “7F” is indicated on the display of the remote control.

(4) Press [START/STOP] button to release the service mode.

- The display of the remote control returns to as it was before service mode was engaged.

• Alphanumeric characters are used for the check code.

S is 5. *b* is 6.
A is A. *b* is B.
C is C. *d* is D.

Table 9-2-1

Operation of diagnostic function						Judgement and action
Check code	Block	Check code	Symptom	Unit status	Condition	
00	Indoor P.C. board	0C	The indoor thermo sensor (TA) is defective. Disconnection or short-circuit	Operation continues.	The lamp on the indoor unit blinks when error is defected.	1. Check the indoor thermo sensor (TA). 2. Check the indoor P.C. board.
		0d	The indoor heat exchanger sensor (TC) is defective. Disconnection or short-circuit	Operation continues.	The lamp on the indoor unit blinks when error is defected.	1. Check the indoor heat exchanger sensor (TC). 2. Check the indoor P.C. board.
		11	The indoor fan motor or its circuit is defective.	All off	The lamp on the indoor unit blinks when error is defected.	1. Check the connector circuit of the indoor fan motor (CN10). 2. Check the indoor fan motor. 3. Check the indoor P.C. board.
		12	The part other than the above parts on the indoor P.C. board is defective. EEPROM access error	Operation continues.	The lamp on the indoor unit blinks when error is defected.	1. Check the indoor P.C. board. (EEPROM and peripheral circuits)
		21	IOL operation	All off	The lamp on the indoor unit blinks when error is defected.	Overload operation of refrigerating cycle
	The block is unidentifiable	13	The variation of TC, 5 minutes after starting the compressor, is 2K or less.	Operation continues.	The lamp on the indoor unit blinks when error is defected.	1. Check whether or not the TC sensor comes off. 2. Check whether or not it is possible to operate the compressor and the outdoor fan motor. 3. Check gas leak.
01	Cable connection	04	The serial signals can not be transmitted and received between indoor and outdoor units. • The crossover wire is connected wrongly. • The serial signal transmitting circuit on the outdoor P.C. board is defective. • The serial signal receiving circuit on the indoor P.C. board is defective.	Operation continues.	The lamp on the indoor unit blinks when error is defected.	1. In the case of the outdoor unit not operating at all; • Check the crossover cable and connect it properly. • Check the outdoor P.C. board. 2. In the case of the outdoor unit operating normally; • Check whether or not both of serial LED (Green) and serial LED (Orange) is blinking. If the serial LED (Green) is not blinking, check the outdoor P.C. board. If the serial LED (Orange) is not blinking, check the indoor P.C. board.
		05	The operation command signals are not transmitted from the indoor unit to the outdoor unit.	Operation continues.	The lamp on the indoor unit blinks when error is defected. And it returns to the normal condition when recovering from errors.	If the operation command signals continue to be transmitted between ② and ③ of the indoor terminal block, replace the outdoor P.C. board.
02	Outdoor P.C. board	18	The outdoor thermo sensor (TE) is defective. Disconnection or short-circuit	All off	The lamp on the indoor unit blinks when error is defected.	1. Check the outdoor thermo sensor (TE). 2. Check the outdoor P.C. board.
		19	The outdoor heat exchanger (TD) sensor is defective. Disconnection or short-circuit	All off	The lamp on the indoor unit blinks when error is defected.	1. Check the outdoor heat exchanger sensor (TD). 2. Check the outdoor P.C. board.
03	Other parts (including compressor)	07	The reply serial signal has been transmitted when starting the unit, but stops being transmitted shortly after. 1. Compressor thermo operation • Gas shortage • Gas leak 2. Instantaneous power failure	Operation continues.	The lamp on the indoor unit blinks when error is defected. And it returns to the normal condition when recovering from errors.	1. Repeatedly turn the indoor unit on and off with the interval of approx. 10 to 40 minutes. (The check code is not indicated during operation.) And supply gas. (Check gas leak.) 2. The indoor unit operates normally during the check. If the reply serial signal continues to be transmitted between ② and ③ of the indoor terminal block, replace the outdoor P.C. board. If the signal stops between them, replace the indoor P.C. board.
		1E	The discharge temperature is over 120°C.	All off	The lamp on the indoor unit blinks when error is defected.	1. Check the heat exchanger sensor (TD). 2. Gas purging
		20	The IOL operation is defective.	All off	The lamp on the indoor unit blinks when error is detected.	When turning on the unit, the normal phase (RST) is detected but T-R waveform has not been detected for 120 seconds or more.

Table 9-2-2

Operation of diagnostic function					Judgement and action
Block	Check code	Symptom	Unit status	Condition	
[MODE] [TIMER] lamp 5Hz flash	04	The serial signal is not output from outdoor unit to indoor unit. • Miscabling of inter-unit cables • Defective serial sending circuit on outdoor P.C. board • Defective serial receiving circuit on outdoor P.C. board • Compressor case thermo operation	Operation continues.	Displayed when error is detected	<ol style="list-style-type: none"> Outdoor unit does not completely operate. • Inter-unit cable check, correction of miscabling • Outdoor P.C. board check, P.C. board cables check • Compressor case thermo check In normal operation When outdoor sending serial LED (Green) flashes, the receiving serial LED (Orange) also flashes. : Indoor P.C. board (Main P.C. board) check When the receiving serial LED (Orange) does not flash: Outdoor P.C. board check
	97	BUS communication circuit error * BUS communication was interrupted over the specified time.	Operation continues (According to remote control of indoor unit)	Displayed when error is detected	
	08	Error in 4-way valve system • Indoor heat exchanger temperature rise after start of cooling operation. • Indoor heat exchanger temperature fall after start of heating operation.	Operation continues.	Displayed when error is detected	<ol style="list-style-type: none"> Check 4-way valve. Check 2-way valve and non-return valve. Check indoor heat exchanger sensor (TC). Check indoor P.C. board (Main P.C. board).
	09 *	Error in other cycles • Indoor heat exchanger temp (TC) does not vary after start of cooling/ heating operation.	Operation continues.	Displayed when error is detected	
[MODE] lamp 5Hz flash	0C	Coming-off, disconnection or short of indoor temp sensor (TA)	Operation continues.	Displayed when error is detected	<ol style="list-style-type: none"> Check indoor temp sensor (TA). Check indoor P.C. board (Main P.C. board).
	0d	Coming-off, disconnection or short of indoor temp sensor (TC)	Operation continues.	Displayed when error is detected	
	0F	Coming-off, disconnection or short of indoor temp sensor (TCJ)	Operation continues.	Displayed when error is detected	
[MODE] lamp 5Hz flash	11	Error in indoor fan system Revolutions frequency error of fan	All stop	Displayed when error is detected	<ol style="list-style-type: none"> Check indoor fan motor connector circuit (CN210). Check indoor fan. Check indoor P.C. board (Main P.C. board).
	12	Error in indoor unit or other positions 1. EEPROM access error	Operation continues.	Displayed when error is detected	
	b5	Outside error input Detected by input voltage level from outside devices	Operation continues.	Displayed when error is detected	
	b6	Outside interlock input Detected by input voltage level from outside devices	All stop	Displayed when error is detected	

*: No display in the setting at shipment

Table 9-2-3



Operation of diagnostic function				Judgement and action
Check code	Symptom	Unit status	Condition	
14	Inverter over-current protective circuit operates. (For a short time)	All stop	Displayed when error is detected	1. Inverter immediately stops even if restarted. • Compressor rare short 2. Check IPDU. • Cabling error
17	Error on current detection circuit • Current value is high at AC side even while compressor stops. • Phase of power supply is missed.	All stop	Displayed when error is detected	1. Compressor immediately stops even if restarted. : Check IPDU. 2. Phase-missing operation of power supply • Check power voltage of R, S, T.
18	Coming-off, disconnection or short of outdoor temp sensor	All stop	Displayed when error is detected	1. Check outdoor temp sensor (TE, TS). 2. Check CDB.
19	Coming-off, disconnection or short of outdoor temp sensor	All stop	Displayed when error is detected	1. Check outdoor temp sensor (TD). 2. Check CDB.
1E	Compressor drive output error • Tin thermistor temp, Tin error (IPDU heat sink temp. is high.) • Communication error between IPDU • Connector coming-off between CDB and IPDU	All stop	Displayed when error is detected	1. Abnormal overload operation of refrigerating cycle 2. Loosening of screws and contact error of IPDU and heat sink 3. Cooling error of heat sink 4. Check cabling of CDB and IPDU.
1d	Compressor does not rotate. (Over-current protective circuit works when constant time passed after activation of compressor.)	All stop	Displayed when error is detected	1. Compressor error (Compressor lock, etc.) : Replace compressor. 2. Cabling trouble of compressor (Phase missing)
1E	Discharge temp error • Discharge temp over specified value was detected.	All stop	Displayed when error is detected	1. Check refrigerating cycle. (Gas leak) 2. Error of electron control valve 3. Check pipe sensor (TD).
1F	Compressor breakdown • Operation frequency lowered and stops though operation had started.	All stop	Displayed when error is detected	1. Check power voltage. (AC200V±20V) 2. Overload operation of refrigerating cycle 3. Check current detection circuit at AC side.
21	High-voltage protection error by TE sensor • TE temp over specified value was detected.	All stop	Displayed when error is detected	1. Overload operation of refrigerating cycle 2. Check outdoor temp sensor (TE).
1A	DC outdoor fan motor error • IDC operation or lock was detected by DC outdoor fan driving.	All stop	Displayed when error is detected	1. Position detection error 2. Over-current protection circuit operation of outdoor fan drive unit • Check CDB. • Refer to Judgment of outdoor fan.
1B	Error on IPDU position detection circuit	All stop	Displayed when error is detected	1. Position detection circuit operates even if driving by removing 3P connector of compressor. • Replace IPDU.
1b	Coming-off, disconnection or short of outdoor temp sensor	Operation continues.	Displayed when error is detected	1. Check outdoor temp sensor (TO). 2. Check P.C. board.

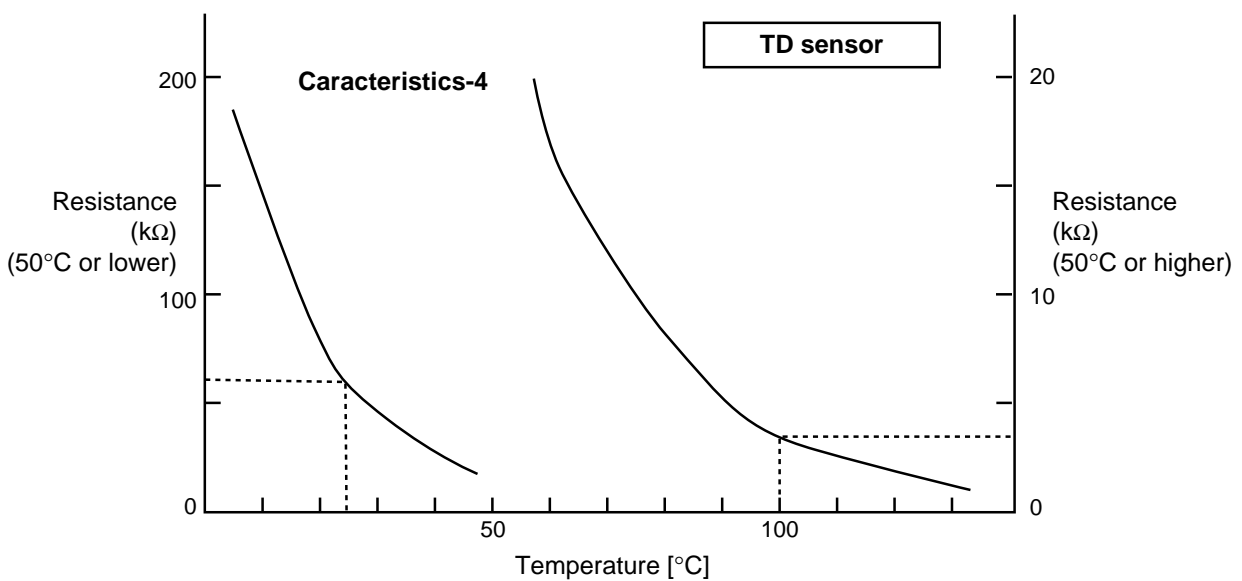
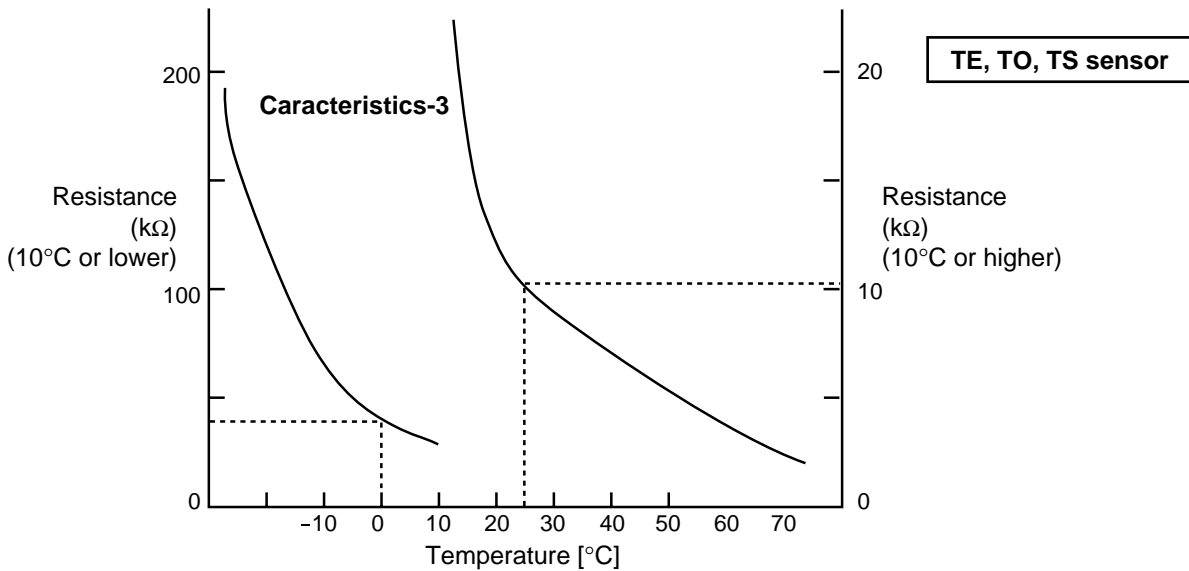
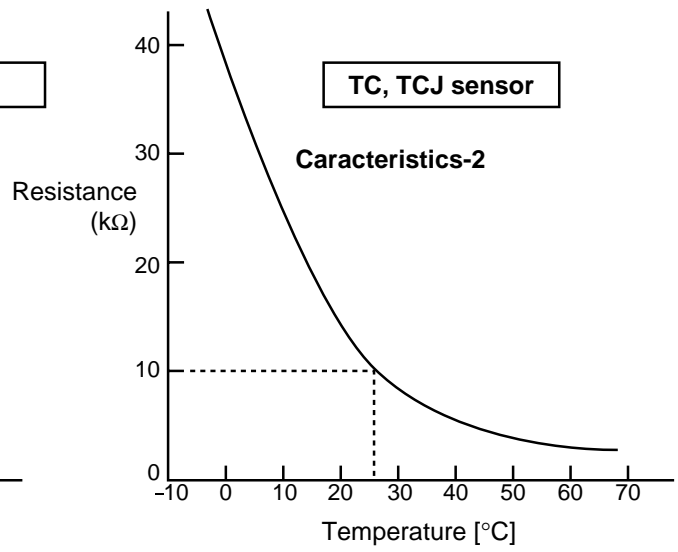
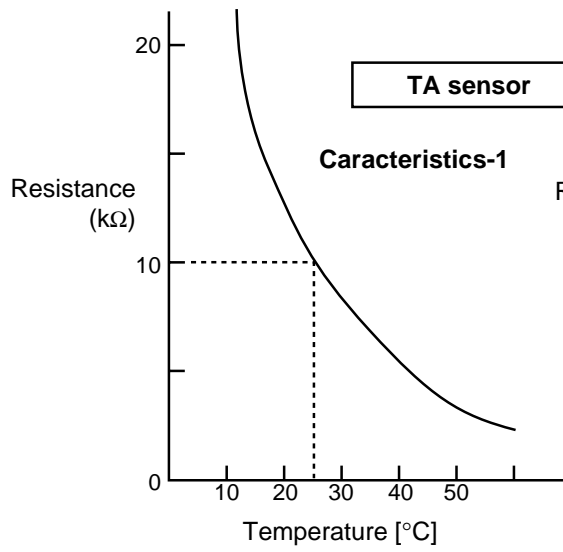



Relational graph of temperature sensor resistance value and temperature

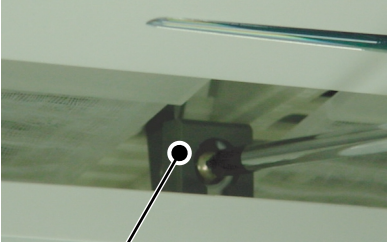
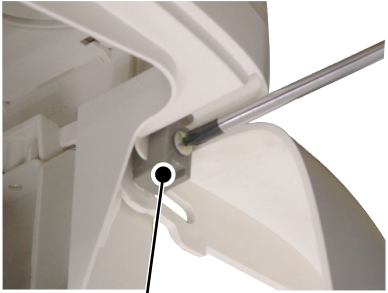

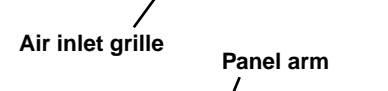
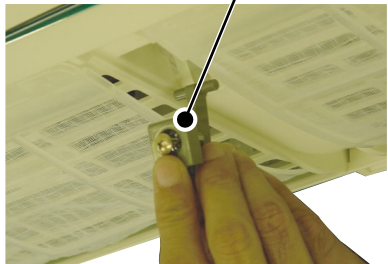
10. DETACHMENTS

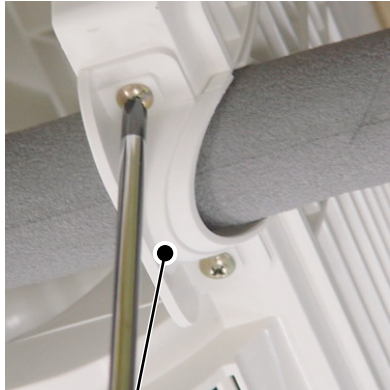
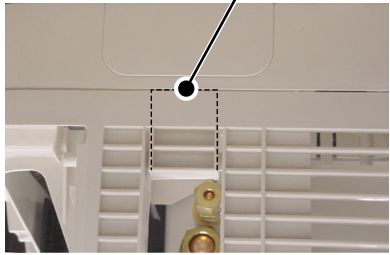
10-1. Indoor Unit

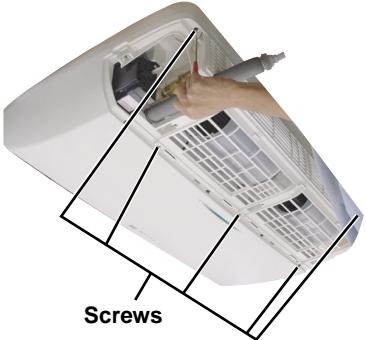
No.	Part name	Procedures	Remarks
①	Air Inlet grille	<p><How to remove the Air inlet grille></p> <ol style="list-style-type: none"> 1) Stop the operation of the Air conditioner and turn off its main power supply. 2) Open the Air inlet grille with both hands. 3) Unfasten 3 screws (about two to three rounds) for fixing the Panel arms. 4) Move the Air inlet grille toward. 5) Remove the Grille stopper from the axis of the Front panel. After that, remove the Air inlet grille. 6) Remove the Panel arms from the Front panel. <p><How to install the Air inlet grille></p> <ol style="list-style-type: none"> 1) Insert three Panel arms on the Air inlet grille and fix each securely by screws. 2) Set the Air inlet grille arm to the axis of the Front panel. 3) Insert the Grille stopper to the correct position and fix it securely with screws. 4) Push the Air inlet grille to the correct position. 	 <p style="text-align: center;">Air inlet grille</p>  <p style="text-align: center;">Panel arm</p>  <p style="text-align: center;">Grille stopper</p>  <p style="text-align: center;">Air inlet grille</p>  <p style="text-align: center;">Panel arm</p>  <p style="text-align: center;">Air inlet grille</p>

No.	Part name	Procedures	Remarks
②	Front panel	<p><How to remove the Front panel></p> <p>1) Remove the Air inlet grille. (①)</p> <p>2) In case of the Drain hose is installed through the Front panel. : Remove the Drain band from the Front panel. : Cut away the Opening base for piping from Front panel and keep parts.</p> <p>3) Open 3 Cap screws and remove the screws.</p> <p>4) Remove 5 screws fixing the Front panel.</p> <p>5) Remove the hooks of the Panel LED nearly side from the Drain pan.</p> <p>(Continue)</p>	 <p>Drain band Drain panel</p>  <p>Cap screws</p>  <p>Front Panel</p>  <p>Screws</p> 

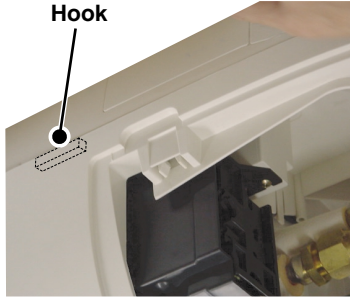
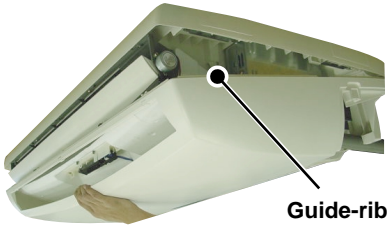
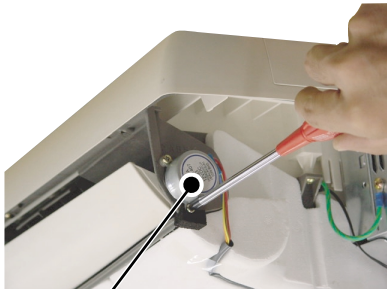
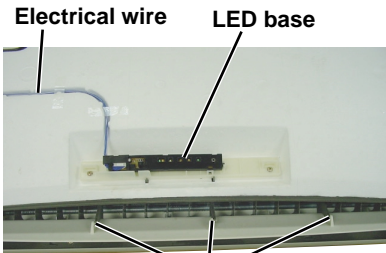
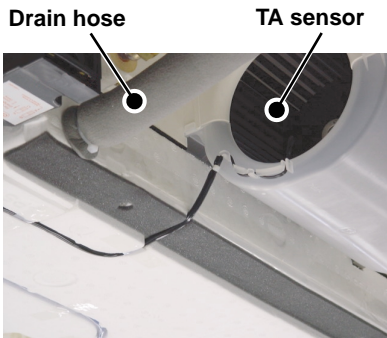
No.	Part name	Procedures	Remarks
②	Front panel	<p>6) Remove both side hooks and remove the Front panel by turn to air inlet part direction.</p> <p><How to install the Front panel></p> <p>1) In case of the Drain hose installation through the Front panel, install the opening base for piping in the Back body by a screw (M4 x 12). Prepare it by yourself.</p> <p>2) Fit the Front panel in the Drain pan. Then fix it in the Drain pan with 2 hooks in the center of the air outlet.</p> <p>3) Fix 5 hooks around the Front panel with conformation the Guide-rib is inserting into the Back body.</p> <p>4) Fix 8 screws and close 3 Cap screws.</p> <p>5) Install the Drain band into the Front panel.</p> <p>6) Check the gap between the Front panel and the Back body.</p>	 <p>Hook</p>  <p>Guide-rib</p>
③	Drain pan assembly	<p><How to remove the Drain pan></p> <p>1) Remove the Air inlet grille and the Front panel. (①, ②)</p> <p>2) Remove the Louver motor from the Drain pan.</p> <p>3) Remove the shaft of Horizontal louver.</p> <p>4) Remove the LED base and Electrical wire.</p> <p>5) Remove the TA sensor wire.</p> <p>6) Remove the Drain hose.</p>	 <p>Louver motor</p>  <p>Electrical wire LED base</p> <p>Shaft of Horizontal louver</p>  <p>Drain hose TA sensor</p>

(Continue)

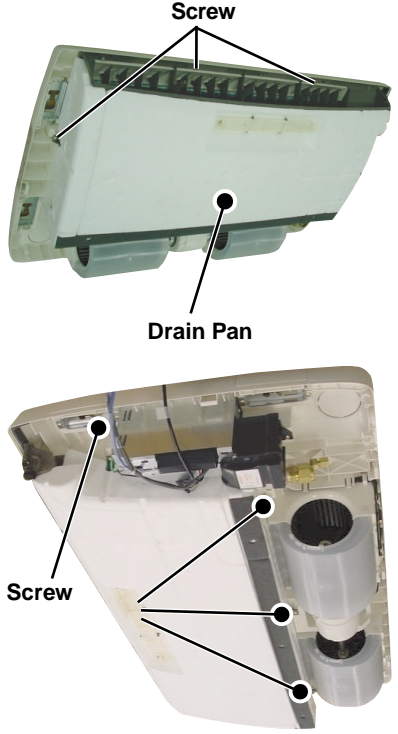
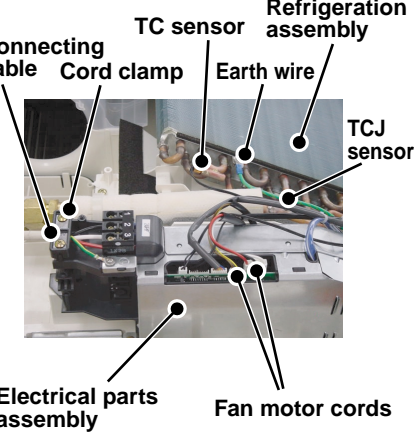
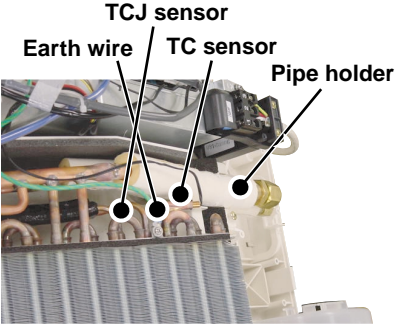
No.	Part name	Procedures	Remarks
③	Drain pan assembly	7) Remove 7 screws and remove the Drain pan assembly.	 <p>Screw</p> <p>Drain Pan</p> <p>Screw</p>
④	Electrical parts assembly	<p><How to remove the Electrical parts assembly></p> <ol style="list-style-type: none"> 1) Remove the Air inlet grille, the Front panel and the Drain pan assembly. (①, ②, ③) 2) Remove the Terminal cover. 3) Unfasten the screw of Cord clamp and disconnect the connecting cable. 4) Remove the Connector cover and disconnect the Fan motor cords. 5) Remove the TC sensor, TCJ sensor and earth wire from Refrigeration assembly. 6) Remove the Electrical parts assembly. <p>NOTE : When install the electrical parts assembly, fix the screw after the Back body is fixed.</p>	 <p>Connecting cable</p> <p>Cord clamp</p> <p>Earth wire</p> <p>TC sensor</p> <p>Refrigeration assembly</p> <p>TCJ sensor</p> <p>Electrical parts assembly</p> <p>Fan motor cords</p>
⑤	Refrigeration assembly	<p><How to remove the Refrigeration assembly></p> <ol style="list-style-type: none"> 1) Remove the Air inlet grille, the Front panel and the Drain pan assembly. (①, ②, ③) 2) Stop the gas at the Outdoor unit. 3) Remove 2 pipes from the Refrigeration assembly. 4) Remove the TC sensor and TCJ sensor from holder. 5) Remove the pipe holder. 6) Remove the earth wire. 	 <p>TCJ sensor</p> <p>Earth wire</p> <p>TC sensor</p> <p>Pipe holder</p>

(Continue)

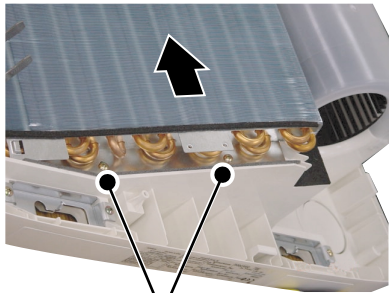
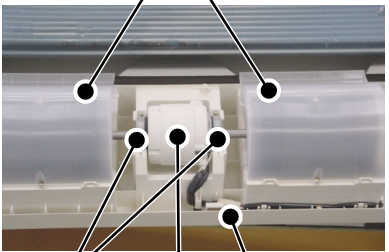
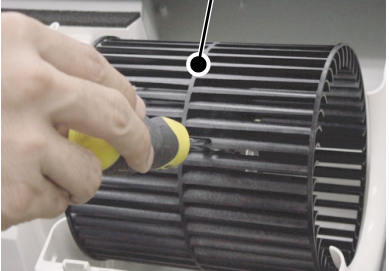
No.	Part name	Procedures	Remarks
⑤	Refrigeration assembly	7) Remove 2 screws and remove the refrigeration assembly with pushing it to right hand.	 <p>2 Screws</p>
⑥	Multiblade fan and Fan motor	<p><How to remove the Multiblade fan and Fan motor></p> <ol style="list-style-type: none"> 1) Remove the Air inlet grille and the Front panel. (①, ②) 2) Disconnect 2 connectors. 3) Remove the Fan covers. 4) Remove the Motor band with holding the Fan motor and then remove the Fan motor with the Multi-blade fans. <ol style="list-style-type: none"> 5) Unfasten the Set-screw and remove the Multi-blade fans. 	 <p>Fan cover</p> <p>Motor band Motor 2 Connectors</p>  <p>Multi-blade fan</p>

11. EXPLODED VIEWS AND PARTS LIST

11-1. Indoor Unit (E-Parts Assy)

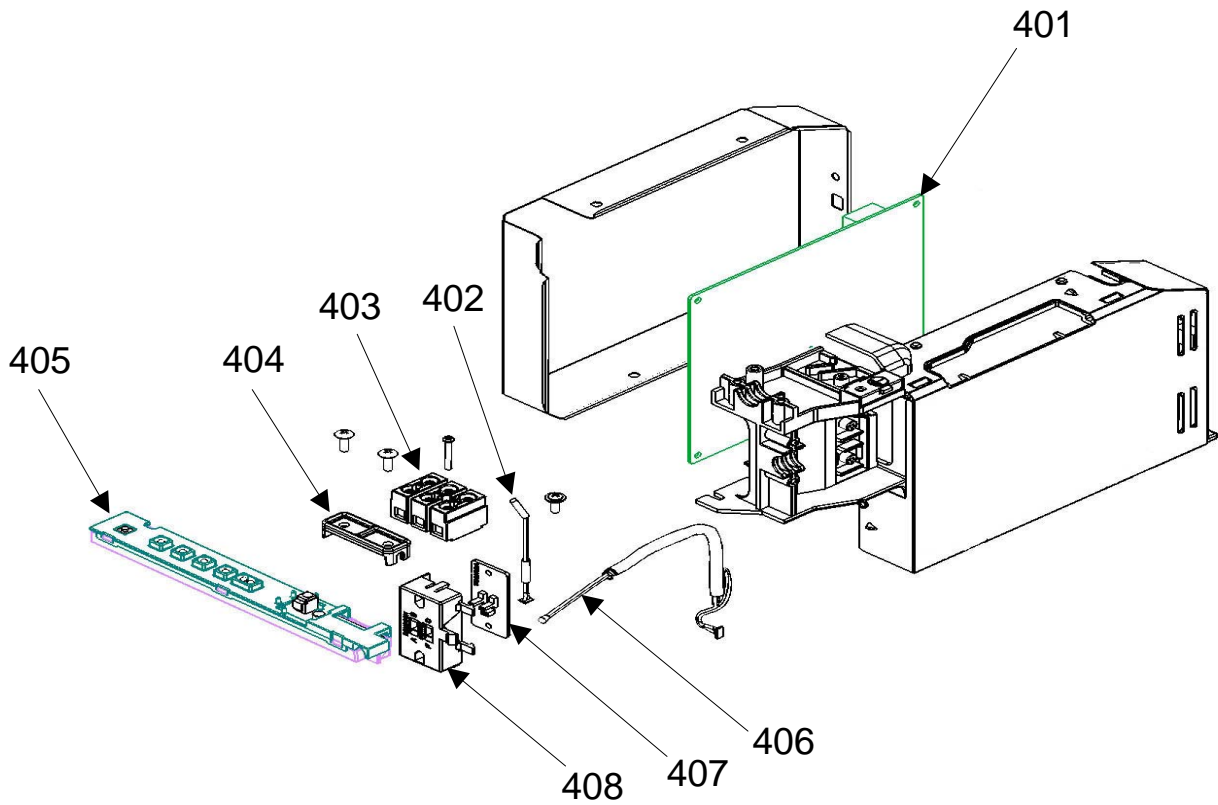

Location No.	Part No.	Description
401	43T69564	PC BOARD (RAV-SM802XT-E)
401	43T69565	PC BOARD (RAV-SM562XT-E)
402	43T50004	SENSOR; HEAT EXCHANGER
403	43T60002	TERMINAL BLOCK; 3P
404	43T62003	CORD CLAMP
405	43T69315	DISPLAY UNIT

Location No.	Part No.	Description
406	43T50302	TEMPERATURE SENSOR
407	43T69564	PC BOARD (RAV-SM562XT-E)
407	43T69565	PC BOARD (RAV-SM802XT-E)
408	43T08349	SWITCH COVER

11-2. Indoor Unit

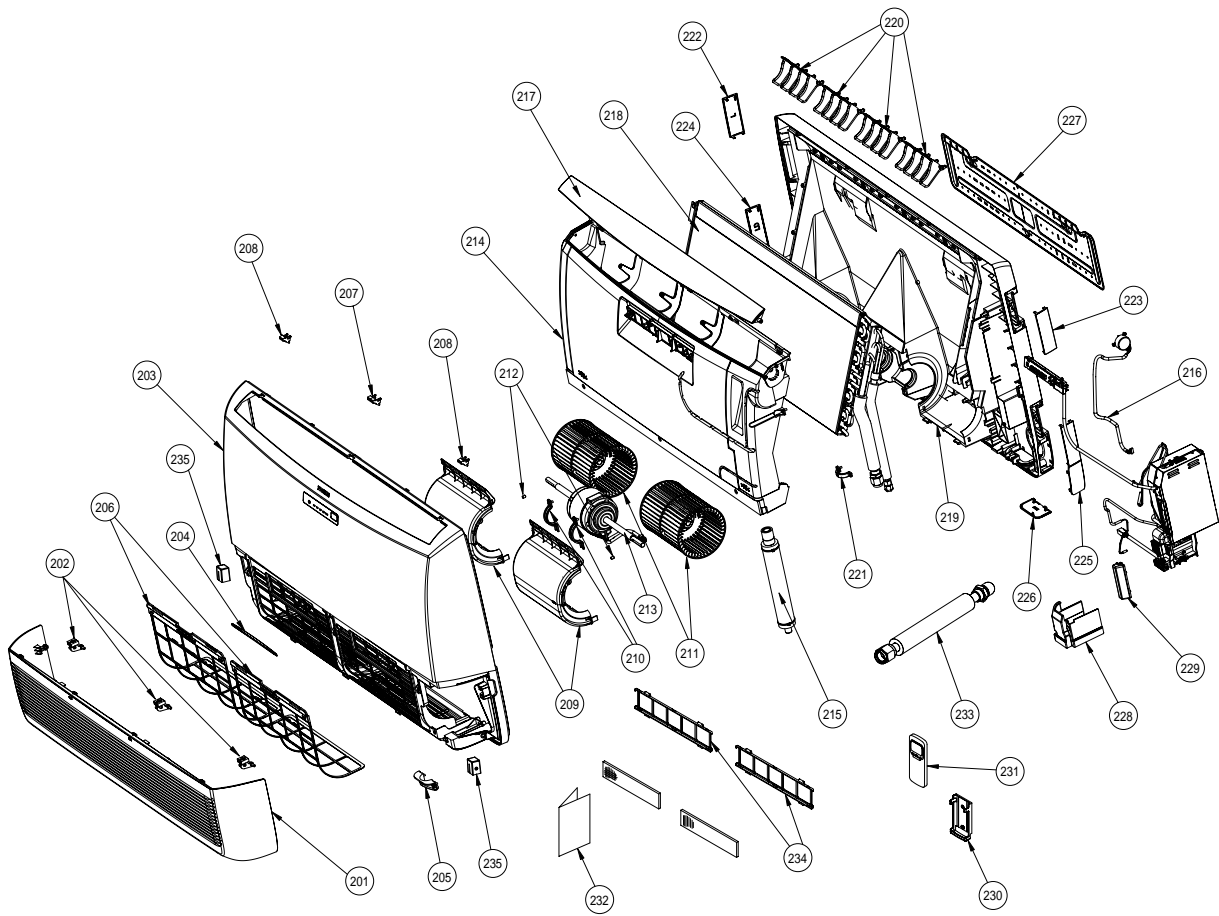

Location No.	Part No.	Description
201	43T09379	AIR-GRILLE
202	43T00445	PANEL ARM ASSY
203	43T00446	FRONT PANEL ASSY
204	43T01306	MARK
205	43T79312	DRAIN BAND
206	43T80302	AIR FILTER
207	43T00433	CAP SCREW C
208	43T00434	CAP SCREW LR
209	43T20303	FAN COVER
210	43T20318	MOTOR BAND ASSY
211	43T20317	FAN ASSY (MULTIBLADE FAN)
212	43T19309	SCREW SET (D-T)
213	43T21369	FAN MOTOR
214	43T72309	DRAIN PAN ASSY
215	43T79311	GUIDE DRAIN
216	43T21376	MOTOR; STEPPING
217	43T09378	HORIZONTAL LOUVER FLOCK
218	43T44377	REFRIGERATION ASSY (SM562XT-E)
218	43T44378	REFRIGERATION ASSY (SM802XT-E)

Location No.	Part No.	Description
219	43T03339	BACK BODY ASSY
220	43T09314	VERTICAL LOUVER
221	43T49303	PIPE HOLDER
222	43T19324	COVER BODY L
223	43T19325	COVER BODY R
224	43T19328	COVER BODY LD
225	43T19326	BUSH BODY R
226	43T19327	BUSH BODY D
227	43T82308	PLATE; INSTALLATION
228	43T60314	TERMINAL COVER
229	43T62303	CONNECTOR COVER
230	43T83003	HOLDER; REMOTE CONTROLLER
231	43T69309	WIRELESS REMOCON
233	43T49326	FLEXIBLE PIPE ASSY (SM562XT-E)
233	43T49328	FLEXIBLE PIPE ASSY (SM802XT-E)
234	43T80003	FILTER; FRAME
235	43T00447	ASM-GRILLE-STOPPER

TOSHIBA CARRIER (THAILAND) CO., LTD.

144/9 MOO 5, BANGKADI INDUSTRIAL PARK, TIVANON ROAD, TAMBOL BANGKADI,
AMPHUR MUANG, PATHUMTHANI 12000, THAILAND.