

TOSHIBA

SERVICE MANUAL

FILE NO. SVM-04022-1

AIR CONDITIONER

SPLIT WALL TYPE

RAS-13NKHD-E / RAS-13UAH-E3

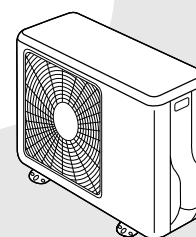
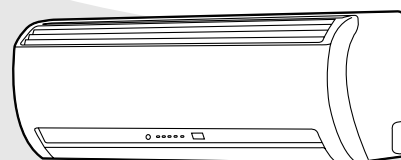
RAS-10NKHD-E / RAS-10UAH-E3

RAS-07NKHD-E / RAS-07UAH-E3

RAS-13NKD-E / RAS-13UA-E3

RAS-10NKD-E / RAS-10UA-E3

RAS-07NKD-E / RAS-07UA-E3



Revised on March, 2005

CONTENTS

- 1. SPECIFICATIONS**
- 2. CONSTRUCTION VIEWS**
 - 2-1 Indoor Unit
 - 2-2 Outdoor Unit (RAS-13UAH-E3, RAS-10UAH-E3, RAS-13UA-E3, RAS-10UA-E3)
 - 2-3 Outdoor Unit (RAS-07UAH-E3, RAS-07UA-E3)
- 3. WIRING DIAGRAM**
 - 3-1 RAS-13NKHD-E / RAS-13UAH-E3
RAS-10NKHD-E / RAS-10UAH-E3, RAS-07NKHD-E / RAS-07UAH-E3
RAS-13NKD-E / RAS-13UA-E3
 - 3-2 RAS-10NKD-E / RAS-10UA-E3, RAS-07NKD-E / RAS-07UA-E3
- 4. SPECIFICATION OF ELECTRICAL PARTS**
 - 4-1 Indoor Unit
 - 4-2 Outdoor Unit (RAS-13UAH-E3)
 - 4-3 Outdoor Unit (RAS-10UAH-E3)
 - 4-4 Outdoor Unit (RAS-07UAH-E3)
 - 4-5 Indoor Unit (RAS-13NKD-E, RAS-10NKD-E, RAS-07NKD-E)
 - 4-6 Outdoor Unit (RAS-13UA-E3)
 - 4-7 Outdoor Unit (RAS-10UA-E3)
 - 4-8 Outdoor Unit (RAS-07UA-E3)
- 5. REFRIGERATION CYCLE DIAGRAM**
 - 5-1 RAS-13NKHD-E / RAS-13UAH-E3
 - 5-2 RAS-10NKHD-E / RAS-10UAH-E3
 - 5-3 RAS-07NKHD-E / RAS-07UAH-E3
 - 5-4 RAS-13NKD-E / RAS-13UA-E3
 - 5-5 RAS-10NKD-E / RAS-10UA-E3
 - 5-6 RAS-07NKD-E / RAS-07UA-E3
- 6. CONTROL BLOCK DIAGRAM**
 - 6-1 Heat Pump model
 - 6-2 Cooling model
- 7. OPERATION DESCRIPTION**
 - 7-1 Outline of Air Conditioner Control
 - 7-2 Description of Operation Circuit
 - 7-3 Hi POWER Mode
 - 7-4 High-Temperature Limit Control
 - 7-5 Low-Temperature Limit Control
 - 7-6 Defrost Operation (NKHD Series only)
 - 7-7 Current Limit Control (NKHD Series only)
 - 7-8 Auto Restart Function
 - 7-9 Filter Check Lamp
 - 7-10 Self-Cleaning function

8. INSTALLATION PROCEDURE

- 8-1 Safety Cautions
- 8-2 Installation Diagram of Indoor and Outdoor Units
- 8-3 Installation
- 8-4 Indoor Unit
- 8-5 Outdoor Unit
- 8-6 How to Set Remote Control Selector Switch
- 8-7 Others

9. TROUBLESHOOTING CHART

- 9-1 Troubleshooting Procedure
- 9-2 Basic Check Items
- 9-3 Primary Judgement
- 9-4 Self-Diagnosis by Remote Control (Check Code)
- 9-5 Troubleshooting Flowcharts
- 9-6 Troubleshooting for Remote Control (Including The Indoor P.C. Board)
- 9-7 Troubleshooting for Air Purifier and Minus Ion

10. PART REPLACEMENT

- 10-1 Indoor Unit
- 10-2 Outdoor Unit

11. EXPLODED VIEWS AND PARTS LIST

- 11-1 Indoor Unit (E-Parts Assy)
- 11-2 Indoor Unit
- 11-3 Outdoor Unit (RAS-13UAH-E3)
- 11-4 Outdoor Unit (RAS-10UAH-E3)
- 11-5 Outdoor Unit (RAS-07UAH-E3)
- 11-6 Outdoor Unit (RAS-13UA-E3)
- 11-7 Outdoor Unit (RAS-10UA-E3)
- 11-8 Outdoor Unit (RAS-07UA-E3)

1. SPECIFICATIONS

ITEM	MODEL	RAS-13NKHD-E/ RAS-13UAH-E3				RAS-13NKD-E / RAS-13UA-E3	
		Cooling		Heating		Cooling	
Capacity	kW	220 V	240 V	220 V	240 V	220 V	240 V
		3.55	3.60	4.40	4.45	3.70	3.75
Power source	Phase	1∅					
	V	220 – 240					
	Hz	50					
Power consumption	kW	1.27	1.32	1.26	1.33	1.24	1.28
Power factor	%	98	96	98	96	98	95
Running current	Indoor	0.15					
	Outdoor	A	5.75	5.60	5.70	5.65	5.75
Starting current	A	25				24	
Moisture removal	lit/h	2.0					
Noise	Indoor (H/M/L)	41/35/31					
	Outdoor (220 – 240 V)	dB	49	51	49	51	47
Refrigerant	Name of refrigerant	R22					
	Rated amount	kg	1.00			0.80	
Refrigerant control		Capillary tube					
Interconnection pipe	Gas side size	mm	∅12.7				
	Connection type		Flare connection				
	Liquid side size	mm	∅6.35				
	Connection type		Flare connection				
	Maximum length (One way)	m	15*1				
	Maximum height difference	m	6				
INDOOR UNIT		RAS-13NKHD-E				RAS-13NKD-E	
Dimensions	Height	mm	275				
	Width	mm	790				
	Depth	mm	218				
Net weight	kg	10					
Evaporator type		Finned tube					
Indoor fan type		Cross flow fan					
Air volume	High fan	m ³ /h	630		650		630
	Medium fan	m ³ /h	520		550		520
	Low fan	m ³ /h	430		490		430
Fan motor output	W	20					
Air filter		Honeycomb woven filter with PP frame					
OUTDOOR UNIT		RAS-13UAH-E3				RAS-13UA-E3	
Dimensions	Height	mm	550				
	Width	mm	780				
	Depth	mm	270				
Net weight	kg	37				34	
Condenser type		Finned tube					
Outdoor fan type		Propeller fan					
Airflow volume	m ³ /h	2120	2200	2120	2200	2030	2150
Fan motor output	W	42				30	
Compressor	Model	PH170T2-4L2				PH225X2C-4FT	
	Output	W	1100				
Safety device		Fuse, Overload relay					
Louver type		Automatic louver					
Usable outdoor temperature range	°C	15 ~ 43		-10 ~ 24		15 ~ 43	

ITEM	MODEL	RAS-10NKHD-E / RAS-10UAH-E3				RAS-10NKD-E / RAS-10UA-E3		
		Cooling		Heating		Cooling		
Capacity	kW	220 V	240 V	220 V	240 V	220 V	240 V	
		2.70	2.75	3.12	3.15	2.65	2.70	
Power source	Phase	1 \emptyset						
	V	220 – 240						
	Hz	50						
Power consumption	kW	1.00	1.05	0.89	0.91	0.80	0.85	
Power factor	%	95	92	94	91	97	95	
Running current	Indoor	0.15						
	Outdoor	A	4.65	4.60	4.15	4.00	3.60	3.58
Starting current	A	19				16		
Moisture removal	lit/h	1.2						
Noise	Indoor (H/M/L)	39/33/26						
	Outdoor (220 – 240 V)	dB	47	49	47	49	44	45
Refrigerant	Name of refrigerant	R22						
	Rated amount	kg	0.76			0.65		
Refrigerant control		Capillary tube						
Interconnection pipe	Gas side size	mm	\emptyset 9.52					
	Connection type		Flare connection					
	Liquid side size	mm	6.35					
	Connection type		Flare connection					
	Maximum length (One way)	m	10*1					
	Maximum height difference	m	5					
INDOOR UNIT		RAS-10NKHD-E			RAS-10NKD-E			
Dimensions	Height	mm	275					
	Width	mm	790					
	Depth	mm	218					
Net weight	kg	10						
Evaporator type		Finned tube						
Indoor fan type		Cross flow fan						
Air volume	High fan	m ³ /h	570		610		610	
	Medium fan	m ³ /h	460		520		460	
	Low fan	m ³ /h	340		400		340	
Fan motor output	W	20						
Air filter		Honeycomb woven filter with PP frame						
OUTDOOR UNIT		RAS-10UAH-E3			RAS-10UA-E3			
Dimensions	Height	mm	550					
	Width	mm	780					
	Depth	mm	270					
Net weight	kg	31			30			
Condenser type		Finned tube						
Outdoor fan type		Propeller fan						
Airflow volume	m ³ /h	1740	1850	1740	1850	1740	1850	
Fan motor output	W	20						
Compressor	Model	PH120T1-4C			PH102T1-4CH			
	Output	W	750					
Safety device		Fuse, Overload relay						
Louver type		Automatic louver						
Usable outdoor temperature range	°C	15 ~ 43		-10 ~ 24		15 ~ 43		

ITEM	MODEL		RAS-07NKHD-E				RAS-07NKD-E	
			RAS-07UAH-E3				RAS-07UA-E3	
			Cooling		Heating		Cooling	
Capacity	kW	220V	240V	220V	240V	220V	240V	
		2.00	2.05	2.20	2.25	2.10	2.15	
Power source	Phase	1Ø□						
	V	220 – 240						
	Hz	50						
Power consumption	kW	0.69	0.76	0.60	0.65	0.60	0.64	
Power factor	%	98	97	97	95	92	89	
Running current	Indoor	0.15						
	Outdoor	A	3.05	3.10	2.65	2.70	2.80	2.85
Starting current	A	13				11		
Moisture removal	lit/h	0.8						
Noise	Indoor (H/M/L)	dB						
	Outdoor (220-240V)	dB	44	45	45	46	44	45
Refrigerant	Name of refrigerant		R-22					
	Rated amount	kg	0.62			0.57		
Refrigerant control		Capillary tube						
Interconnection pipe	Gas side size	mm	□ 9.52					
	Connection type		Flare connection					
	Liquid side size	mm	□ 6.35					
	Connection type		Flare connection					
	Maximum length (One way)	m	10*1					
	Maximum height difference	m	5					
INDOOR UNIT		RAS-07NKHD-E				RAS-07NKD-E		
Dimensions	Height	mm	275					
	Width	mm	790					
	Depth	mm	218					
Net weight	kg	10						
Evaporator type		Finned tube						
Indoor fan type		Cross flow fan						
Air volume	High fan	m ³ /h	570	610		570		
	Medium fan	m ³ /h	460	490		460		
	Low fan	m ³ /h	340	400		340		
Fan motor output	W	20						
Air filter		Honeycomb woven filter with PP frame						
OUTDOOR UNIT		RAS-07UAH-E3				RAS-07UA-E3		
Dimensions	Height	mm	530					
	Width	mm	660					
	Depth	mm	240					
Net weight	kg	27			26			
Condenser type		Finned tube						
Outdoor fan type		Propeller fan						
Airflow volume	m ³ /h	1280	1360	1280	1360	1280	1360	
Fan motor output	W	20						
Compressor	Model	PH80T1-4C						
	Output	W	605					
Safety device		Fuse, Overload relay						
Louver type		Automatic louver						
Usable outdoor temperature range		°C	15 ~ 43	-10 ~ 24		15 ~ 43		

Note : 1

- Capacity is based on the following temperature conditions.

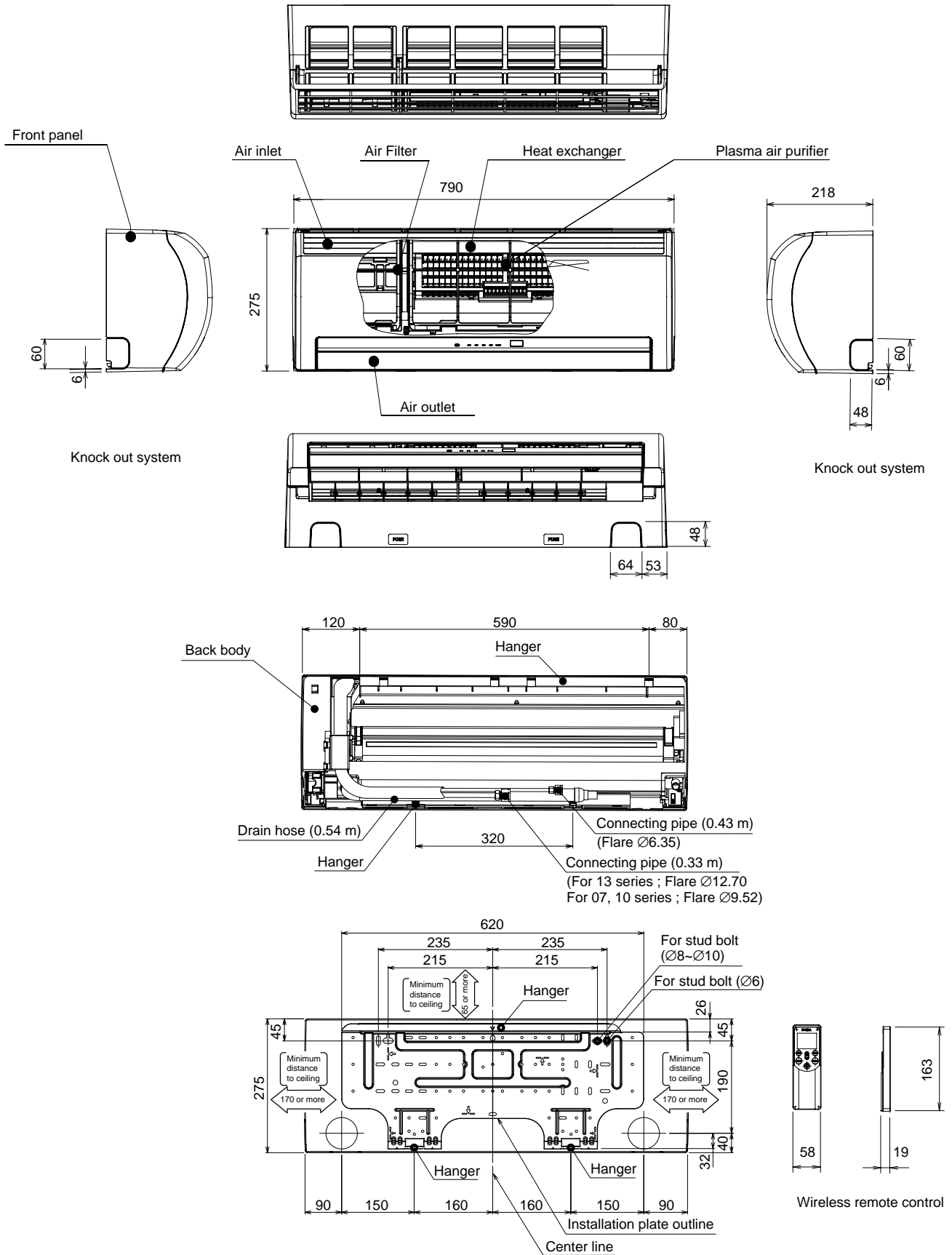
Temperature		Condition	JIS B8615-1	
			Cooling	Heating
Indoor unit inlet air temperature	(DB)		27°C	20°C
	(WB)		19°C	15°C
Outdoor unit inlet air temperature	(DB)		35°C	7°C
	(WB)		24°C	6°C

Note : 2

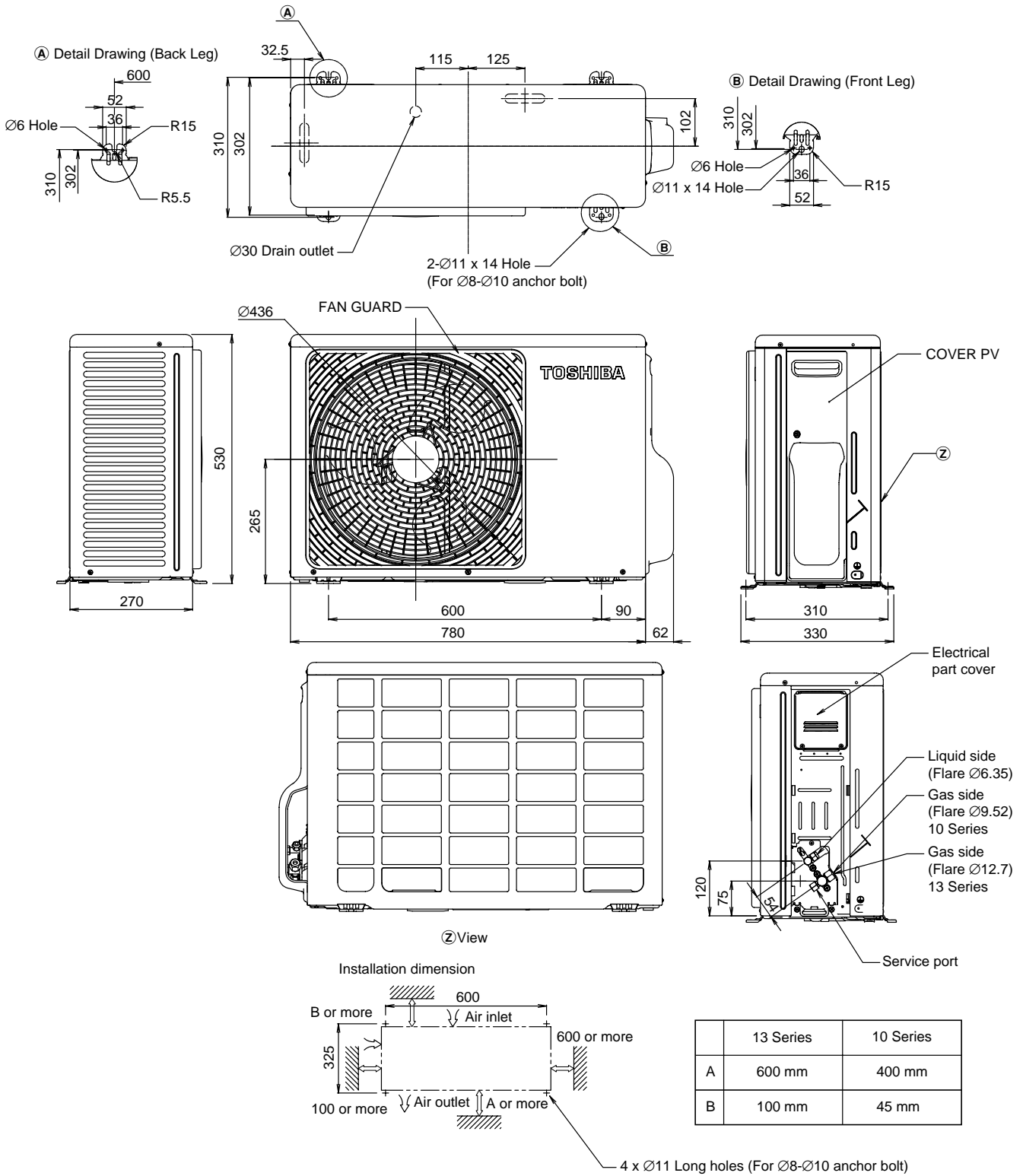
- *1 No need to charge extra refrigerant.

2. CONSTRUCTION VIEWS

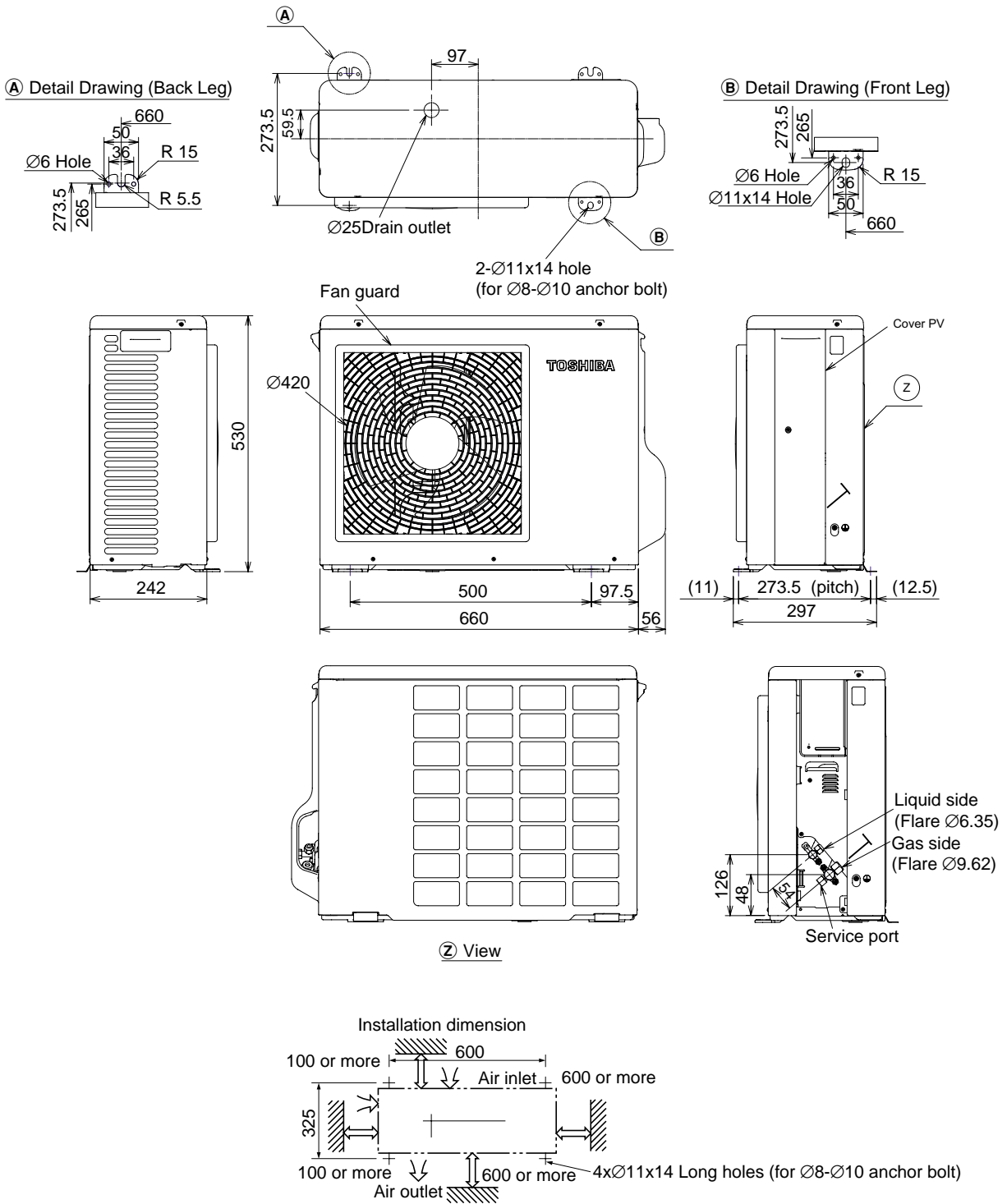
2-1. Indoor Unit



2-2. Outdoor Unit (RAS-13UAH-E3, RAS-10UAH-E3, RAS-13UA-E3, RAS-10UA-E3)

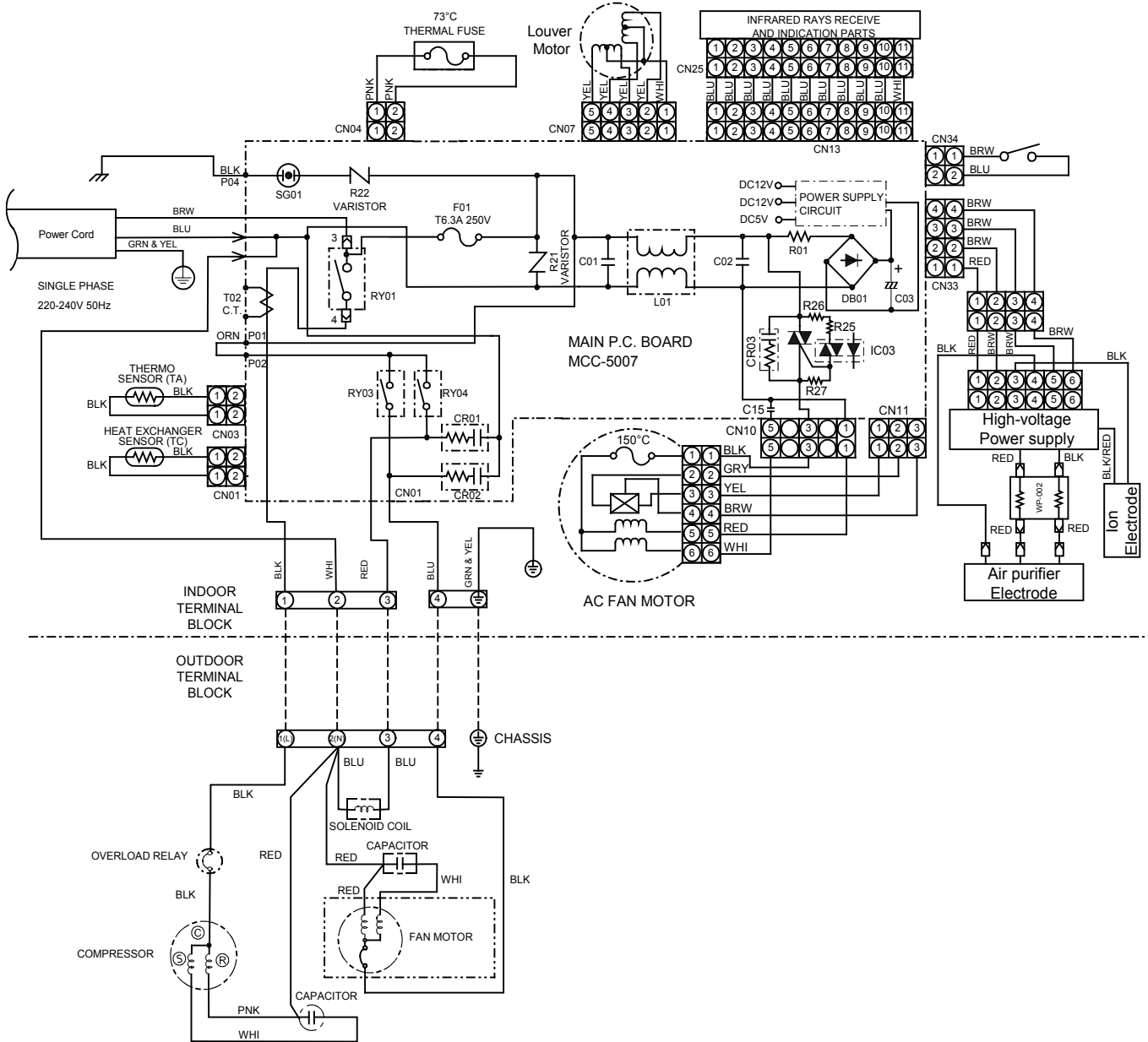


2-3. Outdoor Unit (RAS-07UAH-E3, RAS-07UA-E3)

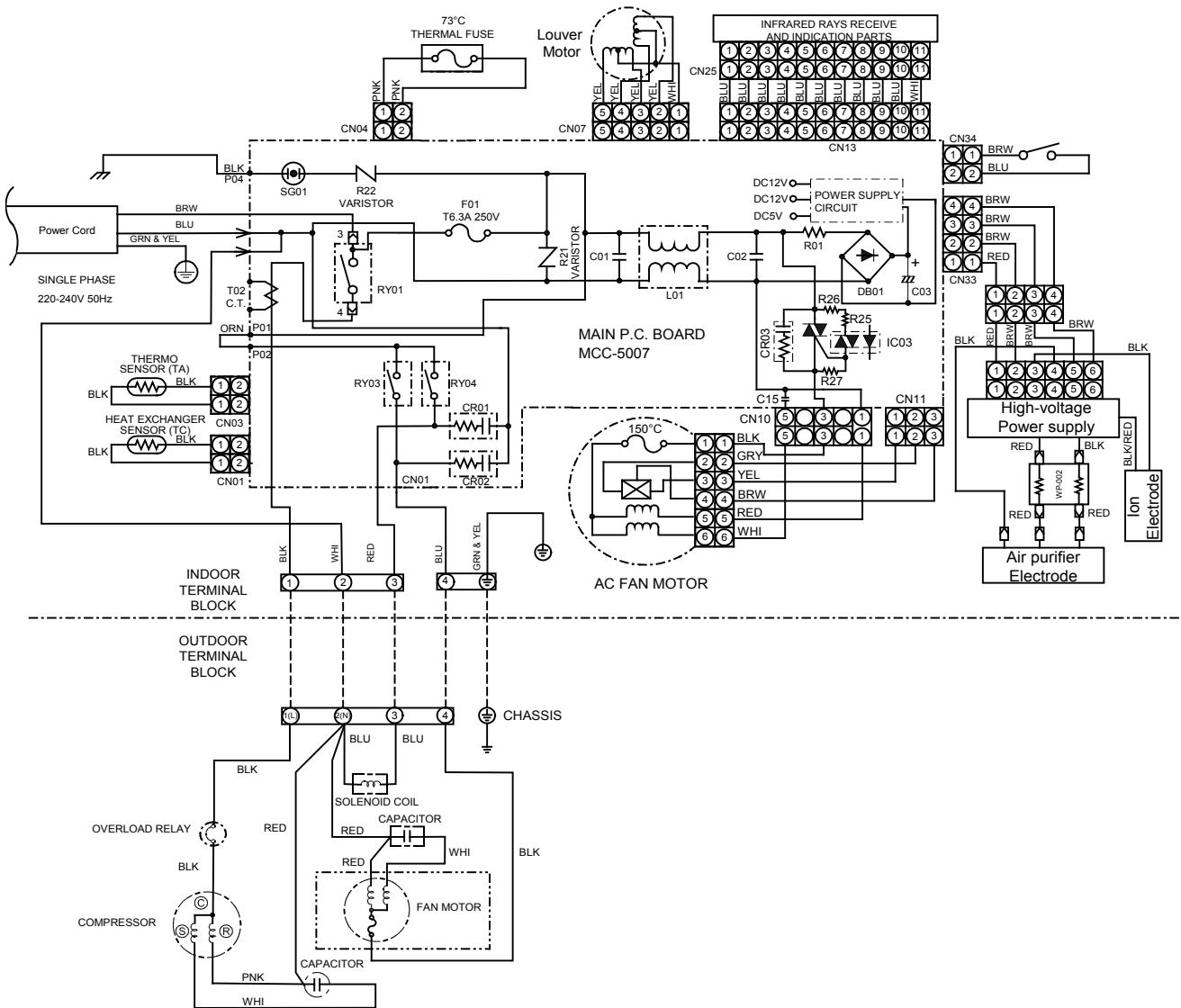


3. WIRING DIAGRAM

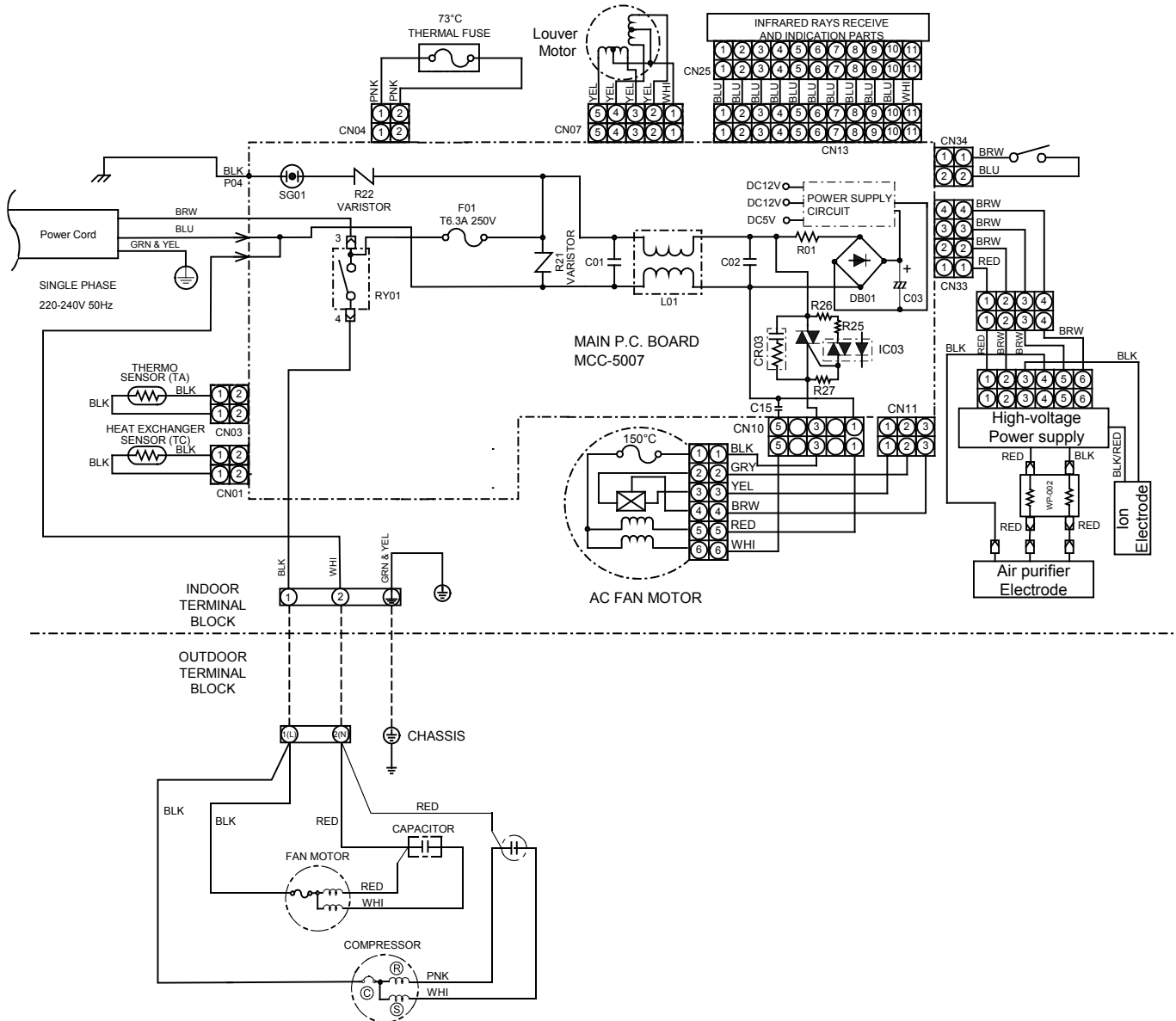
3-1. RAS-13NKHD-E / RAS-13UAH-E3



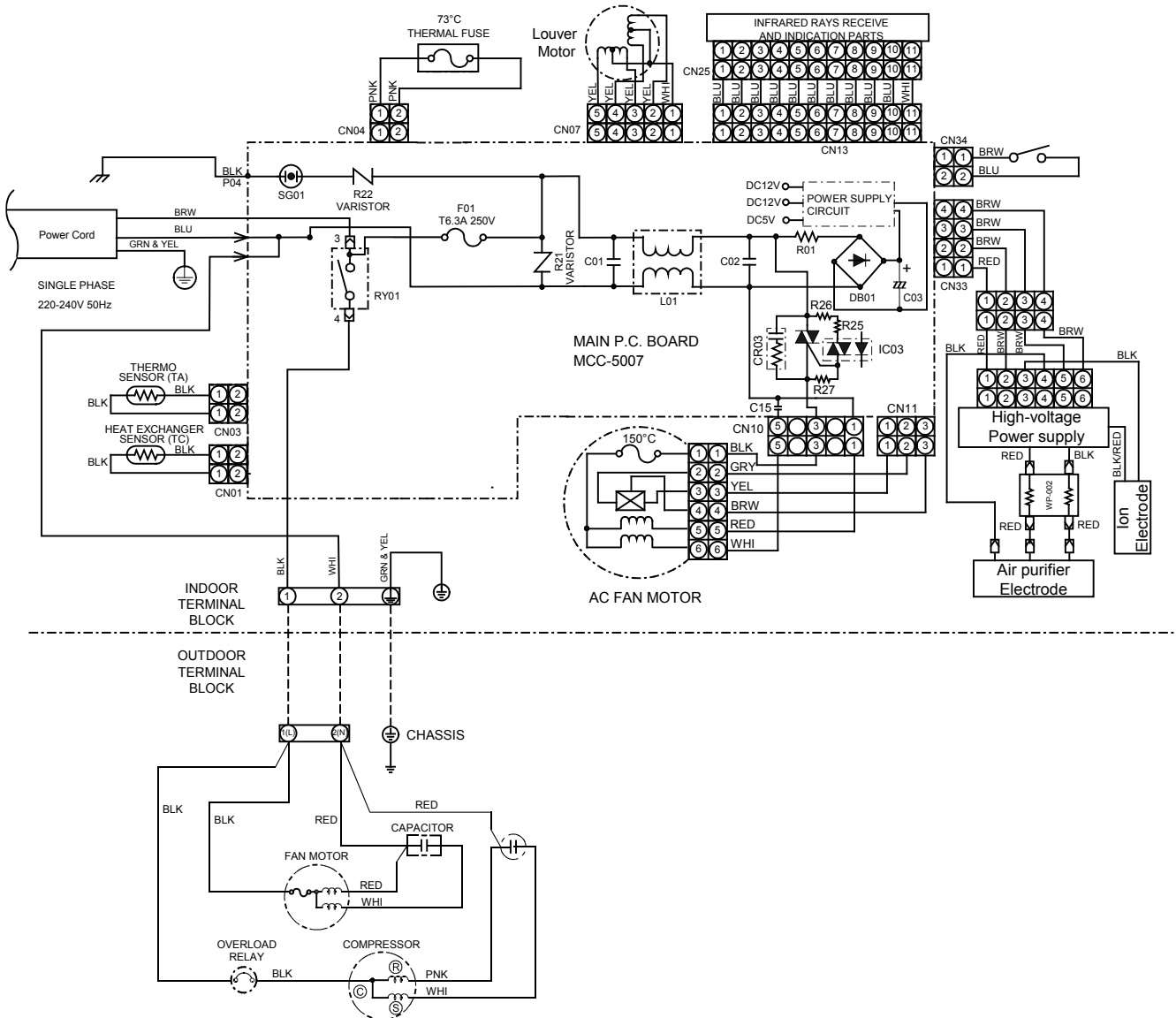
**3-2. RAS-10NKHD-E / RAS-10UAH-E3
RAS-07NKHD-E / RAS-07UAH-E3**



3-3. RAS-13NKD-E / RAS-13UA-E3



**3-4. RAS-10NKD-E / RAS-10UA-E3
RAS-07NKD-E / RAS-07UA-E3**



4. SPECIFICATION OF ELECTRICAL PARTS

4-1. Indoor Unit (RAS-13NKHD-E, RAS-10NKHD-E, RAS-07NKHD-E)

No.	Parts name	Type	Specifications
1	Fan motor (for indoor)	SKF-220-20-4A-1	AC Motor with 150°C thermo fuse
2	Thermo sensor (TA-sensor)	—————	10kΩ at 25°C
3	Switching transformer	SWT-77	
4	Microcontroller unit (IC30)	TMP87CM40AN	
5	Heat exchanger sensor (TC-sensor)	—————	10kΩ at 25°C
6	Line filter (L01)	LC*SS11V-06270	27mH, 600mA
7	Bridge rectifier (DB01)	D3SBA60	4A, 600 V
8	Capacitor (C03)	KHM400VSSN47M225	47μF, 400 V
9	Fuse (F01)	BET6.3A	T6.3A, 250VAC
10	Varistor (R21, R22)	15G561K320	560 V
11	Louver motor	MP24Z	12VDC
12	Relay (Comp., RY01)	DI1U	Rating 25A/AC250 V, 12VDC
13	Relay (Fan, RY03)	G5N-1A	Rating 3A/AC250V, 12VDC
14	Relay (Solenoid, RY04)	G5N-1A	Rating 3A/AC250V, 12VDC

4-2. Outdoor Unit (RAS-13UAH-E3)

No.	Parts name	Type	Specifications	
1	Compressor	PH170T2-4L2	Output (Rated) 1100 W, 2 poles, 1 phase, 220 – 240 V, 50Hz	
			Winding resistance (Ω) (at 20°C)	C-R 2.22
2	Fan motor (for outdoor)	HF-240-42A	Output (Rated) 42 W, 6 poles, 1 phase, 220 – 240 V, 50Hz	
			Winding resistance (Ω) (at 20°C)	Red-Black 176.2
3	Running capacitor (for fan motor)	DS451155CBPQC	AC 450 V, 1.5μF	
4	Running capacitor (for compressor)	DS371356CPNB	AC 370 V, 35μF	
5	Overload relay	RAT00AL	Bimetal of current control : U/T : 8.6A (100°C), OPEN : 150±5°C, CLOSE : 70±11°C Bimetal of temperature control : OPEN : 130±5°C, CLOSE : 75±15°C	

4-3. Outdoor Unit (RAS-10UAH-E3)

No.	Parts name	Type	Specifications		
1	Compressor	PH120T1-4C	Output (Rated) 750 W, 2 poles, 1 phase, 220 – 240 V, 50Hz		
			Winding resistance (Ω) (at 20°C)	C-R	C-S
				4.53	8.73
2	Fan motor (for outdoor)	HF-240-20B or SKF-240-20B	Output (Rated) 20 W, 6 poles, 1 phase, 220 – 240 V, 50Hz		
			Winding resistance (Ω) (at 20°C)	Red-Black	White-Black
				387.3 or 235.2	466.2 or 260.1
3	Running capacitor (for fan motor)	DS451155BPQC	AC 450 V, 1.5 μ F		
4	Running capacitor (for compressor)	DS371256CPNB	AC 370 V, 25 μ F		
5	Overload relay	JMRA99269-9200	U/T : 6.8A (90°C), OPEN : 135 \pm 5°C, CLOSE : 69 \pm 11°C		

4-4. Outdoor Unit (RAS-07UAH-E3)

No.	Parts name	Type	Specifications		
1	Compressor	PH80T1-4C	Output (Rated) 560W, 2poles, 1 phase, 220 – 240V, 50Hz		
			Winding resistance (Ω) (at 20°C)	C-R	C-S
				4.80	8.37
2	Fan motor (for outdoor)	HF-240-20B or SKF-240-20B	Output (Rated) 20W, 6poles, 1 phase, 220 – 240V, 50Hz		
			Winding resistance (Ω) (at 20°C)	Red-Black	White-Black
				387.3 or 235.2	466.2 or 260.1
3	Running capacitor (for fan motor)	DS451155CBPQC	AC 450V, 1.5 μ F		
4	Running capacitor (for compressor)	DS371256CPN	AC 370V, 25 μ F		
5	Overload relay	JMRA99208-9201	U/T: 4.2A (80°C), OPEN: 135 \pm 5°C, CLOSE: 69 \pm 11°C		

4-5. Indoor Unit (RAS-13NKD-E, RAS-10NKD-E, RAS-07NKD-E)

No.	Parts name	Type	Specifications
1	Fan motor (for indoor)	SKF-220-20-4A-1	AC Motor with 150°C thermo fuse
2	Thermo sensor (TA-sensor)	————	10kΩ at 25°C
3	Switching transformer	SWT-77	
4	Microcontroller unit (IC30)	TMP87CM40AN	
5	Heat exchanger sensor (TC-sensor)	————	10kΩ at 25°C
6	Line filter (L01)	LC*SS11V-06270	27mH, 600mA
7	Bridge rectifier (DB01)	D3SBA60	4A, 600 V
8	Capacitor (C03)	KHM400VSSN47M225	47μF, 400 V
9	Fuse (F01)	BET6.3A	T6.3A, 250VAC
10	Varistor (R21, R22)	15G561K320	560 V
11	Louver motor	MP24Z	12VDC
12	Relay (Comp., RY01)	D11U	Rating 25A/AC250 V, 12VDC

4-6. Outdoor Unit (RAS-13UA-E3)

No.	Parts name	Type	Specifications		
1	Compressor	PH225X2C-4FT	Output (Rated) 1100 W, 2 poles, 1 phase, 220 – 240 V, 50Hz		
			Winding resistance (Ω) (at 20°C)	C-R 2.35	C-S 3.33
2	Fan motor (for outdoor)	HF-240-30B	Output (Rated) 30 W, 6 poles, 1 phase, 220 – 240 V, 50Hz		
			Winding resistance (Ω) (at 20°C)	Red-Black 245	White-Black 388
3	Running capacitor	DS451155CBPQC	AC 450 V, 15μF		
4	Running capacitor (for compressor)	DS371356CPNB	AC 370 V, 35μF		

4-7. Outdoor Unit (RAS-10UA-E3)

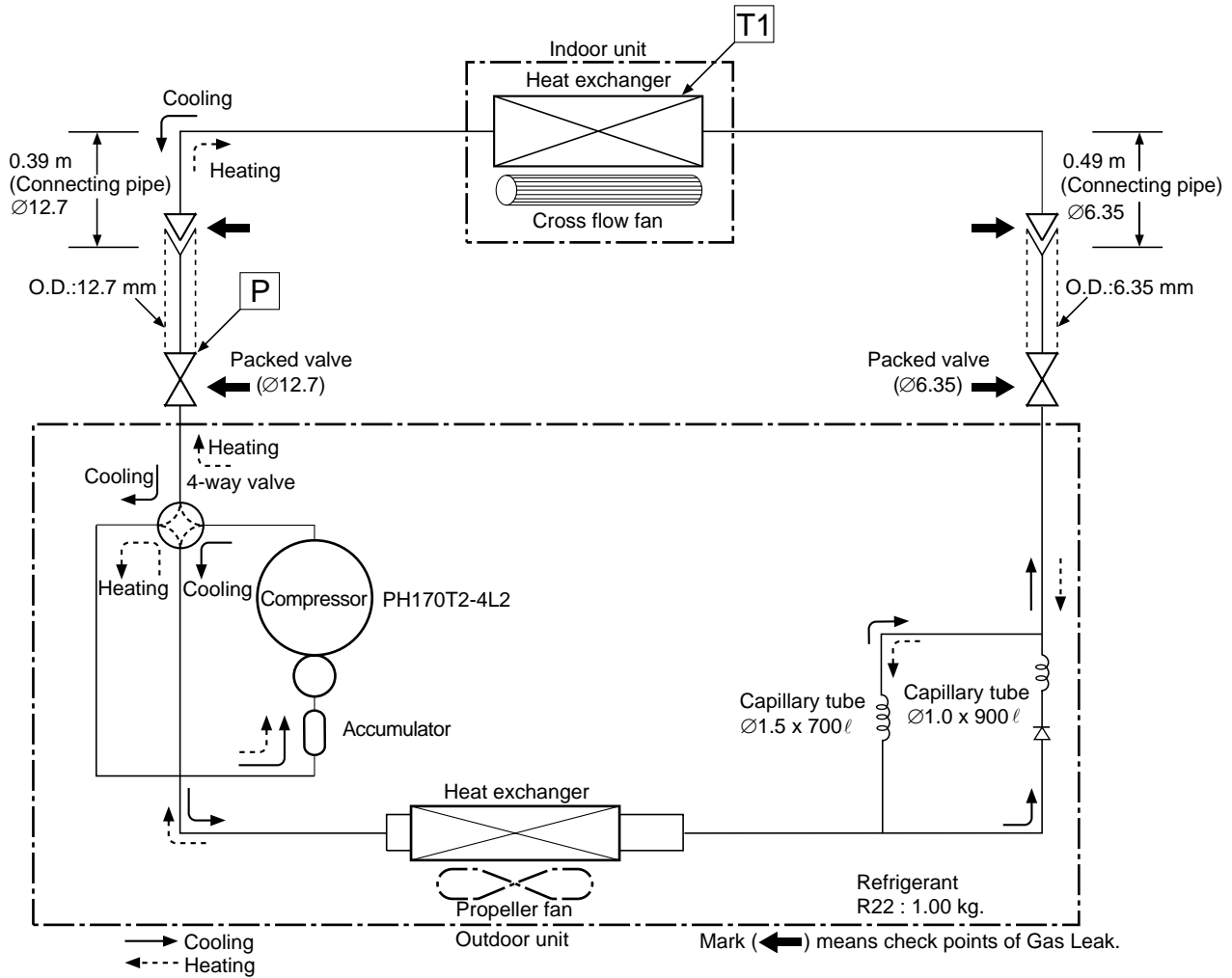
No.	Parts name	Type	Specifications		
1	Compressor	PH102T1-4CH	Output (Rated) 750 W, 2 poles, 1 phase, 220 – 240 V, 50Hz		
			Winding resistance (Ω)	C-R	C-S
			(at 20°C)	3.17	5.18
2	Fan motor (for outdoor)	HF-240-20B or SKF-240-20B	Output (Rated) 20 W, 6 poles, 1 phase, 220 – 240 V, 50Hz		
			Winding resistance (Ω)	Red-Black	White-Black
			(at 20°C)	387.3 or 235.2	466.2 or 260.1
3	Running capacitor (for fan motor)	DS451155BPQC	AC 450 V, 1.5 μ F		
4	Running capacitor (for compressor)	DS371256CPNB	AC 370 V, 25 μ F		

4-8. Outdoor Unit (RAS-07UA-E3)

No.	Parts name	Type	Specifications		
1	Compressor	PH80T1-4C	Output (Rated) 560W, 2poles, 1 phase, 220 – 240V, 50Hz		
			Winding resistance (Ω)	C-R	C-S
			(at 20°C)	4.80	8.37
2	Fan motor (for outdoor)	HF-240-20B or SKF-240-20B	Output (Rated) 20W, 6poles, 1 phase, 220 – 240V, 50Hz		
			Winding resistance (Ω)	Red-Black	White-Black
			(at 20°C)	387.3 or 235.2	466.2 or 260.1
3	Running capacitor (for fan motor)	DS451155CBPQC	AC 450V, 1.5 μ F		
4	Running capacitor (for compressor)	DS371156CPNB	AC 370V, 15 μ F		
5	Overload relay	LAAO00A	U/T: 9.0A (80°C), OPEN: 135 \pm 5°C, CLOSE: 75 \pm 11°C		

5. REFRIGERATION CYCLE DIAGRAM

5-1. RAS-13NKHD-E / RAS-13UAH-E3



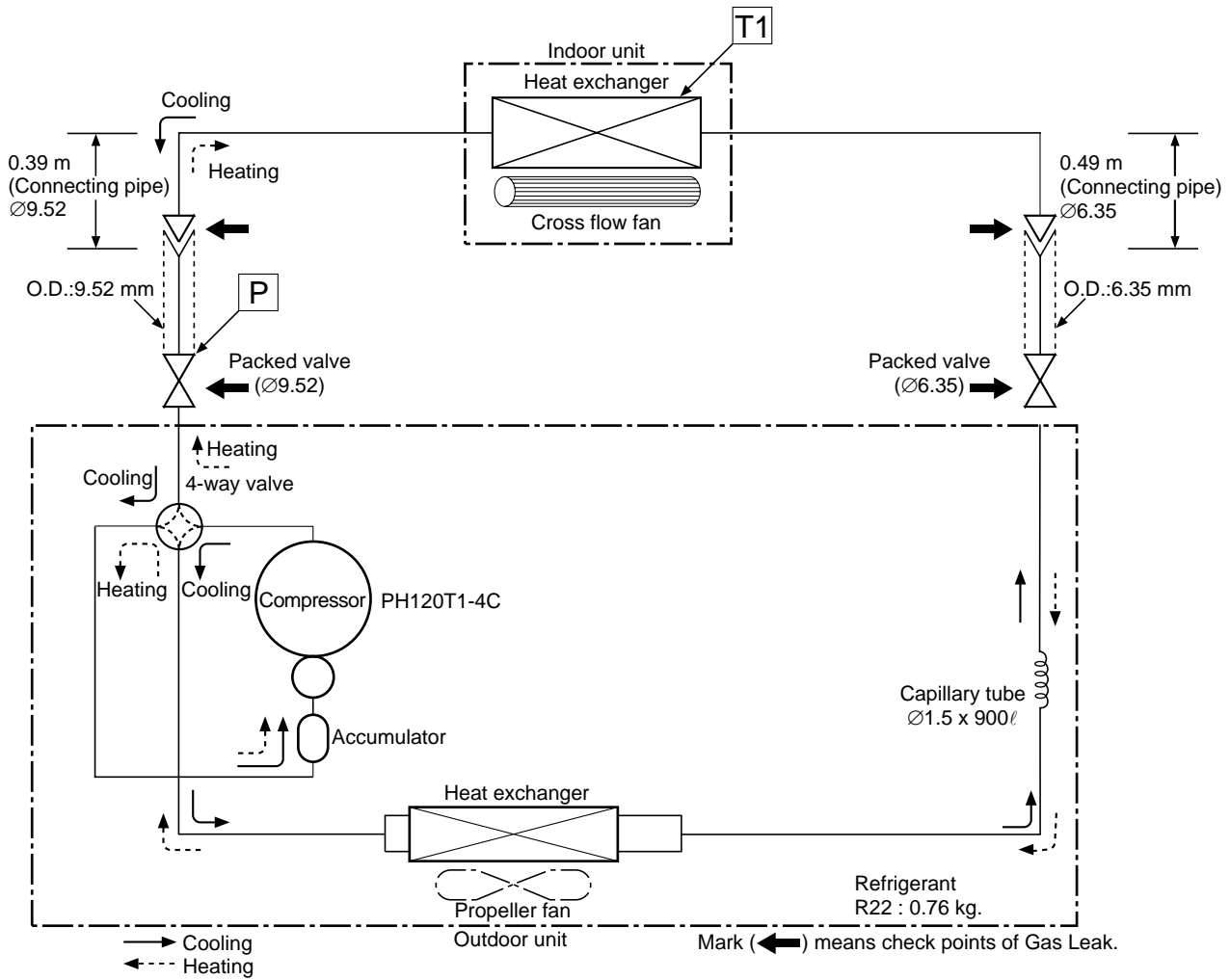
50Hz		Standard pressure P (MPaG)	Surface temp. of heat exchanger interchanging pipe T1 (°C)	Fan speed (indoor)	Ambient temp. conditions DB/WB (°C)	
					Indoor	Outdoor
Heating	Standard	1.84	46.0	High	20/15	7/6
	Overload*1	2.00 ~ 2.42	52.0 ~ 59.0	Low	27/-	24/18
	Low temperature	1.50	38.0	High	20/-	-10/-10
Cooling	Standard	0.49	10.0	High	27/19	35/24
	Overload	0.60	15.0	High	32/23	43/26
	Low temperature	0.45	2.0	Low	21/15	21/15

Note

- Measure the heat exchanger temperature at the center of U-bend. (By means of TC sensor)

*1 • During heating overload operation, a value for the high temperature limit control operation is included.

5-2. RAS-10NKHD-E / RAS-10UAH-E3



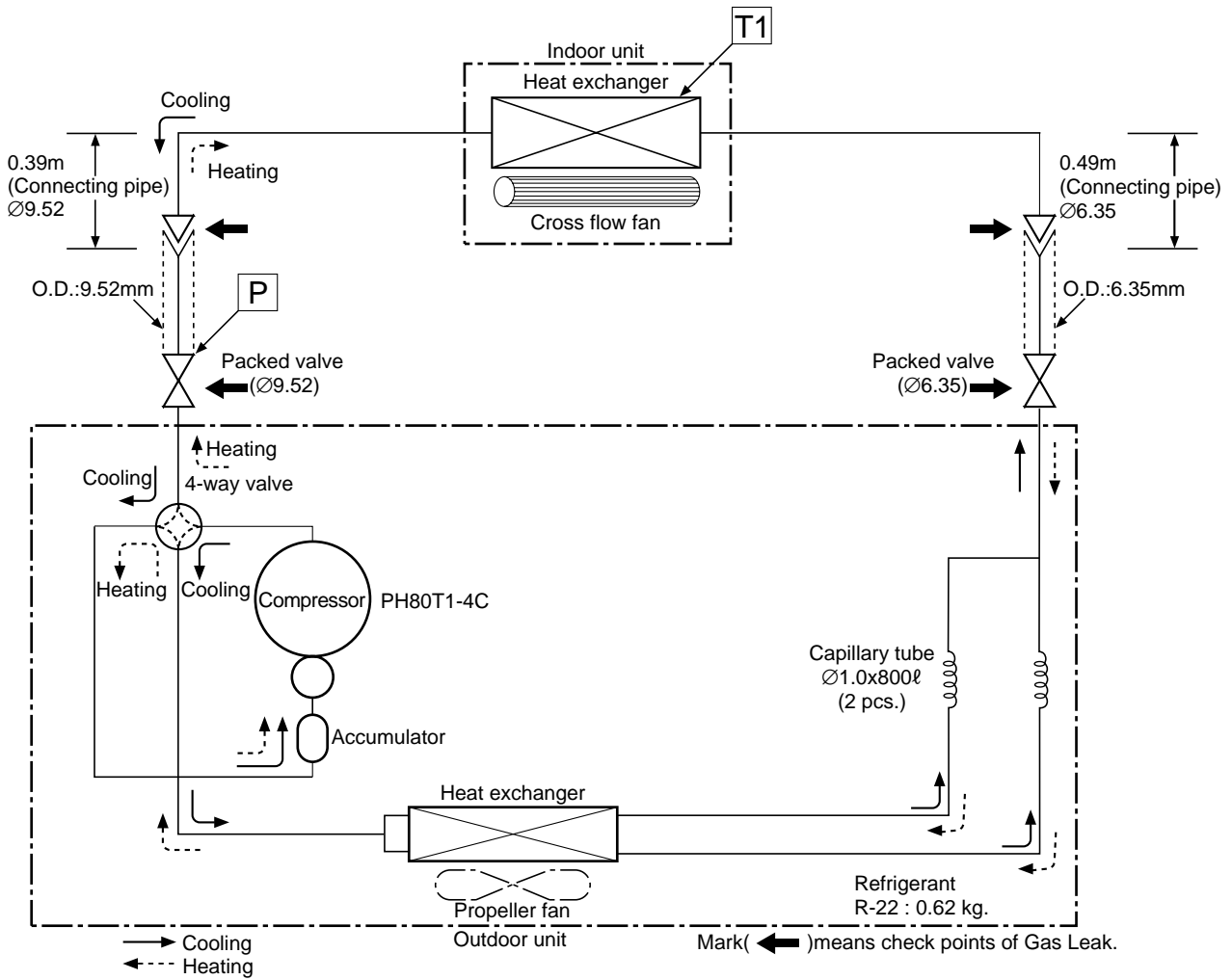
50Hz		Standard pressure [P] (MPaG)	Surface temp. of heat exchanger inter changing pipe [T1] (°C)	Fan speed (indoor)	Ambient temp. conditions DB/WB (°C)	
					Indoor	Outdoor
Heating	Standard	1.65	40.0	High	20/15	7/6
	Overload*1	2.00 ~ 2.40	52.0 ~ 59.0	Low	27/-	24/18
	Low temperature	1.40	35.0	High	20/-	-10/-10
Cooling	Standard	0.48	12.0	High	27/19	35/24
	Overload	0.58	15.0	High	32/23	43/26
	Low temperature	0.45	5.0	Low	21/15	21/15

Note

- Measure the heat exchanger temperature at the center of U-bend. (By means of TC sensor)

*1 • During heating overload operation, a value for the high temperature limit control operation is included.

5-3. RAS-07NKHD-E / RAS-07UAH-E3

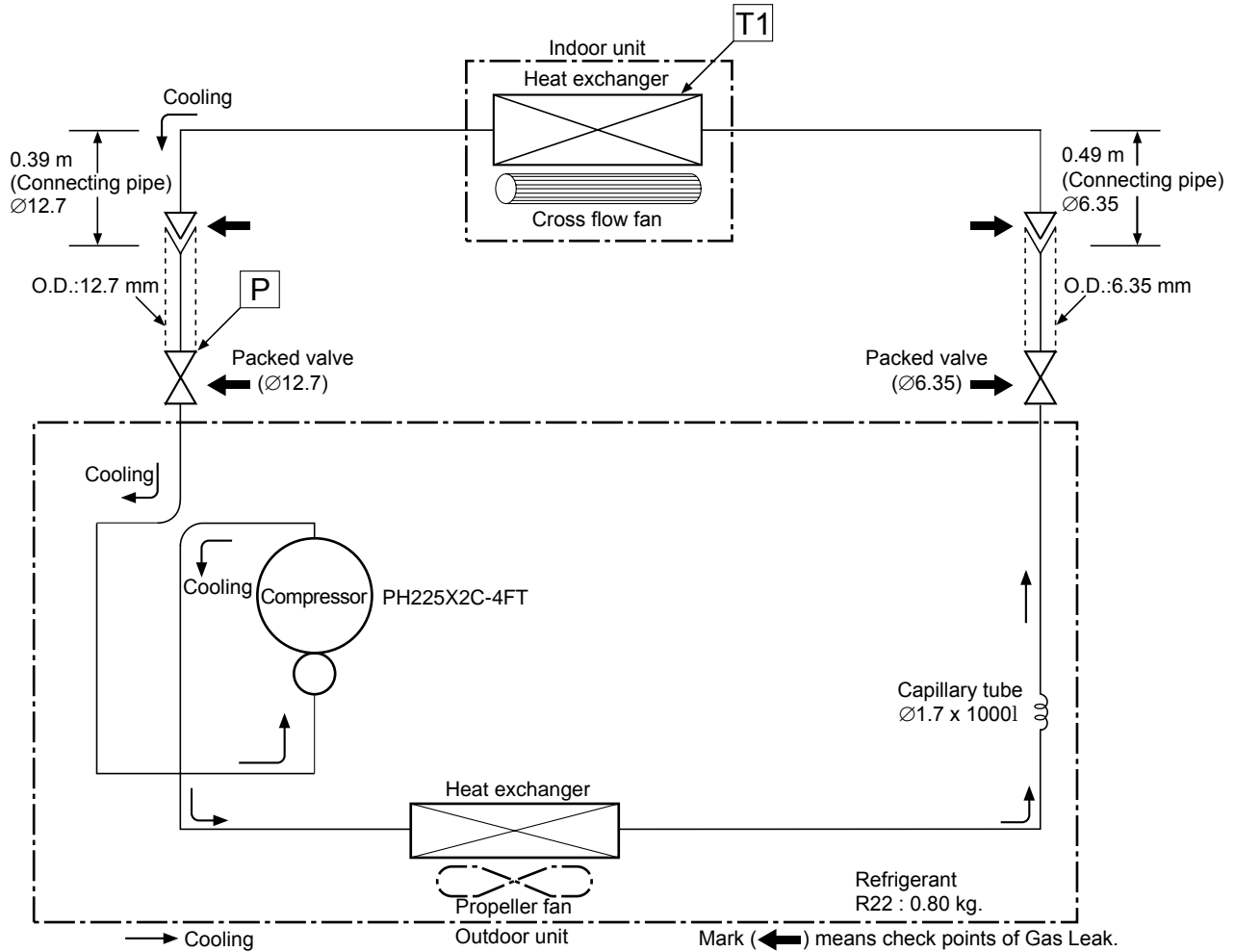


50Hz		Standard pressure [P] (MPaG)	Surface temp. of heat exchanger interchanging pipe [T1] (°C)	Fan speed (indoor)	Ambient temp. conditions DB/WB (°C)	
					Indoor	Outdoor
Heating	Standard	1.35	35.0	High	20/-	7/6
	Overload	1.85	49.0	Low	27/-	24/18
	Low temperature	1.10	30.0	High	20/-	-10/-10
Cooling	Standard	0.58	12.0	High	27/19	35/24
	Overload	0.67	16.0	High	32/23	43/26
	Low temperature	0.50	2.0	Low	21/15	21/15

Note :

- Measure the heat exchanger temperature at the center of U-bend. (By means of TC sensor)

5-4. RAS-13NKD-E / RAS-13UA-E3

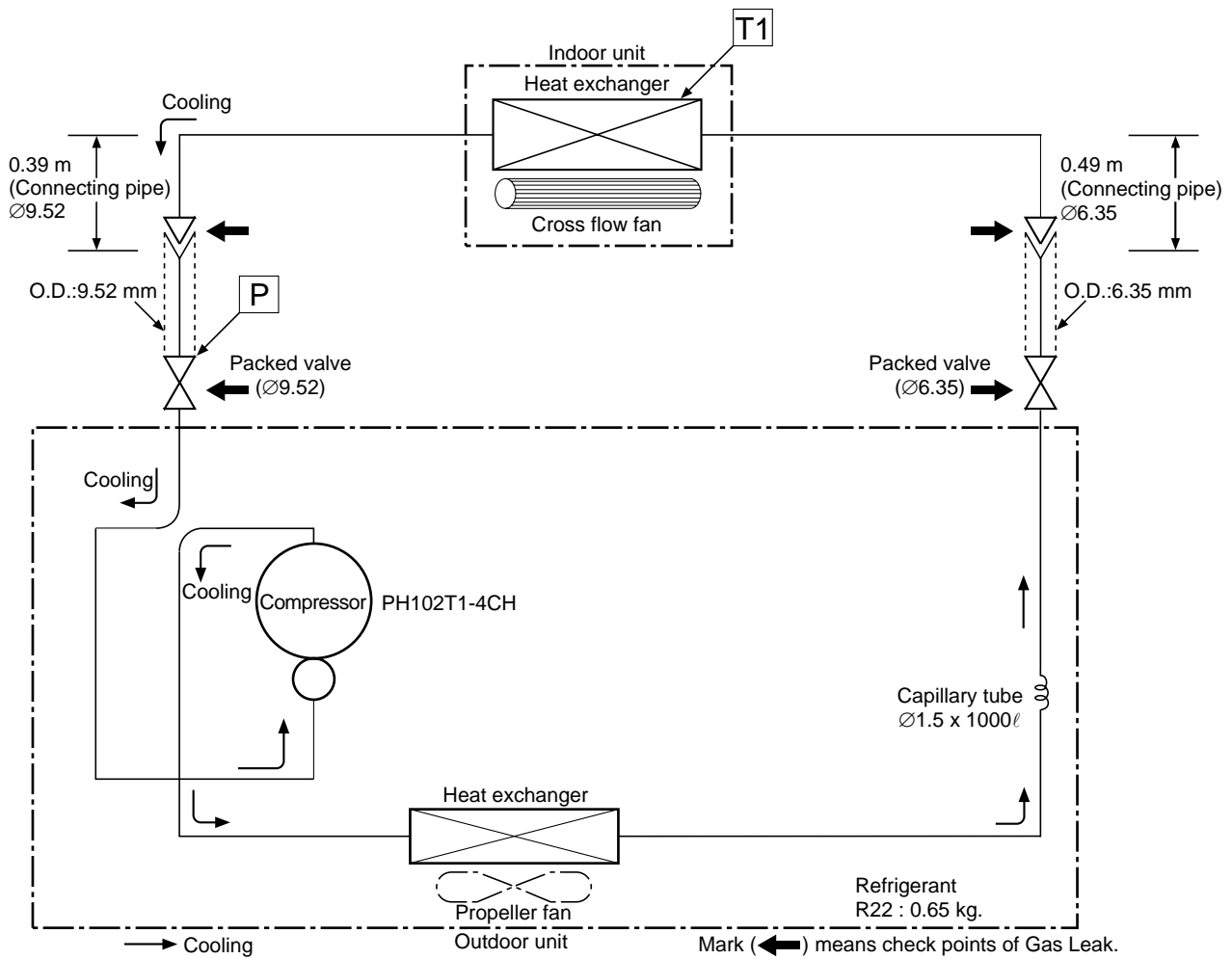


50Hz		Standard pressure P (MPaG)	Surface temp. of heat exchanger interchanging pipe T1 (°C)	Fan speed (indoor)	Ambient temp. conditions DB/WB (°C)	
					Indoor	Outdoor
Cooling	Standard	0.48	9.0	High	27/19	35/24
	Overload	0.59	15.0	High	32/23	43/26
	Low temperature	0.45	2.0	Low	21/15	21/15

Note

- Measure the heat exchanger temperature at the center of U-bend. (By means of TC sensor)

5-5. RAS-10NKD-E / RAS-10UA-E3

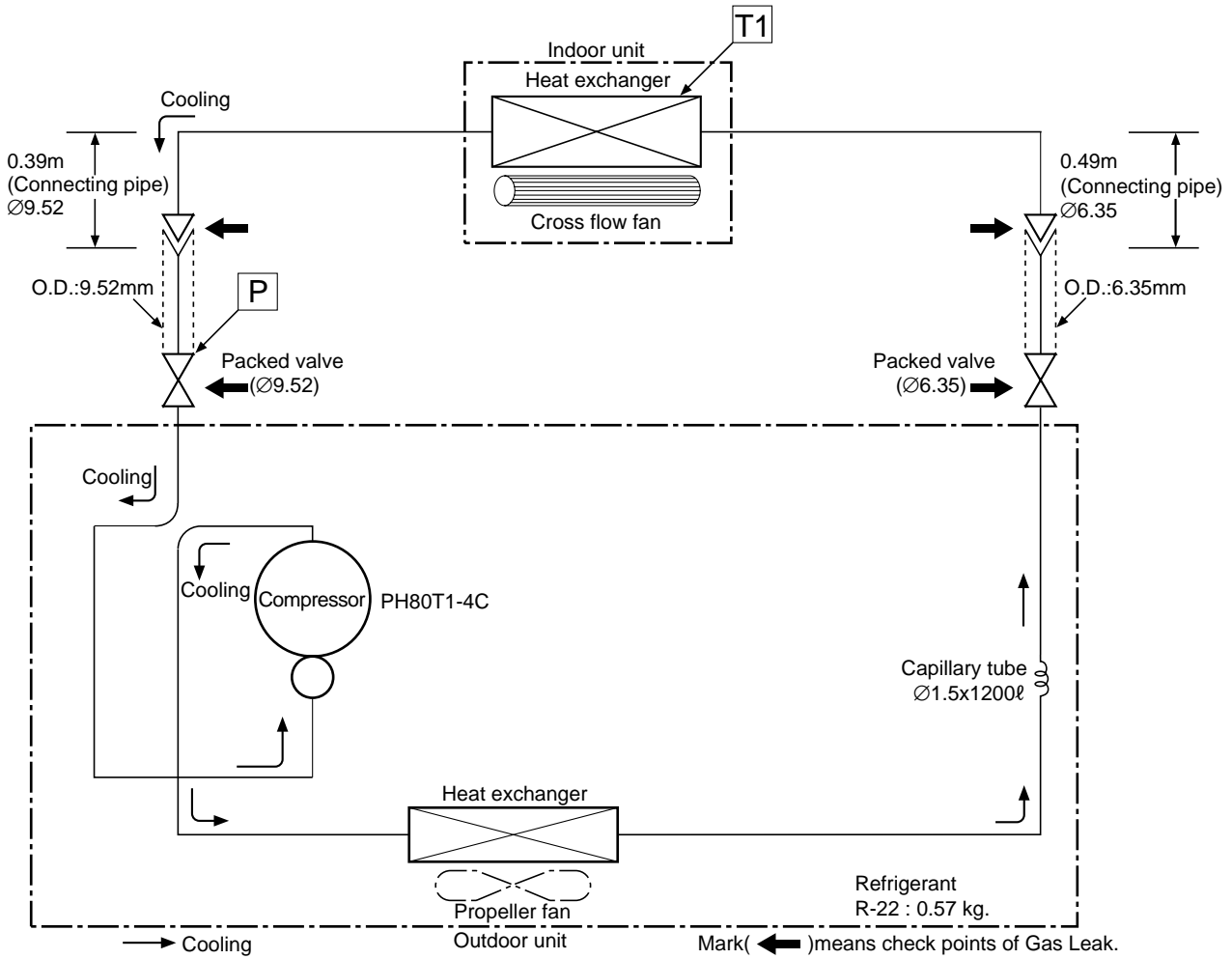


50Hz		Standard pressure P (MPaG)	Surface temp. of heat exchanger interchanging pipe T1 (°C)	Fan speed (indoor)	Ambient temp. conditions DB/WB (°C)	
					Indoor	Outdoor
Cooling	Standard	0.53	11.0	High	27/19	35/24
	Overload	0.62	16.0	High	32/23	43/26
	Low temperature	0.48	5.0	Low	21/15	21/15

Note

- Measure the heat exchanger temperature at the center of U-bend. (By means of TC sensor)

5-6. RAS-07NKD-E / RAS-07UA-E3



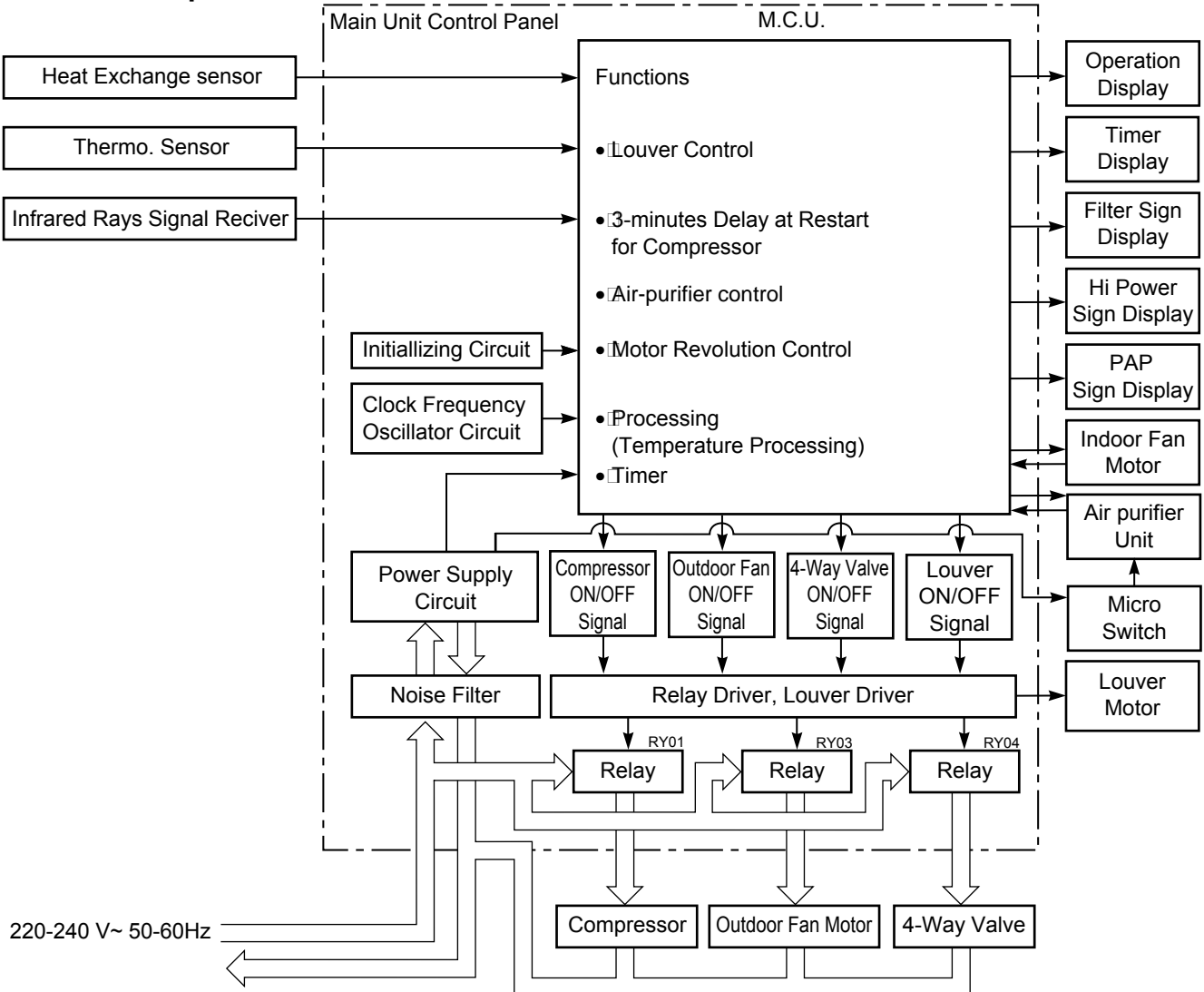
50Hz		Standard pressure P (MPaG)	Surface temp. of heat exchanger interchanging pipe T1 (°C)	Fan speed (indoor)	Ambient temp. conditions DB/WB (°C)	
					Indoor	Outdoor
Cooling	Standard	0.45	13.5	High	27/19	35/24
	Overload	0.69	18.0	High	32/23	43/26
	Low temperature	0.32	2.0	Low	21/15	21/15

Note :

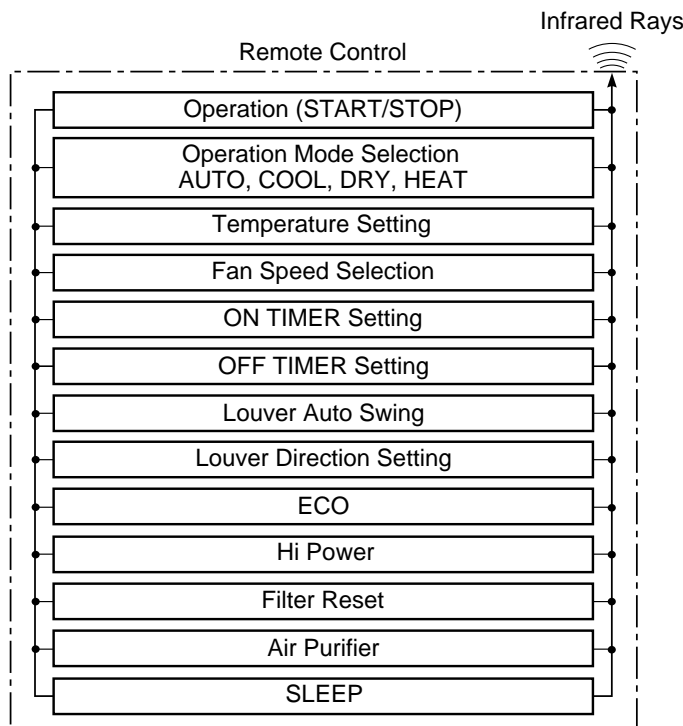
- Measure the heat exchanger temperature at the center of U-bend. (By means of TC sensor)

6. CONTROL BLOCK DIAGRAM

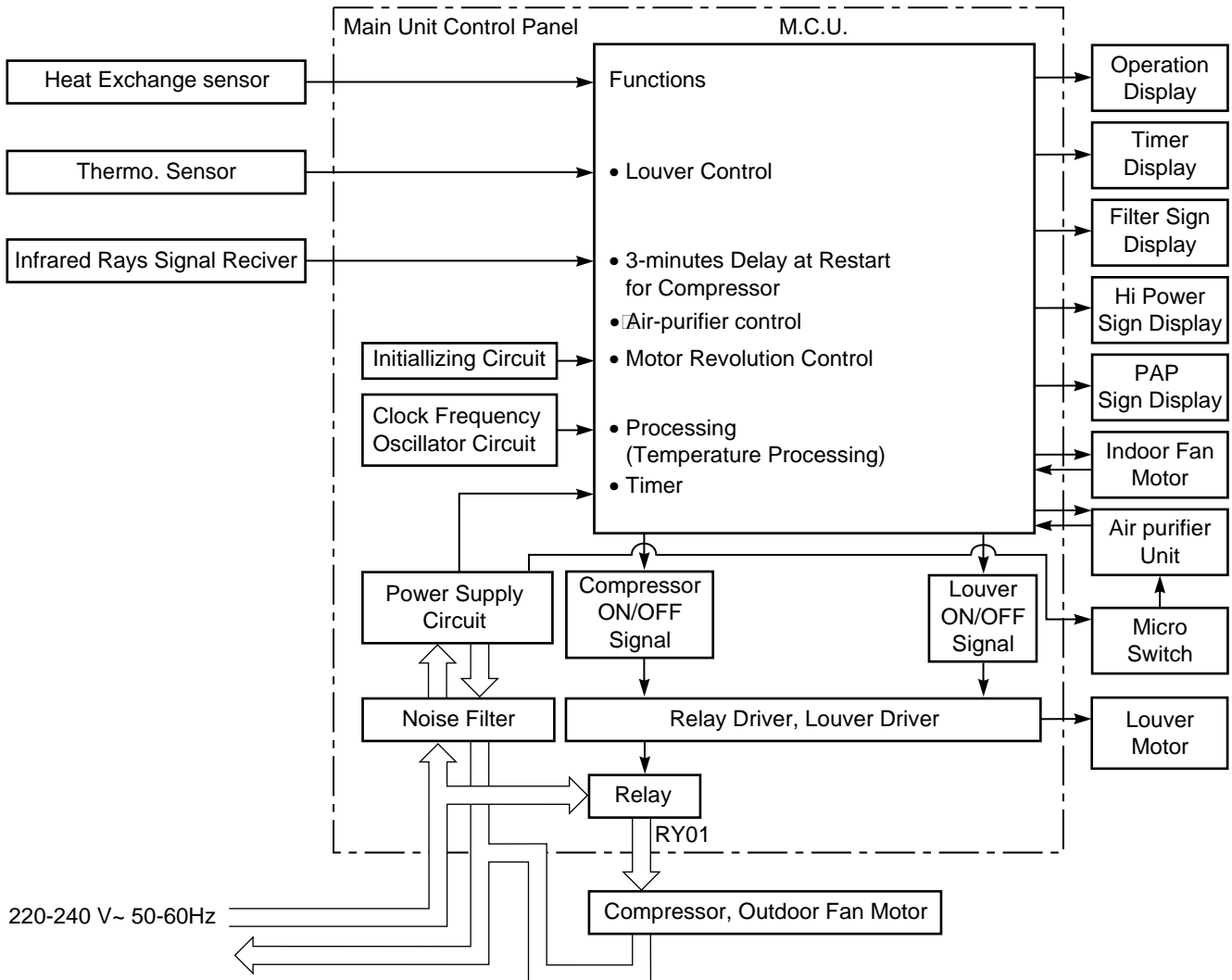
6-1. Heat Pump model



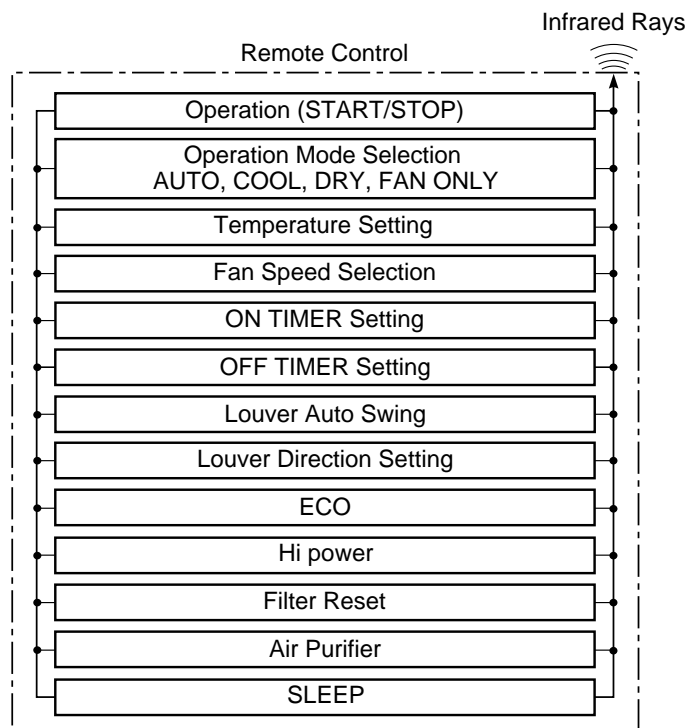
REMOTE CONTROL



6-2. Cooling model



REMOTE CONTROL



7. OPERATION DESCRIPTION

7-1. Outline of Air Conditioner Control

This is a fixed-capacity type of air conditioner with a Plasma Air-Purifier consisting of an AC fan motor for an indoor unit. Both Plasma Air-Purifier and AC motor drive circuit are mounted in the indoor unit. The electrical parts driving the compressor and the fan motor for an outdoor unit are mounted in the outdoor unit.

The air conditioner is controlled by the controller mounted in the indoor unit. The controller operates all components based on the commands transmitted from the remote control and the feedback data of the sensor is as follow:

- The temperature measurement at the air inlet of the indoor heat exchanger by the indoor temperature sensor
- □The temperature measurement at the indoor heat exchanger by the indoor heat exchanger temperature sensor
- Plasma Air-Purifier operation control
- Indoor fan motor operation control
- Louver motor control
- LED display control
- Outdoor fan motor operation control
- 4-WAYS-VALVE operation control
- Compressor operation control
- Receiving the information of the operation status and judging the information or the indication of errors

7-1-1. Louver control

- (1) Vertical air flow louver
Position of vertical air flow louver is automatically controlled according to the operation mode. Besides, position of vertical air flow louver can be arbitrarily set by pressing [FIX] button. The louver position which is set by [FIX] button is stored in the microcomputer, and the louver is automatically set at the stored position for the next operation.
- (2) Swing
If [SWING] button is pressed when the indoor unit is in operation, the vertical air flow louver starts swinging. When [FIX] button is pressed, it stops swinging.

7-1-2. Indoor fan control (AC Fan motor)

- (1) The indoor fan is operated by the stepless speed change AC motor.
- (2) For air flow level, speed of the indoor fan motor is controlled in five steps (LOW, LOW⁺, MED, MED⁺ and HIGH). If AUTO mode is selected, the fan motor speed is automatically controlled by the difference between the preset temperature and the room temperature.

$$LOW^+ = \frac{LOW + MED}{2}$$

$$MED^+ = \frac{MED + HIGH}{2}$$

Table 7-1-1

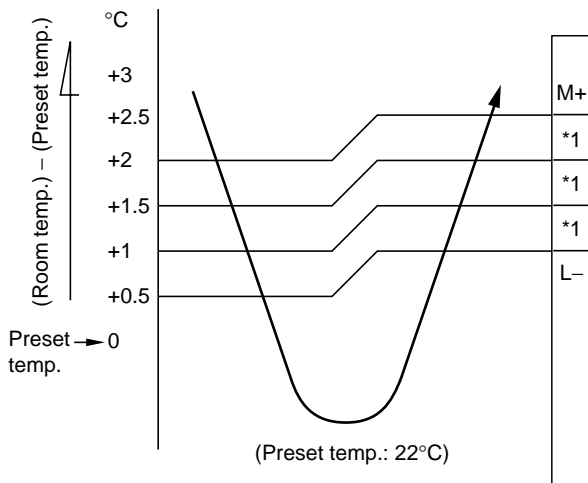
OPERATION MODE		FAN TAP														
		UH	H		M			L	L-	UL	SL					
Model	RAS-07NKD Series	Cooling			UH	H		M			L	L-	UL	SL		
		Fan only				H		M			L	L-				
		Dry						M			L	L-	UL		SL	
		Heat	UH	H				M		L	L-		UL			SL
		PAP only	UH	H				M			L	L-	UL	SL		
	RAS-07NKHD Series	rpm	1350	1300	1200	1050	1000	950	900	800	750	700			650	
		Air flow volume (m ³ /h)	650	630	570	490	460	430	400	340	310	280			250	
	RAS-10NKD Series	rpm	1350	1300	1250	1050	1000	950	900	800	750	700			650	
		Air flow volume (m ³ /h)	650	630	610	490	460	430	400	340	310	280			250	
	RAS-10NKHD Series	rpm	1300	1250	1200	1100	1000	900		800	750	700			650	
		Air flow volume (m ³ /h)	630	610	570	520	460	400		340	310	280			250	
	RAS-13NKD Series	rpm		1350	1300	1150	1100	1050	1000	950	900	850	800	750	700	
		Air flow volume (m ³ /h)		650	630	550	520	490	460	430	400	370	340	310	280	
	RAS-13NKHD Series	rpm		1350	1300	1150	1100	1050	1020	950	900	850	800	750	700	
Air flow volume (m ³ /h)			650	630	550	520	490	470	430	400	370	340	310	280		

7-2. Description of Operation Circuit

- (1) When turning on the breaker, the operation lamp blinks. This means that the power is on (or the power supply is cut off.)
- (2) When pressing [ϕ] button on the remote control, receiving beep sounds from the indoor unit, and the next operation is performed together with opening the vertical air flow louver.
- (3) Once the operation mode is set, it is memorized in the microcontroller so that the previous operation can be effected thereafter simply by pressing [ϕ] button.

7-2-1. Fan only operation (NKD Series only) ([MODE] button on the remote control is set to the fan only operation.)

- (1) When [FAN] button is set to AUTO, the indoor fan motor operates as shown in Fig. 7-2-1. When [FAN] button is set to LOW, LOW⁺, MED, MED⁺ or HIGH, the motor operates with a constant air flow.



NOTE :

*1: The values marked with *1 are calculated and controlled by the difference in motor speed between M+ and L-.

Fig. 7-2-1 Setting of air flow [FAN:AUTO]

- (2) The Hi POWER operation cannot be set.

7-2-2. Cooling operation ([MODE] button on the remote control is set to the cooling operation.)

- (1) The compressor, outdoor fan and operation display on the remote control are controlled as shown in Fig. 7-2-2.

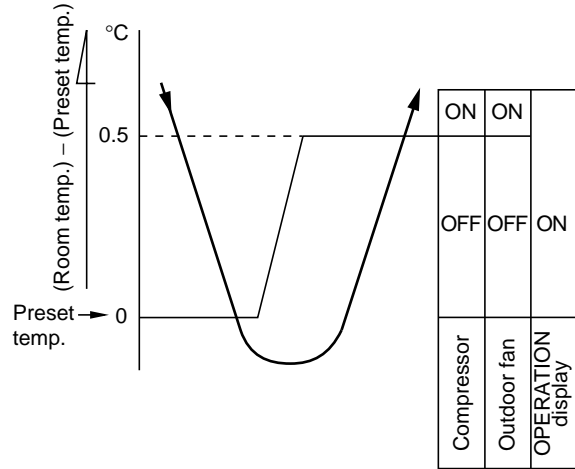
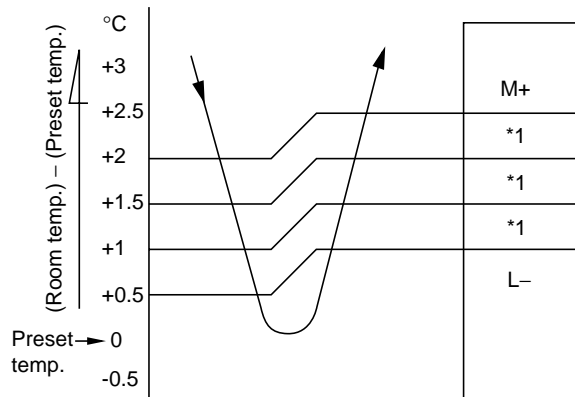


Fig. 7-2-2

- (2) When [FAN] button is set to AUTO, the indoor fan motor operates as shown in Fig. 7-2-3. When [FAN] button is set to LOW, LOW⁺, MED, MED⁺ or HIGH, the motor operates with a constant air flow.



NOTE :

*1: The values marked with *1 are calculated and controlled by the difference in motor speed between M+ and L-.

Fig. 7-2-3 Setting of air flow [FAN:AUTO]

7-2-3. Dry operation
 ([MODE] button on the remote control is set to the dry operation.)

- (1) The compressor, 4-way valve, outdoor fan and operation display on the remote control are controlled as shown in Fig. 7-2-4.

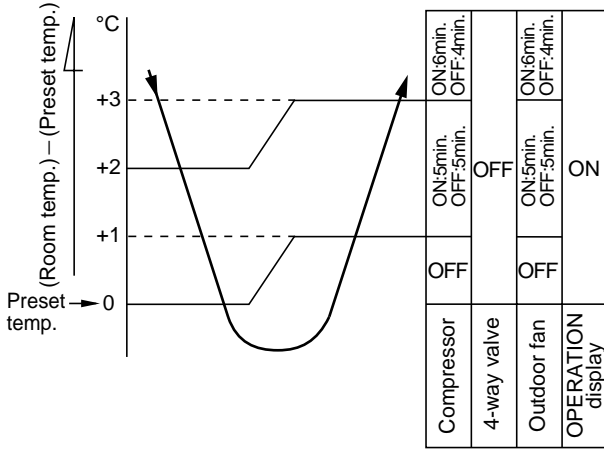


Fig. 7-2-4

- (2) The microcontroller turns the compressor on and off at the regular intervals (4 to 6 minutes). While the compressor is turning off, the indoor fan motor operates in the SUPER LOW position. The pattern of operation depending on the relation between room temperature and preset temperatures is shown in Fig. 7-2-5.

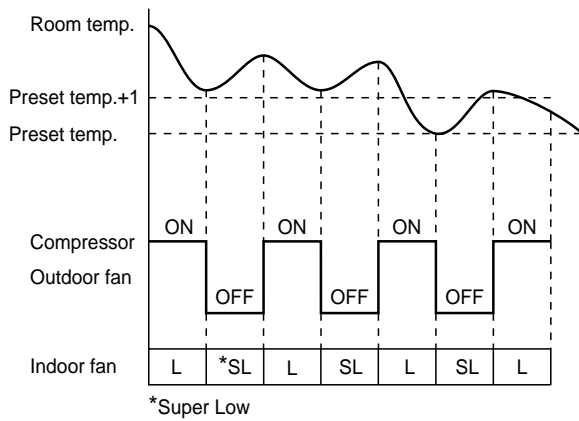


Fig. 7-2-5

- (3) [FAN] button on the remote control is set to AUTO only.
 (4) The Hi POWER operations cannot be set.

7-2-4. Heating operation (NKHD Series only)
 ([MODE] button on the remote control is set to the heating operation.)

- (1) The compressor, 4-way valve, outdoor fan and operation display on the remote control are controlled as shown in Fig. 7-2-6.

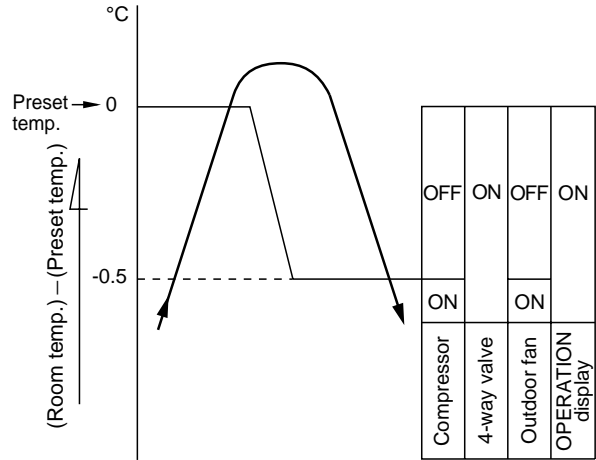
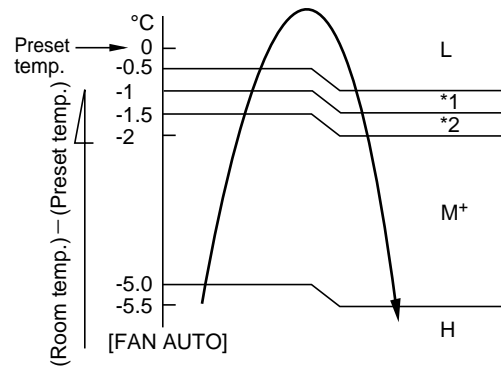


Fig. 7-2-6

- (2) When [FAN] button is set to AUTO, the indoor fan motor operates as shown in Fig. 7-2-7. When [FAN] button is set to LOW, LOW+, MED, MED+ or HIGH, the motor operates with a constant air flow.

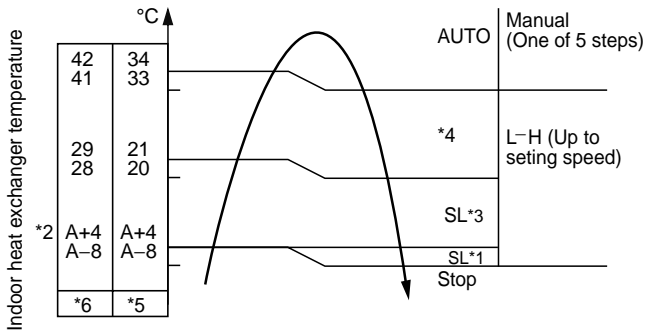


*1, *2 : The values marked with *1 and *2 are calculated and controlled by the difference in motor speed between M+ and L.

Fig. 7-2-7 Setting of air flow [FAN: AUTO]

- (3) The indoor heat exchanger restricts revolving speed of the fan motor to prevent a cold draft. The upper limit of the revolving speed is shown in Fig. 7-2-8 and Table 7-2-1.

RAS-13NKHD Series



**RAS-10NKHD Series
RAS-07NKHD Series**

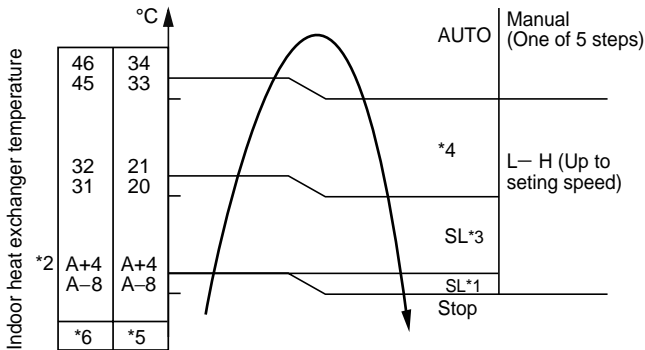


Fig. 7-2-7 Cold draft preventing control

NOTES :

- *1: The fan stops for 2 minutes after thermostat-OFF.
- *2: A is 24°C when the preset temperature is 24°C or more and A is the preset temperature when it is under 24 °C.
- *3: SL means Super Low.
- *4: Calculated from difference in motor speed between SL and H.
- *5 and *6:

Table 7-2-1

Fan speed	*5 Starting period	*6 Stabilized period
AUTO	<ul style="list-style-type: none"> • Up until 12 minutes passed after starting the unit • From 12 to 25 minutes passed after starting the unit and room temperature is 3°C lower than preset temperature • temperature 	<ul style="list-style-type: none"> • From 12 to 25 minutes passed after starting the unit and room temperature is between preset temperature and 3°C lower than preset temperature • 25 minutes or more passed after starting the unit
Manual (L – H)	<ul style="list-style-type: none"> • Room temperature < Preset temperature – 4°C 	<ul style="list-style-type: none"> • Room temperature ≥ Preset temperature – 3.5°C

7-2-5. Automatic operation

([MODE] button on the remote control is set to the automatic operation.)

- (1) One of 3 operations (Cooling, Fan only or Heating) is selected according to difference between the preset temperature and the room temperature at which the automatic operation has started, as shown in Fig. 7-2-9. The Fan only operation continues until the room temperature reaches a level at which another mode is selected.
- (2) Temporary Auto
When the [RESET] button on the indoor unit is pushed, the preset temperature is fixed at 24 °C and the indoor unit is controlled as shown in Fig. 7-2-9.

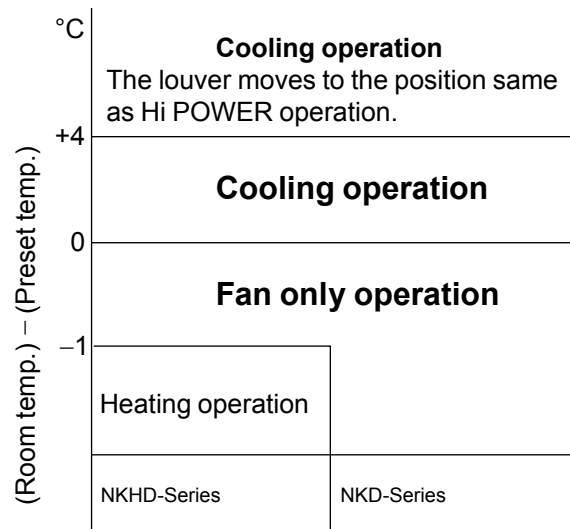

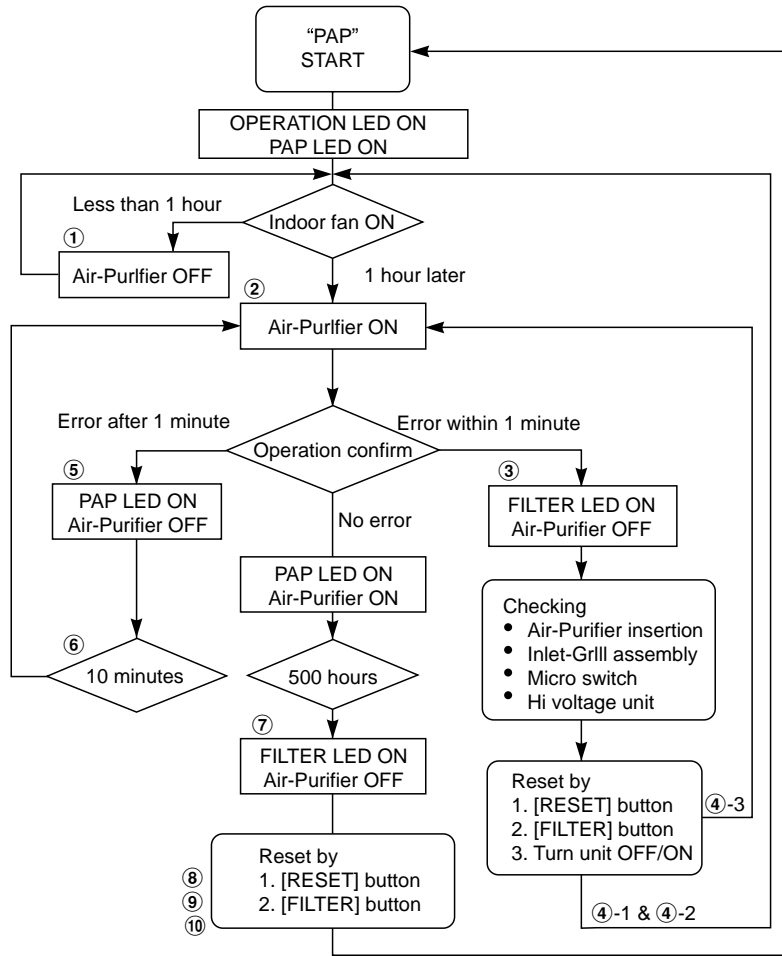


Fig. 7-2-9

7-2-6. Plasma Air-Purifier (PAP) operation.

Plasma Air-Purifier is able to operate together with other operations mode of air conditioner by pressing [PAP] button to turn ON/OFF the Plasma Air-Purifier while other mode is on operation. Plasma Air-Purifier is able to operate individual by pressing [PAP] button to turn ON/OFF instead of pressing [ϕ] button. For pressing the [ϕ] button is able to turn both air conditioner and Plasma Air-Purifier ON/OFF at the same time. (depends on presetting before turning off.) When [PAP] button is pressed,  mark is indicated on the display of the remote control and the Plasma Air-Purifier operates as follows.

(1) Operation flow chat.



Case	Descriptions
①&②	In case of the first operation, after circuit breaker turns OFF/ON or after reset by case No. ④-1, ④-2, ⑧ and ⑨. The Air-Purifier will operates after 1 hour.
	For daily used, without turning OFF circuit breaker, Air-Purifier operates immediately.
	By using short timer function of remote control*, Air-Purifier operates immediately.
③	In case of some error occurs within 1 minute, the above items need to be checked.
④-1	Case no ③, reset by [RESET] button on the indoor unit. Then Air-Purifier will operate again after 1 hour.
④-2	Case no ③, reset by [FILTER] button on the remote control. Then Air-Purifier will operate again after 1 hour.
④-3	Case no ③, reset by turning OFF the unit and turning ON again. Then Air-Purifier operates immediately.
⑤	In case of some error occurs after 1 minute. Air-Purifier will turn OFF but in contrast, PAP LED will keep turning ON continuously.
⑥	Case no ⑤, the Air-Purifier will operate again after 10 minute.
⑦	After complete 500 hours operation, FILTER LED will turn ON and Air-Purifier will turn OFF. In addition, Air-Purifier should be cleaned.
⑧	Case no ⑦, reset by [RESET] button on the indoor unit, and Air-Purifier will operate again after 1 hour.
⑨	Case no ⑦, reset by [FILTER] button on the remote control, and Air-Purifier will operate again after 1 hour.
⑩	Case no ⑦, can not reset by turning unit OFF and ON.

* Short timer is the function of the remote control that activates the setting for the sudden operation. This function can be set as shown below.

1. Press [⏻] button to turn the unit OFF.
2. Use the tip of the pencil to push the [CHECK] button and hold, "00" will show on display, then press [SET] button to make "00" disappear.
3. Press [⏻] button again to turn the unit ON.
4. When short timer is activated, all setting on the remote operates immediately, Besides, all LED turns ON continuously for 2 seconds.

(2) The indoor fan motor and Plasma Air-Purifier operation.

- When Plasma Air-Purifier has been operated with other operation of air conditioner mode (Fan only, AUTO, Cooling, Dry or Heat). The speed revolution of indoor fan is based upon the operated mode of air conditioner. In fact, Plasma Air-Purifier works continuously.
- When the Plasma Air-Purifier is activated individually and the fan speed is set to LOW, LOW+, MED, MED+, or HIGH, the speed revolution of the indoor fan will be constant. In fact, Plasma Air-Purifier works continuously.

Moreover, when the Plasma Air-Purifier is activated individually and the fan speed is set to AUTO, the speed revolution of the indoor fan and the operation of Plasma Air-Purifier is shown as the fig. 7-2-10

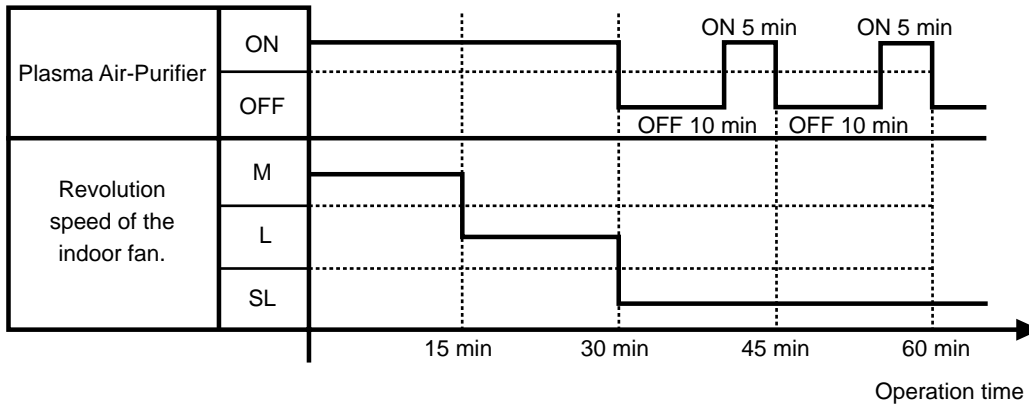


Fig. 7-2-10

7-3. Hi POWER Mode ([Hi POWER] button on the remote control is pressed.)

When [Hi POWER] button is pressed while the indoor unit is in Auto, Cooling or Heating operation, Hi POWER mark is indicated on the display of the remote control and the unit operates as follows.

- (1) Automatic operation
 - The indoor unit operates in according to the current operation.
- (2) Cooling operation
 - The setting temperature drops 3°C.
(The value of the setting temperature on the remote control does not change.)
 - If the room temperature is higher than the setting temperature by 3.5°C or more, the horizontal louver moves to the Hi POWER position automatically. Then when the room temperature is 1°C less than the setting temperature the horizontal louver returns automatically.
 - FAN speed : [AUTO]
If the room temperature is higher than the setting temperature by 3.5°C or more, the air conditioner operates at maximum airflow level. If the room temperature is higher than the setting temperature by less than 3.5°C, the air conditioner operates at normal airflow level.
 - FAN speed : One of 5 levels
If the room temperature is higher than the setting temperature by 3.5°C or more, the air conditioner operates at higher consecutive airflow level. If the room temperature is higher than the setting temperature by less than 3.5°C, the air conditioner operates at normal airflow level.
- (3) Heating operation (NKHD Series only)
 - The preset temperature increases 2°C,
(The value of the preset temperature on the remote control does not change.)
 - The indoor unit operates in normal heating mode except the preset temperature is higher (+2°C).
- (4) The Hi POWER mode can not be set in Dry or Fan only operation.

7-4. High-Temperature Limit Control (NKHD Series only)

The microcontroller detects the indoor heat exchanger temperature to prevent pressure of a refrigerating cycle from increasing excessively. The compressor and outdoor fan motor are controlled as shown in Fig. 7-4-1.

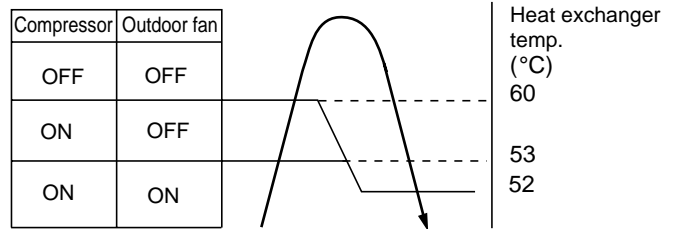


Fig. 7-4-1

7-5. Low-Temperature Limit Control

The microcontroller detects the indoor heat exchanger temperature to prevent the indoor heat exchanger from freezing. The compressor and outdoor fan motor are controlled as shown in Fig. 7-5-1 and 7-5-2.

RAS-13NKHD Series RAS-13NKD Series

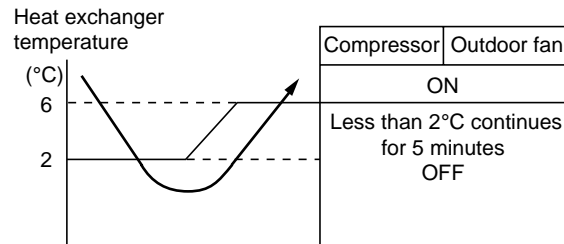


Fig. 7-5-1

RAS-10NKHD Series, RAS-07NKHD Series RAS-10NKD Series, RAS-07NKD Series

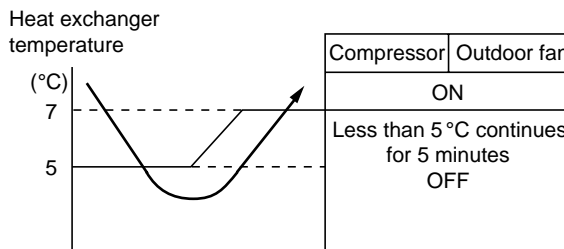


Fig. 7-5-2

7-6. Defrost Operation (NKHD Series only)

During the heating operation, the outdoor heat exchanger temperature goes down and sometimes it is frozen.

In this case, the air conditioner stops the heating operation and starts the defrost operation to melt ice.

7-6-1. Condition to start the defrost operation

The defrost operation starts whichever below conditions are satisfied.

- (1) When the cumulative compressor operating time is longer than 40 or 90 minutes and difference between the indoor heat exchanger temperature and the room temperature is less than the specified value. (This value is decided by the microprocessor.) (Control example is shown in Fig. 7-6-1. In case of B or C, the defrost operation starts.)
- (2) When the current limit control or the high temperature limit control is performed for total of 90 minutes.

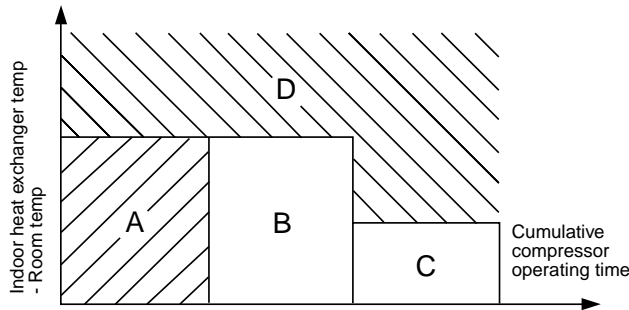


Fig. 7-6-1 (Indoor fan speed : M)

7-6-2. Defrost operation time control

<In case of B>

- (1) The heating operation is performed for at least 40 minutes.
- (2) The maximum defrost operating time is 6 minutes. The defrost operating time for the 4th cycle is 10 minutes. (When the outdoor temperature is very low, however, the defrost operating time is 10 minutes.)

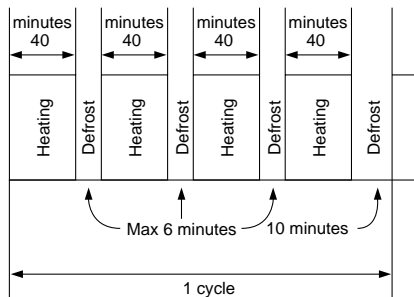


Fig. 7-6-2

<In case of C>

- (1) The heating operation is performed for at least 90 minutes.
- (2) The defrost operating time is 10 minutes.

7-6-3. Ending condition at defrost operation

- (1) When the compressor current becomes 7.5A or more during defrost operation, the defrost operation stops and the heating operation restarts. (The current sensor detects the compressor current.)
- (2) The defrost operation continues for at most 6 minutes or 10 minutes.

7-7. Current Limit Control (NKHD Series only)

The microcontroller detects the input current so as to prevent it exceeds a specified value by means of controlling the outdoor fan control as described in (1) and (2).

(1) Current limit control (Cooling operation)

Control is performed as shown below by detecting the compressor operating current with a current sensor (C.T).

RAS-13NKHD Series / RAS-10NKHD Series, RAS-07NKHD Series

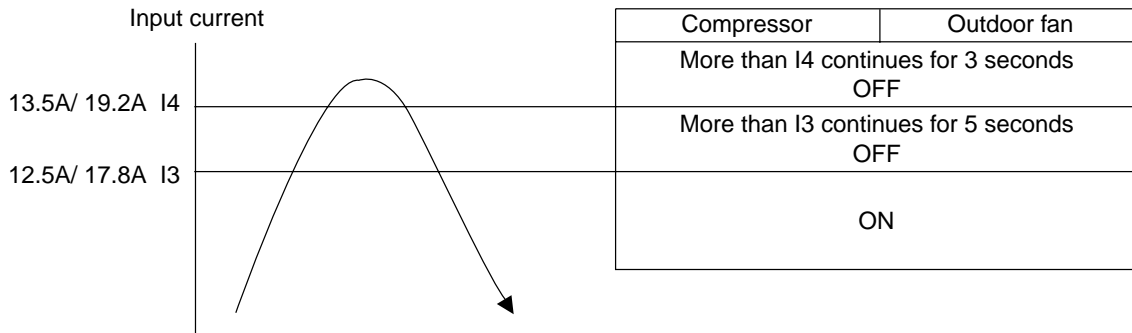


Fig. 7-7-1

(2) Current limit control (Heating operation)

Control is performed as shown in Fig. 7-7-2

RAS-13NKHD Series / RAS-10NKHD Series, RAS-07NKHD Series

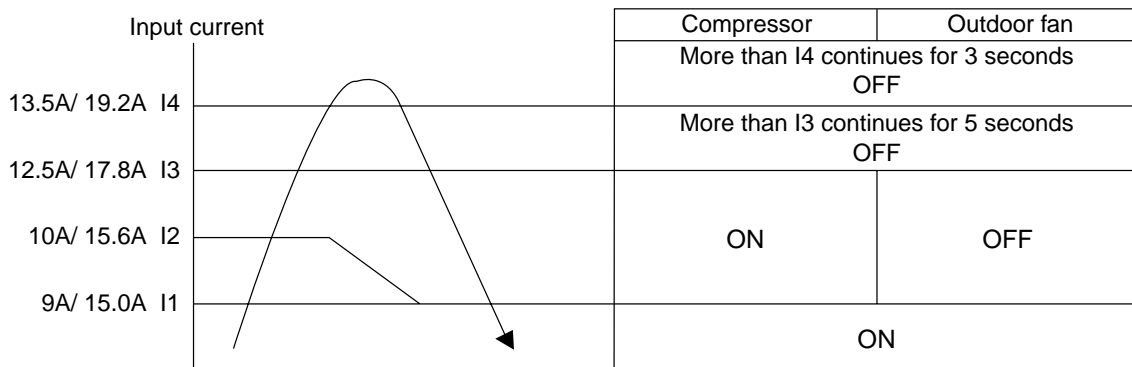


Fig. 7-7-2

Remark :

This function is available only for heat pump model (Cooling models have no a current sensor (C.T)).

7-8. Auto Restart Function

The indoor unit is equipped with an automatic restarting function which allows the unit to restart operating with the set operating conditions in the event of power supply being accidentally shut down. The operation will resume without warning three minutes after power is restored.

This function is not set to work when shipped from the factory. Therefore it is necessary to set it to work.

7-8-1. How to set auto restart function

To set the auto restart function, proceed as follows:

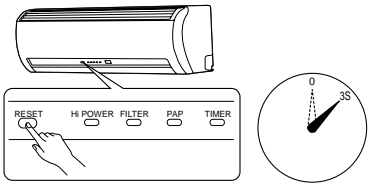
The power supply to the unit must be on; the function will not set if the power is off.

Push the [RESET] button located in the center of the front panel continuously for three seconds.

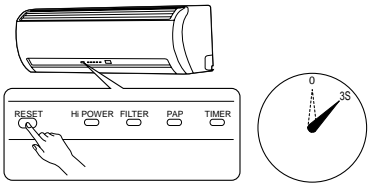
The unit receives the signal and beeps three times.

The unit then restarts operating automatically in the event of power supply being accidentally shut down.

When the unit is on standby (Not operating)

Operation	Motions
<p>Push [RESET] button for more than three seconds.</p> 	<p>The unit is on standby.</p> <p style="text-align: center;">↓</p> <p>The unit starts to operate. The green lamp is on.</p> <p style="text-align: center;">↓ After approx. three seconds,</p> <p>The unit beeps three times and continues to operate. The lamp changes from green to orange.</p> <p>If the unit is not required to operate at this time, push [RESET] button once more or use the remote control to turn it off.</p>

When the unit is in operation

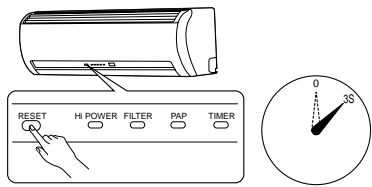
Operation	Motions
<p>Push [RESET] button for more than three seconds.</p> 	<p>The unit is in operation. The green lamp is on.</p> <p style="text-align: center;">↓</p> <p>The unit stops operating. The green lamp is turned off.</p> <p style="text-align: center;">↓ After approx. three seconds,</p> <p>The unit beeps three times.</p> <p>If the unit is required to operate at this time, push [RESET] button once more or use the remote control to turn it on.</p>

- While this function is being set, if the unit is in operation, the orange lamp is on.
- This function can not be set if the timer operation has been selected.
- When the unit is turned on by this function, the louver will not swing even though it was swinging automatically before shutting down.
- While the filter check lamp is on, the [RESET] button has the function of filter reset button.

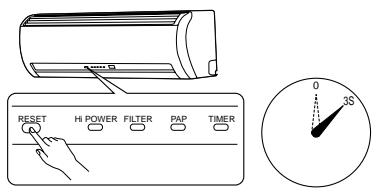
7-8-2. How to cancel auto restart function

To cancel auto restart function, proceed as follows:
 Repeat the setting procedure: the unit receives the signal and beeps three times.
 The unit will be required to be turned on with the remote control after the main power supply is turned off.

When the unit is on standby (Not operating)

Operation	Motions
<p>Push [RESET] button for more than three seconds.</p> 	<p>The unit is on standby.</p> <p>↓</p> <p>The unit starts to operate. The orange lamp is on.</p> <p>↓ After approx. three seconds,</p> <p>The unit beeps three times and continues to operate. The lamp changes from orange to green.</p> <p>If the unit is not required to operate at this time, push [RESET] button once more or use the remote control to turn it off.</p>

When the unit is in operation

Operation	Motions
<p>Push [RESET] button for more than three seconds.</p> 	<p>The unit is in operation. The orange lamp is on.</p> <p>↓</p> <p>The unit stops operating. The orange lamp is turned off.</p> <p>↓ After approx. three seconds,</p> <p>The unit beeps three times.</p> <p>If the unit is required to operate at this time, push [RESET] button once more or use the remote control to turn it on.</p>

- While this function is being set, if the unit is in operation, the orange lamp is on.

7-8-3. Power failure during timer operation

When the unit is in Timer operation, if it is turned off because of power failure, the timer operation is cancelled. Therefore, set the timer operation again.

7-9. Filter Check Lamp

When the operation time of Plasma Air-Purifier reaches 500 hours, the filter check lamp indicates. After cleaning the Plasma Air-Purifier, turn off the filter check lamp.

7-9-1. How to turn off filter check lamp

Press [FILTER] button on the remote control.
 OR push [RESET] button on the indoor unit.

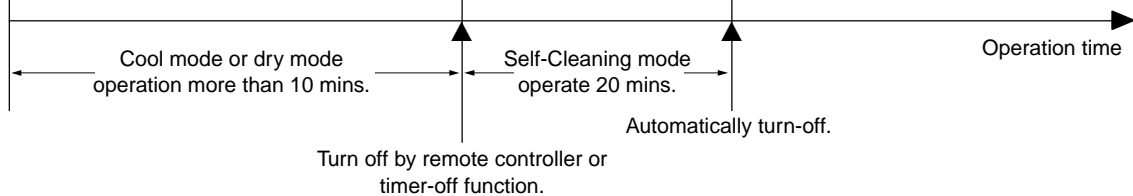
Note :

If [RESET] button is pushed while the filter check lamp is not indicating, the indoor unit will start the Automatic Operation.

7-10. Self-Cleaning function

Self-Cleaning function is designed to reduce humidity that causes mold to form inside the air conditioning unit. This advanced, efficient system reduces moisture in the coil. When air conditioner is turned off, the internal fan activates and dries the moisture in the coil for 20 minutes, then it turns off automatically.

Operation display	ON	OFF	OFF
FCU fan	ON rpm is depend on presetting.	ON rpm is SUPER LOW speed.	OFF
FCU louver	OPEN	CLOSE	CLOSE
Timer display	ON or OFF depend on presetting of timer function.	ON	ON or OFF depend on presetting of timer function.
Compressor	ON or OFF depend on presetting per room temperature.	OFF	OFF
CDU fan	ON or OFF depend on presetting per room temperature.	OFF	OFF



- The Self-Cleaning function is set as default at ex-factory.
- Self-Cleaning operation can stop manually by press [⏻] button of the remote control one more time.

7-10-1. How to cancel Self-Cleaning function

To cancel the Self-Cleaning function, proceed as follows:

- Press [RESET] button one time or use remote control to turn on air conditioner. The OPERATION display will show in orange color (When AUTO-RESTART is ON) or green color (When AUTO-RESTART is OFF).
- Hold down the [RESET] button for more than 20 seconds. (The air conditioner will stop suddenly when the [RESET] is pressed but keep holding it continue. The will beep 3 times in the first 3 seconds but it is not related to Self-Cleaning function)
- After holding about 20 seconds, the air conditioner will beep 5 times without any blinking of display.
- The Self-Cleaning Operation had been cancelled.

Remarks

- Per setting of Self-Cleaning function above, AUTO-RESTART function had been cancelled. To set AUTO-RESTART again, please follow item 7-8-1.

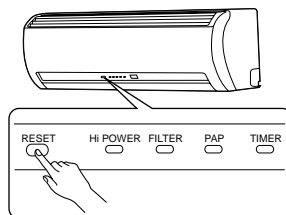
7-10-2. How to set Self-Cleaning function.

To set the Self-Cleaning function, proceed as follows.

- Press [RESET] button one time or use remote control to turn on air conditioner. The OPERATION display will show in orange color (When AUTO-RESET is ON) or green color (When AUTO-RESTART is OFF).
- Hold down the [RESET] button for more than 20 seconds. (The air conditioner will stop suddenly when the [RESET] is pressed but keep holding it continue. Then will beep 3 times in the first 3 seconds but it is not related to Self-Cleaning function)
- After holding about 20 seconds, the air conditioner will beep 5 times and OPERATION display blinks 5 times.
- The Self-Cleaning function had been set.

Remarks

- Per setting of Self-Cleaning function above, AUTO-RESTART function had been cancelled. To set AUTO-RESTART again, please follow item 7-8-1.



8. INSTALLATION PROCEDURE

8-1. Safety Cautions

For general public use

Power supply cord of parts of appliance for Indoor use shall be at least polychloroprene sheathed flexible cord (design H07 RN-F), or cord designation 245 IEC66.

CAUTION

To Disconnect the Appliance from the Main Power Supply

This appliance must be connected to the main power supply by means of a circuit breaker or a switch with a contact separation of at least 3 mm.

If this is not possible, a power supply plug with earth must be used. This plug must be easily accessible after installation. The plug must be disconnected from the power supply socket in order to disconnect the appliance completely from the mains.

DANGER

- FOR USE BY QUALIFIED PERSONS ONLY.
- TURN OFF MAIN POWER SUPPLY BEFORE ATTEMPTING ANY ELECTRICAL WORK. MAKE SURE ALL POWER SWITCHES ARE OFF. FAILURE TO DO SO MAY CAUSE ELECTRIC SHOCK.
- CONNECT THE CONNECTING CABLE CORRECTLY. IF THE CONNECTING CABLE IS CONNECTED WRONGLY, ELECTRIC PARTS MAY BE DAMAGED.
- CHECK THE EARTH WIRE THAT IT IS NOT BROKEN OR DISCONNECTED BEFORE INSTALLATION.
- DO NOT INSTALL NEAR CONCENTRATIONS OF COMBUSTIBLE GAS OR GAS VAPORS. FAILURE TO FOLLOW THIS INSTRUCTION CAN RESULT IN FIRE OR EXPLOSION.
- TO PREVENT OVERHEATING THE INDOOR UNIT AND CAUSING A FIRE HAZARD, PLACE THE UNIT WELL AWAY (MORE THAN 2 M) FROM HEAT SOURCES SUCH AS RADIATORS, HEATERS, FURNACE, STOVES, ETC.
- WHEN MOVING THE AIR-CONDITIONER FOR INSTALLING IT IN ANOTHER PLACE AGAIN, BE VERY CAREFUL NOT TO GET THE SPECIFIED REFRIGERANT WITH ANY OTHER GASEOUS BODY INTO THE REFRIGERATION CYCLE. IF AIR OR ANY OTHER GAS IS MIXED IN THE REFRIGERANT, THE GAS PRESSURE IN THE REFRIGERATION CYCLE BECOMES ABNORMALLY HIGH AND IT RESULTINGLY CAUSES BURST OF THE PIPE AND INJURIES ON PERSONS.
- IN THE EVENT THAT THE REFRIGERANT GAS LEAKS OUT OF THE PIPE DURING THE INSTALLATION WORK, IMMEDIATELY LET FRESH AIR INTO THE ROOM. IF THE REFRIGERANT GAS IS HEATED BY FIRE OR SOMETHING ELSE, IT CAUSES GENERATION OF POISONOUS GAS.

WARNING

- Never modify this unit by removing any of the safety guards or bypassing any of the safety interlock switches.
- Do not install in a place which cannot bear the weight of the unit.
Personal injury and property damage can result if the unit falls.
- Before doing the electrical work, attach an approved plug to the power supply cord.
Also, make sure the equipment is properly earthed.
- Appliance shall be installed in accordance with national wiring regulations.
If you detect any damage, do not install the unit. Contact your TOSHIBA dealer immediately.

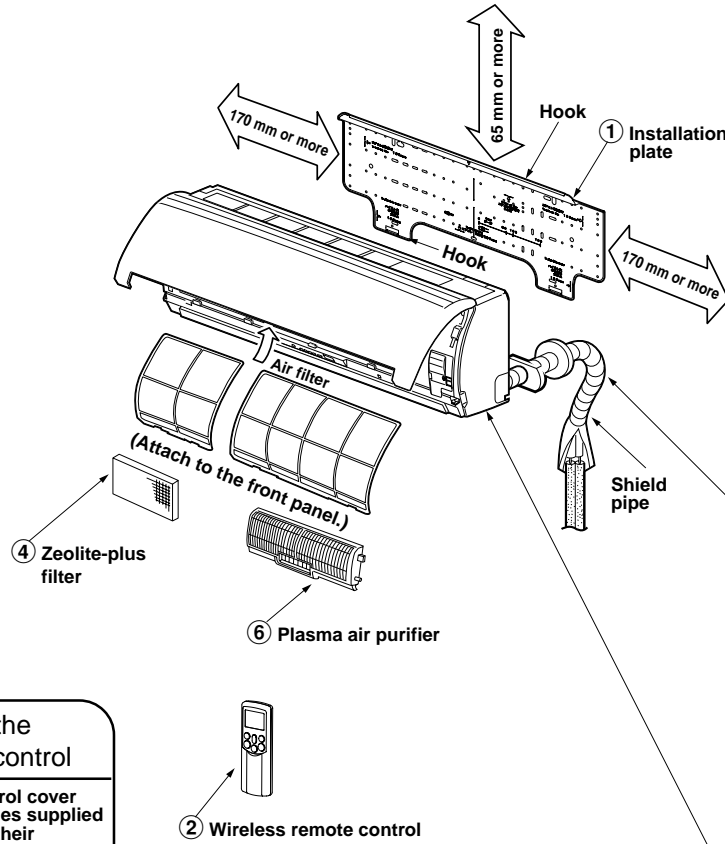
CAUTION

- Exposure of unit to water or other moisture before installation could result in electric shock.
Do not store it in a wet basement or expose to rain or water.
- After unpacking the unit, examine it carefully for possible damage.
- Do not install in a place that can increase the vibration of the unit. Do not install in a place that can amplify the noise level of the unit or where noise and discharged air might disturb neighbors.
- To avoid personal injury, be careful when handling parts with sharp edges.
- Please read this installation manual carefully before installing the unit. It contains further important instructions for proper installation.

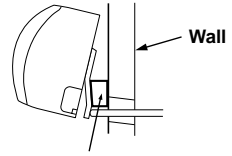
REQUIREMENT OF REPORT TO THE LOCAL POWER SUPPLIER

Please make absolutely sure that the installation of this appliance is reported to the local power supplier before installation. If you experience any problems, or if the installation is not accepted by the supplier, the service agency will take adequate countermeasures.

8-2. Installation Diagram of Indoor and Outdoor Units

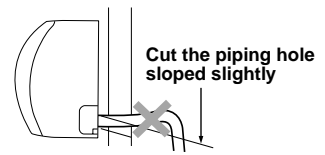


For the rear left and left piping



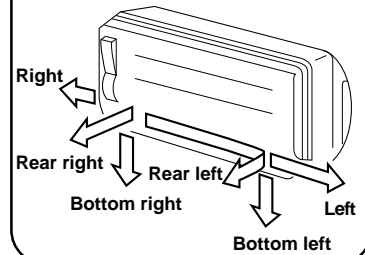
Insert the cushion between the indoor unit and wall, and tilt the indoor unit for better operation.

Do not allow the drain hose to get slack.

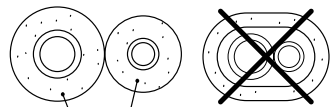


Make sure to run the drain hose sloped downward.

The auxiliary piping can be connected the left, rear left, rear right, right, bottom right or bottom left.



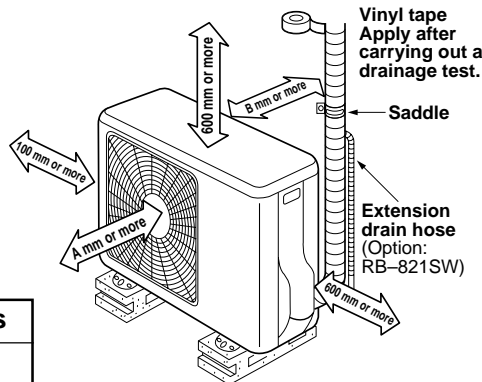
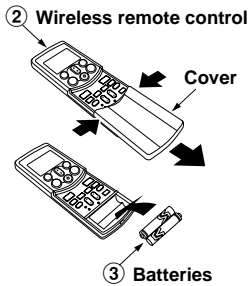
Insulate the refrigerant pipes separately with insulation, not together.



6 mm thick heat resisting polyethylene foam

Before installing the wireless remote control

- With the remote control cover open, load the batteries supplied correctly, observing their polarity.



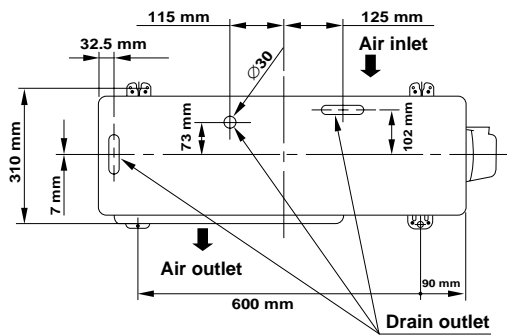
	13 series	07, 10 series
A	600 mm	400 mm
B	100 mm	45 mm

8-3. Installation

8-3-1. Optional installation parts

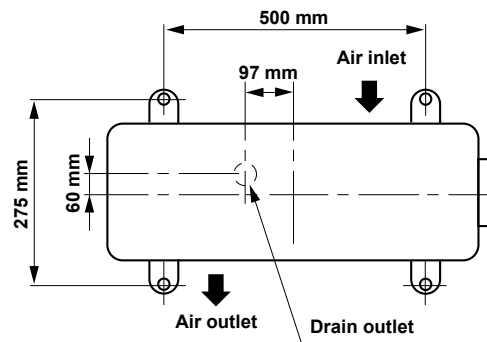
Part Code	Parts name	Q'ty
Ⓐ	Refrigerant piping Liquid side : $\varnothing 6.35$ mm Gas side : $\varnothing 9.52$ mm (07, 10 series) Gas side : $\varnothing 12.70$ mm (13 series)	One each
Ⓑ	Pipe insulating material (polyethylene foam, 6 mm thick)	1
Ⓒ	Putty, PVC tapes	One each

<Fixing bolt arrangement of outdoor unit>



RAS-10, 13 Series

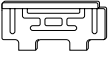





Fig. 8-3-1



RAS-07 Series

- Secure the outdoor unit with fixing bolts and nuts if the unit is likely to be exposed to a strong wind.
- Use $\varnothing 8$ mm or $\varnothing 10$ mm anchor bolts and nuts.

8-3-2. Accessory and installation parts

Part No.	Part name (Q'ty)	Part No.	Part name (Q'ty)	Part No.	Part name (Q'ty)
①	 Installation plate x 1	③	 Battery x 2	⑤	 Mounting screw $\varnothing 4 \times 25 \ell \times 6$
②	 Wireless remote control x 1	④	 Zeolite-plus filter x 1	⑥	 Plasma air purifier x 1

Others

Name
Owner's manual
Installation manual

This model is not equipped with an extension drain hose.

Option :

For the extension drain hose, use an optionally available RB-821SW or commercially available one.

8-4. Indoor Unit

8-4-1. Installation place

- A place which provides the spaces around the indoor unit as shown in the above diagram.
- A place where there is no obstacle near the air inlet and outlet.
- A place that allows easy installation of the piping to the outdoor unit.
- A place which allows the front panel to be opened.

CAUTION

- Direct sunlight to the indoor unit's wireless receiver should be avoided.
- The microprocessor in the indoor unit should not be too close to RF noise sources.
(For details, see the owner's manual.)

<Remote control>

- A place where there are no obstacles such as a curtain that may block the signal from the indoor unit.
- Do not install the remote control in a place exposed to direct sunlight or close to a heating source, such as a stove.
- Keep the remote control at least 1 m apart from the nearest TV set or stereo equipment. (This is necessary to prevent image disturbances or noise interference.)
- The location of the remote control should be determined as shown below.

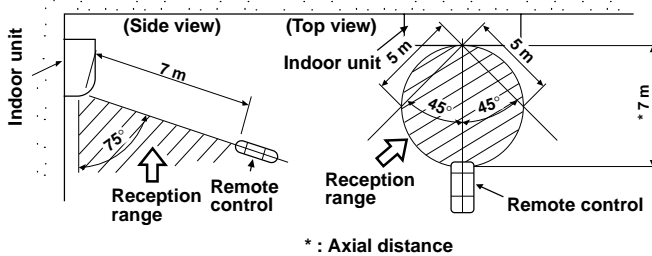


Fig. 8-4-1

8-4-2. Cutting a hole and mounting installation plate

<Cutting a hole>

When installing the refrigerant pipes from the rear.

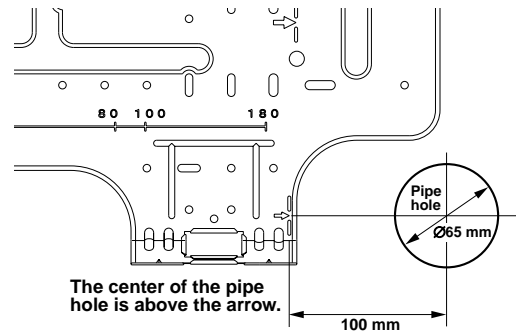


Fig. 8-4-2

1. After determining the pipe hole position on the mounting plate (➔), drill the pipe hole (Ø65 mm) at a slight downward slant to the outdoor side.

NOTE

- When drilling a wall that contains a metal lath, wire lath or metal plate, be sure to use a pipe hole brim ring sold separately.

<Mounting the installation plate>

For installation of the indoor unit, use the paper pattern on the back.

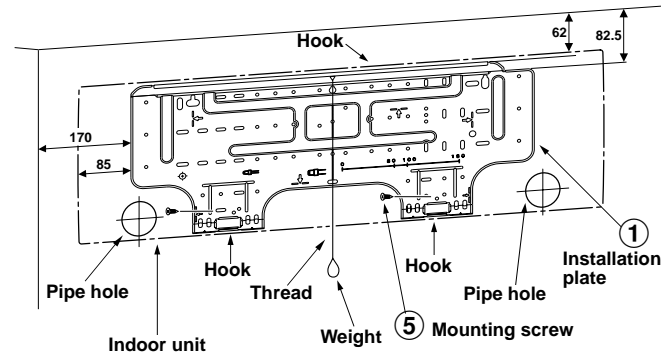


Fig. 8-4-3

<When the installation plate is directly mounted on the wall>

1. Securely fit the installation plate onto the wall by screwing it in the upper and lower parts to hook up the indoor unit.
2. To mount the installation plate on a concrete wall with anchor bolts, utilize the anchor bolt holes as illustrated in the above figure.
3. Install the installation plate horizontally in the wall.

CAUTION

When installing the installation plate with a mounting screw, do not use the anchor bolt hole. Otherwise the unit may fall down and result in personal injury and property damage.

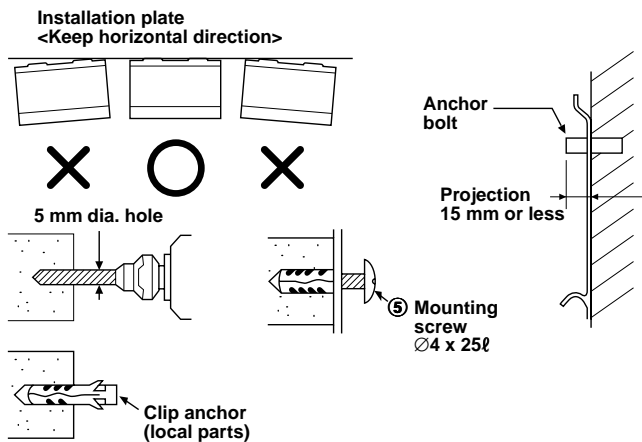


Fig. 8-4-4

CAUTION

Failure to firmly install the unit may result in personal injury and property damage if the unit falls.

- In case of block, brick, concrete or similar type walls, make 5 mm dia. holes in the wall.
- Insert clip anchors for appropriate mounting screws ⑤.

NOTE

- Secure four corners and lower parts of the installation plate with 4 to 6 mounting screws to install it.

8-4-3. Electrical work

1. The supply voltage must be the same as the rated voltage of the air conditioner.
2. Prepare the power source for exclusive use with the air conditioner.

CAUTION

- This appliance can be connected to the mains in either of the following two ways.
 - (1) Connection to fixed wiring:
A switch or circuit breaker which disconnects all poles and has a contact separation of at least 3 mm must be incorporate in the fixed wiring. An approved circuit breaker or switches must used.
 - (2) Connection with power supply plug:
Attach power supply plug with power cord and plug it into wall outlet. An approved power supply cord and plug must be used.

NOTE

- Ensure all wiring is used within its electrical rating.

Model	RAS-10NKHD-E RAS-10NKD-E RAS-07NKD-E	RAS-13NKHD-E RAS-13NKD-E
Power source	50Hz, 220 – 240 V Single phase	
Maximum running current	7.5A	12A
Plug socket & fuse rating	16A	
Power cord	1 mm ² or more	1.3 mm ² or more

8-4-4. Wiring connection

<How to connect the power cord>

For the air conditioner that does not have power cord, connect a power cord to it as mentioned below.

- (1) Open the air inlet grille upward.
- (2) Remove the four screws securing the front panel.
- (3) Slightly open the lower part of the front panel then pull the upper part of the front panel toward you to remove it from the rear plate.
- (4) After removing the front panel, remove the power cord connect cover and the cord camp.
- (5) Connect and secure the power supply cord and secure the cord camp and the power connect cover.
- (6) Put the power supply cord through the notch.
- (7) Be sure to smooth the notch with a file, etc.

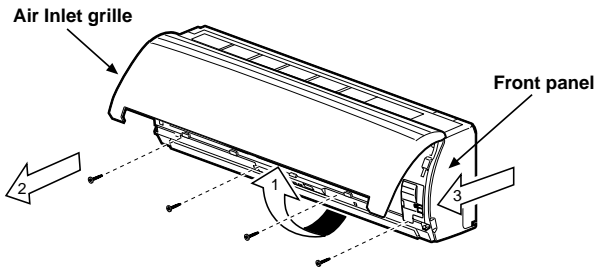


Fig. 8-4-5

<Stripping length of the power cord>

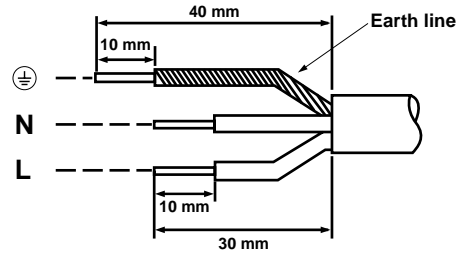


Fig. 8-4-6

NOTE

- Use stranded wire only.
- Wire type : More than 1.5 mm² (H07RN-F or 245 IEC66) or 1.3 mm² (AWG-16)

<Taking out the power cord>

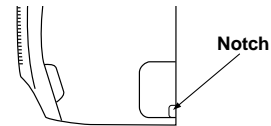


Fig. 8-4-7

Put the power supply cord through the notch.

<How to connect the connecting cable>

Wiring of the connecting cable can be carried out without removing the front panel.

1. Remove the air inlet grille.
Open the air inlet grille upward and pull it toward you.
2. Remove the terminal cover and cord clamp.
3. Insert the connecting cable (according to the local cords) into the pipe hole on the wall.
4. Take out the connecting cable through the cable slot on the rear panel so that it protrudes about 15 cm from the front.
5. Insert the connecting cable fully into the terminal block and secure it tightly with screws.
6. Tightening torque : 1.2 N·m (0.12 kgf·m)
7. Secure the connecting cable with the cord clamp.
8. Fix the terminal cover, rear plate bushing and air inlet grille on the indoor unit.

For RAS-07,10,13NKD-E

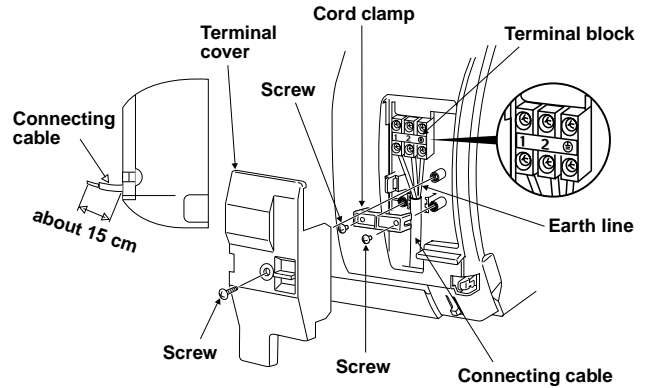
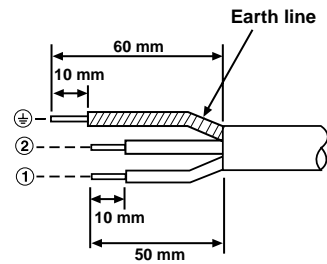


Fig. 8-4-10



Stripping length of the connecting cable

Fig. 8-4-11

CAUTION

- Be sure to refer to the wiring system diagram labeled inside the front panel.
- Check local electrical cords and also any specific wiring instructions or limitations.

For RAS-07,10,13NKHD-E

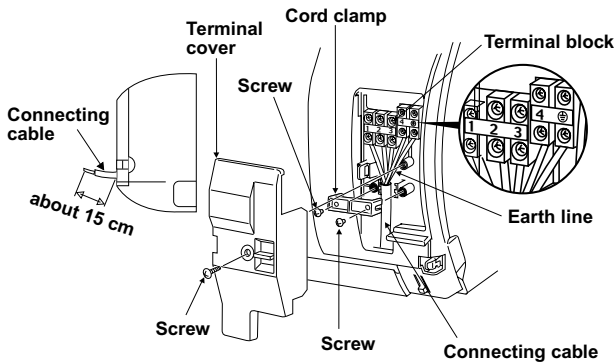
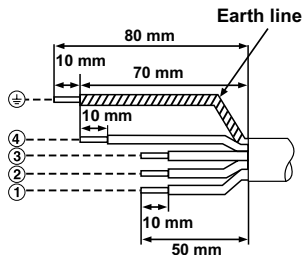


Fig. 8-4-8



Stripping length of the connecting cable

Fig. 8-4-9

NOTE

- Use stranded wire only.
- Wire type : H07RN-F or 245 IEC66 (More than 2.0 mm²)

<How to install the air inlet grille on the indoor unit>

- When attaching the air inlet grille, the contrary of the removed operation is performed.

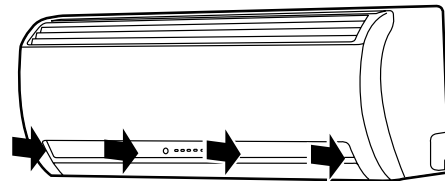
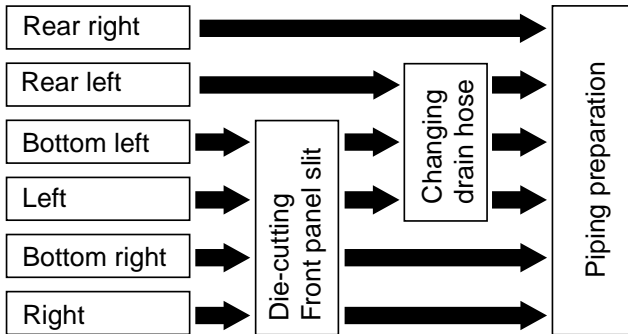


Fig. 8-4-12

8-4-5. Piping and drain hose installation

<Piping and drain hose forming>

* Since dewing results in a machine trouble, make sure to insulate both the connecting pipes. (Use polyethylene foam as insulating material.)



1. Die-cutting Front panel slit

For leftward connection, cut out slit on the left side of the front panel. (A knife will produce splinters, so use nippers.)

2. Changing drain hose

For leftward connection, bottom leftward connection and rear leftward connection's piping, it is necessary to change the drain hose and drain cap.

How to remove the drains cap

Clip drain cap by needle-nose plier, and pull out.

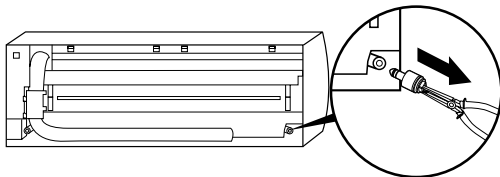


Fig. 8-4-13

How to install the drain hose

Firmly insert drain hose connecting part until hitting on a heat insulator.

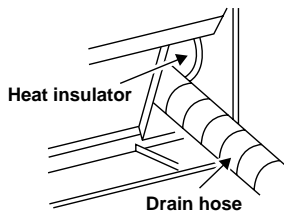


Fig. 8-4-14

How to fix the drains cap

1) Insert hexagonal wrench (4 mm) in a center head.

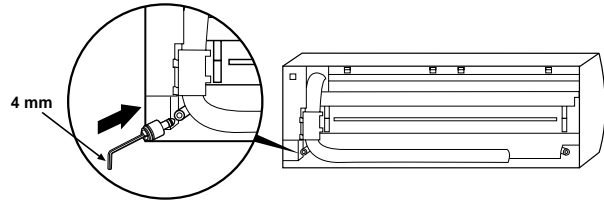


Fig. 8-4-15

2) Firmly insert drains cap.

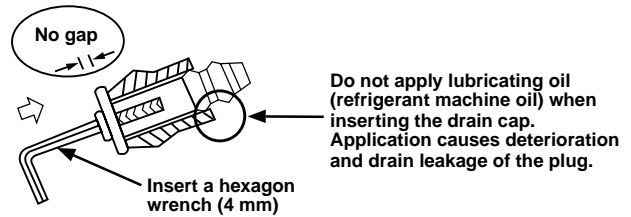


Fig. 8-4-16

CAUTION

Firmly insert the drain hose and drain cap; otherwise, water may leak.

<In case of right or left piping>

- After scribing slits of the front panel with a knife or a making-off pin, cut them with a pair of nippers or an equivalent tool.

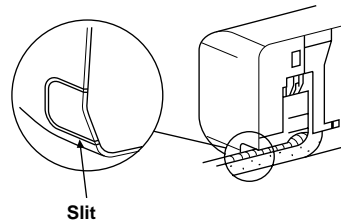


Fig. 8-4-17

<In case of bottom right or bottom left piping>

- After scribing slits of the front panel with a knife or a making-off pin, cut them with a pair of nippers or an equivalent tool.

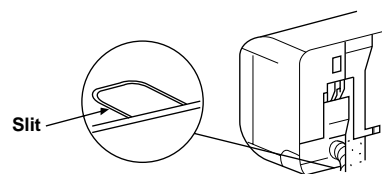


Fig. 8-4-18

<Left-hand connection with piping>

Bend the connecting pipe so that it is laid within 43 mm above the wall surface. If the connecting pipe is laid exceeding 43 mm above the wall surface, the indoor unit may unstably be set on the wall. When bending the connecting pipe, make sure to use a spring bender so as not to crush the pipe.

Bend the connection pipe within a radius of 30 mm.

To connect the pipe after installation of the unit (figure)

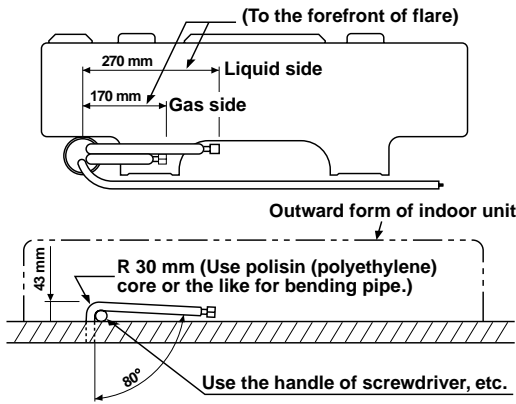


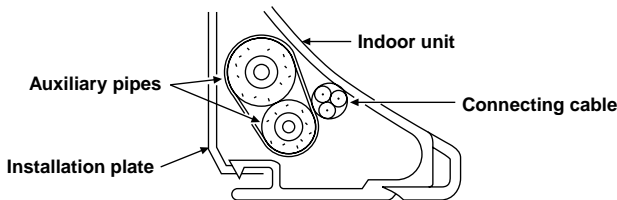
Fig. 8-4-19

NOTE

If the pipe is bent incorrectly, the indoor unit may unstably be set on the wall. After passing the connecting pipe through the pipe hole, connect the connecting pipe to the auxiliary pipes and wrap the facing tape around them.

CAUTION

- Bind the auxiliary pipes (two) and connecting cable with facing tape tightly. In case of leftward piping and rear-leftward piping, bind the auxiliary pipes (two) only with facing tape.



- Carefully arrange pipes so that any pipe does not stick out of the rear plate of the indoor unit.
- Carefully connect the auxiliary pipes and connecting pipes to each other and cut off the insulating tape wound on the connecting pipe to avoid double-taping at the joint, moreover, seal the joint with the vinyl tape, etc.
- Since dewing results in a machine trouble, make sure to insulate both the connecting pipes. (Use polyethylene foam as insulating material.)
- When bending a pipe, carefully do it, not to crush it.

8-4-6. Indoor unit fixing

1. Pass the pipe through the hole in the wall, and hook the indoor unit on the installation plate at the upper hooks.
2. Swing the indoor unit to right and left to confirm that it is firmly hooked up on the installation plate.
3. While pressing the indoor unit onto the wall, hook it at the lower part on the installation plate. Pull the indoor unit toward you to confirm that it is firmly hooked up on the installation plate.

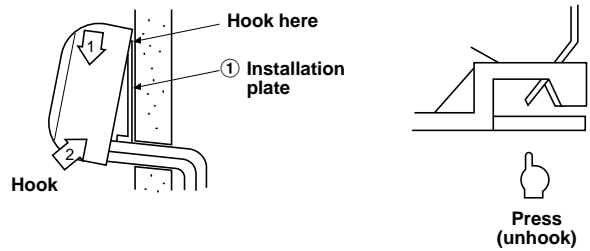


Fig. 8-4-20

- For detaching the indoor unit from the installation plate, pull the indoor unit toward you while pushing its bottom up at the specified parts.

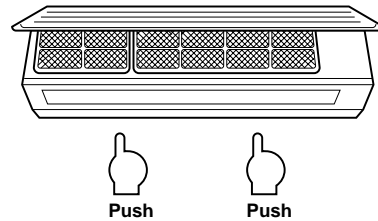


Fig. 8-4-21

8-4-7. Drainage

1. Run the drain hose sloped downwards.

NOTE

- Hole should be made at a slight downward slant on the outdoor side.

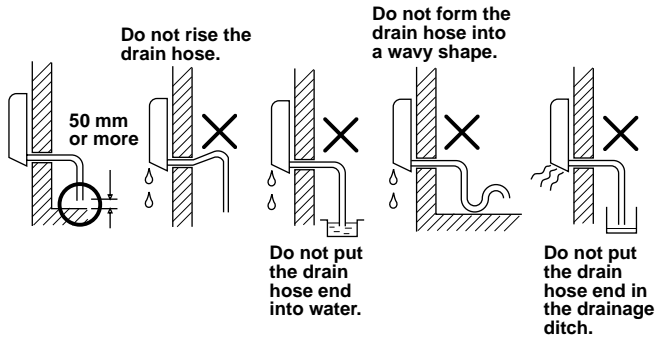


Fig. 8-4-22

2. Put water in the drain pan and make sure that the water is drained out of doors.
3. When connecting extension drain hose, insulate the connecting part of extension drain hose with shield pipe.

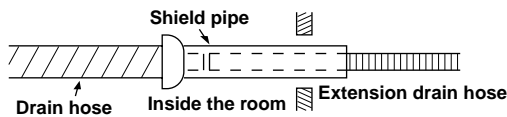


Fig. 8-4-23

CAUTION

Arrange the drain pipe for proper drainage from the unit.
Improper drainage can result in dew-dropping.

This air conditioner has the structure designed to drain water collected from dew, which forms on the back of the indoor unit, to the drain pan. Therefore, do not store the power cord and other parts at a height above the drain guide.

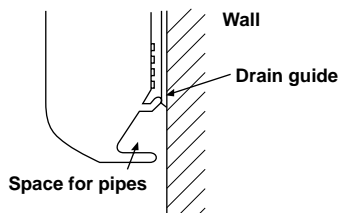


Fig. 8-4-24

8-5. Outdoor Unit

8-5-1. Installation place

- A place which provides the spaces around the outdoor unit as shown in the left diagram.
- A place which can bear the weight of the outdoor unit and does not allow an increase in noise level and vibration.
- A place where the operation noise and discharged air do not disturb your neighbors.
- A place which is not exposed to a strong wind.
- A place free of a leakage of combustible gases.
- A place which does not block a passage.
- When the outdoor unit is to be installed in an elevated position, be sure to secure its feet.
- An allowable length of the connecting pipe is up to 10 m (07, 10 series) or 15 m (13 series).
- An allowable height level is up to 5 m (07, 10 series) or 6 m (13 series).
- A place where the drain water does not raise any problem.

CAUTION

1. Install the outdoor unit without anything blocking the air discharging.
2. When the outdoor unit is installed in a place exposed always exposed to strong wind like a coast or on a high storey of a building, secure the normal fan operation using a duct or a wind shield.
3. In particularly windy areas, install the unit such as to avoid admission of wind.
4. Installation in the following places may result in trouble.

Do not install the unit in such places.

- A place full of machine oil.
- A saline-place such as the coast.
- A place full of sulfide gas.
- A place where high-frequency waves are likely to be generated as from audio equipment, welders, and medical equipment.

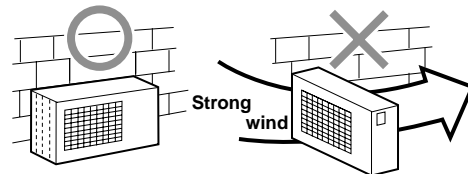


Fig. 8-5-1

8-5-2. Refrigerant piping connection

1. Cut the pipe with a pipe cutter.

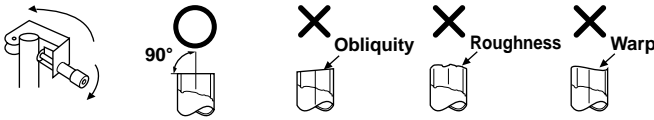


Fig. 8-5-2

2. Insert a flare nut into the pipe, and flare the pipe.

- **Projection margin in flaring : A (Unit : mm)**

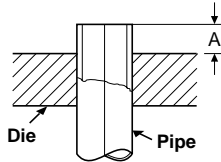


Fig. 8-5-3

Outer dia. of copper pipe	Tightening torque
Ø6.35	16 to 18 (1.6 to 1.8 kgf·m)
Ø9.52	30 to 42 (3.0 to 4.2 kgf·m)
Ø12.70	50 to 62 (5.0 to 6.2 kgf·m)

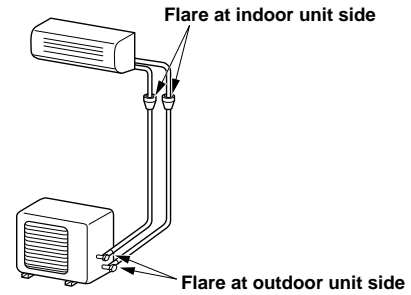


Fig. 8-5-4

Outer dia. of copper pipe	A	
	Rigid	Imperial
6.35	0.5 to 1.0	1.0 to 1.5
9.52	0.5 to 1.0	1.0 to 1.5
12.70	0.5 to 1.0	1.5 to 2.0

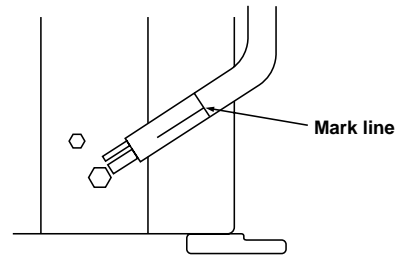
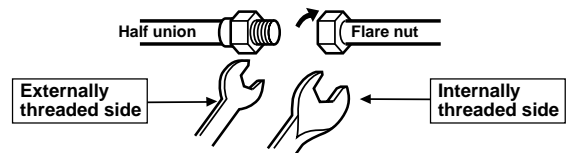


Fig. 8-5-5

<Tightening connection>

Align the centers of the connecting pipes and tighten the flare nut as far as possible with your fingers. Then tighten the nut with a spanner and torque wrench as shown in the figure.



Use a wrench to secure. Use a torque wrench to tighten.

Fig. 8-5-6

CAUTION

- Do not apply excess torque.
- Otherwise, the nut may crack depending on the conditions.

CAUTION

• KEEP IMPORTANT 4 POINTS FOR PIPING WORK

- (1) Take away dust and moisture (Inside of the connecting pipes.)
- (2) Tight connection (between pipes and unit)
- (3) Evacuate the air in the connecting pipes using VACUUM PUMP.
- (4) Check gas leak (connected points)

8-5-3. Evacuating

After the piping has been connected to the indoor unit, you can perform the air purge together at once.

AIR PURGE
 Evacuate the air in the connecting pipes and in the indoor unit using a vacuum pump. Do not use the refrigerant in the outdoor unit.
 For details, see the manual of the vacuum pump.

<Using a vacuum pump>

Be sure to use a vacuum pump with counter-flow prevention function so that inside oil of the pump does not flow backward into pipes of the air conditioner when the pump stops.

1. Connect the charge hose from the manifold valve to the service port of the gas side packed valve.
2. Connect the charge hose to the port of the vacuum pump.
3. Open fully the low pressure side handle of the gauge manifold valve.
4. Operate the vacuum pump to start evacuating. Perform evacuating for about 15 minutes if the piping length is 20 meters. (15 minutes for 20 meters) (assuming a pump capacity of 27 liters per minute.) Then confirm that the compound pressure gauge reading is -101 kPa (-76 cmHg).
5. Close the low pressure side valve handle of gauge manifold.
6. Open fully the valve stem of the packed valves (both sides of Gas and Liquid).
7. Remove the charging hose from the service port.
8. Securely tighten the caps on the packed valves.

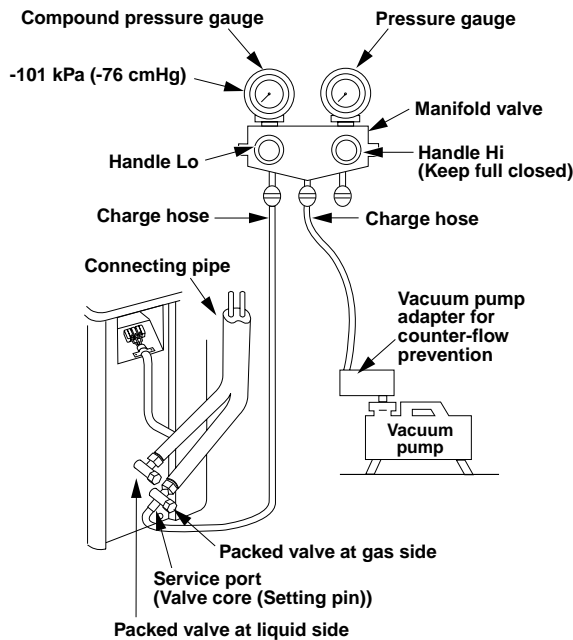


Fig. 8-5-7

<Packed valve handling precautions>

- Open the valve stem all the way out; but do not try to open it beyond the stopper.
- Securely tighten the valve stem cap with torque in the following table:

Gas side ($\text{Ø}12.70 \text{ mm}$)	50 to 62 N·m (5.0 to 6.2 kgf·m)
Gas side ($\text{Ø}9.52 \text{ mm}$)	30 to 42 N·m (3.0 to 4.2 kgf·m)
Liquid side ($\text{Ø}6.35 \text{ mm}$)	16 to 18 N·m (1.6 to 1.8 kgf·m)
Service port	9 to 10 N·m (0.9 to 1.0 kgf·m)

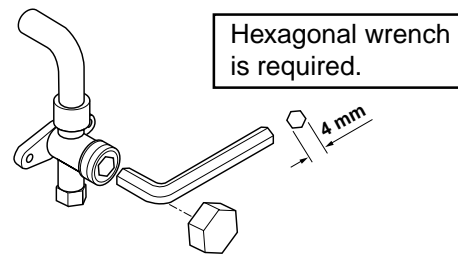


Fig. 8-5-8

8-5-4. Wiring connection

1. Remove the valve cover from the outdoor unit.
2. Connect the connecting cable to the terminal as identified with their respective matched numbers on the terminal block of indoor and outdoor unit.
3. When connecting the connecting cable to the outdoor unit terminal, make a loop as shown in the installation diagram of indoor and outdoor unit, to prevent water coming in the outdoor unit.
4. Insulate the unused cords (conductors) from any water coming in the outdoor unit. Proceed them so that they do not touch any electrical or metal parts.

<Stripping length of connecting cable>

For RAS-13/10/07UAH-E3

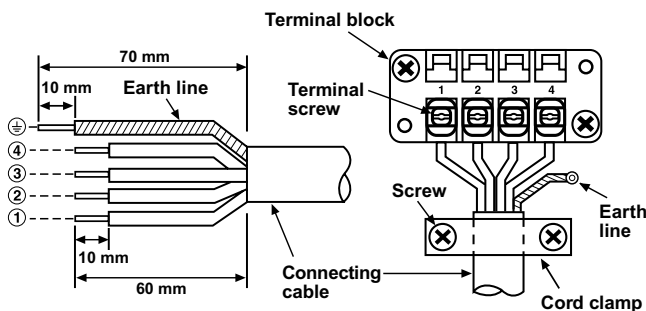


Fig. 8-5-9

For RAS-13/10/07UA-E3

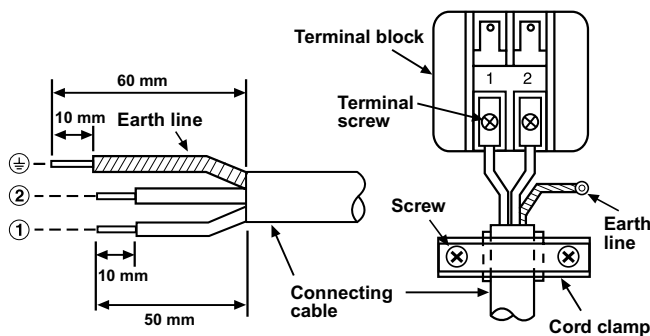


Fig. 8-5-10

CAUTION

- Wrong wiring connection may cause some electrical parts burn out.
- Be sure to comply with local codes on running the wire from indoor unit to outdoor unit (size of wire and wiring method etc.)
- Every wire must be connected firmly.

NOTE

- Wire type: H07 RN-F or 245 IEC66 (2.0 mm² or more)

8-6. How to Set Remote Control Selector Switch

When two indoor units are installed in separated rooms, there is no need to change the selector switch.

<Remote control selector switch>

- When two indoor units are installed in the same room or the adjacent two rooms, they may be controlled simultaneously with a single remote control. To prevent this, set either unit and its remote control to B setting. (Both units are set to A setting before shipment.)
- The remote control signal is not received when the indoor unit setting is different from the remote control one.

1. Set the remote control selector switch with the indoor unit.

- 1) Turn the circuit breaker of the main power switch off before setting the selector switch.
- 2) Remove the Air inlet grille and Front panel.
- 3) Select the terminal of selector switch from [A position] to [B position].

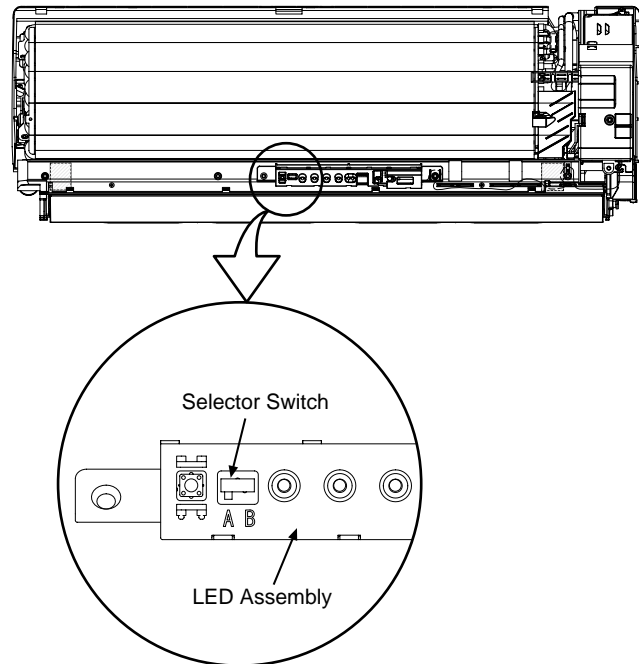


Fig. 8-6-1

2. Set the remote control selector switch with the remote control

[B] is indicated on the liquid crystal display when setting remote control selector switch to B. [A] is not indicated on the display even if the selector switch is set to A.

- 1) Load the remote control with the batteries.
 - 2) Press the [CHECK] button using something with sharp point. (The preset temperature on the remote control changes to [00].)
 - 3) Press the [MODE] button while pressing the [CHECK] button, [B] is indicated at the right of the present temperature display.
- To reset the switch to the [A] setting, press the [MODE] button again while pressing the [CHECK] button.

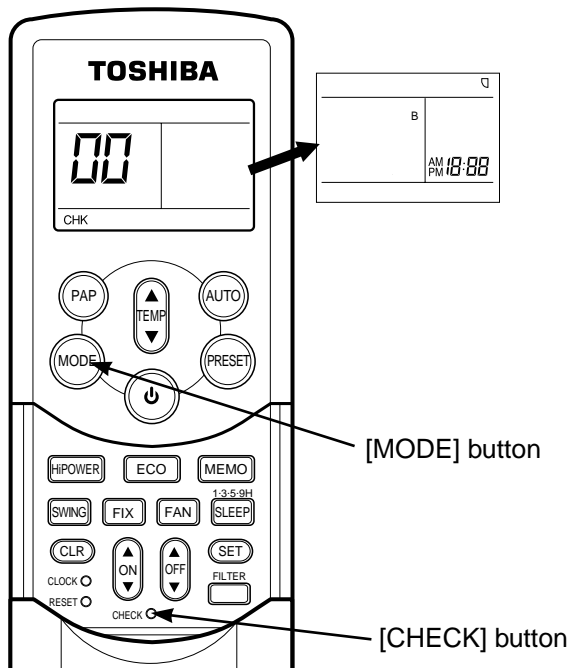


Fig. 8-6-2

3. Confirm that the indoor unit can operate with the new setting.

8-7. Others

8-7-1. Gas leak test

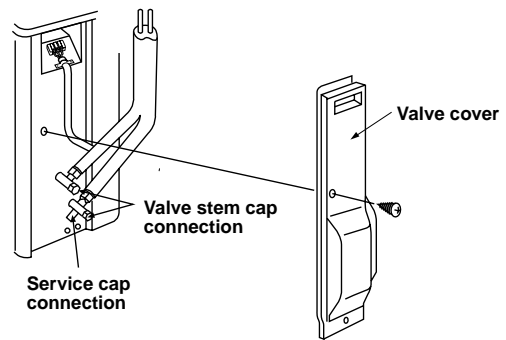


Fig. 8-7-1

- Check the flare nut connections, valve stem cap connections and service port cap connections for gas leak with a leak detector or soap water.

8-7-2. Test operation

To switch the TEST RUN (COOL) mode, press RESET button for 10 sec.
(The beeper will make a short beep.)

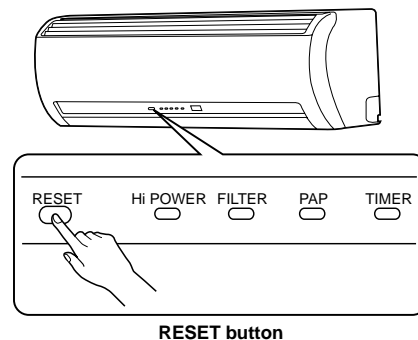


Fig. 8-7-2

8-7-3. Auto restart setting

This product is designed so that, after a power failure, it can restart automatically in the same operating mode as before the power failure.

Information

The product was shipped with Auto Restart function in the off position. Turn it on as required.

<How to set the auto restart>

- Press and hold the RESET button for about 3 seconds. After 3 seconds, the electronic beeper makes three short beeps to tell you the Auto Restart has been selected.
- To cancel the Auto Restart, follow the steps described in the section Auto Restart Function of the Owner's Manual.

9. TROUBLESHOOTING CHART

9-1. Troubleshooting Procedure

Follow the details of 9-2. Basic Check Items .
If there is no trouble corresponding to 9-2, check whether or not there are faulty parts following 9-4. Self-Diagnosis by Remote Control.

9-2. Basic Check Items

9-2-1. Power supply voltage

The line voltage must be AC 220 – 240 V. If it is not within this range, the air conditioner may not operate normally.

9-2-2. Incorrect cable connection between Indoor and outdoor units

The indoor unit is connected to the outdoor unit with 3 cables (Cooling Only model) or 5 cables (Heat Pump model). Check that the indoor and outdoor units have been properly connected with terminals assigned the same numbers. If the connectors are not properly connected, the outdoor unit will not operate normally, or OPERATION lamp and TIMER lamp will blink (5Hz).

9-2-3. Program control

The microcontroller operates as shown in Table 9-2-1 to control the air conditioner. If there are any operational problems, check whether or not the problems correspond to Table 9-2-1. If they correspond to the Table, they are not problems with the air conditioner, but they are indispensable operations to control and maintain the air conditioner properly.

Table 9-2-1

No.	Operation of air conditioner	Descriptions
1	When the main power supply is turned on, the OPERATION lamp on the indoor unit blinks.	The OPERATION lamp blinks to indicate that power is turned on. If the [⏻] button is pressed, the lamp stops blinking.
2	The indoor fan motor speed does not change in the Dry operation.	The indoor fan motor speed is automatically controlled in the Dry operation.
3	The compressor is not turned off even though the room temperature is in the range that the compressor is turned off.	The compressor has a function that it is not turned off for 3 minutes after it is turned on even though the room temperature is in the range that the compressor is turned off.
4	The compressor is not turned on and off even though the thermo control is operated in the Dry operation.	In the Dry operation, the compressor is turned on and off automatically at the regular intervals, independent of the thermo control.
5	The compressor is not turned on even though the room temperature is in the range that the compressor is turned on.	The compressor is not turned on in the restart delay timer (3-minutes timer) operation. It is also not turned on after the power supply is turned on because of this timer operation.
6	The operation mode changes in the Automatic operation.	In Automatic operation, the room temperature is detected all time for control fan speed and the operation mode is changed every 15 minutes according to difference between the room temperature and the preset temperature.
7	The Fan only operation continues in the Automatic operation.	When the room temperature is in the range (Preset temperature $\pm 1^{\circ}\text{C}$), the Fan only operation is selected.
8	The Hi-POWER operation does not work.	This operation does not work when the unit is in the Dry operation or Fan only operation.

9-3. Primary Judgement

9-3-1. Role of indoor unit controller

The indoor unit controller receives the operation commands from the remote control and executes them.

- Temperature measurement at the air outlet of the indoor heat exchanger by the indoor temperature sensor
- Temperature setting of the indoor heat exchanger by the heat exchanger sensor
- Louver motor control
- Indoor fan motor operation control
- LED display control
- Transferring of operation commands to the outdoor unit

9-3-2. Failure diagnosis

The indoor unit diagnoses the operation condition and indicates the information of the self-diagnosis with the lamps on the display panel of the indoor unit.

Table 9-3-1

	Lamps	Self-diagnosis
A	OPERATION lamp is blinking. (1Hz)	Power failure (when the power supply is turning on)
B	OPERATION lamp is blinking. (5Hz)	Thermo sensor (TA) short or break
C	OPERATION lamp is blinking. (5Hz)	Heat exchanger sensor (TC) short or break
D	OPERATION lamp is blinking. (5Hz)	Indoor fan motor lock or failure
E	OPERATION lamp is blinking. (5Hz)	Indoor P.C. board failure
F	OPERATION and TIMER lamps are blinking. (5Hz)	Wrong wiring of connecting cable
G	OPERATION, TIMER and PAP lamps are blinking.	Cycle failure <ul style="list-style-type: none"> • Gas shortage or other refrigerant cycle trouble • Heat exchanger sensor open, break or short • Overload relay or thermostat trouble of compressor

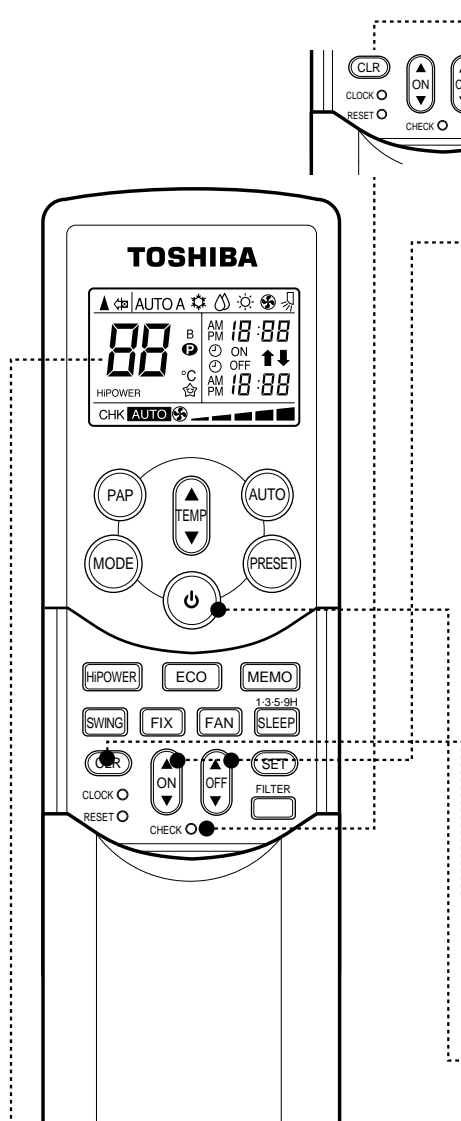
Table 9-3-2 Diagnosis by detective operation

Symptom	Check	Primary judgement	
The remote control does not work.	Turn off the power supply once, then turn it on. Try to operate the remote control.	The remote control still does not work.	The indoor unit (and/or remote control) is/are defective.
		The remote control works.	OK.
The outdoor fan does not rotate.	The compressor operates.	The outdoor unit (Outdoor fan motor) is defective.	
	The compressor does not operate.	An internal part of the compressor or P.C. board is defective.	

9-4. Self-Diagnosis by Remote Control (Check Code)

- (1) If the lamps are indicated as shown B to G in Table 9-3-1, exchanger the self-diagnosis by the remote control.
- (2) When the remote control is set to the service mode, the indoor controller diagnoses the operation condition and indicate the information of the self-diagnosis on the display of the remote control with the check codes. If a fault is detected, all lamps on the indoor unit will blink at 5Hz and it will beep for 10 seconds (Pi, Pi, Pi...). The timer lamp usually blinks (5Hz) during the self-diagnosis.

9-4-1. How to use remote control in service mode



- (1) Press [CHECK] button with a tip of pencil to set the remote control to the service mode.
 - “00” is indicated on the display of the remote control.
 - The timer lamp on the indoor unit blinks continuously. (5 times per 1 sec.)

- (2) Press [ON ▲] or [OFF ▼] button. If there is no fault with a code, the indoor unit will beep once (Pi) and the display of the remote control will change as follows:

→ 00 → 01 → 02 ... 1d → 1E → 33

- Check the unit with all 52 check codes (00 to 33), as shown in Table 9-4-1.
- Press [ON ▲] or [OFF ▼] button to change the check code backwards.

If there is a fault, the indoor unit will beep for 10 seconds (Pi, Pi, Pi...). Note the check code on the display of the remote control.

- 2-digits alphanumeric will be indicated on the display.
- All lamps on the indoor unit will blink. (5 times per 1 sec.)

- (3) Press [CLR] button. After service finish for clear service code in memory.
 - “7F” is indicated on the display of the remote control.

- (4) Press [⏻] button to release the service mode.
 - The display of the remote control returns to as it was before service mode was engaged.

- Alphanumeric characters are used for the check code.

S is 5. *B* is 6.
A is A. *b* is B.
L is C. *d* is D.

- (5) Time shortening method.
 1. Press [SET] button while pressing [CHECK] button.
 2. Press [⏻] button.

Table 9-4-1

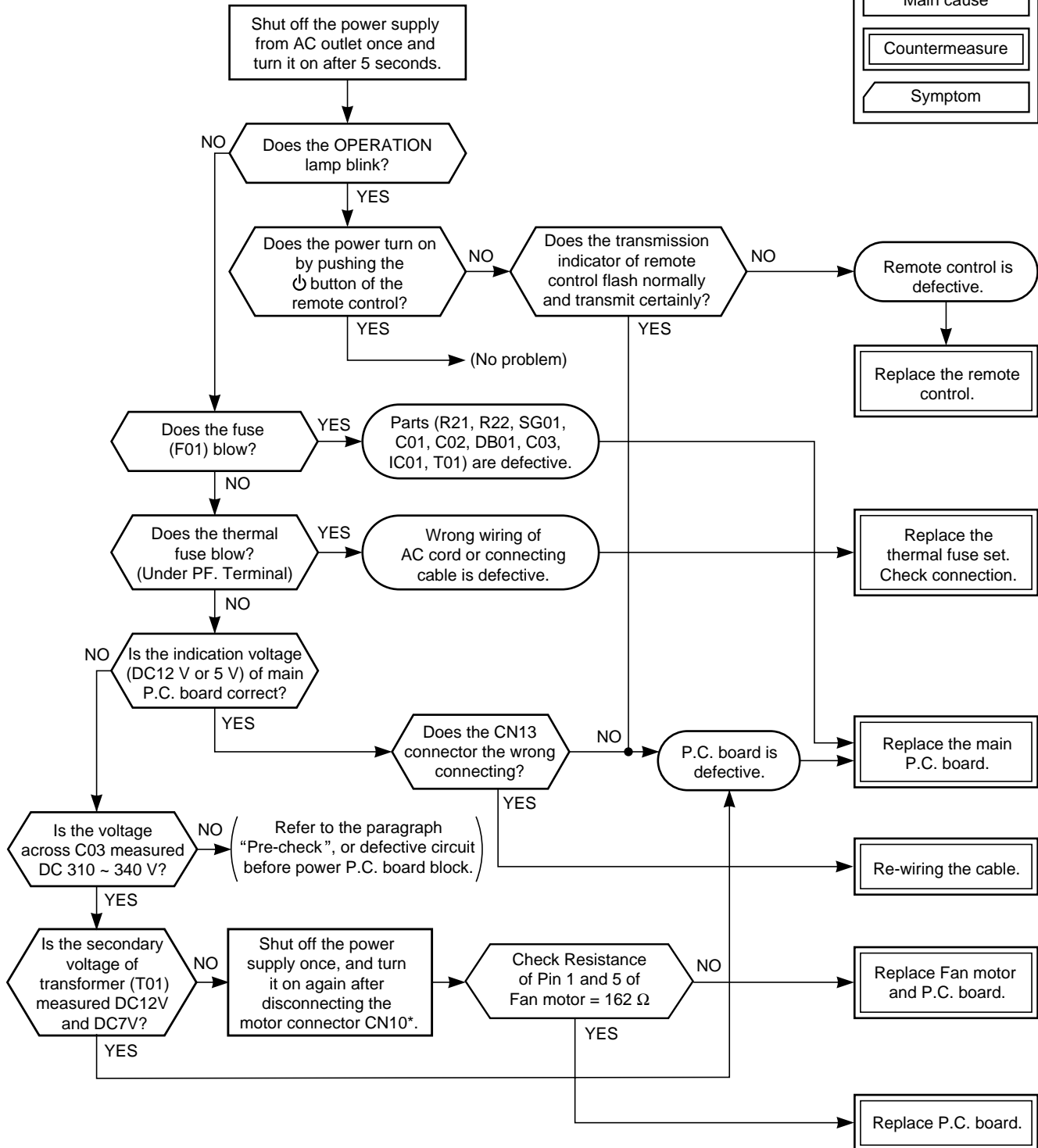
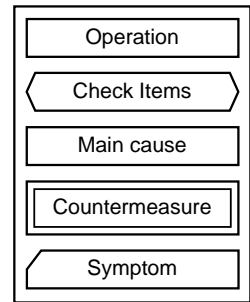
Block level		Diagnosis function				Judgement and action
Check code	Block	Check code	Symptom	Air Conditioner status	Condition	
00	Indoor P.C. board	01	Thermo. sensor short/break.	Continued operation.	Indicated when detected abnormal	1. Check thermo sensor. 2. If it is OK, check P.C. board.
		02	Heat exchanger sensor short/break.	Continued operation.	Indicated when detected abnormal	1. Check heat exchanger sensor. 2. If it is OK, check P.C. board.
		11	Indoor fan lock, abnormality of indoor fan or thermal fuse break.	All off	Indicated when detected abnormal	1. Check heat thermal fuse is blow or not? (Terminal block part.) 2. If the thermal fuse is not blow, check indoor fan motor. (Refer to trouble shooting flow charts.)
		12	Abnormality of other indoor unit P.C. board.	All off	Indicated when detected abnormal	Replace P.C. board.
01	Cable connection/ Thermal fuse Refrigerant system	04	1) Wrong wiring or disconnection of connective cable. 2) Terminal fuse cut off.	All off	Indicated when detected abnormal	1. Check connective cable correct if wiring is wrong. 2. Check thermal fuse and Terminal blocks. 3. If it is OK, check P.C. board.
03	Other parts (including compressor)	09	1) Overload relay or thermostat for compressor break.	All off	Indicated when detected abnormal	1. If overload relay and thermostat for compressor are OK, check refrigerant cycle. 2. If refrigerant cycle is OK, check P.C. board. 3. If heat exchanger sensor is OK, check overload relay and thermostat for compressor.
Content detected by the check codes "04" to "12" are stored in memory of the microcomputer even if the power supply is turned off. Therefore, contents of operations in the past are all displayed.						

9-5. Troubleshooting Flowcharts

9-5-1. Power can not be turned on (No operation at all)

<Preliminary checks>

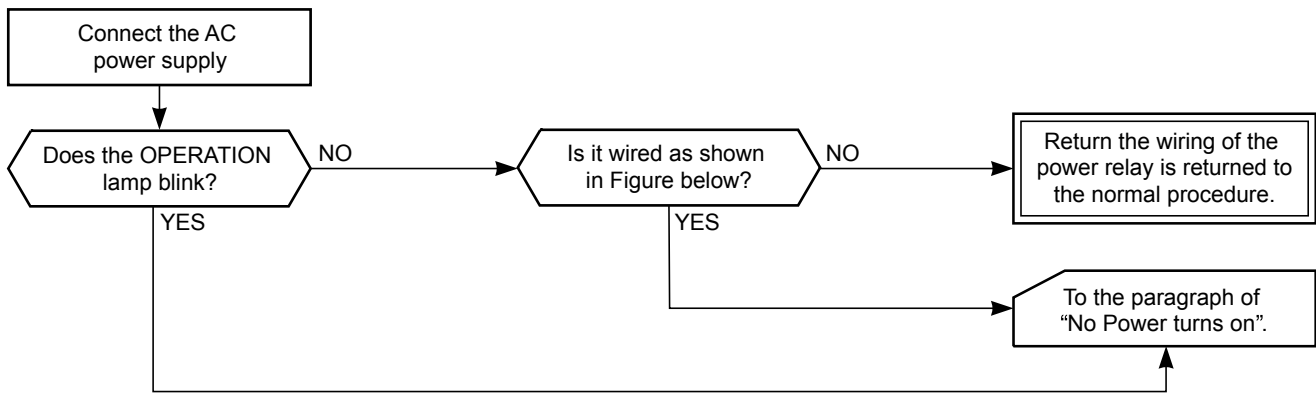
- (1) Is the supply voltage normal?
- (2) Is the connection to the AC output OK.?



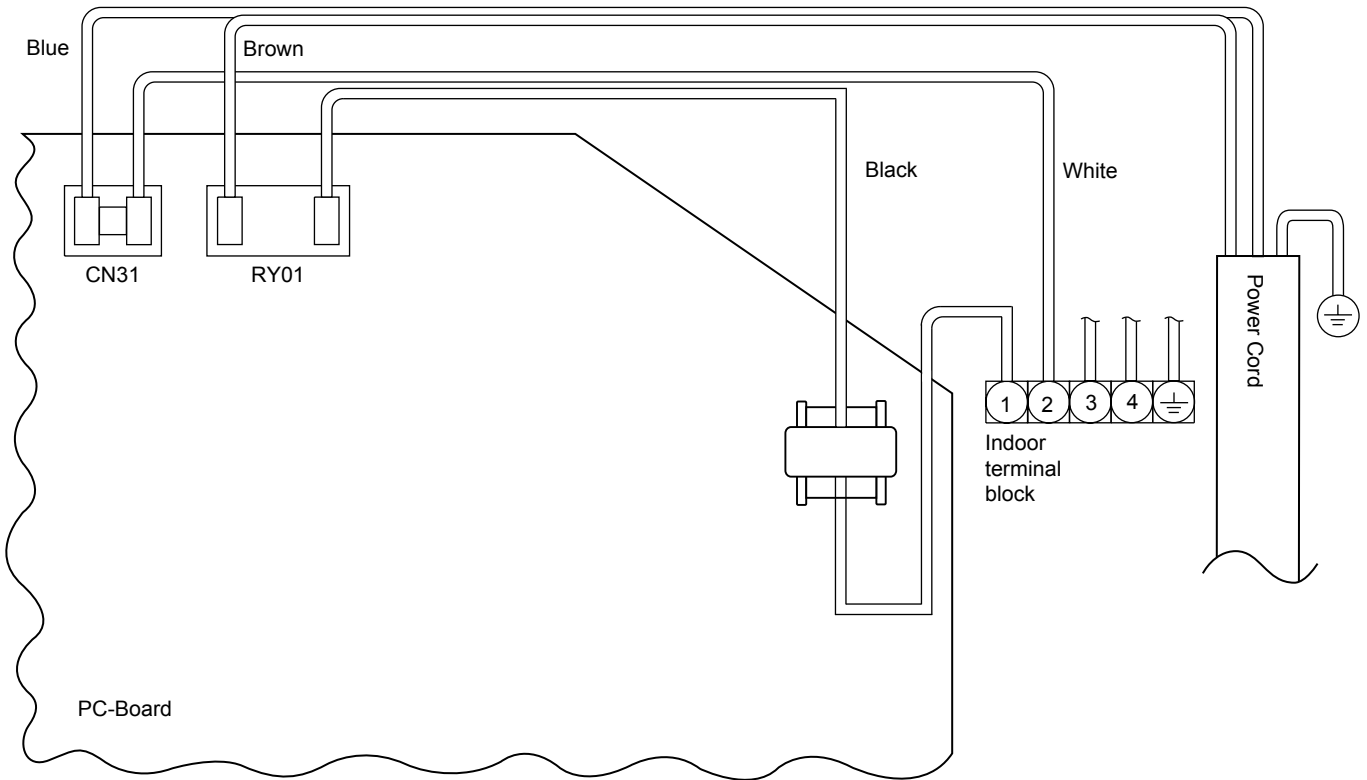
* Be sure to disconnect the motor connector CN10 after shut off the power supply, or it will be a cause of damage of the motor.

9-5-2. Power cannot be turned on after replacing indoor P.C. board

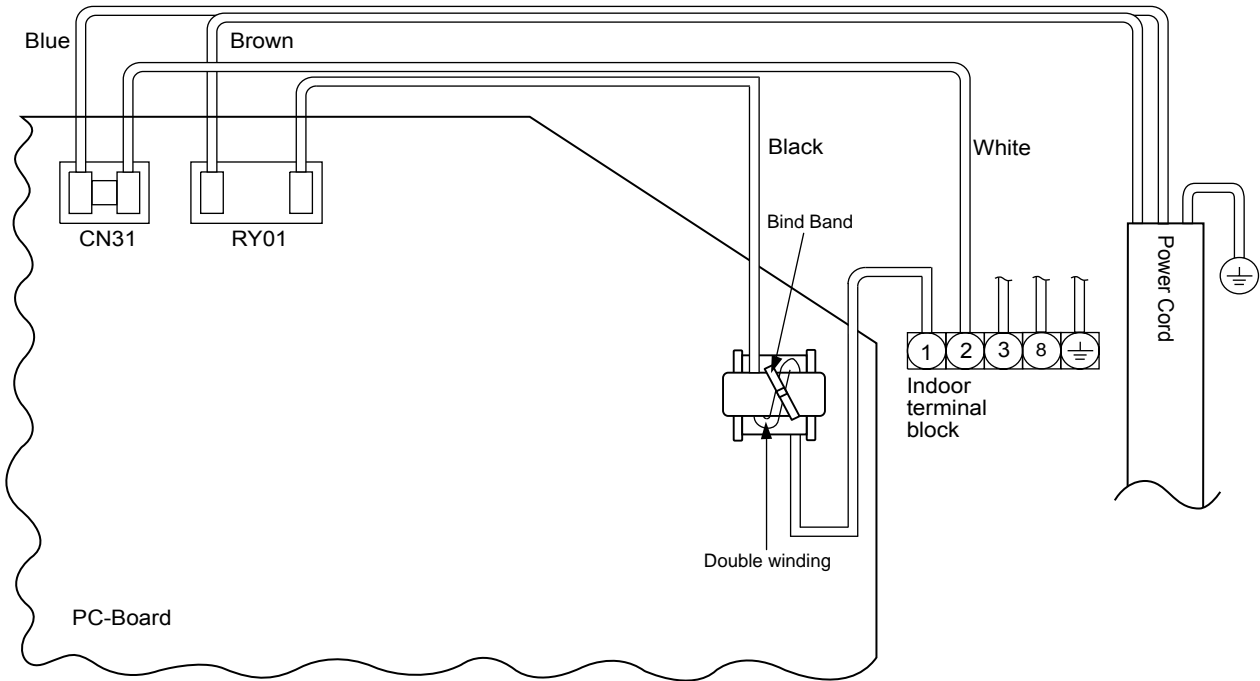
<Checking Procedure>



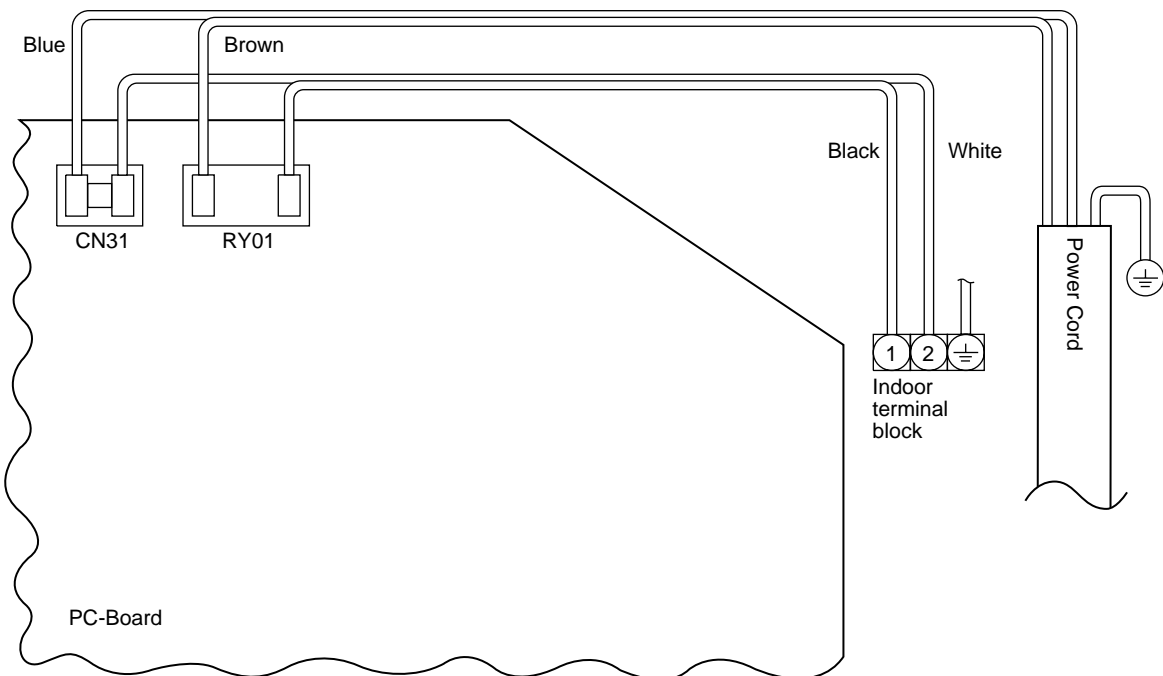
RAS-13NKHD-E



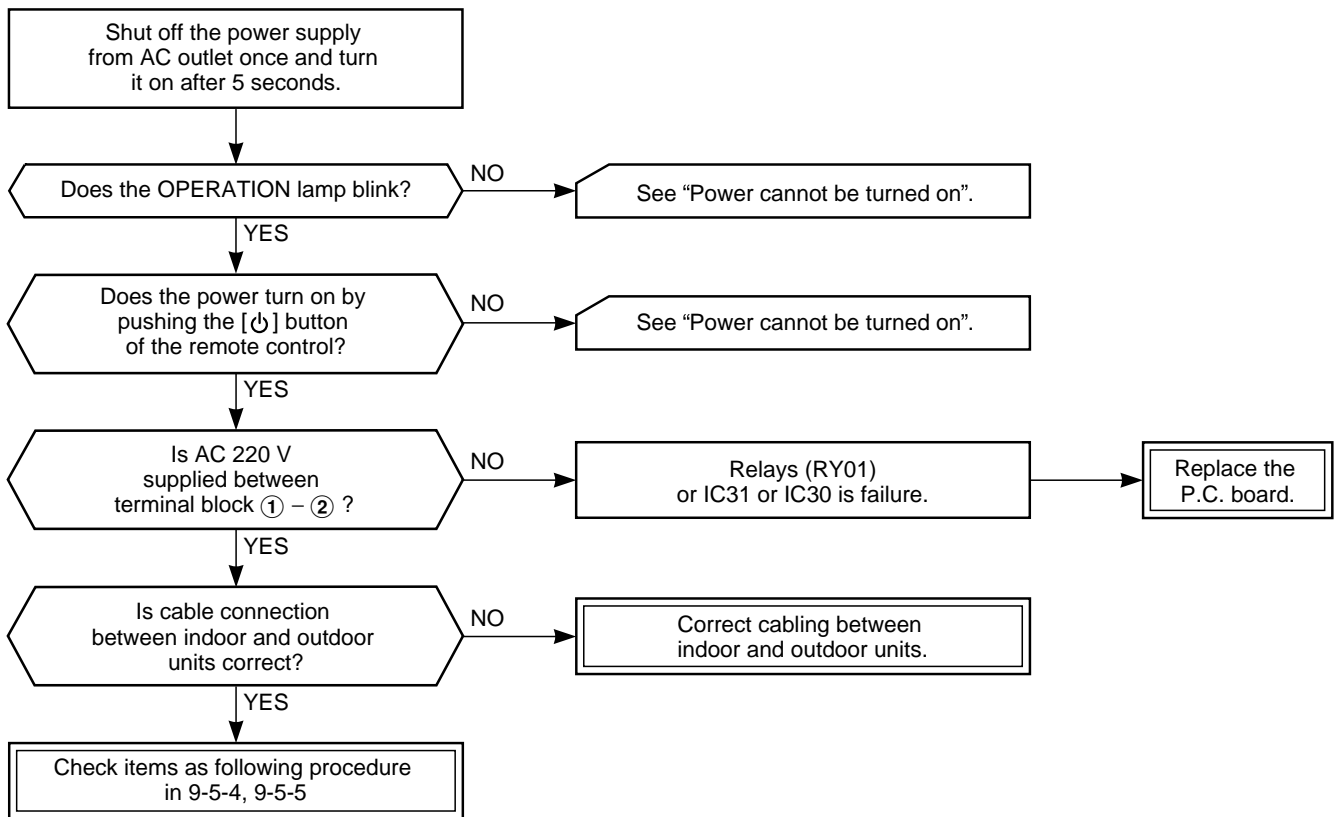
RAS-07NKHD-E, RAS-10NKHD-E



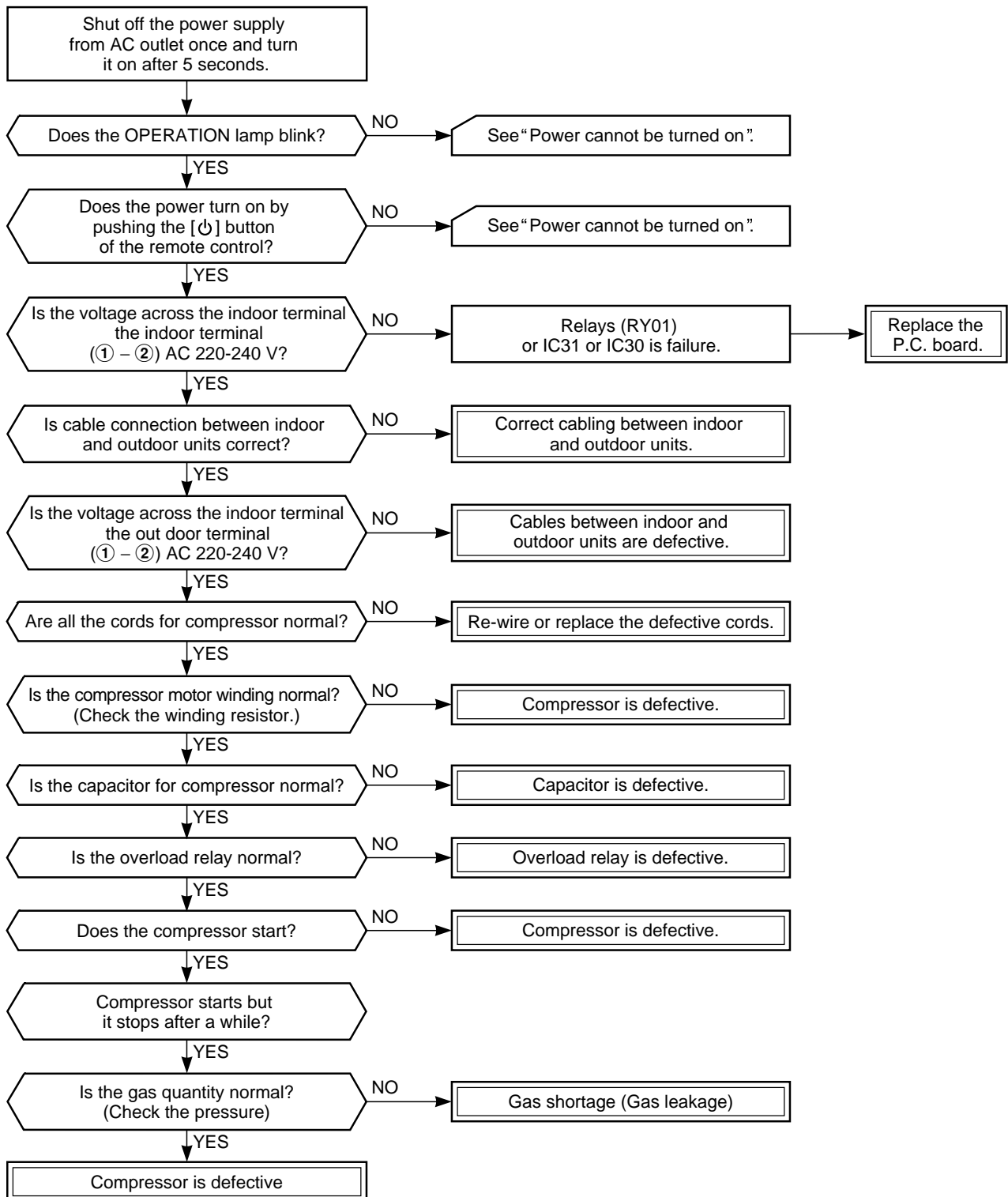
RAS-07NKD-E, RAS-10NKD-E, RAS-13NKD-E



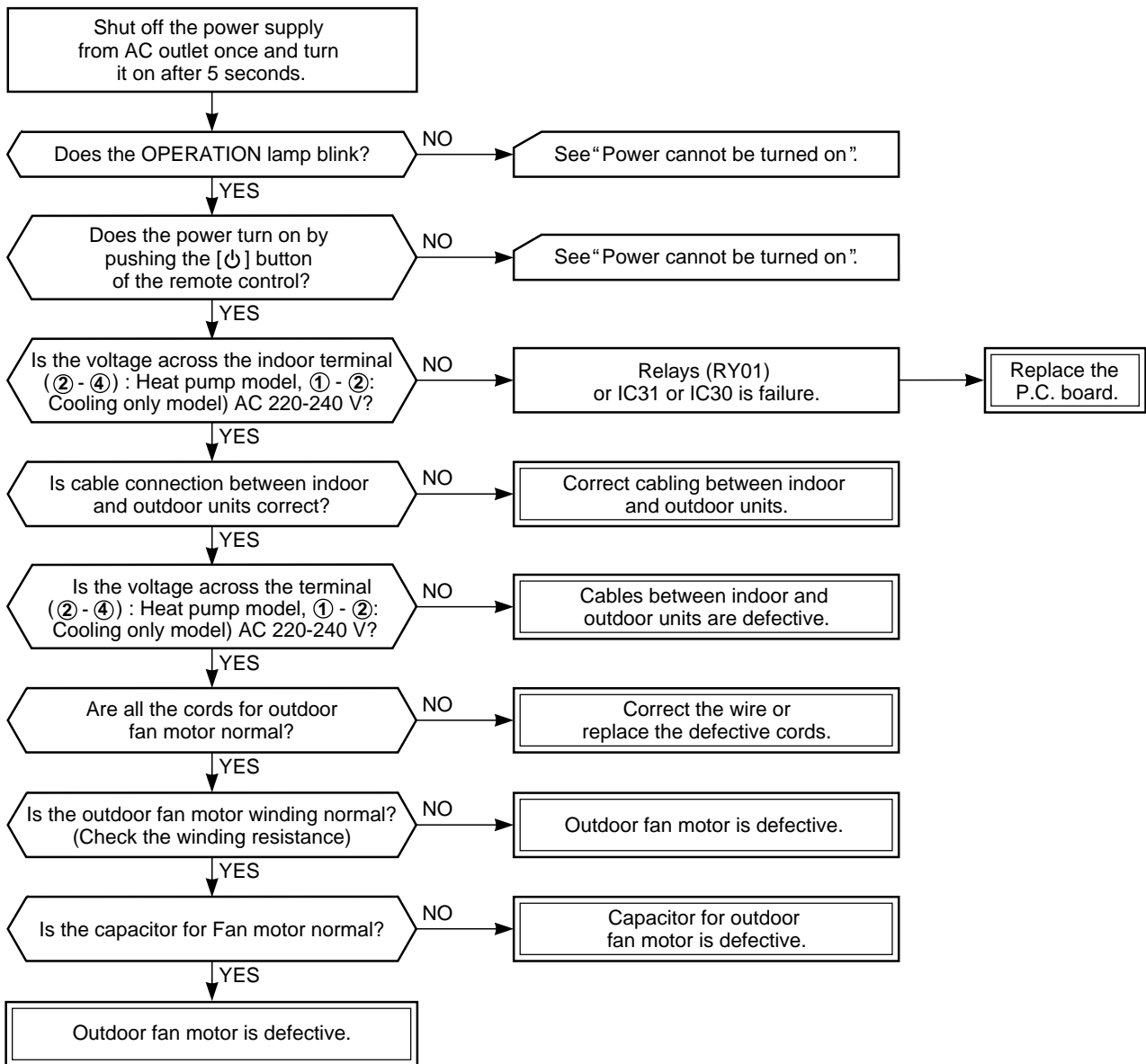
9-5-3. Outdoor unit does not operate



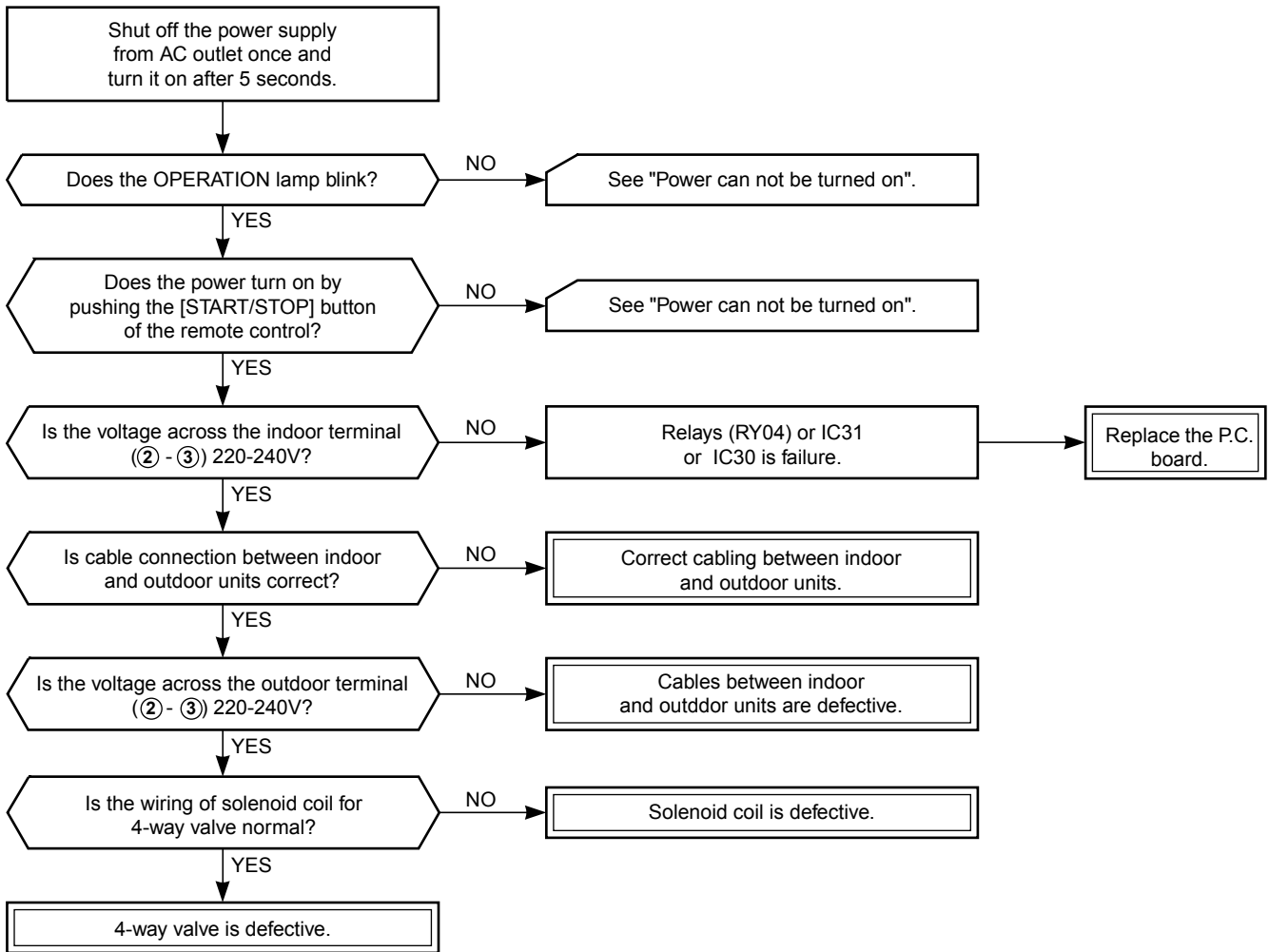
9-5-4. Only compressor does not operate



9-5-5. Only outdoor fan does not operate

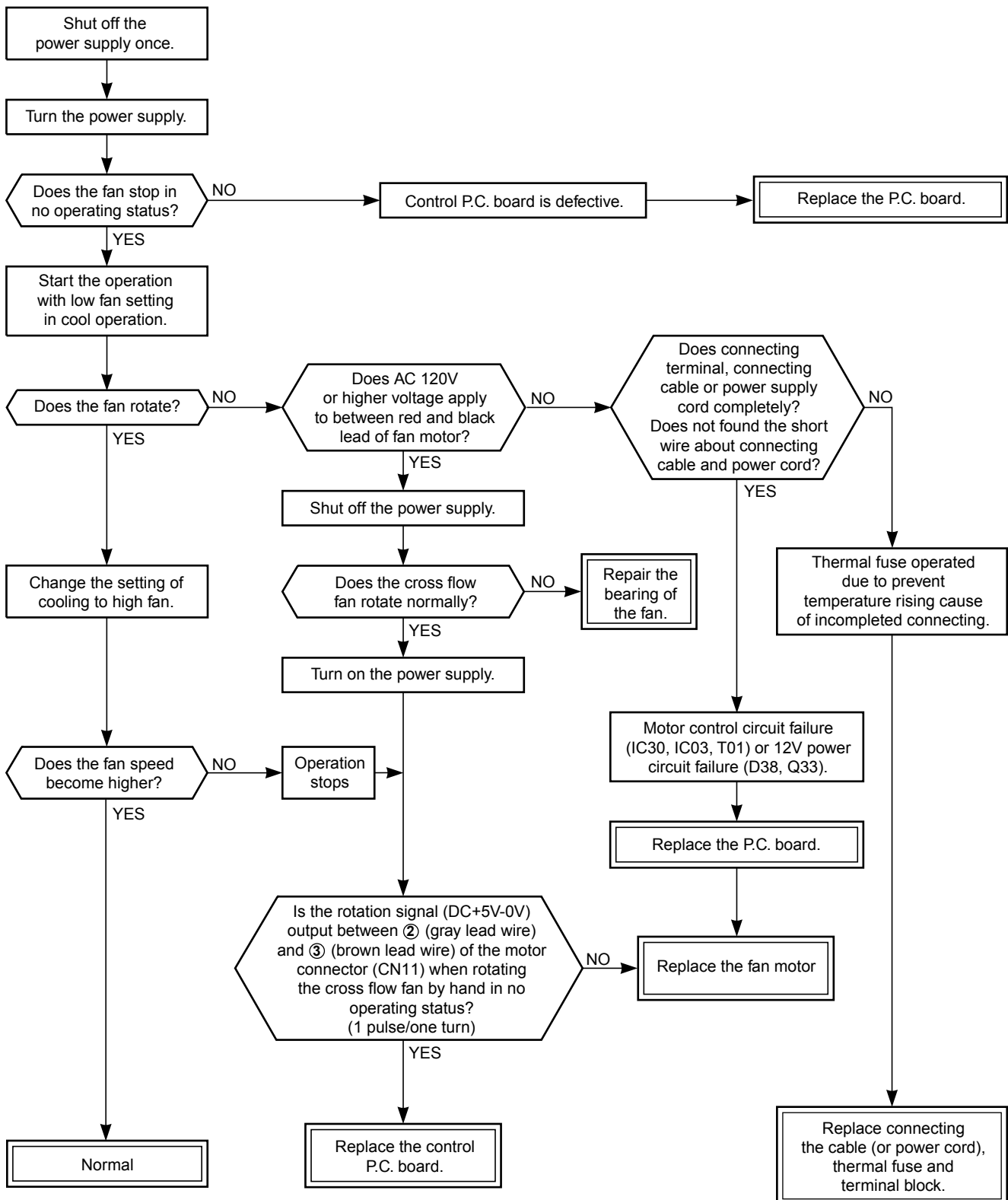


**9-5-6. Only 4-Way valve does not operate (During heating operation)
Heat Pump Model**

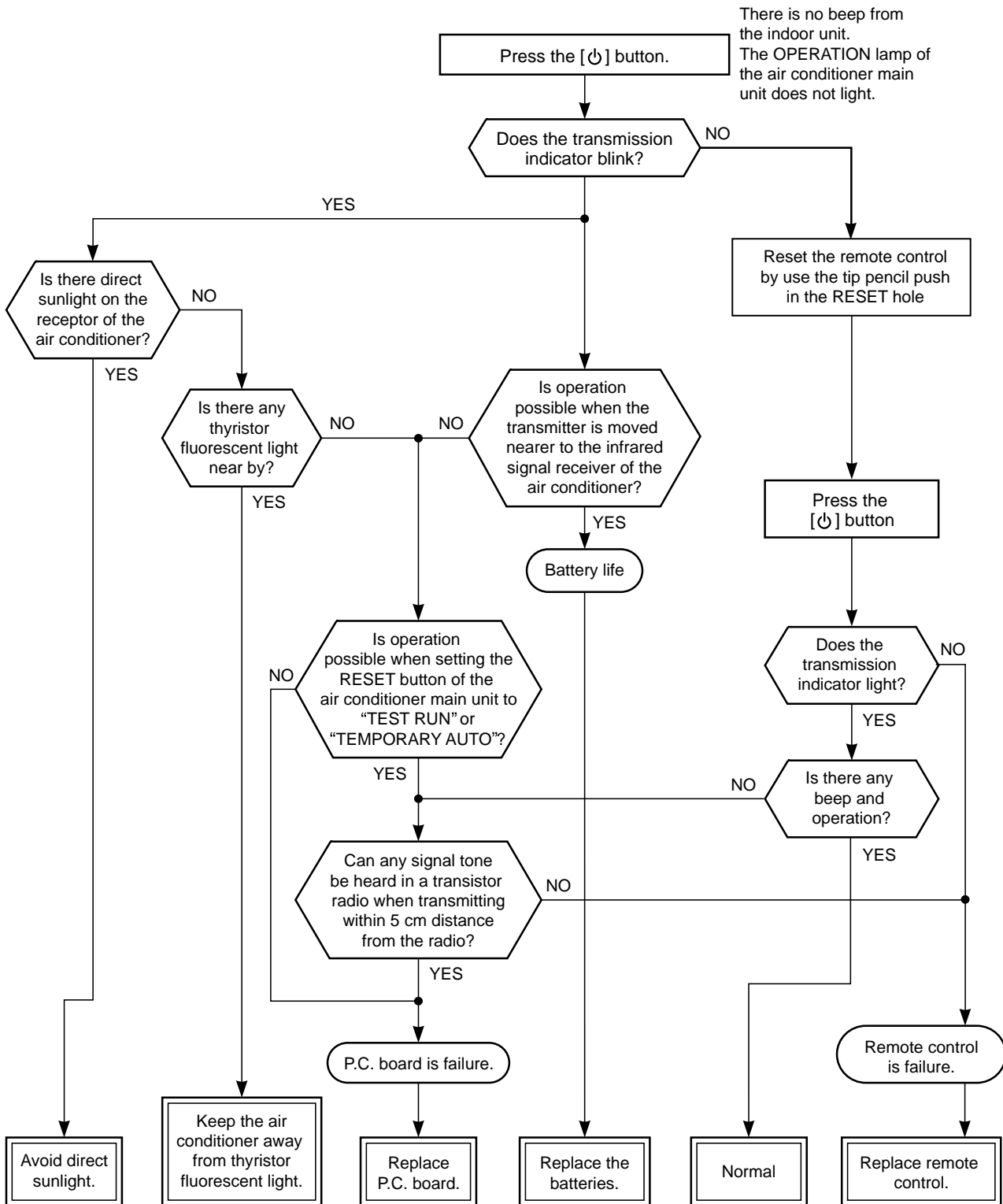


9-5-7. Only the indoor fan does not operate

<Check procedure>



9-6. Troubleshooting for Remote Control (Including the Indoor P.C. Board)



Note : After battery replacement, short circuit the metal terminal at the side of the battery compartment (all-clear terminal) with a pencil.

9-6-1. How to check the P.C. board

(1) Operating precautions

- 1) When removing the front panel or the P.C. board, be sure to shut off the power supply.
- 2) When removing the P.C. board, hold the edge of the P.C. board and do not apply force to the parts.
- 3) When connecting or disconnecting the connectors on the P.C. board, hold the Whole housing.
Do not pull at the lead wire.

(2) Inspection procedures

- 1) When a P.C. board is judged to be defective, check for disconnection, burning, or discoloration of the copper foil pattern or this P.C. board.
- 2) The P.C. board consists of the following 2 parts
 - a. Main P.C. board part:**
Power relay, indoor fan motor drive circuit and control circuit, C.P.U. and peripheral circuits, buzzer drive circuit and buzzer.
 - b. Infrared rays receive and indication parts:**
Infrared rays receiver unit and LED.

(3) Checking procedure

Table 9-6-1

No.	Procedure	Check Point (Symptom)	Causes
1	Shut off the power supply and remove the P.C. board assembly from the electronic parts base. Remove the connecting cable from the terminal block.	1. Is the fuse blown?	1. Application of shock voltage. Overload by short-circuit of the parts.
2	Remove the connector for the motor, and turn the power on. If the OPERATION lamp blinks (0.5 sec. : ON, 0.5 sec. : OFF) when the power turning on, the checking points described as 1-4 of right column are not necessary to perform.	Voltage check 1. Between ③ of RY01 and CN31 (AC 220 ~ 240 V) 2. Between + and - of C03 (DC 310 ~ 340 V) 3. Between 5V and GND 4. Between 12V and GND	1. AC power cord is defective. Poor contact of the terminal plate. Miss wiring of the power relay. 2. Capacitor (C01, C02) is defective. Line filter (L01) is defective. Resistor (R01) is defective. Diode (DB01) is defective. 3. IC01, T01, F03 are defective. 4. IC01, T01 are defective.
3	Make the operation status by pressing once the [⏻] button, except the status of [FAN ONLY], [ON TIMER].	Voltage check 1. Voltage of relay coil. (DC 12 V) Between pin 10 of IC31 and GND Between pin 11 of IC31 and GND	1. Breaking wire of the relay coil, defective relay driver. (IC31)
4	Start the operation with the system which the time of the restart delay timer is shortened.	1. All indicators light for 3 sec.. 2. Indicators do not indicate normally after approximate 3 sec..	} Defective indicator, or poor housing assembly. (CN13)
5	Make the operation status by pressing once the [⏻] button. 1. The time of the restart delay timer is shortened. 2. Cool operation 3. Air volume [AUTO] 4. Make the setting temperature lower enough than room temperature. 5. Continuous operation.	1. Compressor does not operate. 2. OPERATION lamp blinks.	1. The temperature of the indoor heat exchanger is abnormally lower. 2. Poor contact of the heat exchanger sensor. (The connector is disconnected.) (CN01) 3. Heat exchanger sensor, main P.C. board are defective. (Refer to Table 9-6-2 for the judgment of defective resistance values.) 4. Main P.C. board is defective.
6	The status of No. 5 is continued, and make the following condition. 1. Heat operation 2. Make the setting temperature higher enough than room temperature.	1. Compressor does not operate. 2. OPERATION lamp blinks.	1. The temperature of the heat exchanger is abnormally high. 2. The heat exchanger sensor connector has short-circuit. (CN01) 3. The heat exchanger sensor is defective. (Refer to Table 9-6-2 for the judgment of defective resistance values.) 4. P.C. board is defective.
7	Turn the power on after connecting the motor connector. Start the operation with the following condition. 1. Operation [Cooling] 2. Airflow [High fan] 3. Continuous operation	1. Motor does not rotate. (The key operation is accepted.) 2. The Motor rotates, but it vibrates too much.	1. Poor contact of the motor connector. 2. P.C. board is defective.

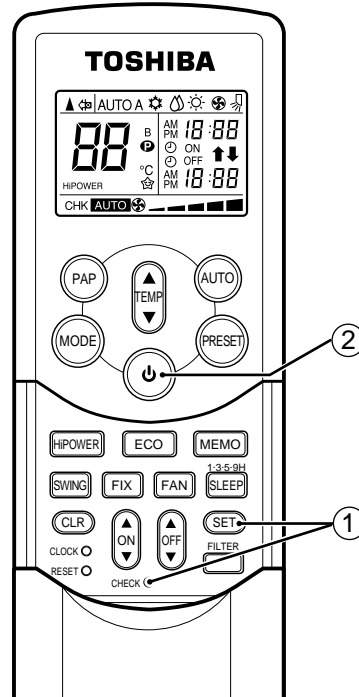
Table 9-6-2. Approximate resistance value of thermo sensor

Temperature	0°C	10°C	20°C	25°C	30°C
Resistance value	33.8	20.35	12.59	10.00	7.99

(kΩ)

9-6-2. How to shorten time of restart delay timer

- ① Press [SET] button while pressing [CHECK] button with a tip of a pencil.
- ② Then press [⏻] button to transmit the signal to the indoor unit.

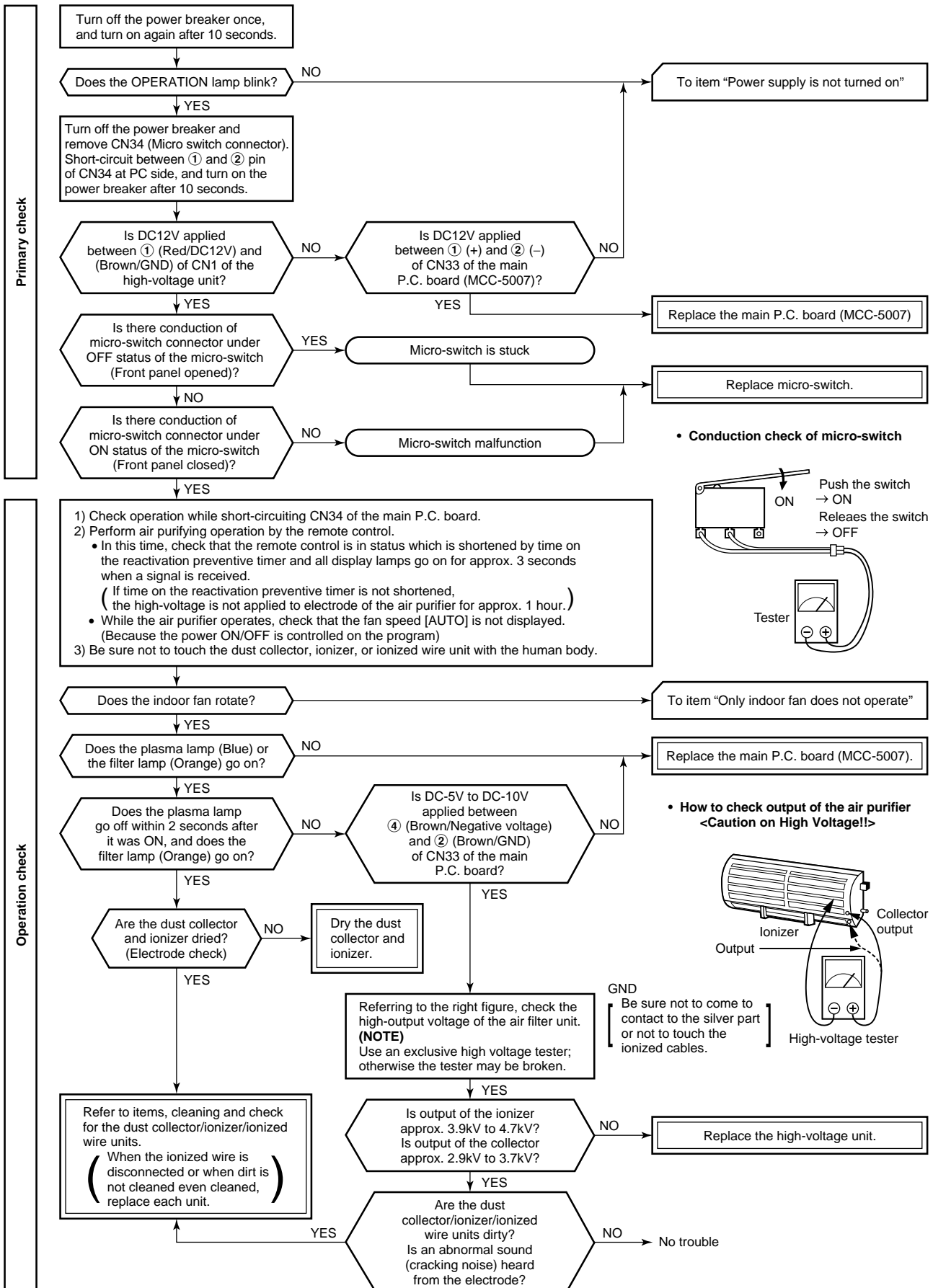


9-6-3. How to set/cancel self cleaning function

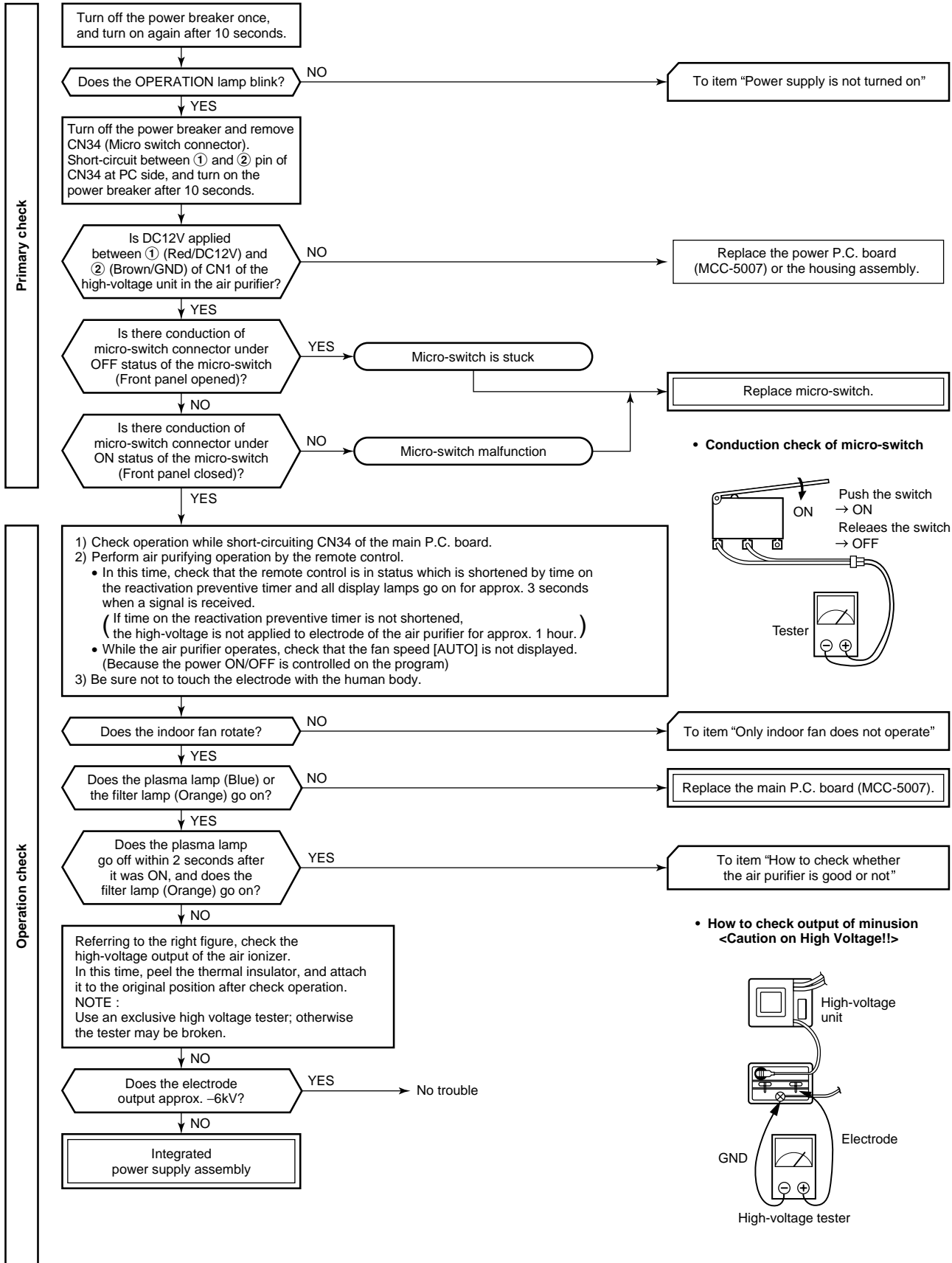
The self cleaning function is set from a factory. To cancel this function, should keep press the RESET switch on Indoor unit for 20 seconds till can hear the long combination sound and repeat the same procedure when need to set.

9-7. Troubleshooting for Air Purifier and Minus Ion

9-7-1. How to Check Whether the Air Purifier is Good or Not

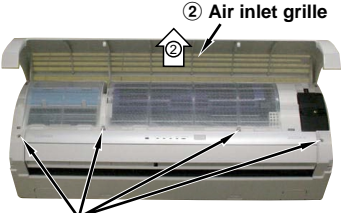


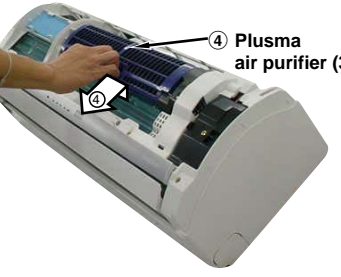
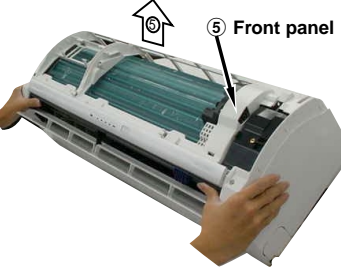


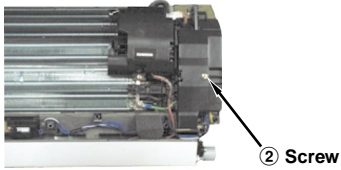
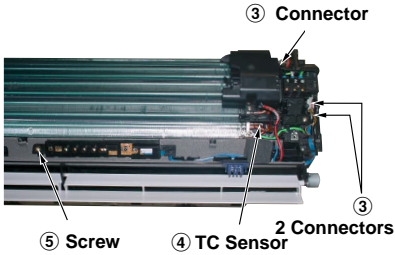
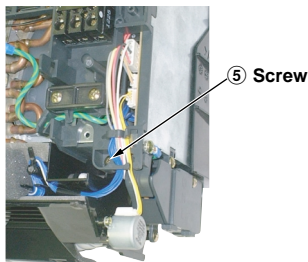
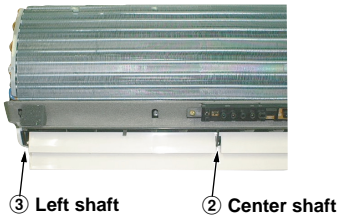
9-7-2. How to Check Whether the Minus Ion Generator is Good or Not

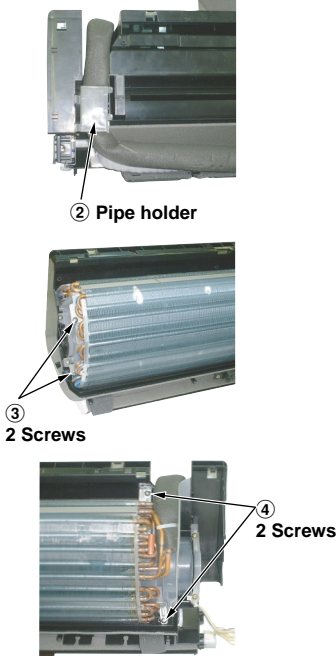
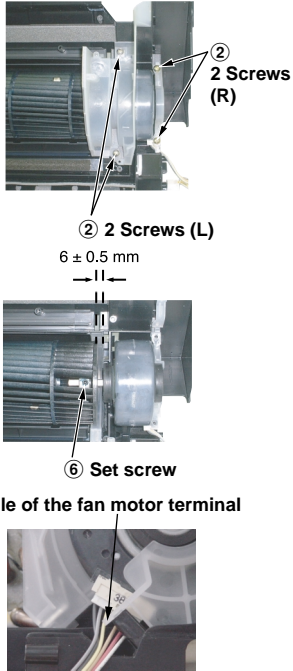
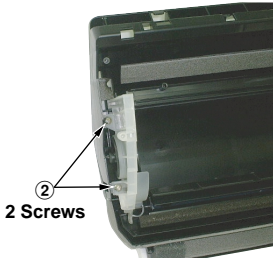


10. PART REPLACEMENT

10-1. Indoor Unit

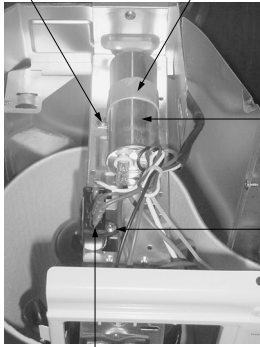
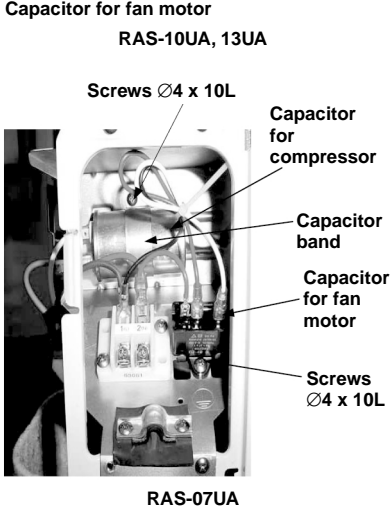
No.	Part name	Procedures	Remarks
①	Front panel	<p><u>How to remove the front panel</u></p> <ol style="list-style-type: none"> 1) Stop the operation of the air conditioner and turn off its main power supply. 2) Pull the air inlet grille toward you to open it and remove the air inlet grille. 3) Take off the right side of air filter. 4) Pull out the plasma air purifier. 5) Remove the 4 screws fixing the front panel before open the horizontal louver and then remove the front panel from back body by pulling it toward you. <p><u>How to mount the front panel</u></p> <p>Reverse step to remove the front panel. Push the front panel back in and make sure all hooks are locked.</p>	 <p>② Air inlet grille</p>  <p>④ 4 Screws</p>  <p>Air filter right</p>  <p>④ Plasma air purifier (3)</p>  <p>⑤ Front panel</p>

No.	Part name	Procedures	Remarks
②	Electrical part	<p><u>How to remove the electrical part</u></p> <ol style="list-style-type: none"> 1) Remove the front panel with procedure ①. 2) Remove the screw holding the electrical part cover. 3) Disconnect the 2 connectors (3P) for the fan motor, the connector (5P) for the louver motor from the P.C. board assembly and the connector (4P) for electrical supply. 4) Pull out the TC sensor from the sensor holder. 5) Remove the screw for the ground connection, remove the screw for the electrical part box and LED unit. Then remove the LED unit and the electrical part box from the main unit. <p><u>How to mount the electrical part</u></p> <ol style="list-style-type: none"> 1) To put back the electrical part box, lock it to the upper hook of the back body. 2) Tighten the screw on the electrical part box. 3) Connect the 3 connectors and arrange the wiring same as original condition and then tighten the screw from the LED unit to the back body. 4) Attach the TC sensor to the holder. 5) Tighten the screw for the ground connection. 6) Tighten the screw on the electrical part cover. 	  
③	Horizontal louver	<ol style="list-style-type: none"> 1) Remove the front panel following procedure ①. 2) Remove the center shaft of the horizontal louver from the back body. 3) Remove the left shaft from the back body. 4) Remove the horizontal louver from the back body. 	

No.	Part name	Procedures	Remarks
④	Heat exchanger	<ol style="list-style-type: none"> 1) Remove the front panel, electrical part following procedure ②. 2) Remove the pipe holder at the rear side of main unit. 3) Remove the 2 screws on the heat exchanger at the base bearing. 4) Remove the 2 screws on the heat exchanger at the 2 fixed plates (upper and lower) from the back body, and then pull out the upper side of the heat exchanger slowly. 	 <p>② Pipe holder</p> <p>③ 2 Screws</p> <p>④ 2 Screws</p>
⑤	Cross flow fan	<ol style="list-style-type: none"> 1) Remove the front panel, electrical part and the heat exchanger following procedure ④. 2) Remove the 2 screws on the band motor (L) and remove the 2 screws on the band motor (R) and then remove the cross flow fan. 3) Loosen the set screw of the cross flow fan then separate the fan and the fan motor. <p>Notice</p> <p>To assemble cross flow fan and fan motor to the unit, please turn the fan motor unit the center of its terminal meets the lowest point of band motor (R) (point A).</p> <p>Fix the cross flow fan with the set screw at the position where the gap between the back body and the right surface of the cross flow fan is 6 ± 0.5 mm.</p>	 <p>② 2 Screws (R)</p> <p>② 2 Screws (L)</p> <p>6 ± 0.5 mm</p> <p>⑥ Set screw</p> <p>Middle of the fan motor terminal</p>
⑥	Base bearing	<ol style="list-style-type: none"> 1) Remove the front panel, electrical part, heat exchanger and the cross flow fan following procedure ⑤. 2) Remove the 2 screws fixing the base bearing. 3) Remove the bearing from the base bearing. If the housing protrudes from the base bearing, put the housing in position and attach the bearing to the base bearing. 	 <p>② 2 Screws</p>

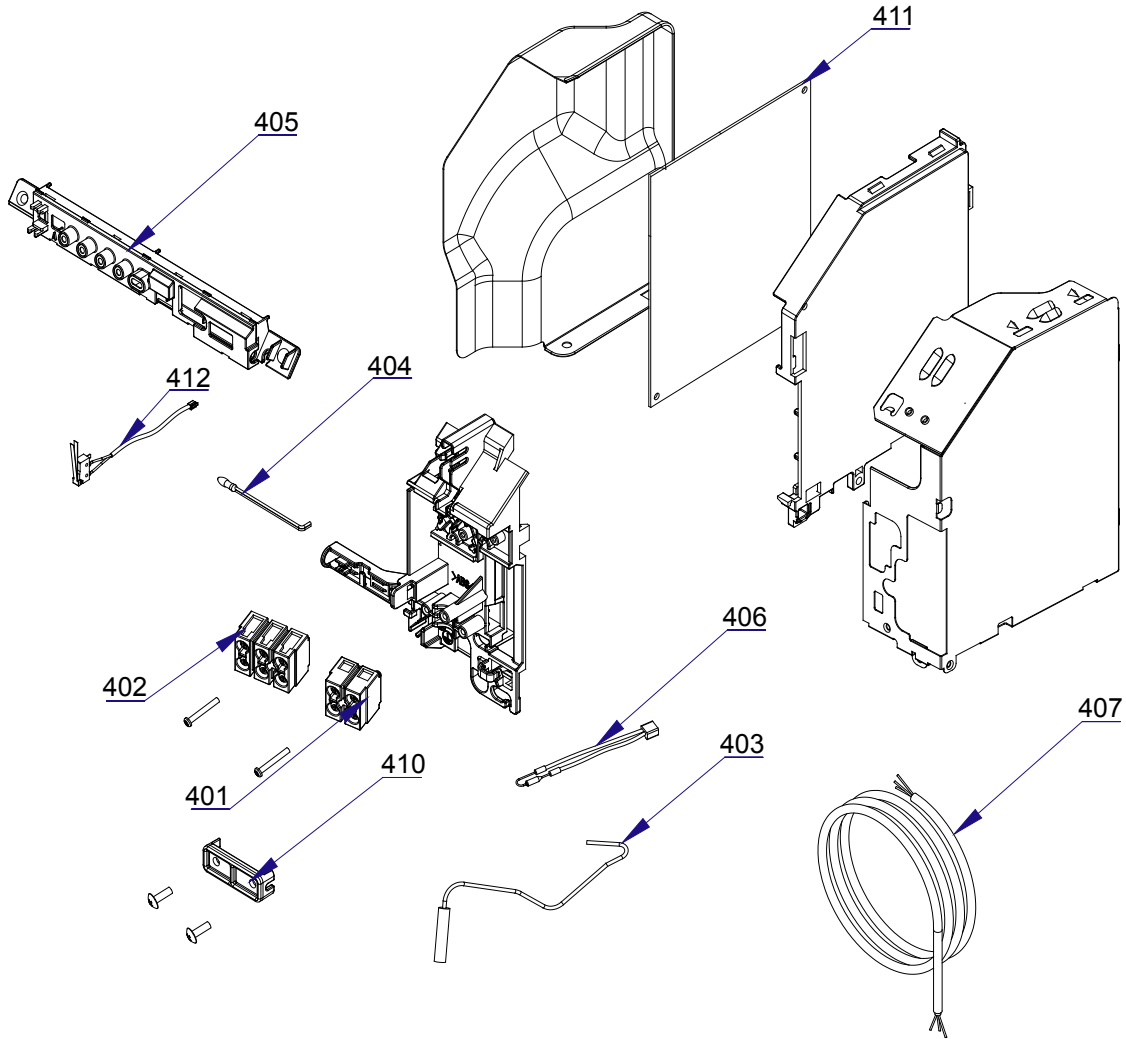
10-2. Outdoor Unit

No.	Part name	Procedures	Remarks
①	Common procedure	<ol style="list-style-type: none"> 1) Stop the operation of air-conditioner, and disconnect the power cord from the AC supply. 2) Remove packed valve cover and Electric parts cover. (3 Screws $\varnothing 4 \times 10L$) 3) Remove the cord clamp (2 Screws $\varnothing 4 \times 22L$) and disconnect the connecting cable. 4) Remove the upper cabinet (4 Screws $\varnothing 4 \times 10L$) Pulling out upward. 5) Remove the front cabinet. (3 Screws $\varnothing 4 \times 10L$) Pull the front right portion toward you, and remove it pulling out upward. 	<p>The 'Remarks' column contains three diagrams illustrating the disassembly steps:</p> <ul style="list-style-type: none"> Top Diagram: Shows the removal of the cord clamp (2 Screws $\varnothing 4 \times 22L$) and the electric parts cover (3 Screws $\varnothing 4 \times 10L$). The packed valve cover is also labeled. Middle Diagram: Shows the removal of the upper cabinet (4 Screws $\varnothing 4 \times 10L$) by pulling it out upward. Bottom Diagram: Shows the removal of the front cabinet (3 Screws $\varnothing 4 \times 10L$) by pulling the front right portion toward the viewer and then pulling it out upward.

No.	Part name	Procedures	Remarks
②	Capacitor for compressor	1) Perform the common procedure ①. 2) Remove the fixing screw and the capacitor band. (1 Screw $\varnothing 4 \times 8L$ for 10UA, 13UA) (1 Screw $\varnothing 4 \times 10L$ for 07UA) 3) Disconnect the lead wires.	 <p>Screws $\varnothing 4 \times 10L$</p> <p>Capacitor band</p> <p>Capacitor for compressor</p>
③	Capacitor for fan motor	1) Perform the common procedure ①. 2) Remove the fixing screw. (1 Screw $\varnothing 4 \times 10L$) 3) Disconnect the lead wires.	 <p>Capacitor for fan motor RAS-10UA, 13UA</p> <p>Screws $\varnothing 4 \times 10L$</p> <p>Capacitor for compressor</p> <p>Capacitor band</p> <p>Capacitor for fan motor</p> <p>Screws $\varnothing 4 \times 10L$</p> <p>RAS-07UA</p>

11. EXPLODED VIEWS AND PARTS LIST

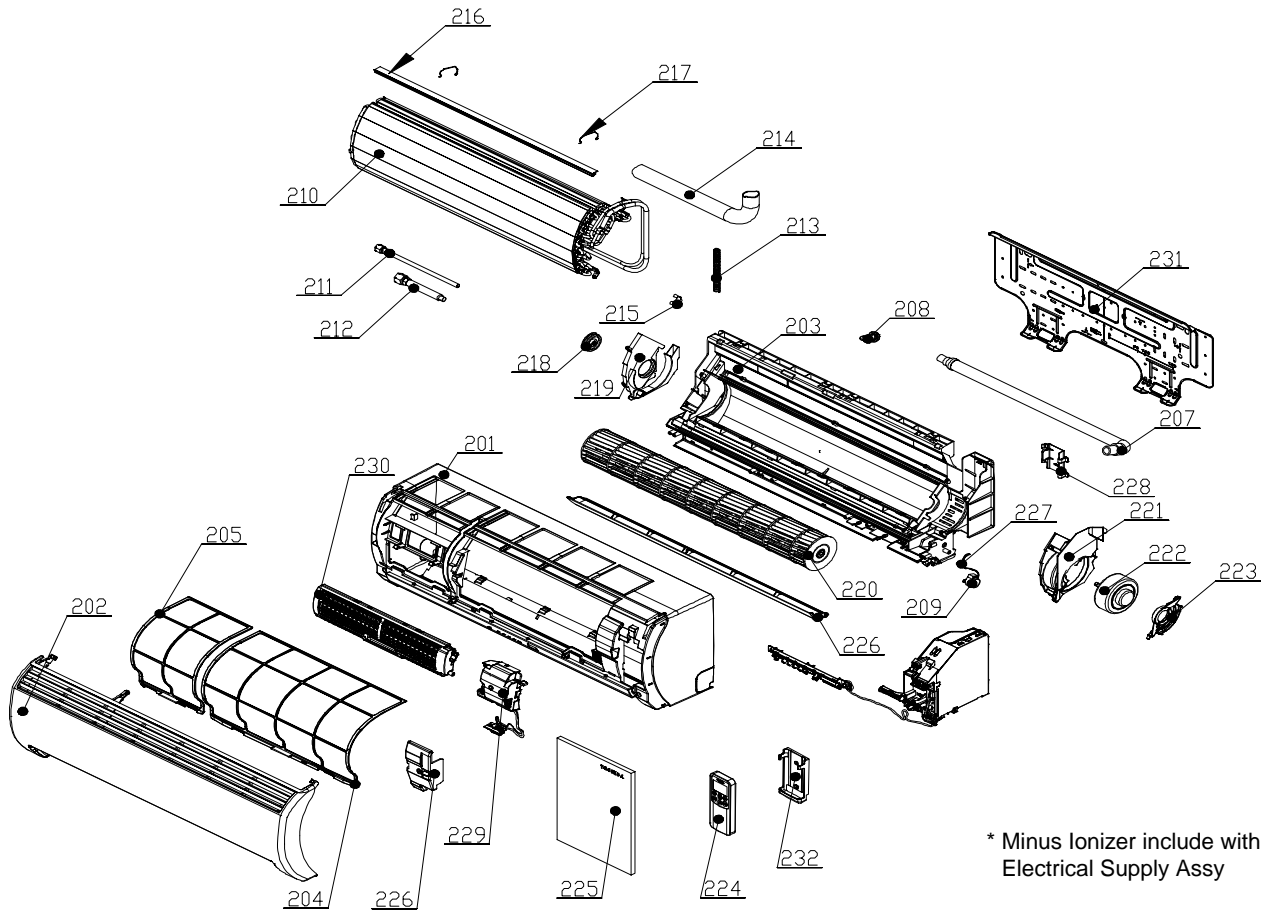
11-1. Indoor Unit (E-Parts Assy)



Location No.	Part No.	Description
401	43T60001	Terminal Block, 2P
402	43T60002	Terminal Block, 3P 3P AC300V, 20A
403	43T69004	TC Sensor 10kΩ 25°C
404	43T69005	Sensor, Thermostat 10kΩ 25°C
405	43T69416	P.C. Board ASSY, WRS-LED MCC-861
406	43T69364	Fuse, Temperature, 73°C
407	43T60355	POWER CORD

Location No.	Part No.	Description
410	43T62003	Cord Clamp
411	43T69408	P.C. Board (RAS-07NKD-E)
411	43T69409	P.C. Board (RAS-10NKD-E)
411	43T69410	P.C. Board (RAS-13NKD-E)
411	43T69411	P.C. Board (RAS-07NKHD-E)
411	43T69412	P.C. Board (RAS-10NKHD-E)
411	43T69413	P.C. Board (RAS-13NKHD-E)
412	43T51305	MICRO SWITCH

11-2. Indoor Unit

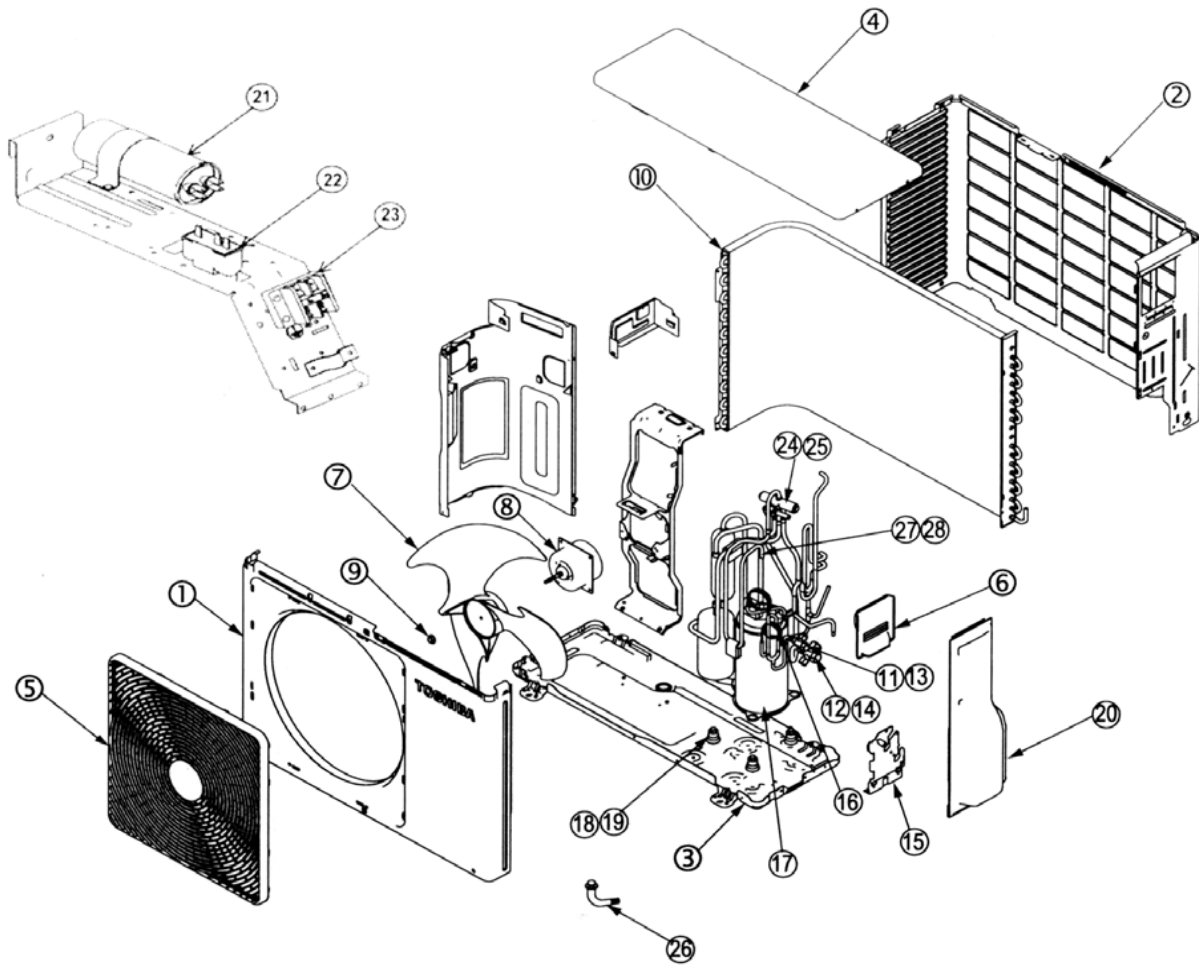


* Minus Ionizer include with Electrical Supply Assy

Location No.	Part No.	Description
201	43T00404	Front Panel Assy
202	43T09336	Inlet Grille Assy
203	43T03314	Back Body Assy
204	43T80309	Air Filter (R)
205	43T80310	Air Filter (L)
206	43T09328	Horizontal Louver
207	43T70002	Drain Hose
208	43T79301	Cap Drain
209	43T21321	Motor; Stepping
210	43T44343	Refrigeration Cycle Assy (For 07 Series)
210	43T44345	Refrigeration Cycle Assy (For 13 Series)
210	43T44348	Refrigeration Cycle Assy (For 10 Series)
211	43T47006	Pipe, Delivery Ø6.35
212	43T47005	Pipe, Suction Ø9.52 (For 07, 10 Series)
212	43T47016	Pipe, Suction Ø12.70 (For 13 Series)
213	43T49009	Spring
214	43T11301	Pipe Shield (For 07, 10 Series)

Location No.	Part No.	Description
214	43T11302	Pipe Shield (For 13 Series)
215	43T19302	Holder Sensor
216	43T49302	Plate of Eva Seal
217	43T49006	Holder For Plate
218	43T22002	Asm-M-Bearing
219	43T39301	Base, Bearing
220	43T20302	Cross Flow Fan
221	43T39302	Band Motor-L
222	43T21338	Motor, Fan
223	43T39303	Band Motor-R
224	43T69402	Wireless Remocon (For Heat pump model)
224	43T69403	Wireless Remocon (For Cooling model)
225	43T85462	Owner's Manual
226	43T62302	Terminal Cover
227	43T60317	Cord Motor Louver
228	43T07303	Holder Pipe
229	43T69406	Electrical Supply Assy
230	43T69407	Electrical Purifier Assy
231	43T82301	Plate; Installation
232	43T83003	Holder; Remote Controller

11-3. Outdoor Unit (RAS-13UAH-E3)

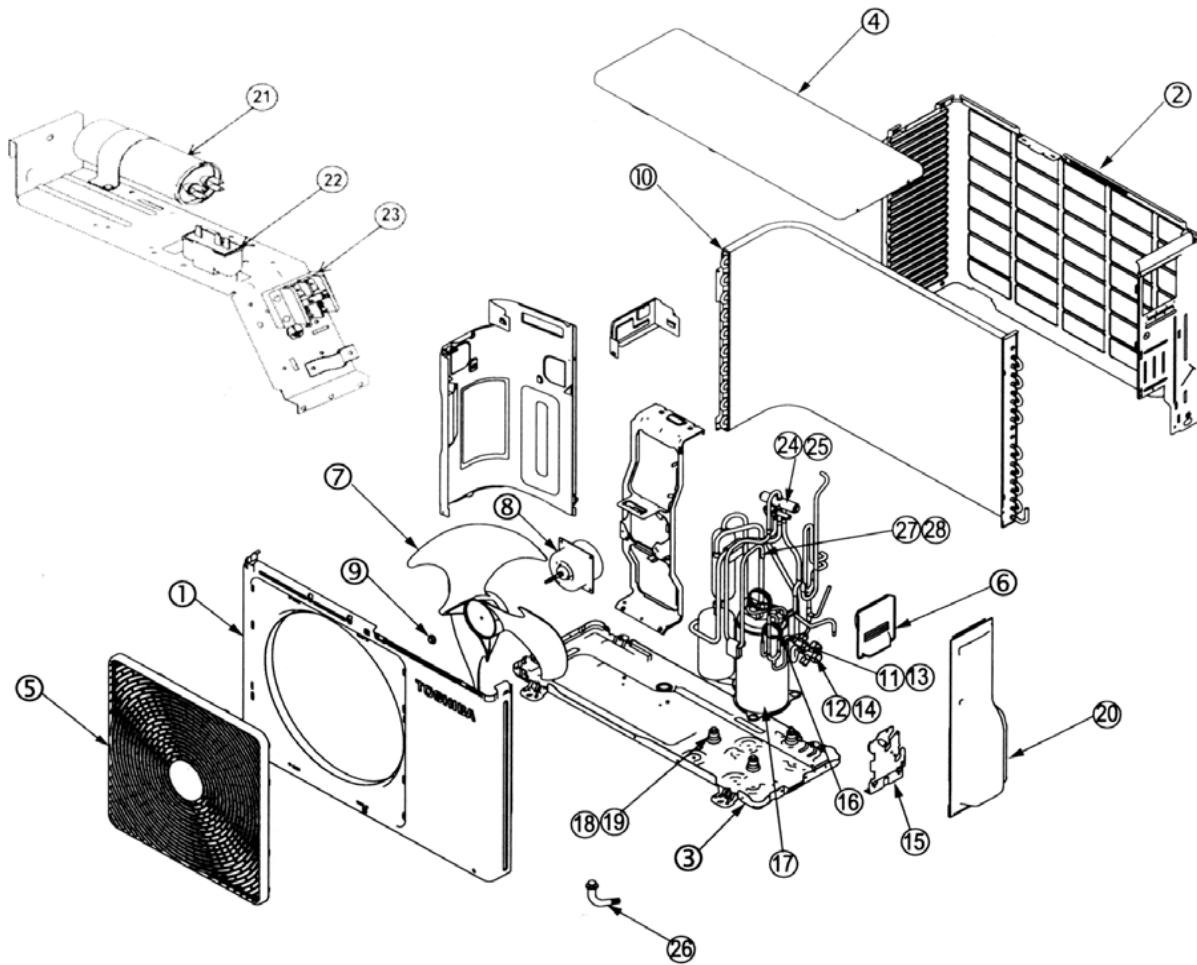


⑬ ⑲ : Capillary Tube

Location No.	Part No.	Description
01	43T00368	Front cabinet assembly
02	43T03306	Back cabinet assembly
03	43T42310	Base cabinet assembly
04	43T00396	Upper cabinet assembly
05	43T09318	Guard fan
06	43T62311	Electrical part cover
07	43T20307	Fan propeller
08	43T21308	Motor fan
09	43T47001	Nut flange
10	43T43342	Condenser assembly
11	43T46311	Valve packed 6.35 Dia
12	43T46019	Valve packed 12.7 Dia
13	43T47331	Bonnet, 6.35 Dia
14	43T47333	Bonnet, 12.7 Dia
15	43T03303	Fixing plate valve

Location No.	Part No.	Description
16	43T47011	Capillary Tube \varnothing 1.5ID
17	43T41764	Compressor (PH170T2-4L2)
18	43T47324	Bolt compressor(M6)
19	43T49008	Cushion rubber
20	43T52310	Packed valve cover assembly
21	43T55304	Capacitor Plastic film (35 μ F 370V)
22	43T55314	Capacitor Plastic film (1.5 μ F 450V)
23	43T60323	Terminal-4P
24	43T46319	4-Way Valve
25	43T46310	Coil V-4Way (AC220-240V 50Hz)
26	43T79305	Drain Nipple
27	43054306	Relay Overload
28	43T63001	Holder OI-Relay
29	43T47308	Capillary Tube 1.0 Dia

11-4. Outdoor Unit (RAS-10UAH-E3)

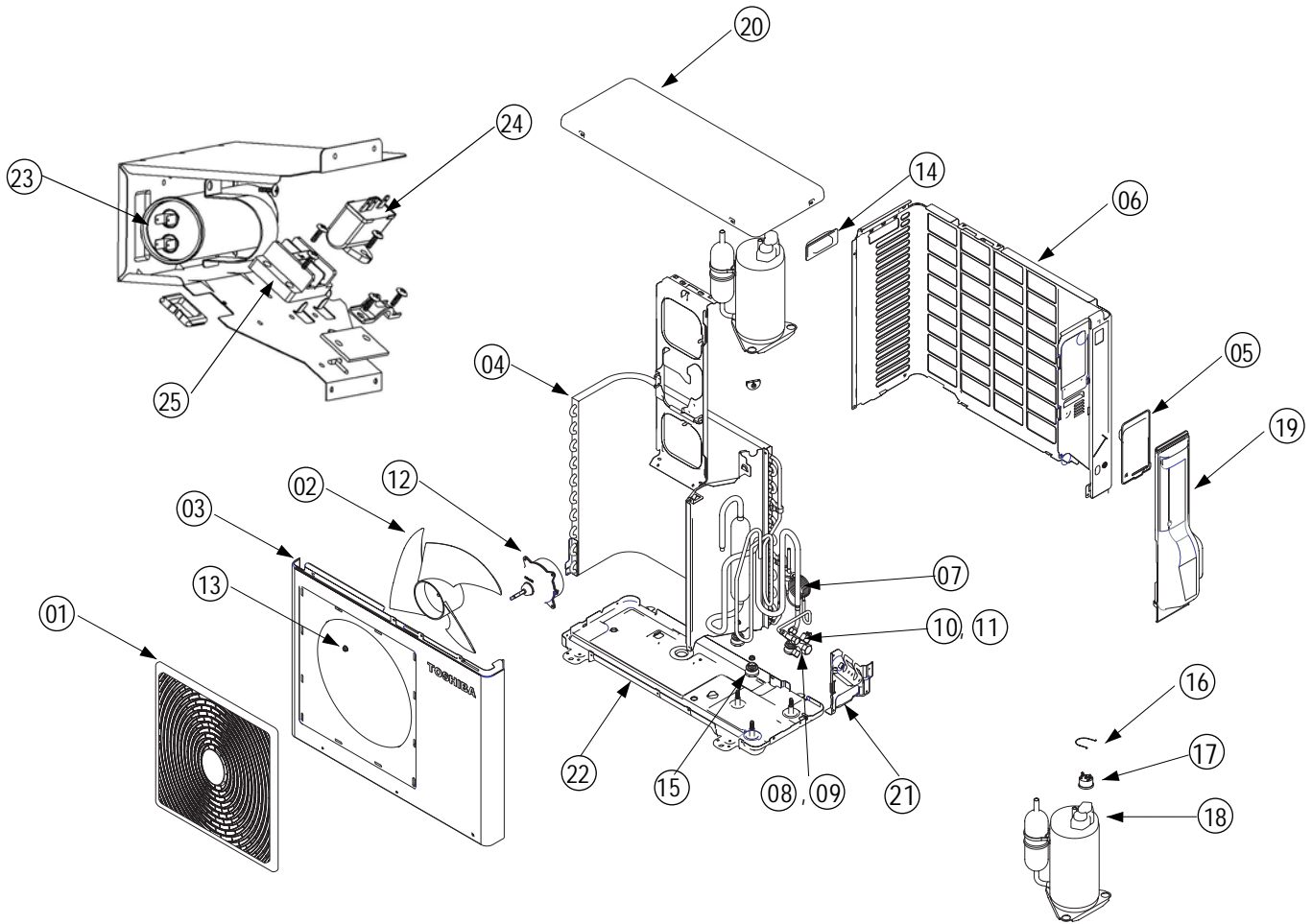


⑬ ⑲ : Capillary Tube

Location No.	Part No.	Description
01	43T00368	Front cabinet assembly
02	43T03308	Back cabinet assembly
03	43T42311	Base cabinet assembly
04	43T00395	Upper cabinet assembly
05	43T09318	Guard fan
06	43T62311	Electrical part cover
07	43T20307	Fan propeller
08	43T21300	Motor fan
09	43T47001	Nut flange
10	43T43345	Condenser assembly
11	43T46311	Valve packed 6.35 Dia
12	43T00347	Valve packed 9.52 Dia
13	43T47331	Bonnet, 6.35 Dia
14	43T47332	Bonnet, 12.7 Dia
15	43T03303	Fixing plate valve

Location No.	Part No.	Description
16	43T47011	Capillary Tube $\varnothing 1.5ID$
17	43T41400	Compressor (PH120T1-4C)
18	43T47325	Bolt compressor(M6)
19	43T49001	Cushion rubber
20	43T52310	Packed valve cover assembly
21	43T55305	Capacitor Plastic film (25 μ F 370V)
22	43T55314	Capacitor Plastic film (1.5 μ F 450V)
23	43T60323	Terminal-4P
24	43T46321	4-Way Valve
25	43T49307	Solenoïd Coil
26	43T79305	Drain Nipple
27	43054403	Relay Overload
28	43T63001	Holder OI-Relay

11-4. Outdoor Unit (RAS-07UAH-E3)

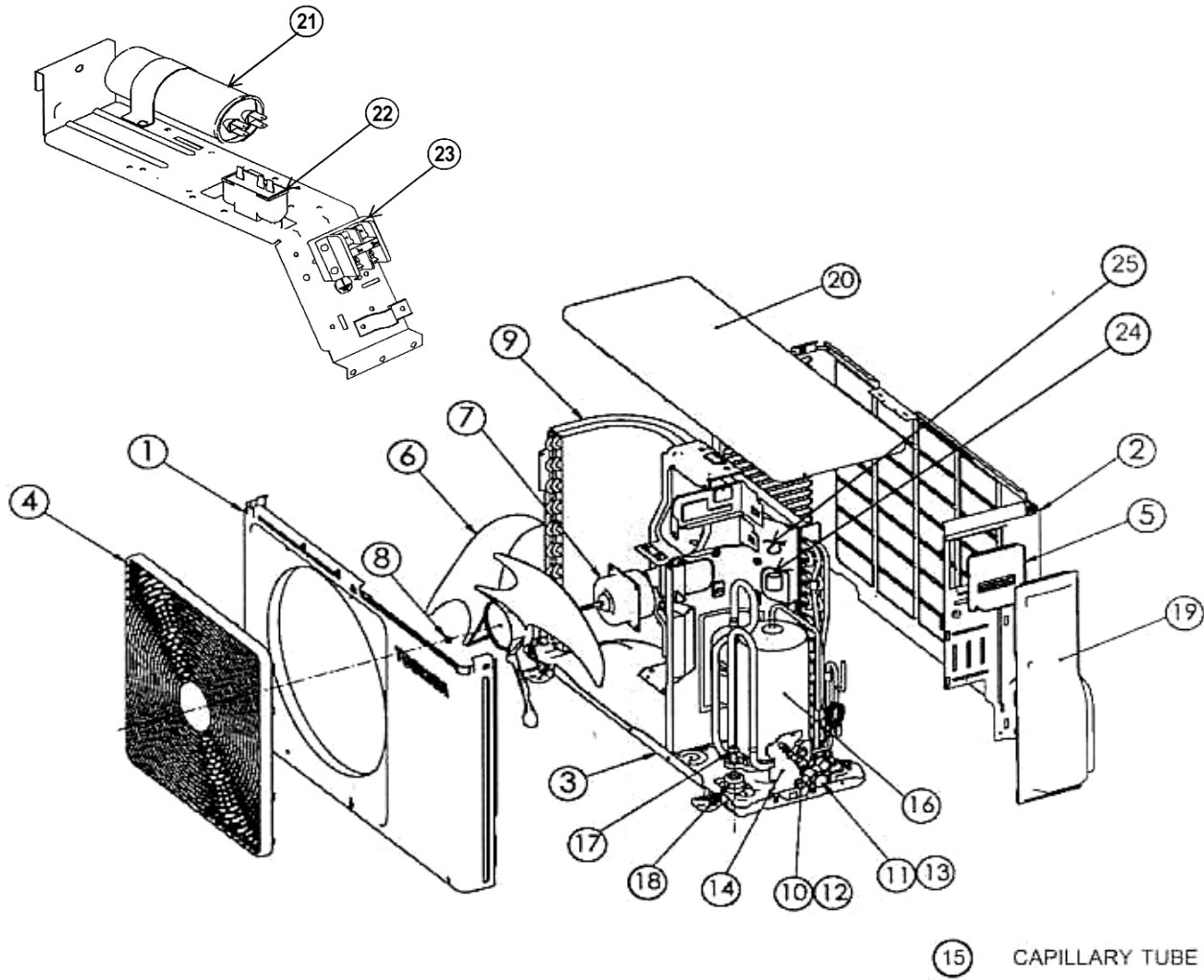


⑦ : CAPILLARY TUBE

Location No.	Part No.	Description
01	43T19313	Guard, Fan
02	43T20306	Fan, Propeller
03	43T00398	Front Cabinet Coating Assembly
04	43T43350	Condenser Assembly
05	43T62304	Electric Parts Cover
06	43T00397	Back Cabiinet Coating Assembly
07	43T47308	Capillary Tube 1.0 DIA
08	43T00347	Valve, Packed 9.52 DIA
09	43T47332	Bonnet, 9.52 DIA
10	43T46311	Valve, Packed 6.35 DIA
11	43T47331	Bonnet, 6.35 DIA
12	43T21320	Motor, Fan
13	43T47001	Nut, Flange
14	43T19312	Handle

Location No.	Part No.	Description
15	43T49001	Cushion, Rubber
16	43T63001	Holder OI-Relay
17	43T54302	Relay Overload
18	43T41304	Compressor (PH80T1-4C)
19	43T62305	Packed Valve Cover
20	43T00394	Upper Cabinet Coating Assembly
21	43T63301	Fixing Plate Valve
22	43T42314	Base Coating Assembly
23	43T55305	Capacitor, Plastic Film, 25 μ F 370V
24	43T55314	Capacitor, Plastic Film, 1.5 μ F 450V
25	43T60323	Terminal-4P
26	43T46312	4Way-Valve
27	43T46316	Coil Valve 4Way
28	43T79305	Drain Nipply

11-5. Outdoor Unit (RAS-13UA-E3)

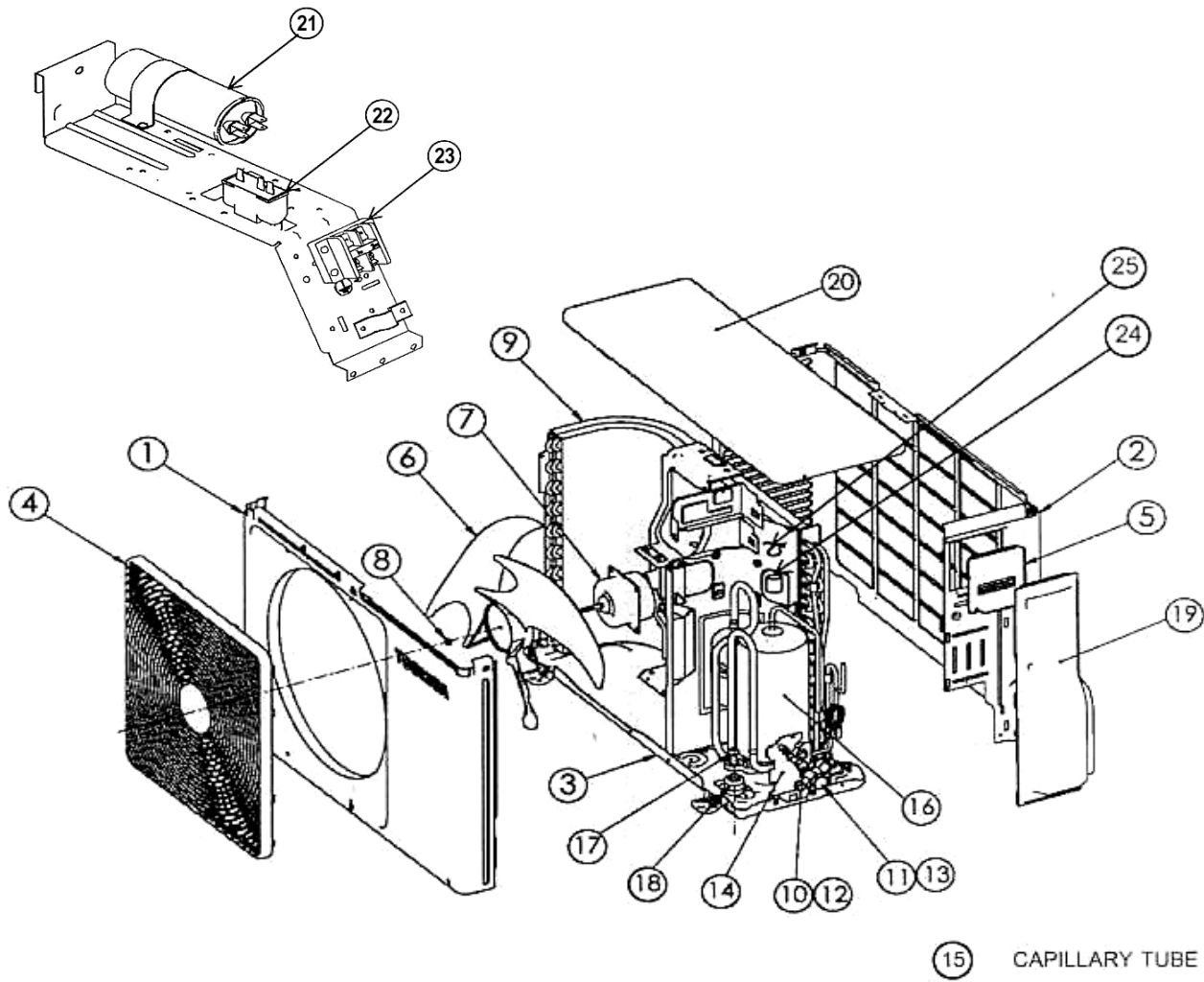


(15) CAPILLARY TUBE

Location No.	Part No.	Description
01	43T00368	Front cabinet assembly
02	43T03306	Back cabinet assembly
03	43T42309	Base coat assembly
04	43T09318	Guard Fan
05	43T62311	Electric part cover
06	43T20307	Fan propeller
07	43T21323	Motor fan
08	43T47001	Nut flange
09	43T41351	Condenser assembly
10	43T46311	Valve packed 6.35 Dia
11	43T46019	Valve packed 12.7 Dia
12	43T47331	Bonnet 6.35 Dia

Location No.	Part No.	Description
13	43T47333	Bonnet 12.7 Dia
14	43T63303	Finxing plate valve
15	43T47014	Capillary tube 1.7 Dia
16	43T41348	Compressor (PH225X2C-4FT)
17	43T47324	Bolt compressor (M6)
18	43T49008	Cushion rubber
19	43T52310	Packed valve cover assembly
20	43T00396	Upper cabinet assembly
21	43T55304	MF-Capacitor (35 μ F 370V)
22	43T55314	Capacitor, Plastic film (1.5 μ F 450V)
23	43T60322	Terminal-2P

11-6. Outdoor Unit (RAS-10UA-E3)

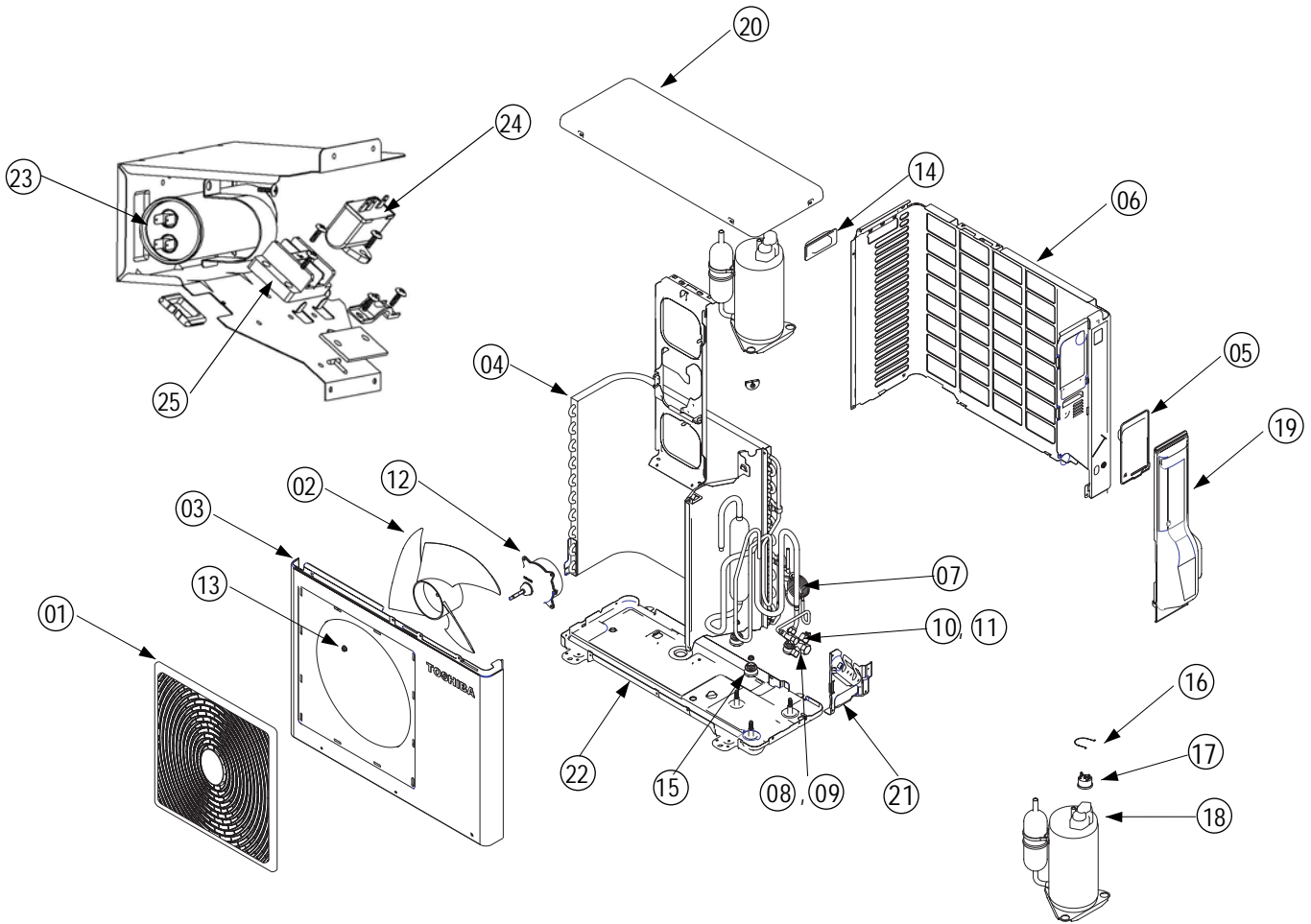


(15) CAPILLARY TUBE

Location No.	Part No.	Description
01	43T00368	Front cabinet assembly
02	43T03308	Back cabinet assembly
03	43T42311	Base coat assembly
04	43T09318	Guard Fan
05	43T62311	Electric part cover
06	43T20307	Fan propeller
07	43T21320	Motor fan
08	43T47001	Nut flange
09	43T41352	Condenser assembly
10	43T46311	Valve packed 6.35 Dia
11	43T00347	Valve packed 9.52 Dia
12	43T47331	Bonnet 6.35 Dia
13	43T47332	Bonnet 9.52 Dia

Location No.	Part No.	Description
14	43T63303	Finxing plate valve
15	43T47011	Capillary tube 1.5 Dia
16	43T41339	Compressor (PH102T1-4CH)
17	43T47325	Bolt compressor (M6)
18	43T49001	Cushion rubber
19	43T52310	Packed valve cover assembly
20	43T00395	Upper cabinet assembly
21	43T55305	MF-Capacitor (35 μ F 370V)
22	43T55314	Capacitor, Plastic film (1.5 μ F 450V)
23	43T60322	Terminal-2P
24	43T54303	Relay Overload
25	43T63001	Holder OI-Relay

11-7. Outdoor Unit (RAS-07UA-E3)



⑦ : CAPILLARY TUBE

Location No.	Part No.	Description
01	43T19313	Guard, Fan
02	43T20306	Fan, Propeller
03	43T00398	Front Cabinet Coating Assembly
04	43T43340	Condenser Assembly
05	43T62304	Electric Parts Cover
06	43T00397	Back Cabinet Coating Assembly
07	43T47008	Capillary Tube 1.2 DIA
08	43T00347	Valve, Packed 9.52 DIA
09	43T47332	Bonnet, 9.52 DIA
10	43T46311	Valve, Packed 6.35 DIA
11	43T47331	Bonnet, 6.35 DIA
12	43T21320	Motor, Fan
13	43T47001	Nut, Flange

Location No.	Part No.	Description
14	43T19312	Handle
15	43T49001	Cushion, Rubber
16	43T63001	Holder OI-Relay
17	43T54302	Relay Overload
18	43T41304	Compressor, PH80T1-4C
19	43T62305	Packed Valve Cover
20	43T00394	Upper Cabinet Coating Assembly
21	43T63301	Fixing Plate Valve
22	43T42313	Base Coating Assembly
23	43T55310	Capacitor, Plastic Film, 15 μ F 370V
24	43T55314	Capacitor, Plastic Film, 1.5 μ F 450V
25	43T60322	Terminal-2P

TOSHIBA CARRIER (THAILAND) CO., LTD.

144/9 MOO 5, BANGKADI INDUSTRIAL PARK, TIVANON ROAD, TAMBOL BANGKADI,
AMPHUR MUANG, PATHUMTHANI 12000, THAILAND.