

# User manual for DV without control system

Air handling unit

Manual version 1.01.13

Part number of this manual 90925371

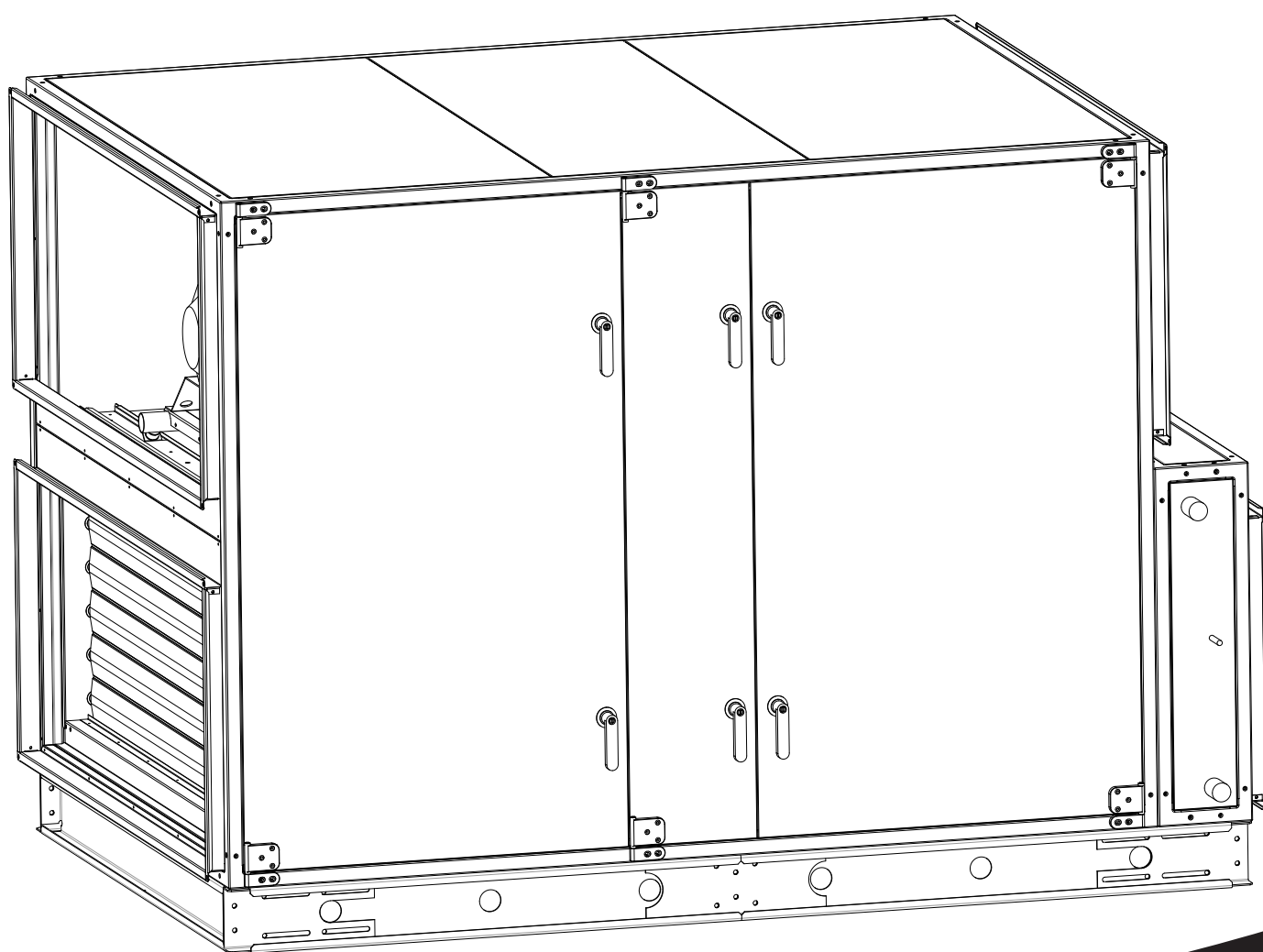

## Detailed table of contents on the following pages

### General description

- a. Manufacturer
- b. Name of machines
- c. Declaration of conformity - example
- d. General descriptions, dangers and warnings
- e. Drawings, diagrams, guides and instructions for use, maintenance, repairs
- f. Employees in charge of operation/control/maintenance
- g. Intended use and applications
- h. Unintended use and misuse – inappropriate applications for the machine

### Installation

- i. Instructions for unloading on the site, installation and connection
- j. Installation and assembly instructions for reduction of noise and vibrations

### Start-up, adjustments and operation

- k. Start-up, adjustments, use and commissioning
- l. Residual risks that remain
- m. Instructions on the protective measures during repair and maintenance
- n. Tools which may be fitted to the machinery

### Machine stability

- o. Stability during use, transportation, assembly, dismantling when out of service
- p. Machinery where these are regularly to be transported

### Breakdown

- q. Operating method in the event of breakdown. Safe restart.

### Maintenance

- r. Adjustment and maintenance operations
- s. Adjustments and maintenance to be carried out safely
- t. Spare parts to be used, when these affect health and safety

### Noise

- u. Information on airborne noise emissions exceeding 70 dB(A)

### Annexes

1. Declaration of conformity with production number (in separate cover)
2. Technical data – unique data for every unit (in separate cover)
3. Spare part list (in separate cover)
4. Assembly of base frame – height 150 mm for unit sizes 10 – 40
5. Assembly of base frame – height 150 mm for unit sizes 50 – 150
6. Assembly of base frame – height 250 mm for unit sizes 10 – 40
7. Assembly of base frame – height 250 mm for unit sizes 50 – 150
8. Installation of steel roof in the sizes 10-150
9. Rotary exchanger – speed control and assembly of divided rotor
10. Reversible heat pump unit DVU-HP (in separate cover, if heat pump was delivered)
11. Menu for internal controller in the heat pump unit - DVU-HP (in separate cover)
12. Connection of fan motor and set-up manual for Danfoss VLT FC101 frequency converter
13. Commissioning protocol – proposal (in separate cover)

This manual has part number 90925371

# Contents

<b>A. MANUFACTURER</b> .....	9
<b>B. NAME OF MACHINES</b> .....	9
<b>C. DECLARATION OF CONFORMITY - EXAMPLE</b> .....	10
<b>D. GENERAL DESCRIPTIONS, DANGERS AND WARNINGS</b> .....	11
d.1 Overview via pictograms on the inspection side of the unit.....	11
d.1.1 Where are pictograms placed on the units .....	12
d.1.2 Label with production number.....	13
d.1.3 Pictogram on a door for a fan in a DV unit.....	13
d.1.4 Pictograms for all available functions in the units.....	14
d.1.5 Pictograms about warnings and dangers on the units.....	16
d.2 Data about the unit according to cards and labels in and on the unit.....	17
d.2.1 Machine card with unique data on every unit .....	17
d. 3 Dimensions of the units .....	18
d.4 About operation and control.....	18
d. 5 Warnings about dangers .....	18
<b>E. DRAWINGS, DIAGRAMS, GUIDES AND INSTRUCTIONS FOR THE USE, MAINTENANCE AND REPAIR</b> .....	18
<b>F. EMPLOYEES IN CHARGE OF OPERATION/CONTROL/MAINTENANCE</b> .....	19
<b>G. INTENDED USE AND RANGE OF APPLICATIONS</b> .....	19
<b>H. UNINTENDED USE AND MISUSE – INAPPROPRIATE APPLICATIONS FOR THE MACHINE</b> .....	19
h.1 Air handling unit in operation .....	19
<b>I. INSTRUCTIONS FOR UNLOADING ON THE SITE AS WELL AS INSTALLATION AND CONNECTION</b> .....	20
i.1. Unloading on the site.....	20
i.1.1 Unloading by fork-lift truck.....	20
i.1.2 Unloading by crane .....	20
i.1.3 Transport of unit without base frame on the site .....	20
i.1.4 Lifting a unit with straps .....	20
i.1.5 Lifting a unit with preinstalled brackets on the base frame for lifting .....	21
i.1.6 Roof unit with bitumen roof .....	21

i.1.7 Roof unit with steel roof.....	22
i.1.8 Pre-assembly storage .....	22
i.1.9 Tilt less than 30° during transportation of the section with heat pump – DVU .....	22
i.2. Installation - mechanical .....	22
i.2.1 Free area in front of and above the unit.....	22
i.2.2 Supporting surface .....	22
i.2.3 Adjustable feet under legs or base frame and transport of sections.....	22
i.2.4 Base frame assembly.....	23
i.2.5 Base frames for outdoor units .....	24
i.2.6 Installation on the site of unit sections at the base frame when sections are delivered on pallets .....	24
i.2.7 Joining the AHU sections .....	26
i.2.8 Fitting the ductwork.....	26
i.2.9 Risk of stack effect by vertical ducts and wind pressure on louvers .....	26
i.2.10 Remove transport brackets – when spring mounts are installed .....	27
i.2.10.1 Impeller diameters 220 – 560 mm .....	27
i.2.10.2 Impeller diameters 630 – 1.000 mm .....	28
i.2.11 Refitting of guards.....	29
i.3. Installation - electrical.....	29
i.3.1 Necessary overvoltage protection device, that leads lightning overvoltage to an earth lead on a safe way. ....	29
i.4 Installation – Pipes for water – hot and chilled, valves and drains .....	29
i.4.1 Description .....	29
i.4.2 Pipe connections .....	30
i.4.3 Possibility of extracting components from the unit.....	30
i.4.4 Pipe connections to batteries .....	30
i.4.4.1 Heating coils.....	30
i.4.4.2 Cooling coils .....	30
i.4.4.3 Rigid pipe mounting brackets for valves, circulation pumps and pipe system .....	30
i.4.4.3.1 Pipe connection to heating coils.....	30
i.4.4.3.2 Pipe connection to cooling coils for chilled water .....	31
i.4.5 Draining condensate water.....	32
i.4.6 Draining condensate water from plate heat exchanger.....	32
i.4.7 Draining condensate water from cooling battery.....	32

## **J. INSTALLATION AND ASSEMBLY INSTRUCTIONS FOR REDUCTION OF NOISE AND VIBRATION EMISSIONS ..... 33**

## **K. INSTRUCTIONS FOR PUTTING INTO SERVICE, ADJUSTMENTS, USE AND COMMISSIONING. .... 33**

k.1 Print-outs on paper.....	33
k.2 Electronic media .....	33
k.3 Documentation is available for download from <a href="https://techdoc.systemair.dk">https://techdoc.systemair.dk</a> .....	33
k.4 Start-up by installer .....	33

k.4.1 Checklist, relevant values .....	33
k.4.1.1 Checklist prior to start-up .....	34
k.4.1.2 Switch on power.....	34
k.5 Description of functions .....	34
k.5.1 Heating coil for hot water prepared for temperature sensor (frost protection).....	34
k.5.2 DX cooling .....	34
k.5.3 Circulation pump, heating.....	34
k.5.4 Electrical heater battery .....	34
k.5.4.1 Control of heating capacity connected to unit without Systemair control system .....	34
k.5.5 Speed control of fans.....	35
k.5.5.1 Frequency converters inside the unit are IP 20.....	35
k.5.5.2 Frequency converters on the unit are IP 54.....	35
k.5.6 Pressure transmitters .....	35
k.5.7 Damper motors .....	35
k.5.8 Filter guards .....	35
k.6 Commissioning .....	35

**L. INFORMATION ABOUT THE *RESIDUAL RISKS* THAT REMAIN DESPITE THE INHERENT SAFE DESIGN MEASURES, SAFEGUARDING AND COMPLEMENTARY PROTECTIVE MEASURES ADOPTED. ....**

.....	35
l.1 Unit casing.....	35
l.1.1. Design of the machine to make transport safe .....	35
l.2 Common for all unit sections.....	36
l.2.1 Risk caused by surfaces, edges and corners .....	36
l.3 Common for all unit sections by insufficient lighting .....	36
l.3.1 Risk caused by insufficient lighting inside sections.....	36
l.4 Dampers type DVA – DVB – DVM – DVP – Bypass dampers in DVQ.....	36
l.4.1 Risk caused by maintenance and cleaning of dampers.....	36
l.5 Attenuators type DVD.....	36
l.5.1 Risk caused by maintenance and cleaning of attenuators .....	37
l.6 Filters type DVG – DVF .....	37
l.6.1 Risk caused by missing change of filters .....	37
l.6.2 Risk caused by the execution of filter change .....	37
l.7 Plug fans type DVE.....	37
l.7.1 Risk caused by lightning strike .....	37
l.7.2. Risk caused by permanent magnet motor .....	38
l.7.3 Risk of rotating impeller caused by stack effect (chimney effect). .....	38
l.8 Batteries for heating and cooling type DVR – DVH – DVK – DVU .....	38
l.8.1 Extreme temperatures - heating .....	38
l.8.2 Extreme temperatures - cooling.....	38
l.9 Heat pump units type DVU.....	39
l.9.1 Risk of high temperature .....	39
l.9.2 Risk caused by lightning strike .....	39

<b>M. INSTRUCTIONS ON THE PROTECTIVE MEASURES TO BE TAKEN BY ALL SERVICE TECHNICIANS DURING REPAIR AND MAINTENANCE .....</b>	<b>39</b>
<b>N. THE ESSENTIAL CHARACTERISTICS OF TOOLS WHICH MAY BE FITTED TO THE MACHINERY .....</b>	<b>39</b>
<b>O. THE CONDITIONS OF STABILITY DURING USE, TRANSPORTATION, ASSEMBLY, DISMANTLING WHEN OUT OF SERVICE.....</b>	<b>40</b>
o.1 Installed reliable to avoid units to be tilted or moved by the any storm. ....	40
o.2 Transport of section with heat pump unit.....	40
o.3 Disposal of the heat pump system - type DVU .....	40
o.4 General disassembly – sharp edges .....	40
<b>P. INSTRUCTIONS FOR MACHINERY WHERE THESE ARE REGULARLY TO BE TRANSPORTED .....</b>	<b>40</b>
<b>Q. THE OPERATING METHOD TO BE FOLLOWED IN THE EVENT OF BREAKDOWN. SAFE RESTART.....</b>	<b>40</b>
<b>R. ADJUSTMENT AND MAINTENANCE OPERATIONS.....</b>	<b>41</b>
r.1 Shutdown of the unit to a safe state. ....	41
r.2 Recommended maintenance intervals .....	42
r.3. Filters – always replace filters with new filters with the same characteristics to maintain SFP value .....	44
r.3.1 Bag filters – the number of filters and the sizes of the frames .....	45
r.3.2 Panel filters – the number of filters and the sizes of the frames.....	46
r.3.3 Bag filters .....	47
r.3.4 Panel filters .....	47
r. 4 Other functions to maintain.....	47
r. 4.1 The unit .....	47
r. 4.2 Dampers .....	48
r. 4.3 Rotary heat exchanger DVC .....	48
r. 4.3.1 Rotor .....	48
r. 4.3.2 Motor and belt drive .....	49
r. 4.4 Cross flow and counter flow exchanger.....	49
r. 4.4.1 By-pass damper.....	49
r. 4.4.2 Condensate water drain .....	49
r. 4.5 Run-around heat exchanger DVR.....	50
r. 4.5.1 Pump and pressure expansion .....	50
r. 4.5.2 Condensate water drain .....	50
r. 4.6 Heating coil DVH, cooling coil DVK and change over coil DVHK .....	50
r. 4.6.1 Heating battery .....	50
r. 4.6.2 Cooling battery .....	50

r. 4.6.3 Electric heating battery.....	51
r. 4.7 Plug fans DVE.....	51
r. 4.7.1 Motor .....	51
r. 4.8 Silencer DVD .....	51
.....	51
r. 4.9 Outdoor air section DVY .....	52
r. 4.10 Heat pump unit – DVU-HP .....	53

**S. INSTRUCTIONS DESIGNED TO ENABLE ADJUSTMENT AND MAINTENANCE TO BE CARRIED OUT SAFELY, INCLUDING THE PROTECTIVE MEASURES THAT SHOULD BE TAKEN DURING THESE OPERATIONS ..... 54**

s.1. Protective measures and additional protective measures.....	54
s.1.1 Necessary protection measures prior to start-up. ....	54
s.1.1.1 Design of protection measures .....	54
s.1.1.2 Configuration of frequency converters with installed guard .....	54
s.1.2 Safe adjustment and maintenance .....	54
s.1.3 Personal protective equipment for maintenance staff – health and safety .....	55

**T. THE SPECIFICATIONS OF THE SPARE PARTS TO BE USED, WHEN THESE AFFECT THE HEALTH AND SAFETY OF OPERATORS..... 55**

t.1 Spare parts - Mechanical .....	55
t.2 Spare parts - Electrical .....	55

**U. INFORMATION ON AIRBORNE NOISE EMISSIONS EXCEEDING 70 DB(A)..... 55**

**ANNEX FOR THE USER MANUAL ..... 57**

**OVERVIEW OF ANNEXES..... 58**

**ANNEX 1 DECLARATION OF CONFORMITY WITH UNIQUE PRODUCTION NUMBER..... 58**

**ANNEX 2 TECHNICAL DATA – UNIQUE DATA FOR EVERY UNIT ..... 58**

**ANNEX 3 SPARE PART LISTS ..... 58**

**ANNEX 4 ASSEMBLE BASE FRAMES – HEIGHT 150 MM FOR UNITS IN THE SIZES 10-40 58**

**ANNEX 5 ASSEMBLE BASE FRAMES – HEIGHT 150 MM FOR UNITS IN THE SIZES 50-150  
..... 58**

**ANNEX 6 ASSEMBLE BASE FRAMES – HEIGHT 250 MM FOR UNITS IN THE SIZES 10-40 58**

<b>ANNEX 7 ASSEMBLE BASE FRAMES – HEIGHT 250 MM FOR UNITS IN THE SIZES 50-150</b>	<b>58</b>
<b>ANNEX 8 INSTALLATION OF STEEL ROOF IN THE SIZES 10-150</b>	<b>58</b>
<b>ANNEX 9 ROTARY EXCHANGER – SPEED CONTROL AND ASSEMBLY OF DIVIDED ROTOR</b>	<b>58</b>
<b>ANNEX 10 HEAT PUMP UNIT – DVU-HP</b>	<b>58</b>
<b>ANNEX 11 MENU FOR INTERNAL CONTROLLER IN THE HEAT PUMP UNIT</b>	<b>58</b>
<b>ANNEX 12 CONNECTION OF FAN MOTOR AND SET-UP MANUAL FOR DANFOSS VLT FC101 FREQUENCY CONVERTER</b>	<b>58</b>
<b>ANNEX 13 COMMISSIONING PROTOCOL – PROPOSAL (RECEIPT FOR HAND-OVER)</b>	<b>59</b>
<b>Annex 4. Assemble base frames – height 150 mm for units sizes 10-40</b>	<b>4–1</b>
4.1 Base frame length 720 – 2420 [mm] Unit size 10-40	4–2
4.2 Base frame length 2420 – 4590 [mm] Unit size 10-40	4–3
4.3 Base frame length 4590 – 6200 [mm] Unit size 10-40	4–4
<b>Annex 5. Assemble base frames – height 150 mm for units sizes 50-150</b>	<b>5–1</b>
5.1 Base frame length 720 – 2420 [mm] Unit size 50-DV150	5–2
5.2 Base frame length 2420 – 4590 [mm] Unit size 50-150	5–3
5.3 Base frame length 4590 – 6200 [mm] Unit size 50-150	5–4
<b>Annex 6. Assemble base frames – height 250 mm for units sizes 10-40</b>	<b>6–1</b>
6.1 Base frame length 720 – 2420 [mm] Unit size 10-40	6–2
6.2 Base frame length 2420 – 4590 [mm] Unit size 10-40	6–3
6.3 Base frame length 4590 – 6200 [mm] Unit size 10-40	6–4
<b>Annex 7. Assemble base frames – height 250 mm for units sizes 50-150</b>	<b>7–1</b>
7.1 Base frame length 720 – 2420 [mm] Unit size 50-150	7–2
7.2 Base frame length 2420 – 4590 [mm] Unit size 50-150	7–3
7.3 Base frame length 4590 – 6200 [mm] Unit size 50-150	7–4
<b>Annex 8. Installation of steel roof in the sizes 10-150</b>	<b>8–1</b>
8.1 Overview	8–1
8.1.1 Mount rails. Units of size 10, 15, 20, and 25	8–1
8.1.2 Mount rails. Units of size 30 and units larger than size 30.	8–2
8.1.3 Roof overhang along the long sides of the unit	8–3
8.1.4 Calculation of the overhang at the ends of the unit. Mount overhang profile – G1.	8–3



8.1.5 Foam bands between rails and roof plates – mount roof plates.....	8—6
8.1.6 Foam bands between roof plates.....	8—6
8.1.7 Mount roof plates – some of them are overlapping by 2 ribs.....	8—6
8.1.8 Mount overhang profile – G5 on the other end of the unit.....	8—6
8.1.9 Mount side profiles and corners along the edges of the roof to protect persons.....	8—7
8.1.10 Apply sealing on plate joints to ensure water resistance.....	8—7
<b>Annex 9. Speed control for rotor and assembly of divided rotor.....</b>	<b>9—1</b>
9.1 Speed control.....	9—1
9.1.1 Selection of correct signal via the 8 DIP switch levers.....	9—1
9.1.2 Indication of operation mode via red and green LED as well as test of motor.....	9—2
9.1.3 Information about connection of cables to terminals on the control board.....	9—4
9.2 Assemble the Systemair casing for DV60, DV80, DV100, DV120 og DV150.....	9—6
9.3 Assemble divided rotor from Hoval Enventus for DV 60, DV 80 and DV 100.....	9—10
9.3.1 Tools and aids.....	9—10
9.3.2 Lifting instruction.....	9—11
9.3.3 Installation.....	9—12
9.3.4 Installation of radial walls.....	9—12
9.3.5 Measurement.....	9—13
9.3.6 Installation of rotor segment and periphery plates.....	9—14
9.3.7 Installation, first periphery plate.....	9—15
9.3.8 Installation of next segment.....	9—16
9.3.9 Installation, next periphery plate.....	9—17
9.3.10 Preparation of segments and periphery plates.....	9—18
9.3.11 Installation and adjustment of brush sealing.....	9—18
9.4 Installation of motor that turns rotor and sensor for rotation.....	9—20
<b>Annex 10. Reversible heat pump for cooling and heating.....</b>	<b>10—1</b>
10.1 DVU-HP section (reversible heat pump unit).....	10—1
<b>Annex 11. Menu for internal controller in the DVU-HP.....</b>	<b>11—1</b>
<b>Annex 12. Connection of fan motor and set-up for frekv. conv.....</b>	<b>12—1</b>
12.1 Connection of fan motor.....	12—1
12.2 Set-up for Danfoss FC101 for DV-units with AC motors.....	12—2
12.3 AC-fan operation without thermistor for Danfoss FC101.....	12—4
12.4 Set-up Danfoss FC101 for DV-units with PM motors.....	12—5
12.5 Installation ECblue.....	12—8
12.5.1 Connection.....	12—8
Residual-current-operated protective devices.....	12—9
12.5.2 Diagnostic/faults.....	12—9
<b>Annex 13. Commissioning.....</b>	<b>13—1</b>

## **a. Manufacturer**

This User Manual covers all air handling units without control system delivered by Systemair A/S.

### **Manufacturer and supplier data:**

Systemair A/S

Ved Milepælen 7

DK-8361 Hasselager

Responsible for documentation: Ulf Bang

## **b. Name of machines**

This manual is about Systemair air handling units without control systems called DANVENT DV10, DANVENT DV15, DANVENT DV20, DANVENT DV25, DANVENT DV30, DANVENT DV40, DANVENT DV50, DANVENT DV60, DANVENT DV80, DANVENT DV100, DANVENT DV120, DANVENT DV150, DANVENT DV190 and DANVENT DV240.

## c. Declaration of Conformity - example

The manufacturer:

Systemair A/S  
Ved Milepælen 7  
DK - 8361 Hasselager



Hereby declares that, air handling units of the flowing types:

DANVENT DV10, DANVENT DV15, DANVENT DV20, DANVENT DV25, DANVENT DV30, DANVENT DV40, DANVENT DV50, DANVENT DV60, DANVENT DV80, DANVENT DV100, DANVENT DV120, DANVENT DV150, DANVENT DV190 and DANVENT DV240.

TIMEec 10, TIMEec 15, TIMEec 20, TIMEec 25, TIMEec 30, TIMEec 40

Serial No: "YMMM-7XXXX-X"

are manufactured and delivered in accordance with following directives:

Machinery directive	2006/42/EC
Ecodesign – Commission regulation	1253/2014
EMC – directive	2014/30/EC
Low voltage directive	2014/35/EC
Pressure equipment directive	2014/68/EC
European Standard	EN 378-1 & 2 - 2016

Equipment type: **DVU-HP series**

Consisting of: Compressor, evaporator and condenser

Verification and Assessment by:

Notified Body Bureau VERITAS CE-0041 for PED  
Bureau VERITAS UK, "Parklands", Wilmslow Road  
Didsbury, M20 2RE Manchester

Module: A2  
Certificate no: CE-0041-PED-  
A2-SYA-001-17-DNK

The declaration is only valid, if the installation of the air handling unit is carried out according to the instructions delivered with the unit. The installer will be responsible for the CE marking and documentation, if any construction or functional changes are applied to the air handling unit.

Hasselager 14 February 2017







## d. General descriptions, dangers and warnings

TIME and DV air handling units are order specific machines available in thousands of different configurations. Only a few examples of machine configurations are described below.

The air handling units are intended for the transport and treatment of air between -40 °C and + 40 °C  
The units are exclusively for comfort ventilation.

Maintenance of the units must be carried out by skilled technicians.

On the drawing below, a right hand unit is shown because the inspection doors are mounted on the right hand side of the unit when looked in direction of SUPPLY airflow. The unit below is with rotary heat exchanger.

Position	Description	Symbol
A	Connection, supply air (to the rooms)	
B	Connection, exhaust air	
C	Connection, outdoor air in	
D	Connection, extract air (from the rooms)	



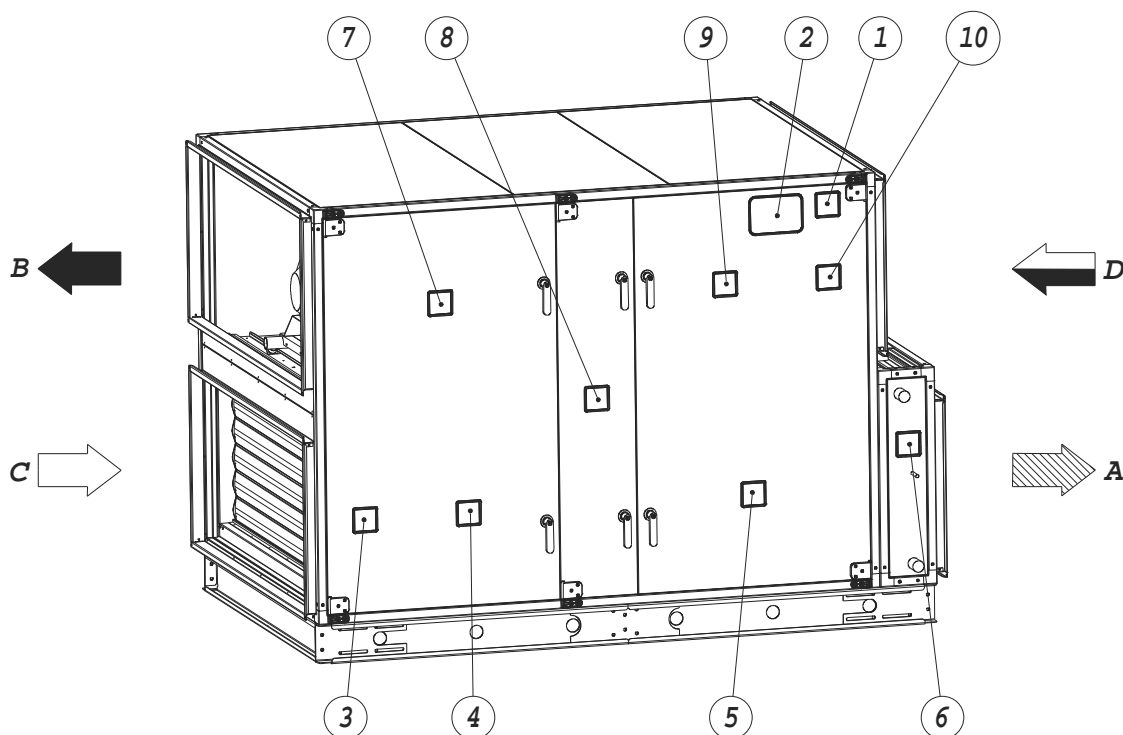





### d.1 Overview via pictograms on the inspection side of the unit



This is a right hand unit because the inspection doors are mounted on the right hand side of the unit when looking in direction of the SUPPLY airflow.

### d.1.1 Where are pictograms placed on the units

#### Example (Symbols and descriptions of functions for fast identification)

Position	Description	Symbol
1	The CE label and the unique production number of this machine	CE
2	Machine card	
3	Damper - supply air	
4	Filter - supply air	
5	Fan- supply air	
6	Heating battery - supply air	
7	Fan - extract air	
8	Rotary heat exchanger	
9	Filter – extract air	
10	Damper – extract air	

### d.1.2 Label with production number

This is the mandatory information with;  
 Product name (in this example Danvent DV 20, where 20 informs about the size of the unit), Production number for the complete unit (in this example YYMM-xxxxx-x, where YYMM informs about year and month for the manufacture), xxxxx-x is the unique production number.







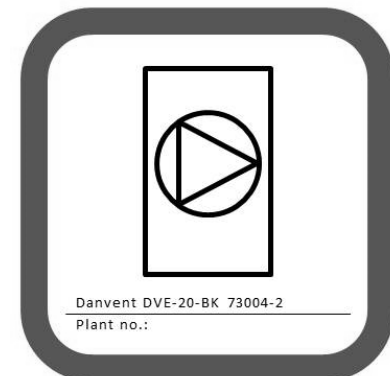







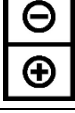

### d.1.3 Pictogram on a door for a fan in a DV unit

Example of the pictogram with the symbol for the function - fan, Systemair product name is DVE-20-BK where 20 informs about the size of the unit and BK is Backward Curved fan blades, production number for the complete unit (in this example 73004-2) and the customer's name for the unit, always written after – Plant no:\_\_\_\_\_



#### d.1.4 Pictograms for all available functions in the units

Id	Description	Symbol
DVA	Damper	
DVB	Damper	
DVM	Damper for mixing	
DVP	Damper for mixing	
DVG	Panel filter	
DVF	Bag filter	
DVC	Rotary heat exchanger	
DVQ	Plate heat exchanger (cross flow and counter flow)	
DVR	Run around heat exchanger	
DVH	Heating battery	
DVK	Cooling battery	
DVU	Heat pump unit	

DVE	Plug fan	
DVD	Silencer	
DVX	Humidifier	



**d.1.5 Pictograms about warnings and dangers on the units**

Pictograms according to EN1886 about



Warning about danger by rotating parts

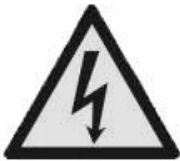

Warning about danger by electricity



Warning about danger by heat

## d.2 Data about the unit according to cards and labels in and on the unit

### d.2.1 Machine card with unique data on every unit

An example of a machine card is shown below.

Type	DV-YY			Systemair A/S
Order number	XXXXX-X			Ved Milepælen 7
				DK-8361 Hasselager
				Tel. +45 87 38 75 00
				Email: mail@systemair.dk
	<b>Supply</b>	<b>Extract</b>		
Air flow	10000 m3/h	10000 m3/h		
Total pressure drop	686 Pa	639 Pa		
Heating	31.00 kW			
Cooling	57.14 kW			
Heat recovery	82.7 %			
Heat recovery Capacity	142.8 kW			
	<b>Fan</b>	<b>Supply</b>	<b>Extract</b>	
Fan type	M-RH56Cpro	M-RH56Cpro	M-RH56Cpro	
K-factor (p=1,2 kg/m3)	308	308	308	
Fan speed	1415 RPM	1385 RPM	1385 RPM	
Maximum fan speed	1460 RPM	1460 RPM	1460 RPM	
Motor type	IE2	IE2	IE2	
Motor norm size	ABB-100LD	ABB-100LD	ABB-100LD	
Motor speed	1445 RPM	1445 RPM	1445 RPM	
Power	3.0 kW	3.0 kW	3.0 kW	
Voltage	3x400 V	3x400 V	3x400 V	
	<b>Filter</b>	<b>Supply</b>	<b>Extract</b>	<b>Sales agent:</b>
Filter class	F7	F7	F7	Systemair Fans & Spares Ltd
Dimensioning pressure drop	130 Pa	130 Pa	130 Pa	72 Cheston Road, Birmingham, B7 5EJ
Initial pressure drop	71 Pa	71 Pa	71 Pa	England
Final pressure drop	189 Pa	189 Pa	189 Pa	Tel: + 44 (0) 121 322 0200
				<a href="http://www.systemair.co.uk">http://www.systemair.co.uk</a>

### d. 3 Dimensions of the units

See annex 2 with information about the exact dimensions.

### d.4 About operation and control.

The air handling units must be completed for fully automatic operation. Control must be limited to change of parameters via buttons and display on a hand terminal. The alternative is that the controller is connected to a BMS system with the ability to select new parameters via PC, tablet or Smartphone.

### d. 5 Warnings about dangers

Pictograms are according to EN1886 about;



Warning about danger by rotating parts



Warning about danger by electricity



Warning about danger by heat



Disregards of instructions shown on warning signs are connected by risk for injury or damage on material.

## e. Drawings, diagrams, guides and instructions for the use, maintenance and repair

All DV units with integrated control system and TIME units are manufactured in compliance with the EC Declaration of Conformity and they are CE marked as machines. Unique Declaration with production number of the machine is an integral part of the machine – enclosed as annex 1 to this manual. If the buyer carries out changes or adds components in or on the machine, the buyer must issue a new EC Declaration of Conformity and a new CE marking of the machine. To promote correct use of the machines, the below-mentioned instructions are an integral part of the machine:

- Unique drawings, data and description of functions for the delivered unit – annex 2

- Instructions for use of the machine – section k in this manual
- Instructions about adjustment and maintenance – section r in this manual
- Safety during adjustment and maintenance – section s

## **f. Employees in charge of operation/control/maintenance**

After start-up and hand-over from installer to operators, the unit operates fully automatically. Indications of operating status as well as indication of faults are visible in a display and on LEDs at a hand terminal. The operators can enter new parameters in a controller via buttons on a hand terminal. Alternatively, the controller can be connected to a BMS system so that new parameters can be selected via PC, tablet or Smartphone. The operators do not need to open inspection doors for the operation

Skilled technicians must carry out maintenance as well as repairs.

## **g. Intended use and range of applications**

The air handling units are intended for the transport and treatment of air between -40 °C and + 40 °C. The units are exclusively for comfort ventilation. The units are not for environments that exceed the corrosion class C4 according to EN ISO 12944-2.

Intended applications for the units are:

Offices, teaching rooms, hotels, shops, homes and similar comfort zones.

## **h. Unintended use and misuse – inappropriate applications for the machine**

Units for outdoor installation must be specified and ordered for outdoor installation.

The units must not be used in environments that exceed corrosion class C4 according to EN ISO 12944-2, and for transport of solid particles.

Examples of not intended use:

Kitchen extraction, swimming pools, off-shore, Ex-areas, drying of washed clothes.

Do not use the unit with partly finished duct systems. Do not use the unit for ventilation of the building site until the unit is properly provided with guards.

### **h.1 Air handling unit in operation**

The pressure difference between interior and exterior of the unit must not exceed 2000 Pa for the DV 10 and up to DV 150 (including DV 150), and 1500 Pa for DV 190 and DV 240.

Before start-up of the unit all ducts, safety guards and all protective devices must be mounted to prevent any access to rotating fan impellers. All inspection doors must be closed and locked when the unit is in operation.

Do not use the unit without filters.

## **i. Instructions for unloading on the site as well as installation and connection**

### **i.1. Unloading on the site**

The air handling unit – AHU - is delivered as one section or in several sections, which are to be assembled on site. The AHU is delivered on transport pallets, legs or on a base frame. Loading and unloading as well as transport on the site is possible by fork-lift truck or by crane using suitable lifting straps.

#### **i.1.1 Unloading by fork-lift truck.**

The forks of the truck must be sufficiently long to avoid any damage to the AHU underside.

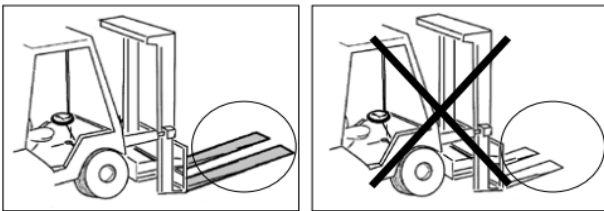

#### **i.1.2 Unloading by crane**

AHU delivered on transport pallet must be lifted by straps as shown in the illustration.

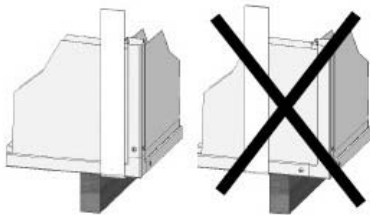

AHU delivered with legs must be lifted by straps secured to the legs as shown in the illustration.

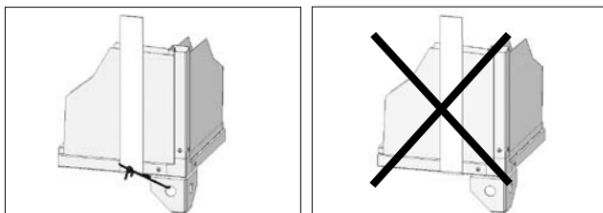

#### **i.1.3 Transport of unit without base frame on the site**

Units without base frame are always delivered in sections with each section on a pallet. Sections can be transported on the site by hand manual forklifts.

#### **i.1.4 Lifting a unit with straps**

Use an appropriate lifting beam with a sufficient span to avoid that the straps touch and damage the drip nose profiles and the inspection side with handles, pipes and accessories – for example manometers, cabinets, tabs for measuring the pressure.

**i.1.5 Lifting a unit with preinstalled brackets on the base frame for lifting.**

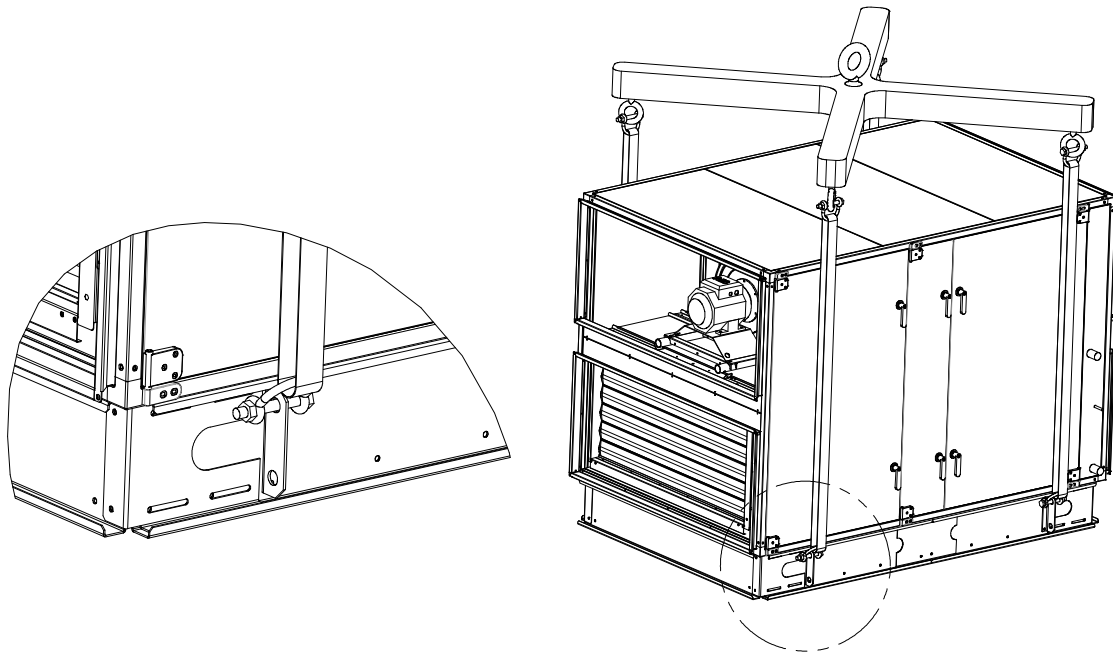

Lifting beam and straps are not included in the delivery.

**i.1.6 Roof unit with bitumen roof**

Avoid damaging the drip nose profiles along the bitumen roof. Keep the protection profiles of Styrofoam on the unit until the installation has been completed. If the unit is lifted by straps, the straps must be kept away from the drip nose profiles by bars to avoid damage to roofing profiles.

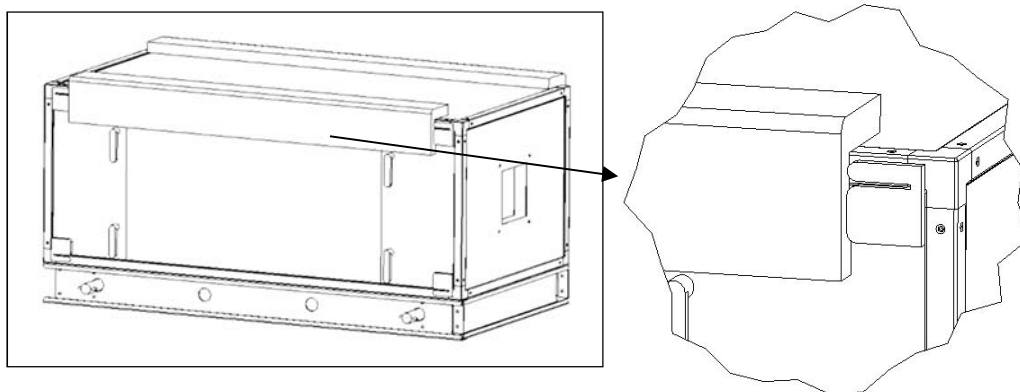

### i.1.7 Roof unit with steel roof

For units with steel plate roof, the steel plates are delivered uninstalled on a separate pallet. Do **not** step or walk on the plates.



### i.1.8 Pre-assembly storage

The AHU must be protected from the weather and accidental impact. Plastic packaging **must** be removed and the unit covered with tarpaulin or similar materials. In order to minimize condensation, sufficient air circulation must be ensured between the covering and the unit.

### i.1.9 Tilt less than 30° during transportation of the section with heat pump – DVU

During transportation, the unit section - DVU **must** always be in the upright position or tilted less than 30°. If it is necessary to tilt the unit more than 30°, the suction pipe of the compressor must point upwards to prevent the escape of oil from the compressor sump.

## i.2. Installation - mechanical

### i.2.1 Free area in front of and above the unit

**Important!** When positioning the unit on the site, it must be ensured that an area with the same width as the unit is kept free for service and inspection and also for replacement of fans and exchanger, if needed. The width of the free area must be at least 900 mm.

**Important!** For safe access to the cabinet with electrical components, if the cabinet is placed on top of the unit, the free area from the upper edge of the cabinet to the ceiling must be at least 700 mm.

### i.2.2 Supporting surface

The surface beneath the unit must be level, horizontal and vibration-free. The surface must be able to withstand the load of the AHU. Weights of the sections are written in Annex 2.

**Remember!** Duct work must be sound insulated and must not be mounted directly on beams, trusses or other critical building parts.

### i.2.3 Adjustable feet under legs or base frame and transport of sections

Adjustable feet are provided in a carton box placed inside the unit. Adjustable feet are delivered for indoor units and not for outdoor units.

Sections can be transported on the site by hand manual forklifts or similar. The frame profiles in the edges of the sections have carrying capacity for lifting by the hand manual forklifts.

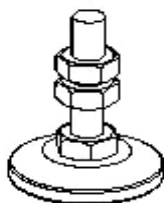

### i.2.4 Base frame assembly

Base frame is delivered unassembled for the indoor units that are delivered in sections on pallets. Assembly of the base frame is illustrated on 4 pages in a manual in a plastic bag which is attached to one of the large base frame parts.

The 4 pages with the illustration regarding the assembly of the base frame are also available in this user manual in annex 4, 5, 6 or 7.

There are two types of base frames:

1. 150 mm high base frames
2. 250 mm high base frames

There are 4 different manuals and each of them illustrates the assembly of the 4 different types of base frames:

1. Manual about the 150 mm high base frames for AHUs in the sizes from DV 10 to DV 40. The name of this manual is – **Base frame 150 DVZ 10 - 40**
2. Manual about the 150 mm high base frames for AHUs in the sizes from DV 50 to DV 150. The name of the manual is – **Base frame 150 DVZ 50 - 150**
3. Manual about the 250 mm high base frames for AHUs in the sizes from DV 10 to DV 40. The name of the manual is – **Base frame 250 DVZ 10 - 40**
4. Manual about the 250 mm high base frames for AHUs in the sizes from DV 50 to DV 150. The name of the manual is – **Base frame 250 DVZ 50 – 150**

#### Example of 250 mm high base frame for AHUs in the size from DV 10 - 40

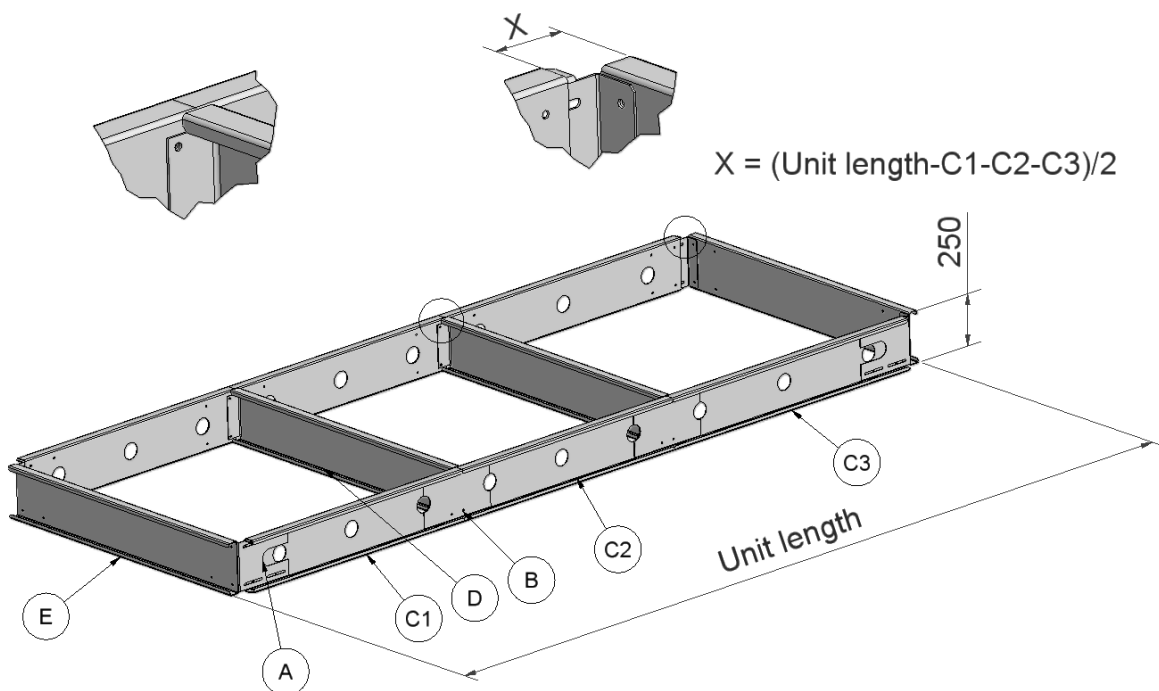

Mount adjustable feet with a distance of maximum 1500 mm between each foot under the base frame. The base frame can now be levelled by the adjustable feet. The next step is to place and assemble AHU sections on the base frame.



### i.2.5 Base frames for outdoor units

Outdoor units must be installed on 250 mm high base frames and are always fitted to the AHU sections. Hot-dip galvanized base frames are recommended for outdoor units. Systemair delivers these base frames without the above mentioned adjustable feet.

### i.2.6 Installation on the site of unit sections at the base frame when sections are delivered on pallets

Lift up the section by hand manual forklifts to the level where the underside of the section is even with the overside of the base frame.

1. Pull the section to the correct position on the base frame by lifting straps – it is maybe necessary to support the section by heavy duty furniture trolleys (see the photos below)



Example of heavy duty furniture trolley turned with the wheels upwards. Placed in this way on the forks of the hand manual forklifts the heavy duty furniture trolleys are suitable for safe and careful rolling of the unit sections over to the base frames.



Example of very heavy duty furniture trolleys. Turned with the wheels upwards and placed on the forks of hand manual forklifts these heavy duty furniture trolleys are very suitable for safe and careful rolling of the unit sections over to the base frames.

2. Pull sections together with lifting straps. We recommend the below shown type of brackets because this type is not damaging the frame profiles of the units. An example of lifting strap is shown below.

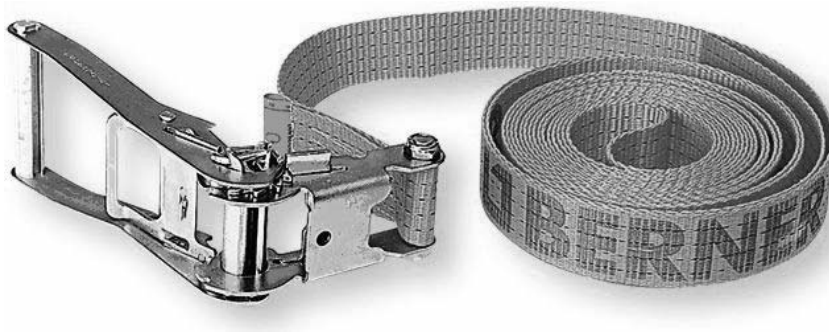
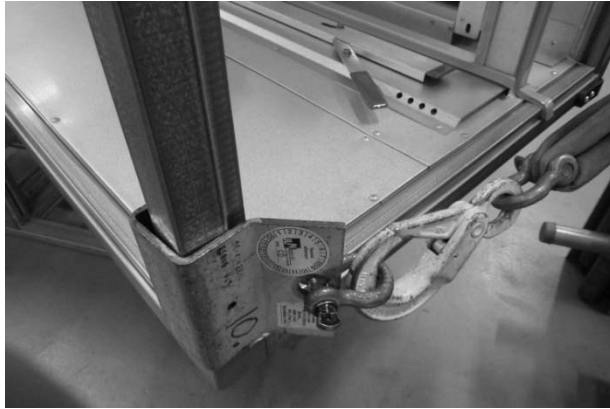

3. Sections are mounted to base frames with long self-drilling screws. The frame profile under the inspection doors is placed over the horizontal profile of the base frame. See the example on the photo below.



### i.2.7 Joining the AHU sections

The sections must be placed on the base frame and if the unit is delivered with 100 mm legs, the sections must be positioned directly opposite each other.

1. Ensure that the internal factory-fitted rubber sealing is undamaged
2. The sections are then to be positioned directly opposite each other. If the sections are built with legs, the adjustable feet can be used to get the sections parallel and at the same height.
3. Press the sections hard together so that the rubber profiles are so flat that the iron frames of the two sections are joined. Straps with tensioner as shown below are suitable for pressing the sections hard together.

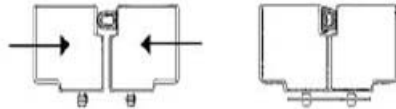

4. The sections are then to be locked permanently together with the black plastic-coated Systemair Disc-Locks. The Disc-Locks are delivered in a carton box placed inside the unit. Place each Disc-Lock over the 2 factory fitted locking pins. The discs and locking pins are not reliable for pulling the sections together. They are only sufficient for keeping the sections well together, so just turn each disc gently with the supplied Allen key. Use a sequence where each disc is tightened with only one click at a time. If the unit is placed too close to a wall with no space left for the mounting of Systemair Disc-Locks, brackets must be placed inside the unit to keep the sections permanently together (brackets for this purpose are not delivered by Systemair)

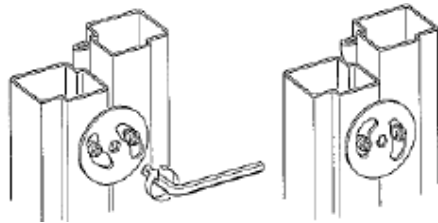

### i.2.8 Fitting the ductwork

Flexible duct connections between AHU and ductwork must always be installed. Be sure that flexible duct connections are almost fully stretched. (Flexible connections are ordered as accessories and they are placed inside the unit). At the fan outlet on a centrifugal fan, the duct size should be as close to the outlet size as possible. Avoid blockage and turbulence at the fan outlet.

### i.2.9 Risk of stack effect by vertical ducts and wind pressure on louvers

On special occasions stack effect – also called chimney effect – in the ducts create airflows that drives the impellers by turned off motors.

A rotating impeller is a potential hazard during cleaning and maintenance of the unit.

Eliminate this airflow by dampers with spring return motors for automatic closing of the dampers - even by power failure.

**Important!** The Systemair air handling units can be ordered and delivered without dampers, and the installer/user must check that duct systems with the described risk of stack effect (chimney effect) will be provided with dampers and spring return motors.

## i.2.10 Remove transport brackets – when spring mounts are installed

### i.2.10.1 Impeller diameters 220 – 560 mm

If the fans are installed on spring mounts the transport brackets must be removed after the installation of the air handling unit. Two transport brackets are fitted to the coil springs during transport and installation. Both transport brackets must all be removed to give the full anti-vibration function to the coil springs. The transport brackets are made more visible with yellow labels. After removal of the transport brackets they must be disposed of safely.

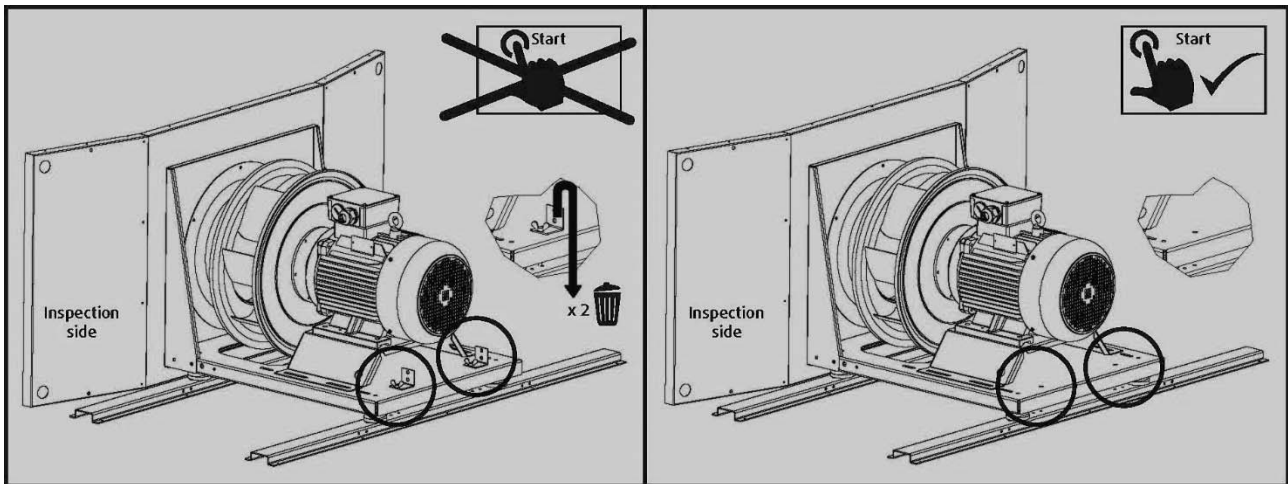

After disposal of the transport brackets the yellow label on the outside of the fan inspection door has no function and should be removed.

### i.2.10.2 Impeller diameters 630 – 1.000 mm

If the fans are installed on spring mounts the transport brackets must be removed after the installation of the air handling unit. Four transport brackets are fitted to the coil springs during transport and installation. The four transport brackets must all be removed to give the full anti-vibration function to the coil springs. The transport brackets are made more visible with yellow labels, as shown in the picture below. After removal of the transport brackets they must be disposed of safely.

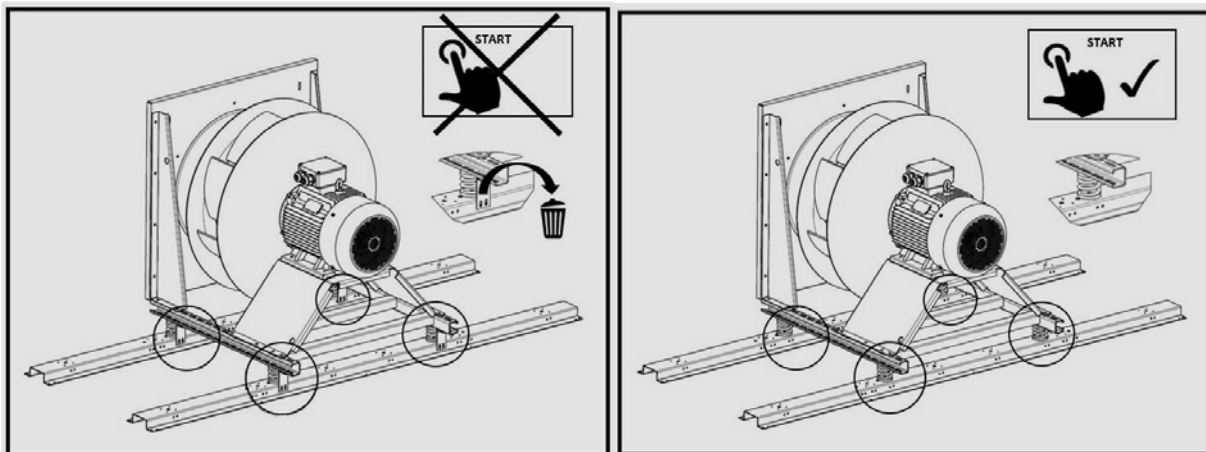

After disposal of the transport brackets the yellow label on the outside of the fan inspection door has no function and should be removed.

### **i.2.11 Refitting of guards**

The guard is a safety guard installed inside the door. Tools are necessary for the removal of the guard. If the guard has been demounted during the installation on the site, the guard must be refitted before startup of the unit.



Insert the edges of the guard in the frame profile in the groove that is in the frame profile, and connect both parts of the guard at the middle with 2 screws.

Replace the vibration damping foam rubber list if it is damaged.

### **i.3. Installation - electrical**

#### **i.3.1 Necessary overvoltage protection device, that leads lightning overvoltage to an earth lead on a safe way.**

The Installer and user must be aware of the fact that lightning strikes make a risk that requires installation of overvoltage protection devices to lead the lightning overvoltage to an earth lead in a safe way. Installer and user must take care of this according to local statutory requirements.

### **i.4 Installation – Pipes for water – hot and chilled, valves and drains**

#### **i.4.1 Description**

If ordered with the unit, the valves and valve motors are stored in a carton box placed inside the unit. Water trap(s) – standard or optional - is (are) necessary to ensure escape of water from the tray under plate heat exchanger and (or) cooling coil. Water trap(s) is (are) stored in a carton box placed inside the unit.

## **i.4.2 Pipe connections**

Connection pipes on heating- and cooling coils are provided with external thread. Drainage outlets on drip trays are provided with external thread.

## **i.4.3 Possibility of extracting components from the unit**

Pipes and cables must not obstruct the inspection doors and components which can be extracted from the unit. Potential components for extraction are filters, fans and rotary heat exchanger.

## **i.4.4 Pipe connections to batteries**

### **i.4.4.1 Heating coils**

Pipes for hot water must be protected by insulation against frost and loss of heat. Further protection against frost can be obtained by installing electrical heating wires around the pipes and under the insulation combined with temperature sensors and a control system. Pipes, insulation, electrical heating wires, control system for heating wires and circulation pump are not delivered by Systemair.

### **i.4.4.2 Cooling coils**

If ordered with the unit, the valves and valve motors are stored in a carton box placed inside the unit. Pipes for cooling must be protected by insulation against condensation on the pipes and loss of cooling in the summer. Pipes and insulation are not delivered by Systemair.

### **i.4.4.3 Rigid pipe mounting brackets for valves, circulation pumps and pipe system**

The coil and pipes from the coil are not constructed to withstand the weight and stress from valves, circulation pumps, long pipes and insulation of pipes. The system must be supported carefully in rigid pipe mounting brackets to roof, floor and walls.

#### **i.4.4.3.1 Pipe connection to heating coils**

The heating capacity of the coil with only 2 rows is independent of the connection of the hot water in equal flow or in counter flow to the direction of the air, but connection of the hot water to the pipe marked for inlet and the return water to the pipe marked for outlet is very important to ensure that the sensor for transmission of the water temperature really will be placed in a return circuit of the coil (Screw-joint for the water temperature sensor is welded in the main collection pipe for return water).

**For the frost protection of heating coil**, the water temperature in the coil is transmitted to the controller

The controller always generates a signal to the valve motor that keeps a sufficient flow of hot water to protect the coil against frost. This frost protection is also activated when the running mode is "off".

Coils with 3 rows or more must always be connected in counter flow to the airflow.

**NOTE:** If glycol is added, the glycol must be without additives and auto glycol must not be used. Automatic bleeding has to be installed at the highest point of the 2 pipes — supply or return pipe.

If the heating battery is built with 3 or more rows, the water flow must be in counter flow to the direction of the air.

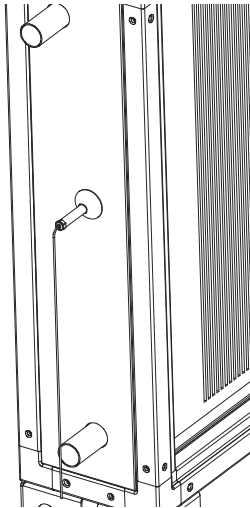

To protect against frost a temperature sensor for the transmission of an analog signal to the controller is placed in a pipe on the collection pipe for return water. The sensor must be fitted water tight with a cap in the pipe before water under pressure is in the battery. The pipe for the sensor is soldered on the collection pipe and it is important to hold contra on the pipe, when the cap is tightened.

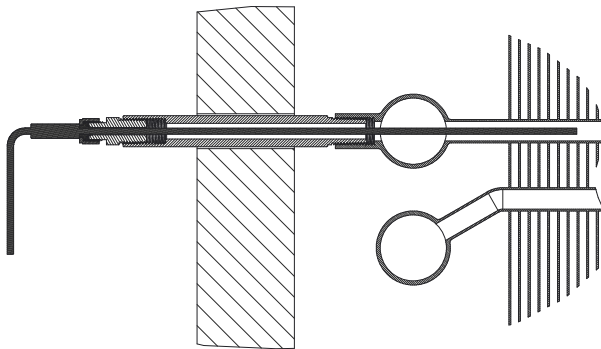

**Battery seen from above.** The sensor measures the water temperature of the water inside one of the small pipes for return water in the battery. The sensor reduces the area in this pipe and hereby also the flow of warm water in this pipe. The temperature in this pipe is reduced more than the temperature in all other pipes by the airflow through the battery. Because the lowest temperature in the battery probably is measured here, this system creates early and safe warning of frost.

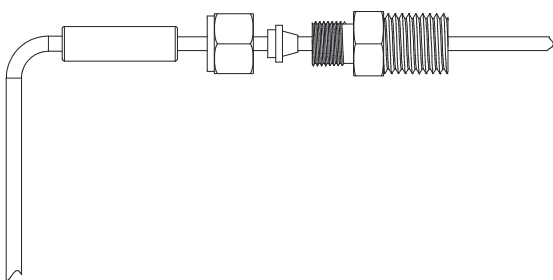

It is important that the cap is tightened sufficient to keep the sensor system fully water tight.

#### i.4.4.3.2 Pipe connection to cooling coils for chilled water

Coils with 3 rows or more must always be connected in counter flow to the airflow.

**NOTE:** The glycol must be without additives and auto glycol must not be used.

Automatic bleeding has to be installed at the highest point of the 2 pipes — supply or return pipe.



### i.4.5 Draining condensate water

Drip trays for collection of condensate water are installed under plate heat exchanger and cooling coil. Each drip tray is provided with a drainage outlet. A water trap is always necessary. To avoid freeze ups and frost bursts of water trap and pipes, sufficient insulation is recommended and installation of heating between the insulation and water trap/pipes could even be necessary (insulation, heating and controller for the heating are not delivered by Systemair).

### i.4.6 Draining condensate water from plate heat exchanger

Condensate from the plate heat exchanger is collected in the drip tray. Heavy negative air pressure in this section prevents the water from flowing out of the drainpipe. A water trap with sufficient closing level of the water is essential to ensure that condensate water flows out of the unit. The closing level of the water trap must be estimated correctly to ensure safe escape of the water (see the illustration and estimate the minimum closing level according to the table). The pipe diameter of the water trap and sewage system must be identical to the pipe diameter of the drainage outlet from the tray.

A water trap is optional and installation of the water trap is not included.

**Remember to check that there is water in the water trap.**

#### Negative pressure P (Pa)

P	H1 Minimum	H2
500 Pa	100 mm	40 mm
750 Pa	150 mm	55 mm
1.000 Pa	190 mm	70 mm

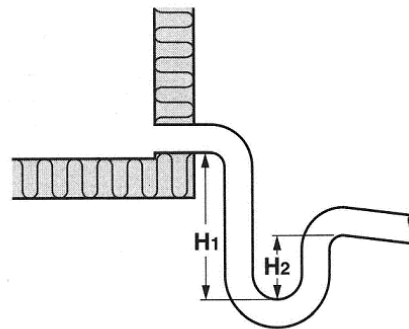

### i.4.7 Draining condensate water from cooling battery

If the cooling battery and the drip tray is placed in the unit where negative pressure (underpressure) occurs, the closing level of the water trap must be estimated correctly. See the above-mentioned information in section i.4.6 – Draining condensate water from the plate heat exchanger.

If the cooling battery and the drip tray is placed in the unit where positive pressure (overpressure) occurs, the closing level of the water trap must be estimated correctly as shown on the illustration below. A water trap is optional and installation of the water trap is not included.

**Remember to check that there is water in the water trap.**

#### Positive pressure P (Pa)

P	H1 Minimum	H2
500 Pa	90 mm	65 mm
750 Pa	120 mm	90 mm
1.000 Pa	150 mm	120 mm

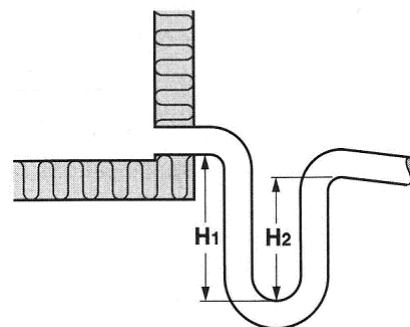

## **j. Installation and assembly instructions for reduction of noise and vibration emissions**

Due to the design and construction of the units the (A) weighed sound pressure level from fans and other components do not exceed 70 dB (A) outside the units.

Data about sound in annex 2.

Installation of the units on springs will reduce the transmission of noise and vibrations to the building.

Systemair does not deliver springs for this purpose.

Flexible connections between the units and the ducts are available as accessories.

## **k. Instructions for putting into service, adjustments, use and commissioning.**

### **k.1 Print-outs on paper**

The documents listed below are always printed on paper and delivered together with the units according to the Machinery Directive and the related national laws

This User Manual with;

- Declaration of incorporation – annex 1
- The unique technical data for this unit - annex 2
- Installation instructions including instructions for the Danfoss frequency converter – annex 4-12
- Printed form for Commissioning protocol - annex 13

### **k.2 Electronic media**

A DVD is delivered with every unit. The below-mentioned documents are available on every DVD and this means that every DVD is provided with information about many components that are not delivered with every unit. The documents on the DVD:

Common

- This User Manual
- Operator's Guide
- Commissioning Protocol as a Word-file for modification by the installer

Components in the control system

- Danfoss frequency converter
- Damper motors
- Filter guards
- Pressure transmitters

### **k.3 Documentation is available for download from <https://techdoc.systemair.dk>**

Your local Systemair company is able to provide the data.

### **k.4 Start-up by installer**

All protection and safety measures must be met before start-up of the unit. The mains supply voltage must also be checked too.

#### **k.4.1 Checklist, relevant values**

#### **k.4.1.1 Checklist prior to start-up**

- Is the unit assembled correctly with its functions in the correct order? See annex 2.
- Are the sections and ducts assembled correct? See annex i.
- Check that fans and anti-vibration mounts are not damaged after transportation and installation.
- Is the rotary exchanger turning freely?
- Are safety guards installed correctly?
- If the unit includes integrated heat pump(DVU), check whether it is installed and supervised by qualified service personnel.
- If the unit contains Electric air heater, make sure that the supply isolator disconnects with the unit.
- Ducts - are all ducts installed?
- External components - are the valve and valve motor installed correctly?
- Is the circulation pump installed correctly?
- Is water under pressure in the coil and circulation pump?
- Are the pressure transmitters installed and connected correctly? (If this is a system with pressure transmitters in the ducts)
- Main power supply:
  - Connected correctly? (3x400 V + N + PE)
  - Are control signals for actuators connected correctly?

#### **k.4.1.2 Switch on power**

Do not start until all safety procedures have been completed and ensure that inspection doors are closed and locked.

Switch on power and the unit should be ready for the start-up.

### **k.5 Description of functions**

#### **k.5.1 Heating coil for hot water prepared for temperature sensor (frost protection)**

From Systemair every heating coil for hot water is provided with a little pipe at the collection pipe for the return water. This little pipe is prepared for the installation of a temperature sensor for the transmission of the return water temperature to the controller. The temperature sensor is not included.

#### **k.5.2 DX cooling**

Cables and flow guard are not delivered by Systemair

#### **k.5.3 Circulation pump, heating**

Circulation pump is not included in the delivery from Systemair.

#### **k.5.4 Electrical heater battery**

##### **k.5.4.1 Control of heating capacity connected to unit without Systemair control system**

Electrical heater installed with separate controller beside the heater. The separate controller is designed for capacity conversion of 0-10 V control signal from the main control system. No power supply cables are connected to the electric heater. The separate controller for the heater is without supply disconnecting device.

### k.5.5 Speed control of fans

#### k.5.5.1 Frequency converters inside the unit are IP 20

Fan motor revolutions are controlled by frequency converters. **Shielded cable must be used between the frequency converters and the motors.**

#### k.5.5.2 Frequency converters on the unit are IP 54

Fan motor revolutions are controlled by frequency converters. **Shielded cable must be used between the frequency converters and the motors.**

### k.5.6 Pressure transmitters

Separate control of the air flow or duct pressure for supply fan and for extract fan. The required air flow or duct pressures with normal as well as reduced capacity are selected on the Control Panel. The actual pressure is measured by pressure transmitters. PI calculation in the controller continuously transmits the necessary revolutions for the fans to the frequency converters to achieve the required pressure.

### k.5.7 Damper motors

Four different types of damper motors are available;

- On/off damper motor, without spring return function. Torque is 20 Nm and run time is 150 seconds
- Modulating damper motor, without spring return function. Torque is 20 Nm and run time is 150 seconds
- On/off damper motor, with spring return function. Torque is 20 Nm and run time is 150/16 seconds
- Modulating damper motor, with spring return function. Torque is 20 Nm and run time is 150/16 seconds

### k.5.8 Filter guards

Filter guard over pre-filter and primary filter installed and connected to the controller for display of alarm when the mechanically set limit is exceeded. Filter alarm will be displayed on the Control Panel.

## k.6 Commissioning

When the installer has completed the installation and wants to hand over the finished installation to his customer for payment the commissioning protocol can be the written receipt for the full ended job. Fill in the blank spaces and sign the proposed commissioning protocol that is annex 13, or fill in the Word-file with a Commissioning Protocol that is included on the DVD delivered with the unit.

## **I. Information about the residual risks that remain despite the inherent safe design measures, safeguarding and complementary protective measures adopted.**

### I.1 Unit casing.

#### I.1.1. Design of the machine to make transport safe

##### Hazards/dangerous area:

Incorrect handling during transportation may cause that the unit is dropped.

##### Dangerous incident:

If a person is hit by a unit that is dropped, this could in unfortunate circumstances lead to irreversible injury or death.

Claim for reduction of danger:

Correct handling during transportation is described in this manual. If lifted by fork-lift truck the forks of the truck must be sufficiently long. Safety measures are also described in this manual by use of crane. Information about weight of each section is also visible.

## **I.2 Common for all unit sections**

### **I.2.1 Risk caused by surfaces, edges and corners**

Hazards/dangerous area:

Sharp edges on plates might occur inside the machines as well as sharp edges on frames of dampers. No sharp edges on the outside of the units.

Dangerous incident:

Cut fingers/hands.

Claim for reduction of danger:

Risk only exists during maintenance and cleaning. This takes place at least once every year. Use of gloves and helmet is described in this manual. Cut-resistant gloves for protection against injury from sharp metal plate edges. Use CE-marked gloves for this purpose. Lamps mounted inside the unit with sufficient lighting reduce the risk of injury.

## **I.3 Common for all unit sections by insufficient lighting**

### **I.3.1 Risk caused by insufficient lighting inside sections**

Hazards/dangerous area:

On the floors of the units there are handles to hold filters, profiles for the carrying of fan motors. Cables are between fan motors and frequency converters.

Dangerous incident:

By insufficient lighting, the above-mentioned obstacles are not visible with the risk of stumbling that becomes a fall, leading in unfortunate circumstances to irreversible injury or death.

Claim for reduction of danger:

Risk only exists during maintenance and cleaning. This takes place at least once every year. According to this manual and in the SystemairCAD software for configuration and selection of accessories, lamps for sufficient lighting inside the units are mandatory according to the latest interpretations of the Machinery Directive by the authorities. Use of helmets reduces the risk of injury.

## **I.4 Dampers type DVA – DVB – DVM – DVP – Bypass dampers in DVQ**

### **I.4.1 Risk caused by maintenance and cleaning of dampers**

Hazards/dangerous area:

Are between the damper blades and the system of bars and links between motor and damper blades.

Dangerous incident:

Crushing of fingers.

Claim for reduction of danger:

Examination is still under preparation in our own laboratory. Still no voluntary test persons are available.

## **I.5 Attenuators type DVD**

### **I.5.1 Risk caused by maintenance and cleaning of attenuators**

Hazards/dangerous area:

High concentration of dust on the surface of the baffles might be harmful to the health.

Dangerous incident:

To breathe in particles that is harmful to the health.

Claim for reduction of danger:

Risk only exists during maintenance and cleaning. This takes place at least one time every year. Use of particulate respirator is described in this manual. Particulate respirator – maintenance free including foam face-seal and adjustable pre-threaded headbands (same particulate respirator as recommended for change of filters).

### **I.6 Filters type DVG – DVF**

#### **I.6.1 Risk caused by missing change of filters**

Hazards/dangerous area:

Missing change of filters and missing maintenance decrease the capacity and final consequence will be breakdown.

Dangerous incident:

By extensive lack of of filter change and maintenance the machine can break down.

Claim for reduction of danger:

In the manual is the method and schedule for change of filters and maintenance specified.

#### **I.6.2 Risk caused by the execution of filter change**

Hazards/dangerous area:

Filter panels and filter bags

Dangerous incident:

To breathe in particles that is harmful to the health.

Claim for reduction of danger:

Use of particulate respirator – maintenance free including foam face-seal and adjustable pre-threaded headbands (same particulate respirator as recommended for cleaning of attenuators).

### **I.7 Plug fans type DVE**

#### **I.7.1 Risk caused by lightning strike**

Hazards/dangerous area:

Lightning strike close to the machine.

Dangerous incident:

Lightning strike can create flash over between phases and conductive parts. This can cause fire or the overvoltage can make injury on persons

Claim for reduction of danger:

Installer and user must be aware of the fact that lightning makes a risk that requires installation of overvoltage protection devices to lead the lightning overvoltage to an earth lead on a safe way. The need for overvoltage protection devices depend on where the unit is placed in and on the building.

Installer and user must take care of this according to local statutory requirements. Overvoltage protection devices are also described in section i.3.1 of this manual.

### **I.7.2. Risk caused by permanent magnet motor**

Hazards/dangerous area:

Rotation of the shaft generates electricity. This danger is always visualized by a yellow warning label on the inspection door where permanent magnet motors are installed.



Dangerous incident:

Persons touching conductive parts get electric shock, burns, heart flicker and so on.

Claim for reduction of danger:

By installation or repairs of conductive components, the shaft must be blocked to prevent any rotation.

### **I.7.3 Risk of rotating impeller caused by stack effect (chimney effect).**

Hazards/dangerous area:

On special occasions stack effect – also called chimney effect – in the ducts create airflows that drives the impellers by turned off motors.

Dangerous incident:

Injury of fingers, hands and arms.

Claim for reduction of danger:

Eliminate this airflow for supply air and exhaust air by dampers with spring return motors for automatic closing of the dampers by turned off fan motors and by power failure.

## **I.8 Batteries for heating and cooling type DVR – DVH – DVK – DVU**

### **I.8.1 Extreme temperatures - heating**

Hazards/dangerous area:

Electrical heating elements can achieve surface temperature of 500 degree Celsius.

Batteries and pipes for hot water can achieve 95 degree Celsius.

Dangerous incident:

According to ISO 13732-1:2006, here is no direct risk of burns. (short-time contact – lesser than 2,5 sec).

Claim for reduction of danger:

No.

### **I.8.2 Extreme temperatures - cooling**

Hazards/dangerous area:

Evaporator batteries and pipes connected to cooling compressor can achieve minus 10 degrees Celsius.

Dangerous incident:

According to ISO 13732-1:2006, here is no direct risk of burns. (short-time contact – lesser than 2,5 sec).

Claim for reduction of danger:

No.

## I.9 Heat pump units type DVU

### I.9.1 Risk of high temperature

Hazards/dangerous area:

Condenser batteries and pipes can achieve temperature of 60 degree Celsius.

Dangerous incident:

Vurderet ud fra ISO 13732-1:2006, der er umiddelbart ikke risiko for forbrændinger. (berøringstid 2,5 sek).

Claim for reduction of danger:

No.

### I.9.2 Risk caused by lightning strike

Hazards/dangerous area:

Lightning strike close to the machine.

Dangerous incident:

Lightning strike can create flash over between phases and conductive parts. This can cause fire or the overvoltage can make injury on persons.

Claim for reduction of danger:

Installer and user must be aware of the fact that lightning makes a risk that requires installation of overvoltage protection devices to lead the lightning overvoltage to an earth lead on a safe way. The need for overvoltage protection devices depend on where the unit is placed in and on the building.

Installer and user must take care of this according to local statutory requirements. Overvoltage protection devices are also described in section i.3.1 of this manual.

## m. Instructions on the protective measures to be taken by all service technicians during repair and maintenance

Use the below-mentioned personal protective equipment for maintenance:

- Cut-resistant gloves for protection against injury from sharp metal plate edges. Use CE-marked gloves for this purpose.
- Helmet
- Particulate respirator – maintenance free including foam face-seal and adjustable pre-threaded headbands – for replacing filters.
- Padlock for locking the automatic circuit breakers in off position
- Permanent magnet motor. The shaft must be blocked during repairs and maintenance of the electric system (the motor generates electricity by rotation – for example that the wind and thermic drives the fan/motor).
- Lighting inside the units. According to the latest interpretations of the Machinery Directive by the authorities sufficient lighting inside the units is mandatory.
- Tools to block the impeller during repairs and maintenance if stack effect – also called chimney effect – in the ducts create airflows that drives the impellers by turned off motors

## n. The essential characteristics of tools which may be fitted to the machinery

The subject in the Machinery Directive about tools on the machine does not exist for the DV air handling units, because those tools does not exist.



## **o. The conditions of stability during use, transportation, assembly, dismantling when out of service**

The unit must always be handled in an upright position. Never tilt any section more than 15 degrees. If sections must be tilted more than 15 degrees, sections with fans or rotating exchangers that can be drawn out for service must be secured carefully.

During transportation, installation, dismantling or other handling, it must be secured that all components in the unit are properly fastened and with additional attention to the control of anti-vibration mounts under the fans that they are undamaged. The mounting and smooth running of the fans must be controlled and handled with great care.

### **o.1 Installed reliable to avoid units to be tilted or moved by the any storm.**

Units installed on roofs and other places with the risk of heavy winds must be installed reliable to avoid that they can be tilted or moved by the any storm. The base frame is provided with holes that are intended for fastening by sufficient bolts and fittings supplied by the installer.

### **o.2 Transport of section with heat pump unit**

During transportation, the unit section – DVU - **must** always be in the upright position or tilted less than 30°. If it is necessary to tilt the unit more than 30°, the suction pipe of the compressor must point upwards to prevent the escape of oil from the compressor sump.

### **o.3 Disposal of the heat pump system - type DVU**

Prior to the disposal of the DVU unit section, the refrigerant in the heat pump system must be drained off by a skilled technician from a certified company. After correct evacuation of the refrigerant, the disposal of the DVU unit section is similar to the disposal of the rest of the air handling unit.

### **o.4 General disassembly – sharp edges**

Pay attention to several sharp edges during dismantling and disposal of the unit. To avoid injury, CE-marked cut-resistant gloves as well as helmet must be used. The measures are described further in the Maintenance, Dismantling and Disposal Manual.

## **p. Instructions for machinery where these are regularly to be transported**

The subject in the Machinery Directive about machinery that are regularly to be transported does not exist for the DV air handling units, because those units are for specially made for one intended application.

## **q. The operating method to be followed in the event of breakdown. Safe restart.**

Use the below mentioned procedure in the event of breakdown or blockage:

- Switch off the power and lock the automatic circuit breaker by padlocks in the off position.
- Remove the reason for breakdown or blockage.
- Follow the start-up procedure described in section k.

## r. Adjustment and maintenance operations

Must be performed by skilled technicians.

In connection with demands for compensation, Systemair must have full and unhindered access to all relevant reporting on service, repair, modification and use since the unit was transferred from Systemair to a transport company at the Systemair factory. It is a condition for compensation that maintenance outlined on the following pages has as a minimum been performed.

### r.1 Shutdown of the unit to a safe state.

Switch the unit to OFF on the control panel. Switch off the automatic circuit breakers and block them by padlocks. See the example in the illustration below about how to place a padlock on each automatic circuit breaker.

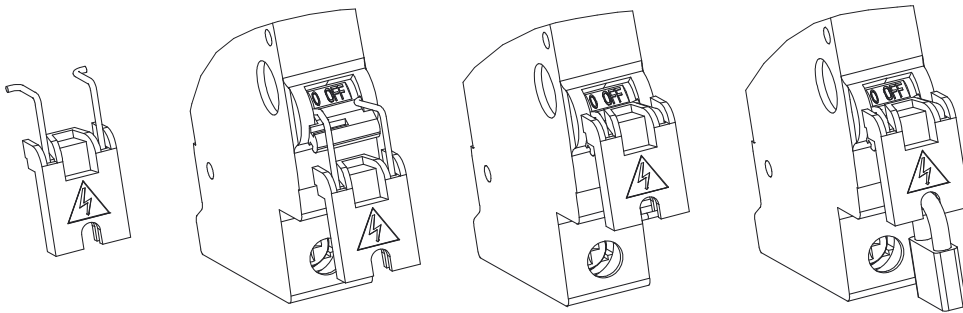

Switch on the lamps for light during the maintenance activities. Lamps is an accessory.

Use the start-up procedure described in section k, when the maintenance activities are completed.

## r.2 Recommended maintenance intervals

Function	Maintenance	Number per year
<b>Unit casing</b>	Cleaning of the unit casing.	1
	Control of rubber seals on doors and between sections.	1
<b>Filters</b>	Control of filters. Change the filters when maximum pressure is exceeded. To maintain the calculated SFPv values, filters with similar performance must replace the factory-mounted filters. Start pressures of factory-mounted filters appear from Annex 2 that is always provided in a cover placed inside the air handling unit when the air handling unit is delivered to the final site. Annex 2 is also always available from Systemair if you can inform us of the production number of the air handling unit. For health reasons, the filters must always be changed two years after installation in the unit.	1
	Control of rubber seals. Control of the system with lateral locking rails and handles on TIME and DV10 – DV150. Control of the filter bank frames with fasteners on DV190 and DV240.	1
	Test of filter guards	1
<b>Fans</b>	Cleaning of all parts.	1
	Check motors and bearings	1
	Check that the impellers are rotating without dissonance.	1
	Check that anti-vibration mounts are intact.	1
	Check that the unit is operation without vibrations after the cleaning, overhaul and maintenance.	1
<b>Rotary heat exchanger</b>	Check that leakage and dirt accumulation is insignificant Standard rotors may only be cleaned by gentle vacuum cleaning or by gentle blowing of compressed air. Rotors may only be cleaned by high-pressure water if it is one of the very few special rotors that are ordered and built for this.	1
	Check that the rotor can turn freely and easily manually with a hand when the belt is removed from the drive	1
	Check belt tension and replace belt in case of visible wear.	1
<b>Plate heat exchanger</b>	Check bypass function and sequence for de-icing	1
<b>Run-around heat exchanger</b>	Check the exchanger function and test the frost protection. The glycol must be without additives and must not be auto glycol. Coils may only be cleaned by gentle vacuum cleaning or by gentle blowing of compressed air. Coils may only be cleaned by high-pressure water if it is one of the very few special batteries that are ordered and built for this.	1

Function	Maintenance	Number per year
<b>Dampers</b>	Test the operation.	1
	Visual inspection of seals and tightness when closed.	1
<b>Hot water battery</b>	Check the dirt accumulation and clean, if needed. Coils may only be cleaned by gentle vacuum cleaning or by gentle blowing of compressed air. Coils may only be cleaned by high-pressure water if it is one of the very few special batteries that are ordered and built for this.	1
	Bleeding, if needed.	1
	Test of frost protection sequence	1
	Test of circulation pump	1
<b>Electric heating battery</b>	Check dirt accumulation and clean, if needed.	1
	Test the function of the system with the fuses for the safety.	1
<b>Cooling battery</b>	Check dirt accumulation and clean, if needed. Coils may only be cleaned by gentle vacuum cleaning or by gentle blowing of compressed air. Coils may only be cleaned by high-pressure water if it is one of the very few special batteries that are ordered and built for this.	1
	Test the frost protection (glycol)	1
<b>Heat pump unit</b>	Mandatory annual control of the heat pump system. Must be done by certified technician from a certified company.	1
<b>Condensate drain</b>	Cleaning of tray, water trap and outlet. Check the electrical heating between insulation and pipes, if installed.	1

### **r.3. Filters – always replace filters with new filters with the same characteristics to maintain SFP value**

Filters in supply air and in extract air always have the same sizes of frames and the number of filters for supply air and extract air are always the same. REMEMBER to order filters for supply air as well as for extract air.

To maintain the factory-calculated SFP values for the air-handling unit, it is very important that filters with the same characteristics for start pressure as well as lifetime replace factory-mounted filters.

To achieve the most favourable SFP values, the factory-mounted filters represent the lowest achievable start pressure as well as the longest achievable lifetime. If other filters with higher start pressure and shorter lifetime replace the factory-mounted filters, the user will experience smaller airflow and/or consumption of more electricity, and the SFPv value calculated by Systemair according to the Eurovent certification will not be achieved. Poor\_SFPv values will be detected by tests according to commissioning standards, DGNB, LEED or BREEAM sustainability standards and locally defined performance standards (the SFPv is with new clean filters).

Filter frame for bag filters must be of NON-PVC plastic to ensure safe disposal by incineration.

For each individual air handling unit you will find the data for the factory-mounted filters in Annex 2 that is always provided in a cover placed inside the air handling unit when the air handling unit is delivered to the final site. Annex 2 is also always available from Systemair if you can inform us of the production number of the air handling unit. The production number is always printed on the so-called machine card that is attached to the unit. You will find an example of this machine card in section d.2.1 of this manual.

The factory-mounted filters comply with indoor air quality demands of customers and with the SFP values according to local legislation.

These air handling units are available with filters that comply with the below-mentioned filter classes:

- G4
- M5
- M6
- F7
- F7 CityFlo
- F8
- F9

### r.3.1 Bag filters – the number of filters and the sizes of the frames

Size of air handling unit	Numbers of filters and sizes of frames (Width x Height) in mm.
10	1 x (792x392)
15	2 x (490x392)
20	1 x (490x490) 1 x (592x490)
25	2 x (592x592)
30	1 x (592x592) 1 x (490x592) 1 x (287x592)
40	3 x (490x742)
50	3 x (592x490) 3 x (592x287)
60	8 x (490x490)
80	4 x (490x592) 4 x (490x490)
100	4 x (592x592) 4 x (490x592)
120	4 x (592x592) 4 x (592x490) 4 x (592x287)
150	9 x (592x490) 6 x (490x490)
190	15 x (592x592)
240	15 x (592x592) 3 x (287x592) 5 x (592x287)

NOTE that special sizes of filters are available from Camfil.

Depth of filter frame must be 25 mm to ensure a complete airtight sealing around the AHU filter frame.

### r.3.2 Panel filters – the number of filters and the sizes of the frames

Size of air handling unit	Numbers of filters and sizes of frames (Width x Height x Depth) in mm
10	2 x [376x376x44]
15	2 x [448x448x44]
20	1 x [241x495x44] 1 x [495x495x44] 1 x [391x495x44]
25	2 x [445x622x44] 1 x [391x622x44]
30	3 x [445x622x44]
40	6 x [495x368x44]
50	6 x [622x391x44]
60	8 x [495x495x44]
80	4 x [495x495x44] 4 x [495x597x44]
100	10 x [445x622x44]
120	15 x [495x445x44]
150	21 x [391x495x44]
190	15 x [592x592x25]
240	15 x [592x592x25] 3 x [287x592x25] 5 x [592x287x25]

NOTE that special sizes of filters are available from Camfil.

### r.3.3 Bag filters

Release the bag filter cells by activating the handles and pull out the filter cells of the unit casing. The frame profiles are to be cleaned and all seals checked for damage. The handles and locking guide rails are also to be checked to ensure that they can operate unobstructed. The new filter bags must be pushed carefully into the unit in order to ensure that they are sealed properly. The various filter sizes should be placed in an order corresponding to the way in which the unit is designed, and the filters must have vertical bags.

### r.3.4 Panel filters

The filter cell guide rails are to be cleaned before fitting the new filters.

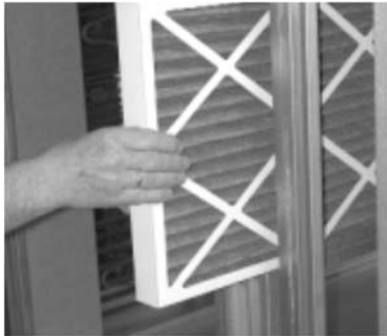

## r. 4 Other functions to maintain

### r. 4.1 The unit

The unit should be cleaned once a year when operating with normal air quality for comfort ventilation with no special hygiene requirements.

To clean the unit, dry it off with a dry cloth, or use water mixed with a non-corrosive cleaning medium.

Any corrosion i.e. at the filters should be cleaned off immediately, and the surface treated.

In special operating conditions, where the air is aggressive or very humid, for example, or where there are special hygiene requirements, the unit shall be cleaned more frequently as required.

Cleaning medium and method should be adapted to the relevant conditions. Any corrosion should be cleaned off immediately, and the surface treated.

Closing mechanisms are to be lubricated at least once a year. Synthetic door hinges are service free. Seals around inspection doors are to be cleaned at least once a year and are to be checked for leakage.

It is recommended to treat the seals with a moisture repellent agent. Connecting pieces for the unit sections, including the Disc-Lock types, are to be checked for tightness at least once a year.

All seals are to be inspected at least once a year and are to be repaired if necessary.

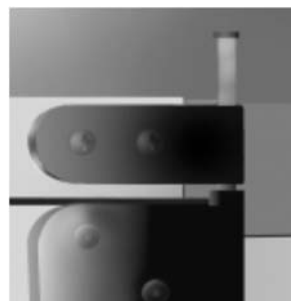

Grilles for air intake and exhaust air outlet are to be cleaned at least once a year to prevent blockage.



#### r. 4.2 Dampers

Rubber seals between the damper blades themselves and between the damper blades and the frame are to be checked once a year. These seals are not to be lubricated or treated in any other way.

Each damper blade is connected by a pivoting system. The steel rods and brass bushes do not require lubrication.

The damper blades are fitted with synthetic bearings requiring no lubrication. Air-tightness of the damper, when the damper motor is in the closed position, must be visually checked once a year. The damper motor is to be adjusted if the damper does not close tightly.

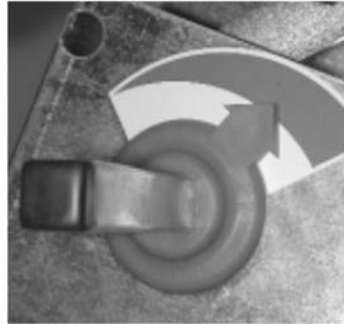
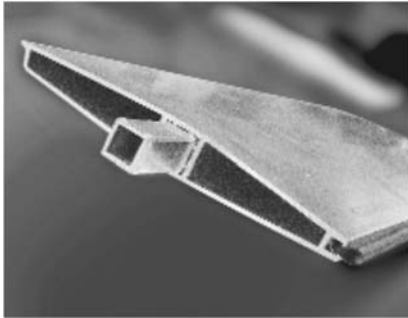

#### r. 4.3 Rotary heat exchanger DVC



##### r. 4.3.1 Rotor

The rotor is to be checked at least once a year to ensure that it can turn freely and easily. This can be done by removing the belt drive at the motor and then turning the rotor manually with a hand on the peripheral rotor casing. At the same time the brush seals are to be checked for damage. The bearings are factory lubricated and do not require any service lubrication. During operation the rotor can become dirty. The rotor can be cleaned by blowing through with compressed air.

To ease inspection and service the rotor can be pulled out of the sizes 10, 15, 20, 25 og 30.

#### **r. 4.3.2 Motor and belt drive**

The bearings are factory lubricated and do not require any service lubrication. The belt drive is to be checked for correct tightness and that it is undamaged. On smaller AHU, the rotor is fitted with an elastic belt drive and supplied with a reserve belt on the rotor. This belt drive does not require service and cannot be shortened. A new belt can be fitted using specialist tools. On larger heat exchangers the rotor has a V-belt with a belt connector. If the belt is no longer tight, it must be shortened to a length which enables the motor base frame tightening spring to hold the belt tight. If new screws are used for the belt connector, they must not have a length which exceeds the thickness of the belt and connector. Remove the excess, if any, with a file.

#### **r. 4.4 Cross flow and counter flow exchanger**

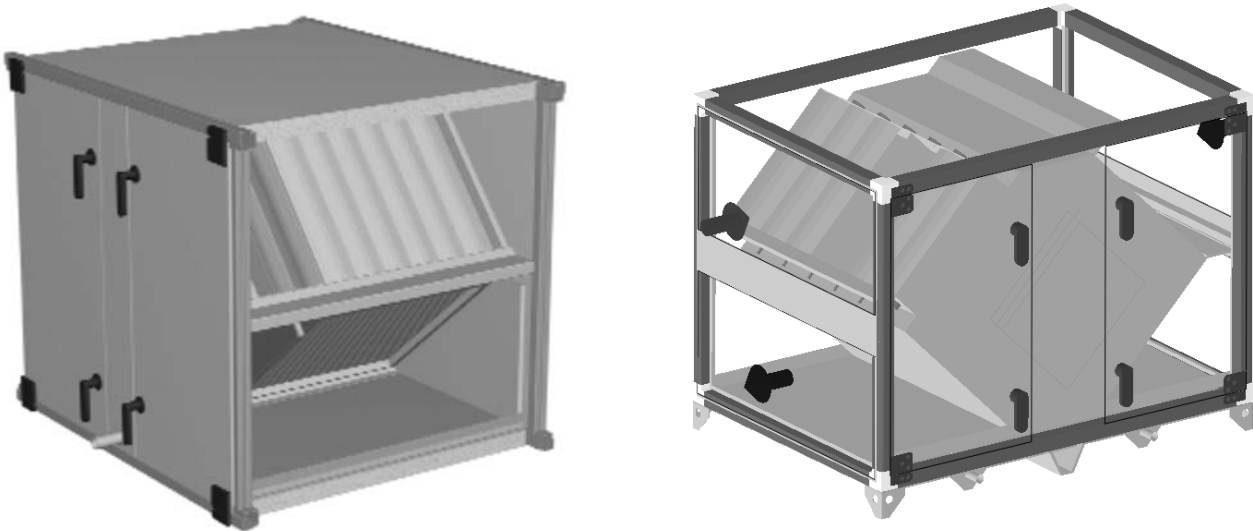

Once a year the edges of the heat exchanger plates are to be checked for cleanliness and damage. If there is dust on the edges of the plates, remove it with a soft brush. If grease or other such substances are present, then the edges must be washed using grease dissolving detergents.

##### **r. 4.4.1 By-pass damper**

The damper blades are fitted with synthetic bearings requiring no lubrication. Each damper blade is connected by a pivoting system. The steel rods and brass bushes do not require lubrication. Air-tightness of the dampers, when the damper motor is in the closed position, must be visually checked once a year. The damper motor is to be adjusted if the damper does not close tightly.

##### **r. 4.4.2 Condensate water drain**

Once a year clean the drip tray beneath the heat exchanger, as well as the drain and the water trap. Take care that there is sufficient water in the water trap. If a droplet eliminator has been fitted, this must be checked once a year and cleaned if necessary.

#### r. 4.5 Run-around heat exchanger DVR

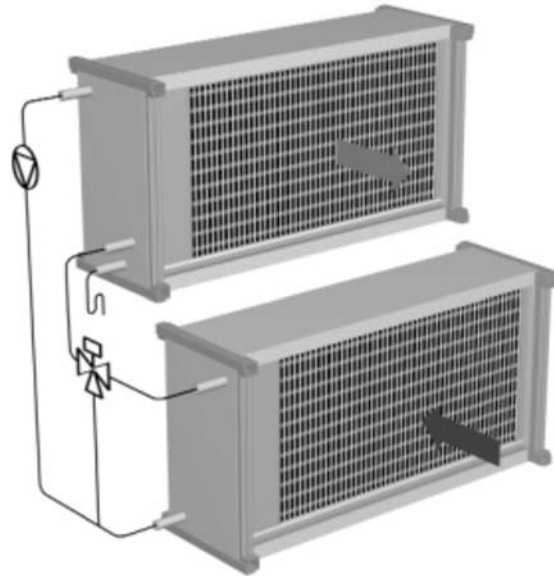

A heat recovery system of this type consists of a heating coil in the supply air- flow and a cooling coil in the exhaust air- flow. After an extended running period (normally a few years) dust particles can accumulate on the surface of the coils. This can reduce the efficiency of the coils. Cleaning must be carried out with the utmost care to ensure that the coil fins are not damaged.

The piping system must be vented once a year as air in the system can significantly reduce the capacity of the coils.

##### r. 4.5.1 Pump and pressure expansion

The service instructions issued by the pump manufacturer must be followed. The pressure expansion system must be checked once a year. If necessary, the pressure must be increased to the correct level.

##### r. 4.5.2 Condensate water drain

Once a year clean the drip tray beneath the heat exchanger, as well as the drain and the water trap. Take care that there is sufficient water in the water trap. If a droplet eliminator has been fitted to the cooling coil, this must be checked once a year and cleaned if necessary.

#### r. 4.6 Heating coil DVH, cooling coil DVK and change over coil DVHK

After an extended running period (normally a few years) dust particles can accumulate on the surface of the coil. This can reduce the efficiency of the coil. Cleaning must be carried out with the utmost care to ensure that the coil fins are not damaged. The piping system must be vented once a year as air in the system can significantly reduce the capacity of the coil.

##### r. 4.6.1 Heating battery

Check that the frost protection system is fully operational. A battery may burst due to frost if the frost protection system is not operational.

##### r. 4.6.2 Cooling battery

Once a year clean the drip tray beneath the cooling coil, as well as the drain and the water trap. Take care that there is sufficient water in the water trap. If a droplet eliminator has been fitted to the cooling coil, this must be checked once a year and cleaned if necessary.

#### **r. 4.6.3 Electric heating battery**

Check that the built-in safety thermostat with an automatic reset function and the overheat thermostat with manual resetting are fully operational.



#### **r. 4.7 Plug fans DVE**

Dust can accumulate on the fan impeller which can cause imbalance and vibrations. The fan impeller must therefore be checked once a year and cleaned, if necessary. Anti-vibration mounts and flexible connections should be checked at the same time. If the anti-vibration mounts are damaged in any way they must be replaced.

##### **r. 4.7.1 Motor**

The motor are usually fitted with factory lubricated bearings which require no further lubrication. Larger motors can be fitted with greasing nipples and bearings which require regular lubrication. Lubricating these types of bearings must be carried out according to the manufacturer's instructions.

#### **r. 4.8 Silencer DVD**



During operation dust particles can accumulate on the surface of the baffles. Silencers that are designed for dry and wet cleaning are fitted with baffles that can be extracted from the unit casing. Large inspection doors give access to easily extraction of the baffles. Baffles designed for dry cleaning can be cleaned using a soft brush or they can be vacuum cleaned. Baffles designed for wet cleaning can be washed down using a soft brush and soapy water. The detergent used must be non-aggressive. After washing, the baffles must be wiped dry with a cloth. Remember to clean the inside surface of the unit casing before refitting the baffles.

#### r. 4.9 Outdoor air section DVY



Dust and dirt can accumulate in this section. Large inspection doors give access for cleaning.

#### r. 4.10 Heat pump unit – DVU-HP

Mandatory annual control must be done by certified technicians from a certified company. See further description in annex 10 and 11.

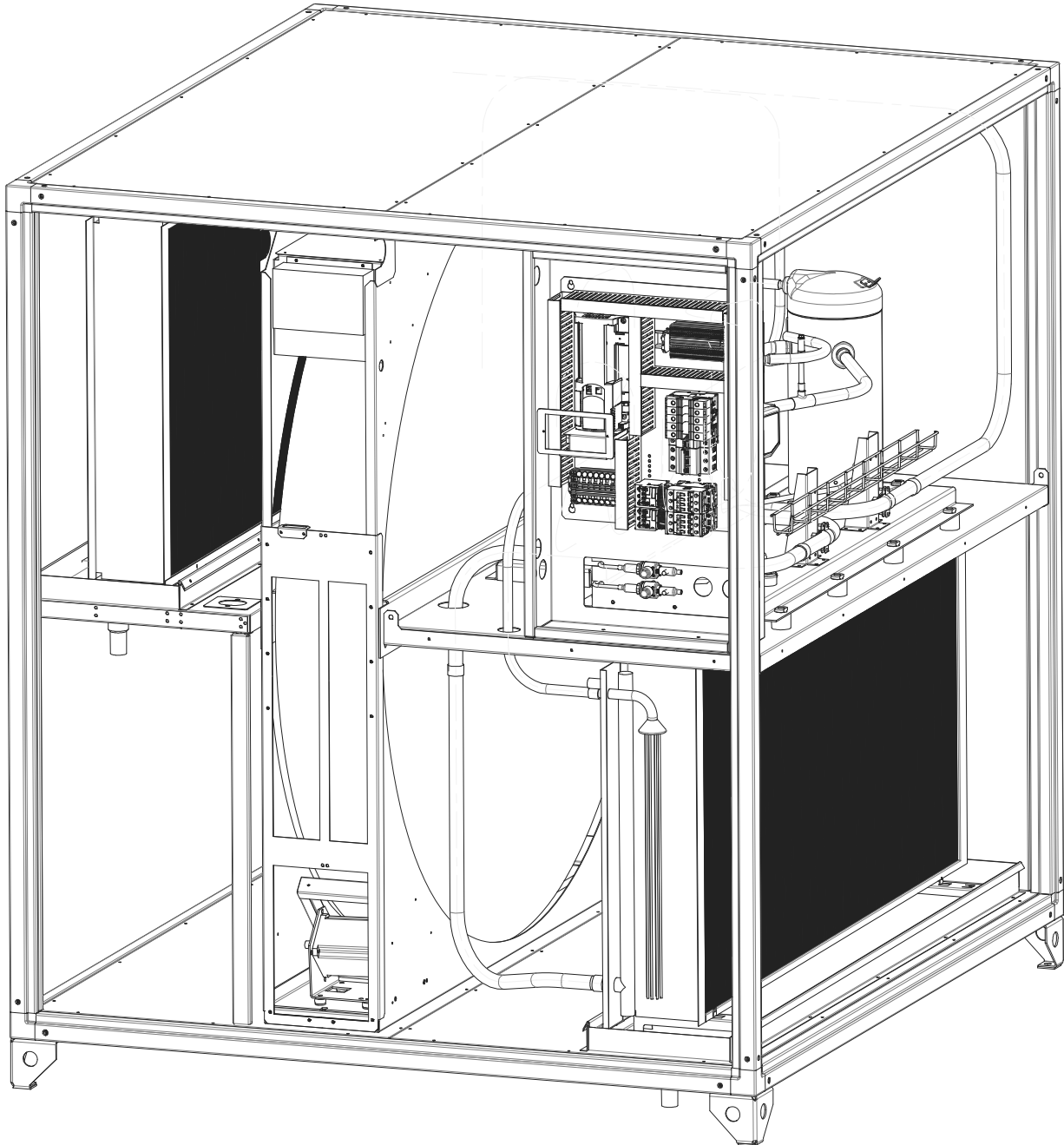

## s. Instructions designed to enable adjustment and maintenance to be carried out safely, including the protective measures that should be taken during these operations

### s.1. Protective measures and additional protective measures

Adjustment and maintenance must be done by skilled technicians – usually based on service contracts for some years or long-term ESCO contracts.

The units are provided with guards to avoid unintended hazards and injury because of rotating parts in the unit. The potential sources of harm are the fans with fast rotating impellers. Hazards from the impellers are obvious during operation, but when power is cut-off, the impellers are still potential hazards due to after-run for at least 20 seconds. Notice that even cut-off the impellers are still potential hazards.

The fan guard's are the inspection doors and the doors are provided with locks. Inside the doors are additional protection installed – guards that only can be removed by use of tools.

Other motor-driven parts are dampers with damper motors and rotary heat exchangers, but the movement is so slow that guard measures are not necessary. Just keep your hands away from places with risk of injury. Use particulate respirator when filters are replaced.

#### s.1.1 Necessary protection measures prior to start-up.

Ensure that all protection measures are installed correct before start-up.

##### s.1.1.1 Design of protection measures

Inside the doors are additional protection installed – guards that only can be removed by use of tools.

##### s.1.1.2 Configuration of frequency converters with installed guard

A frequency converter is mounted beside the fan in some units. If the configuration of frequency is carried out with the fan in operation, the guard must be installed for safety reasons and a long cable must be installed between the frequency converter inside the unit and the control panel outside the unit.

#### s.1.2 Safe adjustment and maintenance

Before maintenance and repair, the unit must be switched off by switching off the automatic circuit breakers and block them by padlocks.. See the illustration below about how to place a padlock on each automatic circuit breaker. **Note that lamps must be switched on during maintenance** (lamps are an accessory – only installed, if ordered).

Use cut-resistant gloves for protection against injury from sharp metal plate edges. Use CE-marked gloves for this purpose. Use helmet during maintenance work in the unit.

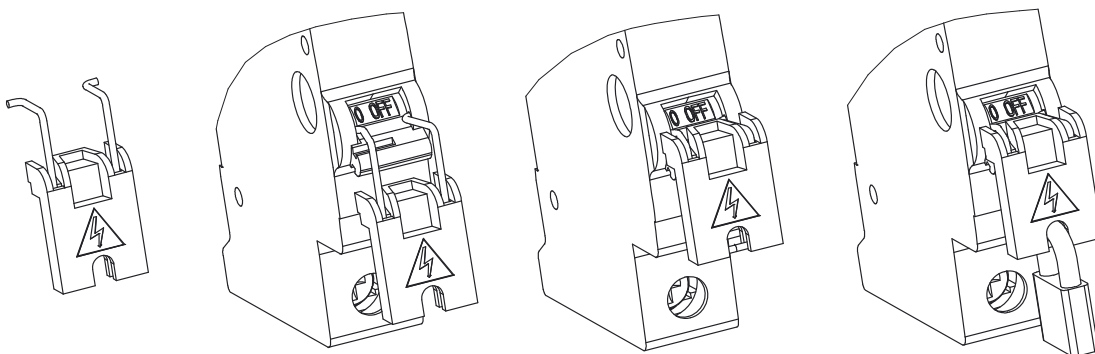

### **s.1.3 Personal protective equipment for maintenance staff – health and safety**

Use the below-mentioned personal protective equipment for maintenance:

- Cut-resistant gloves for protection against injury from sharp metal plate edges. Use CE-marked gloves for this purpose.
- Helmet
- Particulate respirator – maintenance free including foam face-seal and adjustable pre-threaded headbands – for replacing filters.
- Padlock for locking the above mentioned automatic circuit breakers.
- Permanent magnet motor. The shaft must be blocked during repairs and maintenance of the electric system (the motor generates electricity by rotation – for example that the wind and thermic drives the fan/motor).

## **t. The specifications of the spare parts to be used, when these affect the health and safety of operators**

DV units are operating automatically. Operators can control the unit by the control panel.

### **t.1 Spare parts - Mechanical**

Annex 3 - available on demand

### **t.2 Spare parts - Electrical**

Annex 3 – available on demand

## **u. Information on airborne noise emissions exceeding 70 dB(A)**

Due to the design and construction of the units the (A) weighed sound pressure level from fans and other components do not exceed 70 dB (A) outside the units.





# Annex for the User Manual

## Air Handling Units

### Danvent DV

#### Without control system

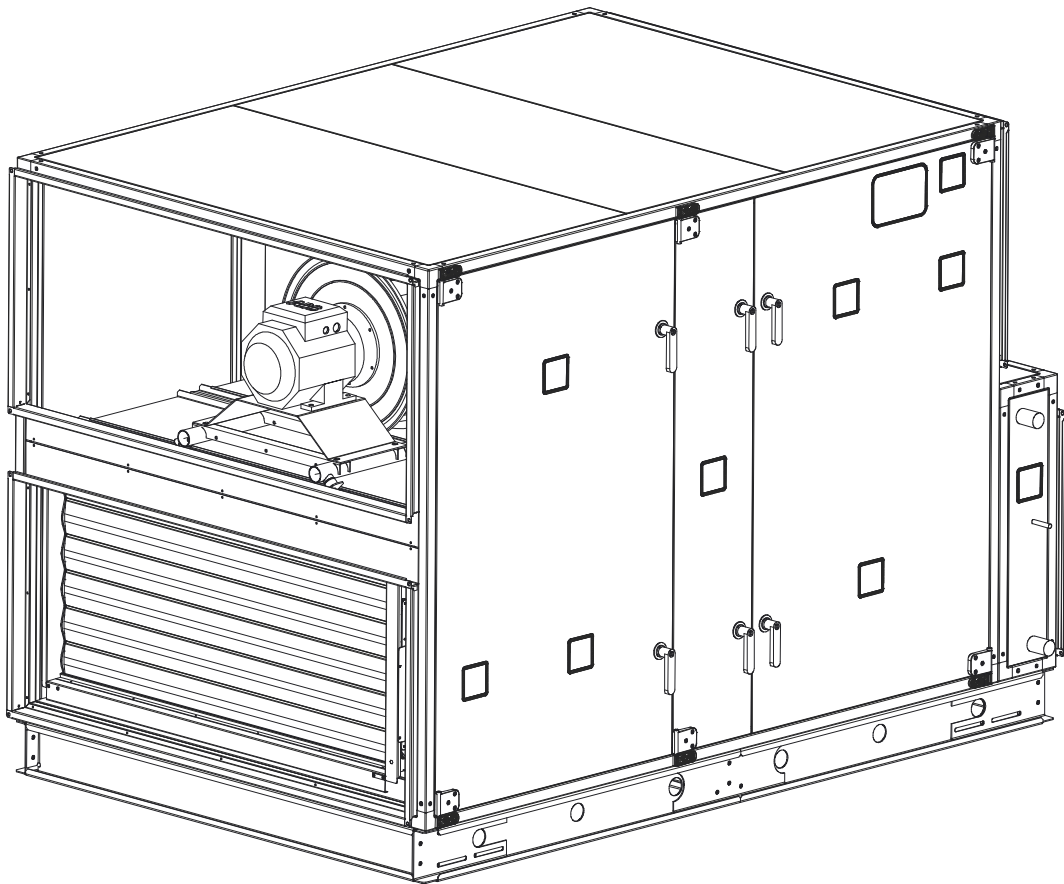

Version 1.01.13

---

## **Overview of annexes**

Annexes 1, 2, 3 and 13 are enclosed in a separate cover.

### **Annex 1 Declaration of conformity with unique production number**

Printed on separate page and delivered with every unit. Enclosed in separate cover.

### **Annex 2 Technical data – unique data for every unit**

Printed on separate pages and delivered with every unit. Enclosed in separate cover.

### **Annex 3 spare part lists**

Printed on separate pages but not delivered with every unit. Available on demand.

### **Annex 4 Assemble base frames – height 150 mm for units in the sizes 10-40**

### **Annex 5 Assemble base frames – height 150 mm for units in the sizes 50-150**

### **Annex 6 Assemble base frames – height 250 mm for units in the sizes 10-40**

### **Annex 7 Assemble base frames – height 250 mm for units in the sizes 50-150**

### **Annex 8 Installation of steel roof in the sizes 10-150**

### **Annex 9 Rotary exchanger – speed control and assembly of divided rotor**

### **Annex 10 Heat pump unit – DVU-HP**

### **Annex 11 Menu for internal controller in the heat pump unit**

### **Annex 12 Connection of fan motor and set-up manual for Danfoss VLT FC101 frequency converter**

## **Annex 13 Commissioning protocol – proposal (receipt for hand-over)**

Printed on separate pages and delivered with every unit. Enclosed in separate cover

**Annex 4. Assemble base frames - height 150 mm for units sizes 10-40**

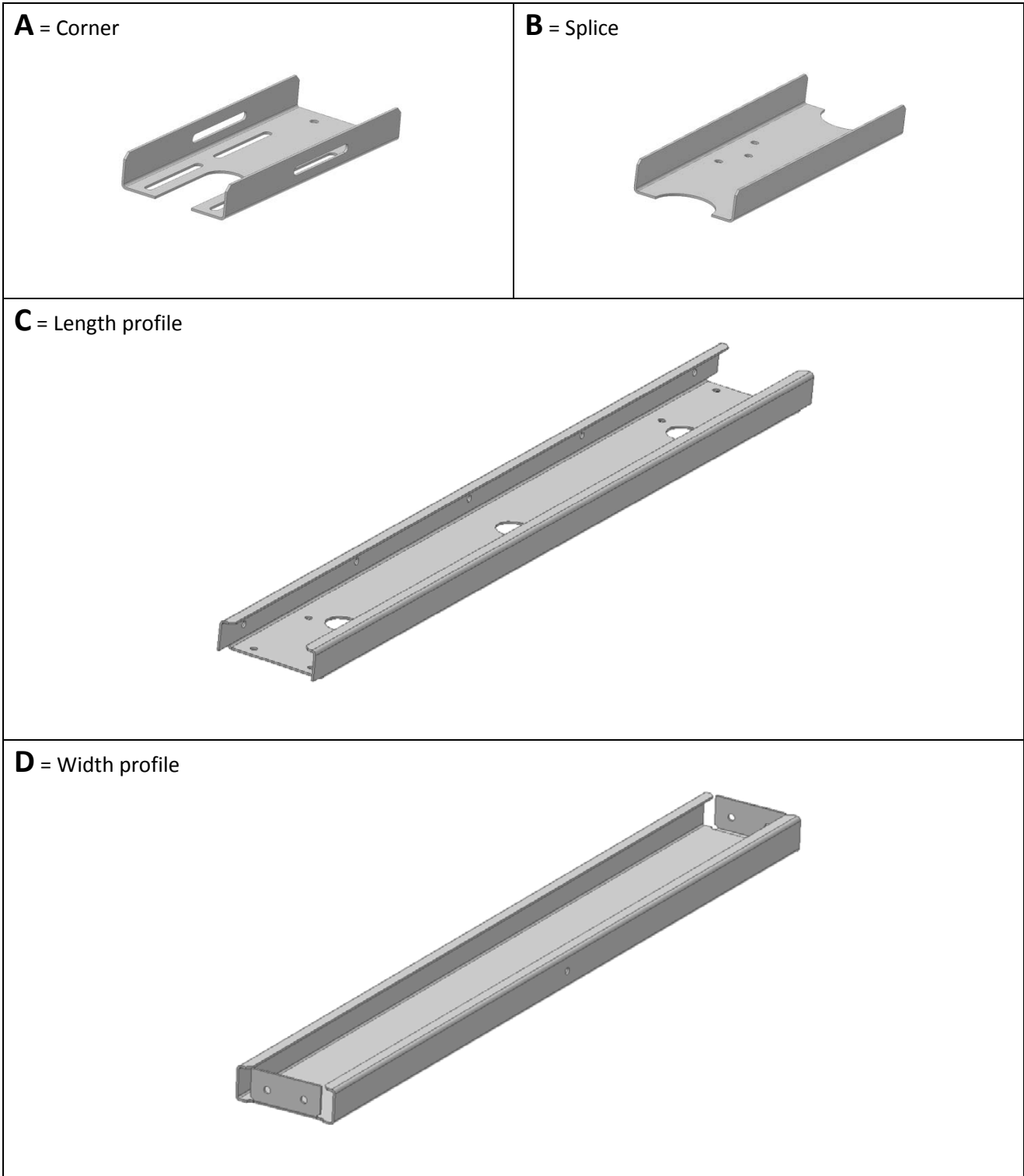

#### 4.1 Base frame length 720 – 2420 [mm] Unit size 10-40

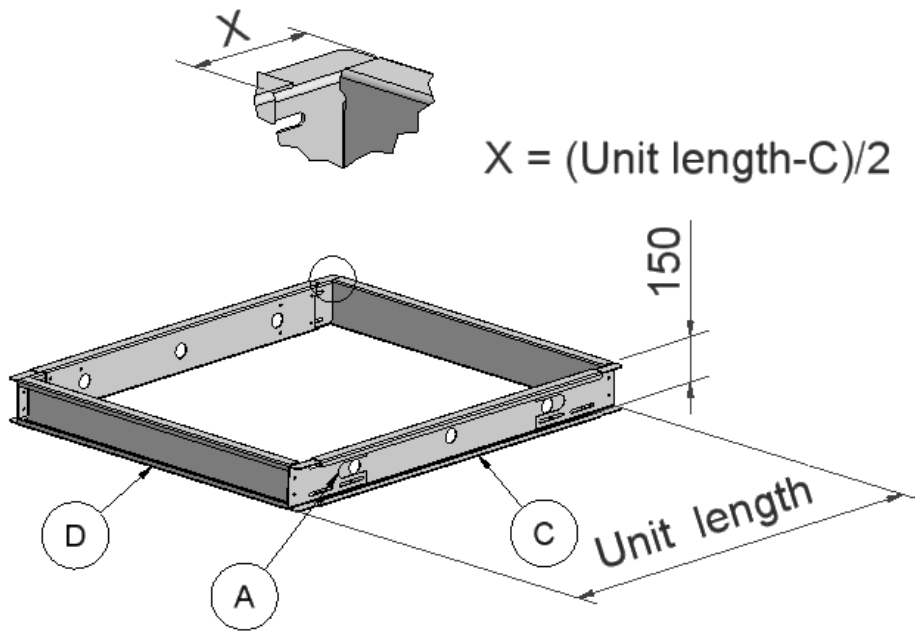

##### Width profile type D

<i>Unit size</i>	<i>Quantity</i>	<i>Length [mm]</i>
DV-10	2	876
DV-15	2	1026
DV-20	2	1176
DV-25	2	1326
DV-30	2	1476
DV-40	2	1626

##### C

<i>Frame length [mm]</i>	<i>Quantity</i>	<i>Length [mm]</i>	<b>A</b>
			<i>Quantity</i>
700-770	2	520	4
770-920	2	670	4
920-1070	2	820	4
1070-1220	2	970	4
1220-1370	2	1120	4
1370-1520	2	1270	4
1520-1670	2	1420	4
1670-1820	2	1570	4
1820-1970	2	1720	4
1970-2120	2	1870	4
2120-2270	2	2020	4
2270-2420	2	2170	4

#### 4.2 Base frame length 2420 – 4590 [mm] Unit size 10-40

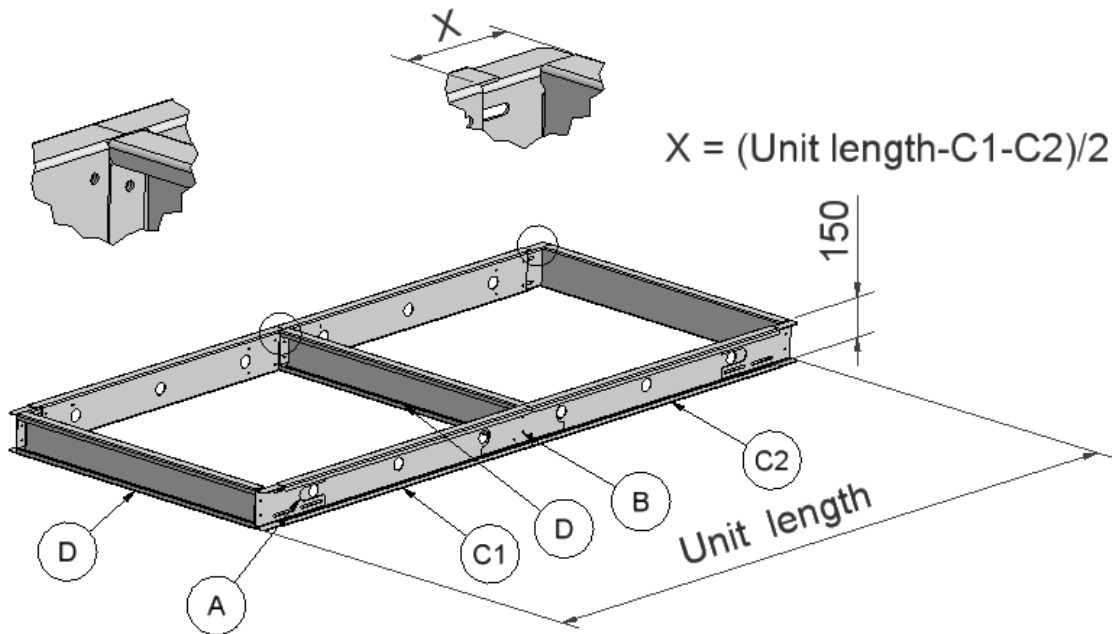

#### Width profile type D

Unit size	Quantity	Length [mm]
DV-10	3	876
DV-15	3	1026
DV-20	3	1176
DV-25	3	1326
DV-30	3	1476
DV-40	3	1626

Frame length [mm]	C1		C2		A	B
	Quantity	Length [mm]	Quantity	Length [mm]	Quantity	Quantity
2420-2570	2	1120	2	1200	4	2
2570-2640	2	1270	2	1200	4	2
2640-2790	2	1270	2	1270	4	2
2790-2940	2	1270	2	1420	4	2
2940-3090	2	1420	2	1420	4	2
3090-3240	2	1420	2	1570	4	2
3240-3390	2	1570	2	1570	4	2
3390-3540	2	1570	2	1720	4	2
3540-3690	2	1720	2	1720	4	2
3690-3840	2	1720	2	1870	4	2
3840-3990	2	1870	2	1870	4	2
3990-4140	2	1870	2	2020	4	2
4140-4290	2	2020	2	2020	4	2
4290-4440	2	2020	2	2170	4	2
4440-4590	2	2170	2	2170	4	2

### 4.3 Base frame length 4590 – 6200 [mm] Unit size 10-40

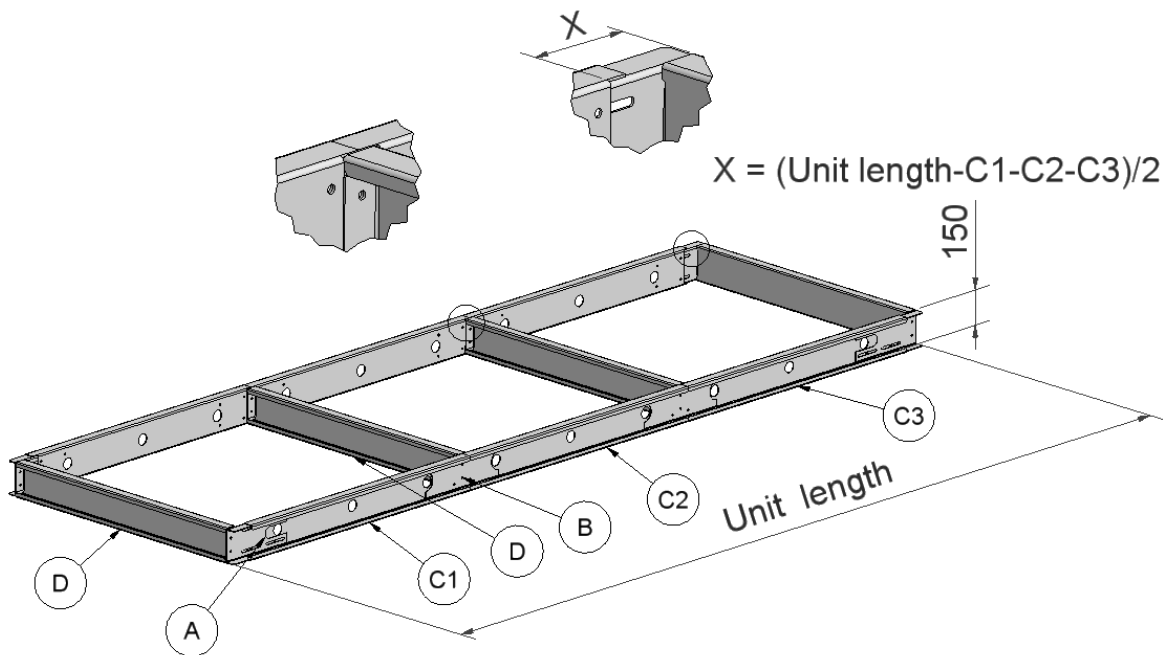



#### Width profile type D

Unit size	Quantity	Length [mm]
DV-10	4	876
DV-15	4	1026
DV-20	4	1176
DV-25	4	1326
DV-30	4	1476
DV-40	4	1626

Frame length [mm]	C1		C2		C3		A	B
	Quantity	Length [mm]	Quantity	Length [mm]	Number	Length [mm]	Qty	Qty
4590-4740	2	1420	2	1500	2	1570	4	4
4740-4890	2	1570	2	1570	2	1500	4	4
4890-5040	2	1720	2	1500	2	1570	4	4
5040-5110	2	1720	2	1720	2	1500	4	4
5110-5260	2	1720	2	1720	2	1570	4	4
5260-5410	2	1720	2	1720	2	1720	4	4
5410-5560	2	1870	2	1720	2	1720	4	4
5560-5710	2	1870	2	1870	2	1720	4	4
5710-5860	2	1870	2	1870	2	1870	4	4
5860-6010	2	2020	2	1870	2	1870	4	4
6010-6160	2	2020	2	2020	2	1870	4	4
6160-6200	2	2020	2	2020	2	2020	4	4

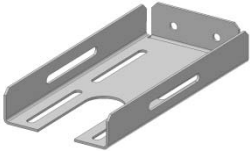
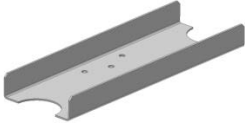
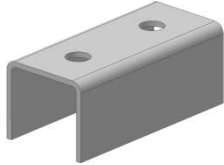

**Annex 5. Assemble base frames - height 150 mm for units sizes 50-150**

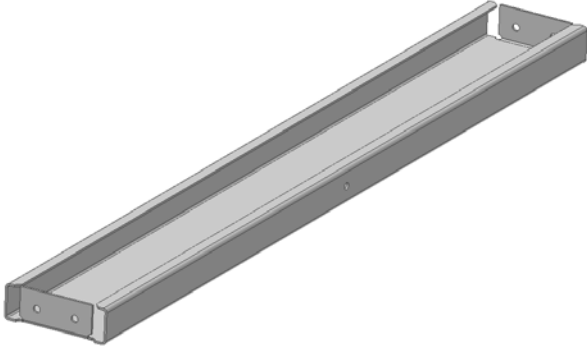
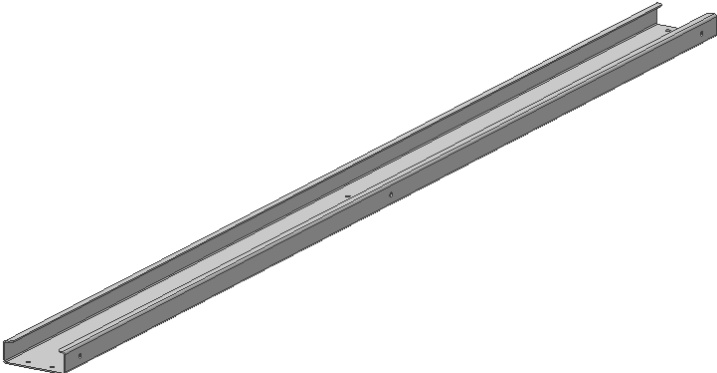
<p><b>A = Corner</b></p> 	<p><b>B = Splice</b></p> 	<p><b>C = Spacer</b></p> 
<p><b>D = Length profile</b></p> 		
<p><b>E = Spacer profile</b></p> 		
<p><b>F = Width profile</b></p> 		

### 5.1 Base frame length 720 – 2420 [mm] Unit size 50-DV150

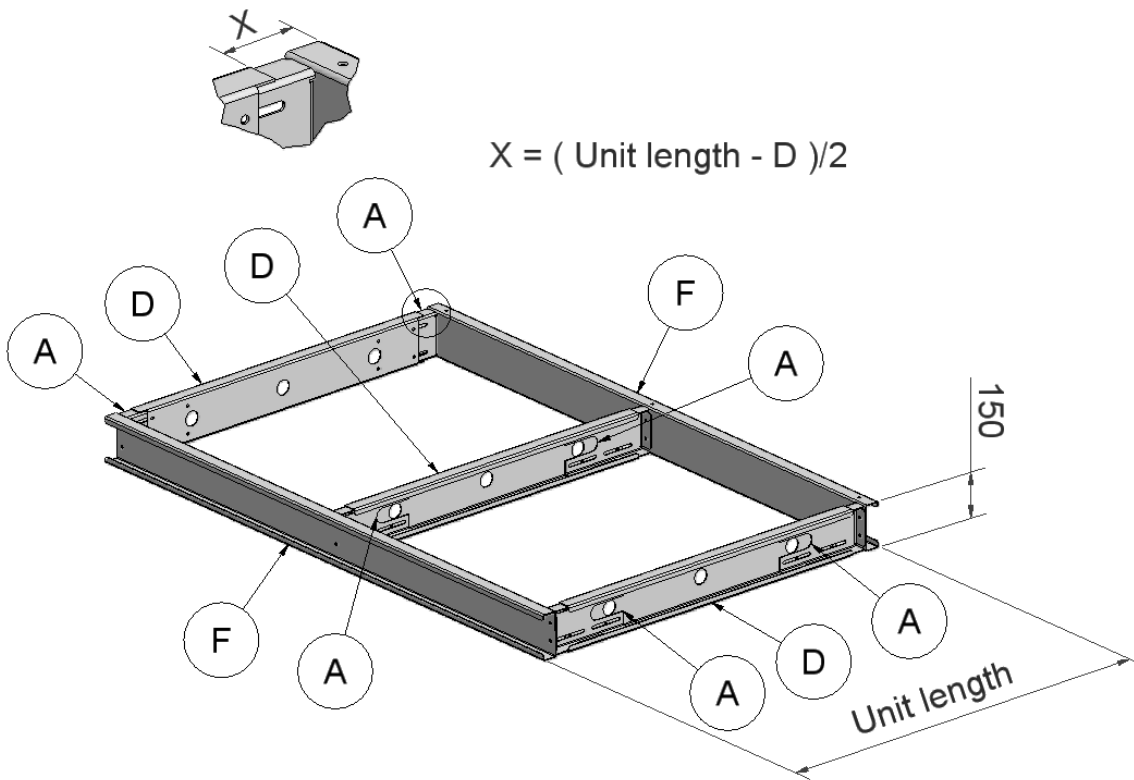

#### Width profile type F

Unit size	Quantity	Length [mm]
DV-50	2	2020
DV-60	2	2170
DV-80	2	2170
DV-100	2	2370
DV-120	2	2590
DV-150	2	2890

Frame length [mm]	Quantity	D	A
		Length [mm]	Quantity
700-770	3	520	6
770-920	3	670	6
920-1070	3	820	6
1070-1220	3	970	6
1220-1370	3	1120	6
1370-1520	3	1270	6
1520-1670	3	1420	6
1670-1820	3	1570	6
1820-1970	3	1720	6
1970-2120	3	1870	6
2120-2270	3	2020	6
2270-2420	3	2170	6

## 5.2 Base frame length 2420 – 4590 [mm] Unit size 50-150

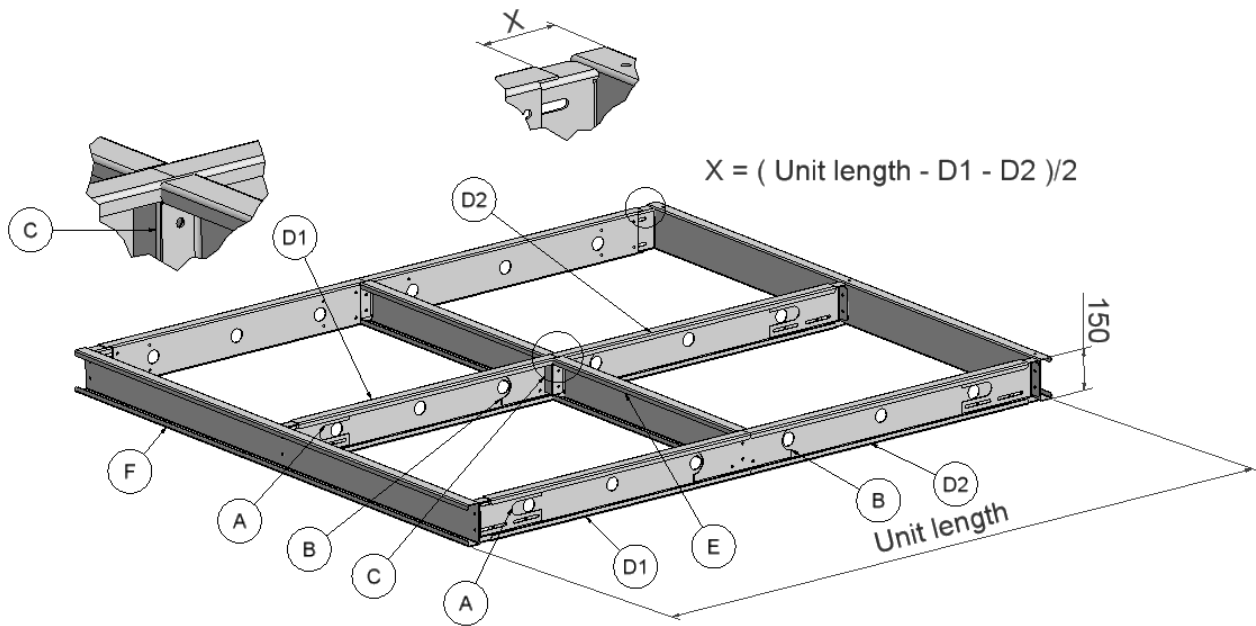

Width profile type F			Width profile type E	
Unit size	Quantity	Length [mm]	Length [mm]	
DV-50	2	2020	940	
DV-60	2	2170	1015	
DV-80	2	2170	1015	
DV-100	2	2370	1115	
DV-120	2	2590	1225	
DV-150	2	2890	1375	

Frame length [mm]	D1		D2		A	B	C	E
	Quantity	Length [mm]	Quantity	Length [mm]	Quantity	Quantity	Quantity	Quantity
2420-2570	3	1120	3	1200	6	3	1	2
2570-2640	3	1270	3	1200	6	3	1	2
2640-2790	3	1270	3	1270	6	3	1	2
2790-2940	3	1270	3	1420	6	3	1	2
2940-3090	3	1420	3	1420	6	3	1	2
3090-3240	3	1420	3	1570	6	3	1	2
3240-3390	3	1570	3	1570	6	3	1	2
3390-3540	3	1570	3	1720	6	3	1	2
3540-3690	3	1720	3	1720	6	3	1	2
3690-3840	3	1720	3	1870	6	3	1	2
3840-3990	3	1870	3	1870	6	3	1	2
3990-4140	3	1870	3	2020	6	3	1	2
4140-4290	3	2020	3	2020	6	3	1	2
4290-4440	3	2020	3	2170	6	3	1	2
4440-4590	3	2170	3	2170	6	3	1	2

### 5.3 Base frame length 4590 – 6200 [mm] Unit size 50-150

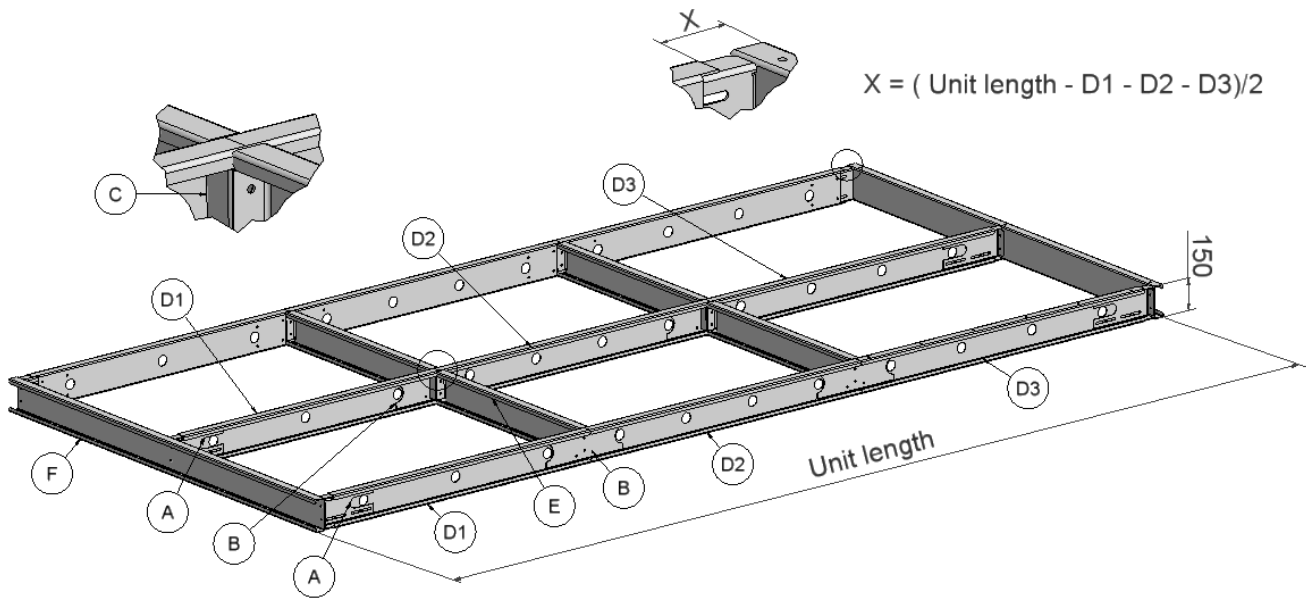

Width profile type F			Width profile type E	
Unit size	Quantity	Length [mm]	Length [mm]	
DV-50	2	2020	940	
DV-60	2	2170	1015	
DV-80	2	2170	1015	
DV-100	2	2370	1115	
DV-120	2	2590	1225	
DV-150	2	2890	1375	

Frame length [mm]	Qty	D1		D2		D3		A	B	C	E
		Qty	Length [mm]	Qty	Length [mm]	Qty	Length [mm]	Qty	Qty/	Qty	Qty
4590-4740	3	3	1420	3	1500	3	1570	6	6	2	4
4740-4890	3	3	1570	3	1570	3	1500	6	6	2	4
4890-5040	3	3	1720	3	1500	3	1570	6	6	2	4
5040-5110	3	3	1720	3	1720	3	1500	6	6	2	4
5110-5260	3	3	1720	3	1720	3	1570	6	6	2	4
5260-5410	3	3	1720	3	1720	3	1720	6	6	2	4
5410-5560	3	3	1870	3	1720	3	1720	6	6	2	4
5560-5710	3	3	1870	3	1870	3	1720	6	6	2	4
5710-5860	3	3	1870	3	1870	3	1870	6	6	2	4
5860-6010	3	3	2020	3	1870	3	1870	6	6	2	4
6010-6160	3	3	2020	3	2020	3	1870	6	6	2	4
6160-6200	3	3	2020	3	2020	3	2020	6	6	2	4

**Annex 6. Assemble base frames - height 250 mm for units sizes 10-40**

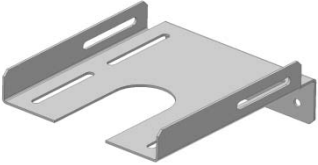
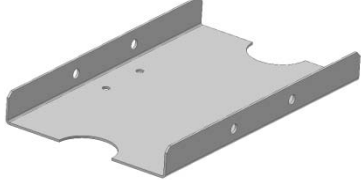
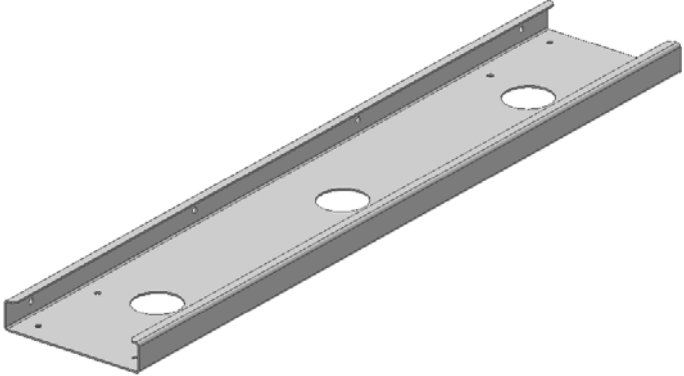
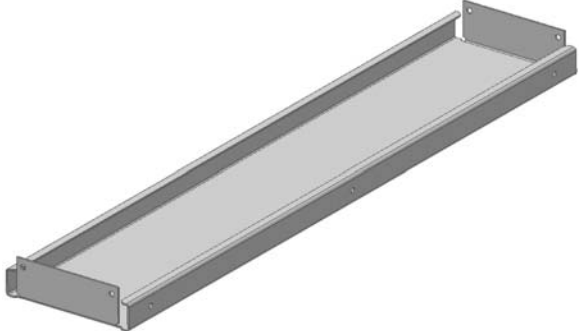
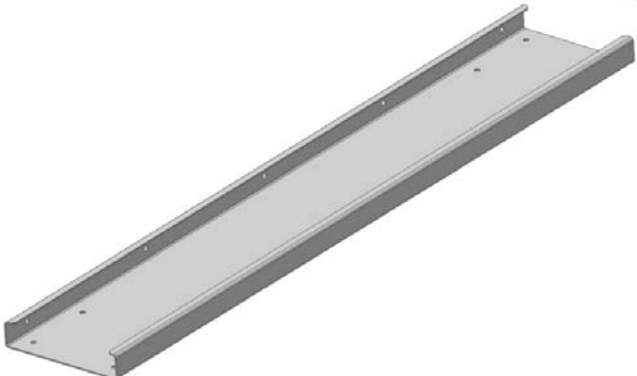
<p><b>A = Corner</b></p>  A 3D perspective view of a corner profile. It is a U-shaped metal piece with two flanges extending at right angles to each other. Each flange has a circular hole near its outer edge.	<p><b>B = Splice</b></p>  A 3D perspective view of a splice profile. It is a flat metal piece with a central semi-circular cutout. It has two flanges extending from the long edges, each with a circular hole.
<p><b>C = Length profile</b></p>  A 3D perspective view of a length profile. It is a long, narrow metal channel with a U-shaped cross-section. It features two circular holes along its length, one on each side.	
<p><b>D = Spacer profile</b></p>  A 3D perspective view of a spacer profile. It is a long, narrow metal channel with a U-shaped cross-section, similar to the length profile but with a different internal profile.	
<p><b>E = Width profile</b></p>  A 3D perspective view of a width profile. It is a long, narrow metal channel with a U-shaped cross-section, similar to the length profile but with a different internal profile.	

### 6.1 Base frame length 720 – 2420 [mm] Unit size 10-40

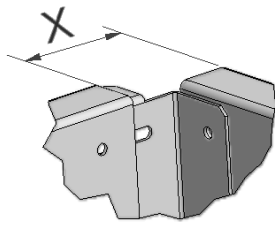

$$X = (\text{Unit length} - C) / 2$$

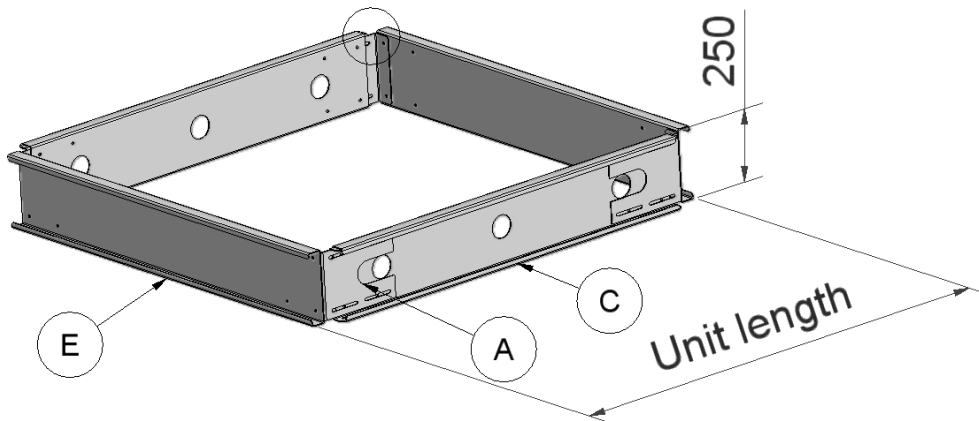

#### Width profile type E

Unit size	Quantity	Length [mm]
DV-10	2	870
DV-15	2	1020
DV-20	2	1170
DV-25	2	1320
DV-30	2	1470
DV-40	2	1620

Frame length [mm]	Quantity	C	A
		Length [mm]	Quantity
700-770	2	520	4
770-920	2	670	4
920-1070	2	820	4
1070-1220	2	970	4
1220-1370	2	1120	4
1370-1520	2	1270	4
1520-1670	2	1420	4
1670-1820	2	1570	4
1820-1970	2	1720	4
1970-2120	2	1870	4
2120-2270	2	2020	4
2270-2420	2	2170	4

## 6.2 Base frame length 2420 – 4590 [mm] Unit size 10-40

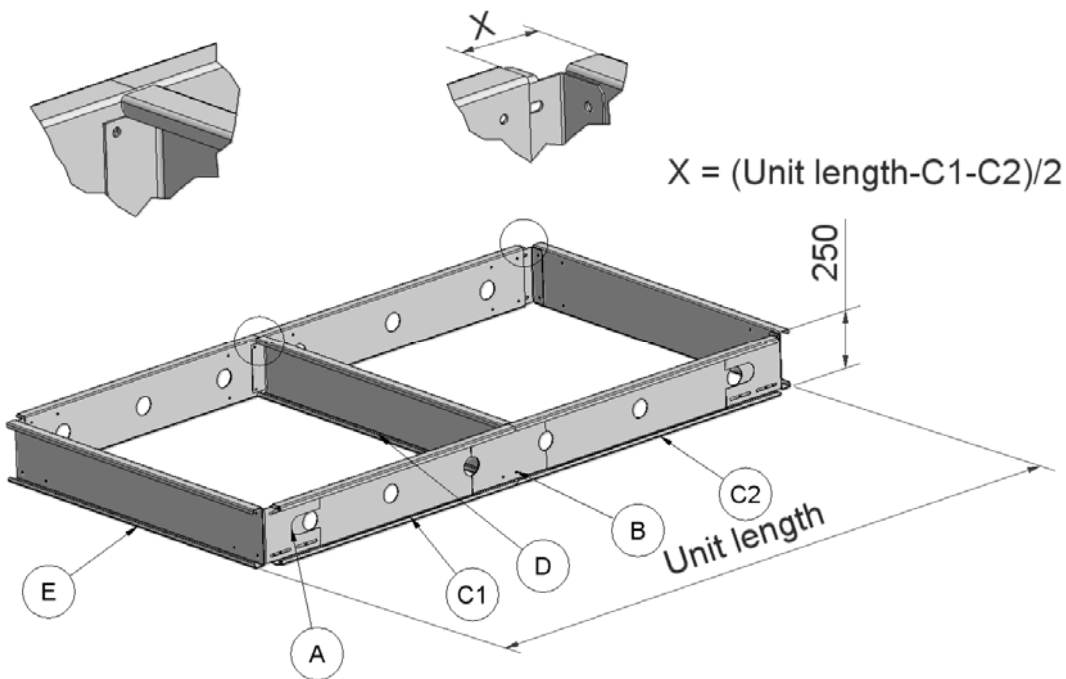

Width profile type E			Spacer profile type D
Unit size	Quantity	Length [mm]	Length [mm]
DV-10	2	870	870
DV-15	2	1020	1020
DV-20	2	1170	1170
DV-25	2	1320	1320
DV-30	2	1470	1470
DV-40	2	1620	1620

Frame length [mm]	C1		C2		A	B	D
	Quantity	Length [mm]	Quantity	Length [mm]	Qty	Qty	Qty
2420-2570	2	1120	2	1200	4	2	1
2570-2640	2	1270	2	1200	4	2	1
2640-2790	2	1270	2	1270	4	2	1
2790-2940	2	1270	2	1420	4	2	1
2940-3090	2	1420	2	1420	4	2	1
3090-3240	2	1420	2	1570	4	2	1
3240-3390	2	1570	2	1570	4	2	1
3390-3540	2	1570	2	1720	4	2	1
3540-3690	2	1720	2	1720	4	2	1
3690-3840	2	1720	2	1870	4	2	1
3840-3990	2	1870	2	1870	4	2	1
3990-4140	2	1870	2	2020	4	2	1
4140-4290	2	2020	2	2020	4	2	1
4290-4440	2	2020	2	2170	4	2	1
4440-4590	2	2170	2	2170	4	2	1

### 6.3 Base frame length 4590 – 6200 [mm] Unit size 10-40

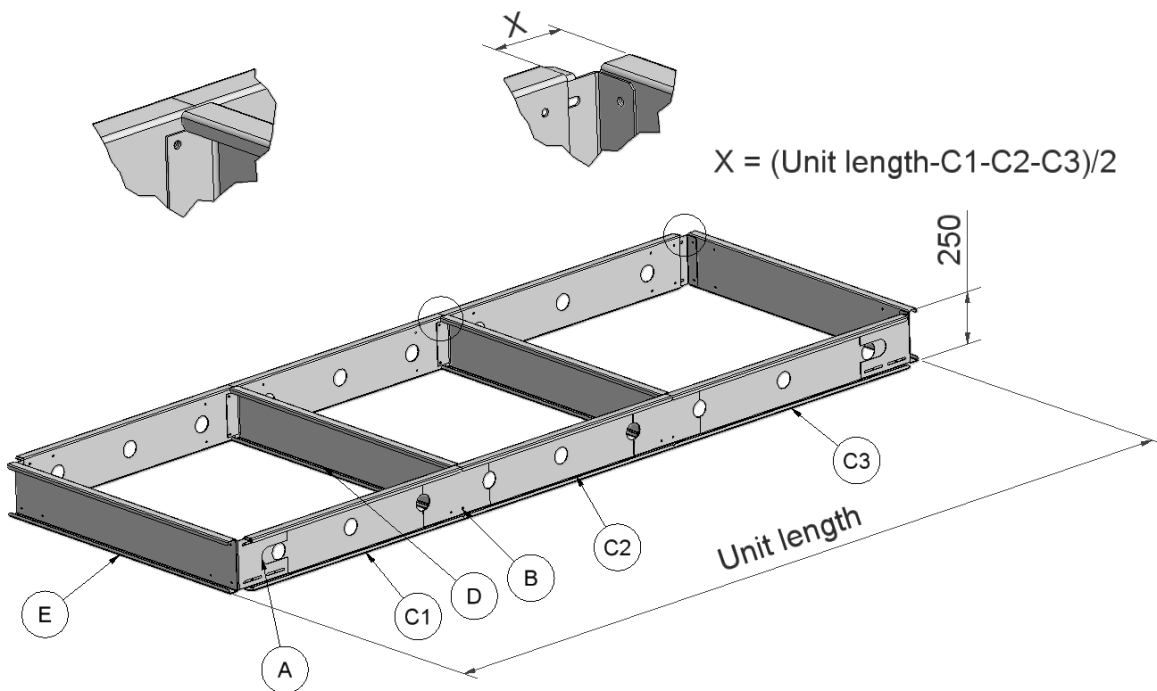

Width profile type E			Spacer profile type D
Unit size	Quantity	Length [mm]	Length [mm]
DV-10	2	870	870
DV-15	2	1020	1020
DV-20	2	1170	1170
DV-25	2	1320	1320
DV-30	2	1470	1470
DV-40	2	1620	1620

		C1		C2		C3		A	B	D
Frame length [mm]	Qty	Length [mm]	Qty	Length [mm]	Qty	Length [mm]	Qty	Qty	Qty	
4590-4740	2	1420	2	1500	2	1570	4	4	2	
4740-4890	2	1570	2	1570	2	1500	4	4	2	
4890-5040	2	1720	2	1500	2	1570	4	4	2	
5040-5110	2	1720	2	1720	2	1500	4	4	2	
5110-5260	2	1720	2	1720	2	1570	4	4	2	
5260-5410	2	1720	2	1720	2	1720	4	4	2	
5410-5560	2	1870	2	1720	2	1720	4	4	2	
5560-5710	2	1870	2	1870	2	1720	4	4	2	
5710-5860	2	1870	2	1870	2	1870	4	4	2	
5860-6010	2	2020	2	1870	2	1870	4	4	2	
6010-6160	2	2020	2	2020	2	1870	4	4	2	
6160-6200	2	2020	2	2020	2	2020	4	4	2	



**Annex 7. Assemble base frames - height 250 mm for units sizes 50-150**

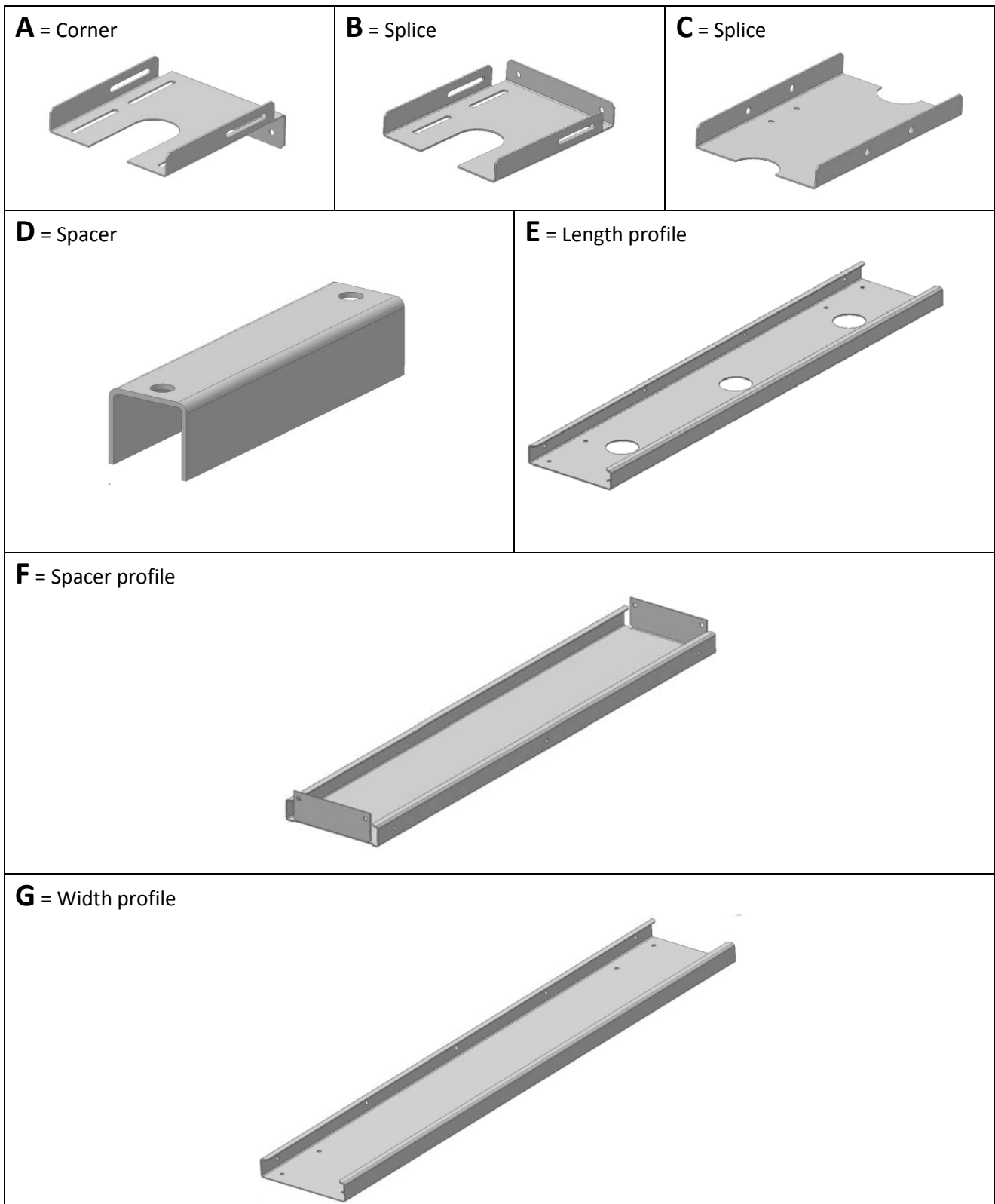

### 7.1 Base frame length 720 – 2420 [mm] Unit size 50-150

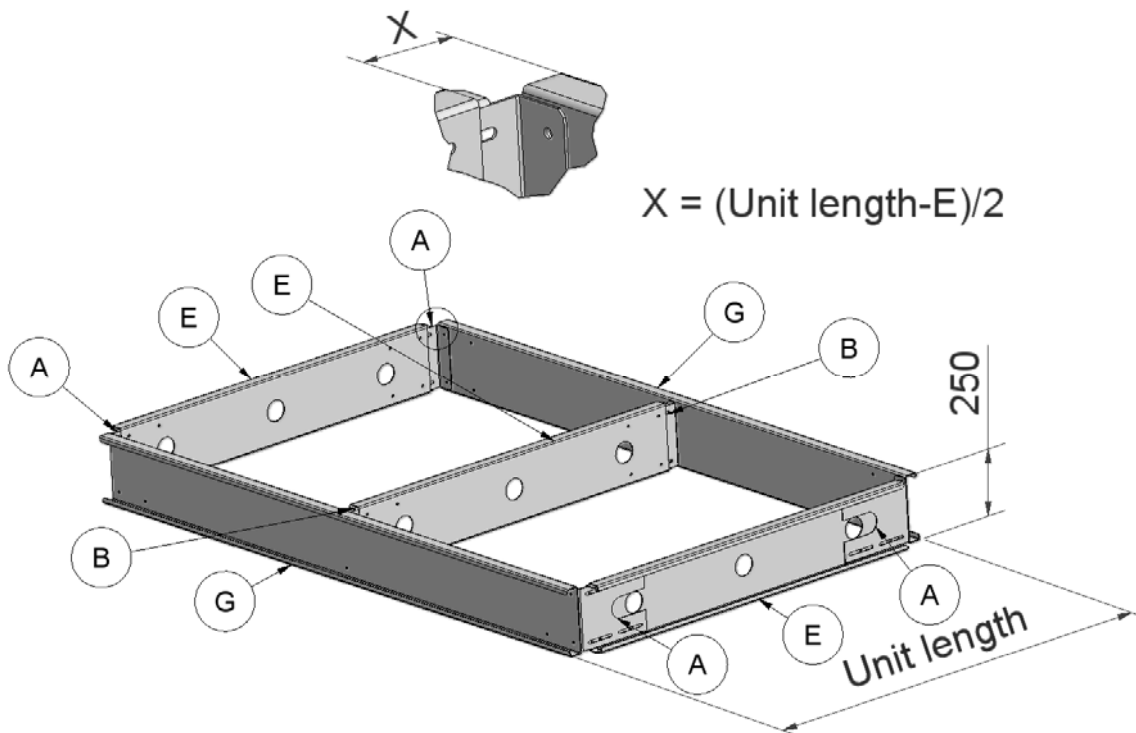

#### Width profile type G

Unit size	Quantity	Length [mm]
DV-50	2	1920
DV-60	2	2070
DV-80	2	2070
DV-100	2	2270
DV-120	2	2490
DV-150	2	2790

Frame length [mm]	Quantity	E		
		Length [mm]	A	B
			Quantity	Quantity
700-770	3	520	4	2
770-920	3	670	4	2
920-1070	3	820	4	2
1070-1220	3	970	4	2
1220-1370	3	1120	4	2
1370-1520	3	1270	4	2
1520-1670	3	1420	4	2
1670-1820	3	1570	4	2
1820-1970	3	1720	4	2
1970-2120	3	1870	4	2
2120-2270	3	2020	4	2
2270-2420	3	2170	4	2

## 7.2 Base frame length 2420 – 4590 [mm] Unit size 50-150

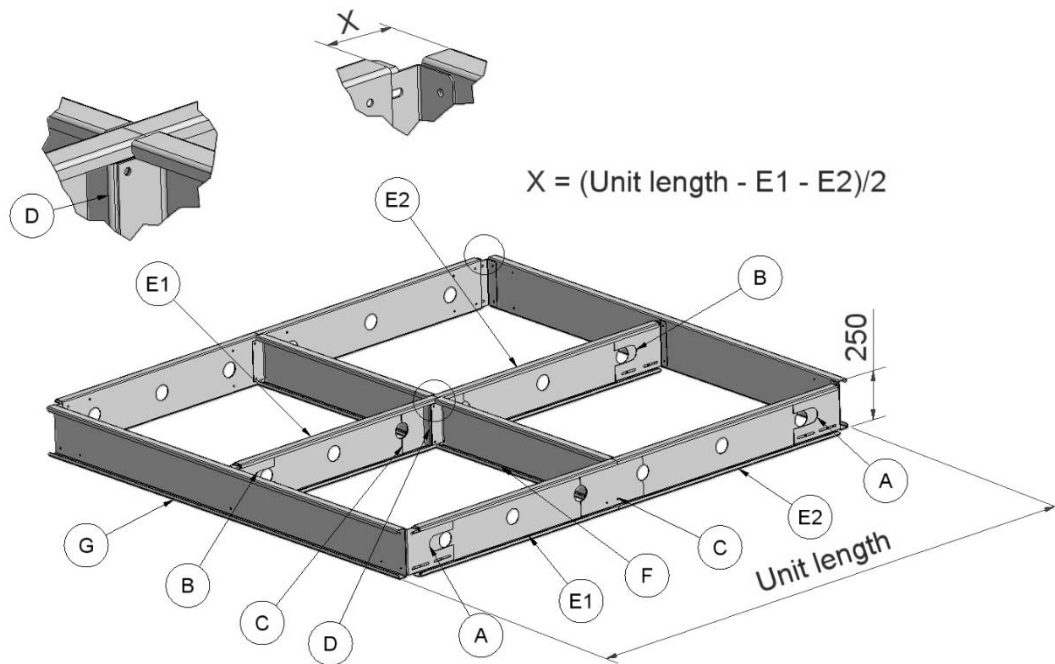

Width profile type G			Spacer profile type F
Unit size	Quantity	Length [mm]	Length [mm]
DV-50	2	1920	935
DV-60	2	2070	1010
DV-80	2	2070	1010
DV-100	2	2270	1110
DV-120	2	2490	1220
DV-150	2	2790	1370

Frame length [mm]	Qty	C1		C2		A	B	C	D	F
		Length [mm]	Qty	Length [mm]	Qty	Qty	Qty	Qty	Qty	
2420-2570	3	1120	3	1200	4	2	3	1	2	
2570-2640	3	1270	3	1200	4	2	3	1	2	
2640-2790	3	1270	3	1270	4	2	3	1	2	
2790-2940	3	1270	3	1420	4	2	3	1	2	
2940-3090	3	1420	3	1420	4	2	3	1	2	
3090-3240	3	1420	3	1570	4	2	3	1	2	
3240-3390	3	1570	3	1570	4	2	3	1	2	
3390-3540	3	1570	3	1720	4	2	3	1	2	
3540-3690	3	1720	3	1720	4	2	3	1	2	
3690-3840	3	1720	3	1870	4	2	3	1	2	
3840-3990	3	1870	3	1870	4	2	3	1	2	
3990-4140	3	1870	3	2020	4	2	3	1	2	
4140-4290	3	2020	3	2020	4	2	3	1	2	
4290-4440	3	2020	3	2170	4	2	3	1	2	
4440-4590	3	2170	3	2170	4	2	3	1	2	

### 7.3 Base frame length 4590 – 6200 [mm] Unit size 50-150

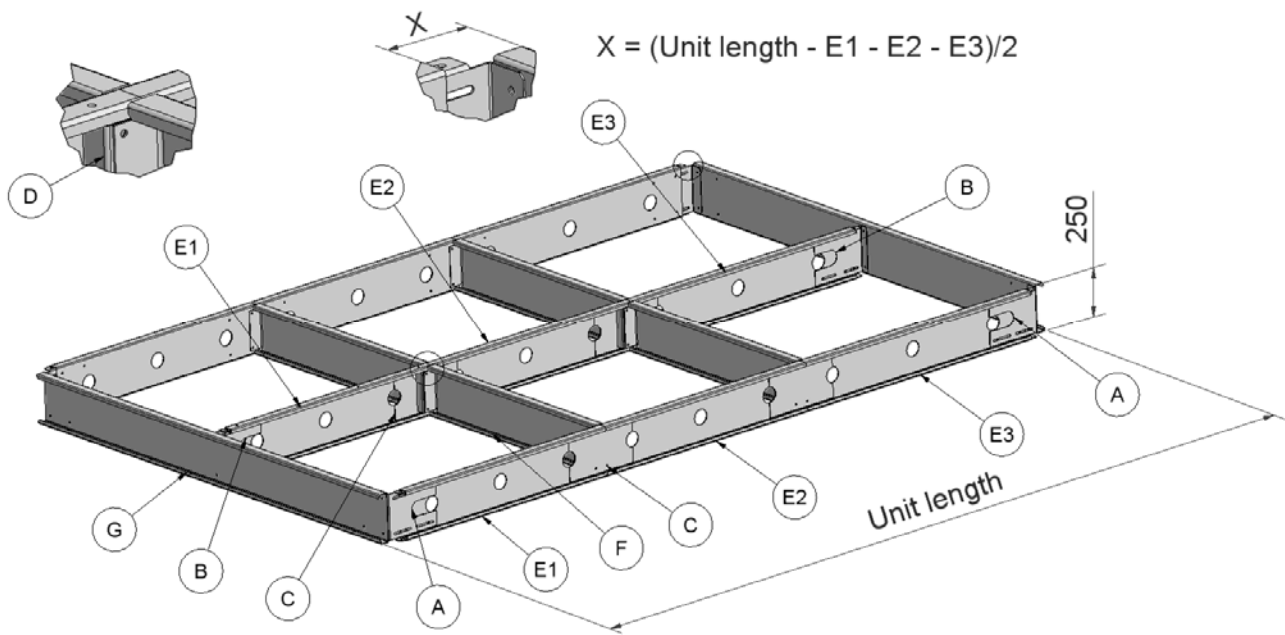

Width profile type G			Spacer profile type F
Unit size	Quantity	Length [mm]	Length [mm]
DV-50	2	1920	935
DV-60	2	2070	1010
DV-80	2	2070	1010
DV-100	2	2270	1110
DV-120	2	2490	1220
DV-150	2	2790	1370

Frame length [mm]	E1		E2		E3		A	B	C	D	F
	Qty	Length [mm]	Qty	Length [mm]	Qty	Length [mm]	Qty	Qty	Qty	Qty	Qty
4590-4740	3	1420	3	1500	3	1570	4	2	6	2	4
4740-4890	3	1570	3	1570	3	1500	4	2	6	2	4
4890-5040	3	1720	3	1500	3	1570	4	2	6	2	4
5040-5110	3	1720	3	1720	3	1500	4	2	6	2	4
5110-5260	3	1720	3	1720	3	1570	4	2	6	2	4
5260-5410	3	1720	3	1720	3	1720	4	2	6	2	4
5410-5560	3	1870	3	1720	3	1720	4	2	6	2	4
5560-5710	3	1870	3	1870	3	1720	4	2	6	2	4
5710-5860	3	1870	3	1870	3	1870	4	2	6	2	4
5860-6010	3	2020	3	1870	3	1870	4	2	6	2	4
6010-6160	3	2020	3	2020	3	1870	4	2	6	2	4
6160-6200	3	2020	3	2020	3	2020	4	2	6	2	4

## Annex 8. Installation of steel roof in the sizes 10-150

### 8.1 Overview

- Mount rails A1, B2, C3, D4, E5 on the unit for support of trapezoidal roof plates (mount also rails Y and Z on units of the size 30 and on units that are larger than size 30 longitudinally at the centre-line of the units).
- Place foam bands – P – on the horizontal rails A1, B2, C3 and D4 for support of roof plates.
- Calculate overhang of the roof at both ends of the unit and mount roof overhang profile – G1 on the first trapezoidal roof plate – F1 before the roof plate is mounted.
- Place and mount roof plates F1, F2, F3 and so on.
- Remember foam bands on the side laps between roof plates to prevent rainwater from passing through.
- Place roof overhang profile – G5 at the other end of the unit before the last roof plate is mounted.
- Mount sides and corners on the roof.
- Apply sealing where plates are joined to ensure water resistance - even in stormy weather.

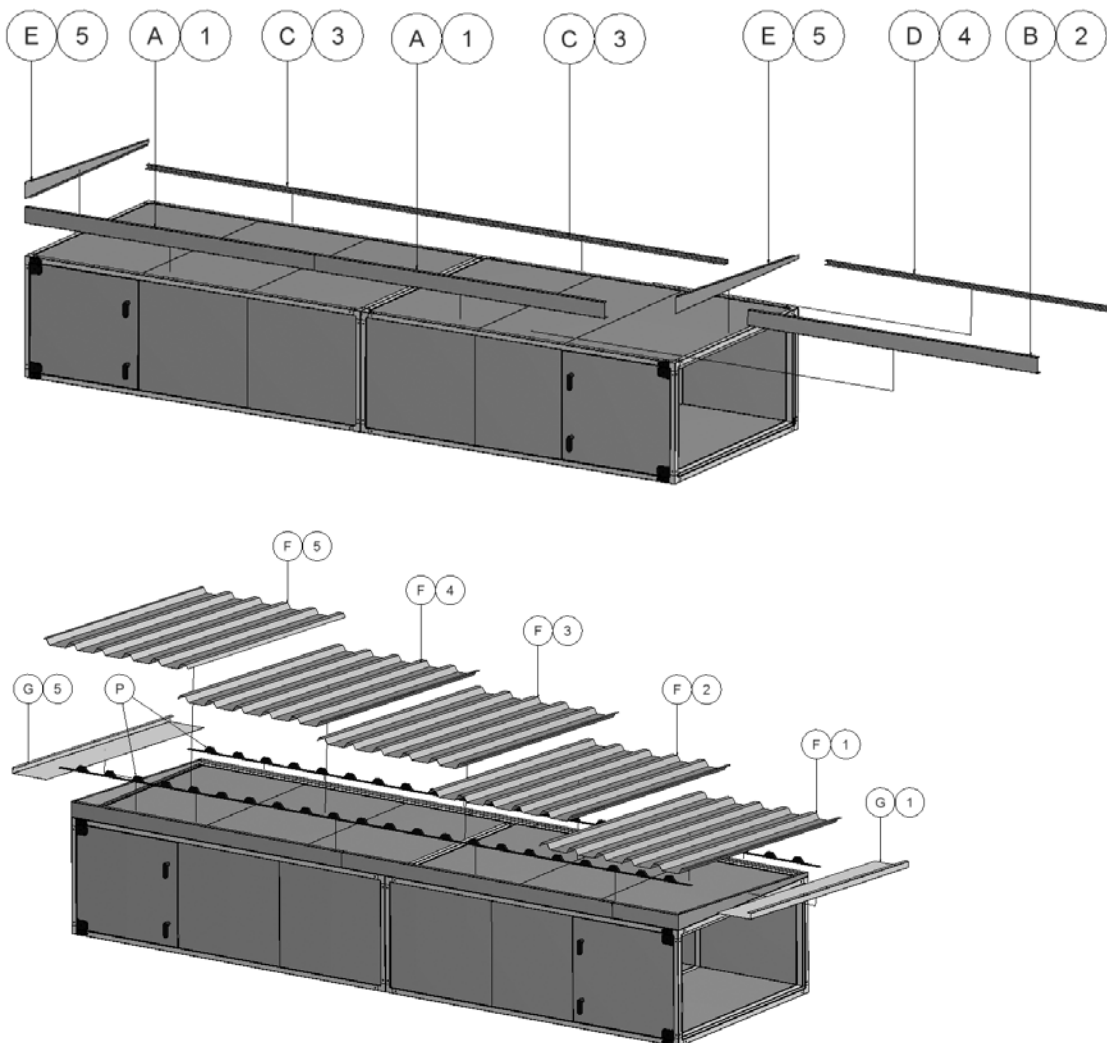

#### 8.1.1 Mount rails. Units of size 10, 15, 20, and 25

Squeeze sealant in sufficient quantity between the underside of the rails A1, B2, C3, D4, E5 and the horizontal top side of the unit before the rails are mounted. This means that the rails are standing on

sealant to achieve the tightest connection between rails and unit to prevent rainwater from passing under the rails and into the unit. Mount the rails A1 and B2 on the front side (the side with the inspection doors) – use the simple self-drilling screws without the sealing washer – see the illustration of the screw below.



**Note:** Rail B2 fits into the rail A1, and this offers the advantage that the rail B2 can be slid inside the rail A1 to adjust the length of rail B2 accurately to the length of the unit. In this way it is not necessary to spend time and effort cutting the rail B2.

Mount the lower rails C3 and D4 on the back side of the unit.

**Note:** Rail D4 fits into the rail C3, and this offers the advantage that the rail D4 can be slid inside the rail C3 to adjust the length of rail D4 accurately to the length of the unit. In this way it is not necessary to spend time and effort on cutting the rail D4.

Mount vertical rail – E5 - with the roof slope at each end of the unit

**It is important to place a screw in each hole** – even though the number of holes for screws seems to be very large, a screw in each hole is necessary as the stress on the roof during stormy weather is extremely high.

### 8.1.2 Mount rails. Units of size 30 and units larger than size 30.

On units of size 30 and on units that are larger than size 30, rails A1, B2, C3, D4, E5 must be mounted on the unit for support of trapezoidal roof plates, but also rails Y and Z must be mounted longitudinally at the centre-line of the units to hold the trapezoidal roof plates.

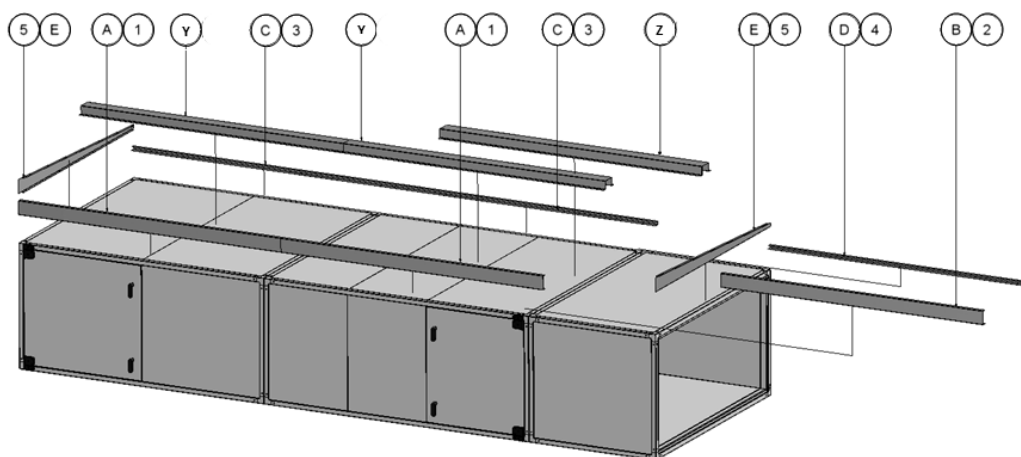

Squeeze sealant in sufficient quantity between the underside of the rails A1, B2, C3, D4, E5 and the horizontal top side of the unit before the rails are mounted. This means that the rails are standing on sealant to achieve the tightest connection between rails and unit to prevent rainwater from passing under the rails and into the unit. Mount the rails A1 and B2 on the front side (the side with the inspection doors) – use the simple self drilling screws without the sealing washer – see the illustration of the screw below.



**Note:** Rail B2 fits into the rail A1, and this offers the advantage that the rail B2 can be slid inside the rail A1 to adjust the length of rail B2 accurately to the length of the unit. In this way it is not necessary to spend time and effort cutting the rail B2.

Mount the lower rails C3 and D4 on the back side of the unit.

**Note:** Rail D4 fits into the rail C3, and this offers the advantage that the rail D4 can be slid inside the rail C3 to adjust the length of rail D4 accurately to the length of the unit. In this way it is not necessary to spend time and effort cutting the rail D4.

Mount vertical rail – E5 - with the roof slope at each end of the unit.

Mount the rails Y and Z on the unit with the centre-line of the rails exactly over the centre-line of the unit. It is longitudinal on the middle of the units to hold the trapezoidal roof plates.

**Notice,** that rail Z fits over the lower rail Y, and this offers the advantage that the rail Z can be slid on the rail Y to adjust the length of rail Z accurately to the length of the unit. In this way it is not necessary to spend time and effort on cutting the rail Z.

**It is important to place a screw in each hole** – even though the number of holes for screws seems to be very large, a screw in each hole is necessary as the stress on the roof during stormy weather is extremely high.

### **8.1.3 Roof overhang along the long sides of the unit**

The roof plates are longer than the width of the unit to ensure sufficient overhang along the sides of the unit.

The overhang is 100 mm along each side of the smallest unit – size 10.

The overhang is 150 mm along each side of the units – size 15, 20, 25.

The overhang is 175 mm along each side of the biggest units – including size 30.

### **8.1.4 Calculation of the overhang at the ends of the unit. Mount overhang profile – G1.**

The roof must be between 200 and 400 mm longer than the length of the unit to secure a roof overhang between 100 mm and 200 mm at the each of the 2 ends of the unit, and the length of this overhang must be calculated before the first roof plate is mounted.

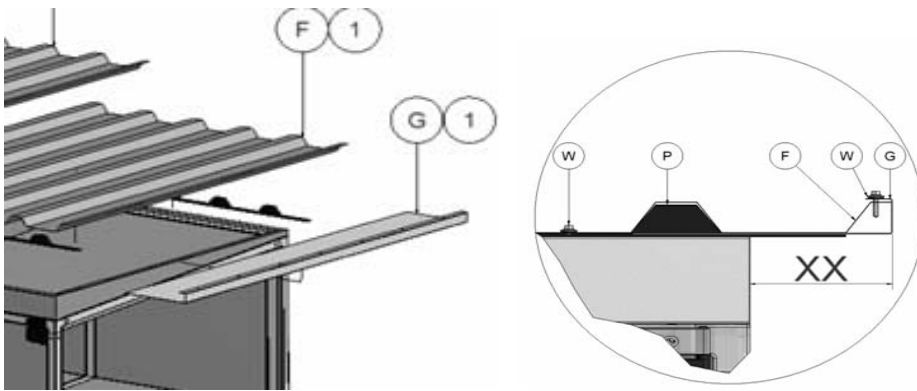

The unit is delivered with 2 similar overhang profiles - G1 and G5 - one for each end of the roof. Mount one of the 2 roof overhang profiles – G on a trapezoidal roof plate. Use the self drilling, painted screws with sealing washers - W - see the illustration.

**Note:** Foam bands - P – are necessary between the overhang profile G1 and the roof plate F1. See the illustration.



Self-drilling, painted screws supplied with sealing washer for the mounting of the trapezoidal plate to the roof overhang profile.

The total cover width of the trapezoidal roof plates always changes with the pitch of 205 mm between the trapezoidal ribs, making up a total length of the complete roof of - for example 2100 mm, 2305 mm, 2510 mm and so on. We call this length of the total roof for RL and we call the total length of the complete unit for AL. The trapezoidal roof must always be longer than the unit, to obtain a reasonable overhang called – XX - of the roof at both ends.

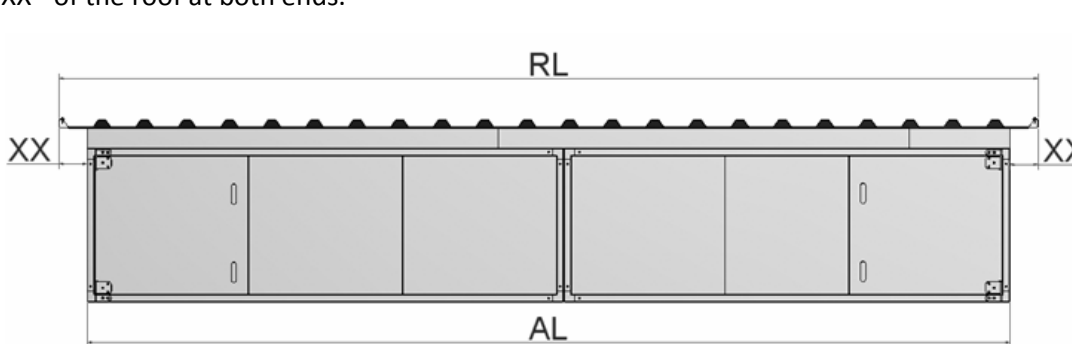

In the table below you will find 40 different lengths of roofs (always changing with the 205 mm) and the lengths of units that are ideal for each of the 40 alternative roof lengths.

Measure the total length – AL of the unit – for example 5000 mm between the 4982 and 5182 mm mentioned in the table below.



AHU length AL	Roof length RL
1670 – 1870	2100
1877 – 2077	2305
2084 – 2284	2510
2291 – 2491	2715
2498 – 2698	2920
2705 – 2905	3125
2912 – 3112	3330
3119 – 3319	3535
3326 – 3526	3740
3533 – 3733	3945
3740 – 3940	4150
3947 – 4147	4355
4154 – 4354	4560
4361 - 4561	4765

AHU length AL	Roof length RL
4568 – 4768	4970
4775 – 4975	5175
4982 – 5182	5380
5189 – 5389	5585
5396 – 5596	5790
5603 – 5803	5995
5810 – 6010	6200
6017 – 6217	6405
6224 – 6424	6610
6431 – 6631	6815
6638 – 6838	7020
6845 – 7045	7225
7052 – 7252	7430
7259 - 7459	7635

AHU length AL	Roof length RL
7466 – 7666	7840
7673 – 7873	8045
7880 – 8080	8250
8087 – 8287	8455
8294 – 8494	8660
8501 – 8701	8865
8708 – 8908	9070
8915 – 9115	9275
9122 – 9322	9480
9329 – 9529	9685
9536 – 9736	9890
9743 – 9943	10095

The mentioned length of roof – RL - for this length of unit is 5380 mm (the delivered trapezoidal plates can be combined to this length - RL = 5380 mm). 5380 mm minus 5000 mm is 380 mm overhang for both ends, and  $380/2$  mm = 190 mm is the overhang for each end. Place the trapezoidal roof plate F1 with the roof overhang profile G1 on rail E with an overhang of 190 mm.

### 8.1.5 Foam bands between rails and roof plates – mount roof plates.

Place foam bands P between profiles A1, B2, C3, D4 and roof plates.

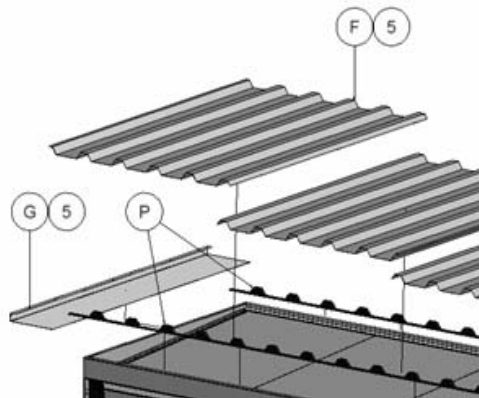

The trapezoidal roof plates are mounted with the self-drilling, painted screws supplied with sealing washer.

### 8.1.6 Foam bands between roof plates

Mount the self-adhesive foam band – O - on the underlapping rib for water resistant and effective sealing due to the small slope of the roof.

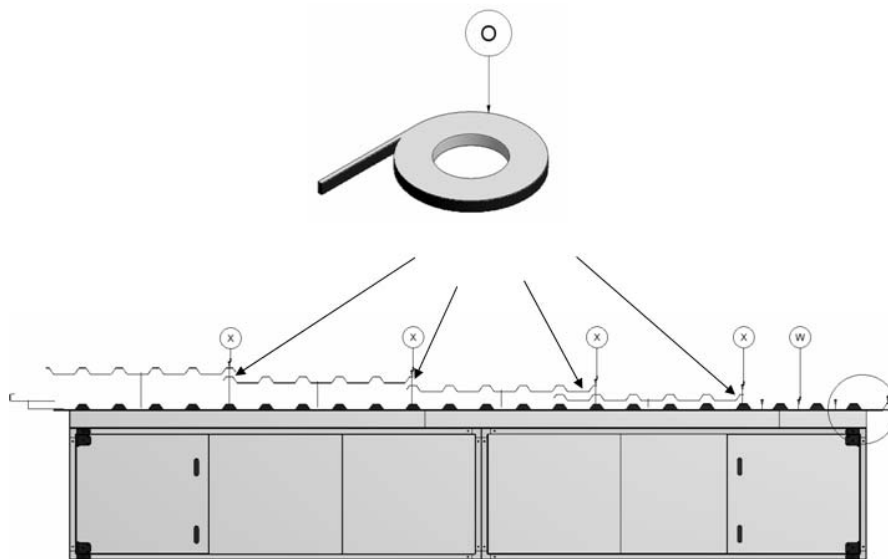

### 8.1.7 Mount roof plates – some of them are overlapping by 2 ribs

The width of each plate is always 1025 mm and some of the plates have to overlap by 2 ribs to achieve the optimal total length of the whole roof — see the illustration above.

### 8.1.8 Mount overhang profile – G5 on the other end of the unit.

When the last trapezoidal plate (in this example F5) has been placed on the unit, the second roof overhang profile G5 must be pushed under the trapezoidal roof plate and mounted with the self-drilling, painted screw with sealing washer. Mounting must be similar to the mounting of roof overhang profile under the trapezoidal roof plate at the other end of the unit.

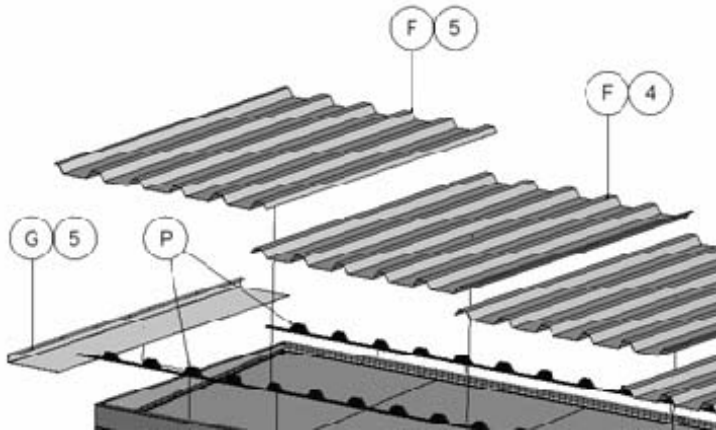

### 8.1.9 Mount side profiles and corners along the edges of the roof to protect persons

Profiles N and O with the rectangular holes are for the long and lower side of the roof because rain can escape through the holes. Mount the profiles type N first and the profile O last because the profile O goes over the profile N. Mounted in this order, the profile O can match the end of the roof and the surplus length of the profile O will just cover part of the previous profile N. Mount the profiles L and M along the long and higher front side of the roof. Mount the 4 protection corners.

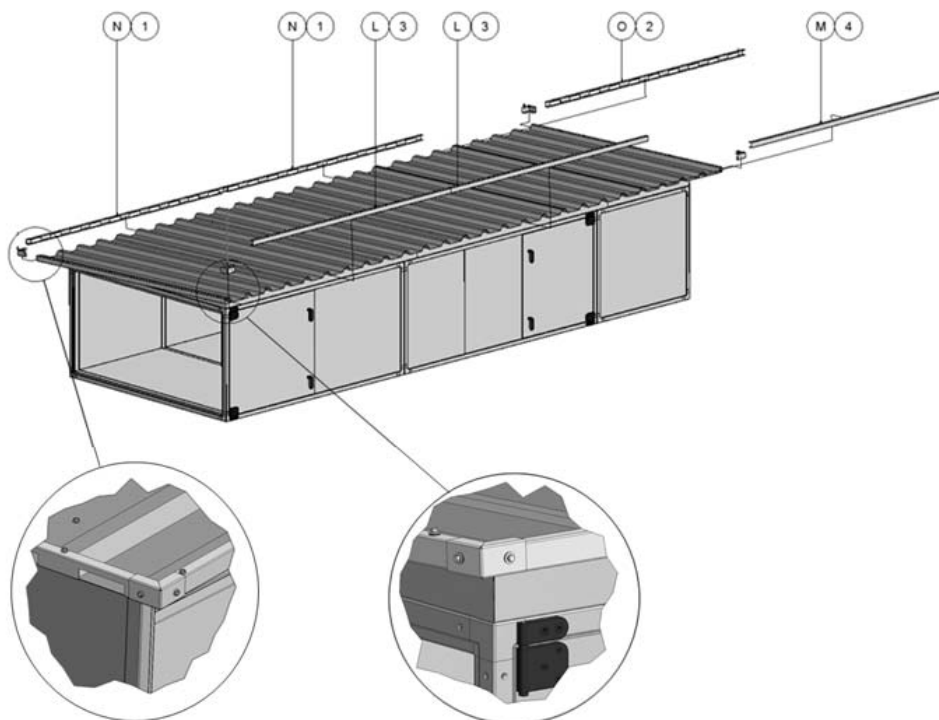

### 8.1.10 Apply sealing on plate joints to ensure water resistance.

Finish installation of the steel roof by sealing all plate joints with silicone to prevent rainwater from passing into the unit. See examples below of joints to be sealed.

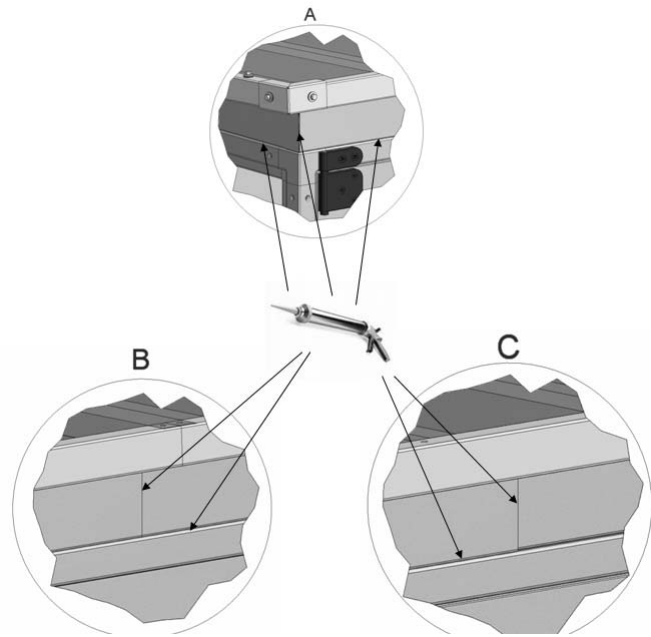

## Annex 9. Speed control for rotor and assembly of divided rotor

### 9.1 Speed control

The cabinet with the speed control system for the rotor is installed behind the inspection door in the rotor section.

The cabinet contains the speed controller with all components, terminal blocks, LED displaying the operation mode, the dual position DIP switch with 8 sliding levers for programming the rotor motor signal and a button for the activation of the test mode.

Through the different combinations of the 8 sliding levers of this dual position DIP switch, the correct signal is available for the 3 different motors used for the 14 sizes of air handling units. The sliding levers are set and the function is checked at the factory. The positions of the levers appear from the tables below.

#### 9.1.1 Selection of correct signal via the 8 DIP switch levers



The 8 DIP switch levers

Position	Function	Code
Up	Active = ON	1
Down	Deactivated = OFF	0

The factory sets the positions of the 8 DIP switch levers for the maximum of 12 revolutions per minute for standard temperature exchangers and for hygroscopic exchangers. The position of each DIP switch lever is shown below.

Rotor 12 rpm		Condensation/temperature (ST), Sorption Hybrid (SH)								Diameter of pulley for rotors from Hoval	Motor type
DV	Position of DIP switches										
	1	2	3	4	5	6	7	8			
10	0	0	0	0	0	0	0	0	0	50	90TYD-S214-M
15	0	0	0	0	0	0	0	0	0	50	
20	1	0	0	0	0	0	0	0	0	50	
25	0	0	0	0	0	0	0	0	0	65	
30	1	0	0	0	0	0	0	0	0	65	
40	1	0	0	0	0	0	0	0	0	65	
50	0	1	0	0	0	0	0	0	0	85	120TYD-S214-M
60	0	1	0	0	0	0	0	0	0	95	
80	0	1	0	0	0	0	0	0	0	106	
100	0	1	0	0	0	0	0	0	0	106	
120	1	1	0	0	0	0	0	0	0	106	
150	1	1	0	0	0	0	0	0	0	106	
190	1	0	1	0	0	0	0	0	0	132	120TYD-S214-L
240	1	0	1	0	0	0	0	0	0	140	

The factory sets the positions of the 8 DIP switch levers for the maximum of 20 revolutions per minute for sorption exchangers. The position of each DIP switch lever is shown below.

Rotor 20 rpm		Sorption (HM) rotors from Hoval								Diameter of pulley for rotors from Hoval	Motor type
DV	Position of DIP switches										
	1	2	3	4	5	6	7	8			
10	1	0	0	0	0	0	0	0	0	65	90TYD-S214-M
15	1	0	0	0	0	0	0	0	0	65	
20	1	0	0	0	0	0	0	0	0	98	
25	1	0	0	0	0	0	0	0	0	98	
30	0	1	0	0	0	0	0	0	0	112	120TYD-S214-M
40	0	1	0	0	0	0	0	0	0	118	
50	1	1	0	0	0	0	0	0	0	118	
60	1	1	0	0	0	0	0	0	0	132	
80	0	0	1	0	0	0	0	0	0	150	120TYD-S214-L
100	1	0	1	0	0	0	0	0	0	150	
120	1	0	1	0	0	0	0	0	0	160	
150	0	1	1	0	0	0	0	0	0	150	
190	0	1	1	0	0	0	0	0	0	180	
240	0	1	1	0	0	0	0	0	0	180	

### 9.1.2 Indication of operation mode via red and green LED as well as test of motor

The LED is in the cover of the cabinet.

LED indication	Value
No indication	Power off
Green	Ordinary operation
Green – flashes	Ready for operation
Constant green and a short red flash	Rotor guard is activated for the short red flash by one bolt on the rotor. By counting the number of red flashes during one minute, you hereby check the number of revolutions per minute.
Red flashes in series	See explanation below
Red	Alarm due to internal error. Is still operating for some minutes

Number of red flashes in series	Value
1	Over current
2	Over voltage
3	Under voltage
4	Failure in the controller

**Restart of rotor:**

- Switch off power and switch on power again  
or
- Press the test button inside the cabinet

**Test of motor by checking the resistance in all 3 windings**

Motor sizes	Ohm
90TYD-S214-M	40Ω
120TYD-S214-M	18Ω
120TYD-S214-L	10Ω

**Setting of constant speed:**

- Set DIP switch 4 in position – ON, and the revolutions are controlled by the adjustable potentiometer on the board.

**Test:**

- Set DIP switch 4 in position – ON
- Press the test button, and the revolutions are controlled by the adjustable potentiometer on the board.

9.1.3 Information about connection of cables to terminals on the control board.

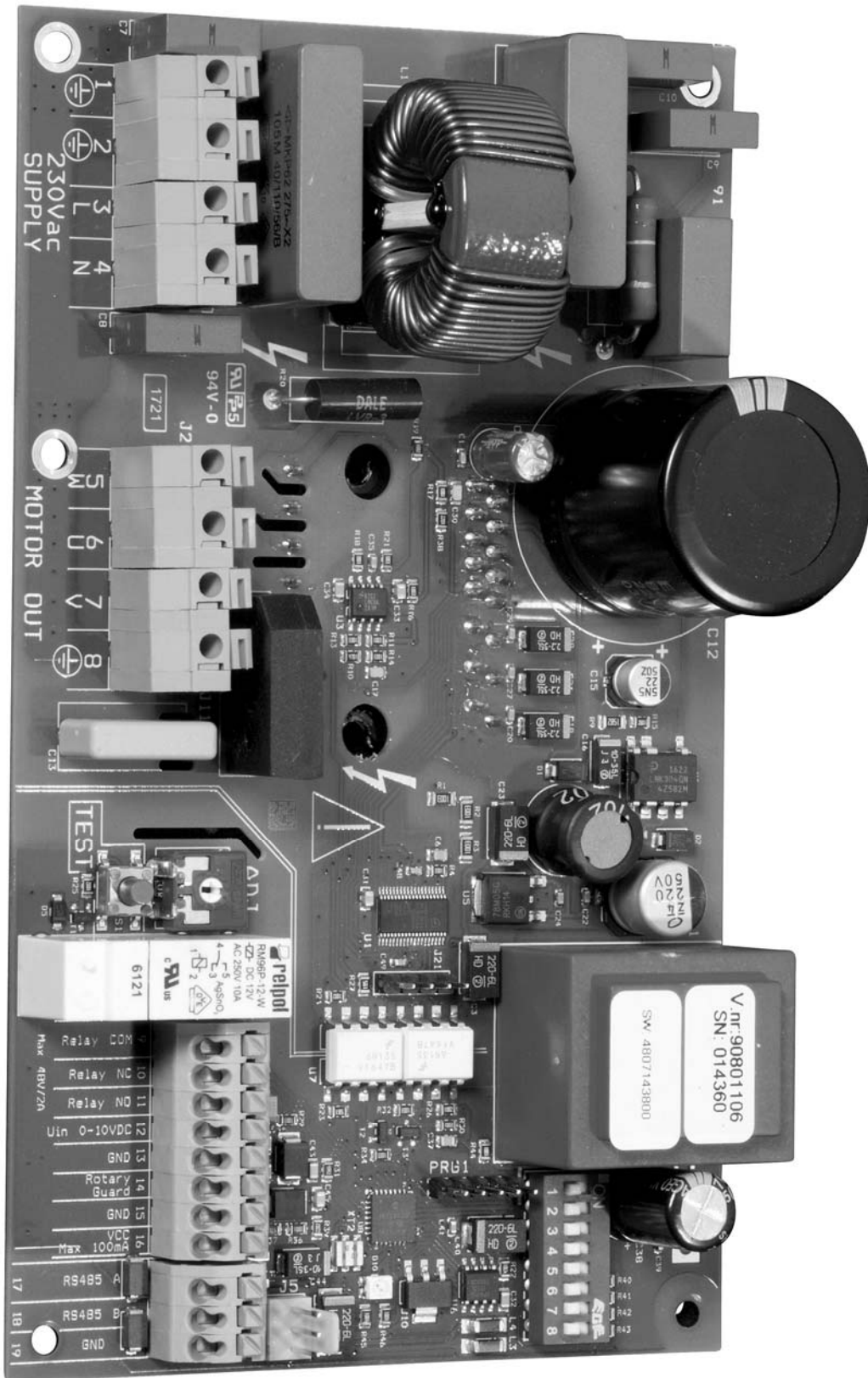



Connection of cables to the terminals on the board		
Terminal	Connection	
1	Earth - supply	
2	Earth - supply	
3	Fase – supply	
4	Neutral – supply	
5	Rotor turns upwards seen from inspection side.	Rotor turn downwards seen from inspection side.
6	Terminal 5 = wire 1 Terminal 6 = wire 2	Terminal 5 = wire 2 Terminal 6 = wire 1
7	Terminal 7 = wire 3	Terminal 7 = wire 3
8	Earth for rotor motor	
Test	Set DIP switch 4 in position – ON – and press the button for test. The signal is controlled by the potentiometer at constant speed <b><u>and not by any signal from the control system.</u></b>	
Adjust	Is activated by setting DIP switch 4 at OFF and DIP switch 5 at ON. Hereby the maximum revolutions can be adjusted between 50 and 100 % by the potentiometer. Usually the factory setting is OK, but with this potentiometer the maximum revolutions can be reduced or increased.	
9	Alarm signal – COM (common)	
10	Alarm signal – Relay is normally closed (this is used by the control system from Systemair)	
11	Alarm signal – Relay is normally open (this is <b><u>not</u></b> used by the control system from Systemair)	
12	Control signal input is 0 - 10 volt DC	
13	Control signal input – ground	
14	Rotor guard – (black cable from rotor guard from Systemair)	
15	Rotor guard – (blue cable from rotor guard from Systemair)	
16	Rotor guard – (brown cable from rotor guard from Systemair)	
17	For BUS signal – RS485 – A (green wire from Systemair control system)	
18	For BUS signal – RS485 – B (yellow wire from Systemair control system)	
19	For BUS signal – ground (white wire from Systemair control system)	

## 9.2 Assemble the Systemair casing for DV60, DV80, DV100, DV120 og DV150

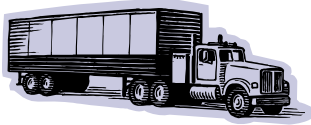
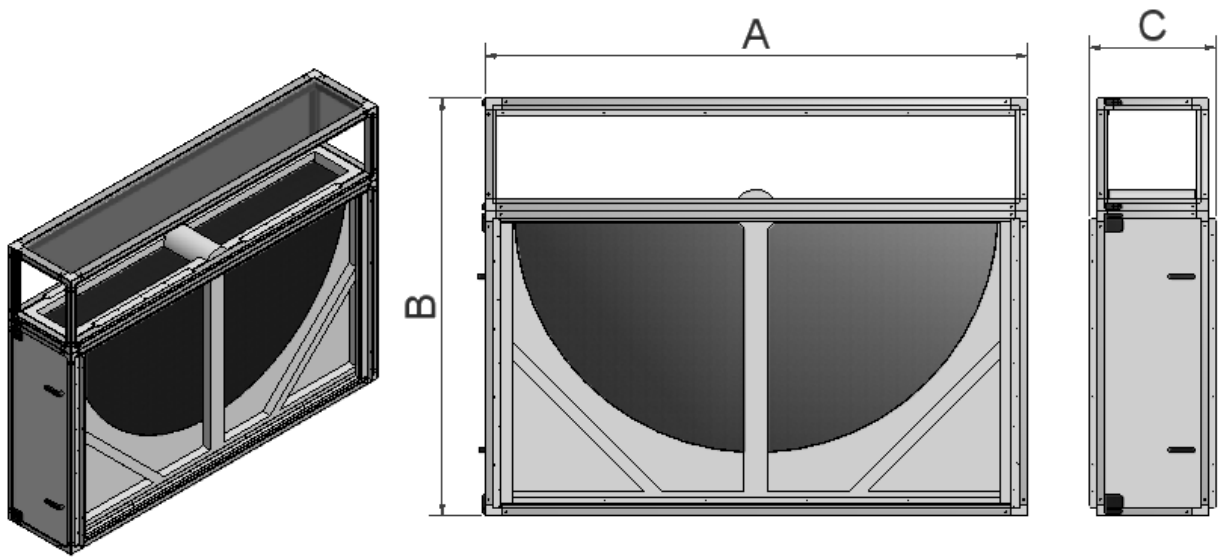

Size	A	B	C
DV 60	2170	1640	520
DV 80	2320	1790	588
DV 100	2520	1940	588
DV 120	2890	2090	558
DV 150	3040	2240	558



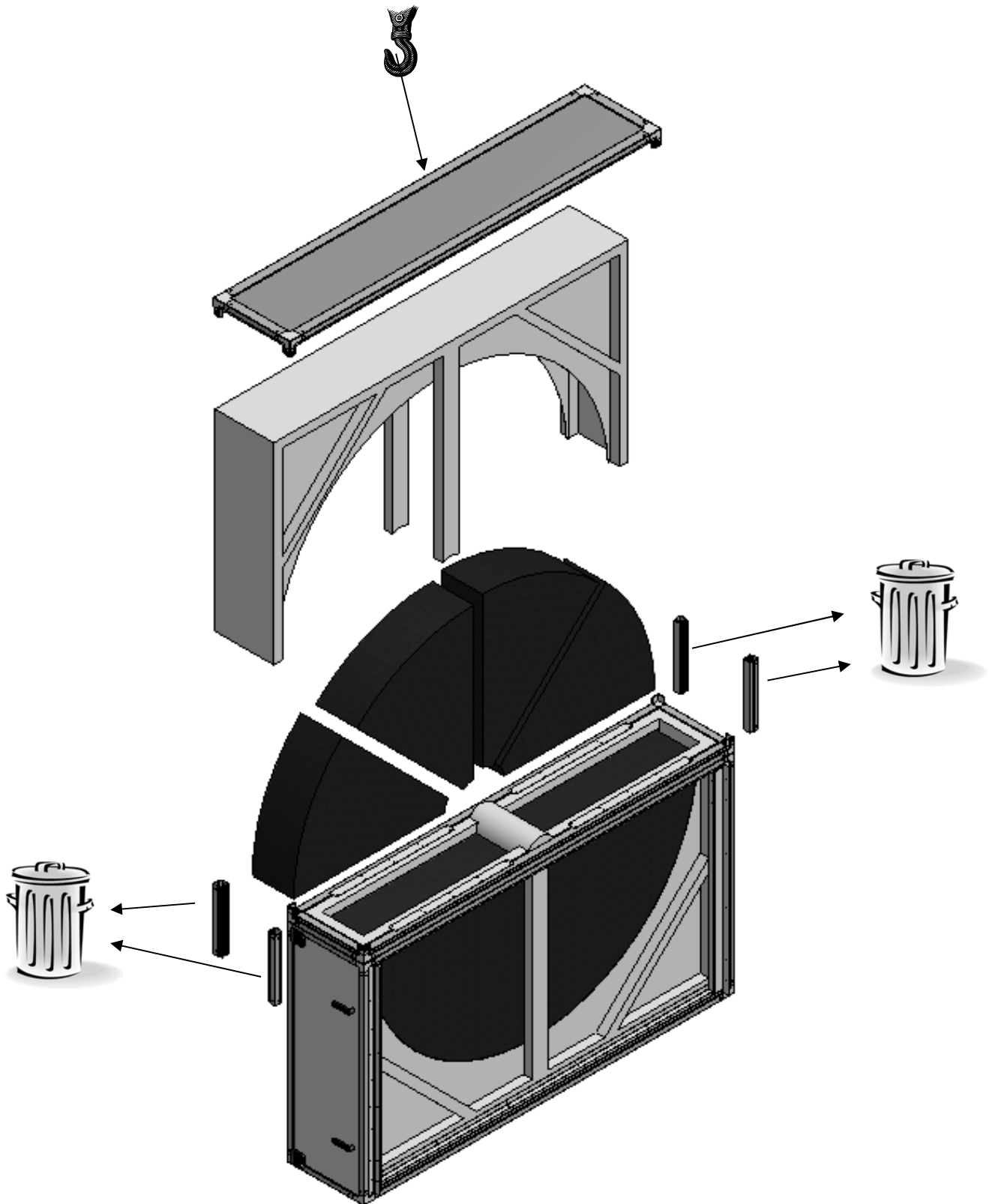

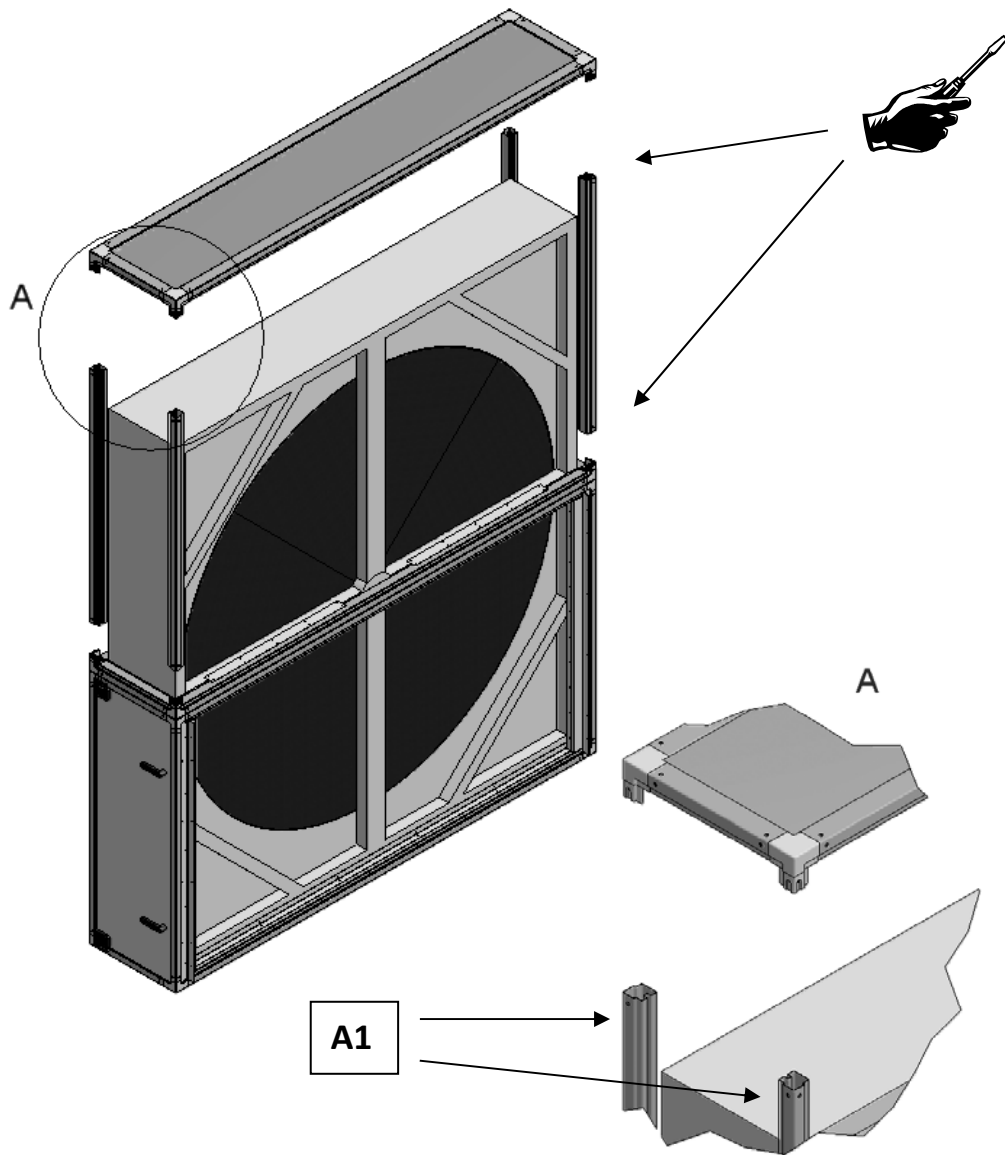

A1		
Size	Quantity	Length (mm)
DV 60	4	1014
DV 80	4	1164
DV 100	4	1314
DV 120	4	1464
DV 150	4	1614

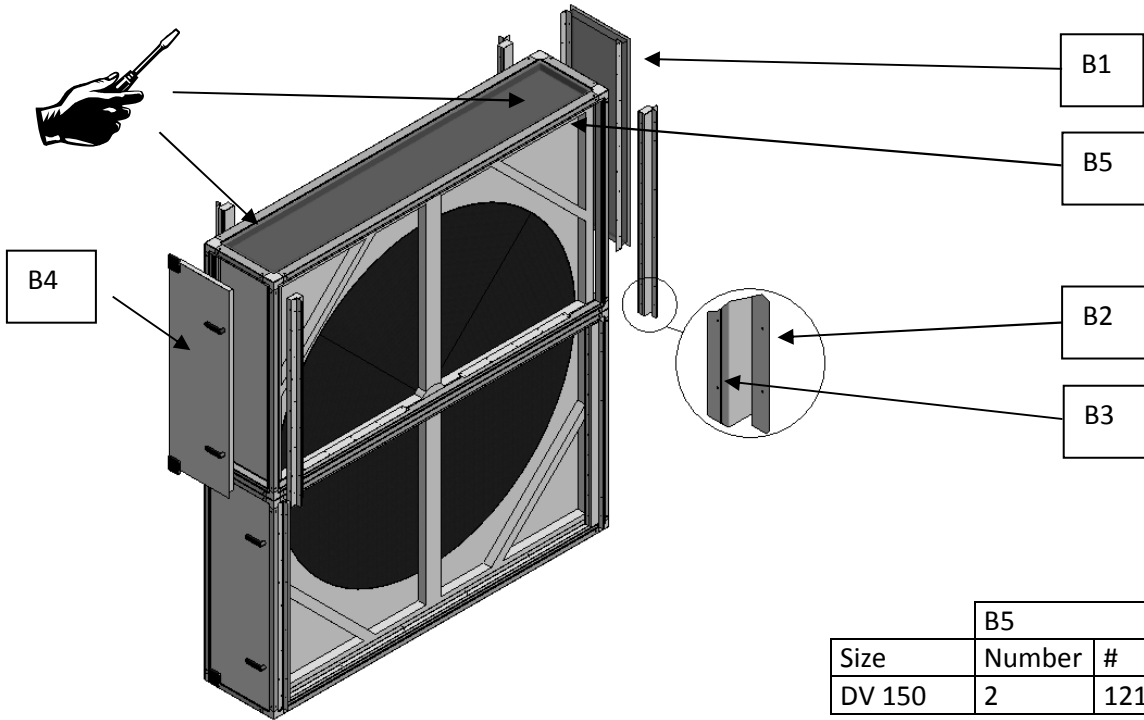

B5		
Size	Number	#
DV 150	2	12100510

Size	B1		B2		B3		B4	
	Quantity	#	Quantity	#	Quantity	#	Quantity	#
DV 60	1	10122310	-	-	-	-	1	10722310
DV 80	1	10122610	4	11200400	4	21000200	1	10722610
DV 100	1	10122710	4	11200410	4	21000210	1	10722710
DV 120	1	10122810	4	12100410	4	21000230	1	10722810
DV 150	1	10122910	4	11200420	4	21000220	1	10722910

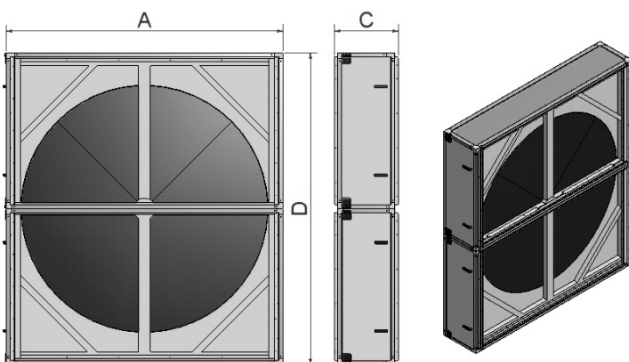

Size	A	C	D
DV 60	2170	520	2240
DV 80	2320	588	2540
DV 100	2520	588	2840
DV 120	2890	558	3140
DV 150	3040	558	3440

### 9.3 Assemble divided rotor from Hoval Enventus for DV 60, DV 80 and DV 100

#### 9.3.1 Tools and aids

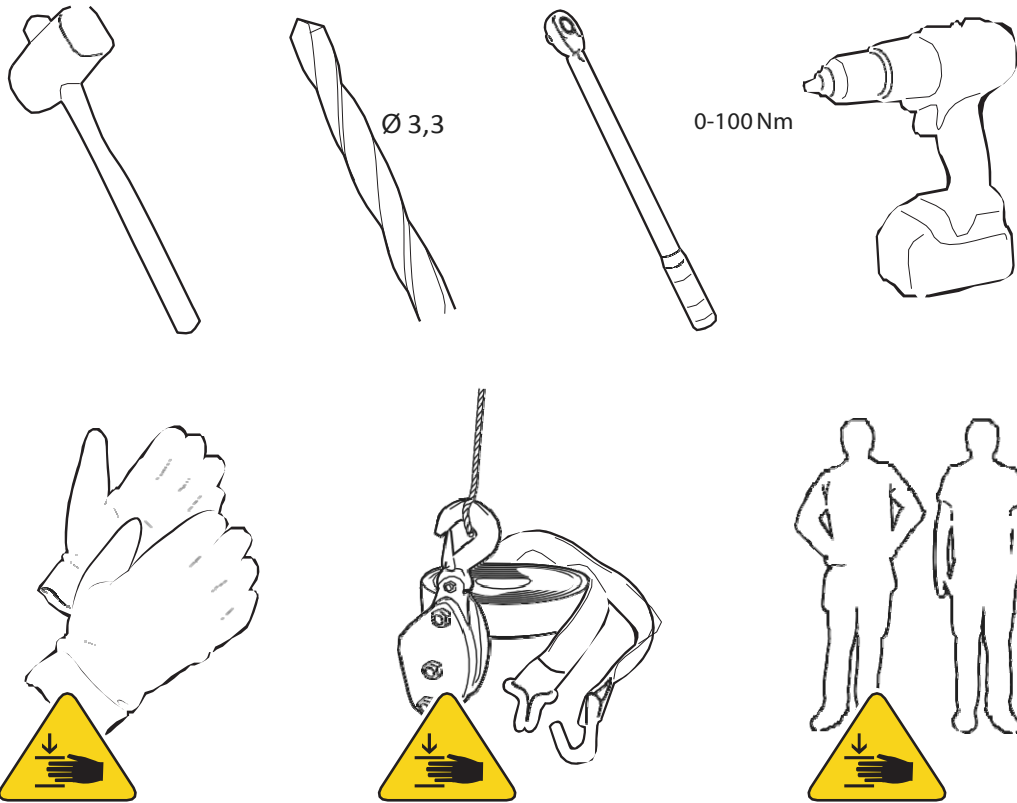

### 9.3.2 Lifting instruction



#### **WARNING! RISK OF CRUSHING!**



To ensure that the lifting of the heat exchanger takes place in a safe manner, and to avoid personal injury and damage to the heat exchanger, we refer to the following instructions. The Hoval Enventus product warranty applies only if the following instructions are followed.

CSD 290 mm

---

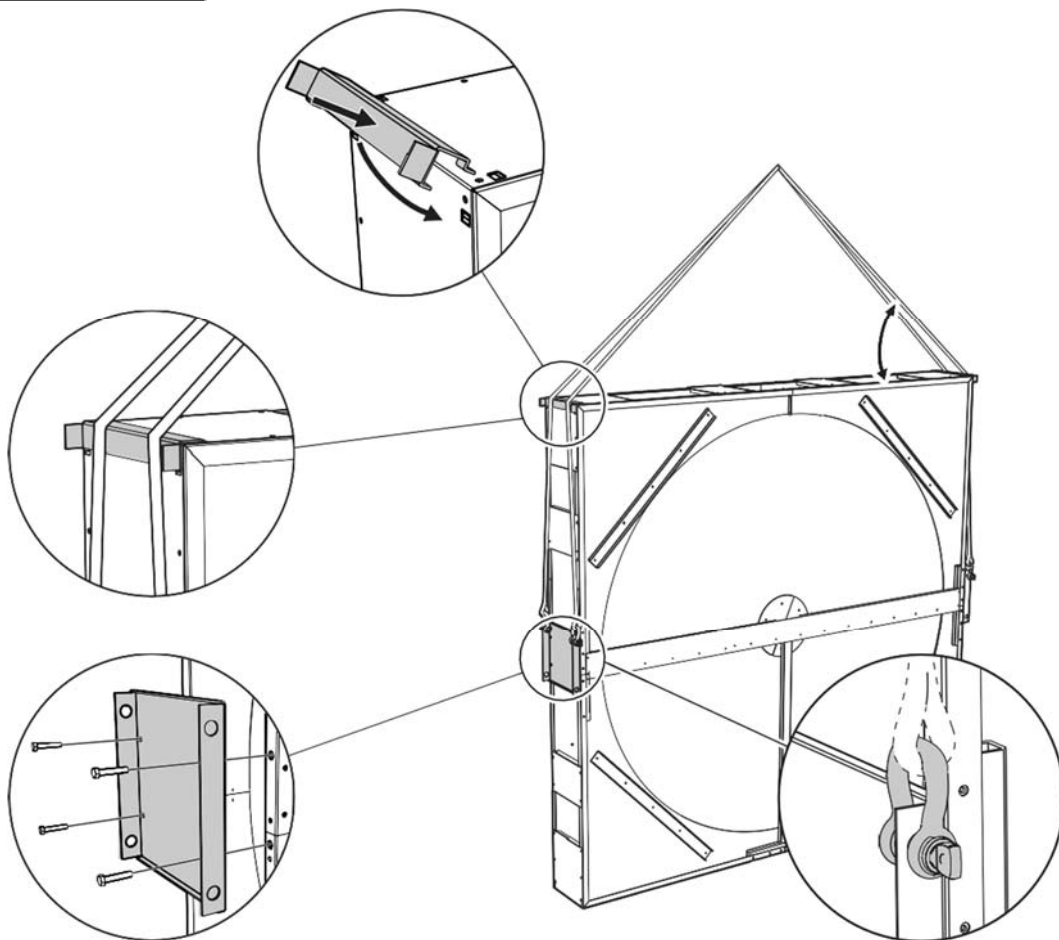

### 9.3.3 Installation



During installation, make sure that the exchanger stands flat so that the rotor is not “at an angle” in the casing.

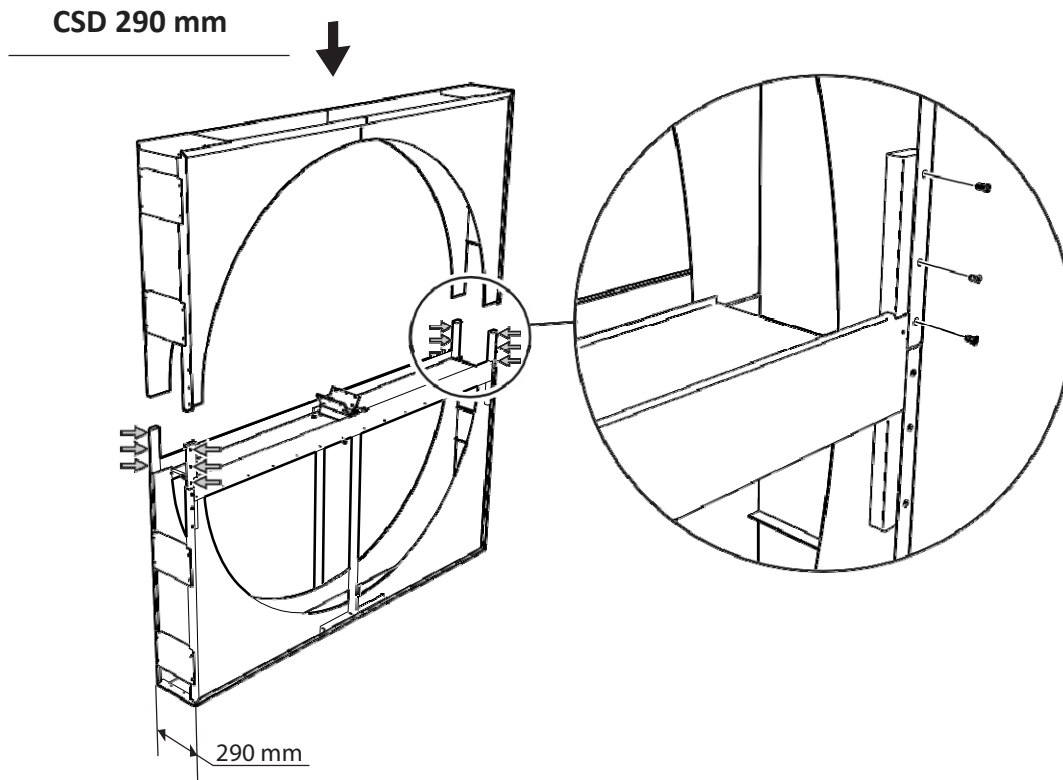

### 9.3.4 Installation of radial walls

Uncontrolled movement of radial walls may cause serious injury. Secure the radial walls carefully while working. Boards can be used to secure them.

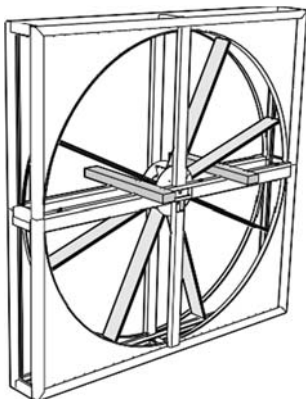



### 9.3.5 Measurement.

The hub with radial walls must be aligned both vertically and horizontally with the casing. If measurement indicates that there are discrepancies, the radial walls, and possibly also the hub, will need to be adjusted.

- Start measuring at the upper radial wall.
- Measure the distances **A** and **B** between the radial walls and the casing at points **1**, **2**, **3** and **4**.
- Measure similar points on the next radial wall.
- Check that values **A** and **B** are the same for both radial walls at all points and that these values match approved tolerances.

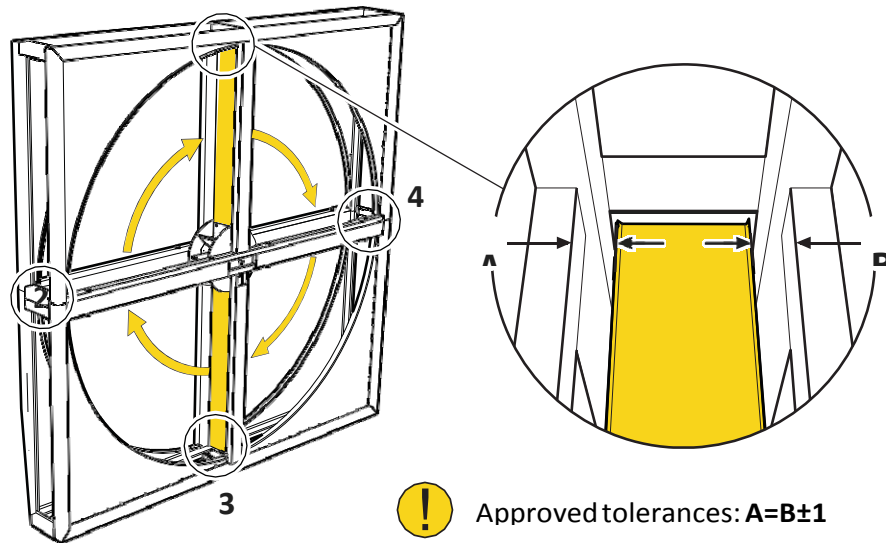

If the tolerance is not achieved, undo the screw at the wing of the hub and adjust the radial wall horizontally.

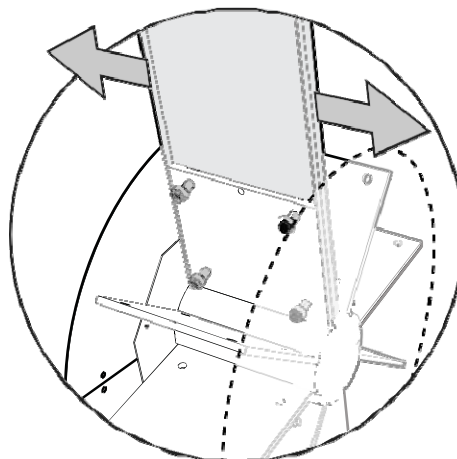

### 9.3.6 Installation of rotor segment and periphery plates.



Uncontrolled movement of radial walls and segments may cause serious injury.

- Secure the radial walls and segments carefully while working.
- Use a rope or strap with a pulley for controlled rotation.
- At least two workers are required when installing segments

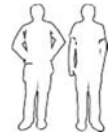

The segments are labelled with their own individual numbers in the centre of the peripheral area, and there is a number at each outer edge of the peripheral area which indicates the segment against which this outer edge must be installed.

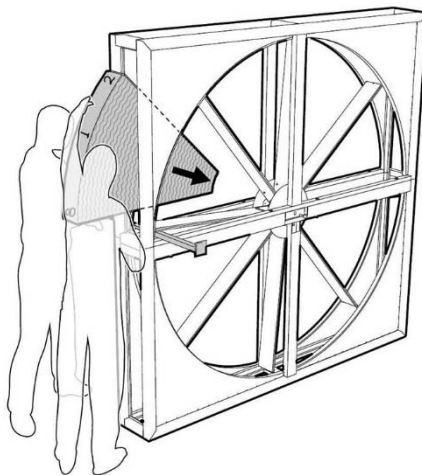
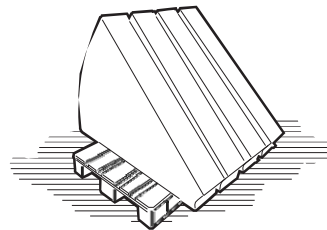
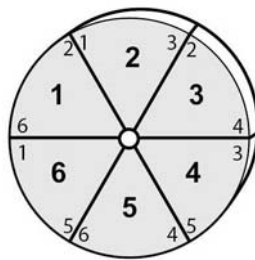

- Make sure that the upper and lower edges of the segment are located within the bent edges of the radial walls.
- Tap gently with a rubber mallet to ensure that the segment is in the right position.

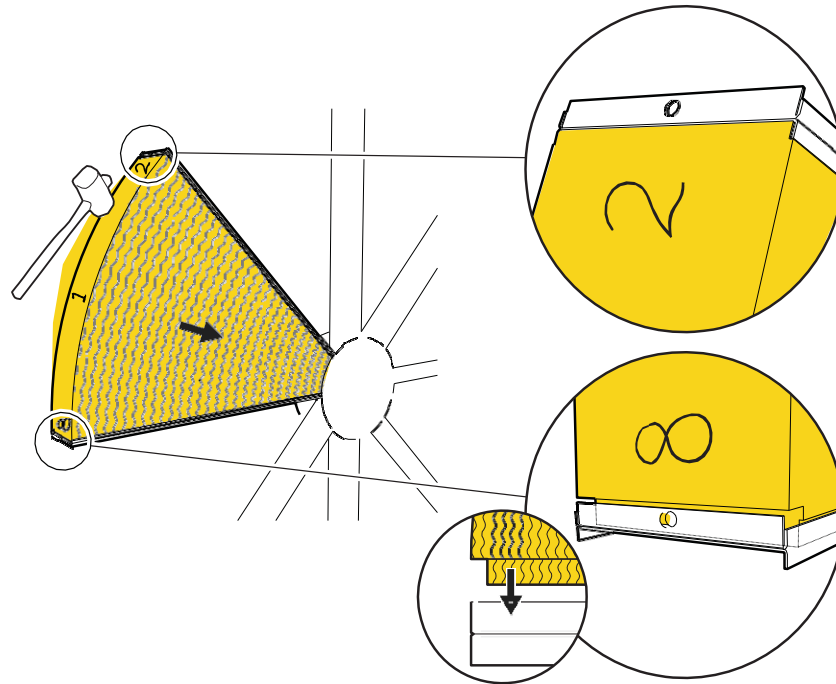

### 9.3.7 Installation, first periphery plate

- Position the first periphery plate. The side with a hole must face up. See figure A.
- Insert a bolt in the hole at the top edge of the periphery plate. See figure A. Do not tighten.
- Insert a bolt in the groove at the lower edge of the periphery plate.
- See figure B. Tighten the bolt. 

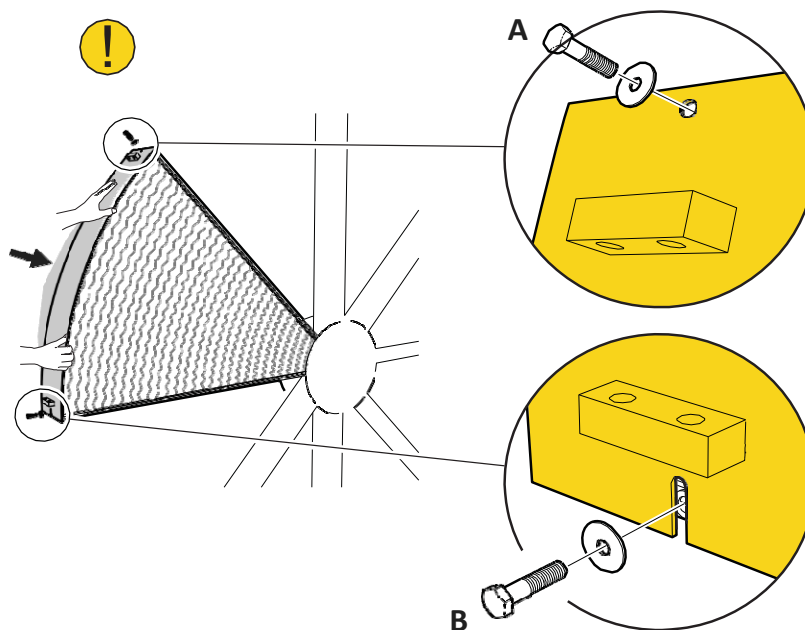

- The bolts are tightened when the adjacent periphery plate has been installed.

### 9.3.8 Installation of next segment

- Rotate the hub, radial walls and segment in order to facilitate the positioning of the next segment.
- Use a pulley with a rope or strap for controlled rotation.

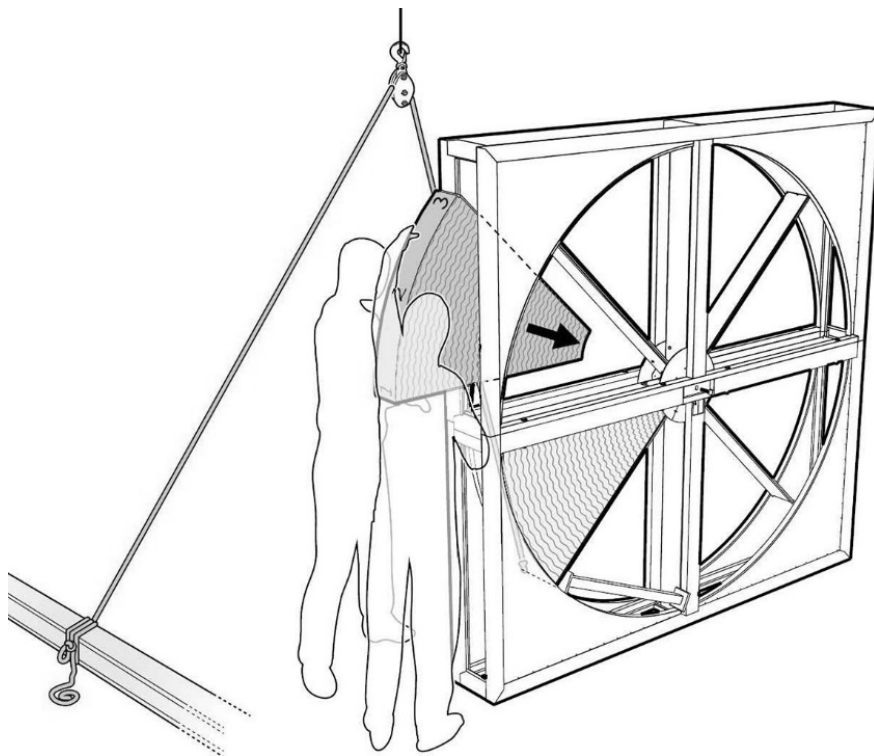
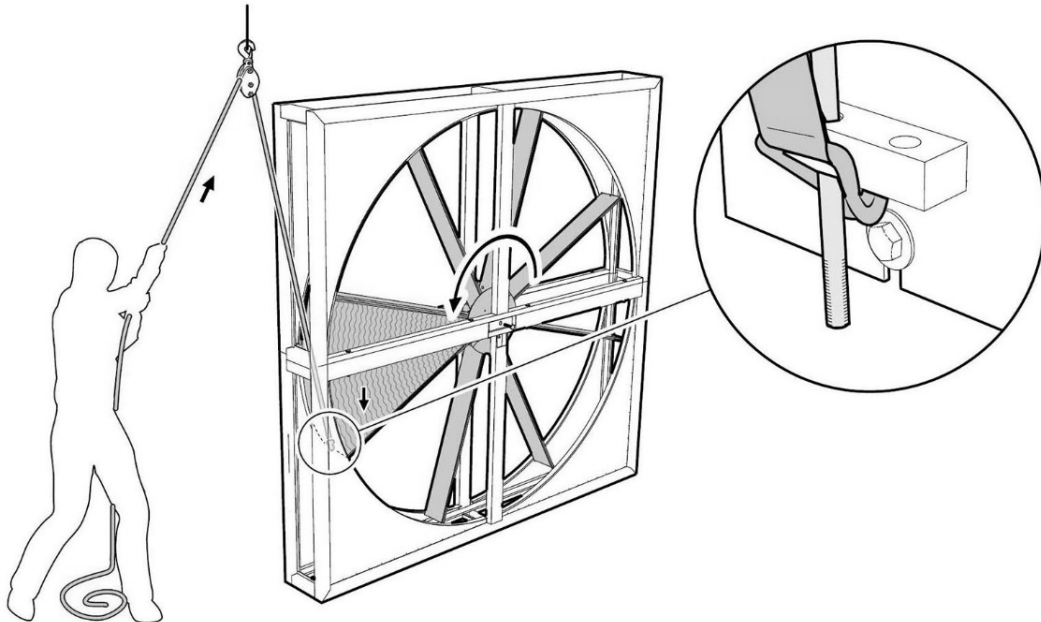

### 9.3.9 Installation, next periphery plate.

- Position the second periphery plate. The side with a hole must face up. See figure A.
- Insert a bolt in the hole at the top edge of the periphery plate. See figure A. Do not tighten.
- The lower edge of the second periphery plate must overlap the first periphery plate and be secured using the bolt installed previously. See figure B.
- Tighten the bolt at the overlap. 

See figure B.

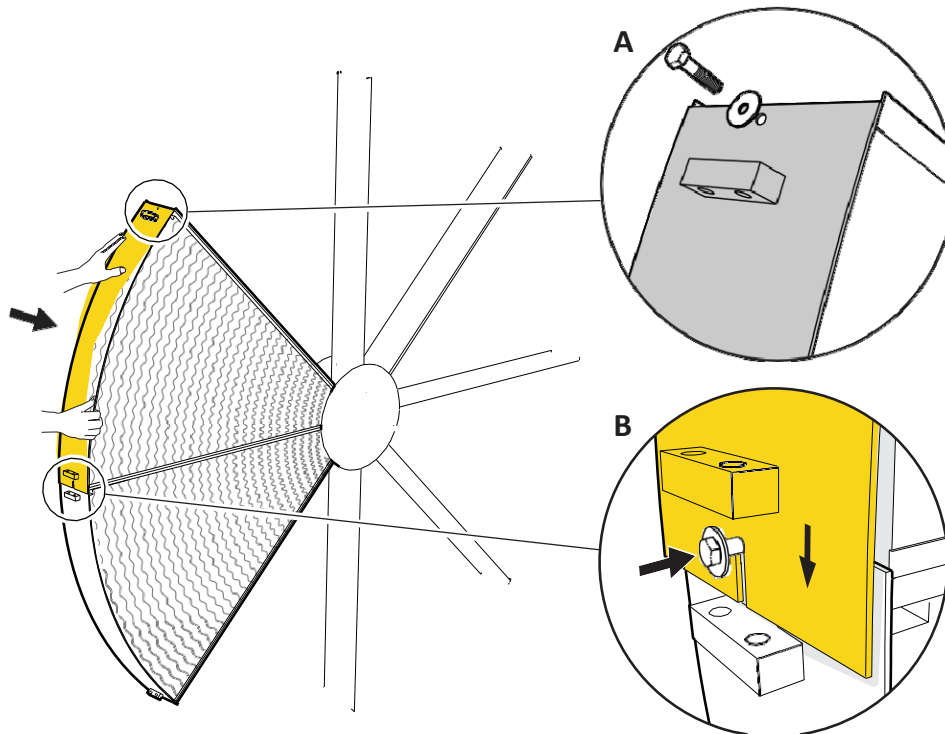

Fasten the periphery plates together with a clamp bolt. Do not tighten.

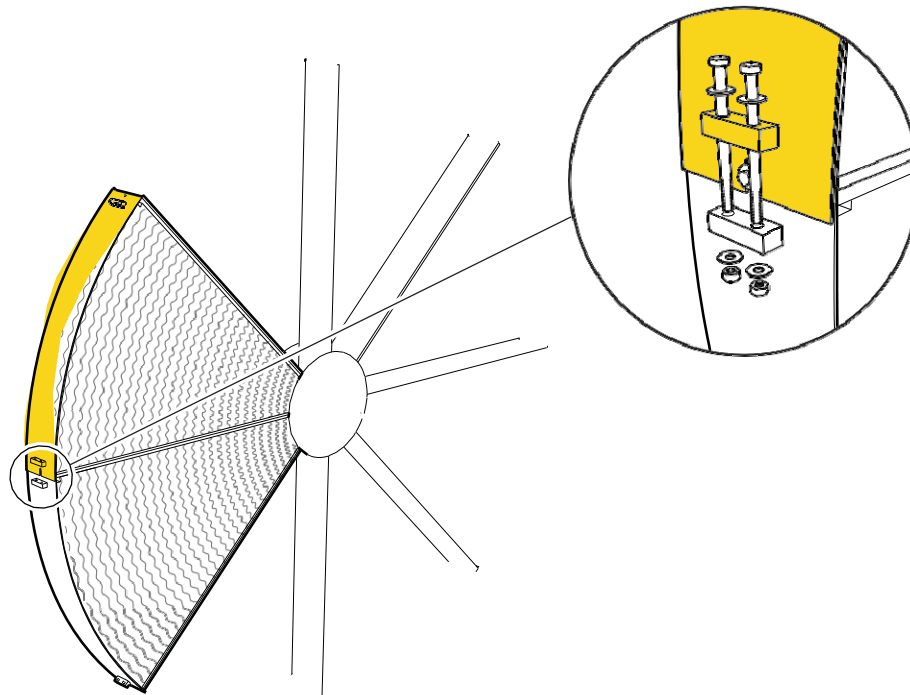

### 9.3.10 Preparation of segments and periphery plates

The periphery plates must be mounted together for preparation of segments and periphery plates. If a standard bolt is insufficient for bringing together the first and last periphery plates, a threaded rod can be used as described below.

- Position the threaded rod and nut. Tighten until an overlap is achieved.
- Tighten the bolt in the overlap.
- Replace the threaded rod with clamp bolts.
- Tighten all bolts which secure the periphery plate in position.
- Use a torque wrench to tighten the bolts.
- Any gaps between the inner and outer segments are sealed with sealant.

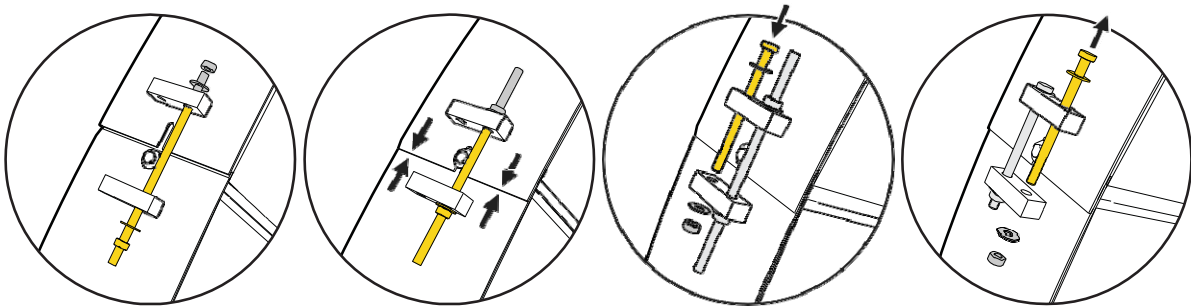
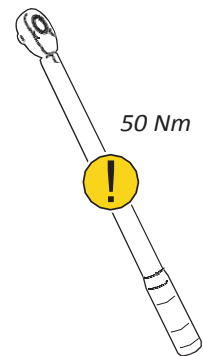

### 9.3.11 Installation and adjustment of brush sealing.

- Use a 3,3 mm drill bit to drill through every fifth hole.
- Install the brush sealing using self-tapping screws.
- The outer thread is for protection and must be removed before installation.

Check that the brush sealing fits tightly. The brush sealing must be adjusted if there is any leakage.

Make sure that the brush sealing is installed with the edge facing up.

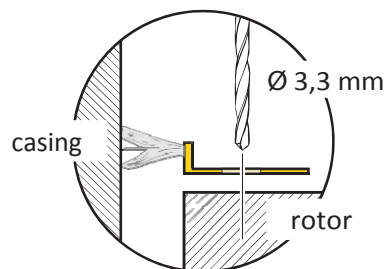

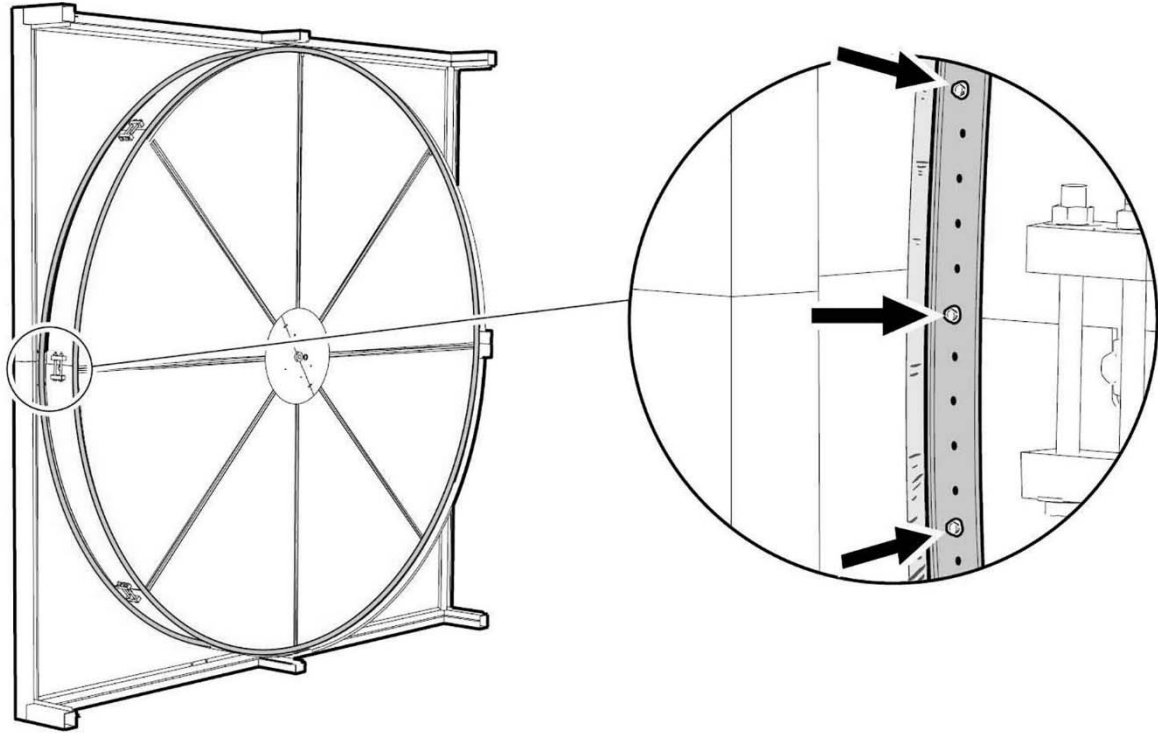

9.4 Installation of motor that turns rotor and sensor for rotation

**Installation of rotor motor and sensor for control of rotation in DVC module after assembly of divided rotor**

Fig. 1





Fig.2

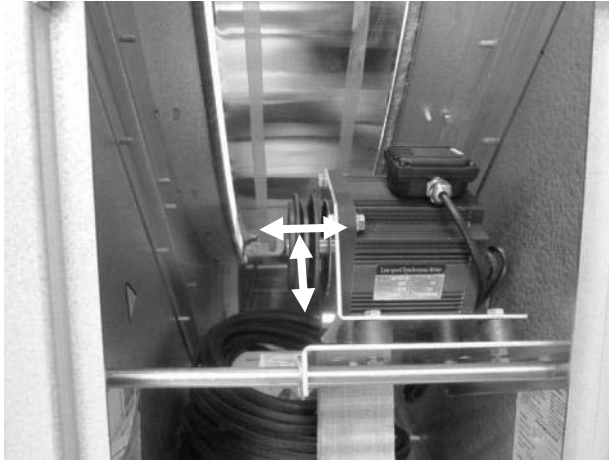

**Fig. 1, 2 and 6**

By delivery of a DVC module with divided rotor, the motor is installed before delivery to the customer

**Fig. 2**

The drive belt must be placed around the rotor and the ideal distance is 9 cm from the 2 sides of the rotor. The rotors are always 20 cm thick. The distance to the drive belt from a side of the rotor must be between 9–11 cm. the 2 sides of the rotor.

Fig.3

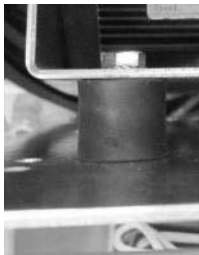

Fig.4



Fig.5



Fig.6

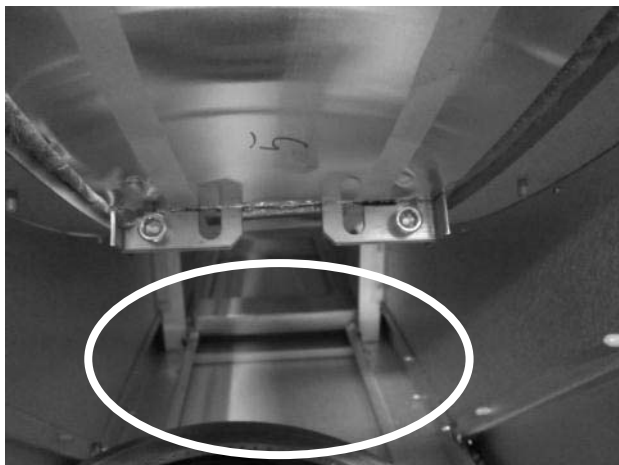

**Fig. 3, 4 and 5**

Motor is mounted on the motor console plate and 4 shock absorbers are mounted under the plate with M8 bolts.

Fig.7



Fig.8

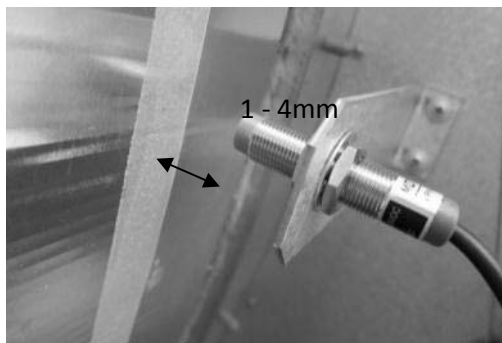
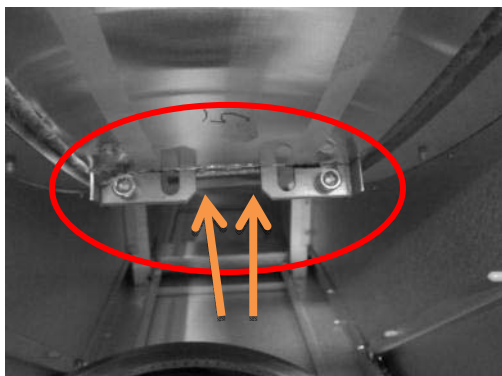

Fig.9



**Fig. 7 and 8**

Sensor for control of rotation must be installed by the installer. Distance must be 1-4 mm between sensor and rotor. Check that the brackets which are used for the assembly of the rotor segments do not hit the sensor.

**Fig. 9**

Pay attention to the heights of the brackets which are used for the assembly of the rotor segments. Please turn the rotor by hand in order to verify that the sensor will not be hit by the brackets.

## **Annex 10. Reversible heat pump for cooling and heating**

### **10.1 DVU-HP section (reversible heat pump unit)**

The air handling unit section – DVU-HP – is a separate section in the air handling unit, containing a complete stand-alone reversible heat pump system (heating and cooling). If the air handling unit was delivered with this section, a separate manual about the heat pump was enclosed in the separate cover.

## **Annex 11. Menu for internal controller in the DVU-HP**

If the air handling unit was delivered with this section, a separate manual about the heat pump was enclosed in the separate cover.

## Annex 12. Connection of fan motor and set-up for frekv. conv.

### 12.1 Connection of fan motor

Delta connection is shown to the left, and star connection is shown to the right.

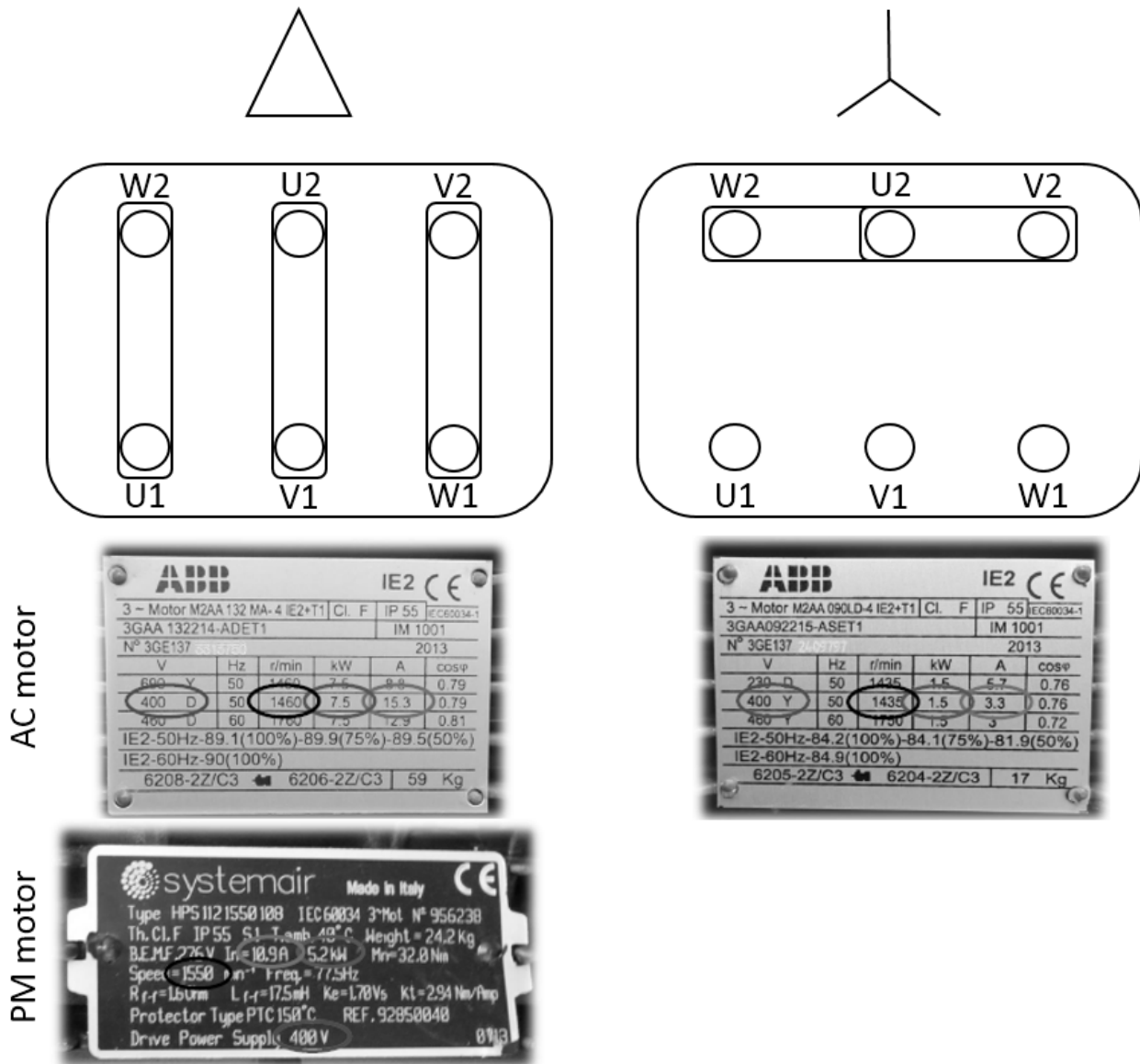

## 12.2 Set-up for Danfoss FC101 for DV-units with AC motors

### SETUP IS DONE IN FACTORY BEFORE DELIVERY

To reload Systemair factory settings from the control panel:

0-50: LCP Copy: [2]

Systemair factory set-up is based on Danfoss initialization.

14-22: Operation mode: [2] Initialisation (Danfoss Initialisation)  
Turn power off and on.

### Systemair factory set-up:

0-01: Language selection:

1-03: Torque characteristic: Single fan: [3] Auto-Energy optim.

With twin fan set-up: [1] Variable Torque

1-20: Motor Power: According to motor plate / order papers

With twin fan set-up total power must be used

1-24: Motor Current: According to motor plate / order papers

With twin fan set-up total current must be used

1-25: Motor Nominal Speed: According to motor plate / order papers

1-42: Motor Cable Length: 3m

1-50: Motor Magnetisation at zero speed.: 0 %

1-52: Min. Speed Normal Magnetisation: 10 Hz

1-73: Flying Start: [1] Enable

1-90: Motor Thermal Protection: [2] Thermistor trip

3-15: Reference 1 Source: [2] Analog input AI54

1-93: Thermistor Source: [1] Analog input AI53

3-03: Maximum Reference: Max. Hz from order papers

3-16 + 3-17: Reference 2- and 3 Source: [0] No function

3-41: Ramp 1 up: 60 Sec.

3-42: Ramp 1 down: 30 Sec.

4-19: Max. Output Frequency: 90Hz

4-14: Motor Speed High Limit: 90Hz

5-12: Terminal 27 Digital input: [0] No operation

5-40.0: Function Relay: [3] Drive ready/remote

5-40.1: Function Relay: [3] Drive ready/remote

6-25: Terminal 54 High Reference: Max. Hz from order papers

14-20: Reset Mode: [2] Automatic reset x 2

0-50: LCP Copy: [1] All to LCP (Copy of Systemair factory settings to panel)

### Connections:

0-10V: terminal 54-55

Start: terminal 12-18

Thermistor: terminal 50-53

Drive ready: terminal 1-2

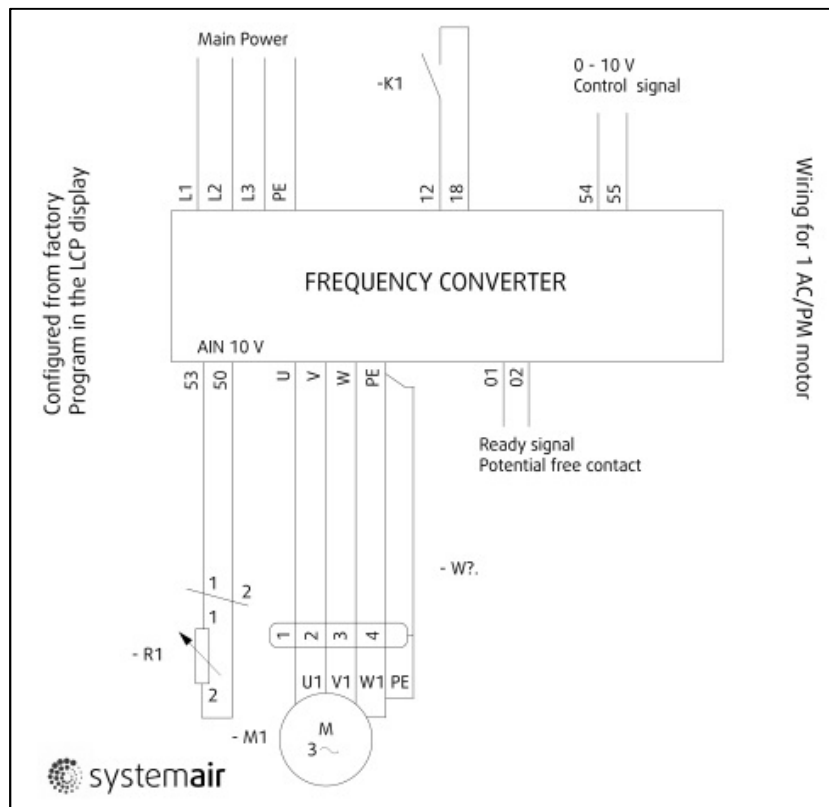
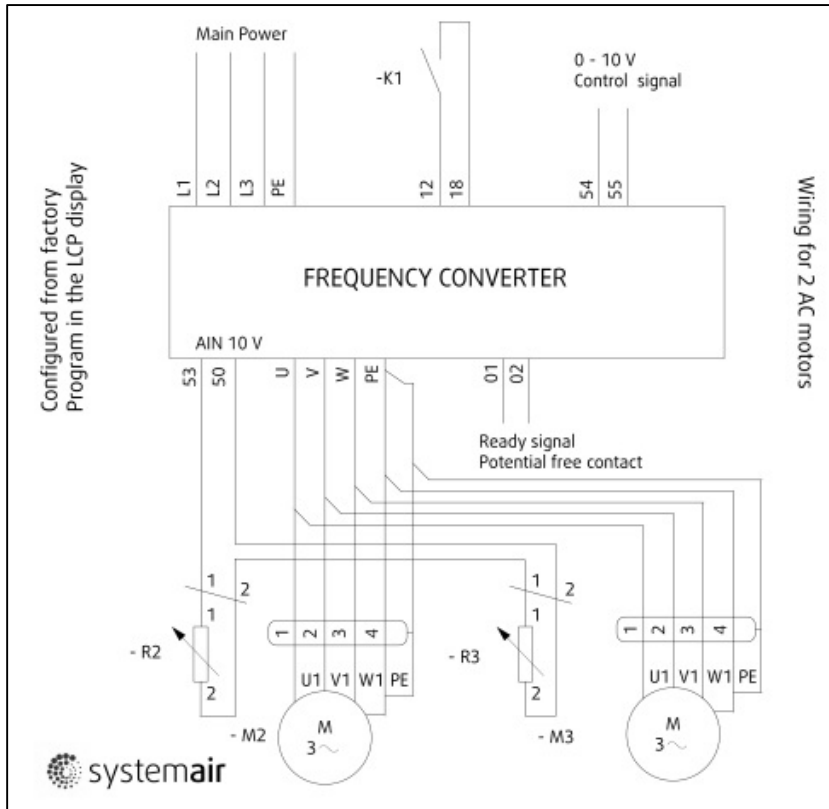

### 12.3 AC-fan operation without thermistor for Danfoss FC101

Systemair factory set-up is based on Danfoss initialization.

14-22: **Operation mode:** [2] Initialisation (Danfoss Initialisation)  
Turn power off and on.

#### Systemair factory set-up:

0-01: Language selection:  
1-03: **Torque characteristic:** [3] Auto-Energy optim.  
1-20: **Motor power:** According to motor plate  
1-24: **Motor Current:** According to motor plate  
1-25: **Motor Nominal Speed:** According to motor plate  
1-29: **Automatic motor adaption (AMA):** [1] Kompl.motor adaption to (Turn power off and on.)  
1-42: **Motor Cable Length:** Order specific  
1-50: **Motor Magnetisation at zero speed.:** 0 %  
1-52: **Min. Speed Normal Magnetisation:** 10 Hz  
1-73: **Flying start:** [1] Enable  
5-40.0: **Function Relay:** [3] Drive ready/remote  
14-03: **Over modulation:** [1] Active  
14-20: **Reset Mode:** [2] Automatic reset x 2  
0-50: **LCP Copy:** [1] All to LCP (Copy of Systemair factory settings to panel)

#### Connections:

0-10V: terminal 54-55  
  
Start: terminal 12-18  
Drive ready: terminal 1-2  
Jumper terminal 12-27



## 12.4 Set-up Danfoss FC101 for DV-units with PM motors

### SETUP IS DONE IN FACTORY BEFORE DELIVERY

To reload Systemair factory settings from the control panel:

0-50: LCP Copy: [2]

**Systemair factory set-up is based on Danfoss initialization.**

14-22: **Operation mode:** [2] Initialisation (Danfoss Initialisation)  
Turn power off and on.

### Systemair factory set-up:

0-01: Language selection:

1-06: Clockwise Direction: [1] Inverse

1-10: Motor Construction: [1] PM, non-salient SPM

1-24: Motor Current: According to motor plate / Schedule

1-25: Motor Nominal Speed: According to motor plate / Schedule

1-26: Motor Cont. Rated torque: According to motor plate / Schedule

1-30: Stator Resistance (Rs): According to motor plate / Schedule

1-37: d-axis inductance (Ld): According to motor plate / Schedule

1-39: Motor Poles: According to motor plate / Schedule

1-40: Back EMF at 1000 RPM: According to motor plate / Schedule

1-42: Motor Cable Length: 3m

1-73: Flying start: [1] Enabled

1-90: Motor Thermal Protection: [2] Thermistor trip

3-15: Reference 1 Source: [2] Analog input AI54

1-93: Thermistor Source: [1] Analog input AI53

3-03: Maximum Reference: According to motor plate / Schedule

3-16 + 3-17: Reference 2- and 3 Source: [0] No function

3-41: Ramp 1 Up: According to schedule for PM motor parameters - below

3-42: Ramp 1 down: According to schedule for PM motor parameters - below

4-19: Max. Output Frequency: According to motor plate / Schedule

4-14: Motor Speed High Limit: According to motor plate / Schedule

5-12: Terminal 27 Digital input: [0] No operation

5-40.0: Function Relay: [3] Drive ready/remote

5-40.1: Function Relay: [3] Drive ready/remote

6-25: Terminal 54 High Reference: According to motor plate / Schedule

14-20: Reset Mode: [2] Automatic reset x 2

2-01: DC brake current: 100 %

2-02: DC braking time: 20.0 sec.

2-07: Parking time: 10,0 sec.

0-50: LCP Copy: [1] All to LCP (Copy of Systemair factory settings to panel)

Connections:

0-10V: Terminal 54-55 and Start: Terminal 12-18 as well as Thermistor: Terminal 50-53

Drive ready: Terminal 1-2

### Schedule for PM motor parameters

Menu:	3-41	3-42	1-24	1-25	1-26	1-30	1-37	1-39	1-40	3-03	4-14	4-19	6-25
Motor type	Ramp up	Ramp down	Amp name plate	Motor RPM rated	Nm Name plate	Ohm (Rf-0)	mH (Lf-0)	Poles	Bemf @ 1000	Max Hz	Max motor Hz	Max motor Hz	Max Hz
HPS 71 3800 18	30	20	1,9	3800	2,0	3,900	11,75	6	67	196	200	200	196
HPS 71 3700 28	30	20	3,0	3700	3,6	2,100	8,25	6	79	191	194	194	191
HPS 71 3300 18	30	20	1,9	3300	2,6	6,250	19,25	6	85	170	173	173	170
HPS 71 3200 30	30	20	3,2	3200	4,2	2,000	8,05	6	84	161	168	168	161
HPS 71 2900 21	30	20	2,4	2900	3,3	4,550	15,40	6	91	143	152	152	143
HPS 71 2800 40	30	20	4,1	2800	6,1	1,750	7,15	6	100	144	147	147	144
HPS 71 2500 29	30	20	3,1	2500	5,0	3,700	13,00	6	105	129	131	131	129
HPS 71 2350 38	30	20	4,2	2350	7,3	2,400	10,85	6	115	120	123	123	120
HPS 90 2650 64	30	30	7,0	2650	9,6	1,150	11,40	8	89	182	186	186	182
HPS 90 2350 76	30	30	8,1	2350	13,0	0,800	10,00	8	103	159	165	165	159
HPS 90 2100 63	30	30	6,7	2100	10,5	1,500	14,75	8	100	142	147	147	142
HPS 90 2050 100	30	30	10,7	2050	19,0	0,700	8,50	8	115	140	144	144	140
HPS 90 1850 84	30	30	8,9	1850	16,0	0,875	11,50	8	117	127	130	130	127
HPS 90 1900 136	30	30	15,3	1900	26,0	0,575	7,25	8	110	127	133	133	127
HPS 90 1700 106	30	30	11,3	1700	22,0	0,575	7,25	8	121	116	119	119	116
HPS 112 1550 108	30	60	11,7	1550	32,0	0,750	8,75	6	178	80	81	81	80
HPS 112 1700 145	30	60	15,5	1700	39,00	0,465	5,45	6	162	88	89	89	88
HPS 112 1350 135	60	60	14,8	1350	44,0	0,570	6,95	6	206	69	71	71	69
HPS 112 1500 187	60	60	19,2	1500	54,0	0,350	5,00	6	182	76	79	79	76
HPS 112 1000 140	60	60	15,0	1000	51,0	0,520	7,75	6	220	54	53	65	54
HPS 132 1250 199	60	60	21,3	1250	69,0	0,320	7,60	6	210	65	66	66	65
HPS 132 1000 202	60	60	21,6	1000	77,0	0,375	9,25	6	230	51	53	53	51
HPS 132 1150 300	60	60	32,1	1150	104,0	0,235	8,00	6	230	58	60	60	58
HPS 132 930 273	60	60	29,4	930	118,0	0,280	9,75	6	261	46	49	49	46

Frequency converter is always necessary for the control of each PM motor

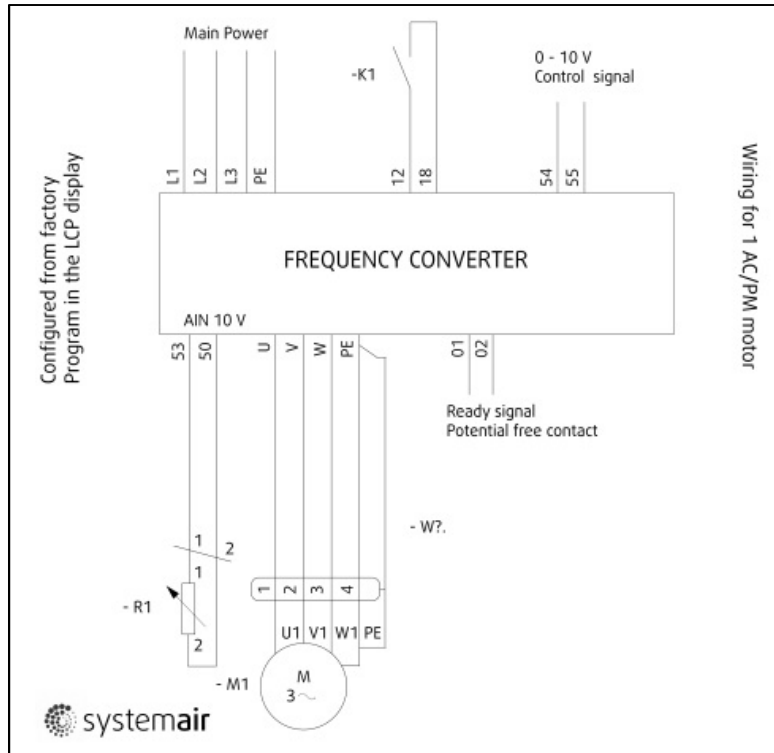

## 12.5 Installation ECblue

### 12.5.1 Connection

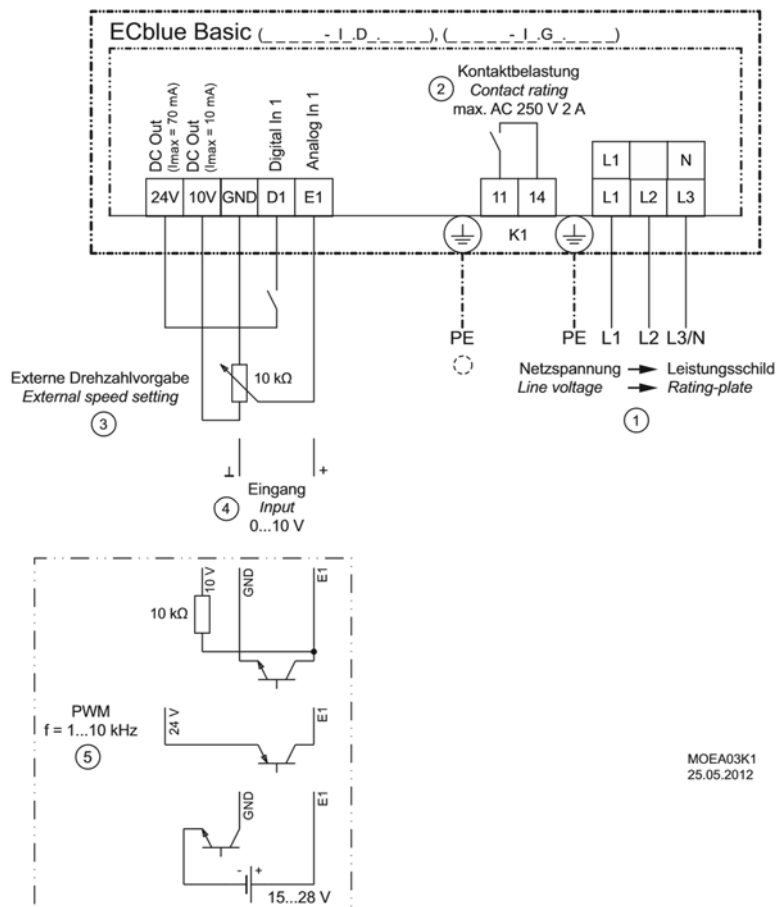

MOEA03K1  
25.05.2012

- 1 Line voltage rating plate
- 2 Contact rating max. AC 250 V 2 A
- 3 External speed setting
- 4 Input 0...10 V
- 5 PWM input, f = 1...10 kHz

For ECblue 3 ~ types and when connecting 1 ~ types between two outer conductors, only all-current sensitive fault current circuit breakers (type B) are allowed ( EN 50 178, Art. 5.2).

## Residual-current-operated protective devices

Terminal	Function / connection
L1, N, PE	Mains connection for 1 ~ types (observe the line voltage indicated rating plate).
L1, L2, L3, PE	Mains connection for 3 ~ types (observe the line voltage indicated rating plate).
11, 14	Relay output "K1" for fault indication. <ul style="list-style-type: none"> <li>For operation the relay is energized, and "14" are bridged. For fault the relay connections "11" is de-energized (Diagnostics / faults).</li> <li>When switching off via enable (D1 = Digital In 1), the relay remains energized.</li> </ul>
E1, GND	Analog input for setting speed via 0 - 10 V or PWM signal*
10V	Voltage supply for speed setting by 10 kΩ potentiometer.
24V	Voltage supply for external devices.
D1, +24V	Digital input for enable.* <ul style="list-style-type: none"> <li>Device "ON" for closed contact.</li> <li>Controller "OFF" with opened contact.</li> </ul>

\*Function for standard factory setting, different presetting possible.

### UL: Input (Line)

- Cu connection leads with the following specifications must be employed:
  - Minimum insulation temperature of 80 °C
  - Terminal tightening torque for field block (L1, N, and/or L1, L2, L3) of 5 - 7 Lb In.  
(Exception: spring-cage terminal for motor size "G" @ line voltage 3 ~ 200...240 V) – Terminal tightening torque of 4.5 Lb In for field block (K1).
  - Terminal tightening torque of 4.5 Lb In for all other field blocks.
  - Terminal tightening torque of 2.2 Lb In for add-on modules.

### 12.5.2 Diagnostic/faults

#### Status Out with flash code

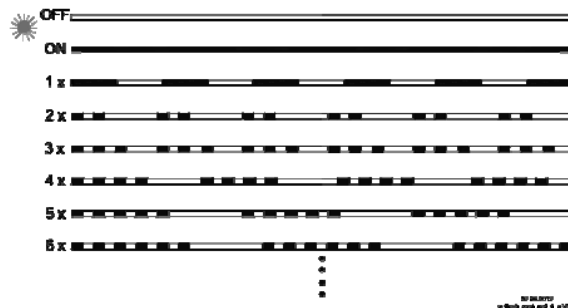

LED Code	Relays K1*	Cause
<b>OFF</b>	de-energized, 11 - 14 interrupted	<b>No line voltage</b>
<b>ON</b>	energized, 11 - 14 bridged	<b>Normal operation without fault</b>
<b>1 x</b>	energized, 11 - 14 bridged	<b>No enable = OFF</b>
<b>2 x</b>	energized, 11 - 14 bridged	<b>Temperature management active</b>
<b>3 x</b>	de-energized, 11 - 14 interrupted	<b>HALL-IC error</b>
<b>4 x</b>	de-energized, 11 - 14 interrupted	<b>Line failure</b> (only for 3 ~ types)
<b>5 x</b>	de-energized, 11 - 14 interrupted	<b>Motor blocked</b>
<b>6 x</b>	de-energized, 11 - 14 interrupted	<b>IGBT Fault</b>
<b>7 x</b>	de-energized, 11 - 14 interrupted	<b>Intermediate circuit undervoltage</b>
<b>8 x</b>	de-energized, 11 - 14 interrupted	<b>Intermediate circuit overvoltage</b>
<b>9 x</b>	energized, 11 - 14 bridged	<b>IGBT cooling down period</b>
<b>11 x</b>	de-energized, 11 - 14 interrupted	<b>Error motor start</b>
<b>12 x</b>	de-energized, 11 - 14 interrupted	<b>Line voltage too low</b>
<b>13 x</b>	de-energized, 11 - 14 interrupted	<b>Line voltage too high</b>
<b>14 x</b>	de-energized, 11 - 14 interrupted	<b>Error Peak current</b>
<b>17 x</b>	de-energized, 11 - 14 interrupted	<b>Temperature alarm</b>

\*K1: programmed function at factory: Fault indication not inverted

## **Annex 13. Commissioning**

See separate cover with annexes 1, 2, 3 and 13

Part number of this manual 90925371 - Version 1.01.13



Systemair A/S  
Ved Milepælen 7  
DK-8361 Hasselager

Tel. +45 87 38 75 00

[mail@systemair.dk](mailto:mail@systemair.dk)  
[www.systemair.dk](http://www.systemair.dk)