

SYSAQUA R32

50 / 60

Air Cooled Water Chillers and Heat Pumps



R32

53 → 62 kW



50 → 60 kW



INSTALLATION INSTRUCTION

NOTICE D'INSTALLATION

INSTALLATIONSHANDBUCH

ISTRUZIONI INSTALLAZIONE

INSTRUCCIONES DE INSTALACIÓN

English

Français

Deutsch

Italiano

Español

CONTENTS

1. GENERAL RECOMMENDATIONS	4
1.1. SAFETY DIRECTIONS	4
1.2. WARNING	5
1.3. EQUIPMENT SAFETY DATA	6
2. INSPECTION AND STORAGE	8
3. WARRANTY	8
4. TECHNICAL SUPPORT AND AFTER SALES SERVICE	8
5. PRESENTATION	8
6. CONTENTS OF PACKAGE	9
6.1. OPTIONAL ACCESSORIES	9
7. DIMENSIONS	9
8. WEIGHT	9
8.1. HANDLING	9
8.1.1. NET WEIGHT	9
8.1.2. GRAVITY CENTER POSITION	9
8.2. OPERATIVE	10
8.2.1. GROSS WEIGHT	10
8.3. GENERAL MAINTENANCE	11
8.3.1. HANDLING WITH A FORKLIFT	11
8.3.1. HANDLING BY SLINGING	12
9. TECHNICAL SPECIFICATIONS	13
9.1. MODELS DESIGNATION	13
9.2. PHYSICAL CHARACTERISTICS - SYSAQUA R32 L - STD VERSION	14
9.3. REFRIGERATION SPECIFICATIONS	18
9.3.1. REFRIGERANT CIRCUIT DIAGRAM	18
9.3.2. REFRIGERANT CHARGE	18
9.3.3. FLUOROCARBON GAS REGULATIONS	18
9.3.4. QUANTITY OF GREENHOUSE GAS	19
9.4. ELECTRIC SPECIFICATIONS	19
9.4.1. SYSAQUA R32 WITHOUT PUMP WITH AC FANS	19
9.4.2. SYSAQUA R32 WITHOUT PUMP WITH EC/HPF FANS	19
9.4.3. ELECTRIC HEATING COIL	19
9.5. OPERATING LIMITS	20
9.5.1. SYSAQUA R32 50-60 L/H COOLING MODE	20
9.5.2. SYSAQUA R32 50-60 H HEATING MODE	20
10. INSTALLATION	21
10.1. SITING THE INSTALLATION	21
10.1.1. SITING DEPENDING ON PREVAILING WIND	21
10.1.2. CONDENSATE WATER MANAGEMENT IN HEATING MODE	21
10.1.3. REDUCTION OF NOISE POLLUTION	22
10.2. CLEARANCE	22
10.3. ATTACHMENT TO THE GROUND	22
11. HYDRAULIC LINKS	23
11.1. MAIN HYDRAULIC CIRCUIT	23
11.2. ANTI-CLOGGING PROTECTION	23
11.3. MINIMUM WATER VOLUME REQUIREMENTS	24
11.3.1. SYSAQUA R32 COOLING ONLY VERSION	24
11.3.2. SYSAQUA R32 HEAT PUMP VERSION	24
11.4. MAXIMUM WATER VOLUME REQUIREMENTS	24
11.5. RINSING THE CIRCUIT	24
11.6. FROST PROTECTION	25
11.7. WATER QUALITY	26
11.8. HEAT INSULATION	27
11.9. FILLING THE SYSTEM WITH WATER	27
12. WIRING DIAGRAM AND LEGEND	28
12.1. WIRING DIAGRAM	28
12.2. LEGEND	28
12.2.1. POWER SUPPLY	28
12.2.2. WIRING DIAGRAM KEY DESCRIPTIONS	28
12.2.3. RANGE AND SETTINGS OF THERMAL PROTECTION / NOMINAL INTENSITY OF THE CONTACTORS (CLASSE AC3)	28
12.3. CRANKCASE HEATER THERMOSTAT ADJUSTMENT RANGE	28
13. ELECTRICAL CONNECTIONS	29
13.1. UNIT POWER SUPPLY	30
13.2. OPTIONS ALL SEASONS AND VARIABLE FLOW PUMP	31
13.3. ELECTRIC HEATING OPTION	31
13.4. ALARM INDICATORS	32
13.5. REMOTE CONTROL	32
13.6. COMMUNICATION	32
14. REGULATION	33
14.1. ORDER OF PRIORITY FOR CONTROL SYSTEMS	33
14.2. USER INTERFACE	33
14.2.1. KEYPAD	33
14.2.2. HOME PAGE	34
14.2.3. MAIN MENU	34
14.2.4. MENUS	34
14.3. INITIAL SETTINGS	35
14.3.1. TIME SETTINGS	35
14.3.2. LANGUAGE SETTINGS	35
14.3.3. DEFINING THE GLYCOL RATE	36
14.4. LAUNCHING THE SYSAQUA R32 SYSTEM	36
14.4.1. CONFIGURING INPUT D1	36
14.4.2. CONFIGURING INPUT D2	37
14.4.3. HEAT/COOL SELECTION	37
14.4.4. SELECTING THE OPERATING MODE	38
14.4.5. USER TEMPERATURE SETPOINTS AND ACTUAL SETPOINTS	38
14.4.6. WATER LAW	39
14.4.7. FIXED SPEED PUMP	40
14.4.8. "VARIABLE PRIMARY FLOW" OPTION	41
14.4.9. REDUCED MODE	44
14.4.10. LIMITED CAPACITY	44
14.5. ALARMS	45
14.5.1. ALARM DETAILS	45
14.5.2. THE LIST OF ACTIVE ALARMS	45
14.5.3. ALARMS HISTORY	46
14.6. SCHEDULE	46

15. COMMISSIONING	47
15.1. PRE-START CHECK LIST	47
15.1.1. VISUAL CHECK	47
15.1.2. ELECTRICAL CHECK	47
15.1.3. HYDRAULIC CHECK	48
15.1.4. REFRIGERATION CHECK	48
15.2. UNIT START-UP	49
15.2.1. PHASE ROTATION PROTECTION	49
15.2.2. FIRST START-UP	49
15.2.3. OPERATING CHECK LIST	49
15.2.4. PUMP MANAGEMENT	50
15.2.5. FINAL CHECK	50
16. IN CASE OF WARRANTY - MATERIAL RETURN PROCEDURE	50
17. ORDERING SERVICE AND SPARE PARTS ORDER	50
18. MAINTENANCE	51
18.1. WEEKLY CHECK	51
18.2. PERIODIC TABLE OF SERVICE AND MAINTENANCE	53
18.3. MAINTENANCE PROCEDURES	55
18.3.1. GENERALITIES	55
18.3.2. REFRIGERANT FLUID DRAINING	55
18.3.3. REFRIGERANT FLUID CHARGE	55
18.3.4. REPAIRS	56
18.3.5. SPECIFIC COMPONENTS	57
18.3.6. WINTER PROTECTION	58
18.3.7. DISPOSAL	59
19. TROUBLE SHOOTING	60



POWER SUPPLY MUST BE SWITCHED OFF BEFORE STARTING WORK IN THE ELECTRIC CONTROL BOX

1. GENERAL RECOMMENDATIONS

The purpose of this Manual is to provide users with instructions for installing, commissioning, using and maintaining the units.

It does not contain the complete description of all the maintenance operations guaranteeing the unit's long life and reliability. Only the services of a qualified technician can guarantee the unit's safe operation over a long service life.

Please read the following safety precautions very carefully before installing the unit.

All refrigerant piping work, electrical work, air-tightness test, and brazing work must be performed by qualified personnel.

1.1. SAFETY DIRECTIONS

Follow the safety rules in forces when you are working on your appliance.

The installation, commissioning, use and maintenance of these units should be performed by qualified personnel having a knowledge of standards and local regulations, as well as experience of this type of equipment.

This appliance has not been designed for use by persons (including children) with reduced physical, sensorial or mental faculties or by persons without any experience or knowledge of heating systems, unless they act under the safety and supervision of a responsible person or have received prior training concerning the use of the appliance.

The unit should be handled using lifting and handling equipment appropriate to the unit's size and weight.

Given the high refrigerant temperatures present at certain points in the cooling circuit, access to the area protected by the panels is strictly reserved for qualified personnel only. These panels are easily opened with a special tool. This tool should be kept by the installers or by the maintenance company.

Any wiring produced on site must comply with the corresponding national electrical regulations.

Make sure that the power supply and its frequency are adapted to the required electric current of operation, taking into account specific conditions of the location and the current required for any other appliance connected to the same circuit.

The unit must be EARTHED to avoid any risks caused by insulation defects.

It is forbidden to start any work on the electrical components if water or high humidity is present on the installation site.

SAFETY SYMBOLS



ELECTRIC VOLTAGE



ROTATING PART



RISK OF CUTTING



RISK OF BURNS



RISK OF ASPHYXIA



SAFETY VALVE VENTS



PRESSURIZED EQUIPMENT



FLAMMABLE GAS

1.2. WARNING

Cut-off power supply before starting to work on the appliance.

When making the hydraulic connections, ensure that no impurities are introduced into the pipe work.

The manufacturer declines any responsibility and the warranty becomes void if these instructions are not respected.

If you meet a problem, please call the Technical Department of your geographical area.

If possible, assemble the compulsory or optional accessories before placing the appliance on its final location. (see instructions provided with each accessory).

In order to become fully familiar with the appliance, we suggest to read also our Technical Instructions.

The information contained in these Instructions are subject to modification without advance notice.

1.3. EQUIPMENT SAFETY DATA

This product contains R32 refrigerant that has a minimal environmental impact, thanks to its low value of Global Warming Potential (GWP).

According to ISO 817, R32 refrigerant is classified as A2L, which is slightly flammable, since the flame propagation rate is low, and non-toxic.

R32 refrigerant can burn slowly when all the following conditions are present:

- The concentration is between the lower and upper flammability limit (LFL & UFL).
- Wind velocity < propagation of flame velocity
- Energy of the ignition source > Minimum ignition energy

Safety Data	Difluoromethane R32
Chemical Formula	CH ₂ F ₂
Toxicity	Low
Classification of substance	Flammable gas - Category 1 - Danger (H220) Gases under pressure - Liquefied gas - Warning (H280)
Critical temperature (°C)	-78,4 °C @ 58,10 Bar
Upper/lower flammability	28,40 Vol. % / 13,10 Vol. %
In contact with skin	Skin contact with the rapidly evaporating liquid may cause tissue chilblains. In case of skin contact with the liquid, warm the frozen tissue with water and call a doctor. Remove contaminated clothing and footwear. Wash the clothing prior to re-use.
In contact with eyes	Vapours have no effect. Liquid splashes or sprays may cause freeze burns. In these cases rinse your eyes with running water or with a solution for eye lavages for at least 10 minutes. Immediately contact a doctor.
Ingestion	In this case, burns may result. Do not attempt to make the patient vomit. If the patient is conscious, rinse the mouth with water. Call a doctor immediately.
Inhalation	In case of inhalation, move the patient to an area with fresh air and provide oxygen if necessary. Perform artificial respiration if the patient has stopped breathing or lacks air. In case of cardiac arrest, perform external cardiac massage. Call a doctor immediately.
Further Medical Advice	Exposure to high concentrations can be dangerous for individuals with cardiac problems, as the presence of catecholamines such as adrenalin in the bloodstream may lead to increased arrhythmia and possible cardiac arrest.
Occupational exposure limits	R32: Recommended limits: 1,000 ppm v/v 8 hours TWA.
Stability	Stable product
Conditions to avoid	Increased pressure due to high temperatures may cause the container to explode. Keep out of the sun and do not expose to a temperature >50°C.
Hazardous reactions	Possibility of dangerous reactions in case of fire due to the presence of F and/or Cl radicals
General precautions	Avoid the inhalation of high concentrations of vapours. The concentration in the atmosphere shall be kept at the minimum value and anyway below the occupational limits. Since vapours are heavier than air and they tend to stagnate and to build up in closed areas, any opening for ventilation shall be made at the lowest level.
Breathing protection	In case of doubt about the actual concentration, wear breathing apparatus. It should be self-contained and approved by the bodies for safety protection.

Safety Data	Difluoromethane R32
Precautions for safe handling: general	<p>Only experienced and properly instructed persons should handle gases under pressure. Use only properly specified equipment which is suitable for this product, its supply pressure and temperature.</p> <p>Purge system with dry inert gas (e.g. helium or nitrogen) before gas is introduced and when system is placed out of service.</p> <p>Purge air from system before introducing gas.</p> <p>Containers, which contain or have contained flammable or explosive substances, must not be inerted with liquid carbon dioxide.</p> <p>Assess the risk of a potentially explosive atmosphere and the need for suitable equipment i.e. explosion-proof.</p> <p>Take precautionary measures against static discharges.</p> <p>Keep away from ignition sources (including static discharges).</p> <p>Provide electrical earthing of equipment and electrical equipment usable in explosive atmospheres. Use non-sparking tools.</p> <p>Refer to supplier's handling instructions.</p> <p>The substance must be handled in accordance with good industrial hygiene and safety procedures.</p> <p>Ensure the complete system has been (or is regularly) checked for leaks before use.</p>
Precautions for safe handling: container	<p>Protect containers from physical damage; do not drag, roll, slide or drop.</p> <p>Do not remove or deface labels provided by the supplier for the identification of the container contents.</p> <p>When moving containers, even for short distances, use appropriate equipment eg. trolley, hand truck, fork truck etc.</p> <p>Secure cylinders in an upright position at all times, close all valves when not in use.</p> <p>Provide adequate ventilation. Suck back of water into the container must be prevented.</p> <p>Do not allow backfeed into the container.</p> <p>Avoid suckback of water, acid and alkalis. Keep container below 50°C in a well ventilated place.</p> <p>Observe all regulations and local requirements regarding storage of containers.</p> <p>When using do not eat, drink or smoke.</p> <p>Store in accordance with.</p> <p>Never use direct flame or electrical heating devices to raise the pressure of a container.</p>
Precautions for safe handling: valves	<p>Leave valve protection caps in place until the container has been secured against either a wall or bench or placed in a container stand and is ready for use.</p> <p>Damaged valves should be reported immediately to the supplier</p> <p>Close container valve after each use and when empty, even if still connected to equipment.</p> <p>Never attempt to repair or modify container valves or safety relief devices.</p> <p>Replace valve outlet caps or plugs and container caps where supplied as soon as container is disconnected from equipment.</p> <p>Keep container valve outlets clean and free from contaminants particularly oil and water.</p> <p>If user experiences any difficulty operating container valve discontinue use and contact supplier.</p> <p>Never attempt to transfer gases from one container to another. Container valve guards or caps should be in place.</p>
Conditions for safe storage, including any incompatibilities	<p>All electrical equipment in the storage areas should be compatible with the risk of a potentially explosive atmosphere. Segregate from oxidant gases and other oxidants being stored. Containers should not be stored in conditions likely to encourage corrosion. Stored containers should be periodically checked for general conditions and leakage. Container valve guards or caps should be in place. Store containers in location free from fire risk and away from sources of heat and ignition. Keep away from combustible material.</p>
Protection clothes	<p>Wear boots, safety gloves and glasses or masks for facial protection.</p>
Behaviour in case of leaks or escapes	<p>Never forget to wear protection clothes and breathing apparatus. Isolate the source of the leakage, provided that this operation may be performed in safety conditions. Any small quantity of refrigerant which may have escaped in its liquid state may evaporate provided that the room is well ventilated. In case of a large leakage, ventilate the room immediately. Stop the leakage with sand, earth or any suitable absorbing material. Prevent the liquid refrigerant from flowing into drains, sewers, foundations or absorbing wells since its vapours may create an asphyxiating atmosphere.</p>
Disposal	<p>The best procedure involves recovery and recycle. If this is not possible, the refrigerant shall be given to a plant which is well equipped to destroy and neutralise any acid and toxic by-product which may derive from its disposal.</p>
Fire-fighting measures	<p>Promptly isolate the scene by removing all persons from the vicinity of the incident if there is a fire. No action shall be taken involving any personal risk or without suitable training.</p> <p>Contact supplier immediately for specialist advice. Move containers from fire area if this can be done without risk. Use water spray to keep fire-exposed containers cool. If involved in fire, shut off flow immediately if it can be done without risk. If this is impossible, withdraw from area and allow fire to burn. Fight fire from protected location or maximum possible distance. Eliminate all ignition sources if safe to do so.</p>
Special protective equipment for fire-fighters	<p>Fire-fighters should wear appropriate protective equipment and self-contained breathing apparatus (SCBA) with a full face-piece operated in positive pressure mode. For incidents involving large quantities, thermally insulated undergarments and thick textile or leather gloves should be worn.</p>
Containers	<p>If they are exposed to the fire, they shall be constantly cooled down by water sprays. Containers may explode if they are overheated.</p>

2. INSPECTION AND STORAGE

At the time of receiving the equipment carefully cross check all the elements against the shipping documents in order to ensure that all the crates and boxes have been received. Inspect all the units for any visible or hidden damage.

In the event of shipping damage, write precise details of the damage on the shipper's delivery note and send immediately a registered letter to the shipper within 48 hours, clearly stating the damage caused. Forward a copy of this letter to the manufacturer or his representative.

Never store or transport the unit upside down. It must be stored indoors, completely protected from rain, snow etc. The unit must not be damaged by changes in the weather (high and low temperatures). Excessively high temperatures (above 60 °C) can harm certain plastic materials and cause permanent damage. Moreover, the performance of certain electrical or electronic components can be impaired.

3. WARRANTY

The appliances are delivered fully assembled, factory tested and ready to operate.

Any modification to the units without the manufacturer's prior approval, shall automatically render the warranty null and void.

The following conditions must be respected in order to maintain the validity of the warranty:

- Commissioning shall be performed by specialised technicians from technical services approved by the manufacturer.
- Maintenance shall be performed by technicians trained for this purpose.
- Only Original Equipment spare parts shall be used.
- All the operations listed in the present manual shall be performed within the required time limits.



THE WARRANTY SHALL BE NULL AND VOID IN THE EVENT OF NON-COMPLIANCE WITH ANY OF THE ABOVE CONDITIONS.

4. TECHNICAL SUPPORT AND AFTER SALES SERVICE

You have a technical question or the unit is under warranty and you need assistance, commissioning, a manufacturer's visit or a rehabilitation quote.

Our technical support and after-sales service are available to assist you:

support@systemair.fr

5. PRESENTATION

All the models in the **SYSAQUA R32** liquid coolers range are produced to state-of-the-art design and manufacturing standards. In this way, they offer guarantees of high performance and reliability as well as the capability of adapting to all types of air conditioning installations operating with both chilled water and glycol solutions (and with hot water for the Heat pump units). The unit, designed for an outdoor mounted application, is not suitable for any use other than those specified in the present manual.

Improper usage of the unit or a use for purposes other than those originally intended, without the prior approval by the manufacturer or its agents, could result in the unit functioning outside its safe operating limits and could present risks to both personnel and property.

SYSAQUA R32 are packaged units, optimized for air conditioning applications.

After the units are assembled, the refrigerating and electrical circuits are tested at the factory in order to guarantee correct operation.

The are filled with an operational refrigerant fluid charge and are subjected to pressure tightness tests.

6. CONTENTS OF PACKAGE

- 1 SYSAQUA R32
- 1 Water filter
- 1 Bag with the documentation

6.1. OPTIONAL ACCESSORIES

Anti-vibration rubber pads

Isolating valve

Spring pads

Lack of water pressure switch

On opening the box, check that all of the accessories required for installation are present.



Caution

The packaging around the SYSAQUA R32 unit must be opened in an outdoor area in case any refrigerant has leaked out in transit.

7. DIMENSIONS

SEE APPENDIX

8. WEIGHT

8.1. HANDLING

8.1.1. NET WEIGHT

			50	60
Without pump		kg	527	547
Single pump	Standard Pressure	kg	+31	+31
	High Pressure	kg	+34	+34
Double pump	Standard Pressure	kg	+44	+44
	High Pressure	kg	+51	+51
Fans	EC	kg	+12	+12
	HPF	kg	+20	+20
S version		kg	+21	+21
Desuperheater		kg	+12	+12
Buffer tank	without electric heating coil	kg	+115*	+115*
	with electric heating coil	kg	+120*	+120*

Note: The values are indicative. Actual data are indicated on the unit label.

* including extra metal frame.

8.1.2. GRAVITY CENTER POSITION

8.1.2.1. WITHOUT BUFFER TANK

		50	60
X _G	mm	1 028	918
Y _G	mm	531	519
Z _G	mm	822	818

8.1.2.2. WITH BUFFER TANK AND DOUBLE PUMP

		50	60
X _G	mm	1 224	1 201
Y _G	mm	511	503
Z _G	mm	767	765

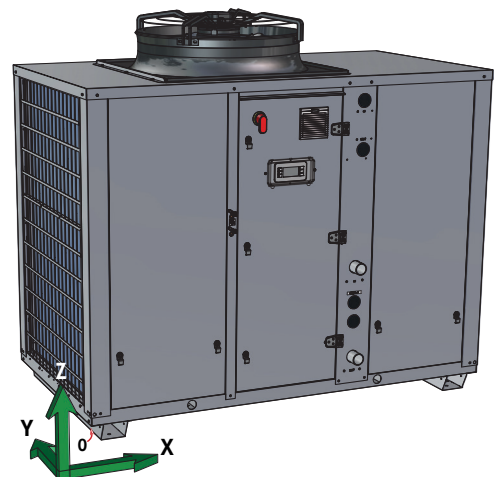

8.2. OPERATIVE**8.2.1. GROSS WEIGHT****8.2.1.1. WITHOUT BUFFER TANK**

		50	60
M	kg	527	547
X _G	mm	1 028	918
Y _G	mm	531	519
Z _G	mm	822	818
P1	kg	151	175
P2	kg	128	142
P3	kg	114	103
P4	kg	135	127
P5	kg	-	-
P6	kg	-	-

8.2.1.2. WITH BUFFER TANK AND DOUBLE PUMP

		50	60
M	kg	976	995
X _G	mm	1 576	1 555
Y _G	mm	449	446
Z _G	mm	666	666
P1	kg	172	175
P2	kg	109	111
P3	kg	132	134
P4	kg	153	156
P5	kg	216	220
P6	kg	194	198

NOTE: for the antivibration position (P1 to P6):

SEE APPENDIX

8.3. GENERAL MAINTENANCE

The method of handling depends on the model of **SYSAQUA R32** and its final destination.

- Take care to avoid any rough handling or impacts when unloading and moving the appliance.
- Before hoisting into position, test lift to insure stability and balance. Avoid twisting or uneven lifting of the units.
- The units shall be carefully inspected before unit installation to make sure this has not happened.
- If these sections have been inspected before leaving the factory. It is therefore important to insure that no bolts, screws or other fixing system are loosened or missing before the commissioning.



Caution

Never submit the metal work (panels, posts) of the **SYSAQUA R32** to handling constraints, as only its base is designed for that purpose.



Caution

Do not tilt the **SYSAQUA R32** 45° or more during handling, as it would be damaged irreversibly.



Caution

Never move the **SYSAQUA R32** on rollers.



Caution

When handling the **SYSAQUA R32**, beware not to damage the finned coil block. Protect it with cardboard or particle panels.

8.2.2. HANDLING WITH A FORKLIFT



When a forklift is used to handle the **SYSAQUA R32 50/60** units, lift them only along their width.

Place a safety wedge between the unit base and the fork lift truck to avoid damaging the unit's structure and casing.



8.3.1. HANDLING BY SLINGING

Lifting is also possible by slinging.

Holes implemented at each end of the unit allow inserting slinging bars along the chassis width.

A spreader must be used to prevent damage to the machine edges.

		50	60
Hole diameter	mm	47	47



Caution

Slings must never touch the unit casing of **SYSAQUA R32**.

SYSAQUA R32 50/60

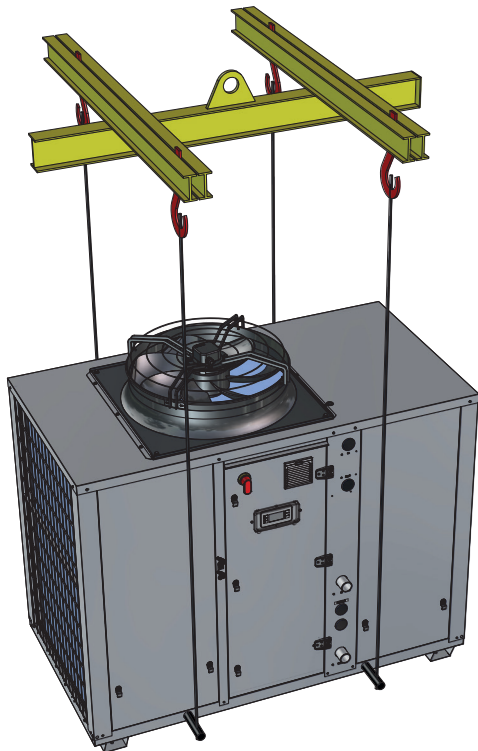

SYSAQUA R32 50/60 WITH BUFFER TANK



9. TECHNICAL SPECIFICATIONS

9.1. MODELS DESIGNATION

SYSAQUA R32 50 . H . 1P-SP . STD . SYS . AC . + . CG . T

① ② ③ ④ ⑤ ⑥ ⑦ ⑦

REP.	Description
①	Size SYSAQUA R32 50 : size 50 SYSAQUA R32 60 : size 60
②	Version L : Cooling only H : Heat pump
③	Hydraulic circuit Empty: Without pump 1P-SP: Single pump standard pressure 1P-HP: Single pump high pressure 2P-SP: Double pump standard pressure 2P-HP: Double pump high pressure
④	Regulation STD : Standard S : Super Low Noise
⑤	Brand SYS : Systemair
⑥	Fan type AC : Standard fans AC motor EC : EC fans HPF : High pressure fans
⑦	Option CG : Outdoor coil protection grid WPS : Low water pressure sensor AVS : Spring dampers AVM : Rubber pads VI : Water isolation valves KM : Refrigerant gauge T : Buffer tank SS : Soft Starter PFC : Power factor capacitor CC : Container transport V2 : Variable pump double speed VP : Variable pump constant outlet pressure DES : Desuperheater EH12 : Electric heating 12kW EH24 : Electric heating 24kW EH36 : Electric heating 36kW 4G : 4G Modem

The nameplate on the machine provides the complete reference and ensures that the unit matches the model that was ordered. It also includes the following information:

- Overall information
 - ✓ Serial number
 - ✓ Year of manufacture
 - ✓ IP protection rating
- Electrical data
 - ✓ Supply voltage
 - ✓ Maximum operating intensity
 - ✓ Starting current
- Thermodynamic data
 - ✓ Type of refrigerant fluid
 - ✓ Refrigerant load in each circuit
 - ✓ Service pressure in the cooling circuit
 - ✓ Service temperatures in the cooling circuit
- Hydraulic data
 - ✓ Nominal flow rate
 - ✓ Maximal water pressure

9.2. PHYSICAL CHARACTERISTICS - SYSAQUA R32 L - STD VERSION

			50	60	
Supply voltage			400V / 3~ / 50Hz		
Number of refrigerant circuit			1		
REFRIGERANT					
Type			R32		
Factory charge			SEE NAME PLATE		
COMPRESSORS					
Type			Scroll		
Number			2	2	
Startup type			DIRECT		
Part load steps		%	0/47/53/100	0/41/59/100	
Crankcase heater		W	70/70	70/66	
EVAPORATOR					
Type			plates		
Number			1		
Water volume			L	6.0	
Cooling Only	Water flow	nominal	m ³ /h	9.2	10.6
		minimum	m ³ /h	6.1	7.1
		maximum	m ³ /h	15.1	17.4
	Water pressure losses		kPa	35.3	46.7
Antifreeze electric heater		W	30	30	
FANS					
Type			AXIAL		
Number			1	1	
STD	Rotational speed	Rpm	870	870	
	Air flow rate	m ³ /h	21 200	21 200	
	Power input each fan	W	2 100	2 100	
EC	Rotational speed	Rpm	780	780	
	Air flow rate	m ³ /h	21 200	21 200	
	Power input each fan	W	1 100	1 100	
HPF	Rotational speed	Rpm	940	940	
	Air flow rate	m ³ /h	21 200	21 200	
	Power input each fan	W	1 600	1 600	
	Static pressure	Pa	85	85	
COILS					
Number			1	1	
Frontal surface			m ²	4.2	
Number of rows			2	2	
WATER CONNECTIONS					
Evaporator	Type		Male gas threaded		
	Inlet diameter	inch	2"	2"	
	Outlet diameter	inch	2"	2"	
Desuperheater	Type		Male gas threaded		
	Inlet diameter	inch	1"1/4	1"1/4	
	Outlet diameter	inch	1"1/4	1"1/4	
BUFFER TANK (OPTION)					
Volume			L	300	
ACOUSTICAL DATA					
Sound power level (STD/EC)		dB(A)	83.2	83.8	
Sound pressure level (STD/EC) (*)		dB(A)	51.4	52.0	
Sound power level (HPF)		dB(A)	87.2	87.3	
Sound pressure level (HPF) (*)		dB(A)	55.4	55.5	

(*) Sound pressure levels calculated at 10 meters. Sound pressure levels refer to ISO 3744 standard, parallelepiped shape.

PHYSICAL CHARACTERISTICS - SYSAQUA R32 L - S VERSION

		50	60	
Supply voltage	400V / 3~ / 50Hz			
Number of refrigerant circuit	1			
REFRIGERANT				
Type	R32			
Factory charge	SEE NAME PLATE			
COMPRESSORS				
Type	Scroll			
Number	2		2	
Startup type	DIRECT			
Part load steps	%	0/47/53/100	0/41/59/100	
Crankcase heater	W	70/70	70/66	
EVAPORATOR				
Type	plates			
Number	1			
Water volume	L	6.0	6.0	
Cooling Only	Water flow	nominal	9.2	10.6
		minimum	6.1	7.1
		maximum	15.1	17.4
	Water pressure losses	kPa	35.3	46.7
Antifreeze electric heater	W	30	30	
FANS				
Type	AXIAL			
Number	1		1	
EC	Rotational speed	Rpm	780	780
	Air flow rate	m ³ /h	21 200	21 200
	Power input each fan	W	1 100	1 100
COILS				
Number	1		1	
Frontal surface	m ²	4.2	4.2	
Number of rows	2		2	
WATER CONNECTIONS				
Evaporator	Type	Male gas threaded		
	Inlet diameter	inch	2"	2"
	Outlet diameter	inch	2"	2"
Desuperheater	Type	Male gas threaded		
	Inlet diameter	inch	1"1/4	1"1/4
	Outlet diameter	inch	1"1/4	1"1/4
BUFFER TANK (OPTION)				
Volume	L	300	300	
ACOUSTICAL DATA				
Sound power level	dB(A)	80.7	81.2	
Sound pressure level (*)	dB(A)	48.9	49.4	

(*) Sound pressure levels calculated at 10 meters. Sound pressure levels refer to ISO 3744 standard, parallelepiped shape.

PHYSICAL CHARACTERISTICS - SYSAQUA R32 H - STD VERSION

				50	60		
Supply voltage				400V / 3~ / 50Hz			
Number of refrigerant circuit				1			
REFRIGERANT							
Type				R32			
Factory charge				SEE NAME PLATE			
COMPRESSORS							
Type				Scroll			
Number				2	2		
Startup type				DIRECT			
Part load steps				%	0/47/53/100	0/41/59/100	
Crankcase heater				W	70/70	70/66	
EVAPORATOR							
Type				plates			
Number				1			
Water volume				L	6.0	6.0	
Heat Pump	Cooling mode	Water flow	nominal	m ³ /h	8.7	10.6	
			minimum	m ³ /h	6.6	7.6	
			maximum	m ³ /h	15.1	17.4	
	Heating mode	Water pressure losses		kPa	31.8	46.7	
			water flow	nominal	m ³ /h	9.3	10.7
				minimum	m ³ /h	6.6	7.6
		maximum	m ³ /h	15.1	17.4		
Antifreeze electric heater				W	30	30	
FANS							
Type				AXIAL			
Number				1	1		
STD	Speed	Rpm	870	870			
	Air flow rate	m ³ /h	21 200	21 200			
	Input power each fan	W	2 100	2 100			
EC	Speed	Rpm	780	780			
	Air flow rate	m ³ /h	21 200	21 200			
	Input power each fan	W	1 100	1 100			
HPF	Speed	Rpm	940	940			
	Air flow rate	m ³ /h	21 200	21 200			
	Input power each fan	W	1 600	1 600			
	Static Pressure	Pa	85	85			
COILS							
Number				1	1		
Frontal surface				m ²	4.2	4.2	
Number of rows				2	2		
WATER CONNECTIONS							
Evaporator	Type			Male gas threaded			
	Inlet diameter	inch	2"	2"			
	Outlet diameter	inch	2"	2"			
Desuperheater	Type			Male gas threaded			
	Inlet diameter	inch	1"1/4	1"1/4			
	Outlet diameter	inch	1"1/4	1"1/4			
BUFFER TANK (OPTION)							
Volume				L	300	300	
ACOUSTICAL DATA							
Sound power level (STD/EC)				dB(A)	83.2	83.8	
Sound pressure level (STD/EC) (*)				dB(A)	51.4	52.0	
Sound power level (HPF)				dB(A)	87.2	87.3	
Sound pressure level (HPF) (*)				dB(A)	55.4	55.5	

(*) Sound pressure levels calculated at 10 meters. Sound pressure levels refer to ISO 3744 standard, parallelepiped shape.

PHYSICAL CHARACTERISTICS - SYSAQUA R32 H - S VERSION

				50	60	
Supply voltage				400V / 3~ / 50Hz		
Number of refrigerant circuit				1		
REFRIGERANT						
Type				R32		
Factory charge				SEE NAME PLATE		
COMPRESSORS						
Type				Scroll		
Number				2	2	
Startup type				DIRECT		
Part load steps			%	0/47/53/100	0/41/59/100	
Crankcase heater			W	70/70	70/66	
EVAPORATOR						
Type				plates		
Number				1		
Water volume				L	6.0	6.0
Heat Pump	Cooling mode	Water flow	nominal	m ³ /h	8.7	10.6
			minimum	m ³ /h	6.6	7.6
			maximum	m ³ /h	15.1	17.4
			Water pressure losses	kPa	31.8	46.7
	Heating mode	Water flow	nominal	m ³ /h	9.3	10.7
			minimum	m ³ /h	6.6	7.6
maximum			m ³ /h	15.1	17.4	
		Water pressure losses	kPa	36.3	48.1	
Antifreeze electric heater			W	30	30	
FANS						
Type				AXIAL		
Number				1	1	
EC	Speed	Rpm	780	780		
	Air flow rate	m ³ /h	21 200	21 200		
	Input power each fan	W	1 100	1 100		
COILS						
Number				1	1	
Frontal surface			m ²	4.2	4.2	
Number of rows				2	2	
WATER CONNECTIONS						
Evaporator	Type			Male gas threaded		
	Inlet diameter	inch	2"	2"		
	Outlet diameter	inch	2"	2"		
Desuperheater	Type			Male gas threaded		
	Inlet diameter	inch	1"1/4	1"1/4		
	Outlet diameter	inch	1"1/4	1"1/4		
BUFFER TANK (OPTION)						
Volume				L	300	300
ACOUSTICAL DATA						
Sound power level			dB(A)	80.7	81.2	
Sound pressure level (*)			dB(A)	48.9	49.4	

(*) Sound pressure levels calculated at 10 meters. Sound pressure levels refer to ISO 3744 standard, parallelepiped shape.

9.3. REFRIGERATION SPECIFICATIONS

9.3.1. REFRIGERANT CIRCUIT DIAGRAM

SEE APPENDIX

9.3.2. REFRIGERANT CHARGE



Caution

This equipment contains fluorinated gas with greenhouse gas effects covered by the Kyoto agreement.

The type and quantity of refrigerating fluid per circuit are indicated on the product plate.

The installer and end user will get informed on local environmental regulations for the installation, operation and disposal of the equipment ; more particularly, for the collection of substances hazardous for the environment (refrigerating fluid, oil, antifreeze, etc.). A refrigerating fluid, whatever it is, must not be vented. Refrigerating fluids must be handled by skilled personnel.



Caution

SYSAQUA R32 units use the R32 HFC refrigerant which is a flammable gas classified A2L (Slightly flammable). This gas is subject to significant safety regulations due to its flammability, so some precautions are required to prevent accidental build-up of refrigerant, especially during the unit charge. Manufacturers recommend use of extract fans while charging, particularly if the outdoor unit is used in an enclosed area. The standard EN378 defines requirements for safe concentration levels of the refrigerants.



Caution

According to the Pressure Equipment Directive (PED) 2014/68/UE and the harmonized standard EN378 (1 to 4), the **SYSAQUA R32** units are ranked Category III.

9.3.3. FLUOROCARBON GAS REGULATIONS

The EC No. 517/2014 regulation covering fluorinated greenhouse gases requires of refrigeration equipment operators to comply with the following five obligations:

1. Installation, servicing, maintenance as well as checking the sealing must be carried out by qualified personnel.
2. The fluorinated gas must be recovered during servicing and maintenance as well as the end of the installation.
3. All the necessary measures must be taken to prevent the leakage of fluorinated gases and any leaks must be repaired as rapidly as possible.
4. Regular checks on any leaks must be performed according to the following conditions:
 - ✓ for equipment containing fluorinated greenhouse gases in quantities greater than or equal to the equivalent of 5 tonnes of CO₂ but less than the equivalent of 50 tonnes of CO₂: at least every twelve months or, if a leak detection system is installed, at least every twenty-four months
 - ✓ for equipment containing fluorinated greenhouse gases in quantities greater than or equal to the equivalent of 50 tonnes of CO₂ but less than the equivalent of 500 tonnes of CO₂: at least every six months or, if a leak detection system is installed, at least every twelve months
 - ✓ for equipment containing fluorinated greenhouse gases in quantities greater than or equal to the equivalent of 500 tonnes of CO₂: at least every three months or, if a leak detection system is installed, at least every six months.
5. A document grouping a description of all the operations carried out on the cooling circuit must be drafted and conserved.



Caution

Non-compliance with one of these obligations constitutes an offense and can result in financial penalties.

Furthermore, compliance of the equipment with the fluorinated gases regulation must be proven to the insurance company.

9.3.4. QUANTITY OF GREENHOUSE GAS

The quantity of greenhouse gas in a **SYSAQUA R32** unit is expressed as an equivalent weight of CO₂ (kg CO₂) and can be calculated as follow:

$$\text{Quantity of greenhouse gas (kg of CO}_2\text{)} = \text{Quantity of gas (kg)} \times \text{gas GWP}$$

with

quantity of gas: refrigerant load in the cooling circuit of the unit (kg), see product plate;

gas GWP: factor for characterizing the Global Warming Potential of a gas (-)

GWP for R32 = 675 (Medium Category: between 300 and 750).

9.4. ELECTRIC SPECIFICATIONS

9.4.1. SYSAQUA R32 WITHOUT PUMP WITH AC FANS

		50	60
Power supply		400V / 3~ / 50Hz	
Maximum current	A	43	48
Total starting current (without soft starter)	A	161	163
Total starting current (with soft starter)	A	119	121

9.4.2. SYSAQUA R32 WITHOUT PUMP WITH EC/HPF FANS

		50	60
Power supply		400V / 3~ / 50Hz	
Maximum current	A	43	47
Total starting current (without soft starter)	A	160	162
Total starting current (with soft starter)	A	119	120

9.4.3. ELECTRIC HEATING COIL

		50	60
Power supply		400V / 3~ / 50Hz	
Low power heating	Power kW	12	12
	Maximum intensity A	19	19
High power heating	Power kW	24	24
	Maximum intensity A	38	38

IMPORTANT

These data are given for guidance only. They must be checked at commissioning according to prevailing standards. They depend on the installation and the cables used.

A main fuse must mandatory be provided on the power supply.

- Fuses not supplied
- Cables not supplied

9.5. OPERATING LIMITS

9.5.1. SYSAQUA R32 50-60 L/H COOLING MODE

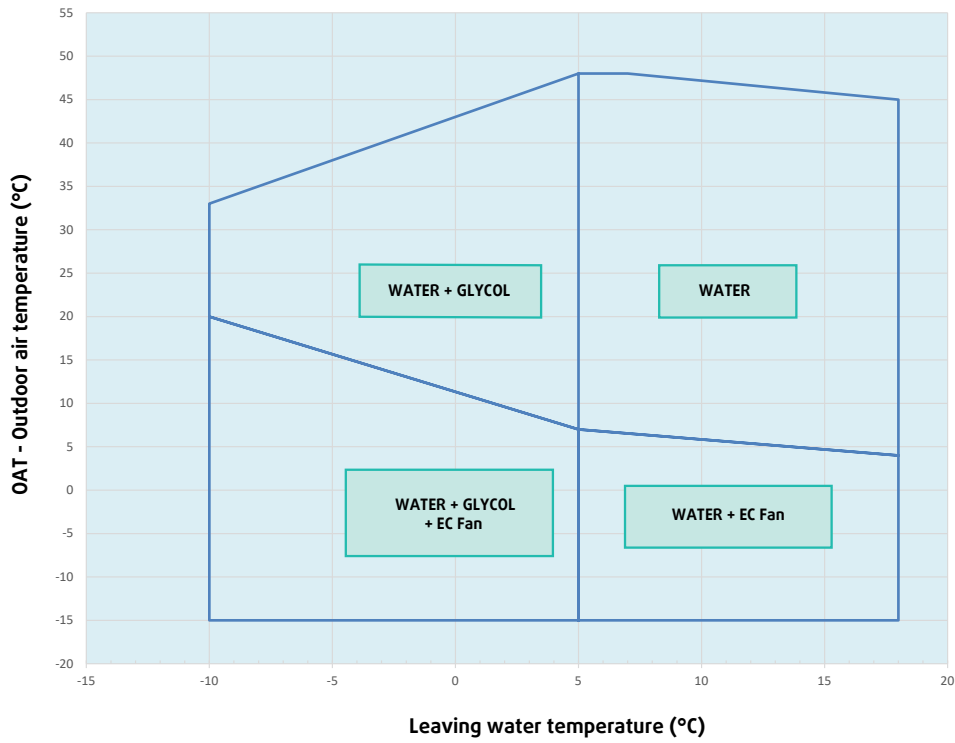

9.5.2. SYSAQUA R32 50-60 H HEATING MODE

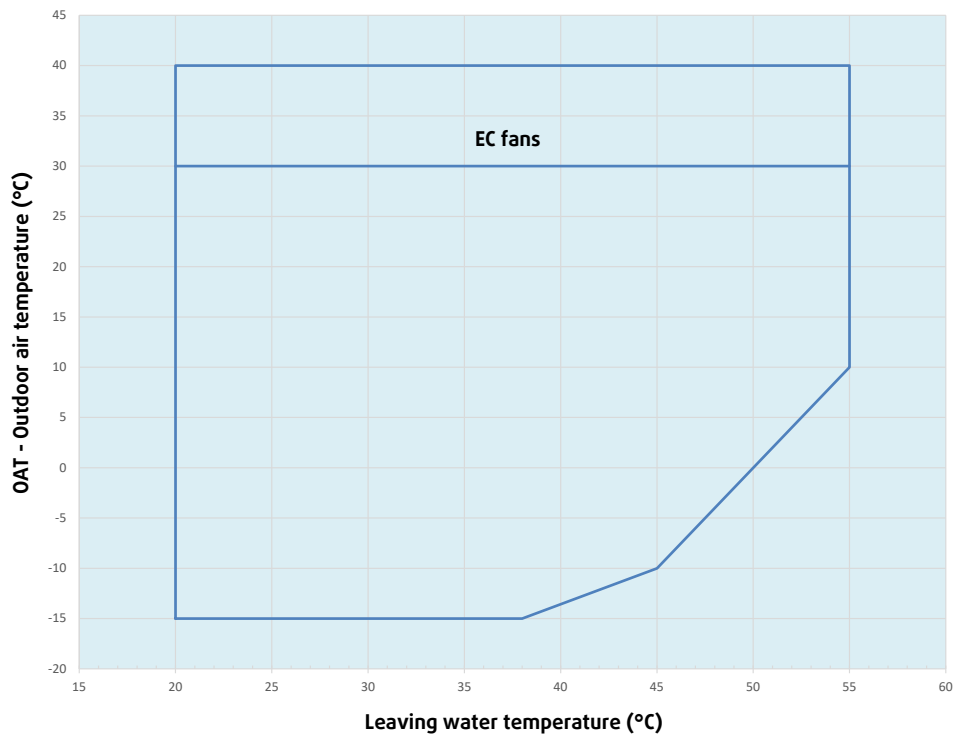

10. INSTALLATION



Caution

The unit is not designed to withstand weights or stresses from adjacent equipment, pipe work or constructions. Any foreign weight or stress on the unit structure could lead to a malfunction or a degradation with dangerous consequences for personnel and property. In such an event, the warranty shall be null and void.



Caution

The unit base shall be arranged as indicated in the manual. There could be a risk of personal injury or damage to property in the event of the unit being incorrectly supported.

10.1. SITING THE INSTALLATION

According to the standard EN378-1 §5.1, the **SYSAQUA R32** units are classified in Category A in terms of access and in Class III in terms of location.

The **SYSAQUA R32** must be installed outdoors with sufficient surrounding clearance to enable unobstructed air circulation through the appliance and access for maintenance work.

Refrigeration systems installed outdoors must be located in such a way that no refrigerant leakage can enter the building or endanger persons and property. The refrigerant must not be able to spill into a ventilation duct, under a door, a hatch or similar opening in the event of a leak. When a shelter is provided for refrigeration equipment situated in the open air, this shelter must be equipped with a natural or forced ventilation device.



Information

SYSAQUA R32 units can also be installed in a machine room in accordance with local and national regulations and the standards of EN 378-3:2016. This regulation also applies to machines installed outside where any release of refrigerant may stagnate.



Caution

Do not expose the **SYSAQUA R32** to rejections from chimneys or vents. Fumes charged with soot or grease as well as acid rejections are likely to clog or damage the condenser irreversibly. This would cancel the warranty.

10.1.1. SITING DEPENDING ON PREVAILING WIND

In the case of the unit being sited in areas exposed to high winds, you must avoid the wind hitting the fan blowing surface areas directly to avoid any risk of recycling cooled air. Exchanger fan operation can be disrupted by strong winds, which can cause de-icing problems and fan malfunctions.



Caution

Unit operation depends on air temperature. Any recycling of air extracted by the fan lowers the air intake temperature across the exchanger fins and alters the standard operating conditions.

10.1.2. CONDENSATE WATER MANAGEMENT IN HEATING MODE

Depending on temperature and outdoor air humidity conditions, water vapour contained in the air can condense on the finned heat exchanger and even form ice under low outdoor temperature conditions (around $< 5^{\circ}\text{C}$). This condensate water and defrosted water runs off via outlets provided under the exchanger. To aid water run-off and avoid frozen water remaining in the appliance in winter, we recommend that it is mounted at a height of around 10cm off the ground. In this way, these water can run off freely and be absorbed into the ground or channelled to a basin built under the appliance in order to protect the environment.

In areas where outdoor temperatures fall below 1°C , the system can be equipped with a condensate anti-freeze protection system (e.g. a heated pipe sheath, Not supplied).

10.1.3. REDUCTION OF NOISE POLLUTION

In order to contain noise levels, we equip our appliances with quiet fans and encase the technical compartment in sound-proofed panels. However, noise levels can be reduced even further by following a few installation precautions:

- Do not install the appliance near a window.
- Do not install the unit in enclosed or confined yards, narrow locations where noise may be reflected on walls.
- Install the rubber pads supplied or anti-vibration pads (available as an option) under the appliance.
- Do not join the concrete slab supporting the appliance to the structure of the dwelling (structure-borne noise transmission).
- Electrical and hydraulic connections to the unit must be flexible to avoid transmitting vibrations.



Information

The operator must ensure that hearing protection (PPE and CPE) is properly implemented in the event of prolonged work near the unit.

10.2. CLEARANCE

When choosing the location for the **SYSAQUA R32**, take care to leave sufficient free clearance on all sides to ensure easy access for maintenance work. The minimum free clearance dimensions indicated must be observed to ensure both proper system operation and allow access for maintenance and cleaning.

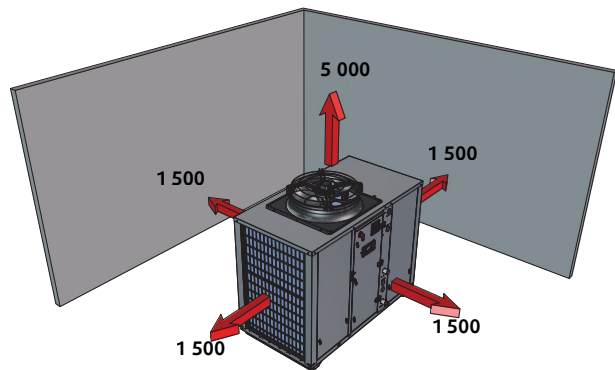

Caution

When several **SYSAQUA R32** units are installed, ensure proper clearance is implemented around the condensers specific to each machine.

10.3. ATTACHMENT TO THE GROUND

The surface of the floor or structure located under the **SYSAQUA R32** must be flat, and with sufficient strength to withstand the unit's weight with its full liquid load, and occasional presence of maintenance equipment.

The **SYSAQUA R32** does not require anchoring on the foundations, except in regions exposed to a high earthquake risk or if the device is installed on a high level on a steel frame.

For normal applications, rigidity of the **SYSAQUA R32** and the positions of supports allow for an installation minimizing vibrations. However, the installers can use anti-vibration rubber pads (supplied in option).

When fitting anti-vibration pads, refer to the manual supplied with the kit.

SYSAQUA R32 50/60

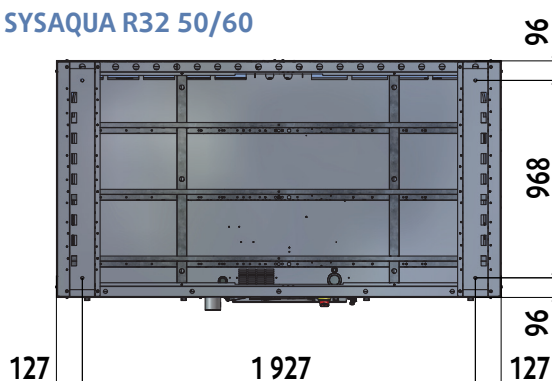

SYSAQUA R32 50/60 WITH BUFFER TANK

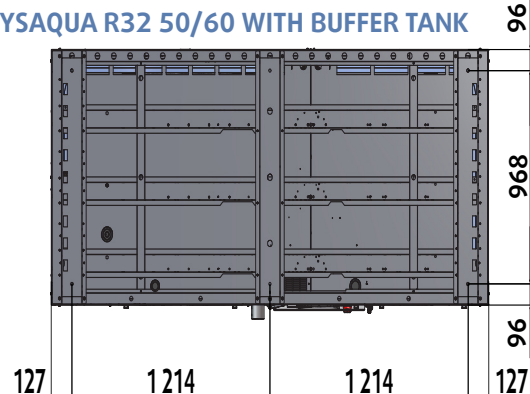

11. HYDRAULIC LINKS



Caution

When choosing and installing water pipes, you must consult and observe all current local standards, regulations and instructions.

11.1. MAIN HYDRAULIC CIRCUIT



Caution

The mains hydraulic circuit will provide a constant water flow on the refrigerating fluid/water plate exchanger and in case of load variation.

You must design the pipe network with the minimum number of bends and keep the number of changes in height to the strict minimum. This will reduce installation costs and ensure optimum system performance. The pipe network must include:

- A vibration elimination system (e.g.: link hoses) on all pipes connected to the appliance in order to reduce vibrations and noise transmitted to the building fabric.
- A balancing valve on the water outlet pipe in order to adjust the water flow.
- Stop cocks to isolate the hydraulic circuit during maintenance.
- Manual or automatic bleed valves at the highest point on the water circuit.
- Draining connectors at all low points to allow complete circuit draining.
- A circulation pump guaranteeing flow necessary for the operation of the **SYSAQUA R32** unit if the model does not already include a pump.
- A diaphragm expansion tank fitted with a safety and draining valve must be visible.
- A low water pressure sensor to secure the water pump against cavitation if the water pressure in the circuit decreases.
- The installation of thermometers and pressure gauges on the heat exchanger inlet and outlet to facilitate day-to-day controls and system maintenance.
- An element ensuring ground continuity of all piping. An unbalance of grounding connection points can cause corrosion electrolytic.



Caution

The expansion tank must be dimensioned to be able to absorb an expansion corresponding to 2% total volume of water contained in the installation (exchanger, piping, installations and buffer tank, if present).



Caution

THE WARRANTY DOES NOT COVER DAMAGE DUE TO CORROSION RESULTING FROM ELECTROLYTIC PHENOMENA.

11.2. ANTI-CLOGGING PROTECTION



Caution

To avoid any risk of foreign bodies entering the appliance and to guarantee operating performance, IT IS IMPERATIVE TO INSTALL WATER FILTER on the SYSAQUA R32 inlet pipe.

Failing that, **SYSAQUA R32's** heat plate exchanger would clog up soon after being commissioned. Proper operation of the **SYSAQUA R32** would be disturbed by a reduced water flow or the partial blockage of certain heat plates. The heat plate exchanger could be **IRREVERSIBLY** damaged if the water flow were not sufficiently high. A link smaller than or equal to 800µm is recommended

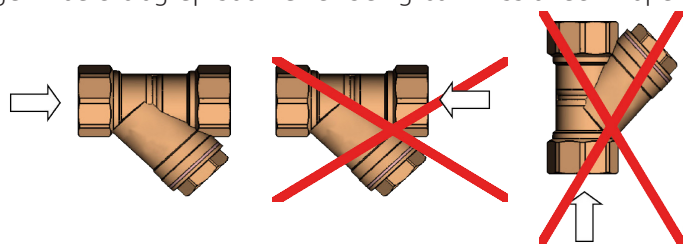

Caution

THE MANUFACTURER'S WARRANTY IS VOID IF THE FILTER SUPPLIED WITH THE SYSAQUA R32 IS NOT INSTALLED TO PROTECT THE APPLIANCE

11.3. MINIMUM WATER VOLUME REQUIREMENTS

To ensure that the system operates correctly you must use suitably sized and properly routed pipes for the hydraulic links between the **SYSAQUA R32** and the mains network. Proper operation of the regulation and safety devices is ensured only when the water volume is sufficient.

For refrigeration only units, the total volume on the level of the primary water circuit must never below:

- application air conditioning
 - ✓ 3.5 L/kW refrigeration power
- application process
 - ✓ 10 L/kW refrigeration power

For reversible units, a water volume equal to 12.5 L/kW is recommended, so that energy reserves are full enough to ensure the defrosting cycle without any discomfort for the end user.

If the total volume of the primary hydraulic circuit does not allow to reach these recommendations, a buffer tank must be added to the installation to increase the water volume up to the value required.

If the unit runs with a low volume of water (with air treatment plant...) or if it is used for industrial processes, a buffer tank is compulsory to guarantee sufficient thermal inertia and satisfactory temperature stability.

Internal water tank:

- **SYSAQUA R32 50-60** ⇨ 300L

11.3.1. SYSAQUA R32 COOLING ONLY VERSION

		50	60
Minimum water volume in the system application air conditioning	without buffer tank	L 184	211
	with buffer tank	L /	/
Minimum water volume in the system application process	without buffer tank	L 526	604
	with buffer tank	L 226	304

11.3.2. SYSAQUA R32 HEAT PUMP VERSION

		50	60
Minimum water volume in the system	without buffer tank	L 668	769
	with buffer tank	L 368	469

11.4. MAXIMUM WATER VOLUME REQUIREMENTS

The maximum water volume is limited by the sizing of the unit's expansion tank and/or the expansion tank present in the facility's hydraulic circuit. Expansion tanks must be sized according to the glycol percentage in the hydraulic circuit.

The expansion tank should be installed at the pump suction, and the pressure inside will be adjusted by taking into account the whole hydraulic circuit.

The volume of the expansion tanks selected with Single pump and double pump options is:

		50	60
Volume of the expansion tank supplied with hydraulic options	L	12	12

11.5. RINSING THE CIRCUIT



Caution

Before filling the installation, check it and remove any contamination such as sand, stone, welding chips and other materials likely to damage the **SYSAQUA R32**.

Fully rinse all water pipes before final connection to the **SYSAQUA R32**.

When using an off-the-shelf acid rinsing solution, implement a temporary branching around the **SYSAQUA R32** to prevent damaging internal components (particularly the plate exchanger, flow switch, pump...).

11.6. FROST PROTECTION

If the **SYSAQUA R32** is exposed to ambient temperatures between 1°C and -18°C, protect the water circuit against frost.



Caution

THE USE OF A GLYCOL-BASED SOLUTION IS THE ONLY EFFECTIVE FROST-PROTECTION MEANS

The glycol-based water solution must be sufficiently concentrated to ensure appropriate protection and prevent ice from forming at the minimum outdoor temperatures planned for the installation. Take precautions when using non inert MEG antifreeze solutions (Mono Ethylene Glycol or MPG Mono Propylene Glycol). With this type of antifreeze solution, corrosion may occur in the presence of oxygen.

Contact glycol resellers to ensure that its characteristics are compatible with environmental directive applicable on site (this is not under manufacturer responsibility).



Caution

The glycol percentage in the installation's hydraulic circuit must be entered in the regulation upon start-up. This parameter setting changes the safety and alarm triggering threshold limits. An incorrect value may cause malfunctions and a destruction of the unit's heat exchanger.



Avertissement

It is strongly recommended to post, on the electric box of the unit, glycol type and concentration in the hydraulic circuit.

The glycol-based solution slightly modifies the installation's performance, particularly in terms of load loss:

Minimum outdoor temp.		°C	5 > T > 0	0 > T > -5	-5 > T > -10	-10 > T > -30
Mono Ethylene Glycol concentration		%	10	20	30	45
Correction factor	load loss		1.070	1.160	1.235	1.368
	water flow		1.015	1.050	1.085	1.169
	thermodynamic power		0.995	0.985	0.970	0.949

Minimum outdoor temp.		°C	5 > T > 0	0 > T > -5	-5 > T > -10	-10 > T > -27
Mono Propylene Glycol concentration		%	10	20	30	45
Correction factor	load loss		1.112	1.175	1.290	1.520
	water flow		1.005	1.030	1.067	1.162
	thermodynamic power		0.991	0.977	0.945	0.894

Example for a solution with 20% Mono Ethylene Glycol:

- Increase the pressure drop : with glycol = 1.160 x without glycol
- Increase the flow rate : with glycol = 1.050 x without glycol
- Decrease the capacity : with glycol = 0.985 x without glycol

Draining the water circuit is not recommended for frost protection, for the following reasons:

- The water circuit will rust, which will shorten its lifetime.
- Water will remain at the bottom of the plate exchangers and freezing may cause damage.



Caution

Never fill the hydraulic circuit with pure glycol. Maximum glycol concentration is 45%. The water and glycol mixture must be precisely prepared before filling the hydraulic circuit. If the mixture is too much concentrated, the hydraulic could be damaged and the unit **SYSAQUA R32** should not perform normally. **In this case, unit guarantee will be cancelled.**



Caution

For heat pump models, if the outdoor temperature is likely to fall below +1°C, provide a system to prevent the condensates from freezing (e.g. heating cord).

11.7. WATER QUALITY

The water must be analyzed; the hydraulic network system installed must include all elements necessary for water treatment: filters, additives, intermediate exchangers, drain valves, vents, check valves, etc., according to the results of the analysis.



Caution

The SYSAQUA R32 must not run on a network with open loops, likely to cause incidents related to oxygenation, or with non treated table water.

Using improperly treated or non treated water in the **SYSAQUA R32** may cause scaling, erosion, corrosion or algae or sludge deposits in the exchangers. Refer to a specialist skilled in water treatment to determine any treatment to apply. The manufacturer will not be held liable for damages caused when non treated or improperly treated water, demineralized water, salty water or sea water are used.

Apply the following guidelines :

- No NH_4^+ ammonium ions in the water, highly detrimental to copper. <10mg/l
- Cl⁻ chloride ions are detrimental to copper with a risk of puncture by picking corrosion. <10mg/l.
- SO_4^{2-} sulphate ions may cause perforating corrosion. < 30mg/l.
- No fluoride ions (<0.1 mg/l)
- No Fe^{2+} and Fe^{3+} ions, particularly in case of dissolved oxygen. Fe < 5mg/l with dissolved oxygen < 5mg/l. The presence of these ions with dissolved oxygen indicates corrosion of steel parts, likely to generate corrosion of copper parts under Fe deposits, particularly in the case of multitubular exchangers.
- Dissolved silica: silica is an acid element of water and may also cause corrosion. Content < 1mg/l.
- Water hardness: Values between 10°fH and 30°fH may be recommended. This facilitates scaling deposits likely to limit copper corrosion. Excess TH values may lead to clogging the pipes.
- TAC < 100
- Dissolved oxygen: Prevent any sudden change in the water's oxygenation conditions. Also, avoid deoxygenating water by sparging inert gas as well as overoxygenating it by pure oxygen sparging. Disturbing oxygenation conditions destabilizes copper hydroxides and particle salting-out.
- Electrical Resistivity - Conductivity: The higher the resistivity, the slower the corrosion. Values above 3000 ohm/cm are preferred. A neutral environment favours maximum resistivity. For electrical conductivity, values around 200-600 S/cm can be recommended.
- pH: neutral pH at 20°C (7 < pH < 9)



Caution

If the water circuit is to be drained for a time exceeding one month, the circuit must be fully charged with nitrogen to prevent any risk of corrosion by differential venting.



Caution

The manufacturer is not liable for recommendations in terms of water treatment (call a specialized company).

However, this matter has a critical nature, and particular care must be given to ensure that the type of treatment applied is effective.

The liability of the manufacturer or its representative will not be sought when non treated water or non compliant quality water is used.

11.8. HEAT INSULATION

To guarantee proper energy efficiency and compliance with current standards, water pipes passing through uninhabited zones should be properly lagged to retain heat.

To achieve correct insulation with conductivity of 0.04 W/mK, lag the pipes with insulating material with a radial thickness between 25mm and 30 mm.

11.9. FILLING THE SYSTEM WITH WATER



Caution

FILLING OR DRAINING THE WATER CIRCUIT MUST BE PERFORMED BY SKILLED PERSONS USING THE APPROPRIATE DEVICES ON THE EXTERNAL HYDRAULIC CIRCUIT BY THE INSTALLER.

It is important to ensure that the mains water supply pressure is sufficient to fill the installation.

Once the installation is complete and after having clean and rinsed out the circuit network, you must fill the water circuit in accordance with current professional standards until you obtain the service pressure which will be:

0.5 bar < Service Pressure < 2.5 bar

A 3 bar safety valve is mounted in the unit when hydraulic options are selected (single or double pump).

Always check that the manual or automatic air drains are installed at all the high points of the hydraulic network.

When two or three units are connected in parallel, it is recommended that the return circuit connections are reversed (Tickelman loop system) in order to reduce the pressure loss in each unit's circuit.

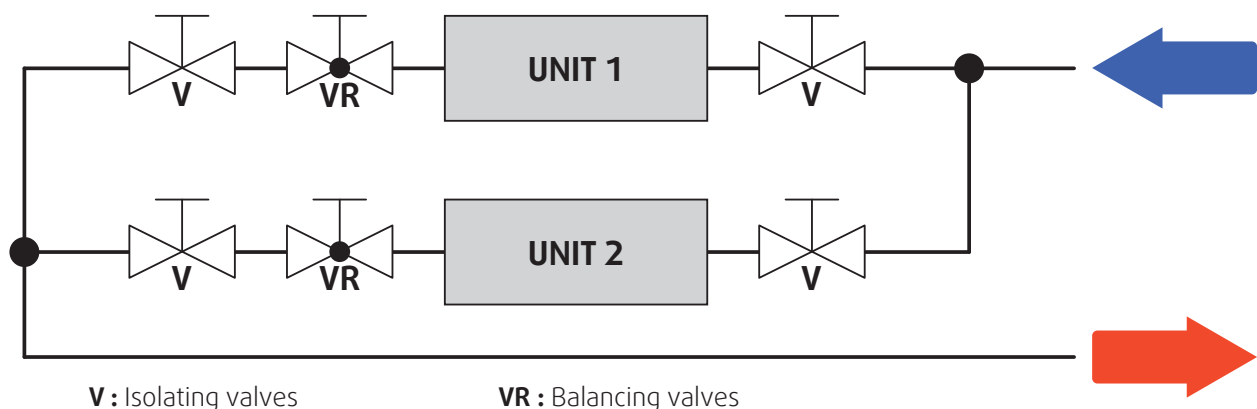

Install a balancing valve on the output pipe to adjust the water flow.



Caution

The water inlets and outlets must be connected as described on the labels affixed near the connections.

When the hydraulic pump option is selected, a safety valve (SS) set to 3bar, (SS) is mounted at the water circuit inlet to prevent overpressure in the circuit. The installer must install a pipe at the safety valve outlet for water evacuation. The "lack of water" pressure switch (WPS), available as an option, is set as follows:

- RANGE: 1 bar DIFF: 0.5 bar

If the pressure in the circuit drops below 0.5 bar, the unit stops. When the pressure rises above 1.5 bar again, the unit restarts.

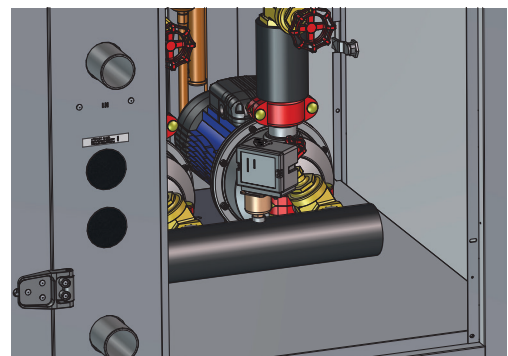

Information

In the case of a **SYSAQUA R32** without a pump, the "lack of water" pressure switch (WPS) must be fitted to the external pump supply pipes and wired to terminals 24 and 25 on the unit.

12. WIRING DIAGRAM AND LEGEND

12.1. WIRING DIAGRAM

SEE APPENDIX

12.2. LEGEND

POL698 | POL965

SE4945

Control and power for models 50 to 60 kW

12.2.1. POWER SUPPLY

Power cable must be connected to the main power supply switch QG (Copper cable is recommended).

The supply is protected at the head by an FFG main fuse holder supplied by the installer. It must be fitted next to the unit. Refer to the § **ELECTRIC SPECIFICATIONS**, page 19

The electrical installation and wiring of this unit must comply with local electrical installation standards.

➤ Three phase 400 V~ 50Hz + Ground :

- On the L1, L2, L3 terminals of the QG section switch
- On the ground screw of the earth cable.

12.2.2. WIRING DIAGRAM KEY DESCRIPTIONS

SEE APPENDIX

12.2.3. RANGE AND SETTINGS OF THERMAL PROTECTION / NOMINAL INTENSITY OF THE CONTACTORS (CLASSE AC3)

MODELS			50	60
KC-1.1	AC	Range	A 17-23	24-32
		Setting	A 22	26
	EC	Range	A 17-23	24-32
		Setting	A 22	26
KC-1.2	AC	Range	A 17-23	17-23
		Setting	A 19	19
	EC/HPF	Range	A 17-23	17-23
		Setting	A 19	19
FTOF-1.1	EC/HPF	Range	A 2.5-4	2.5-4
		Setting	A 4	4
FTWP-0.1	Pump SP	Range	A 4-6.3	4-6.3
		Setting	A 5	5
	Pump HP	Range	A 4-6.3	4-6.3
		Setting	A 5	5
	SP VAR	Setting	A 6.3	6.3
	HP VAR	Setting	A 6.3	6.3

12.3. CRANKCASE HEATER THERMOSTAT ADJUSTMENT RANGE

The crankcase heater thermostat (TEBF-0.1) enables the crankcase heaters to be activated when the compressors are stopped and the outside temperature is below 7 °C (recommended minimum value). That value can be adjusted depending on the installation site.

The manufacturer declines any responsibility and the warranty becomes void if these instructions are not complied with.

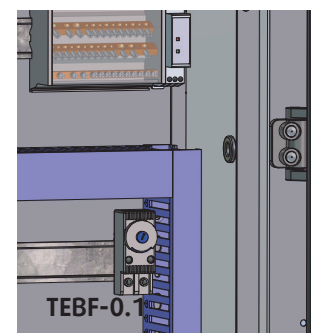

13. ELECTRICAL CONNECTIONS

WARNING



Before carrying out any work on the equipment, make sure that the electrical power supply is disconnected and that there is no possibility of the unit being started inadvertently. Non-compliance with the above instructions can lead to injury or death by electrocution.

The electrical installation must be performed by a fully qualified electrician, and in accordance with local electrical standards and the wiring diagram corresponding to the unit model.

Any modification performed without our prior authorisation may result in the unit's warranty being declared null and void.

The power supply cable section must be sufficient to provide the appropriate voltage to the unit's power supply terminals, both at start-up and under full load operating conditions.

The power supply cable shall be selected in accordance with the following criteria:

1. Power supply cable length.
2. Maximum unit starting current draw – the cables shall supply the appropriate voltage to the unit terminals for starting.
3. Power supply cables' installation mode.
4. Cables' capacity to transport the total system current draw.

The use of fuse to protect the units against short circuits is recommended. The fuse sizes are displayed in the table in § **ELECTRIC SPECIFICATIONS**, page 19

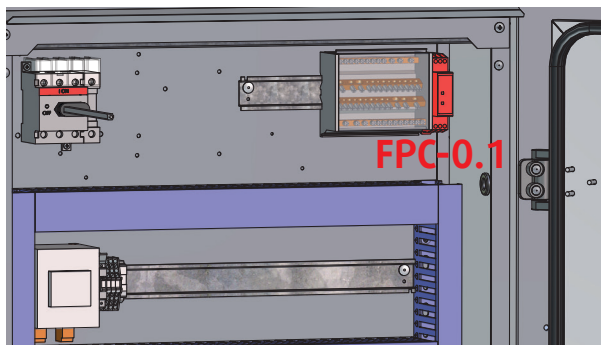

VERY IMPORTANT:

3~400V-50HZ

The outdoor unit is equipped as standard with a phase sequence and cut-out controller located in the electrical box.

THE LED'S INDICATE THE FOLLOWING CONDITIONS:

Green LED = 1

Yellow LED =1

Power ON

The compressor rotation direction is correct.

Green LED = 1

Yellow LED =0

Phase inversion or phase absent (L1)

The compressor and the fans do not start.

Green LED = 0

Yellow LED =0

Phase absent (L2 or L3)

The compressor and the fans do not start.



Caution

Before connecting the supply lines, check that the voltage available is within the limits specified (Refer to the § ELECTRIC SPECIFICATIONS, page 19).

Voltage differences between each phase do not have to exceed 2 %.

If the unbalance is unacceptable, call the distribution company to have this anomaly corrected.



Caution

Supplying the unit with a line with an unbalance exceeding the acceptable value results in cancelling the warranty.



Caution

Correction of the excessive centralized power factor (>0.95) may generate transient phenomena dangerous for the motors and contactors of the unit during the start and stop phases. Check instant voltages during these phases.

These units are equipped with a local switch used as general terminal board.

13.1. UNIT POWER SUPPLY

The supply cables of the units must be routed up to the section switch through the grommets present at the base of the electrical unit.

To ensure proper contact, fit the end pieces adapted to the cross-section of the connecting cable.

Maximum cross-section of the power supply cables (for copper cable only):

- SYSAQUA R32 50 – 60: 35 mm²

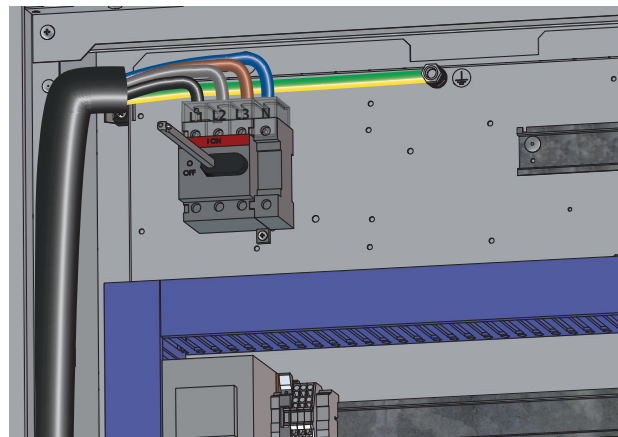
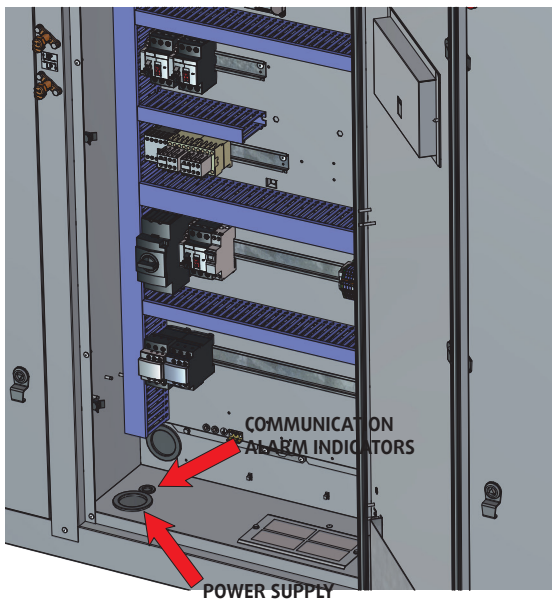
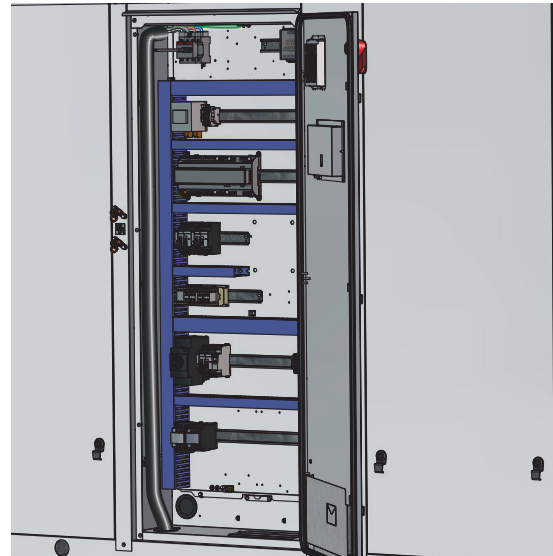

THE ILLUSTRATION SHOWS THE WIRING OF 3N-400V-50HZ



Information

The wire grommets on the front panels of units must be replaced with cable glands for any cable transits to ensure proper sealing.

13.2. OPTIONS ALL SEASONS AND VARIABLE FLOW PUMP

If you have an IT (ungrounded) system or corner-grounded TN system, disconnect the internal EMC filter by removing the EMC screw.

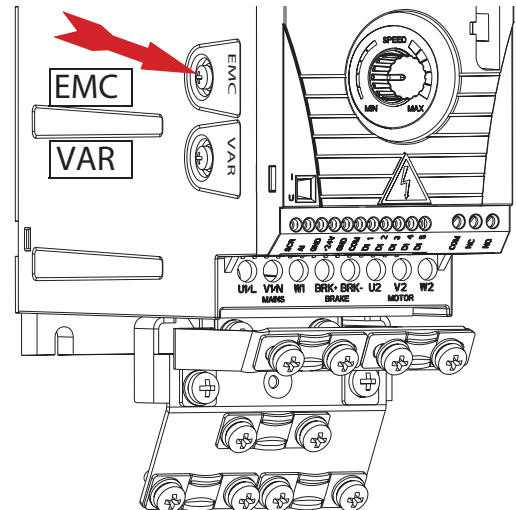

Caution

Disconnect the internal EMC filter when installing the drive on an IT system (an ungrounded power system or a high-resistance-grounded [over 30ohms] power system), otherwise the system will be connected to ground potential through the EMC filter capacitors. This may cause danger or damage the drive.

Disconnect the internal EMC filter when installing the drive on a corner-grounded TN system, otherwise the drive will be damaged.

13.3. ELECTRIC HEATING OPTION

The power cable for the electric heating must be routed to the disconnecting switch through the cable glands at the bottom of the unit.

To ensure proper contact, fit the end pieces adapted to the cross-section of the connecting cable.

Maximum cross-section of the power supply cables:

- 12kW 10mm²
- 24kW / 36kW 35mm²

copper cable only

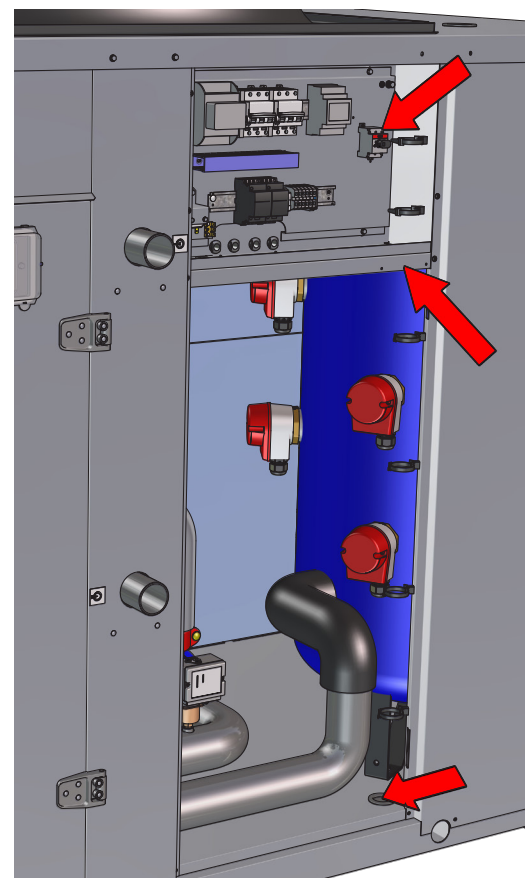

13.4. ALARM INDICATORS

The **SYSAQUA R32** control system has a dedicated alarm indicator. This information is available via a dry contact (Normally Closed) by connecting to the unit's terminals 3 and 4.



Caution

The unit must only be rendered accessible for maintenance if the client cables connected to terminals 3 and 4 are locked out/tagged out (disconnected or rendered inoperative upstream of the unit).

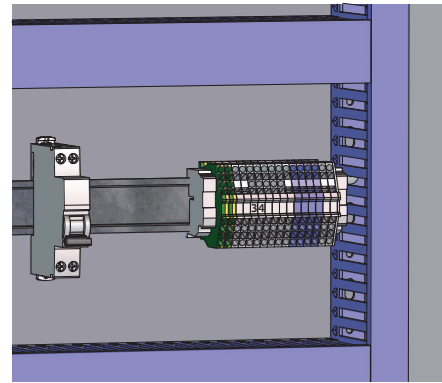

13.5. REMOTE CONTROL

The **SYSAQUA R32** has two remote controls operating via dry contacts (not supplied):

- ON/OFF function connected to terminals D1 and M on the controller
- operating mode selection (SWS) connected to terminals D2 and M on the controller

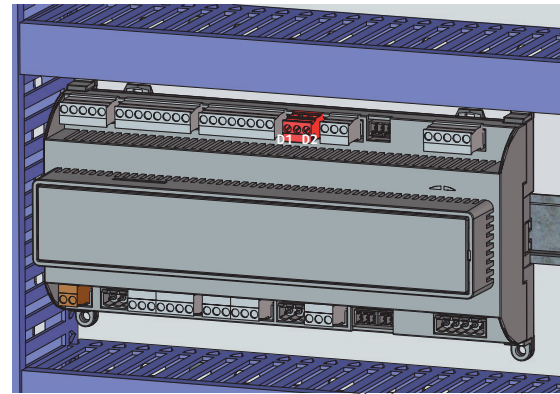
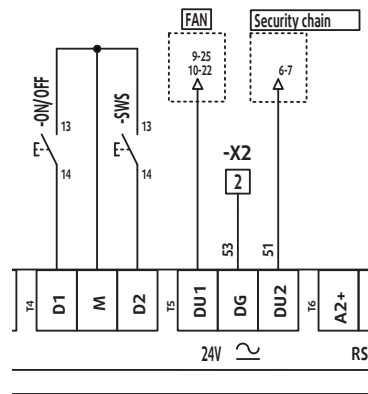

13.6. COMMUNICATION

The **SYSAQUA R32** has four different communication protocols:

- Modbus TCP/IP
- BACNet IP
- Modbus RTU
- BACNet MS/TP

Modbus TCP/IP or BACNet IP communications are via an RJ45 connector and Ethernet type connector.

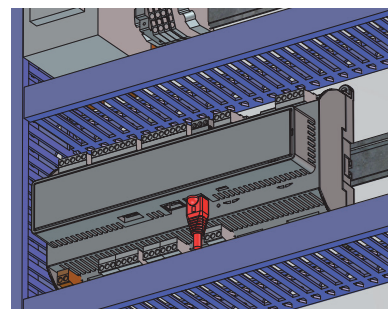

Modbus RTU or BACnet MS/TP communications are via the RS485 connection on the controller (terminals A2 and B2) and a BUS type cable (1 twisted pair, shielded) with a 0.22 mm² cross-section.

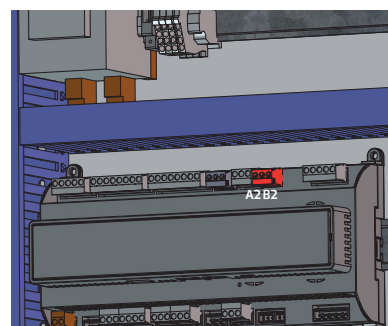

14. REGULATION

SYSAQUA R32 units are fitted with an electronic control system. It provides the command, control and alarm functions.

14.1. ORDER OF PRIORITY FOR CONTROL SYSTEMS

The **SYSAQUA R32** can be controlled by various interfaces and systems. The order of priority for each drive system is as follows:

1. The HMI: the commands are given by the user directly on the unit (integrated display) or remotely (remote display)
2. Digital inputs: the client can transmit commands electro-mechanically over 2 dry contacts:
 - ✓ Input D1: ON/OFF
 - ✓ Input D2: configurable
3. The BMS : the remote supervision transmits it commands according to the communication protocols
4. Timing programming: this scheduling is integrated in the regulator



14.2. USER INTERFACE

This terminal has a liquid crystal display and has 6 buttons.

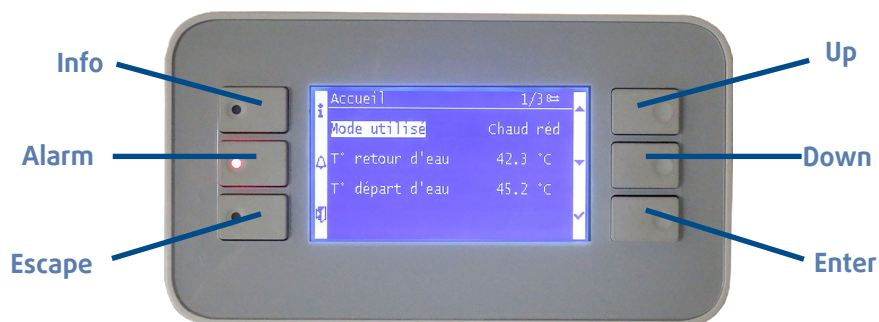

14.2.1. KEYPAD

INFO	From any screen, this button returns the user to the main menu or home screen and, like the ESCAPE button, invalidates a current modification.
ALARM	When pressing the alarm button (the red LED flashes if an alarm is active), the alarm management menu is displayed. (see § alarms)
ESCAPE	Returns to the previous level in the menu tree. Pressing this button during modification invalidates the change being made and returns the user to the previous menu. This function is very important if a setting is inadvertently modified.
UP/DOWN	These buttons have two functions. <ol style="list-style-type: none"> 1. In a menu, they are used to move up and down the list of possible options. 2. They can change the value of a setting when it has been selected.
ENTER	This button has three functions <ol style="list-style-type: none"> 1. It is used to access a submenu 2. Activate the modification of a setting 3. Validate the modification of a setting

14.2.2. HOME PAGE

The home page is used quickly display the state of the unit:

- Current mode
- Water inlet temperature (RWT)
- Water outlet temperature (LWT)

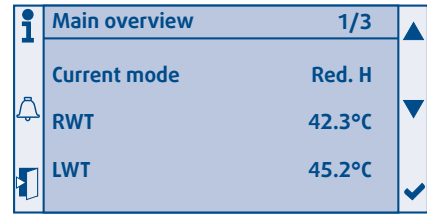

14.2.3. MAIN MENU

Pressing the "Info" button displays this screen directly.

The authorized menus are displayed according to the access level selected:



Access level	Final user	Installer	Maintenance
"Access" menu	✓	✓	✓
"Status" menu	✓	✓	✓
"Commissioning" menu	✗	✓	✓
"Service" menu	✗	✗	✓
"Alarms" menu	✓	✓	✓

14.2.4. MENUS

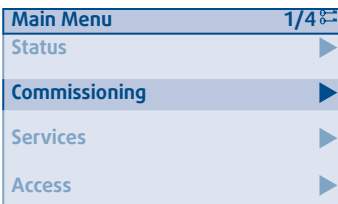



The display has several menus. The "Status" menu is freely accessible. The other "Installation" and "Maintenance" menus can be displayed and accessed according to the access level.

To change the access level, go to the "Access" menu and enter the password corresponding to the level.

The first line of all the screens integrates the following information:

- Screen title
- Number of the active line/number of lines of the menu
- Access level

- ✓ Final user 
- ✓ Installer 
- ✓ Maintenance 

14.3. INITIAL SETTINGS

Open the electrical box and check that all circuit breakers are open except for **FTC**.

Before starting up the **SYSAQUA R32** for the first time, the "Installation" menu must be configured.

14.3.1. TIME SETTINGS



Caution

If the date and time are not set, the unit will function in degraded mode or may not even be able to start.

Start by configuring the date and time.

To do so, switch to the "Installer" or "Maintenance" profile in the "Installation" section. The first line of the menu is used to set the date and time.

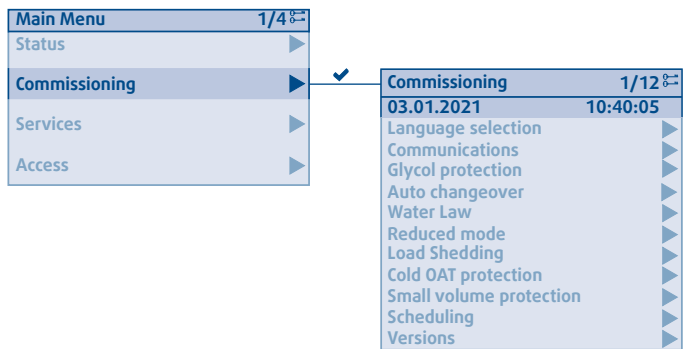

The date and time line will appear as highlighted.

Press the "Enter" button ✓ to activate the change in date.

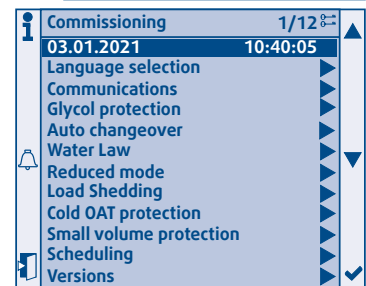

The ▲ and ▼ buttons are used to change the highlighted setting.

Press once on the ✓ button to approve the defined value and move on to the next setting.



Information

Power outage lasting longer than 8h will lead to a loss of the time setting. It is important to set the unit back to the right time after such an event.

14.3.2. LANGUAGE SETTINGS

Select the languages required according to the application.

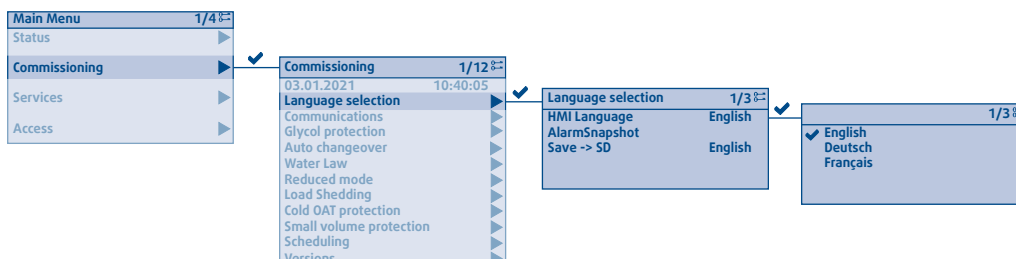

14.3.3. DEFINING THE GLYCOL RATE

Define the type and glycol content present in the installation water circuit.

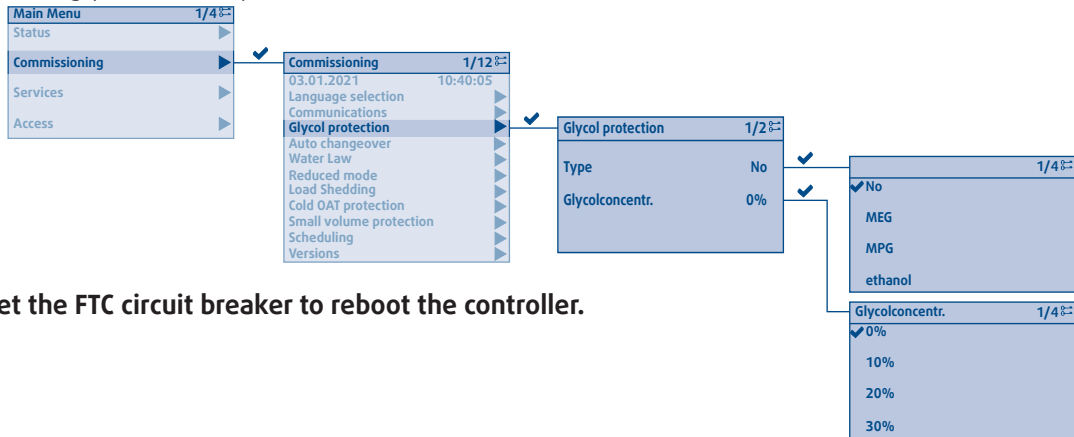

Open then reset the FTC circuit breaker to reboot the controller.

14.4. LAUNCHING THE SYSAQUA R32 SYSTEM

14.4.1. CONFIGURING INPUT D1

During installation, an on/off switch can be connected remotely onto the D1 input.

This input's behavior must be defined.

Factory configuration :
No switch and NO setting

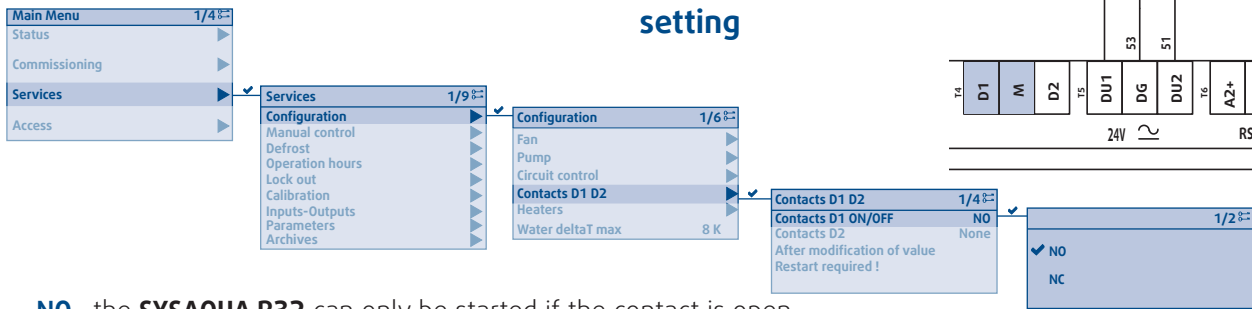

NO : the **SYSAQUA R32** can only be started if the contact is open.

With NC switch and NC setting

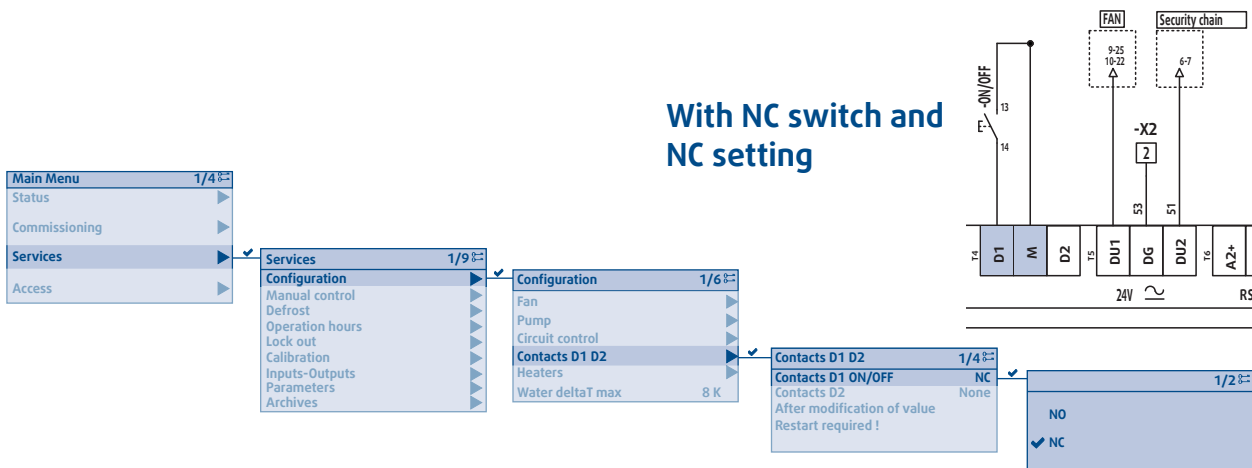

NC : the **SYSAQUA R32** can only be started if the contact is closed.

Configuration	Contact open	Contact closed
Normally Open NO	Operation order (ON)	Stop order
Normally Closed NC	Stop order	Operation order (ON)



Caution

If the settings are changed, open then reset the FTC circuit breaker to reboot the controller.

14.4.2. CONFIGURING INPUT D2

During installation, a switch can be connected onto the D2 digital input.

The operating mode defined for this input takes priority over all control systems such as the HML, BMS or calendar.

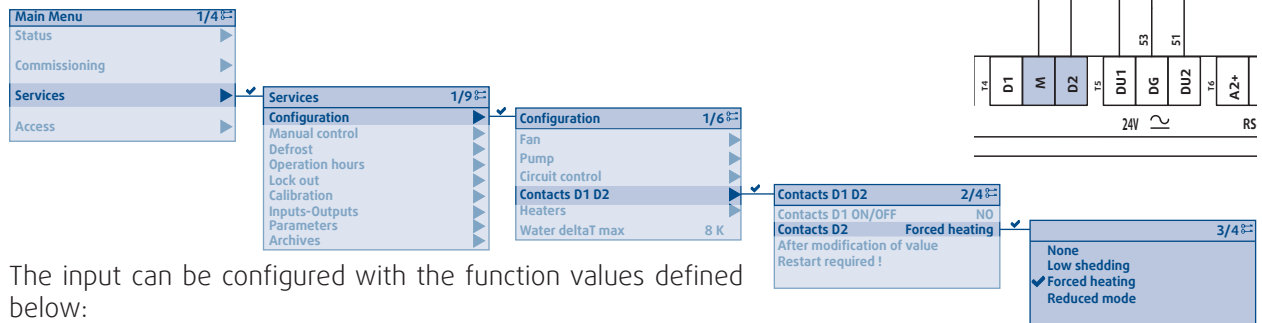
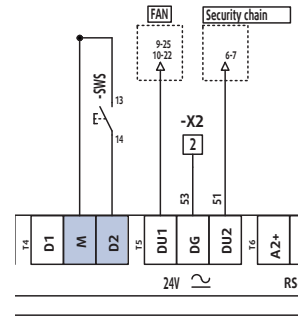

The input can be configured with the function values defined below:

- None
- Load shedding
- Forced Heating
- Reduced mode

Further information regarding this contact's configuration can be found in the user manual.

14.4.3. HEAT/COOL SELECTION

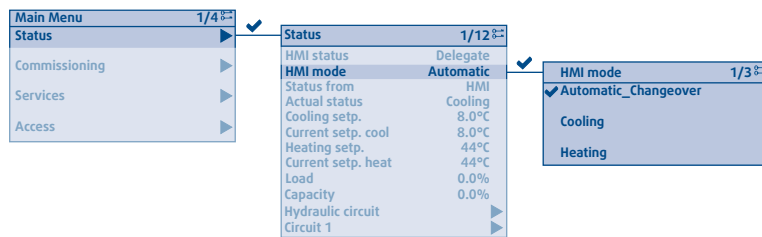

The operating mode can be chosen in the "HMI mode":

- **Automatic_Changeover:** delegated to the BMS/Auto-change-over (refer to the UM)
- **Cooling:** request for cool mode
- **Heating:** request for heat mode

Information

Selection of the heat/cool mode is only possible in reversible units. This menu does not exist in the "cool only" versions.

The "Actual status" line states which element requested the current mode:

- **Contact: D2** configurable digital input
- **HMI:** user interface
- **BMS**
- **Schedule.**

Status 1/12	
HMI status	Delegate
HMI mode	Automatic
Status from	HMI
Actual status	Cooling
Cooling setp.	8.0°C
Current setp. cool	8.0°C
Heating setp.	44°C
Current setp. heat	44°C
Load	0.0%
Capacity	0.0%
Hydraulic circuit	
Circuit 1	

14.4.4. SELECTING THE OPERATING MODE

To launch the unit, the user must select the desired mode in the menu:

- **Delegate** : the current mode is determined by the BMS or by default by the calendar (refer to the user manual)
- **Off** : Unit is stopped
- **On** : System is launched
- **Reduced** : Refer to the § **REDUCED MODE**, page 44
- **Load shedding** : Refer to the § **LIMITED CAPACITY**, page 44

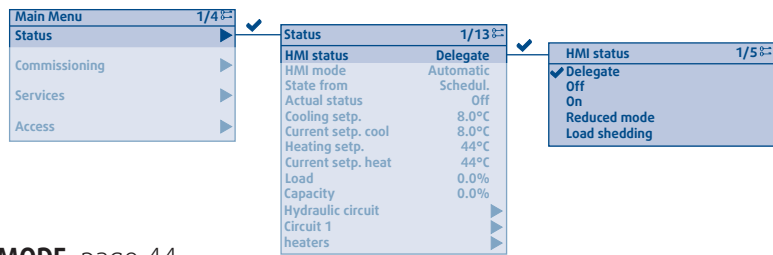

The "Status from" line states which element requested the current status:

- **Cont.off**: on/off digital input
- **Cont.ext: D2** configurable digital input (in "Load shedding", " Forced Heating" or "Reduced mode")
- **HMI**: User interface
- **BMS**
- **Schedule**

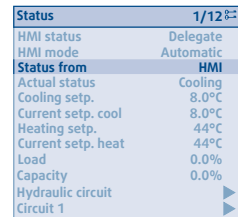

14.4.5. USER TEMPERATURE SETPOINTS AND ACTUAL SETPOINTS

In the Status menu, the user can set start or return temperature setpoints, according to the control mode selected:

- **Cooling setp**: temperature setpoint for the cool mode
- **Heating setp**: temperature setpoint for the heat mode

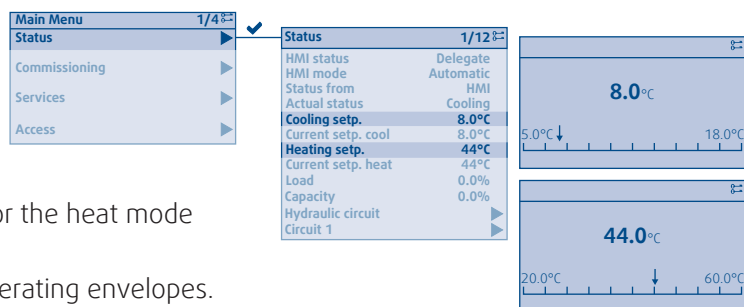

These setpoints are limited to the unit's operating envelopes.

- **Current setp. cool**: current setpoint for cooling mode
- **Current setp. heat**: current setpoint for heating mode

Adjustment by activating the "Water law" or "Reduced mode" options will cause the setpoints to vary automatically according to external conditions.

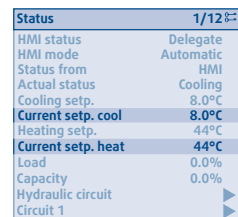

Regardless of the adjustment, the resulting setpoint is restricted to the operating limits to protect the unit. Actual heating and cooling setpoints match the values utilized in real time for optimal operation of units

14.4.6. WATER LAW

The configuration of the different water law settings dynamically matches the setpoint according to the outside temperature.

The different parameters below for the water law can be set in the installation menu and by a GTC.

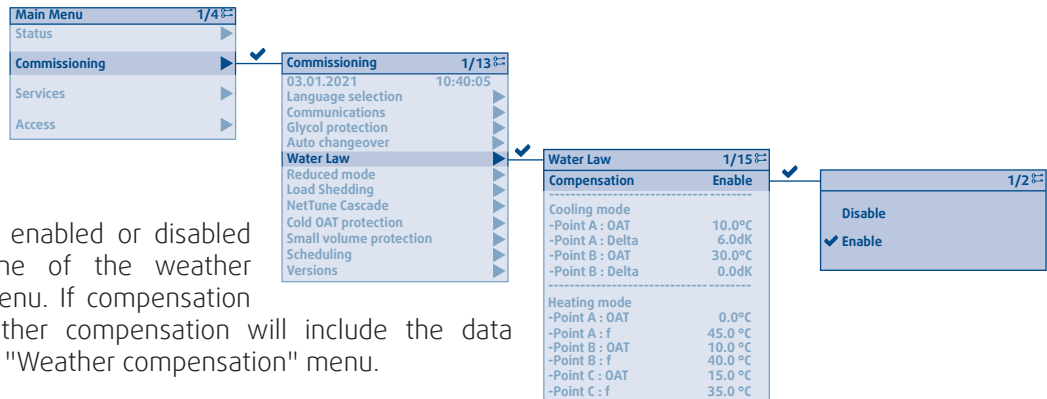

Compensation is enabled or disabled via the first line of the weather compensation menu. If compensation is enabled, weather compensation will include the data configured in the "Weather compensation" menu.



Caution

If the automatic heat/cool changeover mode is selected, weather compensation is enabled by default. The default weather compensation values are applied without using the weather compensation menu settings.

14.4.6.1. COOL MODE

The water law introduces correction Δ which depends on the OAT outside temperature:

➤ water law setpoint = cool mode temperature setpoint + Δ (OAT)

Correction Δ is restricted between 0 and 8K. It is defined by points A and B in the graph below. The values indicated are factory values.

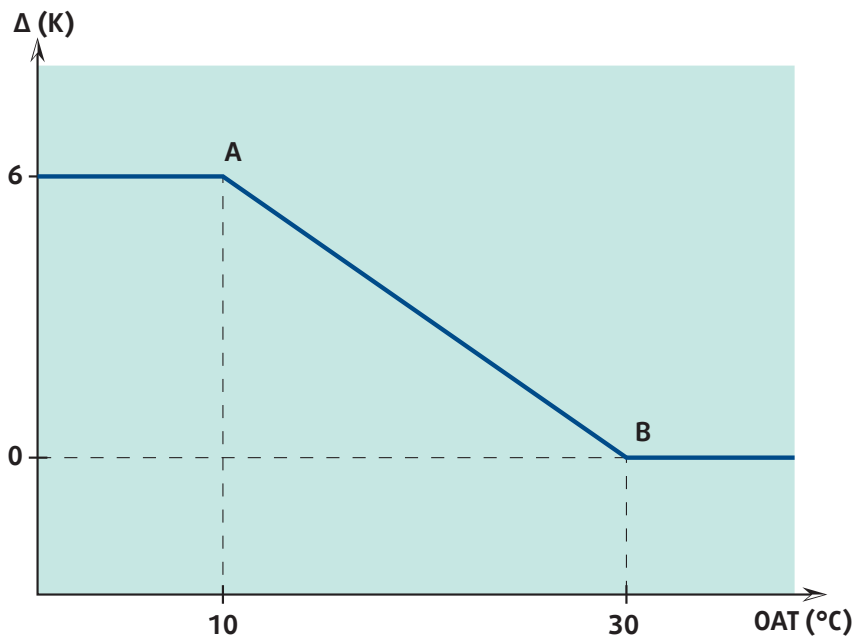

Water Law		1/15
Compensation	Enable	
Cooling mode		
-Point A : OAT	10.0°C	
-Point A : Delta	6.0dK	
-Point B : OAT	30.0°C	
-Point B : Delta	0.0dK	
Heating mode		
-Point A : OAT	0.0°C	
-Point A : f	45.0 °C	
-Point B : OAT	10.0 °C	
-Point B : f	40.0 °C	
-Point C : OAT	15.0 °C	
-Point C : f	35.0 °C	

Points	Coordinates	unit	Values		
			Min.	Max.	Default
A	OAT	°C	10	$OAT_A < OAT_B$ $OAT_A \leq 30$	10
	Δ	K	Δ_B	8	6
B	OAT	°C	$OAT_B > OAT_A$ $OAT_B \geq 20$	36	30
	Δ	K	0	Δ_A	0

14.4.6.2. HEAT MODE

The water law replaces the heat mode setpoint with the f function of the OAT outside temperature:

➤ water law setpoint = f(OAT)

Function f is restricted between 20 and 60°C. It is defined by points A, B and C in the graph below. The values indicated are factory values.

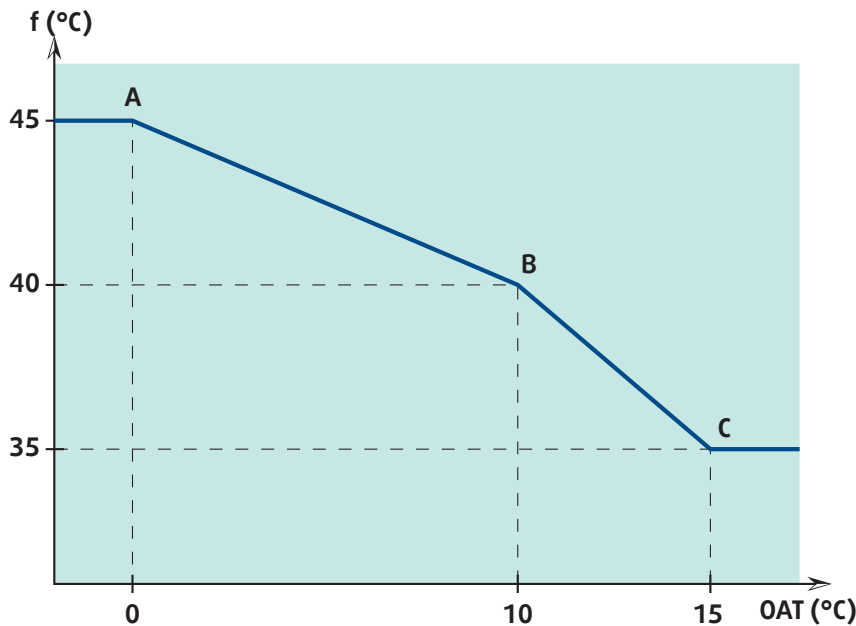

Water Law	1/15
Compensation	Enable
Cooling mode	
-Point A : OAT	10.0°C
-Point A : Delta	6.0dK
-Point B : OAT	30.0°C
-Point B : Delta	0.0dK
Heating mode	
-Point A : OAT	0.0°C
-Point A : f	45.0 °C
-Point B : OAT	10.0 °C
-Point B : f	40.0 °C
-Point C : OAT	15.0 °C
-Point C : f	35.0 °C

Points	Coordinates	unit	Values		
			Min.	Max.	Default
A	OAT	°C	-20	OAT _B	0
	f	°C	f _B	60	45
B	OAT	°C	OAT _A	OAT _C	10
	f	°C	f _C	f _A	40
CC	OAT	°C	OAT _B	50	15
	f	°C	20	f _B	35

14.4.7. FIXED SPEED PUMP

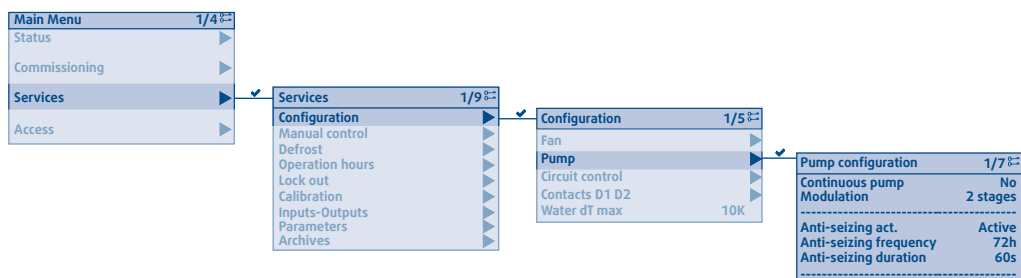

The fixed speed pump installed as standard is activated when a load request arises.

The constant speed setting of the pump allows the circulation of water to be maintained even when there is no load request.



Caution

If the settings are changed, open then reset the FTC circuit breaker to reboot the controller.

14.4.8. "VARIABLE PRIMARY FLOW" OPTION

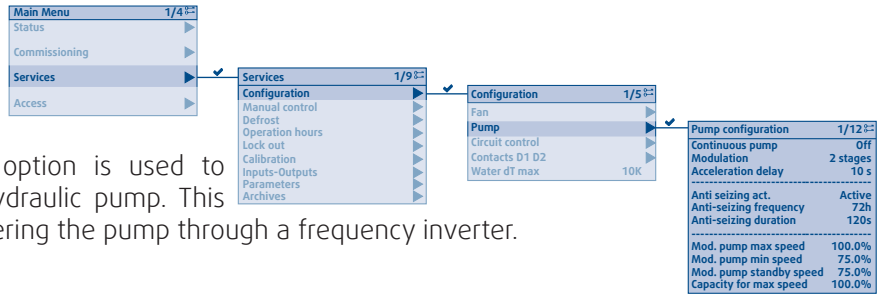

The "Variable Primary Flow" option is used to modulate the power of the hydraulic pump. This modulation is obtained by powering the pump through a frequency inverter.



Caution

The minimum frequency of the pump must not be less than the manufacturer's recommendations (e.g. 45Hz) and must ensure a sufficient rate for the unit (Refer to the § PHYSICAL CHARACTERISTICS - SYSAQUA R32 L - STD version, page 14).

14.4.8.1. V2 MODE - DOUBLE SPEED

As soon as the load to which the unit must respond is higher than the 1st stage of thermodynamic capacity, the pump operates at maximum speed. That speed is adjustable and must be determined during commissioning to adjust the power of the pump to the load losses of the installation.

When the load is below the 1st stage of thermodynamic capacity, the pump runs at standby speed to limit the consumption of electricity.



Default	setting	min	max
Mod. pump max speed	80%	0%	100%
Mod. pump standby speed	60%	0%	100%

14.4.8.2. VP MODE - CONSTANT OUTPUT PRESSURE

The frequency inverter controls the pump's speed to maintain an even water pressure at the output of the unit, regardless of the number of operating terminals.



Caution

The hydraulic facility must include a system that retains the required minimum water pressure when the terminals' two-way valves are shut.

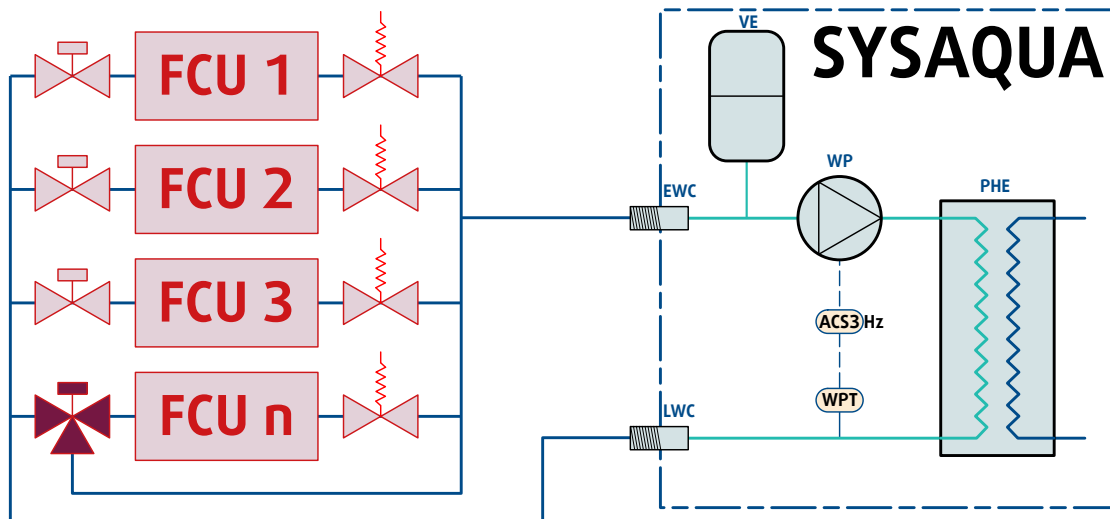

Installation of one or more three-way valves on the facility to maintain the minimum required pressure.

It is necessary to determine the pressure setting to be maintained in the system then set the frequency inverter according to this pressure value.

14.4.8.2.1. DETERMINATION OF THE PRESSURE SETTING

The frequency inverter **ACS3** displays the reading via the pressure transducer **WPT**.

1. Set all units in demand to open all the valves (load = 100%).
2. Check that the output is in line with **SYSAQUA R32** requirements.
3. Read the pressure value from the transducer (example: 3.5 bar).

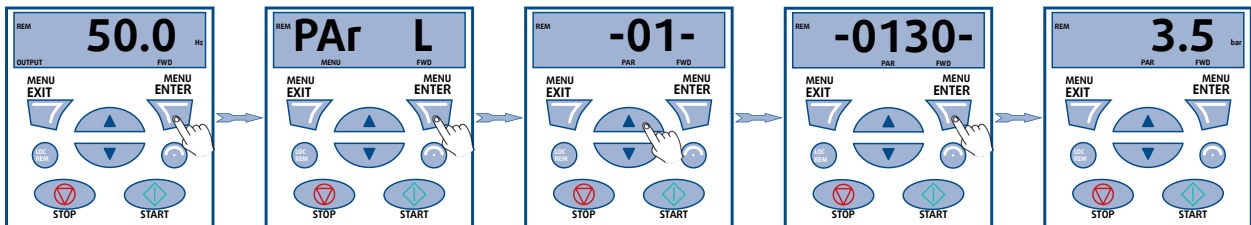

14.4.8.2.2. SETTING THE PRESSURE SETTING

The pressure setting is set in two stages:

1. Access parameter **4006** and set it to **22** to display units in bar.
2. Access parameter **4011** then set the required pressure setting (example 3.5 bar).

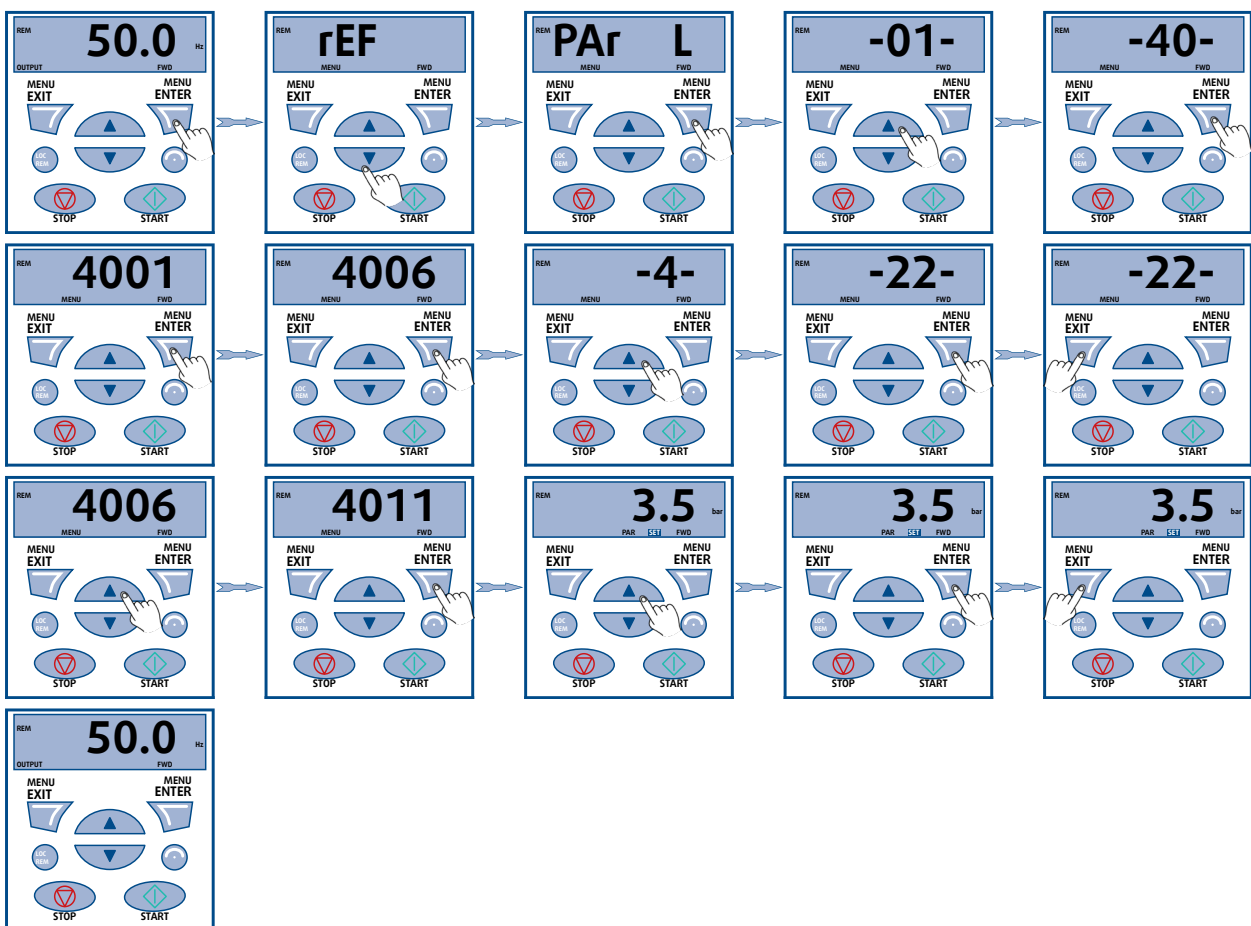

When the pressure setting is set, check that the system is operational in the following conditions:

- when in partial load, the pressure is constant.
- when at zero load (all units off), check that the inverter frequency has dropped to the minimum value and that no water pressure alarm is triggered

14.4.9. REDUCED MODE

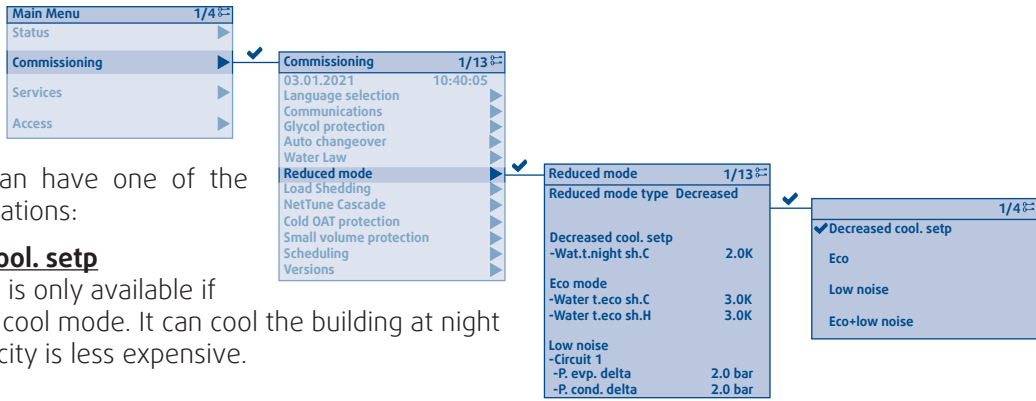

Reduced mode can have one of the following configurations:

- **Decreased cool. setp**
This function is only available if the unit is in cool mode. It can cool the building at night when electricity is less expensive.
- **Eco**
Heat and cool setpoints are respectively lowered and raised to reduce the unit's electrical consumption.
- **Low noise**
In cool mode, the condensation pressure setpoint is increased to reduce the noise generated by the ventilators.
- **Eco + Low noise**

The "reduced mode" mode activation can be triggered in the following ways:

- directly on the **SYSAQUA R32** via the user interface
- communication network (Modbus/Bacnet/Cloud)
- external dry contact D2 if entry configured.

14.4.10. LIMITED CAPACITY

Load reduction mode can be used to limit thermodynamic capacity temporarily. Electrical consumption of the **SYSAQUA R32** will thus be reduced to prevent exceeding the installation site's electrical power capacity.

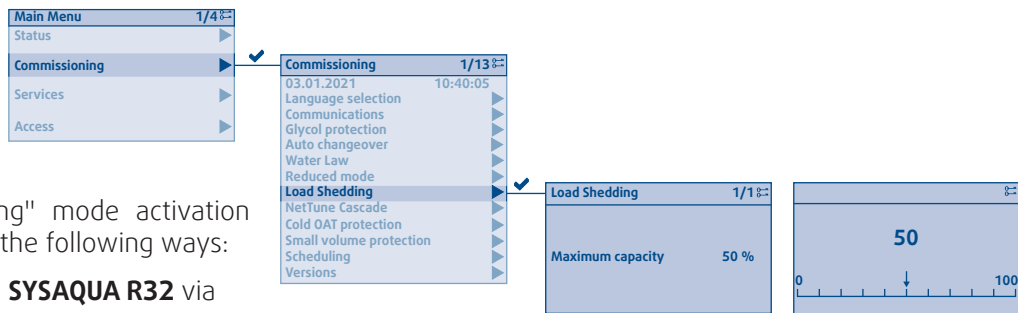

The "Load Shedding" mode activation can be triggered in the following ways:

- directly on the **SYSAQUA R32** via the user interface
- communication network (Modbus/Bacnet/Cloud)
- external dry contact **D2** if entry configured.

Examples for maximum capacity adjustment:

- between 0% and 49% the unit is stopped
- between 50% and 99% the unit is limited to a single compressor

14.5. ALARMS

If no alarm is active, pressing the "Alarm" button takes you to the alarm history

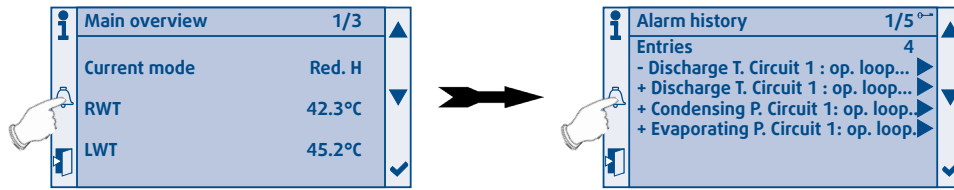

If at least one alarm or event is active, the alarm button flashes. Pressing the "alarm" button, will display successively :

- The last active alarm
- The list of active alarms
- The alarms history
- The alarms menu and event

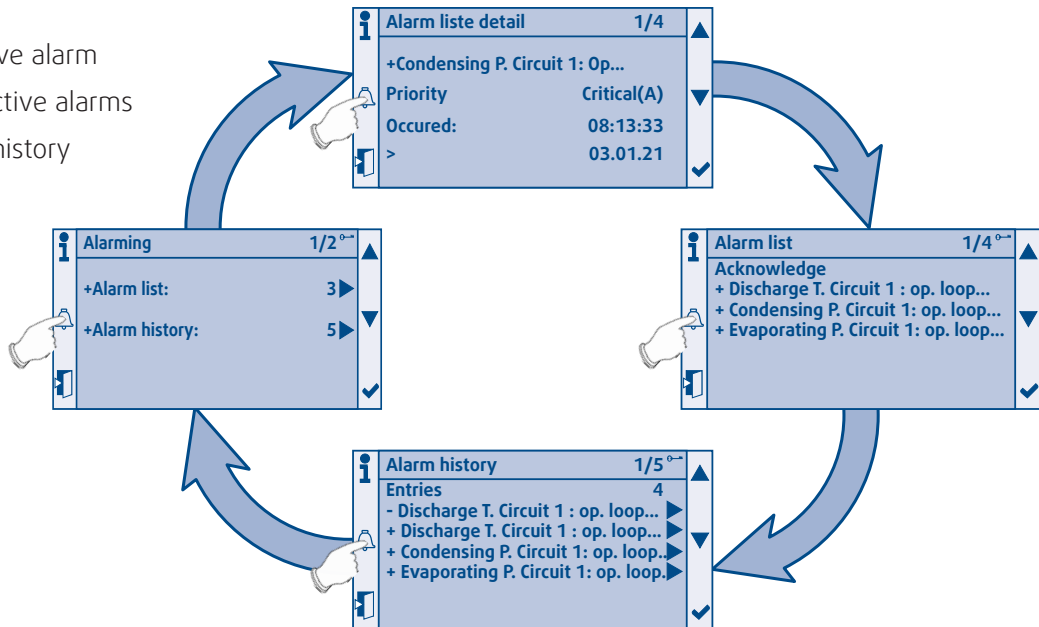

14.5.1. ALARM DETAILS

This page is displayed :

- Details of the last active alarm
- If you request the details of an alarm in the list of active alarms
- If you request the details of an alarm in the alarms history

Alarm liste detail	1/4
+Condensing P. Circuit 1: Op...	
Priority	Critical(A)
Occured:	08:13:33
>	03.01.21

- ➔ Alarm designation
- ➔ Alarm critical level
- ➔ Date and time of the alarm

14.5.2. THE LIST OF ACTIVE ALARMS

The list of active alarms allows visualization of current alarms

The first line shows the number of active alarms (3 in the example below)

Alarm list	1/4
Acknowledge	
+ Discharge T. Circuit 1 : op. loop...	
+ Condensing P. Circuit 1: op. loop...	
+ Evaporating P. Circuit 1: op. loop...	

- ➔ Number of active alarms / deletion of alarms
- ➔ Alarm 1 active
- ➔ Alarm 2 active

You can access the alarm details by selecting an alarm and pressing the "Enter" button .

Alarm list	1/4
Acknowledge	
+ Discharge T. Circuit 1 : op. loop...	
+ Condensing P. Circuit 1: op. loop...	
+ Evaporating P. Circuit 1: op. loop...	

Alarm liste detail	1/4
+Condensing P. Circuit 1: Op...	
Priority	Critical(A)
Occured:	08:13:33
>	03.01.21

With installation or maintenance level access, you can acknowledge active blocking alarms. To do this select delete, confirm and select "Execute". Only the alarms that are no longer active will be deleted from the list.

Alarm list	1/4
Acknowledge	
+ Discharge T. Circuit 1 : op. loop...	
+ Condensing P. Circuit 1: op. loop...	
+ Evaporating P. Circuit 1: op. loop...	

	1/2
<input checked="" type="checkbox"/> Execute	

14.5.3. ALARMS HISTORY

This history reports the 150 most recent activation or deactivation of alarms:

- Activation of an alarm will be indicated by a "+"
- Deactivation of an alarm will be indicated by a "-"

Alarm deactivated ←

Alarm 1 activated ←

Alarm 2 activated ←

Alarm history	1/5
Entries	4
- Discharge T. Circuit 1 : op. loop...	▶
+ Discharge T. Circuit 1 : op. loop...	▶
+ Condensing P. Circuit 1: op. loop...	▶
+ Evaporating P. Circuit 1: op. loop...	▶

For the activation and deactivation time of an alarm, select the alarm and press the "enter" button ✓.

14.6. SCHEDULE

The first line displayed shows the current mode at the level of time programming.

Main Menu	1/4
Status	▶
Commissioning	▶ ✓
Services	▶
Access	▶

Commissioning	1/13
03.01.2021 10:40:05	
Language selection	▶
Communications	▶
Glycol protection	▶
Auto changeover	▶
Water Law	▶
Reduced mode	▶
Load Shedding	▶
NetTune Cascade	▶
Cold OAT protection	▶
Small volume protection	▶
Scheduling	▶ ✓
Versions	▶

Schedule	1/10
Monday	On
Copy schedule	Off
Tuesday	Mo to
Wednesday	On
Thursday	On
Friday	On
Saturday	Off
Sunday	Off
Exception	Off

Monday	1/12
1	00:00
Value 1	Off
Time	07:00
Value 2	On
Time 3	11:00
Value 3	Load Shedding
Time 4	14:00
Value 4	On
Time 5	22:00
Value 5	Off
Time 6	*:*
Value 6	Off

Off	1/4
<input checked="" type="checkbox"/> Off	
On	
Reduced mode	
Load Shedding	

In the Monday submenu, 6 operating intervals can be selected. For each time, select the mode at which the unit must operate:

- Off
- On
- Reduced mode
- Load shedding

To deactivate an operating interval, configure the corresponding time as follows: *:*

The "Copy calendar" line copies the configuration made on Monday from Tuesday to Friday or from Tuesday to Sunday.

The configuration of the weekdays can also be changed separately.

⚠ **Caution**

To ensure activation of the mode indicated in the calendar, the unit must operate in "Delegate" mode.

Main Menu	1/4
Status	▶ ✓
Commissioning	▶
Services	▶
Access	▶

Status	1/12
HMI status	Delegate
HMI mode	Automatic
Status from	HMI
Actual status	Cooling
Cooling setp.	8.0°C
Current setp. cool	8.0°C
Heating setp.	44°C
Current setp. heat	44°C
Load	0.0%
Capacity	0.0%
Hydraulic circuit	▶
Circuit 1	▶

HMI status	1/5
Delegate	
Off	
On	
<input checked="" type="checkbox"/> Reduced mode	
Load shedding	

15. COMMISSIONING



Information

THE COMMISSIONING FORM AVAILABLE IN THE ANNEX MUST BE COMPLETED, HANDED TO THE OPERATOR AND SENT TO THE MANUFACTURER AS A PRIOR CONDITION FOR THE WARRANTY TO APPLY.



Caution

When performing startup and service, thorough safety precautions shall always be taken.

Only a skilled person who is trained in the handling of refrigerating systems (as per standard EN13313) and flammable fluids (certified and with proof of relevant training) may carry out this work.

15.1. PRE-START CHECK LIST

Before commissioning the system, you must carry out a certain number of installation checks to ensure that the appliance will operate in the best possible conditions. The following list of checks is not exhaustive and only serves as a minimum reference guide.

1. Make sure that no source of ignition is present in the work area
2. Make sure that the work area is adequately ventilated
3. Make sure that suitable fire extinguishing equipment is available and within reach
4. Make sure that the concentration of R32 in the atmosphere of the work area is continuously controlled in order to be able to warn people of a potentially hazardous situation.
5. Check that the equipment installed, including options, matches the order
6. Check that the oil heating resistors have been energized for at least 12 hours.

15.1.1. VISUAL CHECK

1. Check the lack of debris or cardboard in the unit.
2. Check free clearances around the unit :
 - ✓ exchanger air intake
 - ✓ exchanger air outlet
 - ✓ access or maintenance work.
3. Unit mounted as specified.
4. Check that the unit is level and that condensates drain freely away from the unit (for Heat pump units).
5. Check that there is no possibility of blown air being recycled through the fans due to wind exposure.
6. In arduous climates (sub-zero temperature, snow, high humidity), check that the appliance is raised 10 cm off ground.
7. For loose or missing bolts or screws.
8. For refrigerant leaks in connections and components.

15.1.2. ELECTRICAL CHECK

1. Electrical installation has been carried out according to unit wiring diagram and the Supply Authority Regulations in effect.
2. Size fuses or circuit breaker has been installed at the main switchboard.
3. Supply voltages as specified on unit wiring diagram.
4. **Check that all of the appliance's electrical connections have been tightened.**
5. Check that the electric motors are planned for the network supply voltage.
6. The cables and wires are clear of or protected from pipework and sharp edges.
7. Check the electrical grounding of the appliance.
8. Check that the frequency inverters are consistent with the neutral point treatment of the unit (Refer to the § **OPTIONS ALL SEASONS AND VARIABLE FLOW PUMP**, page 31)

15.1.3. HYDRAULIC CHECK

1. Check that the external water circuit components (pumps, user equipment, filters, expansion tank and reservoir if supplied) have been correctly installed in accordance with the manufacturer's recommendations and that the water inlet and outlet connections are correct.
2. Check that the water quality complies with the indicated standards (Refer to the § **WATER QUALITY**, page 26).
3. Check that draining caps have been properly closed.
4. Check that the air vent in the unit has been opened.
5. **Check the presence, direction and position of the water filter upstream of the appliance (mailles \leq 800 μ m).**
6. Check the presence and position of the stop valves to isolate the unit during maintenance periods.
7. Check that the hydraulic circuit is filled correctly and that the fluid flows freely without any signs of leaks or air bubbles. When glycol anti-freeze is used, check that the concentration level is correct.
8. Check that the pump liners are not stuck. The shaft of the motor must turn freely "by hand". If necessary, free up the shaft using a tool.
9. Check the direction of rotation of the pump and leave the fluid to circulate for at least 12 hours for each pump. Then clean the pump inlet water filter.
10. Adjust the water flow in order to comply with the specifications.

15.1.4. REFRIGERATION CHECK

1. Leak test of the refrigeration circuit at the unions and on the various parts. The desired result is 5g/year maximum
2. Check that the fluid indicator is green (set by the factory) indicating absence of humidity.



Caution

The refrigeration circuit is equipped with a IV isolating valve between the plate exchanger and the compressor.

This valve used during the assembly process is open and MUST NOT BE CLOSED UNDER ANY CIRCUMSTANCES DURING OPERATION.

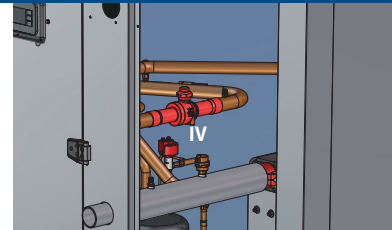

15.2. UNIT START-UP

15.2.1. PHASE ROTATION PROTECTION

If the phase of the power supply is not correct, the phase rotation protection device will prevent the machine from starting (Refer to the § **ELECTRICAL CONNECTIONS**, page 29).

If phase rotation is correct, close all circuit breakers.

15.2.2. FIRST START-UP

When starting up the unit, it is necessary to first energize the compressor casing resistors to evaporate the fluid and oil. The resistors are activated when the unit is switched on (including in standby mode). The controller will prevent start-up if the system is not ready.



Information

The panel on the safety fan side must be present to prevent the machine performing a safety shutdown (checking of ΔP of fan MV)



Information

Every time the **SYSAQUA R32** is powered up, a 3-minute safety cycle runs to check the gas detection board is working correctly. During that cycle, the extractor fan (MV) is tested and the **SYSAQUA R32** cannot start up. The RC Card alert is displayed. At the end of the checking cycle the alarm is canceled automatically and the thermodynamic cycle can start.

Depending on the time of year and the customer requirement:

1. Configure hot/cold mode (Refer to the § **HEAT/COOL SELECTION**, page 37)
2. Start up the unit in manual mode: ON (Refer to the § **SELECTING THE OPERATING MODE**, page 38).

15.2.3. OPERATING CHECK LIST

1. Check for any unusual noises or vibration in the running components.
2. Leak check of the refrigeration circuit in operation. The desired result is 5g/year maximum.
3. Adjust the water flow according to the desired DT for the water (Refer to the § **HYDRAULIC PUMPS CURVES**, page XVII).
 - ✓ Check pressure at the inlet and outlet of the plate exchanger
 - ✓ Determine the water flow using a flowmeter or the load loss of the plate exchanger
4. Take a reading of the currents at the compressor, fan and pump terminals.
5. Check there is no dampness during operation: green fluid indicator
6. Take a temperature reading of the cooling and hydraulic circuits after 20 minutes of stabilization, using the controller display.
 - ✓ Check the operating pressures are within normal limits.
 - ✓ Check discharge, suction and liquid temperatures
 - Discharge temperature on the cooling cycle should normally not exceed 115°C.
 - Suction superheat should be 6K \pm 2K.
 - Suction subcooling should be 5K \pm 2K.



Information

It is very important that the unit should operate with a water flow that conforms to the recommendations shown in § **PHYSICAL CHARACTERISTICS - SYSAQUA R32 L - STD version**, page 14. It is dangerous to leave the unit running with a low water flow; this could cause irreparable damage to the components and the plate exchanger. If the unit operates with insufficient flow, its performance will not be optimal.

15.2.4. PUMP MANAGEMENT

In the case of double pump option, both pumps never operate simultaneously: second pump will be started only in case of failure of the first one.

Both pumps are marked with numbers 1 and 2 corresponding to the pump selection switch in the HMI.

The pump change is not automatic. A qualified technician must operate manually. (Refer to the § **PROCEDURE TO SWITCH FROM ONE PUMP TO OTHER**, page 58)

15.2.5. FINAL CHECK

1. All panels and fan guards are in place and secured.
2. Unit clean and free of any installation material.

It is the installer's responsibility to complete the "ON-SITE INFORMATION" form provided in the annex and to hand it to the operator. That document explains what to do in the event of an emergency.

The installer must also provide suitably protected documentation that must remain close to the refrigerating system operating site and be clearly legible.

16. IN CASE OF WARRANTY - MATERIAL RETURN PROCEDURE

Material must not be returned without permission of our After Sales Department.

To return the material, contact your nearest sales office (Refer to the § **Technical support and after sales service**, page 8) and ask for a "return form". The return form shall be sent with the returned material and shall contain all necessary information concerning the problem encountered.

The return of the part is not an order for replacement. Therefore, a purchase order must be entered through your nearest distributor or regional sales office. The order should include part name, part number, model number and serial number of the unit involved.

Following our personal inspection of the returned part, and if it is determined that the failure is due to faulty material or workmanship, and in warranty, credit will be issued on customer's purchase order. All parts shall be returned to our factory, transportation charges prepaid.

17. ORDERING SERVICE AND SPARE PARTS ORDER

The part number, the order confirmation and the unit serial number indicated on the name plate must be provided whenever service works or spare parts are ordered.

For any spare part order, indicate the date of unit installation and date of failure. Use the part number provided by our service spare parts, if it not available, provide full description of the part required.

18. MAINTENANCE

Simple preventive maintenance ensures longevity of your **SYSAQUA R32** :

- Better refrigeration performance
- Reduced power consumption
- Accidental component breakage prevention
- Prevention of heavy, late, and expensive interventions
- Environment protection

Depending on actual operational constraints and regulatory changes, the installer might recommend increased maintenance operations and more frequent inspections.

Prior to carrying out any work on the unit, the following precautions should be adhered to:

1. Make sure that no source of ignition is present in the work area
2. Make sure that the work area is adequately ventilated
3. Make sure that suitable fire extinguishing equipment is available and within reach
4. Make sure that the concentration of R32 in the atmosphere of the work area is continuously controlled in order to be able to warn people of a potentially hazardous situation.
5. Make sure that all electrical power sources are switched off.



Caution

The user is responsible for ensuring that the unit is in perfect working order and that the technical installation and **minimum maintenance** operations have been performed by a qualified technician in accordance with the procedures described in the present manual.

18.1. WEEKLY CHECK

Inspect the entire running installation, while paying particular attention to :

- any damage on the **SYSAQUA R32** housing
- any traces of oil (sign of refrigerating fluid leak)
- any water leak
- the presence of removed protections, doors or lids improperly closed
- the coil's cleanliness.

Check:

- the oil level of the compressors (use sight glass on the oil equalization pipe of compressor tandems)
- the humidity rate of the refrigerating fluid using the fluid indicator
- the operating pressure of the installation
- the water temperature at the plate exchanger inlet and outlet.

When the **SYSAQUA R32** is running, perform a sound check of the compressors, pump and fans. Also check that no vibration can cause breakage or wear by vibrating contact.

It is essential to keep an up to date maintenance booklet to record temperature and pressure readings and all checks and maintenance operations performed on the **SYSAQUA R32**.



Caution

All refrigerating fluid charging, sampling and draining operations must be performed by a skilled technician using equipment adapted to the unit, in agreement with authority regulation in effect on site.

Any inappropriate handling may cause uncontrolled fluid venting into the atmosphere.



Warning

- Isolate unit from power supply before working on unit.



Warning

- Opening the refrigeration circuit then involves vacuum drawing, checking the circuit sealing and recharging refrigerating fluid. For any intervention on the refrigerating fluid circuit, first drain the unit's charge using a refrigerating fluid collection station.

18.2. PERIODIC TABLE OF SERVICE AND MAINTENANCE

TASKS PER COMPONENTS	ACTIONS	1 month	3 months	6 months	12 months	24 months
		Recommended inspection and maintenance interval				
1 - Casing						
1.1	Control possible contaminations, damage and/or corrosion.	Clean and repair if required.			X	
1.2	Check the possible presence of water (condensates, leakages,...).	Clean and look for the cause, then repair.		X		
1.3	Verify thermal insulation aspect	Replace if required.			X	
1.4	Check the state of the anti-vibration pads	Replace if required.			X	
1.5	Check the condition of door gasket.	Replace if required.	At each inspection			
2 - REFRIGERANT CIRCUIT						
2.1	Verify oil compressor level when compressors are off		X			
2.2	Check the lack of gas bubbles in the fluid line		X			
2.3	Check the lack of humidity in the refrigerating fluid		X			
2.4	Check the pipes or capillaries do not rub and vibrate.			X		
2.5	Check the compressors do not emit abnormal noise or vibration.		X			
2.6	Check the backflow temperature.	X				
2.7	Record the operating pressure	Check it is above or below those recorded when the unit was started up.	X			
2.8	Check the compressor fastening screws are tight.			X		
2.9	Check the crankcase heater are powered on during the stop cycle.		X			
2.10	Check the cleanliness of the coil.	Clean if required.	X			
2.11	Test the oil for contamination.	Change the oil if required.			X	
2.12	Check the filter drier clogging.	Replace if required	X			
2.13	Check the operation of the high pressure switch.	Replace if required	X			
2.14	Check the lack of refrigerating fluid leak (visuel + détecteur si nécessaire)	Repair			X	
2.15	Check the cycle reversal valve			X		
2.16	Check the condition of the anti-vibration studs	Replace if required		X		
3 - HYDRAULIC CIRCUIT						
3.1	Check the state of the function, check there is no damage nor corrosion.	Clean and repair.	X			
3.2	Check the condition of the exchanger, in terms of corrosion and functionality.	Clean and repair.		X		
3.3	Check the tightening of the pipe connections and fastening	Readjust and repair if necessary.			X	
3.4	Verify the pressure value of the hydraulic circuit				X	
3.5	Bleed the air.				X	
3.6	Run the isolation valves					
3.7	Check there is no ice set.				X	
3.8	Check the state of the piping thermal insulation.	Repair and replace if required.				
3.9	Check the frost protection devices (glycol-based water, thermostat, ...).	Repair and replace if required. When air temperatures are wintery, and after general stoppage of the installation, the water contained in the plate exchanger may freeze. To prevent such problems, fully drain the unused plate exchanger or protect it by pouring an antifreeze solution into the hydraulic circuit or other devices. ⚠ The manufacturer waives any liability for damage to the plate exchanger caused by water freezing inside the unit.	Whenever there is a risk of freezing			

TASKS PER COMPONENTS		ACTIONS	1	3	6	12	24
			month	months	months	months	months
Recommended inspection and maintenance interval							
3.10	Check filter cleanliness.	Clean	X				
3.11	Check that the hydraulic circuit is filled properly		X				
3.12	Check the condition of the expansion tank (presence of excess corrosion, or gas pressure loss)	Replace if required.	X				
3.13	Check the water pump	If the unit has not been used for a long time, manually rotate the pump shaft and check that it turns freely. For a unit equipped with a double pump, it is recommended to switch from one pump to the other every month or to check that the pump shaft turns freely to prevent the liners sticking.	X				
		Change the pump liner after 15,000 hours running with anti-freeze or 25,000 hours running with water.		X			
3.14	Verify that low water pressure sensor works perfectly		X				
3.15	Record the water temperatures at the plate exchanger inlet and outlet.		X				
4 - ELECTRIC CIRCUIT							
4.1	Check the electrical voltage applied to the unit, which must remain stable within the tolerances specified in the information plates.			X			
4.2	Check that the main supply cable is void of alterations likely to impact the insulation.	Replace if required.		X			
4.3	Check the grounding of the metallic structure	Repair if required.	X				
4.4	Inspect the contacts.	Replace if required.	X				
4.5	Check that all electrical connections of the device are tight	Tighten if required.	X			X	
4.6	Check the thermal protection relays of the motors	Replace if required.	X				
4.7	Check the nominal intensity and condition of the fuses.		X				
4.8	Check the condition of the condensers.		X				
4.9	Clean the compressed air electrical unit to remove any dust or other contaminants building up.			X		X	
4.10	Check the motor windings are insulated.			X			
5 - FAN(S)							
5.1	Check the lack of contamination, corrosion or damage.	Clean if required			X		
5.2	Check proper fastening of the fan.	Tighten if required.			X		
5.3	Check the vanes to guarantee balancing.	Clean if required.				X	
5.4	Check the bearings for noise.	Repair if required.	X				
5.5	Check the condition of the grease and greasers (unless if permanently lubricated).	Re-grease if required (Lithium soap grease DIN 51825-K3N for fans type K, K1, K2).		T>70 °C	X		
5.6	Check the condition of the fan motor.			X			
6 - REGULATION							
6.1	Check the condition of the alarms	Acknowledge them after taking them into consideration	X				
6.2	Check the setting points		X				
6.3	Check the operation of all probes		X				

18.3. MAINTENANCE PROCEDURES

18.3.1. GENERALITIES

This equipment must be submitted for sealing checks **at least once per year, by a professional authorized to perform such an operation**. Refer to national requirements for the frequency of these checks.



Caution

ANY BRAZING OPERATION ON THE COOLING CIRCUIT MUST BE PERFORMED WITH CONSTANT FLOWING NITROGEN.

18.3.2. REFRIGERANT FLUID DRAINING



Caution

Never use the compressor as a vacuum pump to drain the installation.

Before opening the refrigeration circuit, use the SV HP/SV LP service valves to:

1. drain the unit's charge using a recovery unit compatible with flammable refrigerants (non-sparking electrical components) until a residual pressure of 0.3 bar absolute is obtained.
2. purge the circuit with nitrogen
3. expel at a pressure of 30 kPa absolute
4. perform a second nitrogen purge
5. open the circuit.

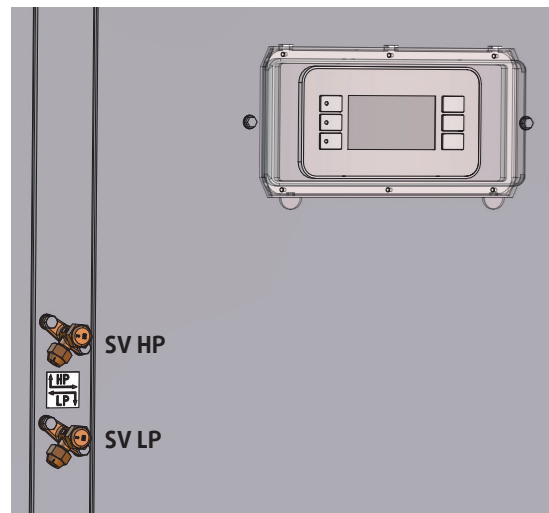

Caution

When opening the refrigeration circuit, be particularly alert to the presence of residual oil in the circuit. That oil may contain dissolved refrigerant and be potentially flammable.

18.3.3. REFRIGERANT FLUID CHARGE

The R32 charging procedure must be carried out by a qualified technician using the SV HP/SV LP service valves.

1. Create a vacuum in the refrigeration circuit to obtain at least 270Pa.
The time it takes to create the vacuum depends on the person performing the task, as well as choosing the right moment to break the vacuum.
2. Fill with R32 up to the amount indicated on the product plate.
3. Close the SV HP and SV LP valves
 - ✓ valve tightening torque: 5N.m
 - ✓ plug tightening torque: 18N.m or 5N.m
4. Perform a leak check of the refrigeration circuit after charging.
The desired result is 5g/year maximum.
5. Check for the absence of humidity: green fluid indicator.
6. Run the unit in refrigerating mode to determine whether the group's charge is correct by checking the sub-refrigeration (Refer to the § **OPERATING CHECK LIST**, page 49).

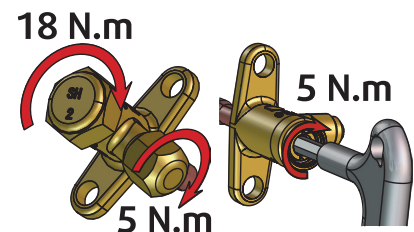

18.3.4. REPAIRS

**Caution**

Only the competent person trained in handling flammable refrigerants (demonstrated by proof of suitable training) is authorized to open or shut off the refrigerant circuit.

Repairs to components containing refrigerant must be undertaken by a competent person in accordance with the following sequence, if appropriate:

1. carry out a risk assessment and gauge the level of risk for the proposed repair.
2. inform the operator of the unit.
3. obtain authorization to proceed with the repair.
4. drain the fluid (Refer to the § **REFRIGERANT FLUID DRAINING**, page 55).
5. disconnect and make safe the components which are to be repaired.
6. clean and purge with nitrogen.
7. carry out the repair.
8. subject the repaired component to testing and verification (test with nitrogen at service pressure, leak testing).

**Caution**

The maximum authorized pressure at the compressor intake (BP) is 17 bar. For all service pressure testing, the pressure should be held at 17 bar, the isolating valve (IV) closed, and finally service pressure attained.

The isolating valve and non-return valve at the compressor exhaust isolate it and protect it as a whole unit.

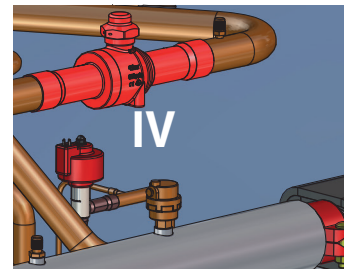
**Caution**

The maximum authorized pressure differential at the expansion valve is 35 bar.

9. open the isolating valve (IV).
10. charge with refrigerant (Refer to the § **REFRIGERANT FLUID CHARGE**, page 55).
11. subject the unit to testing and verification (leak test and operating test).

18.3.5. SPECIFIC COMPONENTS

18.3.5.1. COMPRESSORS

Oil for refrigeration equipment is light and transparent. It maintains its colour for a long operating period.

As a refrigeration system designed and installed properly will run without problem, the compressor oil does not require replacement, even after a long operating period.

Blackened oil has been exposed to impurities in the refrigeration piping system, or excess temperatures on the compressor backflow side, which inevitably degrades oil quality. Blackening oil or degradation of its qualities may also be caused by humidity in the system. Change the oil when its colour changes or when it is degraded.

In this case, before restarting the unit, the refrigeration circuit must be emptied.



Caution

Compressors use polyester oil. During maintenance interventions on the compressor, or if the refrigeration circuit has to be opened in any point, do not forget that this type of oil is highly hygroscopic, and avoid exposing it to the atmosphere during long periods, which would require to change the oil.



Warning

Protect the **SYSAQUA R32** frame so as to get back oil that could flow out accidentally.

18.3.5.2. FILTER DRIER

Refrigeration circuits are fitted with filters drier.

The fluid indicator is used to check the refrigeration flow and humidity rate of the refrigerating fluid. The presence of bubbles indicates that the filter drier is clogged or the charge insufficient.

If you notice that air bubbles are still there even after the filter has been replaced, this means the device has lost part of its cooling product in one or several places, which will need to be detected and repaired.

The glass window contains a colour indicator. Comparing the indicator colour with the scale present on the glass window allows to calculate the humidity rate of the refrigerating fluid. If excessive, change the filter, run the system for one day, then check the humidity rate again.

A humidity rate within the preset limits requires no further intervention. If the humidity rate remains too high, change the filter drier again, start the unit, and run it for another day.

18.3.5.3. AIR COOLED CONDENSER



Caution

Fin edges are sharp and can cause injury hazard. Avoid contact with them.

Condenser coils are composed of copper tubes and aluminium fins. In case of leaks due to damage or shock, the coils must be repaired by one of the authorized Support Centres. To guarantee the best possible operation of the condenser bank, the condenser surface must be maintained as clean as possible, and it must be void of foreign materials (leaves, wires, insects, slag, etc.). A dirty coil will see its absorbed electrical power increase. In addition, condensation pressure could increase and trigger a high pressure alarm.

Clean the air exchanger using a special product for aluminium-copper coils and rinse with water. Do not use hot water nor steam, as these may increase the refrigerating fluid's pressure.



Caution

Avoid damaging the aluminium fins during cleaning. Never use pressurized water without a wide diffuser. Concentrated and/or rotating water jets are strictly forbidden.

18.3.5.4. PLATE HEAT EXCHANGER

Verify the pressure difference between the inlet and the outlet of the heat plate exchanger. If the water pressure and flow rate values do not correspond to the pressure loss curves available in § **HYDRAULIC PUMPS CURVES**, page XVII , the heat plate exchanger may be foul up. To clean it, use a non corrosive solvent to remove calcareous deposits. The equipment used for the external water flow, the quantity of solvent and safety measures applied must be approved by the company supplying the cleaning products, or the one performing these operations.

18.3.5.5. PROCEDURE TO SWITCH FROM ONE PUMP TO OTHER

The procedure to switch from one pump to the other is the following in case of pump 1 failure (for example) :

1. Turn the main power switch of the **SYSAQUA R32** in position OFF
2. Close the upstream and downstream valves of the pump 1 (see photo)
3. Open the upstream and downstream valves of the pump 2
4. Toggle the pump selection in the HMI to pump 2
5. Turn the main power switch of the **SYSAQUA R32** in position ON to restart.

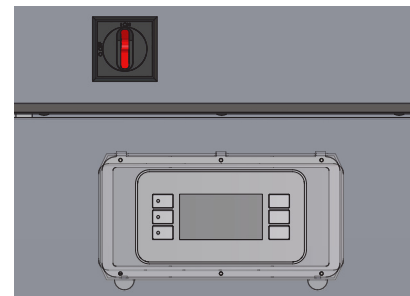
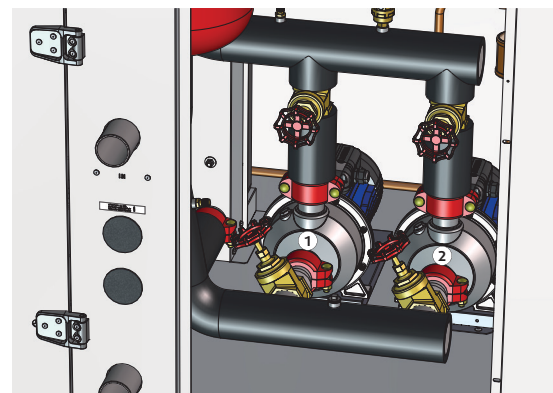
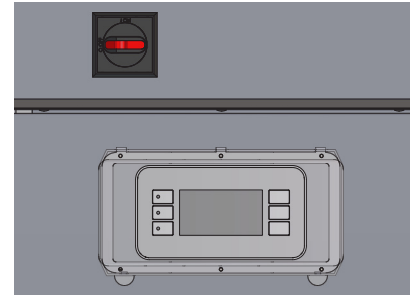

18.3.6. WINTER PROTECTION

In winter, after a general stoppage of the installation or a regulation malfunction, the water contained in the hydraulic circuit may start freezing.

To prevent any problems if the hydraulic circuit is not glycolated, it is recommended to fully drain any circuits not used and to pressurize them with nitrogen or protect them by adding an anti-freeze solution or other measures.

The concentration of anti-freeze solution must be regularly and carefully checked before each winter season.



Caution

The manufacturer waives any liability for damage of a plate exchanger caused by water freezing of water contained inside does not engage the responsibility of the manufacturer with respect to this incident (low winter temperature or water start temperature below 5°C in summer mode).

18.3.7. DISPOSAL

The disposal of refrigerating systems and their component parts must be carried out in accordance with applicable local and national regulations.

Used refrigerant which is not going to be reutilized must be treated as a waste material requiring safe disposal.

The discharge of refrigerants is only permissible when there will be no harm to persons, property or the environment, and provided it is in accordance with legal requirements.

Used oil that cannot be reprocessed must be stored in a suitable separate container and must be treated as a waste material requiring safe disposal.

Other components of the refrigerating system which contain refrigerant and oil must also be disposed of in an appropriate manner.

If necessary, you should seek the advice of a competent person on the disposal of waste refrigerant and oil products.



Information

For additional information on the recovery, reutilization and disposal of refrigerating systems, please see NF EN 378-4, sect. 6.

19. TROUBLE SHOOTING

Problem	Probable cause	Solution
Unit operates continuously but without generating cooling	Insufficient refrigerant fluid charge.	Top up the refrigerant fluid charge.
	Clogged dehumidification filter.	Replace the dehumidification filter.
	Reduced output from one or both circuits	Check the compressor valves and change them if necessary.
Frozen intake line	The overheating setting on the thermostatic pressure relief valve is too low.	Increase the setting.
		Check the refrigerant fluid charge
Excessive noise	Vibrating pipe work	Attach the pipe work correctly.
		Check the pipe work attachments.
	Whistling noise from the thermostatic pressure relief valve	Top up the refrigerant fluid charge.
		Check and replace the dehumidification filter if necessary.
Noisy compressor	Check the condition of the valves.	
	Seized bearings. Replace the compressor	
Low oil level in the compressor	Check the tightness of the compressor attachment nuts.	
	Presence of one or several oil or gas leaks in the circuit	Locate and repair the leaks
	Mechanical compressor damage.	Contact an approved Service Centre.
One or both compressors do not operate.	Sump oil heater resistance fault.	Check the electrical circuit and the condition of the resistance. Replace defective parts if necessary.
	Electrical circuit cut.	Check the electrical circuit and seek out any grounding and/or short-circuits. Check the fuses.
	High pressure pressostat activated.	Reset the pressostat from the control panel and restart the unit. Identify and eliminate the causes of this activation.
	Control circuit fuse blown.	Check the control circuit and seek out any grounding and/or short-circuits. Replace the fuses.
	Connection problem	Check the tightness of all the electrical connection terminals.
	Electrical circuits thermal protection cuts in.	Check the operation of the control and safety devices. Identify and eliminate the cause of the activation.
	Incorrect wiring.	Check the wiring of the control and safety devices.
	Mains voltage too low.	Check the power line. Eliminate any possible problems associated with the system. If the problem is due to the network, inform the Electricity Company.
	Compressor motor short-circuited.	Check the continuity of the motor winding.
Compressor seized	Replace the compressor.	
Circuit stoppage further to the low pressure thermostat being activated.	Presence of a leak.	Identify and repair the leak.
	Insufficient refrigerant fluid charge.	Top up the refrigerant fluid charge.
	Pressostat operating fault.	Replace the pressostat.

Problem	Probable cause	Solution
Circuit stoppage further to the high pressure thermostat being activated.	Incorrect operation of the high pressure pressostat.	Check the operation of the pressostat. Replace it if required.
	Outlet valve partially closed.	Open the valve. Replace it if required.
	Non-condensable particles in the circuit.	Bleed the circuit
	Condenser fan(s) not operating.	Check the wiring and the motors. Repair and replace if required.
Liquid line too hot	Insufficient refrigerant fluid charge.	Locate and eliminate the causes of charge losses and top up the refrigerant fluid charge.
Liquid line frozen	Liquid line valve partially closed.	Checking the opening of all the valves.
	Clogged dehumidification filter.	Replace the filter cartridge.
Fans do not operate.	Electrical circuit problems.	Check the connections.
	Internal circuit thermal cut-out activated.	Contact an approved Service Centre.
Reduced output in both Heating and Cooling mode	Compressor operating fault	Contact an approved Service Centre.
	Dirt in the evaporator water circuit.	Chemical cleaning of the evaporator water circuit.
	Condenser battery blocked.	Clean the condenser battery.
	Insufficient refrigerant fluid charge.	Top up the refrigerant fluid charge.
Evaporator heater is not operating.	No power supply.	Check the main fuse and the auxiliary fuses.
	Heater circuit open	Check the heater and replace if required.
No/ little control over water temperature.	Incorrect thermostat setting.	Check the temperature setting on the control panel.
	Incorrect temperature differential between evaporator inlet and outlet.	Check the water flow and the quantity of liquid in the water circuit.
	Electronic control system malfunction.	Contact an approved Service Centre.
Insufficient water circulation.	Air in the circuit	Bleed the air via the safety valve.
	Deposits or impurities in the evaporator.	Wash out the evaporator by back-flushing.
Unit not operating, no alarm activation	Water circulation fault	Check the pump.
	Flow controller inoperable.	Check the flow controller.
	Differential pressostat inoperable.	Check the differential pressostat.



CAUTION

BEFORE CARRYING OUT ANY OPERATION ON THE EQUIPMENT, CHECK THAT THE ELECTRICAL POWER SUPPLY IS SWITCHED OFF AND THAT IT CANNOT BE SWITCHED ON INADVERTENTLY.

IT IS RECOMMENDED THAT THE DISCONNECT SWITCH BE PADLOCKED

APPENDIX
ANNEXE
ANLAGE
ALLEGATO
ANEXO

APPENDIX / ANNEXE / ANLAGE / ALLEGATO / ANEXO

APPENDIX

DIMENSIONS	III	PRESSURE LOSSES OF THE DESUPERHEATER	XV
SYSAQUA R32 50 - 60 AC FANS.....	IV	HYDRAULIC PUMPS CURVES	XVI
SYSAQUA R32 50 - 60 AC FANS WITH BUFFER TANK.....	V	SYSAQUA R32 50 - 60 - STANDARD PRESSURE PUMP.....	XVI
SYSAQUA R32 50 - 60 EC FANS.....	VI	SYSAQUA R32 50 - 60 - HIGH PRESSURE PUMP.....	XVI
SYSAQUA R32 50 - 60 EC FANS WITH BUFFER TANK.....	VII	WIRING DIAGRAM	XVII
SYSAQUA R32 50 - 60 HPF FANS.....	VIII	LEGEND.....	XVIII
SYSAQUA R32 50 - 60 HPF FANS WITH BUFFER TANK.....	IX	SYSAQUA R32 50 - 60.....	XXI
REFRIGERANT CIRCUIT DIAGRAM	X		
SYSAQUA R32 L.....	XI		
SYSAQUA R32 H.....	XI		
HYDRAULIC CIRCUIT DIAGRAM	XII		
SYSAQUA R32 50-60 WITHOUT PUMP.....	XIII		
SYSAQUA R32 50-60 SINGLE PUMP.....	XIII		
SYSAQUA R32 50-60 DOUBLE PUMP.....	XIII		
SYSAQUA R32 50-60 SINGLE PUMP + TANK.....	XIV		
SYSAQUA R32 50-60 DOUBLE PUMP + TANK.....	XIV		
PRESSURE LOSSES OF THE PLATE HEAT EXCHANGER	XV		

ANNEXE

DIMENSIONS	III	PERTE DE CHARGE DÉSURCHAUFFEUR	XV
SYSAQUA R32 50 - 60 VENTILATEURS AC.....	IV	COURBES DES POMPES HYDRAULIQUES	XVI
SYSAQUA R32 50 - 60 VENTILATEURS AC AVEC BALLON TAMPON V.....	V	SYSAQUA R32 50 - 60 - POMPE PRESSION STANDARD.....	XVI
SYSAQUA R32 50 - 60 VENTILATEURS EC.....	VI	SYSAQUA R32 50 - 60 - POMPE HAUTE PRESSION.....	XVI
SYSAQUA R32 50 - 60 VENTILATEURS EC AVEC BALLON TAMPON VII.....	VII	SCHEMAS ELECTRIQUES	XVII
SYSAQUA R32 50 - 60 VENTILATEURS HPF.....	VIII	LEGENDE.....	XVIII
SYSAQUA R32 50 - 60 VENTILATEURS HPF AVEC BALLON TAMPON.....	IX	SYSAQUA R32 50 - 60.....	XXI
SCHEMA DU CIRCUIT FRIGORIFIQUE	X		
SYSAQUA R32 L.....	XI		
SYSAQUA R32 H.....	XI		
SCHEMA DU CIRCUIT HYDRAULIQUE	XII		
SYSAQUA R32 50-60 SANS POMPE.....	XIII		
SYSAQUA R32 50-60 POMPE SIMPLE.....	XIII		
SYSAQUA R32 50-60 POMPE DOUBLE.....	XIII		
SYSAQUA R32 50-60 POMPE SIMPLE + RÉSERVOIR.....	XIV		
SYSAQUA R32 50-60 POMPE DOUBLE + RÉSERVOIR.....	XIV		
PERTE DE CHARGE DE L'ECHANGEUR A PLAQUES	XV		

ANLAGE

ABMESSUNGEN	III	DRUCKVERLUSTE DES ENTWÄRMETERS	XV
SYSAQUA R32 50 - 60 AC-FANS.....	IV	KURVEN VON HYDRAULIKPUMPEN	XVI
SYSAQUA R32 50 - 60 AC-FANS MIT VORRATSBEHÄLTER.....	V	SYSAQUA R32 50 - 60 - STANDARDDRUCKPUMPE.....	XVI
SYSAQUA R32 50 - 60 EC-FANS.....	VI	SYSAQUA R32 50 - 60 - HOCHDRUCKPUMPE.....	XVI
SYSAQUA R32 50 - 60 EC-FANS MIT VORRATSBEHÄLTER.....	VII	STROMLAUFPLANS	XVII
SYSAQUA R32 50 - 60 HPF-FANS.....	VIII	ERLÄUTERUNG.....	XVIII
SYSAQUA R32 50 - 60 HPF-FANS MIT VORRATSBEHÄLTER.....	IX	SYSAQUA R32 50 - 60.....	XXI
KÄLTEKREISLAUFDIAGRAMM	X		
SYSAQUA R32 L.....	XI		
SYSAQUA R32 H.....	XI		
HYDRAULISCHER SCHALTPLAN	XII		
SYSAQUA R32 50-60 KEINE PUMPE.....	XIII		
SYSAQUA R32 50-60 EINZELPUMPE.....	XIII		
SYSAQUA R32 50-60 DOPPELPUMPE.....	XIII		
SYSAQUA R32 50-60 EINZELPUMPE + TANK.....	XIV		
SYSAQUA R32 50-60 DOPPELPUMPE + TANK.....	XIV		
DRUCKVERLUST PLATTENWÄRMEÜBERTRAGER	XV		

ALLEGATO

DIMENSIONI	III	PERDITA DI CARICO DESURRISCALDATORE	XV
SYSAQUA R32 50 - 60 VENTILATORI AC.....	IV	CURVE DELLE POMPE IDRAULICHE	XVI
SYSAQUA R32 50 - 60 VENTILATORI AC CON SERBATOIO.....	V	SYSAQUA R32 50 - 60 - POMPA PREVALENZA STANDARD.....	XVI
SYSAQUA R32 50 - 60 VENTILATORI EC.....	VI	SYSAQUA R32 50 - 60 - POMPA DI ALTA PREVALENZA.....	XVI
SYSAQUA R32 50 - 60 VENTILATORI EC CON SERBATOIO.....	VII	SCHEMA ELETRICO	XVII
SYSAQUA R32 50 - 60 VENTILATORI HPF.....	VIII	LEGGENDA.....	XVIII
SYSAQUA R32 50 - 60 VENTILATORI HPF CON SERBATOIO.....	IX	SYSAQUA R32 50 - 60.....	XXI
SCHEMA DEL CIRCUITO REFRIGERANTE	X		
SYSAQUA R32 L.....	XI		
SYSAQUA R32 H.....	XI		
SCHEMA CIRCUITALE IDRAULICO	XII		
SYSAQUA R32 50-60 NO POMPA.....	XIII		
SYSAQUA R32 50-60 POMPA SINGOLA.....	XIII		
SYSAQUA R32 50-60 DOPPIA POMPA.....	XIII		
SYSAQUA R32 50-60 POMPA SINGOLA + SERBATOIO.....	XIV		
SYSAQUA R32 50-60 DOPPIA POMPA + SERBATOIO.....	XIV		
PERDITA DI CARICO SCAMBIATORE A PIASTRE	XV		

ANEXO

DIMENSIONES	III	PÉRDIDA DE CARGA DESRECALENTADOR	XV
SYSAQUA R32 50 - 60 VENTILADORES DE CA.....	IV	CURVAS BOMBAS HIDRÁULICAS	XVI
SYSAQUA R32 50 - 60 VENTILADORES DE CA CON BALÓN INTERMEDIO.....	V	SYSAQUA R32 50 - 60 - BOMBA DE PRESIÓN ESTÁNDAR.....	XVI
SYSAQUA R32 50 - 60 VENTILADORES CE.....	VI	SYSAQUA R32 50 - 60 - BOMBA DE ALTA PRESIÓN.....	XVI
SYSAQUA R32 50 - 60 VENTILADORES CE CON BALÓN INTERMEDIO.....	VII	ESQUEMA ELECTRICO	XVII
SYSAQUA R32 50 - 60 VENTILADORES HPF.....	VIII	LEYENDA.....	XVIII
SYSAQUA R32 50 - 60 VENTILADORES HPF CON BALÓN INTERMEDIO.....	IX	SYSAQUA R32 50 - 60.....	XXI
ESQUEMA DEL CIRCUITO FRIGORIFÍCO	X		
SYSAQUA R32 L.....	XI		
SYSAQUA R32 H.....	XI		
ESQUEMA CIRCULAR HIDRÁULICO	XII		
SYSAQUA R32 50-60 SIN BOMBA.....	XIII		
SYSAQUA R32 50-60 BOMBA SIMPLE.....	XIII		
SYSAQUA R32 50-60 BOMBA DOBLE.....	XIII		
SYSAQUA R32 50-60 BOMBA SIMPLE + TANQUE.....	XIV		
SYSAQUA R32 50-60 BOMBA DOBLE + TANQUE.....	XIV		
PÉRDIDA DE CARGA INTERCAMBIADOR DE PLACAS	XV		

**DIMENSIONS
DIMENSIONS
ABMESSUNGEN
DIMENSIONI
DIMENSIONES**

	English		Français		Deutsch
F	Electrical power supply	F	Alimentation électrique	F	Stromversorgung
I	Gauge kit (optional)	I	Kit de jauge (en option)	I	Messgerätesatz (optional)
L	Main switch	L	Sectionneur général	L	Hauptschalter
M	Control keypad / display	M	Afficheur/clavier régulateur	M	Bedientastatur / Display
D	Desuperheater (optional)	D	Récupération de chaleur partielle	D	Enthitzer
S	Safety valve discharge	S	Échappement soupape de sécurité	S	Auslass Sicherheitsventil
P1/P2/P3/P4	AVM position (optional)	P1/P2/P3/P4	AVM emplacement (optionnel)	P1/P2/P3/P4	AVM-Position (optional)

	Italiano		Español
F	Alimentazione elettrica	F	Alimentación
I	Kit manometro (opzionale)	I	Kit medidor (opcional)
L	Interruttore principale	L	Interruptor general
M	Tastiera/display di controllo	M	Teclado / pantalla de control
D	Desurriscaldatore (opzionale)	D	Desobrecalentador
S	Scarico valvola di sicurezza	S	Válvula de descarga de seguridad
P1/P2/P3/P4	Posizione AVM (opzionale)	P1/P2/P3/P4	Posición AVM (opcional)

APPENDIX / ANNEXE / ANLAGE / ALLEGATO / ANEXO

SYSAQUA R32 50 - 60 AC FANS

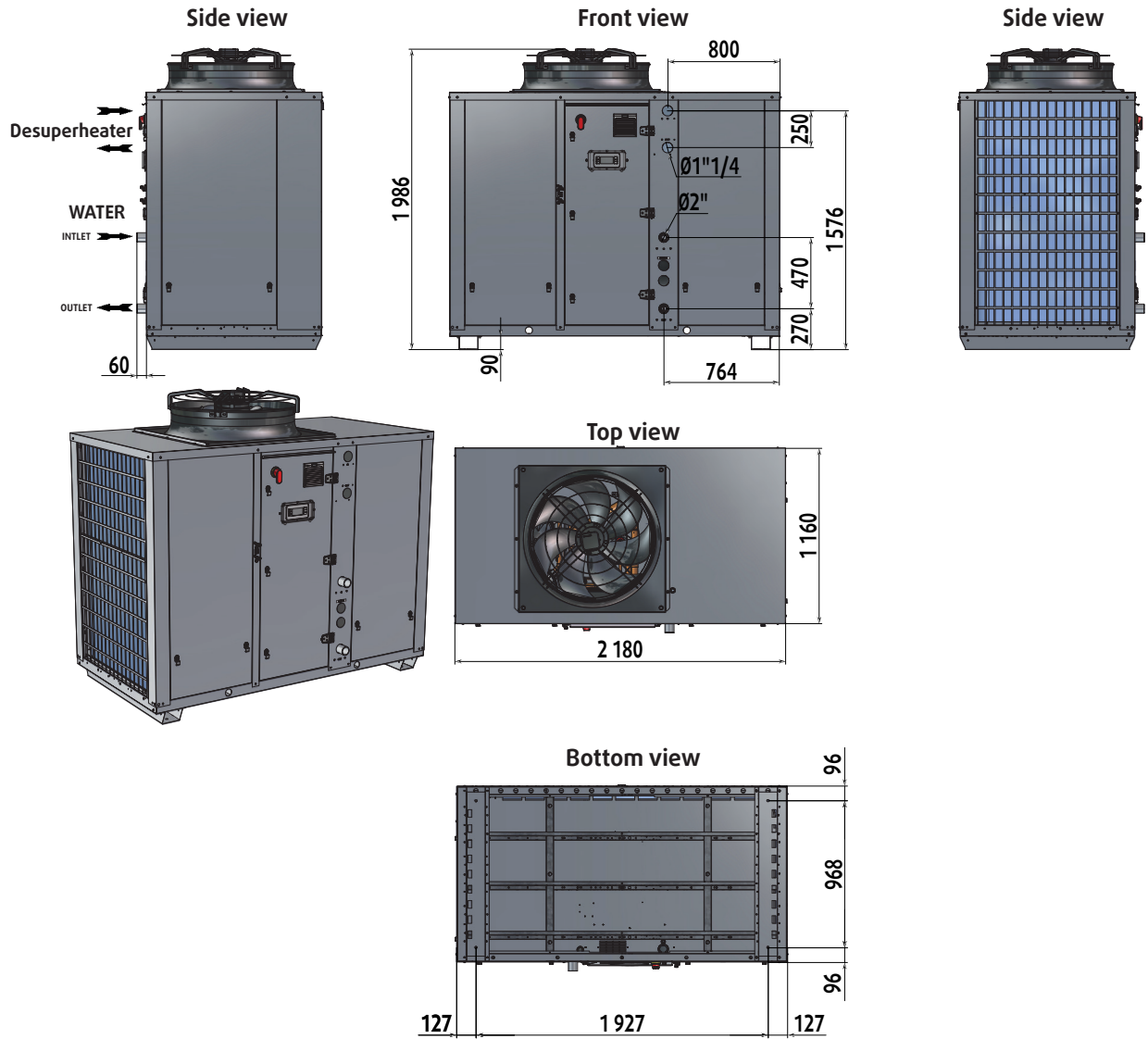

APPENDIX / ANNEXE / ANLAGE / ALLEGATO / ANEXO

SYSAQUA R32 50 - 60 AC FANS WITH BUFFER TANK

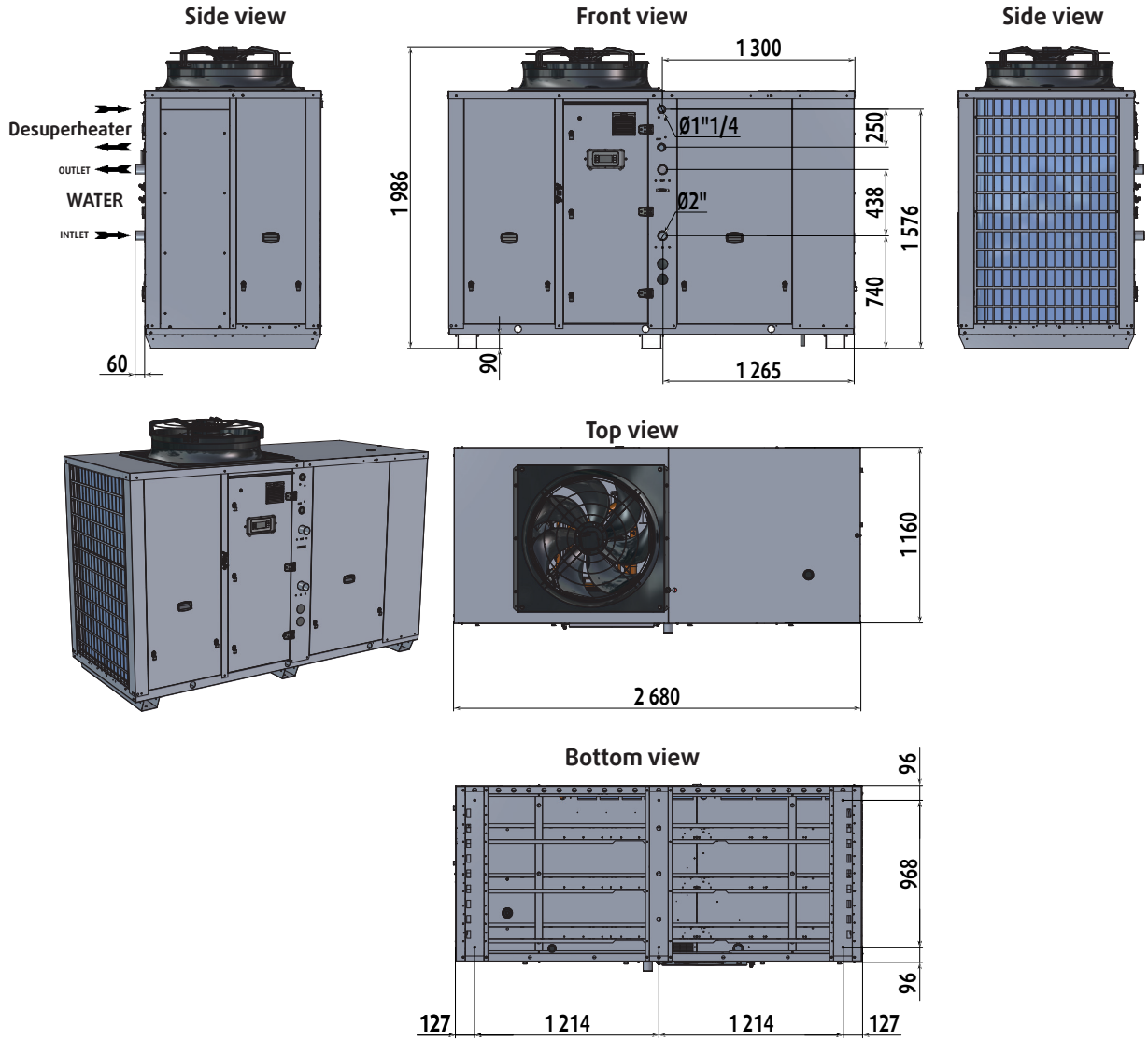

APPENDIX / ANNEXE / ANLAGE / ALLEGATO / ANEXO

SYSAQUA R32 50 - 60 EC FANS

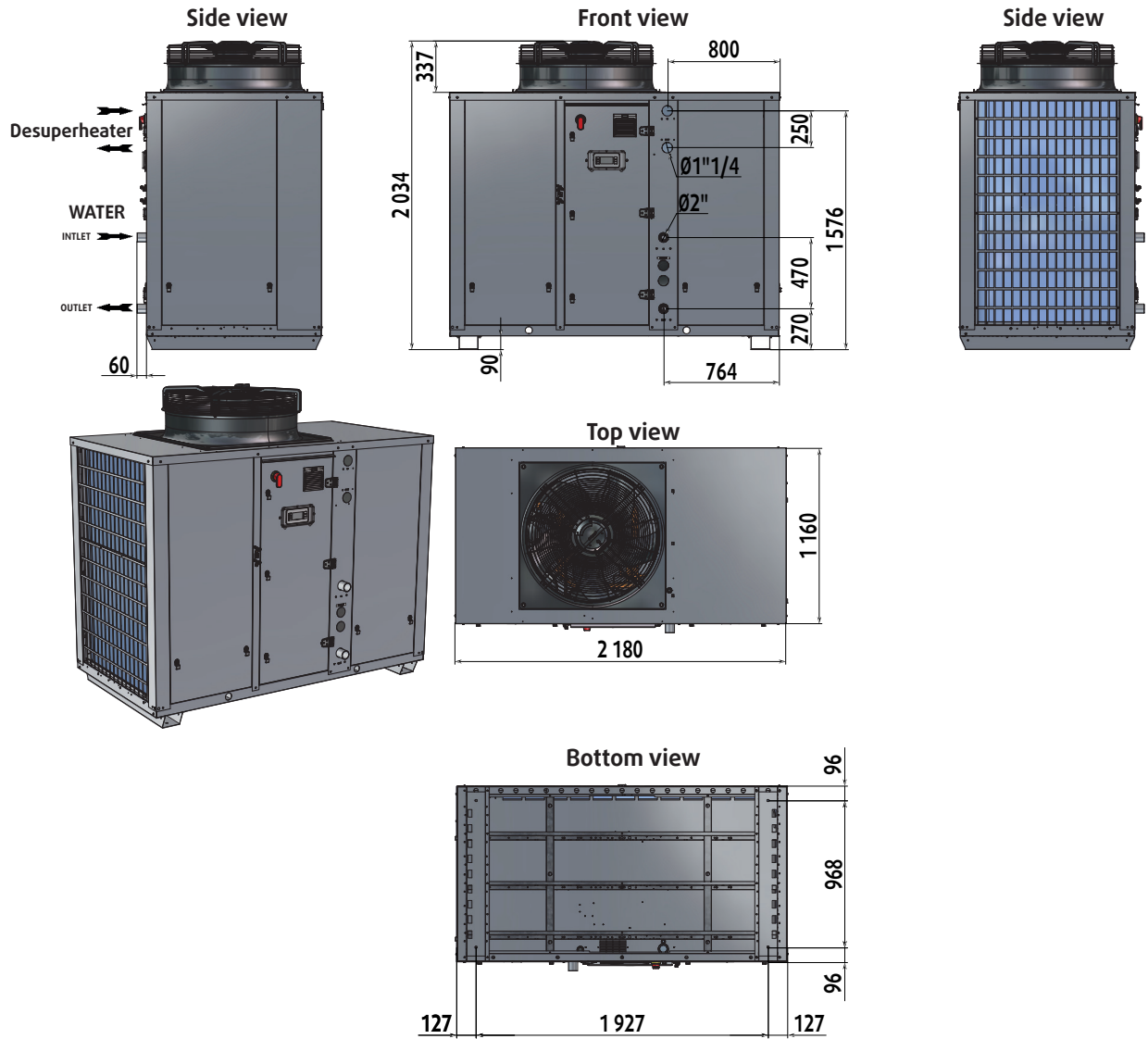

SYSAQUA R32 50 - 60 EC FANS WITH BUFFER TANK

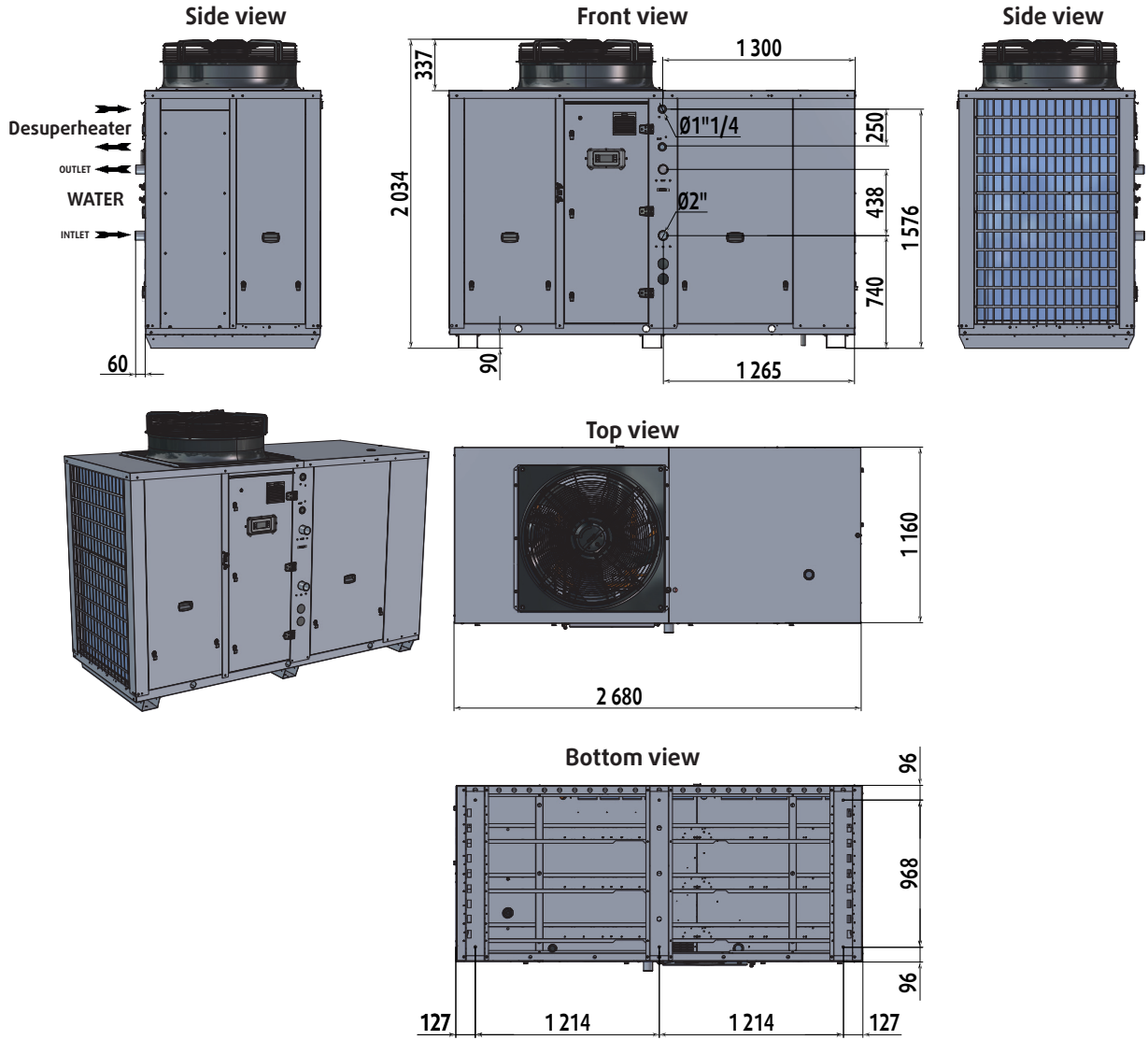

APPENDIX / ANNEXE / ANLAGE / ALLEGATO / ANEXO

SYSAQUA R32 50 - 60 HPF FANS

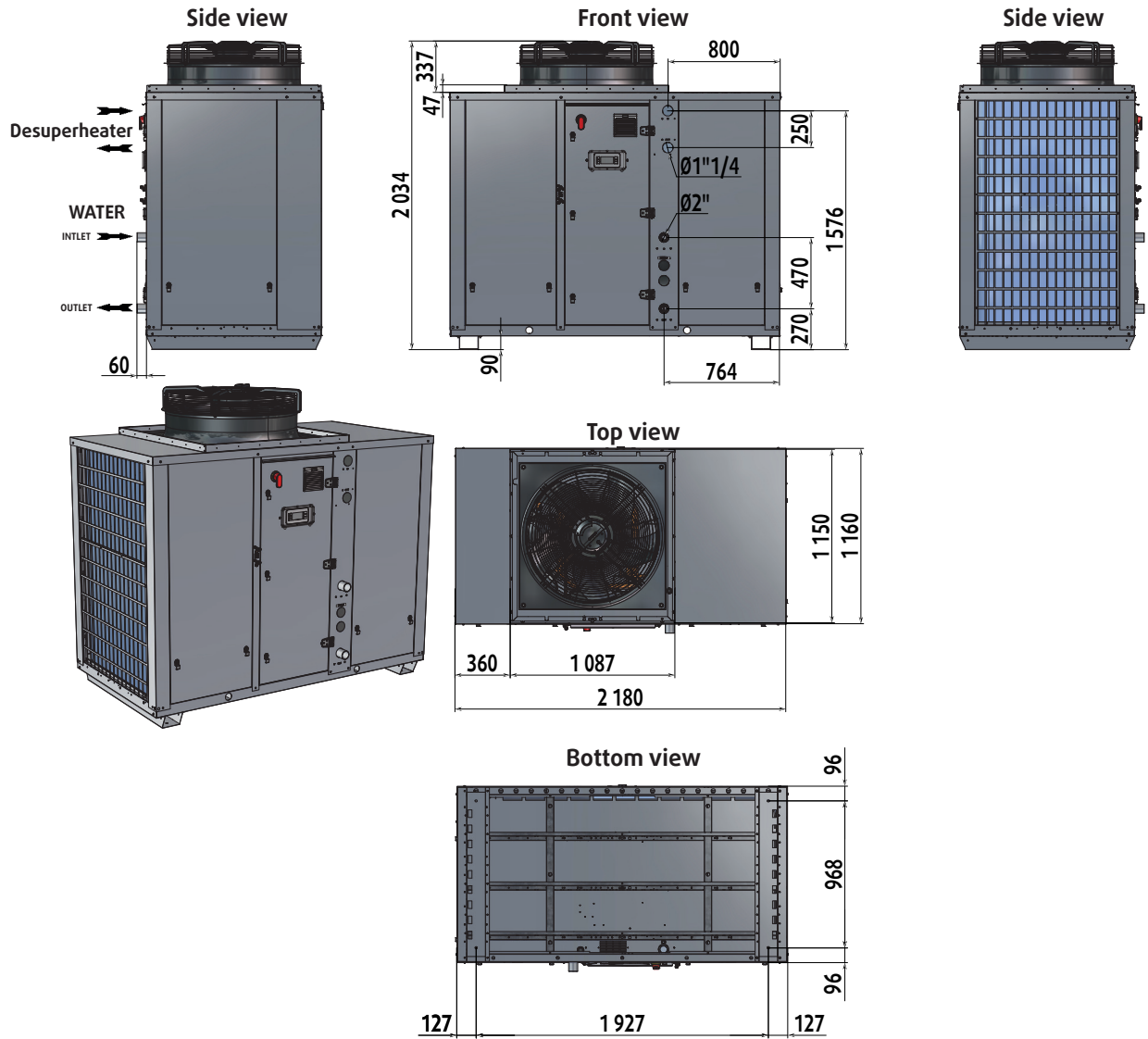

APPENDIX / ANNEXE / ANLAGE / ALLEGATO / ANEXO

SYSAQUA R32 50 - 60 HPF FANS WITH BUFFER TANK

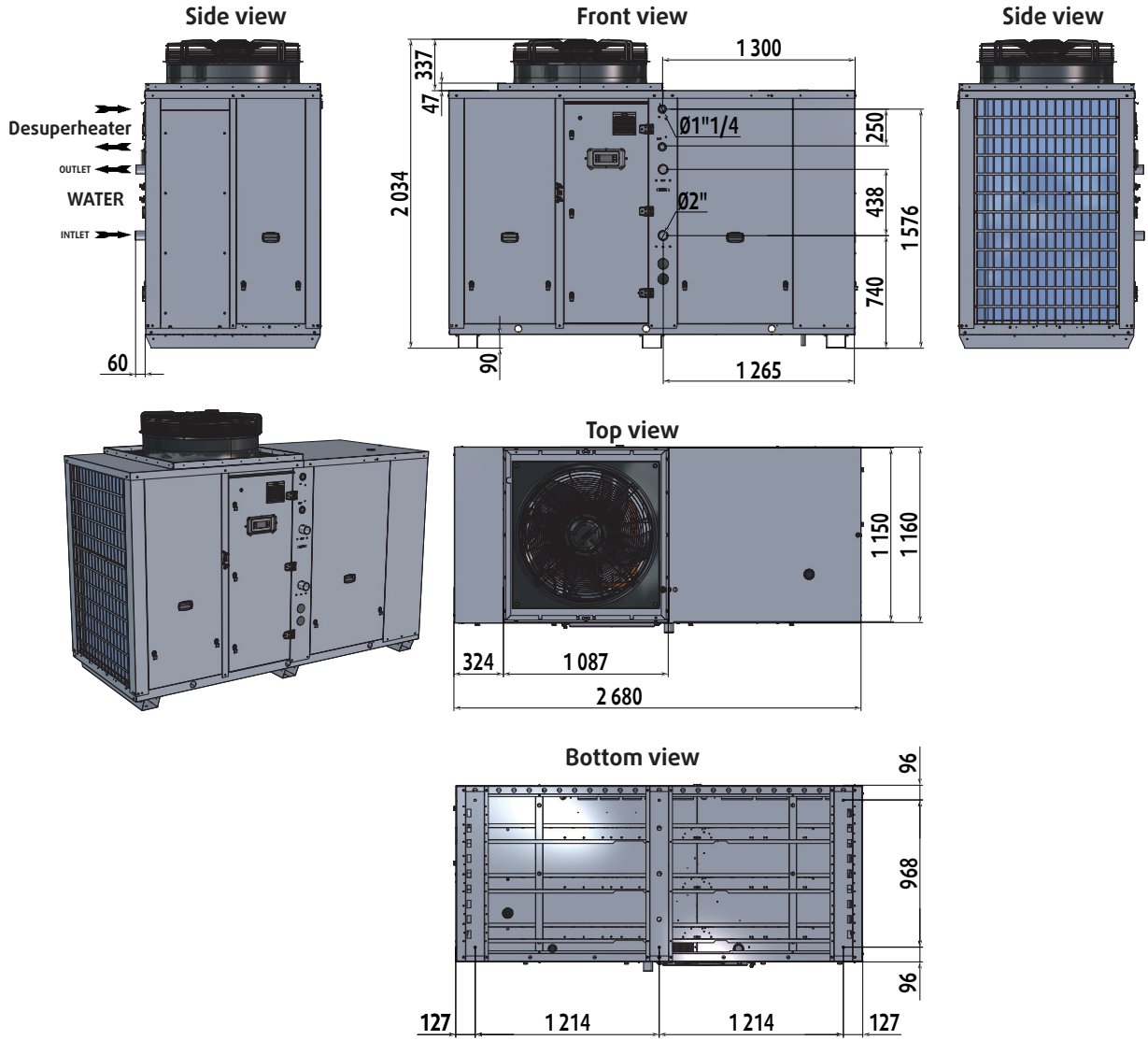

APPENDIX / ANNEXE / ANLAGE / ALLEGATO / ANEXO

REFRIGERANT CIRCUIT DIAGRAM SCHEMA DU CIRCUIT FRIGORIFIQUE KÄLTEKREISLAUFDIAGRAMM SCHEMA DEL CIRCUITO REFRIGERANTE ESQUEMA DEL CIRCUITO FRIGORIFÍCO

English		Français		Deutsch	
1	Tandem scroll compressors	1	Compresseurs scroll en tandem	1	Tandem-Scrollkompressoren
2	Air cooled condenser	2	Condenseur à air	2	Verflüssigerbündel
3	Filter drier	3	Filtre déshydrateur	3	Filtertrockner
4	Electronic expansion valve	4	Détendeur électronique	4	Elektronisches Expansionsventil
5	Globe valve	5	Robinet de sectionnement à bille	5	Absperrkugelhahn
9	Sight glass	9	Voyant liquide	9	Schauglas
10	Heat exchanger	10	Échangeur de chaleur	10	Wärmetauscher
11	Desuperheater (option)	11	Désurchauffeur (option)	11	Enthitzer (Option)
12	LP/HP Service valve	12	Vanne de service basse/haute pression (LP/HP)	12	Betriebsventil Nieder-/Hochdruck (LP/HP)
A	High pressure switch	A	Pressostat haute pression	A	Überdruckschalter
AT	High pressure transducer	AT	Transducteur haute pression	AT	Hochdruckgeber
BT	Low pressure transducer	BT	Transducteur basse pression	BT	Niederdruckgeber
D	Air temperature sensor	D	Sonde température air	D	Außenlufttemperaturfühler
E	Outlet water temperature sensor	E	Capteur de température sortie d'eau	E	Temperatursensor Wasserauslauf
F	Inlet water temperature sensor	F	Capteur de température entrée d'eau	F	Temperatursensor Wassereinlauf
FS	Water flow switch	FS	Fluxostat eau	FS	Strömungswächter Wasser
G	PED Pressure relief valve	G	Soupape PED haute pression	G	PED Hochdruckventil
H	Defrost temperature sensor	H	Capteur de température dégivrage	H	Temperatursensor Entfrostdung
M	Discharge temperature	M	Sonde température de sortie	M	Temperatursensor Vorlauf
N	Suction temperature sensor	N	Sonde température d'aspiration	N	Temperatursensor Saugen
S	1/4" Schrader connection	S	Raccord Schrader de 1/4"	S	1/4" Schrader-Anschluss

Italiano		Español	
1	Compressori scroll in tandem	1	Compresores scroll en paralelo
2	Condensatore ad aria	2	Condensador de aire
3	Filtro disidratatore	3	Filtro deshidratador
4	Valvola espansione elettronica	4	Reductor electrónico
5	Rubinetto a sfera	5	Vaso de expansión
9	Spia del liquido	9	Indicador luminoso de líquido
10	Scambiatore di calore	10	Intercambiador de calor
11	Desurriscaldatore (opzione)	11	Desrecaentador (opcional)
12	Valvola di servizio bassa/alta pressione (LP/HP)	12	Válvula de servicio LP / HP
A	Pressostato di alta pressione	A	Presóstato de alta presión
AT	Trasduttore di alta pressione	AT	Transductor de alta presión
BT	Trasduttore di bassa pressione	BT	Transductor de baja presión
D	Sonda temperatura aria	D	Sonda de temperatura de aire
E	Sensore temperatura uscita acqua	E	Detector de temperatura del agua de salida
F	Sensore temperatura ingresso acqua	F	Detector de temperatura del agua de entrada
FS	Flussostato acqua	FS	Flujóstato de agua
G	Valvola PED di alta pressione	G	Válvula de alivio de presión PED
H	Sensore temperatura sbrinamento	H	Detector de temperatura de desescarche
M	Sonda temperatura di mandata	M	Sonda de temperatura descarga
N	Sensore temperatura di aspirazione	N	Detector de temperatura de aspiración
S	Attacco Schrader da 1/4"	S	Conexión Schrader de 1/4 "

SYSAQUA R32 L

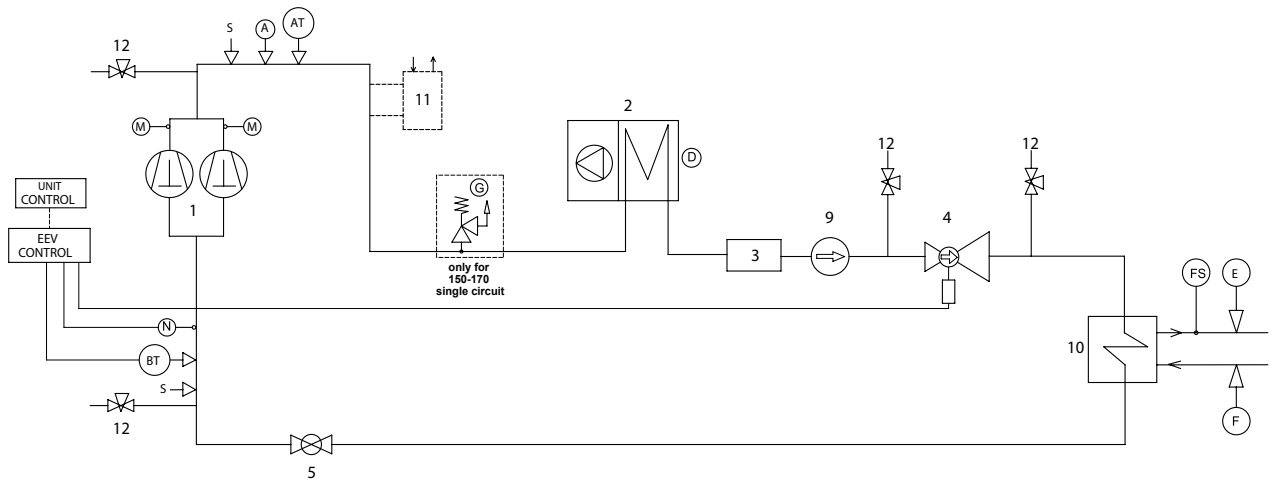

SYSAQUA R32 H

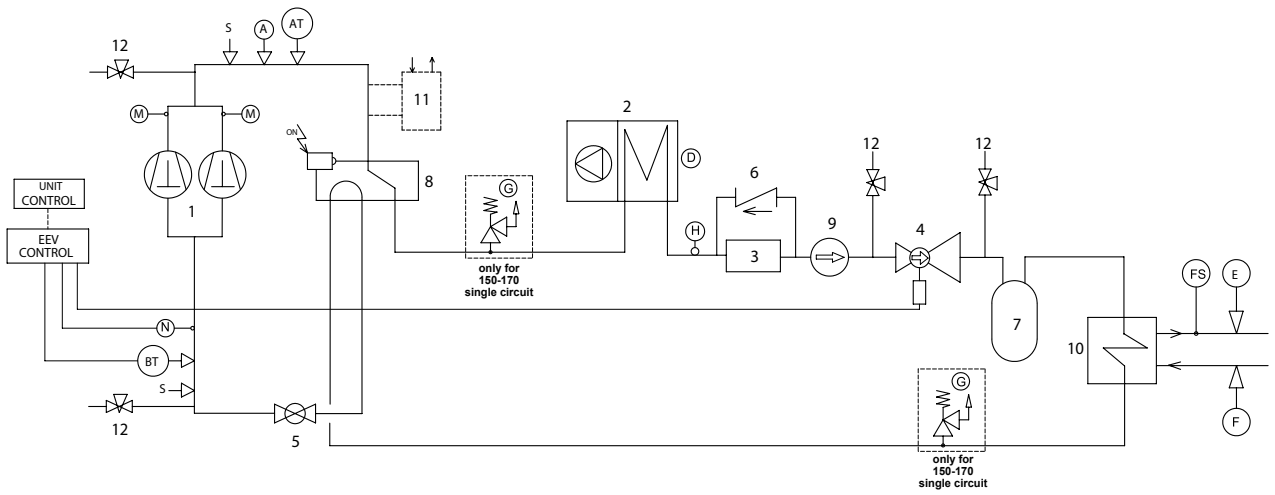

HYDRAULIC CIRCUIT DIAGRAM SCHEMA DU CIRCUIT HYDRAULIQUE HYDRAULISCHER SCHALTPLAN SCHEMA CIRCUITALE IDRAULICO ESQUEMA CIRCULAR HIDRÁULICO

English

COMPONENTS

1	Plate heat exchanger
2	Pump
3	Draining valve
4	Water buffer tank
5	Water Filter
6A	Gate valve
6B	Check valve
7	Pressure expansion tank
8	Pression point/drainage
9	Water outlet
10	Water inlet
11	Globe valve
12	Flexible pipes
13	By pass valve

SAFETY/CONTROL DEVICES

A	Inlet water temperature sensor
B	Outlet water temperature sensor
C	Water differential pressure switch
D	Vent valve
E	Water safety valve (3 bar)
FS	Flow switch
G	Thermometer
H	Variable frequency drive
-----	Unit side
O	Probes

Français

COMPOSANTS

1	Echangeur à plaques
2	Pompe
3	Vanne de vidange
4	Réservoir de stockage eau
5	Filtre à eau
6A	Vanne à guillotine
6B	Soupape de retenue
7	Vase d'expansion
8	Point de pression/évacuation
9	Sortie de l'eau
10	Entrée de l'eau
11	Vanne d'arrêt
12	Tuyaux flexibles
13	Vanne de by-pass

DISPOSITIFS DE SÉCURITÉ / CONTRÔLE

A	Sonde température d'entrée d'eau
B	Sonde température sortie d'eau
C	Pressostat différentiel d'eau
D	Vanne de purge
E	Vanne de sécurité d'eau (3 bars)
FS	Détecteur de débit
G	Thermomètre
H	Variateur de fréquence
-----	Côté unité
O	Sondes

Deutsch

KOMPONENTEN

1	Plattenwärmeübertrager
2	Pumpe
3	Ablassventil
4	Wasserspeicherbehälter
5	Wasserfilter
6A	Absperrschieber
6B	Rückschlagventil
7	Expansionsgefäß
8	Druckabgreifpunkt/Auslass
9	Wasserauslauf
10	Wassereinlauf
11	Absperrhahn
12	Schläuche
13	Umgehungsventil

SICHERHEITS-/KONTROLLVORRICHTUNGEN

A	Temperatursensor Wassereinlauf
B	Temperatursensor Wasserauslauf
C	Wasserdifferential-Druckwächter
D	Entlüftungsventil
E	Wasser-Sicherheitsventil (3 bar)
FS	Strömungswächter
G	Thermometer
H	Frequenzwandler
-----	Seite Einheit
O	Fühler

Italiano

COMPONENTI

1	Scambiatore a piastre
2	Pompa
3	Valvola di scarico
4	Serbatoio di accumulo acqua
5	Filtro acqua
6A	Valvola d'intercettazione
6B	Valvola di non-ritorno
7	Vaso di espansione
8	Punto di pressione/scarico
9	Uscita dell'acqua
10	Ingresso dell'acqua
11	Rubinetto a sfera
12	Tubi flessibili
13	Valvola di by-pass

DISPOSITIVI DI SICUREZZA / CONTROLLO

A	Sonda temperatura ingresso acqua
B	Sonda temperatura uscita acqua
C	Pressostato differenziale acqua
D	Valvola di sfianto
E	Valvola di sicurezza dell'acqua (3 bar)
FS	Flussostato
G	Termometro
H	Variatore di frequenza
-----	Lato unità
O	Sonde

Español

COMPONENTES

1	Intercambiador de placas
2	Bomba
3	Válvula de vaciado
4	Depósito de reserva de agua
5	Filtro de agua
6A	Válvula de compuerta
6B	Válvula de retención
7	Vaso de expansión
8	Punto de presión/drenaje
9	Entrada de agua
10	Salida de agua
11	Válvula de parada
12	Tuberías flexibles
13	Válvula de derivación

DISPOSITIVOS DE SEGURIDAD / CONTROL

A	Sonda de temperatura de entrada de agua
B	Sonda de temperatura de salida de agua
C	Presostato diferencial de agua
D	Válvula de purga
E	Válvula de seguridad de agua (3 bar)
FS	Detector de caudal
G	Termómetro
H	Accionamiento de frecuencia variable
-----	Lado equipo
O	Sondas

SYSAQUA R32 50-60 WITHOUT PUMP

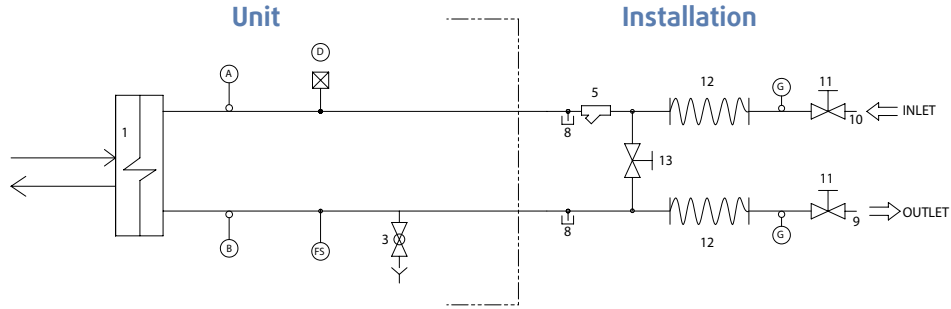

SYSAQUA R32 50-60 SINGLE PUMP

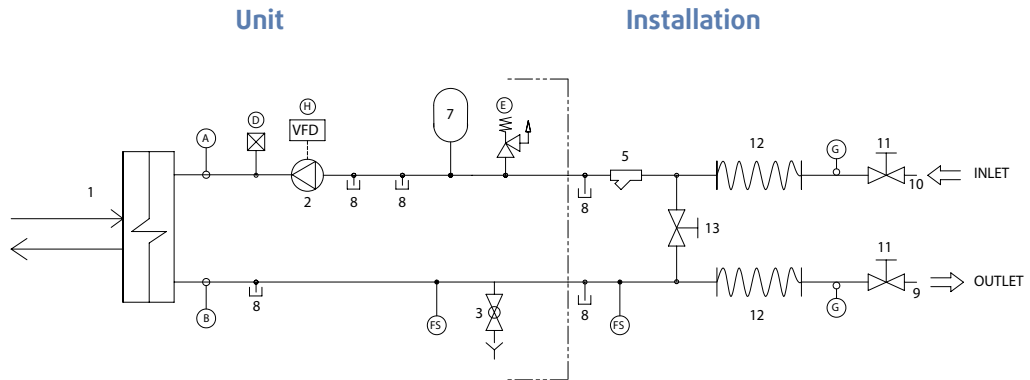

SYSAQUA R32 50-60 DOUBLE PUMP

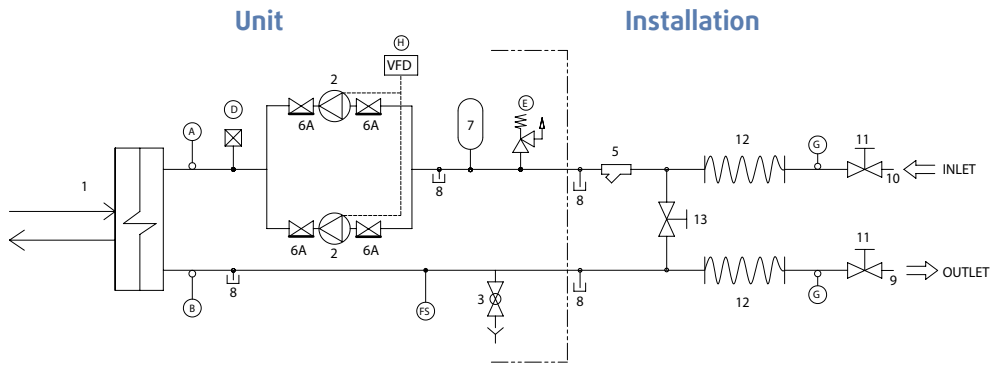

APPENDIX / ANNEXE / ANLAGE / ALLEGATO / ANEXO

SYSAQUA R32 50-60 SINGLE PUMP + TANK

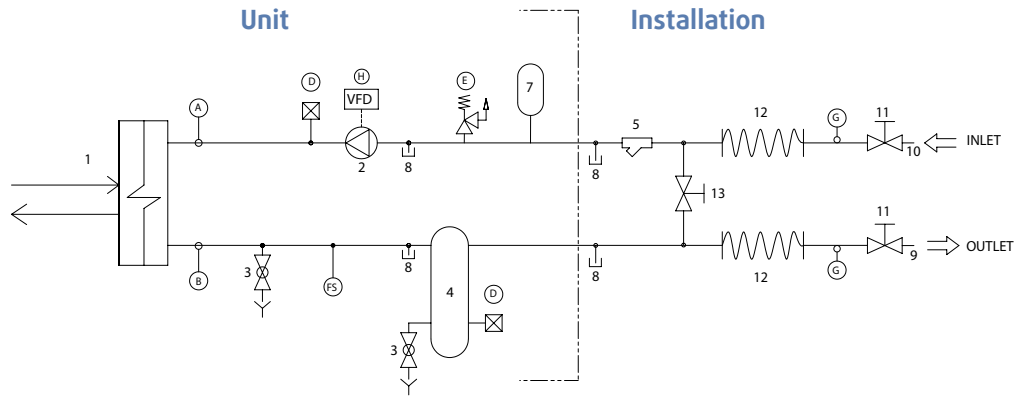

SYSAQUA R32 50-60 DOUBLE PUMP + TANK

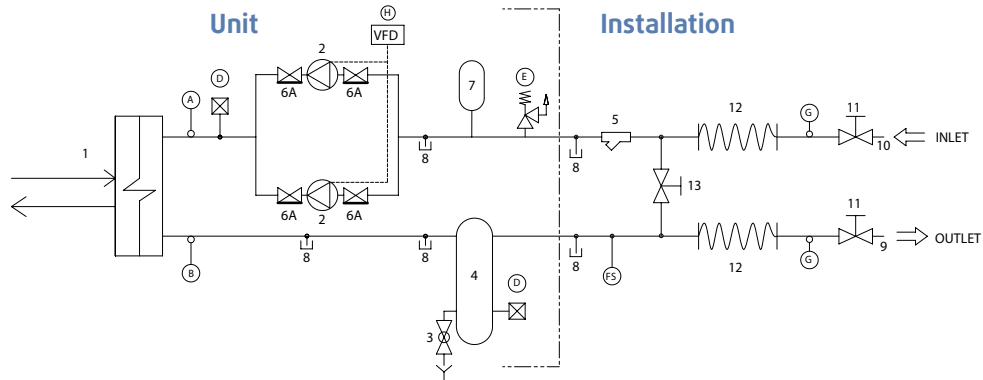

**PRESSURE LOSSES OF THE PLATE HEAT EXCHANGER
 PERTE DE CHARGE DE L'ECHANGEUR A PLAQUES
 DRUCKVERLUST PLATTENWÄRMEÜBERTRAGER
 PERDITA DI CARICO SCAMBIATORE A PIASTRE
 PÉRDIDA DE CARGA INTERCAMBIADOR DE PLACAS**

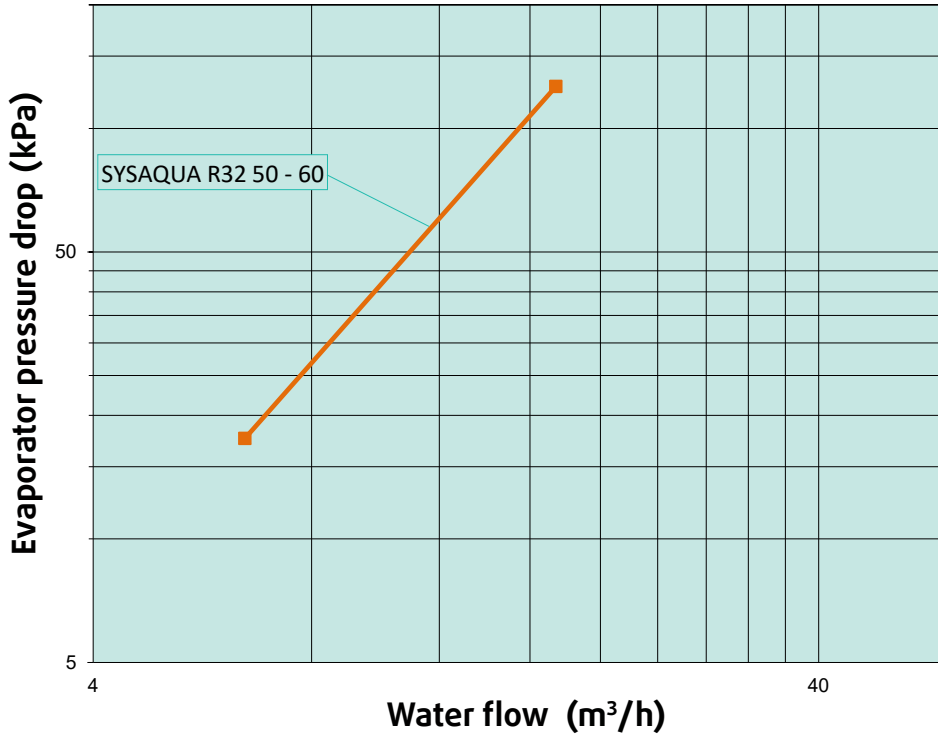

**PRESSURE LOSSES OF THE DESUPERHEATER
 PERTE DE CHARGE DÉSURCHAUFFEUR
 DRUCKVERLUSTE DES ENTWÄRMETERS
 PERDITA DI CARICO DESURRISCALDATORE
 PÉRDIDA DE CARGA DESRECALENTADOR**

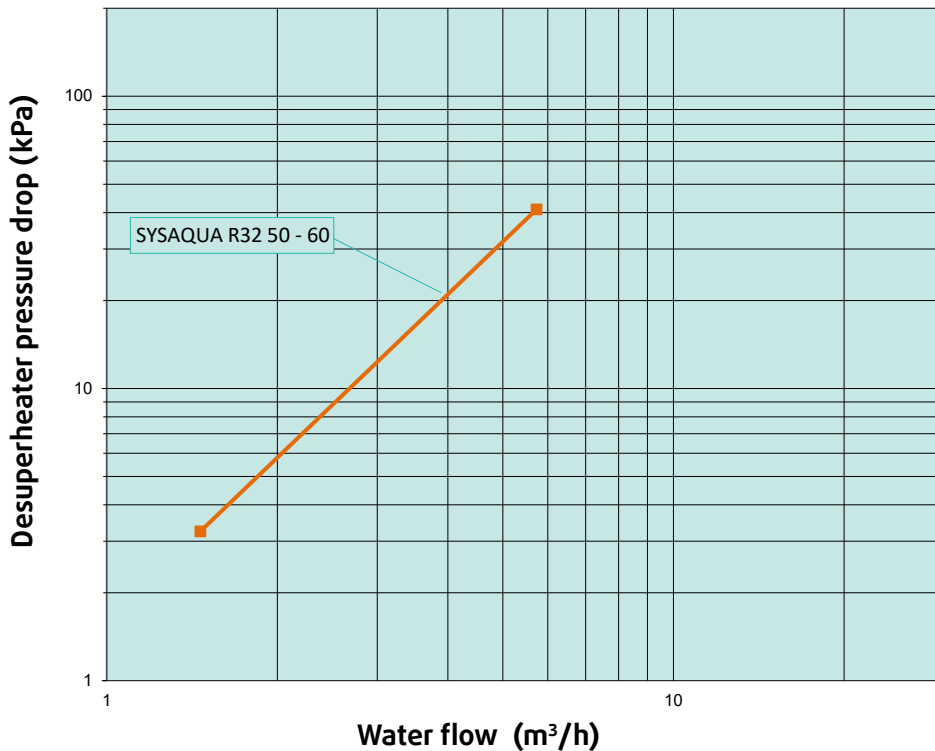

HYDRAULIC PUMPS CURVES
 COURBES DES POMPES HYDRAULIQUES
 KURVEN VON HYDRAULIKPUMPEN
 CURVE DELLE POMPE IDRAULICHE
 CURVAS BOMBAS HIDRÁULICAS

SYSAQUA R32 50 - 60 - STANDARD PRESSURE PUMP

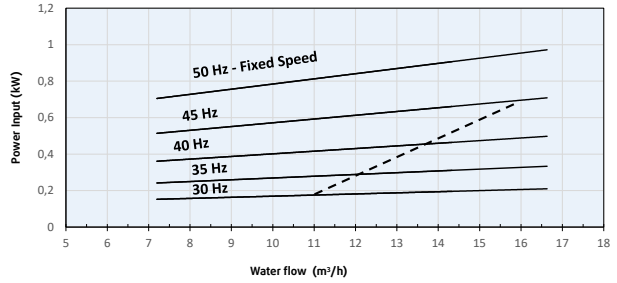
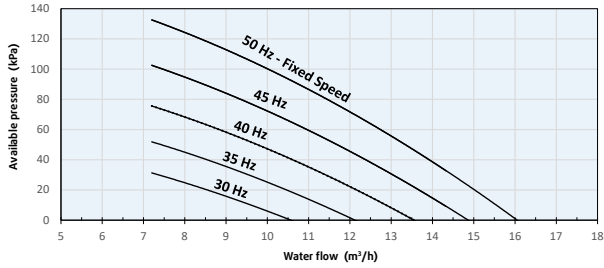

SYSAQUA R32 50 - 60 - HIGH PRESSURE PUMP

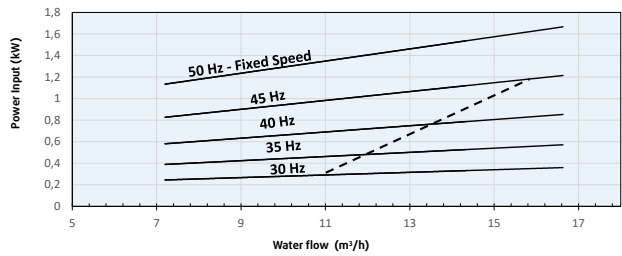
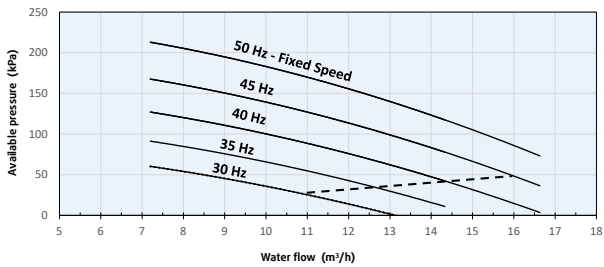

WIRING DIAGRAM SCHEMAS ELECTRIQUES STROMLAUFPLANS SCHEMA ELETRICO ESQUEMA ELECTRICO

TAKE CARE!

These wiring diagrams are correct at the time of publication. Manufacturing changes can lead to modifications. Always refer to the diagram supplied with the product.

ATTENTION

Ces schémas sont corrects au moment de la publication. Les variantes en fabrication peuvent entraîner des modifications. Reportez-vous toujours au schéma livré avec le produit.

ACHTUNG!

Diese Stromlaufplans sind zum Zeitpunkt der Veröffentlichung gültig. In Herstellung befindliche Varianten können Änderungen mit sich bringen. In jedem Fall den mit dem Produkt gelieferten Stromlaufplan hinzuziehen.

ATTENZIONE !

Questi schemi sono corretti al momento della pubblicazione. Le varianti apportate nel corso della fabbricazione possono comportare modifiche. Far sempre riferimento allo schema fornito con il prodotto.

ATENCIÓN !

Esto esquemas son correctos en el momento de la publicación. Pero las variantes en la fabricación pueden ser motivo de modificaciones. Remítase siempre al esquema entregado con el producto.



POWER SUPPLY MUST BE SWITCHED OFF BEFORE STARTING TO WORK IN THE ELECTRIC CONTROL BOXES!

MISE HORS TENSION OBLIGATOIRE AVANT TOUTE INTERVENTION DANS LES BOITIERS ELECTRIQUES.

VOR JEDEM EINGRIFF AN DEN ANSCHLUßKÄSTEN UNBEDINGT DAS GERÄT ABSCHALTEN!

PRIMA DI OGNI INTERVENTO SULLE CASSETTE ELETTICHE ESCLUDERE TASSATIVAMENTE L'ALIMENTAZIONE !

PUESTA FUERA DE TNSIÓN OBLIGATORIA ANTES DE CUALQUIER INTERVENCIÓN EN LAS CAJAS ELÉCTRICAS!

APPENDIX / ANNEXE / ANLAGE / ALLEGATO / ANEXO

LEGEND

	English	Français	Deutsch	Italiano	Español
	CONTROL AND REGULATION	SCHEMAS DE COMMANDE	STEUERPLÄNE	SCHEMI DI COMANDO	ESQUEMAS DE COMANDO
	DESCRIPTION	DESIGNATION	BEZEICHNUNG	DENOMINAZIONE	DESIGNACIÓN
AFEH-0.1	Antifreeze electric heater	Résistances anti-gel	Frostschutz-Widerstand	Resistenza antigelo	Resistencia anticongelación
AFEH-0.2					
C-1.1	Compressors	Compresseurs	Verdichter	Compressori	Compresores
C-1.2					
CDI-1.1	Discharge temperature probe	Sondes de température de refroidement	Auslass-Temperaturfühler	Sonda di temperatura di mandata	Sonda de temperatura de descarga
CDT-1.2					
CH-1.1	Compressors crankcase heater	Résistances de carter des compresseurs	Ölsumpfheizungen der Verdichter	Resistenze del carter dei compressori	Resistencias de cárter de los compresores
CH-1.2					
CST-1.1	Suction temperature sensor	Sonde de température d'aspiration	Saug-Temperaturfühler	Sonda di temperatura di aspirazione	Sonda de temperatura de succión
EEV-1.1	Electronic expansion valve	Détendeur électronique	Elektronisches Expansionsventil	Valvola di espansione elettronica	Válvula de expansión electrónica
EH-0.1	Heating resistors	Résistances chauffantes	Heizwiderstände	Resistenze di riscaldamento	Resistencias de calefacción
EWT-0.1	Inlet water temperature probe	Sonde de température d'entrée d'eau	Wassereintritt-Temperaturfühler	Sonda di temperatura di ingresso dell'acqua	Sonda de temperatura de entrada de agua
FA-0.1	Automatic reset heating safety thermostat (option)	Thermostat de sécurité chauffage à réarmement automatique (option)	Sicherheitsthermostat Heizung mit automatischer Wiedereinschaltvorrichtung (Option)	Termostato di sicurezza riscaldamento a ripristino automatico (optional)	Termostato de seguridad de calefacción con restablecimiento automático (opcional)
FF-0.1	Fuse terminal + fuse 2,5A	Borne fusible + fusible 2,5A	Sicherungsklemme + Sicherung 2,5A	Portafusibile + fusibile 2,5A	Terminal de fusible + fusible 2,5A
FOF-1.1	Outdoor fans motors internal protection	Sécurité interne des moteurs des ventilations extérieures	Eingebauter Wärmeschutzschalter des Motors der externen Lüftung	Sicurezza interna del motore della ventilazione esterna	Seguridad interna del motor de la ventilación exterior
FOF-1.2					
FPC-0.1	Three-phase network control relay (phase sequence and cut-out)	Module de contrôle d'ordre et de coupure de phases	Phasenabschaltungs- und reihenfolge Kontrollmodul	Modulo di controllo d'ordine e di interruzione di fasi	Módulo de control de orden y de corte de fases
FS-0.1	Flow switch	Détecteur de débit d'eau (flow switch)	Strömungswächter (flow switch)	Sensore di portata di acqua (flussostato)	Detector de caudal de agua (flow switch)
FTC-1.1	Compressors magneto-thermal circuit breaker	Disjoncteurs magnétothermiques des compresseurs	Magnétothermische Schutzschalter der Verdichter	Disgiuntori magnetotermici dei compressori	Disyuntores magnetotérmicos de los compresores
FTC-1.2					
FTCC-0.1	Control circuit magneto-thermal circuit breaker	Disjoncteur magnétothermique du circuit de commande	Magnétothermischer Schutzschalter des Steuerkreises	Disgiuntore magnetotermico del circuito di comando	Disyuntor magnetotérmico del circuito de comando
FTEH-0.1	Magnetic breakers for heating elements (option) + additional contacts	Disjoncteurs magnétiques des éléments chauffants (option) + contact additionnels	Magnetische Schutzschalter der Heizelemente (Option) + Zusätzliche Kontakte	Interruttori magnetici degli elementi riscaldanti (optional) + Contatti aggiuntivi	Disyuntores magnéticos de los elementos calefactores (opcional) + contactos adicionales
FTEH-0.2					
FTPC-0.1	30mA circuit breaker for modem socket	Disjoncteur 30mA prise modem	30mA-Schutzschalter für Modembuchse	Interruttore 30mA per presa modem	Disyuntor de 30mA para la toma del módem
FTOF-1.1	Outdoor fans magneto-thermal circuit breaker	disjoncteur magnétothermique de la ventilation extérieure	Magnétothermischer Schutzschalter der externen Lüftung	Disgiuntore magnetotermico della ventilazione esterna	Disyuntor magnetotérmico de la ventilación exterior

	English	Français	Deutsch	Italiano	Español
	CONTROL AND REGULATION	SCHEMAS DE COMMANDE	STEUERPLÄNE	SCHEMI DI COMANDO	ESQUEMAS DE COMANDO
	DESCRIPTION	DESIGNATION	BEZEICHNUNG	DENOMINAZIONE	DESIGNACIÓN
FTM-0.1	Circuit breaker 2A modern socket	Disjoncteur 2A prise modern	Sicherungsautomat 2A Modernsteckdose	Interruttore 2A presa modern	Disyuntor 2A toma de modern
FTWP-0.1	Water pump motor magnetothermal circuit breaker	Disjoncteur magnétothermique du moteur de la pompe hydraulique	Magnetothermischer Schutzschalter des Wasserpumpenmotors	Disgiuntore magnetotermico del motore della pompa idraulica	Disyuntor magnetotérmico del motor de la bomba hidráulica
KA-0.2	Auxiliary line contactor	Relais auxiliaire	Hilfsrelais	Relé auxiliaire	Relé auxiliar
KC-1.1	Compressors power circuit contactor	contacteurs de puissance des compresseurs	Leistungsschütze der Verdichter	Contactori di potenza dei compressor	Contactores de potencia de los compresores
KEH-0.1	Power contactors for heating elements (option)	Contacteurs de puissance des éléments chauffants (option)	Leistungsschütze Heizelemente (Option)	Contactori di potenza degli elementi riscaldanti (optional)	Contactores de potencia de los elementos calefactores (opcional)
KOF-1.1	Outdoor fans power contactors	Contacteur de puissance des ventilations extérieures	Leistungsschütz der externen Lüftung	Contactore di potenza della ventilazione esterna	Contactor de potencia de la ventilación exterior
KOFHS-1.1	Outdoor fans power contactors	Contacteur de puissance grande vitesse des ventilations extérieures	Leistungsschütz der externen Lüftung	contactore di potenza della ventilazione esterna	contactor de potencia de la ventilación exterior
KOFLS-1.1	Outdoor fans power contactors	Contacteur de puissance petite vitesse des ventilations extérieures	Leistungsschütz der externen Lüftung	contactore di potenza della ventilazione esterna	contactor de potencia de la ventilación exterior
KWP-0.1	Water pump motor power contact	Contacteur de puissance du moteur de la pompe hydraulique	Leistungsschutz des Wasserpumpenmotors	contactore di potenza del motore della pompa idraulica	contactor de potencia del motor de la bomba hidráulica
LWT-0.1	Outlet water temperature probe	Sonde de température de sortie d'eau	Wasseraustritt-Temperaturfühler	sonda di temperatura di uscita dell'acqua	sonda de temperatura de salida de agua
MV-0.1	Fan of the electrical box	Ventilateur du coffret électrique	Ventilator für den Stromkasten	Ventilatore della scatola elettrica	Ventilador de la caja eléctrica
OAT-0.1	Outdoor temperature probe (air)	Sonde de température extérieure (air)	Außentemperaturfühler (Luft)	sonda di temperatura esterna (aria)	sonda de temperatura exterior (aire)
OCT-1.1	De-icing temperature probe	Sonde de température de batterie ailetée	Temperaturfühler der verrippten Batterie	sonda di temperatura della batteria alettata	sonda de temperatura de batería con aletas
PSW-0.1	Water low pressure switch (option)	Pressostat manque d'eau (option)	Wassermangel-Druckwächter (Option)	pressostato mancanza di acqua (opzionale)	presostato falta de agua (opcional)
PTHP-1.1	Pressure transducer (high-pressure)	Transducteur de pression (haute pression)	Druckwandler (Hochdruck)	trasduttore di pressione (alta pressione)	transductor de presión (alta presión)
PTLP-1.1	Pressure transducer (low pressure)	Transducteur de pression (basse pression)	Druckwandler (Niederdruck)	trasduttore di pressione (bassa pressione)	transductor de presión (baja presión)
QG-0.1	Main section switch	Interrupteur sectionneur principal	Hauptschalter	interruttore principale	interruptor sectionador principal
QGEH-0.1	Heating disconnect switch (optional)	Interrupteur sectionneur chauffage (option)	Trennschalter Heizung (Option)	Sezionatore di riscaldamento (opzionale)	Interruptor de desconexión de la calefacción (opcional)
RV-1.1	4-way cycle changeover valves (option)	Vanne d'inversion de cycle (option)	Umkehrzyklusventil (Option)	valvole di inversione di ciclo (opzionale)	válvula de inversión de ciclo (opcional)

	English	Français	Deutsch	Italiano	Español
	CONTROL AND REGULATION	SCHEMAS DE COMMANDE	STEUERPLÄNE	SCHEMI DI COMANDO	ESQUEMAS DE COMANDO
	DESCRIPTION	DESIGNATION	BEZEICHNUNG	DENOMINAZIONE	DESIGNACIÓN
SDN	Switch day / night (not supplied)	Interrupteur jour/nuit (non fourni)	Tag-/Nacht-Schalter (nicht mitgeliefert)	interruptore giorno/notte (non fornito)	interruptor día/noche (no suministrado)
SSTC-1.1	Soft Starter	Démarreurs «Soft Starter»	Anlasser «Soft Starter»	motorini di avviamento «Soft Starter»	Motor de arranque «Soft Starter»
SSTC-1.2	Switch winter / summer (not supplied)	Interrupteur hiver/été (non-fourni)	Winter/Sommer-Schalter	interruttore inverno /estate (non fornito)	interruptor invierno/verano (no suministrado)
SWS	Switch winter / summer (not supplied)	Interrupteur hiver/été (non-fourni)	Winter/Sommer-Schalter	interruttore inverno /estate (non fornito)	interruptor invierno/verano (no suministrado)
T-0.1	Transformer 230V/24V-63VA	Transformateur 230V/24V-63VA	Transformator 230V/24V-63VA	Trasformatore 230V/24V-63VA	Transformador 230V/24V-63VA
TEBF-0.1	Electric box thermostat	Thermostat du coffret électrique	Thermostat am Stromkasten	Termostato del quadro elettrico	Termostato del cuadro eléctrico
WFDWP-0.1	Three phase frequency variator of water pump motor	Variateur de fréquence triphasé du moteur de la pompe hydraulique	Drehstrom-Frequenzrichter der Wasserpumpenmotors	Variatore di frequenza trifase del motore della pompa idraulica	Variador de frecuencia trifásico del motor de la bomba hidráulica
WP-0.1	Water pump	Pompe hydraulique	Wasserpumpe	Pompa idraulica	Pomba hidráulica
WP-0.2	Water pump	Pompe hydraulique	Wasserpumpe	Pompa idraulica	Pomba hidráulica
X	Phase distributor	répartiteur de phases	Phasenverteiler	distributore di fase	distribuidor de fase

SYSAQUA R32 50 - 60

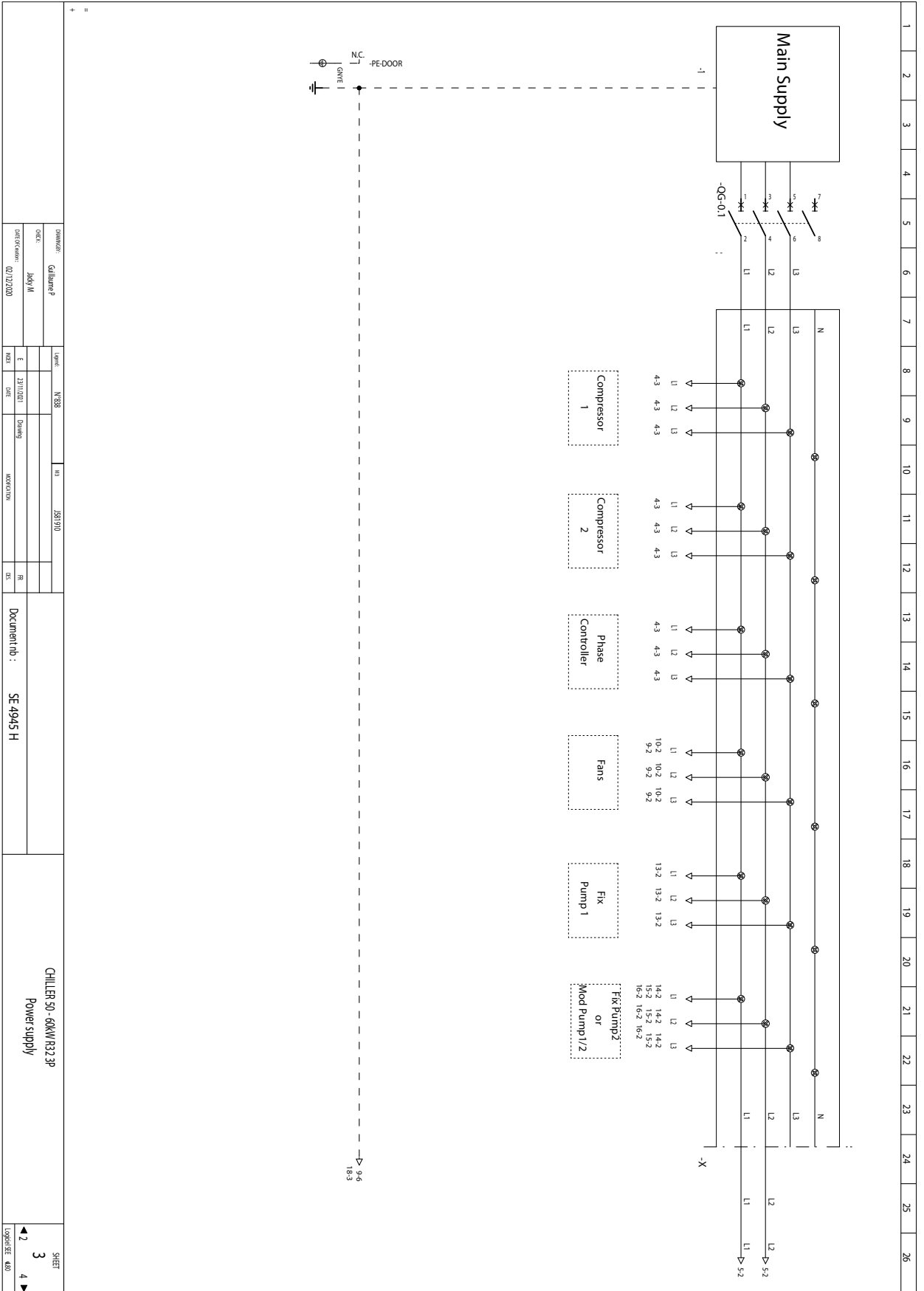

OWNER:	Galbani P	Level:	NSB	NO	2501910
CLIENT:	Jacky M	E	23/11/2021	Drawing	
DATE/REVISED:	02/12/2020	NOI	GME	MODIFICATION	
		RS	DS		
Document nb : SE 4945 H					
CHILLER 50 - 60kW R32 3P Power supply					
					SHEET
					3
					4
					LOP/SEE 480

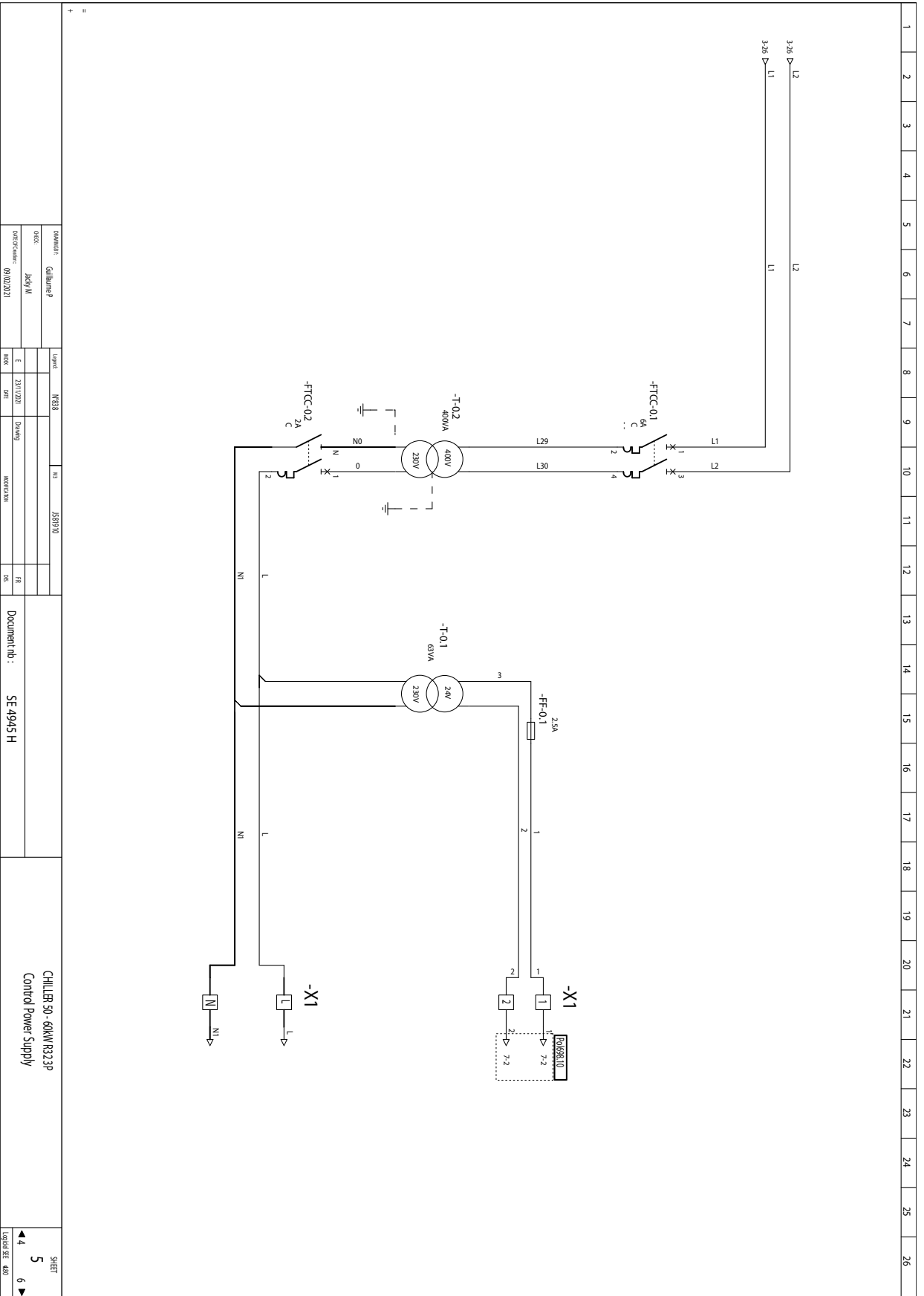

Project	MS88	no.	558910
Client	Calbimac P	Contract	CHILLER 50 - 60kW R32 3P
Author	Jacky M	Revision	Control Power Supply
Date	23/11/2011	Scale	
Drawn by	Shirley	Material	
Check		Doc. no.	SE 4945 H

Document no : SE 4945 H

CHILLER 50 - 60kW R32 3P
Control Power Supply

1
2
3
4
5
6
7
8
9
10
11
12
13
14
15
16
17
18
19
20
21
22
23
24
25
26

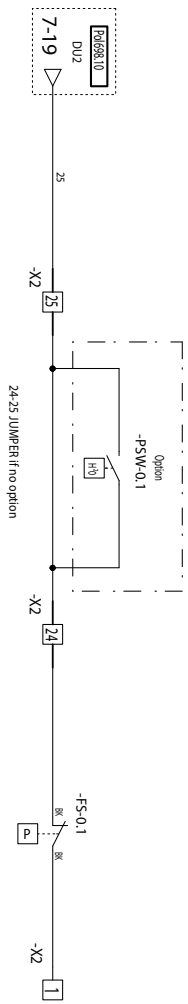

DRAWN BY: Galland P DATE: July 2011 PROJECT CODE: 00172000		SCALE: N:88 DATE: 18/07/2012 CHECK: 23/11/2011		NO: 383910 REVISION: 9 DATE: 02/		AQA TAILLE 70 DOCUMENT ID: SE 4945 H		CHILLERS 50 - 60kW/132.3P Hydraulic fault chain		SHEET 6 TOTAL SHEETS: 7	
--	--	--	--	--	--	---	--	--	--	----------------------------	--

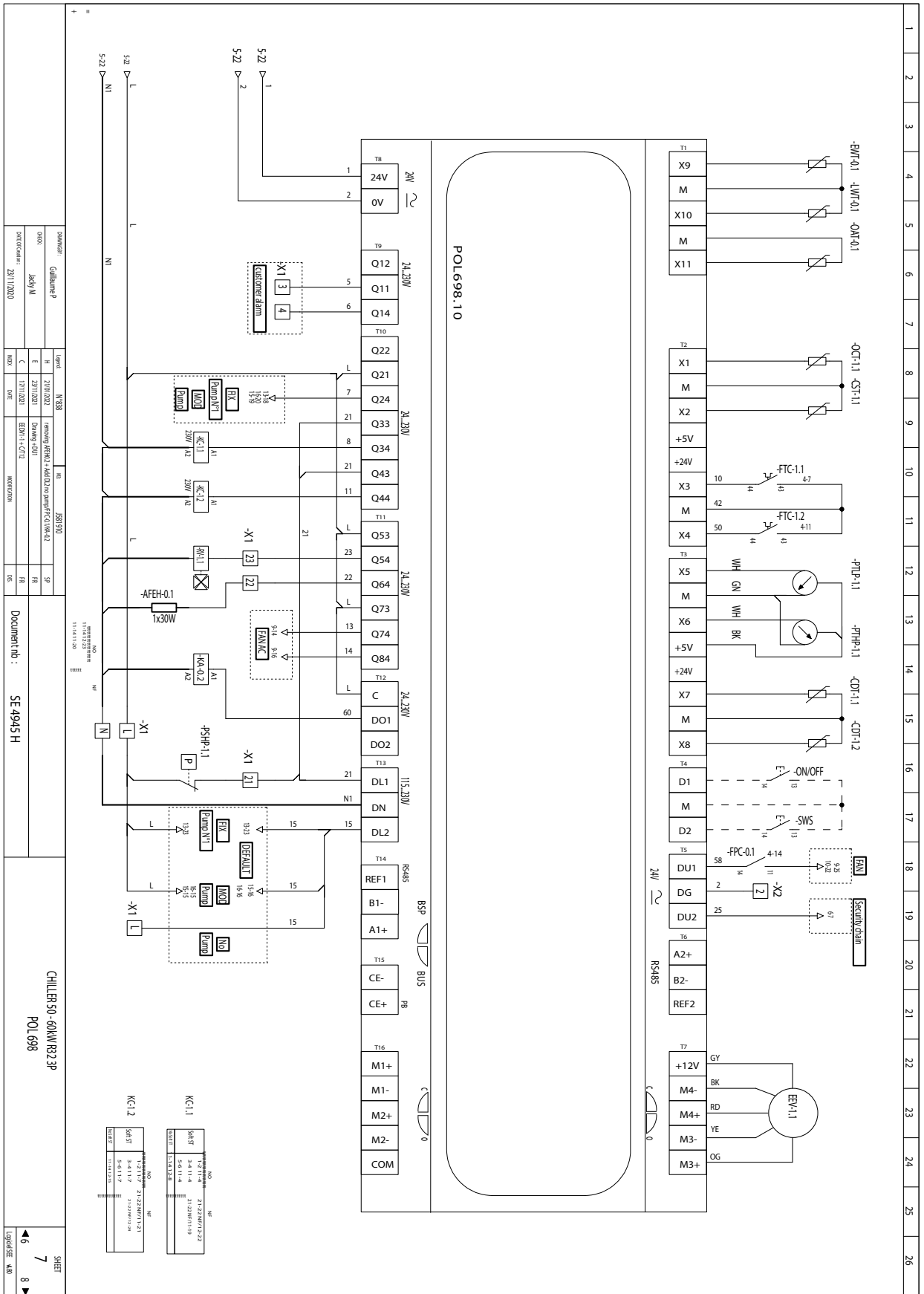

Brand	Gulburne P
Model	JK60W
Serial	231112000

Unit	N388
Year	2020
Location	Building 2011
Manufacturer	RSB11-CT13
Model	RSB11-CT13

Document no.	SE 4945 H
--------------	-----------

CHILLER 50-60kW R32 3P
POL 698

SHEET	7
OF	8
DATE	2023/05/18

POWER

COMMAND

ELEC.CHAIN

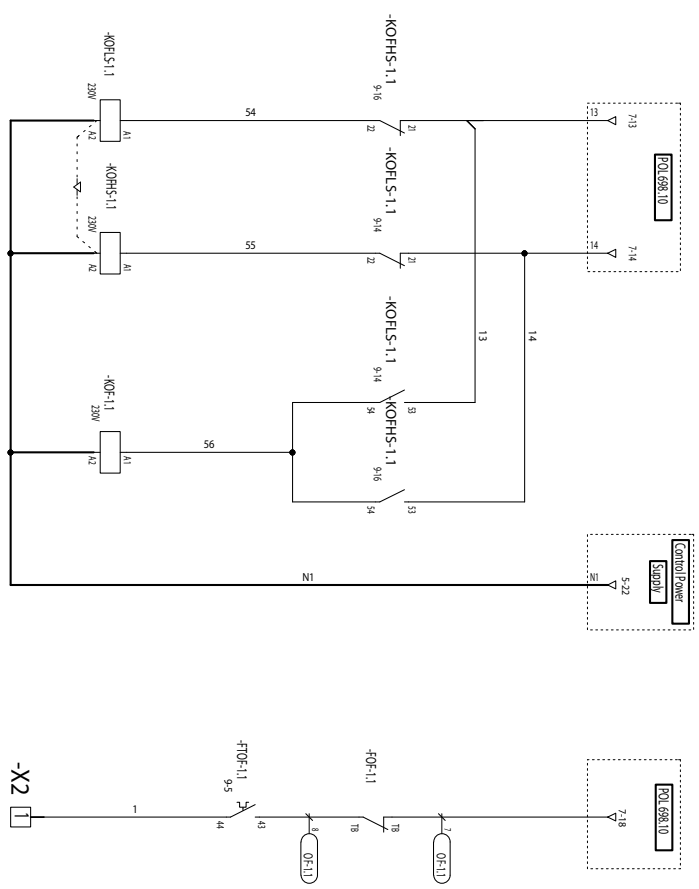
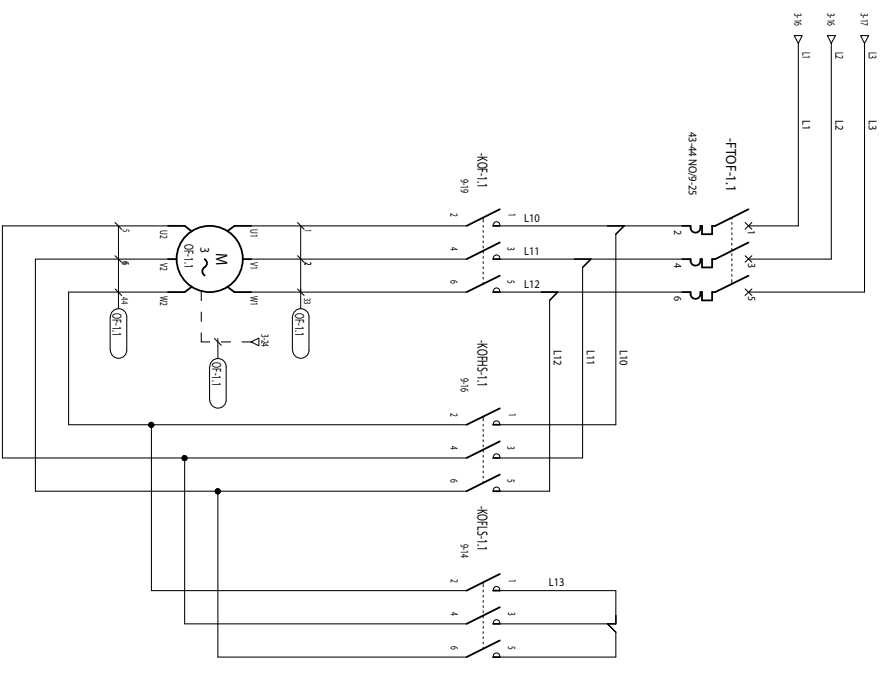

NO	REV	DESCRIPTION	DATE
1	1	INITIAL DESIGN	21/12/2010
2	2	REVISION	12/08/2011
3	3	REVISION	12/08/2011
4	4	REVISION	12/08/2011
5	5	REVISION	12/08/2011

PROJEKTANT	Qualime P	Legende	N388	NO	581910	SP	CHILLER-50-60kW R323P Fans AC	SHEET 9
CLIENT	SAE M	DATE	21/12/2010	REV		RE		
PROJEKT	SAE M	DATE	21/12/2010	REV		RE		
PROJEKT	SAE M	DATE	21/12/2010	REV		RE		
PROJEKTANT	Qualime P	Legende	N388	NO	581910	SP	CHILLER-50-60kW R323P Fans AC	SHEET 9
CLIENT	SAE M	DATE	21/12/2010	REV		RE		
PROJEKT	SAE M	DATE	21/12/2010	REV		RE		
PROJEKT	SAE M	DATE	21/12/2010	REV		RE		

1	2	3	4	5	6	7	8	9	10	11	12	13	14	15	16	17	18	19	20	21	22	23	24	25	26
---	---	---	---	---	---	---	---	---	----	----	----	----	----	----	----	----	----	----	----	----	----	----	----	----	----

POWER

ELECTRICAL FAULT CHAIN

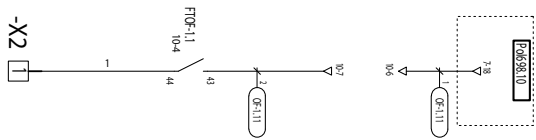
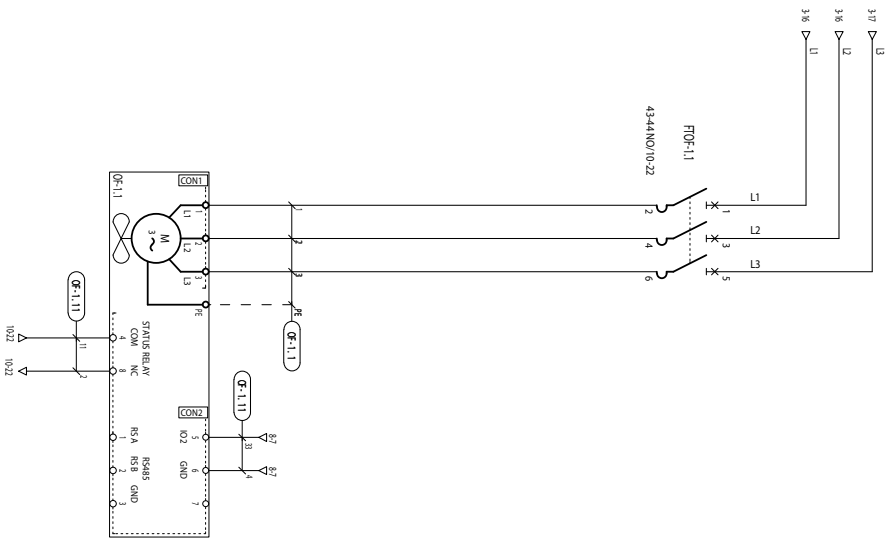

Dimension: Gullburne P Title: Lady M Date of Issue: 18/11/2020		Unit: NS38 No: 259790		Date: 21/02/22 Drawn: 23/11/2021 Date: 05/		Description: Change Electrical Drawings Drawing ID: MOD00000		Document no: SE-4945 H		CHILLER-50-60kW R32 3P Fans EC - HPP SLN		SHEET 10 9 11	
--	--	--------------------------	--	--	--	---	--	------------------------	--	---	--	---------------------	--

POWER

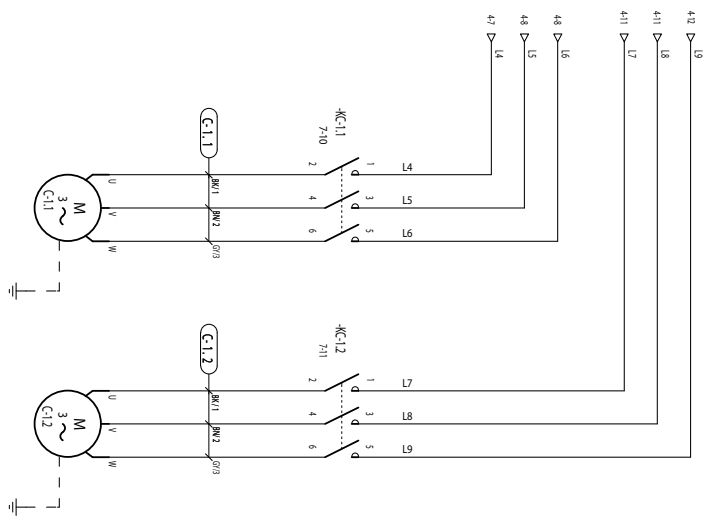

COMMAND

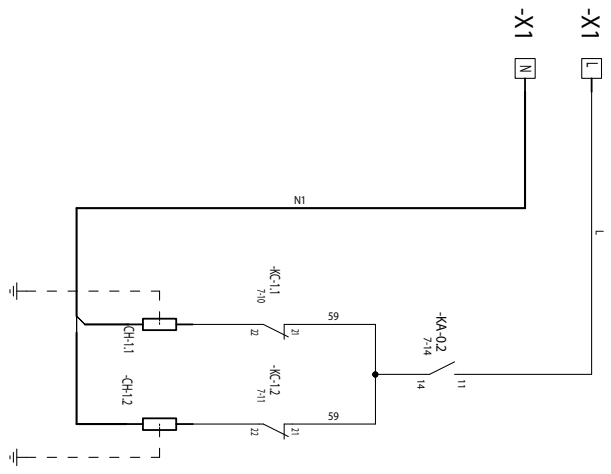

Dimensione C-1.03 J609 M Data di Comm.: 04/12/2020	Uscite H E S NCS	N888 21/02/2021 21/12/2021 07/09/2021 01/12/2020	4640A42 4640A42 4640A42 4640A42	141 141 141 141	1589110 1589110 1589110 1589110	SP F8 GP GR	Document nb : SE 4945 H	CHILLER 50 - 60kW R32 3P Compressors Without Soft-Start	SHEET 11 12 400
---	------------------------------	--	--	--------------------------	--	----------------------	-------------------------	--	--------------------------

1 2 3 4 5 6 7 8 9 10 11 12 13 14 15 16 17 18 19 20 21 22 23 24 25 26

POWER

COMMAND

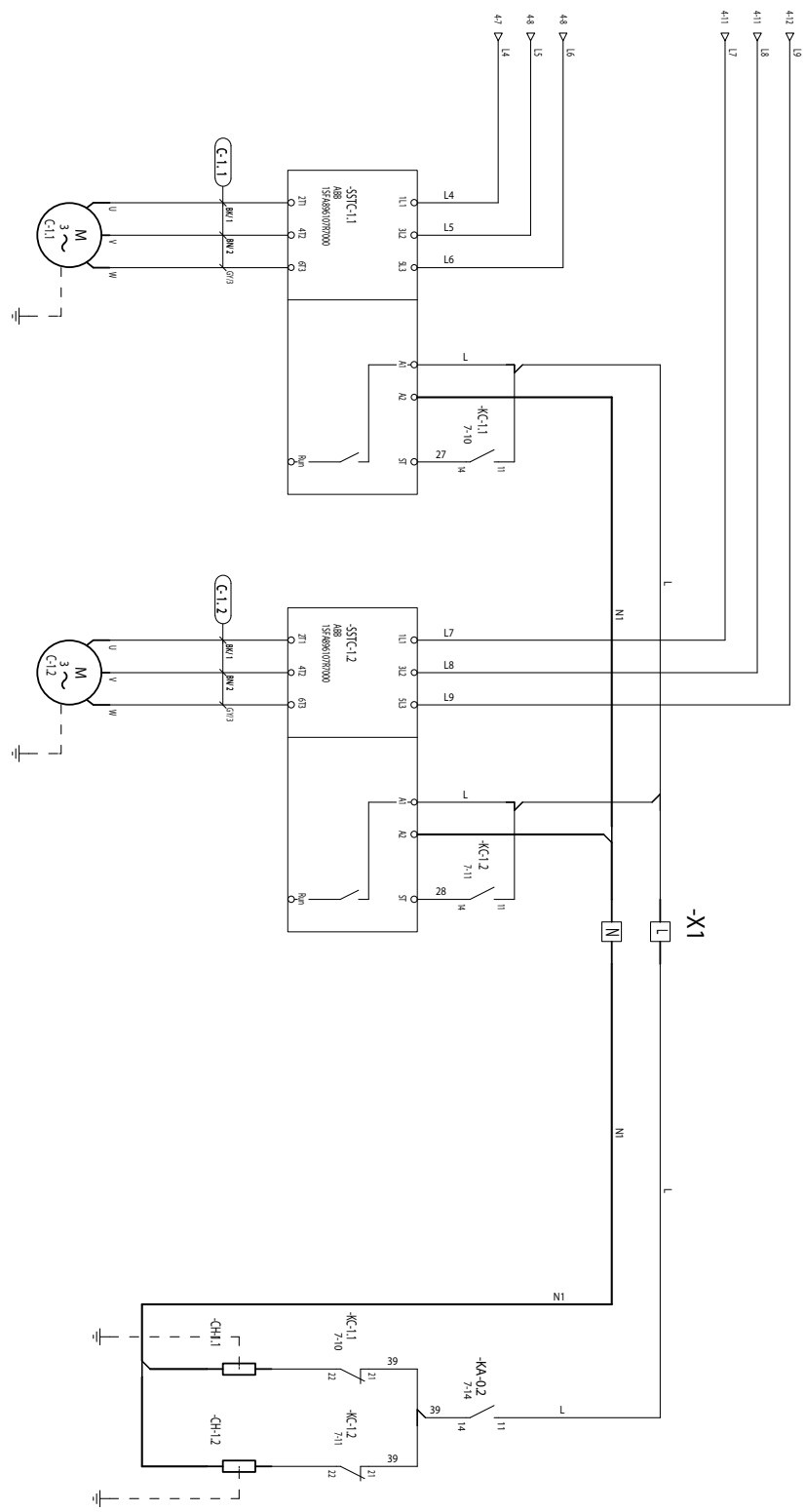

OWNER:	Colson P	OPER:	NESS	NO:	43	PROJECT NO:	J58910
DATE:	July 01	DATE:	21/02/2021	REV:	01	DESCRIPTION:	ADD IN Q1
DATE:	30/03/2021	DATE:	21/12/2021	REV:	02	DESCRIPTION:	removing M
		DATE:	07/09/2021	REV:	03	DESCRIPTION:	Modifying R32 liquid
		DATE:		REV:	04	DESCRIPTION:	MODIFICATION
Document nb :				SE 4945 H			
CHILLER-SD - 60kW R32 3P				Compressors With Soft Starter			
SHEET				12			
11				13			
TOP SHEET 480							

1 2 3 4 5 6 7 8 9 10 11 12 13 14 15 16 17 18 19 20 21 22 23 24 25 26

POWER

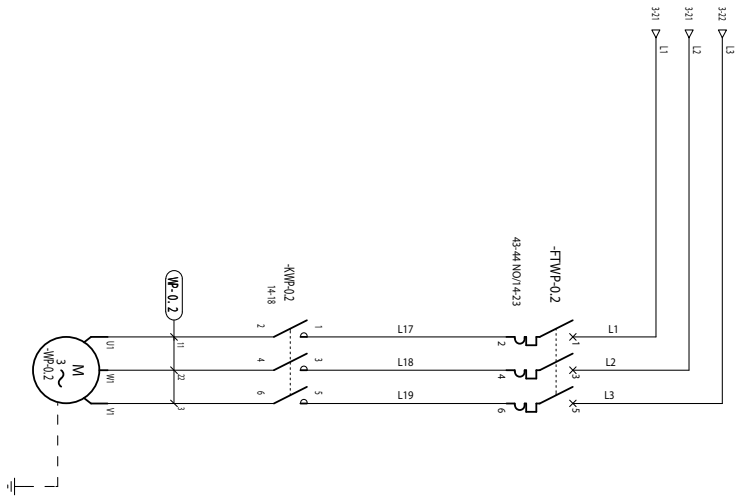

COMMAND

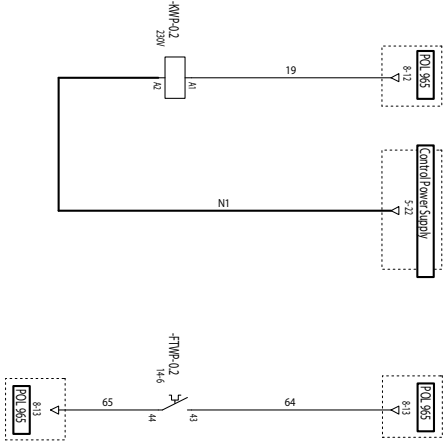

OWNER: Gallunep P	OPER: NCS	NO: JS8910	CHILLER-50-60kW R32 3P FIX Pump N°2	SHEET 14
DATE: 26/11/2020	DATE: 20/10/2022	DATE: 21/11/2021	Document nb: SE 4945 H	13
DATE: 26/11/2020	DATE: 21/11/2021	DATE: 21/11/2021	Document nb: SE 4945 H	15
DATE: 26/11/2020	DATE: 21/11/2021	DATE: 21/11/2021	Document nb: SE 4945 H	15

POWER

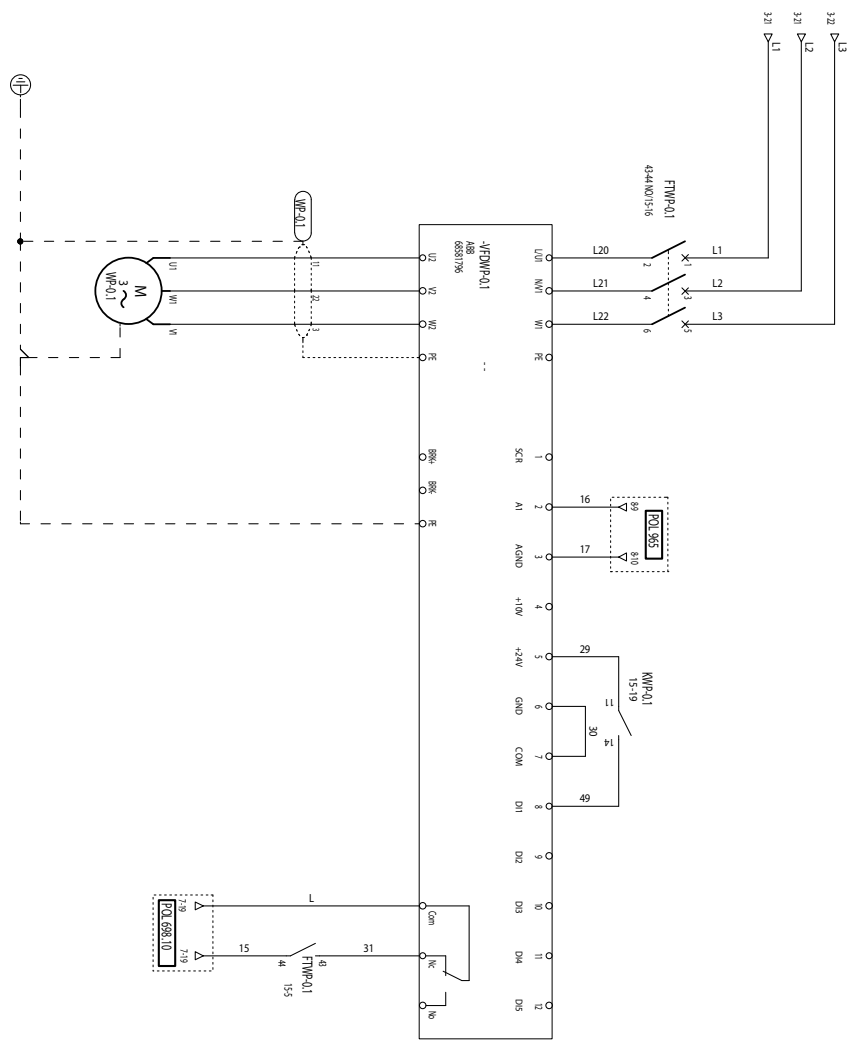

COMMAND

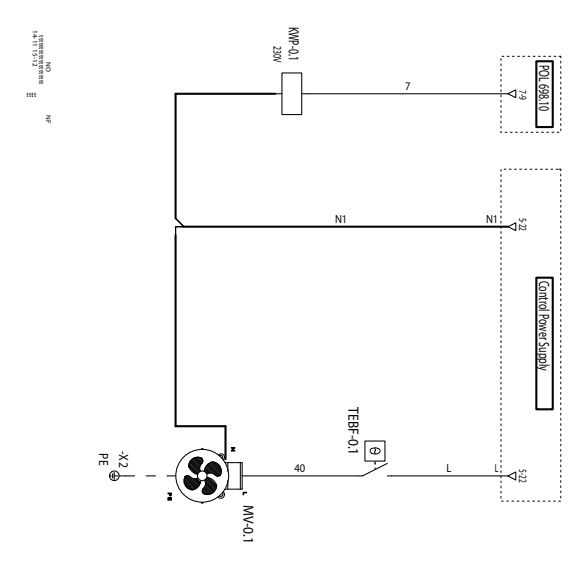

Designation	CHILLER-50 - 60kW/ R32 3P Modulating Pump N°1
Model	559310
Code	559310
Manufacturer	CHILLER-50 - 60kW/ R32 3P Modulating Pump N°1
Order Date	20/11/2020
Order Ref.	SE 4945 H
Sheet	15
Total Sheets	16
Scale	400

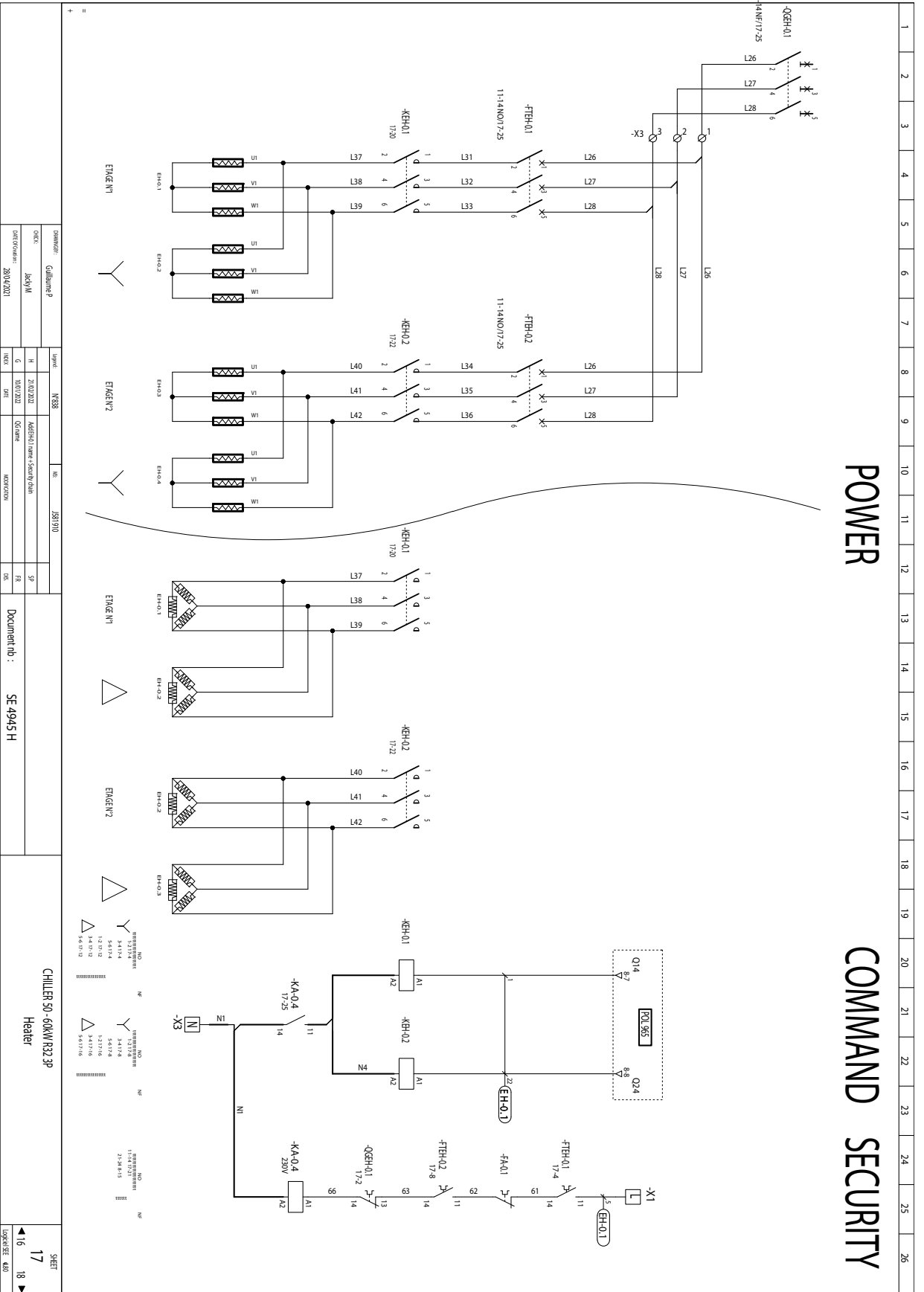

POWER

COMMAND SECURITY

OWNER:	GulfairerP	Unit:	N-88	NO.	J281710
DATE:	21/07/2022	REVISION:	01	DATE:	28/04/2021
DESIGNER:	JASVM	CHECKER:	MS	DATE:	28/04/2021

PROJECT:	MADHADI (MAM + SWAMY) DAN
NO.:	NO. 4945 H

CHILLER SO - 60KW R32 3P
Heater

APPENDIX / ANNEXE / ANLAGE / ALLEGATO / ANEXO

START UP FORM / FICHE DE MISE EN SERVICE

CUSTOMER INFORMATION:

Order number: Job name:

Contractor: Installation address:

Contact: ☎:

INSTALLER INFORMATION:

Company: Address:

Contact: ☎:

COMMISSIONING INFORMATION:

Company: Address:

Contact: ☎:

UNIT IDENTIFICATION:

	50	60	70	75	85	100	115	130	150	170
SYSAQUA R32 L										
SYSAQUA R32 H										

Unit serial number:

	YES	NO		YES	NO		YES	NO
Simple pump	<input type="checkbox"/>	<input type="checkbox"/>	All seasons kit	<input type="checkbox"/>	<input type="checkbox"/>	XLN	<input type="checkbox"/>	<input type="checkbox"/>
Double pump	<input type="checkbox"/>	<input type="checkbox"/>	HPF	<input type="checkbox"/>	<input type="checkbox"/>	Soft Starter	<input type="checkbox"/>	<input type="checkbox"/>
Buffer tank	<input type="checkbox"/>	<input type="checkbox"/>						

Compressor 1 serial number: Compressor 2 serial number:

INSTALLATION CHECKING:

	YES	NO		YES	NO
Recommended free clearance	<input type="checkbox"/>	<input type="checkbox"/>	Water connection, cleaning, rinsing, air bleed	<input type="checkbox"/>	<input type="checkbox"/>
Level installation	<input type="checkbox"/>	<input type="checkbox"/>	Anti-frost protection of the water loop	<input type="checkbox"/>	<input type="checkbox"/>
Unit correctly mounted on supplied dampers	<input type="checkbox"/>	<input type="checkbox"/>	Installation thermal load reaches at least 50%	<input type="checkbox"/>	<input type="checkbox"/>
Power supply compatible with unit specifications	<input type="checkbox"/>	<input type="checkbox"/>	Mesh filter at the inlet of the unit	<input type="checkbox"/>	<input type="checkbox"/>
State-of-art power cable section and wiring to the unit	<input type="checkbox"/>	<input type="checkbox"/>	Minimum water flowrate available	<input type="checkbox"/>	<input type="checkbox"/>
Ground cable is wired	<input type="checkbox"/>	<input type="checkbox"/>	Flowswitch cut-out checked	<input type="checkbox"/>	<input type="checkbox"/>
Main electrical protection suits the unit	<input type="checkbox"/>	<input type="checkbox"/>	Crankcases heaters are energized since 12 hours	<input type="checkbox"/>	<input type="checkbox"/>
All electrical connections are correctly tightened	<input type="checkbox"/>	<input type="checkbox"/>		<input type="checkbox"/>	<input type="checkbox"/>
Ground continuity on all pipes	<input type="checkbox"/>	<input type="checkbox"/>		<input type="checkbox"/>	<input type="checkbox"/>

OBSERVATIONS:

.....

.....

.....

.....

.....

.....

.....

.....

.....

.....

APPENDIX / ANNEXE / ANLAGE / ALLEGATO / ANEXO

INSTALLATION MEASUREMENTS:

Ambient temperature: Ambient humidity:

ELECTRICAL MEASUREMENTS:

Voltage L1-N: Voltage L1-L2:

Voltage L1-L3: Voltage L2-L3:

Voltage unbalance less than 2 % YES NO

Never start the unit if the voltage unbalance is over 2 %. Please, contact your electricity supplier for help.

	VOLTAGE			NOMINAL CURRENT		
	L1-L2	L1-L3	L2-L3	L1	L2	L3
Comp. 1						
Comp. 2						
Fan 1						
Fan 2						
Pump 1						
Pump 2						

THERMODYNAMICS MEASUREMENTS:

% of capacity		%	%	%	%
Evaporating pressure		bar	bar	bar	bar
Evaporating temperature		°C	°C	°C	°C
Suction temperature		°C	°C	°C	°C
Condensing pressure		bar	bar	bar	bar
Condensing temperature		°C	°C	°C	°C
Liquid line temperature		°C	°C	°C	°C
Discharge temperature		°C	°C	°C	°C
High pressure switch cut-out		bar	bar	bar	bar

HYDRAULICS MEASUREMENTS:

Inlet temperature	°C	Vmax (VARIABLE PRIMARY FLOW)	%
Outlet temperature	°C	Vmin (VARIABLE PRIMARY FLOW)	%
BPHE inlet pressure	kPa	Vstdby (VARIABLE PRIMARY FLOW)	%
BPHE outlet pressure	kPa	Water pressure setpoint	bar
Glycol type & contents	%		

REMARKS:

.....

The installer certifies that the system has been installed in accordance with the design requirements, and reports that the safety and control devices have been adjusted in accordance with the manufacturer's recommendations.

Date:
TECNICIAN:
Name:
Sign-in:

Date:
CLIENT:
Name:
Sign-in:

As part of our ongoing product improvement programme, our products are subject to change without prior notice. Non contractual photos.

Systemair AC SAS

Route de Verneuil
27570 Tillières-sur-Avre
FRANCE

☎ : +33 (0)2 32 60 61 00

📠 : +33 (0)2 32 32 55 13



J581917GB

IOM AQA R32 01-N-3GB
Part number : J581917GB
Supersedes : IOM AQA R32 01-N-2GB