

Installation and maintenance manual
Manuel d'installation et de maintenance
Installations- und Wartungshandbuch
Manuale di installazione e di manutenzione
Manual de instalación y de mantenimiento

SyScrew 300-1400

Air CO/TR

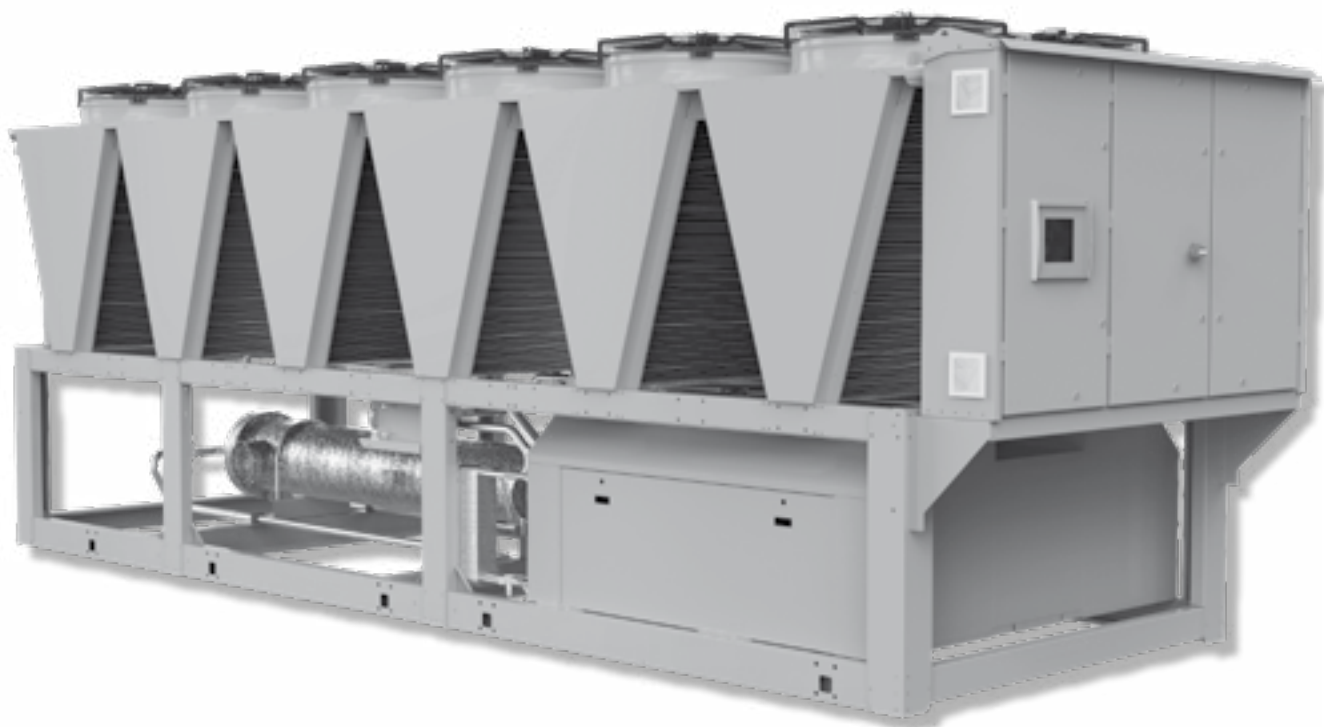

English

Français

Deutsch

Italiano

Español



295
↓
1395 kW



Air Cooled Water Chillers with Screw Compressors
Refroidisseurs de liquide à condensation par air avec compresseurs à vis
Luftgekühlte Wasserkühler mit Schraubenkompressoren
Refrigeratori d'Acqua Raffreddati ad Aria con compressori a vite
Enfriadores de Agua Condensadas con Aire con compresores a tornillo

Part number / Code / Code / Codice / Código: **363112/G**
Supersedes / Annule et remplace / Annulliert und ersetzt / Annulla e sostituisce /
Anula y sustituye: **363112/F**
Notified Body / Organisme Notifié / Benannte Zertifizierungsstelle /
Organismo Notificato / Organismo Notificado N°. **0425**



Table of Contents

1 - FOREWORD

1.1 Introduction.....	2
1.2 Warranty.....	2
1.3 Emergency stop/Normal stop.....	2
1.4 An introduction to this manual.....	2

2 - SAFETY

2.1 Foreword.....	3
2.2 Definitions.....	4
2.3 Access to the unit.....	4
2.4 General precautions.....	4
2.5 Precautions against residual risks.....	4
2.6 Precautions during maintenance operations.....	5
2.7 Safety labels.....	6 & 7
2.8 Safety regulations.....	8 to 10

3 - TRANSPORT, LIFTING AND POSITIONING

3.1 Inspection.....	11
3.2 Lifting.....	11
3.3 Anchoring.....	12
3.4 Storage.....	12

4 - INSTALLATION

4.1 Positioning of the unit.....	13
4.2 Spring isolator installation.....	13
4.3 External hydraulic circuit.....	14 & 15
4.4 Hydraulic connections.....	15
4.5 Power supply.....	16
4.6 Electrical connections.....	17
4.7 Connection of water temperature sensors (on shell and tube evaporator).....	18

5 - START-UP

5.1 Preliminary check.....	19
5.2 Start-up.....	19
5.3 Checking the operation.....	19
5.4 Delivery to the customer.....	19

6 - CONTROL

6.1 Display.....	21
6.2 Setpoint.....	23
6.3 Protection and Safety Equipment.....	24
6.4 HPF version configuration.....	25

7 - PRODUCT DESCRIPTION

7.1 Introduction.....	26
7.2 General specifications.....	26
7.3 Compressors.....	26
7.4 Refrigeration circuits.....	26
7.5 Water heat exchanger.....	27
7.6 Air heat exchanger.....	27
7.7 Fans.....	27
7.8 Electrical power supply and control system.....	27
7.9 Accessories.....	27

8 - TECHNICAL DATA

8.1 Pressure drops.....	30
8.2 Technical data.....	31 to 42
8.3 Unit electrical data.....	43 to 45
8.4 Hydraulic Features.....	46 to 49
8.5 Position of shock adsorbers and weight distribution on supports.....	50
8.6 Dimensional Drawings.....	51 to 58
8.7 Service spaces.....	59

9 - MAINTENANCE

9.1 General requirements.....	60
9.2 Planned maintenance.....	60
9.3 Refrigerant charge.....	61
9.4 Compressor.....	61
9.5 Condenser.....	61
9.6 Fans.....	61
9.7 Dehydrating filter.....	61
9.8 Sight glass.....	62
9.9 Electronic expansion valve.....	62
9.10 Evaporator.....	62

10 - TROUBLESHOOTING..... 63

11 - SPARE PARTS

11.1 Spare part list.....	64
11.2 Oil for compressors.....	64
11.3 Wiring diagrams.....	64

12 - DISMANTLING, DEMOLITION AND SCRAPPING

12.1 Generalities.....	65
12.2 RAEE Directive.....	65

1 - Foreword

1.1 Introduction

Units, manufactured to state-of-the-art design and implementation standards, ensure top performance, reliability and fitness to any type of air-conditioning systems.

These units are designed for cooling water or glycoled water (and for water heating in heat pump models) and are unfit for any purposes other than those specified in this manual.

This manual includes all the information required for a proper installation of the units, as well as the relevant operating and maintenance instructions.

It is therefore recommended to read this manual carefully before installation or any operation on the machine. The chiller installation and maintenance must be carried out by skilled personnel only (where possible, by one of Authorised Service Centers).

The manufacturer may not be held liable for any damage to people or property caused by improper installation, start-up and/or improper use of the unit and/or failure to implement the procedures and instructions included in this manual.

1.2 Warranty

These units are delivered complete, tested and ready for being operated. Any form of warranty will become null and void in the event that the appliance is modified without manufacturer's preliminary written authorisation.

This warranty shall apply providing that the installation instructions have been complied with (either issued by manufacturer, or deriving from the current practice), and the Form 1 ("Start-up") has been filled-in and mailed to manufacturer (attn. After-Sales Service).

In order for this warranty to be valid, the following conditions shall be met:

- The machine must be operated only by skilled personnel from Authorised After-Sales Service.
- Maintenance must be performed only by skilled personnel - from one of Authorised After-Sales Centers.
- Use only original spare parts.
- Carry out all the planned maintenance provided for by this manual in a timely and proper way.

Failure to comply with any of these conditions will automatically void the warranty.

1.3 Emergency stop / Normal stop

The emergency stop of the unit can be enabled using the master switch on the control panel (move down the lever).





For a normal stop, press the relevant push-buttons.

To restart the appliance, follow the procedure detailed in this manual.

1.4 An introduction to the manual

For safety reasons, it is imperative to follow the instructions given in this manual. In case of any damage caused by non-compliance with these instructions, the warranty will immediately become null and void.

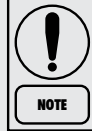
Conventions used throughout the manual:

	The Danger sign recalls your attention to a certain procedure or practice which, if not followed, may result in serious damage to people and property.
	The Warning sign precedes those procedures that, if not followed, may result in serious damage to the appliance.
	The Notes contain important observations.
	The Useful Tips provide valuable information that optimises the efficiency of the appliance.

This manual and its contents, as well as the documentation which accompanies the unit, are and remain the property of manufacturer, which reserves any and all rights thereon. This manual may not be copied, in whole or in part, without manufacturer's written authorization.

2 - Safety

2.1 Foreword

These units must be installed in conformity with the provisions of Machinery Directive 2006/42/EC, Pressure Equipment Directive 2014/68/EU, Electromagnetic Compability Directive 2014/30/EU, as well as with other regulations applicable in the country of installation. If these provisions are not complied with, the unit must not be operated.

	<p>The unit must be grounded, and no installation and/or maintenance operations may be carried out before deenergising the electrical panel of the unit.</p>
---	--

Failure to respect the safety measures mentioned above may result in electrocution hazard and fire in the presence of any short-circuits.

	<p>Inside the heat exchangers, the compressors and the refrigeration lines, this unit contains liquid and gaseous refrigerant under pressure. The release of this refrigerant may be dangerous and cause injuries.</p>
---	--

	<p>The units are not designed to be operated with natural refrigerants, such as hydrocarbons. Manufacturer may not be held liable for any problems deriving from the replacement of original refrigerant or the introduction of hydrocarbons.</p>
---	---

Units are designed and manufactured according to the requirements of European Standard PED 2014/68/EU (pressure vessels directive).

- The used refrigerants are included in group II (non-hazardous fluids).
- The maximum working pressure values are mentioned on the unit's data plate.
- Suitable safety devices (pressure switches and safety valves) have been provided, to prevent any anomalous overpressure inside the plant.
- The vents of the safety valves are positioned and oriented in such a way as to reduce the risk of contact with the operator, in the event that the valve is operated. Anyway, the installer will convey the discharge of the valves far from the unit.
- Dedicated guards (removable panels with tools) and danger signs indicate the presence of hot pipes or components (high surface temperature).

	<p>The guards of the fans (only for units provided with air heat exchangers) must be always mounted and must never be removed before de-energising the appliance.</p>
---	---

	<p>It is the User's responsibility to ensure that the unit is fit for the conditions of intended use and that both installation and maintenance are carried out by experienced personnel, capable of respecting all the recommendations provided by this manual.</p> <p>It is important that the unit is adequately supported, as detailed in this manual. Non-compliance with these recommendations may create hazardous situations for the personnel.</p>
---	---

	<p>The unit must rest on a base which meets the characteristics specified in this manual; a base with inadequate characteristics is likely to become a source of serious injury to the personnel.</p>
---	---

	<p>The unit has not been design to withstand loads and/or stress that may be transmitted by adjacent units, piping and/or structures.</p> <p>Each external load or stress transmitted to the unit may break or cause breakdowns in the unit's structure, as well as serious dangers to people. In these cases, any form of warranty will automatically become null and void.</p>
---	--

	<p>The packaging material must not be disposed of in the surrounding environment or burnt.</p>
---	--

2 - Safety (continued)

2.2 Definitions

OWNER: means the legal representative of the company, body or individual who owns the plant where unit has been installed; he/she has the responsibility of making sure that all the safety regulations specified in this manual are complied with, along with the national laws in force.

INSTALLER: means the legal representative of the company who has been given by the owner the job of positioning and performing the hydraulic, electric and other connections of unit to the plant; he/she is responsible for handling and properly installing the appliance, as specified in this manual and according to the national regulations in force.

OPERATOR: means a person authorised by the owner to do on unit all the regulation and control operations expressly described in this manual, that must be strictly complied with, without exceeding the scope of the tasks entrusted to him.

ENGINEER: means a person authorised directly by manufacturer or, in all EC countries, excluding Italy, under his full responsibility, by the distributor of product, to perform any routine and extraordinary maintenance operations, as well as any regulation, control, servicing operations and the replacement of pieces, as may be necessary during the life of the unit.

2.3 Access to the unit

The unit must be placed in an area which can be accessed also by OPERATORS and ENGINEERS; otherwise the unit must be surrounded by a fence at not less than 2 meters from the external surface of the machine.

OPERATORS and ENGINEERS must enter the fenced area only after wearing suitable clothing (safety shoes, gloves, helmet etc.). The INSTALLER personnel or any other visitor must always be accompanied by an OPERATOR.

For no reason shall any unauthorised personnel be left alone in contact with the unit.

2.4 General precautions

The OPERATOR must simply use the controls of the unit; he must not open any panel, other than the one providing access to the control module.

The INSTALLER must simply work on the connections between plant and machine; he must not open any panels of the machine and he must not enable any control.

When you approach or work on the unit, follow the precautions listed below:

- do not wear loose clothing or jewellery or any other accessory that may be caught in moving parts
- wear suitable personal protective equipment (gloves, goggles etc.) when you have to work in the presence of free flames (welding operations) or with compressed air
- if the unit is placed in a closed room, wear ear protection devices
- cut off connecting pipes, drain them in order to balance the pressure to the atmospheric value before disconnecting them,

disassemble connections, filters, joints or other line items

- do not use your hands to check for any pressure drops
- use tools in a good state of repair; be sure to have understood the instructions before using them
- be sure to have removed all tools, electrical cables and any other objects before closing and starting the unit again

2.5 Precautions against residual risks

Prevention of residual risks caused by the control system

- be sure to have perfectly understood the operating instructions before carrying out any operation on the control panel
- when you have to work on the control panel, keep always the operating instructions within reach
- start the unit only after you have checked its perfect connection to the plant
- promptly inform the ENGINEER about any alarm involving the unit
- do not reset manual restoration alarms unless you have identified and removed their cause

Prevention of residual mechanical risks

- install the unit according to the instructions provided in this manual
- carry out all the periodical maintenance operations prescribed by this manual
- wear a protective helmet before accessing the interior of the unit
- before opening any panelling of the machine, make sure that it is secured to it by hinges
- do not touch air condensation coils without wearing protective gloves
- do not remove the guards from moving elements while the unit is running
- check the correct position of the moving elements' guards before restarting the unit

Prevention of residual electrical risks

- connect the unit to the mains according to the instructions provided in this manual
- periodically carry out all the maintenance operations specified by this manual
- disconnect the unit from the mains by the external disconnecting switch before opening the electrical board
- check the proper grounding of the unit before start-up
- check all the electrical connections, the connecting cables, and in particular the insulation; replace worn or damaged cables

2 - Safety (continued)

- periodically check the board's internal wiring
- do not use cables having an inadequate section or flying connections, even for limited periods of time or in an emergency

Prevention of other residual risks

- make sure that the connections to the unit conform to the instructions provided in this manual and on the unit's panelling
- if you have to disassemble a piece, make sure that it has been properly mounted again before restarting the unit
- do not touch the delivery pipes from the compressor, the compressor and any other piping or component inside the machine before wearing protective gloves
- keep a fire extinguisher for electrical appliances near the machine
- on the units installed indoor, connect the safety valve of the refrigeration circuit to a piping network that can channel any overflowing refrigerant outside
- remove and leak of fluid inside and outside the unit
- collect the waste liquids and dry any oil spillage
- periodically clean the compressor compartment, to remove any fouling
- do not store flammable liquids near the unit
- do not disperse the refrigerant and the lubricating oil into the environment
- weld only empty pipes; do not approach flames or other sources of heat to refrigerant pipes
- do not bend/hit pipes containing fluids under pressure

2.6 Precautions during maintenance operations

Maintenance operations can be carried out by authorised technicians only.

Before performing any maintenance operations:

- disconnect the unit from the mains with the external disconnecting switch

- place a warning sign "do not turn on - maintenance in progress" on the external disconnecting switch
- make sure that on-off remote controls are inhibited
- wear suitable personal protective equipment (helmet, safety gloves, goggles and shoes etc.)

To carry out any measurements or checks which require the activation of the machine:

- work with the electrical board open only for the necessary time
- close the electrical board as soon as the measurement or check has been completed
- for outdoor units, do not carry out any operations in the presence of dangerous climatic conditions (rain, snow, mist etc.)

The following precautions must be always adopted:

- do not scatter the fluids of the refrigeration circuit in the surrounding environment
- when replacing an eprom or electronic cards, use always suitable devices (extractor, antistatic bracelet, etc.)
- to replace a compressor, the evaporator, the condensing coils or any other weighty element, make sure that the lifting equipment is consistent with the weight to be lifted
- in air units with independent compressor compartment, do not access the fan compartment unless you have disconnected the machine by the disconnecting switch on the board and you have placed a warning sign "do not turn on - maintenance in progress"
- contact manufacturer for any modifications to the refrigeration, hydraulic or wiring diagram of the unit, as well as to its control logics
- contact manufacturer if it is necessary to perform very difficult disassembly and assembly operations
- use only original spare parts purchased directly from manufacturer or the official retailers of the companies on the recommended spare parts list
- contact manufacturer if it is necessary to handle the unit one year after its positioning on site or if you wish to dismantle it.

2 - Safety (continued)

2.7 Safety labels

Identification of the refrigerant - External door						
Electrical warning - Adjacent to the master switch						
<table border="1"> <tr> <td style="text-align: center;"> </td> <td style="text-align: center;"> ATTENZIONE ! Prima di aprire togliere tensione </td> <td style="text-align: center;"> ATTENTION ! Enlever l'alimentation électrique avant d'ouvrir </td> </tr> <tr> <td style="text-align: center;"> ACHTUNG ! Vor öffnen des gehäuses hauptschalter ausschalten </td> <td style="text-align: center;"> CAUTION ! Disconnect electrical supply before opening </td> <td style="text-align: center;"> ATENCIÓN ! Cortar la corriente antes de abrir el aparato </td> </tr> </table>		ATTENZIONE ! Prima di aprire togliere tensione	ATTENTION ! Enlever l'alimentation électrique avant d'ouvrir	ACHTUNG ! Vor öffnen des gehäuses hauptschalter ausschalten	CAUTION ! Disconnect electrical supply before opening	ATENCIÓN ! Cortar la corriente antes de abrir el aparato
	ATTENZIONE ! Prima di aprire togliere tensione	ATTENTION ! Enlever l'alimentation électrique avant d'ouvrir				
ACHTUNG ! Vor öffnen des gehäuses hauptschalter ausschalten	CAUTION ! Disconnect electrical supply before opening	ATENCIÓN ! Cortar la corriente antes de abrir el aparato				
Read the instruction on the electrical board						
On the compressor box						
<table border="1"> <tr> <td style="text-align: center;"> </td> <td style="text-align: center;"> DO NOT OPEN THE PANEL WHILE UNIT IS RUNNING </td> </tr> <tr> <td style="text-align: center;"> </td> <td style="text-align: center;"> WARNING </td> </tr> </table>		DO NOT OPEN THE PANEL WHILE UNIT IS RUNNING		WARNING		
	DO NOT OPEN THE PANEL WHILE UNIT IS RUNNING					
	WARNING					
Circuit drain - Outside, on the right-hand front column						
<table border="1"> <tr> <td style="text-align: center;"> </td> <td> ATTENTION! Don't leave the unit with water inside hydraulic circuit during winter or when it is in stand by. ATTENZIONE! Non lasciare l'unità con acqua nel circuito idraulico durante l'inverno o quando non è funzionante. ATTENTION! Ne laissez pas l'unité avec de l'eau dans le circuit hydraulique pendant l'hiver ou quand elle ne travaille pas. WARNUNG! Lassen Sie nicht das Wasser in die Schaltung während des Winters oder wenn es nicht funktioniert. ¡ATENCIÓN! No deje el agua en el circuito hidráulico durante el invierno o cuando no está trabajando. </td> </tr> </table>		ATTENTION! Don't leave the unit with water inside hydraulic circuit during winter or when it is in stand by. ATTENZIONE! Non lasciare l'unità con acqua nel circuito idraulico durante l'inverno o quando non è funzionante. ATTENTION! Ne laissez pas l'unité avec de l'eau dans le circuit hydraulique pendant l'hiver ou quand elle ne travaille pas. WARNUNG! Lassen Sie nicht das Wasser in die Schaltung während des Winters oder wenn es nicht funktioniert. ¡ATENCIÓN! No deje el agua en el circuito hidráulico durante el invierno o cuando no está trabajando.				
	ATTENTION! Don't leave the unit with water inside hydraulic circuit during winter or when it is in stand by. ATTENZIONE! Non lasciare l'unità con acqua nel circuito idraulico durante l'inverno o quando non è funzionante. ATTENTION! Ne laissez pas l'unité avec de l'eau dans le circuit hydraulique pendant l'hiver ou quand elle ne travaille pas. WARNUNG! Lassen Sie nicht das Wasser in die Schaltung während des Winters oder wenn es nicht funktioniert. ¡ATENCIÓN! No deje el agua en el circuito hidráulico durante el invierno o cuando no está trabajando.					

Identification of the unit - Outside, on the right-hand front column																																																						
<table border="1"> <tr> <td>CODICE PRODOTTO NEUTRO PRODUCT CODE</td> <td><input type="text"/></td> </tr> <tr> <td></td> <td></td> </tr> <tr> <td>MODELLO MODEL</td> <td><input type="text"/></td> </tr> <tr> <td></td> <td></td> </tr> <tr> <td>MO.NO SERIAL NO.</td> <td><input type="text"/></td> </tr> <tr> <td>MATRICOLA SERIAL NO.</td> <td><input type="text"/></td> </tr> <tr> <td>ANNO DI COSTRUZIONE Manuf. Year</td> <td><input type="text"/></td> </tr> <tr> <td>REFR. <input type="text"/> GWP <input type="text"/> CIRCUIT CHARGE (Kg) (tCO₂eq)</td> <td> <table border="1"> <tr> <td>1</td> <td>2</td> <td>3</td> <td>4</td> </tr> <tr> <td><input type="text"/></td> <td><input type="text"/></td> <td><input type="text"/></td> <td><input type="text"/></td> </tr> </table> </td> </tr> <tr> <td>PS (LATO ALTA / LATO BASSA) PS (HIGH / LOW SIDE)</td> <td>bar <input type="text"/></td> </tr> <tr> <td>TS (ALTA / BASSA) TS (HIGH / LOW)</td> <td>°C <input type="text"/></td> </tr> <tr> <td>ALIM. POTENZA MAIN SUPPLY</td> <td>V / PH / Hz <input type="text"/></td> </tr> <tr> <td>CORRENTE DI SPUNTO LRA</td> <td>(max) A <input type="text"/></td> </tr> <tr> <td>CORRENTE A PIENO CARICO FLA</td> <td>(max) A <input type="text"/></td> </tr> <tr> <td>POTENZA ASSORBITA POWER INPUT</td> <td>(max) Kw <input type="text"/></td> </tr> <tr> <td>PRESS. MAX ESERCIZIO ACQUA MAX WATER OPERATING PRESSURE</td> <td>bar <input type="text"/></td> </tr> <tr> <td>MASSA MASS</td> <td>Kg <input type="text"/></td> </tr> <tr> <td colspan="2"> SYSTEMAIR S.r.l. Via XXV Aprile 29 20825 BARLASSINA MB ITALIA MADE IN ITALY COD.NO: P35952 </td> </tr> <tr> <td>MODELLO: MODEL</td> <td>ANNO DI COSTRUZIONE Manuf. Year</td> </tr> <tr> <td>MATRICOLA: SERIAL NO.</td> <td>ANNO DI COSTRUZIONE Manuf. Year</td> </tr> <tr> <td>CODICE: PRODUCT CODE</td> <td>ANNO DI COSTRUZIONE Manuf. Year</td> </tr> <tr> <td>MODELLO: MODEL</td> <td>ANNO DI COSTRUZIONE Manuf. Year</td> </tr> <tr> <td>MATRICOLA: SERIAL NO.</td> <td>ANNO DI COSTRUZIONE Manuf. Year</td> </tr> <tr> <td>CODICE: PRODUCT CODE</td> <td>ANNO DI COSTRUZIONE Manuf. Year</td> </tr> </table>	CODICE PRODOTTO NEUTRO PRODUCT CODE	<input type="text"/>			MODELLO MODEL	<input type="text"/>			MO.NO SERIAL NO.	<input type="text"/>	MATRICOLA SERIAL NO.	<input type="text"/>	ANNO DI COSTRUZIONE Manuf. Year	<input type="text"/>	REFR. <input type="text"/> GWP <input type="text"/> CIRCUIT CHARGE (Kg) (tCO ₂ eq)	<table border="1"> <tr> <td>1</td> <td>2</td> <td>3</td> <td>4</td> </tr> <tr> <td><input type="text"/></td> <td><input type="text"/></td> <td><input type="text"/></td> <td><input type="text"/></td> </tr> </table>	1	2	3	4	<input type="text"/>	<input type="text"/>	<input type="text"/>	<input type="text"/>	PS (LATO ALTA / LATO BASSA) PS (HIGH / LOW SIDE)	bar <input type="text"/>	TS (ALTA / BASSA) TS (HIGH / LOW)	°C <input type="text"/>	ALIM. POTENZA MAIN SUPPLY	V / PH / Hz <input type="text"/>	CORRENTE DI SPUNTO LRA	(max) A <input type="text"/>	CORRENTE A PIENO CARICO FLA	(max) A <input type="text"/>	POTENZA ASSORBITA POWER INPUT	(max) Kw <input type="text"/>	PRESS. MAX ESERCIZIO ACQUA MAX WATER OPERATING PRESSURE	bar <input type="text"/>	MASSA MASS	Kg <input type="text"/>	SYSTEMAIR S.r.l. Via XXV Aprile 29 20825 BARLASSINA MB ITALIA MADE IN ITALY COD.NO: P35952		MODELLO: MODEL	ANNO DI COSTRUZIONE Manuf. Year	MATRICOLA: SERIAL NO.	ANNO DI COSTRUZIONE Manuf. Year	CODICE: PRODUCT CODE	ANNO DI COSTRUZIONE Manuf. Year	MODELLO: MODEL	ANNO DI COSTRUZIONE Manuf. Year	MATRICOLA: SERIAL NO.	ANNO DI COSTRUZIONE Manuf. Year	CODICE: PRODUCT CODE	ANNO DI COSTRUZIONE Manuf. Year
CODICE PRODOTTO NEUTRO PRODUCT CODE	<input type="text"/>																																																					
MODELLO MODEL	<input type="text"/>																																																					
MO.NO SERIAL NO.	<input type="text"/>																																																					
MATRICOLA SERIAL NO.	<input type="text"/>																																																					
ANNO DI COSTRUZIONE Manuf. Year	<input type="text"/>																																																					
REFR. <input type="text"/> GWP <input type="text"/> CIRCUIT CHARGE (Kg) (tCO ₂ eq)	<table border="1"> <tr> <td>1</td> <td>2</td> <td>3</td> <td>4</td> </tr> <tr> <td><input type="text"/></td> <td><input type="text"/></td> <td><input type="text"/></td> <td><input type="text"/></td> </tr> </table>	1	2	3	4	<input type="text"/>	<input type="text"/>	<input type="text"/>	<input type="text"/>																																													
1	2	3	4																																																			
<input type="text"/>	<input type="text"/>	<input type="text"/>	<input type="text"/>																																																			
PS (LATO ALTA / LATO BASSA) PS (HIGH / LOW SIDE)	bar <input type="text"/>																																																					
TS (ALTA / BASSA) TS (HIGH / LOW)	°C <input type="text"/>																																																					
ALIM. POTENZA MAIN SUPPLY	V / PH / Hz <input type="text"/>																																																					
CORRENTE DI SPUNTO LRA	(max) A <input type="text"/>																																																					
CORRENTE A PIENO CARICO FLA	(max) A <input type="text"/>																																																					
POTENZA ASSORBITA POWER INPUT	(max) Kw <input type="text"/>																																																					
PRESS. MAX ESERCIZIO ACQUA MAX WATER OPERATING PRESSURE	bar <input type="text"/>																																																					
MASSA MASS	Kg <input type="text"/>																																																					
SYSTEMAIR S.r.l. Via XXV Aprile 29 20825 BARLASSINA MB ITALIA MADE IN ITALY COD.NO: P35952																																																						
MODELLO: MODEL	ANNO DI COSTRUZIONE Manuf. Year																																																					
MATRICOLA: SERIAL NO.	ANNO DI COSTRUZIONE Manuf. Year																																																					
CODICE: PRODUCT CODE	ANNO DI COSTRUZIONE Manuf. Year																																																					
MODELLO: MODEL	ANNO DI COSTRUZIONE Manuf. Year																																																					
MATRICOLA: SERIAL NO.	ANNO DI COSTRUZIONE Manuf. Year																																																					
CODICE: PRODUCT CODE	ANNO DI COSTRUZIONE Manuf. Year																																																					
Gravity centre - Base																																																						
<table border="1"> <tr> <td style="writing-mode: vertical-rl; transform: rotate(180deg);"> TENERE SU QUESTA LINEA GANCIO DI SOLLEVAMENTO </td> <td style="text-align: center;"> </td> <td style="writing-mode: vertical-rl; transform: rotate(180deg);"> KEEP LIFT HOOK ON THIS LINE </td> </tr> </table>	TENERE SU QUESTA LINEA GANCIO DI SOLLEVAMENTO		KEEP LIFT HOOK ON THIS LINE																																																			
TENERE SU QUESTA LINEA GANCIO DI SOLLEVAMENTO		KEEP LIFT HOOK ON THIS LINE																																																				
Grounding connection on the electrical board, adjacent to the connection																																																						

2 - Safety (continued)

Start-up warning - Outside the door of the electrical board

ATTENZIONE

INSERIRE LE RESISTENZE DI RISCALDAMENTO OLIO ALMENO 12 ORE PRIMA DI OGNI AVVIAMENTO (SE PREVISTE) PRIMA DELLA MESSA IN TENSIONE ASSICURARSI CHE LE VITI DEI CIRCUITI ELETTRICI SIANO SERRATE COMPLETAMENTE

WARNING

ENERGIZE THE CRANCKCASE HEATER FOR AT LEAST 12 HOURS BEFORE EACH STARTING (IF FITTED) BEFORE TIGHTENING-UP, TO TIGHTEN ALL TERMINAL SCREWS ESPECIALLY THOSE IN MAIN CIRCUIT

WARNUNG

OLSUMPFFHEIZUNG (FALLS VORHANDEN) 12 STUNDEN VOR DEM START EINSCHALTEN VOR INBETRIEBNAHME ALLE SCHRAUBENVERBINDUNGEN NACHZIEHEN, BESONDERS DIE ELEKTRISCHEN ANSCHLUSSE

ATTENTION

ALIMENTER ELECTRIQUEMENT LA RESISTANCE DE CARTER AU MOINS 12 HEURES AVANT CHAQUE DEMARRAGE (SI MONTE SUR LE PRODUIT) AVANT DE DEMARRER LA MACHINE, VERIFIER LE SERRAGE DE TOUTES LES BORNES A VIS, SPECIALEMENT DANS LE BOITIER ELECTRIQUE

ATENCIÓN

ATENCIÓN ALIMENTAR ELÉCTRICAMENTE LA RESISTENCIA DE CARTER AL MENOS 12 HORAS ANTES DE CADA PUESTA EN MARCHA (SI ESTA EQUIPADA EN LA UNIDAD) ANTES DE LA PUESTA EN MARCHA, COMPROBAR QUE LOS BORNES ESTAN BIEN APRETADOS, ESPECIALMENTE EN EL CUADRO ELÉCTRICO

035B00057-000

MADE IN ITALY

Instruction for the lifting

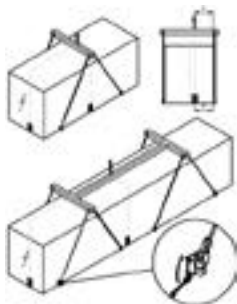

Fitting identification - Adjacent to fittings

EIN - INLET
ENTRÉE - ENTRATA
AUS - OUTLET
SORTIE - USCITA

Final Test Certificate - Inside the external door

QUALITY CHECK PROOF

MODEL/TYPE MODELLO/TIPO	SERIAL NUMBER-PRODUCTION LOT N° DI SERIE-LOTTO DI PRODUZIONE	P. NUMBER CODE CODICE	MANUFACTURED YEAR ANNO DI COSTRUZIONE
NUMBER CHECK NUMERO CONTROLLI	DESCRIPTION OF INSPECTION DESCRIZIONE DEI TEST DI CONTROLLO	INSPECTOR REFERENCE TIMBRO OPERATORE	
01	PRELIMINARY PROOF PRESSURE TEST AND LEAK TEST WITH ELIUM AND NITROGEN AT MINIMUM 10 BAR (REFRIGERANT SIDE) IN COMPLIANCE WITH TEST SPECIFICATION - MARK WITH PENS PROVA PRELIMINARE DI PRESSIONE E TENUTA CIRCUITO CON ELIO E AZOTO AD ALMENO 10 BAR (LATO REFRIGERANTE), IN ACCORDO ALLA SPECIFICA DI COLLAUDO - SEGNARE CON PENNARELLO CARRY OUT AN ADDITIONAL LEAK TEST WITH ELIUM AND NITROGEN AT 2.5 BAR (WATER SIDE) - MARK WITH PENS EFFETTUARE UNA PROVA PRELIMINARE DI TENUTA CON ELIO E AZOTO A 2.5 BAR (LATO ACQUA) - SEGNARE CON PENNARELLO		
02	VACUUM TEST CARRIED OUT VUOTO ESEGUITO		
03	REFRIGERANT CHARGE CARICA REFRIGERANTE		
04	CHECK WIRING CABLE CONNECTION VERIFICA CABLAGGIO ELETTRICO		
05	SAFETY TEST: CONTINUITY, INSULATION, DIELECTRICAL STRENGTH PROVE DI SICUREZZA: CONTINUITÀ, ISOLAMENTO, RIGIDITÀ		
06	RUNNING TEST WITH SAFETY DEVICES COLLAUDO FUNZIONALE COMPLETO CON INTERVENTO SICUREZZA E RILEV		
07	LEAK TEST ON REFRIGERANT CIRCUIT DURING RUNNING CONDITION - MARK WITH PEN VERIFICA TENUTA CIRCUITO REFRIGERANTE DURANTE IL FUNZIONAMENTO - SEGNARE CON PENNARELLO		
08	FINAL LEAK TEST ON REFRIGERANT CIRCUIT AFTER RUNNING - MARK WITH PENS VERIFICA FINALE TENUTA CIRCUITO REFRIGERANTE DOPO IL COLLAUDO FUNZIONALE - SEGNARE CON PENNARELLO		
09	CHECK ASSEMBLY PARTS VERIFICA ASSEMBLAGGIO PARTI		
10	CHECK MOUNTED ACCESSORIES OR SUPPLY LOOSE CONTROLLO ACCESSORI MONTATI E/O FORNITI A BORDO UNITÀ		
11	CHECK DOCS SUPPLY (CE, IOM, START UP FORM, WIRING DIAGRAM, RULES) VERIFICA DOCUMENTI FORNITI CON L'UNITÀ		
12	CHECK STICKERS, LABELLING VERIFICA TARGHETTE		
13	AESTHETICAL CHECK AND CLEANING CONTROLLO ESTETICO/PULIZIA		
14	CHECK TEST SHEET AND CHECK LIST FILLED UP CONTROLLO COMPILAZIONE SCHEDA DI COLLAUDO E CHECK LIST		

On the coil



ATTENZIONE! BORDI TAGLIANTI
VORSICHT! SCHARFE RÄNDER
CAUTION! SHARP EDGES
ATTENTION! BORDS COUPANTS
ATENCIÓN! PERFIL AFILADO

Warning - Safety valve vents

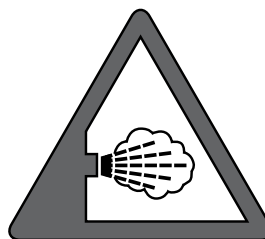

Warning - High temperature zone adjacent to hot pipes or components



2 - Safety (continued)

2.8 Safety regulations

REFRIGERANT DATA	SAFETY DATA: R134a
Toxicity	Low
Contact with skin	<p>If sprayed, the refrigerant is likely to cause frost burns. If absorbed by the skin, the danger is very limited; it may cause a slight irritation, and the liquid is degreasing. Unfreeze the affected skin with water.</p> <p>Remove the contaminated clothes with great care - in the presence of frost burns, the clothes may stick to the skin. Wash with plenty of warm water the affected skin.</p> <p>In the presence of symptoms such as irritation or blisters, obtain medical attention.</p>
Contact with eyes	<p>Vapours do not cause harmful effects. The spraying of refrigerant may cause frost burns.</p> <p>Wash immediately with a proper solution or with tap water for at least 10 minutes, and then obtain medical attention.</p>
Ingestion	<p>Very unlikely - should something happen, it will cause frost burns.</p> <p>Do not induce vomiting. Only if the patient is conscious, wash out mouth with water and give some 250 ml of water to drink. Then, obtain medical attention.</p>
Inhalation	<p>R134a: remarkable concentrations in the air may have an anaesthetic effect, up to fainting.</p> <p>The exposure to considerable amounts may cause irregular heartbeat, up to the sudden death of the patient. Very high concentrations may result in the risk of asphyxia, due to the reduction in the oxygen percentage in the atmosphere. Remove the patient to fresh air and keep warm and at rest.</p> <p>If necessary, give oxygen. In case of breathing difficulties or arrest, proceed with artificial respiration.</p> <p>In case of cardiac arrest, proceed with cardiac massage. Then, obtain medical attention.</p>
Recommendations	<p>Semiotics or support therapy is recommended. Cardiac sensitisation has been observed that, in the presence of circulating catecholamines such as adrenalin, may cause cardiac arrhythmia and accordingly, in case of exposure to high concentrations, cardiac arrest.</p>
Prolonged exposure	<p>R134a: a study on the effects of exposure to 50,000 ppm during the whole life of rats has identified the development of benign testicle tumour.</p> <p>This situation should therefore be negligible for personnel exposed to concentrations equal to or lower than professional levels.</p>
Professional levels	R134a: Recommended threshold: 1000 ppm v/v - 8 hours TWA.
Stability	R134a: Not specified
Conditions to avoid	Do not use in the presence of flames, burning surfaces and excess humidity.
Hazardous reactions	<p>May react with sodium, potassium, barium and other alkaline metals.</p> <p>Incompatible substances: magnesium and alloys with magnesium concentrations > 2%.</p>
Hazardous decomposition products	R134a: Halogen acids produced by thermal decomposition and hydrolysis.

2 - Safety (continued)

2.8 Safety regulations (continued)

REFRIGERANT DATA	SAFETY DATA: R134a
General precautions	Do not inhale concentrated vapours. Their concentration in the atmosphere should not exceed the minimum preset values and should be maintained below the professional threshold. Being more weighty than the air, the vapour concentrates on the bottom, in narrow areas. Therefore, the exhaust system must work at low level.
Respiratory system protection	If you are in doubt about the concentration in the atmosphere, it is recommended to wear a respirator approved by an accident-prevention Authority, of the independent or oxygen type.
Storage	Cylinders must be stored in a dry and fresh place, free from any fire hazard, far from direct sunlight or other sources of heat, radiators etc. Keep a temperature below 45 °C.
Protective clothing	Wear overalls, protective gloves and goggles or a mask.
Accidental release measures	It is important to wear protective clothing and a respirator. Stop the source of the leak, if you can do this without danger. Negligible leaks can be left evaporating under the sun, providing that the room is well ventilated. Considerable leaks: ventilate the room. Reduce the leak with sand, earth or other absorbing substances. Make sure that the liquid does not channelled into gutters, sewers or pits where the vapours are likely to create a stuffy atmosphere.
Disposal	The best method is recovery and recycling. If this method is not practicable, dispose according to an approved procedure, that shall ensure the absorption and neutralization of acids and toxic agents.
Fire fighting information	R134a: Not flammable in the atmosphere.
Cylinders	The cylinders, if exposed to fire, shall be cooled by water jets; otherwise, if heated, they may explode.
Protective fire fighting equipment	In case of fire, wear an independent respirator and protective clothing.

2 - Safety (continued)

2.8 Safety regulations (continued)

LUBRICANT OIL DATA	SAFETY DATA: POLYESTER OIL (POE)
Classification	Not harmful.
Contact with skin	May cause slight irritation. Does not require first aid measures. It is recommended to follow usual personal hygiene measures, including washing the exposed skin with soap and water several times a day. It is also recommended to wash your overalls at least once a week.
Contact with eyes	Wash thoroughly with a suitable solution or tap water.
Ingestion	Seek medical advice immediately.
Inhalation	Seek medical advice immediately.
Conditions to avoid	Strong oxidising substances, caustic or acid solutions, excess heat. May corrode some types of paint or rubber.
Protection of the respiratory system	Use in well ventilated rooms.
Protective clothing	Always wear protective goggles or a mask. Wearing protective gloves is not mandatory, but is recommended in case of prolonged exposure to refrigerant oil.
Accidental release measures	It is important to wear protective clothing and, especially, goggles. Stop the source of the leak. Reduce the leak with absorbing substances (sand, sawdust or any other absorbing material available on the market).
Disposal	The refrigerant oil and its waste will be disposed of in an approved incinerator, in conformity with the provisions and the local regulations applicable to oil waste.
Fire fighting information	In the presence of hot liquid or flames, use dry powder, carbon dioxide or foam. If the leak is not burning, use a water jet to remove any vapours and to protect the personnel responsible for stopping the leak.
Cylinders	The cylinders exposed to a fire will be cooled with water jets in case of fire.
Fire fighting protective equipment	In case of fire, wear an independent respirator.

3 - Transport, Lifting and Positioning

Refrigerators are supplied assembled (apart from standard antivibrating rubber supports, that will be installed on site). The equipment are full of refrigerant and oil, in the quantity required for a proper operation.

3.1 Inspection

When the unit is delivered, it is recommended to check it carefully and to identify any damage occurred during transportation. The goods are shipped ex-factory, at the buyer's risk. Check that the delivery includes all the components listed in the order.

In case of damage, note it down on the carrier's delivery note and issue a claim according to the instructions provided in the delivery note.

In the presence of any serious damage, that does not affect the surface only, it is recommended to inform manufacturer immediately.

Please note that manufacturer may not be held liable for any damage to the equipment during transportation, even though the carrier has been appointed by the factory.

3.2 Lifting

The unit must be lifted by using the hooks inserted into the relevant eyebolts (see the figure).

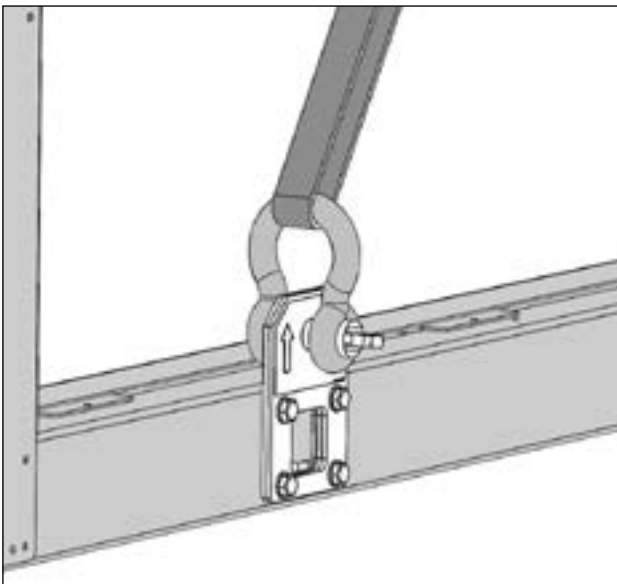

It is recommended to use a spacer to prevent cables from damaging the unit (see the figure).

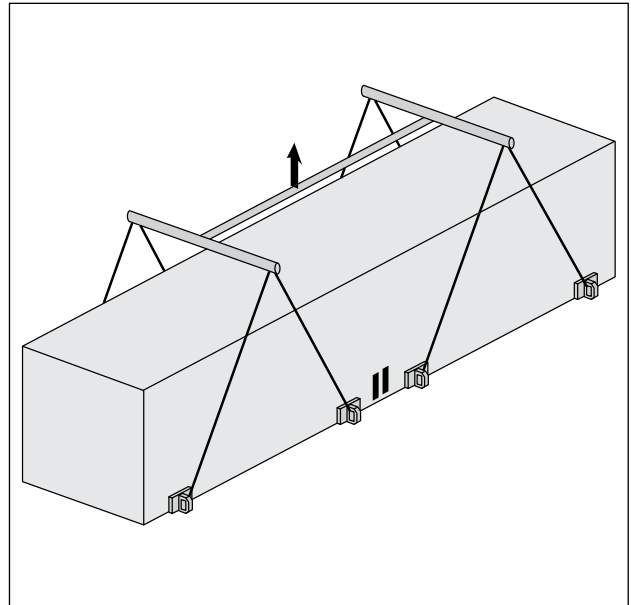

Before positioning the unit, make sure that the place of installation is appropriate and sturdy enough to hold the weight and to withstand the stress caused by the operation of the whole assembly.



Do not displace the unit on rollers, and do not lift it with a lift truck.

Unit must be lifted carefully.

To lift unit slowly and regularly.

To lift and displace the unit:

- Insert and secure eyebolts into the holes marked on the frame.
- Insert spacer between cables.
- Hook near the barycentre of the unit.
- The cables must be long enough to form, if tensioned, an angle of at least 45° with respect to the horizontal plane.



For lifting operations, use only tools and material fit for this purpose, in accordance with accident-prevention regulations.

3 - Transport, Lifting and Positioning (continued)



During the lifting and handling of the unit, be careful not to damage the finned pack of the coils positioned on the sides of the unit.

The sides of the unit must be protected by cardboard or plywood sheets.



It is recommended not to remove the protective plastic envelope, that should prevent scraps from penetrating into the appliance and any damage to the surfaces, until the unit is ready for operation.



The lifting eyebolts protrude from the base of the unit; it is therefore recommended to remove them once the unit has been lifted and positioned, if in your opinion they are likely to become a source of hazard and injury.

The eyebolts must be mounted on the unit whenever it shall be displaced and then lifted again.

3.3 Anchoring

It is not essential to secure the unit to the foundations, unless in areas where there is a serious risk of earthquake, or if the appliance is installed on the top of a steel frame.

3.4 Storage

When the unit is to be stored before installation, adopt a few precautions to prevent any damage or risk of corrosion or wear:

- plug or seal every single opening, such as water fittings
- do not store the appliance in a room where the temperature exceeds 50 °C for the units using R134a and, if possible, do not expose to direct sunlight
- minimum storage temperature is -25 °C
- it is recommended to store the unit in a roof where traffic is minimized, to prevent the risk of accidental damage
- the unit must not be washed with a steam jet
- take away and leave to the site manager all the keys providing access to the control board

Finally, it is recommended to carry out visual inspections at regular intervals.

4 - Installation

4.1 Positioning of the unit



Before installing the unit, make sure that the structure of the building and/or the supporting surface can withstand the weight of the appliance. The weights of the units are listed in Chapter 8 of this manual.

These units have been designed for outdoor installation on a solid surface. Standard accessories include antivibrating rubber supports, that must be positioned under the base.

When the unit is to be installed on the ground, it is necessary to provide a concrete base, to ensure a uniform distribution of the weights.

As a general rule, no special sub-bases are required. However, if the unit is to be installed on the top of inhabited rooms, it is advisable to rest it on spring shock absorbers (optional), that will minimise the transmission of any vibration to the structures.

To choose the place of installation of the unit, bear in mind that:

- the longitudinal axis of the unit must be parallel to the direction of prevailing winds, so as to ensure a uniform distribution of the air on finned exchangers
- the unit must not be installed near boilers' vent pipes
- the unit must not be installed leeward with respect to sources of air contaminated by greases, such as, for example, the outlets to kitchen exhaust hoods into the atmosphere. Otherwise, the grease is likely to deposit on the fins of the refrigerant /air exchangers, and would fix every type of atmospheric impurity, resulting in the quick clogging of the exchangers
- the unit must not be installed in areas subject to considerable snow falling
- the unit must not be installed in areas subject to flooding, under gutters etc.
- the unit must not be installed in air shafts, narrow courts or other small places, where the noise may be reflected by the walls or the air ejected by fans may short-circuit itself on refrigerant/air heat exchangers or condenser
- the place of installation must be have all the necessary spaces for air circulation and maintenance operations (see Chapter 8).

4.2 Spring Isolator Installation

- Prepare the base, that must be flat and plane.
- Lift the appliance and insert shock absorbers as follows:

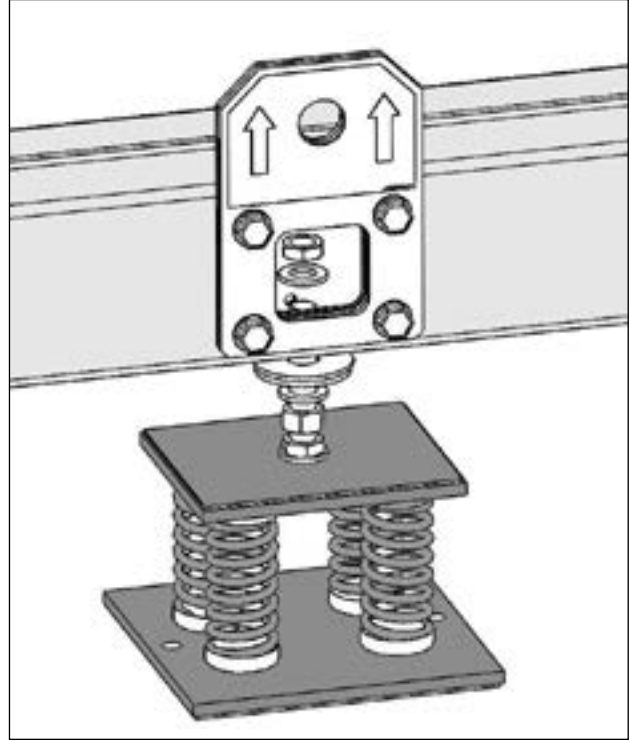

4 - Installation (continued)

4.3 External Water Circuit

The flow switch and the filter water, although not included in the supply, must always be fitted such as plant components. Their installation is mandatory for warranty.



The external hydraulic circuit must ensure the water flow to the evaporator under any working or adjustment conditions.

The circuit shall be composed by the following elements:

- A circulation pump which can ensure the necessary capacity and discharge head.
- The capacity of the primary hydraulic circuit should not be less than 7.5 litres/KW of cooling capacity, in order to prevent the repeated start-up of the compressor and any damage to it. If the water capacity in the primary piping of the circuit and in the evaporator is lower than this value, an insulated storage tank shall be installed.
- A membrane expansion vessel provided with safety valve with vent, that must be visible.



The capacity of the expansion vessel must allow for an expansion of at least 2% of the volume of the fluid in the circuit (evaporator, piping, user circuit and standby tank, if any). The expansion vessel needs not be isolated, because no water can circulate inside it.

A flow switch will stop the unit when the water is not circulating or a flow rate problem occurs.

To install the flow switch, follow the manufacturer's instructions.

As a general rule, the flow switch shall be mounted on a horizontal pipe, at a distance from the curves equal to 10 times the diameter of the pipe and far from valves or other components that are likely to hinder the water flow upstream of or downstream from the flow switch.

- The bleed valves must be mounted on the highest point of the piping.
- The stop valves must be mounted on the piping of the water entering/leaving the evaporator.
- The drain points (provided with plugs, cocks etc.) must be arranged in the lowest point of the piping.



The flow switch must be connected (terminals 1-2) as shown in the wiring diagram of the "User's Terminal Box".

RECOMMENDED WATER COMPOSITION		
PH	7,5 - 9	
Electrical conductivity	10 - 500	μS/cm
Total hardness	4,5 - 8,5	dH
Temperature	< 60	[°C]
Alkalinity (HCO ₃ ⁻)	70-300	ppm
Alkalinity / Sulphates (HCO ₃ ⁻ / SO ₄ ²⁻)	> 1	ppm
Sulphates (SO ₄ ²⁻)	< 70	ppm
Chlorides (Cl)	< 50	ppm
Free Chlorine	< 0,5	ppm
Phosphates (PO ₄ ³⁻)	< 2	ppm
Ammonia (NH ₃)	< 0,5	ppm
Ammonium Ion (NH ₄ ⁺)	< 2	ppm
Manganese Ion (Mn ²⁺)	< 0,05	ppm
Free Carbon Dioxide (CO ₂)	< 5	ppm
Hydrogen Sulfide (H ₂ S)	< 0,05	ppm
Oxygen Content	< 0,1	ppm
Nitrates (NO ₃ ⁻)	< 100	ppm
Manganese (Mn)	< 0,1	ppm
Iron (Fe)	< 0,2	ppm
Aluminium (Al)	< 0,2	ppm

Caution

If the water circuit is to be drained for a time exceeding one month, the circuit must be fully charged with nitrogen to prevent any risk of corrosion by differential venting

4 - Installation (continued)

Then:

- Provide the evaporator with a by-pass circuit equipped with a valve to wash the plant.
- Insulate the piping, to prevent the risk of heat loss.
- Position a filter on the suction side of the evaporator of the heat recovery condenser.

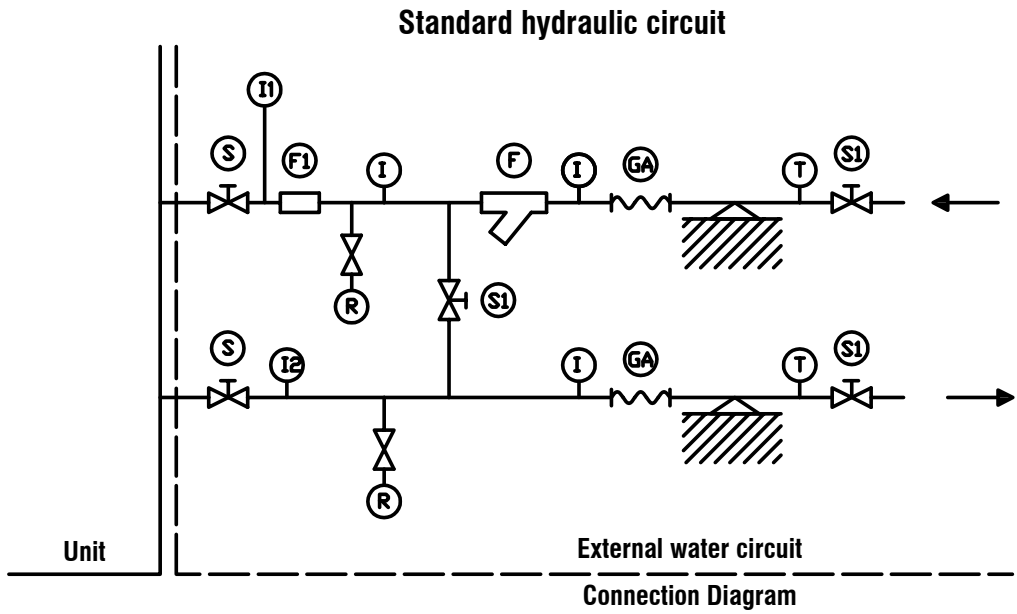

COMPONENTS			
I	Pressure gauge connection	R	Drain cock
S	Gate valve	T	Thermometer
F1	Flow Switch	F	Filter
GA	Flexible hoses	I1/I2	Pressure gauge connection to measure pressure drop or head pressure

Before filling the circuit, it is important to check that it is free from any foreign matter, sand, gravels, rust, welding deposits, waste and other materials that may damage the evaporator.

When cleaning the lines, it is recommended to create a circuit by-pass. It is important to mount a filtering medium (30 mesh) upstream of the chiller.

If necessary, the water required to fill the circuit must be treated to obtain the requested pH.

4.4 Hydraulic connection

The water inlet/outlet fittings shall conform to the instructions provided by the plates affixed near the connection points.

4 - Installation (continued)

4.5 Connection of water temperature sensors (on shell and tube evaporator)

The units are provided with fittings for hydraulic connections between heat exchangers and plant.

Each fitting is complete with sensor well to fasten temperature sensor (BT-IN and BT-OUT). Fittings are supplied separate and must be mounted during the installation of the unit.

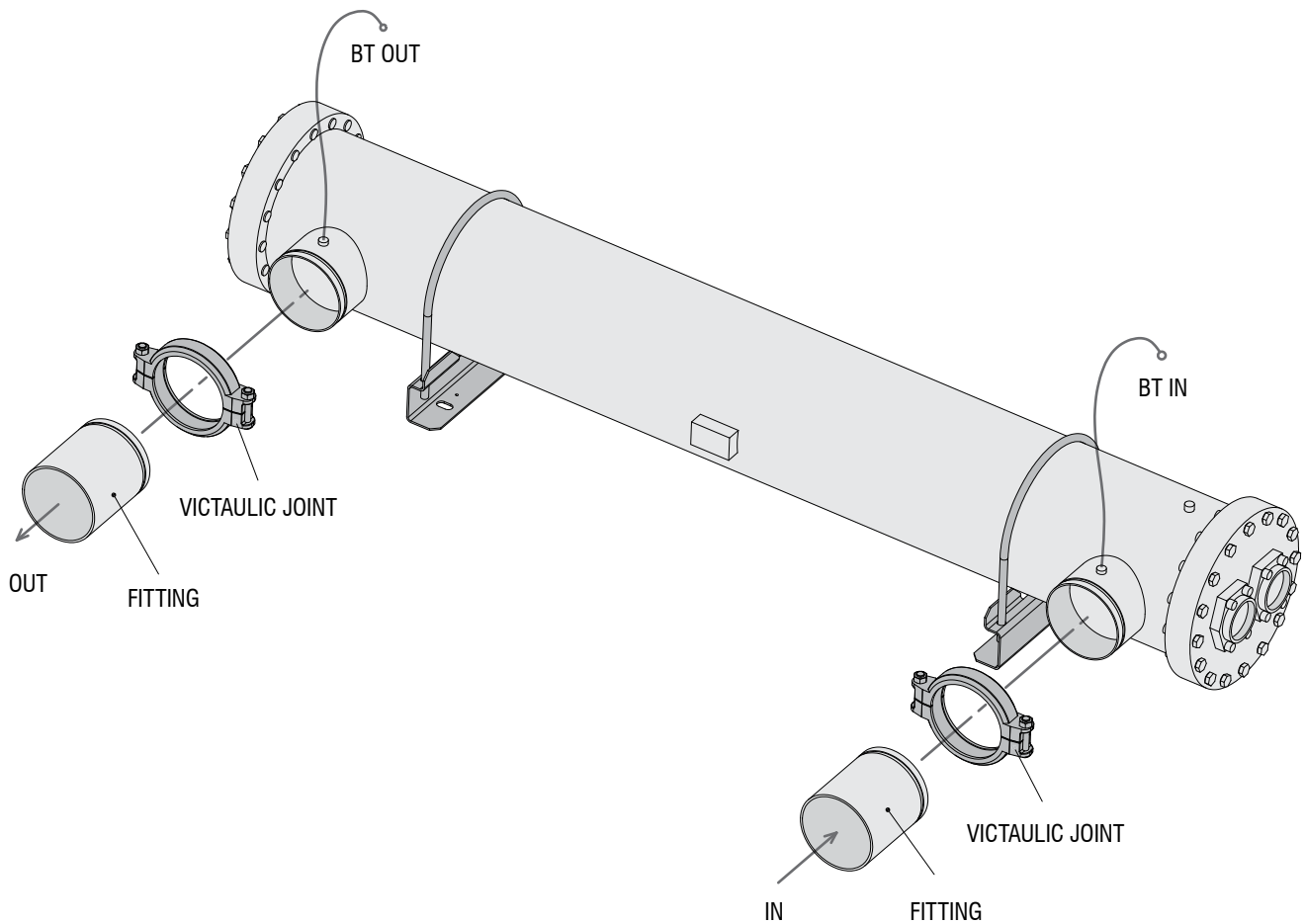

4 - Installation (continued)

4.6 Power supply

	<p>Before carrying out any operations on the electrical system, make sure that the unit is deenergised.</p>
---	---

	<p>It is important that the appliance is grounded.</p>
---	---

	<p>The company in charge of the installation shall conform to the standards applicable to outdoor electrical connections.</p>
---	---

The manufacturer may not be held liable for any damage and/or injury caused by failure to comply with these precautions.

The unit conforms to EN 60204-1.

The following connections shall be provided:

- A 3-phase and grounding connection for the power supply circuit.
- The electrical distribution system shall meet the power absorbed by the appliance.
- The disconnecting and magnetothermal switches must be sized to control the starting current of the unit.
- The power supply lines and the insulation devices must be designed in such a way that every line independent.
- It is recommended to install differential switches, to prevent any damage caused by phase drops.
- The fans and compressors are supplied through contactors controlled from the control panel.
- Each motor is provided with an internal safety thermal device and external fuses.
- The power supply cables must be inserted into dedicated openings on the front of the unit, and they will enter the electrical board through holes drilled on the bottom of the board.

4.7 Electrical connections

The unit must be installed on site according to the Machinery Directive 2006/42/EC, Electromagnetic Compatibility Directive 2014/30/EU and the usual procedures and standards applicable in the place of installation.

The unit must not be operated if its installation has not been carried out according to the instructions provided in this manual.

The power supply lines must consist of insulated copper conductors, dimensioned for the maximum absorbed current.

Connection to terminals must be performed according to the diagram of connections (User's Terminal Box) provided in this manual and according to the wiring diagram which accompanies the unit.

	<p>Before connecting the power supply lines, check that the available voltage value does not exceed the range specified in the Electric Data (Chapter 8).</p>
---	---

For 3-phase systems, check also that the unbalance between the phases does not exceed 2%. To perform this check, measure the differences between the voltage of each phase couple and their mean value during operation.

The maximum % value of these differences (unbalance) must not exceed 2% of the mean voltage.

If the unbalance is unacceptable, contact the Energy Distributor to solve this problem.

	<p>Supplying the unit through a line whose unbalance exceeds the permissible value will automatically void the warranty.</p>
---	--

4 - Installation (continued)

Electrical connections - Units with standard step and stepless type compressors

QG - Y1

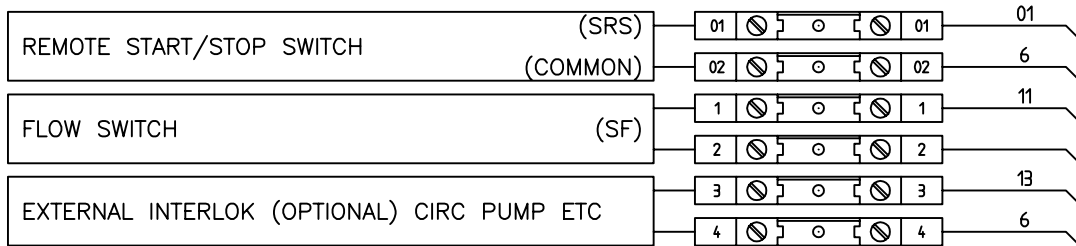

QG - Y2

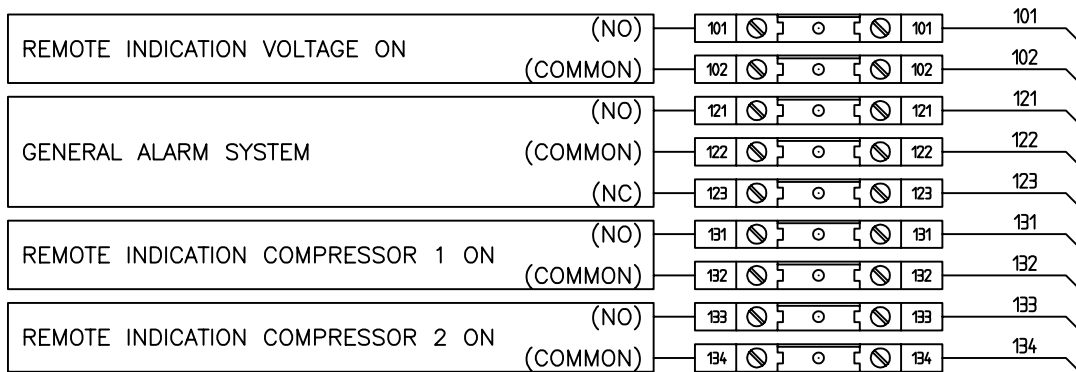

QG - Y3

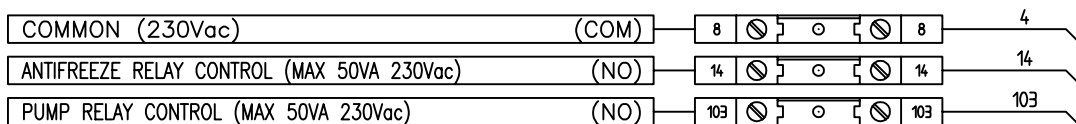

5 - Start-Up



The unit must be started for the first time by personnel suitably trained by one Authorised Service Centre. Failure to meet this requirement will immediately void the warranty.



The operations carried out by authorised personnel are limited to the start-up of the unit, and do not include any other operation on the plant, such as, for example, electrical and hydraulic connections etc.

All the other operations before start-up, including oil pre-heating for at least 12 hours, must be performed by the Installer.

5.1 Preliminary check

The checks listed below shall be performed before starting the unit and before the arrival of the personnel authorised.

- Check the section of power supply and grounding cables; make sure that terminals are tightened and check the correct operation of contactors, with the main switch open.
- Check that any voltage and phase variation in the power supply does not exceed the prefixed thresholds.
- Connect the contacts of the flow switch and the thermal relay of the pump and of the other devices (if any), to terminals 1-2 and 3-4, respectively.
- Check that the components of the external water circuit (pump, user equipment, filters, power supply tank and reservoir, if any) have been installed properly, and according to the manufacturer's instructions.
- Check the filling of the hydraulic circuits, and make sure that the fluid circulation is correct, without any trace of leaks and air bubbles. If you use ethylene glycol as antifreeze, check that its percentage is correct.
- Check that the direction of rotation of the pumps is correct, and that fluids have been circulating for at least 12 hours for both pumps. Then, clean the filters on the suction side of the pumps.
- Adjust the liquid distribution network in such a way that the flow rate is within the specified range.
- Check that the water quality is up to the specifications.
- Check that oil heaters, if any, have been turned on at least 12 hours before.

5.2 Start-up

Start-up sequence:

- Turn on the Main switch (at least 12 hours before).
- Check that the oil in the compressor has reached the requested temperature (the minimum temperature outside the pan must be approx. 40°C) and that the auxiliary control circuit is energised.
- Check the operation of all the external equipment, and make sure that the control devices of the plant are properly calibrated.

- Start the pump and check that the water flow is correct.
- Set the desired fluid temperature on the control board.
- Start the appliance (see Chapter 6).
- Check the correct direction of rotation of compressors. Scroll compressors cannot compress the refrigerant when they rotate in the opposite direction. To make sure that they are rotating in the correct direction, simply check that, just after the start-up of the compressor, the pressure drops on the LP side and rises on the HP side. Furthermore, if a scroll compressor rotate in the opposite direction, there is a considerable rise in the sound level of the unit, as well as in a dramatic reduction of current absorption compared to normal values. In case of wrong rotation, the scroll compressor can be definitely damaged. Phase monitor is assembled in the unit as a standard to prevent wrong compressors rotation.
- After about 15 minutes of operation check that there are no bubbles, through the sight glass on the liquid line.



The presence of bubbles may indicate that a part of the refrigerant charge has been released in one or more points. It is important to remove these leaks before proceeding.

- Repeat the start-up procedure after removing the leaks.
- Check the oil level in the compressor's sight glass.

5.3 Checking the operation

Check the following:

- The temperature of the water entering the evaporator.
- The temperature of the water leaving the evaporator.
- The level of the water flow rate in the evaporator, if possible.
- The current absorption upon the start of the compressor and in case of stabilised operation.
- The fan's current absorption.

Check that the condensing and evaporation temperatures, during operation at high and low pressure detected by the pressure gauges of the refrigerant, are within the following range:

(On the units not provided with HP/LP pressure gauges for the refrigerant, connect a pressure gauge to the Schrader valves on the refrigeration circuit).

HP side	Approx. 15 to 21 °C above the temperature of the air entering the condenser, for R134a units.
LP side	Approx. 2 to 7 °C below the temperature of the leaving chilled water, for R134a units.

5.4 Delivery to the customer

- Train the user according to the instructions provided in Section 6.

6 - Control

6 General information

Introduction

This document contains the information and the operating instructions for screw compressors of step type.

This information is for the after-sales service and the production operators, for the end-of-line testing.

Main characteristics

- Microprocessor control
- User-friendly keyboard
- Proportional and integral control of the return water temperature (RWT)
- Hysteresis control of the leaving water temperature (LWT)
- Access code to enter the Manufacturer's Level
- Access code to enter the Assistance Level
- Alarm and LED
- Backlighting LCD
- Pump-Down logic
- Rotation of the compressor operation
- Oil return function
- Night mode (or Low Noise) control
- Counting of the pump/compressors' hours of operation
- Display of discharge and suction pressure values
- Display of temperature sensor
- History of stored alarms (option)
- Built-in serial Communication RS485 Card; to connect the "Chiller Control" to a BMS network

The following accessories can be also connected:

- Remote Display Terminal
- Wire Remote Control.

The control system consists of:

- a) Main Board. The units are provided with a microprocessor card which is fully programmed by default for the control of a chiller of cold only type with 2 circuits, 1 compressor for circuit, a HP transducer and a LP transducer for Circuit.
- b) EEV controllers (two separate drivers) to the management of the electronic expansion valves.
- c) Keyboard & Display Terminal.









The terminal makes it possible to carry out the following operations:

- the initial configuration of the machine
- the change of all the main operating parameters
- the display of the detected alarms
- the display of all the measured quantities

The terminal and the card are connected by a 6-way phone cable.

The connection of the terminal to the basic card is not essential for the normal operation of the controller.

6 - Control (continued)

	<p>Esc key: allows you to move from one mask to another.</p>
	<p>Alarm key: used to display the alarms, to reset them in manual. Press it one to display the mask of the activated alarm, press it again to reset the alarm signal.</p>
	<p>Prg+Esc keys: Pressing these keys at the same time, allows you to turn the unit on/off.</p>
	<p>Up-down keys: allows you to set the control parameters' values and to move from one mask to another (not backlighted).</p>
	<p>Enter key: used to move the cursor inside the masks and to save the values of the set parameters.</p>
	<p>Alarm + Enter keys: press these keys at the same time to enter the "historical alarm" after 1' come back at status machine menu.</p>

6.1 Display/Keyboard



The display is an LCD 8 lines x 22 columns. The quantities and the information about the operation of the unit are alternated in the form of subsequent screens, named "masks".

It is possible to move inside the masks with the terminal keys as described below.

Arrows key - Up/Down/Enter

If the cursor is in the top left-hand corner (Home), press the UP/DOWN keys to access the subsequent masks associated to the selected branch. If a mask includes some value setting fields and you press the ENTER key, the cursor will reach these fields.

Once you have reached the quantity setting field, you can modify any value (within the expected limits) by pressing the UP/DOWN keys.

After you have selected the desired value, press the ENTER key again to store it.

6 - Control (continued)

Alarms

Alarm code	Description	Notes
1	Main board - EPROM Failure	
2	Main board - Clock card Failure	
3	Main board - External air temperature sensor fault	
4	Main board - Return Water temperature sensor fault	
5	Main board - Leaving Water temperature sys 1 sensor fault	
6	Main board - Leaving Water temperature sys 2 sensor fault	
7	Main board - Low pressure sys 1 sensor fault	
8	Main board - Low pressure sys 2 sensor fault	
9	Main board - High pressure sys 1 sensor fault	
10	Main board - High pressure sys 2 sensor fault	
11	Main board - Discharge temperature sys 1 sensor fault	
12	Main board - Discharge temperature sys 2 sensor fault	
13	Main board - Coil Temperature sys 1 sensor fault	
14	Main board - Coil Temperature sys 2 sensor fault	
15	Flow switch / Interlock / Serious alarm (SQZ)	
16	Serious alarm (SQZ)	
17	Flow switch / Interlock	
18	Oil Safety Sys 1 manual reset	
19	Oil Safety Sys 2 manual reset	
20	High pressure switch Sys 1	
21	High pressure switch Sys 2	
22	Low pressure Sys 1 switch manual reset	
23	Low pressure Sys 2 switch manual reset	
24	Thermal protection compressor 1 Sys 1 manual reset	
27	Thermal protection compressor 1 Sys 2 manual reset	
30	Fan Thermal protection manual reset	
31	Fan Thermal protection Group 1 Sys 1 manual reset	
32	Fan Thermal protection Group 2 Sys 1 manual reset	
33	Fan Thermal protection Group 1 Sys 2 manual reset	
34	Fan Thermal protection Group 2 Sys 2 manual reset	
35	Low refrigerant cutout Sys 1 manual reset	
36	Low refrigerant cutout Sys 2 manual reset	
37	Low pressure alarm Sys 1 manual reset	
38	Low pressure alarm Sys 2 manual reset	
39	Out of envelope Sys 1 manual reset	
40	Out of envelope Sys 2 manual reset	
41	High pressure Sys 1 manual reset	
42	High pressure Sys 2 manual reset	
43	High limit discharge temperature Sys1 manual reset	
44	High limit discharge temperature Sys2 manual reset	
45	ΔT Water Too High	
47	Wrong Water Trend	
49	Antifreeze alarm manual reset	
51	Antifreeze alarm Recovery manual reset	
52	Pump maintenance	
53	Compressor 1 Sys 1 maintenance	
56	Compressor 1 Sys 2 maintenance	
59	Driver 1 LAN disconnected	
60	Driver 2 LAN disconnected	
61	EPROM Error Driver 1	
62	EPROM Error Driver 2	
63	Driver 1 S1 Sensor fault	
64	Driver 1 S3 Sensor fault	
65	Driver 1 S2 Sensor fault	
66	Driver 1 S4 Sensor fault	
67	Driver 2 S1 Sensor fault	
68	Driver 2 S3 Sensor fault	
69	EEV motor Error (Check wiring) Sys 1	
70	EEV motor Error (Check wiring) Sys 2	
71	Driver 1 Battery alarm	

6 - Control (continued)

Alarm code	Description	Notes
72	Driver 2 Battery alarm	
73	Autotune alarm Sys 1	
74	Autotune alarm Sys 2	
75	Low suction alarm Sys 1	
76	Low suction alarm Sys 2	
77	Driver 1 Regulation Alarm	
78	Driver 2 Regulation Alarm	
79	Expansion board 1 OFF LINE	
80	Expansion board 2 OFF LINE	
81	Expansion board 1 - Sensor 1 fault	
82	Expansion board 1 - Sensor 2 fault	
83	Expansion board 1 - Sensor 3 fault	
84	Expansion board 1 - Sensor 4 fault	
85	Safety Extra Heater	
86	Recovery Flow switch	
87	Low delta pressure Sys 1 manual reset	
88	Low delta pressure Sys 2 manual reset	
118	Oil Safety Sys 1 auto reset	
119	Oil Safety Sys 2 manual reset	
122	Low pressure Sys 1 switch auto reset	
123	Low pressure Sys 2 switch auto reset	
124	Thermal protection compressor 1 Sys 1 auto reset	
127	Thermal protection compressor 1 Sys 2 auto reset	
130	Fan Thermal protection auto reset	
131	Fan Thermal protection Group 1 Sys 1 auto reset	
132	Fan Thermal protection Group 2 Sys 1 auto reset	
133	Fan Thermal protection Group 1 Sys 2 auto reset	
134	Fan Thermal protection Group 2 Sys 2 auto reset	
135	Low refrigerant cutout Sys 1 auto reset	
136	Low refrigerant cutout Sys 2 auto reset	
137	Low pressure alarm Sys 1 auto reset	
138	Low pressure alarm Sys 2 auto reset	
139	Out of envelope Sys 1 auto reset	
140	Out of envelope Sys 2 auto reset	
141	High pressure Sys 1 auto reset	
142	High pressure Sys 2 auto reset	
143	High limit discharge temperature Sys1 auto reset	
144	High limit discharge temperature Sys2 auto reset	
187	Low delta pressure Sys 1 auto reset	
188	Low delta pressure Sys 2 auto reset	

6.2 Setpoint

Pressing the Set key allows you to enter the Set point level accessible to the user. The parameters that can be set are listed below, along with the limit values and the default values (standard shop settings):

User parameters	Control mode	Min value	Max value	Default
Cooling Setpoint	RWT Return Control	9	15	10
	LWT Leaving Control	6	15	8
Cooling Setpoint - glycol water	RWT Return Control	-5	15	10
	LWT Leaving Control	-8	15	8
Proportional band	RWT Return Control	1	10	5
Neutral band	LWT Leaving Control	1	6	2
Languages	—	ITA ENG FRE GER SPA		ITA
System On/Off				
System 1 #	—	OFF	ON	OFF
System 2 #	—	OFF	ON	OFF
Unit management		Cooling		

6 - Control (continued)

6.3 Protection and Safety Equipment

Refrigeration system

The units are filled with R134a refrigerant fluid of non hazardous type (group II). Safety device (pressure switch and safety valves) with the sets below indicated are provided on the discharge and suction line of each circuit.

Discharge Line

Pressure relief valve 21 bar.
Pressure switch 19 bar.

Suction line

Pressure relief valve 14.5 bar.
Pressure switch 0.5 bar.

Frost Protection for the Chilled Fluid

These units are provided with frost protection for the chilled fluid. This protection consists of an electrical resistor positioned in contact with the coolant/circulating fluid exchanger, which is activated (although the unit is off) when the temperature of the fluid drops below 5 °C - the standard value for a non-glycol unit.

If the leaving water temperature drops below 4 °C (standard value for a non-glycol unit) the machine's antifreeze alarm is activated. If the circulating fluid is water, before the beginning of the cold season it is advisable to drain the circuit to prevent water frosting.

If the circuit cannot be drained, it is essential to avoid de-energizing the unit, so as to permit the activation, when necessary, of the frost protection.

Compressor protection

Compressors are equipped with a heating element to prevent oil dilution, which may result in remarkable risks of failure of compressors.

The windings of the compressors' motors are provided with a thermal protection.

An accessory kit for thermal protection (ACB) is available, for any overcurrent of compressors, which shall be shop-mounted.

Electrical flow switch

A electrical flow switch must be installed, to prevent the unit working in case of insufficient circulation of the chilled fluid.



The electrical flow switch must be carefully installed, according to the instructions given by the Manufacturer.

The electrical flow switch must be installed on the pressing side of the circulation pump for the fluid, just upstream of the heat exchanger's inlet. The electrical flow switch must be installed in a horizontal straight length of piping, in a position reasonably far (both upstream and downstream) from localized pressure drops (curves, valves etc.).

Continuous Regulation of the Fan Speed

The fans' speed regulator, if installed, allows the unit to work at an ambient temperature down to -10 °C.

6 - Control (continued)

6.4 HPF version configuration

Units equipped with High pressure fan (HPF) can be set-up on the field to give the unit a specific static pressure.

By entering parameter in service level - Max Speed (Vdc) - it is possible to modify high static pressure. The table below shows the correspondance between chiller model, fan RPM, high static pressure (approximate values).

Model	Fan Static Pressure (Pa)	Fan RPM	Parameter in Service Level: Max Speed (Vdc)
300-1400	0	900	8,1
	30	950	8,5
	70	1.000	9,0
	100	1.050	9,4
	120	1.100	10,0

7 - Product Description

7.1 Introduction

The units are air cooled water chillers provided with screw compressors with two refrigeration circuits.

These units can be installed outdoor on the roof of a building or at ground level.

These units are fit for cooling intermediate fluids (glycoled water), for air-conditioning applications in industrial processes.

This series includes the following versions:

VERSION (1)	DESCRIPTION
Base Low Noise version (-)	Air cooled water chillers, using R134a refrigerant.
Low Noise version (L)	
Extra Low Noise version (S)	
High pressure fan (HPF) (1)	
High Temperature version (HT) (1)	

(1) A high pressure fan (HPF) version and High Temperature (HT) version are equipped with brushless fans.

Special Version

Polar Version: Unit with Electronic fans and dedicate devices on refrigeration system allows the units to operate at ambient temperature down to -18°C.

Brine Version: Unit with dedicate devices on refrigeration system allows the units to operate with brine (ethylenic or propylenic glycol) down to -8 °C.

Available options:

OPTIONS	DESCRIPTION
Desuperheater (D)	The heat recovery is carried out by a desuperheater mounted on the compressor's discharge line.
Totally heat recovery	Not available. For information, please contact commercial office.

7.2 General specifications

The units are supplied complete and provided with all connecting pipes for the refrigerant and internal wiring.

The refrigeration circuit of each unit undergoes a pressure test, is drained, vacuumised, dehydrated and filled with refrigerant, and includes the necessary oil. Once assembled, each unit is subjected to a complete final testing and the correct operation of all refrigeration circuits is checked.

The base and the frame of each unit are made of very thick galvanised sheet, and are secured by screw and stainless bolts. All panels are secured by screw and tropicalised steel bolts, they can be disassembled for easy access to internal components.

All galvanised steel parts are painted with white polyester resin, to ensure the resistance of the unit to corrosion and weather agents over time.

7.3 Compressors

The units are provided with high power, high efficiency and low vibration level semi-hermetic screw compressors (oil injection or external cooling with plate-type exchangers) to reduce the compressor's discharge temperature (on request for special application).

The capacity control can be both of the step type (as standard) or of the stepless type (on request). It is handled by capacity control solenoid valves, handled by the microprocessor of the appliance.

The motor's terminals are weatherproof, according to standard IP-54.

7.4 Refrigeration circuits

The units are provided with two independent circuits with screw compressors for each circuit and "S&T" shell and tube heat exchanger.

Each refrigerant circuit includes: a service valve for refrigerant filling, shutoff valves for suction lines (on request), as well as for the delivery and liquid lines, an electronic expansion valve, that completely closed (as a solenoid valve) makes it possible to start/stop the compressor, a dehydrating cartridge filter, a sight glass with humidity indicator.

Furthermore, each circuit is equipped with safety devices in accordance with PED 2014/68/EU: high and low pressure switches, safety valves providing protection in case of fire or malfunction of compressors.

7 - Product Description (continued)

7.5 Water heat exchanger

Evaporator

The units are provided with a direct-expansion refrigerant/water shell and tube heat exchanger with several refrigeration circuits.

The evaporators are insulated with UV ray-proof 19 mm-thick anti-condensate closed-cell polyethylene material.

The external surface is provided with wire electric heaters (400-800 W), which prevent frosting at low temperatures (down to -18 °C) when the unit is off.

Desuperheater

All units are available with desuperheaters (DSH). DSH is refrigerant/water heat exchanger with brazed plates.

DSH is fitted on the compressor discharge pipe and it's dimensioned to recover about the 20% of total rejected heat. Each unit is equipped with 2 exchangers, one for each circuit.

Total heat recovery condenser

All units are available with total heat recovery condenser (THRC). THRC is refrigerant / water heat exchanger with brazed plates or shell and tube, according to chiller size. THRC is fitted on the compressor discharge pipe in parallel with the standard cooling circuit. The heat recovery function is by means of a four-way valve. Each unit is equipped with 2 exchangers, one for each circuit. Exchangers are insulated with UV ray-proof 19 mm-thick anticondensate closed-cell polyethylene material.

7.6 Air heat exchanger

Coils are microchannel type, made of 100% aluminum (fins, tubes and headers).

7.7 Fans

The condenser's fans are of large diameter (800 mm) axial type. They are provided with external diffusers (nozzles), that reduce the aerodynamic motor to a large extent. Each fan is provided with galvanised steel accident-prevention guard, painted after assembly.

Finally, the fans' motors are completely closed, protection class IP54, protection thermostat immersed in windings.

7.8 Electric power supply and control system

All units are provided with a microprocessor and a "Chiller Control" system.

The electrical connection of the controls and the startup units for the motor are carried out and tested in the factory. The power supply and control components are separate and accessible from different doors.

A door stop disconnecting switch is always available, and is mounted on the door of the appliance, supply side. The cabinet includes also another door, that can be opened from the top, waterproofed according to IP 54 standard.

The power supply compartment includes:

- Master switch
- Network isolator, contactors, compressor fuses

Control panel includes:

- A transformer for auxiliaries, fuses, relay and electronic card, a thermostat for the compressor's delivery temperature
- The keyboard and the display of the "Chiller-Control" microcomputer, mounted on the door of the control section.

7.9 Accessories

List of available accessories, provided separately, to be mounted on site by the installer:

Water flow switch

Prevents the operation of the unit when the chilled fluid is insufficient. It is advisable to install a flow switch, to ensure the correct operation of the unit.

Water filter

Filter to be mounted on the suction side of the water heat exchanger. It is mandatory to install a water filter to remove impurities from the water supply.

Antivibrating supports (AVM)

Isolating spring supports, equipped with bolts for fastening to the base. They are supplied separated from the unit and must be mounted on site by the customer, at his own expense.

Remote wall terminal

Makes it possible to check the unit through a remote terminal, up to a maximum distance of 400 meters.

Modem GSM

Makes it possible to check the working mode or the switching on/off of the unit via SMS. In case of any alarms, the unit sends an SMS to the user.

RS-485 serial card (for MODBUS or LONWORK or BACNET)

A communication interface makes it possible to control and manage the unit from a local station, with RS485 connection, up to a distance of 1000 m.

It is possible to obtain the remote control and the management, by inserting the control into the management plant of the building.

Internal hydro kits

Consist of pump(s) and relevant accessories (tank is not available inside the unit).

External hydro kits

Consist of buffer tank, pump(s), relevant accessories and with or without tank antifreeze heater.

7 - Product Description (continued)

Refrigerant flow diagram - Unit 300-360

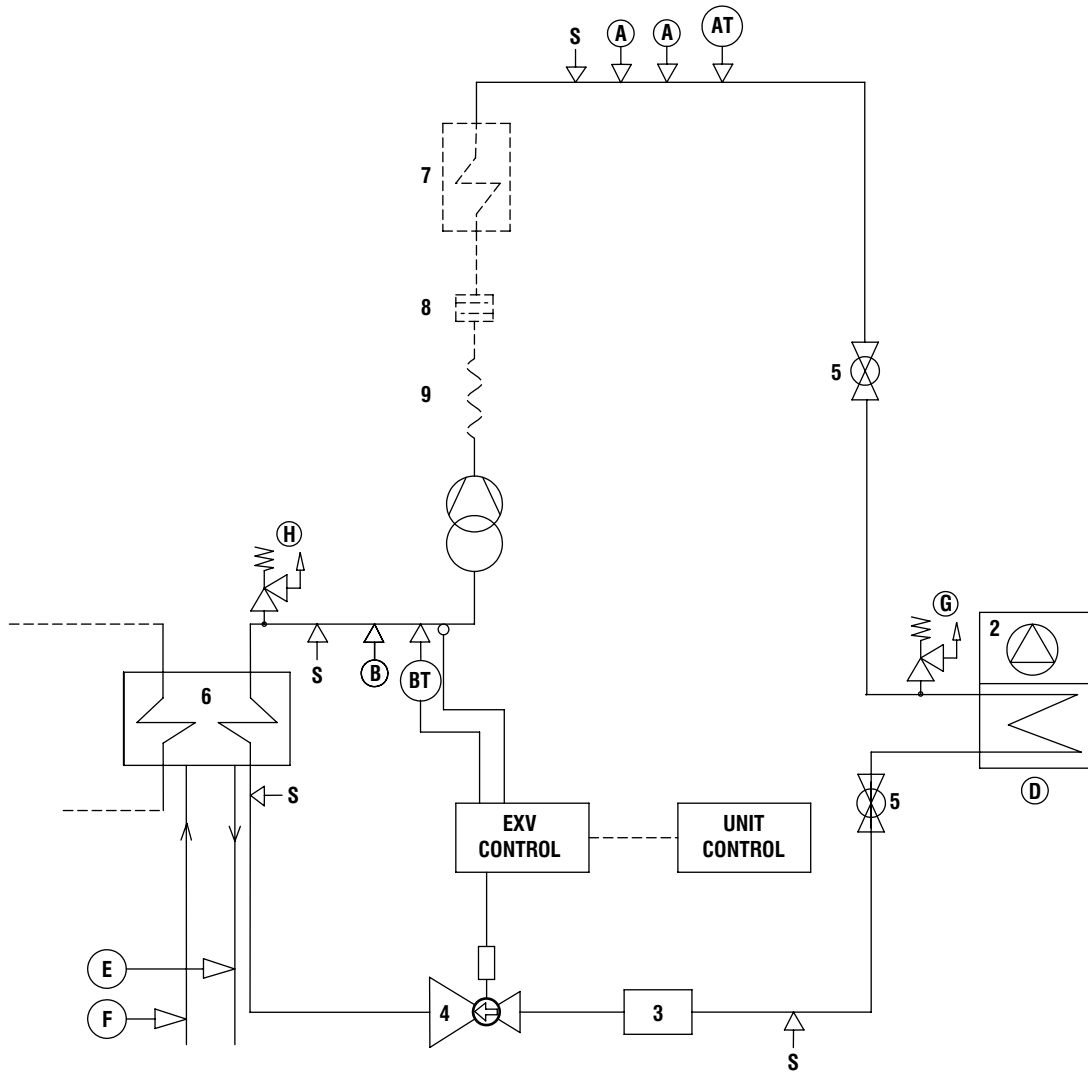

COMPONENTS	
1	Compressor (Screw type)
2	Air cooled condenser
3	Filter drier
4	Electronic expansion valve
5	Globe valve
6	Heat exchanger (Shell & Tube Type)
7	Desuperheater (Optional)
8	Muffler (Optional)
9	Anti-vibration pipe (Optional)

SAFETY / CONTROL DEVICES	
A	High pressure switch (19 bar)
B	Low pressure switch (0.5 bar)
AT	High pressure transducer
BT	Low pressure transducer
D	Air temperature sensor
E	Outlet water temperature sensor
F	Inlet water temperature sensor
G	PED pressure relief valve HP side (21 bar)
H	PED pressure relief valve LP side (14.5 bar)
S	Schrader connection (Service only)
↓	Pipe connection with Schrader valve

Note: For reasons of readability, one circuit only is shown. The second circuit is identical.

7 - Product Description (continued)

Refrigerant flow diagram - Unit 410-450-650-720-1000-1070-1130-1170-1300-1400

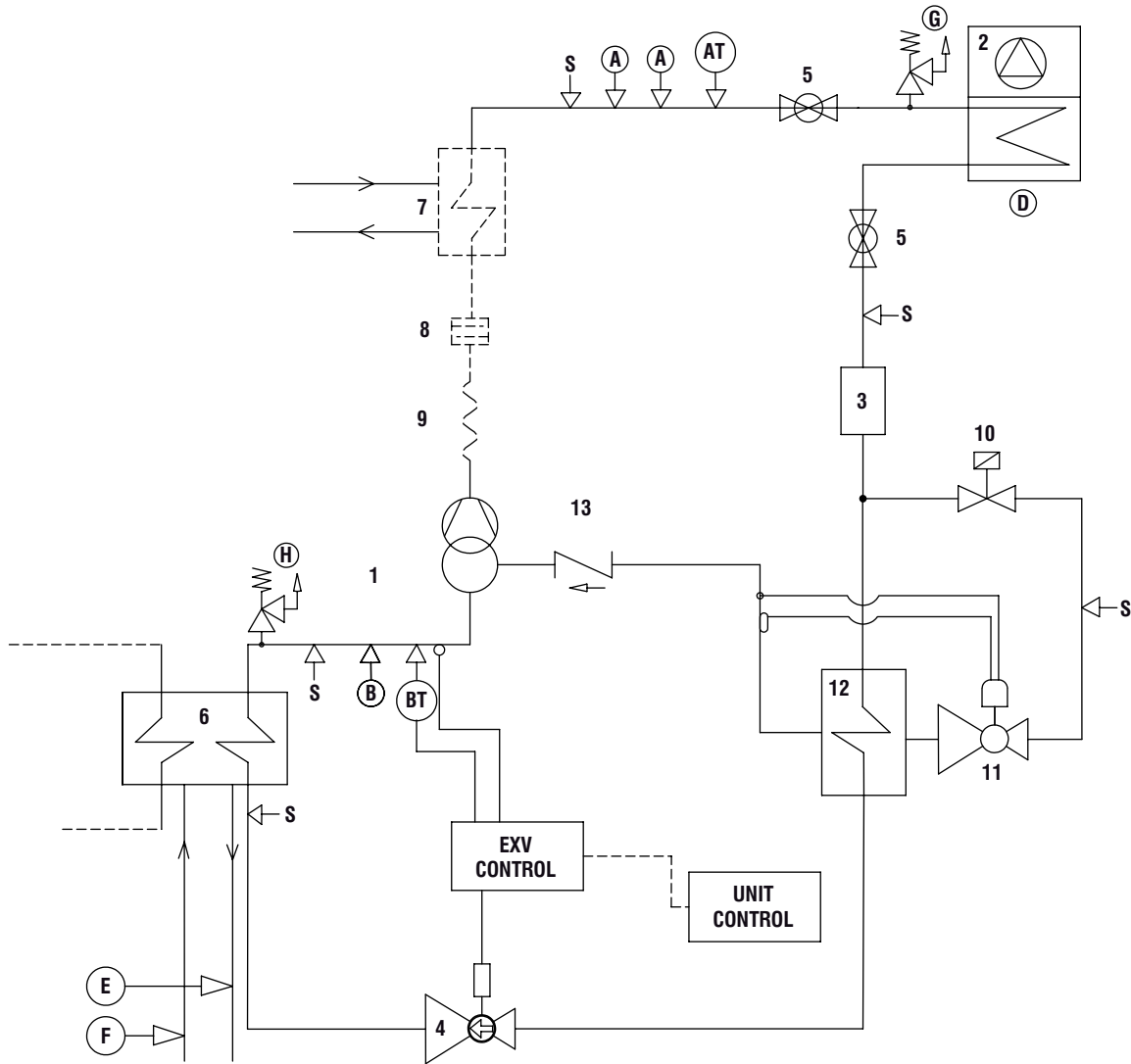

COMPONENTS	
1	Compressor (Screw type)
2	Air cooled condenser
3	Filter drier
4	Electronic expansion valve
5	Globe valve
6	Heat exchanger (Shell & Tube Type)
7	Desuperheater (Optional)
8	Muffler (Optional)
9	Anti-vibration pipe (Optional)
10	Solenoid valve (ECO)
11	Thermostatic expansion valve (ECO)
12	Heat exchanger (Phetype) (ECO)
13	Non return valve (ECO)

SAFETY / CONTROL DEVICES	
A	High pressure switch (19 bar)
B	Low pressure switch (0.5 bar)
AT	High pressure transducer
BT	Low pressure transducer
D	Air temperature sensor
E	Outlet water temperature sensor
F	Inlet water temperature sensor
G	PED pressure relief valve HP side (21 bar)
H	PED pressure relief valve LP side (14.5 bar)
S	Shrader connection (Service only)
↓	Pipe connection with Shrader valve

8 - Technical Data

8.1 Pressure drops

Evaporator Pressure drop

Model	Nom. Capacity	Qnom.	Qmax.	Qmin.	K	Dp nom	DP max	DP min
	kW	l/h	l/h	l/h	kPa/(l/h) ^ 2	kPa	kPa	kPa
300	296	50.878	84.796	31.799	1.405E-08	36.4	101.0	14.2
360	366	63.004	105.006	39.377	1.444E-08	57.3	159.3	22.4
410	415	71.328	118.881	44.580	7.663E-09	39.0	108.3	15.2
450	447	76.815	128.025	48.010	7.663E-09	45.2	125.6	17.7
480	482	82.870	138.116	51.794	7.663E-09	52.6	146.2	20.6
500	506	87.032	145.053	54.395	4.191E-09	31.7	88.2	12.4
540	541	93.086	155.144	58.179	4.191E-09	36.3	100.9	14.2
580	576	99.141	165.235	61.963	4.112E-09	40.4	112.3	15.8
650	653	112.385	187.308	70.241	2.400E-09	30.3	84.2	11.8
720	715	122.980	204.967	76.863	2.400E-09	36.3	100.8	14.2
800	796	136.981	228.301	85.613	2.475E-09	46.4	129.0	18.1
850	855	147.008	245.014	91.880	2.475E-09	53.5	148.6	20.9
910	913	157.036	261.727	98.148	2.439E-09	60.2	167.1	23.5
970	975	167.631	279.385	104.770	1.979E-09	55.6	154.5	21.7
1000	1.012	174.064	290.107	108.790	1.979E-09	60.0	166.6	23.4
1070	1.074	184.659	307.765	115.412	8.999E-10	30.7	85.2	12.0
1130	1.135	195.254	325.424	122.034	8.999E-10	34.3	95.3	13.4
1170	1.175	202.066	336.776	126.291	8.594E-10	35.1	97.5	13.7
1200	1.221	210.012	350.020	131.258	8.594E-10	37.9	105.3	14.8
1300	1.320	227.040	378.400	141.900	8.521E-10	43.9	122.0	17.2
1400	1.399	240.662	401.104	150.414	8.459E-10	49.0	136.1	19.1

Desuperheater pressure drop

Model	Nom. Capacity	Qnom.	Qmax.	Qmin.	K	Dp nom	DP max	DP min
	kW (*)	l/h	l/h	l/h	kPa/(l/h) ^ 2	kPa	kPa	kPa
300	27	4.590	7.650	2.869	1,2201E-07	2,6	7,1	1,0
360	34	5.802	9.670	3.626	1,2201E-07	4,1	11,4	1,6
410	38	6.535	10.892	4.084	1,2201E-07	5,2	14,5	2,0
450	41	7.110	11.851	4.444	8,2611E-08	4,2	11,6	1,6
480	44	7.625	12.709	4.766	8,2611E-08	4,8	13,3	1,9
500	47	8.015	13.358	5.009	8,2611E-08	5,3	14,7	2,1
540	50	8.581	14.302	5.363	5,3791E-08	4,0	11,0	1,5
580	53	9.138	15.231	5.712	5,3791E-08	4,5	12,5	1,8
650	60	10.295	17.158	6.434	5,3791E-08	5,7	15,8	2,2
720	65	11.219	18.698	7.012	4,1753E-08	5,3	14,6	2,1
800	72	12.439	20.732	7.774	4,1753E-08	6,5	17,9	2,5
850	78	13.357	22.261	8.348	2,8203E-08	5,0	14,0	2,0
910	83	14.302	23.837	8.939	2,8203E-08	5,8	16,0	2,3
970	89	15.252	25.420	9.532	2,8203E-08	6,6	18,2	2,6
1000	92	15.785	26.309	9.866	2,1147E-08	5,3	14,6	2,1
1070	97	16.768	27.946	10.480	2,1147E-08	5,9	16,5	2,3
1130	103	17.709	29.515	11.068	2,1147E-08	6,6	18,4	2,6
1170	107	18.382	30.637	11.489	2,000E-08	6,8	18,8	2,6
1200	111	19.153	31.922	11.971	2,000E-08	7,3	20,4	2,9
1300	120	20.687	34.478	12.929	2,000E-08	8,6	23,8	3,3
1400	127	21.770	36.283	13.606	2,000E-08	9,5	26,3	3,7

(*) Capacity referred to only one circuit.

8 - Technical Data (continued)

8.2 Technical data

Standard		300	360	410	450	480	500	540	580
Power supply	V/Ph/Hz	400V/3/50Hz							
Number of refrigerant circuits		2	2	2	2	2	2	2	2
Start-up Type		PW	PW	PW	PW	PW	PW	PW	SD
Total capacity steps	%	25-50-62-75-87-100							
COMPRESSOR									
Number		2	2	2	2	2	2	2	2
Type		Screw							
INTERNAL HEAT EXCHANGER (EVAPORATOR)									
Number		1	1	1	1	1	1	1	1
Type		Shell & tube (Pure counterflow)							
Water connections	inch	5	5	6	6	6	6	6	6
EXTERNAL HEAT EXCHANGER (COILS)									
Number		6	6	8	8	8	8	9	10
Type		MCHX - Al/Alloy							
FAN									
Number		6	6	8	8	8	8	9	10
Air flow	m ³ /h	38.3	38.3	51.1	51.1	51.1	51.1	57.5	63.9
Total input power	kW	12.6	12.6	16.8	16.8	16.8	16.8	18.9	21.0
REFRIGERANT									
Type / GWP		R134a / 1430							
Charge 1 / 2 (1)	kg	21,5 / 21,5	26 / 26	30 / 30	29 / 36	33 / 37	33 / 33	36 / 42	40 / 40
	tCO ₂ eq	30,7 / 30,7	37,2 / 37,2	42,9 / 42,9	41,5 / 51,5	47,2 / 52,9	47,2 / 47,2	51,5 / 60,1	57,2 / 57,2
DESUPERHEATER									
Number		2	2	2	2	2	2	2	2
Type		PHE							
Water flow Rate	l/s	1.85	2.29	2.58	2.81	3.01	3.17	3.39	3.61
Water Pressure Drop	kPa	4.3	6.6	8.3	7.3	8.4	7.0	8.0	9.1
WEIGHT									
Shipping	kg	3.160	3.200	3.520	3.830	4.140	4.170	4.400	4.660
Operating	kg	3.270	3.300	3.670	3.990	4.290	4.320	4.550	4.800
DIMENSIONS									
Length	mm	4.600	4.600	4.600	4.600	4.600	4.600	5.700	6.700
Width	mm	2.200	2.200	2.200	2.200	2.200	2.200	2.200	2.200
Height	mm	2.510	2.510	2.510	2.510	2.510	2.510	2.510	2.510

(1) The refrigerant value are indicative values for standard units. The actual data are indicated on the unit label.

8 - Technical Data (continued)

Standard		650	720	800	850	910	970	1000
Power supply	V/Ph/Hz	400V/3/50Hz						
Number of refrigerant circuits		2	2	2	2	2	2	2
Start-up Type		SD	SD	SD	SD	SD	SD	SD
Total capacity steps	%	25-50-62-75-87-100						
COMPRESSOR								
Number		2	2	2	2	2	2	2
Type		Screw						
INTERNAL HEAT EXCHANGER (EVAPORATOR)								
Number		1	1	1	1	1	1	1
Type		Shell & tube (Pure counterflow)						
Water connections	inch	6	6	8	8	8	8	8
EXTERNAL HEAT EXCHANGER (COILS)								
Number		12	12	12	14	14	15	16
Type		MCHX - Al/Alloy						
FAN								
Number		12	12	12	14	14	15	16
Air flow	m ³ /h	76.7	76.7	76.7	89.4	89.4	95.8	102.2
Total input power	kW	25.2	25.2	25.2	29.4	29.4	31.5	33.6
REFRIGERANT								
Type / GWP		R134a / 1430						
Charge 1 / 2 (1)	kg	48 / 48	49 / 55	57 / 57	57 / 67	66 / 66	69 / 74	74 / 74
	tCO ₂ ,eq	68,6 / 68,6	70,1 / 78,7	81,5 / 81,5	81,5 / 95,8	94,4 / 94,4	98,7 / 105,8	105,8 / 105,8
DESUPERHEATER								
Number		2	2	2	2	2	2	2
Type		PHE						
Water flow Rate	l/s	4.07	4.43	4.92	5.28	5.65	6.03	6.24
Water Pressure Drop	kPa	6.8	8.1	10.0	7.9	9.0	10.3	7.9
WEIGHT								
Shipping	kg	5.080	5.500	5.990	6.510	6.600	6.810	6.900
Operating	kg	5.330	5.760	6.220	6.750	6.830	7.090	7.180
DIMENSIONS								
Length	mm	6.700	6.700	6.700	8.800	8.800	8.800	8.800
Width	mm	2.200	2.200	2.200	2.200	2.200	2.200	2.200
Height	mm	2.510	2.510	2.510	2.510	2.510	2.510	2.510

(1) The refrigerant value are indicative values for standard units. The actual data are indicated on the unit label.

8 - Technical Data (continued)

Standard		1070	1130	1170	1200	1300	1400
Power supply	V/Ph/Hz	400V/3/50Hz					
Number of refrigerant circuits		2	2	2	2	2	2
Start-up Type		SD	SD	SD	SD	SD	SD
Total capacity steps	%	25-50-62-75-87-100					
COMPRESSOR							
Number		2	2	2	2	2	2
Type		Screw					
INTERNAL HEAT EXCHANGER (EVAPORATOR)							
Number		1	1	1	1	1	1
Type		Shell & tube (Pure counterflow)					
Water connections	inch	6	6	8	8	10	10
EXTERNAL HEAT EXCHANGER (COILS)							
Number		17	18	19	20	22	24
Type		MCHX - Al/Alloy					
FAN							
Number		17	18	19	20	22	24
Air flow	m ³ /h	108.6	115.0	121.4	127.8	140.6	153.4
Total input power	kW	35.7	37.8	39.9	42.0	46.2	50.4
REFRIGERANT							
Type / GWP		R134a / 1430					
Charge 1 / 2 (1)	kg	73 / 83	83 / 83	79 / 92	89 / 89	96 / 104	102 / 102
	tCO ₂ ,eq	104,4 / 118,7	118,7 / 118,7	113,0 / 131,6	127,3 / 127,3	137,3 / 148,7	145,9 / 145,9
DESUPERHEATER							
Number		2	2	2	2	2	2
Type		PHE					
Water flow Rate	l/s	6.63	7.00	7.27	7.57	8.18	8.66
Water Pressure Drop	kPa	8.9	7.7	8.3	7.0	8.2	9.2
WEIGHT							
Shipping	kg	7.490	7.760	7.970	8.180	8.570	8.890
Operating	kg	7.880	8.150	8.350	8.560	8.940	9.245
DIMENSIONS							
Length	mm	9.900	10.900	10.900	10.900	12.000	13.000
Width	mm	2.200	2.200	2.200	2.200	2.200	2.200
Height	mm	2.510	2.510	2.510	2.510	2.510	2.510

(1) The refrigerant value are indicative values for standard units. The actual data are indicated on the unit label.

8 - Technical Data (continued)

L - Low Noise Version		300	360	410	450	480	500	540	580
Power supply	V/Ph/Hz	400V/3/50Hz							
Number of refrigerant circuits		2	2	2	2	2	2	2	2
Start-up Type		PW	PW	PW	PW	PW	PW	PW	SD
Total capacity steps	%	25-50-62-75-87-100							
COMPRESSOR									
Number		2	2	2	2	2	2	2	2
Type		Screw							
INTERNAL HEAT EXCHANGER (EVAPORATOR)									
Number		1	1	1	1	1	1	1	1
Type		Shell & tube (Pure counterflow)							
Water connections	inch	5	5	6	6	6	6	6	6
EXTERNAL HEAT EXCHANGER (COILS)									
Number		6	6	8	8	8	8	9	10
Type		MCHX - Al/Alloy							
FAN									
Number		6	6	8	8	8	8	9	10
Air flow	m ³ /h	31.8	31.8	42.4	42.4	42.4	42.4	47.8	53.1
Total input power	kW	6.9	6.9	9.2	9.2	9.2	9.2	10.4	11.5
REFRIGERANT									
Type / GWP		R134a / 1430							
Charge 1 / 2 (1)	kg	21,5 / 21,5	26 / 26	30 / 30	29 / 36	33 / 37	33 / 33	36 / 42	40 / 40
	tCO ₂ ,eq	30,7 / 30,7	37,2 / 37,2	42,9 / 42,9	41,5 / 51,5	47,2 / 52,9	47,2 / 47,2	51,5 / 60,1	57,2 / 57,2
DESUPERHEATER									
Number		2	2	2	2	2	2	2	2
Type		PHE							
WEIGHT									
Shipping	kg	3.160	3.200	3.520	3.830	4.140	4.170	4.400	4.660
Operating	kg	3.270	3.300	3.670	3.990	4.290	4.320	4.550	4.800
DIMENSIONS									
Length	mm	4.600	4.600	4.600	4.600	4.600	4.600	5.700	6.700
Width	mm	2.200	2.200	2.200	2.200	2.200	2.200	2.200	2.200
Height	mm	2.510	2.510	2.510	2.510	2.510	2.510	2.510	2.510

(1) The refrigerant value are indicative values for standard units. The actual data are indicated on the unit label.

8 - Technical Data (continued)

L - Low Noise Version		650	720	800	850	910	970	1000
Power supply	V/Ph/Hz	400V/3/50Hz						
Number of refrigerant circuits		2	2	2	2	2	2	2
Start-up Type		SD	SD	SD	SD	SD	SD	SD
Total capacity steps	%	25-50-62-75-87-100						
COMPRESSOR								
Number		2	2	2	2	2	2	2
Type		Screw						
INTERNAL HEAT EXCHANGER (EVAPORATOR)								
Number		1	1	1	1	1	1	1
Type		Shell & tube (Pure counterflow)						
Water connections	inch	6	6	8	8	8	8	8
EXTERNAL HEAT EXCHANGER (COILS)								
Number		12	12	12	14	14	15	16
Type		MCHX - Al/Alloy						
FAN								
Number		12	12	12	14	14	15	16
Air flow	m ³ /h	63.7	63.7	63.7	74.3	74.3	79.6	84.9
Total input power	kW	13.8	13.8	13.8	16.1	16.1	17.3	18.4
REFRIGERANT								
Type / GWP		R134a / 1430						
Charge 1 / 2 (1)	kg	48 / 48	49 / 55	57 / 57	57 / 67	66 / 66	69 / 74	74 / 74
	tCO ₂ ,eq	68,6 / 68,6	70,1 / 78,7	81,5 / 81,5	81,5 / 95,8	94,4 / 94,4	98,7 / 105,8	105,8 / 105,8
DESUPERHEATER								
Number		2	2	2	2	2	2	2
Type		PHE						
WEIGHT								
Shipping	kg	5.080	5.500	5.990	6.510	6.600	6.810	6.900
Operating	kg	5.330	5.760	6.220	6.750	6.830	7.090	7.180
DIMENSIONS								
Length	mm	6.700	6.700	6.700	8.800	8.800	8.800	8.800
Width	mm	2.200	2.200	2.200	2.200	2.200	2.200	2.200
Height	mm	2.510	2.510	2.510	2.510	2.510	2.510	2.510

(1) The refrigerant value are indicative values for standard units. The actual data are indicated on the unit label.

8 - Technical Data (continued)

L - Low Noise Version		1070	1130	1170	1200	1300	1400
Power supply	V/Ph/Hz	400V/3/50Hz					
Number of refrigerant circuits		2	2	2	2	2	2
Start-up Type		SD	SD	SD	SD	SD	SD
Total capacity steps	%	25-50-62-75-87-100					
COMPRESSOR							
Number		2	2	2	2	2	2
Type		Screw					
INTERNAL HEAT EXCHANGER (EVAPORATOR)							
Number		1	1	1	1	1	1
Type		Shell & tube (Pure counterflow)					
Water connections	inch	8	8	8	8	10	10
EXTERNAL HEAT EXCHANGER (COILS)							
Number		17	18	19	20	22	24
Type		MCHX - Al/Alloy					
FAN							
Number		17	18	19	20	22	24
Air flow	m ³ /h	90.2	95.5	100.8	106.1	116.7	127.3
Total input power	kW	19.6	20.7	21.9	23.0	25.3	27.6
REFRIGERANT							
Type / GWP		R134a / 1430					
Charge 1 / 2 (1)	kg	73 / 83	83 / 83	79 / 92	89 / 89	96 / 104	102 / 102
	tCO ₂ ,eq	104,4 / 118,7	118,7 / 118,7	113,0 / 131,6	127,3 / 127,3	137,3 / 148,7	145,9 / 145,9
DESUPERHEATER							
Number		2	2	2	2	2	2
Type		PHE					
WEIGHT							
Shipping	kg	7.490	7.760	7.970	8.180	8.570	8.890
Operating	kg	7.880	8.150	8.350	8.560	8.940	9.245
DIMENSIONS							
Length	mm	9.900	10.900	10.900	10.900	12.000	13.000
Width	mm	2.200	2.200	2.200	2.200	2.200	2.200
Height	mm	2.510	2.510	2.510	2.510	2.510	2.510

(1) The refrigerant value are indicative values for standard units. The actual data are indicated on the unit label.

8 - Technical Data (continued)

S - Super Low Noise Version		300	360	410	450	480	500	540	580
Power supply	V/Ph/Hz	400V/3/50Hz							
Number of refrigerant circuits		2	2	2	2	2	2	2	2
Start-up Type		PW	PW	PW	PW	PW	PW	PW	SD
Total capacity steps	%	25-50-62-75-87-100							
COMPRESSOR									
Number		2	2	2	2	2	2	2	2
Type		Screw							
INTERNAL HEAT EXCHANGER (EVAPORATOR)									
Number		1	1	1	1	1	1	1	1
Type		Shell & tube (Pure counterflow)							
Water connections	inch	5	5	6	6	6	6	6	6
EXTERNAL HEAT EXCHANGER (COILS)									
Number		6	6	8	8	8	8	9	10
Type		MCHX - Al/Alloy							
FAN									
Number		6	6	8	8	8	8	9	10
Air flow	m ³ /h	25.8	25.8	34.4	34.4	34.4	34.4	38.6	43.1
Total input power	kW	6.9	6.9	9.2	9.2	9.2	9.2	10.4	11.5
REFRIGERANT									
Type / GWP		R134a / 1430							
Charge 1 / 2 (1)	kg	21,5 / 21,5	26 / 26	30 / 30	29 / 36	33 / 37	33 / 33	36 / 42	40 / 40
	tCO ₂ ,eq	30,7 / 30,7	37,2 / 37,2	42,9 / 42,9	41,5 / 51,5	47,2 / 52,9	47,2 / 47,2	51,5 / 60,1	57,2 / 57,2
DESUPERHEATER									
Number		2	2	2	2	2	2	2	2
Type		PHE							
WEIGHT									
Shipping	kg	3.240	3.280	3.600	3.920	4.230	4.260	4.490	4.760
Operating	kg	3.350	3.380	3.760	4.080	4.390	4.410	4.640	4.900
DIMENSIONS									
Length	mm	4.600	4.600	4.600	4.600	4.600	4.600	5.700	6.700
Width	mm	2.200	2.200	2.200	2.200	2.200	2.200	2.200	2.200
Height	mm	2.510	2.510	2.510	2.510	2.510	2.510	2.510	2.510

(1) The refrigerant value are indicative values for standard units. The actual data are indicated on the unit label.

8 - Technical Data (continued)

S - Super Low Noise Version		650	720	800	850	910	970	1000
Power supply	V/Ph/Hz	400V/3/50Hz						
Number of refrigerant circuits		2	2	2	2	2	2	2
Start-up Type		SD	SD	SD	SD	SD	SD	SD
Total capacity steps	%	25-50-62-75-87-100						
COMPRESSOR								
Number		2	2	2	2	2	2	2
Type		Screw						
INTERNAL HEAT EXCHANGER (EVAPORATOR)								
Number		1	1	1	1	1	1	1
Type		Shell & tube (Pure counterflow)						
Water connections	inch	6	6	8	8	8	8	8
EXTERNAL HEAT EXCHANGER (COILS)								
Number		12	12	12	14	14	15	16
Type		MCHX - Al/Alloy						
FAN								
Number		12	12	12	14	14	15	16
Air flow	m ³ /h	51.7	51.7	51.7	60.3	60.3	64.6	68.9
Total input power	kW	13.8	13.8	13.8	16.1	16.1	17.3	18.4
REFRIGERANT								
Type / GWP		R134a / 1430						
Charge 1 / 2 (1)	kg	48 / 48	49 / 55	57 / 57	57 / 67	66 / 66	66 / 76	74 / 74
	tCO ₂ ,eq	68,6 / 68,6	70,1 / 78,7	81,5 / 81,5	81,5 / 95,8	94,4 / 94,4	94,4 / 108,7	105,8 / 105,8
DESUPERHEATER								
Number		2	2	2	2	2	2	2
Type		PHE						
WEIGHT								
Shipping	kg	5.180	5.600	6.090	6.620	6.700	6.920	7.010
Operating	kg	5.430	5.860	6.320	6.850	6.930	7.190	7.280
DIMENSIONS								
Length	mm	6.700	6.700	6.700	8.800	8.800	8.800	8.800
Width	mm	2.200	2.200	2.200	2.200	2.200	2.200	2.200
Height	mm	2.510	2.510	2.510	2.510	2.510	2.510	2.510

(1) The refrigerant value are indicative values for standard units. The actual data are indicated on the unit label.

8 - Technical Data (continued)

S - Super Low Noise Version		1070	1130	1170	1200	1300	1400
Power supply	V/Ph/Hz	400V/3/50Hz					
Number of refrigerant circuits		2	2	2	2	2	2
Start-up Type		SD	SD	SD	SD	SD	SD
Total capacity steps	%	25-50-62-75-87-100					
COMPRESSOR							
Number		2	2	2	2	2	2
Type		Screw					
INTERNAL HEAT EXCHANGER (EVAPORATOR)							
Number		1	1	1	1	1	1
Type		Shell & tube (Pure counterflow)					
Water connections	inch	8	8	8	8	10	10
EXTERNAL HEAT EXCHANGER (COILS)							
Number		17	18	19	20	22	24
Type		MCHX - Al/Alloy					
FAN							
Number		17	18	19	20	22	24
Air flow	m ³ /h	73.2	77.5	81.8	86.1	94.7	103.3
Total input power	kW	19.6	20.7	21.9	23.0	25.3	27.6
REFRIGERANT							
Type / GWP		R134a / 1430					
Charge 1 / 2 (1)	kg	73 / 83	83 / 83	79 / 92	89 / 89	96 / 104	102 / 102
	tCO ₂ ,eq	104,4 / 118,7	118,7 / 118,7	113,0 / 131,6	127,3 / 127,3	137,3 / 148,7	145,9 / 145,9
DESUPERHEATER							
Number		2	2	2	2	2	2
Type		PHE					
WEIGHT							
Shipping	kg	7.590	7.860	8.070	8.280	8.670	8.890
Operating	kg	7.980	8.250	8.450	8.660	9.040	9.345
DIMENSIONS							
Length	mm	9.900	10.900	10.900	10.900	12.000	13.000
Width	mm	2.200	2.200	2.200	2.200	2.200	2.200
Height	mm	2.510	2.510	2.510	2.510	2.510	2.510

(1) The refrigerant value are indicative values for standard units. The actual data are indicated on the unit label.

8 - Technical Data (continued)

HT - High Temperature Version		300	360	410	450	480	500	540	580
Power supply	V/Ph/Hz	400V/3/50Hz							
Number of refrigerant circuits		2	2	2	2	2	2	2	2
Start-up Type		PW	PW	PW	PW	PW	PW	PW	SD
Total capacity steps	%	25-50-62-75-87-100							
COMPRESSOR									
Number		2	2	2	2	2	2	2	2
Type		Screw							
INTERNAL HEAT EXCHANGER (EVAPORATOR)									
Number		1	1	1	1	1	1	1	1
Type		Shell & tube (Pure counterflow)							
Water connections	inch	5	5	6	6	6	6	6	6
EXTERNAL HEAT EXCHANGER (COILS)									
Number		6	6	8	8	8	8	9	10
Type		MCHX - Al/Alloy							
FAN									
Number		6	6	8	8	8	8	9	10
Air flow	m ³ /h	46.8	46.8	62.4	62.4	62.4	62.4	70.3	78.1
Total input power	kW	18.6	18.6	24.8	24.8	24.8	24.8	27.9	31.0
REFRIGERANT									
Type / GWP		R134a / 1430							
Charge 1 / 2 (1)	kg	21,5 / 21,5	26 / 26	30 / 30	29 / 36	33 / 37	33 / 33	36 / 42	40 / 40
	tCO ₂ ,eq	30,7 / 30,7	37,2 / 37,2	42,9 / 42,9	41,5 / 51,5	47,2 / 52,9	47,2 / 47,2	51,5 / 60,1	57,2 / 57,2
DESUPERHEATER									
Number		2	2	2	2	2	2	2	2
Type		PHE							
WEIGHT									
Shipping	kg	3.160	3.200	3.520	3.830	4.140	4.170	4.400	4.660
Operating	kg	3.270	3.300	3.670	3.990	4.290	4.320	4.550	4.800
DIMENSIONS									
Length	mm	4.600	4.600	4.600	4.600	4.600	4.600	5.700	6.700
Width	mm	2.200	2.200	2.200	2.200	2.200	2.200	2.200	2.200
Height	mm	2.510	2.510	2.510	2.510	2.510	2.510	2.510	2.510

(1) The refrigerant value are indicative values for standard units. The actual data are indicated on the unit label.

8 - Technical Data (continued)

HT - High Temperature Version		650	720	800	850	910	970	1000	
Power supply	V/Ph/Hz	400V/3/50Hz							
Number of refrigerant circuits		2	2	2	2	2	2	2	
Start-up Type		SD	SD	SD	SD	SD	SD	SD	
Total capacity steps	%	25-50-62-75-87-100							
COMPRESSOR									
Number		2	2	2	2	2	2	2	
Type		Screw							
INTERNAL HEAT EXCHANGER (EVAPORATOR)									
Number		1	1	1	1	1	1	1	
Type		Shell & tube (Pure counterflow)							
Water connections	inch	6	6	8	8	8	8	8	
EXTERNAL HEAT EXCHANGER (COILS)									
Number		12	12	12	14	14	15	16	
Type		MCHX - Al/Alloy							
FAN									
Number		12	12	12	14	14	15	16	
Air flow	m ³ /h	93.7	93.7	93.7	109.3	109.3	117.1	124.9	
Total input power	kW	37.2	37.2	37.2	43.4	43.4	46.5	49.6	
REFRIGERANT									
Type / GWP		R134a / 1430							
Charge 1 / 2 (1)	kg	48 / 48	49 / 55	57 / 57	57 / 67	66 / 66	66 / 76	74 / 74	
	tCO ₂ ,eq	68,6 / 68,6	70,1 / 78,7	81,5 / 81,5	81,5 / 95,8	94,4 / 94,4	94,4 / 108,7	105,8 / 105,8	
DESUPERHEATER									
Number		2	2	2	2	2	2	2	
Type		PHE							
WEIGHT									
Shipping	kg	5.080	5.500	5.990	6.510	6.600	6.810	6.900	
Operating	kg	5.330	5.760	6.220	6.750	6.830	7.090	7.180	
DIMENSIONS									
Length	mm	6.700	6.700	6.700	8.800	8.800	8.800	8.800	
Width	mm	2.200	2.200	2.200	2.200	2.200	2.200	2.200	
Height	mm	2.510	2.510	2.510	2.510	2.510	2.510	2.510	

(1) The refrigerant value are indicative values for standard units. The actual data are indicated on the unit label.

8 - Technical Data (continued)

HT - High Temperature Version		1070	1130	1170	1200		1300
Power supply	V/Ph/Hz	400V/3/50Hz					
Number of refrigerant circuits		2	2	2	2	2	2
Start-up Type		SD	SD	SD	SD	SD	SD
Total capacity steps	%	25-50-62-75-87-100					
COMPRESSOR							
Number		2	2	2	2	2	2
Type		Screw					
INTERNAL HEAT EXCHANGER (EVAPORATOR)							
Number		1	1	1	1	1	1
Type		Shell & tube (Pure counterflow)					
Water connections	inch	8	8	8	8	10	10
EXTERNAL HEAT EXCHANGER (COILS)							
Number		17	18	19	20	22	24
Type		MCHX - Al/Alloy					
FAN							
Number		17	18	19	20	22	24
Air flow	m ³ /h	132.7	140.5	148.3	156.1	171.7	187.3
Total input power	kW	52.7	55.8	58.9	62.0	68.2	74.4
REFRIGERANT							
Type / GWP		R134a / 1430					
Charge 1 / 2 (1)	kg	73 / 83	83 / 83	79 / 92	89 / 89	96 / 104	102 / 102
	tCO ₂ ,eq	104,4 / 118,7	118,7 / 118,7	113,0 / 131,6	127,3 / 127,3	137,3 / 148,7	145,9 / 145,9
DESUPERHEATER							
Number		2	2	2	2	2	2
Type		PHE					
WEIGHT							
Shipping	kg	7.490	7.760	7.970	8.180	8.570	8.890
Operating	kg	7.880	8.150	8.350	8.560	8.940	9.245
DIMENSIONS							
Length	mm	9.900	10.900	10.900	10.900	12.000	13.000
Width	mm	2.200	2.200	2.200	2.200	2.200	2.200
Height	mm	2.510	2.510	2.510	2.510	2.510	2.510

(1) The refrigerant value are indicative values for standard units. The actual data are indicated on the unit label.

8 - Technical Data (continued)

8.3 Unit electrical data

- Version			300	360	410	450	480	500	540	580	650	720	800	850	910	970	1000	1070	1130	1170	1200	1300	1400
Current input	Nominal	A	173	209	234	260	280	296	317	338	373	398	419	464	501	532	548	578	608	649	696	744	752
	Maximum	A	271	347	355	375	409	423	445	467	475	541	667	685	695	739	702	746	790	847	972	980	988
Power input	Nominal	kW	97	123	139	153	161	169	182	195	217	235	252	275	294	313	324	343	361	386	407	438	442
	Maximum	kW	167	203	207	221	245	255	268	281	285	309	373	406	435	455	438	458	478	512	592	596	600
Max Start-up current	A		437	608	616	650	775	789	811	559	567	697	822	951	961	1.029	968	1.036	1.080	1.239	1.442	1.450	1.458
UNIT (aM) FUSES	A		315	400	400	400	500	500	500	500	500	630	800	800	800	800	800	800	1.000	1.000	1.250	1.250	1.250
Phase WIRE SECTION*	mm ²		185	240	240	240	2 x 185	2 x 185	2 x 185	2 x 185	2 x 185	2 x 185	2 x 240	2 x 240	2 x 240	2 x 240	2 x 240	2 x 240	2 x 300	2 x 300	2 x 400	2 x 400	2 x 400

L/S Version			300	360	410	450	480	500	540	580	650	720	800	850	910	970	1000	1070	1130	1170	1200	1300	1400
Current input	Nominal	A	162	197	218	245	265	281	300	319	350	375	396	437	474	503	518	546	574	613	658	702	706
	Maximum	A	260	336	340	360	394	408	428	448	452	518	644	658	668	710	672	714	756	811	934	938	942
Power input	Nominal	kW	93	119	132	147	155	163	175	187	208	225	243	264	283	301	311	329	347	371	391	420	423
	Maximum	kW	163	199	201	215	239	249	261	273	275	299	363	394	423	443	426	445	464	497	576	578	580
Max Start-up current	A		426	597	601	635	760	774	794	540	544	674	799	924	934	1.000	938	1.004	1.046	1.203	1.404	1.408	1.412
UNIT (aM) FUSES	A		315	400	400	400	500	500	500	500	500	630	800	800	800	800	800	800	1.000	1.000	1.250	1.250	1.250
Phase WIRE SECTION*	mm ²		185	240	240	240	2 x 185	2 x 185	2 x 185	2 x 185	2 x 185	2 x 185	2 x 240	2 x 240	2 x 240	2 x 240	2 x 240	2 x 240	2 x 300	2 x 300	2 x 400	2 x 400	2 x 400

HT/HPF Version			300	360	410	450	480	500	540	580	650	720	800	850	910	970	1000	1070	1130	1170	1200	1300	1400
Current input	Nominal	A	179	214	241	268	287	303	325	347	384	409	430	476	513	545	563	594	624	666	714	764	773
	Maximum	A	277	353	362	382	416	430	453	476	486	552	678	697	707	752	717	762	806	864	990	1.000	1.009
Power input	Nominal	kW	105	131	148	163	171	179	193	207	232	249	267	292	311	331	343	363	383	409	431	464	471
	Maximum	kW	175	211	217	231	255	265	279	293	299	323	387	422	451	473	458	479	500	535	616	622	628
Max Start-up current	A		443	614	623	657	782	796	819	568	578	708	833	963	973	1.042	983	1.052	1.096	1.256	1.460	1.470	1.479
UNIT (aM) FUSES	A		315	400	400	400	500	500	500	500	500	630	800	800	800	800	800	800	1.000	1.000	1.250	1.250	1.250
Phase WIRE SECTION*	mm ²		185	240	240	240	2 x 185	2 x 185	2 x 185	2 x 185	2 x 185	2 x 185	2 x 240	2 x 240	2 x 240	2 x 240	2 x 240	2 x 240	2 x 300	2 x 300	2 x 400	2 x 400	2 x 400

(*) The dimensioning of the unit's power cables is the responsibility of the installer, who shall consider: the rating, the maximum working temperature in the room, the type of insulation and the cable laying, the maximum length of the power supply line.

8 - Technical Data (continued)

Compressors 400 V / 3 Ph / 50 Hz

Model	System	Compressor start mode	Power input nominal Cond. compressor (kW)	Nom. Cond. current compressor (A)	Power input max. Cond. compressor (kW)	Max. running current compressor FLA (A)	Starting current compressor LRA (A)	Carter oil 230Vac (W)
300	1	PW	43	75	78	124	290	200
	2		43	75	78	124	290	200
360	1	PW	56	93	96	162	423	200
	2		56	93	96	162	423	200
410	1	PW	62	101	96	162	423	200
	2		62	101	96	162	423	200
450	1	PW	62	101	96	162	423	200
	2		76	128	110	182	457	300
480	1	PW	69	117	110	182	457	300
	2		77	132	120	196	562	300
500	1	PW	77	132	120	196	562	300
	2		77	132	120	196	562	300
540	1	PW	77	132	120	196	562	300
	2		88	149	131	214	579	300
580	1	SD	88	149	131	214	306	300
	2		88	149	131	214	306	300
650	1	SD	97	163	131	214	306	300
	2		97	163	131	214	306	300
720	1	SD	97	163	131	214	306	300
	2		115	188	155	280	436	300
800	1	SD	115	186	175	310	465	300
	2		115	186	175	310	465	300
850	1	SD	115	186	175	310	465	300
	2		134	223	204	320	586	300
910	1	SD	134	223	204	320	586	300
	2		134	223	204	320	586	300
970	1	SD	134	223	204	320	586	300
	2		151	250	222	360	650	300
1000	1	SD	147	243	204	320	586	300
	2		147	243	204	320	586	300
1070	1	SD	147	243	204	320	586	300
	2		164	269	222	360	650	300
1130	1	SD	164	269	222	360	650	300
	2		164	269	222	360	650	300
1170	1	SD	164	269	222	360	650	300
	2		186	306	254	413	805	300
1200	1	SD	184	309	277	447	917	300
	2		184	309	277	447	917	300
1300	1	SD	198	329	277	447	917	300
	2		198	329	277	447	917	300
1400	1	SD	198	329	277	447	917	300
	2		198	329	277	447	917	300

8 - Technical Data (continued)

Fans - 400 V / 3 Ph / 50 Hz

Model	Standard fans 080 6 poli 400V-3-50		
	Number	Nominal power (kW) Δ	Max. running current (A) Δ
- Version			
300	6	1,9	3,9
360	6	1,9	3,9
400	8	1,9	3,9
430	8	1,9	3,9
460	8	1,9	3,9
490	8	1,9	3,9
540	9	1,9	3,9
580	10	1,9	3,9
650	12	1,9	3,9
720	12	1,9	3,9
800	12	1,9	3,9
850	14	1,9	3,9
910	14	1,9	3,9
970	15	1,9	3,9
1000	16	1,9	3,9
1070	17	1,9	3,9
1130	18	1,9	3,9
1170	19	1,9	3,9
1200	20	1,9	3,9
1300	22	1,9	3,9
1400	24	1,9	3,9
L/S Version			
300	6	1,1	2
360	6	1,1	2
400	8	1,1	2
430	8	1,1	2
460	8	1,1	2
490	8	1,1	2
540	9	1,1	2
580	10	1,1	2
650	12	1,1	2
720	12	1,1	2
800	12	1,1	2
850	14	1,1	2
910	14	1,1	2
970	15	1,1	2
1000	16	1,1	2
1070	17	1,1	2
1130	18	1,1	2
1170	19	1,1	2
1200	20	1,1	2
1300	22	1,1	2
1400	24	1,1	2
HT/HP Version			
300	6	3,1	4,8
360	6	3,1	4,8
400	8	3,1	4,8
430	8	3,1	4,8
460	8	3,1	4,8
490	8	3,1	4,8
540	9	3,1	4,8
580	10	3,1	4,8
650	12	3,1	4,8
720	12	3,1	4,8
800	12	3,1	4,8
850	14	3,1	4,8
910	14	3,1	4,8
970	15	3,1	4,8
1000	16	3,1	4,8
1070	17	3,1	4,8
1130	18	3,1	4,8
1170	19	3,1	4,8
1200	20	3,1	4,8
1300	22	3,1	4,8
1400	24	3,1	4,8

8 - Technical Data (continued)

8.4 Hydraulic features

Evaporator Available Pressure (Low head - Pump "A" & "B") Models 300-580

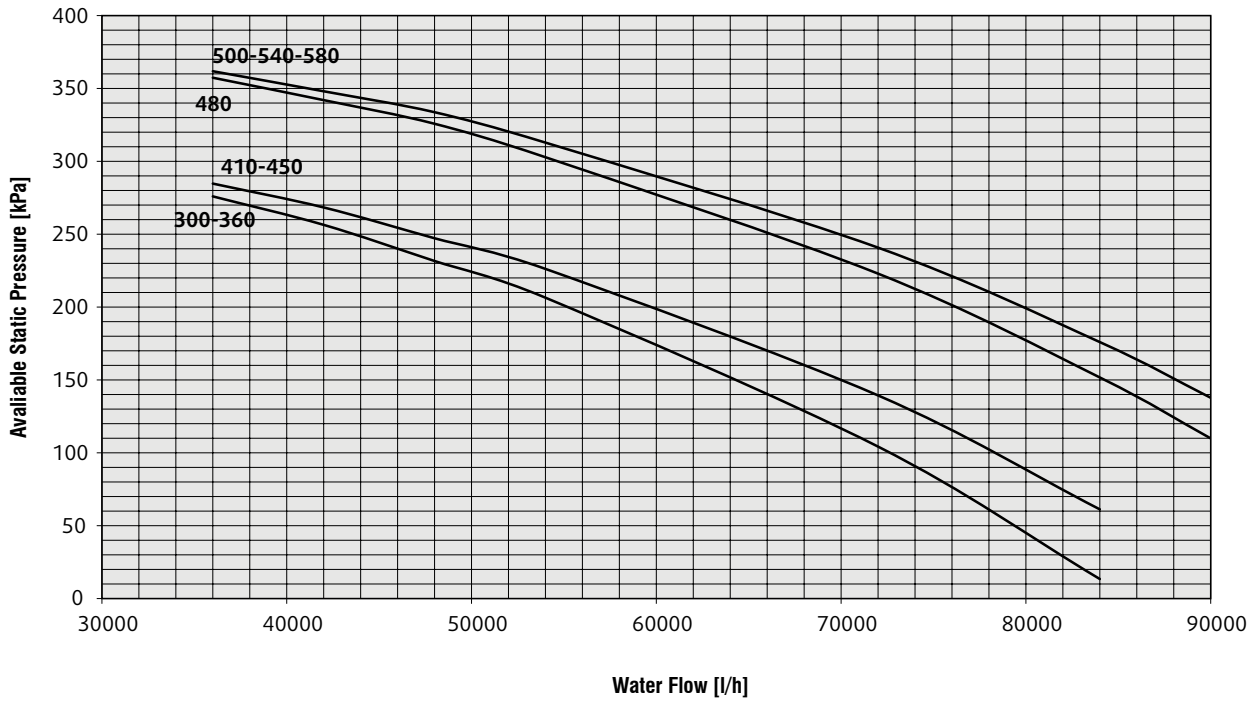

Available Pressure (Low head - Pump "C" & "D") Models 650-1070

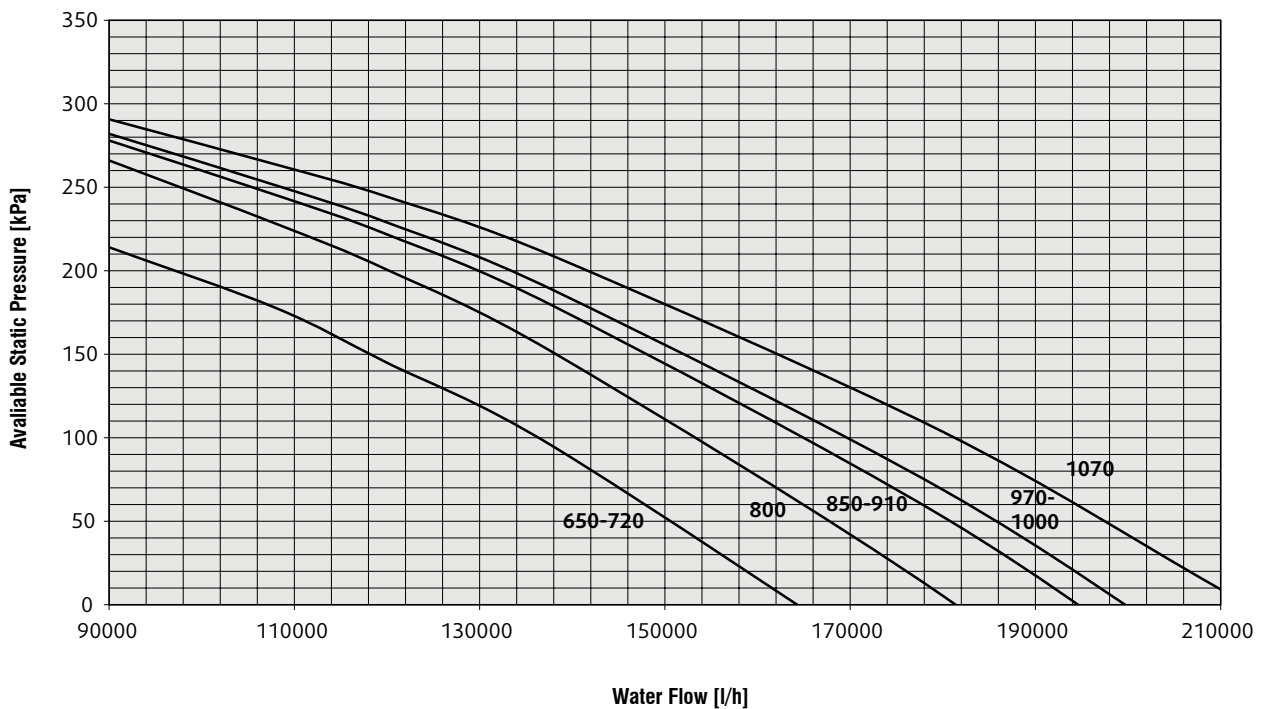

8 - Technical Data (continued)

Available Pressure (Low Head - Pump "E") Models 1130-1200

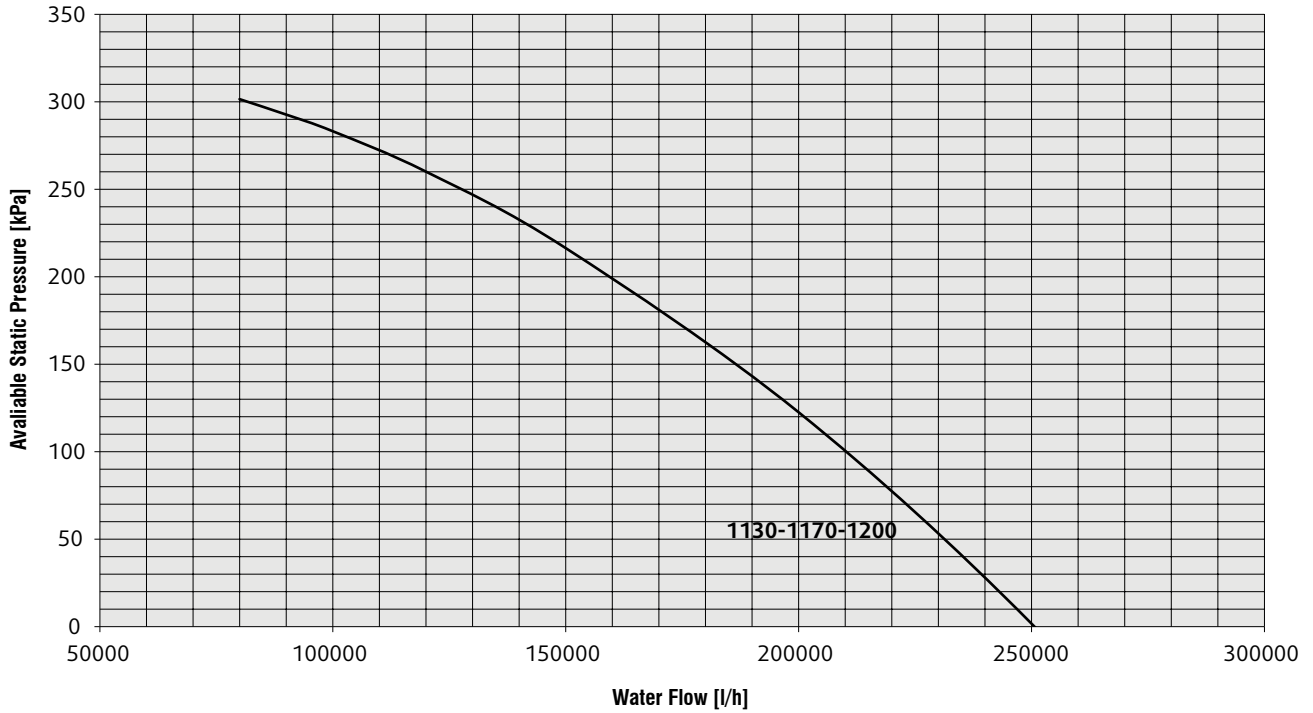

Available Pressure (High Head - Pump "F") Models 300-410

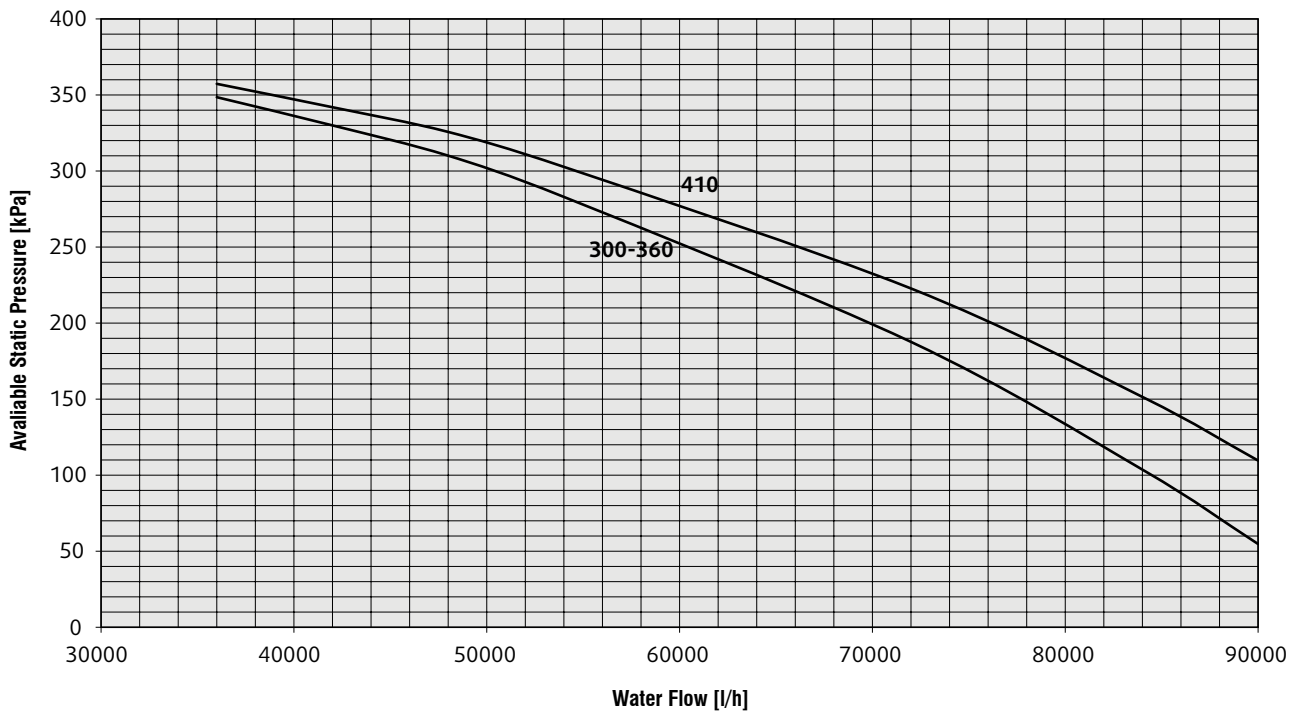

8 - Technical Data (continued)

Available Pressure (High Head - Pump "G" & "H") Models 450-720

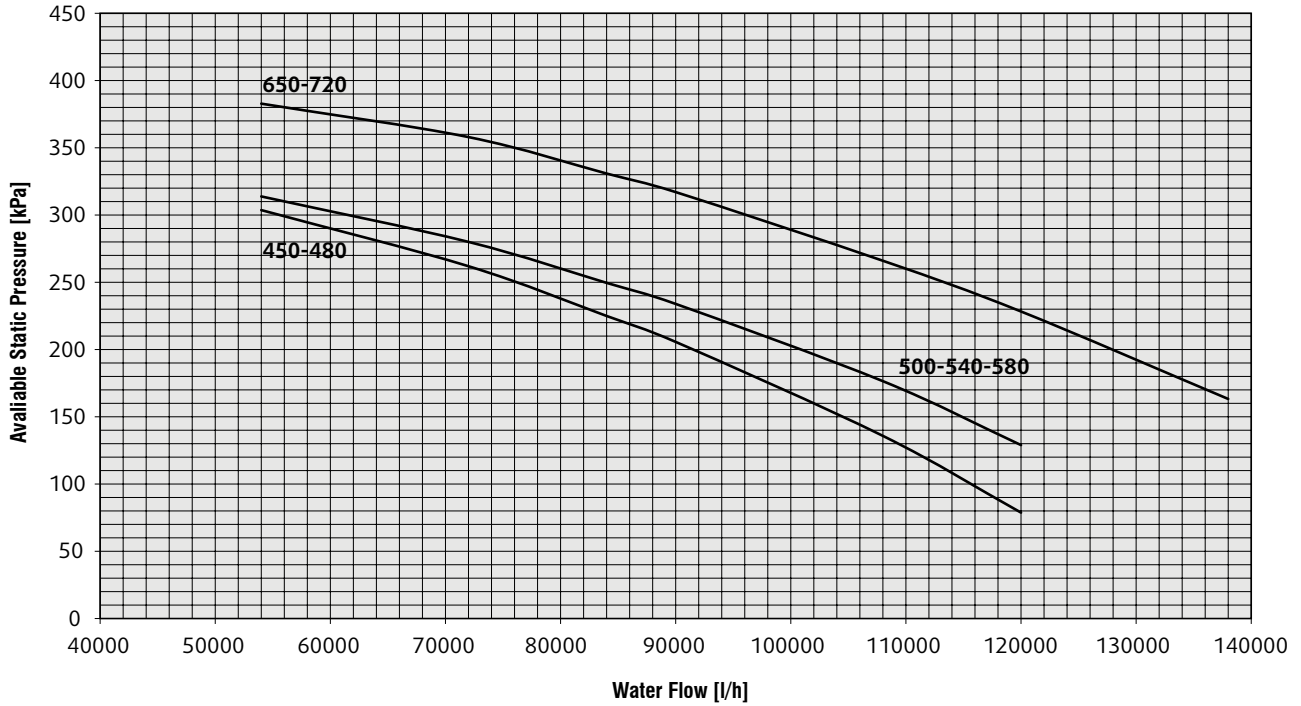

Available Pressure (High Head - Pump "I" & "J") Models 800-1070

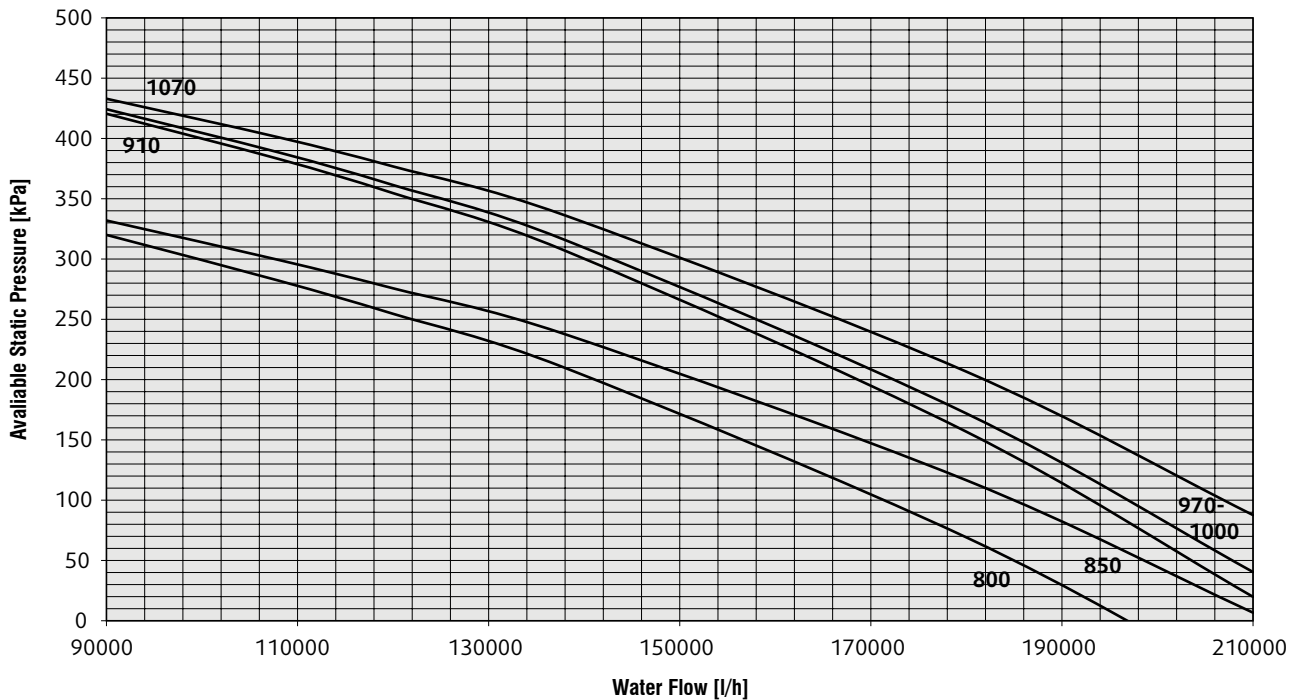

8 - Technical Data (continued)

Available Pressure (High Head - Pump "K") Models 1130-1200

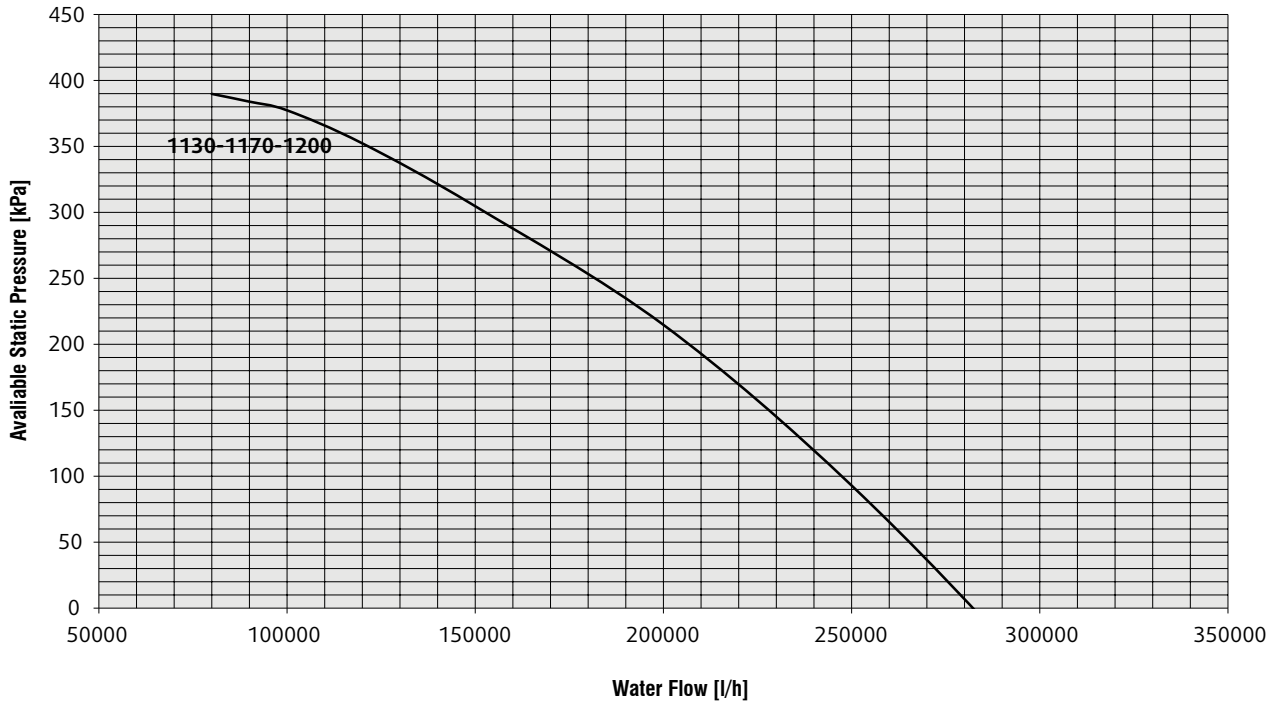

8 - Technical Data (continued)

8.5 Position of shock adsorbers and weight distribution on supports

Model	Weight distribution								Operating weight kg	Shipping weight kg	P coordinates				CG	
	F1	F2	F3	F4	F5	F6	F7	F8			a	b	c	d	x	y
	kg	kg	kg	kg	kg	kg	kg	kg			mm	mm	mm	mm	mm	mm
300 BLN/LN/HT	391	627	422	658	442	678	-	-	3.217	3.107	2.082	2.104	1.392	-	1.922	1.270
360 BLN/LN/HT	394	636	423	665	443	685	-	-	3.246	3.141	2.082	2.104	1.392	-	1.921	1.274
410 BLN/LN/HT	456	698	485	727	504	746	-	-	3.616	3.459	2.082	2.104	1.392	-	1.913	1.250
450 BLN/LN/HT	536	838	501	804	478	781	-	-	3.937	3.780	2.082	2.104	1.392	-	1.815	1.281
480 BLN/LN/HT	515	881	527	892	534	900	-	-	4.248	4.091	2.082	2.104	1.392	-	1.882	1.310
500 BLN/LN/HT	517	884	530	897	538	906	-	-	4.272	4.123	2.082	2.104	1.392	-	1.885	1.310
540 BLN/LN/HT	600	969	565	934	539	908	-	-	4.515	4.366	2.082	2.630	1.918	-	2.331	1.297
580 BLN/LN/HT	350	377	566	593	627	654	790	818	4.775	4.633	2.082	2.537	712	1.918	3.228	1.065
650 BLN/LN/HT	464	491	636	664	685	712	816	843	5.310	5.055	2.082	2.537	712	1.918	3.090	1.062
720 BLN/LN/HT	415	512	650	747	716	812	893	990	5.734	5.479	2.082	2.537	712	1.918	3.180	1.111
800 BLN/LN/HT	434	473	732	771	815	854	1.040	1.079	6.199	5.962	2.082	2.537	712	1.918	3.256	1.067
850 BLN/LN/HT	305	354	666	715	965	1.014	1.339	1.388	6.745	6.508	2.082	2.537	2.104	2.630	4.820	1.071
910 BLN/LN/HT	308	349	676	717	981	1.022	1.363	1.404	6.820	6.592	2.082	2.537	2.104	2.630	4.832	1.066
970 BLN/LN/HT	361	405	713	757	1.005	1.049	1.370	1.414	7.073	6.797	2.082	2.537	2.104	2.630	4.737	1.067
1000 BLN/LN/HT	376	417	727	768	1.019	1.059	1.383	1.424	7.173	6.897	2.082	2.537	2.104	2.630	4.719	1.065
1070 BLN/LN/HT	405	449	740	784	1.185	1.230	1.520	1.565	7.878	7.488	2.082	2.630	3.496	2.630	5.816	1.065
1130 BLN/LN/HT	445	487	816	857	1.215	1.256	1.515	1.556	8.146	7.756	2.082	3.249	3.496	2.630	6.247	1.062
1170 BLN/LN/HT	448	505	828	885	1.236	1.293	1.544	1.601	8.340	7.961	2.082	3.249	3.496	2.630	6.247	1.069
1200 BLN/LN/HT	450	495	850	895	1.281	1.327	1.605	1.651	8.554	8.175	2.082	3.249	3.496	2.630	6.288	1.063
1300 BLN/LN/HT	333	378	897	942	1.292	1.337	1.856	1.901	8.937	8.570	2.082	4.022	2.816	4.022	7.406	1.062
1400 BLN/LN/HT	434	479	991	1.036	1.329	1.374	1.811	1.856	9.310	8.943	2.082	4.641	2.816	4.022	7.696	1.061
300 ELN	399	649	428	678	447	697	-	-	3.298	3.188	2.082	2.104	1.392	-	1.918	1.278
360 ELN	402	658	430	686	448	704	-	-	3.327	3.222	2.082	2.104	1.392	-	1.916	1.282
410 ELN	464	721	491	747	509	765	-	-	3.697	3.540	2.082	2.104	1.392	-	1.909	1.257
450 ELN	544	861	508	825	484	801	-	-	4.023	3.866	2.082	2.104	1.392	-	1.813	1.287
480 ELN	524	904	534	914	541	921	-	-	4.338	4.181	2.082	2.104	1.392	-	1.880	1.315
500 ELN	526	908	537	919	545	927	-	-	4.362	4.213	2.082	2.104	1.392	-	1.882	1.314
540 ELN	610	994	572	956	544	928	-	-	4.605	4.456	2.082	2.630	1.918	-	2.327	1.301
580 ELN	349	377	575	603	638	666	809	837	4.854	4.712	2.082	2.537	712	1.918	3.241	1.065
650 ELN	462	491	645	673	696	724	834	863	5.389	5.134	2.082	2.537	712	1.918	3.104	1.063
720 ELN	414	512	658	756	727	825	912	1.010	5.813	5.558	2.082	2.537	712	1.918	3.192	1.111
800 ELN	433	473	741	780	827	867	1.059	1.099	6.279	6.042	2.082	2.537	712	1.918	3.266	1.067
850 ELN	303	353	672	722	978	1.028	1.360	1.410	6.825	6.588	2.082	2.537	2.104	2.630	4.833	1.072
910 ELN	306	347	682	724	994	1.036	1.385	1.426	6.900	6.672	2.082	2.537	2.104	2.630	4.844	1.066
970 ELN	358	404	719	764	1.018	1.063	1.391	1.436	7.153	6.877	2.082	2.537	2.104	2.630	4.750	1.067
1000 ELN	374	415	733	775	1.032	1.073	1.404	1.446	7.253	6.977	2.082	2.537	2.104	2.630	4.732	1.065
1070 ELN	403	448	745	790	1.199	1.245	1.541	1.587	7.958	7.568	2.082	2.630	3.496	2.630	5.830	1.065
1130 ELN	443	485	821	864	1.229	1.271	1.535	1.578	8.226	7.836	2.082	3.249	3.496	2.630	6.263	1.063
1170 ELN	446	504	834	892	1.250	1.308	1.564	1.622	8.420	8.041	2.082	3.249	3.496	2.630	6.262	1.070
1200 ELN	448	494	856	902	1.295	1.342	1.626	1.672	8.634	8.255	2.082	3.249	3.496	2.630	6.302	1.063
1300 ELN	329	376	903	949	1.305	1.351	1.879	1.925	9.017	8.650	2.082	4.022	2.816	4.022	7.421	1.062
1400 ELN	431	477	998	1.044	1.342	1.388	1.833	1.879	9.390	9.023	2.082	4.641	2.816	4.022	7.714	1.061

8 - Technical Data (continued)

8.6 Dimensional drawings - 4V 300-360-410-450-480-500

Front view

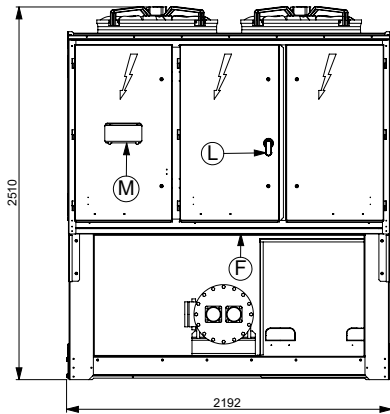

Side view

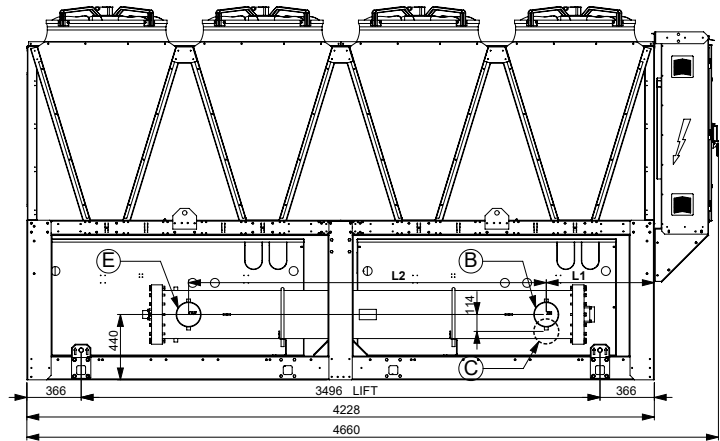

Back view

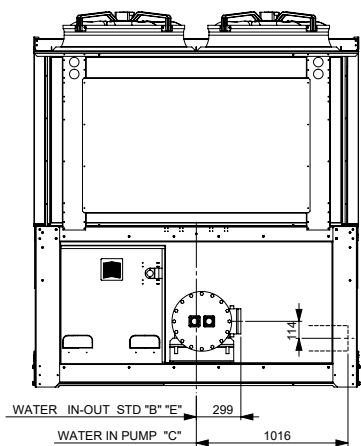

Top view

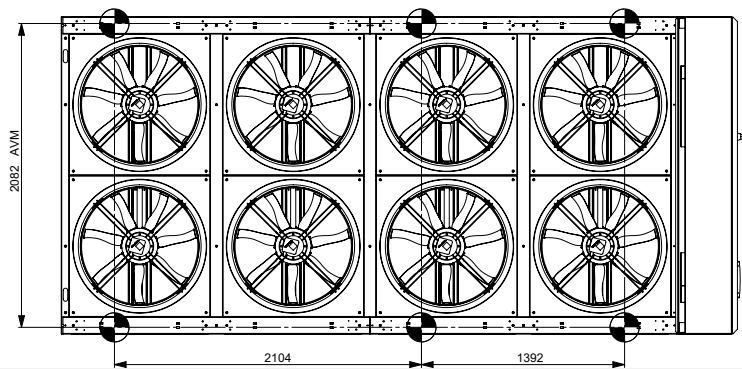

B, E	Water connection
F	Electrical power supply
L	Main switch
M	Control keypad / Display

Water connections	300-360	410-500
H	440	440
L1	722	725
L2	2.410	2.410

Hydraulic option	Water in	Water out
STD	B	E
B-E	300-360/5"	410-400/6"
1P/2P	5"	6"
Desuperheaters	2"	2"

8 - Technical Data (continued)

8.6 Dimensional drawings - 5V 540

Front view

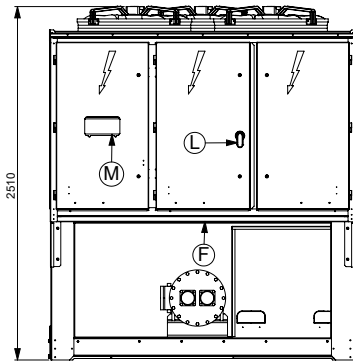

Side view

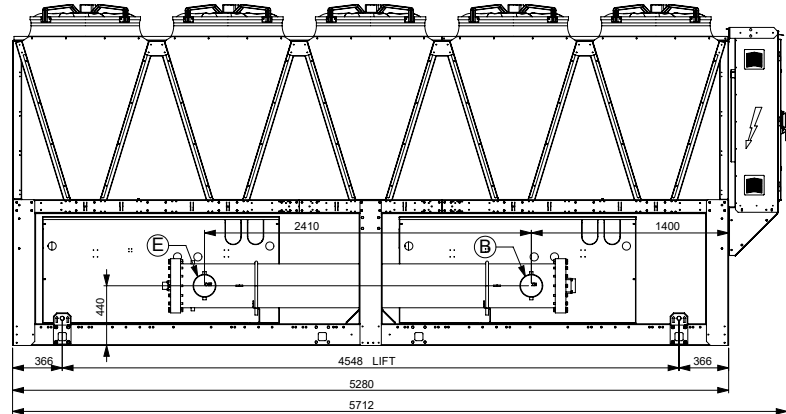

Back view

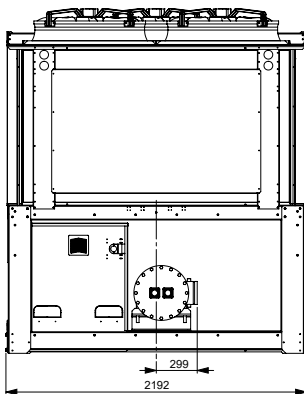

Top view

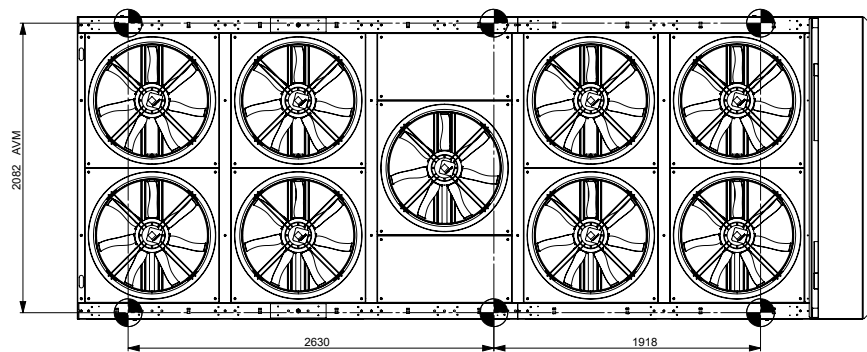

B, E	Water connection
F	Electrical power supply
L	Main switch
M	Control keypad / Display

Hydraulic option	Water in	Water out
STD	B	E
B-E	6"	6"
1P/2P	t.b.d.	t.b.d.
Desuperheaters	t.b.d.	t.b.d.

8 - Technical Data (continued)

8.6 Dimensional drawings - 6V 580-650-720-800

Front view

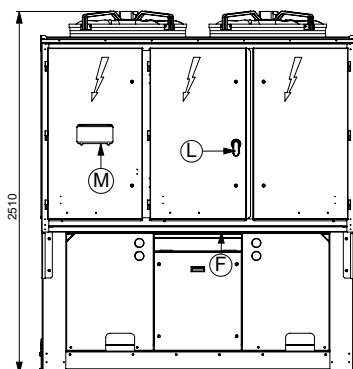

Side view

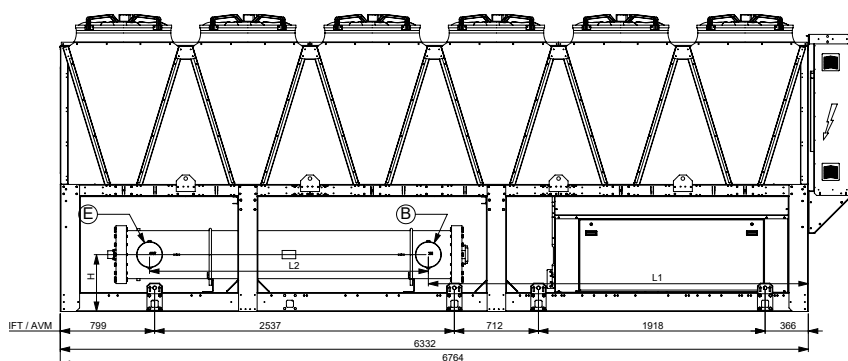

Back view

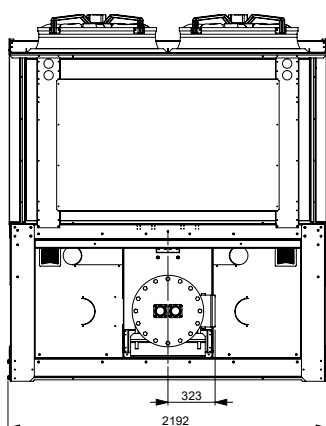

Top view

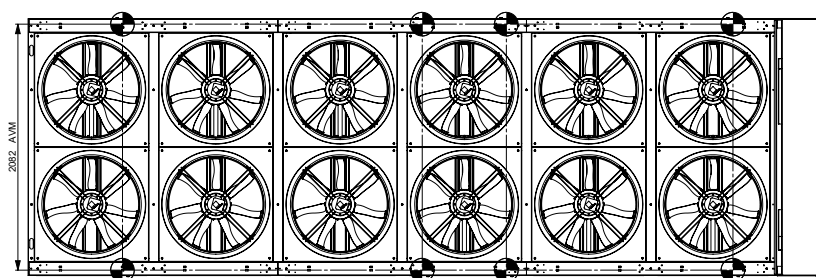

B, E	Water connection
F	Electrical power supply
L	Main switch
M	Control keypad / Display

Water connections	580	650-720-800
H	440	480
L1	2.852	2.881
L2	2.410	2.360

Hydraulic option	Water in	Water out
STD	B	E
B-E	6"	6" (800 8")
1P/2P	t.b.d.	t.b.d.
Desuperheaters	t.b.d.	t.b.d.

8 - Technical Data (continued)

8.6 Dimensional drawings - 8V 850-910-970-1000

Front view

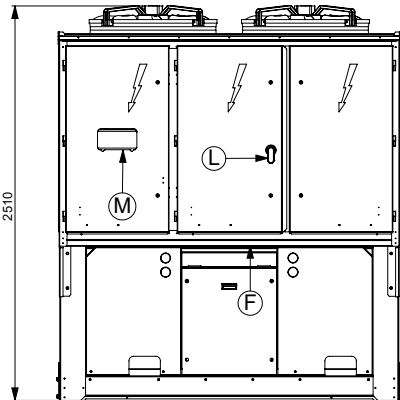

Side view

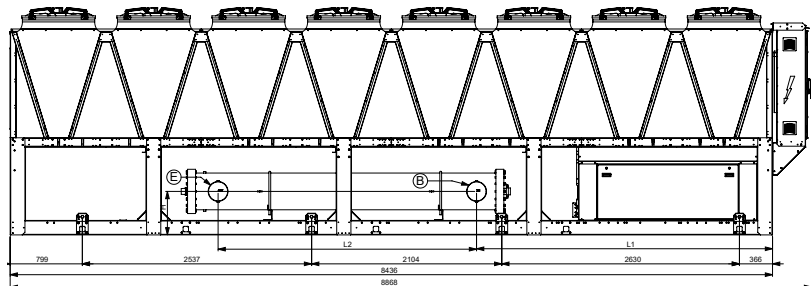

Back view

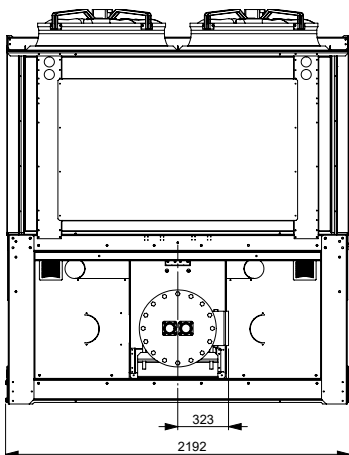

Top view

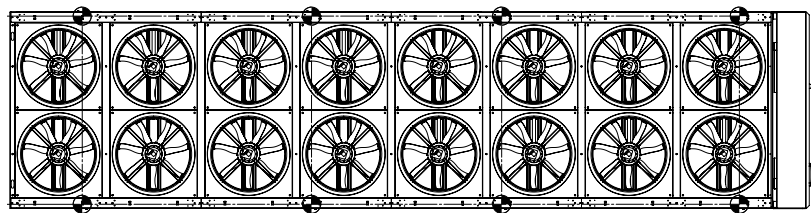

B, E	Water connection
F	Electrical power supply
L	Main switch
M	Control keypad / Display

Water connections	850-910	970-1000
H	480	530
L1	3.344	3.379
L2	2.360	2.860

Hydraulic option	Water in	Water out
STD	B	E
B-E	8"	8"
1P/2P	t.b.d.	t.b.d.
Desuperheaters	t.b.d.	t.b.d.

8 - Technical Data (continued)

8.6 Dimensional drawings - 9V 1070

Front view

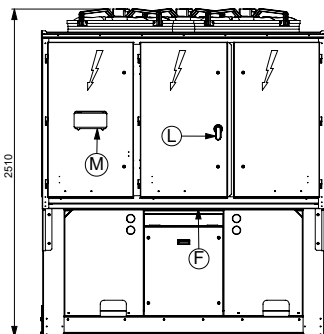

Side view

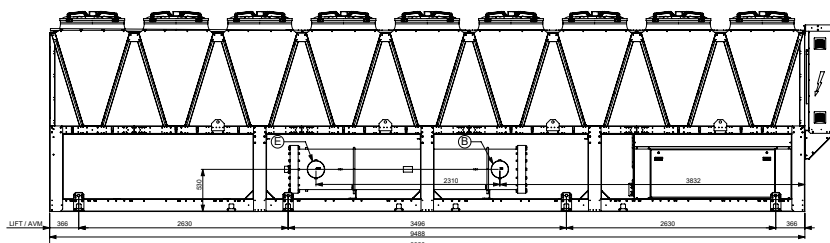

Back view

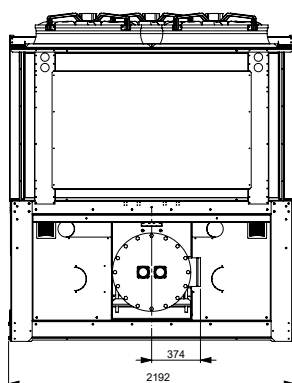

Top view

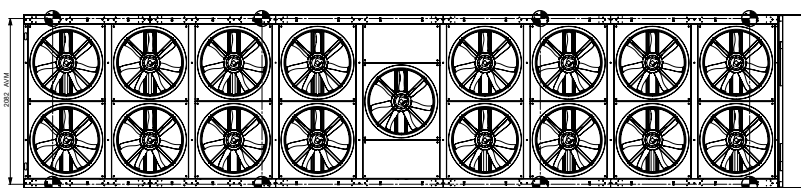

B, E	Water connection
F	Electrical power supply
L	Main switch
M	Control keypad / Display

Hydraulic option	Water in	Water out
STD	B	E
B-E	8"	8"
1P/2P	t.b.d.	t.b.d.
Desuperheaters	t.b.d.	t.b.d.

8 - Technical Data (continued)

8.6 Dimensional drawings - 10V 1130-1170-1200

Front view

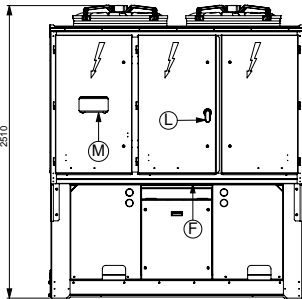

Side view

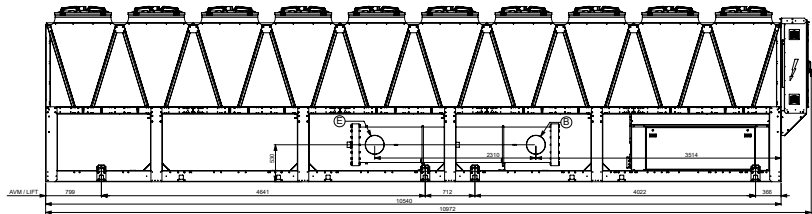

Back view

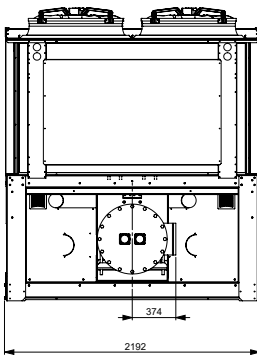

Top view

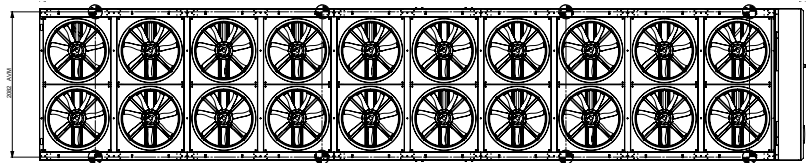

B, E	Water connection
F	Electrical power supply
L	Main switch
M	Control keypad / Display

Hydraulic option	Water in	Water out
STD	B	E
B-E	8"	8"
1P/2P	t.b.d.	t.b.d.
Desuperheaters	t.b.d.	t.b.d.

8 - Technical Data (continued)

8.6 Dimensional drawings - 11V 1300

Front view

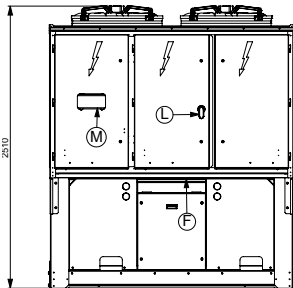

Side view

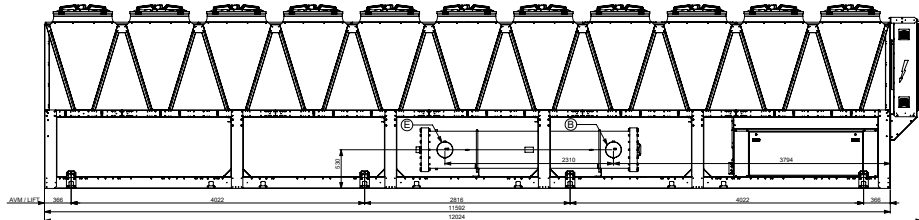

Back view

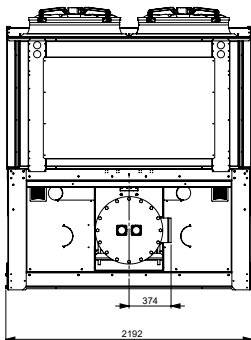

Top view

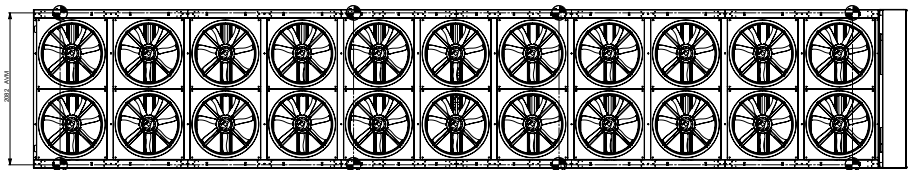

B, E	Water connection
F	Electrical power supply
L	Main switch
M	Control keypad / Display

Hydraulic option	Water in	Water out
STD	B	E
B-E	8"	8"
1P/2P	t.b.d.	t.b.d.
Desuperheaters	t.b.d.	t.b.d.

8 - Technical Data (continued)

8.6 Dimensional drawings - 12V 1400

Front view

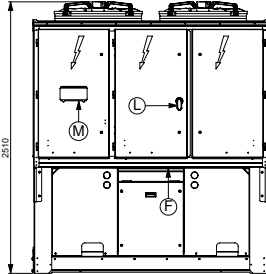

Side view

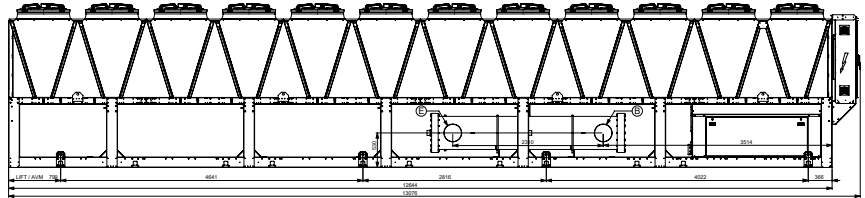

Back view

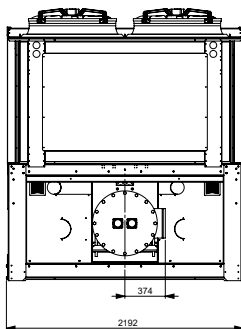

Top view

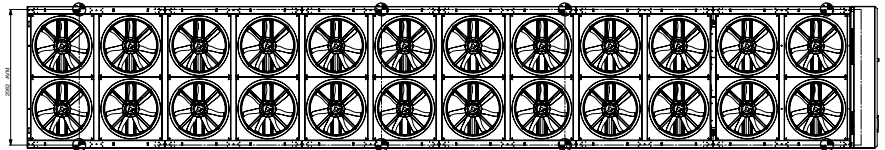

B, E	Water connection
F	Electrical power supply
L	Main switch
M	Control keypad / Display

Hydraulic option	Water in	Water out
STD	B	E
B-E	10"	10"
1P/2P	t.b.d.	t.b.d.
Desuperheaters	t.b.d.	t.b.d.

8 - Technical Data (continued)

8.7 Service spaces

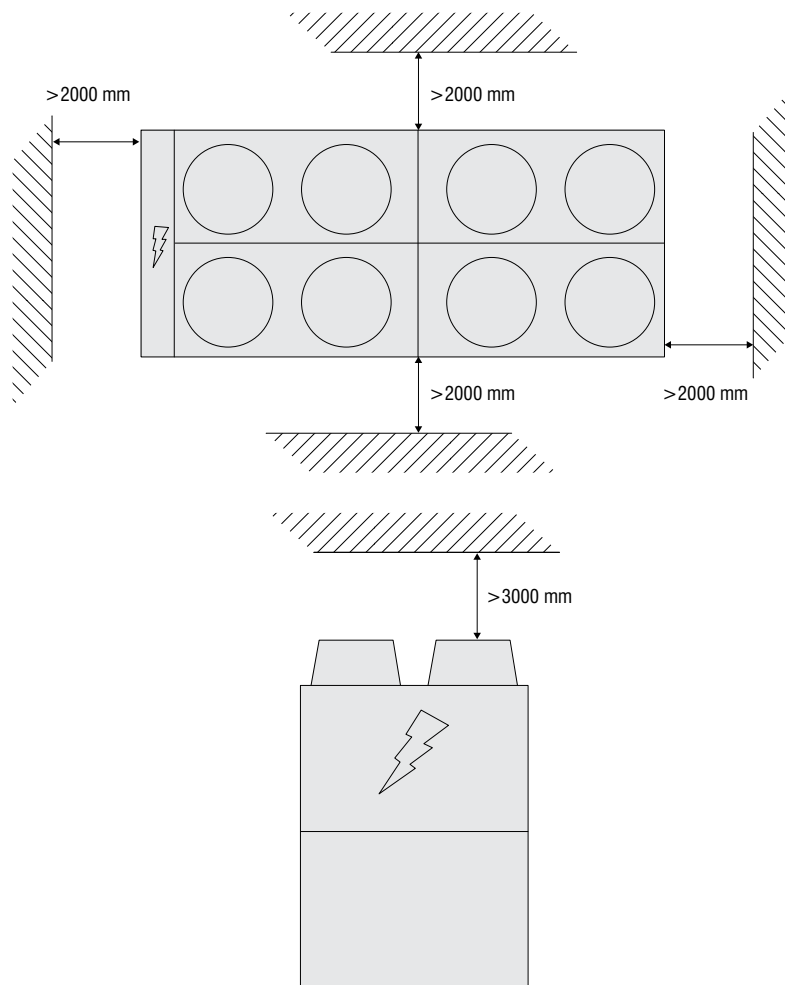

9 - Maintenance

Carefully read the “Safety” section of this manual before carrying out any maintenance operations.

	<p>Do not discharge the refrigerant into the atmosphere while the refrigeration circuits are being drained. Use appropriate recovery equipment.</p> <p>When the recovered refrigerant cannot be re-used, return it to the manufacturer.</p>
---	---

	<p>Do not throw away the waste oil of the compressor, because it contains refrigerant in solution.</p> <p>The waste oil must be returned to the manufacturer.</p>
---	---

Unless otherwise specified, the operations described below may be carried out only by a trained maintenance operator.

9.1 General requirements

Units have been designed for continuous operation, providing that they are subjected to regular maintenance, within the limits specified in this manual. Each unit must be serviced according to the programme by the User/Customer, and must be inspected at regular intervals by the personnel of one authorised Service Centers.

It is the responsibility of the User to meet these maintenance requirements and/or to enter into an agreement with one of authorised Service Centers, so as to properly safeguard the operation of the appliance.

During the warranty period, in case of damage or failures caused by improper maintenance, manufacturer will not refund the costs incurred to repair the appliance in its original state.

The provisions of this section apply only to standard units; according to the order requirements, other documentation may be added, concerning any modifications or supplementary accessories.

9.2 Planned maintenance

Maintenance inspections must be carried out according to the program below, by a qualified person.

As a general rule, units cannot be repaired directly by the user, who shall not try to service or repair any failures or anomalies identified during daily inspections. If you are in doubt, please contact authorised Service Centre.

Operations	Daily	Weekly	Monthly	Beginning of season	End of season
Check the temperature of the leaving fluid	●				
Check the pressure drops in the heat exchanger		●			
Check for electric absorption		●			
Check suction pressure and temperature		●			
Check delivery pressure and temperature		●			
Check the oil level in the compressor		●			
Check that there are no gas bubbles in the liquid line		●			
Check that the fins of the external coil are clean (if any)			●		
Check the operation of the oil heaters			●		
Check the remote control switches			●		
Check the operation of the LP pressure switch				●	
Check the operation of the HP pressure switch				●	
Check the insulation of the heat exchanger				●	
Check that terminals are tightened				●	
Check that the terminals' screws are tightened				●	
Clean the exterior of the unit with water and soap				●	
Check the density of the antifreeze (if any)				●	●
Check the operation of the flow switches				●	
Check the operation of the solenoid valve				●	●

9 - Maintenance (continued)

9.3 Refrigerant charge

	<p>Do not inject refrigerant liquid into the LP side of the circuit. Be very careful, and charge the circuit properly.</p> <p>If the charge is insufficient, the efficiency of the unit will be lower than expected. In the worst of cases the LP pressure switch may be activated, resulting in the halting of the unit.</p> <p>In the presence of an excess charge, the condensing pressure will rise (in the worst of cases, the HP pressure switch may be activated, resulting in the stop of the equipment), and the consumption will increase as well.</p>
---	---

	<p>It is strictly forbidden to use the compressor as a vacuum pump to drain the plant.</p>
---	---

Fill the refrigeration circuit after it has been drained for maintenance purposes (leaks, replacement of the compressor etc.). The amount of the charge is indicated on the plate affixed to the unit.

Before refilling, it is important to drain and de-hydrate the circuit, thus obtaining a minimum abs. pressure value of 0.06 mbar.

Inject the refrigerant fluid before removing the vacuum, then fill the circuit up to 90% of the total gas requirement (in liquid form). The appliance must be filled through the filling valve on the liquid line, on the outlet side of the condenser.

It is recommended to connect the refrigerant cylinder to the filling valve on the liquid line, and to arrange it in such a way as to inject only liquid refrigerant.

Then start the compressor and let the gas flow from the cylinder, up until the liquid flow, which can be observed through the sight glass, is limpid.

9.4 Compressor

Compressors are delivered with the necessary charge of lubricating oil. During normal operation, this charge is sufficient for the whole life of the unit, providing that the efficiency of the refrigeration circuit is satisfactory and if it has not been overhauled.

If the compressor needs to be replaced (following a mechanical failure or if burnt), contact one of manufacturer.

	<p>Compressors use polyester oil. During maintenance operations on the compressor, or if you have to open the refrigerant circuit in any point, remember that this type of oil is highly hygroscopic, and accordingly it is important that it is not left exposed to the weather for prolonged periods, as this would require the replacement of the oil.</p>
---	--

9.5 Condenser

The condenser's coils are of microchannel type made of 100% aluminium (fins and tubes). In the presence of leaks caused by any damage or shock, the coils shall be repaired or replaced by one authorised Service Center. To ensure the effective and correct operation of the condenser coils, it is important to keep the condenser's surface perfectly clean, and to check that there is no foreign matter, such as leaves, wires, insects, waste etc. If the coil becomes dirty, there is an increase in the absorption of electric energy. Furthermore, the maximum pressure alarm may be activated and may halt the unit.

	<p>Be careful not to damage the aluminium fins during cleaning.</p>
--	--

The condenser must be cleaned with a LP compressed air jet, parallel to the aluminium fins, in the direction opposite to the air circulation.

To clean the coil you can use also a vacuum cleaner, or a jet of water and soap.

9.6 Fans

The fans of the condenser, of axial type, are complete with impeller with aerodynamic profile blades and a cylindrical nozzle. The motor's bearings are lubricated forever.

Before starting the appliance, after any maintenance operations involving the disconnection of 3-phase connections, check that the direction of rotation of the fans is the one indicated by the arrow (upward air current). If the direction of rotation is wrong, invert two of the three supply phases to the motor.

9.7 Dehydrating filter

The refrigeration circuits are provided with dehydrating filters.

The filter clogging is marked by the presence of air bubbles in the sight glass, or by the difference between the temperatures measured downstream from and upstream of the drying filter. If, once the cartridge has been cleaned, there are still some air bubbles, the appliance has lost a part of the refrigerant charge in one or more points, that must be identified and serviced.

9 - Maintenance (continued)

9.8 Sight glass

The sight glass is used for inspecting the refrigerant flow and the humidity % of the refrigerant. The presence of bubbles indicates that the dehydrating filter is clogged or the charge insufficient.

A colour indicator is positioned inside the sight glass. If you compare the colour of the indicator to the scale on the ring of the sight glass, you can calculate the percentage of humidity of the refrigerant. If it is excessive, replace the filter's cartridge, operate the appliance for 1 day and then check the humidity % again. When the humidity % is within the pre-determined range, no other operations are required. If the humidity % is still too high, replace the dehydrating filter again, start the unit and operate it for another day.

9.9 Electronic expansion valve

The circuit of the unit is equipped with electronic expansion valve.

The valve is calibrated for an overheating of 6 °C.

Procedure to check for overheating:

- Measure the suction pressure with the pressure gauges on the board of the unit or using a pressure gauge connected to the service valve on the suction side.
- From the pressure gauge's temperature scale, measure the saturated suction temperature (T_{sa}) which corresponds to the pressure value.
- Using a contact pressure gauge affixed to the outlet fitting of the gas of the evaporator, measure the actual temperature (T_{se}).

Overheating calculation (S):

$$S = T_{se} - T_{sa}$$

Overheating is regulated through the expansion valve.

If the electronic expansion valve cannot be regulated, it is probably broken, and shall be replaced. The replacement must be carried out by a Service Centre.

9.10 Evaporator

Check at regular intervals that the water side of the heat exchanger is perfectly clean. To do this, measure the pressure drop, water side (see Section 8) or measure the temperature of the liquid leaving and entering the heat exchanger, and compare it to the evaporation temperature.

To obtain an effective heat exchange, the difference between the temperature of the leaving water and the saturated evaporating temperature must be in the 2 - 4 °C range. A greater difference would indicate a low efficiency of the heat exchanger (i.e. the heat exchanger is dirty).

In this case, the heat exchanger must be subjected to chemical cleaning, an operation that shall be carried out by authorised engineers.

For other maintenance operations (extraordinary overhauling, replacement of the heat exchanger etc.), contact an authorised Service Centre.

10 - Troubleshooting

The table below lists the anomalies of operation of the unit, the relevant causes and the corrective measures. For anomalies of any other type or not listed, contact one of authorised Service Centre for technical assistance.

Anomaly	Cause	Operation
The unit continues to work, but without cooling	Insufficient charge of refrigerant.	Refill.
	The dehydrating filter is clogged.	Replace.
Ice on the suction line	Wrong calibration of overheating.	Increase overheating.
		Check the charge.
Excessive noise	Vibration of lines.	Check the clamping brackets, if any.
	Whistler emitted by the thermostatic expansion valve.	Refill.
		Check the dehydrating filter.
	Noisy compressor.	Seized bearings; replace the compressor.
Check that the compressor's locknuts are tightened.		
Low oil level in the compressor	One or more gas or oil leaks in the circuit.	Identify and remove leaks.
	Mechanical failure of the compressor.	Request the intervention of a Service Centre.
	Anomaly of the oil heater of the compressor's base.	Check the electric circuit and the resistor of the heater of the motor base, and replace defective components.
One or both compressors are not working	Breaking of the electric circuit.	Check the electric circuit and detect any ground dispersions and short circuits. Check fuses.
	Intervention of the HP pressure switch.	Reset the pressure switch and the control panel and restart the appliance. Identify and remove the cause that enabled the pressure switch.
	The fuse of the control circuit is broken.	Check for ground dispersions and short circuits. Replace fuses.
	Loosened terminals.	Check and tighten.
	Halt caused by thermal overload of the electric circuit.	Check the operation of check and safety devices. Identify and remove the cause.
	Wrong wiring.	Check wiring of check and safety devices.
	The line voltage is too low.	Check voltage. If problems regard the system, solve them. If they are caused by the distribution network, inform the Energy Distributor.
	Short-circuit of the compressor's motor.	Check the continuity of the winding.
Seized compressor.	Replace the compressor.	
Activation of the LP alarm, stop of the unit	Gas leak.	Identify and remove the leak.
	Insufficient charge.	Refill.
	Failure of the pressure switch.	Replace the pressure switch.
Activation of the HP alarm, stop of the unit	Failure of the pressure switch.	Check the operation of the pressure switch, replace it if defective.
	The delivery valve is partially closed.	Open the valve and replace it, if faulty.
	Substances with condensable gases in the circuit.	Drain the circuit.
	The fan of the condenser is stopped.	Check cables and motor. If defective, repair or replace.
The liquid line is too hot	Insufficient charge.	Identify and remove the cause of the loss of charge and refill.
Frosting of the liquid line	The valve of the liquid line is partially closed.	Check that valves are open.
	The liquid filter is clogged.	Replace the cartridge or the filter.

11 - Spare Parts

11.1 Spare part list

The table below shows the list of spare parts recommended during the first two years of operation.

Component	Number
HP pressure switch	1
LP pressure switch	1
Gas filter	2
Electronic expansion valve	2
Auxiliary relays	2
Fan's fuses	6
Compressor's fuses	6
Auxiliary fuses	6
Set of compressor contactors	1
Fan's contactor	1
Water sensor	1
Air sensor	1
Electronic card	1
Keyboard	1
Compressor oil resistor	1

11.2 Oil for compressors

The compressors are lubricated with Ester oil BSE 170 (Viscosity of 170 St / 40 °C).

11.3 Wiring diagrams

The wiring diagrams are installed inside the doors of the electrical panels of the unit. Any request for wiring diagrams shall be forwarded to manufacturer's Service Centre.

12 - Dismantling, Demolition and Scrapping



During the draining of the refrigeration circuits, do not let the refrigerant overflow in the surrounding atmosphere.

The circuit must be drained using suitable recovery equipment.



Do not disperse the waste oil of the compressors in the environment, since it contains some dissolved refrigerant.

For the disposal, contact the competent authority for information.

Unless otherwise specified, the maintenance operations listed below may be carried out by any trained maintenance operator.

12.1 Generalities

Open each line that supplies the unit, including the ones of control circuits. Make sure that all disconnecting switches are secured in the off position. The power cables can be disconnected and disassembled. Refer to Chapter 4 for the position of connection points.

Remove all the refrigerant from the refrigeration circuits of the unit and store it in suitable containers, using a recovery unit. If its characteristics have remained the same, the refrigerant can be used again. Contact the competent authority to obtain information about disposal. In **NO** event shall the refrigerant be discharged into the atmosphere. The oil in each refrigeration circuit must be drained and collected into a suitable container; then it shall be disposed of in conformity with local regulations that apply to the disposal of waste lubricants. Any oil spillage must be recovered and disposed of in like manner.

Isolate the unit's heat exchangers from the external hydraulic circuits and drain the heat exchange sections of the plant.



If no shutoff valves have been provided, it may be necessary to drain the whole plant.

If a glycoled solution or a similar fluid has been used in the hydraulic circuits, or if chemical additives have been added to the circulating water, the circulating fluid MUST be drained in a proper way.

For NO reason shall a circuit containing glycoled water or a similar solution be discharged directly into the drains or surface waters.

After draining operations, the piping of the hydraulic networks can be disconnected and disassembled.

Once they have been disconnected as specified, the packaged units can be disassembled in a single piece. First of all, disassemble the anchoring screws and then lift the unit from the position of installation, and hook it to the lifting points provided, using suitable lifting equipment.

To this end, refer to Chapter 4 for the installation of these appliances, to Chapter 8 for their weights and Chapter 3 for handling.

The units that, once disconnected, cannot be removed in a single piece, must be dismantled on site; in this case, be very careful with the weight and handling of every single component.

It is always advisable to dismantle the units following the installation steps, but in reverse.



Some residues of oil, glycoled water or similar solutions may remain in certain parts of the unit. These residues must be recovered and disposed of according to the procedures specified above.

It is very important to ensure that, while a component of the unit is being removed, all the others are properly supported.



Use only lifting means of adequate capacity.

Once disassembled, the components of the unit can be disposed of in conformity with current regulations.

12.2 RAEE Directive (only UE)



- The RAEE Directive requires that the disposal and recycling of electrical and electronic equipment must be handled through a special collection, in appropriate centers, separate from that used for the disposal of mixed urban waste.
- The user has the obligation not to dispose of the equipment at the end of the useful life as municipal waste, but to send it to a special collection center.
- The units covered by the RAEE Directive are marked with the symbol shown above.
- The potential effects on the environment and human health are detailed in this manual.

Systemair srl
Via XXV Aprile, 29
20825 Barlassina (MB)
Italy

Tel. +39 0362 680 1
Fax +39 0362 680 693

www.systemair.com

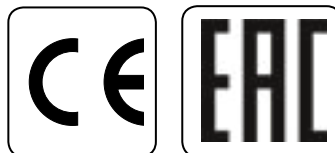

As part of our ongoing product improvement programme, our products are subject to change without prior notice. Non contractual photos.

Dans un souci d'amélioration constante, nos produits peuvent être modifiés sans préavis. Photos non contractuelles.

In dem Bemühen um ständige Verbesserung können unsere Erzeugnisse ohne vorherige Ankündigung geändert werden. Fotos nicht vertraglich bindend.

A causa della politica di continua miglioria posta in atto dal costruttore, questi prodotti sono soggetti a modifiche senza alcun obbligo di preavviso. Le foto pubblicate non danno luogo ad alcun vincolo contrattuale.

Con objeto de mejorar constantemente, nuestros productos pueden ser modificados sin previo aviso. Fotos no contractuales.

