

## BEDIENUNG UND INSTALLATION OPERATION AND INSTALLATION

Sole | Wasser-Wärmepumpe | Brine | water heat pump

- » WPE-I 33 H 400 Premium
- » WPE-I 44 H 400 Premium
- » WPE-I 59 H 400 Premium
- » WPE-I 87 H 400 Premium

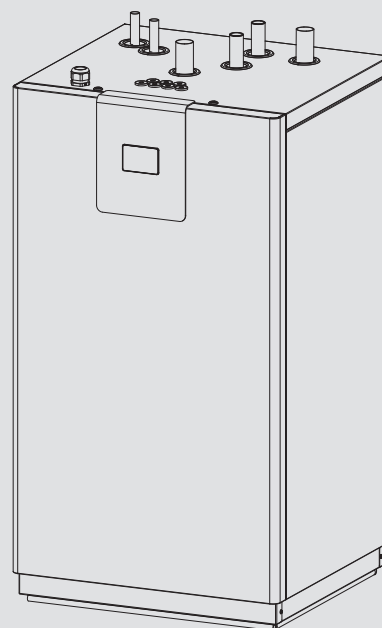

**STIEBEL ELTRON**

# CONTENTS

## SPECIAL INFORMATION

### OPERATION

<b>1. General information</b>	<b>48</b>
1.1 Relevant documents	48
1.2 Safety instructions	48
1.3 Other symbols in this documentation	48
1.4 Units of measurement	48
1.5 Standardised output data	48
<b>2. Safety</b>	<b>49</b>
2.1 Intended use	49
2.2 Safety instructions	49
2.3 Test symbols	49
<b>3. Appliance description</b>	<b>49</b>
<b>4. Operation</b>	<b>49</b>
<b>5. Maintenance and care</b>	<b>49</b>
<b>6. Troubleshooting</b>	<b>49</b>
6.1 Other problems	49

### INSTALLATION

<b>7. Safety</b>	<b>50</b>
7.1 General safety instructions	50
7.2 Instructions, standards and regulations	50
<b>8. Appliance description</b>	<b>50</b>
8.1 Standard delivery	50
8.2 Accessories	50
<b>9. Preparation</b>	<b>50</b>
9.1 Sound emissions	50
9.2 Minimum clearances	51
9.3 Preparation of the installation site	51
9.4 Wall outlet	52
9.5 Preparing the electrical installation	53
<b>10. Installation</b>	<b>53</b>
10.1 Transport	53
10.2 Siting	53
10.3 Removing the casing parts	53
10.4 Installing the heat source system	54
10.5 Flow and return connection	54
10.6 Oxygen diffusion	54
10.7 Filling the heating system	55
10.8 DHW heating	55
10.9 Operation with buffer cylinder	55
<b>11. Electrical connection</b>	<b>56</b>
11.1 General	56
11.2 Checks before electrical connection	56
11.3 Access to the terminal area	56
11.4 Terminal area	56
11.5 Dynamic allocation	56
11.6 Electrical connection	57
11.7 Sensor installation	57
11.8 High limit safety cut-out for STB-FB area heating system	57
11.9 Internet Service Gateway ISG	57
11.10 Termination at both ends of the accessories and building management system communication network	57

<b>12. Charging the brine circuit</b>	<b>58</b>
12.1 Mixing ratio	58
12.2 Charging the brine circuit	58
12.3 Check the brine concentration	58
<b>13. Commissioning</b>	<b>58</b>
13.1 Checks before commissioning	59
13.2 Manual test of connected components	59
13.3 Checking for unusual noises	60
13.4 Connecting to the internet	60
13.5 Locking commissioning mode	60
13.6 Heating curve adjustment during commissioning	60
13.7 Appliance handover	60
<b>14. Appliance shutdown</b>	<b>60</b>
<b>15. Troubleshooting</b>	<b>60</b>
15.1 BM card status display	60
15.2 Error message	61
15.3 Fault table	61
<b>16. Maintenance</b>	<b>61</b>
<b>17. Decommissioning</b>	<b>61</b>
<b>18. Specification</b>	<b>62</b>
18.1 Estimated current intensity	62
18.2 Connections	62
18.3 Dimensions and connections	63
18.4 Wiring diagram	64
18.5 Output diagrams	72
18.6 Energy consumption data	80
18.7 Data table	82
<b>19. Appendix</b>	<b>84</b>
19.1 Fault table	84
19.2 Commissioning checklist	86

## GUARANTEE

## ENVIRONMENT AND RECYCLING

## SPECIAL INFORMATION

- The appliance may be used by children over 8 years of age and persons with reduced physical, sensory or mental capabilities or a lack of experience and expertise, provided that they are supervised or they have been instructed on how to use the appliance safely and have understood the potential risks. Children must never play with the appliance. Children must never clean the appliance or perform user maintenance unless they are supervised.
- The connection to the power supply must be in the form of a permanent connection. Ensure the appliance can be separated from the power supply by an isolator that disconnects all poles with at least 3 mm contact separation.
- Maintain the minimum clearances to ensure trouble-free operation of the appliance and facilitate maintenance work.
- In dual mode operation, return water from the second heat generator may flow through the heat pump. Please note that the return water temperature may be a maximum of 65 °C.
- The appliance can be used for active and passive cooling. This however, is only possible in conjunction with a suitable hydraulic circuit.
- Only qualified contractors may perform maintenance work, such as electrical safety checks.
- We recommend regular inspection (to establish the current condition of the system), and maintenance by a qualified contractor if required (to return the system to its original condition).
- Following isolation from the mains supply, parts of the appliance may remain live. This is because the condensers on the inverter still have to discharge. When the condensers have discharged, the LEDs on the inverter stop flashing.
- Never interrupt the power supply, even outside the heating season. The system's active frost protection is not guaranteed if the power supply is interrupted.
- There is no need to shut the system down in summer. The programming unit has an automatic summer/winter changeover.

# OPERATION

## 1. General information

The chapters “Special information” and “Operation” are intended for both users and qualified contractors.



The chapter “Installation” is intended for qualified contractors.



### Note

Read these instructions carefully before using the appliance and retain them for future reference. Pass on the instructions to a new user if required.

### 1.1 Relevant documents

-  Operating instructions for the programming unit
-  Commissioning instructions for the programming unit
-  Operating and installation instructions for system components

### 1.2 Safety instructions

#### 1.2.1 Structure of safety instructions





#### KEYWORD Type of risk

Here, possible consequences are listed that may result from failure to observe the safety instructions.

► Steps to prevent the risk are listed.

#### 1.2.2 Symbols, type of risk

Symbol	Type of risk
	Injury
	Electrocution

#### 1.2.3 Keywords

KEYWORD	Meaning
DANGER	Failure to observe this information will result in serious injury or death.
WARNING	Failure to observe this information may result in serious injury or death.
CAUTION	Failure to observe this information may result in non-serious or minor injury.



### 1.3 Other symbols in this documentation



#### Note

General information is identified by the adjacent symbol.

► Read these texts carefully.

Symbol	Meaning
	Material losses (appliance damage, consequential losses and environmental pollution)
	Appliance disposal

► This symbol indicates that you have to do something. The action you need to take is described step by step.

### 1.4 Units of measurement



#### Note

All measurements are given in mm unless stated otherwise.

### 1.5 Standardised output data

Information on determining and interpreting the specified standardised output data

#### 1.5.1 Standard: EN 14511

The output data specifically mentioned in text, diagrams and technical datasheets has been calculated according to the test conditions of the standard shown in the heading of this section.

Generally, these standardised test conditions will not fully meet the conditions found at the installation site of the system user.

Depending on the chosen test method and the extent to which this method deviates from the conditions defined in the norm shown in the heading of this section, any deviations can have a considerable impact.

Additional factors that have an influence on the test values are the measuring equipment, the system configuration, the age of the system and the flow rates.

A confirmation of the specified output data can only be obtained if the test conducted for this purpose is also performed in accordance with the conditions defined in the norm shown in the heading of this section.

## 2. Safety

### 2.1 Intended use

The appliance is designed for:

- Heating rooms
- Cooling rooms
- Heating of DHW

Observe the operating limits listed in chapter "Specification".

The appliance is intended for domestic use. It can be used safely by untrained persons. The appliance can also be used in non-domestic environments, e.g. in small businesses, as long as it is used in the same way.

Any other use beyond that described shall be deemed inappropriate. Observation of these instructions and of instructions for any accessories used is also part of the correct use of this appliance.

### 2.2 Safety instructions

- Only recognised, qualified contractors may carry out the electrical work and installation of the heating circuit.
- Work on the refrigerant circuit must only be carried out by a recognised and qualified refrigeration engineer or by our customer service engineer.
- The qualified contractor is responsible for adherence to all applicable regulations during installation and commissioning.
- The appliance should only be operated once it is fully installed and all safety equipment has been fitted.
- Protect the appliance from dust and dirt during building work.



#### WARNING Injury

The appliance may be used by children over 8 years of age and persons with reduced physical, sensory or mental capabilities or a lack of experience and expertise, provided that they are supervised or they have been instructed on how to use the appliance safely and have understood the potential risks. Children must never play with the appliance. Children must never clean the appliance or perform user maintenance unless they are supervised.



#### WARNING Injury

► For safety reasons, only operate the appliance with the casing closed.



#### WARNING Injury

The system contains refrigerant. Refrigerant is heavier than air. If refrigerant escapes from the appliance, it sinks and displaces the air. There is risk of suffocation.  
► Install the appliance only in rooms with adequate ventilation.



#### WARNING Injury

In conjunction with naked flames, refrigerant forms a toxic irritant gas. The gas can already be smelt at concentrations well below the permissible limit values.  
► Leave the room until it has been adequately ventilated.

### 2.3 Test symbols

See type plate on the appliance.

## 3. Appliance description

The appliance is a heating heat pump suitable for operation as a brine/water heat pump. The heat pump extracts energy from the heat source medium at a low temperature level. This extracted energy is then transferred to the heating water at a higher level, augmented by the electric energy drawn by the compressor. Subject to the heat source temperature, heating water can be heated up to a flow temperature of 65 °C.

If a DHW cylinder is integrated in the system, the appliance can be used to heat DHW. To heat the DHW, the heating water that has been heated by the heat pump is directed through an indirect coil in the DHW cylinder, where it transfers its energy to the DHW.

An electric threaded immersion heater can be installed in the buffer and DHW cylinder for use as a booster heater (see chapter "Installation / Appliance description / Accessories / Additional accessories"). An external, second heat generator can also be integrated in the system as a booster heater.

The optional Internet Service Gateway ISG accessory allows the system to be monitored via the internet.

## 4. Operation

The heat pump is exclusively controlled via the programming unit. Observe the instructions for the programming unit.

## 5. Maintenance and care



#### Material losses

Only qualified contractors may perform maintenance work, such as electrical safety checks.

A damp cloth is sufficient for cleaning all plastic and sheet metal parts. Never use abrasive or corrosive cleaning agents.

We recommend regular inspection (to establish the current condition of the system), and maintenance by a qualified contractor if required (to return the system to its original condition).

## 6. Troubleshooting

Fault	Cause	Remedy
There is no hot water or the heating system remains cold.	The fuse/MCB has blown/responded.	Check the fuses/MCBs in your fuse box/distribution board.

### 6.1 Other problems

If you cannot remedy the fault, contact your qualified contractor. To facilitate and speed up your request, provide the number from the type plate. The type plate is located at the top left on the appliance cover.

# INSTALLATION

## 7. Safety

Only a qualified contractor should carry out installation, commissioning, maintenance and repair of the appliance.

### 7.1 General safety instructions

We guarantee trouble-free function and operational reliability only if original accessories and spare parts intended for the appliance are used.

### 7.2 Instructions, standards and regulations



#### Note

Observe all applicable national and regional regulations and instructions.

The tested appliance conforms to IEC 61000-3-12.

## 8. Appliance description

The heat exchanger on the heat source side (evaporator) extracts natural heat from the heat source. This extracted energy and the energy drawn by the compressor drive is transferred to the heating water by a heat exchanger on the heating water side (condenser). Subject to the heat load, the heating water is heated up to +65 °C.

If the heat demand of the heating system exceeds the heating output of the heat pump, the booster heater covers the residual heat demand.

If the hot gas function is used, the heat pump can be used to achieve DHW temperatures over 60 °C when heating without a booster heater. The compressed refrigerant transfers the energy absorbed by the compressor to the DHW in a hot gas heat exchanger. The refrigerant then flows into a second heat exchanger in which the energy is transferred to the heating water.

Outside the heating season, DHW heating can be supported by a booster heater.

The heat pump is not suitable for dry heating the screed.

### 8.1 Standard delivery

The following are delivered with the appliance:

- Outside sensor
- Immersion / contact sensor
- Split ferrite

### 8.2 Accessories

- Extension module EM WPE-I 33-87
- Hot gas set HG set WPE-I 33-87
- Remote control FE WPE-I 33-87
- Instantaneous water cylinder SBS 601-1501 W (SOL)
- Electric threaded immersion heater BGC 2/60
- Buffer cylinder (for cooling)

#### WPE-I 33 H 400 Premium | WPE-I 44 H 400 Premium

- Pressure hose SD 32-0.6 G
- Pressure hose SDB 40-0.8 G

#### WPE-I 59 H 400 Premium | WPE-I 87 H 400 Premium

- Pressure hose SD 40-0.8 G
- Pressure hose SDB 50-0.8 G

## 9. Preparation



#### Note

The appliance is designed for indoor installation, except in damp areas.

### 9.1 Sound emissions



#### Note

For details regarding the sound power level, see the chapter "Specification / Data table".

- Never site the appliance on joist floors.
- ▶ Ensure that the entire appliance frame is in full contact with the substrate. Uneven substrates can increase sound emissions.
- ▶ Never install the appliance directly below or next to a living room or bedroom.
- ▶ Avoid installation on large, echoing floor areas, e.g. tiled floors.
- ▶ Avoid installation between reflective building walls. Reflecting building walls can increase the noise level.
- ▶ Never install the appliance in the corner of the installation room.
- ▶ Implement pipe outlets through walls and ceilings with anti-vibration insulation.
- ▶ Use flexible supply lines.
- ▶ Secure the supply lines with structure-borne noise attenuation on noise-sensitive walls.
- ▶ Ensure that the appliance feet are aligned.

# INSTALLATION

## Preparation

### 9.2 Minimum clearances

WPE-I 33 H 400 Premium | WPE-I 44 H 400 Premium

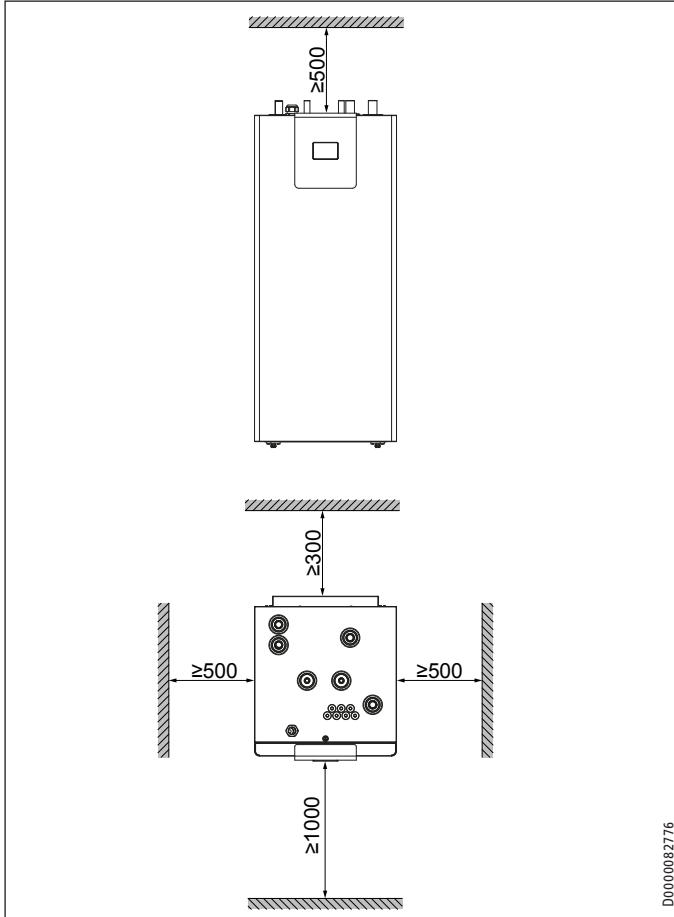

- Maintain the minimum clearances to ensure trouble-free operation of the appliance and facilitate maintenance work.

WPE-I 59 H 400 Premium | WPE-I 87 H 400 Premium

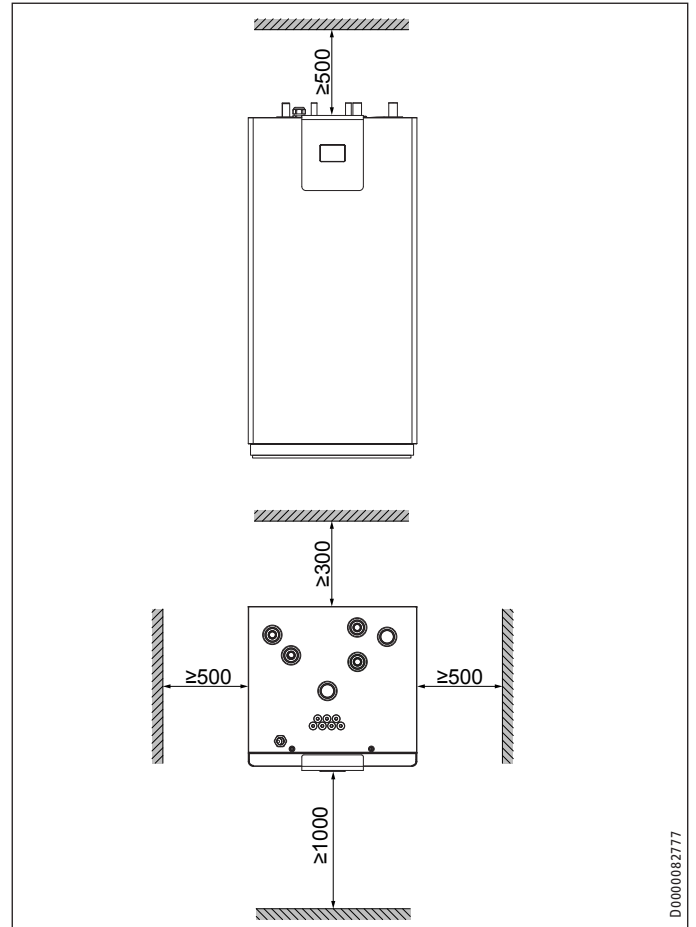

- Maintain the minimum clearances to ensure trouble-free operation of the appliance and facilitate maintenance work.

### 9.3 Preparation of the installation site

- Observe chapter “Sound emissions”.

The room where the appliance is installed must meet the following conditions:

- No risk from frost.
- The room must not be subject to a risk of explosions arising from dust, gases or vapours.
- When installing the appliance in a boiler room together with other heating equipment, ensure that the operation of other heating equipment will not be impaired.
- Load bearing floor (for the weight of the appliance, see chapter “Specification / Data table”).
- Install the appliance, ideally on an external wall.
- Ensure that the substrate is level, even, solid and permanent.
- Install the appliance on a concrete floor with a thickness of at least 100 mm or on another base with corresponding characteristics.
- For installation on floating screeds, make provisions for quiet heat pump operation.
- Isolate the installation surface around the heat pump by means of a recess. After completing the installation, seal the recess with a waterproof, sound insulating material, such as silicone.

# INSTALLATION

## Preparation

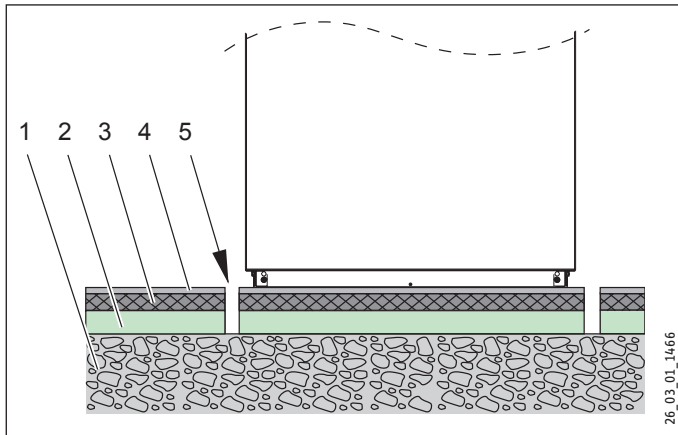

- 1 Concrete base
- 2 Impact sound insulation
- 3 Floating screed
- 4 Floor covering
- 5 Recess

### 9.4 Wall outlet

#### 9.4.1 General

- ▶ Always ensure there is enough space for the other supply lines in the wall outlets (see chapter “Specification / Dimensions and connections”).
- ▶ Route the brine lines through separate wall outlets.
- ▶ Provide thermal insulation on the brine lines in accordance with applicable regulations.

#### 9.4.2 Wall outlets above ground

- ▶ Establish wall outlets in the building wall with a slight fall to the outside (minimum inclination: 1 cm every 30 cm).
- ▶ Insert the wall outlets with a slight fall.
- ▶ Seal the space between the wall and wall outlet with mortar.
- ▶ Route the brine lines through the wall outlets.
- ▶ Seal the space between the brine line and wall outlet with a suitable sealant (e.g. well foam). Ensure the brine lines are centred in the wall outlets.

#### 9.4.3 Wall outlets below ground



##### Material losses

- ▶ Use waterproof wall outlets below the highest groundwater level.

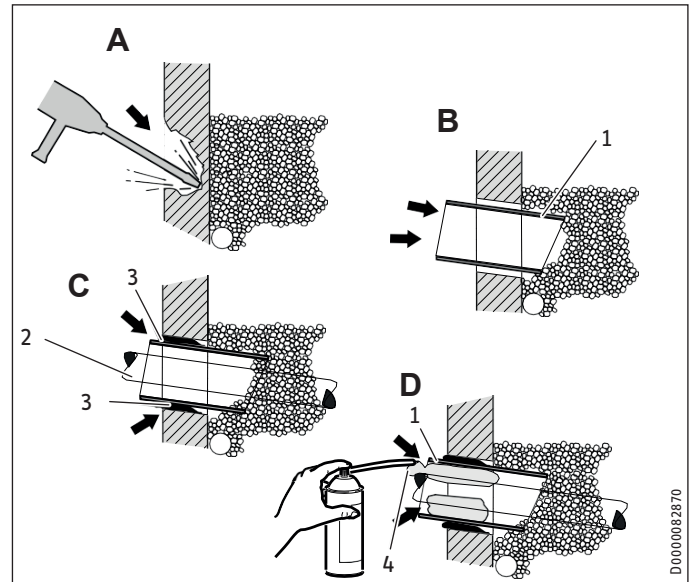

- 1 Wall outlet
- 2 Brine line
- 3 Mortar
- 4 Sealant

- ▶ Establish wall outlets in the building wall with a slight fall to the outside (minimum inclination: 1 cm every 30 cm).
- ▶ Insert the wall outlets with a slight fall.
- ▶ Cut off the wall outlet from the top downwards at an angle to the building wall.
- ▶ Seal the space between the wall and wall outlet with mortar.
- ▶ Route the brine lines through the wall outlets.
- ▶ Seal the space between the brine line and wall outlet with a suitable sealant (e.g. well foam). Ensure the brine lines are centred in the wall outlets.



# INSTALLATION

## Installation

### 9.5 Preparing the electrical installation



#### WARNING Electrocutation

Carry out all electrical connection and installation work in accordance with national and regional regulations.



#### WARNING Electrocutation

The connection to the power supply must be in the form of a permanent connection. Ensure the appliance can be separated from the power supply by an isolator that disconnects all poles with at least 3 mm contact separation. This requirement can be met by using contactors, circuit breakers, fuses/MCBs, etc.



#### Note

The specified voltage must match the mains voltage. Observe the type plate.

- ▶ Use cables with the relevant cross-sections. Observe the applicable national and regional regulations.

Electrical data is provided in chapter “Specification / Data table”.



#### Note

The appliance includes an inverter for the variable speed compressor. In the event of an error, inverters can cause DC residual currents. If RCDs are provided, they must be type B AC/DC-sensitive.

A DC residual current can block type A RCDs.

- ▶ Ensure that the appliance power supply is disconnected from the distribution board.

## 10. Installation

### 10.1 Transport

- ▶ Transport the appliance in its packaging in an upright position to protect it against damage.
- ▶ Protect the appliance against heavy impact during transport.
- If the appliance needs to be tilted during transport, this must only be for a short time and it must only be tilted on one of its longitudinal sides.  
The longer the appliance is tilted, the greater the distribution of refrigerant oil inside the system.
- Storage and transport at temperatures below - 20 °C and above + 50 °C are not permissible.

### 10.2 Siting

- ▶ Remove the packaging material.
- ▶ Lift the appliance off the pallet with a forklift truck.
- ▶ Position the appliance on the prepared substrate.
- ▶ Maintain the minimum clearances.
- ▶ Level the appliance horizontally by adjusting the feet.

### 10.3 Removing the casing parts

#### WPE-I 33 H 400 Premium | WPE-I 44 H 400 Premium

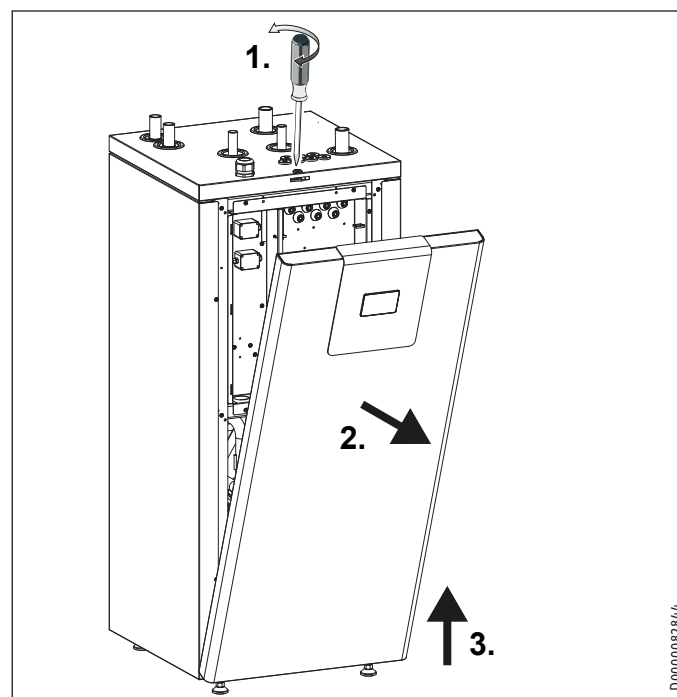

- ▶ Undo the closure on the top cover.
- ▶ Pull the top of the front panel forwards.
- ▶ Remove the front panel by lifting it upwards.

#### WPE-I 59 H 400 Premium | WPE-I 87 H 400 Premium

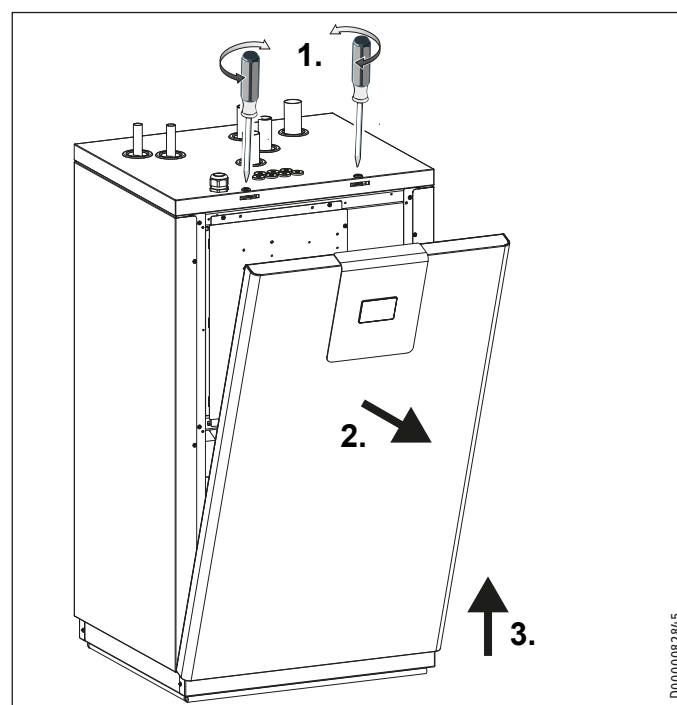

- ▶ Undo the two closures on the top cover.
- ▶ Pull the top of the front panel forwards.
- ▶ Remove the front panel by lifting it upwards.

# INSTALLATION

## Installation

### 10.4 Installing the heat source system



#### Note

Engineer the heat source system for the brine/water heat pump according to the technical guides.

Permitted brine:

		Part number
MEG 10	Heat transfer medium as concentrate on an ethylene glycol base	231109
MEG 30	Heat transfer medium as concentrate on an ethylene glycol base	161696

#### 10.4.1 Connection

- ▶ Thoroughly flush the pipework with brine before connecting the heat pump to the heat source circuit. Foreign bodies, such as rust, sand and sealant, can impair the operational reliability of the heat pump.
- ▶ Insert a filter (maximum mesh size 0.7 mm) in the heat source flow.
- ▶ Install the heat source flow and heat source return with all the necessary components.
- ▶ Insulate the heat source flow and heat source return against vapour diffusion to prevent the formation of condensate.
- ▶ Size the diaphragm expansion vessel according to the manufacturer's instructions. The maximum operating pressure of the heat source is 6 bar.
- ▶ Check for tightness.

### 10.5 Flow and return connection

#### 10.5.1 Heating water quality

Carry out a fill water analysis before filling the system. This may, for example, be requested from the relevant water supply utility.



#### Material losses

To avoid damage as a result of scaling, it may be necessary to soften or desalinate the fill water. Always observe the fill water limits specified in the "Specification / Data table" chapter.

- ▶ Recheck these limits 8-12 weeks after commissioning and as part of the annual system maintenance.



#### Note

With a conductivity > 1000 µS/cm, desalination treatment is recommended in order to avoid corrosion.



#### Note

Suitable appliances for water softening and desalinating, as well as for charging and flushing heating systems, can be obtained via trade suppliers.



#### Note

If you treat the fill water with inhibitors or additives, the same limits apply as for desalination.

- ▶ Avoid chemical and oil contamination.

### 10.5.2 Heating water connection



#### Material losses

Ensure the supply lines are not under tension, in order to avoid leaks.

The heating system to which the heat pump is connected must be installed by a qualified contractor in accordance with the water installation diagrams that are part of the technical guides.

- ▶ Thoroughly flush the pipework before connecting the heat pump. Foreign bodies, such as rust, sand and sealant, can impair the operational reliability of the heat pump.
- ▶ Construct the heating flow and return from a heat-resistant and corrosion-resistant material (e.g. copper).
- ▶ Install a dirt trap (maximum mesh size 0.7 mm) in the heating return in the immediate vicinity of the appliance.
- ▶ Connect the heating system to the "heating flow" and "heating return" connections. Check for tightness.
- ▶ Ensure that the heating flow and return are connected correctly.
- ▶ Install air vent valves at the required positions.
- ▶ Install the heating circuit pump in the heating flow.
- ▶ Install a fill connector with a non-return valve.
- ▶ When sizing the heating circuit, observe the maximum available external pressure differential (see chapter "Specification / Data table").
- ▶ Provide thermal insulation in accordance with applicable regulations.

#### 10.5.3 Safety valve

- ▶ In heating systems with a sealed unvented diaphragm expansion vessel, install a pressure gauge and a safety valve (min. 20 DN) with a maximum opening pressure of 6 bar.
- ▶ Ensure the connection pipe of the diaphragm expansion vessel has a steady fall to the safety valve.
- ▶ Install the safety valve drain with a constant fall to the discharge outlet. When installing the drain, never kink the drain hose.
- ▶ Ensure that the safety valve drain is open to the outside and free from the risk of frost.
- ▶ Size the discharge outlet so that water can drain off unimpeded when the safety valve is fully opened.

### 10.6 Oxygen diffusion



#### Material losses

Do not use open vented heating systems. Use oxygen diffusion-proof pipes in underfloor heating systems with plastic pipework.

In underfloor heating systems with plastic pipes that are permeable to oxygen and in open vented heating systems, oxygen diffusion may lead to corrosion on the steel components of the heating system (e.g. on the indirect coil of the DHW cylinder, on buffer cylinders, steel radiators or steel pipes).

- ▶ With heating systems that are permeable to oxygen, separate the heating system between the heating circuit and the buffer cylinder.

# INSTALLATION

## Installation



### Material losses

The products of corrosion (e.g. rusty sludge) can settle in the heating system components, which may result in a lower output or fault shutdowns due to reduced cross-sections.

## 10.7 Filling the heating system



### Material losses

Never switch on the power before filling the system.

### 10.7.1 Checks before filling

- Have the pipe connections been carried out according to the water installation plans contained in the technical guides?
- Has the dirt trap been installed in the heating return?
- Has a diaphragm expansion vessel been installed?
- In heating systems with a sealed unvented diaphragm expansion vessel, have a safety valve and a pressure gauge been installed?
- Has a fill connector with a non-return valve been installed?

### 10.7.2 Filling the heating system



### Material losses

The pressure in the heating system must not exceed 6 bar.

- ▶ Vent the heating system carefully.

## WPE-I 33 H 400 Premium | WPE-I 44 H 400 Premium

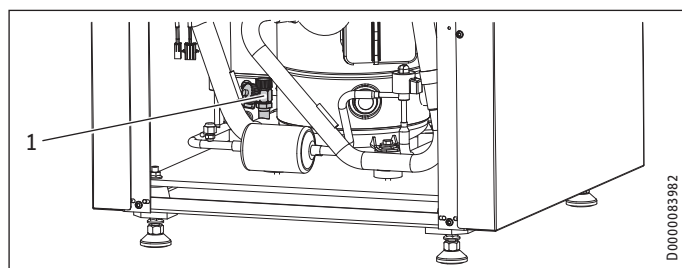

1 Drain

- ▶ Fill the heating system via the drain.
- ▶ Fully open all radiator valves.
- ▶ Bleed all the radiators.
- ▶ Fill the heating system via the drain.
- ▶ Repeat this process until there is no more air left in the heating system.
- ▶ Check the heating system for leaks.

## WPE-I 59 H 400 Premium | WPE-I 87 H 400 Premium

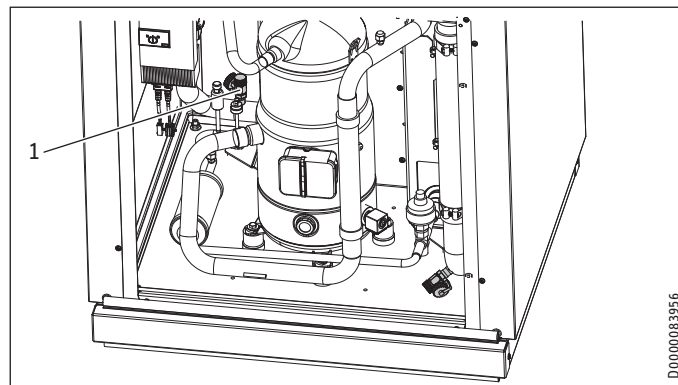

1 Drain

- ▶ Fill the heating system via the drain.
- ▶ Fully open all radiator valves.
- ▶ Bleed all the radiators.
- ▶ Fill the heating system via the drain.
- ▶ Repeat this process until there is no more air left in the heating system.
- ▶ Check the heating system for leaks.

## 10.8 DHW heating

For DHW heating, a DHW cylinder with an internal indirect coil is required (see chapter "Installation / Appliance description / Accessories").

- ▶ Thoroughly flush the pipework before connecting the heat pump. Foreign bodies, such as rust, sand and sealant, can impair the operational reliability of the heat pump.

### 10.8.1 DHW heating without hot gas technology

- ▶ Connect the heat pump DHW flow and heat pump DHW return from the DHW cylinder via a diverter valve to the heating flow and heating return.
- ▶ Observe the hydraulic diagrams in the technical guides.

### 10.8.2 DHW heating with hot gas technology

- ▶ Connect the heat pump DHW flow and heat pump DHW return from the DHW cylinder to the hot gas DHW flow optional and hot gas DHW return optional.
- ▶ Observe the hydraulic diagrams in the technical guides.

## 10.9 Operation with buffer cylinder

- ▶ Install the supplied flow sensor on the buffer outlet.
- ▶ Connect the flow sensor to the control panel.

### 11. Electrical connection

#### 11.1 General



##### WARNING Electrocutation

▶ Before working on the appliance, isolate it from the power supply at the control panel.  
Following isolation from the mains supply, parts of the appliance may remain live. This is because the condensers on the inverter still have to discharge. When the condensers have discharged, the LEDs on the inverter stop flashing.



##### WARNING Electrocutation

Carry out all electrical connection and installation work in accordance with national and regional regulations.



##### WARNING Electrocutation

▶ Connect the power cable only to the intended terminal.  
▶ Do not use any other terminals.



##### WARNING Electrocutation

The inverter has a high fault current and must be earthed.  
▶ Ensure there is a good connection between the earth cable and the earthing contact. The cross-section of the earth conductor must be designed according to the maximum operating current (see chapter "Specification / Data table").



##### Material losses

The power cables must not be connected via a regularly switching contactor. If an externally controlled shutdown is necessary (e.g. by the power supply utility), this must be performed via the "PSU/Smart Grid 1" contact. When the contact is enabled, the heat pump will switch off within a short period in a controlled manner.



##### Note

The heating system needs to be filled before making the electrical connection (see the "Heating water connection" chapter).

Connection work must only be carried out by a qualified contractor and in accordance with these instructions.

You must have permission to connect the appliance from the relevant power supply utility (PSU).

- ▶ Follow the instructions in the chapter "Preparation / Preparing the electrical installation".
- ▶ Use appropriate electrical cables in accordance with local regulations for the connections.
- ▶ Only connect the appliance to a supply system with a short-circuit capacity greater than the values listed in the table.

Heat pump	Short-circuit capacity [MVA]
WPE-I 33 H 400 Premium	2.1
WPE-I 44 H 400 Premium	2.1
WPE-I 59 H 400 Premium	2.4
WPE-I 87 H 400 Premium	3.2

#### 11.2 Checks before electrical connection

- ▶ Does the appliance have adequate fuse protection?
- ▶ Has the outside temperature sensor been positioned correctly? Observe chapter "Sensor installation".

#### 11.3 Access to the terminal area

The terminals are located inside the appliance control panel, behind the front fascia.

- ▶ Remove the front panel of the appliance (see chapter "Installation / Removing the casing parts").
- ▶ Remove the three screws on the cover panel.
- ▶ Pivot the cover panel to the side.

#### 11.4 Terminal area

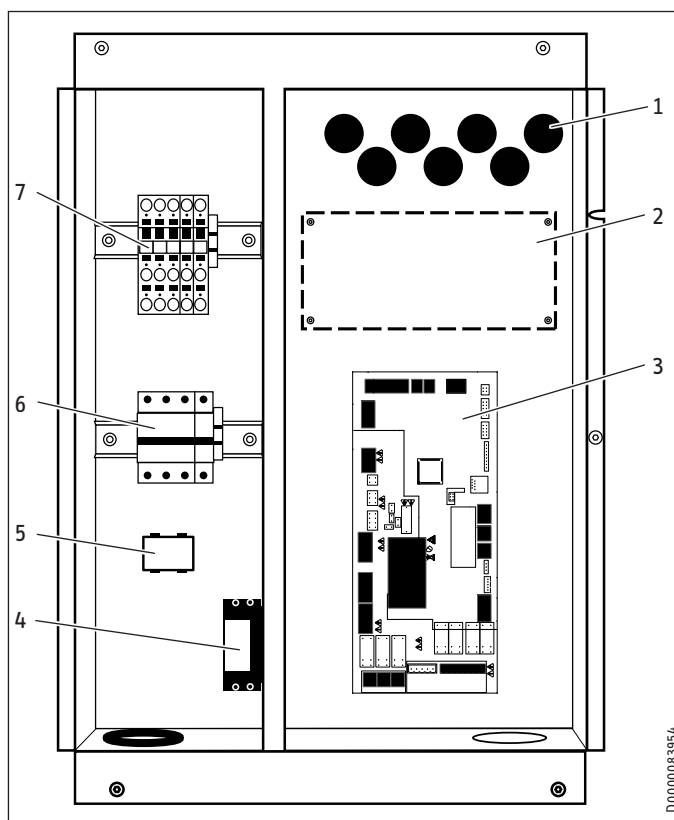

- 1 Cable grommet
- 2 Space for extension module EM3 (optional)
- 3 BM card (internal heat pump control unit)
- 4 Transformer
- 5 EMV filter
- 6 Fuse protection
- 7 Terminal X1

#### 11.5 Dynamic allocation

The BM card allows you some configurations. You can assign some connections on the BM card differently. The connections that are changeable can be recognised by the little boxes in the wiring diagram. Please note that the connections can only be used for the specified optional functions.

- ▶ Connect the corresponding component to the required connection.

- ▶ Mark any changes made on the wiring diagram in the appliance.
- ▶ Deactivate the factory-set function on the programming unit.
- ▶ Activate the new function on the programming unit.

### 11.6 Electrical connection



#### Note

In order to prevent failures in the electromagnetic field, attach the supplied split ferrite outside the connection area on the bus cable.



#### Note

If the power cables do not fit through the cable entries, use the supplied cable entries which can be cut to size.

#### 11.6.1 Routing power cables

- ▶ Route the power cables from above through the cable entries and into the appliance.

#### WPE-I 33 H 400 Premium | WPE-I 44 H 400 Premium

- ▶ Remove the cable entries in the control panel.
- ▶ Route the power cables through the apertures in the control panel.
- ▶ Feed the cable entries over the power cables.
- ▶ Push the cable entries securely back into the apertures.

#### WPE-I 59 H 400 Premium | WPE-I 87 H 400 Premium

- ▶ Route the power cables through the cable entries in the control panel.

#### 11.6.2 Power supply

X1 Heat pump  
L1, L2, L3, N, PE

- ▶ Connect the power cable to the terminal.

#### 11.6.3 Additional components



#### Note

▶ If you want to install a mixer, use a mixer with 24 V control voltage.

- ▶ Connect the power cables for the other components according to the wiring diagrams (see chapter “Specification / Wiring diagram” and “Appendix”).

### 11.7 Sensor installation

#### Outside temperature sensor

The temperature sensors have a significant influence on the function of your heating system. Therefore ensure sensors are correctly seated and well insulated.

When the sensor cable is laid in a pipe, the pipe must be sealed to prevent escaping air.

Install the outside temperature sensor on a north or north-eastern wall. Minimum clearances: 2.5 m above the ground, and 1 m to

the side of windows and doors. In high buildings, install the outside temperature sensor between the second and third floor. The outside temperature sensor should be freely exposed to the elements but not placed in direct sunlight. Never mount the outside temperature sensor above windows, doors or air ducts. Do not install the outside temperature sensor on reflective metal panels.

#### Immersion / contact sensor

This sensor is required when using a mixer circuit.

#### Sensor resistance values

Temperature in °C	Pt1000 sensor Resistance in Ω
-30	882
-20	922
-10	961
0	1000
10	1039
20	1078
25	1097
30	1117
40	1155
50	1194
60	1232
70	1271
80	1309
90	1347
100	1385
110	1423
120	1461

### 11.8 High limit safety cut-out for STB-FB area heating system



#### Material losses

In order to prevent excessively high flow temperatures in the area heating system causing damage in the event of a fault, install a high limit safety cut-out to limit the system temperature.

### 11.9 Internet Service Gateway ISG

The Internet Service Gateway ISG enables you to operate the heat pump within your local home network and via the internet when you are away. The ISG is not supplied with power by the heat pump.

- ▶ Observe the ISG operating instructions.

### 11.10 Termination at both ends of the accessories and building management system communication network

Termination of the communication network is required if a Modbus connection is used. Through the use of jumpers, termination ensures that the receiver gets the maximum signal strength through adjustment of the wiring impedance.

The jumpers on the BM card in the appliance are factory-fitted.

- ▶ Remove the relevant jumper if the appliance is no longer installed at one end of the communication network.

## Charging the brine circuit

### 12. Charging the brine circuit



#### Note

► Observe the regional and national regulations before filling with heat transfer medium.

Calculate the volume of the heat source circuit. The brine volume of the heat pump under operating conditions can be found in the data table (see chapter “Specification”).

The overall volume is equal to the required amount of brine made by mixing undiluted ethylene glycol and water. The chloride content of the water must not exceed 300 ppm.

#### 12.1 Mixing ratio

The brine concentration varies depending on whether a geothermal collector or a geothermal probe is used as the heat source.

For the mixing ratio see the table below.

	Ethylene glycol	Water
Geothermal probe	25 %	75 %
Geothermal collector	33 %	67 %

#### 12.2 Charging the brine circuit

WPE-I 33 H 400 Premium | WPE-I 44 H 400 Premium

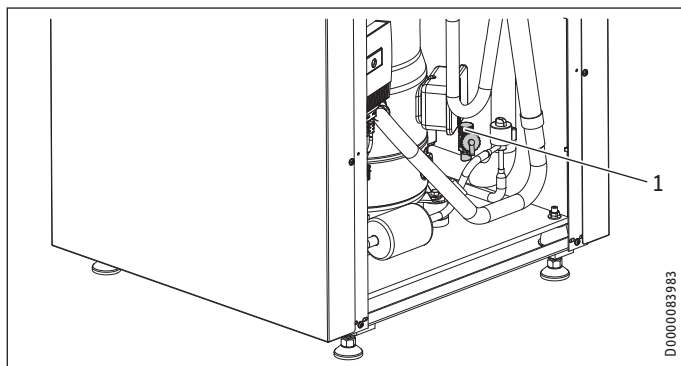

1 Drain

► Fill the brine circuit via the drain.

After filling the system with brine and prior to commissioning, vent the brine circuit until there is no more air left in it.

WPE-I 59 H 400 Premium | WPE-I 87 H 400 Premium

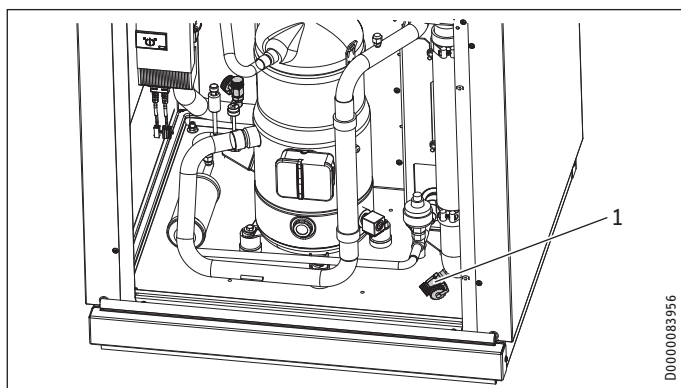

1 Drain

► Fill the brine circuit via the drain.

After filling the system with brine and prior to commissioning, vent the brine circuit until there is no more air left in it.

#### 12.3 Check the brine concentration

► Determine the density of the ethylene glycol/water mixture, e.g. with a hydrometer.

Using the actual density and temperature, you can check the actual concentration in the diagram.



#### Note

The quoted performance data relates to ethylene glycol (see “Specification”).

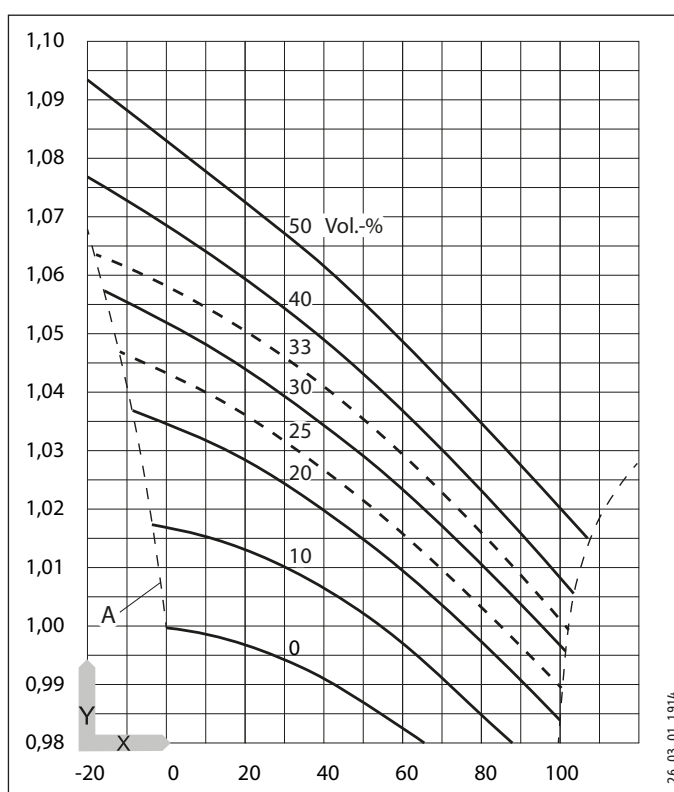

X Temperature [°C]

Y Density [g/cm<sup>3</sup>]

A Frost protection [°C]

### 13. Commissioning



#### Material losses

Do not operate the appliance until the heating system, the heat source system and the hot water boiler have been filled and vented to the correct pressure.



#### Note

The sensor on the heating flow and the outside sensor must be connected so that the appliance can calculate the required heating output.

# INSTALLATION

## Commissioning



### Note

Class A messages prevent the appliance from starting.  
▶ Identify the errors in displayed messages.

A qualified contractor must commission the appliance, make all the settings in the programming unit, and instruct the user.

Carry out commissioning in accordance with these operating and installation instructions and the programming unit instructions. Our customer support can assist with commissioning, which is a chargeable service. Observe the commissioning checklist in the appendix of these operating and installation instructions.

Where this appliance is intended for commercial use, the regulations of the relevant Health & Safety at Work Act may apply during commissioning. For further details, check your local authorising body.

### 13.1 Checks before commissioning

Before commissioning, check the points detailed below.

#### 13.1.1 Heating system

- Have you filled the heating system to the correct pressure?
- Have you vented the heating system?



### Material losses

In the case of area heating systems, observe the maximum system temperature.

#### 13.1.2 Heat source



### Material losses

Never use the heat pump to dry the screed by means of the underfloor heating system.

- Have you filled the brine circuit to the correct pressure?
- Have you vented the brine circuit?

#### 13.1.3 Temperature sensor

- Have you correctly positioned and connected the outside sensor and the return temperature sensor (in connection with a buffer cylinder)?

#### 13.1.4 Power supply

- Have you correctly connected the power supply?

### 13.2 Manual test of connected components



### Note

A hand is displayed when the manual test is activated. All settings carried out now do not lead to any parameter changes at the heat pump.

- ▶ Call up the “Manual test” menu in the programming unit (see chapter “Controller menu / Settings / Manual test” in the programming unit commissioning instructions).
- ▶ Activate the manual test.
- ▶ Observe the following information.



### Note

Deactivate the menu item “Manual test” after carrying out the different tests.

#### 13.2.1 Mandatory tests

##### Circulation pump

- ▶ In the “Manual test” menu, select the circulation pump test.
- ▶ Start the circulation pump via the menu.
- ▶ Check whether the circulation pump is running.
  - Listen.
  - Place your hand on the pump.
  - Listen for air noises.
- ▶ Vent the heating system if necessary (see chapter “Installation / Filling the heating system”).
- ▶ Stop the circulation pump via the menu.

##### Brine pump



### Material losses

The pressure in the heat source system must not exceed 6 bar.

- ▶ In the “Manual test” menu, select the brine pump test.
- ▶ Start the brine pump via the menu.
- ▶ Check whether the brine pump is running.
  - Listen.
  - Place your hand on the pump.
  - Listen for air noises.
- Check if the fluid level in the diaphragm expansion vessel remains stable. If the fluid level does not remain stable, there is air in the brine circuit.
- ▶ Vent the brine circuit if required (see chapter “Charging the brine circuit”).
- ▶ Stop the brine pump via the menu.

##### Heating circuit pump

- ▶ In the “Manual test” menu, select the heating circuit pump test.
- ▶ Start the heating circuit pump via the menu.
- ▶ Check whether the heating circuit pump is running.
  - Listen.
  - Place your hand on the pump.
  - Listen for air noises.
- ▶ Vent the heating system if necessary (see chapter “Installation / Filling the heating system”).
- ▶ Stop the heating circuit pump via the menu.

## Appliance shutdown

### Compressor

- ▶ In the “Manual test” menu, select the compressor test.
- ▶ Select the compressor stage to be tested.
- ▶ Check that no unusual noises can be heard.
- ▶ Check if the hot gas line gets hot.
- ▶ Check the other compressor stages.
- ▶ Stop the compressor via the menu.

### 13.2.2 Optional tests

The additional tests displayed in the “Manual test” menu are optional.

### 13.3 Checking for unusual noises

Under adverse circumstances, supply lines and the way they are routed can cause noise and vibrations, which are increased at certain compressor and pump speeds.

- ▶ Test the operation of the appliance in heating and DHW mode across the entire speed range of the compressor and pumps.
- ▶ Make sure there are no unusual noises near the appliance and in other parts of the building.
- ▶ If required, install anti-vibration mounts and sound-absorbing pipe clamps near the appliance.
- ▶ If the unusual noises continue occurring, you can block or adjust the problematic speeds of the compressor and the pumps in the controller.

### 13.4 Connecting to the internet

The connection required to connect to the internet can be found behind the front panel below the controller unit.

- ▶ Remove the front panel (see chapter “Installation / Removing the casing parts”).
- ▶ Connect a router to the terminal.
- ▶ Observe the commissioning instructions for the programming unit and the operating and installation instructions for the Internet Service Gateway (ISG).

### 13.5 Locking commissioning mode

After commissioning, leave the programming unit in safe mode.

- ▶ Press the open lock on the screen. Confirm the selection. A closed lock appears on the left of the menu window.

### 13.6 Heating curve adjustment during commissioning

The efficiency of a heat pump decreases as the flow temperature rises. Therefore adjust the heating curve with care. A heating curve that is set too high leads to the zone or thermostatic valves closing and the minimum flow rate required for the heating circuit may not be achieved.

The following steps will help you to adjust the heating curve correctly:

- ▶ Fully open thermostatic or zone valves in a lead room (e.g. living room or bathroom).  
We do not recommend installing thermostatic or zone valves in the lead room. Control the temperature for these rooms via a remote control.

- ▶ At different outside temperatures (e.g. -10 °C and +10 °C), adjust the heating curve so the required temperature is achieved in the lead room.

### 13.7 Appliance handover

Explain the appliance function to users and familiarise them with how it works.



#### Note

Hand over these operating and installation instructions to the user for safe-keeping. All information in these instructions must be closely observed. The instructions provide information on safety, operation, installation and maintenance of the appliance.

## 14. Appliance shutdown

If the system is to be taken out of use, set the programming unit to standby. This retains the safety functions designed to protect the system (e.g. frost protection).

There is no need to shut the system down in summer. The programming unit has an automatic summer/winter changeover.



#### Material losses

Never interrupt the power supply, even outside the heating season. The system's active frost protection is not guaranteed if the power supply is interrupted.



#### Material losses

Observe the temperature application limits and the minimum circulation volume on the heat consumer side (see chapter “Specification / Data table”).



#### Material losses

If the heat pump is completely switched OFF and there is a risk of frost, drain the system on the water side.

## 15. Troubleshooting



#### WARNING Electrocutation

- ▶ Isolate the appliance from the power supply when carrying out any work.

Following isolation from the mains supply, parts of the appliance may remain live. This is because the condensers on the inverter still have to discharge. When the condensers have discharged, the LEDs on the inverter stop flashing.

### 15.1 BM card status display

LEDs are arranged on the BM card (internal heat pump control unit) which display the current control status.



The two individual LEDs show the communication status.

	LED	Meaning
RX (receiver)	illuminates	The control is processing a message or responding to a message that was sent to the inverter.
TX (transmitter)	illuminates	The control is responding to a message.

The four LEDs show the control status.

LED	Meaning			
1	2	3	4	
x				Standard condition
x	○	○	○	Safety stop The compressor is blocked.
x	x	x	x	Update mode The heat pump profile cannot be configured.
-	-	-	-	Frost protection Not assigned

x Flashing  
○ illuminates

### 15.2 Error message

If the appliance registers an error, this is displayed clearly on the programming unit.

#### 15.2.1 The heat pump is not running

The wrong heat pump is set on the programming unit.

- ▶ Check the set model in the “Process data / Version information” menu.
- ▶ Have the service engineer set the correct heat pump.

The heat pump is in standby mode [⏻].

- ▶ Change the system setting to standard operation.

The blocking time for the power supply utility (PSU) is applied.

- ▶ Wait for the blocking time to elapse. The heat pump will automatically start up again.

There is no heat demand.

- ▶ Under the menu item “Process data / Operating data / Calculated demand (heating)”, check if there is a heating demand.

There may be an incorrect fuse protection rating.

- ▶ See chapter “Specification / Data table”.



#### Note

The heat pump can only be restarted after the error has been removed and deleted from the message list.

## 16. Maintenance



### WARNING Electrocutation

▶ Isolate the appliance from the power supply when carrying out any work.  
Following isolation from the mains supply, parts of the appliance may remain live. This is because the condensers on the inverter still have to discharge. When the condensers have discharged, the LEDs on the inverter stop flashing.

We recommend a regular inspection (to establish the current condition of the system), and maintenance if required (to return the system to its original condition).

- ▶ Check the pressure in the brine circuit regularly. Never exceed the maximum pressure of 6 bar.
- ▶ Check the pressure in the heating circuit at least twice a year. Never exceed the maximum pressure of 6 bar.
- ▶ Check the safety valve for correct function.
- ▶ Check the DHW lines for leaks between the heat pump and the draw-off points.
- ▶ Check the brine circuit for leaks.
- ▶ Check and clean the filters in the heating circuit and brine circuit twice in the first year since commissioning. The maintenance interval can be extended in subsequent years.

### WPE-I 59 H 400 Premium | WPE-I 87 H 400 Premium

- ▶ Ensure that the heat pump refrigerant circuit is tested once a year for leaks, in accordance with EC DIRECTIVE 517/2014.

## 17. Decommissioning



### Material losses

If the heat pump is completely switched OFF and there is a risk of frost, drain the system on the water side.

### 15.3 Fault table

See the appendix for an overview of possible errors.

## 18. Specification

### 18.1 Estimated current intensity

- ▶ Refer to the tables to find the estimated current intensity of the appliance at a certain radiator flow and heat source temperature.

#### 18.1.1 WPE-I 33 H 400 Premium

Radiator flow [°C]	Heat source temperature [°C]							
	-10	-5	0	5	10	15	20	
65	*	*	*	24.9	25.2	25.2	24.8	
60	*	*	22.8	23.2	23.4	23.3	23.0	
55	*	20.8	21.3	21.6	21.7	21.7	21.4	
50	19.0	19.5	19.9	20.1	20.3	20.3	20.1	
45	17.9	18.3	18.6	18.8	19.0	19.0	18.9	
40	16.9	17.1	17.4	17.6	17.8	18.0	18.0	
35	15.8	16.0	16.3	16.6	16.8	17.1	17.3	
30	14.8	15.0	15.2	15.6	15.9	16.3	16.8	

\* No details

#### 18.1.2 WPE-I 44 H 400 Premium

Radiator flow [°C]	Heat source temperature [°C]							
	-10	-5	0	5	10	15	20	
65	*	*	*	28.6	29.0	29.0	*	
60	*	*	28.3	28.9	29.3	29.2	29.0	
55	*	25.7	26.4	26.9	27.2	27.2	27.0	
50	23.5	24.0	24.6	25.0	25.3	25.3	25.1	
45	22.0	22.4	22.8	23.2	23.5	23.6	23.5	
40	20.6	20.9	21.2	21.6	21.9	22.1	22.2	
35	19.3	19.4	19.7	20.1	20.5	20.9	21.1	
30	18.0	18.1	18.4	18.8	19.4	19.9	20.2	

\* No details

#### 18.1.3 WPE-I 59 H 400 Premium

Radiator flow [°C]	Heat source temperature [°C]							
	-10	-5	0	5	10	15	20	
65	*	*	*	38.9	39.4	39.4	*	
60	*	*	38.5	39.4	39.8	39.8	39.5	
55	*	35.1	36.0	36.7	37.1	37.1	36.8	
50	32.2	32.9	33.6	34.2	34.5	34.6	34.4	
45	30.3	30.7	31.3	31.8	32.2	32.3	32.2	
40	28.4	28.7	29.2	29.7	30.1	30.4	30.4	
35	26.6	26.8	27.2	27.7	28.3	28.8	29.0	
30	25.0	25.0	25.4	26.0	26.8	27.5	27.9	

\* No details

#### 18.1.4 WPE-I 87 H 400 Premium

Radiator flow [°C]	Heat source temperature [°C]							
	-10	-5	0	5	10	15	20	
65	*	*	*	51.4	51.8	52.3	*	
60	*	*	52.5	53.1	53.5	54.0	54.2	
55	*	47.6	48.2	48.7	49.1	49.5	49.2	
50	42.9	43.7	44.2	44.7	45.0	45.4	45.7	
45	39.5	40.2	40.7	41.2	41.6	42.0	42.3	
40	36.6	37.3	37.9	38.3	38.8	39.3	39.7	
35	34.4	35.2	35.8	36.3	36.9	37.6	38.1	
30	33.1	33.9	34.6	35.3	36.0	36.9	37.5	

\* No details

## 18.2 Connections

Pipeline	Pipe diameter [mm]			
	WPE-I 33 H 400 Premium	WPE-I 44 H 400 Premium	WPE-I 59 H 400 Premium	WPE-I 87 H 400 Premium
Brine line	42	42	54	54
Heating system	35	35	42	42
Hot gas heat exchanger	28	28	28	28

# INSTALLATION Specification

## 18.3 Dimensions and connections

### WPE-I 33 H 400 Premium | WPE-I 44 H 400 Premium

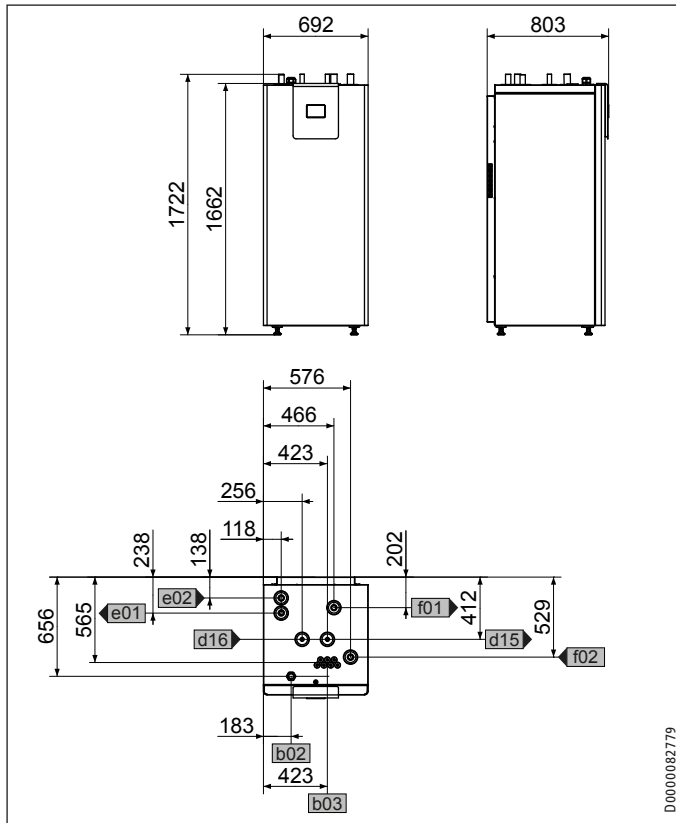

### WPE-I 59 H 400 Premium | WPE-I 87 H 400 Premium

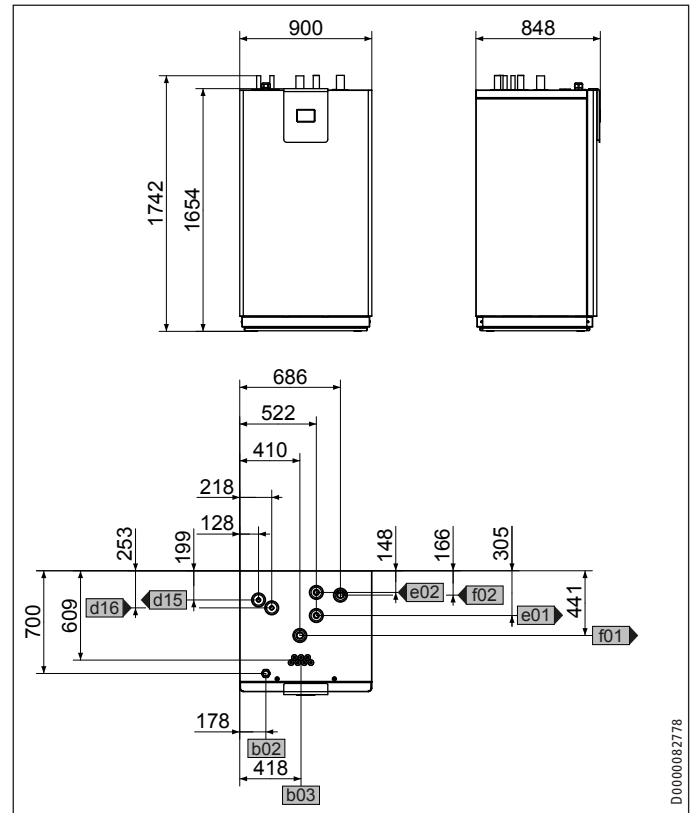

			WPE-I 33 H 400 Premium	WPE-I 44 H 400 Premium	WPE-I 59 H 400 Premium	WPE-I 87 H 400 Premium
b02	Entry electrical cables I					
b03	Entry electrical cables II					
d15	Hot gas DHW flow optional	Diameter	mm	28	28	28
d16	Hot gas DHW return optional	Diameter	mm	28	28	28
e01	Heating flow	Diameter	mm	35	35	42
e02	Heating return	Diameter	mm	35	35	42
f01	Heat source flow	Diameter	mm	42	42	54
f02	Heat source return	Diameter	mm	42	42	54

## 18.4 Wiring diagram

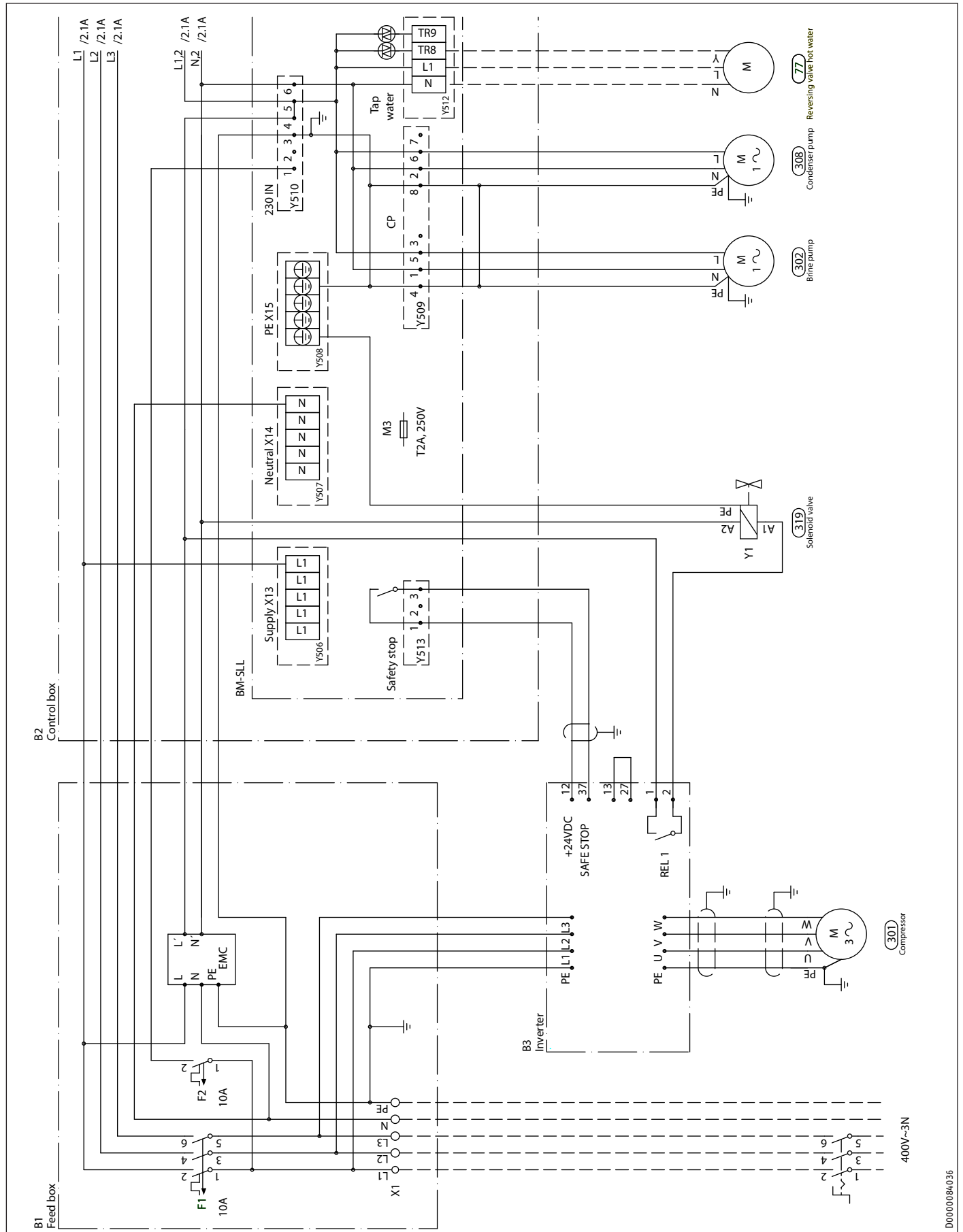

D0000084036

# INSTALLATION Specification

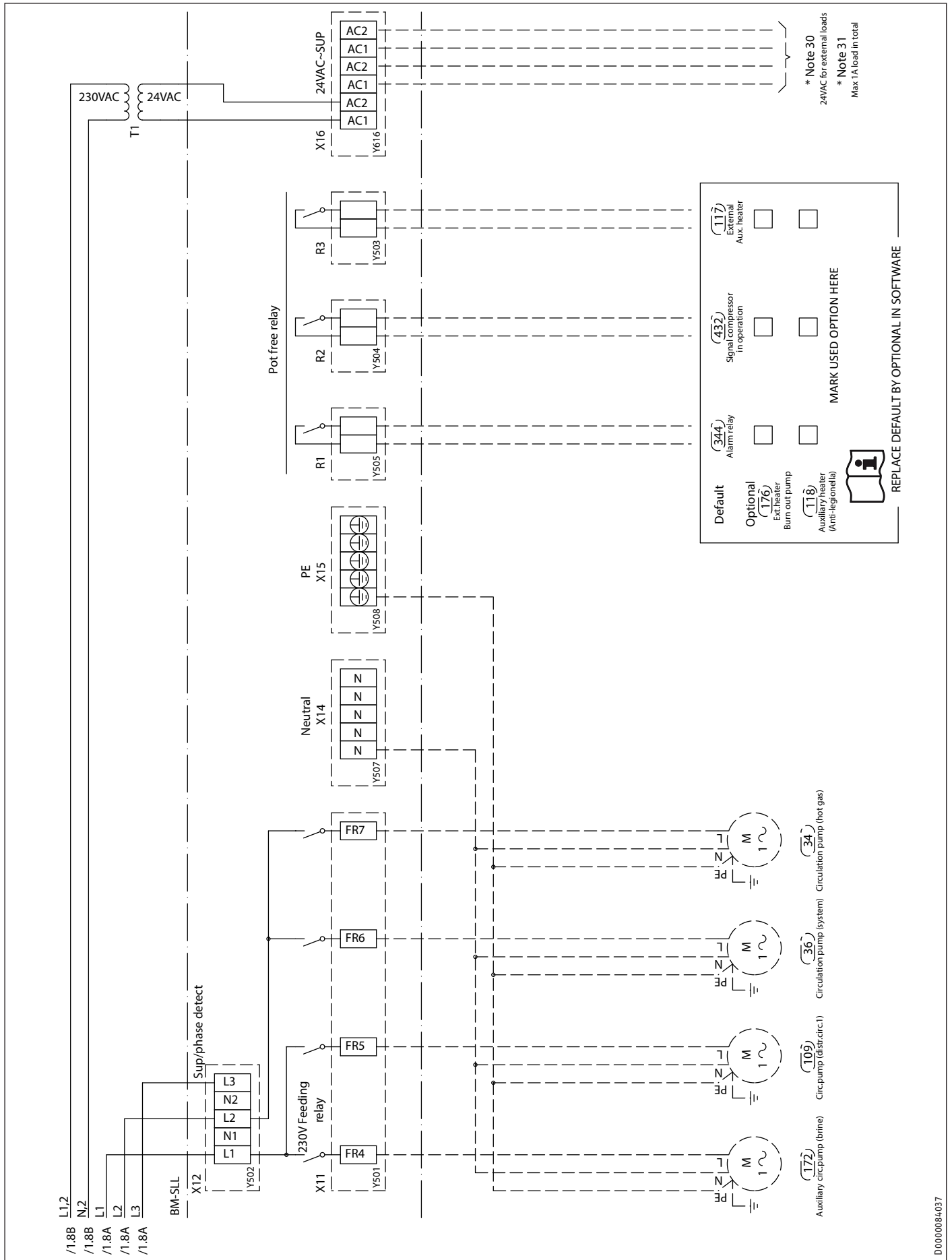

# INSTALLATION Specification

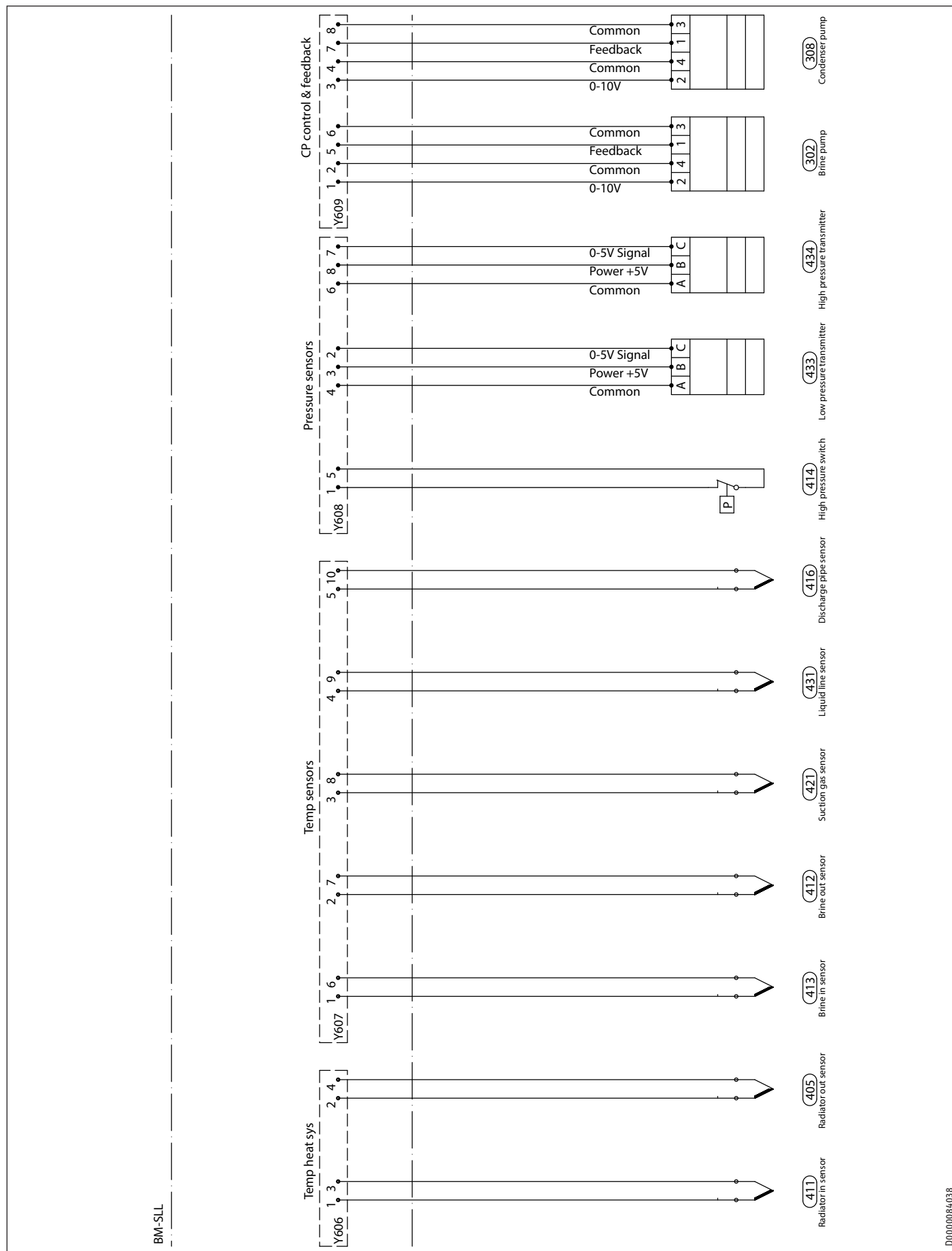

D0000084038

# INSTALLATION Specification

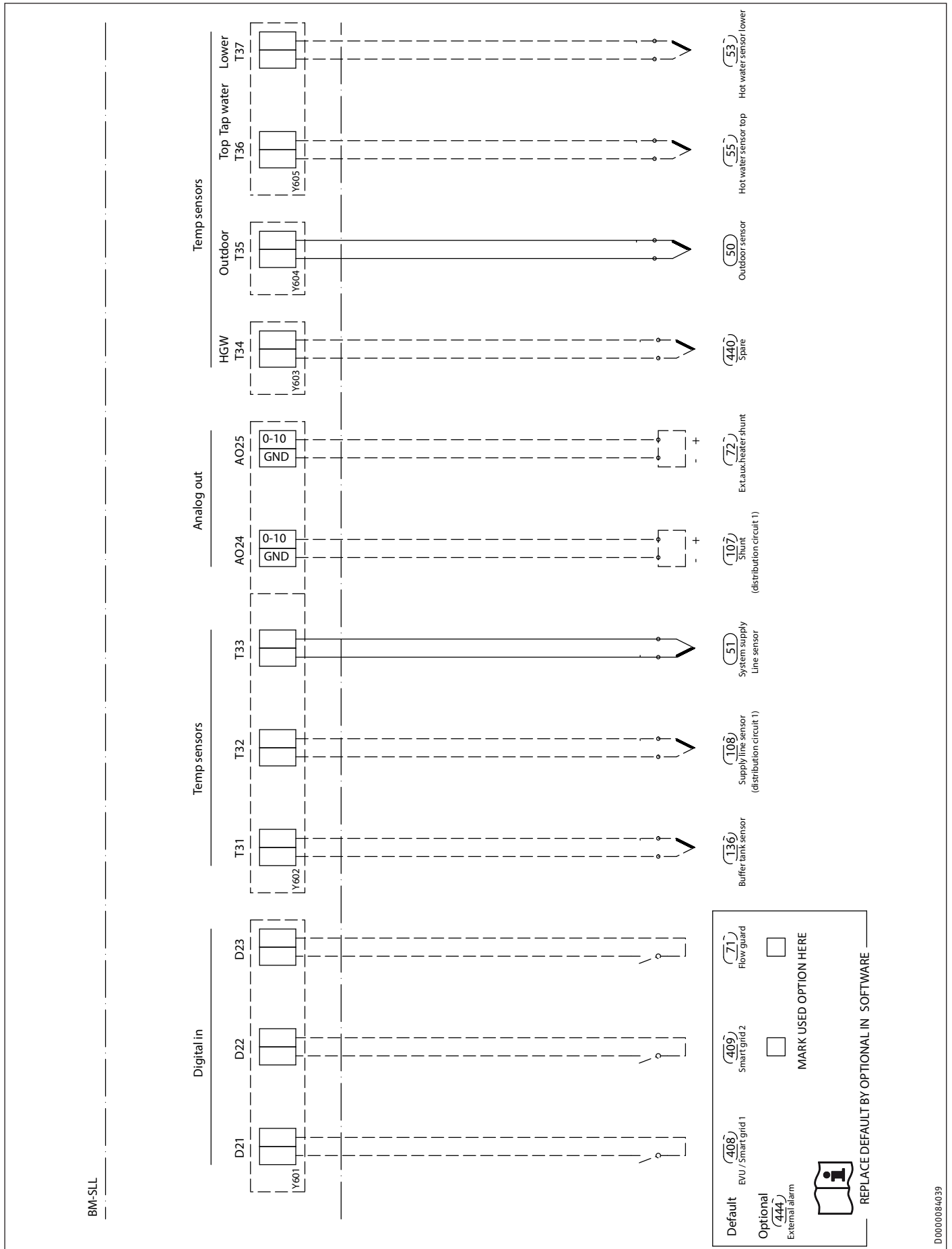

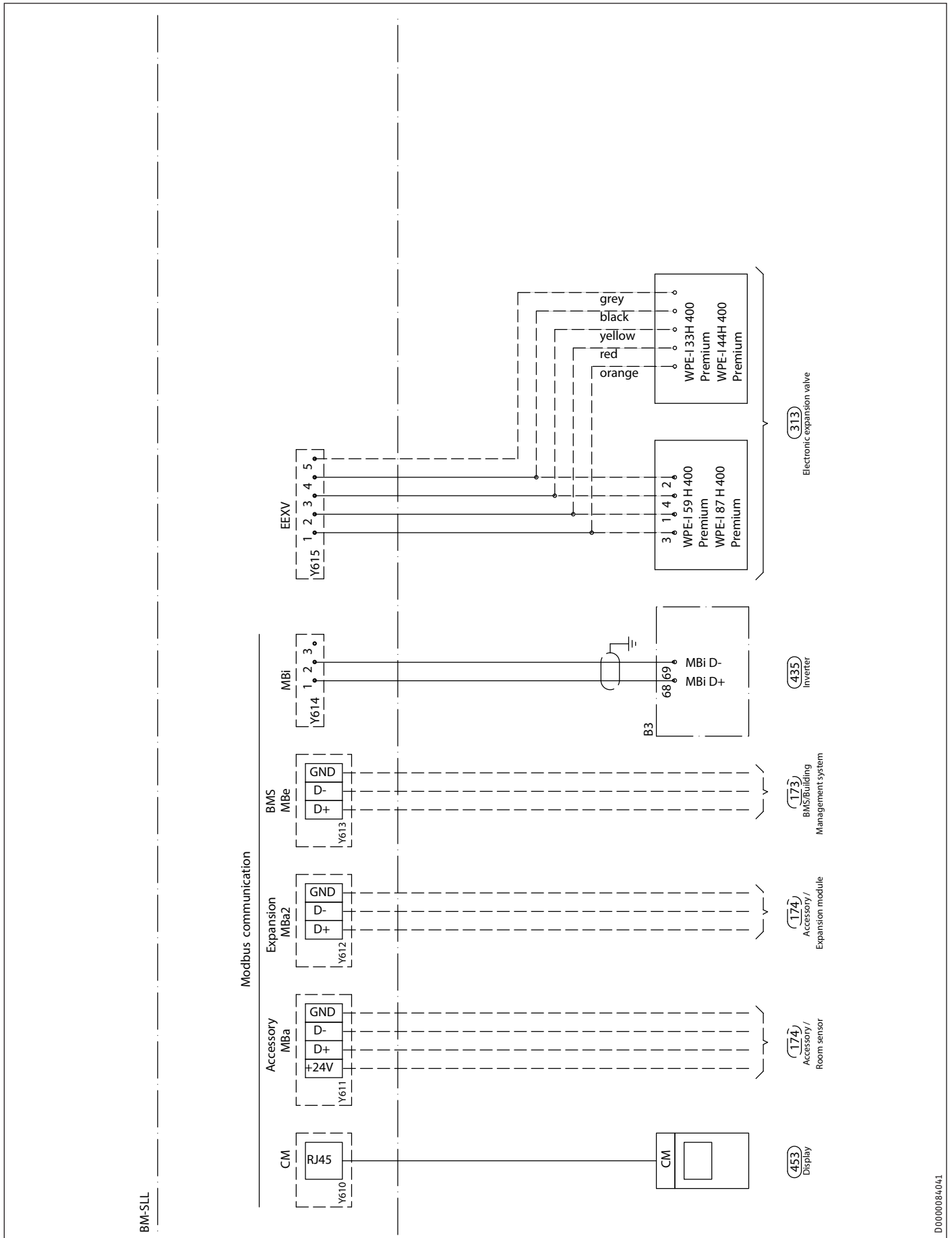

D0000084041



# INSTALLATION Specification

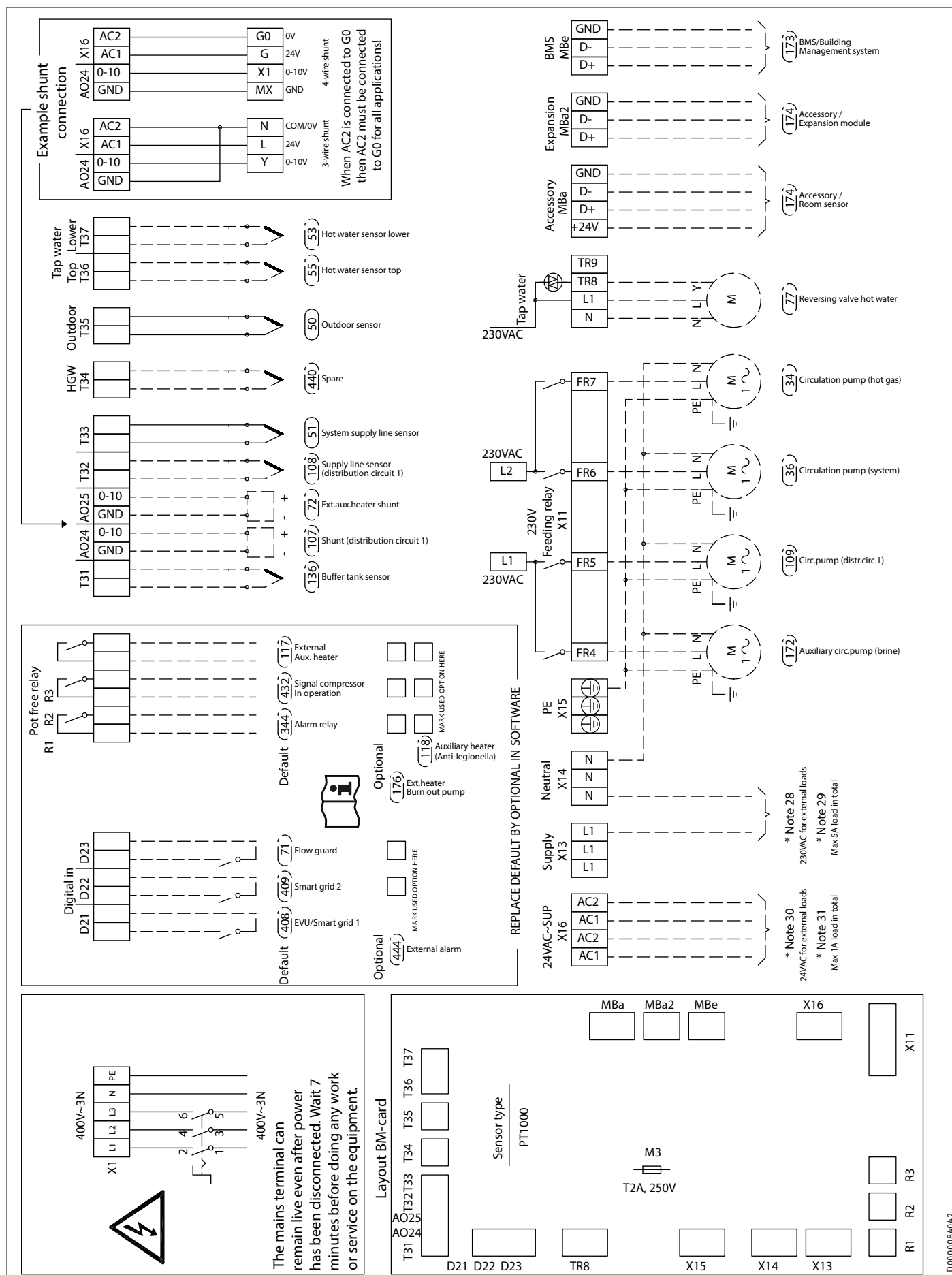

# INSTALLATION

## Specification

### Key

Number	Description
31	Circulation pump (WWZ)
32	Circulation pump (pool)
33	Circulation pump (booster heater incl. mixer control)
34	Circulation pump (hot gas)
35	Circulation pump (WCS)
36	Circulation pump (system)
38	Circulation pump (cooling circuit)
39	Circulation pump (heat dissipation)
40	Expansion card
50	Outside sensor
51	Flow sensor, system
53	DHW temperature sensor, bottom
54	Sensor (WCS)
55	DHW temperature sensor, top
56	Sensor WWZ return
57	Return sensor cooling cylinder
58	Cooling circuit flow sensor
59	Cooling cylinder sensor
60	Pool sensor
61	Return sensor heat dissipation
62	Room temperature sensor
63	DHW temperature sensor
64	Cold water sensor
71	Flow switch
72	External booster heater mixer
73	Mixing valve WCS
74	Mixing valve cooling circuit
75	Mixing valve WW
76	Diverter valve heat dissipation
77	DHW shuttle valve
78	Diverter valve cooling
79	Diverter valve active cooling
101	Valve pool heating
107	Mixer (distributor circuit 1)
108	Flow sensor (distributor circuit 1)
109	Circulation pump (distributor circuit 1)
115	Booster heater, hot water boiler
117	External booster heater
118	Booster heater (anti-legionella function)
119	Control signal dry cooler
132	Passive room sensor
136	Buffer cylinder sensor
143	Return line mixer
170	System circulation pump A
171	System circulation pump B
172	Additional system circulation pump (brine)
173	BMS/Building Management System
174	Accessories
175	Monitoring accessories online
176	External heater burn out pump
180	Cylinder sensor TWC (hot gas heater)
181	Return sensor (cooling circuit)
182	Flow sensor heat dissipation
183	Flow sensor pool
184	Hot gas boiler diverter valve
207	Mixer (distributor circuit 2-5)
208	Flow sensor (distributor circuit 2-5)
209	Circulation pump (distributor circuit 2-5)
210	Flow sensor (distributor circuit 2-5)
250	Mixer pool circuit
301	Compressor
302	Refrigerant pump
304	Replacement circulation pump

Number	Description
308	Condensate pump
310	Diverter valve
312	Bypass valve
313	Electronic expansion valve
317	Booster heater
318	Circulation pump secondary unit
319	Solenoid valve
340	Temperature limiter
341	Start signal
342	External pool off
343	Start WCS external
344	Alarm output
364	DHW mix valve
365	Secondary flow sensor
366	Secondary return sensor
377	Diverter valve volume container
403	Operating pressure switch
405	Sensor heating outlet
407	HGW sensor
408	Power supply utility (PSU)/Smart grid 1
409	Smart grid 2
411	Return sensor heating
412	Refrigerant outlet sensor
413	Refrigerant inlet sensor
414	High pressure switch
416	Sensor drain line
421	Suction gas sensor
422	Dew point sensor
431	Liquid line sensor
432	Signal compressor running
433	Low pressure transmitter
434	High pressure transmitter
435	Inverter
436	DI 1
437	DI 2
438	DI 3
439	DI 4
440	Spare part
441	Communication card
442	Main PCB
443	Sub PCB
444	External alarm
445	DI 5
446	DI 6
447	DI 7
448	DI 8
453	Display
456	Internal hub control
456	Current limiter
* Note 8	Alarm
* Note 9	Speed control
* Note 15	Heating cartridge or external booster heater
* Note 16	Floating contact
* Note 17	To outdoor unit
* Note 18	To extension unit
* Note 19	Communication
* Note 28	230 V AC for outdoor loads
* Note 29	Max. 5 A total load on terminals 38, 39, 50, 52 (50-53 in some models)
* Note 30	24 V AC for external applications
* Note 31	Max. 1 A total load on terminals 54-59 (AC1, AC2 in some models)

---

# INSTALLATION

## Specification

---

Number	Description
* Note 32	The outdoor unit is equipped with a Modbus communication card which is not shown in this wiring diagram. Terminal F1/F2 is connected to the communication card, not to the main PCB.
* Note 33	15 kW booster heater is optional

# INSTALLATION Specification

## 18.5 Output diagrams

### 18.5.1 WPE-I 33 H 400 Premium

#### Heating output

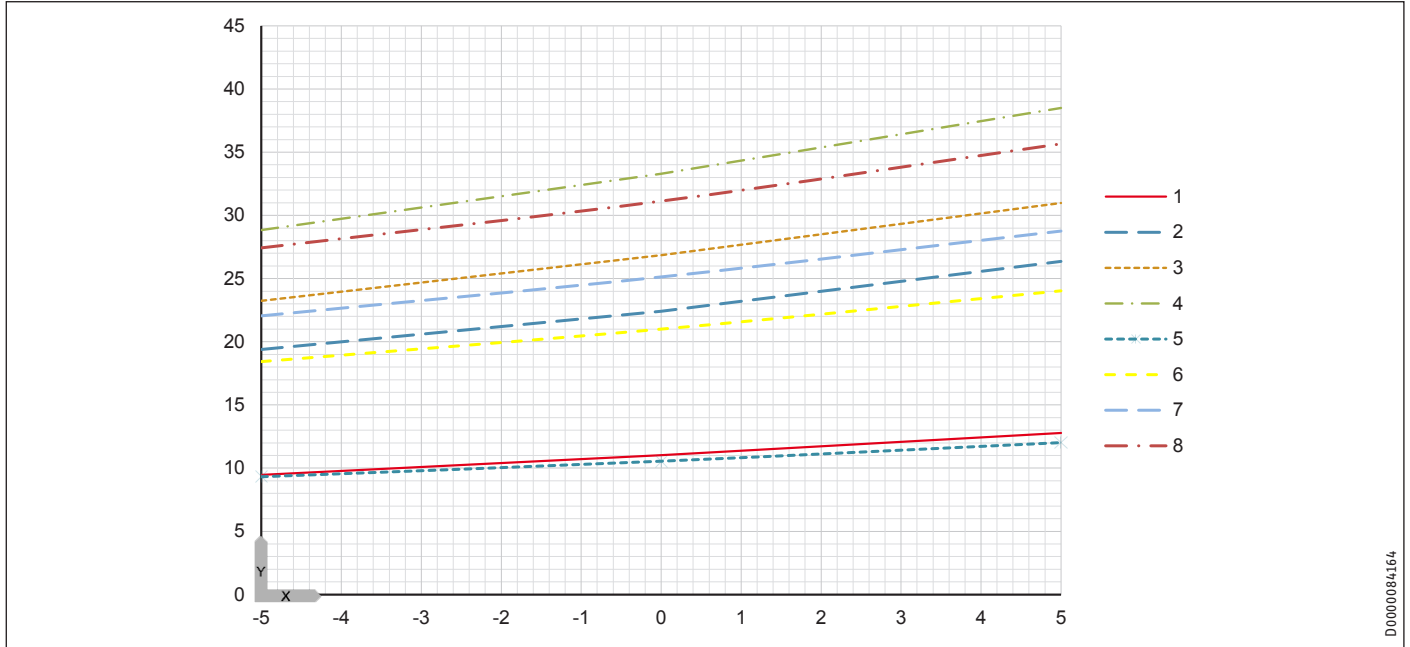

	Flow temperature 35 °C [rpm]		Flow temperature 55 °C [rpm]	
X Temperature of heat source system [°C]	1 1500	3 3600	5 1500	7 3600
Y Heating output [kW]	2 3000	4 4500	6 3000	8 4500

#### Power consumption

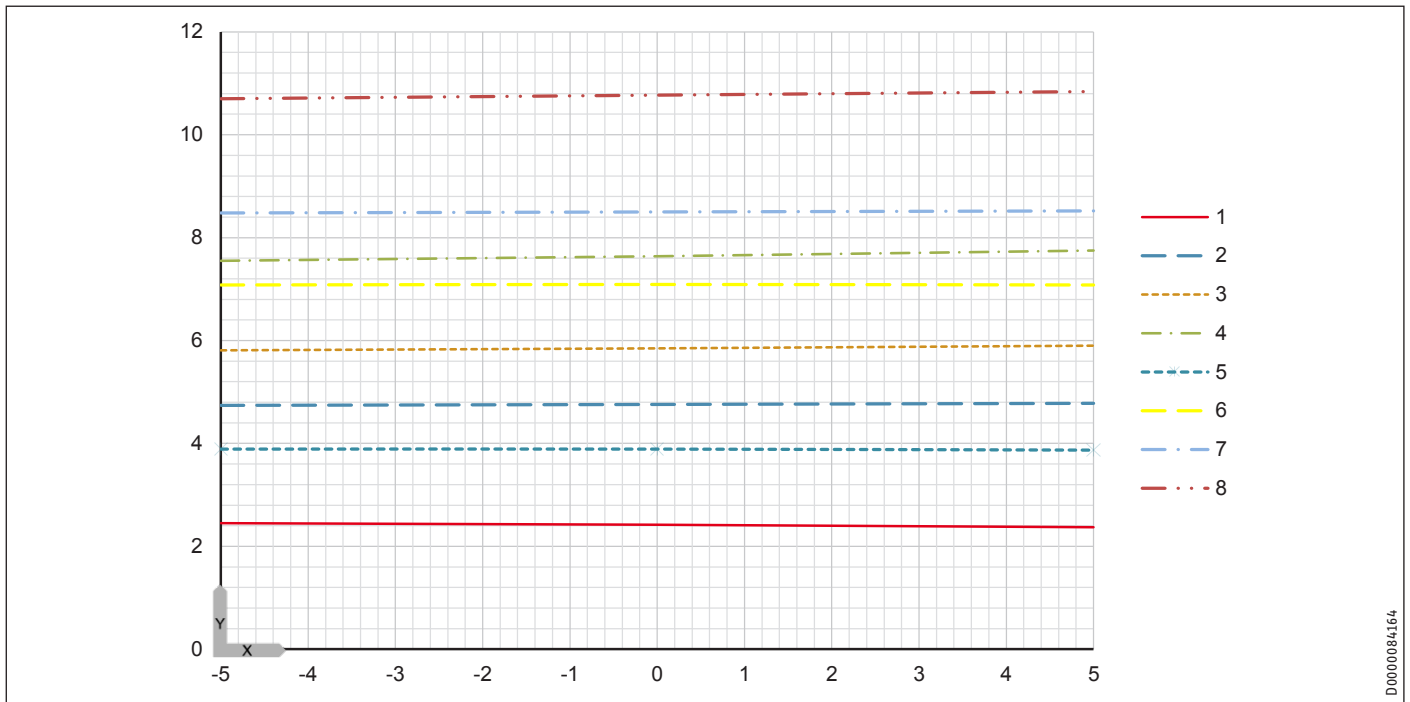

	Flow temperature 35 °C [rpm]		Flow temperature 55 °C [rpm]	
X Temperature of heat source system [°C]	1 1500	3 3600	5 1500	7 3600
Y Power consumption [kW]	2 3000	4 4500	6 3000	8 4500

# INSTALLATION Specification

## Coefficient of performance (COP)

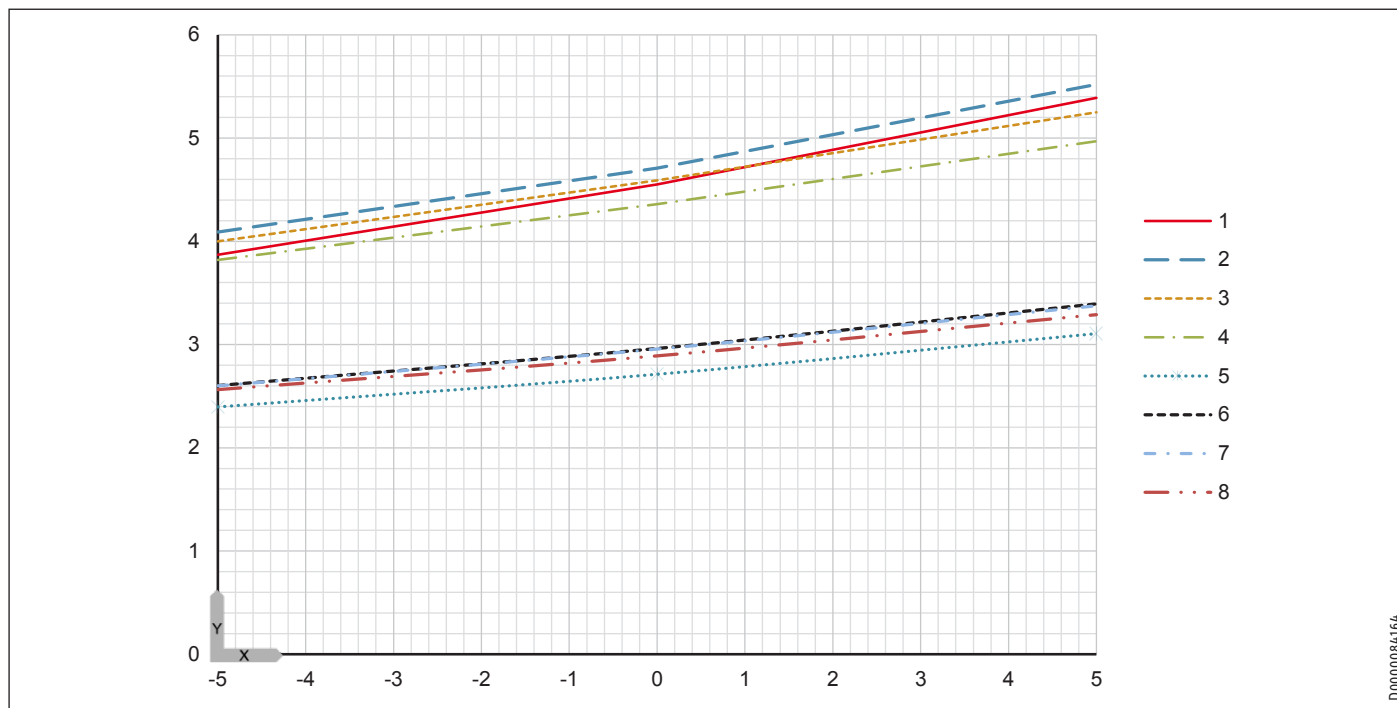

	Flow temperature 35 °C [rpm]		Flow temperature 55 °C [rpm]	
X Temperature of heat source system [°C]	1 1500	3 3600	5 1500	7 3600
Y Coefficient of performance (COP)	2 3000	4 4500	6 3000	8 4500

# INSTALLATION Specification

## 18.5.2 WPE-I 44 H 400 Premium

### Heating output

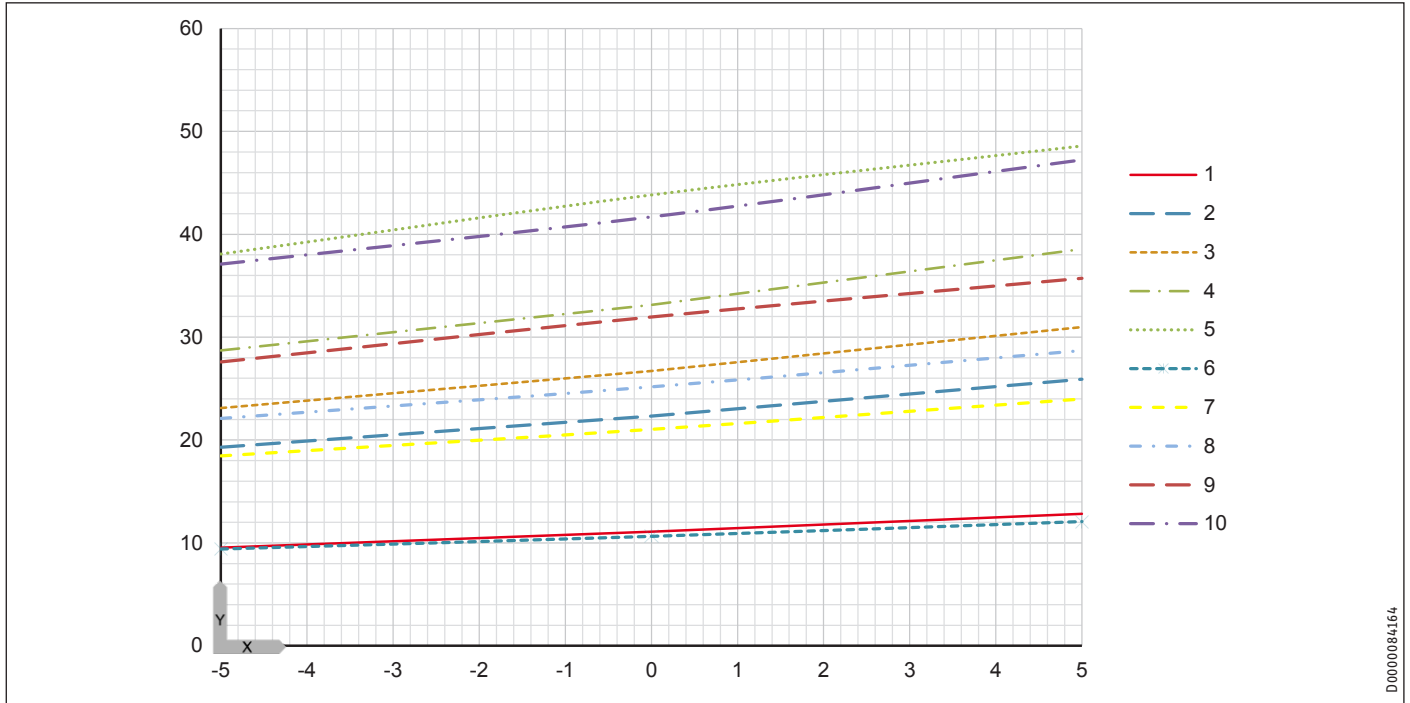

	Flow temperature 35 °C [rpm]			Flow temperature 55 °C [rpm]		
X Temperature of heat source system [°C]	1 1500	3 3600	5 6000	6 1500	8 3600	10 6000
Y Heating output [kW]	2 3000	4 4500		7 3000	9 4500	

### Power consumption

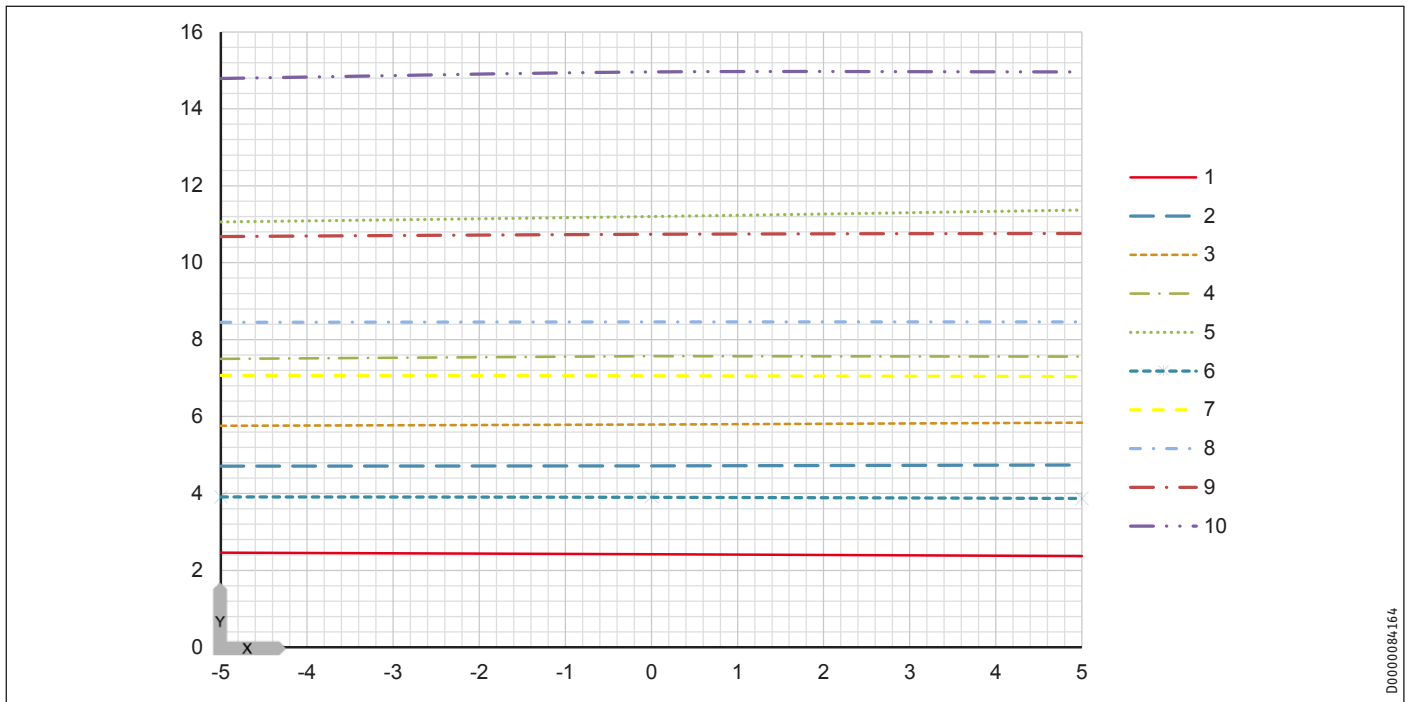

	Flow temperature 35 °C [rpm]			Flow temperature 55 °C [rpm]		
X Temperature of heat source system [°C]	1 1500	3 3600	5 6000	6 1500	8 3600	10 6000
Y Power consumption [kW]	2 3000	4 4500		7 3000	9 4500	

# INSTALLATION Specification

## Coefficient of performance (COP)

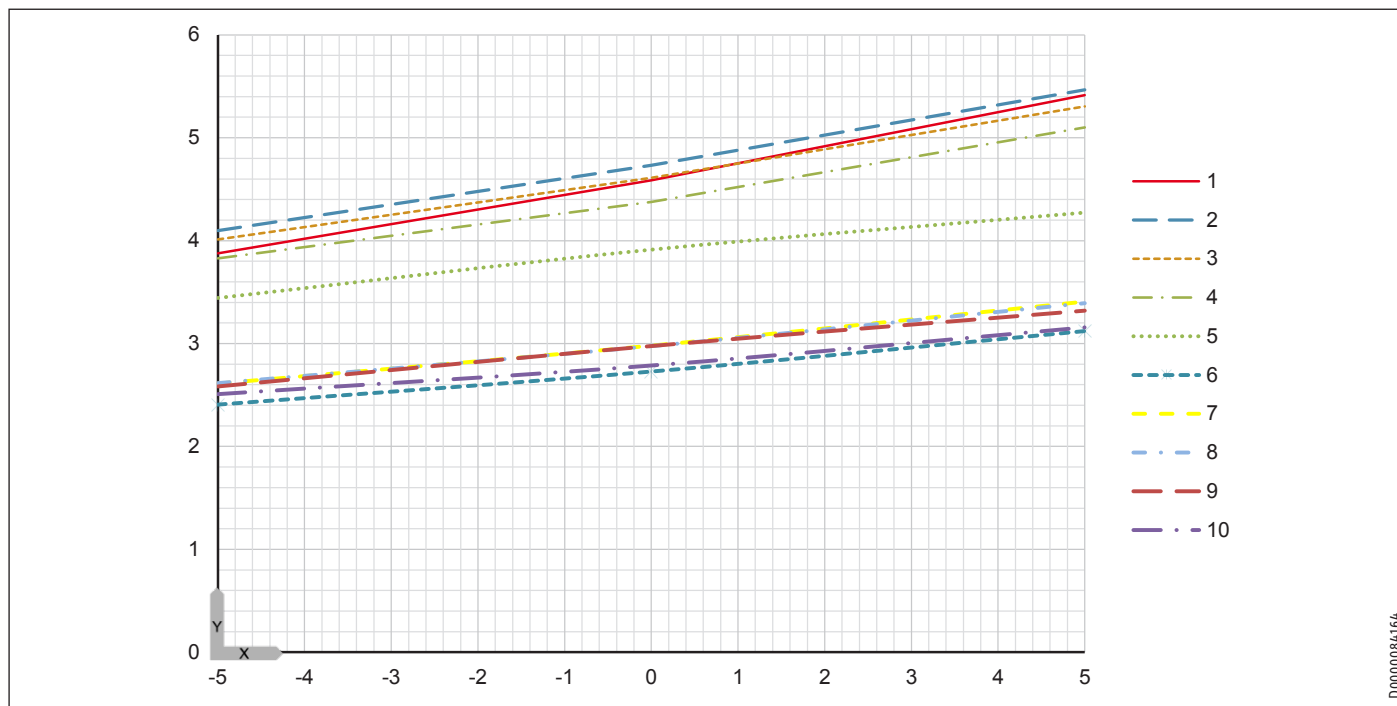

	Flow temperature 35 °C [rpm]			Flow temperature 55 °C [rpm]		
X Temperature of heat source system [°C]	1 1500	3 3600	5 6000	6 1500	8 3600	10 6000
Y Coefficient of performance (COP)	2 3000	4 4500		7 3000	9 4500	

ENGLISH

D000084164

# INSTALLATION Specification

## 18.5.3 WPE-I 59 H 400 Premium

### Heating output

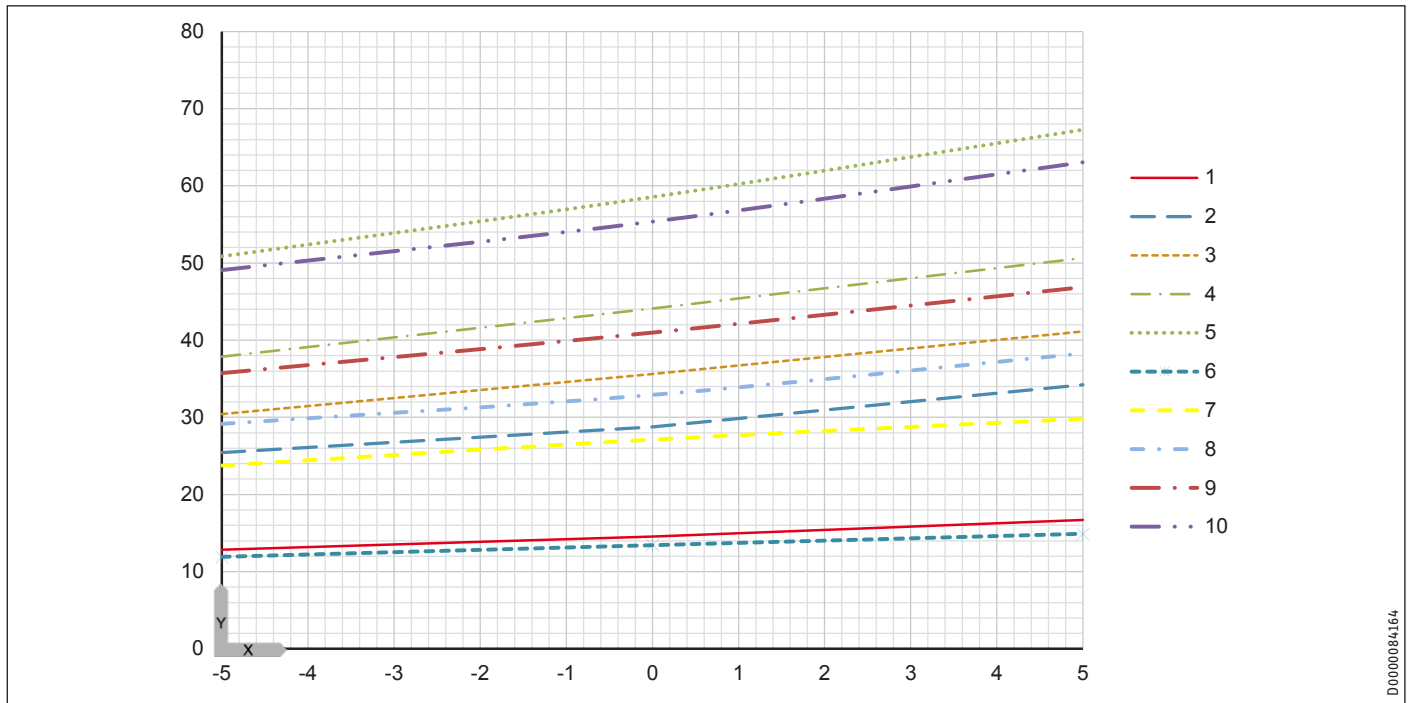

	Flow temperature 35 °C [rpm]			Flow temperature 55 °C [rpm]		
X Temperature of heat source system [°C]	1 1500	3 3600	5 6000	6 1500	8 3600	10 6000
Y Heating output [kW]	2 3000	4 4500		7 3000	9 4500	

### Power consumption

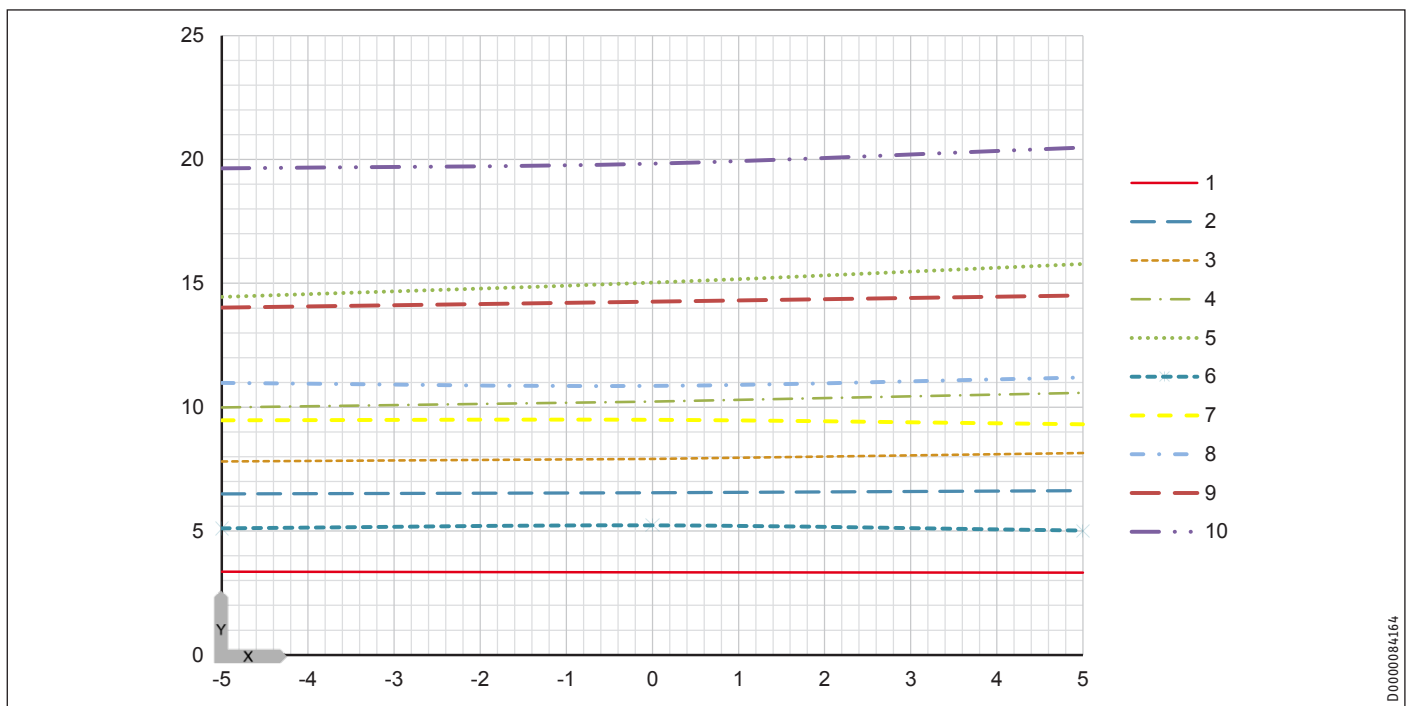

	Flow temperature 35 °C [rpm]			Flow temperature 55 °C [rpm]		
X Temperature of heat source system [°C]	1 1500	3 3600	5 6000	6 1500	8 3600	10 6000
Y Power consumption [kW]	2 3000	4 4500		7 3000	9 4500	



# INSTALLATION Specification

## Coefficient of performance (COP)

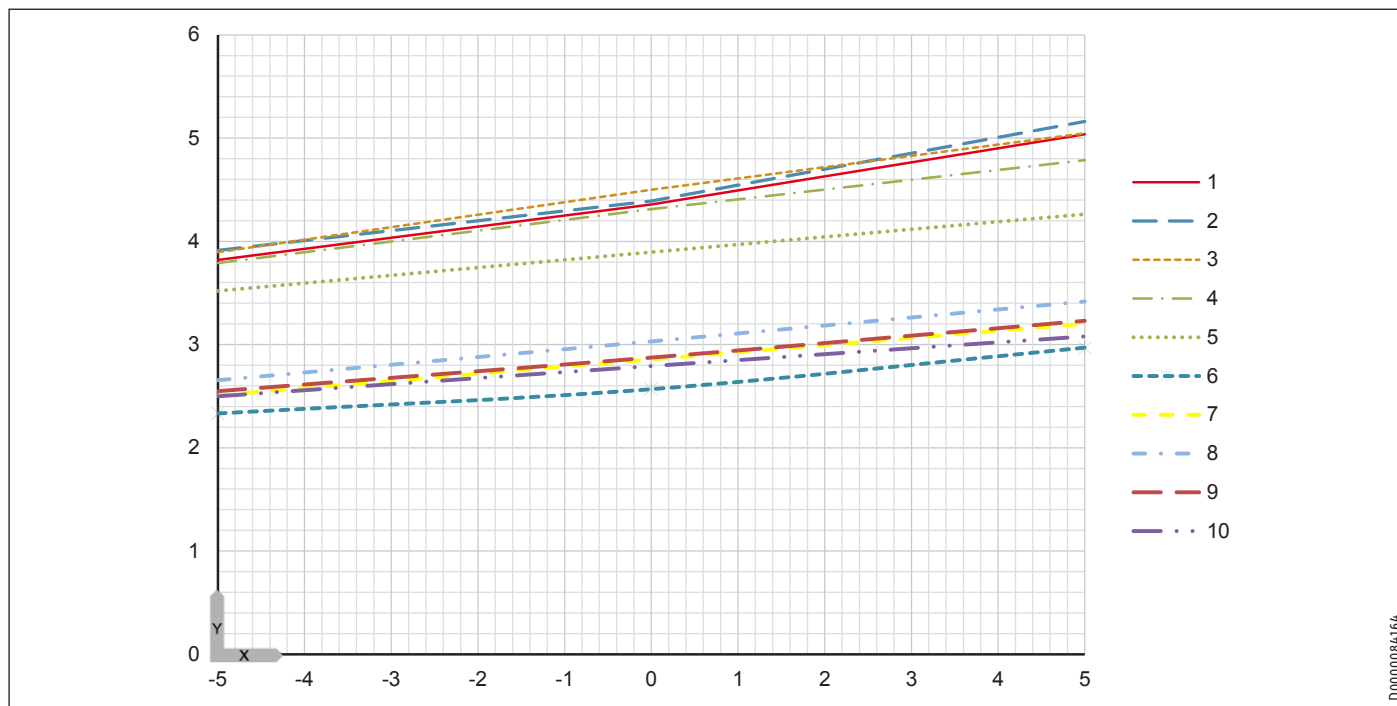

	Flow temperature 35 °C [rpm]			Flow temperature 55 °C [rpm]		
X Temperature of heat source system [°C]	1 1500	3 3600	5 6000	6 1500	8 3600	10 6000
Y Coefficient of performance (COP)	2 3000	4 4500		7 3000	9 4500	

# INSTALLATION Specification

## 18.5.4 WPE-I 87 H 400 Premium

### Heating output

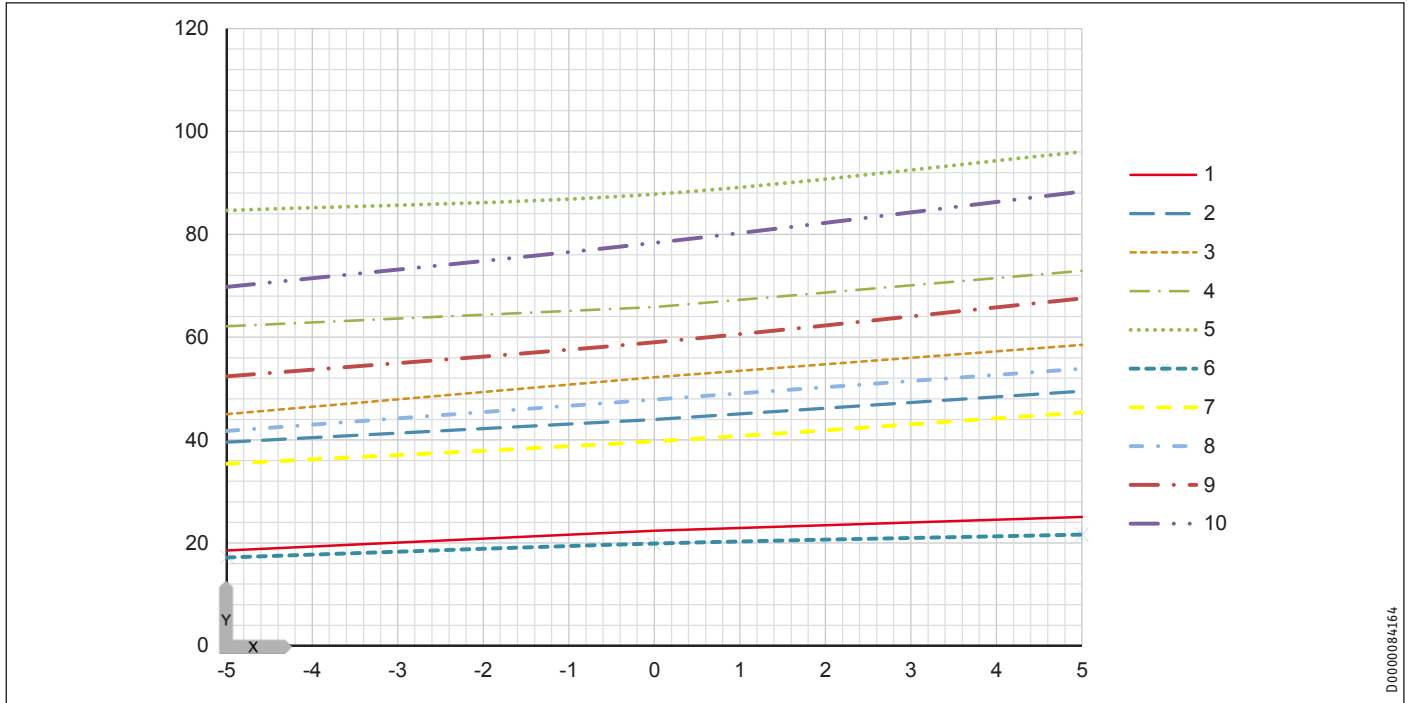

	Flow temperature 35 °C [rpm]			Flow temperature 55 °C [rpm]		
X Temperature of heat source system [°C]	1 1500	3 3600	5 6000	6 1500	8 3600	10 6000
Y Heating output [kW]	2 3000	4 4500		7 3000	9 4500	

### Power consumption

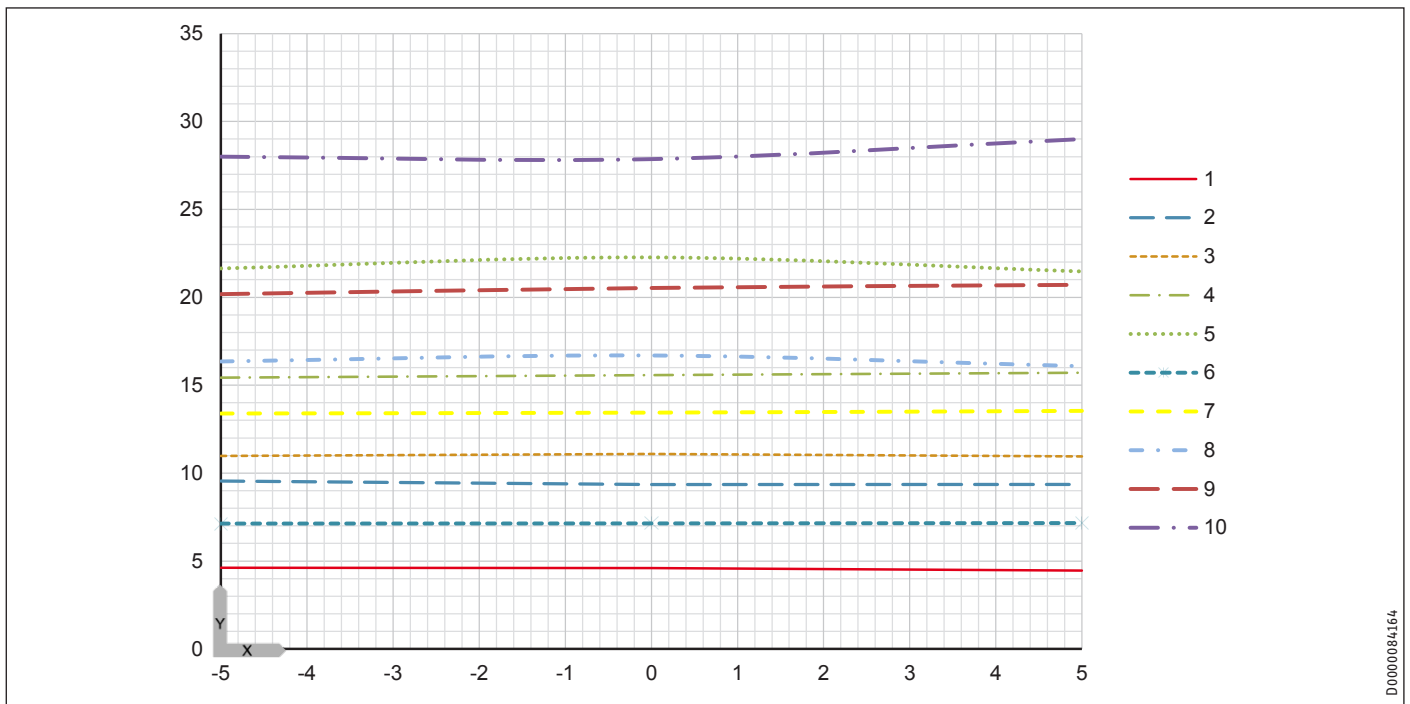

	Flow temperature 35 °C [rpm]			Flow temperature 55 °C [rpm]		
X Temperature of heat source system [°C]	1 1500	3 3600	5 6000	6 1500	8 3600	10 6000
Y Power consumption [kW]	2 3000	4 4500		7 3000	9 4500	

# INSTALLATION Specification

## Coefficient of performance (COP)

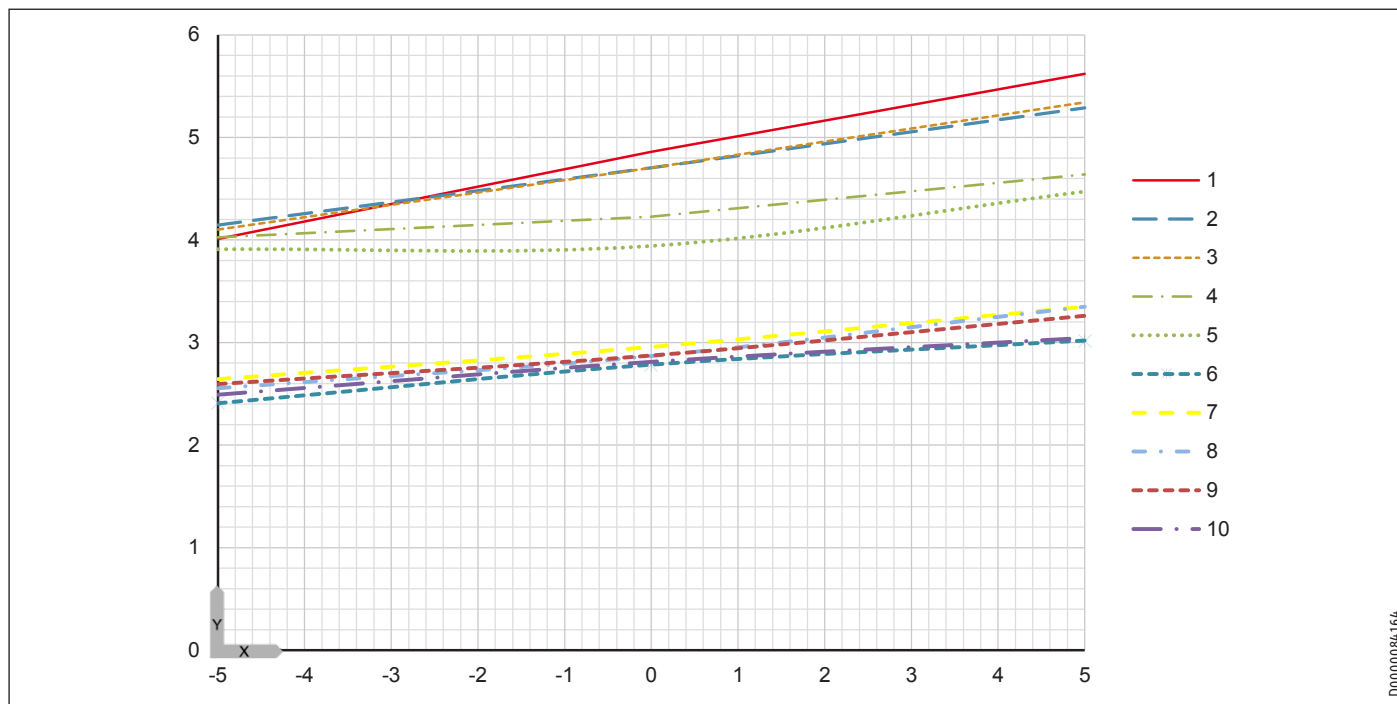

	Flow temperature 35 °C [rpm]			Flow temperature 55 °C [rpm]		
X Temperature of heat source system [°C]	1 1500	3 3600	5 6000	6 1500	8 3600	10 6000
Y Coefficient of performance (COP)	2 3000	4 4500		7 3000	9 4500	

# INSTALLATION Specification

## 18.6 Energy consumption data

### Room heater

Product datasheet: Room heater to regulation (EU) no. 811/2013

		WPE-I 33 H 400 Premium	WPE-I 44 H 400 Premium	WPE-I 59 H 400 Premium	WPE-I 87 H 400 Premium
		201412	201413	201414	201415
		STIEBEL ELTRON	STIEBEL ELTRON	STIEBEL ELTRON	STIEBEL ELTRON
Manufacturer					
Energy efficiency class for central heating in moderate climates for medium temperature applications		A++	A++	A++	A++
Energy efficiency class for central heating in moderate climates for low temperature applications		A++	A++	A++	A++
Rated heating output in moderate climates for medium temperature applications	kW	31	36	55	79
Rated heating output in moderate climates for low temperature applications	kW	33	38	60	85
Energy efficiency for central heating in moderate climates for medium temperature applications	%	159	168	155	157
Energy efficiency for central heating in moderate climates for low temperature applications	%	214	218	200	199
Energy consumption of central heating in moderate climates for medium temperature applications	kWh/a	15305	16768	28063	39457
Energy consumption for central heating under moderate climatic conditions, for low temperature applications	kWh/a	12358	13917	23714	33804
Sound power level internal	dB(A)	47	50	43	50
Special precautionary measures		All specific precautions to be taken during assembly, installation and maintenance are described in the operating and installation instructions..			
Rated heating output in colder climates for medium temperature applications	kW	31	36	55	79
Rated heating output in colder climates for low temperature applications	kW	33	38	60	85
Rated heating output in warmer climates for medium temperature applications	kW	31	36	55	79
Rated heating output in warmer climates for low temperature applications	kW	33	38	60	85
Energy efficiency for central heating in colder climates for medium temperature applications	%	165	174	160	165
Energy efficiency for central heating in colder climates for low temperature applications	%	221	226	204	204
Energy efficiency for central heating in warmer climates for medium temperature applications	%	160	167	157	160
Energy efficiency for central heating in warmer climates for low temperature applications	%	214	220	203	202
Energy consumption for central heating under colder climatic conditions, for medium temperature applications	kWh/a	17698	19290	32491	45048
Energy consumption for central heating under colder climatic conditions, for low temperature applications	kWh/a	14325	16014	27759	39378
Energy consumption for central heating under warmer climatic conditions, for medium temperature applications	kWh/a	9906	10862	17857	23056
Energy consumption for central heating under warmer climatic conditions, for low temperature applications	kWh/a	7963	8920	15055	21524

### Room heater with controller

Product datasheet: Composite system consisting of room heater and temperature controller to regulation (EU) no. 811/2013

		WPE-I 33 H 400 Premium	WPE-I 44 H 400 Premium	WPE-I 59 H 400 Premium	WPE-I 87 H 400 Premium
		201412	201413	201414	201415
		STIEBEL ELTRON	STIEBEL ELTRON	STIEBEL ELTRON	STIEBEL ELTRON
Manufacturer					
Energy efficiency for central heating in moderate climates for medium temperature applications	%	159	168	155	157
Temperature controller class		II	II	II	II
Contribution of temperature controller to room heating energy efficiency	%	2	2	2	2
Room heating energy efficiency of composite system under moderate climatic conditions	%	161	170	157	159
Room heating energy efficiency of composite system under colder climatic conditions	%	167	176	162	167
Room heating energy efficiency of composite system under warmer climatic conditions	%	162	169	159	162

# INSTALLATION

## Specification

Product datasheet: Composite system consisting of room heater and temperature controller to regulation (EU) no. 811/2013

		WPE-I 33 H 400 Premium	WPE-I 44 H 400 Premium	WPE-I 59 H 400 Premium	WPE-I 87 H 400 Premium
Value of differential between room heating energy efficiency under moderate climatic conditions and that under colder climatic conditions	%	6	6	5	8
Value of differential between room heating energy efficiency under warmer climatic conditions and that under moderate climatic conditions	%	1	1	2	3
Energy efficiency class for central heating in moderate climates for medium temperature applications		A++	A++	A++	A++
Room heating energy efficiency class of composite system under moderate climatic conditions		A+++	A+++	A+++	A+++

### Eco-Design

Required details about room heater and combi heater with heat pump to regulation (EU) no. 813/2013

		WPE-I 33 H 400 Premium	WPE-I 44 H 400 Premium	WPE-I 59 H 400 Premium	WPE-I 87 H 400 Premium
		201412	201413	201414	201415
Manufacturer		STIEBEL ELTRON	STIEBEL ELTRON	STIEBEL ELTRON	STIEBEL ELTRON
Heat source		Brine	Brine	Brine	Brine
Low temperature heat pump		-	-	-	-
With booster heater		-	-	-	-
Combi boiler with heat pump		-	-	-	-
Rated heating output in moderate climates for medium temperature applications	kW	31	36	55	79
Tj = -7 °C heating output, partial load range under moderate climatic conditions (Pdh)	kW	27,5	31,5	49	69,9
Tj = 2 °C heating output, partial load range under moderate climatic conditions (Pdh)	kW	16,8	19,2	29,8	42,5
Tj = 7 °C heating output, partial load range under moderate climatic conditions (Pdh)	kW	10,8	12,3	19,2	27,4
Tj = 12 °C heating output, partial load range under moderate climatic conditions (Pdh)	kW	12,2	12,6	16,3	24,1
Tj = dual mode temperature under moderate climatic conditions (Pdh)	kW	12,5	12,4	9,9	9,9
Tj = operating temperature limit under moderate climatic conditions (Pdh)	kW	31,1	35,6	55,3	79
For air/water heat pumps:Tj = -15 °C (if TOL< -20 °C) (Pdh)	kW	31,1	35,6	55,3	79
Tj = -7 °C COP, partial load range under moderate climatic conditions (COPd)		3,14	3,21	3,01	3
Tj = 2 °C COP, partial load range under moderate climatic conditions (COPd)		4,21	4,39	4,11	4,08
Tj = 7 °C COP, partial load range under moderate climatic conditions (COPd)		4,83	5,16	4,66	4,94
Tj = 12 °C COP, partial load range under moderate climatic conditions (COPd)		5	5,34	4,84	5,16
Tj = dual mode temperature under moderate climatic conditions (COPd)		2,86	2,95	2,77	2,72
Tj = operating temperature limit under moderate climatic conditions (COPd)		2,86	2,95	2,77	2,72
For air/water heat pumps:Tj = -15°C (if TOL< -20 °C) (COPd)		2,25	2,21	2,36	2,36
Dual mode temperature (Tbiv)	°C	-10	-10	-10	-10
Operating temperature limit (Tol)	°C	-10	-10	-10	-10
Heating water operating temperature limit (WTOL)	°C	65	65	65	65
Power consumption, OFF state (P <sub>off</sub> )	W	12	7	9	9
Power consumption, thermostat OFF state (P <sub>T0</sub> )	W	12	7	11	11
Standby power consumption (P <sub>SB</sub> )	W	12	7	18	11
Power consumption, operating state, with crankcase heating (P <sub>CK</sub> )	W	0	0	0	0
Booster heater heating output (P <sub>SUB</sub> )	kW	0	0	0	0
Type of energy supply, booster heater		electric	electric	electric	electric
Power control		variable	variable	variable	variable
Sound power level internal	dB(A)	47	50	43	50
Flow rate, heat source side	m <sup>3</sup> /h	4,66	6,01	7,92	11,52

# INSTALLATION Specification

## 18.7 Data table

Output details apply to new appliances with clean heat exchangers.

The power consumption figures for the integral auxiliary drives are maximum values and may vary subject to operating point.

The power consumption of the integral auxiliary drives is included in the output details of the heat pump (to EN 14511).

		WPE-I 33 H 400 Premium 201412	WPE-I 44 H 400 Premium 201413	WPE-I 59 H 400 Premium 201414	WPE-I 87 H 400 Premium 201415
<b>Heating output</b>					
Heating output at B0/W35 (EN 14511)	kW	20.18	26.71	35.60	52.00
Heating output at B0/W35 (min/max)	kW	10 - 33	11 - 44	14 - 59	21 - 87
<b>Power consumption</b>					
Power consumption at B0/W35 (EN 14511)	kW	4.26	5.81	7.91	11.0
<b>Coefficient of performance</b>					
COP at B0/W35 (EN 14511)		4.73	4.60	4.50	4.71
SCOP (EN 14825)		5.55	5.65	5.19	5.17
<b>Sound emissions</b>					
Sound power level (EN 12102)	dB(A)	41-56	41-56	46-61	46-63
<b>Application limits</b>					
Min. application limit on the heating side	°C	20	20	20	20
Max. application limit on the heating side	°C	65	65	65	65
Min. application limit, heat source	°C	-10	-10	-10	-10
Max. application limit, heat source	°C	20	20	20	20
<b>Energy data</b>					
Energy efficiency class		A++/A++	A++/A++	A++/A++	A++/A++
<b>Electrical data</b>					
Frequency	Hz	50	50	50	50
Fuse protection	A	32	40	50	63
Phases		3/N/PE	3/N/PE	3/N/PE	3/N/PE
Rated voltage	V	400	400	400	400
Max. operating current	A	25.2	29.3	39.8	54.2
<b>Versions</b>					
Refrigerant		R410A	R410A	R410A	R410A
Refrigerant charge	kg	3.9	4.4	5.7	8.7
CO <sub>2</sub> equivalent (CO <sub>2</sub> e)	t	8.14	9.19	11.90	18.16
Global warming potential of the refrigerant (GWP100)		2088	2088	2088	2088
Compressor oil		POE	POE	POE	POE
Condenser material		1.4401/Cu	1.4401/Cu	1.4401/Cu	1.4401/Cu
Evaporator material		1.4401/Cu	1.4401/Cu	1.4401/Cu	1.4401/Cu
Circulation pump type on the heating side		Stratos PARA 30/1-8	Stratos PARA 30/1-8	Stratos PARA 30/1-12	Stratos PARA 30/1-12
Circulation pump type, source side		Stratos 40/1-12	Stratos 40/1-12	Stratos 40/1-16	Stratos 40/1-16
<b>Dimensions</b>					
Height	mm	1723	1723	1742	1742
Width	mm	692	692	900	900
Depth	mm	803	803	848	848
<b>Weights</b>					
Weight	kg	300	300	430	550
<b>Connections</b>					
Connection on the heating side		35 mm	35 mm	42 mm	42 mm
Connection on the heat source side		42 mm	42 mm	54 mm	54 mm
Hot gas connection	mm	28	28	28	28
Connecting cable	mm <sup>2</sup>	5 x 6.0	5 x 6.0	5 x 10.0	5 x 10.0
<b>Heating water quality requirements</b>					
Water hardness	°dH	≤3	≤3	≤3	≤3
pH value (with aluminium fittings)		8.0-8.5	8.0-8.5	8.0-8.5	8.0-8.5
pH value (without aluminium fittings)		8.0-10.0	8.0-10.0	8-10.0	8.0-10.0
Chloride	mg/l	<30	<30	<30	<30
Conductivity (softening)	µS/cm	<1000	<1000	<1000	<1000
Conductivity (desalination)	µS/cm	20-100	20-100	20-100	20-100
Oxygen 8-12 weeks after filling (softening)	mg/l	< 0.02	< 0.02	< 0.02	< 0.02
Oxygen 8-12 weeks after filling (desalination)	mg/l	< 0.1	< 0.1	< 0.1	< 0.1

# INSTALLATION

## Specification

		WPE-I 33 H 400 Premium	WPE-I 44 H 400 Premium	WPE-I 59 H 400 Premium	WPE-I 87 H 400 Premium
Heat transfer medium requirements on the heat source side					
Concentration, mono ethylene glycol refrigerant	Vol.-%	25-35	25-35	25-35	25-35
Values					
Permissible refrigerant pressure	MPa	4.5	4.5	4.5	4.5

### Further details

		WPE-I 33 H 400 Premium	WPE-I 44 H 400 Premium	WPE-I 59 H 400 Premium	WPE-I 87 H 400 Premium
		201412	201413	201414	201415
Maximum altitude for installation	m	2000	2000	2000	2000

### 19. Appendix

#### 19.1 Fault table

Message	Class	Description
High pressure switch	A	High pressure switch activated
Low pressure	A	Paused at low pressure, more than 5 times in 5 hours
High discharge temperature	A	Paused at high discharge temperature, more than 3 times in 8 hours
High pressure	A	Paused at operating pressure, more than 5 times in 5 hours
Sensor drain line	A	Sensor alarm
Liquid line sensor	A	Sensor alarm
Suction gas sensor	A	Sensor alarm
Refrigerant flow/pressure low	A	Pressure or flow switch
IO temp. calibration	A	BM card, deviation when calibrating the temperature sensor
IO AI calibration	A	BM card, error deviation when calibrating the transmitter
IO stepper motor	A	BM card, deviating parameters expansion valve motor; recalibrate the machine profile
IO settings	A	The BM card has not been configured correctly in the machine profile menu
IO phase monitoring	A	BM card, one or more phases have dropped out
Inverter (x-x)	A	Inverter alarm, more than 3 stops in 2 hours
Low superheating	A	Paused at low superheating, more than 5 times in 5 hours
Pressure ratio	A	Paused at pressure ratio, high and low pressure side of the compressor, more than 5 times in 5 hours
Outside operating range	A	Paused at operating range limit, more than 5 times in 5 hours
Refrigerant temp.	A	Paused at refrigerant monitoring, more than 5 times in 5 hours
Inverter communication	A	The CM card (control module) has lost the Modbus communication connection to the converter
Machine profile	A	Reconfigure the machine profile menu
No BM card found	A	No BM card detected; a reboot is required
Refrigerant inlet sensor	B	Sensor alarm
Refrigerant outlet sensor	B	Sensor alarm
Condenser inlet sensor	B	Sensor alarm
Condenser outlet sensor	B	Sensor alarm
Outside sensor	B	Sensor alarm
System flow sensor	B	Sensor alarm
Heating circuit sensor 1	B	Sensor alarm
Heating circuit sensor 2	B	Sensor alarm
Heating circuit sensor 3	B	Sensor alarm
Heating circuit sensor 4	B	Sensor alarm
Heating circuit sensor 5	B	Sensor alarm
Heating circuit sensor 6	B	Sensor alarm
Heating circuit sensor 7	B	Sensor alarm
Heating circuit sensor 8	B	Sensor alarm
DHW charge system sensor	B	Sensor alarm
DHW control sensor	B	Sensor alarm
Cool cylinder sensor	B	Sensor alarm
Cooling circuit flow sensor	B	Sensor alarm
Cooling circuit return sensor	B	Sensor alarm
Maximum temperature differential refrigerant	B	Differential refrigerant exceeds the setpoint "Alarm limit brine delta"
Sensor DHW centre	B	Sensor alarm
DHW return	B	Sensor alarm
HGW sensor	B	Sensor alarm
Maximum refrigerant ON temp.	B	The refrigerant ON temperature is above the required limit for the refrigerant monitoring
Minimum refrigerant ON temp.	B	The refrigerant ON temperature is below the required limit for the refrigerant monitoring
Minimum refrigerant OFF temp.	B	The refrigerant OFF temperature is below the required limit for the refrigerant monitoring
Error, humidity sensor (room)	B	Sensor alarm
Flow sensor, surplus heat	B	Sensor alarm
Return sensor, surplus heat	B	Sensor alarm
Return sensor, cooling	B	Sensor alarm
Pool sensor return	B	Sensor alarm
End cylinder sensor DHW	B	Sensor alarm; TWC anti-legionella function must be activated
Max. anti-legionella function time exceeded	B	The anti-legionella function was not completed within 3.5 hours of starting
Buffer cylinder sensor	B	Sensor alarm
TWC return min.	C	Low temperature in circulating water according to alarm settings for TWC DHW return temperature
TWC control min.	C	Low TWC temperature according to alarm settings for TWC DHW flow temperature
Heating circuit 1 control	C	Temperature deviation in accordance with alarm settings for distributor circuit 1



Message	Class	Description
Heating circuit 2 control	C	Temperature deviation in accordance with alarm settings for distributor circuit 2
Heating circuit 3 control	C	Temperature deviation in accordance with alarm settings for distributor circuit 3
Heating circuit 4 control	C	Temperature deviation in accordance with alarm settings for distributor circuit 4
Heating circuit 5 control	C	Temperature deviation in accordance with alarm settings for distributor circuit 5
WCS control	C	Temperature deviation in accordance with alarm settings for WCS
Cooling circuit flow control	C	Temperature deviation in accordance with alarm settings for cooling
Cooling control	C	Temperature deviation in accordance with alarm settings for cooling cylinder
Control, surplus heat	C	Temperature deviation in accordance with alarm settings for surplus heat
Room temperature sensor	C	Room sensor communication error
External alarm	C	Alarm input for external alarm; activation in the menu "Alarm control/central alarm" menu is required
Low system flow temperature	C	Flow temperature below 70 % of the set value for longer than 3 hours
High system supply temp.	C	Flow temperature exceeds the specified limit value (standard: 70 °C)
Error comm. to primary	D	Communication error secondary to primary heat pump
Error comm. to secondary	D	Communication error primary to secondary heat pump
Too few secondary pumps found	D	The number of secondary heat pumps communicating with the primary heat pump is less than expected
Secondary pump class A	D	A secondary heat pump reacting to a class A alarm
Secondary pump class B	D	A secondary heat pump reacting to a class B alarm
Alarm, ext. heat pump pressure switch	E	Operating pressure switch for extension module
Ext. heat pump general error	E	Central alarm from secondary heat pump
Ext. heat pump communication	E	Communication error extension module (to primary heat pump)

### 19.2 Commissioning checklist

 **Note**  
This checklist for commissioning is solely intended to provide assistance to contractors. It is not exhaustive and is subject to change and correction. Contractors are responsible for the services and work they have provided and must observe and comply with the latest technical standards and generally accepted engineering standards.

 **Note**  
Read the operating and installation instructions of the appliances and the accessories carefully before use and retain them for future reference. The checklist cannot replace careful reading of the operating and installation instructions.

	Checkpoint	Reference to the operating and installation instructions	Check-box
<b>Siting</b>	Have the minimum clearances been maintained?	Heat pump: Chapter "Minimum clearances"	<input type="checkbox"/>
	Has the general information on sound and installation location been taken into account?	Heat pump: Chapter "Preparations"	<input type="checkbox"/>
	Have the wall outlets for the hydraulic lines and electric cables been sealed against moisture?	Heat pump: Chapter "Wall outlet"	<input type="checkbox"/>
<b>Hydraulic installation</b>	Was the heat source system flushed thoroughly with brine before the heat pump was connected?	Heat pump: Chapter "Installing the heat source system"	<input type="checkbox"/>
	Was the heating system flushed thoroughly with suitable water before the heat pump was connected?	Heat pump: Chapter "Flow and return connection"	<input type="checkbox"/>
	Have the flow and return been correctly connected to the heat pump and the cylinder or heating system and sufficiently insulated?	Heat pump: Chapter "Flow and return connection"	<input type="checkbox"/>
	Does the water quality correspond to the specifications of the technical data table?	Heat pump: Chapter "Data table"	<input type="checkbox"/>
	Has the heating system been charged to the correct pressure?		<input type="checkbox"/>
	Has the heating system been fully vented at the heat pump and the cylinder or heating system and the air vent valves then closed again?	Heat pump: Chapter "Filling the heating system"	<input type="checkbox"/>
	Have all the pipes in the heating system been sized correctly?		<input type="checkbox"/>
<b>Electrical installation</b>	Has hydronic balancing been carried out?		<input type="checkbox"/>
	Have cables with a sufficient cross-section and the correct fuse protection been used for the electrical connection?	Heat pump: "Data table"	<input type="checkbox"/>
	Has the outside temperature sensor been installed on the correct side of the building (north or north-east wall) and protected from external heating and direct insolation?	Heat pump: Chapter "Sensor installation"	<input type="checkbox"/>
	If cooling is to be provided: Have the room based remote controls been installed in the lead room and connected electrically?		<input type="checkbox"/>
	If cooling is to be provided: Has a buffer cylinder for cooling been installed and connected in the heating system?		<input type="checkbox"/>
	For systems with DHW heating: Have the DHW temperature sensors been properly connected, positioned and programmed at the programming unit?		<input type="checkbox"/>
<b>Initial start-up</b>	Has the heating circuit flow sensor been correctly positioned and connected? (lowest sensor well in the buffer cylinder)		<input type="checkbox"/>
	Has the correct language been set?	Programming unit: Operating instructions, chapter "Setting the language"	<input type="checkbox"/>
	Has the set room temperature been selected?	Programming unit: Operating instructions, chapter "Adjusting the temperature (heating)"	<input type="checkbox"/>
	Has the heating curve been set?	Programming unit: Operating instructions, chapter "Adjusting the temperature (heating)"	<input type="checkbox"/>
	Has the buffer cylinder been configured correctly in the programming unit?	Programming unit: Commissioning instructions, chapter "Controller menu" (Settings / Buffer cylinder)	<input type="checkbox"/>
If cooling is to be provided: Has the heat pump for cooling been enabled and the necessary settings made?	Programming unit: Commissioning instructions, chapter "Controller menu" (Settings / Cooling)	<input type="checkbox"/>	

### **Guarantee**

The guarantee conditions of our German companies do not apply to appliances acquired outside of Germany. In countries where our subsidiaries sell our products a guarantee can only be issued by those subsidiaries. Such guarantee is only granted if the subsidiary has issued its own terms of guarantee. No other guarantee will be granted.

We shall not provide any guarantee for appliances acquired in countries where we have no subsidiary to sell our products. This will not affect warranties issued by any importers.

### **Environment and recycling**

We would ask you to help protect the environment. After use, dispose of the various materials in accordance with national regulations.

## Deutschland

STIEBEL ELTRON GmbH & Co. KG  
Dr.-Stiebel-Straße 33 | 37603 Holzminden  
Tel. 05531 702-0 | Fax 05531 702-480  
info@stiebel-eltron.de  
www.stiebel-eltron.de

## Verkauf

Tel. 05531 702-110 | Fax 05531 702-95108 | info-center@stiebel-eltron.de

## Kundendienst

Tel. 05531 702-111 | Fax 05531 702-95890 | kundendienst@stiebel-eltron.de

## Ersatzteilverkauf

Tel. 05531 702-120 | Fax 05531 702-95335 | ersatzteile@stiebel-eltron.de

## Australia

STIEBEL ELTRON Australia Pty. Ltd.  
294 Salmon Street | Port Melbourne VIC 3207  
Tel. 03 9645-1833 | Fax 03 9645-4366  
info@stiebel.com.au  
www.stiebel.com.au

## Austria

STIEBEL ELTRON Ges.m.b.H.  
Gewerbegebiet Neubau-Nord  
Margaritenstraße 4 A | 4063 Hörsching  
Tel. 07221 74600-0 | Fax 07221 74600-42  
info@stiebel-eltron.at  
www.stiebel-eltron.at

## Belgium

STIEBEL ELTRON bvba/sprl  
't Hofveld 6 - D1 | 1702 Groot-Bijgaarden  
Tel. 02 42322-22 | Fax 02 42322-12  
info@stiebel-eltron.be  
www.stiebel-eltron.be

## China

STIEBEL ELTRON (Tianjin) Electric Appliance Co., Ltd.  
Plant C3, XEDA International Industry City  
Xiqing Economic Development Area  
300085 Tianjin  
Tel. 022 8396 2077 | Fax 022 8396 2075  
info@stiebel-eltron.cn  
www.stiebel-eltron.cn

## Czech Republic

STIEBEL ELTRON spol. s r.o.  
K Hájiřm 946 | 155 00 Praha 5 - Stodůlky  
Tel. 251116-111 | Fax 235512-122  
info@stiebel-eltron.cz  
www.stiebel-eltron.cz

## Finland

STIEBEL ELTRON OY  
Kapinakuja 1 | 04600 Mäntsälä  
Tel. 020 720-9988  
info@stiebel-eltron.fi  
www.stiebel-eltron.fi

## France

STIEBEL ELTRON SAS  
7-9, rue des Selliers  
B.P 85107 | 57073 Metz-Cédex 3  
Tel. 0387 7438-88 | Fax 0387 7468-26  
info@stiebel-eltron.fr  
www.stiebel-eltron.fr

## Hungary

STIEBEL ELTRON Kft.  
Gyár u. 2 | 2040 Budaörs  
Tel. 01 250-6055 | Fax 01 368-8097  
info@stiebel-eltron.hu  
www.stiebel-eltron.hu

## Japan

NIHON STIEBEL Co. Ltd.  
Kowa Kawasaki Nishiguchi Building 8F  
66-2 Horikawa-Cho  
Saiwai-Ku | 212-0013 Kawasaki  
Tel. 044 540-3200 | Fax 044 540-3210  
info@nihonstiebel.co.jp  
www.nihonstiebel.co.jp

## Netherlands

STIEBEL ELTRON Nederland B.V.  
Daviottenweg 36 | 5222 BH 's-Hertogenbosch  
Tel. 073 623-0000 | Fax 073 623-1141  
info@stiebel-eltron.nl  
www.stiebel-eltron.nl

## Poland

STIEBEL ELTRON Polska Sp. z O.O.  
ul. Działkowa 2 | 02-234 Warszawa  
Tel. 022 60920-30 | Fax 022 60920-29  
biuro@stiebel-eltron.pl  
www.stiebel-eltron.pl

## Russia

STIEBEL ELTRON LLC RUSSIA  
Urzhumskaya street 4,  
building 2 | 129343 Moscow  
Tel. 0495 7753889 | Fax 0495 7753887  
info@stiebel-eltron.ru  
www.stiebel-eltron.ru

## Slovakia

TATRAMAT - ohrievače vody s.r.o.  
Hlavná 1 | 058 01 Poprad  
Tel. 052 7127-125 | Fax 052 7127-148  
info@stiebel-eltron.sk  
www.stiebel-eltron.sk

## Switzerland

STIEBEL ELTRON AG  
Industrie West  
Gass 8 | 5242 Lupfig  
Tel. 056 4640-500 | Fax 056 4640-501  
info@stiebel-eltron.ch  
www.stiebel-eltron.ch

## Thailand

STIEBEL ELTRON Asia Ltd.  
469 Moo 2 Tambol Klong-Jik  
Amphur Bangpa-In | 13160 Ayutthaya  
Tel. 035 220088 | Fax 035 221188  
info@stiebel-eltronasia.com  
www.stiebel-eltronasia.com

## United Kingdom and Ireland

STIEBEL ELTRON UK Ltd.  
Unit 12 Stadium Court  
Stadium Road | CH62 3RP Bromborough  
Tel. 0151 346-2300 | Fax 0151 334-2913  
info@stiebel-eltron.co.uk  
www.stiebel-eltron.co.uk

## United States of America

STIEBEL ELTRON, Inc.  
17 West Street | 01088 West Hatfield MA  
Tel. 0413 247-3380 | Fax 0413 247-3369  
info@stiebel-eltron-usa.com  
www.stiebel-eltron-usa.com

**STIEBEL ELTRON**



Irrtum und technische Änderungen vorbehalten! | Subject to errors and technical changes! | Sous réserve d'erreurs et de modifications techniques! | Onder voorbehoud van vergissingen en technische wijzigingen! | Salvo error o modificación técnica! | Excepto erro ou alteração técnica | Zastrzeżone zmiany techniczne i ewentualne błędy | Omyly a technické změny jsou vyhrazeny! | A muszaki változtatások és tévedések jogát fenntartjuk! | Отсутствие ошибок не гарантируется. Возможны технические изменения. | Chyby a technické zmeny sú vyhradené! | Stand 9442