

OPERATION AND INSTALLATION

Integral cylinder

- » HSBC 300 cool
- » HSBC 300 L cool

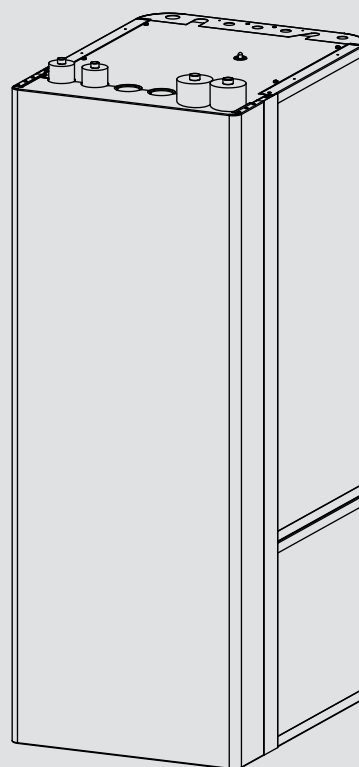

STIEBEL ELTRON

SPECIAL INFORMATION

OPERATION

1. General information	37
1.1 Relevant documents	37
1.2 Safety instructions	37
1.3 Other symbols in this documentation	37
1.4 Information on the appliance	37
1.5 Units of measurement	37
2. Safety	38
2.1 Intended use	38
2.2 General safety instructions	38
2.3 Test symbols	38
3. Appliance compatibility	38
4. Appliance description	38
5. Cleaning, care and maintenance	39
6. Troubleshooting	39

INSTALLATION

7. Safety	40
7.1 General safety instructions	40
7.2 Instructions, standards and regulations	40
8. Appliance description	40
8.1 Standard delivery	40
8.2 Accessories	40
9. Preparation	40
9.1 Installation site	40
9.2 Transport and handling	41
10. Installation	46
10.1 Positioning the appliance	46
10.2 Heating water connection and safety valve	46
10.3 DHW connection and safety assembly	52
10.4 Filling the system	53
10.5 Venting the appliance	54
11. Electrical connection	54
11.1 Control voltage	55
11.2 Safety extra low voltage	56
11.3 Power supply for auxiliary heating element	56
11.4 Sensor installation	56
12. Commissioning	58
12.1 Wilo-Para .../Sc circulation pumps	58
12.2 Appliance handover	59
13. Appliance shutdown	59
14. Maintenance	59
15. Specification	60
15.1 Dimensions and connections	60
15.2 Wiring diagram	62
15.3 Hydraulic diagrams	64
15.4 Energy consumption data	65
15.5 Data table	65
15.6 Accessories	66

GUARANTEE

ENVIRONMENT AND RECYCLING

SPECIAL INFORMATION

- The appliance may be used by children over 8 years of age and persons with reduced physical, sensory or mental capabilities or a lack of experience and expertise, provided that they are supervised or they have been instructed on how to use the appliance safely and have understood the potential risks. Children must never play with the appliance. Children must never clean the appliance or perform user maintenance unless they are supervised.
- The connection to the power supply must be in the form of a permanent connection. Ensure the appliance can be separated from the power supply by an isolator that disconnects all poles with at least 3 mm contact separation.
- Observe all applicable national and regional regulations and instructions.
- Observe minimum distances (see chapter "Installation / Preparations / Installation site").
- Only a qualified contractor should carry out installation, commissioning, maintenance and repair of the appliance.

DHW cylinders

- Drain the appliance as described in chapter "Installation / Maintenance / Draining the DHW cylinder".
- Observe the maximum permissible pressure (see chapter "Installation / Specification / Data table").

OPERATION

1. General information



The chapters "Special information" and "Operation" are intended for both users and qualified contractors.

The chapter "Installation" is intended for qualified contractors.



Note
Read these instructions carefully before using the appliance and retain them for future reference.
Pass on the instructions to a new user if required.

1.1 Relevant documents

-  Operating and installation instructions for the connected heat pump
-  Operating and installation instructions for all other system components



1.2 Safety instructions

1.2.1 Structure of safety instructions



KEYWORD Type of risk
Here, possible consequences are listed that may result from failure to observe the safety instructions.
► Steps to prevent the risk are listed.

1.2.2 Symbols, type of risk

Symbol	Type of risk
	Injury
	Electrocution
	Burns (burns, scalding)



1.2.3 Keywords

KEYWORD	Meaning
DANGER	Failure to observe this information will result in serious injury or death.
WARNING	Failure to observe this information may result in serious injury or death.
CAUTION	Failure to observe this information may result in non-serious or minor injury.

1.3 Other symbols in this documentation









Note
General information is identified by the adjacent symbol.
► Read these texts carefully.

Symbol	Meaning
	Material losses (appliance damage, consequential losses and environmental pollution)
	Appliance disposal

► This symbol indicates that you have to do something. The action you need to take is described step by step.

1.4 Information on the appliance

Connections

Symbol	Meaning	
	Inlet / intake	Red arrow: Hot Blue arrow: Cold Green arrow: Neutral
	Drain / outlet	Red arrow: Hot Blue arrow: Cold Green arrow: Neutral
	Domestic hot water	
	DHW circulation	
	Heat pump	
	Heating	

1.5 Units of measurement



Note
All measurements are given in mm unless stated otherwise.

2. Safety

2.1 Intended use

This appliance is intended to be used for seasonal heating and cooling of interiors (7 °C / 12 °C) and for DHW heating.

The appliance is intended for domestic use. It can be used safely by untrained persons. The appliance can also be used in non-domestic environments, e.g. in small businesses, as long as it is used in the same way.

Any other use beyond that described shall be deemed inappropriate. Observation of these instructions and of the instructions for any accessories used is also part of the correct use of this appliance.

2.2 General safety instructions



WARNING Burns

There is a risk of scalding at outlet temperatures in excess of 43 °C.



WARNING Injury

The appliance may be used by children over 8 years of age and persons with reduced physical, sensory or mental capabilities or a lack of experience and expertise, provided that they are supervised or they have been instructed on how to use the appliance safely and have understood the potential risks. Children must never play with the appliance. Children must never clean the appliance or perform user maintenance unless they are supervised.



WARNING Injury

For safety reasons, only operate the appliance with the front casing closed.



Note

The DHW cylinder is under supply pressure. During the heat-up process, expansion water will drip from the safety valve.

- ▶ If water continues to drip when heating is completed, please inform your qualified contractor.



Material losses

The system's active frost protection is not guaranteed if the power supply is interrupted.

- ▶ Never interrupt the power supply even outside the heating season.

2.3 Test symbols

See type plate on the appliance.

3. Appliance compatibility

The appliance can be operated in conjunction with the following air | water heat pumps:

HSBC 300 cool:

- WPL 10 AC
- WPL 15/20/25 AC(S)
- WPL 19/24 I

HSBC 300 L cool:

- WPL 09/17 ICS/IKCS classic
- WPL 19/24 IK
- WPF 04/05/07/10 (cool)

4. Appliance description

The buffer cylinder and DHW cylinder with indirect coil are arranged one above the other and can be separated for easier handling.

The appliance has a plastic jacket with foam insulation and is equipped with a removable front casing. The appliance is connected hydraulically and electrically to the heat pump. All hydraulic connections are made at the top (heating) and rear (DHW).

In addition to the DHW cylinder and the buffer cylinder, further system components are integrated:

- Highly efficient circulation pump for a heating circuit without mixer
- 3/2-way diverter valve
- Cylinder charging pump (only in HSBC 300 cool)

DHW cylinders

The steel cylinder is coated on the inside with special direct enamel and is equipped with a signal anode. The anode with consumption indicator protects the cylinder interior from corrosion.

The heating water heated by the heat pump is pumped through an indirect coil inside the DHW cylinder. The heat channelled through the indirect coil is thus transferred to the domestic hot water.

Buffer cylinder

The steel cylinder provides hydraulic separation between the flow rates of heat pump and heating circuit. The heating water heated by the heat pump is transferred to the buffer cylinder by the cylinder charging pump (only in HSBC 300 cool). When a demand is issued, the integral heating circuit pump delivers the heating water to the heating circuit.

5. Cleaning, care and maintenance

- ▶ Have the electrical safety of the appliance and the function of the safety assembly regularly checked by a qualified contractor.
- ▶ Never use abrasive or corrosive cleaning agents. A damp cloth is sufficient for cleaning the appliance.

Signal anode with consumption indicator



Material losses

If the consumption indicator changes colour from white to red, have the signal anode checked by a qualified contractor and if necessary replaced.

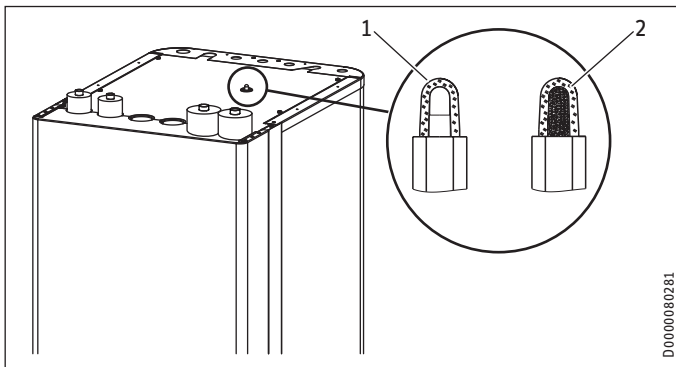

- 1 White = Anode OK
- 2 Red = Requires checking by qualified contractor

Scaling

Almost every type of water will deposit limescale at high temperatures. This settles inside the appliance and affects both performance and service life. A qualified contractor who knows the local water quality will tell you when the next service is due.

- ▶ Check the taps regularly. Limescale deposits at the tap outlets can be removed using commercially available descaling agents.
- ▶ Regularly activate the safety valve to prevent it from becoming blocked, e.g. by limescale deposits.

6. Troubleshooting

Problem	Cause	Remedy
The water does not heat up. The heating does not work.	There is no power.	Check the fuses/MCBs in your fuse box/distribution board.

If you cannot remedy the fault, contact your qualified contractor. To facilitate and speed up your enquiry, please provide the serial number from the type plate (000000-0000-000000).

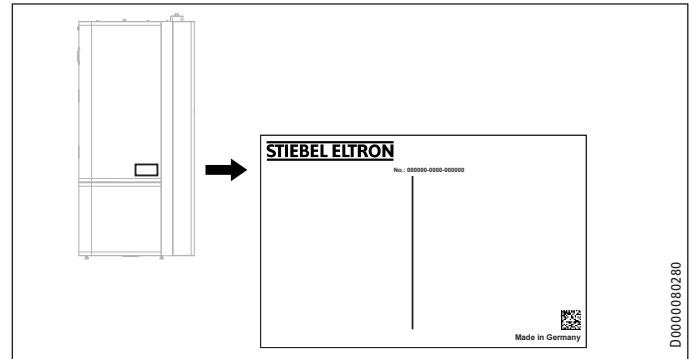

INSTALLATION

7. Safety

Only a qualified contractor should carry out installation, commissioning, maintenance and repair of the appliance.

7.1 General safety instructions

We guarantee trouble-free function and operational reliability only if original accessories and spare parts intended for the appliance are used.

7.2 Instructions, standards and regulations



Note

Observe all applicable national and regional regulations and instructions.

8. Appliance description

8.1 Standard delivery

The following are delivered with the appliance:

- 4 adjustable feet

Only HSBC 300 L cool:

- 2 copper adaptors (28/28/28 mm, for joining flow and return)
- 4 copper reducers (28/22 mm)

8.2 Accessories

8.2.1 Required accessories

Safety assemblies and pressure reducing valves are available to suit the prevailing supply pressure. These type-tested safety assemblies protect the appliance against impermissible excess pressure.

8.2.2 Additional accessories

- Pump assembly for a heating circuit with mixer HSBC 3-HKM
- Pipe assembly RBS-SBC
- Auxiliary heating element HSBC 3-HE
- Pressure hoses
- Water softening fitting HZEA
- Temperature sensor for cooling

Pipe assembly RBS-SBC

The hydraulic connections can be routed upwards at the rear of the DHW cylinder using the RBS-SBC pipe assembly available as an accessory.

9. Preparation

9.1 Installation site



Material losses

Never install the appliance in wet rooms.

Install the appliance near the draw-off point in a dry room free from the risk of frost. To reduce line losses, keep the distance short between the appliance and the heat pump.

Ensure the floor has sufficient load bearing capacity and evenness (for weight, see chapter "Specification / Data table").

The room must not be subject to a risk of explosions arising from dust, gases or vapours.

If you are installing the appliance in a boiler room together with other heating equipment, ensure that the operation of the other heating equipment will not be impaired.

Minimum clearances

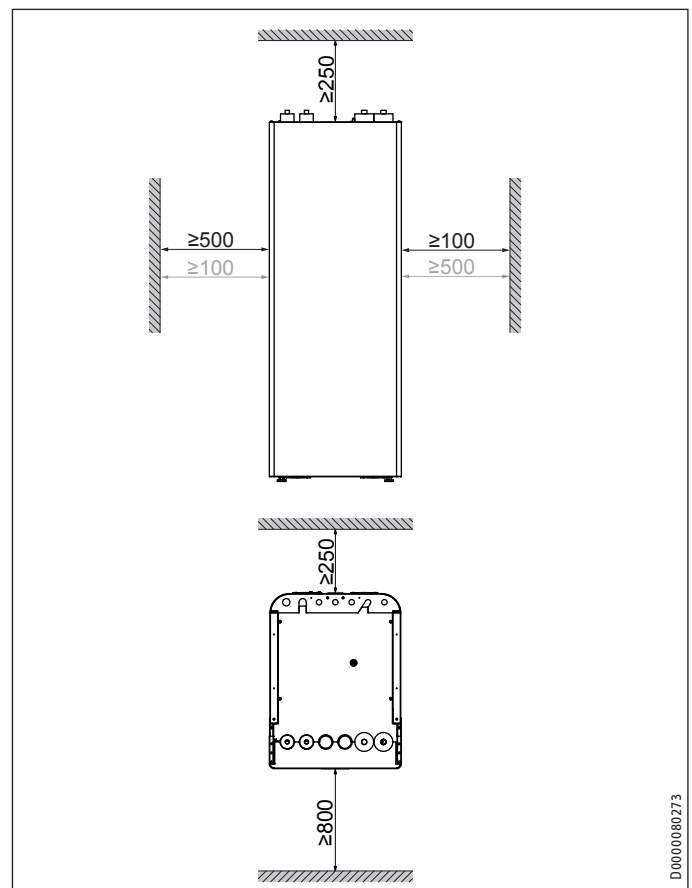

The minimum side clearances can be swapped between left and right.

INSTALLATION

Preparation

9.2 Transport and handling



Material losses

Store and transport the appliance at temperatures between -20 °C and +60 °C.

Handling

- ▶ Undo the 4 screws from the non-returnable pallet.

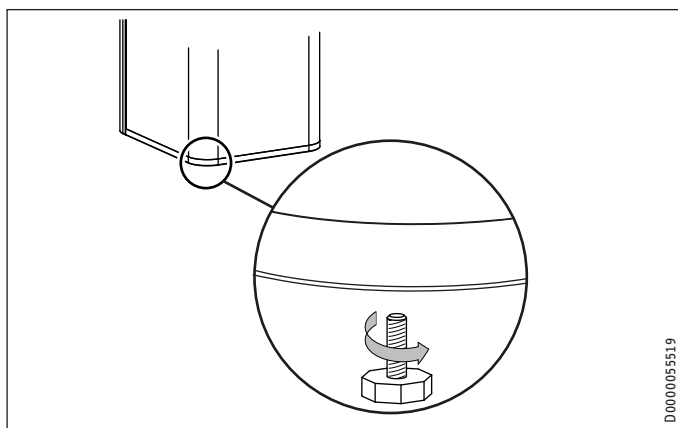

D0000055519

- ▶ Tilt the appliance and screw the 4 adjustable feet into the appliance.
- ▶ Lift the appliance off the pallet.

If narrow doors or hallways hinder handling, you can separate the upper and lower sections of the appliance as described in the following chapters.

9.2.1 Removing / fitting the front casing

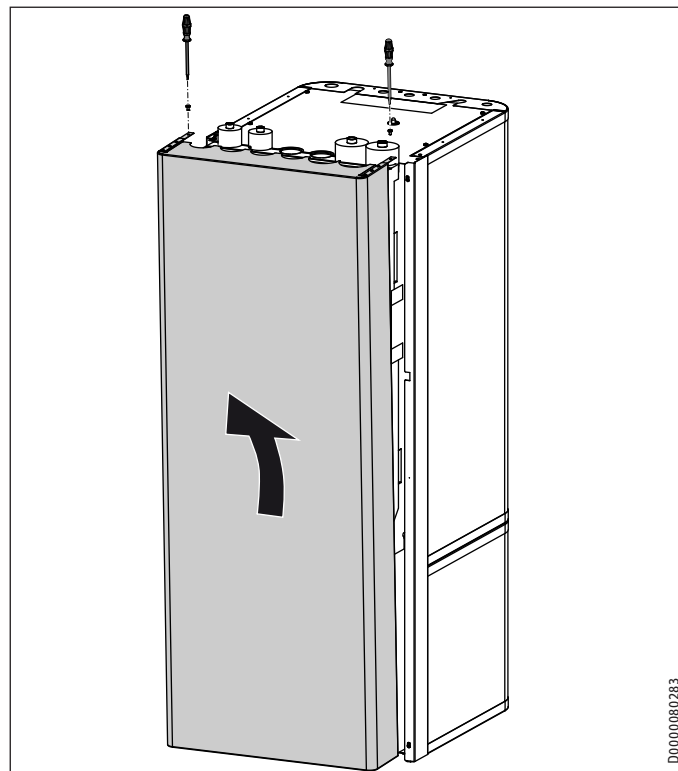

D0000080283

- ▶ Remove the 2 locking screws on the top of the front casing.
- ▶ Unhook the front casing towards the top.
- ▶ Remove the earth cable from the front casing.
- ▶ Fit the front casing in reverse order.

ENGLISH

INSTALLATION

Preparation

9.2.2 Overview of insulation segments

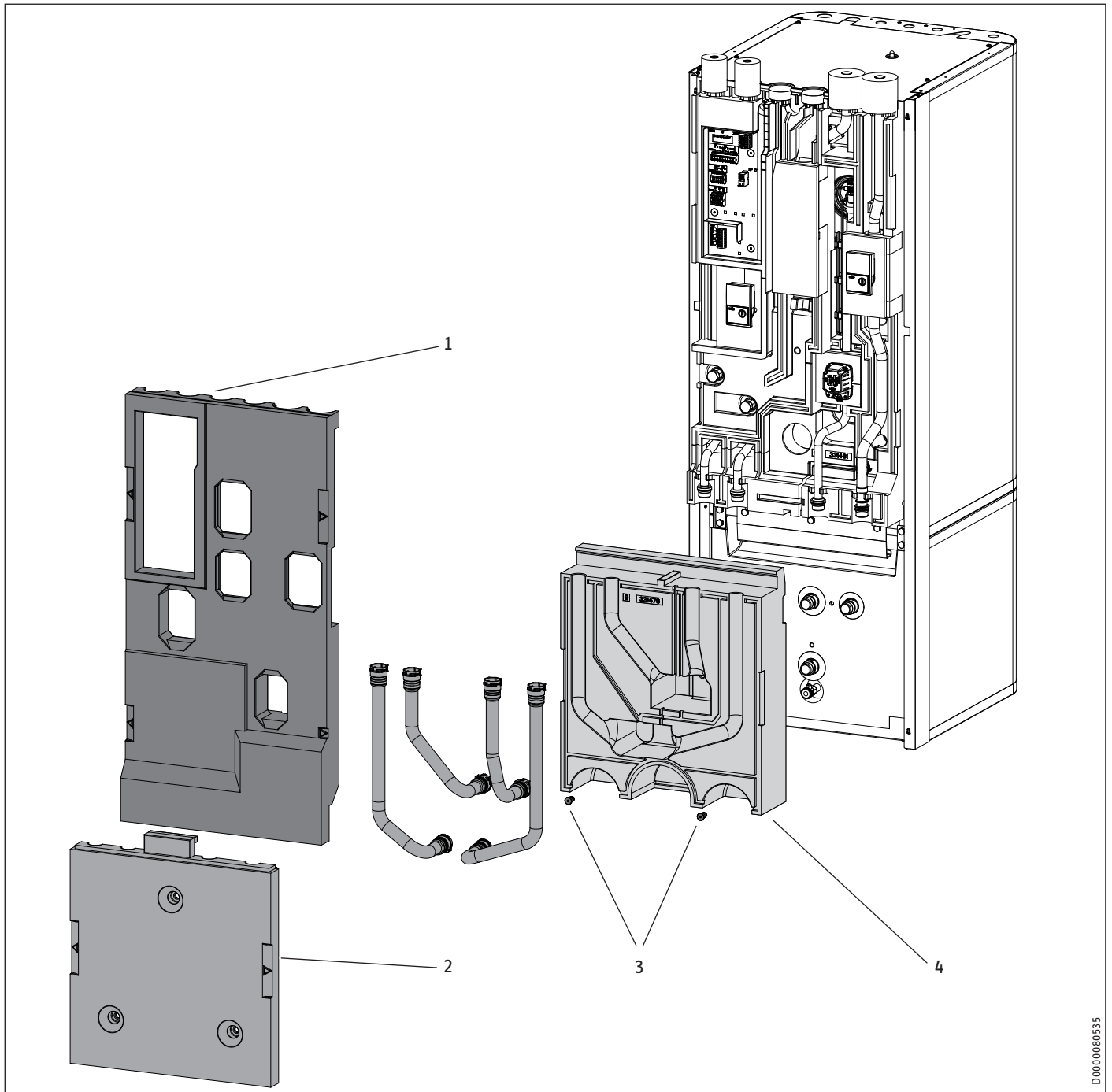

- 1 Insulation segment 1
- 2 Insulation segment 2
- 3 Insulation material screw
- 4 Insulation segment 3

D0000080535

INSTALLATION

Preparation

9.2.3 Separating / joining the appliance sections

Separating the appliance sections

- ! Material losses**
 Unscrewing the fastening screws destroys the threads in the insulation segment.
- ▶ To open the 3 fixing tabs, loosen the fastening screws slightly but do not unscrew them completely.

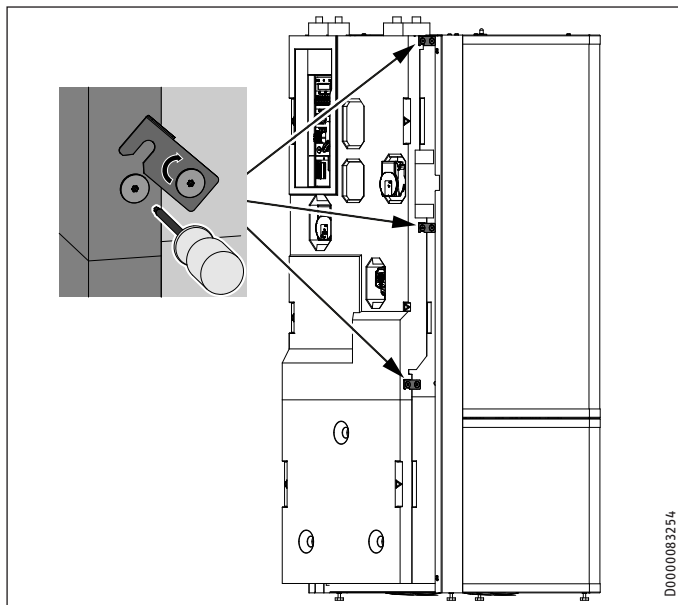

D0000083254

- Note**
 To make removal simpler, the insulation segments have labelled recessed grips on the left and right.

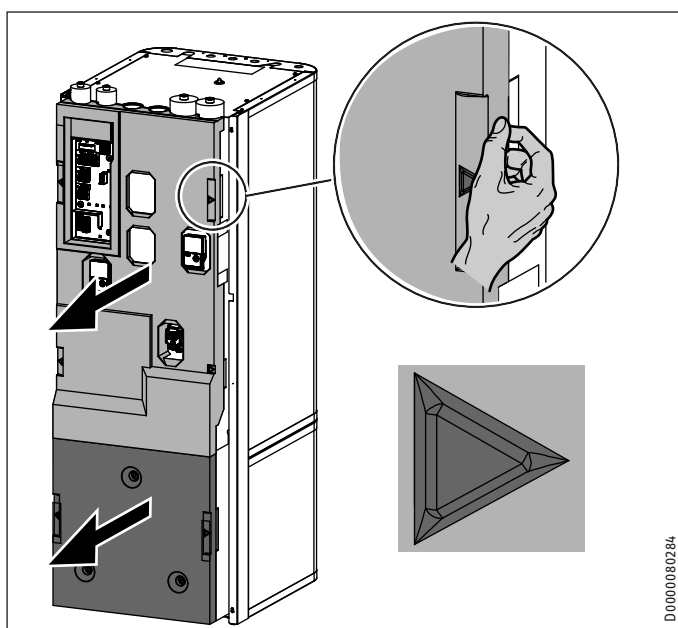

D0000080284

- ▶ Remove insulation segment 1.
- ▶ Remove insulation segment 2.

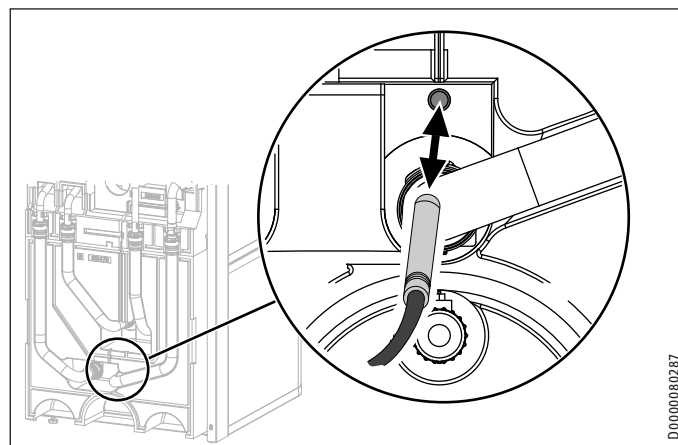

D0000080287

- ▶ Pull the "heating sensor" out of the buffer cylinder.

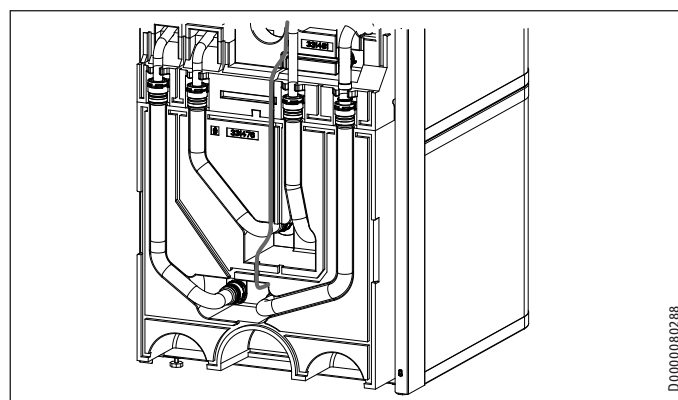

D0000080288

- ▶ Release the sensor lead from the guide groove.

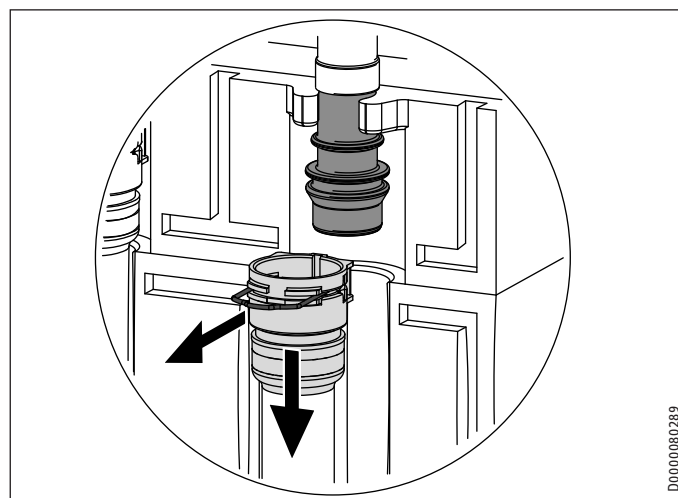

D0000080289

- ▶ Disconnect the push-fit connectors of the 4 hydraulic connections. To do this, pull the spring clips fully out with a screwdriver.
- ▶ Pull the hydraulic connectors as indicated.

INSTALLATION

Preparation

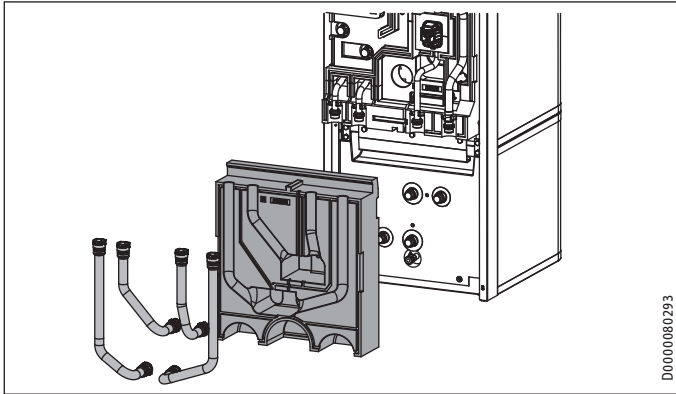

- ▶ Remove the 4 hydraulic hoses.
- ▶ Remove the 2 insulation material screws.
- ▶ Remove insulation segment 3.

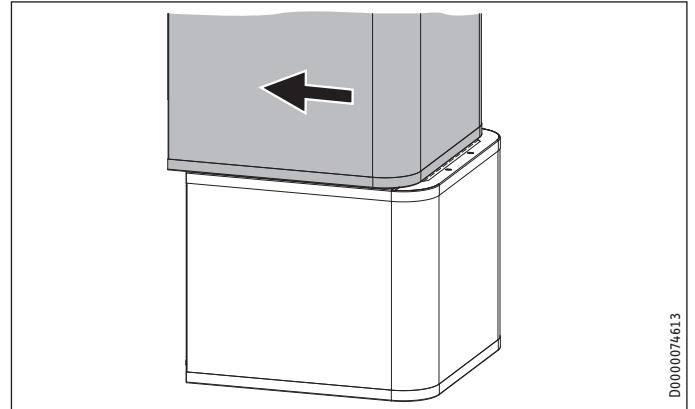

- ▶ Pull the upper section of the appliance towards the front.

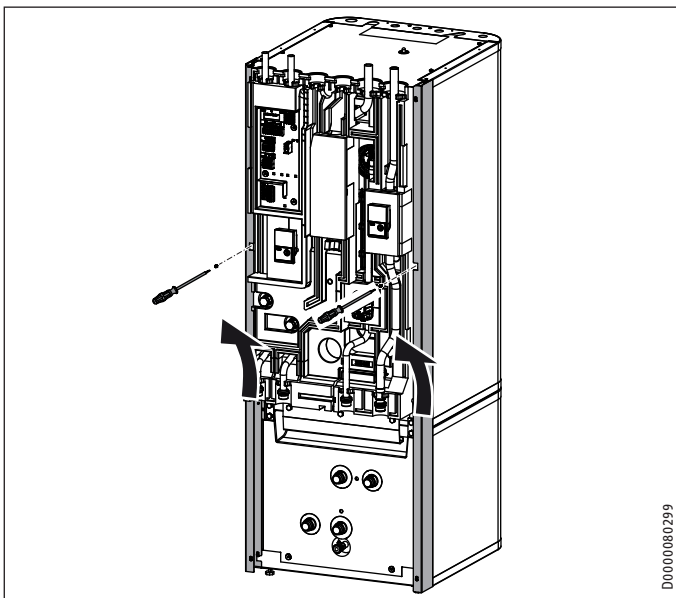

- ▶ Undo the 2 locking screws on the side profile strips.
- ▶ Lift up and unhook the side profile strips.

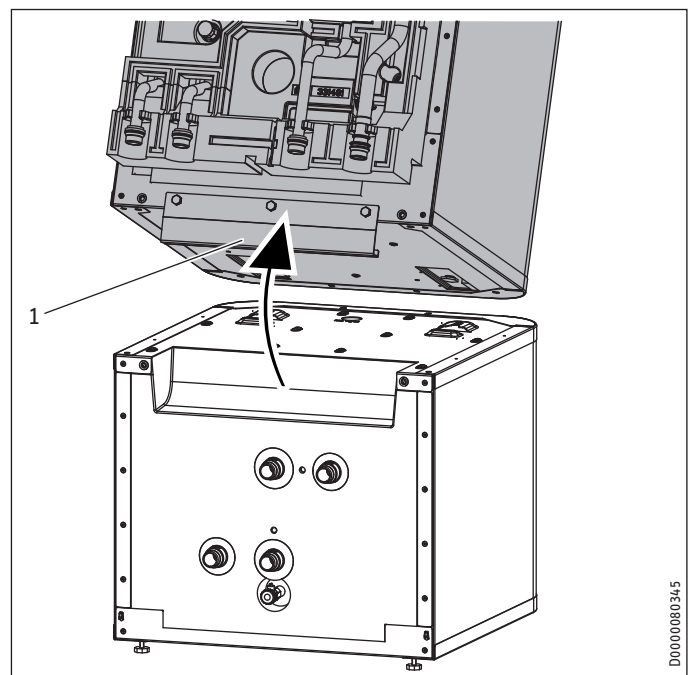

- 1 Handle
- ▶ Tip the upper section of the appliance backwards. Use the handle for improved grip.

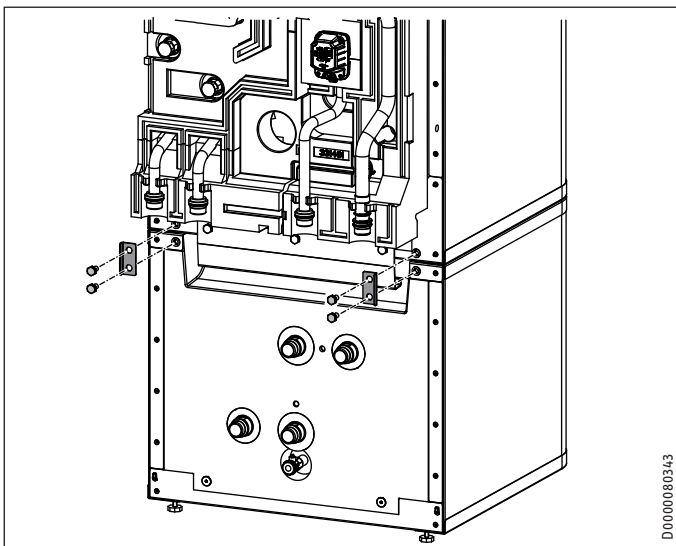

- ▶ Release the 4 screws on the tabs at the front of the appliance.

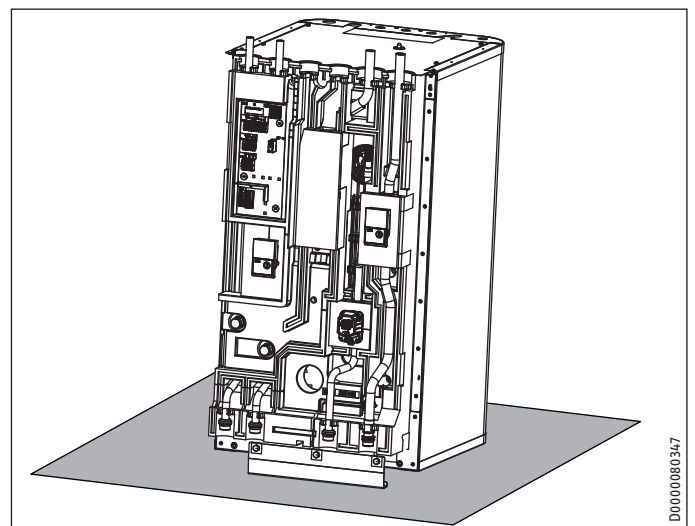

- ▶ Place the upper section of the appliance on a base to prevent damage.

INSTALLATION

Preparation

Joining appliance sections



Material losses

To prevent condensation forming, the insulation segments must fit closely against the lower section with no gaps.

- ▶ When inserting the insulation segments, ensure that the joint grooves are kept clear
- ▶ Tap the insulation segments down with your hand.

Rejoin the appliance sections in reverse order.

The positioning aids and the dotted line marking provide assistance when positioning and inserting the upper appliance section into the guide groove on the lower section:

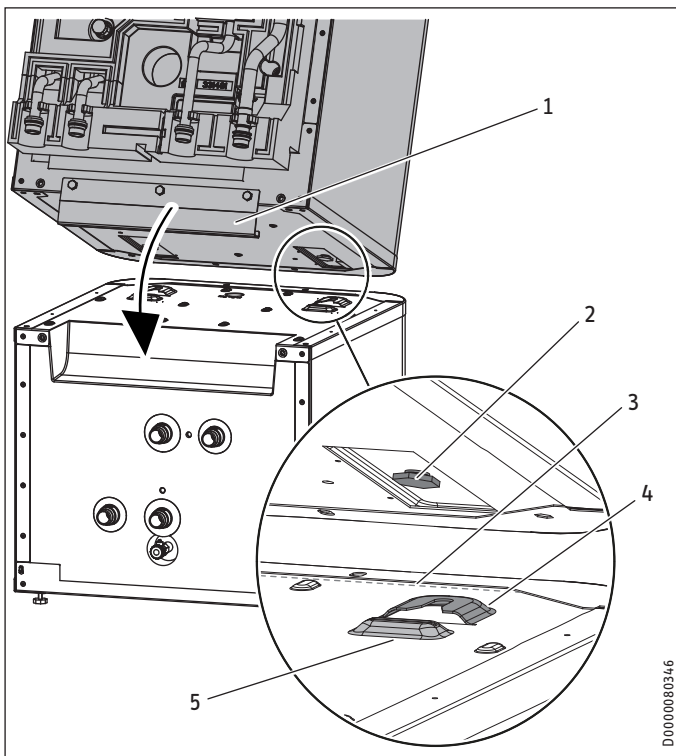

- 1 Handle
- 2 Guide pin
- 3 Dotted line (perforation in the panel)
- 4 Guide groove
- 5 Positioning aid

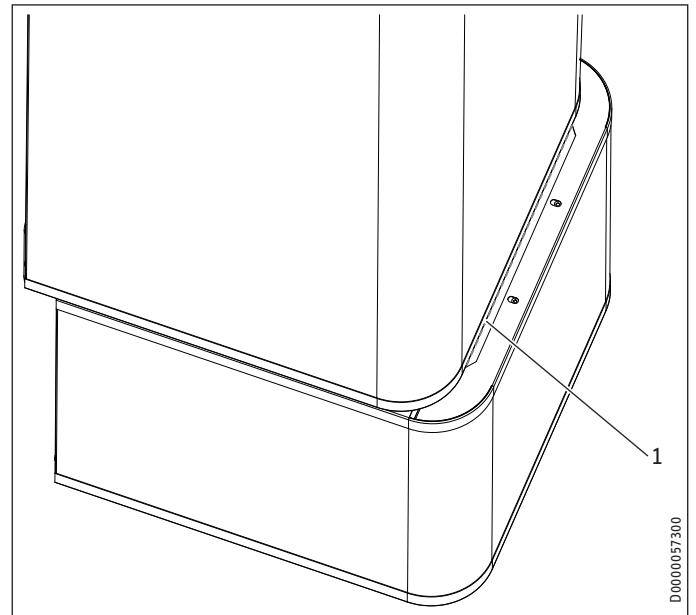

- 1 Dotted line (perforation in the panel)

- ▶ Place the upper appliance section onto the lower appliance section along the dotted line.

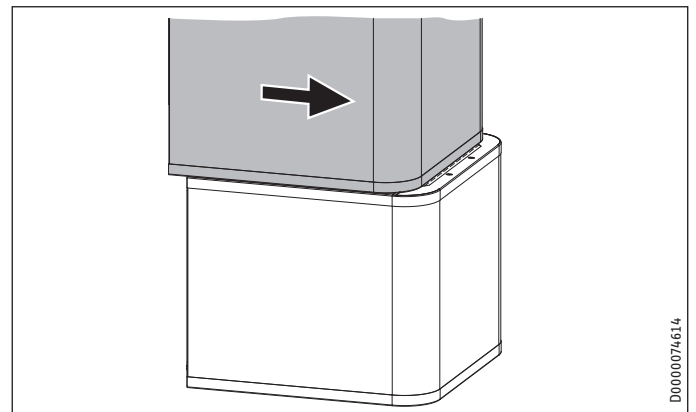

- ▶ Slide the upper appliance section to the back until it is flush with the lower appliance section. If the appliance sections are joined correctly, the final position is determined by the guide groove and guide pin.
- ▶ Secure the tabs on the appliance front.
- ▶ Fit the side profile strips.
- ▶ Fit insulation segment 3 and the 4 hydraulic hoses.
- ▶ Connect the push-fit connectors of the 4 hydraulic connections. Ensure that the spring clips click into place.
- ▶ Insert the "heating sensor" into the buffer cylinder.
- ▶ Lay the sensor lead in the guide groove provided for this purpose.
- ▶ Fit insulation segment 2.
- ▶ Fit insulation segment 1.
- ▶ Fit the front casing.

10. Installation

10.1 Positioning the appliance

- ▶ When positioning the appliance, observe minimum clearances (see chapter "Preparations / Installation site").
- ▶ Use the adjustable feet to compensate for any unevenness in the floor.

10.2 Heating water connection and safety valve

10.2.1 Safety instructions

 **Material losses**
The heating system to which the appliance is connected must be installed by a qualified contractor in accordance with the water installation drawings in the technical guides.

 **Material losses**
When fitting additional shut-off valves, install a further safety valve in an accessible location on the heat generator itself or in the flow line in close proximity to the heat generator.
There must be no shut-off valve between the heat generator and the safety valve.

Oxygen diffusion

 **Material losses**
Avoid open vented heating systems and underfloor heating systems with plastic pipes that are permeable to oxygen.

In underfloor heating systems with plastic pipes that are permeable to oxygen and in open vented heating systems, oxygen diffusion may lead to corrosion on the steel components of the heating system (e.g. on the indirect coil of the DHW cylinder, on buffer cylinders, steel radiators or steel pipes).

 **Material losses**
The products of corrosion (e.g. rusty sludge) can settle in the heating system components, which may result in a lower output or fault shutdowns due to reduced cross-sections.

Supply lines

- ▶ The maximum permissible line length between the appliance and the heat pump will vary, depending on the version of the heating system (pressure drop). As a standard value, assume a maximum line length of 10 m and a pipe diameter of 22-28 mm.
- ▶ Insulate the flow and return lines in accordance with regional regulations.
- ▶ Connect the hydraulic connections with flat gaskets.

Pressure hoses against structure-borne sound transmission:

The appliance and the heat pump are connected to each other hydraulically via pipes carrying heating water. To reduce the transmission of structure-borne sound on the water side, connect the appliance to the heat pump with pressure hoses if these are not already installed in the heat pump.

Pressure differential:

If the available external pressure difference is exceeded, the pressure drop in the heating system could result in a reduced heating output.

- ▶ When sizing the pipes, ensure that the available external pressure differential is not exceeded (see chapter "Specification / Data table").
- ▶ When calculating the pressure drop, take account of the flow and return lines and the pressure drop of the heat pump. The pressure drop must be covered by the available pressure differential.

INSTALLATION

Installation

10.2.2 Fitting the pump assembly (accessory) if required



WARNING Electrocutation
Before starting work on the appliance, disconnect all poles from the power supply and drain the heating circuit via the drain valve on the buffer cylinder.

To extend the appliance with a heating circuit with mixer, you can install pump assembly HSBC 3-HKM (available as an accessory).

Standard delivery HSBC 3-HKM

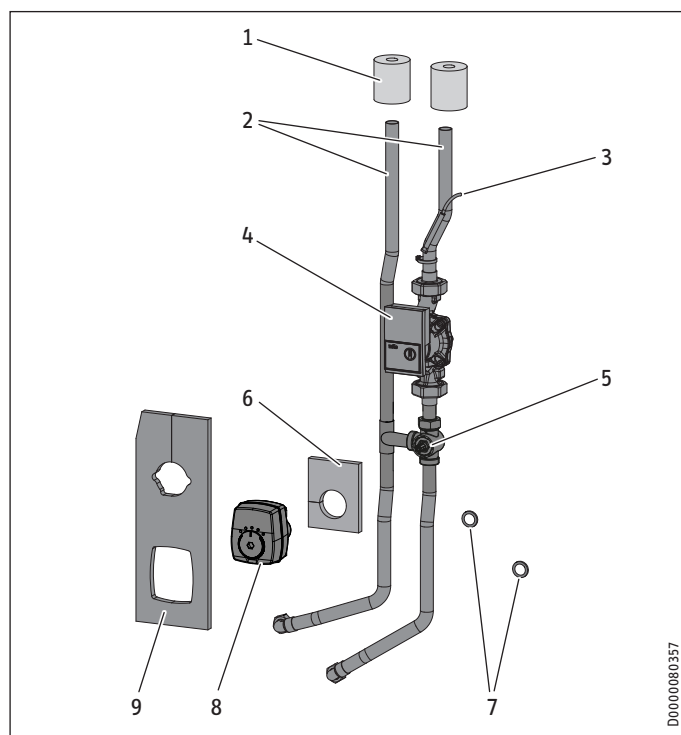

- 1 Pipe insulation
 - 2 Connection pipes (*)
 - 3 Temperature sensor
 - 4 Heating circuit pump (*)
 - 5 3-way mixer (*)
 - 6 Insulation mat for 3-way mixer
 - 7 Flat gaskets
 - 8 Servomotor for 3-way mixer (*)
 - 9 Insulation mat for 3-way mixer and heating circuit pump
- (*)Pipe assembly

Preparation for installation of HSBC 3-HKM

- ▶ Remove the front casing and insulation segment 1 (see chapter "Installation / Preparations / Transport and handling").

The following components are prefitted on the HSBC side at the pump assembly installation site:

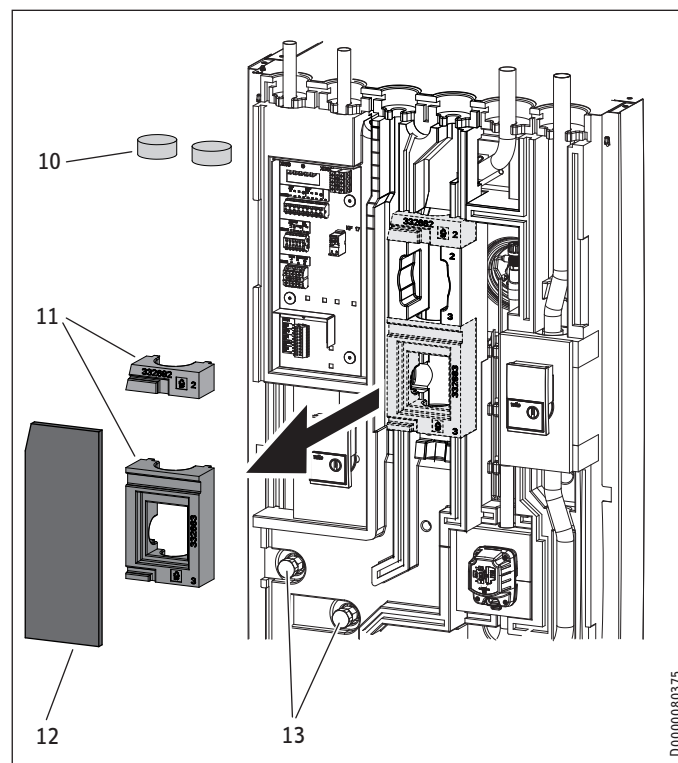

- 10 Insulation plugs
- 11 Profiles for 3-way mixer
- 12 Insulation mat, closed
- 13 Adaptor with dummy cap screwed on

- ▶ Remove the insulation plugs.
- ▶ Remove the closed insulation mat and profiles for the 3-way mixer and the heating circuit pump.
- ▶ Counterhold and unscrew the dummy caps from the adaptors.

INSTALLATION

Installation

HSBC 3-HKM installation

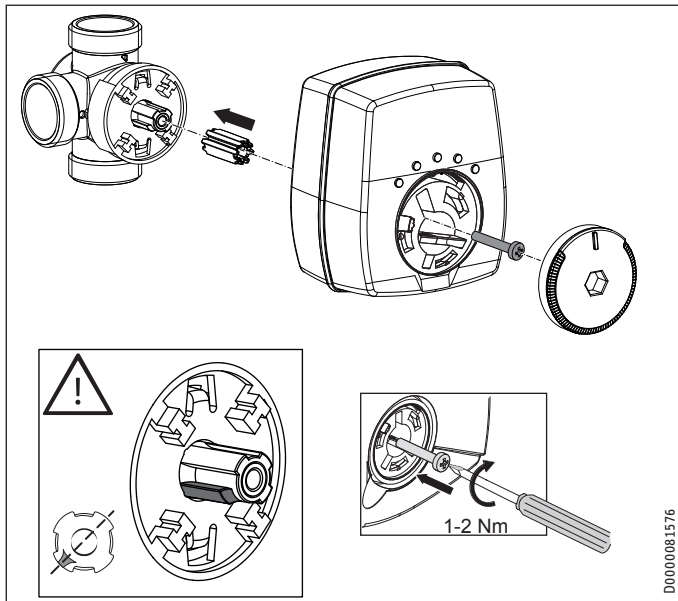

- ▶ Check the position of the 3-way mixer shaft. Adjust the position if necessary.

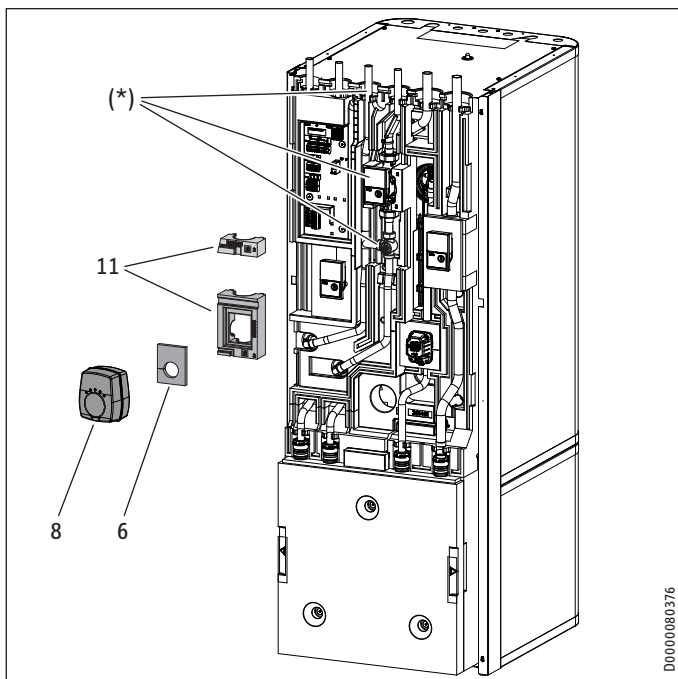

- (*) Pipe assembly inserted
- 6 Insulation mat for 3-way mixer
 - 8 Servomotor for 3-way mixer
 - 11 Profiles for 3-way mixer

- ▶ Insert the pipe assembly.
- ▶ Insert the flat gaskets into the union nuts for the connection pipes.
- ▶ Counterhold and secure the union nuts to the adaptors.
- ▶ Check the alignment of the pipes and functional elements of the pump assembly. Retighten all fittings.
- ▶ Install the profiles for the 3-way mixer over the mixing valve body and above the pump.
- ▶ Place the insulation mat for the 3-way mixer on the valve body.
- ▶ Install the servomotor for the 3-way mixer

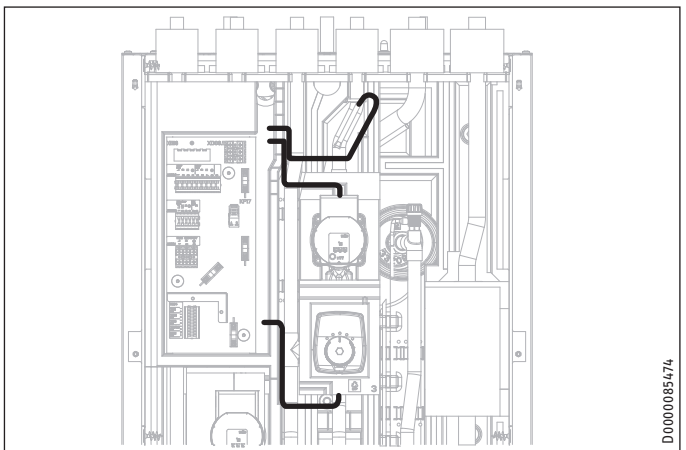

Material losses

To prevent condensation from forming, do not lay any cables in the joint grooves of the EPP parts.

- ▶ Route the pump assembly connecting cable to the control panel as shown.
- ▶ Slide the pipe insulation over the connection pipe connectors from above.

INSTALLATION

Installation

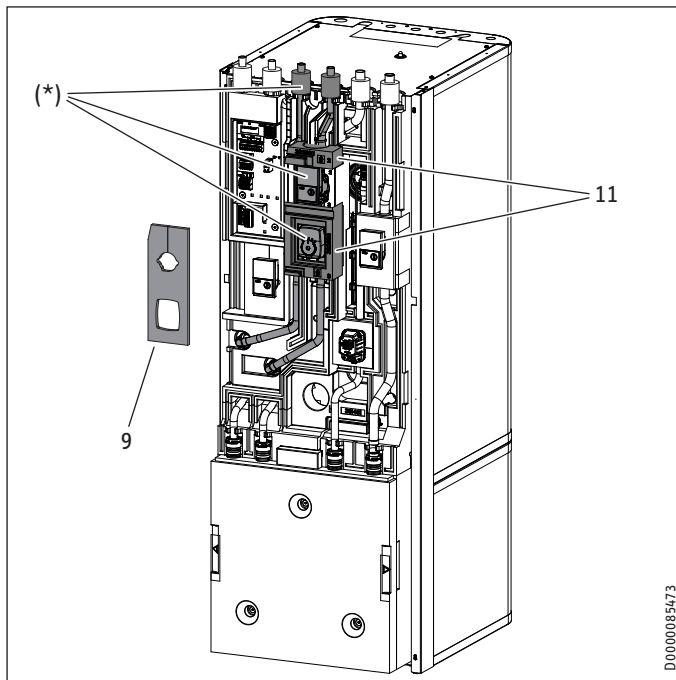

- (*) Pipe assembly inserted
 9 Insulation mat for 3-way mixer and heating circuit pump
 11 Profiles for 3-way mixer
- ▶ Insert the insulation mat on the HKM side for the 3-way mixer and the heating circuit pump.

Electrical connection HSBC 3-HKM

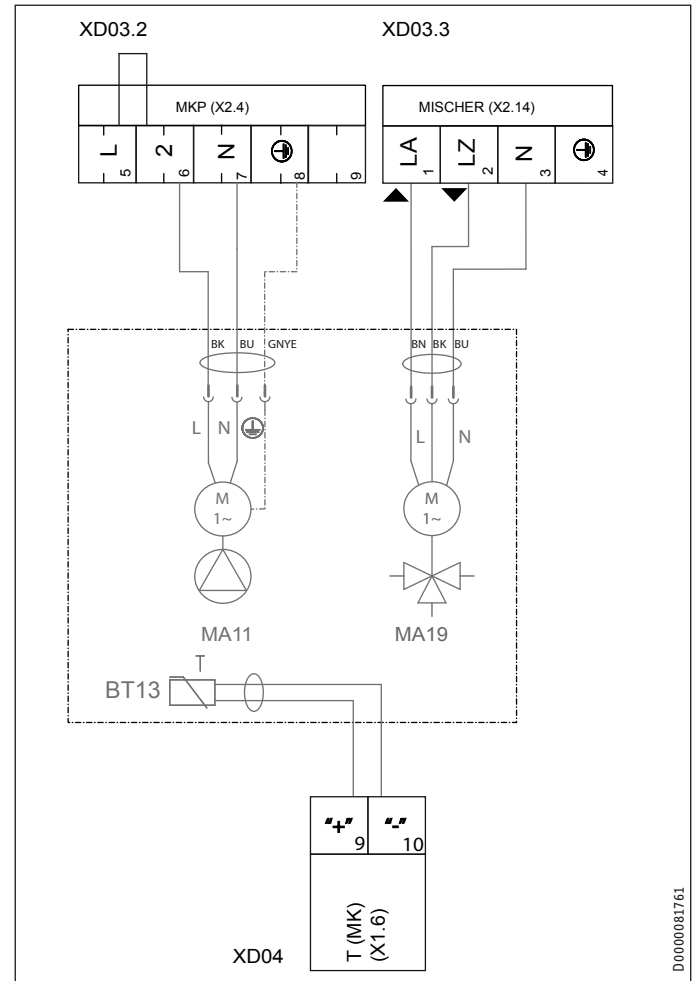

- ▶ Wire up the heating circuit pump and 3-way mixer (see chapter "Installation / Electrical connection / Control voltage").

INSTALLATION

Installation

10.2.3 If necessary, install an HSBC 3-HE auxiliary heating element as an accessory



WARNING Electrocutation

Before starting work on the appliance, disconnect all poles from the power supply and drain the DHW cylinder.

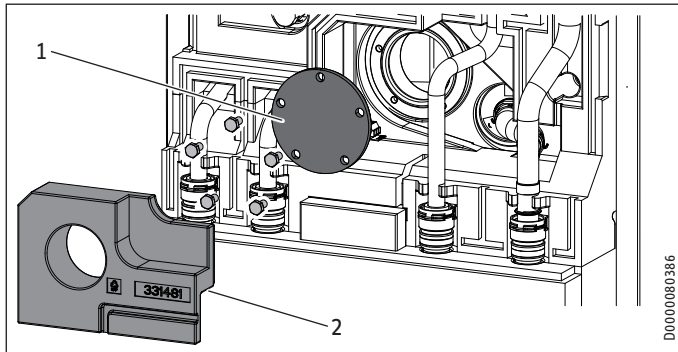

1 Blank flange

2 Insulation segment

- ▶ Remove the insulation segment in front of the flange plate.
- ▶ Remove the blank flange.

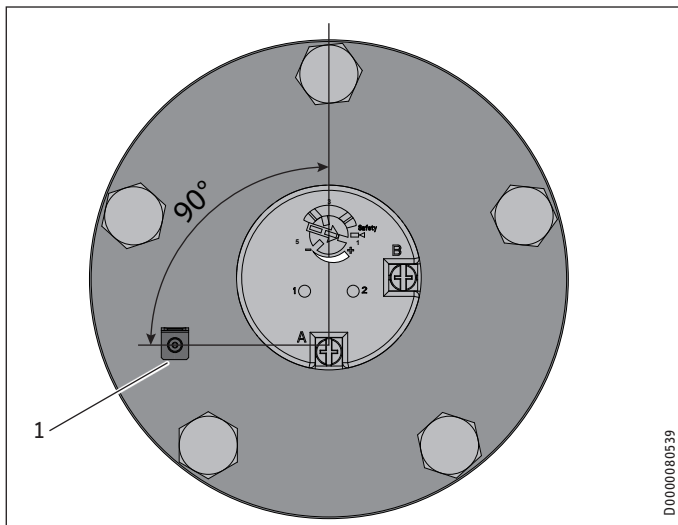

1 Earthing contact PE

- ▶ Move the auxiliary heating element into the correct installation position. Use the position of the earthing contact as a guide.

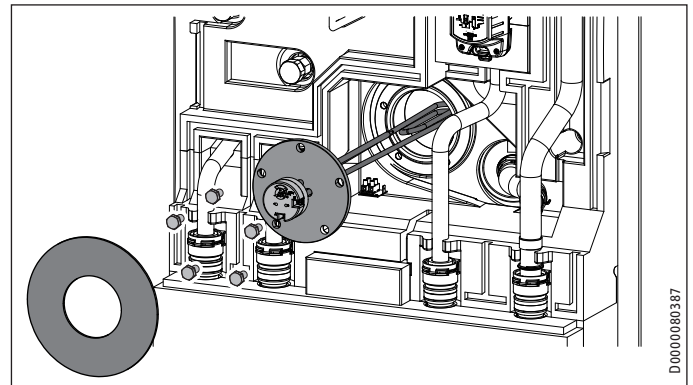

- ▶ Place the insulation mat (included in the standard delivery for the auxiliary heating element) on the thermostat.
- ▶ Insert the insulation mat between the flange plate and cable.
- ▶ Install the auxiliary heating element. Observe the tightening torque (see chapter "Installation / Specification / Accessories").

Electrical connection HSBC 3-HE

In the delivered condition, the 3 wires for connecting the auxiliary heating element are connected to a prefitted terminal and earthing tab.

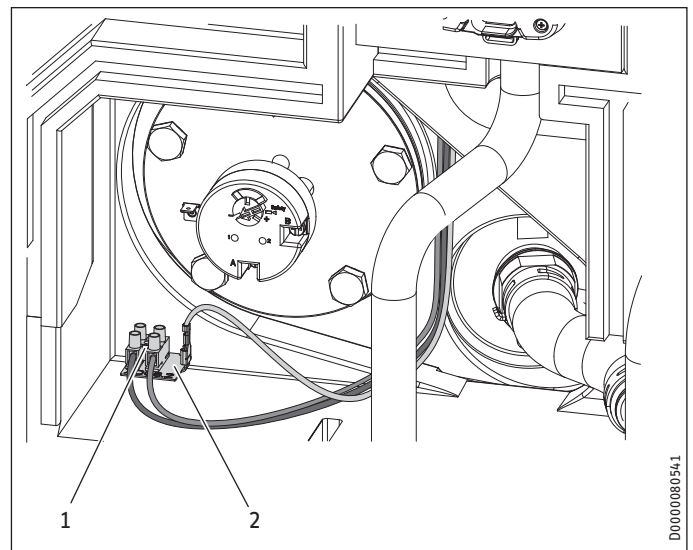

1 Terminal

2 Earthing tab

- ▶ Disconnect the 3 wires from the terminal and the earthing tab.
- ▶ Remove the terminal and earthing tab.

INSTALLATION

Installation

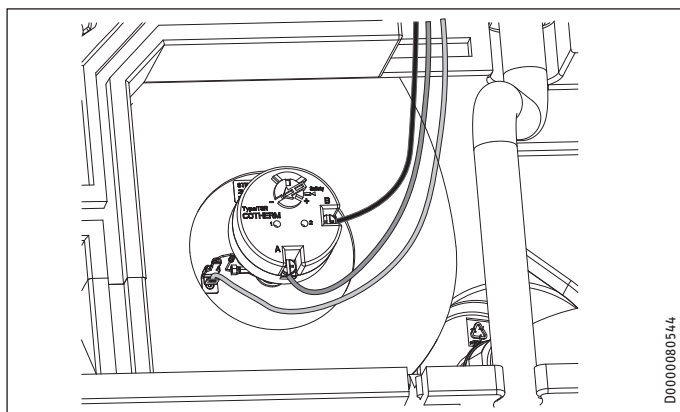

► Connect the 3 wires to the auxiliary heating element as shown.

A	BK / BN
B	BU
PE	GNYE



Note

The auxiliary heating element standard delivery includes two identical wiring diagram labels for covering "HSBC 3-HE (accessory X2.11)" on the wiring diagram:

- On the back of the front casing
 - In these instructions (see chapter "Installation / Specification / Wiring diagram")
- After installation of the auxiliary heating element, affix the wiring diagram labels in the corresponding places.

► Wire up the auxiliary heating element (see chapter "Installation / Electrical connection / Auxiliary heating element").

Setting HSBC 3-HE

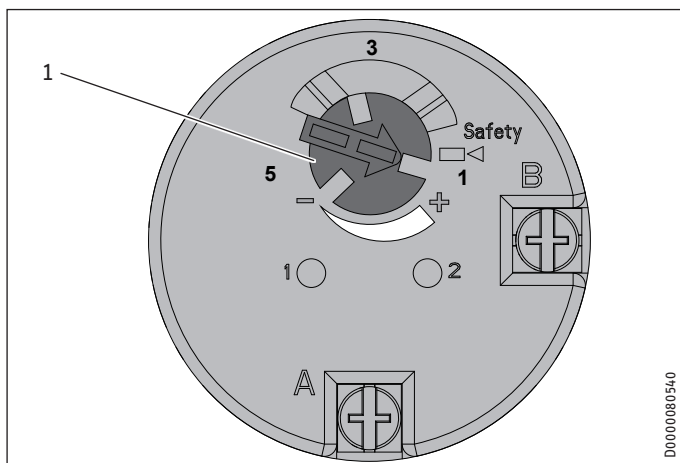

1 Temperature selector for the auxiliary heating element

► Turn the temperature selector anti-clockwise as far as it will go to set the maximum temperature (65 ± 5 °C).

INSTALLATION

Installation

10.2.4 Hydraulic connection



Note

► Observe the details specified in the chapter "Installation / Specification / Hydraulic diagrams".

- Thoroughly flush the pipes before connecting the heat pump. Foreign bodies (e.g. welding pearls, rust, sand, sealant, etc.) can impair the operational reliability of the heat pump.
- Install the heating water pipes (see chapter "Specification / Dimensions and connections").

10.3 DHW connection and safety assembly

10.3.1 Safety instructions



Material losses

The maximum permissible pressure must not be exceeded (see chapter "Specification / Data table").



Material losses

Operate the appliance only with pressure-tested taps.

Cold water line

Galvanised steel, stainless steel, copper and plastic are approved materials.



Material losses

A safety valve is required.

DHW line, DHW circulation line

Stainless steel, copper and plastic are approved materials.

10.3.2 Installing the pipe assembly (accessory) if required



WARNING Electrocutation

Before starting work on the appliance, disconnect all poles from the power supply and drain the DHW cylinder.



Note

The following diagrams show pipe assembly RBS-SBC (see chapter "Specification / Dimensions and connections").

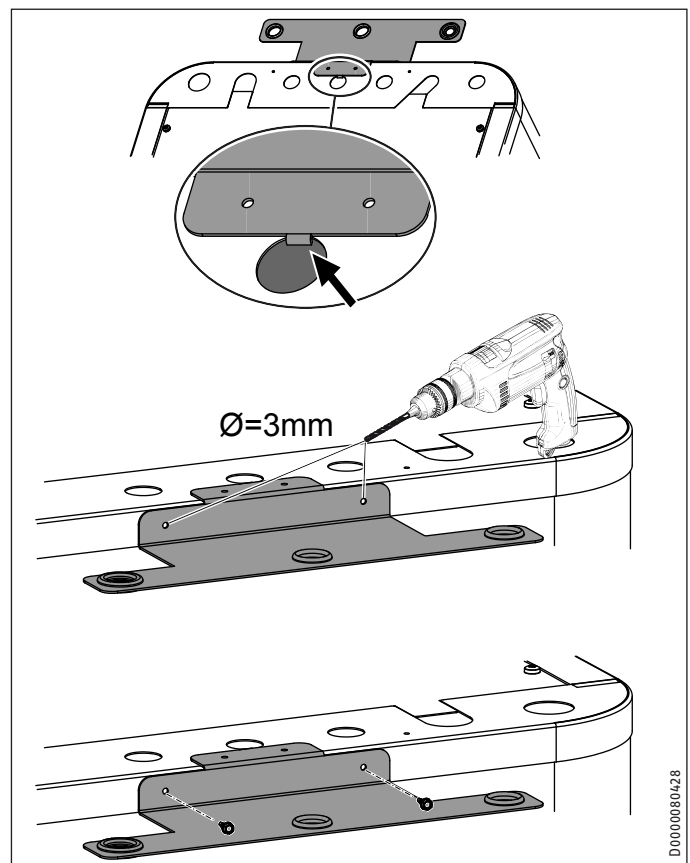

- Hook the retainer for the connection pipes into the top centre of the appliance.
- Use the retainer as a drilling template and pre-drill the fixing holes.
- Secure the retainer with the screws.

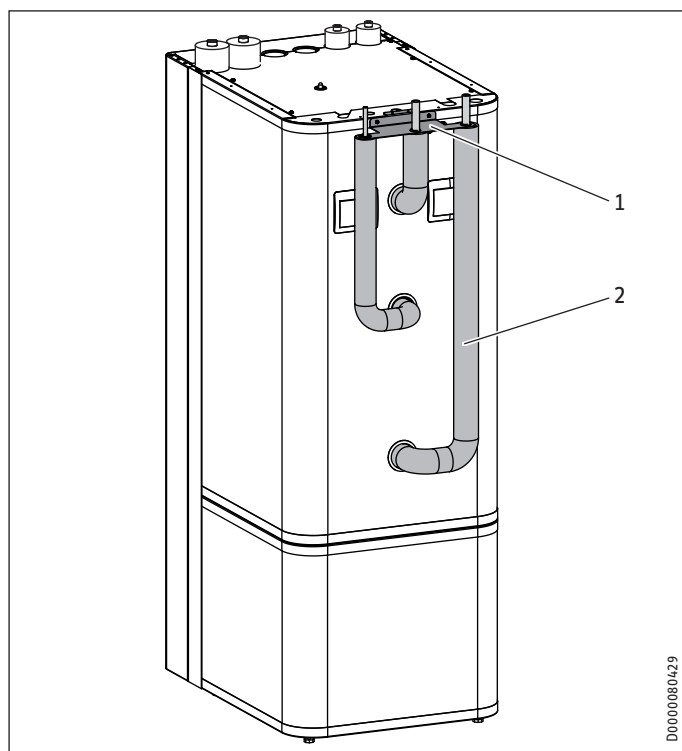

- 1 Retainer
- 2 Insulated connection pipes

- ▶ Install the connection pipes in sequence, starting on the left or right depending on the positioning of the appliance.
- ▶ Insert the connection pipes through the retainer from below.
- ▶ Secure the connections to the appliance using the union nuts.
- ▶ Connect the pipes of the pipe assembly to the domestic pipe-work system.

10.3.3 Installing the DHW circulation line, if applicable

A DHW circulation line with external DHW circulation pump can be fitted to the DHW circulation connection (see chapter "Specification / Dimensions and connections").

- ▶ Remove the sealing cap from the DHW circulation connection (see chapter "Specification / Dimensions and connections").
- ▶ Connect the DHW circulation line.

10.3.4 DHW connection and safety assembly

- ▶ Flush the pipes thoroughly.
- ▶ Install the DHW outlet line and the cold water inlet line (see chapter "Specification / Dimensions and connections"). Connect the hydraulic connections with flat gaskets.
- ▶ Install a type-tested safety valve in the cold water inlet line. Please note that, depending on the supply pressure, you may also need a pressure reducing valve.
- ▶ Size the drain pipe so that water can drain off unimpeded when the safety valve is fully opened.
- ▶ The safety valve drain aperture must remain open to atmosphere.
- ▶ Install the safety valve drain pipe with a constant fall to the drain.

10.4 Filling the system

Heating circuit water quality

Carry out a fill water analysis before filling the system. This analysis may, for example, be requested from the relevant water supply utility.

To avoid damage as a result of scaling, it may be necessary to soften or desalinate the fill water. The fill water limits specified in chapter "Specification / Data table" must always be observed.

- ▶ Recheck these limits 8-12 weeks after commissioning and during the annual system service.



Note

With a conductivity >1000 µS/cm, desalination treatment is recommended in order to avoid corrosion.



Note

If you treat the fill water with inhibitors or additives, the same limits apply as for desalination.



Note

Suitable appliances for water softening, as well as for filling and flushing heating systems, can be obtained via trade suppliers.



Material losses

Never switch on the power before filling the system.

10.4.1 Filling the heating system

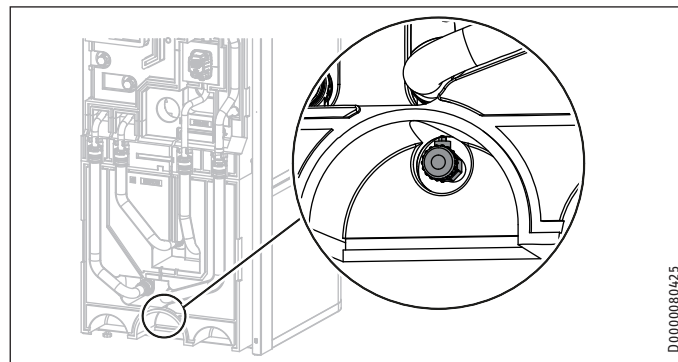

- ▶ Fill the heating system via the drain valve.
- ▶ Vent the pipework.

10.4.2 DHW cylinder filling

- ▶ Filling the DHW cylinder via the "cold water inlet" connection.
- ▶ Open all downstream draw-off valves until the appliance is full and the pipework is free of air.
- ▶ Adjust the flow rate. For this, observe the maximum permissible flow rate with a fully opened tap (see chapter "Specification / Data table"). If necessary reduce the flow rate at the butterfly valve of the safety assembly.
- ▶ Carry out a tightness check.
- ▶ Check the safety valve.

10.5 Venting the appliance

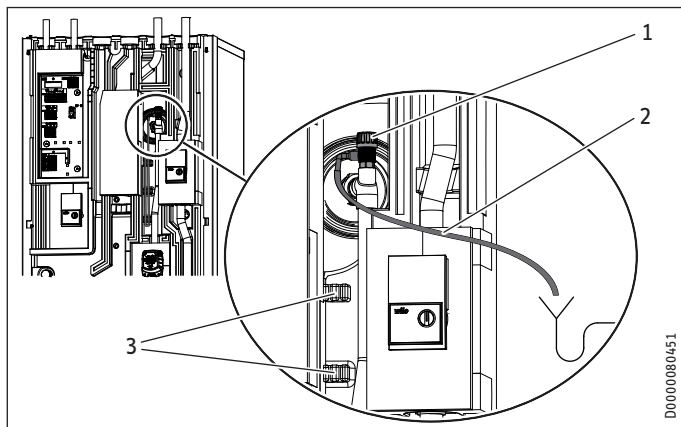

- 1 Air vent valve
- 2 Vent hose
- 3 Hose attachment

- ▶ Detach the vent hose from the hose attachment.
- ▶ Hang the free end of the vent hose in a container.
- ▶ To ventilate, open the air vent valve.
- ▶ After ventilation, close the air vent valve.
- ▶ Secure the vent hose.

11. Electrical connection



WARNING Electrocutation

Carry out all electrical connection and installation work in accordance with relevant regulations. Before any work on the appliance, disconnect all poles from the power supply.



WARNING Electrocutation

The connection to the power supply must be in the form of a permanent connection. Ensure the appliance can be separated from the power supply by an isolator that disconnects all poles with at least 3 mm contact separation. This requirement can be met by using contactors, circuit breakers, fuses/MCBs, etc.



Material losses

Provide separate fuses for the two power circuits of the appliance and the control unit.



Material losses

Observe the type plate. The specified voltage must match the mains voltage.



Note

Leakage currents of up to 5 mA may occur.



Note

You must have permission to connect the appliance from the relevant power supply utility.

The terminal box of the appliance is located behind the front casing (see chapter "Preparations / Transport and handling / Removing / Fitting the front casing").

INSTALLATION

Electrical connection

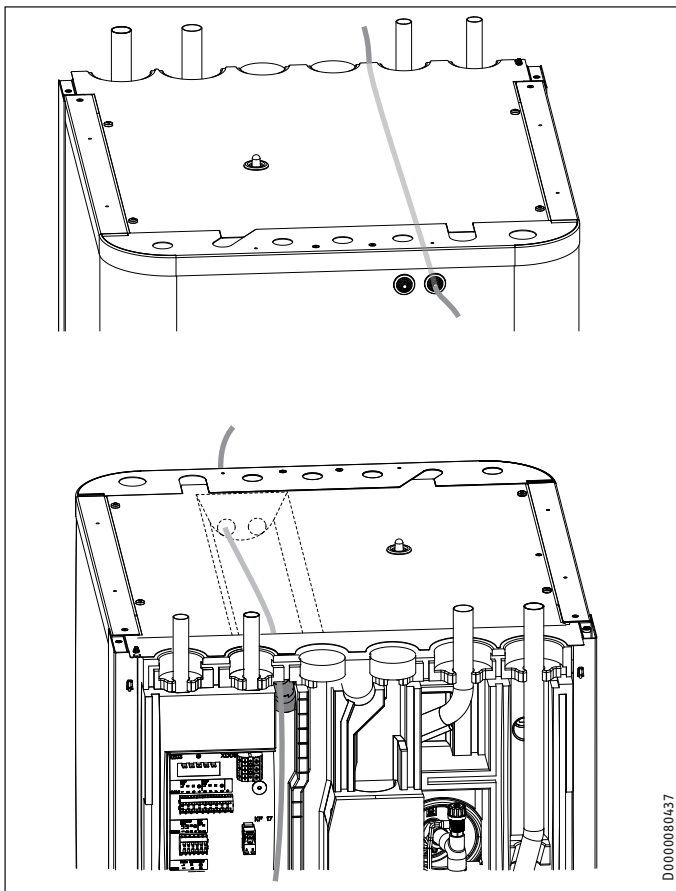

D0000080437

- ▶ Route all power cables and sensor leads into the appliance through the cable entry.
- ▶ Connect the power cables and sensor leads as detailed below.

Install cables with the following cross-sections in accordance with the respective fuse protection:

Fuse protection	Assignment	Cable cross-section
B 16 A	Control	1.5 mm ²

11.1 Control voltage



Material losses

- ▶ Only connect energy efficient circulation pumps approved by us to the pump connections.

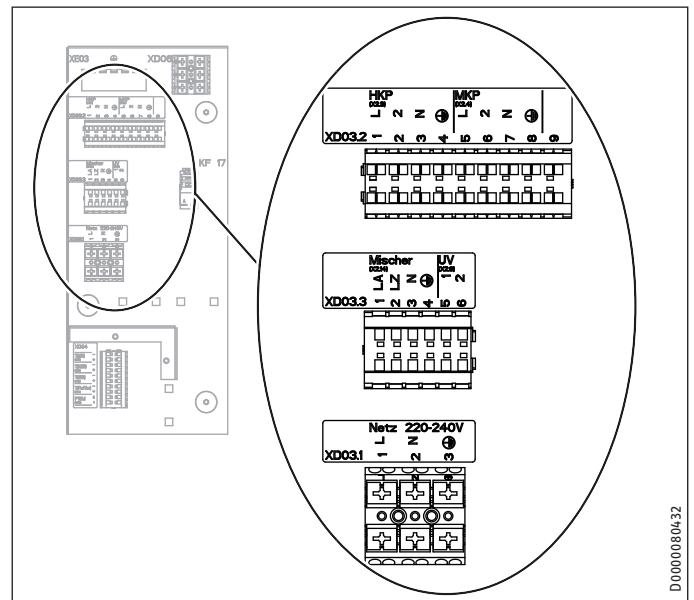

D0000080432

- XD03.1 Control terminal
- XD03.2 Control terminal
- XD03.3 Control terminal
- XE03 Earth terminal, control unit

- XD03.1 Control terminal
Power supply Mains buffer charging pump
220-240 V

- XD03.2 Control terminal
HKP Heating circuit pump
MKP Mixer circuit pump, heating circuit 2



Note

At terminals XD03.2 HKP/MKP, you can install a temperature limiter for the underfloor heating system by removing the jumper between L and 2.

- XD03.3 Control terminal
Mixer Mixer, servomotor, heating circuit 2
UV Diverter valve, heating/DHW

ENGLISH

INSTALLATION

Electrical connection

11.2 Safety extra low voltage

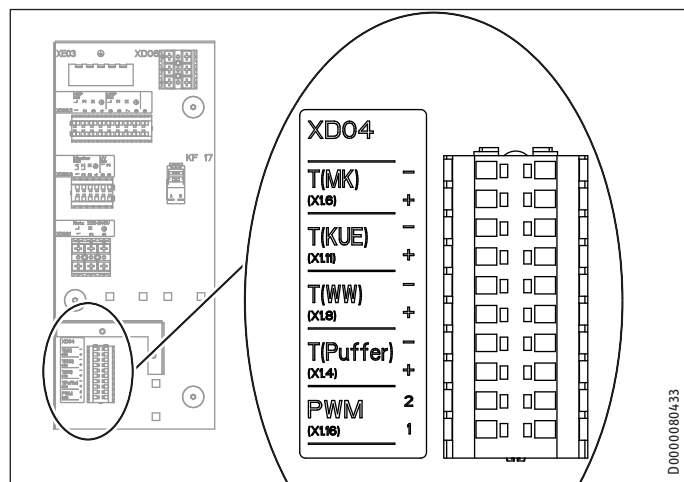

XDO4 Terminal, safety extra low voltage	
T(MK)	Mixer circuit temperature sensor for HSBC 3-HKM (optional)
T(KUE)	Temperature sensor for area cooling (optional)
T(WW)	DHW temperature sensor
T(Puffer)	Temperature sensor, buffer cylinder
PWM	Control by WPM

Control by WPM via PWM signal

- Observe the information in the operating and installation instructions of the WPM heat pump manager.

11.3 Power supply for auxiliary heating element

Note The "Heater terminal" (XD06.1) can only be assigned when the optional HSBC 3-HE auxiliary heating element is installed.

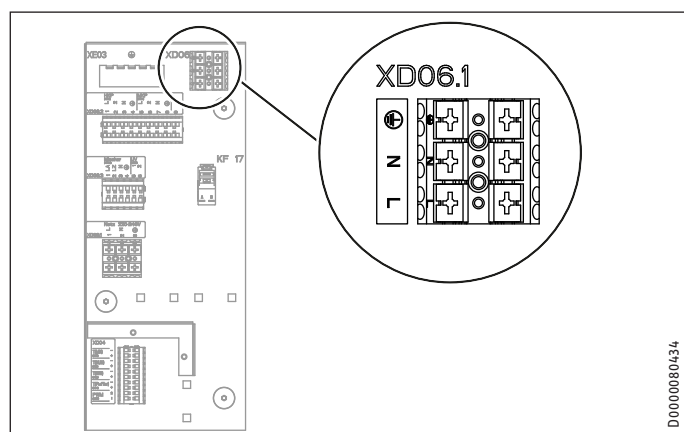

XD06.1 Heater terminal (accessories HSBC 3-HE)

11.4 Sensor installation

Note The temperature sensor needs to be replaced on combined appliance system HSBC 300 L cool with WPF / WPF cool.
► Use the PTC temperature sensor that was included in the standard delivery of the heat pump.

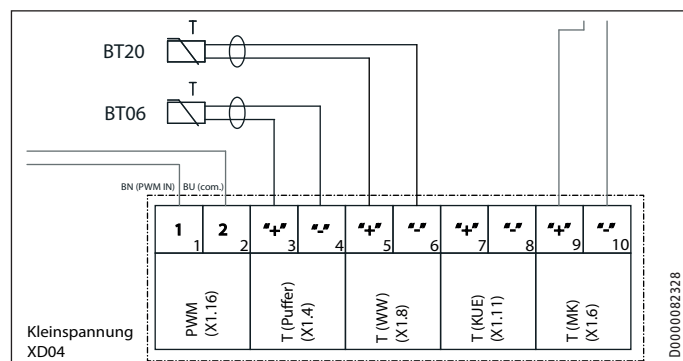
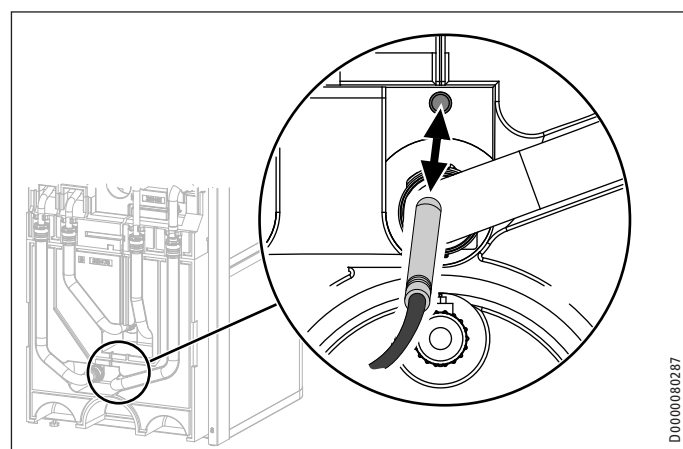
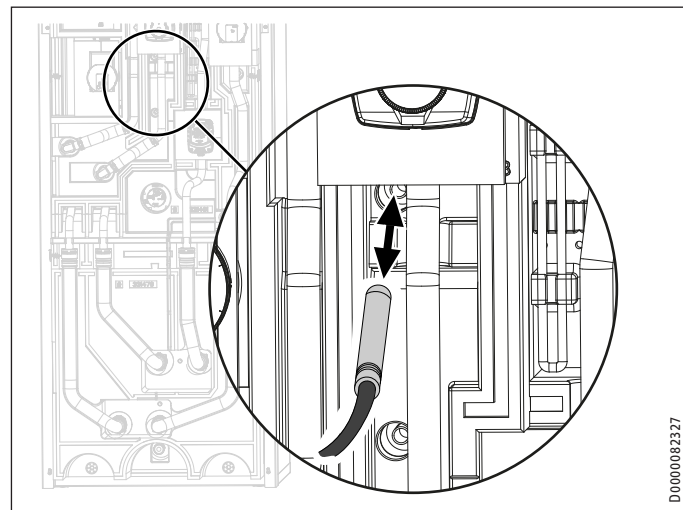

Appliances concerned:

- 238826 HSBC 300 L cool
- 232909 - 232912 WPF 04 - WPF 10
- 232915 - 232918 WPF 04 cool - WPF 10 cool

11.4.1 Temperature sensor for cooling (accessory), if required

Cooling requires the fitting of a temperature sensor, available as an accessory.

- ▶ Remove the front casing (see chapter "Preparations / Transport and handling / Removing / fitting the front casing").

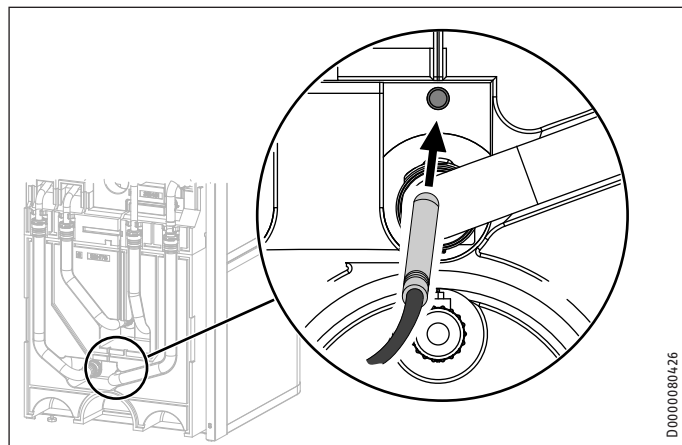

- ▶ Insert the temperature sensor into the sensor well "Sensor heat pump cooling, optional".

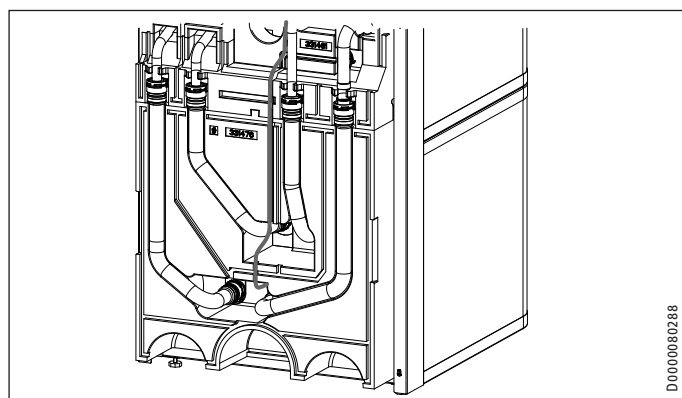

- ▶ Lay the sensor lead in the guide groove provided for this purpose in the insulation segment.
- ▶ Connect the temperature sensor to T(KUE) of terminal XD04 of the appliance.

INSTALLATION

Commissioning

12. Commissioning

Our customer support can assist with commissioning, which is a chargeable service.

If the appliance is intended for commercial use, observe the rules of the relevant Health & Safety at Work Act during commissioning. For further details, check with your local authorising body (in Germany, for example, this is the TÜV).

12.1 Wilo-Para .../Sc circulation pumps

LED indicators

	Operation indicator: LED illuminates green in normal operation LED illuminates/flashes when there is a fault
	Display of selected control mode Δp -v, Δp -c and constant speed
	Display of selected curve (I, II, III) within the control mode
	Combinations of LED displays for venting function, manual re-start and key lock

Operating button

	<p>Press</p> <ul style="list-style-type: none"> To select control mode To select curve (I, II, III) within the control mode <p>Press and hold</p> <ul style="list-style-type: none"> To activate venting function (press for 3 seconds) For manual restart (press for 5 seconds) To lock/unlock keys (press for 8 seconds)
--	---

Control modes and functions

Variable differential pressure Δp -v (I, II, III) Recommended for two-pipe heating systems with radiators to reduce flow noise at thermostatic valves

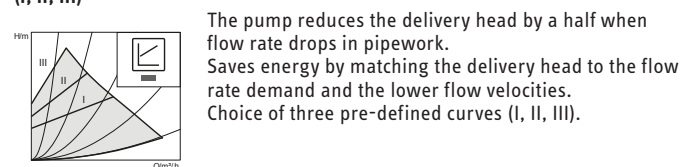

Constant pressure differential Δp -c (I, II, III) Recommended for underfloor heating systems or with large-diameter pipework and for all applications with a non-varying pipework curve (e.g. cylinder charging pumps) and single-pipe heating systems with radiators

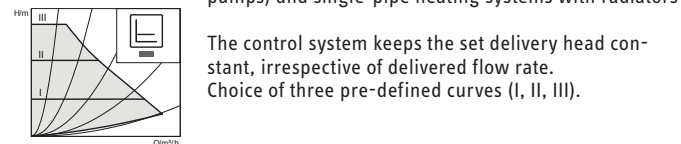

Constant speed (I, II, III) Recommended for systems with unchanging system resistance which require a constant throughput.

The pump runs at three preset fixed speed levels (I, II, III).

Note
Factory setting: Constant speed, curve III

Venting

Fill the system properly and ventilate it
If the pump is not ventilated automatically:
Activate the venting function via the operating button, press button for 3 seconds, then release it.
Venting function starts (duration 10 minutes).
The top and bottom rows of LEDs flash alternately every second.
To cancel, press the operating button for 3 seconds.

Note
After venting, the LED indicator displays the previously set pump values.

Setting control modes

Selecting the control mode
The LEDs for the control modes and associated curves illuminate one after the other.

Briefly press the operating button (for approx. 1 second).
LEDs indicate the current selected control mode and curve (see following table).

Operating button	LED indicator	Control mode	Curve
1x		Constant speed	II
2x		Constant speed	I
3x		Variable differential pressure Δp -v	III
4x		Variable differential pressure Δp -v	II
5x		Variable differential pressure Δp -v	I
6x		Constant differential pressure Δp -c	III
7x		Constant differential pressure Δp -c	II
8x		Constant differential pressure Δp -c	I
*9x		Constant speed	III

(*) Pressing the button for the 9th time in succession returns the system to the factory setting (constant speed, curve III).

Appliance shutdown

12.2 Appliance handover

- ▶ Explain the appliance function to users and familiarise them with how it works.
- ▶ Make users aware of potential dangers.
- ▶ Hand over these instructions.

13. Appliance shutdown



Material losses

Observe the temperature application limits and the minimum circulation volume on the heat consumer side (see chapter "Specification / Data table").



Material losses

Drain the system when there is a risk of frost and the heat pump is completely switched off (see chapter "Maintenance / Draining the DHW cylinder").

- ▶ If you take the system out of use, set the heat pump manager to standby so that the safety functions that protect the appliance (e.g. frost protection) remain active.

14. Maintenance



WARNING Electrocutation

Carry out all electrical connection and installation work in accordance with relevant regulations.



WARNING Electrocutation

Before any work on the appliance, disconnect all poles of the appliance from the power supply.

Draining the buffer cylinder

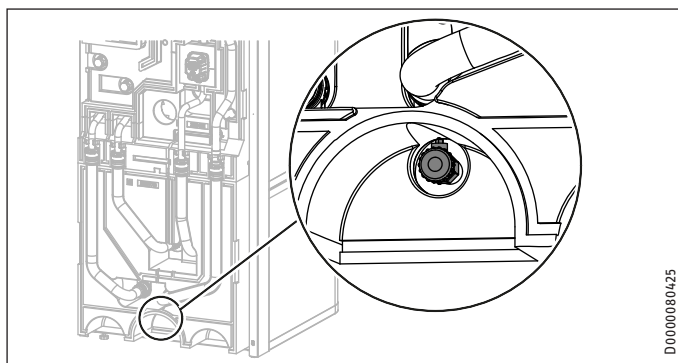

- ▶ Drain the buffer cylinder via the drain valve.

Draining the DHW cylinder



CAUTION Burns

Hot water may escape during draining.

- ▶ Close the shut-off valve in the cold water inlet line.
- ▶ Open the hot water taps on all draw-off points.
- ▶ Empty the DHW cylinder via the "cold water inlet" connection.

Cleaning and descaling the DHW cylinder



Material losses

Never use descaling pumps or descaling agents to clean the cylinder.

- ▶ Clean the appliance through the inspection port.

For the torque of the flange screws, see chapter "Specification / Dimensions and connections".

Replacing the signal anode

- ▶ Replace the signal anode if it becomes depleted.

15. Specification

15.1 Dimensions and connections

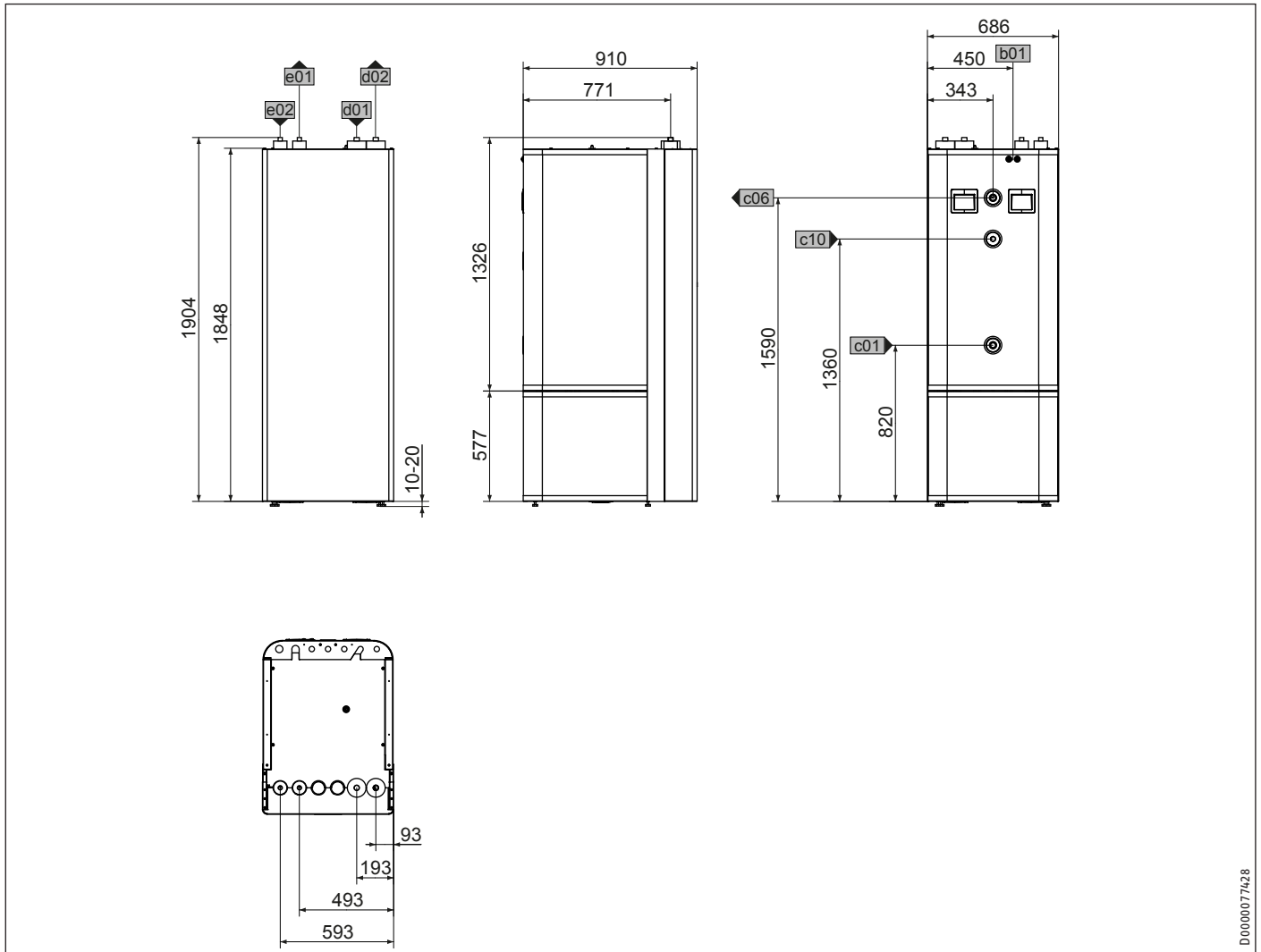

D0000077428

			HSBC 300 cool	HSBC 300 L cool
b01	Entry electrical cables			
c01	Cold water inlet	Male thread	G 1	G 1
c06	DHW outlet	Male thread	G 1	G 1
c10	DHW circulation	Male thread	G 1/2	G 1/2
d01	Heat pump flow	Diameter	mm	28
d02	Heat pump return	Diameter	mm	28
e01	Heating flow	Diameter	mm	22
e02	Heating return	Diameter	mm	22

INSTALLATION Specification

Other dimensions and connections

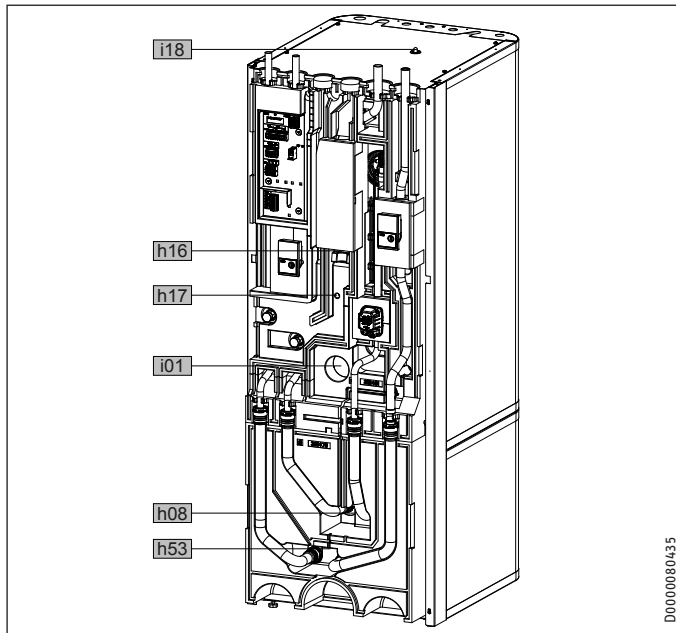

			HSBC 300 cool	HSBC 300 L cool
h08	Sensor heat pump cooling, optional	Diameter	mm 9.5	9.5
h16	Sensor DHW	Diameter	mm 9.5	9.5
h17	Sensor, DHW, optional	Diameter	mm 9.5	9.5
h53	Sensor heating	Diameter	mm 9.5	9.5
i01	Flange	External diameter	mm 140	140
		Torque	Nm 45	45
i18	Protective anode	Female thread	G 1 1/4	G 1 1/4

15.1.1 HSBC 3-HKM accessories

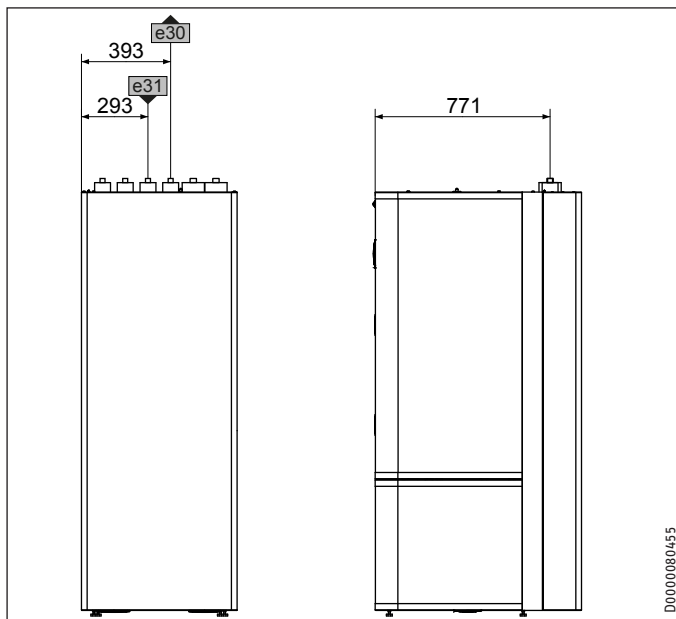

15.1.2 Accessories RBS-SBC

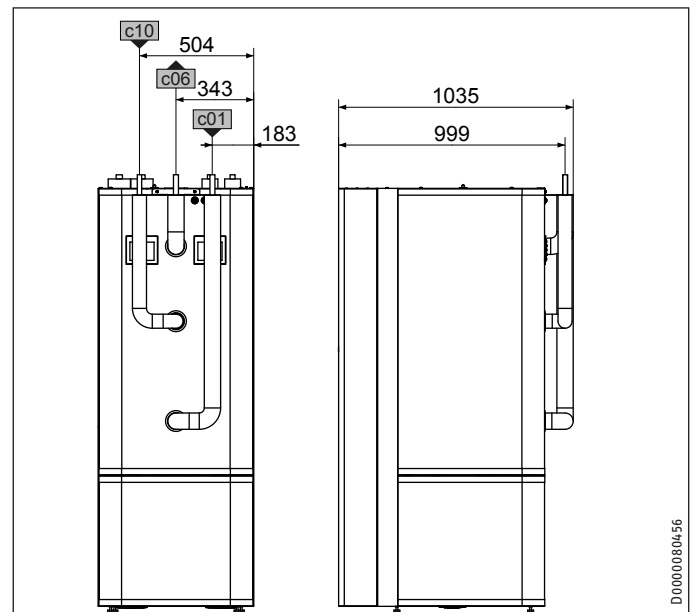

			HSBC 3-HKM	RBS-SBC
c01	Cold water inlet	Diameter	mm 22	22
c06	DHW outlet	Diameter	mm 22	22
c10	DHW circulation	Diameter	mm 12	12
e30	Heating flow, mixed	Diameter	mm 22	22
e31	Heating return, mixed	Diameter	mm 22	22

15.2 Wiring diagram

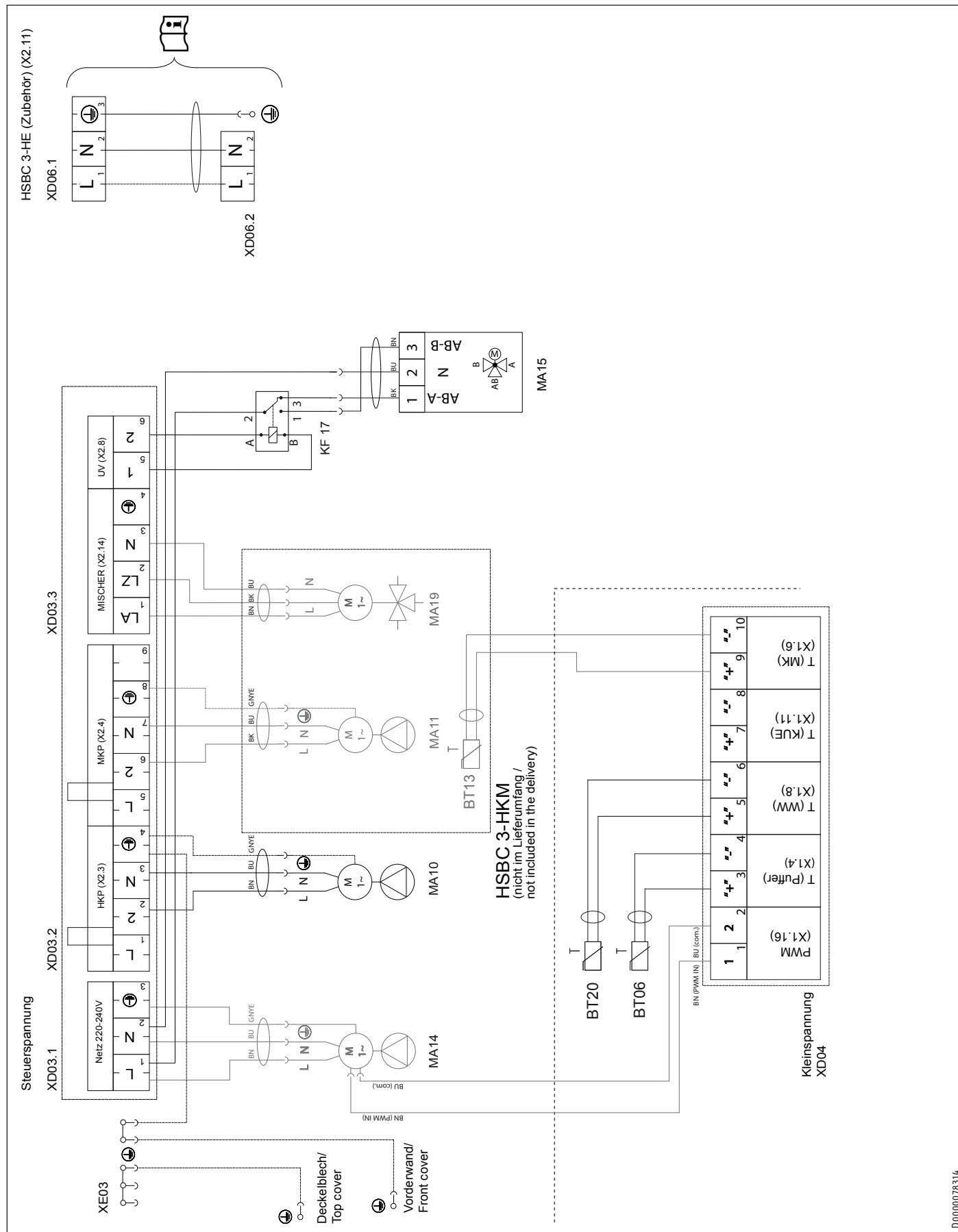

D0000078314

INSTALLATION

Specification

BT06	Temperature sensor, heat pump buffer cylinder
BT20	Temperature sensor, DHW cylinder
BT13	Temperature sensor HP flow HC2 (accessories HSBC 3-HKM)
MA10	Motor, pump, heating circuit
MA11	Motor, pump, heating circuit 2
MA14	Motor, buffer charging pump (not for HSBC 300 L cool and TSBC 300 L plus)
MA15	Motor, diverter valve, heating, DHW
MA19	Motor, mixing valve heating circuit 2
XD04	LV terminal
XD06.1	Heater terminal (accessories HSBC 3-HE)
XD06.2	Heater terminal (accessories HSBC 3-HE)
XD03.1	Control terminal (mains buffer charging pump)
XD03.2	Control terminal (heating circuit pump, pump heating circuit 2)
XD03.3	Control terminal (mixer heating circuit 2, diverter valve)
KF17	Relay, diverter valve, heat source
XE03	Earth terminal, control unit

15.3 Hydraulic diagrams

HSBC 300 cool

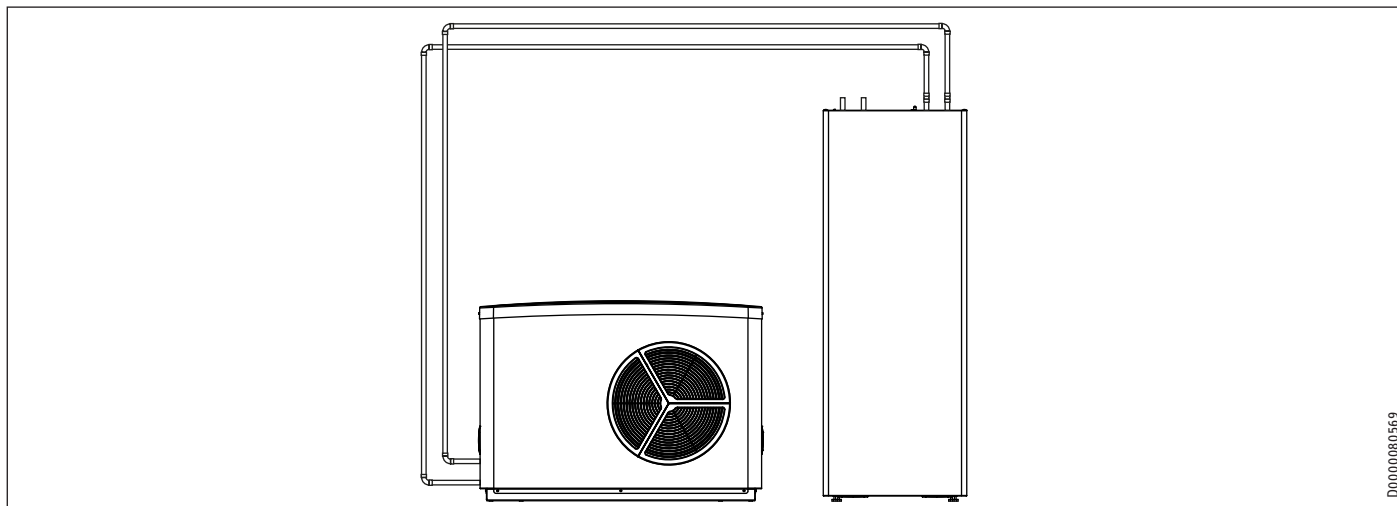

HSBC 300 L cool

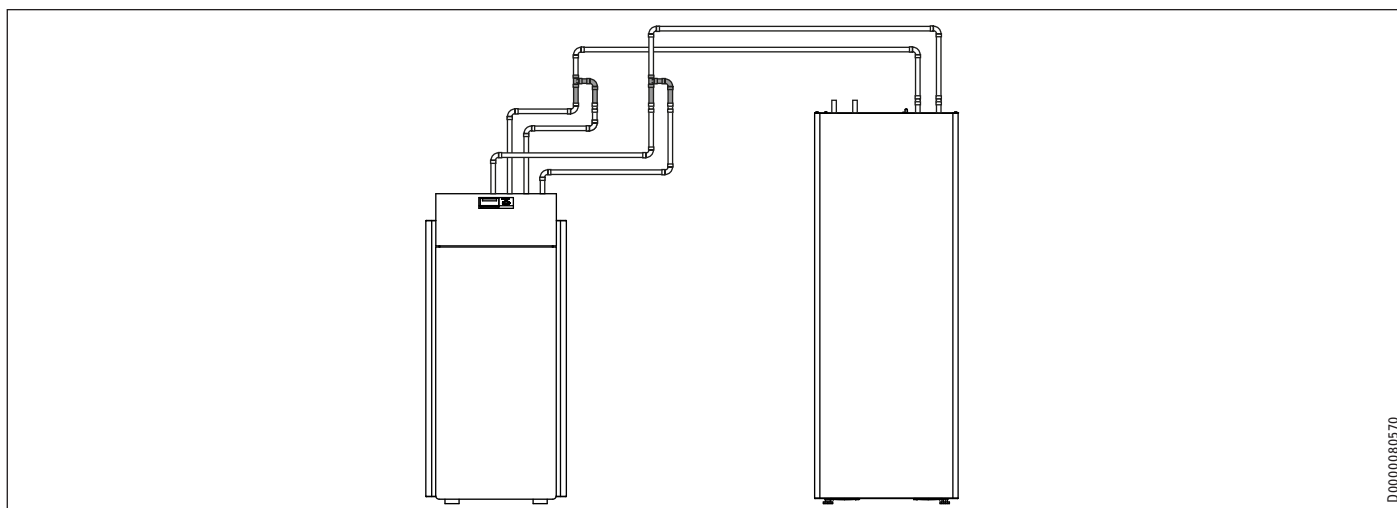
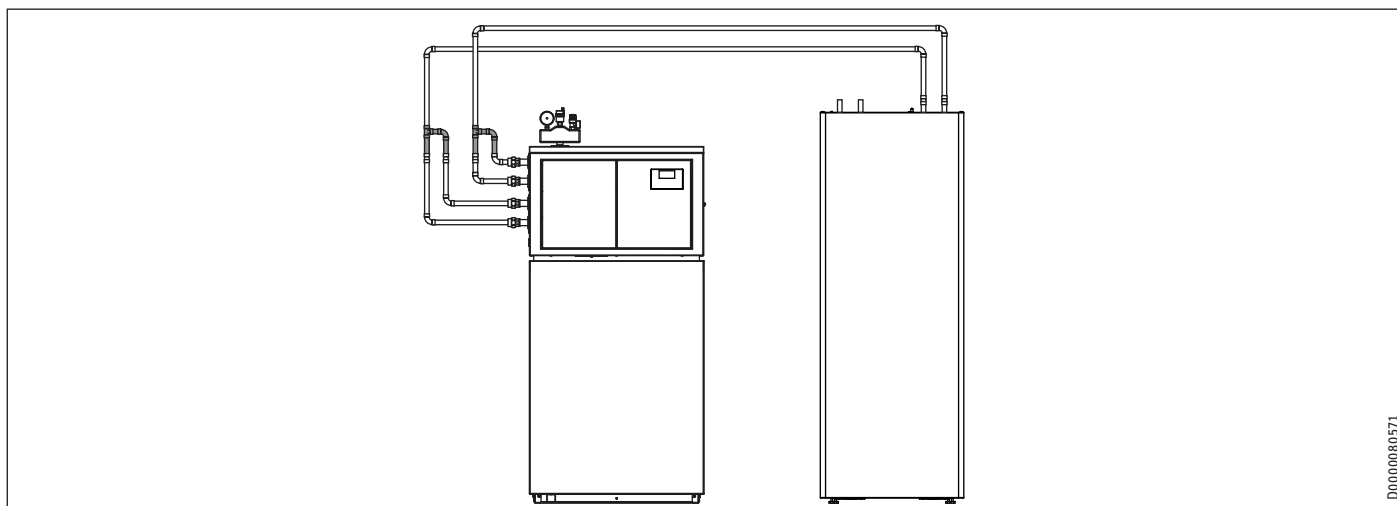

INSTALLATION Specification

15.4 Energy consumption data

Product datasheet: DHW cylinder to Regulation (EU) No 812/2013

		HSBC 300 cool 236686	HSBC 300 L cool 238826
Manufacturer		STIEBEL ELTRON	STIEBEL ELTRON
Designation		HSBC 300 cool	HSBC 300 L cool
Energy efficiency class		B	B
Standby losses	W	61	61
Cylinder capacity	l	291	291

15.5 Data table

		HSBC 300 cool 236686	HSBC 300 L cool 238826
Hydraulic data			
Nominal capacity, DHW cylinder	l	270	270
Nominal capacity, buffer cylinder	l	100	100
Surface area, indirect coil	m ²	3.3	3.3
Capacity, indirect coil	l	21	21
External available pressure differential, circulation pump/heat pump at 1.0 m ³ /h	hPa	656	
External available pressure differential, circulation pump/heat pump at 1.5 m ³ /h	hPa	527	
External available pressure differential, circulation pump/heat pump at 2.0 m ³ /h	hPa	210	
External available pressure differential, circulation pump / heating circuit 1 at 1.0 m ³ /h	hPa	725	725
External available pressure differential, circulation pump / heating circuit 1 at 1.5 m ³ /h	hPa	663	663
External available pressure differential, circulation pump / heating circuit 1 at 2.0 m ³ /h	hPa	444	444
External available pressure differential, circulation pump / heating circuit 2 (optional) at 1.0 m ³ /h	hPa	665	665
External available pressure differential, circulation pump / heating circuit 2 (optional) at 1.5 m ³ /h	hPa	518	518
External available pressure differential, circulation pump / heating circuit 2 (optional) at 2.0 m ³ /h	hPa	189	189
Application limits			
Max. permissible pressure, DHW cylinder	MPa	1.0	1.0
Test pressure, DHW cylinder	MPa	1.5	1.5
Max. flow rate	l/min	25	25
Max. permissible pressure, buffer cylinder	MPa	0.3	0.3
Test pressure, buffer cylinder	MPa	0.45	0.45
Max. permissible temperature	°C	85	85
Max. permissible temperature, primary side	°C	75	75
Heating water quality requirements			
Water hardness	°dH	≤3	≤3
pH value (with aluminium fittings)		8.0-8.5	8.0-8.5
pH value (without aluminium fittings)		8.0-10.0	8.0-10.0
Conductivity (softening)	µS/cm	<1000	<1000
Conductivity (desalination)	µS/cm	20-100	20-100
Chloride	mg/l	<30	<30
Oxygen 8-12 weeks after filling (softening)	mg/l	< 0.02	< 0.02
Oxygen 8-12 weeks after filling (desalination)	mg/l	< 0.1	< 0.1
Power consumption			
Max. power consumption, charging pump	W	60	
Max. power consumption, circulation pump on the heating side	W	60	60
Energy data			
Standby energy consumption/24 h at 65 °C	kWh	1.5	1.5
Energy efficiency class		B	B
Electrical data			
Frequency	Hz	50	50
Versions			
IP rating		IP20	IP20
Dimensions			
Height	mm	1918	1918
Width	mm	680	680
Depth	mm	910	910
Height when tilted	mm	2123	2123
Weights			
Weight, full	kg	641	639
Weight, empty	kg	250	248

INSTALLATION Specification

Further details

		HSBC 300 cool	HSBC 300 L cool
		236686	238826
Maximum altitude for installation	m	2000	2000

15.6 Accessories

Pipe assembly RBS-SBC

		RBS-SBC
		238827
Connections		
Cold water connection	mm	22
DHW connection	mm	22
DHW circulation connection	mm	12
Versions		
Suitable for	...SBC 300 cool / plus and 300 L cool / plus	

Pump assembly HSBC 3-HKM

		HSBC 3-HKM
		238825
Connections		
Heating circuit connection	mm	22

Auxiliary heating element HSBC 3-HE

		HSBC 3-HE
		200025
Electrical data		
Connected load ~ 230 V	kW	2
Rated voltage	V	230
Phases		1/N/PE
Frequency	Hz	50
Application limits		
Temperature setting range	°C	35-65
Max. permissible pressure	MPa	1.0
Minimum cylinder diameter	mm	500
Minimum cylinder volume	l	150
Dimensions		
Flange external diameter	mm	140
Immersion depth	mm	480
Torque	Nm	45
Weights		
Weight	kg	2

Guarantee

The guarantee conditions of our German companies do not apply to appliances acquired outside of Germany. In countries where our subsidiaries sell our products a guarantee can only be issued by those subsidiaries. Such guarantee is only granted if the subsidiary has issued its own terms of guarantee. No other guarantee will be granted.

We shall not provide any guarantee for appliances acquired in countries where we have no subsidiary to sell our products. This will not affect warranties issued by any importers.

Environment and recycling

We would ask you to help protect the environment. After use, dispose of the various materials in accordance with national regulations.