

## APPLICAZIONI

Le elettropompe della serie SQ, grazie ai numerosi accorgimenti applicati, costituiscono la soluzione ai problemi di convogliamento di acque di pubblico esercizio, di liquidi provenienti da depuratori, da impianti fognari, da allevamenti zootecnici, da macelli e salumifici, da fonderie, dal settore agricolo e per l'irrigazione. Applicabili nell'industria ittica, cartaria, nell'impiantistica civile residenziale, a contatto con fanghi industriali di bassa o media densità. Elettropompe con girante monocanale aperta che offre ampi passaggi liberi ed ottimi rendimenti.

## APPLICATION

Thanks to their important features, SQ pumps are the ideal solution for the carriage of waters coming from cleaners, sewing systems, zootechnic farms, slaughter-houses, foundries and for irrigation in agricultural field. Applicable in fishing industry, paper mills and in civil and industrial plants. The pumps adopt open single-blade impeller which allows free passage of suspended parts and high performance.

### LIMITI D'IMPIEGO

- Temperatura liquido 0 ÷ 35°C (secondo EN 60335-2-41) fino a 50°C (per altri impieghi)
- Profondità d'immersione max. 5 mt.
- PH liquido da 4 a 10
- Servizio continuo a pompa completamente sommersa
- Densità liquido 1,2 Kg/dm<sup>3</sup>

### OPERATING CONDITIONS

- Liquid temperature 0 ÷ 35°C (according to EN 60335-2-41) up to 50°C (for other uses)
- Submersion depth max. 5 mt.
- Liquid PH from 4 to 10
- Continuous duty with completely submersed pump
- Liquid density 1,2 Kg/dm<sup>3</sup>

### MOTORE

- Isolamento Classe F
- Protezione IP 68
- Protettore termico

### MOTOR

- Insulation Class F
- Protection IP 68
- Thermic protection

### MATERIALI

- Corpo motore Ghisa
- Corpo pompa Ghisa
- Girante Ghisa
- Albero motore Acciaio Inox
- Tenuta meccanica Ceramica/Grafite

### MATERIALS

- Motor body Cast iron
- Pump body Cast iron
- Impeller Cast iron
- Shaft with rotor Stainless steel
- Mechanical seal Ceramic/Graphite

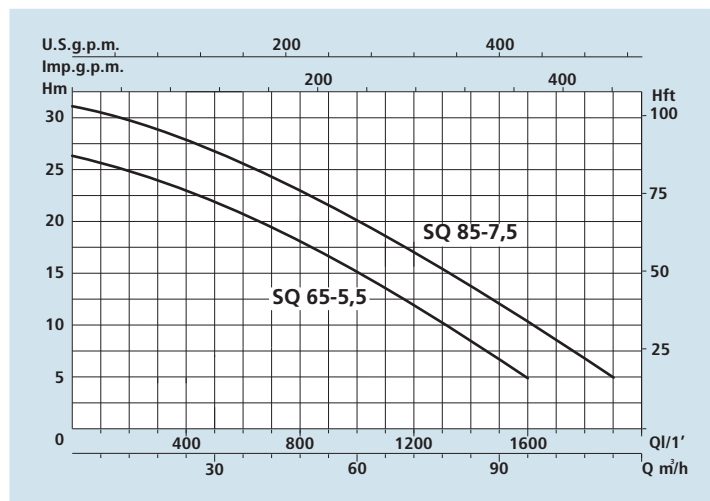
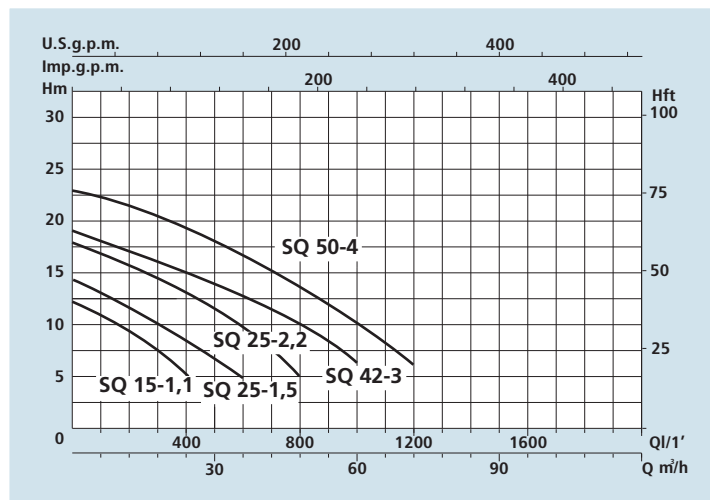

## DATI TECNICI - TECHNICAL DATA

TIPO - TYPE	POTENZA NOMINALE		POTENZA ASSORBITA	AMPERE	Q = PORTATA - CAPACITY															
	NOMINAL POWER P2		INPUT POWER P1		Trifase Three-phase		m <sup>3</sup> /h	6	12	24	36	48	60	72	84	96	114			
230/400V-50Hz	HP	KW	KW	3 x 400V	lt/1'	100	200	400	600	800	1000	1200	1400	1600	1900	Prevalenza manometrica totale in m.C.A. - Total head in meters w.c.				
SQ 15-1,1	1,5	1,1	1,7	2,9	H (m)	11	8	5												
SQ 25-1,5	2	1,5	2	3,8		13	11	8	5											
SQ 25-2,2	3	2,2	3	5,4		17	16	13	8	5										
SQ 42-3	4	3	4	7		18	17	15	13	10	6									
SQ 50-4	5	4	5	9,3		22	21	19	16	13	10	6								
SQ 65-5,5	7,5	5,5	7,5	12,3		25	24	23	21	18	15	12	8	5						
SQ 85-7,5	10	7,5	10	16,5		31	30	28	25	23	20	18	15	11	5					

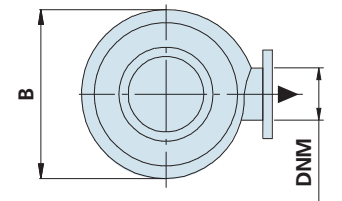
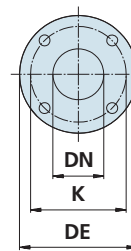
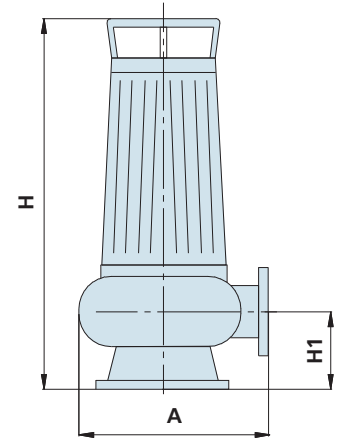

Tipo - Type	DIMENSIONI mm - DIMENSIONS mm					
	DN	DE	K	fori - holes n°	Ø	flange flanges
SQ 15-1,1	50	140	110	4	14	2"
SQ 25-1,5	50	140	110	4	14	2"
SQ 25-2,2	50	140	110	4	14	2"
SQ 42-3	80	190	150	4	18	3"
SQ 50-4	80	190	150	4	18	3"
SQ 65-5,5	100	210	170	4	18	4"
SQ 85-7,5	100	210	170	4	18	4"

DIMENSIONI E PESI - DIMENSIONS AND WEIGHTS

TIPO - TYPE	DIMENSIONI mm - DIMENSIONS mm						DIMENSIONI DIMENSIONS mm			Peso Weight Kg
	A	B	H	H1	Passaggio solidi (mm) Grain size inlet (mm)	CAVO CABLE	P	L	H	
Trifase Three-phase										
SQ 15-1,1	210	200	470	100	Ø 40	10 mt H07RNF	310	240	510	34
SQ 25-1,5	270	230	500	100	Ø 40	10 mt H07RNF	350	280	580	44
SQ 25-2,2	270	230	520	100	Ø 40	10 mt H07RNF	350	280	580	47
SQ 42-3	310	270	580	125	Ø 60	10 mt H07RNF	400	320	770	77
SQ 50-4	310	270	600	125	Ø 60	10 mt H07RNF	400	320	770	79
SQ 65-5,5	330	280	670	130	Ø 70	10 mt H07RNF	450	370	980	119
SQ 85-7,5	330	280	700	130	Ø 70	10 mt H07RNF	450	370	980	123