



FULL DC INVERTER SYSTEMS

OWNER'S MANUAL

SDV4-400EAA, SDV4-450EAA

COMMERCIAL AIR CONDITIONERS SDV4



“Original instructions”

IMPORTANT NOTE:

Read this manual carefully before installing or operating your new air conditioning unit. Make sure to save this manual for future reference.

This air conditioner comprises an indoor unit, outdoor unit, and a connection pipe.

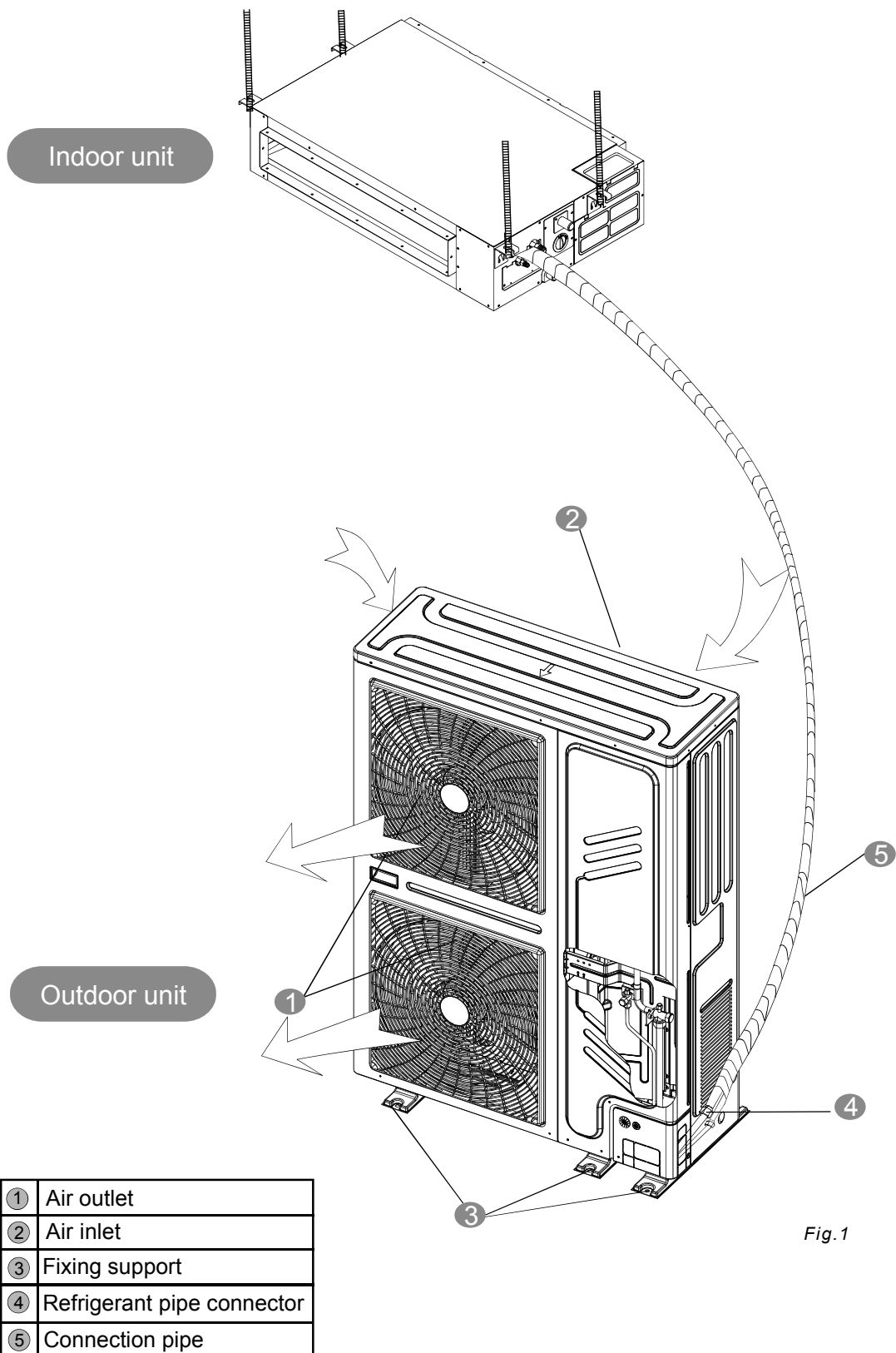

NOTE

All the pictures in this manual are for explanation purpose only. They may be slightly different from the air conditioner you purchased (depend on model). The actual shape shall prevail.

CONTENTS	PAGE
IMPORTANT SAFETY INFORMATION.....	1
OPERATION METHOD.....	2
REINSTALLATION.....	4
MAINTENANCE.....	5

1. IMPORTANT SAFETY INFORMATION

To prevent injury to the user or other people and property damage, the following instructions must be followed. Incorrect operation due to ignoring of instructions may cause harm or damage.

The safety precautions listed here are divided into two categories. In either case, important safety information is listed which must be read carefully.



WARNING

Failure to observe a warning may result in death. The appliance shall be installed in accordance with national wiring regulations.



CAUTION

Failure to observe a caution may result in injury or damage to the equipment.



WARNING

Ask your dealer for installation of the air conditioner.
Incomplete installation performed by yourself may result in a water leakage, electric shock, and fire.

Ask your dealer for improvement, repair, and maintenance.
Incomplete improvement, repair, and maintenance may result in a water leakage, electric shock, and fire.

In order to avoid electric shock, fire or injury, or if you detect any abnormality such as smell of fire, turn off the power supply and call your dealer for instructions.

Never let the indoor unit or the remote controller get wet.
It may cause an electric shock or a fire.

Never press the button of the remote controller with a hard, pointed object.
The remote controller may be damaged.

Never replace a fuse with that of wrong rated current or other wires when a fuse blows out.
Use of wire or copper wire may cause the unit to break down or cause a fire.

It is not good for your health to expose your body to the air flow for a long time.

Do not insert fingers, rods or other objects into the air inlet or outlet.
When the fan is rotating at high speed, it will cause injury.

Never use a flammable spray such as hair spray, lacquer or paint near the unit.
It may cause a fire.

Never touch the air outlet or the horizontal blades while the swing flap is in operation.

Fingers may become caught or the unit may break down.

Never put any objects into the air inlet or outlet.
Objects touching the fan at high speed can be dangerous.

Never inspect or service the unit by yourself.
Ask a qualified service person to perform this work.

Do not dispose this product as unsorted municipal waste. Collection of such waste separately for special treatment is necessary.
Do not dispose of electrical appliances as unsorted municipal waste, use separate collection facilities.



Contact your local government for information regarding the connection systems available.

If electrical appliances are disposed of in landfills or dumps, hazardous substances can leak into the ground and get into the food chain, damaging your health and well-being.

To prevent refrigerant leak, contact your dealer.
When the system is installed and runs in a small room, it is required to keep the concentration of the refrigerant, if by any chance coming out, below the limit. Otherwise, oxygen in the room may be affected, resulting in a serious accident.

The refrigerant in the air conditioner is safe and normally does not leak.
If the refrigerant leaks in the room, contact with a fire of a burner, a heater or a cooker may result in a harmful gas.

Turn off any combustible heating devices, ventilate the room, and contact the dealer where you purchased the unit.
Do not use the air conditioner until a service person confirms that the portion where the refrigerant leaks is repaired.

If the supply cord is damaged, it must be replaced by the manufacturer, its service agent or similarly qualified person in order to avoid a hazard.



CAUTION

Do not use the air conditioner for other purposes.
In order to avoid any quality deterioration, do not use the unit for cooling precision instruments, food, plants, animals or works of art.

Before cleaning, be sure to stop the operation, turn the breaker off or pull out the supply cord.
Otherwise, an electric shock and injury may result.

In order to avoid electric shock or fire, make sure that an earth leak detector is installed.

Be sure the air conditioner is grounded.
In order to avoid electric shock, make sure that the unit is grounded and that the earth wire is not connected to gas or water pipe, lightning conductor or telephone earth wire.

In order to avoid injury, do not remove the fan guard of the outdoor unit.

Do not operate the air conditioner with a wet hand.
An electric shock may happen.

Do not touch the heat exchanger fins.
These fins are sharp and could result in cutting injuries.

Do not place items which might be damaged by moisture under the indoor unit.

Condensation may form if the humidity is above 80%, the drain outlet is blocked or the filter is polluted.

After a long use, check the unit stand and fitting for damage.

If damaged, the unit may fall and result in injury.

To avoid oxygen deficiency, ventilate the room sufficiently if equipment with burner is used together with the air conditioner.

Arrange the drain hose to ensure smooth drainage.

Incomplete drainage may cause wetting of the building, furniture etc.

Never touch the internal parts of the controller.

Do not remove the front panel. Some parts inside are dangerous to touch, and a machine trouble may happen.

Never expose little children, plants or animals directly to the air flow.

Adverse influence to little children, animals and plants may result.

Do not allow a child to mount on the outdoor unit or avoid placing any object on it.

Falling or tumbling may result in injury.

Do not operate the air conditioner when using a room fumigation - type insecticide.

Failure to observe could cause the chemicals to become deposited in the unit, which could endanger the health of those who are hypersensitive to chemicals.

Do not place appliances which produce open fire in places exposed to the air flow from the unit or under the indoor unit.

It may cause incomplete combustion or deformation of the unit due to the heat.

Do not install the air conditioner at any place where flammable gas may leak out.

If the gas leaks out and stays around the air conditioner, a fire may break out.

This appliance can be used by children age from 8 years and above and persons with reduced physical, sensory or mental capabilities or lack of experience and knowledge if they have been given supervision or instruction concerning use of the appliance in a safe way and understand the hazards involved, children should not play with This appliance. Cleaning and user maintenance should not be made by children without supervision.

When capacity of indoor unit greater than the sum of 100%, capacity of indoor unit will be attenuated.

When capacity of indoor unit greater than or equal to the sum of 120%, in order to ensure the effectiveness of machine, and then try to open the indoor units at different time.

The outdoor unit window-shades should be periodic cleaning in case of being jammed.

This window-shapes is heat dissipation outlet of components, if being jammed will cause the components shorten their service life spans because of overheated for a long time.

The temperature of refrigerant circuit will be high, please keep the interconnection cable away from the copper tube.

Poor environmental conditions, the appliance should be maintained a month and a half or so; if the environment condition is good, may be extended appropriately maintenance cycle.

The A-weighted sound pressure level is below 70dB.

1.1 Electrical safety requirements

1. Wiring job must be done by the certified electrician.
2. Wiring work must comply to electrical safety specifications.
3. Be sure the air conditioner is grounded well which means the main power switch of air-conditioner grounded with reliable grounded wire.
4. Make sure the min. space between PTC electrical heating elements and flammable surface is >12mm.
5. Apply separate power which meet the rated parameters for the air-conditioner

1.2 Electrical performance requirements

Table 1-1

Model	Fuse(A)	Power supply specification
33.5kW/40kW	40A	380-415V 3N~ 50Hz
45kW	50A	



CAUTION

Under any situations, it can not break off the ground wire of the main power switch.

Can not use broken power wire, if there is any broken wire then change it immediately.

First use the unit or the unit under the power off state for a long time, power on and pre-heat the unit at least 12 hours before using.

2. OPERATION METHOD

2.1 Operation conditions under each mode

Use the unit in the following temperature for safe and effective operation.

Table 2-1

Cooling operation	Indoor temp. : 21°C to 32°C
	Outdoor temp.: -5°C to 48°C
Heating operation	Indoor temp. : under 28°C, above 0°C
	Outdoor temp.: -15°C to 24°C



CAUTION

- Protection device may start if running the unit outside the above condition, which will prevent the unit from operation.
- Under "Cool" operation, room relative humidity should be less than 80%. If higher than 80%, the surface of indoor unit may be condensed or the condensate will be blown from air outlet.
If less than 80%, please move the air leading bar to the largest air outlet position (which is vertical direction), and set the fan speed to be "High".

2.2 Constraint Cooling

1.Constraint Cooling

Outdoor unit main control board has constraint cooling key: SW1 (see Fig.2-1). One press will send constraint cooling signal to all the indoor unit. Constrain all the indoor unit to constraint cooling operation. Outdoor units operate as the fixed frequency shown in Table 2-2. Indoor unit fan operate at a high speed and press the key again to log out constraint cooling mode.

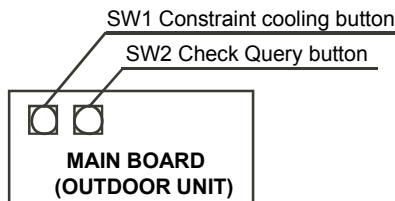

Fig.2-1

Table of force cooling frequency

Table 2-2

Mode	Force cooling rate(Hz)
33.5kW/40kW	62
45kW	48

2. Spot check

Check in the outdoor main control panel is the spot check button (refer to Fig.2-1), and press this button, the digital pipe of the main control panel will circulating display the parameters (display one parameter every press this button) as the following table 2-3 sequence.

SW2 Query instructions

Table 2-3

NO.	Normal display	Display content	Note
1	0. --	Outdoor unit address	0
2	1. --	Outdoor unit itself capacity	8, 10, 12, 14, 16, 18
3	2. --	Moduler outdoor unit Qty	Reserve
4	3. --	Qty.setting of indoor units	Available for main unit
5	4. --	Total capacity of outdoor unit	Reserve
6	5. --	Total requirement of indoor unit capacity	Available for main unit
7	6. --	Total requirement of main unit corrected capacity	Available for main unit
8	7. --	Operation mode	0, 2, 3, 4
9	8. --	This outdoor unit actual operation capacity	Capacity requirement
10	9. --	Speed of fan A	0, 1,, 9, 10
11	10. --	Speed of fan B	0, 1,, 9, 10
12	11. --	T2B/T2 average Temp.	Actual value
13	12. --	T3/T3A pipe Temp.	Actual value
14	13. --	T4 ambient Temp	Actual value
15	14. --	Discharge Temp.of Inverter compressor A	Actual value
16	15. --	Discharge Temp.of Inverter compressor B	Actual value
17	16. --	Radiator temperature	
18	17. --	Current of inverter compressor A	Actual value
19	18. --	Current of inverter compressor B	Actual value
20	19. --	Opening angle of EXV A	
21	20. --	Opening angle of EXV B	
22	21. --	High pressure	Reserve
23	22. --	T3B	Reserve for 33.5kW/40kW
24	23. --	Qty. of Indoor units	That can communicate with indoor units
25	24. --	Qty. of the working Indoor units	Actual value
26	25. --	Priority mode	0, 1, 2, 3, 4
27	26. --	Night noise control mode	0, 1, 2, 3
28	27. --	Static pressure mode	Reserved
29	28. --	DC voltage A	Actual value±10
30	29. --	DC voltage B	Actual value±10
31	30. --	Version of the program	
32	31. --	The last error or protection code	Without error or protection,display code 8.8.
33	32. --	---	Check end

The display contents as followings:

Normal display: When standby, the high position displays the address of the outdoor unit, and the low position displays the Qty. of indoor units that can communicate with outdoor unit. When it is operating, it will display the rotation frequency of the compressor.

- 1) Operation mode: 0-OFF; 2-Cooling; 3-Heating; 4-Constraint cooling;
- 2) Fan speed: 0-stop; 1~10: speed increase sequentially, 10 is the max. fan speed.
- 3) EXV opening angle: Pulse count=display value*8;
- 4) Priority mode: 0-heating priority mode; 1-cooling priority mode; 2-open the priority mode first; 3-respond the heating mode only; 4-respond the cooling mode only.
- 5) Night noise control mode: 0-Night noise control mode; 1-silent mode; 2-reserve; 3-no priority.

2.3 5-minute protection feature

- A protection feature prevents the air conditioner from being activated for approximately 5 minutes when it restarts immediately after operation.

2.4 Cooling, Heating, operation of DC speed regulation central A/C

- The indoor unit can be controlled separately, but indoor units in the same system can not simultaneously operate the cooling and heating.
- If there is conflict between cooling mode and heating mode, the indoor unit under cooling operation will stop and the operating panel will display "Non-priority" or "Standing-by" code. The indoor unit under heating operation will operate normally.
- If the administrator has fixed set the cooling or heating operation, it can not do the operations beyond the setting. When do the operations beyond the setting, the operating panel will display "Non-priority" or "Standing-by" code and the unit stops.

2.5 Features of heating operation

- Warm air will not be blown out immediately at the beginning of the heating operation, 3~5 minutes later (depends on the indoor and outdoor temperature), until the indoor heat exchanger become hot, then blows out warm air.
- During operation, the fan motor in the outdoor unit may stop running under high temperature.

2.6 Defrosting in heating operation

- During heating operation, outdoor unit sometimes will frost. To increase efficiency, the unit will start defrosting automatically (about 2~10 minutes), and then water will be drained out from outdoor unit.
- During defrosting, both the fan motors in the outdoor unit and indoor unit will stop running.

2.7 Heating capacity

- The heating operation is a heat-pump process that heat will be absorbed from outdoor air and released in doors. Once the outdoor temperature is decreased, heating capacity decreased correspondingly.
- Other heating equipment is suggested to be used together when outdoor temperature is too low.
- In alpine region where the temperature is extremely low, heating effect will be better if users can buy an additional E-heat device.

2.8 About protection equipment

- This Protection Equipment will enable the Air Conditioner to stop when the Air Conditioner is to be directed running compulsively. When the Protection Equipment is activated, the Operation Indicator still lights while the Air Conditioner is not running.
The protection equipment may be activated in following conditions:
- Under cooling operation, the air inlet or air outlet of outdoor unit is blocked. Strong wind is continuously blowing to the air outlet of the outdoor unit.
- Under heating operation, too much dust and rubbish adhere to the dust filter in the indoor unit. The air outlet of indoor unit is choked.



CAUTION

- When the protection equipment starts, please shut down the manual power switch, and restart operation after problem is solved.

2.9 Mishandling in operation

- If mishandling happens because of lighting or mobile wireless, please shut off the manual power switch, and turn on again, then push the ON/OFF button.

2.10 About power cut

- If power is cut during operation, stop all the operation immediately.
- Power comes again. The lamp on the display panel of indoor unit flashes. And then unit will auto-restart.

3. REINSTALLATION



CAUTION

- A/C installation should comply with the regulations in GB17790-2008 and the requirements in Installation manual.
- When moving the A/C to another place, install the unit according to Installation manual by a specialized person.
- Improper installation could lead to electric shock or fire.



3.1 Users' instruction

1. Users should use the certified power supply corresponding to the A/C nameplate, actual voltage should be within 90%~110% of the rated voltage.
2. RCCB and air switch should be installed in the power supply circuit, the capacity should be 1.5 times of A/C maximum current value. Be sure to use specialized circuit.
3. Use specified fuse or RCCB under installation manual.
4. Wiring operations should be applied by electricians, and must comply with electrical appliance safety regulations.
5. Make sure the A/C has been grounded wiring properly. The main switch of A/C must reliably ground wiring.
6. If the power supply cable needs to be change, please contact our A/C customer service center or special technology service department to operate by a specialized person.

3.2 Installation position

1. Do not install the unit in such places

- 1) Don't install it in the place where TV, stereo phonographs and radio distance the unit less than 1m, noise made by A/C could affect those appliances.
- 2) Don't install high frequency equipment near the unit, (e.g. commercial sewing machine or massager), or the A/C may fail.
- 3) Do not place items which might be damaged by moisture under the indoor unit.
- 4) Don't install it in a salty place, such as nearby the sea.
- 5) Do not install the air conditioner at any place where flammable gas may leak out.
- 6) Don't install it in the place where there's strong wind, e.g. seashore, roof or high floor of a tall building.
- 7) Don't install it nearby a hot spring where sulfur gas leaks.
- 8) Don't install it in the ship or a moving crane.

2. For the detailed requirements, please go over Installation Manual

For the detailed information, please refer to Installation manual.



CAUTION

- Please install the unit securely or abnormal noise and vibration will be heard.
- Install the outdoor unit where operation noise and discharged air couldn't affect neighbours.

4. MAINTENANCE

4.1 Confirmation before operating

1. Make sure if the ground wire is broken or fall off.
2. Make sure if a air strainer has been installed.
3. Start the power supply switch 12 hours before operating.

4.2 NON-A/C errors

1. For common protections, please refer to indoor unit operation manual.
2. For NON-A/C errors, please refer to indoor unit operation manual.

4.3 Error information and code

If the following situation happens, please stop the unit and cut off the power supply and contact with local customer service center.

Table 4-1

Display	Code	Malfunction or Protection	Remarks
1	E0	Outdoor unit COMM.Error	
2	E1	Phase protection	
3	E2	COMM.Error with indoor unit	In or after 20min,communication breaks 2 times for the first time to electrified
4	E4	Outdoor Temp. sensor error	
5	E5	Voltage protection	
6	E7	Discharge sensor error	If discharge temp. is below 15°C for 5 min after 10 minutes operating, displays E7, when GAS is higher than 25°C, it recovers
7	E8	Outdoor unit address error	
8	xE9	Wrong drive model	X represents in which system, 1 is system A, 2 is system B
9	EA	5-min protection in A zone(heating fan)	
10	xH0	COMM. Error between IR341 and main chip	X represents in which system, 1 is system A, 2 is system B
11	H1	COMM. Error between 0537 and main chip	
12	xH4	3 times of P6 protection in 60 munites	X represents in which system, 1 is system A, 2 is system B, Not recoverable until re-power on
13	H5	3 times of P2 protection in 60 munites	Not recoverable until re-power on
14	H6	3 times of P4 protection in 100 munites	Not recoverable until re-power on
15	H7	Qty.of indoor units decreases error	Indoor unit lost for over 3 munites; not recoverable,until the unit qty. recover
16	H9	3 times of P9 protection in 60 minutes	Not recoverable until re-power on
17	dF	Defrosting	
18	d0	Oil returning	
19	P1	High pressure protection or discharge temperature switch protection	
20	P2	Low pressure protection	
21	xP3	Compressor current protection	X represents in which system, 1 is system A, 2 is system B
22	P4	High discharge Temp.Protection	
23	P5	High condenser Temp.Protection	
24	xP6	Inverter module protection	X represents in which system, 1 is system A, 2 is system B
25	P9	DC fan protection	
26	PE	Evaporator T2 high temp. protection	
27	PL	The Temp.protection of inverter module	
28	G7	3 times of PL protection in 90 minutes	Not recoverable until re-power on
29	xL0	DC compressor module error	X represents in which system, 1 is system A, 2 is system B
30	xL1	DC bus low pressure protection	X represents in which system, 1 is system A, 2 is system B
31	xL2	DC bus high voltage protection	X represents in which system, 1 is system A, 2 is system B
32	xL4	MCE malfunction/simultaneously/cycle loop	X represents in which system, 1 is system A, 2 is system B
33	xL5	Zero speed protection	X represents in which system, 1 is system A, 2 is system B
34	xL7	Compressor wrong phase protection	X represents in which system, 1 is system A, 2 is system B
35	xL8	Compressor speed difference in one second more than 15rps	X represents in which system, 1 is system A, 2 is system B
36	xL9	Compressor speed difference between setting speed and running speed more than 15rps	X represents in which system, 1 is system A, 2 is system B

If the problem still existing, please contact the sales distributor or the service center, tell us your model No. and the detail of the error.



CAUTION

Please do not change the power supply by yourself in case of danger; and do not fix the air-conditioner by yourself.

4.4 Cleaning



WARNING

- Stop the unit and cut off the power before cleaning for safety's sake.
 - Pay attention to T1 thermal bulb when cleaning. DO NOT drop T1 thermal bulb cable, or dismantle it before cleaning and reinstall after cleaning.
-

1. Outdoor units

- 1) Some metal edges and condenser blades are very sharp, improper operation could lead injury. Therefore, be extremely careful when cleaning these parts.
- 2) Inspect outdoor unit air outlet and inlet regularly, to check if they are blocked by dirt or lampblack.
- 3) Window-shade at right bottom side and back side are heat dissipation air inlet of electric control components, clean it regularly to avoid super hot in the components.

2. For detailed information about cleaning, please refer to Indoor unit operation manual.

4.5 Maintenance



CAUTION

After leaving unused for a long time, inspect the air inlet and air outlet port of indoor and outdoor unit. See if it has been blocked, if it is blocked, do cleaning immediately

Before a long-time idling, please do the following work:

1. Choose "air supply mode" and leave the indoor unit operates for a while for drying.
2. Cut off the power supply and stop the RCCB. Take battery out of the remote control.
3. Outdoor unit internal components should be inspected and cleaned regularly, please contact the service center or technical services department.

4.6 After-sale service

When the air-conditioner can't operate normally, please stop the unit and cut off the power supply. Please contact the service center or technical services department. For the detailed items, please refer to Users' guide in accessory.

NOTE CONCERNING PROTECTION OF ENVIRONMENT



This product must not be disposed of via normal household waste after its service life, but must be taken to a collection station for the recycling of electrical and electronic devices. The symbol on the product, the operating instructions or the packaging indicate such disposal procedures. The materials are recyclable in accordance with their respective symbols. By means of re-use, material recycling or any other form of recycling old appliances you are making an important contribution to the protection of our environment. Please ask your local council where your nearest disposal station is located.

INFORMATION CONCERNING USED REFRIGERANT MEDIUM

This unit is containing fluorinated gases included in the Kyoto protocol. The maintenance and the liquidation must be carried out by qualified personnel.

Type of refrigerant: R410A

The composition of the cooling medium R410A: (50% HFC-32, 50% HFC-125)

The quantity of the refrigerant: please see the unit label.

The value GWP: 2088 (1 kg R410A = 2,088 t CO₂ eq)

GWP = Global Warming Potential

In case of quality problem or other please contact your local supplier or authorized service center.

Emergency number: 112

PRODUCER

SINCLAIR CORPORATION Ltd.

1-4 Argyll St.

London W1F 7LD

Great Britain

www.sinclair-world.com

This product was manufactured in China (Made in China).

REPRESENTATIVE

SINCLAIR EUROPE spol. s r.o.

Purkynova 45

612 00 Brno

Czech Republic

TECHNICAL SUPPORT

NEPA spol. s r.o.

Purkynova 45

612 00 Brno

Czech Republic

Tel.: +420 800 100 285

Fax: +420 541 590 124

www.sinclair-solutions.com

info@sinclair-solutions.com

