



MODULAR CONDENSATION SYSTEMS

DEWY EQUIPE 60-360 BOX

Premixed,
condensing boilers
for C.H. only
with fanned flue

- ▶ *wall hung premixed
condensing boilers*

- ▶ *heat output:
16.8 ÷ 373.4 kW*



1 DEVICE DESCRIPTION

1.1 INTRODUCTION

"DEWY EQUIPE 60-120 BOX" are pre-mixed condensation heating modules intended only for heating, inter-connectible and

easy to assemble, designed to work singularly or in sequence/cascade autonomously.

They are designed and constructed to meet European directives

90/336/CEE, 73/23/CEE and European regulation EN 483.

NOTE: Authorised personnel must turn on the device the first time.

1.2 DIMENSIONS MODULES

1.2.1 "DEWY EQUIPE 60-120 BOX"

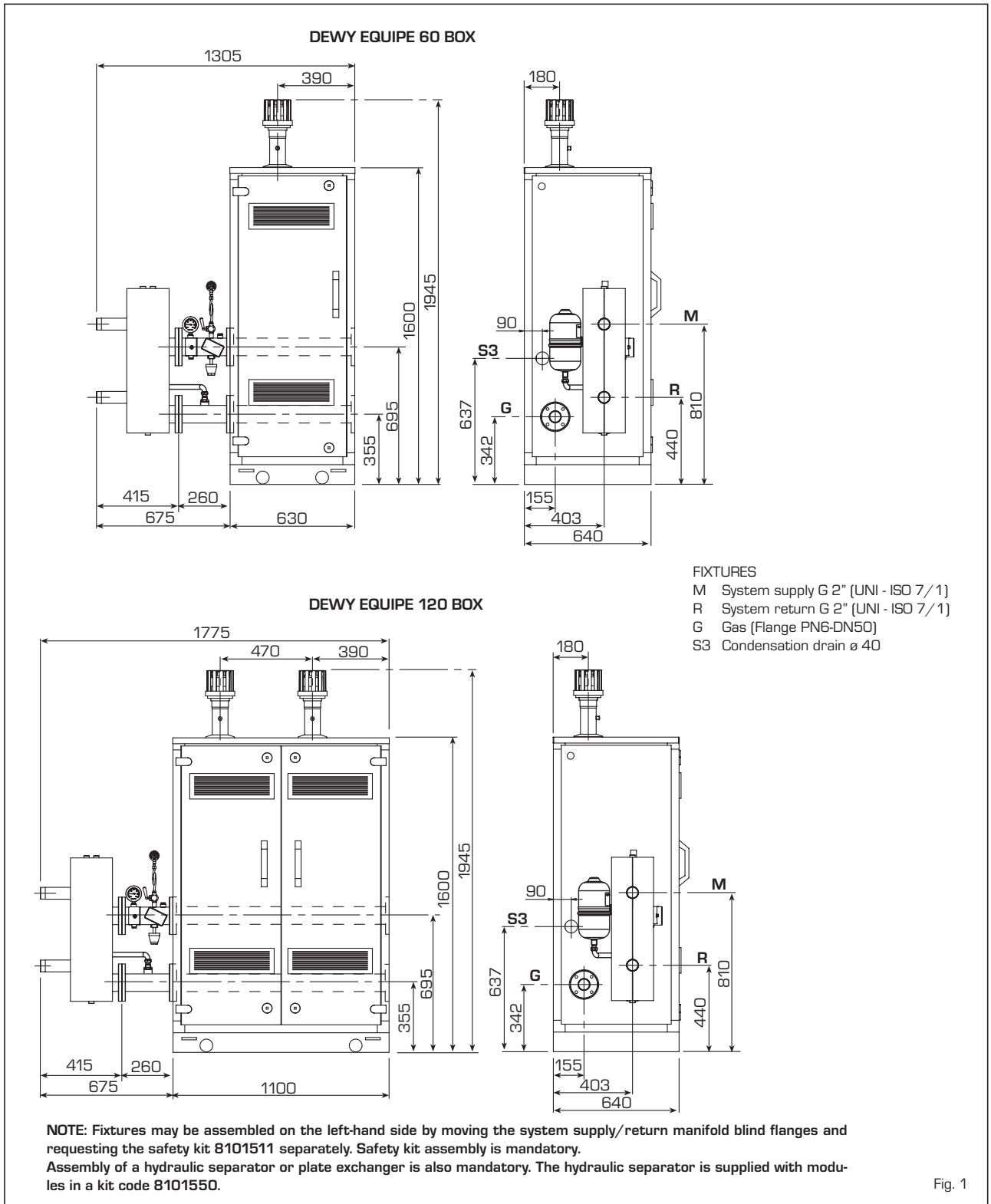
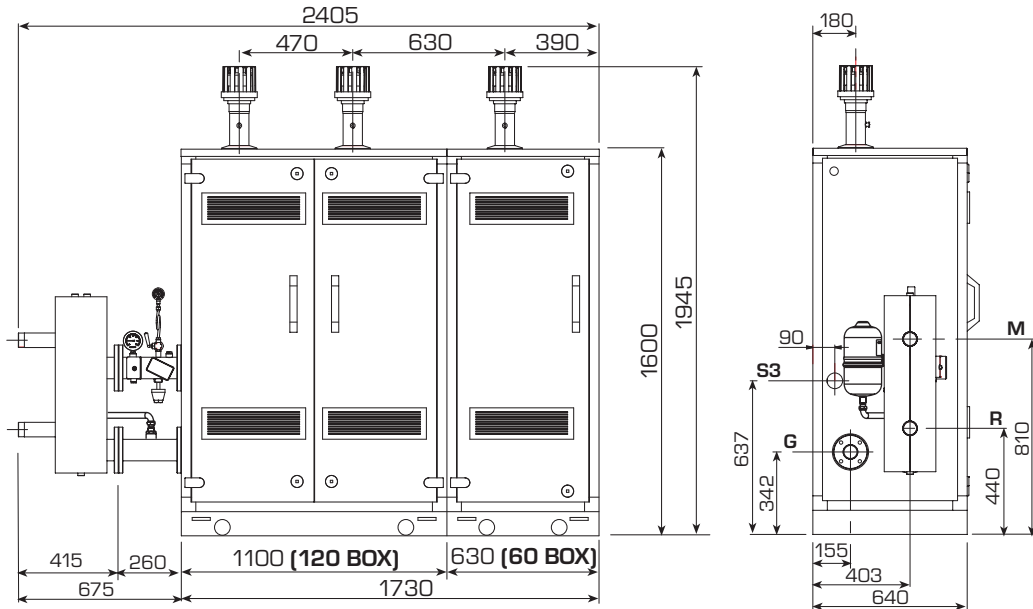

Fig. 1

1.2.2 "DEWY EQUIPE 180-240 BOX"

DEWY EQUIPE 180 BOX



FIXTURES

- M System supply G 2" (UNI - ISO 7/1)
- R System return G 2" (UNI - ISO 7/1)
- G Gas (Flange PN6-DN50)
- S3 Condensation drain \varnothing 40

DEWY EQUIPE 240 BOX

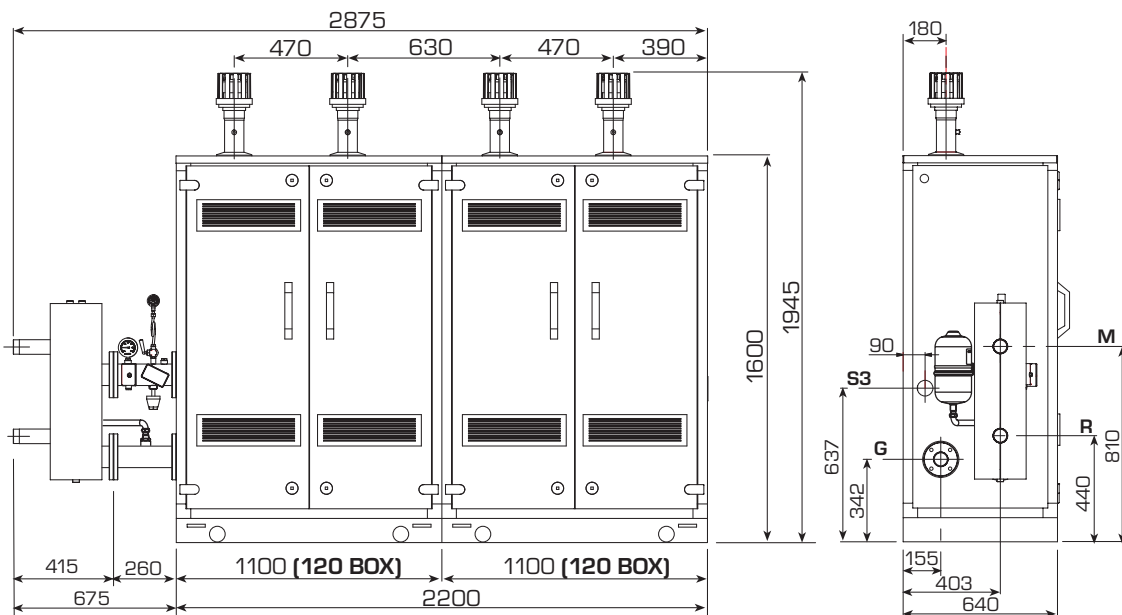

NOTE: Fixtures may be assembled on the left-hand side by moving the system supply/return manifold blind flanges and requesting the safety kit 8101511 separately. Safety kit assembly is mandatory. Assembly of a hydraulic separator or plate exchanger is also mandatory. The hydraulic separator is supplied with modules in a kit code 8101550.

Fig. 1/a

1.2.3 "DEWY EQUIPE 300-360 BOX"

DEWY EQUIPE 300 BOX

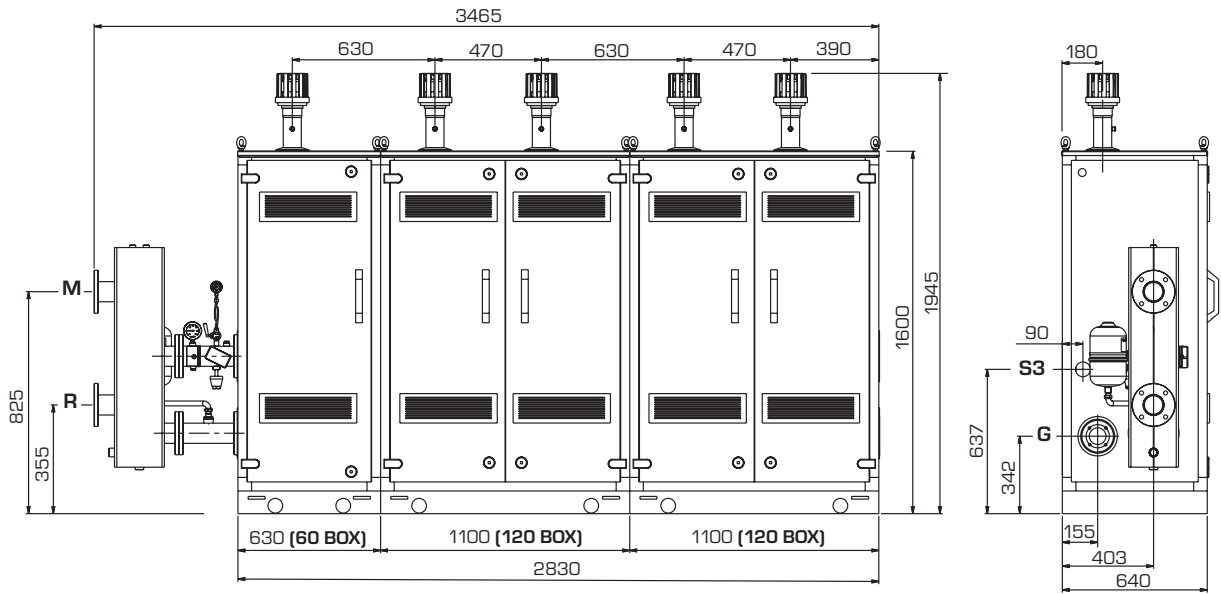

FIXTURES

- M System supply (Flange PN6-DN80)
- R System return (Flange PN6-DN80)
- G Gas (Flange PN6-DN50)
- S3 Condensation drain ø 40

DEWY EQUIPE 360 BOX

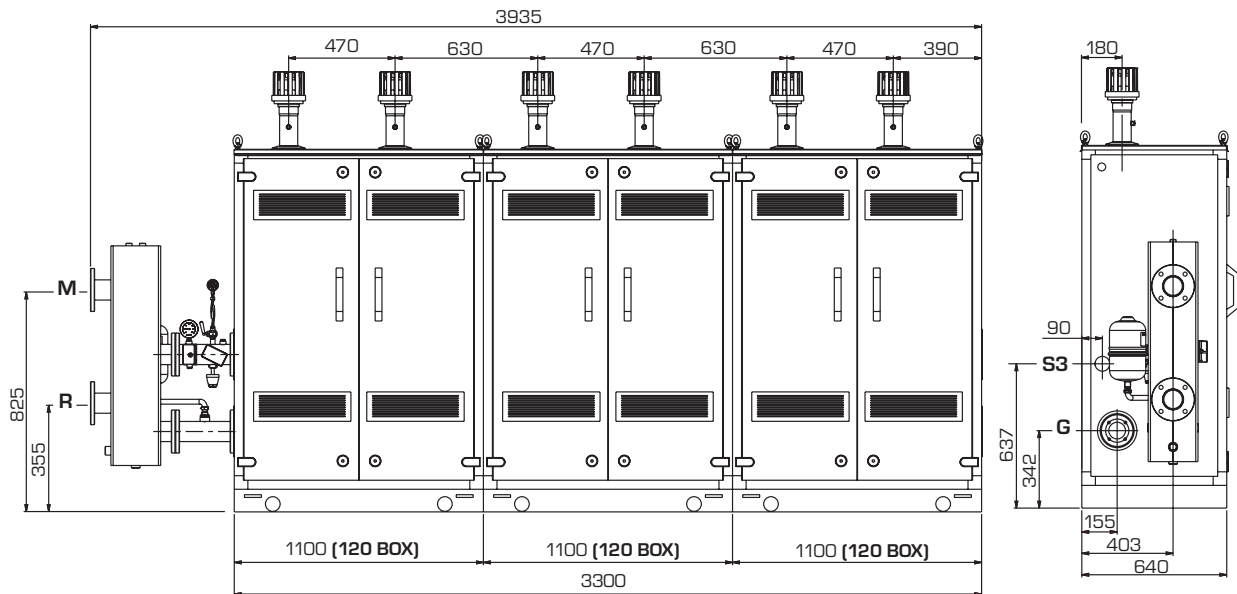

NOTE: Fixtures may be assembled on the left-hand side by moving the system supply/return manifold blind flanges and requesting the safety kit 8101511 separately. Safety kit assembly is mandatory. Assembly of a hydraulic separator or plate exchanger is also mandatory. The hydraulic separator is supplied with modules in a kit code 8101551.

Fig. 1/a

1.3 TECHNICAL SPECIFICATIONS

DEWY EQUIPE		60 BOX	120 BOX	180 BOX	240 BOX	300 BOX	360 BOX
Nominal heat output (80-60°C)	kW	57,0	113,9	170,9	227,8	284,8	341,7
	kcal/h	49.000	98.000	146.900	196.000	244.900	293.900
Nominal heat output (50-30°C)	kW	62,2	124,5	186,7	248,9	311,2	373,4
	kcal/h	53.500	107.000	160.600	214.000	267.600	321.100
Minimum heat output G20 (80-60°C)	kW	16,8	16,8	16,8	16,8	16,8	16,8
	kcal/h	14.400	14.400	14.400	14.400	14.400	14.400
Minimum heat output G20 (50-30°C)	kW	18,2	18,2	18,2	18,2	18,2	18,2
	kcal/h	15.700	15.700	15.700	15.700	15.700	15.700
Minimum heat output G31 (80-60°C)	kW	22,4	22,4	22,4	22,4	22,4	22,4
	kcal/h	19.200	19.200	19.200	19.200	19.200	19.200
Minimum heat output G31 (50-30°C)	kW	24,3	24,3	24,3	24,3	24,3	24,3
	kcal/h	20.900	20.900	20.900	20.900	20.900	20.900
Nominal heat input	kW	58,0	116,0	174,0	232,0	290,0	348,0
	kcal/h	49.900	99.800	149.600	199.500	249.400	299.300
Minimum heat input G20	kW	17,4	17,4	17,4	17,4	17,4	17,4
	kcal/h	15.000	15.000	15.000	15.000	15.000	15.000
Minimum Minimum heat input G31	kW	23,2	23,2	23,2	23,2	23,2	23,2
	kcal/h	19.900	19.900	19.900	19.900	19.900	19.900
Min-max operating yield (80-60°C)	%	96,4-98,2	96,4-98,2	96,4-98,2	96,4-98,2	96,4-98,2	96,4-98,2
Min-max operating yield (50-30°C)	%	104,7-107,3	104,7-107,3	104,7-107,3	104,7-107,3	104,7-107,3	104,7-107,3
Operating yield at 30% (50-30°C)	%	106,4	106,4	106,4	106,4	106,4	106,4
Energy yield markings (CEE 92/42)		★★★★	★★★★	★★★★	★★★★	★★★★	★★★★
Heat modules	n°	1	1	1 de "60"+ 1 de "120"	2 de "120"	1 de "60"+ 2 de "120"	3 de "120"
NOx class		5	5	5	5	5	5
Exhaust temperat. at nominal Q. (80-60°C)	°C	68	68	68	68	68	68
Exhaust temperat. at Minimum Q. (80-60°C)	°C	58	58	58	58	58	58
Exhaust temperat. at nominal Q. (50-30°C)	°C	49	49	49	49	49	49
Exhaust temperat. at Minimum Q. (50-30°C)	°C	42	42	42	42	42	42
Maximum exhaust capacity	kg/h	95,2	190,5	285,7	380,9	476,2	571,4
CO ₂ at Q. Nominal/Minimum G20	%	9,0/9,0	9,0/9,0	9,0/9,0	9,0/9,0	9,0/9,0	9,0/9,0
CO ₂ at Q. Nominal/Minimum G31	%	10,0/10,0	10,0/10,0	10,0/10,0	10,0/10,0	10,0/10,0	10,0/10,0
Maximum pressure exhaust manifold output	Pa	100	100	100	100	100	100
Potencia eléctrica absorbida	W	198	396	594	792	990	1188
Absorbed power		IPX4D	IPX4D	IPX4D	IPX4D	IPX4D	IPX4D
CE certification	n°	1312BP4142	1312BP4142	1312BP4142	1312BP4142	1312BP4142	1312BP4142
Category		II2H3P	II2H3P	II2H3P	II2H3P	II2H3P	II2H3P
Category in France		I2E-	I2E-	I2E-	I2E-	I2E-	I2E-
Category in Belgium		I2E(S)B	I2E(S)B	I2E(S)B	I2E(S)B	I2E(S)B	I2E(S)B
Type		B23-53	B23-53	B23-53	B23-53	B23-53	B23-53
HEATING							
Max operating pressure	bar	4	4	4	4	4	4
Max operating temperature	°C	85	85	85	85	85	85
Water content modules	l	20,7	30,3	41,7	51,3	76,4	86,0
Single module temperature regulation	°C	20/80	20/80	20/80	20/80	20/80	20/80
GAS AND NOZZLE PRESSURE							
Supply pressure G20/G25	mbar	20/25	20/25	20/25	20/25	20/25	20/25
Supply pressure G31	mbar	37	37	37	37	37	37
Number of nozzles	n°	1	2	3	4	5	6
Nozzle diameter G20/G25	ø	9,3	9,3	9,3	9,3	9,3	9,3
Nozzle diameter G31	ø	6,7	6,7	6,7	6,7	6,7	6,7
Consumption at nom./min. power G20	m ³ /h	6,14/1,84	12,27/1,84	18,41/1,84	24,54/1,84	30,68/1,84	36,81/1,84
Consumption at nom./min. power G31	kg/h	4,51/1,80	9,01/1,80	13,52/1,80	18,02/1,80	22,53/1,80	27,03/1,80
WEIGHT	kg	172	282	454	564	736	846

1.4 OPERATING DIAGRAM

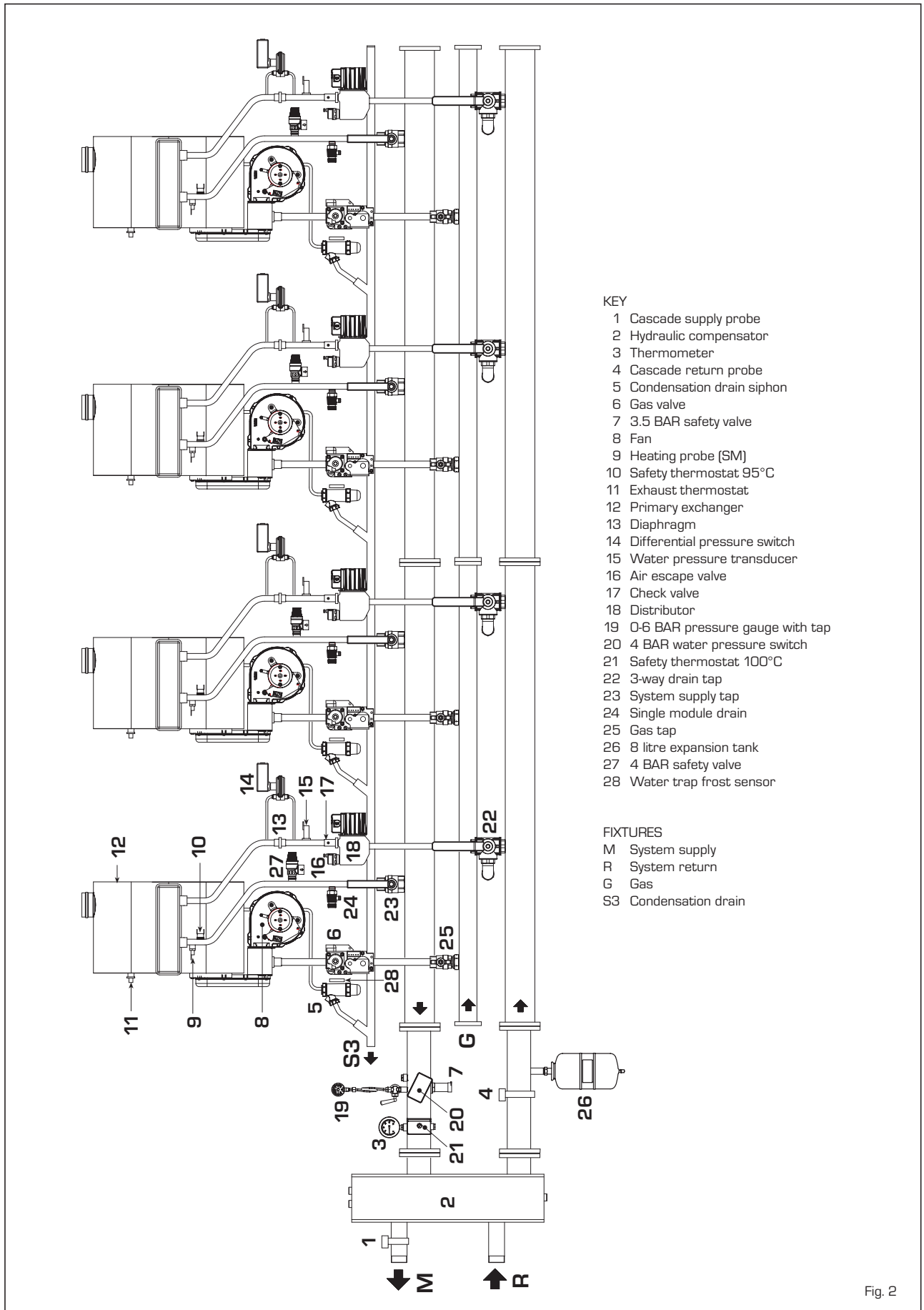

Fig. 2

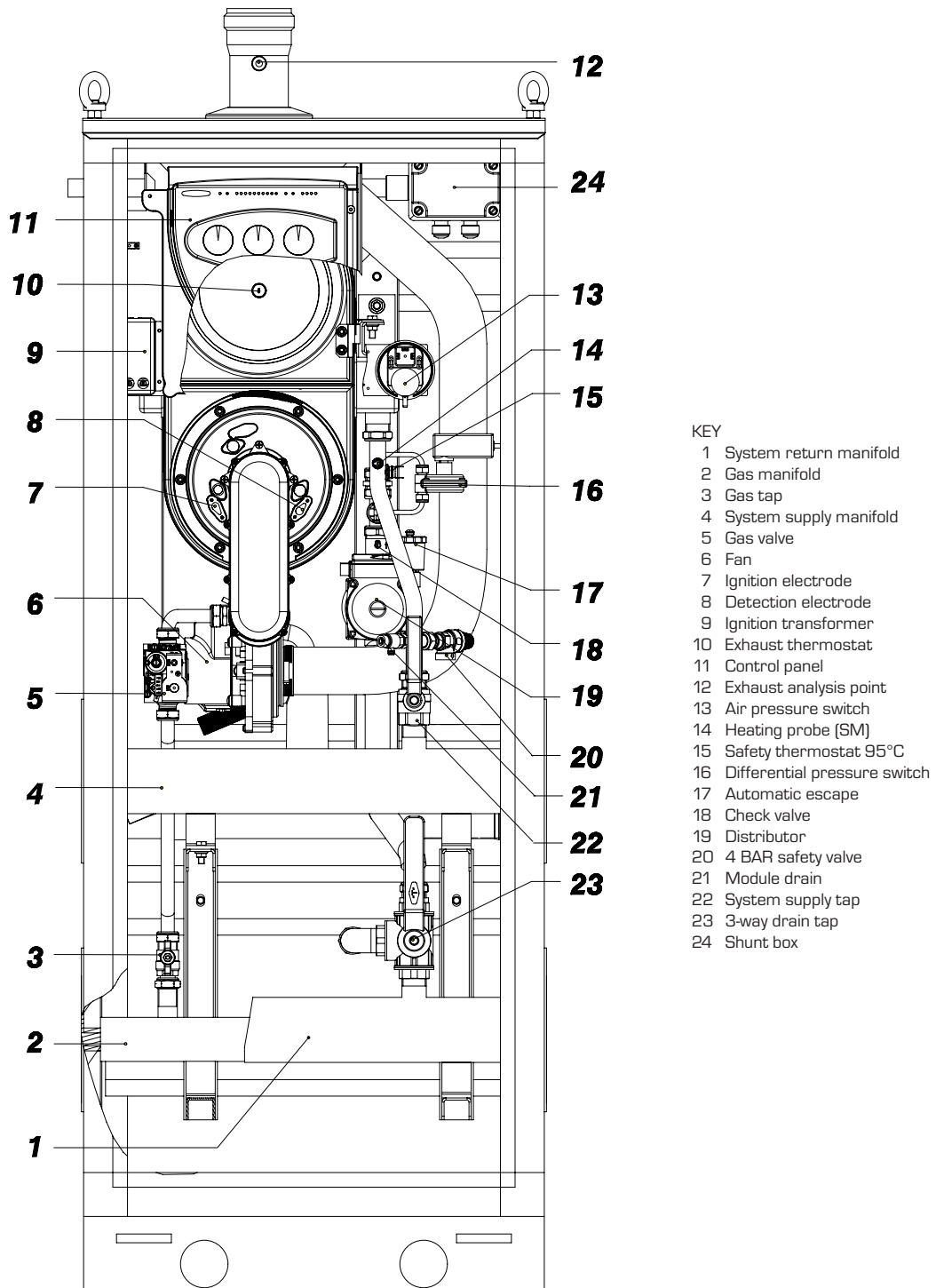

Fig. 3

2 INSTALLATION

Installation is permanent and must exclusively be performed by specialised and qualified personnel, following all the instructions and provisions included in this manual.

Current regulations must also be met.

2.1 SUPPLY

“DEWY EQUIPE 60-120 BOX” heat modules, inter-connectible by flange, are supplied with an external pre-painted zinc-coated laminate case.

They are complete with supply/return water manifold fastening screws and gaskets and sequence/cascade digestion unit cod. 8096311 supplied with “60-120-180-240 BOX” modules and cod. 8096312 supplied with “300-360 BOX” modules.

Available separately:

- Safety kit to requested according to module fixture positions:
cod. 8101511 for right-hand fixtures
cod. 8101510 for left-hand fixtures.
- Additional safety valve kit code 8103825 for modules “300-360 BOX”
- Hydraulic separator kit:
cod. 8101550 for modules “60-120-180-240 BOX”

cod. 8101551 for modules “300-360 BOX”

- Single box (size: 630 x 640 x 1600) for hydraulic separator/safety kit, code 8101517 (figure 4)
- Double box (size: 1100 x 640 x 1600) for hydraulic separator/safety kit and distributors, code 8101518
- Polypropylene exhaust manifold kit for indoor installation (purposely treated to resist weathering when installed outdoors):
cod. 8102510 for “60 BOX” module
cod. 8102511 for “120 BOX” module
cod. 8102512 for “180 BOX” module
cod. 8102513 for “240 BOX” module
cod. 8102514 for “300 BOX” module
cod. 8102515 for “360 BOX” module
- Exhaust terminal cod. 8089530 for outdoor installations.

To electrically connect the modules and to assemble the exhaust for indoor or outdoor installations, see points 2.6, 2.7 and 2.10 in this manual.

2.2 INSTALLATION

2.2.1 Indoors

“DEWY EQUIPE 60-120-180-240-300-

360 BOX” heat modules can be installed in boiler rooms whose size and requirements meet current regulations.

Furthermore, vents, with surface areas at least 3.000 sq. cm or 5.000 sq. cm for gas with density over 0.8, must be installed in the outer walls for room ventilation.

2.2.2 Outdoors

“DEWY EQUIPE 60-120-180-240-300-360 BOX” heat modules can also be installed outdoors with the specific exhaust for single module cod. 8089530.

2.3 SYSTEM CONNECTIONS

To protect the heat system from damaging corrosion, incrustation or deposits, after installation it is extremely important to clean the system using suitable products such as, for example, Sentinel X300 or X400. Complete instructions are provided with the products but, for further information, you may directly contact GE Betz.

For long-term protection against corrosion and deposits, the use of inhibitors such as Sentinel X100 is recommended after cleaning the system.

It is important to check the concentration

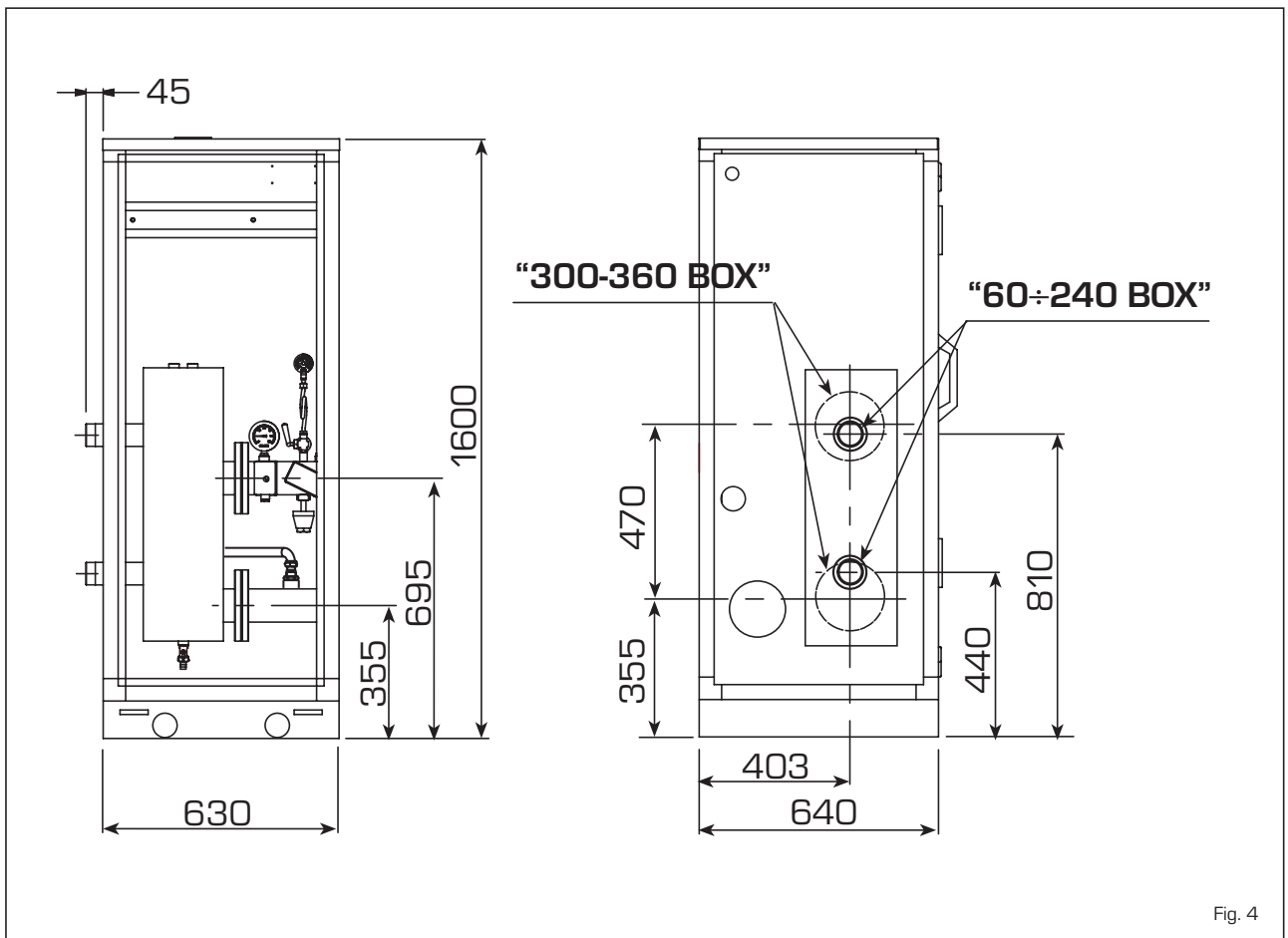

Fig. 4

of the inhibitor after each system modification and during maintenance following the manufacturer's instructions (specific tests are available at your dealer). The safety valve drain must be connected to a collection funnel to collect any discharge during interventions.

WARNING: Failure to clean the heat system or add an adequate inhibitor invalidates the device's warranty.

Gas connections must be made in accordance with current standards and regulations. When dimensioning gas pipes from the meter to the module, both capacity volume (consumption) in m^3/h and gas density must be taken into account.

System pipe sections must be able to guarantee sufficient supply to cover maximum demand, limiting pressure loss between the meter and any utility device no greater than

1.0 mbar for second family gas (natural gas).

A sticker inside the module includes identification and gas type data specific to the module.

2.3.1 Condensation drain connection

A siphoned drain must be connected to the civil drain by a pipe with minimum 5 mm per meter gradient for condensation collection.

Only normal plastic civil drain pipes are suitable to convey condensation to the building's sewer drain.

2.3.2 Filter on the gas pipe

The gas valve is supplied ex factory with an inlet filter, which, however, is not adequate to

entrap all the impurities in the gas or in gas main pipes.

To prevent malfunctioning of the valve, or in certain cases even to cut out the safety device with which the valve is equipped, install an adequate filter on the gas pipe.

2.5 FILLING THE SYSTEM

Cold system filling pressure must be 1 bar. The system must be filled slowly so that air bubbles are released through the specific escapes.

2.6 EXHAUST FOR OUTDOOR INSTALLATION

The exhaust terminal for single module cod. 8089530 is required for this type of installation. For separately supplied accessory assembly see fig. 5.

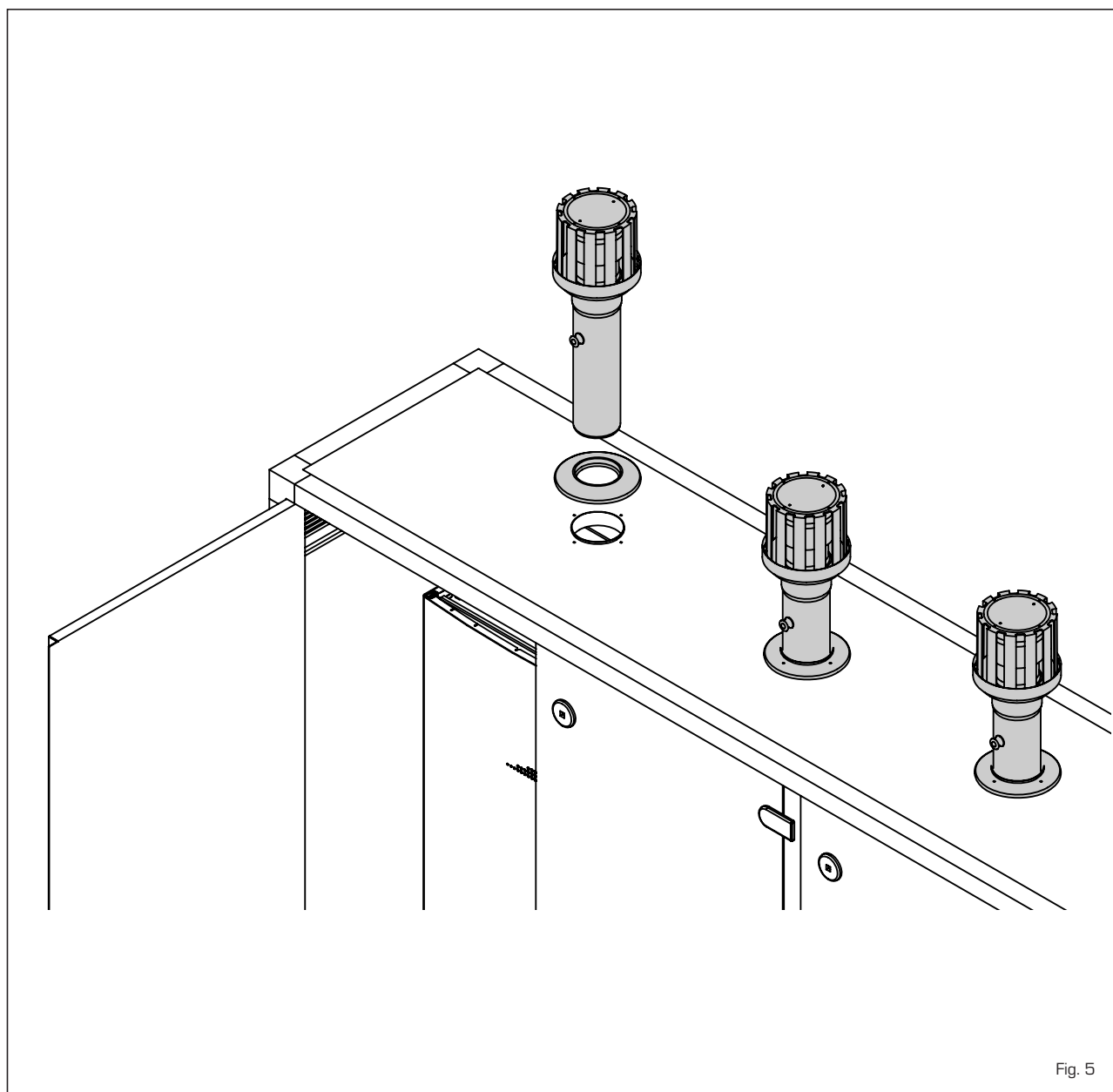

Fig. 5

**2.7 INDOOR INSTALLATION
EXHAUST KIT**

Refer to fig. 6 and 6/a-b for this type of installation.

The indicated solutions have the exhaust manifold positioned both on the module's

right and left and the use of extension cod. 8102522/23, supplied separately, is only necessary when the hydraulic separator box/safety kit cod. 8101517 is installed.

Figure 6/c for 6/d illustrates the elements included in the polypropylene exhaust manifold required for single and multiple

module installation, and the available accessories to be used according to installation type.

NOTE: The kits are purposely treated also to resist weathering when installed outdoors.

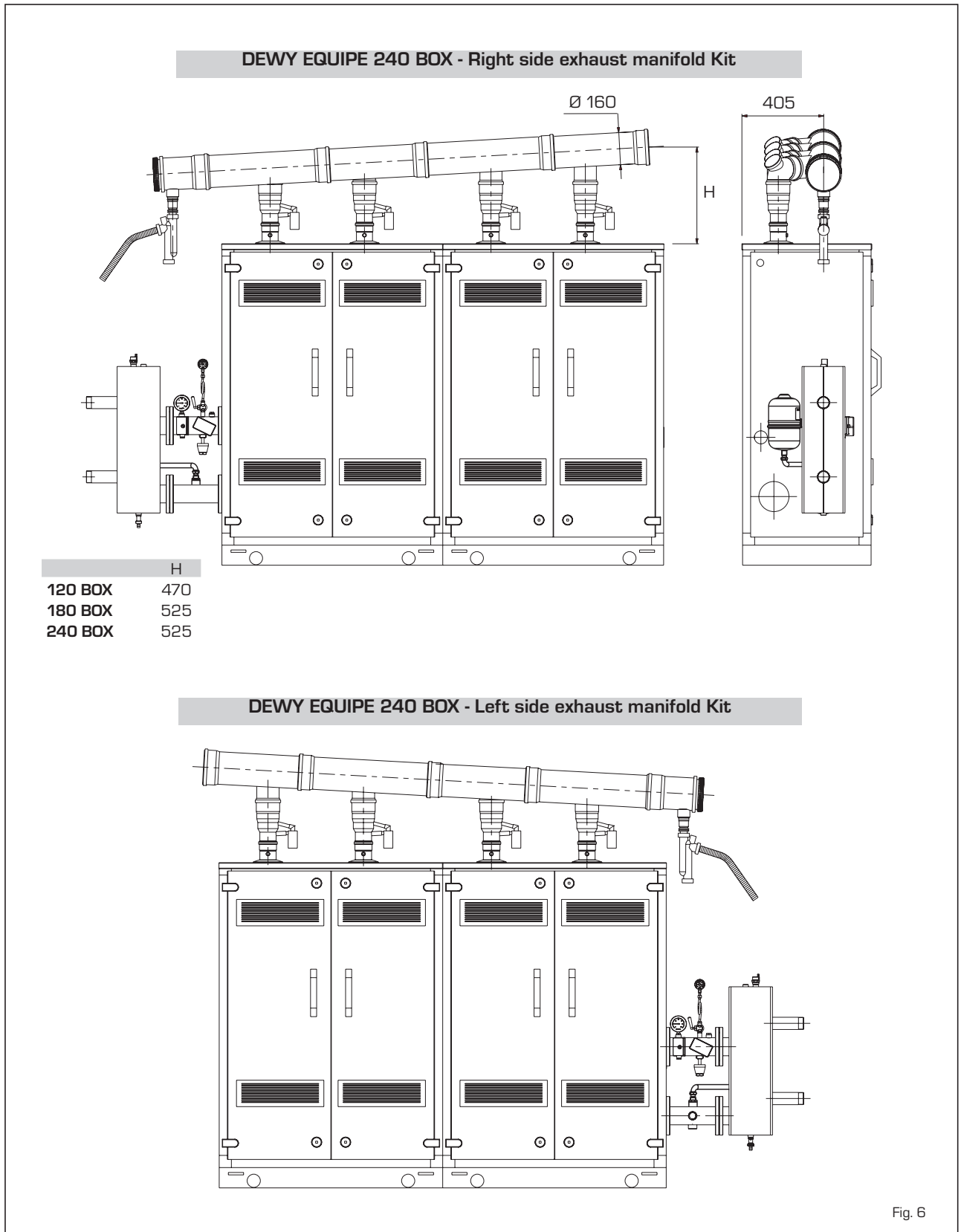
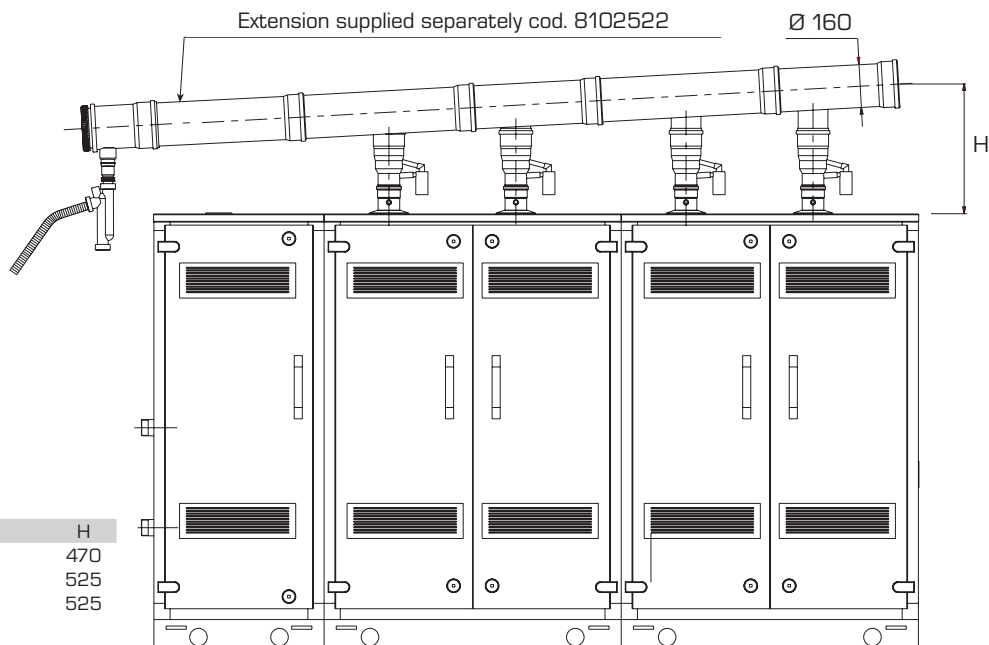

Fig. 6

DEWY EQUIPE 240 BOX - Left side exhaust manifold kit and hydraulic separator box/safety kit



	H
120 BOX	470
180 BOX	525
240 BOX	525

DEWY EQUIPE 240 BOX - Left side exhaust manifold kit and hydraulic separator box/safety kit

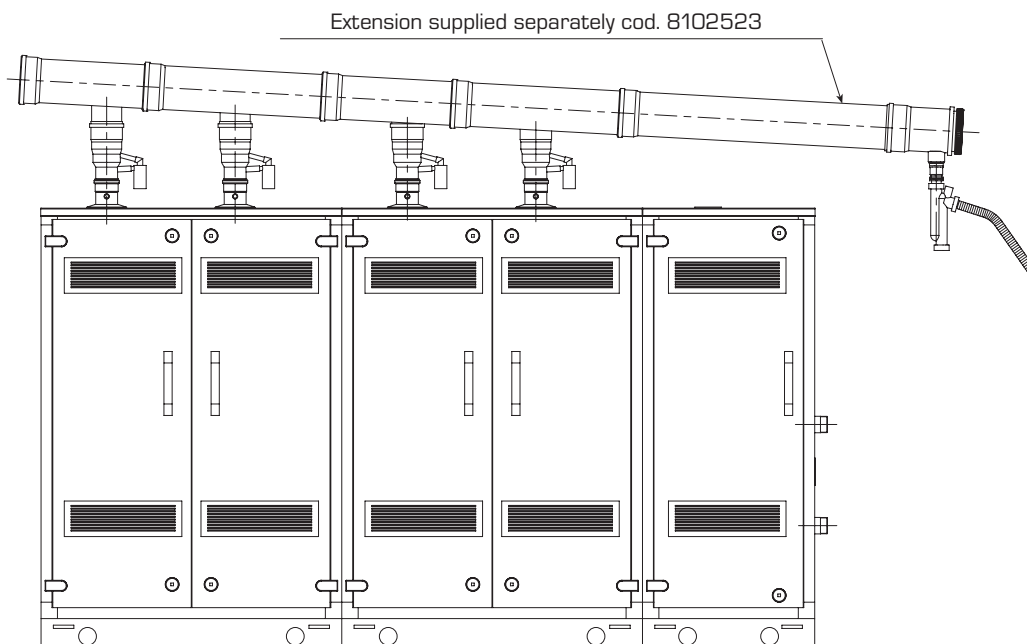
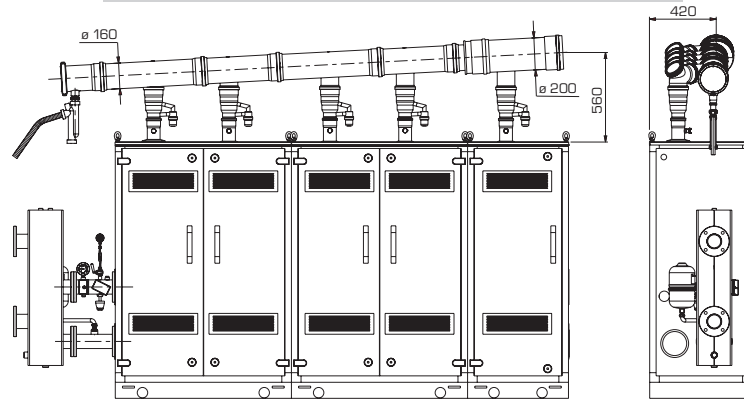
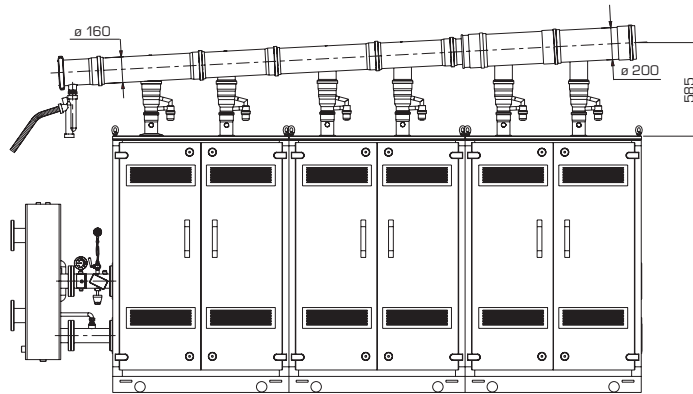

Fig. 6/a

DEWY EQUIPE 300 BOX - Right side exhaust manifold Kit



DEWY EQUIPE 360 BOX - Right side exhaust manifold Kit



DEWY EQUIPE 300 BOX - Left side exhaust manifold kit and hydraulic separator box/safety kit

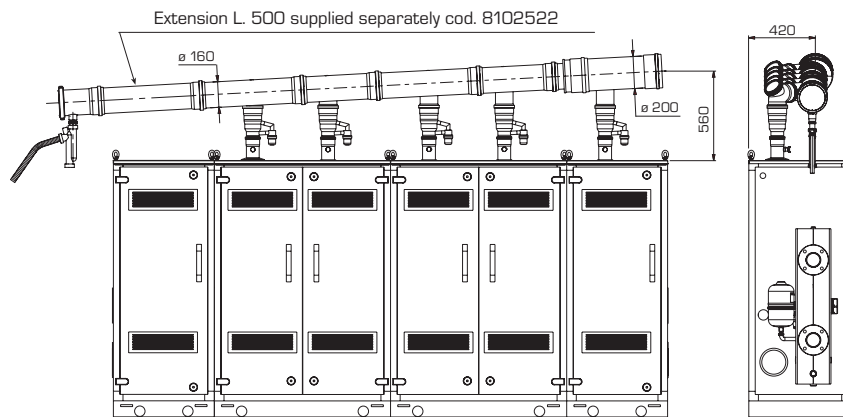

DEWY EQUIPE 360 BOX - Left side exhaust manifold kit and hydraulic separator box/safety kit

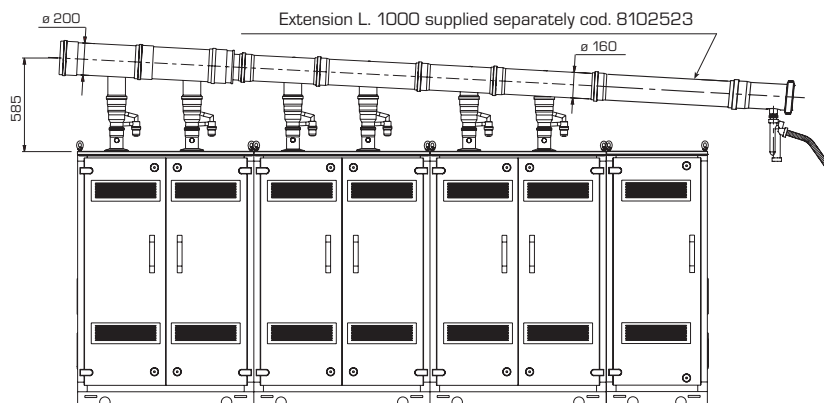
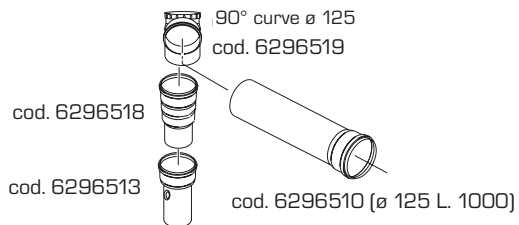
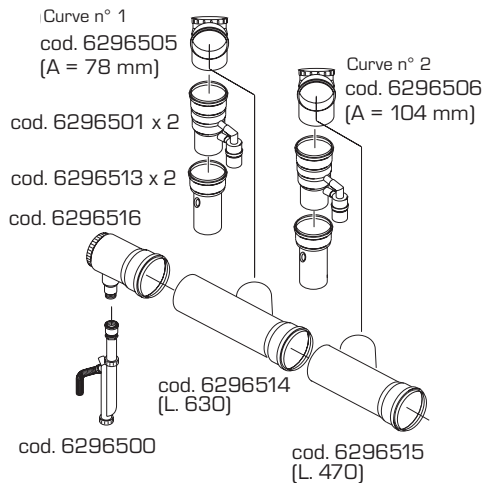

Fig. 6/b

EXHAUST MANIFOLD KIT COD. 8102510
"DEWY EQUIPE 60 BOX"



EXHAUST MANIFOLD KIT COD. 8102511
"DEWY EQUIPE 120 BOX"



EXHAUST MANIFOLD KIT COD. 8102512
"DEWY EQUIPE 180 BOX"

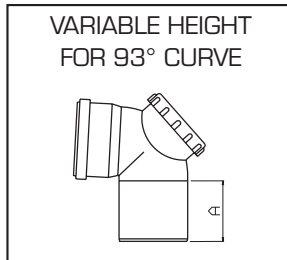
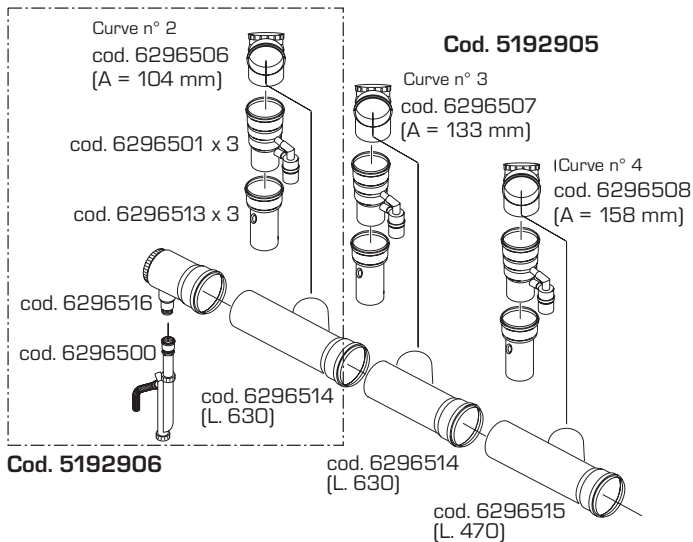

EXHAUST MANIFOLD KIT COD. 8102513
"DEWY EQUIPE 240 BOX"

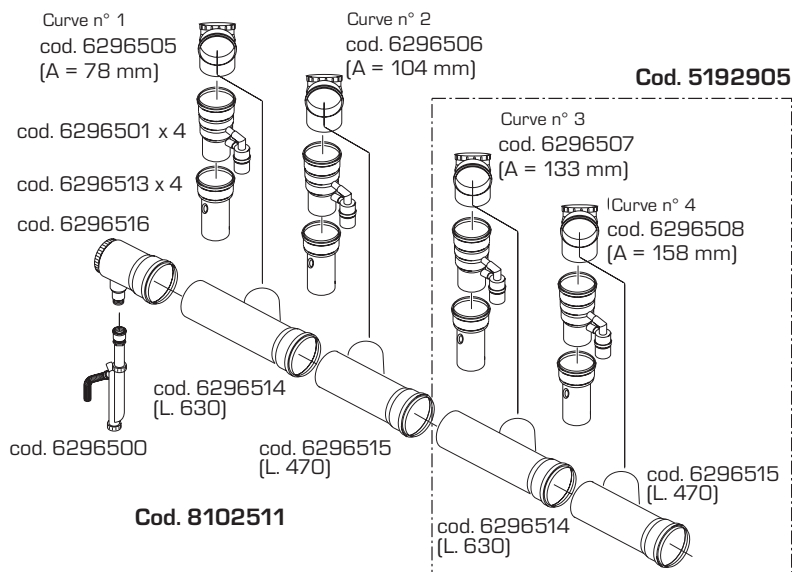

WARNING:
 To facilitate exhaust manifold component connections, spread the content of the supplied tube on the gaskets.
 Pay attention to the assembly sequence of the curves numbered with variable heights.

ACCESSORY LIST
POLYPROPYLENE ø 160
AVAILABLE OPTIONS:

- Extension L. 500 cod. 8102522
- Extension L. 1000 cod. 8102523
- 45° curve cod. 8102520
- 90° curve cod. 8102521

Fig. 6/c

SET ROOKGASVERDEELSTUK CODE 8102514
"DEWY EQUIPE 300 BOX"

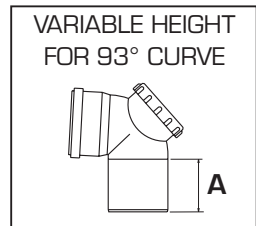
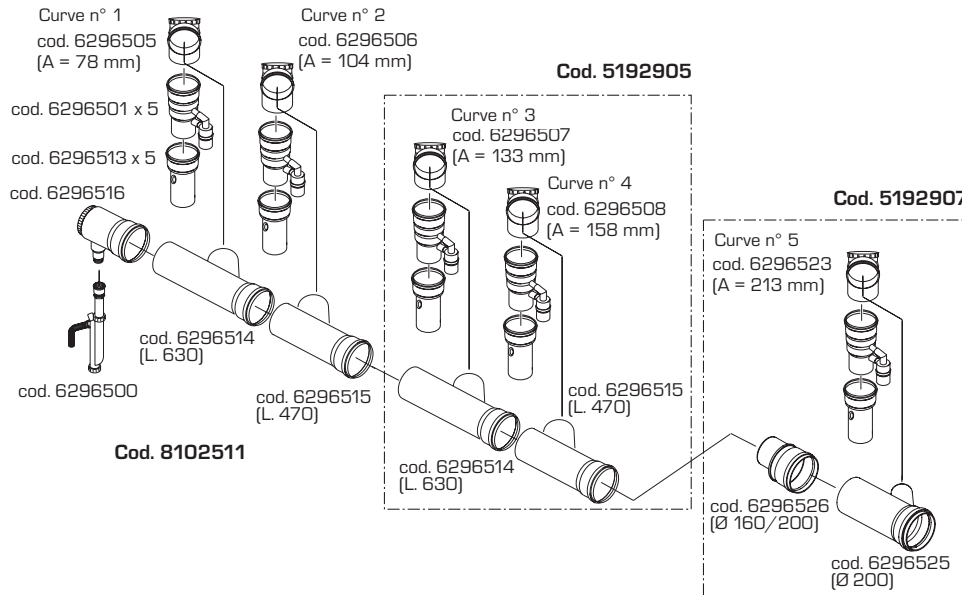

SET ROOKGASVERDEELSTUK CODE 8102515
"DEWY EQUIPE 360 BOX"

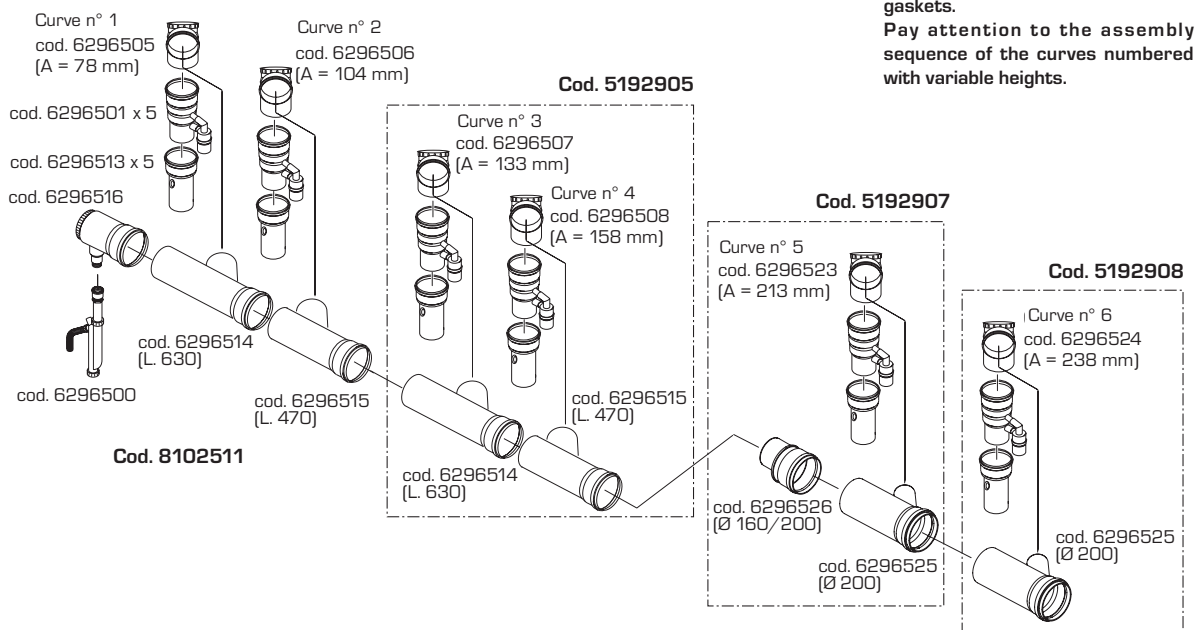

WARNING:

To facilitate exhaust manifold component connections, spread the content of the supplied tube on the gaskets.
 Pay attention to the assembly sequence of the curves numbered with variable heights.

Fig. 6/d

2.7.1 Adjustable brackets for fastening exhaust manifolds

Exhaust manifolds can be fastened with two types of brackets, which can be adjusted in height, must be ordered separately and are supplied with the necessary instructions:

- Kit with adjustable brackets for \varnothing 160 exhaust manifolds, code 8102516
- Kit with adjustable brackets for \varnothing 200 exhaust manifolds, code 8102517.

For information on the assembly and number of brackets required for each module, see figure 6/e.

2.8 SAFETY KIT

Safety kit assembly is mandatory.

According to module fixture positions, kit cod. 8101510 can be requested for left side installations and kit cod. 8101511 for right side installations.

The kit is made up of the following components (fig. 7):

- System supply flanged section:
Cod. 6291963 for left-hand fixtures
Cod. 6291964 for right-hand fixtures
- System return flanged section cod. 6291965
- Gaskets, nuts and fastening screws M16
- Thermometer 0-120°C 1/2" cod. 6146004
- 3.5 BAR safety valve cod. 6042203 and drain funnel cod. 6269402
- Safety thermostat 100°C manual reset cod. 6001409
- 4 BAR 1/4" water pressure switch cod. 6037550
- 0-6 BAR 1/4" pressure gauge cod. 6217050, tap cod. 6216606 and lock cod. 6216650
- Expansion vessel 8 liters code 6245108, connection pipe code 6227661, gaskets and nipple.

WARNING: In models "60-120-180-240 BOX" the safety kit can be inserted in a specific protective case cod. 8101512 supplied separately.

In models "300-360 BOX" safety valve code 6042203 and exhaust funnel code 6269402 must be replaced with those in the safety valve kit code 8103825 to be requested separately.

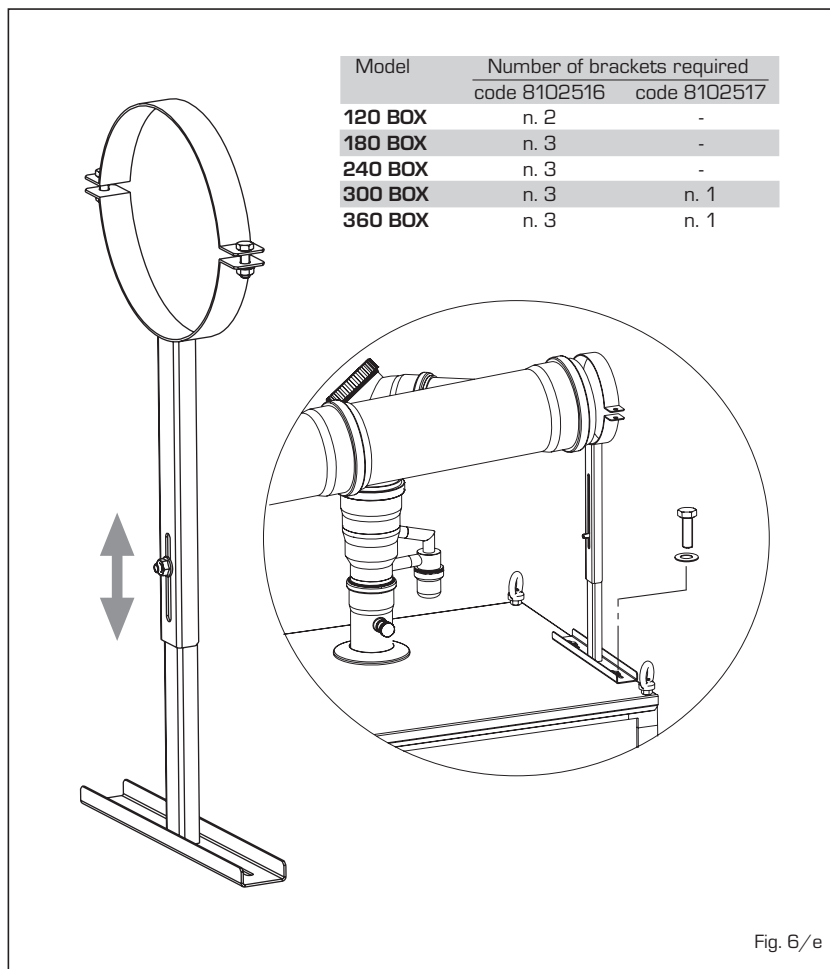

Fig. 6/e

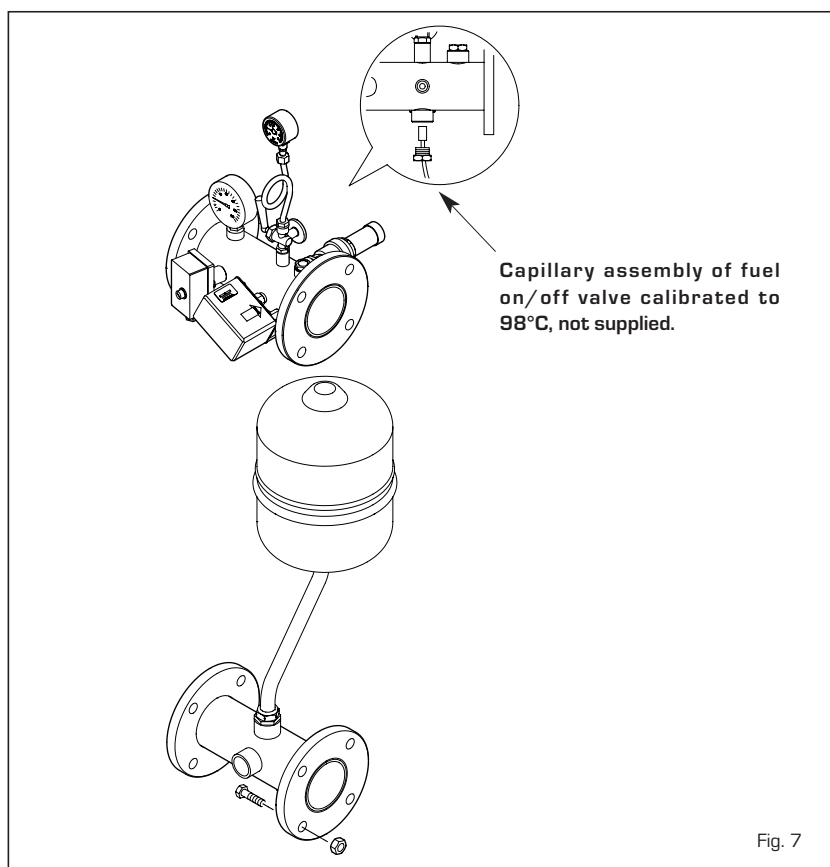

Fig. 7

2.8.1 Electrical sequence/cascade and safety kit connection (fig. 7/a)

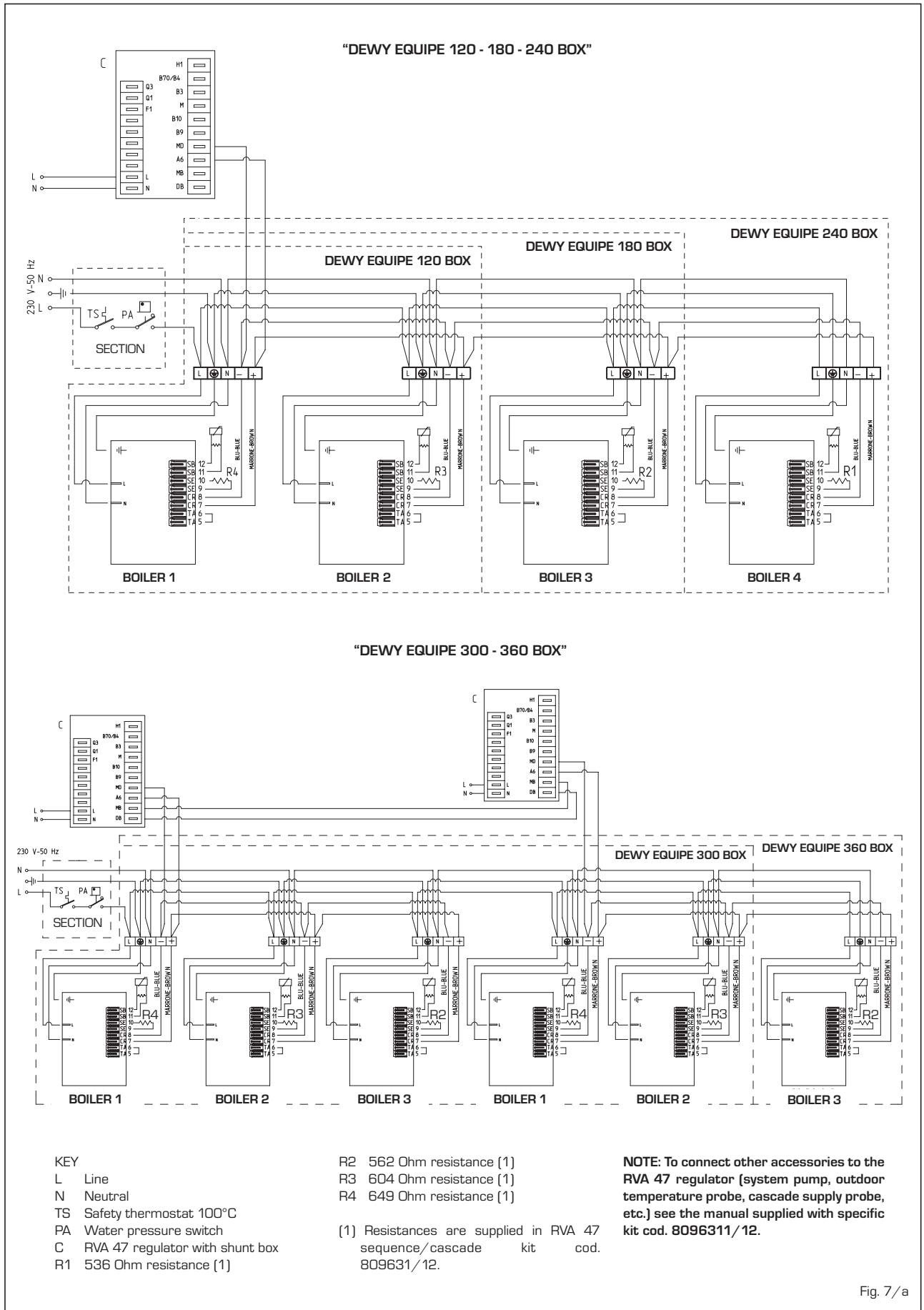

Fig. 7/a

2.9 HYDRAULIC SEPARATOR

2.9.1 DEWY EQUIPE 60-120-180-240 BOX

The hydraulic separator is supplied separately in a kit cod. 8101550 complete with gaskets, nuts and fastening screws (figure 8).

WARNING: The hydraulic separator can be inserted in a specific protective case cod. 8101517 supplied separately.

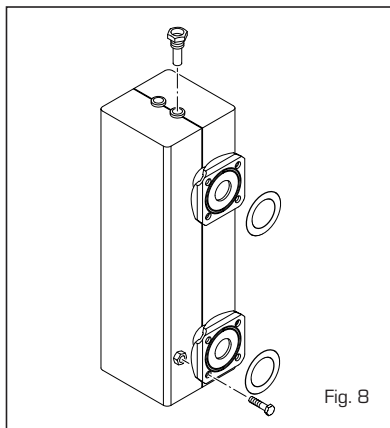

Fig. 8

2.9.2 DEWY EQUIPE 300-360 BOX

The hydraulic separator is supplied separately in a kit cod. 8101551 complete with gaskets, nuts and fastening screws (figure 8/a).

WARNING: The hydraulic separator can be inserted in a specific protective case cod. 8101517 supplied separately.

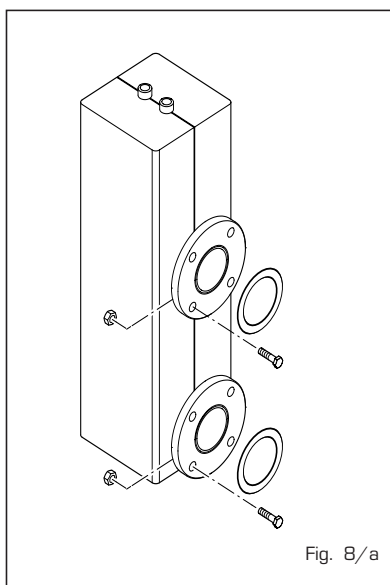
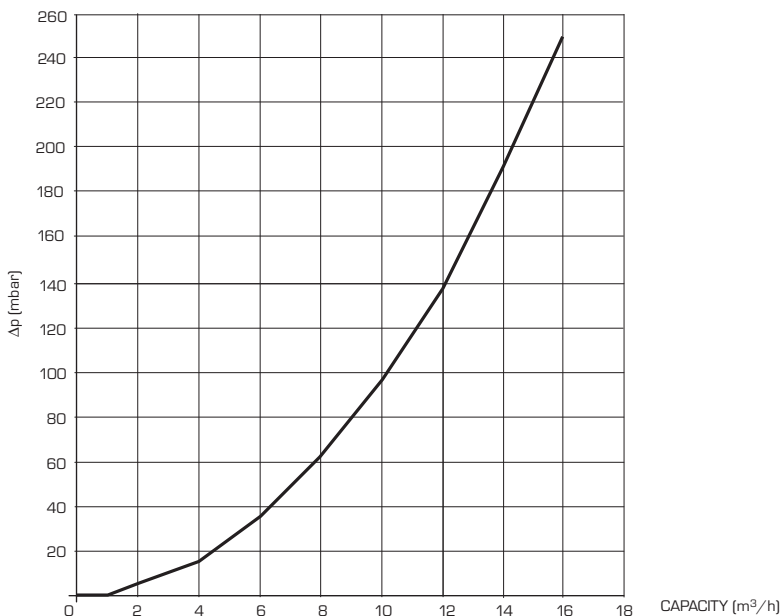

Fig. 8/a

2.9.3 Load loss

Hydraulic separator load losses are indicated in the diagram in fig. 9.

Hydraulic separator "DEWY EQUIPE 60-120-180-240 BOX"



Hydraulic separator "DEWY EQUIPE 300-360 BOX"

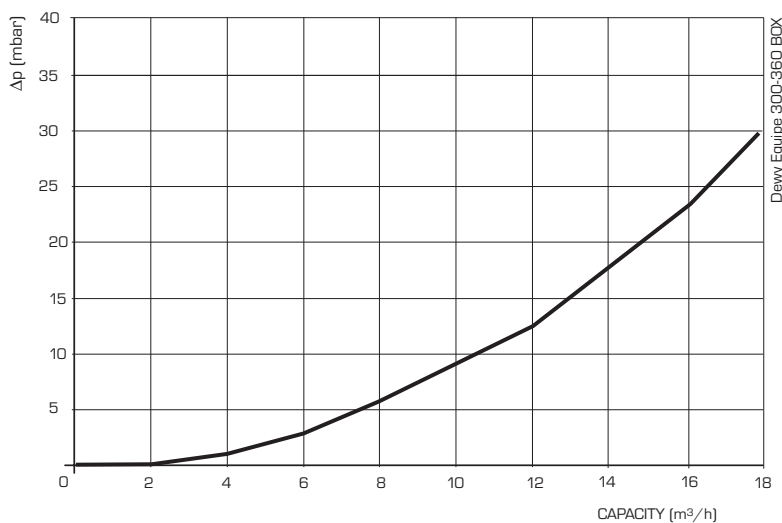

Fig. 9

2.10 ELECTRICAL CONNECTIONS

Each module is supplied with a power cord which, if replacement is required, must be

ordered from SIME.

230V - 50 Hz single phase voltage is required using a fuse protected main switch with at least 3 mm. between contacts. Observe the L - N polarity and grounding

connection.

NOTE: SIME shall not be liable for any damages to persons and things due to lack of boiler grounding.

2.10.1 "DEWY EQUIPE 60 BOX" wiring diagram

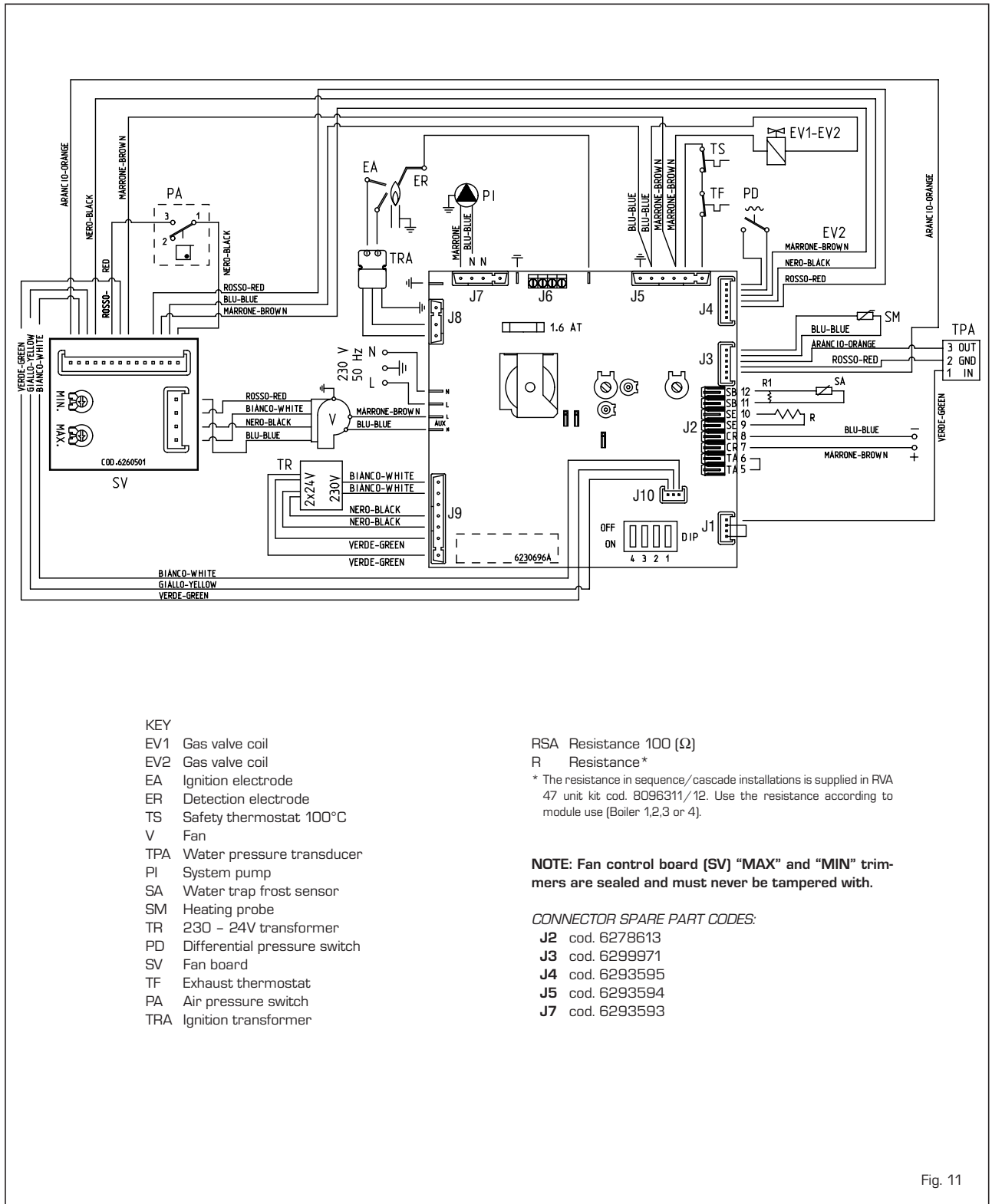
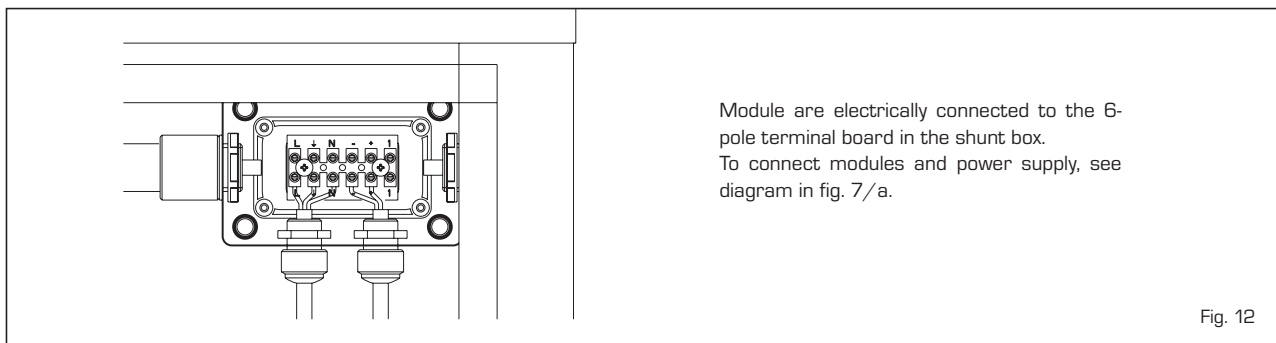
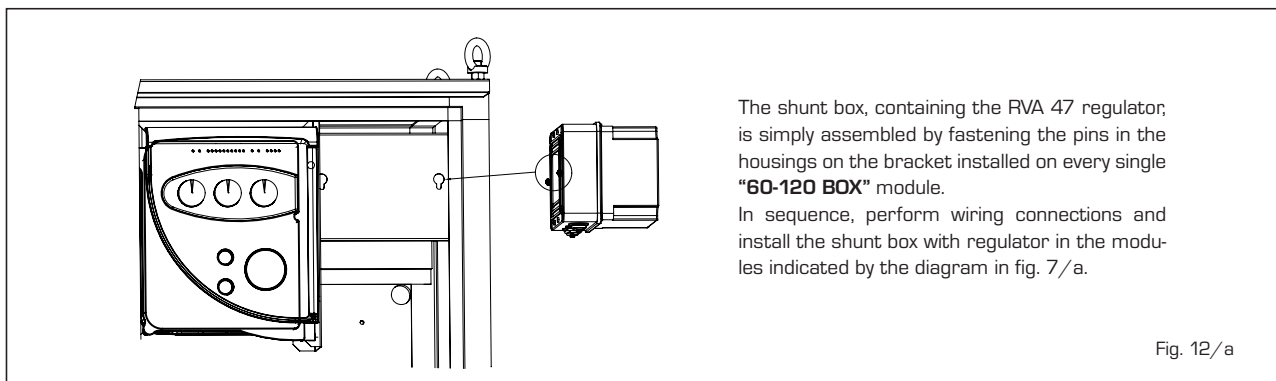

Fig. 11

2.10.2 "DEWY EQUIPE 120-180-240-300-360 BOX" sequence/cascade electrical connections



2.10.3 Installing the shunt box and cascade/sequence control unit supplied with kit code 8096311/12



3 FEATURES

3.1 ELECTRONIC BOARD

Built according to Low Voltage directive CEE 73/23 and powered at 230 Volt, via a transformer it sends 24 Volt power to the following components: gas valve, safety thermostat, heating probe, water pressure transducer and air pressure switch.

An automatic and continual modulation system permits the boiler to adjust power to the various system or user needs.

Electronic components are guaranteed to operate in a temperature range from 0 to +60°C.

3.1.1 Malfunctions

The led that signal errors and/or malfunctions are indicated in fig. 14.

3.1.2 Devices

The electronic board is equipped with the following devices:

- "POT. RISC." trimmer (10 fig. 15)
Adjusts maximum heating power.
To increase the value, rotate the trimmer clockwise, to reduce it, rotate the

trimmer counter-clockwise.

- "POT. ACC." trimmer (6 fig. 15)
Trimmer to vary the gas valve ignition pressure level (STEP). According to the type of gas the boiler is designed for, the trimmer must be adjusted to achieve a burner pressure of approximately 6.5 mm H₂O for methane gas and 9.5 mm H₂O for propane gas (G31).
To increase pressure, rotate the trimmer clockwise, to reduce it, rotate the trimmer counter-clockwise. The slow ignition pressure level can be set during the first five seconds after the burner is lit.

After setting the ignition pressure level (STEP) according to the type of gas, make sure that the heating gas pressure is still the previously set value.

- "ANN. RIT." connector (5 fig. 15)
The electronic board is programmed, during heating, with a technical burner delay of about 90 seconds that is performed both at cold start and subsequent ignitions. This is to prevent rapid ignitions and shutdowns that could, in particular, occur in systems with high load losses. Each time the boiler restarts, after the slow ignition, for about 1 minute it will run

at minimum modulation pressure before moving to the set heating pressure. The addition of a bridge will cancel both the programmed technical delay and the minimum pressure operating period at ignition. In this case, the time between shutdown and the next ignition will depend on a 5°C differential detected by the heating probe (SM).

- DIP SWITCH (13 fig. 15)
For correct module operations, the dip switches must be positioned as indicated below:

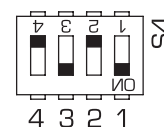

- "Modureg Sel." connector (14 fig. 15)
The bridge must always be **connected**.
- "Albatros" connector (15 fig. 15)
The bridge must always be **off**.
It is only engaged in sequence/cascade installations with several boilers.

WARNING: All the above operations must be performed by authorised personnel, otherwise the warranty shall be invalidated.

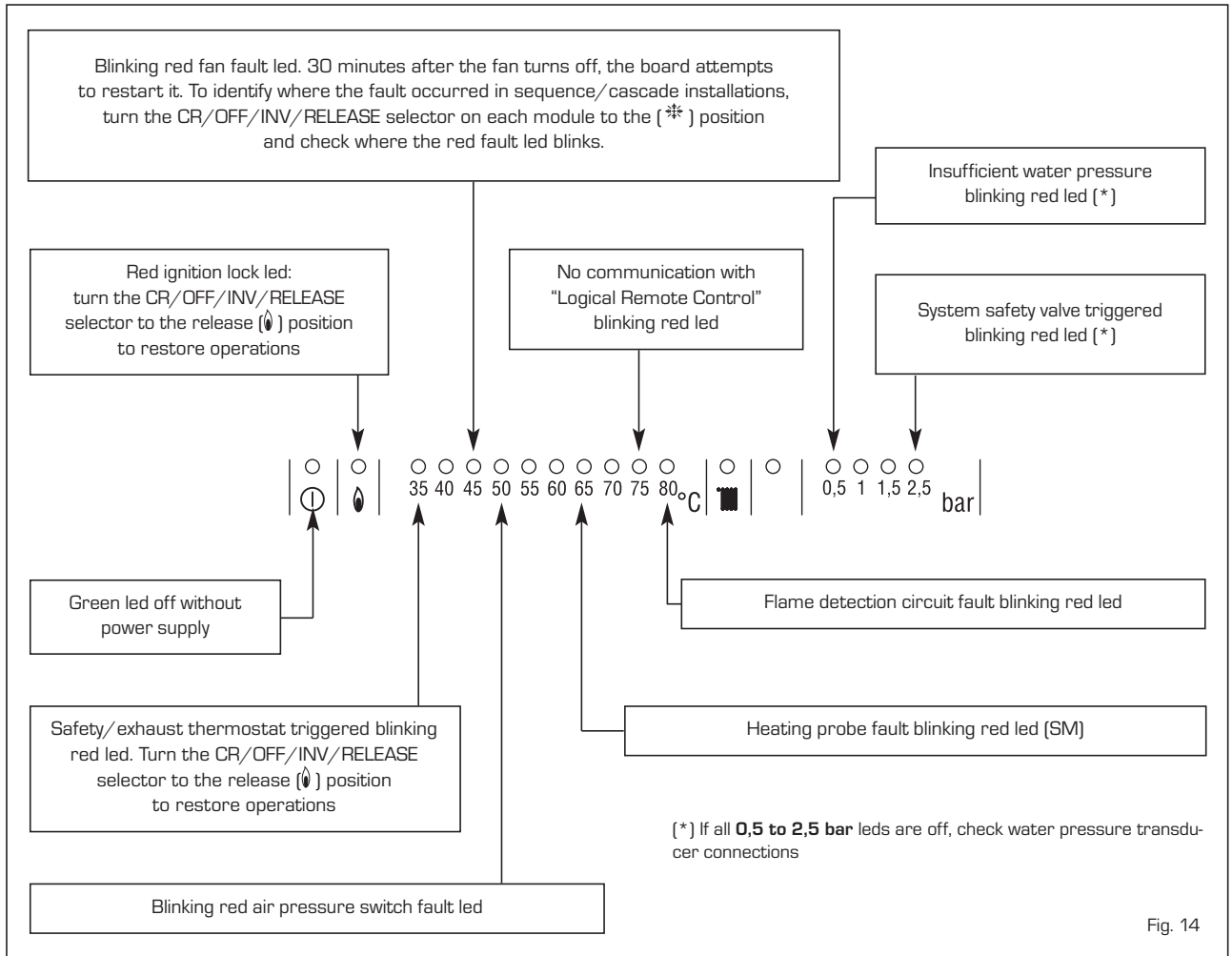

Fig. 14

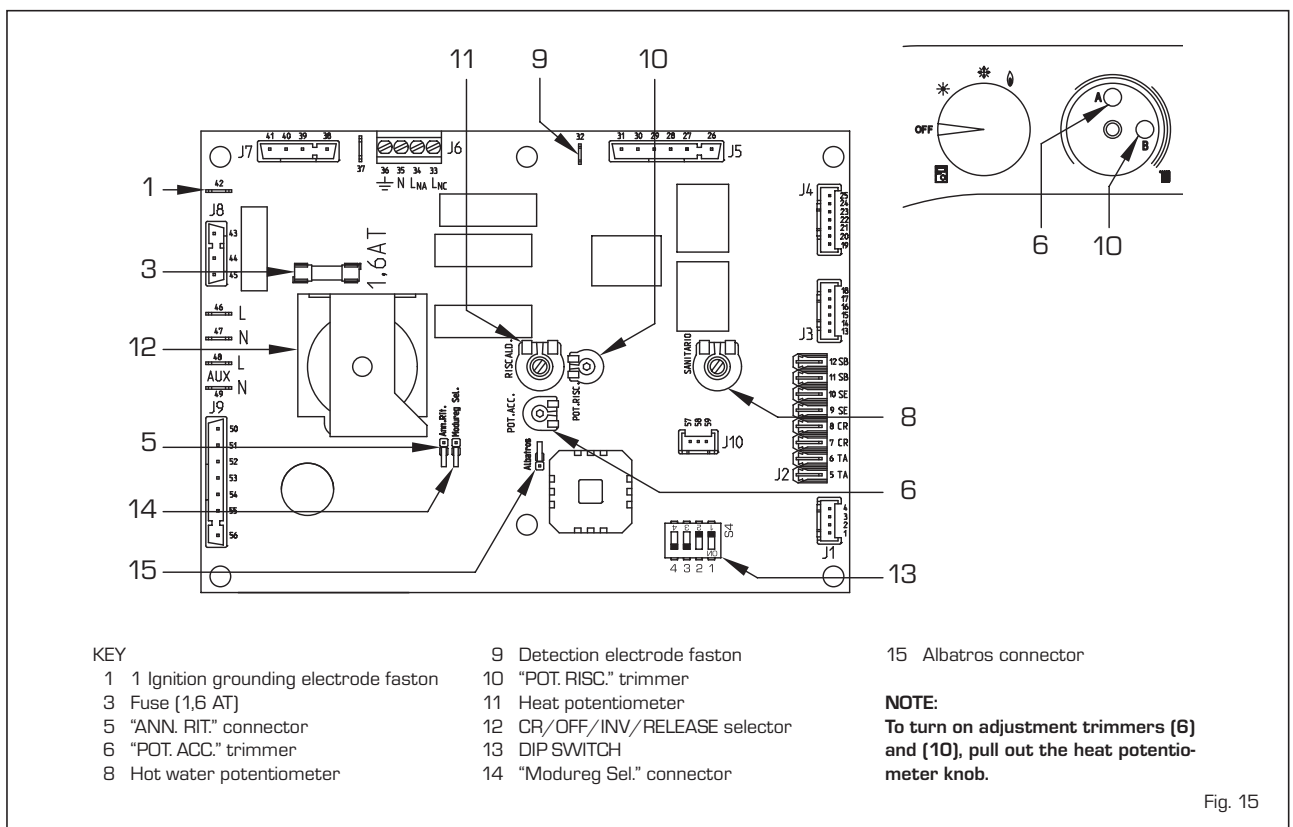

Fig. 15

3.2 TEMPERATURE PROBE AND WATER PRESSURE TRANSDUCER

Antifreeze system made up of the NTC heating sensor that activates when the water temperature reaches 6°C. **Tables 1 - 1/a** include the resistance values (Ω) that are obtained on the valve when the temperature changes and those on the transducer when pressure changes.

The module does not work when the heating probe (SM) is cut off.

TABLE 1 (Probe)

Temperature (°C)	Resistance (Ω)
20	12.090
30	8.313
40	5.828
50	4.161
60	3.021
70	2.229
80	1.669

TABLE 1/a (Transducer)

Pressure (bar)	Resistance (Ω)	
	min.	max.
0	297	320
0,5	260	269
1	222	228
1,5	195	200
2	167	173
2,5	137	143
3	108	113
3,5	90	94

3.3 ELECTRONIC IGNITION

Flame detection ignition is controlled by two electrodes that guarantee maximum safety with intervention time, for accidental shut-downs or no gas, within 1 second.

3.3.1 Operating cycle

Rotate the selector to summer or winter and check the green led (①) to make sure power is on. The burner should ignite within max. 10 seconds. Failed ignition consequently lighting the appliance block signal may occur due to the following:

- Ignition electrode does not spark

Only gas is supplied to the boiler and, after 10 sec., the block led turns on.

It may be caused by the fact that the electrode is cut-off or is not secured in the ignition transformer terminal.

- No flame detection

At ignition, the electrode continues to spark even though the burner is on. After 10 sec. it stops sparking, the burner turns off and the block led turns on.

The detection electrode wire is cut-off or the electrode is grounded; the electrode is worn and requires replacement. The electronic board is defective.

A sudden blackout immediately turned off

the burner, when power is restored, the boiler will automatically start.

3.4 AIR PRESSURE SWITCH

The pressure switch signal value is measured by a specific tool connected to the positive and negative pressure fixtures.

The pressure switch is factory set to 35-45 Pa.

3.5 AREA SYSTEM ELECTRICAL CONNECTIONS

For the "DEWY EQUIPE 60 BOX" heat module use a separate electrical line where the room thermostats with relevant area valves or pumps must be connected.

Switch or relay contacts must be connected to the electronic board connector [J2] after removing the existent bridge (fig. 17).

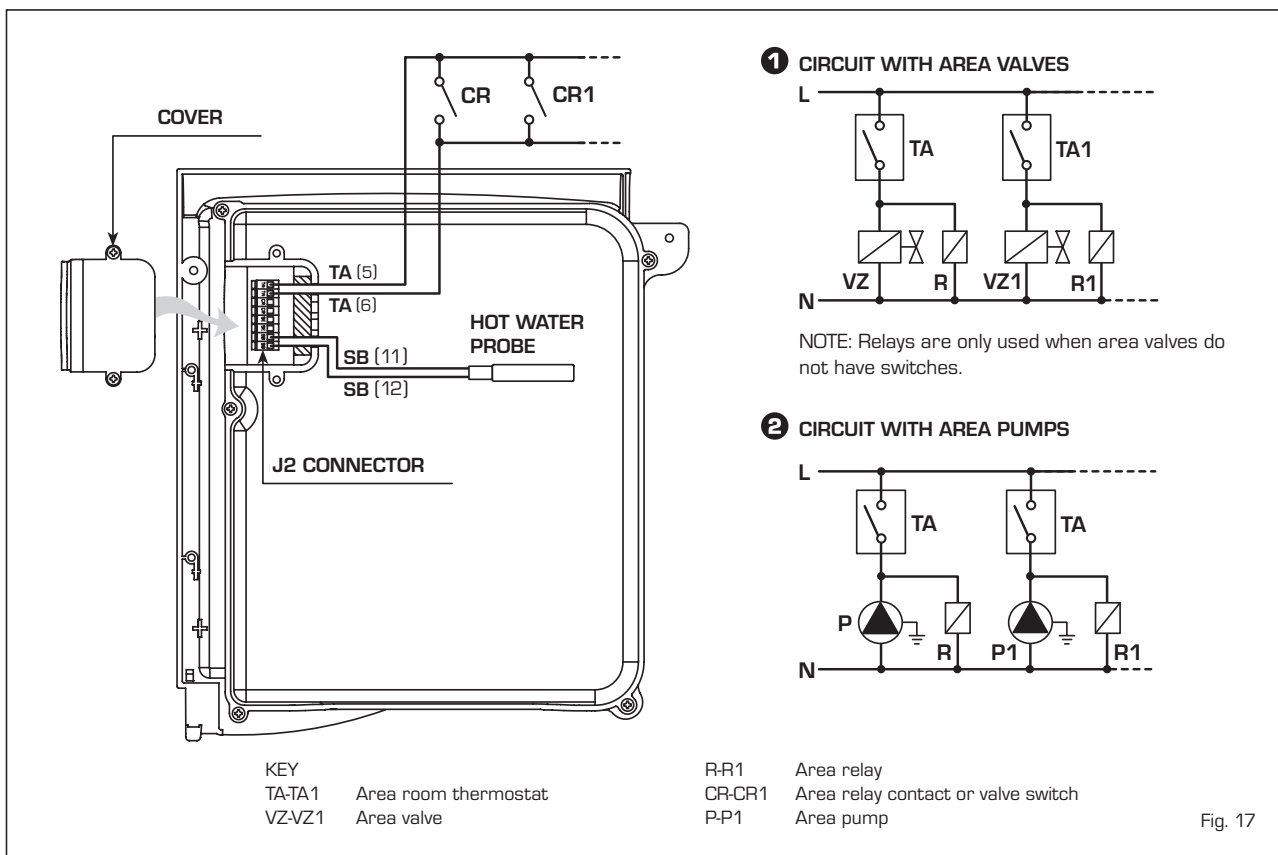

4 USE AND MAINTENANCE

4.1 GAS VALVE

Each single module is mass produced with gas valve model SIT 848 SIGMA (fig. 18).

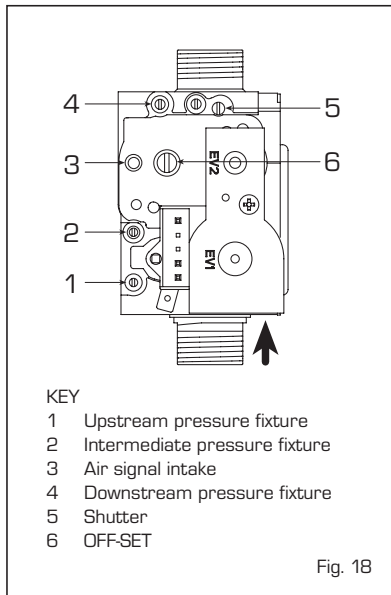

4.2 SINGLE MODULE HEAT POWER ADJUSTMENT

To adjust heating power by changing the

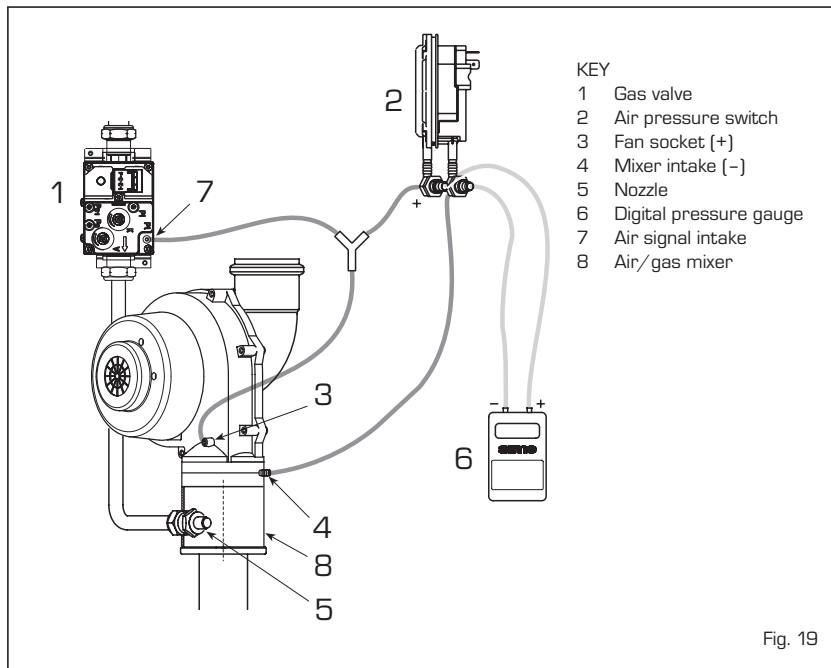

58 kW factory setting, use a screwdriver on the heat power trimmer (10 fig. 15). To increase operating pressure, rotate the trimmer clockwise, to reduce it, rotate the trimmer counter-clockwise.

Single module power settings can be checked by observing the hour-counter

and comparing its value to **Table 2 - 2/a**; or "Δp air" can be measured with a digital pressure gauge connected as indicated in fig. 19.

The values must be compared with those in **Tablas 2 - 2/a**.

TABLE 2 - G20

Variable heat power		Δp air *		Gas flow**
(80-60°C)	(50-30°C)	(80-60°C)	(50-30°C)	
kW	kW	mm H ₂ O	mm H ₂ O	m ³ /h
16,8	18,2	6,6	6,7	1,84
26,4	28,7	9,7	9,9	2,89
36,9	40,2	19,8	20,5	4,01
47,4	51,7	36,8	38,3	5,13
57,0	62,2	58,2	60,7	6,14

* "Δp air" is measured with the boiler on using a differential pressure gauge connected to the fan sockets.

** Gas flow is referred to lower heat strength in standard 15°C and 1013 mbar conditions.

TABLE 2/a - G31

Variable heat power		Δp air *		Gas flow**
(80-60°C)	(50-30°C)	(80-60°C)	(50-30°C)	
kW	kW	mm H ₂ O	mm H ₂ O	kg/h
22,4	24,3	10,2	10,9	0,95
26,2	28,5	10,8	11,5	1,11
36,7	39,9	19,1	19,6	1,54
47,3	51,6	36,9	36,8	1,98
57,0	62,2	61,1	60,2	2,37

* "Δp air" is measured with the boiler on using a differential pressure gauge connected to the fan sockets.

** Gas flow is referred to lower heat strength in standard 15°C and 1013 mbar conditions.

4.3 SINGLE MODULE CALIBRATIONS

GAS CONVERSION

- Close the gas cock.
- Replace the injector (pos. 30) and the relevant gasket (pos. 45).
- Cut the specified resistance on the fan control board.
- Test for soundness all the gas

connections using soapy water or appropriate products.
DO NOT USE NAKED FLAMES.
 - Stick onto the casing panel the plate showing the relevant feeding gas.
 - Proceed with air and gas calibration as described below.

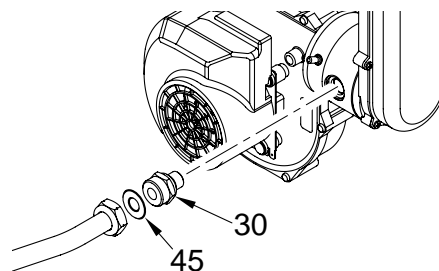

Single modules are calibrated in heating position.

"Δp air" ADJUSTMENT

To measure "Δp air" simply connect the differential pressure gauge, equipped with a decimal scale in mm or Pascal, to the positive and negative sockets on the air pressure switch (Drawing 1).

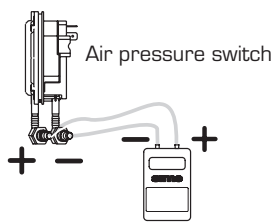

Drawing 1

Operating sequence:

- 1) Rotate the module heating power adjustment trimmer clockwise to the limit (B - Drawing 2); fan on maximum.
- 2) Find the "max Δp air" values in the table, using the fan board "MAX" trimmer (Drawing 3);

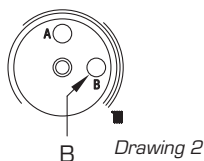

Drawing 2

Max. Δp air

Single module	
Met. (G20)	66,4
Prop. (G31)	73,6

- 3) Rotate the module heating power adjustment trimmer counter-clockwise to the limit (B - Drawing 2); fan on minimum.

- 4) Find the "min Δp air" values in the table, using the fan board "MIN" trimmer (Drawing 3);

Min. Δp air

Single module	
Met. (G20)	7,1
Prop. (G31)	12,0

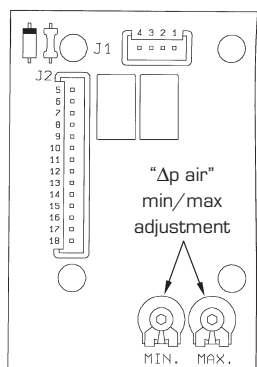

Drawing 3

"Δp air-gas" ADJUSTMENT

To measure "Δp air-gas" simply connect the positive socket on the differential pressure gauge to the valve gas intake and the negative socket to the air pressure switch (Drawing 4).

Gas pressure is always adjusted with the fan on minimum.

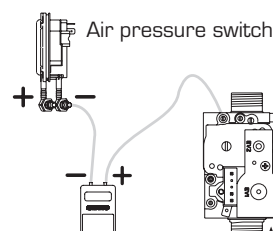

Drawing 4

Operating sequence:

- 1) Rotate the module heating power adjustment trimmer counter-clockwise to the limit (B - Drawing 5); fan on minimum.
- 2) Completely unscrew the valve gas shutter (1 - Drawing 6);

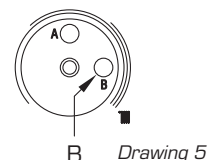

Drawing 5

- 3) Use the gas valve OFF-SET adjustment screw (2 - Drawing 6) and find the "Δp air-gas" value in the table.

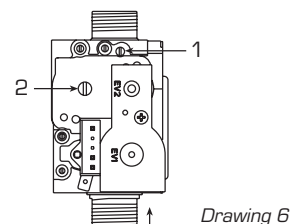

Drawing 6

Shutter open

Single module	
Methane (G20)	5,8
Propane (G31)	10,8

- 4) Use the shutter (1 - Drawing 6) and find the "Δp air-gas" value in the table:

Adjusted shutter

Single module	
Methane (G20)	5,0
Propane (G31)	9,8

After calibrations, check the CO₂ values with a combustion analyser. If they deviate more than 0.2 from the table values, the following corrections must be made:

	CO ₂	
	Methane (G20)	Propane (G31)
"MIN" Power	9,0	10,0
"MAX" Power	9,0	10,0

- To correct CO₂ to the "MIN" power, use the OFF-SET screw (2 - Drawing 6).
- To correct CO₂ to the "MAX" power, use the shutter (1 - Drawing 6).

GB - 04/05

Fig. 20

4.4 CLEANING AND MAINTENANCE

Scheduled generator maintenance must be performed annually by authorised technicians.

4.4.1 Chimney sweep function

To check single module combustion, rotate the selector to position (🔥) until the yellow led (🟡) starts to blink (fig. 21).

At this time the module will start to heat at maximum power and turn off at 80°C, restarting at 70°C.

Before starting the chimney sweep function, make sure the radiator valves or any other area valves are open.

After checking combustion, turn off the module by rotating the selector to (OFF); return the selector to the required function.

WARNING:

After about 15 minutes the chimney sweep function automatically turns off.

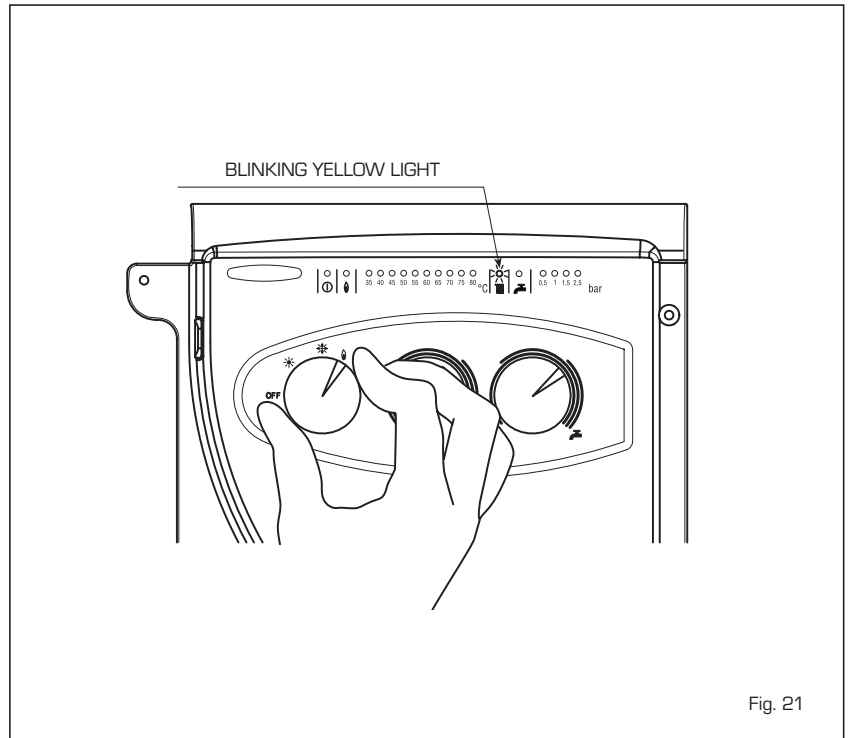

Fig. 21

WARNINGS

- In the event of appliance fault or malfunctions, turn it off and do not attempt to directly repair it. Only contact authorised technicians.
- Generator installation and any other service or maintenance must be performed by qualified personnel. It is strictly forbidden to tamper with devices sealed by the manufacturer.
- It is strictly forbidden to obstruct the vents and room vents where the appliance is installed.

IGNITION AND OPERATIONS

“DEWY EQUIPE 60 BOX” SINGLE MODULE IGNITION (fig. 1)

Open the gas tap and turn on the module by rotating the selector knob to winter (❄️).

The green led (⓪) turn on to indicate that power is on.

The generator, once the temperature set on the potentiometer is reached, will start automatic operations to provide the system with the required power.

“DEWY EQUIPE 60 BOX” SINGLE MODULE SHUTDOWN (fig. 1)

To turn off the generator, turn the selector knob to (OFF).

For prolonged periods of disuse, disconnect the power supply, close the gas tap and, in the event of low temperatures, empty the generator and hydraulic system to prevent pipes from bursting due to frozen water.

“DEWY EQUIPE 60 BOX” SINGLE MODULE ADJUSTMENT (fig. 2)

Heating temperature is adjusted using the heating knob (⌘).

The set temperature is indicated on the red led scale from 35÷80°C and the yellow heating led (⌘) turns on simultaneously.

If the water return temperature is lower than about 55° C, combustion product condensates further increasing heat exchange efficiency.

GAS TRANSFORMATION

Only contact authorised technicians if transformation to another gas is required.

CLEANING AND MAINTENANCE

Scheduled generator maintenance must be performed annually by authorised

technicians.

The boiler is supplied with a power cord which, if replacement is required, must be ordered from SIME.

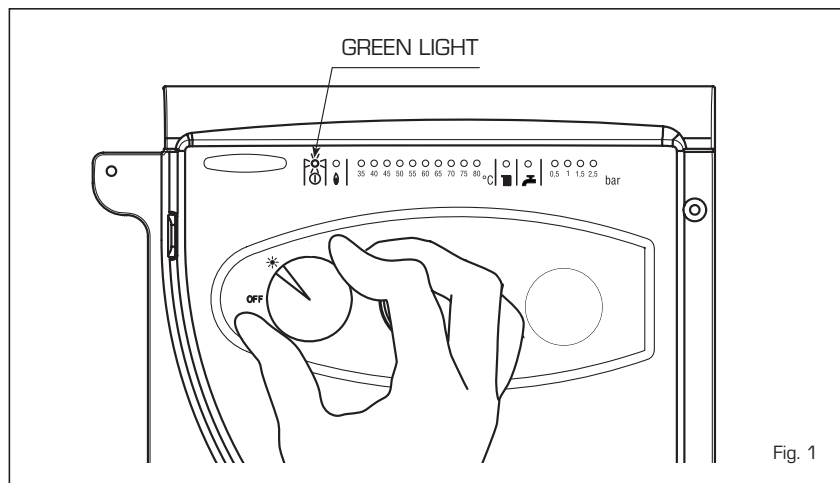

Fig. 1

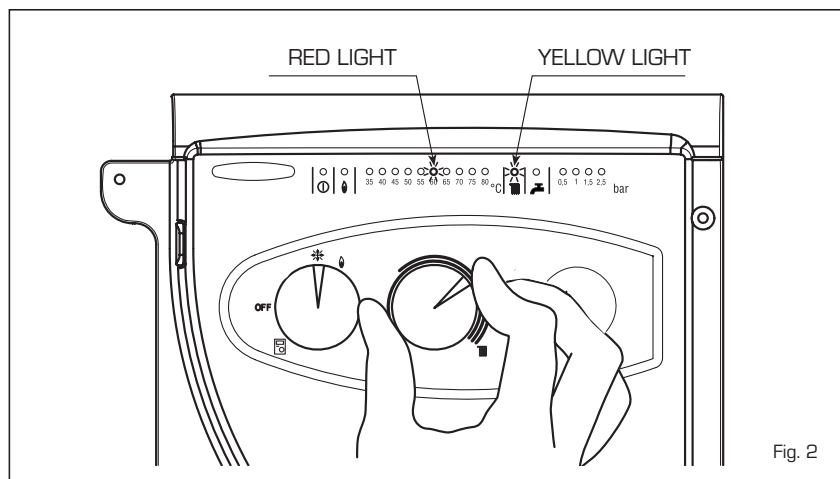

Fig. 2

**“DEWY EQUIPE 60 BOX”
SINGLE MODULE MALFUNCTIONS**

- **Ignition lock** (fig. 3)
If the burner does not light the red led (☹) turns on. To attempt ignition again, rotate the selector knob to (☹) and release it immediately after returning it to winter operations (❄).
If it locks again, request an authorised service control.

- **Insufficient water pressure** (fig. 4)
If the “0.5 bar” red light blinks, the module does not work. To restore operations, fill the system until the green “1 bar” led turns on. If all leds are off, request an authorised service call.

- **Safety/exhaust thermostat triggered** (fig. 5)
If the safety/exhaust thermostat triggers the red “35°C” led blinks.
To attempt ignition again, rotate the selector knob to (☹) and release it immediately after returning it to winter operations (❄).
If it locks again, request an authorised service control.

- **Other faults** (fig. 6)
When one of the red “40÷80°C” leds blinks, turn off the generator and attempt ignition again.
This operation can be repeated 2-3 times at most, in the event of failure, request an authorised service call.

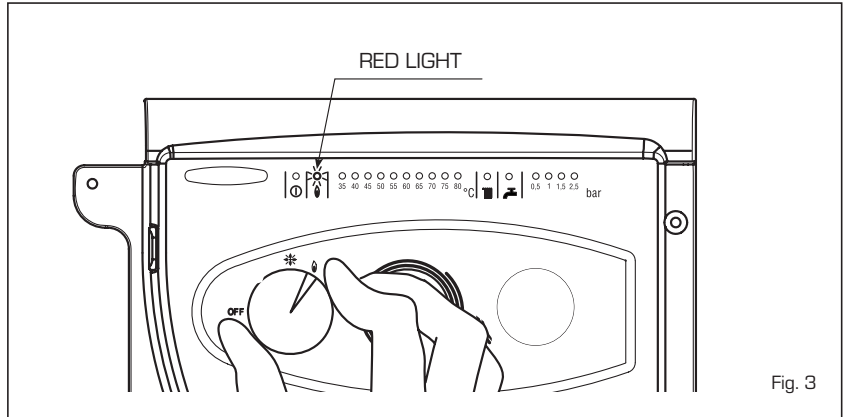

Fig. 3

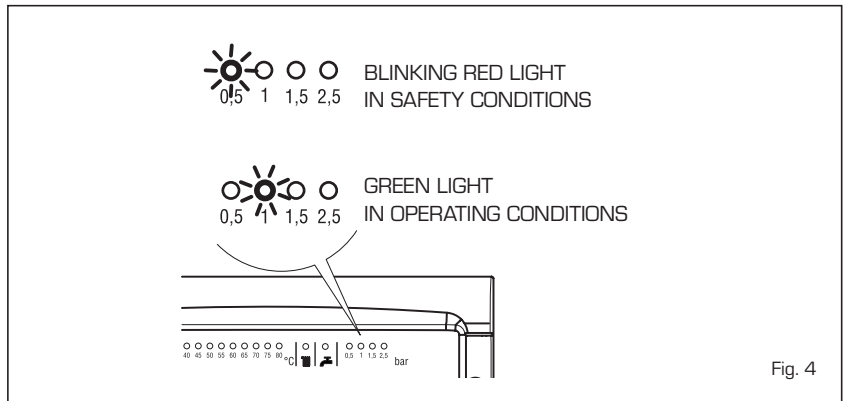

Fig. 4

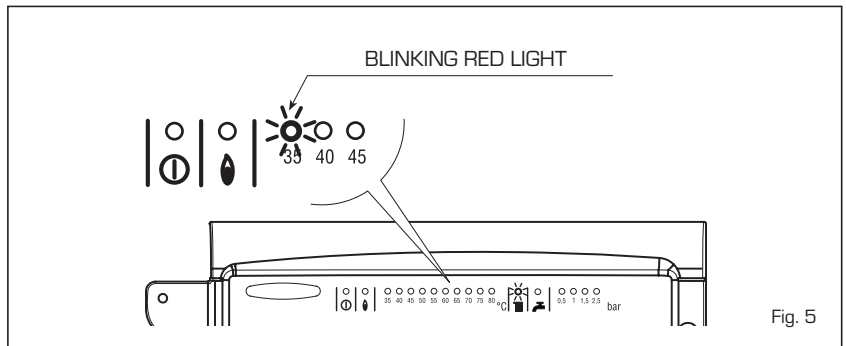

Fig. 5

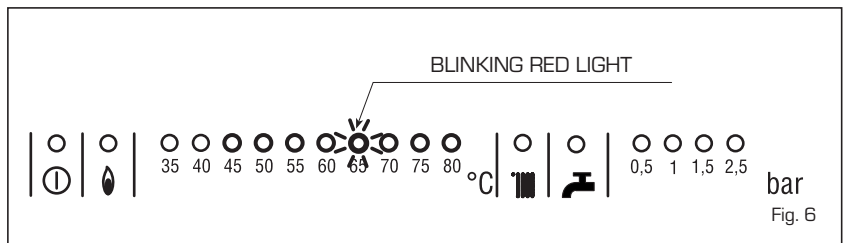

Fig. 6

“DEWY EQUIPE 60-120-180-240-300-360 BOX”

ALL “DEWY EQUIPE 60-120-180-240-300-360 BOX” HEAT MODULE FUNCTIONS CAN BE MANAGED FROM THE RVA 47.320 REGULATOR EQUIPPED WITH USE INSTRUCTIONS MANUAL.

WARNING: WHEN THESE MODULES ARE CONNECTED TO THE RVA 47.320 REGULATOR, THE “CR/OFF/INV/RELEASE SELECTOR MUST BE POSITIONED AS INDICATED IN FIG. 7.

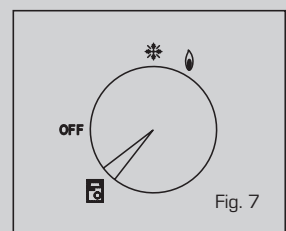

Fig. 7