

Shinhoo

LPA Series

Energy-saving Pipeline Canned Motor Pump



Installation and Operating Instructions



CE RoHS $EI \leq 0,23$

Hefei Xihu Canned Motor Pump Co., Ltd

Precautions for use of LPA Series products

01. The installation manual should be read carefully before installation and use.
02. Any failure to comply with the content marked by safety warning marks may cause personal injury, pump damage and other property loss, for which, the manufacturer shall not assume any responsibility and compensation.
03. Installer, operator and user must comply with the local safety regulations.
04. The user must confirm that installation and maintenance of the product should be conducted by staff proficient in the instructions and having professional qualification certificates.
05. Pumps must not be installed in damp environment or places that may be splashed by water.
06. In order to facilitate maintenance, one stop valve should be installed on each side of the pump inlet and outlet respectively.
07. The power supply of pump should be cut off during installation and maintenance.
08. Pump with copper or stainless steel body should be adopted to the domestic hot water circulation.
09. The heat feed pipeline should not be supplemented with non-softened water frequently to avoid an increase in the calcium in the circulating water of pipeline so as not to clog impellers.
10. It is prohibited to start the pump when there is no pumping liquid.
11. Some models can not be used for diet water.
12. Pumping liquid may be of high temperature and pressure, therefore, liquid in the system should be drained off or stop valves on both sides of the pump must be switched off to avoid burns before moving and removing pump.
13. Liquid of high temperature and pressure will flow out if exhaust bolts are removed; care must be taken to ensure that the liquid flowing out will not cause personal injury or damage to other parts.

14. In the summer or when the ambient temperature is high, attention should be paid to ventilation so as to prevent moisture condensation and cause electrical fault.
15. In the winter, if the pump system does not operate or when the ambient temperature is below 0 °C ,liquid in the pipeline system should be emptied to avoid causing frost crack to the pump body.
16. If the pump does not use for a long time, please turn off the conduit valves on pump inlet and outlet ends and cut off the power of pump.
17. If he flexible cord is damaged, please connect service center to have it replaced together with the connector.
18. If it is found that the motor is burning hot and abnormal, immediately turn off the valve on the pump inlet end and cut off the pump power, besides, immediately contact your local dealer or service center.
19. If the pump failure can not be cleared in accordance with the description in the instructions, immediately turn off the valve on the pump inlet end and cut off the pump power, besides, immediately contact your local dealer or service center.
20. The product should be placed out of the reach of children, after installation, isolation measures should be taken to prevent children from touching.
21. The product should be placed in a dry, ventilated and cool place and stored at room temperature.
22. This appliance can be used by children aged from 8 years and above and persons with reduced physical, sensory or mental capabilities or lack of experience and knowledge if they have been given supervision or instruction concerning use of the appliance in a safe way and understand the hazards involved. Children shall not play with the appliance.



Warning

Before starting installation, the Installation and Operating Instructions of device must be read carefully. Installation and use of the device must comply with local regulations and follow good operation specification.



Warning

Personnel with physical decline, dysesthesia or poor mental ability and lacking of experience and relevant knowledge (including children) should use the pump under the supervision and guidance of people who can take charge of their safety.

1. Symbol description



Caution

Warning: Failure to comply with this security declaration will likely result in personal injury!

Failure to comply with this security declaration will likely cause failure or damage to the equipment!

Note

Notes or instructions facilitating the work and ensuring operational safety.

2. Overview

2.1 LPA series circulating pump is mainly used for the water circulation in home heating and domestic hot water system.

LPA series circulating pump is most suitable for the following system:

- Stable heating system with variable flow
- Heating system with variable pipeline temperature
- Heating system with night mode
- Air-conditioning system
- Industrial circulation system
- Home heating and domestic water supply system

LPA series circulating pump is equipped with a permanent magnet motor and differential pressure controller which can adjust the performance of electric pump automatically and continuously to meet the actual needs of the system.

LPA series circulating pump is equipped with control panel on the front, which is convenient for the operation of users.

2.2 Advantages of installation of LPA series circulating pump. Easy installation and start-up

- LPA series circulating pump has autoadaptation mode AUTO (factory settings). In most cases, you can start the pump without need to make any adjustments and automatically adjust it to meet the actual needs of the system.

High comfort

- The running noise of pump and the whole system is low.

Low energy consumption

- Compared with the conventional circulating pump, its energy consumption is very low. The minimum energy consumption of LPA series circulating pump can reach 5W.

3. Service conditions

3.1 Ambient temperature

The ambient temperature is 0°C ~ +40°C.

3.2 Relative humidity of the air (RH)

The maximum humidity is 95%.

3.3 Media (conveying liquid) temperature

Temperature of liquid conveying +2°C ~ 110°C. To prevent the control box and stator from appearing condensate water, the temperature of pump conveying liquid must be always higher than the ambient temperature.

3.4 System pressure

The maximum is 1.0 Mpa (10 bar).

3.5 Protection Level

Ip42

3.6 Inlet pressure

To avoid damage to the pump bearing caused by cavitation noise, the following minimum pressure should be maintained in the pump inlet:

Liquid temperature	<85°C	90°C	110°C
Inlet pressure	0.05bar	0.28bar	1bar
	Head of delivery of 0.5m	Head of delivery of 2.8m	Head of delivery of 10m

3.7 Pumping liquid

Thin, clean, non-corrosive and non-explosive liquid does not contain any solid particles, fibers or mineral oil; the pump should not be used for conveying flammable liquid such as vegetable oil and gasoline absolutely. If the circulating pump is used for the case of high viscosity, the pump performance will reduce, therefore, when selecting a pump, the viscosity of liquid must be considered.

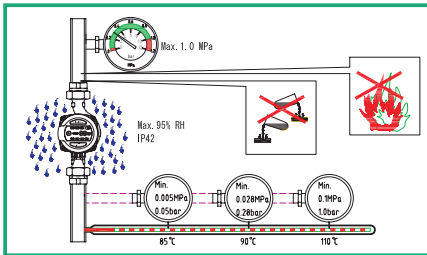

4. Installation

4.1 Installation

- Install LPA series circulating pump, arrows on the pump housing indicate the direction of liquid flowing through the pump body.
- When the pump is installed on the pipeline, its inlet and outlet must be installed with two leather packings provided.
- During installation, the pump shaft must be in the horizontal position.

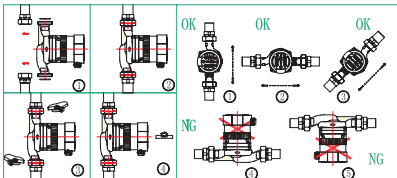

4.2 Position of junction box

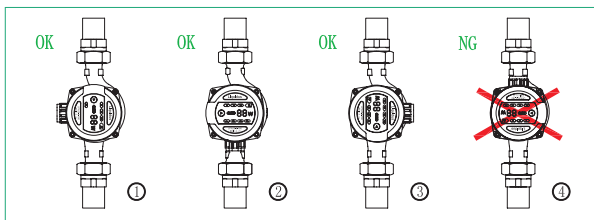

4.3 Change to the position of junction box

The junction box can rotate in 90° . To change the position of junction box, follow the operating steps below:

1. Switch the valves of inlet and outlet and conduct decompression;
2. Loosen and remove the four socket head cap screws that fix the pump body;
3. Rotate the motor to the desired position and match the four screw holes;
4. Put the four socket head cap screws back and tighten them in the cross direction order;
5. Open the valve of inlet and outlet.

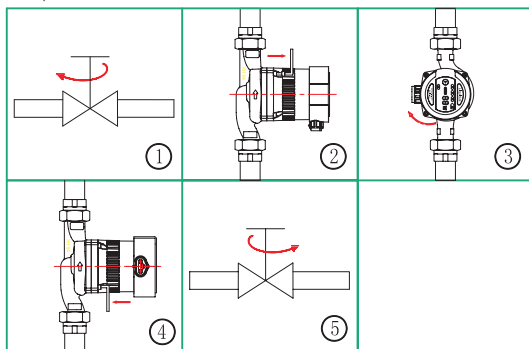

**Warning:**

Pumping liquid may be of high temperature and pressure, therefore, liquid in the system should be drained off or valves on both sides of the pump must be switched off before removing socket head cap screws.

Caution

Change the position of junction box, the pump should not be started until the system has been filled with pumping liquid or valves on both sides of the pump are open.

4.4 Thermal insulation of electric pump body

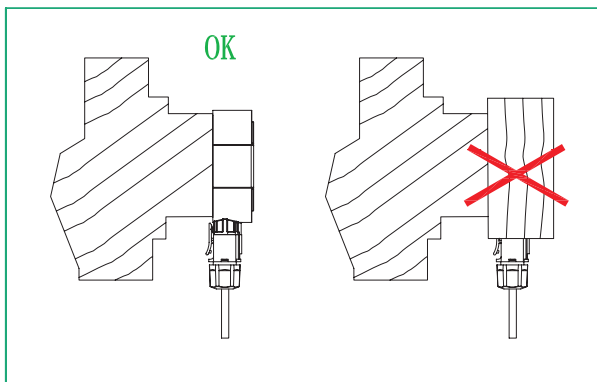
**Note**

Restrict the thermal losses of electric pump body and pipeline.

Conduct thermal insulation for electric pump body and pipeline so as to reduce the thermal losses of pump and pipeline.

Caution

Insulating or covering junction box and control panel is not allowed.

5. Electrical connection

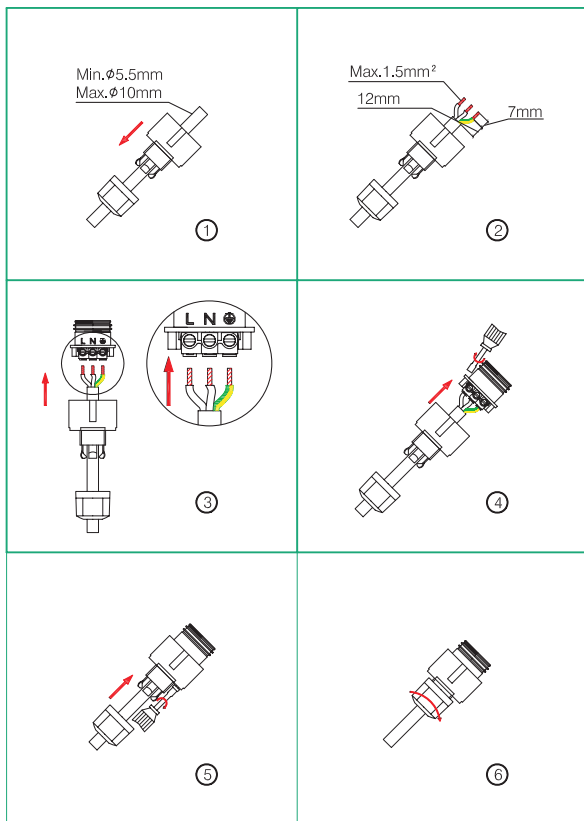

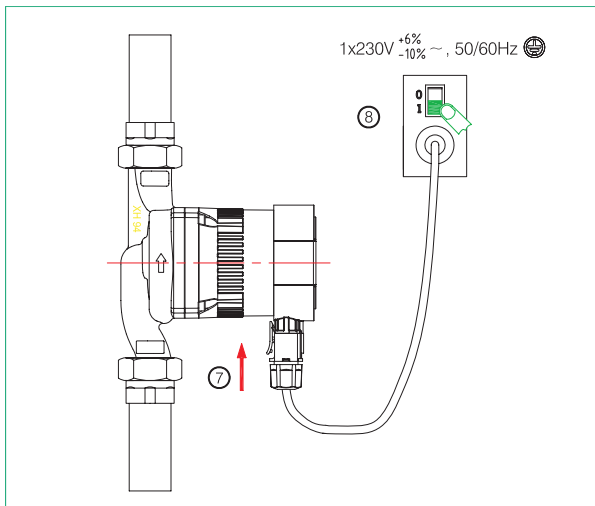

Electrical connection and protection should be carried out in accordance with local regulations.



Warning

The electric pump must be connected to earth wire. ⚡

The pump must be connected with an external power switch; the minimum gap between all the electrodes is 3 mm.

- LPA series circulating pump does not need external motor protection.
- Check whether the voltage of power supply and frequency match with the parameters marked by pump nameplate.
 - Use the pump associated plug to connect power supply.
 - If the indicator lamp on the control panel lights, it indicates that the power supply is switched on.

6. Control panel

6.1 Components on the control panel

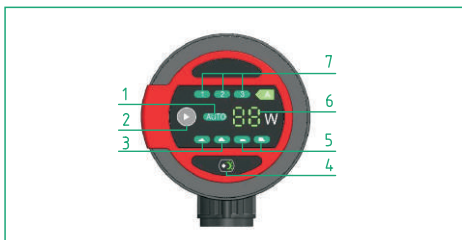

No.	Explanation
1	Electric pump automatic gearshift display (AUTO)
2	Electric pump gear shifting button
3	Electric pump proportion gear display (BL1/BL2)
4	Electric pump night mode button and display
5	Electric pump constant voltage gear display (HDI/HD2)
6	Electric pump power display
7	Electric pump constant speed display (HS1/HS2/HS3)

6.2 Fault code display status

After the power is turned on, position 6 light area displays the status. During operation, the gear display light is on constantly.

When the electric pump can not operate properly, the gear display light will flash continuously, the corresponding faults are as shown below:

Error Code	Description
E0	Over-voltage protection
E1	Under-voltage protection
E2	Over-current protection
E3	Under-load protection
E4	Missing phase protection
E5	Locked-rotor protection
E6	Motor start failure protection (Motor parameters do not match)

If the fault is displayed, the power supply must be disconnected to facilitate troubleshooting,

After troubleshooting, switch on the power supply again and re-start the electric pump.

6.3 Light area displaying the settings of electric pump

LPA series circulating pump has 9 kinds of settings, which can be selected by buttons.

The setting of electric pump is indicated by the light lit of 9 locations:

Key position	Number of times of key	Fixed light area	Explanation
2	0	AUTO	Auto adaptation
	1、2	BL1/BL2	Proportional pressure curve
	3、4	HD1/HD2	Constant pressure curve
	5、6、7	HS1/HS2/HS3	Constant speed curve
4	Switch on/off	Night mode	Night mode curve

7. Setting of electric pump

7.1 The electric pump should be set according to system type

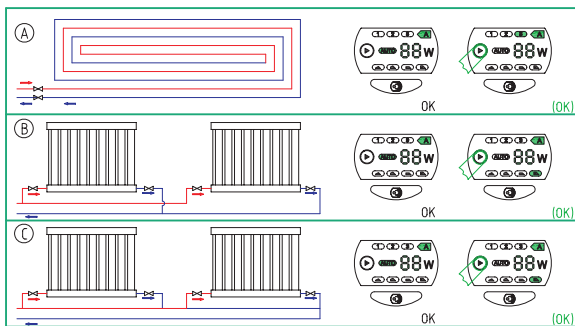

Factory settings= AUTO (autoadaptation mode)

Recommended and available settings of pump

Position	System type	Settings of electric pump	
		Optimal settings	Or other optional settings
A	Floor heating system	AUTO	HD1/HD2
B	Dual pipeline heating system	AUTO	BL1/BL2
C	Single pipeline heating system	BL1	BL1/BL2

- AUTO (autoadaptation) mode shall adjust the pump performance automatically according to the actual heat demand of system. Since performance is adjusted gradually, it is recommended that leave it in the AUTO (autoadaptation) mode for at least a week before changing the settings of pump.
- If you choose to change back to AUTO (autoadaptation) mode, LPA series pump can remember the set points of its previous AUTO mode and continue to adjust the performance automatically.
- Pump settings change from optimal settings to other optional settings
Heating system is a slow system, it is impossible to achieve optimal operation mode within several minutes or hours. If the optimal settings of pump fail to achieve ideal heat distribution for each room, you should change the pump settings to other settings.
- For the relationship between pump settings and performance curve, please see Section 10.1.

7.2 The control on electric pump

During the operation of pump, control it according to "proportional pressure control" (BL) principle or "constant pressure control" (HD) principle.

In these two control modes, the performance of pump and corresponding power consumption should

be adjusted according to the heat demand of system.

Constant pressure control

In this control mode, the pressure difference on both ends of the electric pump remains constant, having nothing to do with flow. In Q/H figure, constant pressure curve is a level performance curve, represented by HD1/HD2 (Section 11.3).

8.A bypass valve system is fitted between the inlet pipeline and return pipeline

8.1 Use of bypass valve

Bypass valve

The role of bypass valve is: when all the valves in the floor heating circuit or the temperature control valve of radiator are closed, it can be ensured that the heat from the boiler will be assigned.

System components:

- Bypass valve
- Flowmeter, position L.

The minimum flow must be ensured when all valves are closed.

Water pump settings depend on the type of bypass valve it equipped with, i.e. manually-operated bypass valve or temperature-controlled bypass valve.

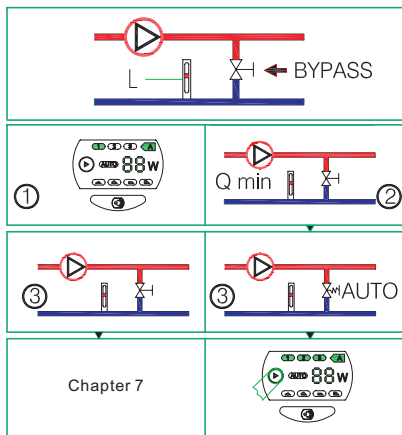

8.2 Manually-operated bypass valve

Follow the following steps:

1、 When adjusting the bypass valve, the water pump should be in setting HS1 (constant speed gear I mode).

The minimum flow of system (Q min) must always be ensured. See the manual of bypass valve manufacturer.

2、 When the bypass valve has been adjusted, set the water pump referring to Section 10.1 Pump Setting.

8.3 Automatic bypass valve (temperature control type)

Follow the following steps:

1、 When adjusting the bypass valve, the water pump should be in setting HS1 (constant speed gear I mode).

The minimum flow of system (Q min) must always be ensured. See the manual of bypass valve manufacturer.

2、 When the bypass valve has been adjusted, set the water pump to the constant pressure mode. For the relationship between pump settings and performance curve, please see Section 10.1. Settings and Performance of Water Pump.

.....

9. Startup

9.1 Before startup

Before starting the electric pump, make sure that the system is filled with liquid, gas has been vented, and the electric pump inlet pressure must achieve the minimum inlet pressure as required (see Chapter 3).

9.2 Gas-exhausting of electric pump

LPA series pump has automatic gas-exhausting function. There is no need for gas-exhausting before startup. Gas in the electric pump may cause noise.

The noise will disappear after putting it into operation for a few minutes. Set the LPA series electric pump to be HS3 mode in a short time according to the size and structure of system, then gas in the pump will be vented quickly. After gas-exhausting of pump, that is, after the noise disappears, set the electric pump according to the recommended instructions. Please refer to Chapter VII.



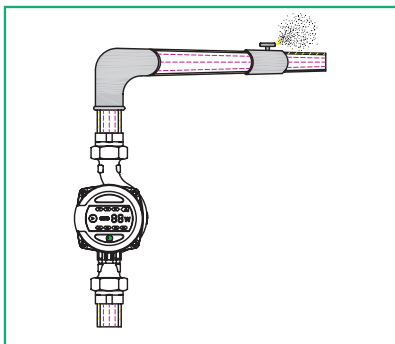

9.3 Gas-exhausting of heating system

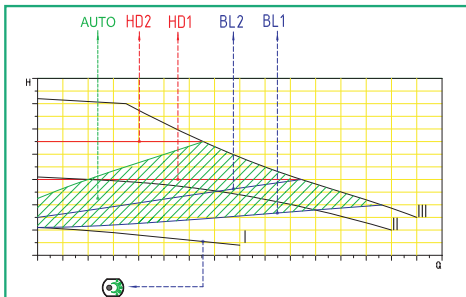

10. Settings and performance of pump

10.1 Relationship between pump settings and its performance



Settings	Water pump characteristic curve	Function
AUTO (factory settings)	Highest to lowest proportional pressure curve	<p>“Autoadaptation” function will automatically control the water pump performance within the specified range.</p> <ul style="list-style-type: none"> Adjust the performance of water pump according to the size of system; Adjust the performance of water pump according to the load change of a period of time; <p>In the “Autoadaptation” mode, the water pump is set to proportional pressure control mode.</p>
BL1/BL2	Proportional pressure curve	Water pump working point will move up and down on the proportional pressure curve according to the flow needs of system, when the flow demand reduces, the water pump pressure supply will drop while when the flow demand increases, it will rise.
HD1/HD2	Constant pressure curve	Water pump working point will move back and forth on the constant pressure curve according to the flow needs of system. The pressure supply of water pump remains constant, having nothing to do with the flow demand.
HS1/HS2 /HS3	Constant speed curve	Run on the constant curve at a constant speed. In speed HS (1–3) mode, the water pump is set to run on the maximum curve under all working conditions. Set the water pump to HS3 mode in a short time, then gas in the pump will be vented quickly.
	Night mode	Run at the lowest performance and power

11. Performance curve

11.1 Performance curve guide

Each setting of the pump will have a corresponding performance curve (Q/H curve). While AUTO autoadaptation mode covers a performance range. Input power curve (P1 curve) belongs to each Q/H curve. Power curve represents the power consumption (P1) of pump in watts on the given Q/H curve.

11.2 Curve conditions

The following description applies to the performance curves in LPA series manual:

- Testing liquid: gas-free water.
- Applicable density of curve $\rho = 983.2$ kg/cubic meter, and the liquid temperature is +60 °C.
- All the values expressed by curves are averages, they can not be taken as the guaranteed curves. If a particular performance is required, measurement must be conducted separately.
- Applicable kinematic viscosity of curve $\nu = 0.474$ mm²/s (0.474CcST)

11.3 Performance curve

- LPA XX-4 series

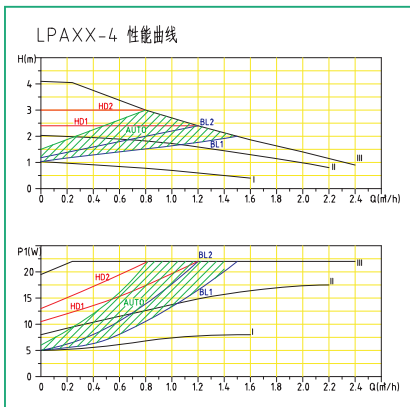

- LPA XX-5 series

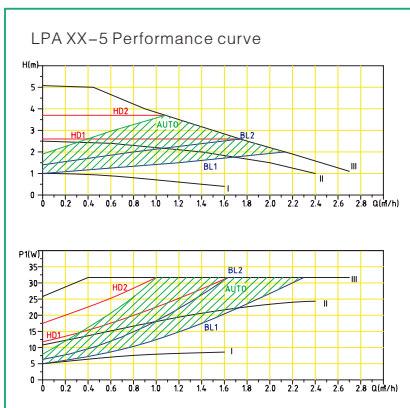

- LPA XX-6 series

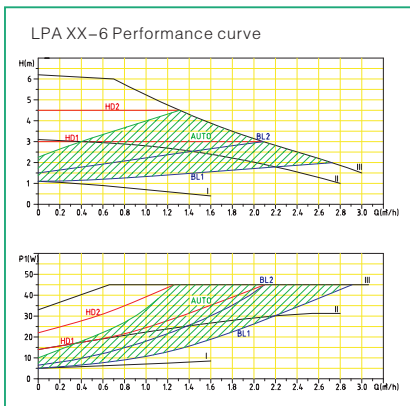

- LPA XX-8 series

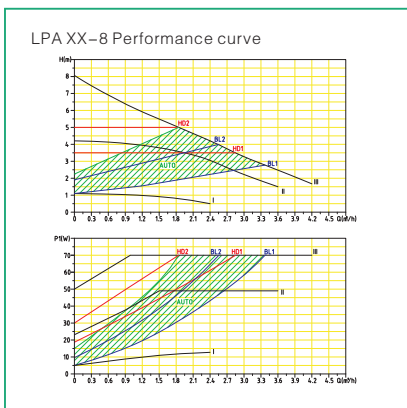

12. Characteristics

12.1 Description of nameplate

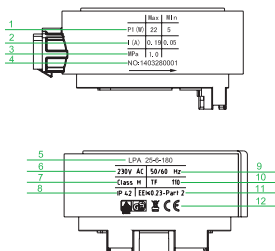

No.	Explanation	
1	Power	Maximum mode maximum power
		Minimum mode minimum power
2	Current	Maximum mode maximum current
		Minimum mode minimum current
3	Maximum pressure-bearing of system (MPa)	
4	Product No.	
5	Product Model	
6	Voltage (V)	
7	Insulation class	
8	Protection Level	
9	Frequency(Hz)	
10	Temperature grade	
11	Energy efficiency label	
12	Certification mark	
13	Manufacturer	

12.2 Model explanation

Pump model is consisted of upper Latin letters and Arabic numerals etc., whose meanings are as follows:

LPA □ - □ □

- C: indicating that the outlet of pump is fitted with check valve
- F: indicating that the pump body is connected by flanges, threaded connection is omitted
- Z: indicating that the inlet and outlet direction of pump is axial inflow, radial inflow is omitted
- P: indicating that the pump body is made of plastic material
- N: indicating that the pump body is made of stainless steel
- B: indicating that the pump body is made of copper, cast iron pump body is omitted
- Indicate the maximum head of delivery (m) of pump
- Indicate the inlet and outlet nominal diameter (DN) of pump
- Pipeline canned Class A energy-saving pump

Model example: LPA25-6, indicating that the inlet and outlet diameter of pump is DN25 with maximum head of delivery of 6m, the pump body is made of cast iron

13. Technical data and installation dimension

13.1 Technical data

Supply voltage	1 × 230V +6%/–10%, 50Hz, PE	
Motor protection	Pump does not need external protection	
Protection Level	IP42	
Insulation class	H	
Environmental relative humidity of the air (RH)	Max. 95%	
Pressure-bearing of system	1.0 Mpa (MPa)	
Suction inlet pressure	Liquid temperature	Minimum inlet pressure
	≤ +85°C	0.005 MPa
	≤ +90°C	0.028 MPa
	≤ +110°C	0.100 MPa
EMC standards	EN61000–6–1与EN61000–6–3	
Sound pressure level	The sound pressure level of water pump is below 43dB (A)	
Ambient temperature	0 ~ +40°C	
Temperature grade	TF110	
Surface temperature	°Caximum surface temperature should not exceed +125°C	
Liquid temperature	2 ~ +110°C	

To prevent the control box and stator from appearing condensate water, the temperature of pump conveying liquid must be always higher than the ambient temperature

Ambient temperature (°C)	Liquid temperature	
	Minimum (°C)	Maximum (°C)
0	2	110
10	10	110
20	20	110
30	30	110
35	35	90
40	40	70

In domestic hot water, it is recommended to keep the temperature of water below 65°C so as to reduce scaling

13.2 Installation dimension

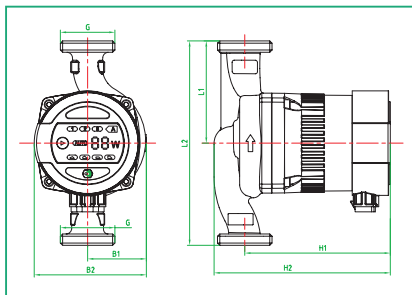

Power input (W)	Model	Voltage 220~ 240V/50Hz	Material				Dimension(mm)						
			Cast Iron	Plastic	Copper	Stainless steel	L1	L2	B1	B2	H1	H2	G
22	LPA20-4P	●	●			65	130	47	93	131	158	1"	
	LPA20-4	●	●	●	●	65	130	51	98	133	153		
						75	150	49	96	131	155		
	LPA25-4	●	●		●	●	65	130	52	99	128	156	1 1/2"
							75	150	49	96	131	155	
90							180	52	99	128	156		
LPA32-4	●	●			90	180	52	99	128	156	2"		
32	LPA20-5P	●		●		65	130	47	93	131	158	1"	
	LPA20-5	●	●	●	●	65	130	52	99	133	153		
						75	150	49	96	131	155		
	LPA25-5	●	●		●	●	65	130	52	99	128	156	1 1/2"
							75	150	49	96	131	155	
90							180	52	99	128	156		
LPA32-5	●	●			90	180	52	99	128	156	2"		
45	LPA20-6P	●		●		65	130	47	93	131	158	1"	
	LPA20-6	●	●		●	●	65	130	52	99	133		153
							75	150	49	96	131		155
	LPA25-6	●	●		●	●	65	130	52	99	128	156	1 1/2"
							75	150	49	96	131	155	
90							180	52	99	128	156		
LPA32-6	●	●			90	180	52	99	128	156	2"		

Power input (W)	Model	Voltage 220~ 240V/50Hz	Material				Dimension(mm)						
			Cast Iron	Plastic	Copper	Stainless steel	L1	L2	B1	B2	H1	H2	G
70	LPA20-8	●	●		●	●	65	130	52	98	133	153	1"
	LPA25-8		●		●	●	65	130	52	99	128	156	1 1/2"
						●	●	75	150	49	96	131	
				●		●	●	90	180	52	99	128	156
LPA32-8		●		●	●	90	180	52	99	128	156	2"	

14. Trouble-Shooting Schedule



Warning

Before conducting any maintenance and repair of the motor pump, ensure that power supply has been cut off and will not be connected accidentally.

Symptom	Control Panel	Cause	Corrective Action
Motor pump cannot be started	Indication lamp "Off"	Equipment fuse burned	Replace the fuse
		The circuit breaker of current control or voltage control opens	Connect the circuit breaker
		Failure of motor pump	Return to factory maintenance
	E0	High voltage	Check whether power supply is in specified range
	E1	Under voltage	Check whether power supply is in specified range
	E2	PCB component failure or motor failure	Return to factory maintenance
	E3	No water in the pump	Open the valve and supply water to the pump
	E4	Missing phase protection	Return to factory maintenance
	E5	Rotor blocked	Remove the pump housing and clean the rotor
E6	Motor resistance parameters do not match	Return to factory maintenance	
Noise in the system	Indicating one value	Air exists in the system	Vent the system
		Excessively high flow rate	Lower inlet pressure of the motor pump
Noise in the motor pump	Indicating one value	Air exists in the motor pump	Vent the system
		Excessively low inlet pressure	Increase inlet pressure
Insufficient heat	Indicating one value	Poor performance of motor pump	Increase inlet pressure of motor pump

Product warranty book of Hefei Xihu

Hefei Xihu Canned Motor pump Co., Ltd provides 12 months' quality assurance for the products since the sales date, and shall be responsible for the product failure or damage caused by manufacturing and material defects. The warranty is on condition that the installation of product should be in line with Xihu Installation and Use Manual and recognized good operation specification.

This warranty does not apply to the product ailure or damage caused by ① use the product other than for the usage recommended by Xihu; ② misuse of the product that does not conform to Xihu Installation and Use Manual; ③ improper maintenance and handling of product; ④ disassemble products and replace parts by oneself.

Any product provided rather than manufactured by Hefei Xihu Canned Motor pump Co., Ltd should comply with the quality assurance provisions of the manufacturer.

Within warranty period, the product repair is guaranteed by purchase invoice and warranty bill. Please send or return the product in need of repair to the local dealer of Hefei Xihu Canned Motor pump Co., Ltd. or designated maintenance point for repair. Hefei Xihu Canned Motor pump Co. may determine whether home maintenance service shall be provided for free in accordance with its maintenance policies in the local. Guarantee repair of parts is free.

Hefei Xihu Canned Motor pump Co., Ltd. will not accept claims to damage which should be borne by a third party or caused by product failure of any other company.

Hefei Xihu Canned Motor pump Co., Ltd shall not be responsible for the product failure or damage due to abnormal operating conditions, war, riot, wind (rain) storm, disaster or other force majeure.

Hefei Xihu Canned Motor pump Co., Ltd reserves the power of interpretation on the unaccomplished matter in the product warranty book.

HEFEI XINHU CANNED MOTOR PUMP CO., LTD

Hi-Tech Industrial Development Zone, Hefei, P.R. China.