

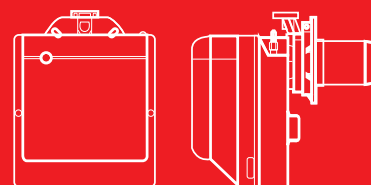

Gulliver BS Series

Low NO_x One Stage Gas Burners

BS1	16 ÷ 52	kW
BS2	35 ÷ 91	kW
BS3	65 ÷ 189	kW
BS4	110 ÷ 246	kW



The Riello Gulliver BS series of one stage gas burners, is a complete range of Low NOx emission products, developed to respond to any request for home heating, conforming to the most severe standards regarding the reduction of polluting emissions. This series of burners is available in four different models with an output ranging from 16 to 250 kW, divided in four different structures.

All the models use the same components designed by Riello for the Gulliver series. The high quality level guarantees safe working. The burners are fitted with a microprocessor-based burner safety control box which supplies indication of operation and diagnosis of fault cause.

In developing these burners, special attention was paid to reducing noise, the ease of installation and adjustment, to obtaining the smallest size possible to fit into any sort of boiler available on the market.

All the models are approved by the EN 676 European Standard and conform to European Directives, Gas Appliance, EMC, Low Voltage, Boiler Efficiency.

All the Gulliver BS burners are tested before leaving the factory.

Technical Data

MODEL			BS1	BS2	BS3	BS4
Burner operation mode			One stage			
Modulation ratio at max. output			--			
Servomotor		type	--			
		run time s	--			
Heat output		kW	16 ÷ 52	35 ÷ 91	65/75 ÷ 190	110 ÷ 250
		Mcal/h	13.8 ÷ 44.7	30.1 ÷ 78.3	55.9 ÷ 172	94.6 ÷ 215
Working temperature		°C min./max.	0/40			
FUEL/AIR DATA						
G20 gas	net calorific value	kWh/Nm ³	10			
	gas density	kg/Nm ³	0.71			
	gas delivery	Nm ³ /h	1.6 ÷ 5.2	3.5 ÷ 9.1	6.5 ÷ 18.9	11 ÷ 24.6
G25 gas	net calorific value	kWh/Nm ³	8.6			
	gas density	kg/Nm ³	0.78			
	gas delivery	Nm ³ /h	1.9 ÷ 6	4 ÷ 10.6	7.6 ÷ 22	12.8 ÷ 28.6
LPG gas	net calorific value	kWh/Nm ³	25.8			
	gas density	kg/Nm ³	2.02			
	gas delivery	Nm ³ /h	0.6 ÷ 2	1.3 ÷ 3.5	2.5 ÷ 7.3	4.3 ÷ 9.5
Fan		type	Centrifugal with forward curve blades			
Air temperature		max °C	40			
ELECTRICAL DATA						
Electrical supply		Ph/Hz/V	1/50/230 (±10%)			
Auxiliary electrical supply		Ph/Hz/V	--			
Control box		type	MG569			
Total electrical power		kW	0.15	0.18	0.35	0.53
Auxiliary electrical power		kW	--			
Protection level		IP	X0D			
Fan motor	electrical power	kW	0.09		0.15	0.25
	rated current	A	0.8	0.8	1.7	1.9
	start up current	A	3.2	3.2	6.8	7.6
	protection level	IP	20			
Ignition transformer		type	Incorporated in the control box			
		V1 - V2	230V - 8 kV			
		I1 - I2	0.2 A - 12 mA			
Operation			Intermittent (at least one stop every 24 h)			
EMISSIONS						
Noise levels	sound pressure	dB(A)	61	62	66	71
	sound power		72	73	77	82
Gas G20	CO emission	mg/kWh	< 40			
	NOx emission	mg/kWh	< 80			
APPROVAL						
Directive			2006/42 EC - 2009/142 EC- 2014/30 UE - 2014/35 UE			
Conforming to			EN 676 - EN 12100			
Certification			CE-0085A00409			

Reference conditions:

Temperature: 20°C - Pressure: 1013.5 mbar - Altitude: 0 m a.s.l. - Sound pressure measured in manufacturer's combustion laboratory, with burner operating on test boiler and at maximum rated output. The sound power is measured with the "Free Field" method, as per EN 15036, and according to an "Accuracy: Category 3" measuring accuracy, as set out in EN ISO 3746.

Firing Rates

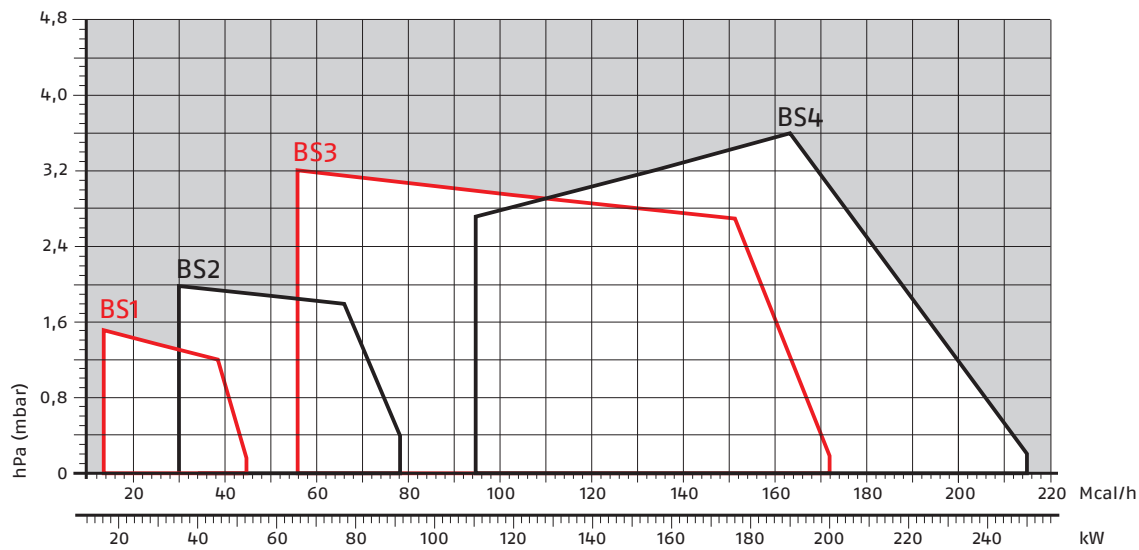

 Useful working field for choosing the burner
 Test conditions conforming to EN676
 Temperature: 20°C
 Pressure: 1013,5 mbar
 Altitude: 0 m a.s.l.

Gas train

GAS TRAIN DESIGNATION

Series: MB	
MBC	
Size:	403 405 407 410 412
	65
Operation: /1 stage mode opening	
Leak detection control: - 0	
Joint type: R threaded joint	
	F1 square flange BS1
	F2 square flange BS2
	F3 square flange BS3 - BS4
Electrical connection: SD Domestic plug	
Standard output pressure range:	
	- without pressure governor
	0 with governor and air/gas proportional pressure
	2 with governor and output pressure up to 20 mbar
	3 with governor and output pressure up to 30 mbar
	4 with governor and output pressure up to 40 mbar
	5 with governor and output pressure up to 50 mbar
Valve control: 0 shared	

MB	407	/1		F2	SD	2	0
----	-----	----	--	----	----	---	---

BASIC DESIGNATION

EXTENDED DESIGNATION

GAS TRAINS

The burners are set for fuel supply from either the right or left hand sides.

Depending on the fuel output and the available pressure in the supply line, you should check the correct gas train to be adapted to the system requirements.

The gas train is Multibloc type, containing the main components in a single unit.

Except for the MBC 65/1 model, a valve seal control (as accessory) can be fitted to the Multibloc gas trains.

The MBC 65/1 gas train can be fitted only to the left of the burner.

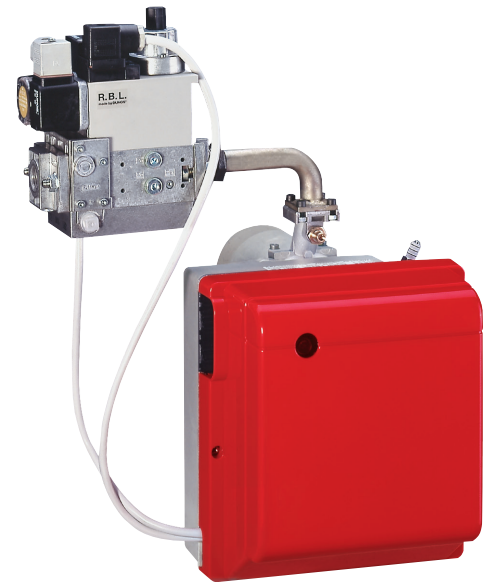

Gas train installed on the burner

MB 403/1 - 405/1 - 407/1 - 410/1 - 412/1

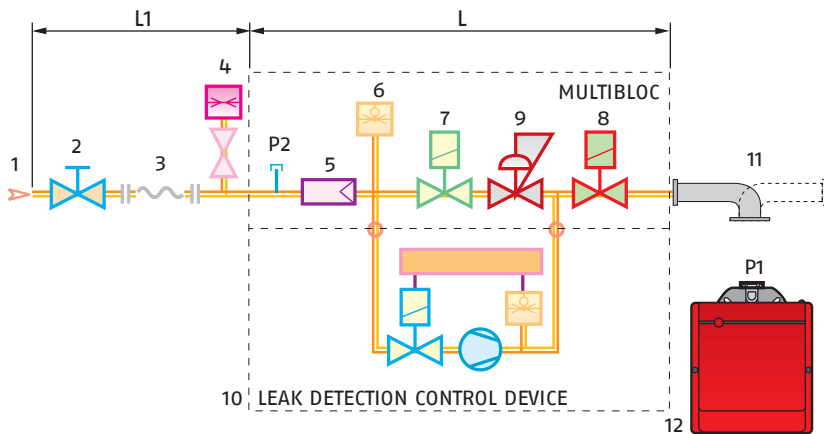

MBC 65/1

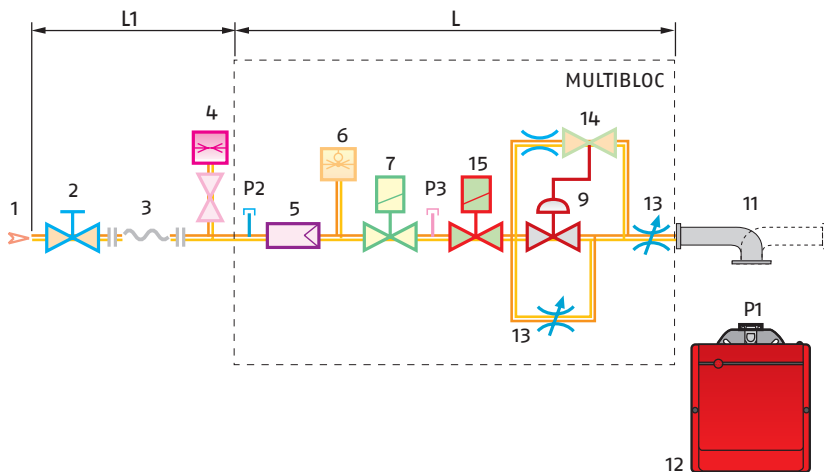

1	Gas input pipework
2	Manual valve
3	Anti-vibration joint
4	Gas pressure gauge
5	Filter
6	Gas pressure switch
7	Safety valve
8	Adjustment solenoid: firing delivery adjustment (rapid opening) maximum delivery adjustment (slow opening)
9	Pressure adjuster
10	Leak detection device for valves 7 and 8 (accessory)
11	Gas train-burner adapter
12	Burner
13	Shutter with adjustment screws
14	Pressure regulator setting device
15	Regulation solenoid
P1	Combustion head pressure
P2	Upstream pressure from the filter
P3	Upstream pressure from the control valve
L	Gas train supplied separately
L1	Installer's responsibility

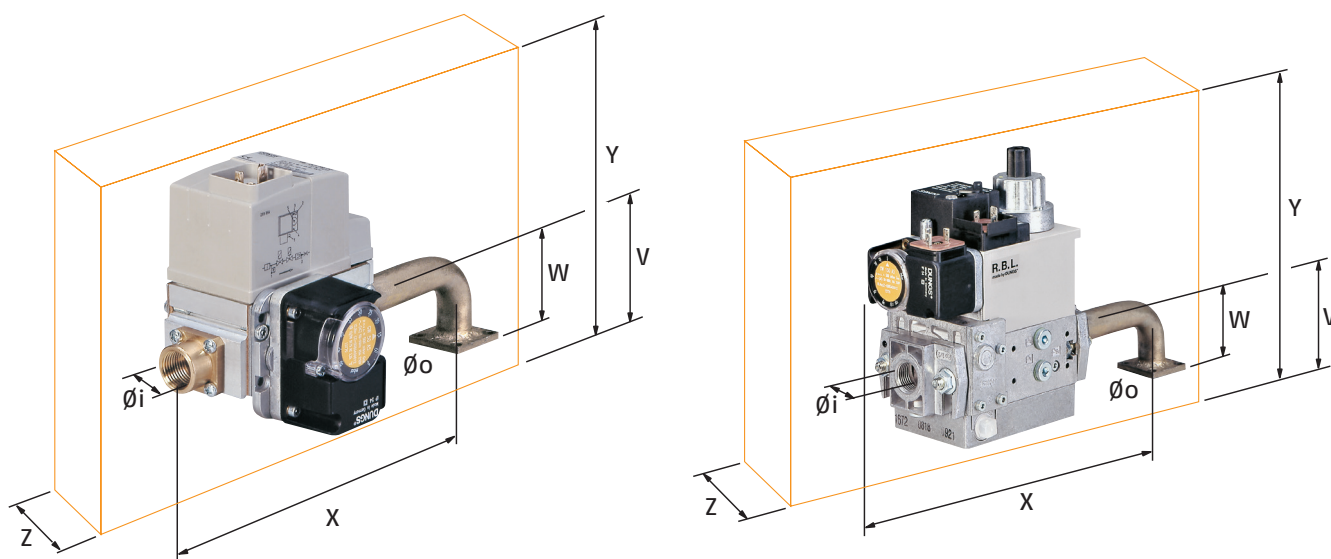

The dimensions of the gas trains vary depending on their construction features.

The following table shows the dimensions of the gas trains that can be fitted to Gulliver BS burners, intake diameter and the coupling flange to the burner.

GAS TRAIN									
MODEL	CODE	Ø in	Ø out	X mm	Y mm	W mm	Z mm	V mm	mbar max*
MBC 65/1	3970570	1/2"	FLANGE 1	232	126	45	122	31	65
MB 403/1	3970545	1/2"	FLANGE 1	200	137	45	100	26	200
MB 405/1	3970546	1/2"	FLANGE 1	246	186	45	120	46	300
MB 405/1	3970547	3/4"	FLANGE 2	236	186	47	120	46	300
MB 407/1	3970544	3/4"	FLANGE 2	236	186	47	120	46	300
MB 407/1	3970548	3/4"	FLANGE 3	236	186	47	120	46	300
MB 410/1	3970549	1" 1/4	FLANGE 3	259	215	47	145	55	300
MB 412/1	3970550	1" 1/4	FLANGE 3	259	215	47	145	55	300

* max inlet gas pressure (mbar)

Pressure Drop Diagram

The diagrams indicate the minimum pressure drop of the burners with the various gas trains that can be matched with them; at the value of these pressure drop add the combustion chamber pressure. The value thus calculated represents the minimum required input pressure to the gas train.

BS1 (NATURAL GAS)

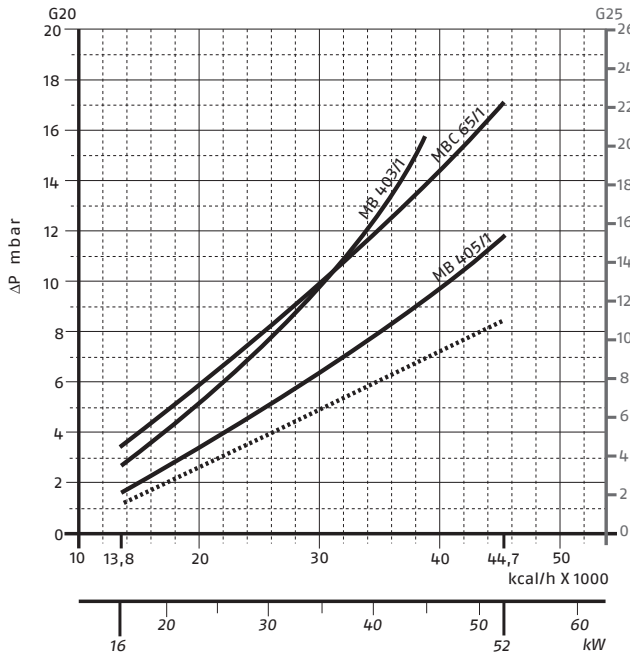

BS1 (LPG)

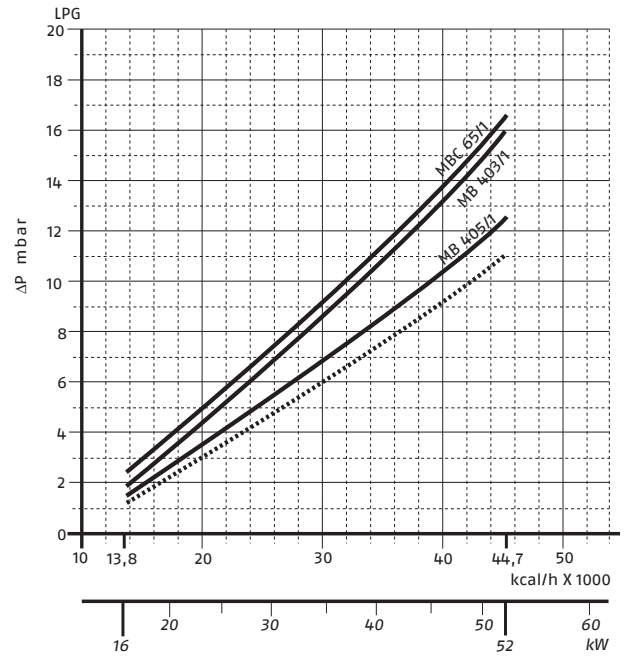

BS2 (NATURAL GAS)

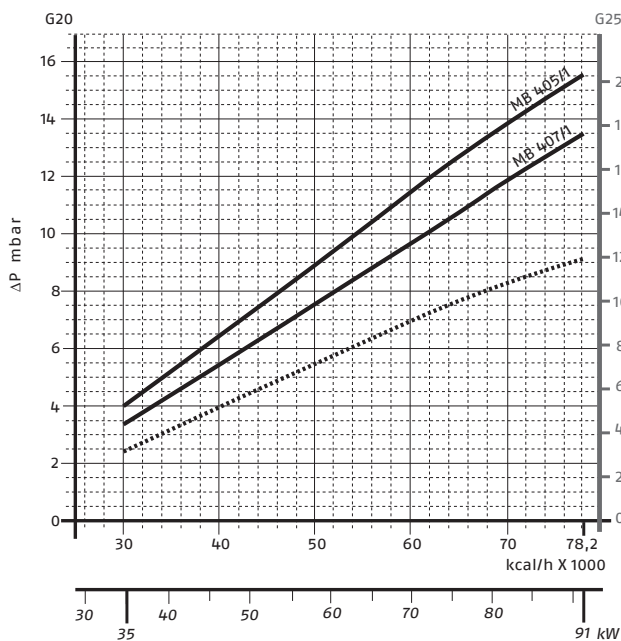

BS2 (LPG)

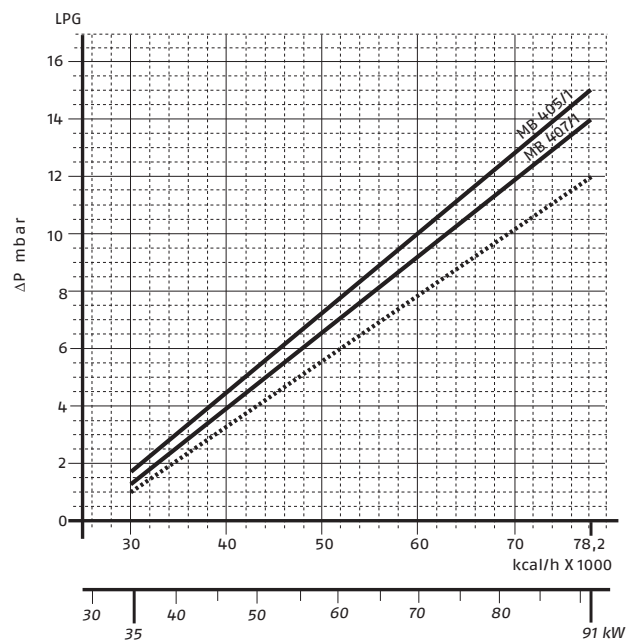

— Combustion head + gas train
 - - - Combustion head

BS3 (NATURAL GAS)

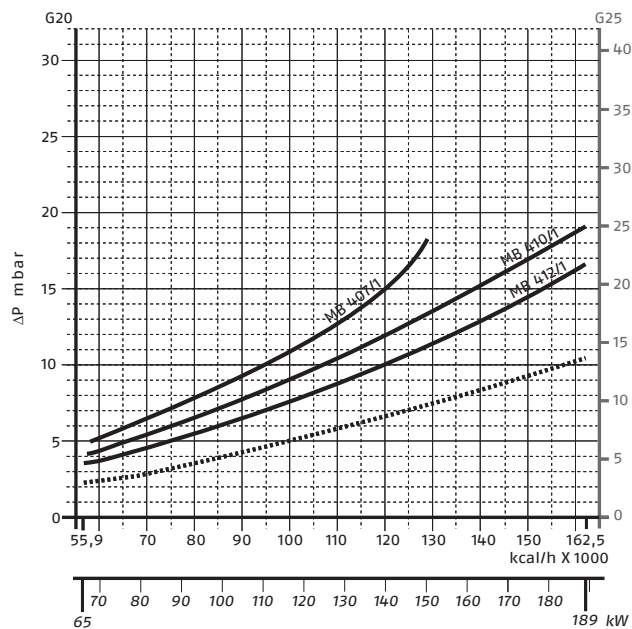

BS3 (LPG)

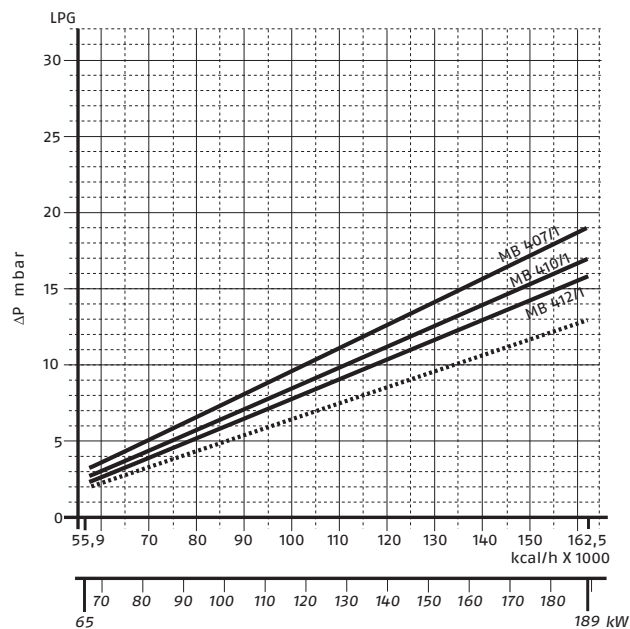

BS4 (NATURAL GAS)

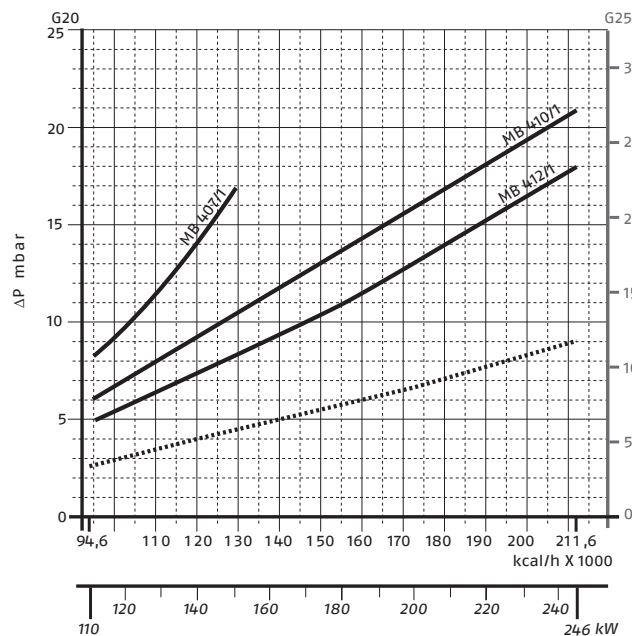

BS4 (LPG)

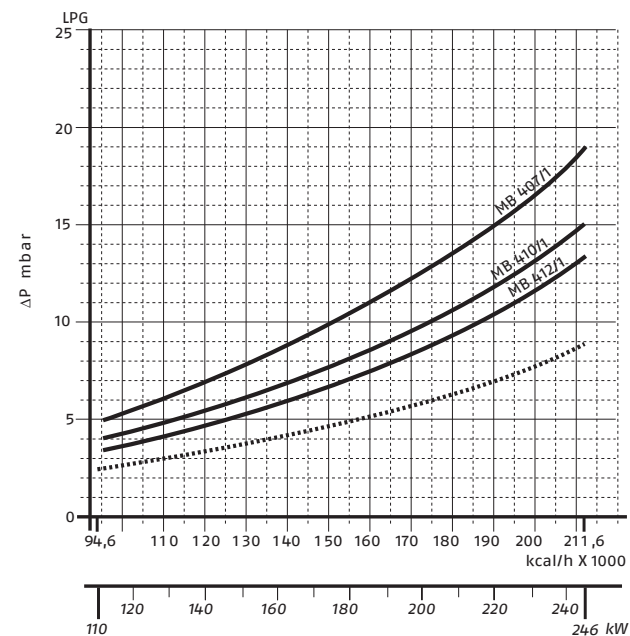

For pressure levels different from those indicated above, please contact Riello Burners Technical Office.

In LPG plants, Multibloc gas trains do not operate below 0°C.

They are only suitable for gaseous LPG (liquid hydrocarbons destroy the seal materials).

- Combustion head + gas train
- - - Combustion head

GAS TRAIN				
CODE	MODEL	BURNER MODEL	OUTPUT	PLUG AND SOCKET
3970545	MB 403/1 - F2SD 20	BS1	≤ 45 kW *	●
3970546	MB 405/1 - F1SD 20	BS1	-	●
3970570	MBC 65/1 - F1SD 20	BS1	-	●
3970547	MB 405/1 - F2SD 20	BS2	-	●
3970544	MB 407/1 - F2SD 20	BS2	-	●
3970548	MB 407/1 - F3SD 20	BS3 - BS4	≤ 150 kW *	●
3970549	MB 410/1 - F3SD 20	BS3 - BS4	-	●
3970550	MB 412/1 - F3SD 20	BS3 - BS4	-	●

Key to layout

* with natural gas

Ventilation

The different ventilation circuits always ensure low noise levels with high performance of pressure and air delivery, inspite of their compact size.

The burners are fitted with an adjustable air pressure switch, conforming to EN 676 standards.



Air suction

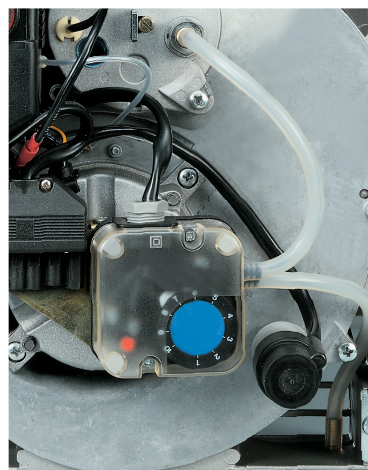

Air pressure switch

Combustion Head

The combustion head in Gulliver BS burners is the result of an innovative design, which allows combustion with low polluting emissions, while being easy to adapt to all the various types of boilers and combustion chambers.

Thanks to the use of a mobile coupling flange, the penetration of the head into the combustion chamber can be adjusted.

Simple adjustment allows the internal geometry of the combustion head to be adapted to the burner output.

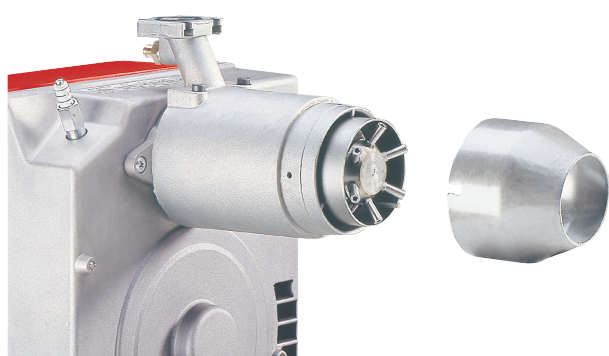

Combustion head

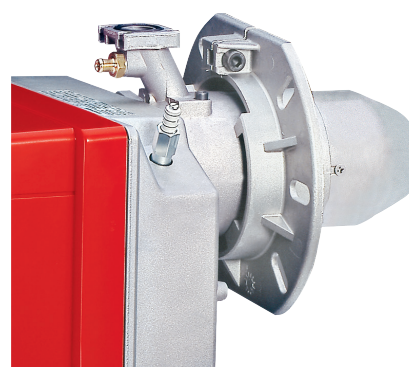

Mobile flange

DIMENSIONS OF THE FLAME

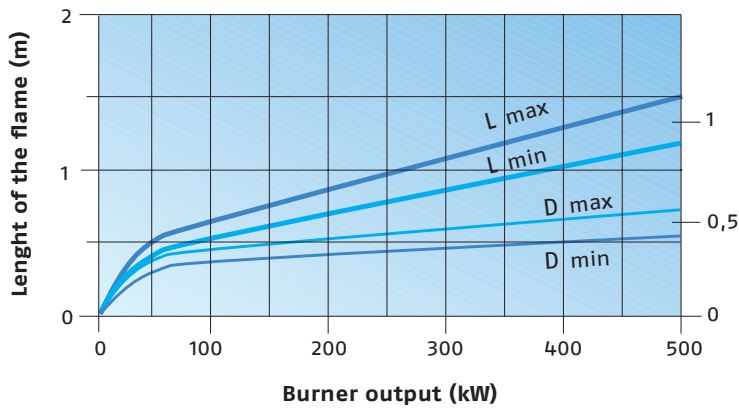

Diameter of the flame (m)

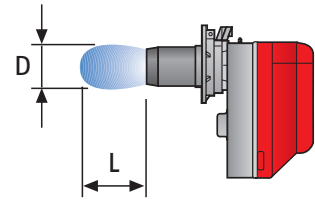

Example:
 Burner thermal output = 350 kW;
 L flame (m) = 1.2 m (medium value);
 D flame (m) = 0.6 m (medium value)

Operation

BURNER OPERATION MODE

All these models are one stage operation.

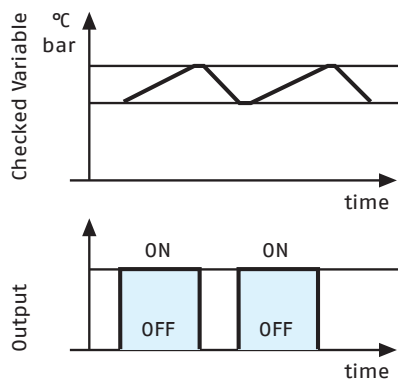

One stage operation



Air damper adjustment

All Gulliver BS series burners are fitted with a new microprocessor control panel for the supervision during intermittent operation. For helping the commissioning and maintenance work, there are two main elements:



The lock-out reset button is the central operating element for resetting the burner control and for activating / deactivating the diagnostic functions.



The multi-color LED is the central indication element for visual diagnosis and interface diagnosis.

Both elements are located under the transparent cover of lock-out reset button, as showed below.

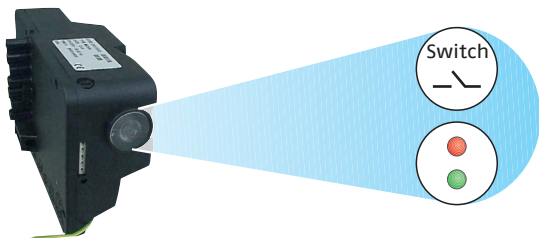

There are two diagnostic choices, for indication of operation and diagnosis of fault cause:

- visual diagnosis:

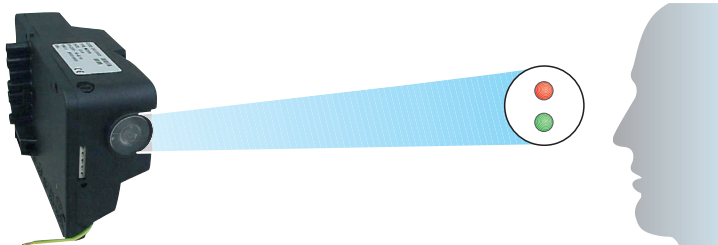

- interface diagnosis:

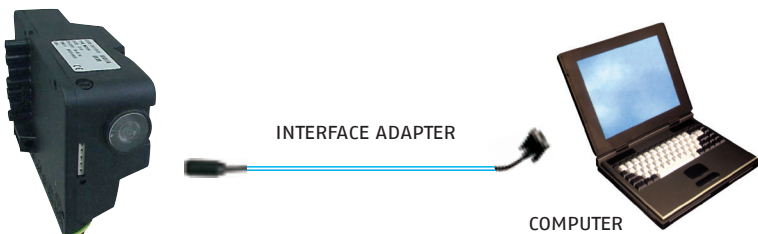

By the interface adapter and a PC with dedicated software.

Indication of operation

In normal operation, the various status are indicated in the form of colour codes according to the table.

Diagnosis of fault causes

After lock-out has occurred, the red signal lamp is steady on.

In this status, the visual fault diagnosis according to the error code table can be activated by pressing the lock-out reset button for over 3 seconds.

The control box sends a sequence of pulses that are repeated at 2 second intervals.

The interface diagnosis (with adapter) can be activated by pressing again the lock-out button for over 3 seconds.

Color code table

Operation status	Color code
Stand-by	○ Led off
Pre-purging	● Green
Ignition phase	● Green
Flame OK	● Green
Post purge	● Green
Undervoltage, built-in fuse	○ Led off
Fault, alarm	● Red

Example of blinks sequence:

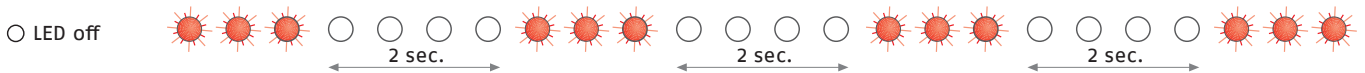

Error code table

Blink code	Possible cause of fault
2 blinks 	No flame at the end of safety time: - faulty or soiled gas valves - faulty ionisation probe - poor adjustment of burner, no gas - faulty ignition - neutral / phase exchange
3 blinks 	Air pressure switch does not close or is already closed before heat demand: - faulty air pressure switch - air pressure switch incorrectly regulated
4 blinks 	Presence of flame: - in stand-by position - with thermostat of heat demand in idle or working position - during pre-purge - during post-purge
6 blinks 	Loss of air pressure: - during pre-purge - during or after safety time
7 blinks 	Loss of flame during operations after n°3 attempts of re-cycle: - faulty or soiled gas valves - faulty ionisation probe - short circuit between ionisation probe and earth of the burner - poor adjustment of burner, no fuel

The MG569 digital control box gives some other advantages:

Post ignition (during safety time)

The spark ignition is present during all safety time.

Adjustable post purge

The Post-purge is a function that maintains air ventilation even after the burner is switched off.

Post-purge time can be set to a maximum of 6 minutes.

This function can be activated and set in a very easy way by pressing repeatedly the reset button; after 5 seconds the control box automatically shows the minutes set by the red LED flashing (1 pulse = post-ventilation for 1 minute).

If during post-purge there is a new request for heat, it is halted and a new operating cycle starts.

The control box leaves the factory with the setting 0 minutes (no post-ventilation).

Remote lock-out reset

The "Remote lock-out reset" is a function that allows to reset the control-box operation from a remote position.

In the burner packages will be included a particular connector to remote the reset signal.

The maximum length of connection must be 20 m.

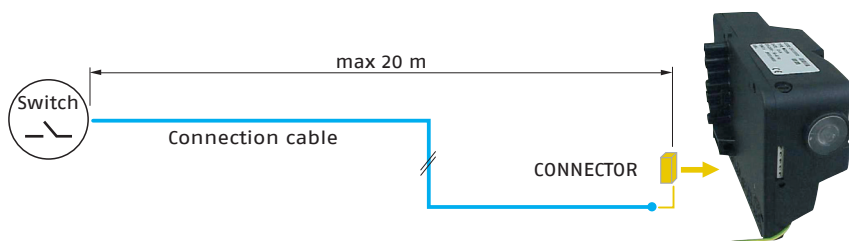

START UP CYCLE

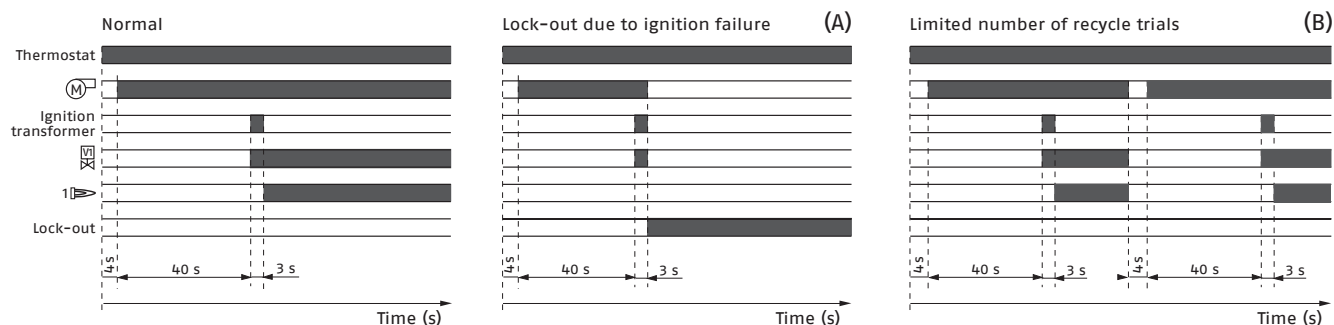

(A) Lock-out is shown by a led on the appliance.

(B) Total number of recycle trials is 3

Correct operation

- 0s Start of heat demand the burner begins the ignition cycle
- 0s-4s The burner is in stand-by
- 4s-44s Pre-purge with opened air damper
- 44s Ignition

Lock-out due to ignition failure

If the flame does not light within the safety limit (~ 3s) the burner locks-out.

Re-cycle

The burner permits maximum three repetitions of complete ignition cycle if there is flame failure during operation. The burner goes in safety shut-down within one second.

The final action at the last trial following at last flame failure is a lock-out.

Emissions

The burners in the Gulliver BS series guarantee controlled combustion, reducing emissions of both CO and NOx, this combustion control is due to the recirculation of the combustion products in the chamber (thanks to different combustible air flow speeds) and to the fuel staging technique (thanks to the special geometry of the gas nozzles).

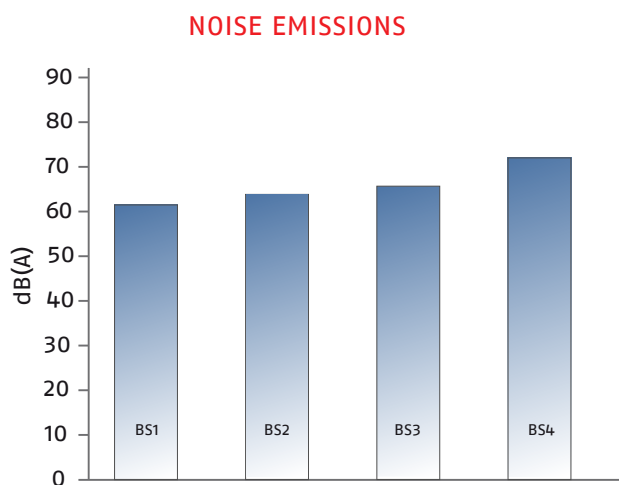
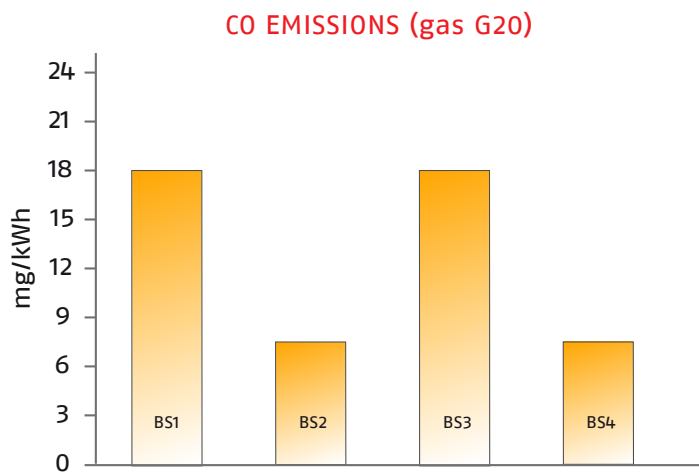
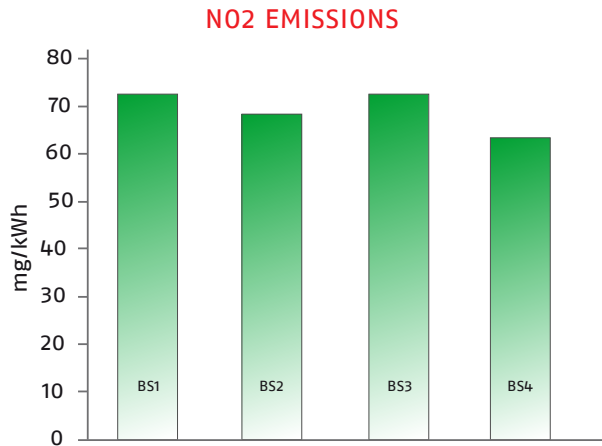

The emission data have been measured in the various models at maximum output, in conformity with EN 676 standard.

Special attention has been paid to noise reduction. All models are fitted with sound-proofing material inside the cover.



Overall Dimensions (mm)

These models are distinguished by their reduced size, in relation to the outputs achieved, which means they can be fitted to any boiler on the market.

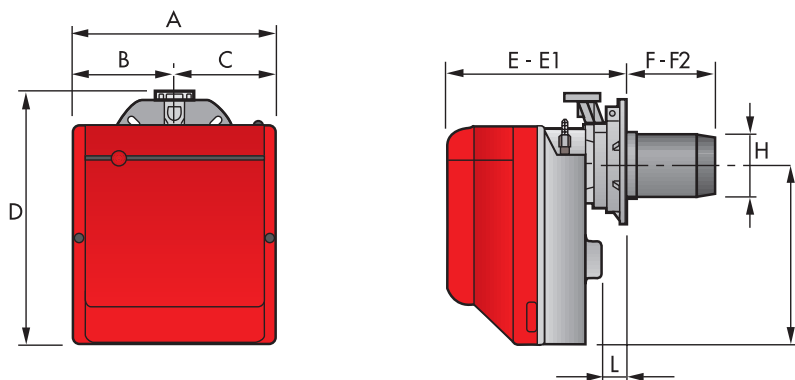

MODEL	A	B	C	D	E	E1	F	F2	H	I	L
BS1	234	122	122	295	230	276	116	70	89	210	41
BS2	255	125.5	125.5	325	238	252	114	100	106	230	45
BS2 TL	255	125.5	125.5	325	238	252	184	170	106	230	45
BS3	300	150	150	391	262	280	128	110	129	285	45
BS3 TL	300	150	150	391	262	280	285	267	129	285	45
BS4	300	150	150	392	271	301	168	145	137	286	45
BS4 TL	300	150	150	392	271	301	325	302	137	286	45

BURNER - BOILER MOUNTING FLANGE

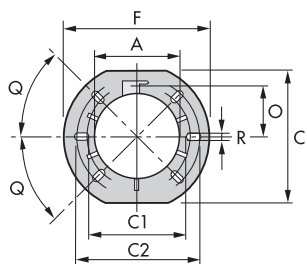

MODEL	A	C	C1	C2	F	O	Q	R
BS1	89	167	140	170	192	66	45°	11
BS2 - BS2 TL	106	167	140	170	192	66	45°	11
BS3 - BS3 TL	129	201	160	190	216	76.5	45°	11
BS4 - BS4 TL	137	203	170	200	218	80.5	45°	11

PACKAGING

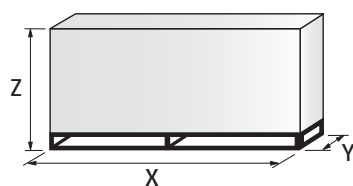

MODEL	X	Y	Z	kg
BS1	395	278	350	10
BS2	405	298	375	11
BS2 TL	583	290	370	11 - 13
BS3	450	345	440	15
BS3 TL	703	335	435	15 - 17
BS4	510	345	440	16.5
BS4 TL	703	335	435	16.5 - 18.5

Installation Description

Installation, start up and maintenance must be carried out by qualified and skilled personnel. The burner is set in the factory on standard calibration (minimum output). If necessary adjustments can be made on the basis of the maximum output of the boiler. All operations must be performed as described in the technical handbook supplied with the burner.

The mobile flange allows adapting the length of the combustion head to the combustion chamber (flame inversion or 3 smoke cycles) and to the thickness of the boiler panel.

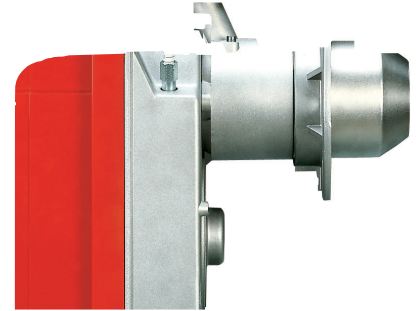

BURNER SETTING

The air damper position can be adjusted without removing the burner cover.



Head setting is easy and aided by a graduated scale; a test point allows reading the air pressure in the combustion head.

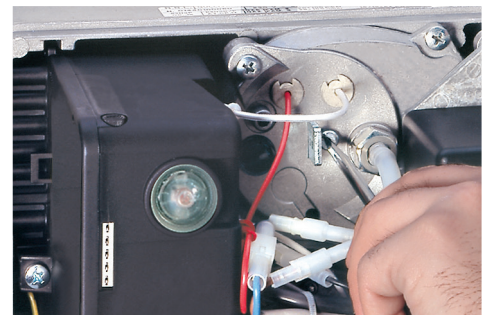

Gulliver BS burners are fitted with an air pressure switch which, in accordance with EN 676 standards, can be adjusted by the installer using a graduated selector, on the basis of the effective working conditions.

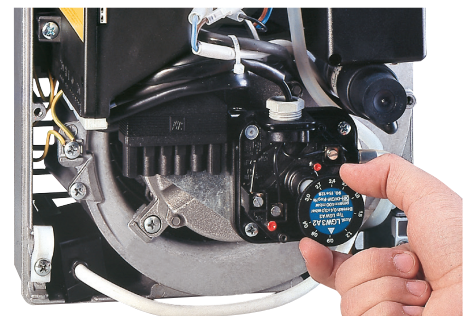

MAINTENANCE AND ELECTRICAL CONNECTIONS

Maintenance is easily solved because the combustion head can be disassembled without having to remove the burner and gas train from the boiler.

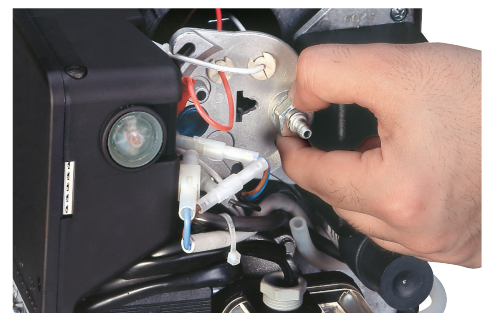

The 7-pole socket is incorporated in the control box, the 6-pole socket for connection to the gas train is already connected to the equipment and fixed to the outside of the burner.

The 7-pin plug is also supplied for connection to the boiler.

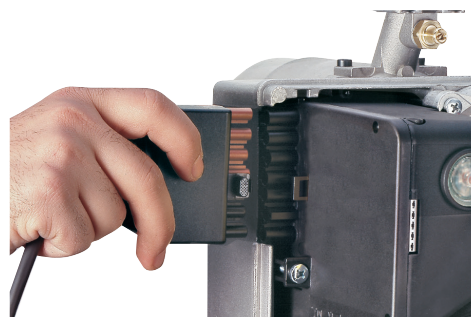
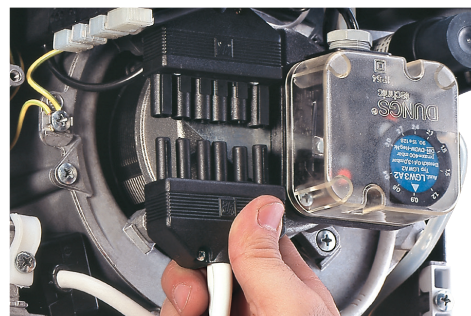

Burner accessories

EXTENDED HEAD KIT

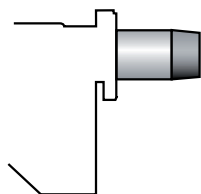

Burners standard head can be transformed into “extended head” versions by using the special kit. Here the KITS available for the various burners are listed, showing the original and the extended lengths.

BURNER	STANDARD HEAD LENGTH (mm)	EXTENDED HEAD LENGTH (mm)	CODE
BS1	70 ÷ 116	70 ÷ 116	20031875
BS2 (long)	100 ÷ 114	170 ÷ 180	3001007
BS2 (extra long)	100 ÷ 114	270 ÷ 280	3001008
BS3	110 ÷ 128	267 ÷ 282	3001009
BS4	145 ÷ 168	302 ÷ 317	3001016

ALTERNATIVE COMBUSTION HEAD KIT

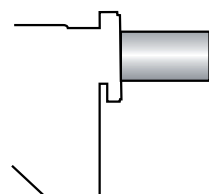

This kit can be used to prevent combustion instability which could arise with particular heat generators.

To extend the adaptability of Gulliver BS burners to any sort of application, alternative combustion heads have been developed.

These heads cause a very limited increase in NOx emissions, due to the slower air flow.

BURNER	CODE
BS1	3001059
BS2	3001064
BS3	3001060
BS4	3001070

PC INTERFACE KIT



To connect the control box to a personal computer for the transmission of operation, fault signals and detailed service information, an interface adapter with PC software are available.

BURNER	CODE
BS1 – BS2 – BS3 – BS4	3002731

7-PIN PLUG KIT

If necessary a 7-pin plug kit is available (in packaging of n. 5 pieces).

BURNER	CODE
BS1 – BS2 – BS3 – BS4	3000945

LPG KIT

For burning LPG gas, a special kit is available to be fitted to the combustion head on the burner, as shown in the following table.

BURNER	HEAD CODE	CODE (*)
BS1	3001003	3002734
BS2	3001004	3002735
BS3	3001005	3002736
BS4	3001011	3002737

(*) CE certification in progress

TOWN GAS KIT

For burning Town Gas, a special kit is available to be fitted to the combustion head on the burner, as shown in the following table.

BURNER	STANDARD HEAD CODE (*)	EXTENDED HEAD CODE (*)
BS1	3002727	-
BS2	3002728	3002728
BS3	3002729	3002729

(*) Without CE certification

GROUND FAULT INTERRUPTER KIT

A "Ground fault interrupter kit" is available as a safety device in case of electrical system fault. It is supplied with burners with pin plug.

BURNER	CODE
BS1 - BS2 - BS3 - BS4	3001180

(*) Without CE certification

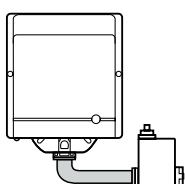
MULTIBLOC ROTATION KIT

There is a special kit available that can be used to install the burner turned 180°. This kit is designed to ensure the gas train valve properly.

BURNER	CODE
BS1	3001179
BS2	3001177
BS3 - BS4	3001178

Gas train accessory

SEAL CONTROL KIT



To test the valve seals on the gas train a special "seal control kit" is available.

GAS TRAIN	CODE for 50Hz operation	CODE for 60Hz operation
MB/1 type	3010123	20050030

Specification

DESIGNATION OF SERIES

A specific index guides your choice of burner from the various models available in the BS series. Below is a clear and detailed specification description of the product.

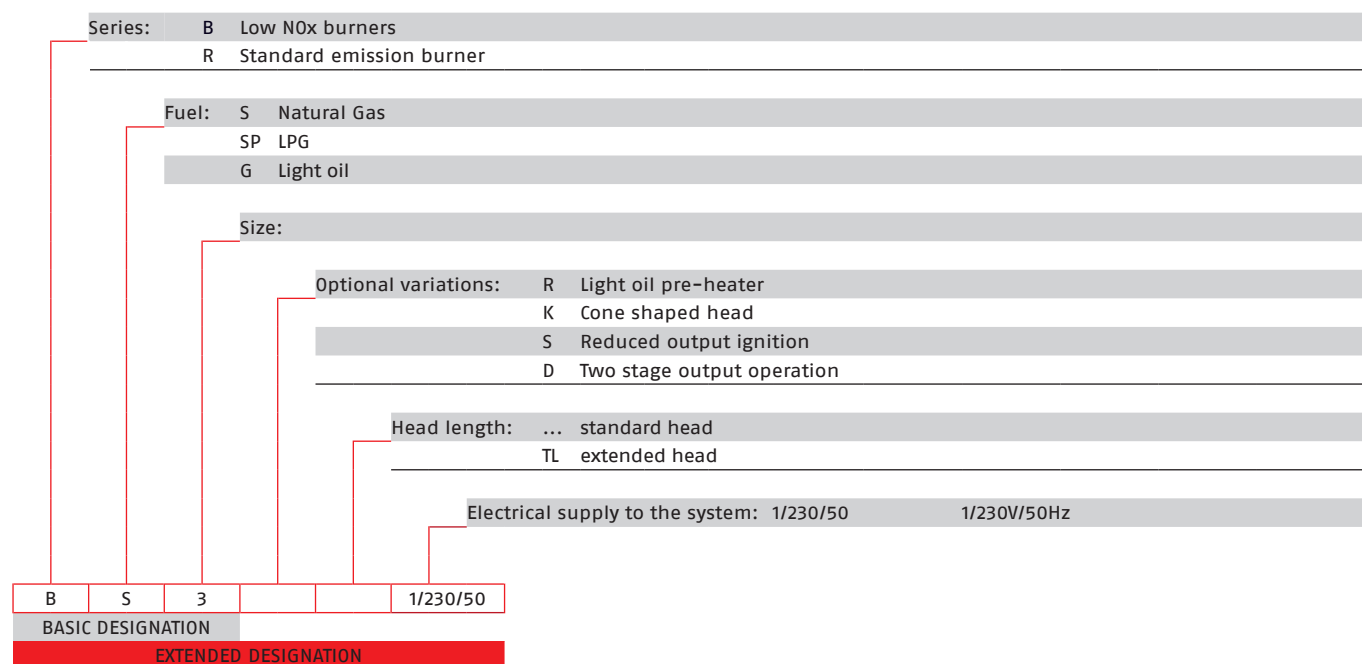

AVAILABLE BURNER MODELS

BURNER MODELS	ELECTRICAL SUPPLY	HEAT OUTPUT		TOTAL ELECTRICAL POWER (kW)	CERTIFICATION	NOTE
		(kW)	NATURAL GAS (Nm ³ /h)			
BS1	1/230/50	16 - 52	1.6 - 5.2	0.15	CE-0085AQ0409	(1)
BS2	1/230/50	35 - 91	3.5 - 9.1	0.18	CE-0085AQ0409	(1)
BS2 TL	1/230/50	35 - 91	3.5 - 9.1	0.18	CE-0085AQ0409	(1)
BS3	1/230/50	65 - 200	6.5 - 20	0.35	CE-0085AQ0409	(1)
BS3 TL	1/230/50	65 - 200	6.5 - 20	0.35	CE-0085AQ0409	(1)
BS4	1/230/50	110 - 250	11 - 25	0.53	CE-0085AQ0409	(1)
BS4 TL	1/230/50	110 - 250	11 - 25	0.53	CE-0085AQ0409	(1)

Net calorific value G20: 10 kWh/Nm³ - Density: 0,71 kg/Nm³.

The burners of BS series are in according to EN 676.

(1) With plug and socket.

SPECIFICATION

STATE OF SUPPLY

Burner

Monoblock, gas burners, completely automatic, one stage operation, made up of:

- fan with forward curve blades
- cover lined with sound-proofing material
- air damper, completely closed in stand by, with external adjustment, with no need to remove the cover
- single phase electric motor 230V, 50Hz
- combustion head fitted with:
 - stainless steel head cone, resistant to high temperatures
 - ignition electrodes
 - ionisation probe
 - gas distributor
 - flame stability disk
- flame inspection window
- adjustable air pressure switch, with graduated selector, to guarantee burner lock out in the case of insufficient combustible air
- microprocessor-based burner safety control box, with diagnostic and remote reset functions
- protection filter against radio interference (included into burner safety control box)
- IP X0D (IP 40) electric protection level

Standard equipment:

- sliding flange
- flange insulation screen
- screws and nuts for fixing the flange to the boiler
- 7-pin plug
- remote control release kit
- instruction handbook for installation, use and maintenance
- spare parts catalogue

Conforming to:

- 2014/30 UE Directive (electromagnetic compatibility)
- 2014/35 UE Directive (low voltage)
- 2009/142 EC Directive (gas)
- 2006/42 EC Directive (machine)
- EN 676 (gas burners)

Available accessories to be ordered separately:

- extended head kit
- alternative extended head kit
- LPG kit
- town gas kit
- ground fault interrupter kit
- Multibloc rotation kit
- 7-pin plug kit
- PC interface kit
- seal control kit

Riello Burners a world of experience in every burner.

07/2016
TS0005UK04



[1]

Across the world, Riello sets the standard in reliable and high efficiency burner technology.

With burner capacity from 5 kW to 48 MW, Riello gas, oil, dual fuel and Low Nox burners deliver unbeatable performance across the full range of residential and commercial heating applications, as well as in industrial processes.

With headquarter in Legnago, Italy, Riello has been manufacturing premium quality burners for over 90 year. The manufacturing plant is equipped with the most innovative systems of assembling lines and modern manufacturing cells for a quick and flexible response to the market.

Besides, the Riello Combustion Research Centre, located in Angiari, Italy, represents one of the most modern facility in Europe and one of the most advanced in the world for the development of the combustion technology.

Today, the company's presence on worldwide markets is distinguished by a well-constructed and efficient sales network, alongside many important Training Centres located in various countries to meet its customers' needs. Riello has 13 operational branches abroad (in Europe, America and Asia), with customers in over 60 countries.



[2]

[1] BURNERS PRODUCTION PLANT
S. PIETRO, LEGNAGO (VERONA) - ITALIA

[2] HEADQUARTER BURNERS DIVISION
S. PIETRO, LEGNAGO (VERONA) - ITALIA

RIELLO S.p.A. - 37045 Legnago (VR) - Italy
tel. +39 0442 630111 - fax: +39 0442 21980
www.riello.com

Since the Company is constantly engaged in the production improvement, the aesthetic and dimensional features, the technical data, the equipment and the accessories can be changed. This document contains confidential and proprietary information of RIELLO S.p.A. Unless authorised, this information shall not be divulged, nor duplicated in whole or in part.

RIELLO