

### Tender specification:

The Oventrop flush-mounted valves "Aquastrom" are straight pattern valves without dead zone for use in potable water systems. Depending on the valve insert, they are used as free-flow valve according to EN1213, as combination free-flow valve / non-return check valve according to EN13959 and W570 or as circulation regulating valve according to VP 554.

PN 10,  $T_{max.}$  90°C,  $P_{open.}$  = 25 mbar,  
max. differential pressure  $\Delta p$  = 1 bar,  
installation in any position.  
DVGW approval applied for.

### Item nos:

Both ports flat sealing male thread according to DIN ISO 228  
DN 15 - DN 20 Item no. 422 60 / 65 04

Both ports female thread according to EN 10226-1  
DN 15 - DN 20 Item no. 422 .. 04 / 06

Both ports press connection system SANHA®  
DN 15 - DN 20 Item no. 422 .. 52 / 53 / 54

### Description and function:

Depending on the valve insert, the flush-mounted valves can be used as free-flow valves (UP-F), or as a combination free-flow valve / non-return check valve (UP-KFR) or as a thermal circulation regulating valve (UP-Therm). All valves are without dead zone. When used as circulation regulating valve, the valve serves to achieve the hydronic balance between the various circulation pipes. If the system calculation according to W553 has been carried out correctly, a cooling down of individual risers will be avoided. The valve also supports thermal disinfection and has an isolation facility.

### Hydronic balancing:

Having reached the factory setting of 57°C or 63°C, the thermal regulating insert limits the flow rate to a residual volume ( $k_v = 0.05$ ). This way, the subsequent circulation risers are also supplied with hot circulation water and a cooling down is avoided. The valve meets the requirements of the test standard VP554. The valve automatically supports thermal disinfection. The volume flow is increased at about 6K above the set temperature and is reduced – irrespective of the set temperature – to the residual volume flow when reaching 73°C.

As the temperature sensor is in direct contact with the fluid, it has a very quick response time to temperature fluctuations. Body and valve inserts made of bronze, O-rings made of EPDM, seals made of PTFE, spring made of stainless steel.

### Installation advice:

Installation of the valve in the direction of flow  
(observe arrow on the valve body).

### Advantages:

#### UP-F / UP-KFR:

- high  $k_v$  values and thus low pressure loss
- silent operation
- no dead zones
- subsequent conversion of "Aquastrom" free flow valves to KFR valves by simply replacing the valve inserts

#### UP-Therm:

- automatic thermal regulation of the flow rate
- support of thermal disinfection
- with isolation facility
- no dead zones
- low hysteresis, as thermometer sensor has direct contact with the fluid



### Dimensions:

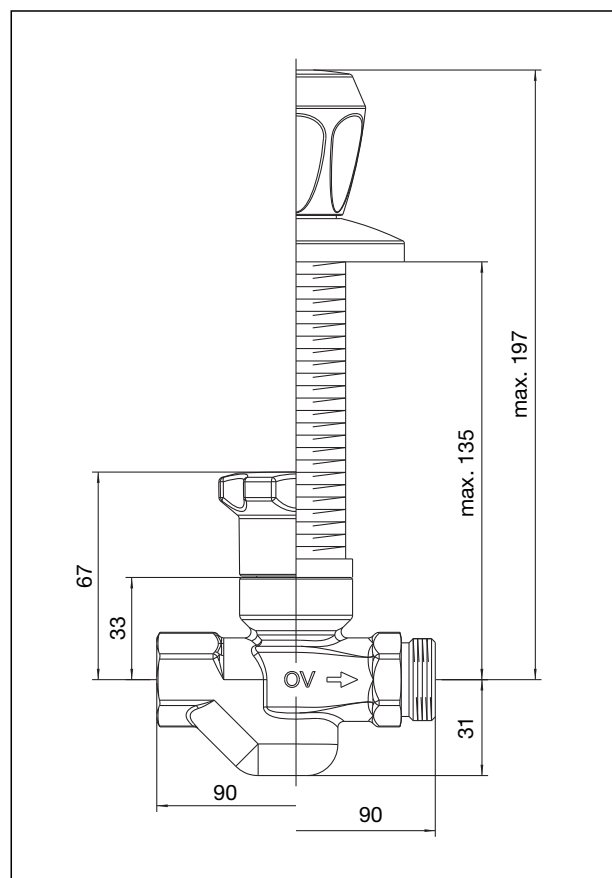

**Flush mounting**

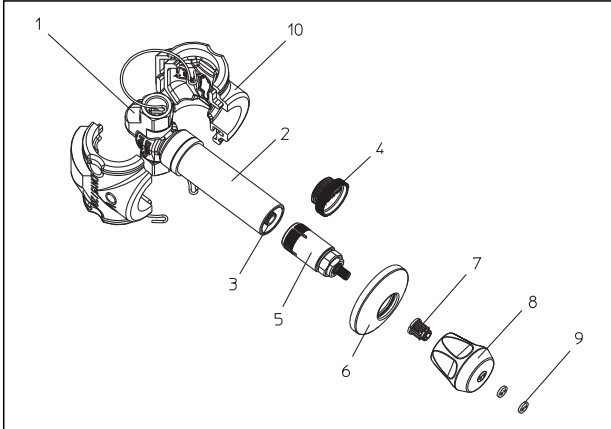

After installation into the pipework, the valve (pos. 1) can be operated with the protection cap (pos. 4) during the construction period. For final installation, remove protection cap and cut off the flush-mounting pipe (pos. 2) and toothed spindle (pos. 3) flush with the wall surface (max. projection of the pipe and the spindle: 7 mm).

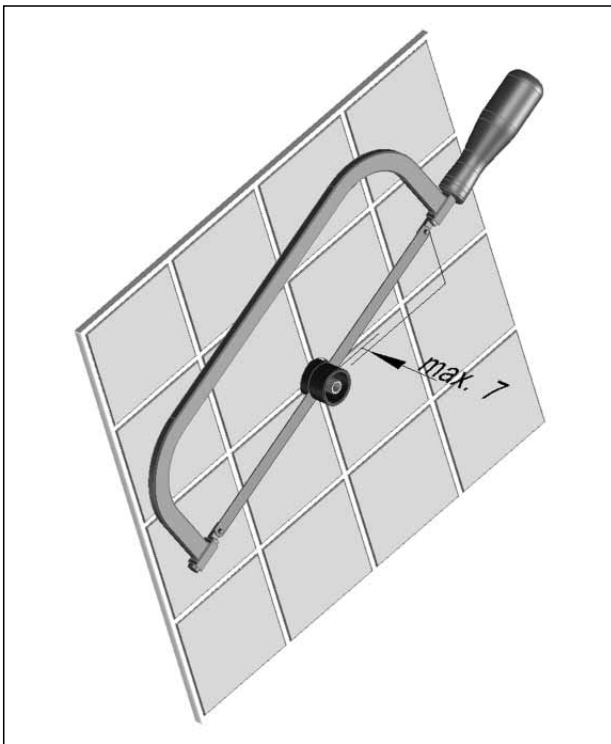

**Note:**

To avoid damage to the brickwork by condensation water, the insulation shells (pos. 10) must always be used!

Now fit clamping bonnet (pos. 5) into the flush-mounting pipe (pos. 2) so that the cogs and the toothed spindle (pos. 3) engage. Tighten clamping bonnet in the flush-mounting pipe by turning nut A (16 mm) clockwise whilst holding still nut B (22 mm).

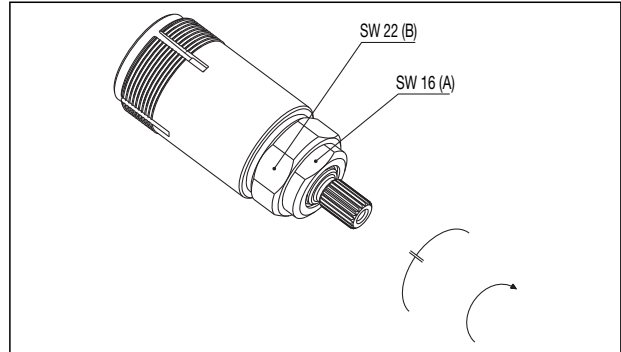

Clamping bonnet

Finally mount chrome-plated rosette cover (pos. 6) onto the clamping bonnet and mount snap-in bush (pos. 7) onto the stem. Fit cap (pos. 9) with the corresponding colour into the handwheel (pos. 8) and press it into the stem until the handwheel engages.

When using the optional lockshield set (422 90 10), the clamping bonnet must be countered with a 22 mm spanner and the clamping piston has to be tightened with an 8 mm Allen key.

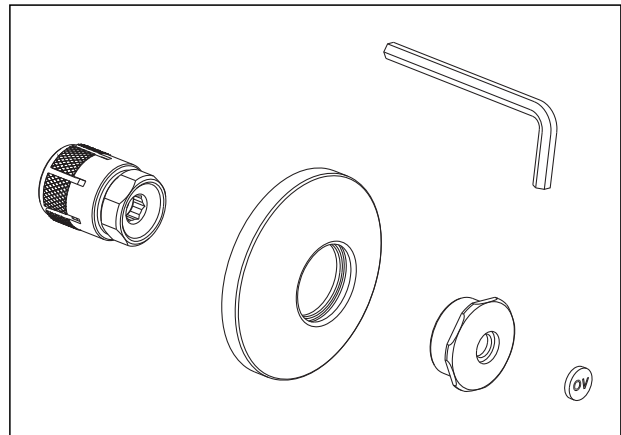

Lockshield bonnet

After removal of the chrome-plated cap, the valve is operated using the 5 mm Allen key included in the delivery.

### Front of wall installation

For installation according to the dry-build system, Oventrop offers the mounting set, item no. 422 90 20.

When used in humid locations (shower, bathroom etc.), the bonded liner (pos. 7) must be placed into the tile adhesive or the wall paper paste after having fixed the valve onto the front of wall construction and after having fixed the gypsum plaster boards. This way, the penetration of water into the flush-mounting construction and the formation of mildew are avoided.

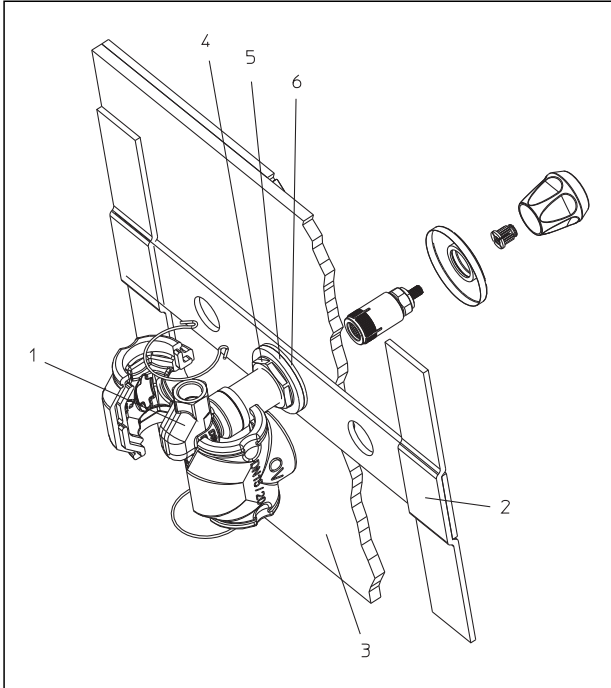

Reverse of front of wall installation

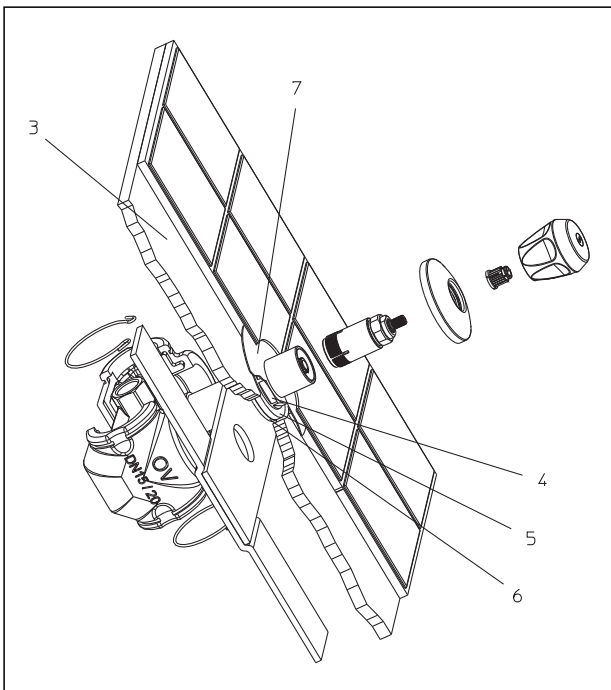

Facing of front of wall installation

- 1 Flush-mounted wall
- 2 Metal front of wall installation
- 3 Gypsum plaster board
- 4 Collar nut
- 5 Washer
- 6 EPDM disc
- 7 Bonded liner

### Maintenance

The mounting adapter, item no. 422 90 30, is available as accessory for the replacement of the valve inserts. To replace the insert, remove the bonnet, once the pipe has been drained off. The valve insert can be removed using the adapter and a commercial set of socket spanners 1/2". The maximum tightening torque of 15 Nm must not be exceeded when installing the new insert!

### Construction and function of the thermal regulating insert (UP-Therm only)

The valve automatically supports thermal disinfection. The volume flow is increased at about 6K above the set temperature and is reduced – irrespective of the set temperature – to the residual volume flow when reaching 73°C. If the temperature drops below the factory setting, the valve opens again.

With the temperature sensor in contact with the fluid, a short response time to temperature fluctuations in the circulation riser and a low hysteresis are guaranteed.

The riser can also be isolated for maintenance and repair when using the "Aquastrom UPTherm" valve.

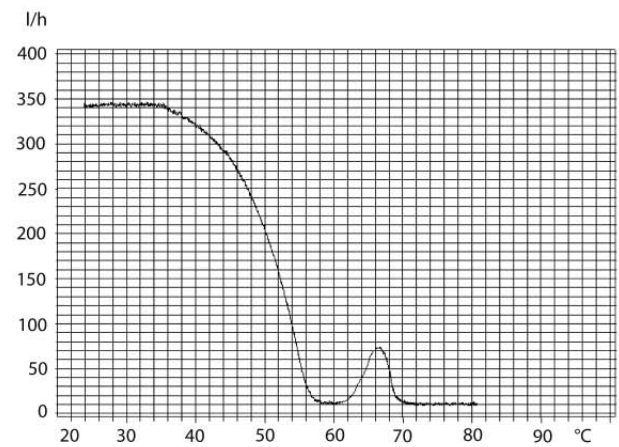

Regulation characteristics UP-Therm

**The valve must be completely opened when putting the circulation riser into operation again!**

**Explanations:**

The pipes are to be flushed thoroughly before initial operation (DIN 1988 part 2 §11.2). The national regulations are to be observed!

A potable water circulation system can be calculated using the Oventrop programme OV-Plan which can be found on the Oventrop CD (available free of charge).

**Note:**

Circulation valves which are sized or set incorrectly, do not ensure a hydronic balancing of the circulation risers. As a result, the return pipes might cool down below the 55°C required by W551 and this in turn presents a risk of germs or legionella development within the system!

To avoid damage to the system, the use of a water softening system is recommended for potable water with a high lime scale.

**Technical data:**

Connections **UP-F/UP-KFR:**

DN 15: G 3/4 M x M  
G 1/2 F x F  
press Ø 15 mm  
press Ø 18 mm

UP-F: kv = 4.8

UP-KFR: kv = 4.8

P<sub>open</sub> = 25 mbar

DN 20: G 1 M x M  
G 3/4 F x F  
press Ø 22 mm

UP-F: kv = 6.3

UP-KFR: kv = 6.2

P<sub>open</sub> = 25 mbar

Materials:  
(in contact with the fluid)

bronze, EPDM, PTFE

Connections **UP-Therm:**

DN 15: G 3/4 M x M  
G 1/2 F x F  
press Ø 15 mm

Temperature setting: 57 °C / 63 °C

(fixed setting)

Residual volume flow: kv = 0.05

Materials: bronze, EPDM, PTFE, VA

(in contact with the fluid)

Fluid: potable water, max. 90 °C

Max. differential pressure Δp: 1 bar

Control accuracy: ±1°C

Installation position: any, but easily accessible

Max. ambient temperature: 90 °C

Working temperature: 0 °C up to 90 °C

Working pressure: 10 bar

Max. test pressure: 16 bar

Max. installation depth: 135 mm

(Tubular axle  
-wall surface)

**Accessories:**

Handwheel set  
Item no. 422 90 01



Lockshield bonnet set  
Item no. 422 90 10



Replacement valve insert for UP-F valve  
Item no. 422 01 90

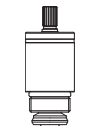

Replacement valve insert for UP-KFR valve  
Item no. 422 10 90

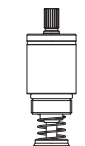

Replacement valve insert  
UP-Therm 57 °C  
Item no. 422 50 90

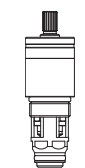

Replacement valve insert  
UP-Therm 63 °C  
Item no. 422 55 90



Mounting adapter  
Item no. 422 90 30



Replacement flush-mounting pipe  
Item no. 422 90 15

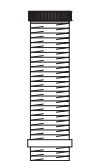

Replacement insulation shell  
DN 15 / DN 20  
Item no. 422 90 50



Mounting set for  
front of wall installation  
Item no. 422 90 20



Oventrop CD  
Item no. 999 99 99  
free of charge



Subject to technical modification without notice.

Product group 12  
ti 236-1/10/MW  
Edition 2009

F. W. OVENTROP GmbH & Co. KG  
Paul-Oventrop-Straße 1  
D-59939 Olsberg  
Telefon +49 (0)2962 82-0  
Telefax +49 (0)2962 82-400  
E-Mail mail@oventrop.de  
Internet www.oventrop.de

For an overview of our global presence  
visit [www.oventrop.de](http://www.oventrop.de).