



The Oventrop Quality Management System is certified to DIN-EN-ISO 9001

Heating oil filter with deaerator "Toc-Duo-N"

Tender specification:

Oventrop heating oil filter with deaerator "Toc-Duo-N" for use in one pipe systems with return flow feed (suction system) for filtering and automatic deaeration of heating oil. Body of deaerator made of metal, with wall bracket and isolating valve. Filter cup and float case made of transparent plastic for function control. Connection for suction pipe to the tank 3/8" female thread for compression fittings 6, 8, 10 or 12 mm (connection sets must be ordered separately). Connection to burner 1/4" female thread or 3/8" male thread with inner taper for hose connection.

"Toc-Duo-N" (burner side 3/8" male thread)

Item no.:	Filter insert:	
214 28 61	Siku	50-75 mm
214 28 62	Siku	25-40 mm
214 28 51	Felt	50-75 mm
214 28 54	opticlean	5-20 mm

"Toc-Duo-N" (burner side 1/4" female thread)

214 28 00	Siku	50-75 mm
-----------	------	----------

"Toc-Duo-N-Magnum" (burner side 3/8" male thread)

214 28 70	Siku M	50-75 mm
214 28 71	Siku M	25-40 mm

Application:

Oventrop heating oil filter with deaerator for use in heating oil installations (suction system) which are operated as one pipe system with return flow feed. A return pipe to the tank is no longer required. The "Toc-Duo-N" serves as a continuous filter and automatic deaerator of the heating oil in heating oil installations.

Technical data:

Connections	
Tank side:	3/8" female thread
Burner side:	3/8" male thread with taper for burner hoses or 1/4" female thread
Fluid: Heating oil type EL according to DIN 51603-1 (09.2003)	
Max. nozzle capacity:	110 l/h
Max. return flow of heating oil:	120 l/h
Deaeration capacity:	min. of 6 l/h air or gas emissions
Installation position:	vertical, deaerator cap pointing upwards
Max. ambient temperature:	60 °C*
Max. working temperature:	60 °C*
Max. working pressure:	0.7 bar corresponding to a static column of oil of 8 m for tanks located at a higher level
Max. suction pressure:	-0.5 bar
Max. test pressure:	6 bar
Dimensions [mm]:	(L x D x H)
"Toc-Duo-N"	161x97x203 (with female thread: 149 x 97 x 203)
"Toc-Duo-N-Magnum"	161 x 97 x 248
TÜV tested:	TÜV Rheinland, No.: S 138 2004 T1

*According to DIN 4755, the max. admissible temperature of heating oil in heating oil installations is 40°C



View burner side:

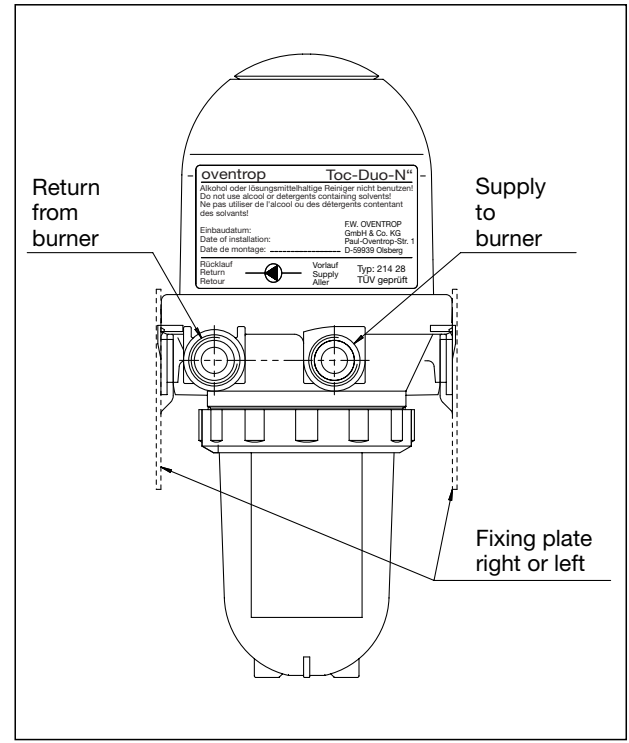

Function:

Oventrop heating oil filter with deaerator for filtering and automatic deaeration of heating oil.

The burner pump draws oil through the suction pipe via the isolating valve, the filter and the check valve. The filter retains dirt particles. Normally, a small portion of oil is pumped to the nozzle by the burner pump and is burnt (per 10 kW of heat output about 1 liter of oil per hour). The excess is fed into the deaerator via the return pipe. Air and gas emissions rise and are expelled into the atmosphere via the float valve. The deaerated oil is fed into the supply via a diaphragm controlled valve. As a result, only the used quantity is drawn from the tank via the suction pipe and the filter. At the same time, the working temperature of the oil pump is used for pre-warming the oil.

Under working conditions, a relatively constant filling height will be present in the lower part of the float case. Depending on the working conditions, this part may even fill up completely.

If heating oil enters the upper part with the security float, the deaerator has to be replaced.

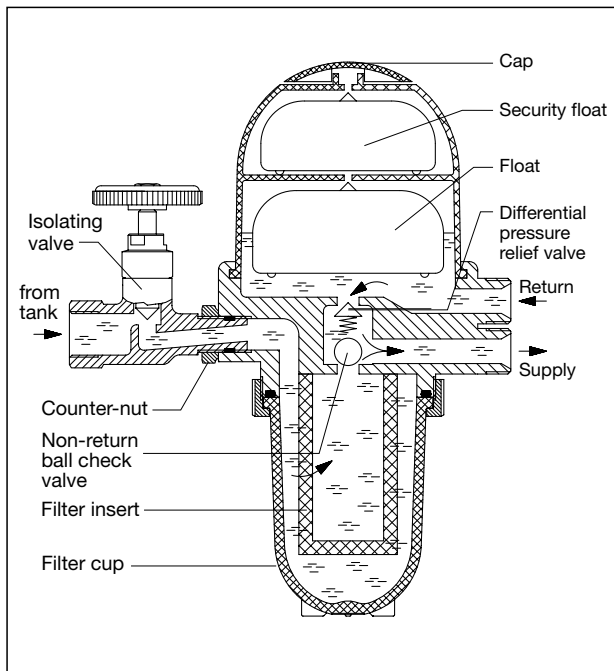
Functional scheme:**Installation:**

Screw isolating valve into the inlet thread of the deaerator, align and counter.

The heating oil filter with deaerator is to be installed at a suitable location with the help of the enclosed fixing plate. To mount the latter on the burner wall by use of the enclosed sheet metal screws, provide 3 mm tapping points. Care should be taken that the max. ambient temperature does not exceed 60°C, i.e. do not mount the "Toc-Duo-N" near an un-isolated part of the boiler or the exhaust pipe or above flaps of the heating which can be opened.

The heating oil filter with deaerator is to be installed vertically.

It can be installed above and below the oil level.

For maintenance and monitoring, the "Toc-Duo-N" should be installed at a location which is well visible and easily accessible.

When converting from two pipe systems to one pipe operation, the pipe dimension has to be reduced if required, see "Sizing of the suction pipe".

If constructional conditions allow, the pipe should be installed in such a way that it acts as a "self-monitoring suction pipe" according to TRbF 50. It should then be installed with an even decline towards the tank and all check valves in front of the "Toc-Duo-N" have to be removed. If leakage occurs, the column of liquid in the declining pipe breaks off.

The supply and return connection must not be mixed up as this may cause damage to the heating oil filter with deaerator and the burner pump.

Pressure test:

When carrying out the pressure test of the suction pipe, the pressure test device must not be connected to the "Toc-Duo-N" as the integrated check valve will prevent the pressure transmission on the tank side.

Moreover, the float valves of a new unfilled "Toc-Duo-N" are opened so that it should not be included in the pressure test.

Notes:

Do not use detergents containing alcohol or solvents as these may damage the plastic parts.

Sizing of the suction pipe:

The suction pipe towards the tank should be sized in such a way that the velocity of the heating oil during burner operation is between 0.2 and 0.5 m/s (DIN 4755). If the suction pipes are oversized, velocity is reduced in such a way that the gas emissions are not transported constantly and gather as big air bubbles in upper sections. If a big air bubble reaches the burner, it may cause a malfunction.

For small burner units in one or two family houses, the inner pipe dimension of 4 mm (e.g. pipe 6 x 1) is often sufficient. Apart from the velocity, the flow resistance and the suction height have to be taken into consideration.

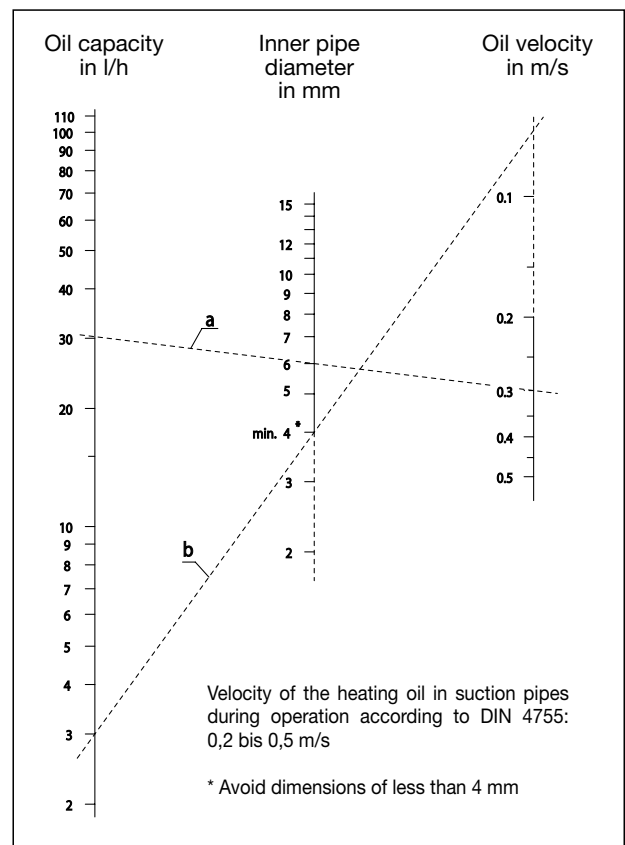
Nomogram:**Examples:**

- For a pump capacity of 30 l/h (about 300 kW), with a medium suction speed of 0.3 m/s, a pipe of 8 x 1 with an inner diameter of 6 mm is required.
- A small installation with a heat output of 30 kW, corresponding to a flow rate of 3 l/h, is equipped with a pipe of 6 x 1 with an inner diameter of 4 mm. The velocity is very low then (about 0.07 m/s), but possible airlocks are very small and do not cause malfunctions.

Examples of installation:

Installation of the "Toc-Duo-N" below the oil level, e.g. battery tank

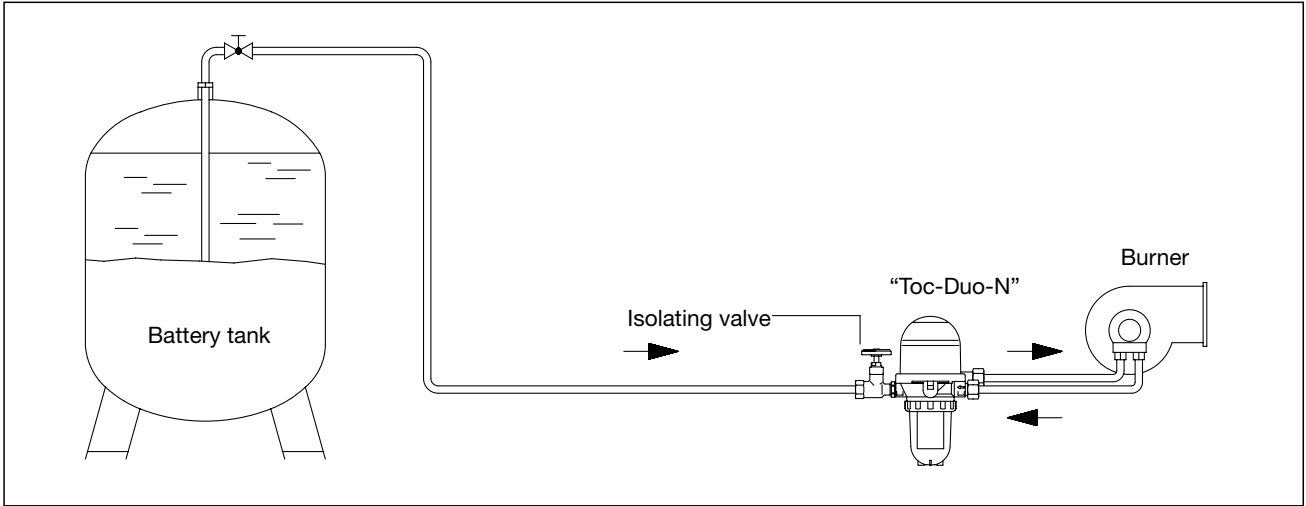

Installation of the "Toc-Duo-N" above the oil level, e.g. underground tank

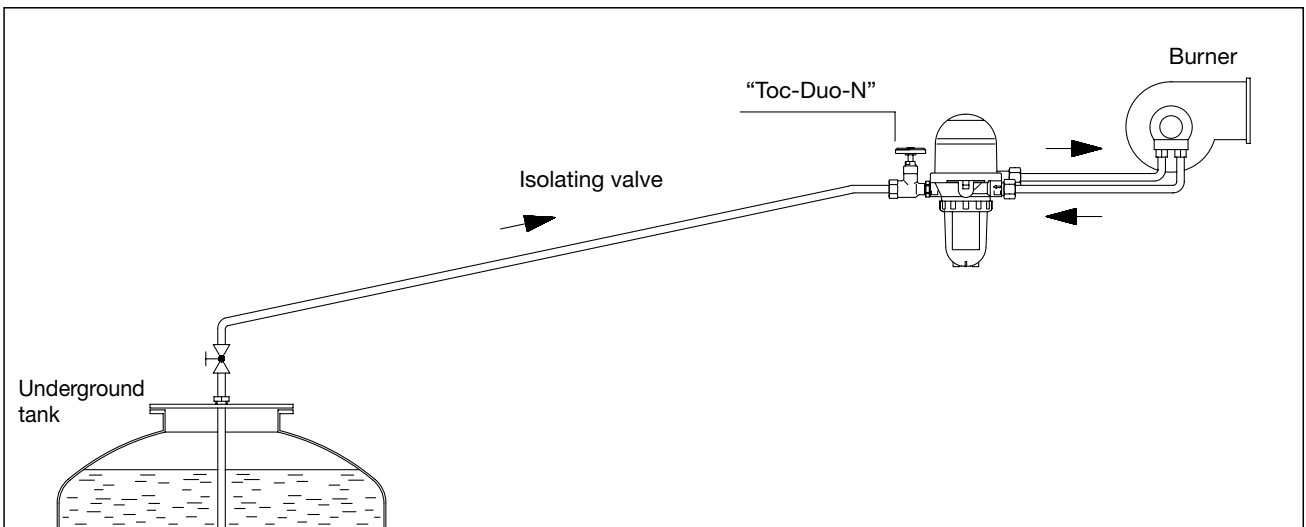

Flow chart:

Pressure loss of the suction system

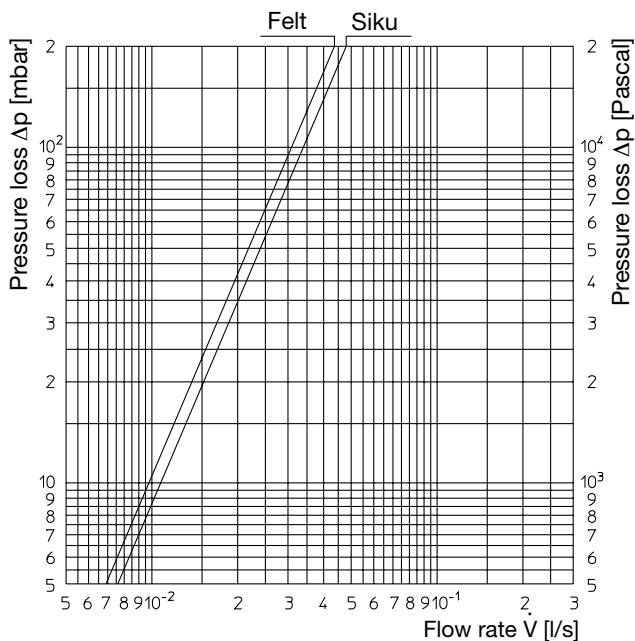

Formation of oil froth and possible malfunctions:

Oil froth may develop if large quantities of air are delivered via the burner pump together with the heating oil. These may lead to malfunctions of the burner.

Possible reasons are:

- leakage in the suction pipe (sealing, re-tighten fittings)
- initial operation of the suction pipe (if required, fill pipe before)
- oversized suction pipe (install smaller size, see "Sizing of suction pipe")

Air pockets in the filter cup:

The heating oil is filtered before deaeration and during this process it is possible that some of the air in the oil is retained by the oil moistened filter insert so that an air pocket forms in the filter cup.

This is especially noticeable where a large portion of air is in the oil. During burner operation, this air cushion is the cause for a sinking oil level in the filter cup when an underlying pressure is built up. However, as the inside of the filter insert is completely filled with oil, the installation continues its operation.

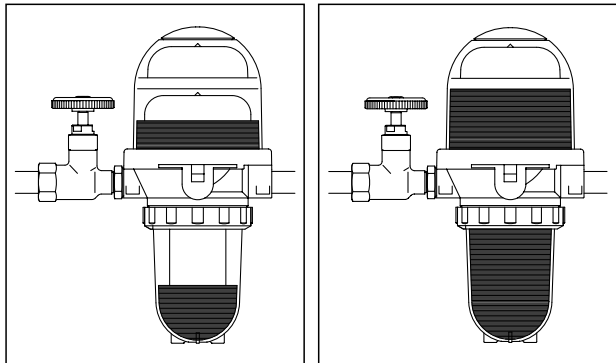

Filling height in the float case:

Depending on the working conditions, different filling heights may develop in the lower float case.

This chamber may also be filled completely, e.g. if no gas emissions exist in case of a tank located at a higher level. The existing air may then dissolve in the heating oil in the circuit between the burner pump and the chamber of the deaerator. If working conditions change, e.g. by a sinking oil level in the tank, a new air cushion may grow.

In case of heating oil in the upper part of the security float, the deaerator has to be replaced.

Parallel installation of several "Toc-Duo-N":

If higher nozzle capacities than 110 l/h are required, it is possible to install two or more heating oil filters with deaerator in parallel. It must be ensured that the maximum return flow feed does not exceed 120 l/h per installed heating oil filter with deaerator. The return flow is the pump output minus the volume of burnt oil.

Pressure operation:

The "Toc-Duo-N" must not be used under pressure, i.e. behind a feed pump in the supply pipe. This is not sensible as air is only emitted in suction operated systems.

According to DIN 4755 it must be ensured that in closed pipe sections a rise in pressure due to an increase in temperature of the heating oil must be balanced off (e.g. by installing a pressure compensation device). Alternatively, closed pipe sections can be avoided by renouncing check valves.

Increased pressure can lead to damage of the heating oil filter with deaerator or other installed equipment.

Flooding:

The Oventrop heating oil filter with deaerator "Toc-Duo-N" may also be installed in areas prone to flooding with the height of flooding not exceeding 5 m.

As dirt may block the vent bores which may lead to malfunctions, a replacement of the "Toc-Duo-N" is recommended after a flooding.

Choice of the filter insert:

Depending on the requirements, different filter insert may be chosen.

The sintered plastic insert (Siku) consists of miniature plastic balls. Its special form offers a larger surface. Possible burner malfunctions caused by erosion of fiber particles are avoided.

Standard: 50-75 mm and 25-40 mm

Magnum (long): 50-75 mm and 25-40 mm

The felt insert proved it's worth over the years.

Standard: 50-75 mm

The filter insert "opticlean" consists of a special paper allowing a very fine filtering with a large surface.

Standard: 5-20 mm

All mentioned filter inserts may not be cleaned and should be replaced at the beginning of each heating period.

All oil pipes must be installed and operated at a frost-free location as oil precipitates paraffin which may block the filter. The finer the filter insert, the more this phenomena applies.

Accessories:

The deaerator expels gas emissions into the atmosphere which may lead to smell nuisances in badly ventilated boiler-rooms. In this case, a hose may be pushed onto a hose nipple and the air may be expelled. Please ensure that the hose is not obturated.



Tested by TÜV Rhineland

F. W. OVENTROP GmbH & Co. KG
Paul-Oventrop-Straße 1
D-59939 Olsberg
Telefon (029 62) 82-0
Telefax (029 62) 82-450
Internet <http://www.owntrop.de>
eMail mail@owntrop.de

OVENTROP UK LTD.
Unit I – The Loddon Centre
Wade Road
Basingstoke, Hampshire RG24 8FL
Telephone (012 56) 33 04 41
Telefax (Sales) (012 56) 33 05 25
Telefax (General) (012 56) 47 09 70
E-Mail sales@owntrop.co.uk

Subject to technical modification without notice.

Product range 8
ti 157-1/10/2004/MW

Printed on paper free from
chlorine bleaching.