



The Oventrop Quality Management System is certified to DIN-EN-ISO 9001

Technical information

Bronze gate valve PN 25 Bronze/brass gate valve PN 25

Tender specification:

Oventrop bronze gate valve according to DIN 3352 standard without draining facility, with handwheel.

Body, bonnet and wedge made of bronze. Non-rising stem made of brass resistant to dezincification (DZR). Stem seal with teflon impregnated gland packing. Threads according to EN 10226 standard with thread runout.

Max. working temperature: 200 °C

Max. working pressure: 25 bar

Oventrop bronze/brass gate valve according to DIN 3352 standard without draining facility, with handwheel.

Body made of bronze. Bonnet, wedge and non-rising stem made of brass, stem seal with teflon impregnated gland packing. Threads according to EN 10226 standard with thread runout.

Max. working temperature: 120°C

Max. working pressure: 25 bar

Function:

Oventrop gate valves made of bronze comply with the DIN 3352 standard. They offer optimum functional efficiency and long service life in all pipework systems for heating and water treatment, in ship, machine and appliance construction as well as chemical industries.

Wide external hexagon sockets with threads according to EN 10226 standard and cylindrical thread runouts provide a trouble-free installation.

The valve body and the one-piece wedge are machined to closest tolerances on special purpose finishing plant, to ensure that the wedge can be turned 180° when the bonnet is removed. The non-rising stem permits a compact structural height. Operation with the help of a strong handwheel.

Advantages:

Corrosion-proof bronze gate valves possess an advantage, when compared with brass valves, if used with media at higher temperature and pressure and when handling liquids otherwise corrosive to brass.

Dimensions:

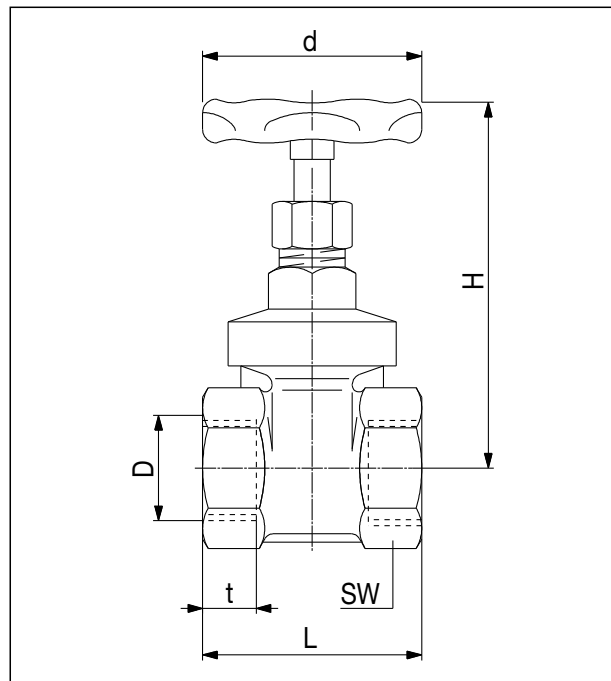

Materials:

Bronze gate valve: Body, bonnet and wedge made of bronze Rg 5. Brass stem resistant to dezincification (DZR), brass gland nut; teflon impregnated gland packing. Handwheel made of sheet steel.

Bronze/brass gate valve: as above, but bonnet, wedge and stem made of brass.

Application:

Bronze gate valve: PN 25 for cold water: water (0 °C - 200 °C), mineral, heating hydraulic oils, diesel oil and other non-aggressive fluids as well as water vapour between 0 °C and 150 °C (the valid rules and standards for the use of these media may restrict the temperature range) as well as air and other harmless and non-aggressive gases*). On size DN 65 and above, CE-marking according to directive 97/23/EG.

*) not for gaseous fluids group 1 according to directive 97/23/EG

Bronze/brass gate valve: Liquids up to 120 °C; water, mineral, heating and hydraulic oils.

Dimensions and item nos.:

DN	D EN 10226	L	t	H	d Ø	kv*	Zeta*	SW* ¹⁾	Weight in gram	Item no. bronze	Item no. bronze/brass
10	3/8"	48	11.4	78	50	10	0.4	24	256	104 30 03	104 10 03
15	1/2"	55	15	80	50	11	0.9	27	304	104 30 04	104 10 04
20	3/4"	60	16.3	89	50	34	0.3	32	381	104 30 06	104 10 06
25	1"	68	19.1	101	60	46	0.4	41	601	104 30 08	104 10 08
32	1 1/4"	76	21.4	118	80	60	0.7	50	987	104 30 10	104 10 10
40	1 1/2"	80	21.4	127	80	105	0.4	58	1219	104 30 12	104 10 12
50	2"	93	25.7	148	90	170	0.4	70	2060	104 30 16	104 10 16
65	2 1/2"	110	30.2	170	100	280	0.5	85	2913	104 30 20	104 10 20
80	3"	120	33.3	208	120	420	0.4	100	4421	104 30 24	104 10 24

* k_{VS} values in m^3/h with Δp 1 bar. Zeta values related to the inside pipe diameter according to DIN 2440 standard.

*¹⁾ SW = spanner size



Tender specification:

Oventrop brass gate valves without draining facility, with hand-wheel.

Body, bonnet and wedge as well as non-rising stem made of brass. Stem seal with teflon impregnated gland packing.

Max. working temperature: 120 °C

Max. working pressure: 25 bar

Function:

Oventrop brass gate valves find use in many applications. They are well-known for their robust construction and clean processing.

The non-rising stem compliments the compact design. Operation with the help of a strong handwheel.

Advantages:

Advantages of the brass gate valve are the competitive price and the compact design.

Materials:

Body, bonnet, wedge, stem and gland nut made of brass; teflon impregnated gland packing. Handwheel made of sheet steel.

Application:

Fluids up to 120 °C, water, mineral, heating and hydraulic oils.

Dimensions:

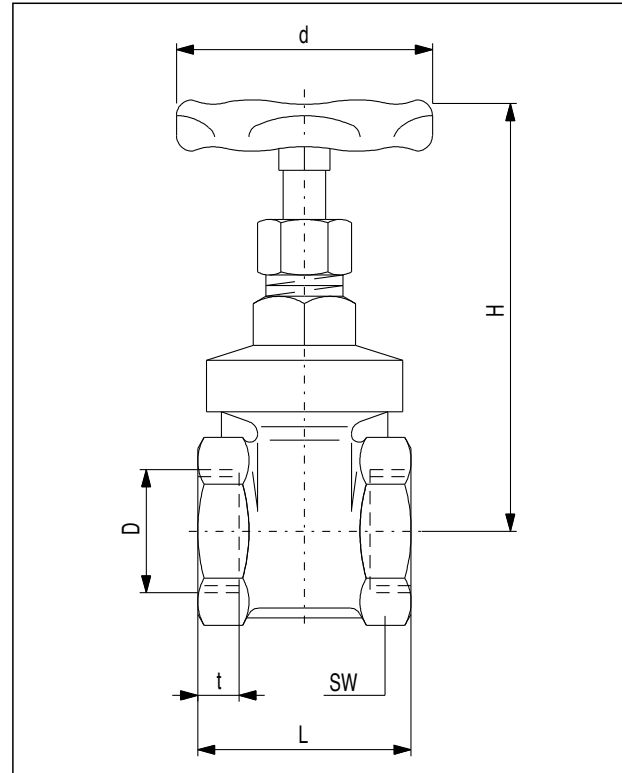

Dimensions and item nos:

DN	D	L	t	H	d Ø	k _{VS} *	Zeta*	SW ^{*1)}	Weight in gram	Item no.
10	3/8"	40	8.5	78	50	10	0.4	22	195	104 00 03
15	1/2"	46	10.5	80	50	11	0.9	26	234	104 00 04
20	3/4"	53	12.5	89	50	34	0.3	31	334	104 00 06
25	1"	60	14	101	60	46	0.4	39	529	104 00 08
32	1 1/4"	64	15	118	80	60	0.7	48	754	104 00 10
40	1 1/2"	72	18	127	80	105	0.4	55	908	104 00 12
50	2"	81	20	148	90	170	0.4	68	1498	104 00 16
65	2 1/2"	90	22	170	100	280	0.5	83	2185	104 00 20
80	3"	98	23	208	120	420	0.4	96	3249	104 00 24
100	4"	118	29	243	120	650	0.4	126	5592	104 00 32

* k_{VS} values in m³/h with Δp 1 bar. Zeta-values related to the inside diameter according to DIN 2440 standard.

SW^{*1)} = spanner size

OVENTROP UK LTD.
 Unit 1 – The Loddon Centre
 Wade Road
 Basingstoke, Hampshire RG24 8FL
 Great Britain
 Telephone (0 12 56) 330441
 Telefax (Sales) (0 12 56) 330525
 Telefax (General) (0 12 56) 470970
 E-Mail sales@oventrop.co.uk

OVENTROP GmbH & Co. KG
 Paul-Oventrop-Straße 1
 D-59939 Olsberg
 Telefon +49 (0) 29 62 82-0
 Telefax +49 (0) 29 62 82-450
 E-Mail mail@oventrop.de
 Internet www.oventrop.de

Subject to technical modification without notice.

Printed on paper free from chlorine bleaching.