

Application:

The combined control and regulating valve "Cocon QTR" is designed to be installed in heating and cooling systems with a closed water circuit (e.g. central or underfloor heating systems, fan coil units, chilled ceilings, fan convectors etc.) for an automatic flow control (hydraulic balancing) and room temperature control by modifying the flow rate in conjunction with actuators.

Technical data:

Performance data

Max. operating temperature: 120 °C
 Min. operating temperature: -20 °C
 Max. operating pressure: 16 bar (1600 kPa)
 Max. differential pressure: 4 bar (400 kPa)
 Fluid: Water or mixtures of water and ethylene/propylene-glycol (max. 50%), pH value 6.5-10

Control range:

Item no.	DN	Control range [m ³ /h] (min.*-max.)	K _{vs} value	Differential pressure p1-p3 (min.-max.)
114 61 12	40	1.5 - 7.5	11.5	0.2 bar-4 bar (20 kPa-400 kPa)
114 61 72	40	1.5 - 7.5	11.5	
114 61 16	50	2.5 - 10.0	15.0	
114 61 74	50	2.5 - 10.0	15.0	

* Recommended lowest setting; starting from the set value, the flow rate can be reduced up to complete isolation.

Materials:

Bronze body, seals made of EPDM or PTFE, inner parts made of DZR brass, maintenance-free stem seal due to double O-ring.

Model:

Measuring technique "classic", both ports female thread according to EN 10226 or both ports male thread

Function:

The Oventrop valve "Cocon QTR" is a valve combination consisting of an automatic flow regulator (with manually adjustable nominal value) and a regulating valve which may be equipped with an actuator.

Advantages:

- the nominal values can be set even with the actuator in place
- the set nominal value can be read off even with the actuator in place
- good optical display of the presetting values in different installation positions
- nominal values can be read off in [m³/h] without conversion
- lockable and lead lockable presetting
- constant, high valve authority
- optimisation of the installation by control pressure measurement
- linear characteristic line is actuator driven

Accessories:

Lead locking set 108 90 91



Legend:

1. Diaphragm unit
2. Control unit
3. Flow unit

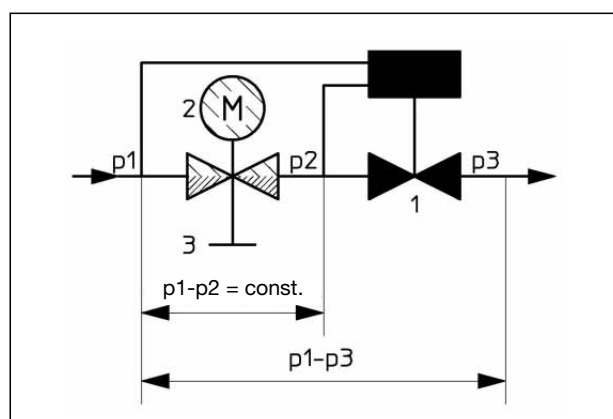
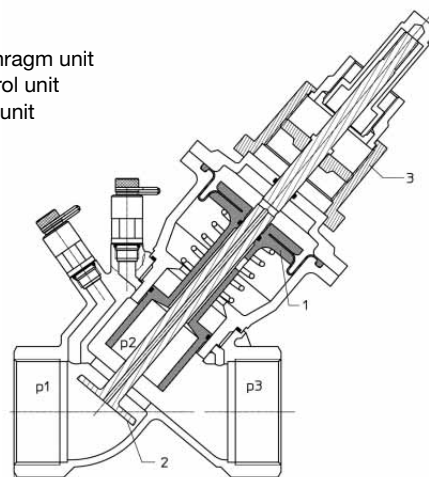

The illustrated section of the combined control and regulating valve "Cocon QTR" shows three pressure ranges. "p1" is the inlet and "p3" the outlet pressure of the valve. "p2" is the pressure actuating the diaphragm unit and maintaining the differential pressure "p1" - "p2" at a constant level.

The combined control and regulating valve "Cocon QTR" combines the functions of three valves. The integrated diaphragm unit (pos. 1) acts as a differential regulator and guarantees a constant pressure regulation of the differential pressure "p1" - "p2" across the second valve (regulating valve activated through the actuator - pos. 2) and across the third valve (manually adjustable flow unit - pos. 3).

Even where high differential pressure variations "p1" – "p3" occur, e.g. if sections of the system are activated or inactivated, the differential pressure "p1" – "p2" is kept at a constant level.

This way, the combined control and regulating valves "Cocon QTR" have a valve authority of 100% (a = 1). Even during low demand periods with steady control (e.g. in conjunction with 0-10 V actuators), the valve authority of the regulating valve "Cocon QTR" within the effective valve lift amounts to 100% (a = 1).

The "Cocon QTR" valve has a linear characteristic line within the effective valve lift and is advantageous when using actuators which also have a linear stroke behaviour.

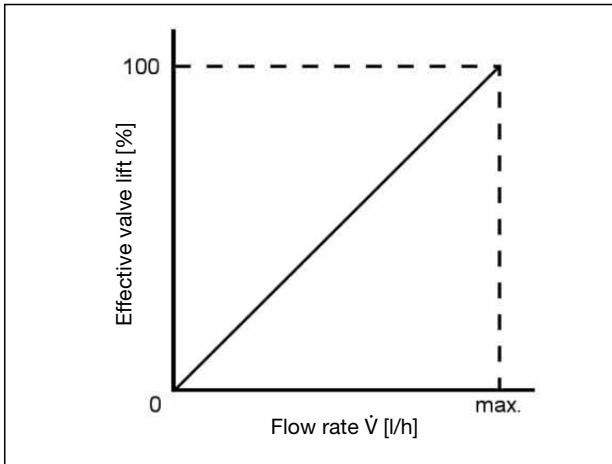

Illustr. 1: Characteristic line of the combined control regulating valve "Cocon QTR"

Application:

Oventrop combined control and regulating valves "Cocon QTR" are used in central heating systems and chilled ceilings with circulation pump for flow and room temperature control.

The combined control and regulating valves "Cocon QTR" can be used in conjunction with the following Oventrop actuators: The setting sleeve (spanner size 17 mm) has to be unscrewed.

The installation instructions supplied with the actuator have to be observed!

Models:

Models:	Item no.
Actuator with squeeze connection 24 V, steady control 0-10 V	115 80 10
Actuator with squeeze connection 24 V, steady control 0-10 V and 4-20 mA	115 80 30
Actuator with squeeze connection 24 V, steady control 0-10 V and 4-20 mA, with spring return	115 80 31

Setting of the flow rate:

The required flow rate can be set with the help of the handwheel and the setting sleeve (illustr. 2).

The setting can only be modified after releasing the setting sleeve.

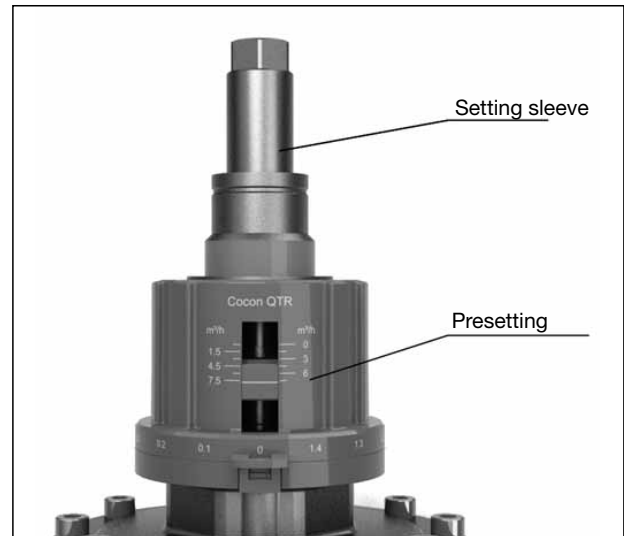

Illustr. 2: Setting sleeve

Protection and locking:

The presetting can be secured and lead locked with a locking clip.

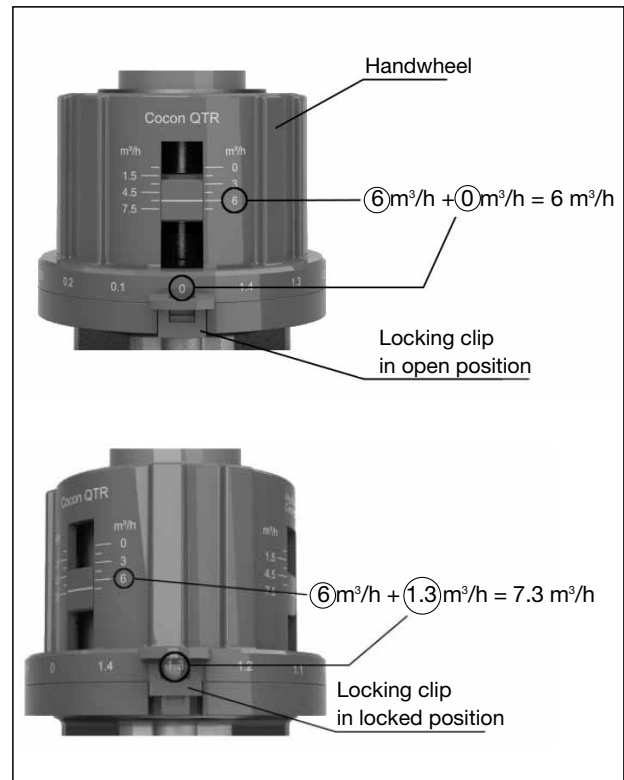

Illustr. 3: Example settings

Dimensions

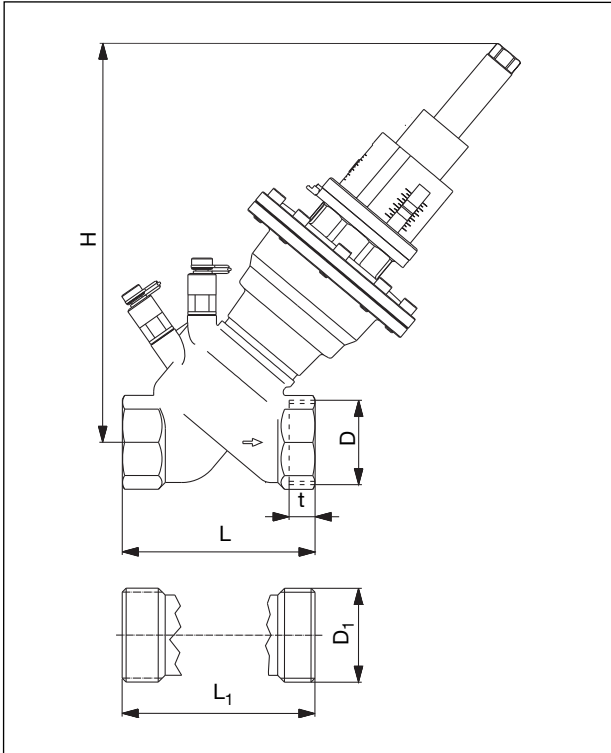

DN	D	D ₁	L	L ₁	t	H
40	Rp 1½	–	120	–	19.1	245
	–	G 1¾	–	120	–	245
50	Rp 2	–	150	–	25.7	255
	–	G 2⅝	–	150	–	255

Installation:

- the direction of flow must conform to the arrow on the valve body
- the valve may be installed in any position (electric actuators may not be installed vertically downwards)
- do not use any lubricant or oil when installing the valve as these may destroy the valve seals; if necessary, all dirt particles and lubricant or oil residues must be removed from the pipework by flushing the latter
- any tension which could be transferred through the pipework must be avoided
- when choosing the operating fluid, the latest technical development has to be considered (e.g. VDI 2035)
- a strainer in front of the valve as well as isolating valves for maintenance are to be installed in front and behind the valve
- the correction factors of the manufacturers of the antifreeze liquids have to be considered when setting the flow rate
- once installation is completed, check all installation points for leaks

Min. differential pressure p₁-p₃ for valve design:

The minimum required differential pressure p₁-p₃ across the valve can be taken from the following chart.

Explanation regarding the chart:

For valves with integrated flow control, the required minimum differential pressure varies depending on the set nominal value. The relevant mathematical correlation has taken into account the chart.

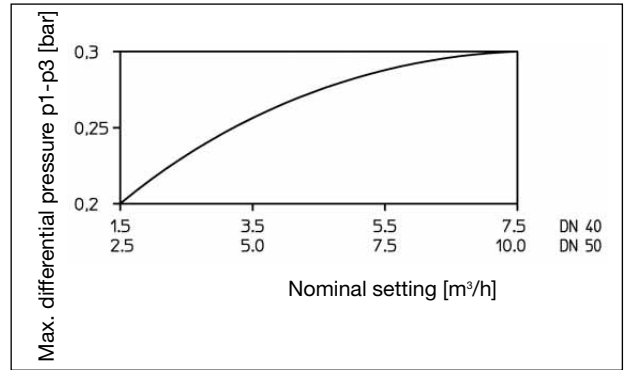

Illustr. 4: Max. differential pressure 4 bar (400 kPa)

Pressure test points:

The flow-meter "OV-DMC 2" can be connected to the pressure test points. This will determine if the valve is working within the control range. The pump setting can be optimised by measuring the differential pressure.

For this purpose, the pump head is reduced until the hydraulically underprivileged valves are just working within the control range. The minimum differential pressures according to illustration 4 have to be considered. As soon as the measured differential pressure is identical with or higher than the minimum differential pressure p₁-p₃ according to illustration 4, the valve is working within the control range.

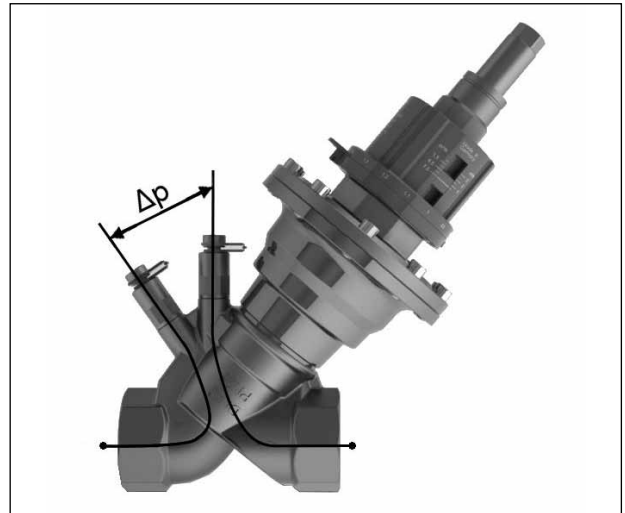

Illustr. 5: Differential pressure

With a flow-meter connected (e.g. "OV-DMC 2"), the differential pressure (p₁-p₃) is measured across the valve.

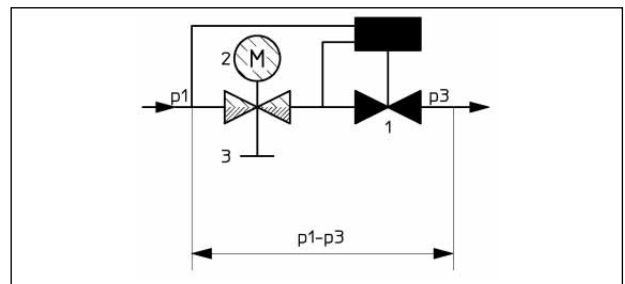

Illustr. 6: Basic illustration for differential pressure measurement

Subject to technical modification without notice.

Product range 3
ti 238-1/10/MW
Edition 2011

OVENTROP GmbH & Co. KG
Paul-Oventrop-Straße 1
D-59939 Olsberg
Phone +49 (0)29 62 82-0
Telefax +49 (0)29 62 82-450
E-Mail mail@oventrop.de
Internet www.oventrop.com