



The Oventrop Quality Management System is certified to DIN-EN-ISO 9001

## Regulating valve “Cocon” Measuring technique “eco” and “classic”

### Tender specification:

Oventrop regulating valves “Cocon” with proportional presetting with memory position, with draining, filling and isolating facility with metering station for flow measurement and with linear characteristic line for  $k_{VS}$  0.45 and 1.0. Body made of unplated brass (DN 15) or bronze (DN 20), valve disc made of EPDM or PTFE, O-rings made of EPDM, stem of the regulating insert made of stainless steel.

Connection thread M 30 x 1.5.

Complete valve insert of size DN 15 replaceable under working conditions by use of the special tool “Demo-Bloc”.

Connection for threaded pipes, copper, plastic, stainless steel or precision steel pipes as well as Oventrop composition pipe “Copipe”.

Max. working temperature: 120 °C

Min. working temperature: - 10 °C

Max. working pressure: 10 bar

Max. differential pressure: 1 bar

The regulating valves “Cocon” are designed for four ranges of mass flow:

### Item nos.:

Inlet port: ½" coupling, Outlet port: ½" female thread:

	“eco”	“classic”	$k_{VS}$	$k_V$ value of integrated measuring orifice	Marking on gland and protection cap
DN 15 (½")	114 50 04	114 50 74	$k_{VS} = 0.45$	0.46	P 1
DN 15 (½")	114 51 04	114 51 74	$k_{VS} = 1.0$	1.16	P 2
DN 15 (½")	114 52 04	114 52 74	$k_{VS} = 1.8$	3.00	P 3

Inlet and outlet port: ¾" female thread with taper:

	“eco”	“classic”	$k_{VS}$	$k_V$ value of integrated measuring orifice	Marking on gland and protection cap
DN 15 (½")	114 53 61	114 53 71	$k_{VS} = 0.45$	0.46	P 1
DN 15 (½")	114 53 62	114 53 72	$k_{VS} = 1.0$	1.16	P 2
DN 15 (½")	114 53 63	114 53 73	$k_{VS} = 1.8$	3.00	P 3
DN 20 (¾")	114 54 65	114 54 75	$k_{VS} = 4.5$	5.50	

### Application:

Closed systems like cooling systems, Fan-Coil units and central heating systems.

### Function:

The Oventrop regulating valves “Cocon” control the room temperature by changing the flow rate with the help of actuators. The valves are installed in the return pipe of chilled ceiling modules e.g. To carry out the hydronic balance of a chilled ceiling installation, a presetting for the modification of the flow resistance can be carried out. The set value can be reproduced. The required values can be taken from the flow charts.

The regulation of the installation is carried out via the pressure test points of the Oventrop flow meter “OV-DMC 2” or the Oventrop differential pressure gauge.

Filling and draining of the chilled ceiling module is carried out with the help of the service tool (filling and draining tool), item no. 109 05 51 or alternatively item no. 106 17 91 for “Cocon” valves with measuring technique “eco”.



### Advantages:

- easy installation and servicing
- only one valve for 6 functions
  - regulating
  - presetting
  - measuring
  - isolating
  - filling
  - draining/bleeding
- exact hydronic balance of the installation
- infinitely adjustable presetting
- exact control of the flow rate by use of the pressure test points
- regulating insert of size DN 15 replaceable under working conditions
- linear characteristic lines for  $k_{VS}$  0.45 and 1.0

### Accessories:

- Tailpipe sets
- Compression fittings “Ofix”
- Draining and filling tools
- Measuring device (measuring technique “eco”)
- Measuring needles

### Actuators:

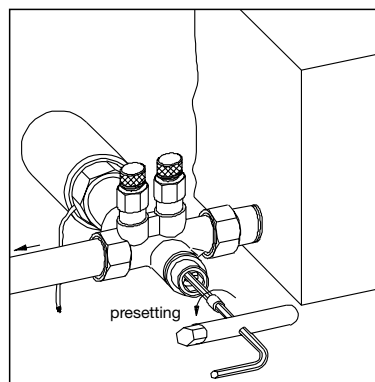
Actuator	Voltage	Control		
		Two point	Three point	Proportional
Electro-thermal	24 V	1012486		1012951 (0-10 V)
	230 V	101 24 85/87/89		
Electro-motive	24 V	101 27 01	101 27 01	1012700 (0-10V)
	230 V	1012710	101 27 03	
	EIB			115 60 65/66
	LON			115 70 65

**Presetting:**

- 1 Unscrew protection cap.
- 2 Close the valve disc by turning a 4 mm spanner clockwise.
- 3 Then preset the valve disc by turning the 4 mm spanner anticlockwise according to the number of turns selected from the flow chart (illustr. 1).
- 4 Finally, using a screwdriver, turn the lock nut clockwise until stop (illustr. 2).

**Important:** In case of subsequent modification of the presetting, the lock nut should first be unscrewed by turning a screwdriver (illustr. 2) slightly anticlockwise. Afterwards the presetting can be changed by use of the 4 mm spanner.

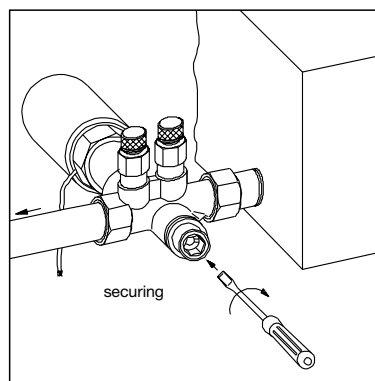
**Note:** The chosen presetting will not be changed by draining or isolating the chilled ceiling module.



Illustr. 1

**Isolating:**

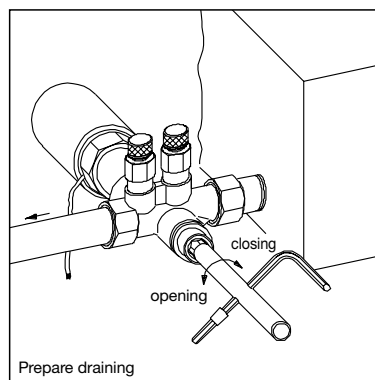
- 1 Unscrew protection cap.
- 2 Close the valve disc by turning a 4 mm spanner clockwise.
  - Attention:** Do not twist the lock nut as otherwise the chosen presetting is no longer given when opening the valve.



Illustr. 2

**Draining/bleeding:**

- 1 Close the valve in the supply pipe of the chilled ceiling module (only for draining operation).
- 2 Isolate the valve as described under point 2 (only for draining operation).
- 3 Loosen the valve insert by turning a 10 mm spanner anticlockwise (max. ¼ thread) (illustr. 3).
  - Attention:** The lock nut has to be screwed in sufficiently so that the 10 mm spanner can be inserted to a depth of at least 4 mm.
- 4 Fit the service tool to the valve and connect a ½" hose (illustr. 4).
  - Attention:** Tighten the 19 mm compression nut closely (max. 10 Nm).
- 5 Fit the 10 mm spanner to the service tool and drain or bleed the chilled ceiling module by turning anticlockwise (illustr. 4).



Illustr. 3

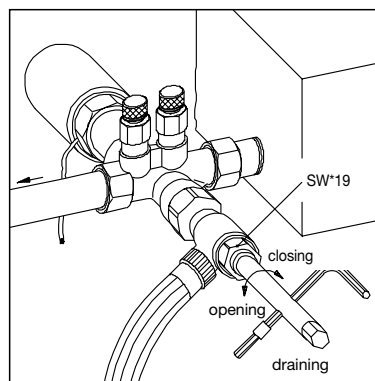
**Filling:**

via the service tool:

- 1 If the chilled ceiling module was drained with the help of the service tool, no modifications to the tool or the valve are required. The chilled ceiling module can now be filled through the connected ½" hose.
- 2 With the filling operation completed, fit the 10 mm spanner to the service tool again and close the insert by turning clockwise (illustr. 4).
- 3 Remove the service tool and tighten insert using the 10 mm spanner (max. 10 Nm) (illustr. 3).

via the system:

- 4 Close the valve by turning the insert clockwise with a 10 mm spanner and tighten it (max. 10 Nm) (illustr. 3).
- 5 Open the valve disc by turning a 4 mm spanner anticlockwise.
- 6 Replace protection cap.
- 7 The chilled ceiling module has to be bled.

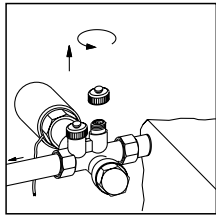


Illustr. 4

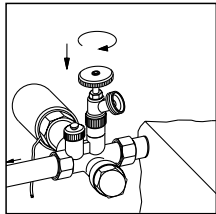
\* SW = Spanner size

**Draining/bleeding/filling via the service tool, item no. 106 17 99.**

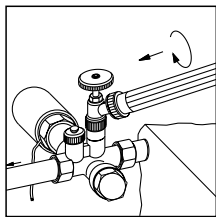
**Important: Only for “Cocon” valves with measuring technique “eco”.**



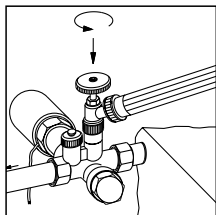
1 Unscrew protection cap.



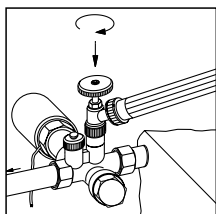
2 Fit service tool.



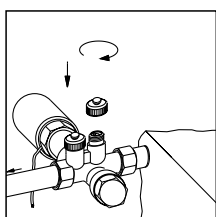
3 Connect hose.



4 Press handwheel downwards while turning it anticlockwise. Note: First, the stem engages, then the valve opens for draining or filling.



5 For isolation, press handwheel downwards while turning it clockwise.



6 Having completed the operation, unscrew hose and service tool and remount protection cap.

**Designation of the presetting values for the hydronic balance of the installation**

The flow rates and flow resistances of the individual chilled ceiling modules result from the design calculation for a chilled ceiling installation. Accordingly the flow rate  $q_m$  and the pressure loss  $\Delta p$  for each chilled ceiling module have to be set exactly at the regulating valve “Cocon” to guarantee an even supply of coolant to all modules.

To do so, the design point is searched for in the charts 3, 5, 7 or 9 (depending on the chosen  $k_{VS}$  value) with the help of the values  $\Delta p$  and  $q_m$ . The required number of turns is taken from the chart and the valve disc is opened accordingly at the presetting of the regulating valve (procedure see chapter “Presetting”).

**Control of the hydronic balance within the chilled ceiling installation**

Should a control of the flow values in the chilled ceiling modules become necessary, this can be achieved by using the pressure test points integrated in the regulating valves. The measuring needles of the Oventrop flow meter “OV-DMC 2” may be inserted into these pressure test points.

**Behaviour during low demand periods**

For the regulation of the chilled ceiling installation during low demand periods, the regulating valves “Cocon” have to be equipped with actuators (see chapter “Function”) operating the valve inserts which vary the flow rates of the coolant within the chilled ceiling modules. The charts 4, 6, 8 and 10 illustrate the working range of the regulating valves depending on the piston stroke of the four valve inserts ( $k_{VS} = 0.45$ ,  $k_{VS} = 1.0$ ,  $k_{VS} = 1.8$  and  $k_{VS} = 4.5$ ). It has to be considered that these values including the noise characteristic lines 25 dB(A) and 30 dB(A) are only valid for the presetting being completely opened. This is why the charts only give information on the working range of the regulating valves with maximum flow rates.

**Correction factors for mixtures of water and glycol**

1 Calculation with given flow rate

When anti freeze liquids are added to the coolant, the pressure loss given in the chart must be multiplied by the correction factor (charts 1/2).

$$\Delta p_{\text{mixture}} = \Delta p_{\text{chart}} \cdot f$$

2 Calculation with given or measured pressure loss

When anti freeze liquids are added to the coolant, the measured pressure loss must be divided by the correction factor  $f$ .

$$\Delta p_{\text{chart}} = \Delta p_{\text{mixture}} : f$$

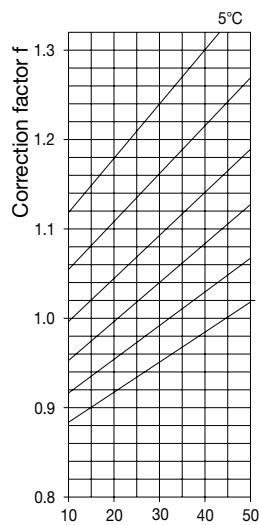
The flow rate can be read off chart 10 with the help of the calculated  $\Delta p_{\text{chart}}$ .

3 Calculation with measured flow rate

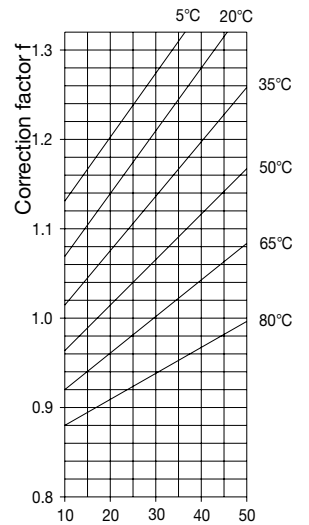
( $q_m$  measured) with “OV-DMC 2”

$$q_{m\text{mixture}} = q_{m\text{measured}} : \sqrt{f}$$

**Chart 1:**



**Chart 2:**



Weight proportion of ethylene glycol [%]

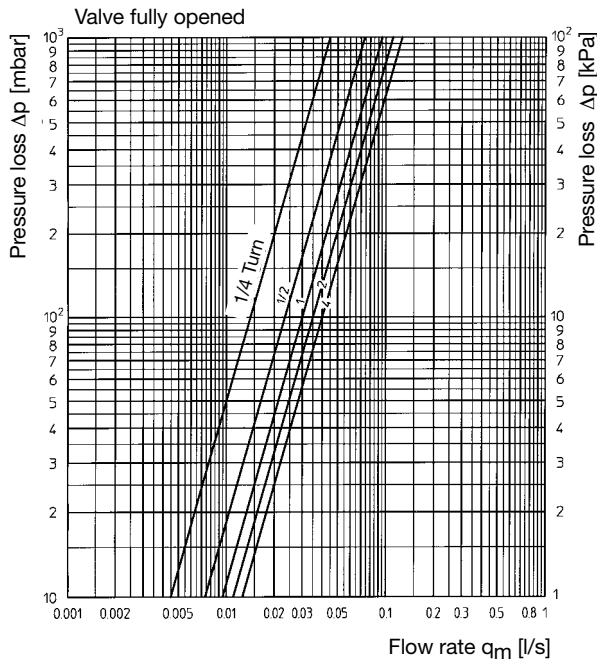
Weight proportion of propylene glycol [%]

When using the flow meter “OV-DMC 2”, only the percentage of the glycol mixture has to be entered. The conversion is carried out by the computer.

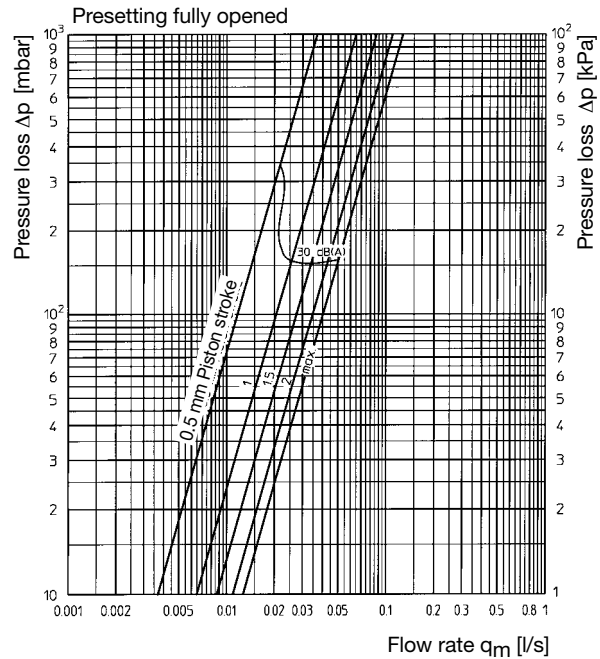
Flow rate depending on the pressure loss ( $\Delta p$ ) and the presetting of the valve (charts 3, 5 and 7):

Item nos. 114 50 04, 114 53 61, 114 50 74 and 114 53 71,  $k_{VS} = 0.45$

**Chart 3**

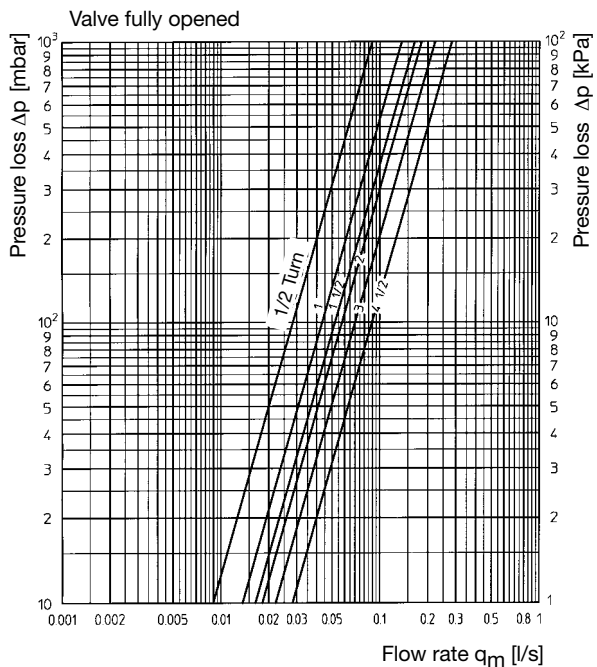


**Chart 4**

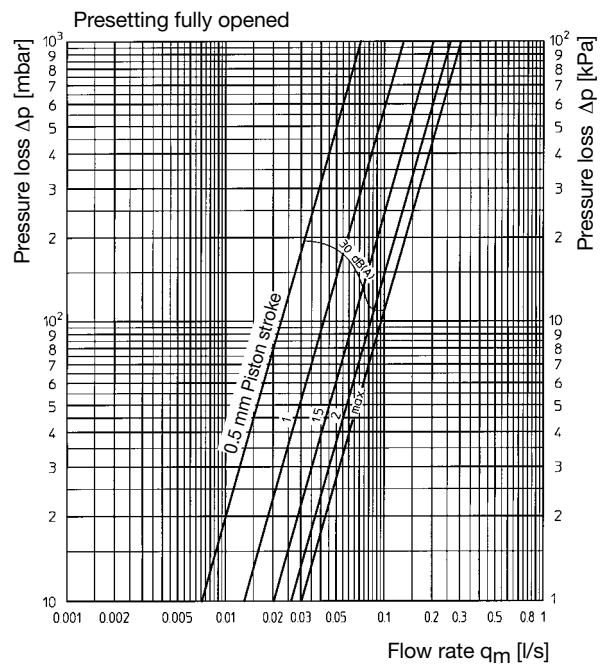


Art.-Nr. 114 51 04, 114 53 62, 114 51 74, 114 53 72,  $k_{VS} = 1,0$

**Chart 5**



**Chart 6**



Performance data (all models) when used in conjunction with thermostats (e.g. “Uni XH”, “Uni LH”)

Presetting fully opened

Size	$k_{VS}$ value	$k_V$ at P-deviation			
		1 K	2 K	3 K	4 K
DN 15	0.45	0.05	0.10	0.15	0.20
DN 15	1.0	0.095	0.17	0.25	0.33
DN 15	1.8	0.5	1.0	1.3	1.5
DN 20	4.5	0.6	1.2	1.75	2.1

Item nos. 114 52 04, 114 53 63, 114 52 74, 114 53 73,  $k_{VS} = 1.8$   
Chart 7

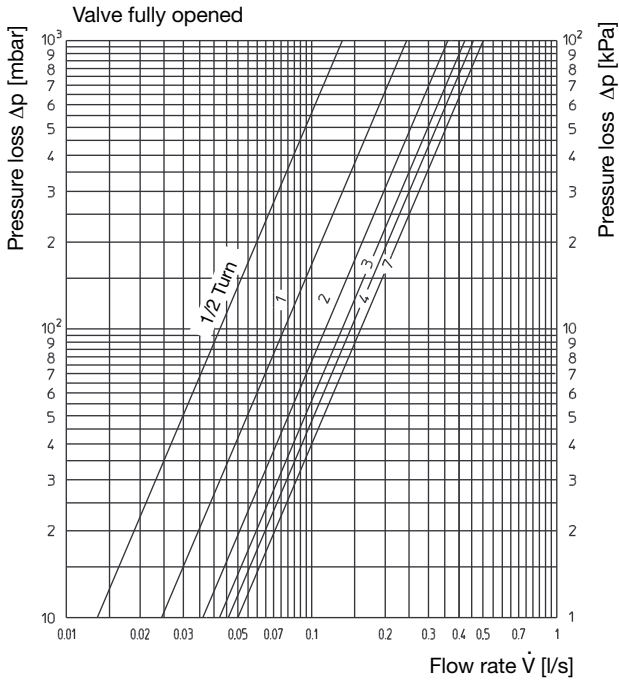
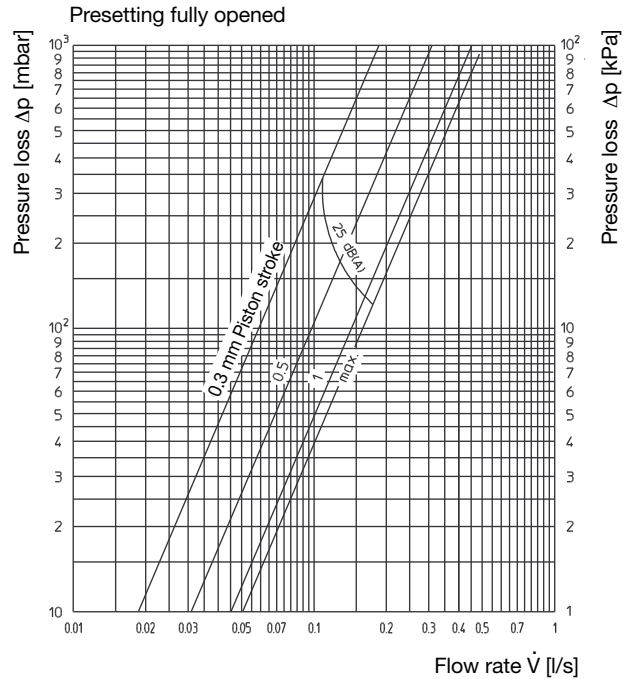


Chart 8



Item nos. 114 54 65, 114 54 75,  $k_{VS} = 4.5$

Chart 9

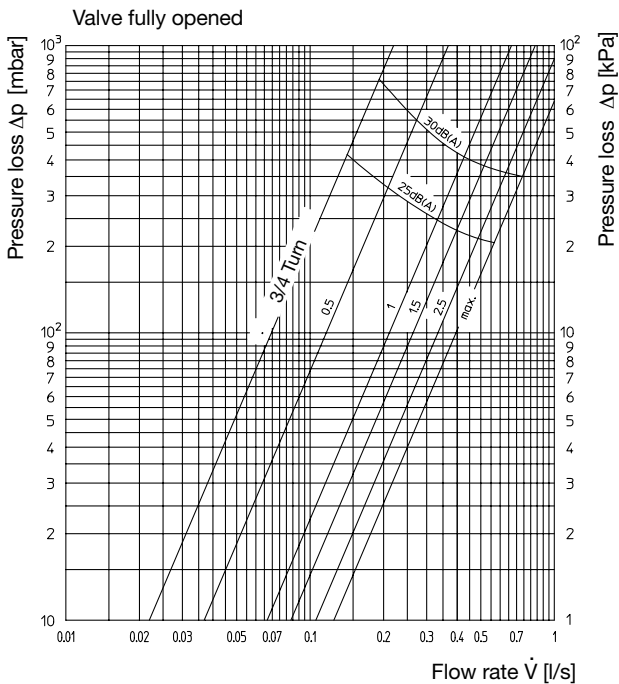
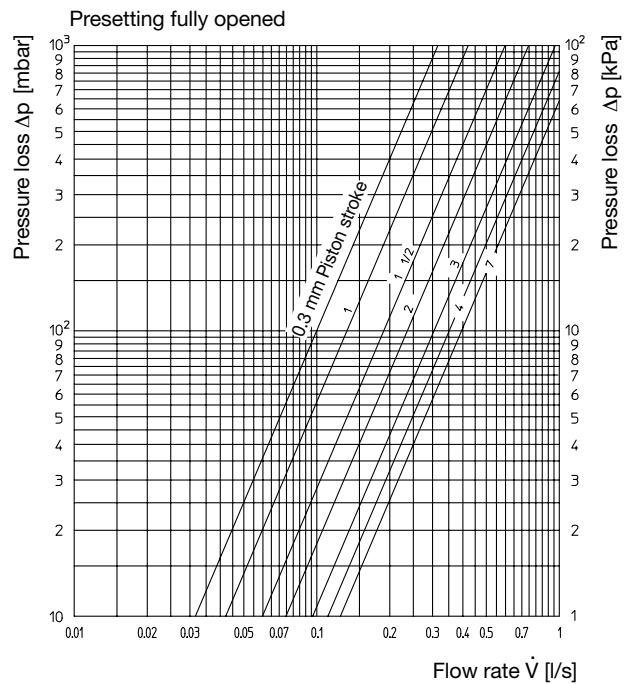
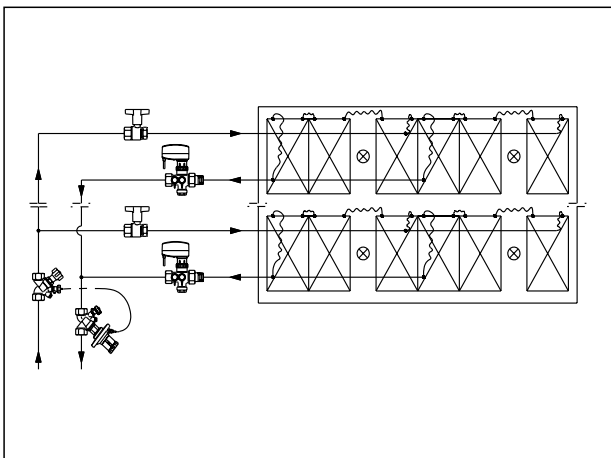


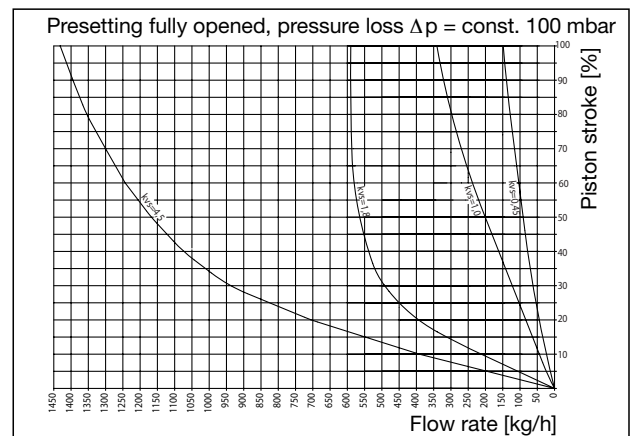
Chart 10



System illustration chilled ceiling installation (example):



Flow rate depending on the piston stroke, linear course of characteristic line for valves with  $k_{VS}$  value 0.45/1.0, chart 11:

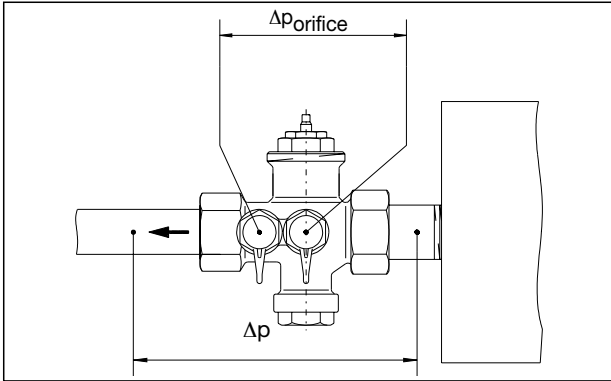


**Control by use of the pressure loss chart**

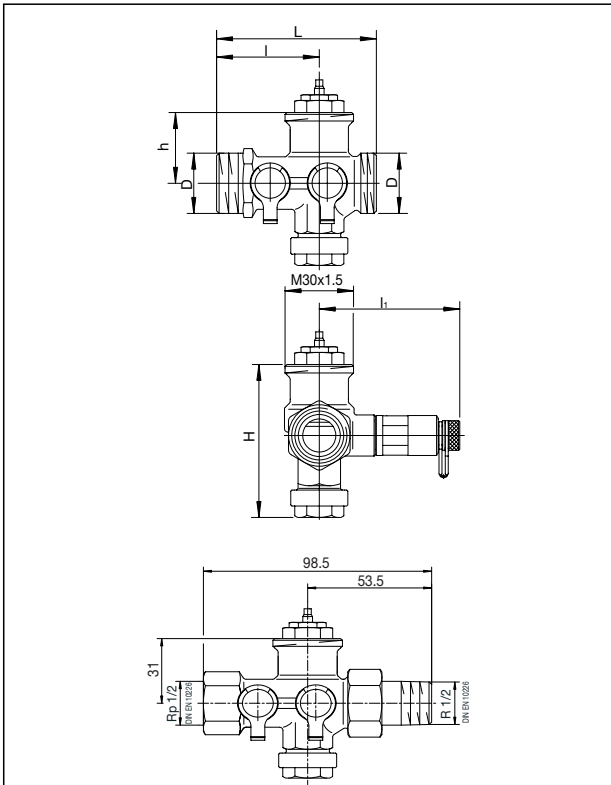
When measuring the differential pressure by use of the “OV-DMC 2” (item no. 106 91 77) or the differential pressure gauge (item no. 106 91 52), the valve must be completely opened as the valve seat acts as measuring orifice. The measured pressure loss  $\Delta p_{\text{orifice}}$  is entered into chart 12 and where this intersects the characteristic line of the corresponding valve insert, determines the actual flow rate. After that, the actual flow rate can be read off.

The flow rate can also be read off the “OV-DMC 2” directly. The characteristic lines are stored in the flow meter.

**Illustr. 5:**



**Dimensions:**

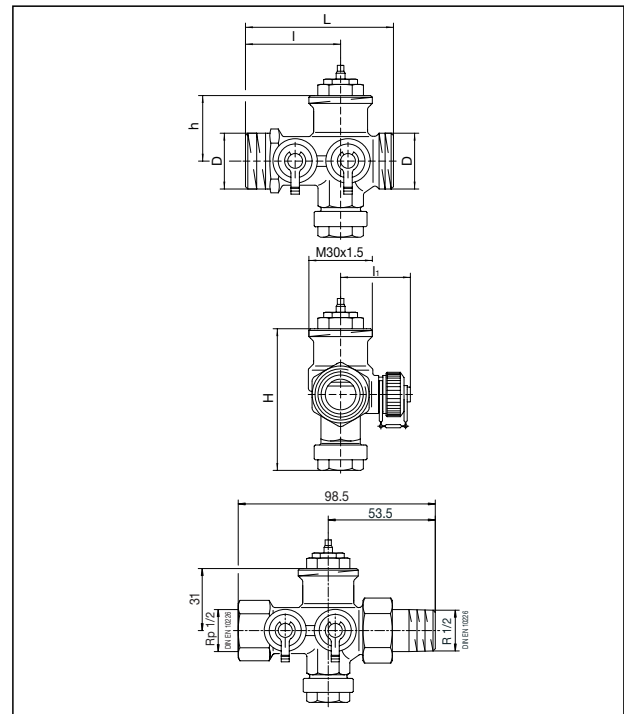
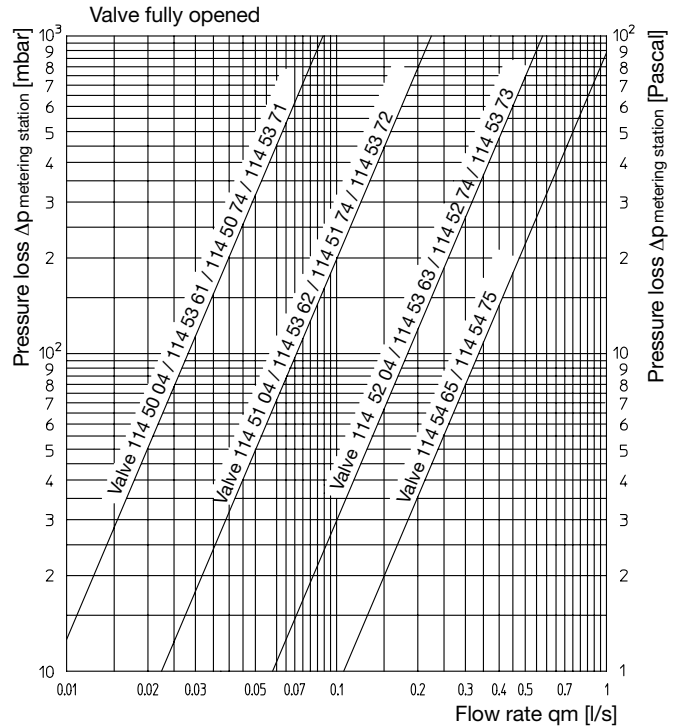


Item no.	D	L	l	l <sub>1</sub>	H	h
114 53 71	3/4"	70	45	61.5	67	31
114 53 72	3/4"	70	45	61.5	67	31
114 53 73	3/4"	70	45	61.5	70	31
114 53 75	1"	80	42	65.5	91	45

Measuring technique “classic”

**Flow rate depending on the pressure loss ( $\Delta p$  metering station) via the pressure test points (see illustr. 5):**

**Chart 12:**



Item no.	D	L	l	l <sub>1</sub>	H	h
114 53 61	3/4"	70	45	33	67	31
114 53 62	3/4"	70	45	33	67	31
114 53 63	3/4"	70	45	33	70	31
114 53 65	1"	80	42	37	91	45

Measuring technique “eco”

F. W. OVENTROP GmbH & Co. KG  
Paul-Oventrop-Straße 1  
D-59939 Olsberg, Germany  
Telephone +49(0) 2962 82-0  
Telefax +49(0) 2962 82-450  
E-Mail mail@oventrop.de  
Internet www.oventrop.de

Subject to technical modification without notice.

Product group 3  
ti 114-1/10/MW  
Edition 2009

Printed on paper free from  
chlorine bleaching.

For an overview of our global  
presence visit [www.oventrop.de](http://www.oventrop.de).