



Description:

The Oventrop “Hydroset MTR” PN 25 is a double regulating valve “Hydrocontrol VTR” with integrated metering station with measuring technique “classic”.

Max. operating temperature t_s : 150°C
 Min. operating temperature t_s : -20°C
 Max. operating pressure p_s : 25 bar (PN 25)

Oventrop “Hydroset” valves are installed in the pipework of hot water and cooling systems and serve to achieve a hydronic balance between the various circuits of the system.

The hydronic balance of the riser is achieved by adjusting the double regulating and commissioning valve during pressure loss measurement at the metering station.

Hydronic balance can also be achieved by use of the presetting with memory position at the valves.

All intermediate values are infinitely adjustable. The selected pre-setting can be read off two scales (basic scale and fine adjustment scale, see illustration presetting).

The “Hydroset MTR” may be installed in either the supply or the return pipe.

The metering station of the “Hydroset” PN 25 is equipped with two pressure test points. Copper pipes (according to EN 1057) can be connected to the DN 15 and DN 20 female thread by use of the suitable “Ofix” compression fittings (reinforcing sleeves are to be used!).

When installing the valve, it must be ensured that the direction of flow conforms to the direction of the arrow on the valve body and that the valve is installed with a minimum of 5 D (5 x nominal pipe diameter) of straight pipe at the valve inlet and of 2 D (2 x nominal pipe diameter) of straight pipe at the valve outlet.

The flow charts are valid for both, installation in the supply or the return pipe, provided the direction of flow conforms to the arrow embossed on the valve body.

In cooling systems using mixtures of water and glycol, the correction factors related to the indicated chart values have to be taken into consideration.



Advantages:

- easy operation by use of only one characteristic line of the metering station
- only one valve for 3 functions:
 - presetting
 - measuring
 - isolating
- the supply and the return pipe can be marked by use of the colour rings supplied with each valve
- low pressure loss (oblique pattern)
- infinitely adjustable presetting, exact control of the flow rate via the metering station
- threads according to EN 10226, suitable for Oventrop compression fittings (102 71 51-58) for copper pipes up to a max. diameter of 22 mm and Oventrop composition pipe “Copipe”
- the flow characteristic lines are stored in the flow-meter “OV-DMC 2” (item no. 106 91 77)

“Hydroset MTR” PN 25
Double regulating and commissioning valve
“Hydrocontrol VTR”
with metering station with measuring technique “classic”
and female threads

Tender specification:

“Hydroset” valves (water pH value 6.5-10) with female threads according to EN 10226, not suitable for steam. Colour rings for marking of supply and return pipe. Oblique pattern with secured, infinitely adjustable fine presetting controllable at any time; optical display of the presetting depending on the position of the hand-wheel; valve body and bonnet made of bronze (Rg 5), disc and stem made of brass resistant to dezincification (DZR), disc with PTFE seal, maintenance-free stem seal due to double O-ring, all functioning components on one level, installation in the supply or the return pipe.

Both ports female thread according to EN 10226 with mounted metering station made of brass resistant to dezincification (DZR) with measuring technique “classic”.

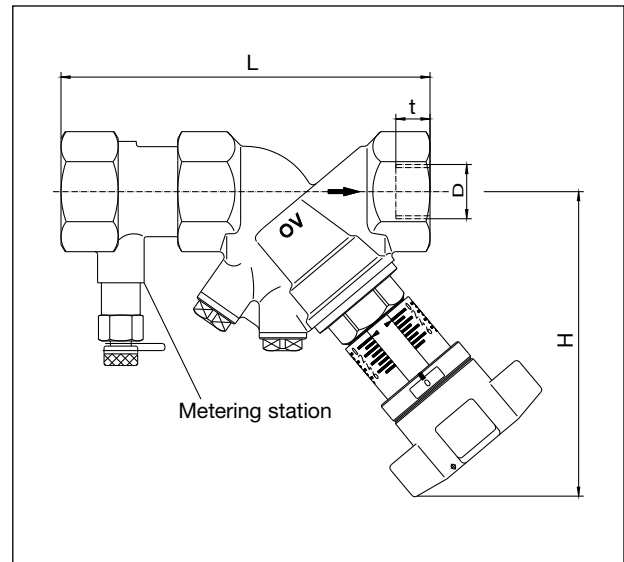

DN	D EN 10226	t	L	H	k _v value of the integrated metering station	Item no.
15 LF	Rp 1/2	13.2	123	114	0.55	106 09 64
15 MF	Rp 1/2	13.2	123	114	1.20	106 09 34
15	Rp 1/2	13.2	123	114	2.20	106 08 04
20	Rp 3/4	14.5	127	116	4.25	106 08 06
25	Rp 1	16.8	145	119	8.60	106 08 08
32	Rp 1 1/4	19.1	164	136	15.90	106 08 10
40	Rp 1 1/2	19.1	172	138	23.70	106 08 12
50	Rp 2	25.7	209	148	48.00	106 08 16

Presetting

- The presetting value of the valve is set by turning the hand-wheel.
 - The display of the basic setting is shown by the longitudinal scale together with the sliding indicator. Each turn of the handwheel is represented by a line on the longitudinal scale.
 - The display of the fine setting is shown by the peripheral scale on the handwheel together with the marking. The subdivisions of the peripheral scale correspond to 1/10th of a turn of the handwheel.
- Limitation of the set value of presetting by turning the inner adjustment stem clockwise up to the limit stop. This can be done by using the long end of a 3 mm Allen key.

Marking of the supply and return pipe:

Clip one of the colour rings (red = supply, blue = return) supplied with each valve onto the handwheel.

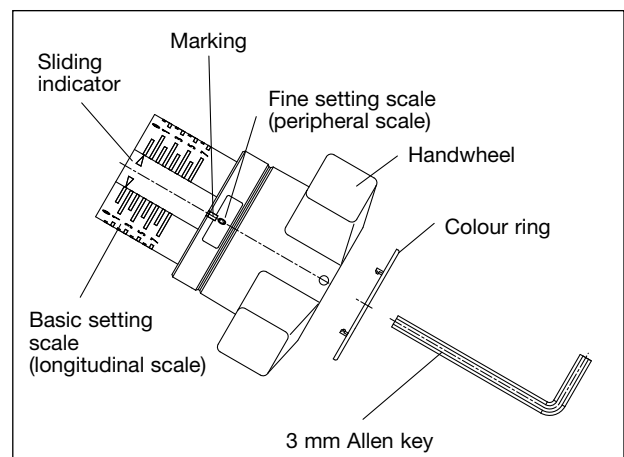

Installation advice:

The Oventrop “Hydroset” valves serve to achieve a hydronic balance between the various circuits of the system. It is to be observed that the direction of flow conforms to the direction of the arrow on the valve body.

Correction factors for mixtures of water and glycol:

When antifreeze liquids are added to the heating water, the pressure loss obtained from the chart must be multiplied by the correction factor f.

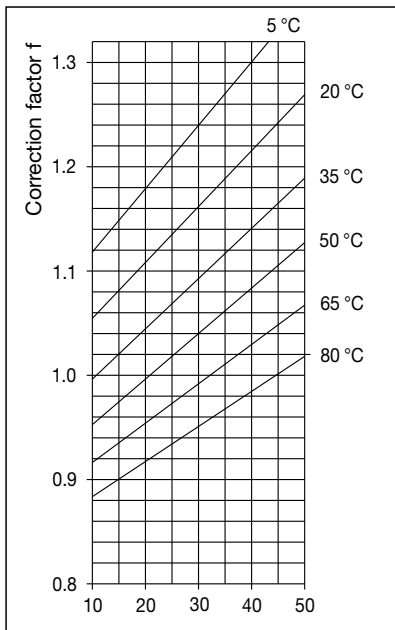

Weight proportion of ethylene glycol [%]

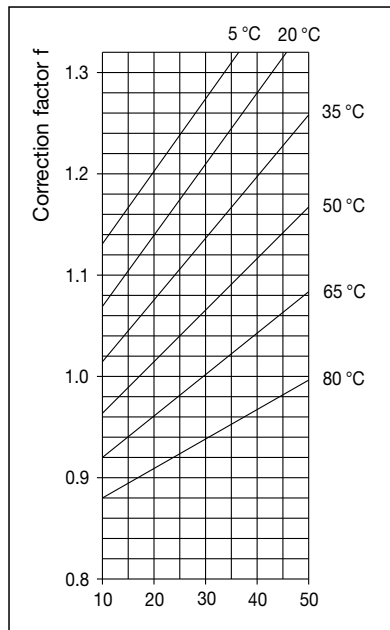

Weight proportion of propylene glycol [%]

Flow chart – Metering station:

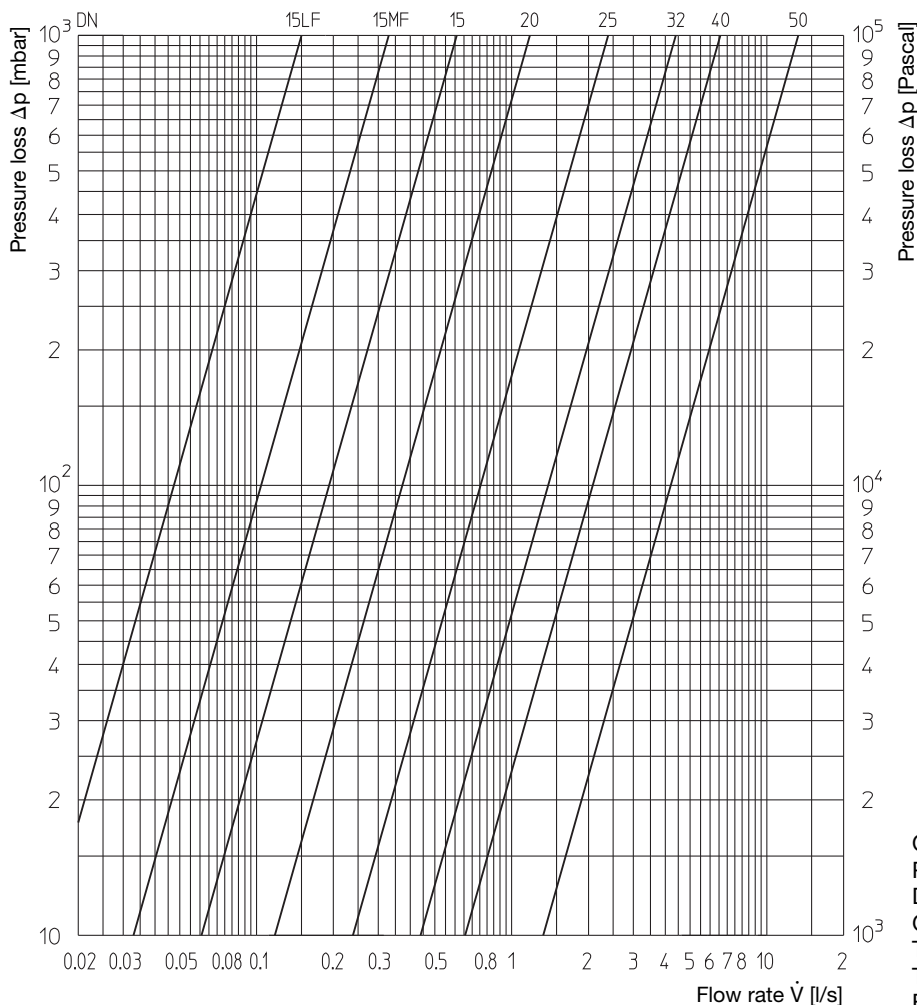

Subject to technical modification without notice.

Product range 1
ti 202-1/10/MW
Edition 2010

Printed on paper free from
chlorine bleaching.

OVENTROP GmbH & Co. KG
Paul-Oventrop-Straße 1
D-59939 Olsberg
Germany
Telephone +49(0)2962 82-0
Telefax +49(0)2962 82-450
E-Mail mail@oventrop.de
Internet www.oventrop.de

For an overview of our global presence
visit www.oventrop.de.