



The Oventrop Quality Management System is certified to DIN-EN-ISO 9001

“Hydrocontrol MTR”

Double regulating and commissioning valve with integrated metering station

Technical information

Function:

The Oventrop “Hydrocontrol MTR” is a double regulating and commissioning valve with integrated metering station and pressure test points with measuring technique “classic”.

Oventrop double regulating and commissioning valves are installed in the pipework of hot water central heating systems and cooling systems and serve to achieve a hydronic balance between the various circuits of the system.

The hydronic balance is achieved by adjusting the double regulating and commissioning valve during flow measurement at the metering station.

Hydronic balance can also be achieved by use of the presetting with memory position at the valves.

The “Hydrocontrol MTR” may be installed in either the supply or the return pipe.

When installing the valve, it must be ensured that the direction of flow conforms to the direction of the arrow on the valve body and that the valve is installed with a minimum of 3 D (3 x nominal pipe diameter) of straight pipe at the valve inlet and of 2 D (2 x nominal pipe diameter) of straight pipe at the valve outlet.

In cooling systems using mixtures of water and glycol, the correction factors have to be taken into consideration.

Advantages:

- the location of the functioning components on one level allows a simple assembly and easy operation
- a constant kv value of the metering station for all presetting values allows an easy and quick regulation
- only one valve for 3 functions:
 - presetting
 - measuring
 - isolating
- the supply and return pipe can be marked by use of the colour rings supplied with each valve
- low pressure loss (oblique pattern)
- infinitely adjustable presetting, exact control of the flow rate via the metering station
- connection threads according to EN 10226, suitable for Oventrop compression fittings (102 71 51-58) for copper pipes up to a max. diameter of 22 mm and Oventrop composition pipe “Copipe”
- exact measurement of the pressure loss which is proportional to the flow rate via the integrated metering station
- optical display of the kv value of the integrated metering station on the affixed identification plate

Tender specification:

Double regulating and commissioning valve PN 25 (water pH value 6.5-10) with female threads according to EN 10226 and integrated metering station, not suitable for steam. Colour rings for marking of supply and return pipe. Oblique pattern with secured, infinitely adjustable fine presetting controllable at any time; optical display of the presetting depending on the position of the handwheel; valve body and bonnet made of bronze (Rg 5), disc, stem and metering station made of brass resistant to dezincification (DZR), disc with PTFE seal, maintenance-free stem seal due to double O-ring, all functioning components on one level, installation in the supply or the return pipe.

Max. operating temperature t_s : 150°C
 Min. operating temperature t_s : -20°C
 Max. operating pressure p_s : 25 bar (PN 25)



DN	D EN 10226	Item no.	k_{vs}	k_v value of the integrated metering station
15	Rp 1/2	106 04 04	2.1	2.2
20	Rp 3/4	106 04 06	3.7	4.25
25	Rp 1	106 04 08	6.1	8.6
32	Rp 1 1/4	106 04 10	12.5	15.9

Dimensions:

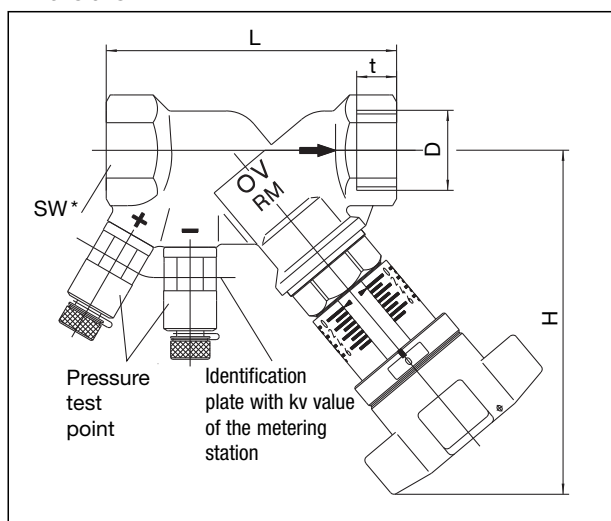

DN	D EN 10226	t	L	H	SW*
15	Rp 1/2	13.2	87	114	27
20	Rp 3/4	14.5	96	116	32
25	Rp 1	16.8	102	119	41
32	Rp 1 1/4	19.1	119	136	50

* SW = spanner size

Accessories sets:

1 pressure test point extension (80 mm)	106 02 95
1 pressure test point extension (40 mm)	168 82 95
1 stem extension (35 mm)	168 82 96
Lead sealing set (10-fold)	108 90 91
Locking set (1-fold)	106 01 80

Presetting:

1. The presetting value of the valve is set by turning the handwheel.
 - a. The display of the basic setting is shown by the longitudinal scale together with the sliding indicator. Each turn of the handwheel is represented by a line on the longitudinal scale.
 - b. The display of the fine setting is shown by the peripheral scale on the handwheel together with the marking. The subdivisions of the peripheral scale correspond to 1/10th of a turn of the handwheel.
2. Limitation of the set value of presetting by turning the inner adjustment stem clockwise up to the limit stop. This can be done by using the long end of a 3 mm Allen key.

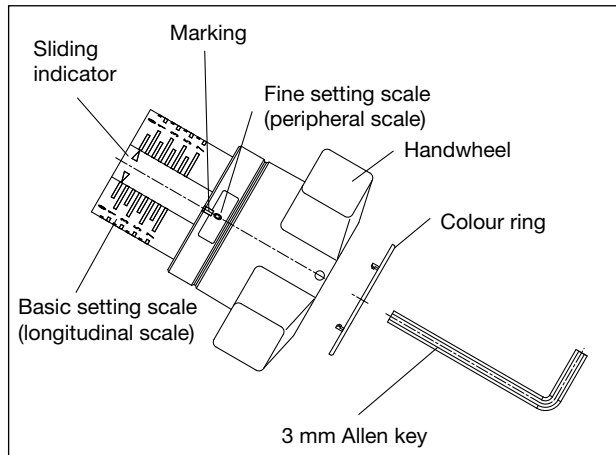

Flow chart – Metering station

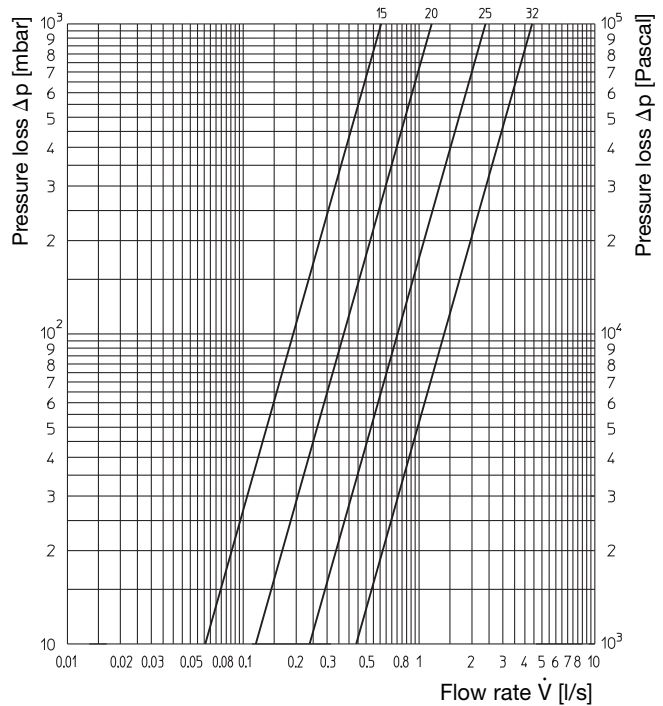

Correction factors for mixtures of water and glycol:

When antifreeze liquids are added to the heating water, the pressure loss obtained from the chart must be multiplied by the correction factor f.

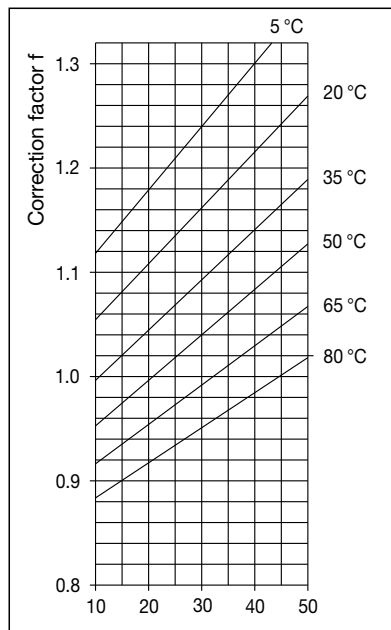

Weight proportion of ethylene glycol [%]

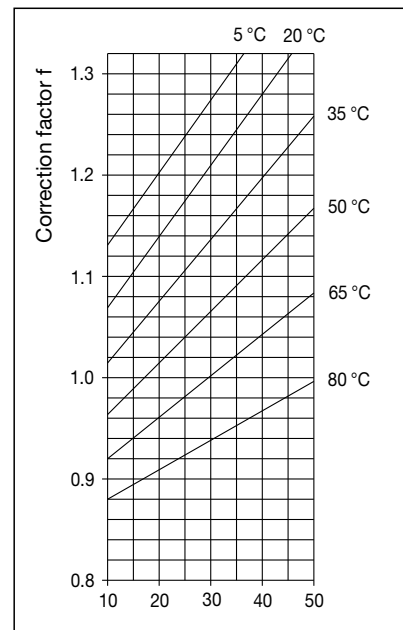

Weight proportion of propylene glycol [%]

OVENTROP GmbH & Co. KG
 Paul-Oventrop-Straße 1
 D-59939 Olsberg
 Germany
 Telephone +49(0) 2962 82-0
 Telefax +49(0) 2962 82-450
 E-Mail mail@oventrop.de
 Internet www.oventrop.de

Subject to technical modification without notice.

Product range 5
 ti 224-1/10/MW
 Edition 2010

Printed on paper free from chlorine bleaching.

For an overview of our global presence visit www.oventrop.de.