

# HANDBOOK

## Series NO fully automatic oil burners Models NOL/NOR Modulating

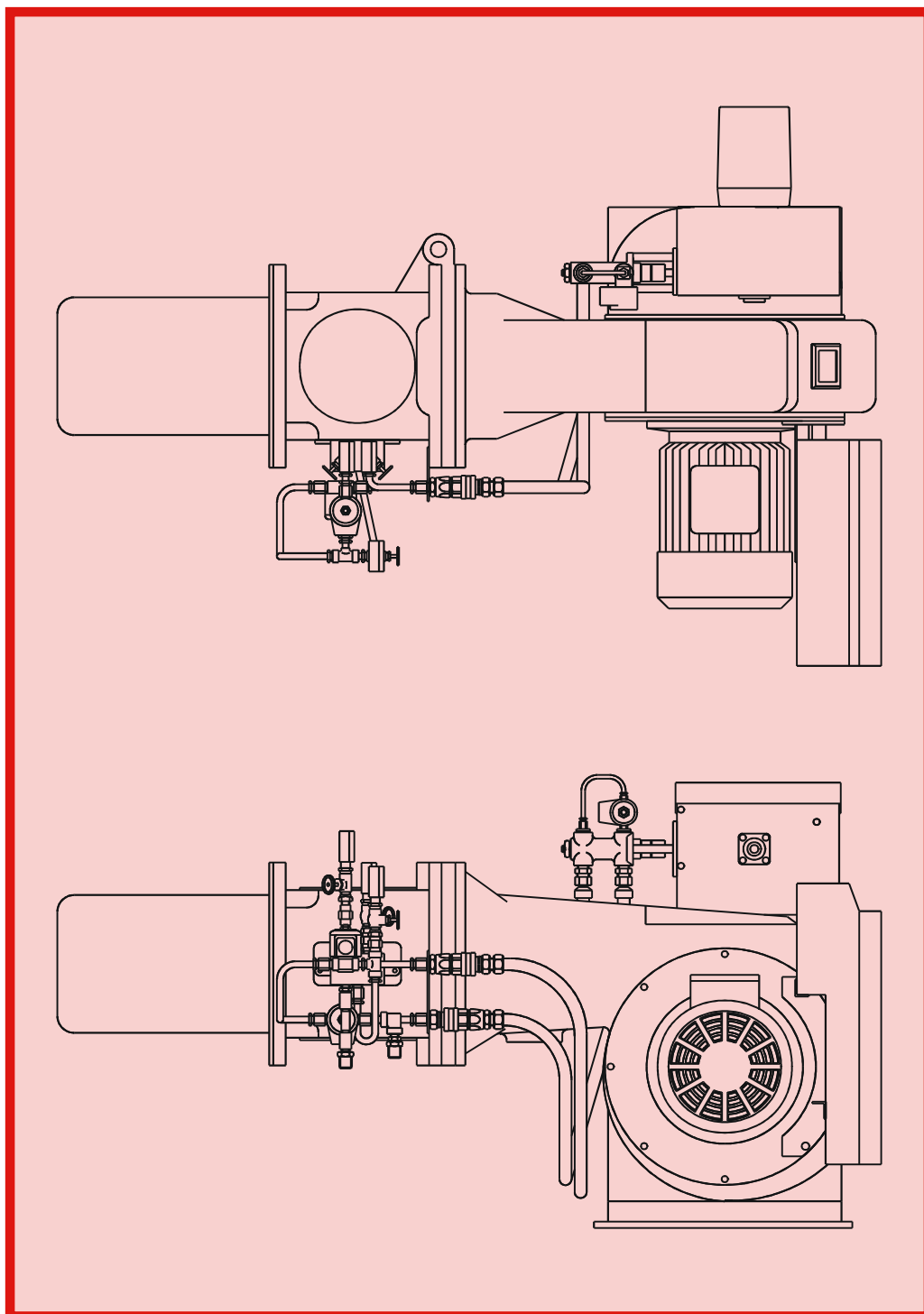

Distillate & Residual Fuel Oils

# CONTENTS

<b>BURNER &amp; COMPONENT IDENTIFICATION FOR NO35-34 To NO100-38 MODULATING BURNERS</b>	<b>4</b>
<b>BURNER &amp; COMPONENT IDENTIFICATION FOR NO100-41 To NO150-44 MODULATING BURNERS</b>	<b>6</b>
<b>INTRODUCTION</b>	<b>8</b>
<b>FEATURES</b>	<b>8</b>
Burner Nominal Capacities	8
Controls and Safety Systems	8
Operating Mode	8
Fuels	8
<b>SITE CONDITIONS AND SERVICES</b>	<b>8</b>
Flue and Chimney Requirements	8
Plant Room Ventilation	8
Existing Appliances	8
Combustion Chamber Conditions	8
Oil System	9
Main Oil Storage Tank	9
Oil Supply to the Burner	9
Single Pipe System	9
Pumped Ring Main System	9
Burner Pump Capacities	9
Filtration	9
Electrical Power Supply	9
<b>UNPACKING AND ASSEMBLY</b>	<b>9</b>
<b>TYPICAL RINGMAIN OIL SYSTEM</b>	<b>10</b>
<b>BURNER OIL SYSTEM</b>	<b>11</b>
<b>INSTALLATION</b>	<b>12</b>
General	12
Fitting To the Appliance	12
Connections	12
Electrical Power Connection	12
<b>BURNER CONTROL AND OPERATION</b>	<b>12</b>
Burner Description	12
<b>ELECTRICAL CONNECTION DIAGRAM</b>	<b>13</b>
<b>BURNER CONTROLS</b>	<b>14</b>
Oil Pumping / Pumping & Heating Units	14
Modulating Unit	14
Residual Oil Heating Controls	14
Safety Features	14
<b>OIL PUMPING / PUMPING &amp; HEATING SET</b>	<b>15</b>
<b>COMMISSIONING</b>	<b>16</b>
<b>IMPORTANT - SAFETY EMERGENCY INSTRUCTIONS</b>	<b>16</b>
Inspection	16
Pre-firing Checks	16

Hand Auto Selector Switch	17
Commissioning the Burner	17
<b>MODULATING UNIT</b>	<b>18</b>
<b>ROUTINE MAINTENANCE OF NOL/NOR MODULATING BURNERS</b>	<b>19</b>
General	19
Daily Checks	20
Cleaning the Oil Nozzle	20
Photoelectric Cell	20
Cold Oil Filter(s)	20
Replenishing the Fuel Supply	20
Boiler Combustion Surface	20
<b>FAULT FINDING</b>	<b>20</b>
If the Burner Fails to Start	20
If the burner is found at lockout (red lockout lamp illuminated)	20
Flame Occurs Followed by Immediate Lockout	21
The Burner Starts With The Correct Oil Pressure But No Flame Appears	21
Modulating System	21
<b>FUEL PUMPS</b>	<b>21</b>
Danfoss Series KSA Fuel Pumps	21
Suntec Series TA Fuel Pumps	21
Suntec Series TV Pressure Regulating Valve	21
Oil Pumps - Where Used	23
<b>FLAME FAILURE &amp; SEQUENCE CONTROLS</b>	<b>23</b>
Burner Control Program	23
<b>MODULATING CONTROL</b>	<b>24</b>
Landis & Staefa RWF32	24
RWF32 Recommended Settings	24
<b>BURNER OIL NOZZLE</b>	<b>26</b>
<b>SERVICE &amp; REPLACEMENT</b>	<b>26</b>
<b>APPENDIX</b>	<b>27</b>
Burner Performance Graph	27
Burner Head Details & Electrode Settings	28
Electrical Data Table	29
Burner Commissioning Sheet	30

## **IMPORTANT - SAFETY**

It is essential that the following instructions and adjustments are carried out by qualified engineers that are experienced in pressure jet oil burner commissioning. The manufacturer cannot be held responsible for any consequential damage, loss or personal injury as a result of customers failing to follow these instructions, or as a result of misuse. Your attention is drawn to the **Emergency Instructions** on page 16

## **EUROPEAN BOILER EFFICIENCY DIRECTIVE (B.E.D.)**

All burners and boiler bodies marketed separately should comply with EN267 (oil burners) or EN676 (gas burners) and EN303-1 (boiler bodies).

Burner adjustments must be made in accordance with boiler manufactures' instructions, and these must include flue gas temperatures, average water temperature, and CO<sub>2</sub> or O<sub>2</sub> concentration.

# BURNER & COMPONENT IDENTIFICATION FOR NO35-34 TO NO100-38 MODULATING BURNERS

Standard Burner Arrangement Shown

All dimensions are mm.

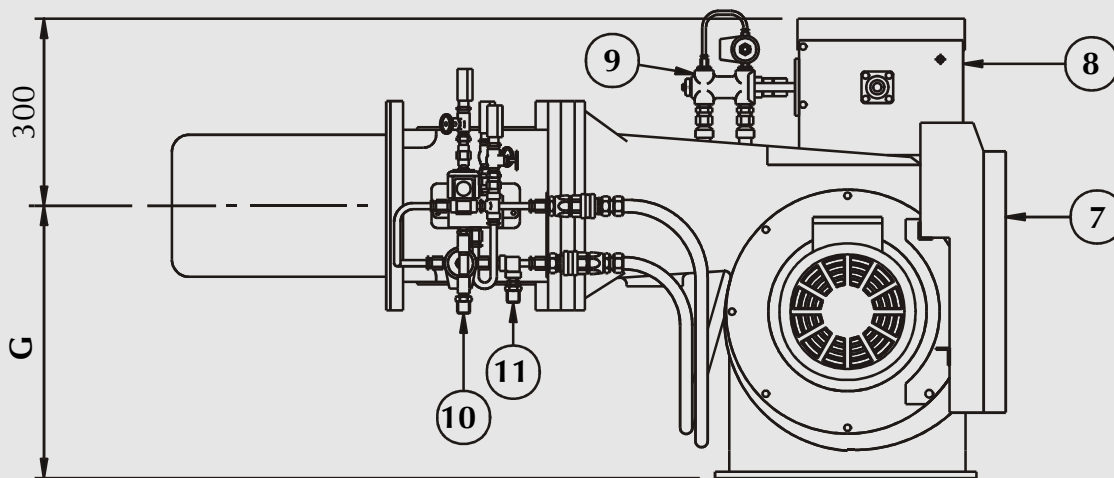
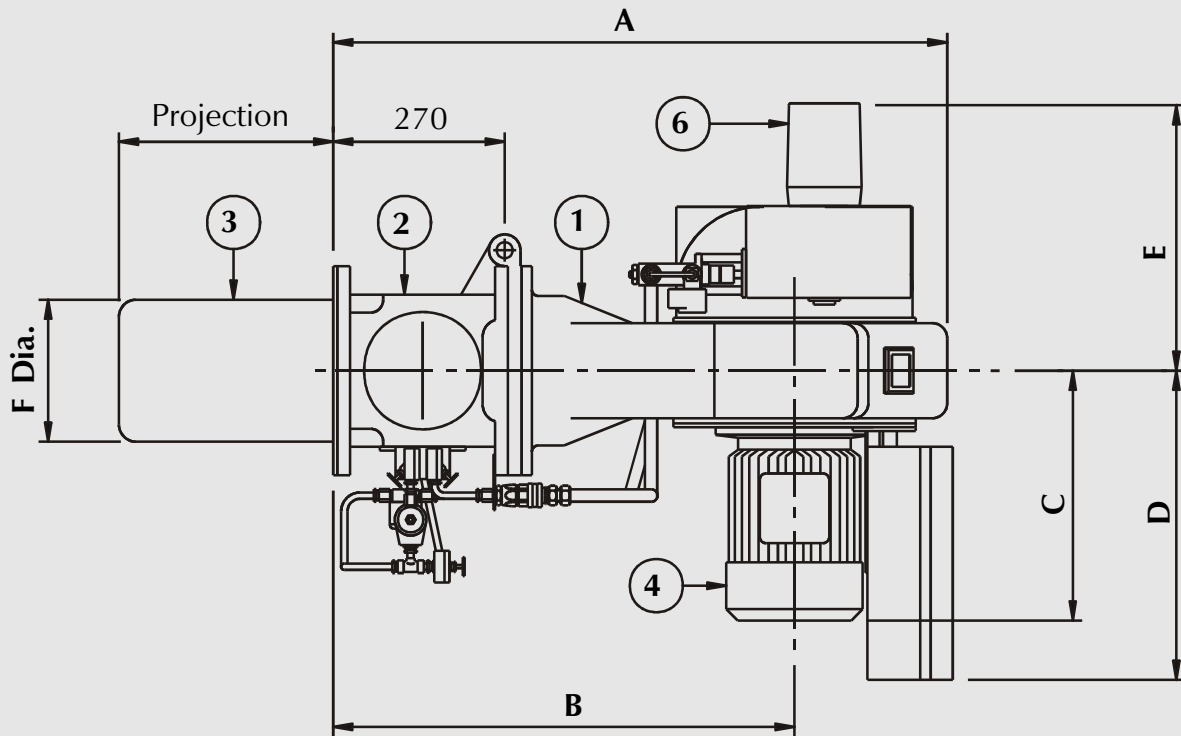

## Burner Mounting Details

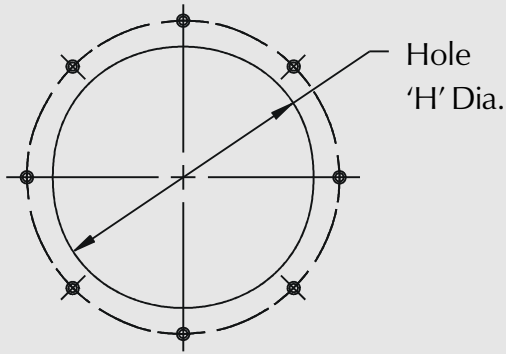

8 Holes M10 Equispaced On  
305mm PCD

Item	Description
1	Burner Casing
2	Hinged Extension
3	Flame Tube
4	Fan Motor
5	Air Inlet
6	Modulating Control Motor
7	Control Panel
8	Modulating Cam Unit
9	Oil Spill Control Valve
10	Oil Inlet Connection
11	Return Oil Connection
12	Fan Inspection Cover

Burner Model	A	B	C	D	E	F	G	H
NO*18-34	967	730	420	457	430	182	387	216
NO*18-38	1014	755	457	480	430	182	480	216
NO*35-34	967	730	420	457	430	223	387	254
NO*35-38	1014	755	457	480	430	223	480	254
NO*50-28	967	730	420	420	430	223	387	254
NO*50-34	967	730	457	457	430	223	387	254
NO*50-38	1014	755	480	480	430	223	480	254
NO*60-28	967	730	457	457	430	223	387	254
NO*60-34	967	730	480	480	430	223	387	254
NO*60-38	1014	755	480	480	430	223	480	254
NO*85-38	1014	755	537	537	430	254	480	280
NO*100-38	1014	755	537	537	430	254	480	280

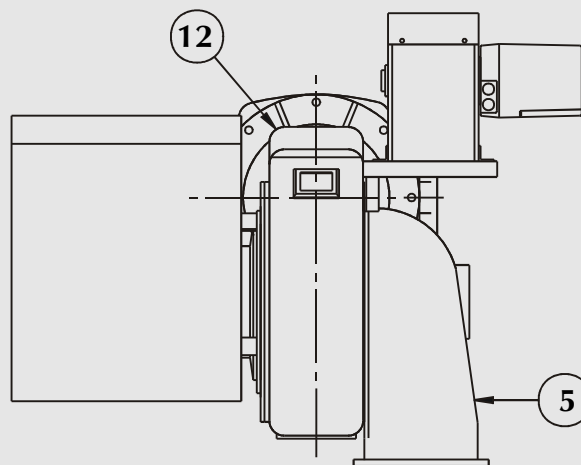

# BURNER & COMPONENT IDENTIFICATION FOR NO100-41 To NO150-44 MODULATING BURNERS

Compact Burner Arrangement Shown  
All dimensions are mm

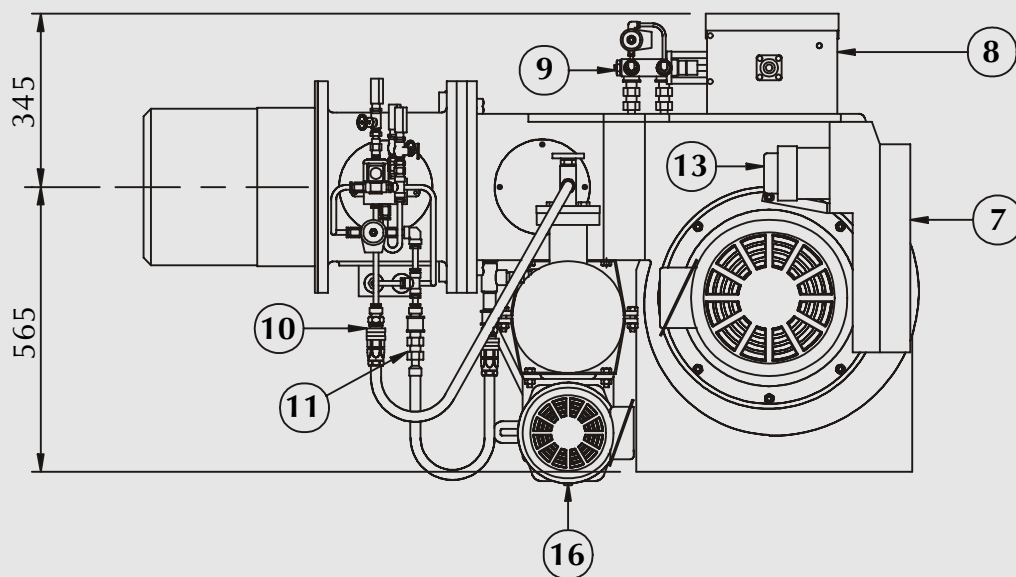
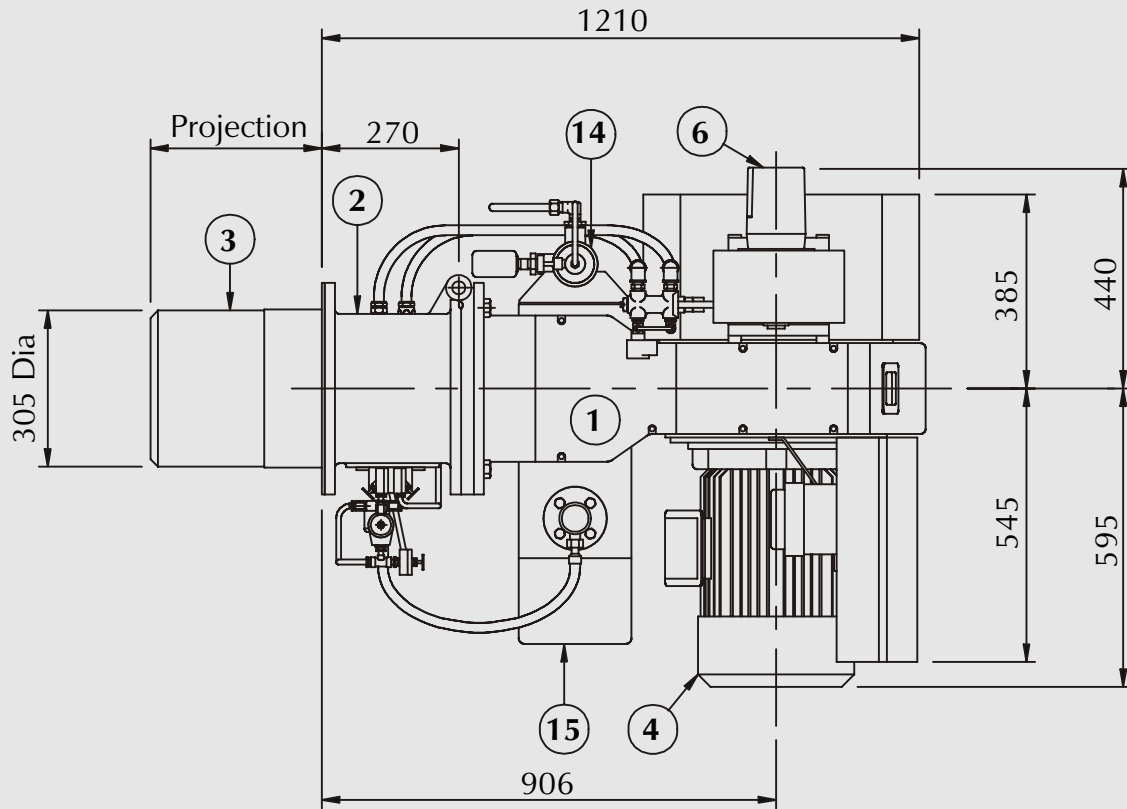

## Burner Mounting Details

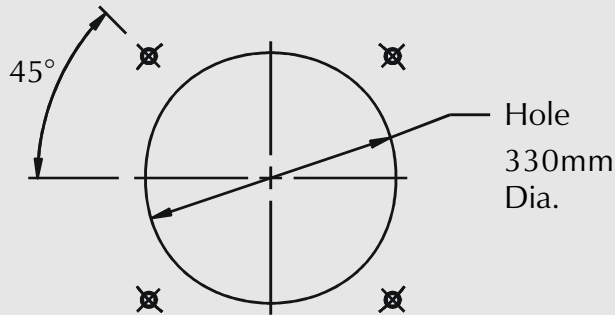

4 Holes M20 Equispaced On  
454mm PCD

Upon request NO Modulating burners can be supplied in the fully assembled 'compact' configuration as shown.

On 'compact' models NO\*18, 35 & 50 the Oil Pump may be driven by the fan motor. All other models utilise an independant pumping set.

Supply oil connections are made to the Air Seperator Bottle item 14. Refer to the Pumping Unit connections shown on page 15 for identification.

Standard burners are supplied with a floor mounted pumping or pumping & heating unit. In this configuration, the system oil connections 10 & 11 on pages 4 & 5 refer.

Item	Description
1	Burner Casing
2	Hinged Extension
3	Flame Tube
4	Fan Motor
5	Air Inlet
6	Modulating Control Motor
7	Control Panel
8	Modulating Cam Unit
9	Oil Spill Control Valve
10	Burner Head Oil Inlet Quick Release Connection
11	Burner Head Return Oil Quick Release Connection
12	Fan Inspection Cover
13	Ignition Transformer

Items 14 to 16 Refer to  
Compact Modulating Burners  
Only

Item	Description
14	Air Seperator Bottle
15	Oil Preheater Unit
16	Oil Pumping Unit

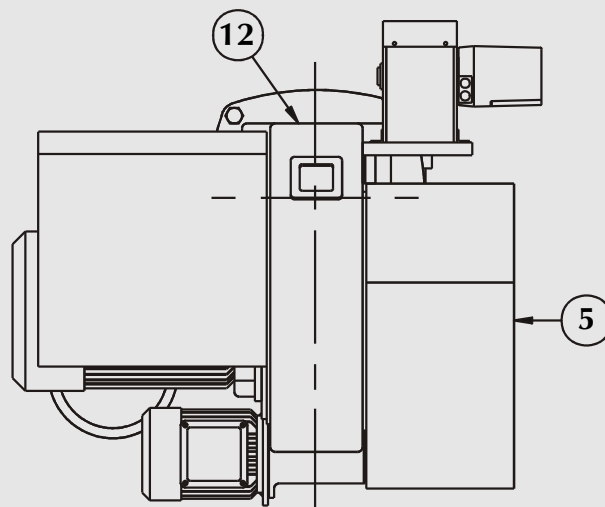

## INTRODUCTION

This manual has been produced to enable users to install, commission and use NO Modulating burners safely and efficiently. The manual covers two types of burner: Models NOL distillate (Class D fuel) oil burners and models NOR residual (Class E, F & G) oil burners. At each stage the conditions which should be met and the adjustments and other actions which should be carried out are detailed and the locations of the various components and adjustment mechanisms are identified. Where appropriate, this information is supported by tables and graphs. Literature on the proprietary components used in NO Modulating systems is available on request.

## FEATURES

Developed through extensive field experience in the UK and overseas markets, the NO Fully modulating series meets the current known test authority requirements in these markets and sets new standards in efficient and reliable operation. NO Modulating burners are designed for flange mounting to the appliance front plate and they are delivered ready to install with a pre-wired packaged control system and oil pumping or pumping & heating unit.

### Burner Nominal Capacities

NO18 (2 Models)	530 kW	42.0 kg/h
NO35 (2 Models)	940 kW	74.0 kg/h
NO50 (3 Models)	1750 kW	138.0 kg/h
NO60 (3 Models)	2100 kW	165.5 kg/h
NO85 (1 Model)	2432 kW	192.0 kg/h
NO100 (2 Models)	2930 kW	231.5 kg/h
NO125 (3 Models)	3668 kW	290.0 kg/h
NO150 (3 Models)	4396 kW	347.0 kg/h

### Controls and Safety Systems

NO Modulating burners are fitted with an automatic sequence / flame failure control and photo-electric cell for continuous flame supervision. A combustion air flow control coupled to an oil nozzle pressure control system ensures smooth starting and optimum operating efficiency.

### Operating Mode

In standard form the NO Fully Modulating burner can provide a turndown range of up to 3:1.

## Fuels

NO burners covered in this manual are designed to fire distillate and residual fuel oils, which comply with the specifications given in the tables on page 10. NO burners configured for firing other fuel grades may be available on request.

## SITE CONDITIONS AND SERVICES

### Flue and Chimney Requirements

It is important that:

- The flue pipe from the appliance and the joint between this flue and the chimney are sealed to prevent leakage of combustion products.
- The flue pipe from the appliance does not protrude into the chimney beyond the inside wall.
- The top of the flue or chimney shall be higher than any roof within a radius of 10 metres.
- Checks are made to ensure that the chimney is suitable for oil fired appliances and that the proposed installation complies with all Local Authority and other regulations covering such installations.
- If more than one appliance is connected to a common flue or chimney the cross-section of this flue or chimney should be adequate for the total volume of combustion products from the appliances. It is recommended that each appliance should be exhausted into a separate flue.

### Plant Room Ventilation

The burner must be supplied with dust free air at sufficient rates for all firing conditions, in accordance with the appropriate standards.

### Existing Appliances

The appliance should be prepared for installation of the NO burner by thorough cleaning, including the removal of all adhering tar, scale and dirt. An inspection should also be carried out to ensure that the appliance is in good condition. Any doubt about the appliances suitability for oil firing shall be referred to the appliance manufacturer.

### Combustion Chamber Conditions

The combustion chamber conditions should not exceed those shown on page 27 of this manual.



Burners working with zero rated combustion chamber conditions can be subjected to a maximum negative chamber condition of 0.05 kPa (0.5 mb)

### Oil System

Refer to the drawings on page 11 for details of the burner oil system.

### Main Oil Storage Tank

Residual oils must be maintained at all times to a temperature specified by the supplier.

### Oil Supply to the Burner

The oil supply from the storage tank to the burner may be provided by:

- (a) Single pipe gravity feed system. Class D only.
- (b) Pumped ring main system. Class E, F and G fuels.

### Single Pipe System

The height of the main storage tank above the burner and the sizing of the pipe to the burner must be designed so that the oil pressure at the burner oil pump inlet is not less than 35 kPa (0.35 bar). The maximum oil pressure at the burner pump inlet must not exceed 500 kPa (5.0 bars) under any operating conditions.

The pipe must be sized to the full swept volume of the burner oil pump and not the capacity of the burner nozzles.

### Pumped Ring Main System

The pumped ring main is the preferred system of oil supply and is essential for multiple burner installations and where heavy residual fuel oils are to be used.

The ring main pumps and supply pipe work must be designed to cater for 1.25 times the total swept volume of the burner oil pumps connected to the supply system.

All oil supply pipes must be constructed and installed to comply with local conditions and appropriate codes of practice and standards. All pipe work must be firmly supported and in the case of residual fuel oils, lagged, traced and thermostatically controlled. A Pressure Reducing Valve (PRV) should be fitted to control the supply pressure.

Further details are shown in the typical ring main diagram on page 10

### Burner Pump Capacities

The oil pumps used on Nu-Way modulating oil burners are listed in the table on page 23. It is essential that the full swept volume of the pump be considered when oil supply lines or ring main systems are calculated.

The minimum recommended size of the supply pipe or ring main is 2" BSP when residual oil is used.

Lagging and tracing is considered essential for residual fuel. The table on page 10 gives the recommended storage and oil supply temperature required at the burner pump.

### Filtration

When using fuel oils and in particular residual grades, filtration of the oil is essential. The filtration system should be chosen according to the individual features of the installation. The ring main system diagram on page 10 gives guidelines. When the ring main pressure is checked then this should be measured at the burner pump vacuum gauge port to allow for any pressure drop across the filters.

Failure to provide a good clean oil supply will almost certainly lead to premature wear and rapid failure of the oil pump unit.

### Electrical Power Supply

A three phase 50 Hz supply is required (60 Hz burners are available on request). Power requirements are tabulated in the *Appendix* of this handbook. The power supply provided must comply with all relevant Codes and Standards.

## **UNPACKING AND ASSEMBLY**

To safeguard against damage in transit, NO Modulating burners may be supplied in partly assembled form in one of three alternative modes:

### Mode 1:

The complete burner unit fully assembled.

### Mode 2:

Burner body complete with control panel. Combustion head hinged extension and flame tube assembly

To assemble the burner:

Assembly of the burner can be completed after fitting the hinged extension/flame tube assembly to the appliance.

Alternatively, fit the extension/flame tube assembly to the burner body using the eight nuts and washers provided.

A pumping and heating unit, or pumping unit in the case of distillate burners is supplied as a separate component to modes 1 and 2 and is inclusive of flexible pipes to make all the necessary oil connections.

### Mode 3:

Upon request NO Modulating burners can be supplied in a fully assembled compact configuration. These burners include the oil pumping and conditioning unit mounted beneath the burner body and are pre-piped, requiring only the connection of fuel and electrical supplies to complete the installation. The suitability for installation of compact modulating burners should be referred to the appliance manufacturer as the addition of the oil pumping or pumping & heating unit adds extra weight to the appliance frontplate.

## TYPICAL RINGMAIN OIL SYSTEM

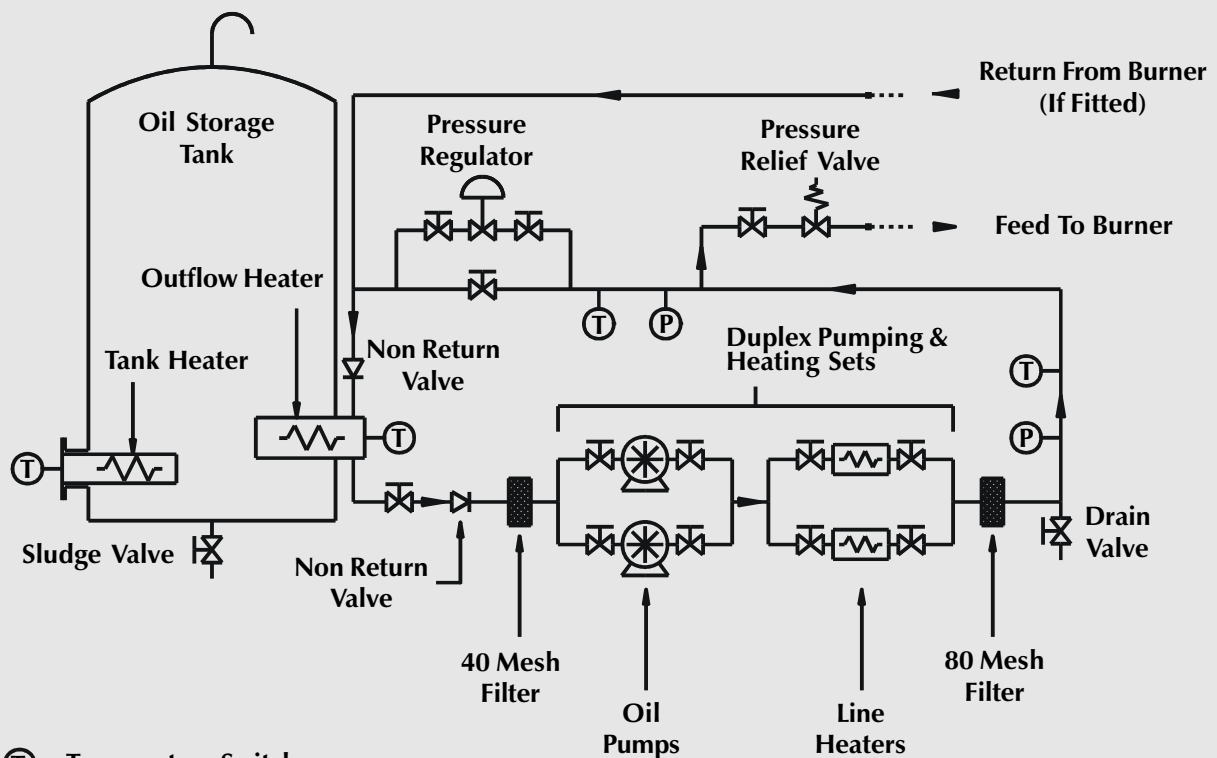

- Ⓣ Temperature Switch
- Ⓟ Pressure Switch
- ⊠ Manual Shut Off Valve

### Fuel Handling Temperatures

Fuel Class	Secs	Minimum From Tank	Inlet to Burner	Atomising Temperature
D	35	-	-	-
E	200	16°C	16°C	82°C
F	960	30°C	43°C	110°C
	1500	36°C	65°C	118°C
G	3500	50°C	82°C	132°C
	4200	55°C	86°C	140°C

The fitting of duplex Oil Pumping & Heating sets is recommended for system continuity and serviceability.

Line heaters are recommended for Class F & G fuels. They are generally not necessary for Class E fuel.

Pre-heating of Class D fuel is not required, however fuel companies recommend a minimum fuel temp of 5°C and that all exposed pipework should be lagged.

# BURNER OIL SYSTEM

## Pumped Systems - All Burners

All inter-connecting pipework to be minimum 19mm bore and pressure rated for 42kg/cm<sup>2</sup> (600 psi).

On Residual fuel burners this pipework must be maintained at the burner atomising temperature and In the case of Class 'F' and 'G' fuels, must also be traced.



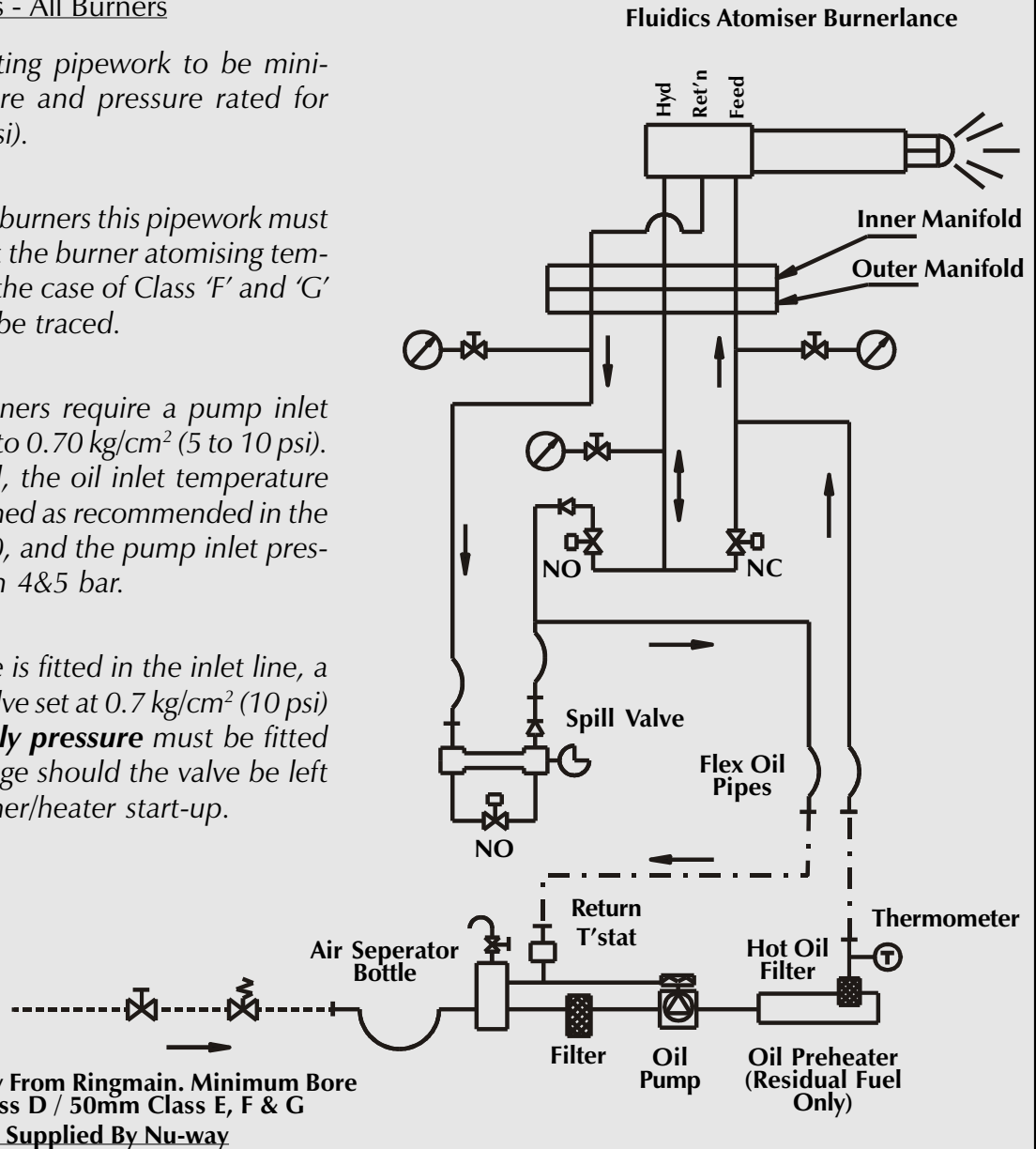

Distillate oil burners require a pump inlet pressure of 0.35 to 0.70 kg/cm<sup>2</sup> (5 to 10 psi). For Residual fuel, the oil inlet temperature must be maintained as recommended in the table on page 10, and the pump inlet pressure set between 4&5 bar.

If a shut off valve is fitted in the inlet line, a pressure relief valve set at 0.7 kg/cm<sup>2</sup> (10 psi) above the supply pressure must be fitted to prevent damage should the valve be left shut during burner/heater start-up.



Pumped Supply From Ringmain. Minimum Bore 25mm Class D / 50mm Class E, F & G  
Not Supplied By Nu-way

Pipework Shown In Chain Dot Not Supplied By Nu-way. (Not Required On Compact Burner Arrangement)

-  Oil Pressure Gauge
-  Manual Shut Off Valve
-  Oil Solenoid Valve  
NO/NC = Normally Open/Closed
-  Non Return Valve
-  Pressure Relief Valve

### Notes.

The Oil Preheater, Return Oil Thermostat and Spill Valve NO bypass Solenoid Valve are not fitted on Distillate fuel systems.

## INSTALLATION

---

### General

---

Ensure that the appliance is suitable for the heat input of the burner. If there is any doubt in this area, reference shall be made to the appliance manufacturer. Detailed burner performance data are presented in the *appendix* of this handbook.

### Fitting To the Appliance

---

If the burner is to be fitted to a new appliance refer to the appliance manufacturers recommendations.

If the burner is to be fitted to an existing appliance a mounting flange must be provided as detailed in the section on *Burner & Components Identification*. Ensure that the joint between the burner and the mounting flange is sealed effectively using the gasket provided.

The flame tube should not extend beyond the inner face of the appliance combustion chamber unless the appliance manufacturer specifies extensions, for example in the case of reverse flame boilers.

### Connections

---

Once the burner is mounted to the appliance, open the hinged extension by removing the two nuts and washers, connect the HT leads to the ignition electrodes and close and fasten the extension.

Connect the flexible oil pipes between the burner and the pumping or pumping and heating unit by referring to the burner component and pumping or pumping & heating unit drawings on pages 4,5&15.

Connect the oil supply to the burner pumping unit with reference to the oil system diagrams and pumping unit drawings on pages 10,11&15.

### Electrical Power Connection

---

Connect a three-phase, 50 Hz electrical supply to the burner, observing all applicable Codes and Standards. The electrical connections required are shown opposite and in the wiring diagram contained in the instruction pack attached to the burner. These diagrams also show the auxiliary control connections, which must be made.

If the burner is supplied as part of a packaged appliance/burner unit refer to the appliance manufacturers instructions.

## BURNER CONTROL AND OPERATION

---

**All personnel concerned with commissioning and/or operation of NO modulating burners shall familiarise themselves with the information presented in this section.**

### Burner Description

---

Nu-way NOL/NOR modulating series fully automatic oil burner units are of packaged design and meet relevant National and International standards based on the ISO system of measurement and fastening.

A system of pressure atomisation employing a single spill back nozzle is used throughout the range. If the burner is equipped with the **Nu-way Electronic Cam Modulation (ECM)** system, then reference should also be made to the supplementary documentation supplied with this handbook. In this case references to the RWF32 Universal Controller and Modulating Unit within this handbook can be ignored.

The standard method of operation is based on the Landis & Staefa RWF32 Universal Controller, which has been designed for use in oil and gas fired installation, where it provides temperature or pressure control of modulating burners with continuously adjustable fuel throughput.

The control output of the RWF32 is a potential free 3-position switch, which is used for the control of reversible motors. The control signals for the open (Y1) and closed (Y2) are indicated on the controller face by light emitting diodes.

Replaceable range insert PCB's which are used in conjunction with passive detectors of type QAE21 (Temperature) and QBE61 (Pressure) achieve configuration of the unit to a control value and setting range. For further information on the RWF32 and its associated components please refer to the data provided on page 25 of this handbook.

When the boiler control calls for heat, the burner modulating unit will travel to the 'high flame' position and interlock the control circuit. An air pre-purge will take place at this position for a pre-determined period, at the end of which the burner sequence controller will stop until the modulating unit has travelled to the 'low flame' position and interlocked the control circuit again. The sequence control will now recommence its operational cycle and the burner will light and remain at low flame until the high flame release signal is given by the sequence control.

# ELECTRICAL CONNECTION DIAGRAM

## Standard Terminal Connections For Burner Mounted Control Panels

(Please refer to the Wiring Diagrams packaged with the burner if a separate Control Panel is supplied)

For specifications and sizing of the electrical supply and interconnecting wiring please refer to the **Electrical Data Table** in the Appendix of this Handbook

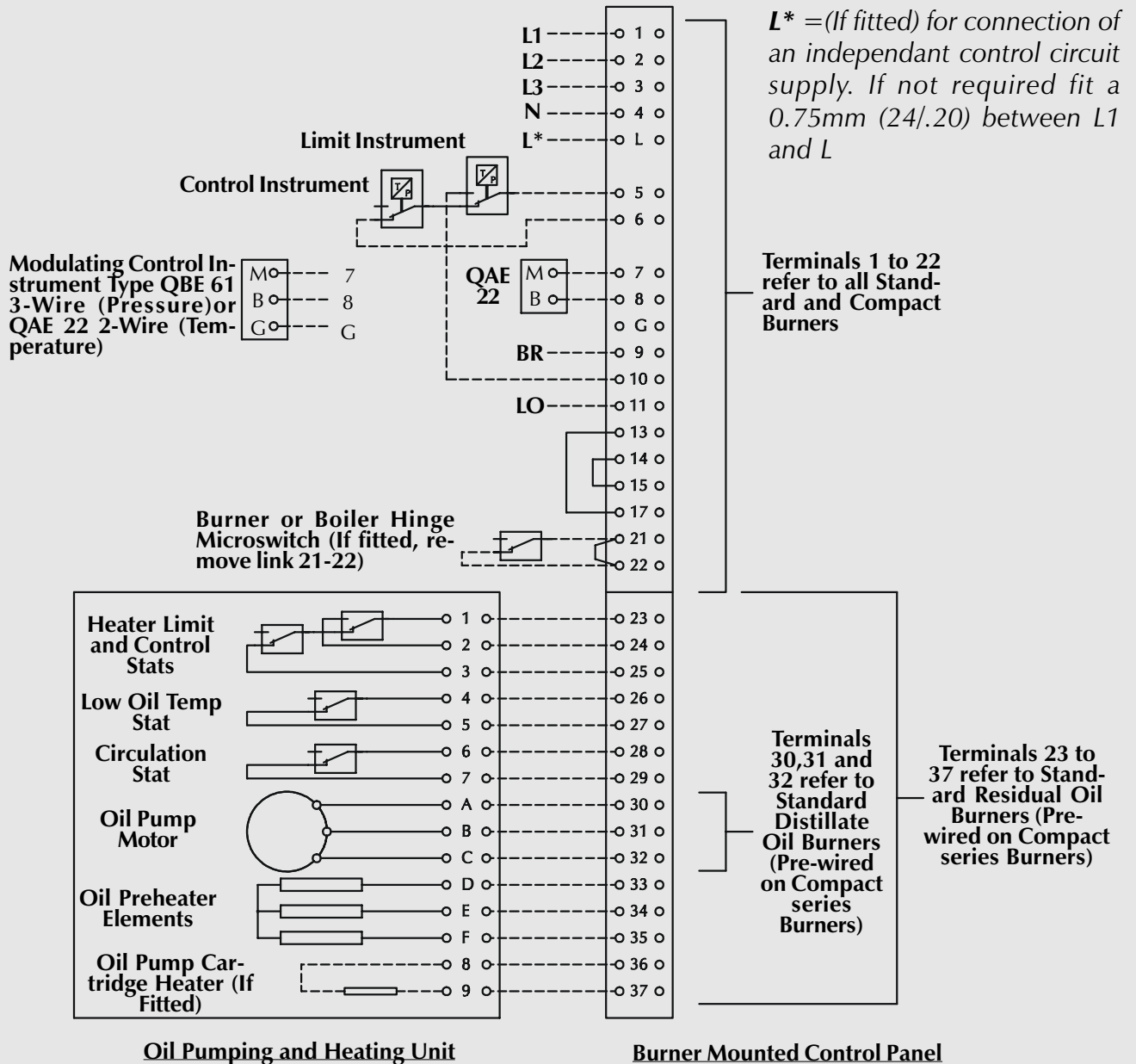

### Notes:

- For temperature control use Landis & Staefa detector type QAE 22 and for pressure control type QBE 61.
- Any interlock designed to switch or control the burner such as a time switch, damper or I.D. fan interlock etc. is to be wired in series with the control and limit thermostats.
- If the burner is used on a steam boiler, the water level interlocks must be wired between terminals 13 & 17 and the link removed.
- A remote 'Run' indication (BR) can be wired from terminal 9.
- A remote 'Excess Temperature or Pressure' alarm can be wired from terminal 10.
- A remote 'Lockout' alarm (LO) can be wired from terminal 11.
- A remote 'Oil Heater Tripped' alarm can be wired from terminal 24.

The modulating unit will now move to high flame and remain at this position until the desired boiler temperature/pressure is attained. From this stage the modulating unit will commence to move towards the low flame position, but, depending on the temperature/pressure, will stop in any intermediate position between low and high flame.

## **BURNER CONTROLS**

Burners are supplied with an integral control panel containing a sequencing control unit and the burner switchgear. On steam boiler applications an auxiliary control panel containing boiler feed pump controls, water level interlocks and alarms is available.

### Oil Pumping / Pumping & Heating Units

Standard burners are supplied with a floor mounted pumping (Distillate fuel) or pumping and heating unit (Residual fuel) for conditioning of the supply oil prior to entering the burner hydraulic circuit. Details of each unit are shown on page 15 opposite.

On burners supplied in 'compact' configuration, the pumping and heating equipment is mounted on the burner.

### Modulating Unit

The Nu-way modulating unit consists of a reversible servomotor, which is directly coupled to the camshaft of the modulating unit. Two adjustable cams are mounted on this shaft, one of which is connected to a flexible cable operating the burner air inlet control damper and is of the variable contour type (see fig. 2 on page 18). The second cam is the modulating oil cam and is illustrated in fig. 1.

The *Burner Oil System* Drawing on page 11 shows the hydraulic circuits for residual and distillate fuel burners. Oil for combustion is drawn from the supply through a fixed displacement pump and supplied direct to the burner nozzle. A return line from the back of the nozzle is connected to a 'spill regulating valve' which regulates the oil pressure at the nozzle according to the position of an internal piston which is actuated by the oil control cam in the modulating unit.

There is a well defined relationship between the delivery of fuel through the nozzle and pressure behind the nozzle, therefore movement of the oil cam 'modulates' the nozzle output and hence the output of the burner.

The volume of air required for combustion must also be varied as the nozzle output varies, and this is done by the air control damper operated by a flexible steel cable connected to a lever system bearing against the air control cam.

Once the oil cam has been adjusted as described in the *commissioning procedure* section of this handbook, the profile of the air cam is adjusted to give the desired combustion conditions by turning the thumbscrews under the cam in or out as the burner is 'inched' through its firing range.

The air control damper is spring loaded 'open' for safety in the event of cable failure.

### Residual Oil Heating Controls

A preheater and recirculation thermostat is fitted to the residual oil burner range (NOR).

The preheater contains three thermostats:

- (a) High limit thermostat
- (b) Control thermostat
- (c) Low limit thermostat (reverse acting)

The recirculation thermostat is fitted in the return oil line and will override the burner firing controls and start the burner oil pump in order to maintain the correct oil temperature in the nozzles and burner pipework.

The thermostats should be set to the temperatures specified in the following table.

Fuel Class	High Limit Thermostat	Control Thermostat	Low Limit Thermostat	Recirculation Thermostat
E	110°C	85°C	65°C	40°C
F	130°C	100°C	80°C	50°C
G	150°C	140°C	100°C	70°C

### Safety Features

Flame supervision is effected by photoelectric cell and sequence control box. An air pressure switch is fitted to prove that combustion air is available to the burner head before allowing the oil pump to start. (The oil pump is driven by a separate motor in all cases except for the smaller 'compact' design of burner)

# OIL PUMPING / PUMPING & HEATING SET

## Pipework Connections

Item	Description	R"
1	Oil Inlet Connection	1
2	Oil Return Connection	1
3	Burner Oil Feed	3/4
4	Burner Oil Return	3/4

## Distillate Oil Pumping Set

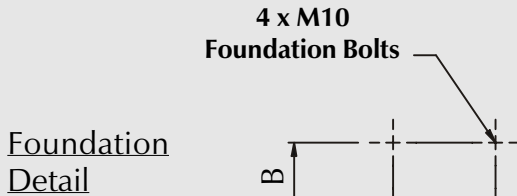
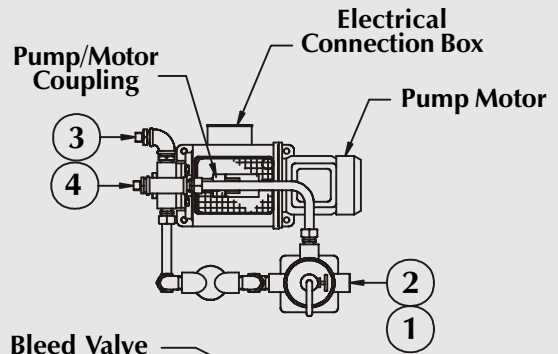

## Foundation Detail

Burner Model	A	B
Up to NOL50	223	152
NOL60 to 150	220	194

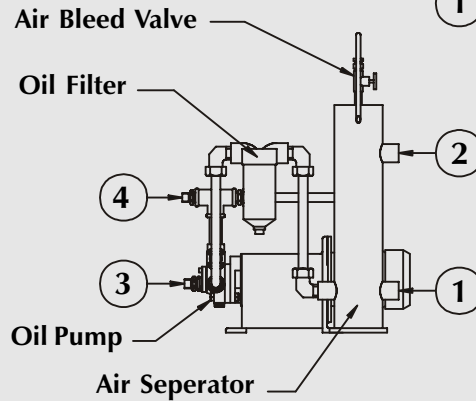

## Residual Oil Pumping & Heating Set

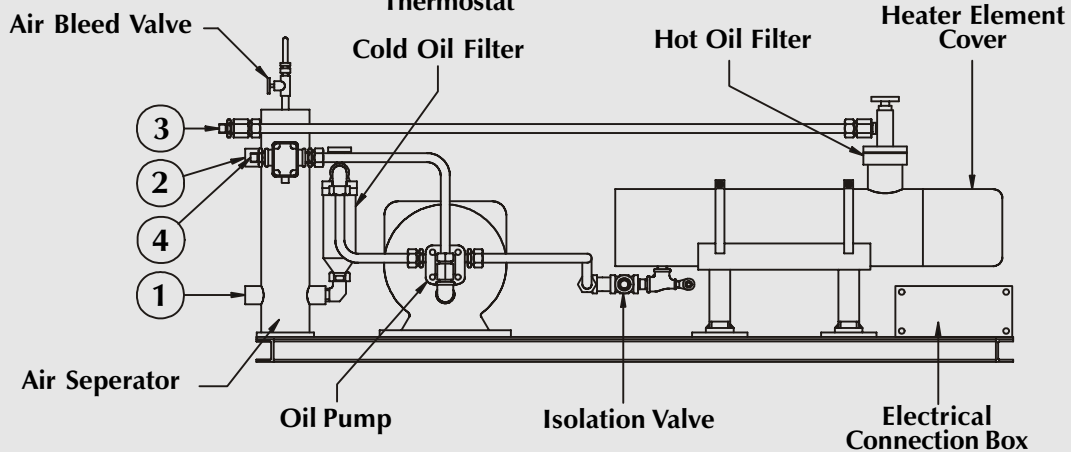
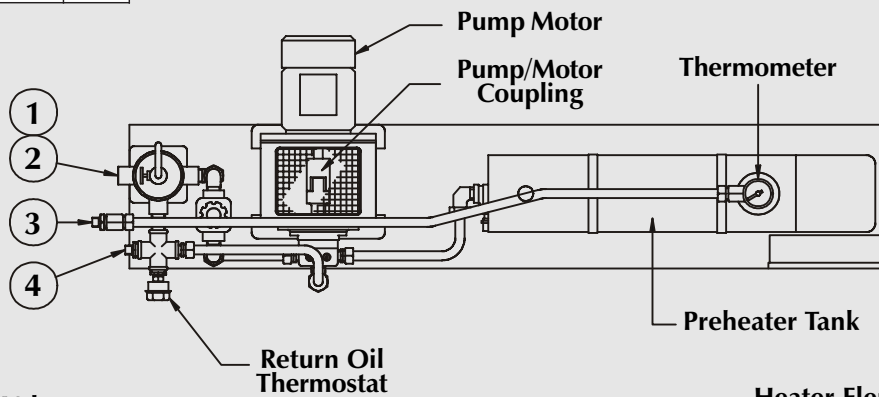

## Foundation Detail

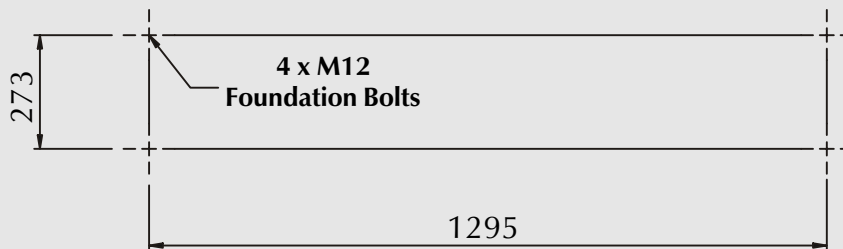

# COMMISSIONING

## IMPORTANT - SAFETY

It is essential that commissioning shall be undertaken only by suitably qualified and experienced personnel. In the case of NO Modulating burners, commissioning engineers should be experienced in pressure jet oil burner commissioning. Nu-way can accept no responsibility for consequential loss, damage or personal injury which results from a failure to follow the commissioning instructions provided or from commissioning procedures being undertaken by unqualified personnel.

## EMERGENCY INSTRUCTIONS

NO Modulating burners are designed and constructed to meet current legislation. When used in accordance with the instructions provided, NO Modulating burners are unlikely to produce a hazardous condition. If, however such a condition should arise in connection with the burner, the appliance or of any instrument, machine or service in the vicinity of the burner, the **OIL AND ELECTRICITY SUPPLIES SHALL BE ISOLATED IMMEDIATELY** and they shall remain isolated until the fault has been identified and rectified.

## Inspection

Before commissioning is begun it is important to:

- Check that the electrical wiring is complete and complies with all applicable Codes and Standards.
- Ensure that the fuses are fitted and are of the correct rating.
- Check electrical earthing.
- Verify that the oil supply system is correctly designed and that the supply pipework is correctly sized and free from leaks.
- Ensure that all manual fuel isolation valves are operable, fully closed and leak tight.
- Make all personnel involved in the commissioning aware of the location of the emergency fuel and electricity isolation points.
- Check that fittings for bleed and pressure testing are fitted.
- Establish that the appliance is in an appropriate and safe condition to be fired; for example, that there is water in the boiler.
- Set the appliance controls to call for heat.
- Check the appliance's ventilation and flueing arrangements.

- Ensure that any warning notices appropriate to the commissioning procedure are in position.
- Ensure that all necessary tools and test equipment are available and ready for use. Essential items include temperature measuring instruments for measuring flue gas and appliance water temperatures, and a means of analysing the flue products for carbon dioxide (CO<sub>2</sub>), oxygen (O<sub>2</sub>), carbon monoxide (CO) and smoke.
- Check that all relevant documentation is available including, where appropriate:
  - The agreed plant performance specifications.
  - Plant drawings and pipework layouts.
  - Electrical logic and wiring diagrams.
  - Certificates confirming satisfactory completion of procedures such as soundness testing and electrical safety tests.
  - Commissioning, operating and maintenance instructions for the plant.
- Establish that the operation of plant other than being commissioned will not have an adverse effect on the operation of the plant to be commissioned and similarly, that the operation of the plant to be commissioned will not have an adverse effect on other plant.  
Confirm that the operation of adjacent plant and machinery will not constitute a hazard to the personnel involved in commissioning.

## Pre-firing Checks

With the oil and power switched off, carry out the following checks.

- Check the nozzle size and position relative to the diffuser plate. (The burner head dimensional details are given in the *appendix* of this handbook).
- Check that the electrode positions and H.T. leads are correct.
- Check all the motor overload settings.
- If the appliance is a boiler, check that the water level is correct, the controlling valves are open and that the water pumps are in working order.
- If a flue damper is fitted, check that it is correctly interlocked to the burner or fixed in the fully open position.



- Ensure that there is a good oil supply to the burner pump. Bleed one or two gallons from the flexible to eliminate any pipe scale and air from the system.
- Check that the oil supply is of the recommended temperature and pressure.
- Bleed the burner pump manually by removing the right hand 1/4" BSP plug in the top of the pump until air-free oil flows.
- Fill the oil pre-heater tank, if fitted, by removing the hot oil filter retaining flange in the outlet pocket on the top of the tank. Fill to the neck of the tank outlet with clean fuel oil only.
- Switch on the electricity supply to the burner and check that the pump motor rotation is correct to the direction arrows shown on the pump face.
- Remove the access lid on the modulating cam box unit.
- Switch on the burner at the control panel. (If an oil pre-heater is fitted, then a delay may be experienced whilst the system attains temperature). The modulating unit camshaft should now rotate to the high flame setting, and the combustion air motor will start the air pre-purge phase.
- Allow the fan motor to run up to speed, switch off the burner and check the fan rotation (Anti-clockwise as viewed from the motor side) as the fan slows down.
- Remove and cover the photoelectric cell with a clean lint free cloth, switch on the burner, and allow it to run through to lockout. During this run check that the ignition spark is occurring, and note the spill and line oil pressures at the moment of ignition. Reset the sequence control and repeat the run if necessary to check these functions. If necessary, adjust the spill pressure to the correct figure according to the nozzle specification and the line pressure at the burner pump to 27.8 bar (400 psi).

## THE BURNER IS NOW READY TO BE COMMISSIONED.

### Hand Auto Selector Switch

This switch must always be in the 'Auto' position when the burner is required to start. The 'Hand' selection can be made immediately the burner has started to fire.

Should the burner be left in the 'Hand' position it will **NOT** modulate until the 'Auto' position is selected.

### Commissioning the Burner

New NO Modulating burners are generally supplied against the firing specification of the appliance. In this case the system and spill pressures may be pre-set and require checking and minor adjustments only. The following section describes how to set up the modulating cam box unit from a 'scratch' situation.

The modulating cam layshaft can be rotated by hand by using the gearbox disengagement lever in the drive servomotor.

- Ensuring that the modulating cam arrangement is in the low flame position, adjust the oil cam (see fig. 1 on page 18) so that it gives approximately 1.5mm throw (3mm stroke) and lock in position.
- Check to ensure that the spill valve push rod bears lightly against the oil cam.
- Turning to the air cam (fig. 2 on page 18), rotate the thumbscrews in or out so that they give a reasonable amount of adjustment in each direction. Adjust the flexible cable (at either end if necessary) until the air inlet damper is fully closed (i.e. until all the slack is taken up on the cable).
- Now adjust the thumbscrews to give a small opening of the air damper at low flame.
- Uncover and replace the photocell. Reset the sequence control and allow the burner to start. Immediately the burner starts, switch the hand/auto selector switch to the 'hand' position and hold low flame until the appliance is ready to accept high flame. During this period, check and adjust the low flame oil throughput.
- Check the flame visually. If the flame is dirty, adjust the air cam thumbscrews until the flame becomes clean.
- After a suitable delay, inch the camshaft to the high flame position (i.e. through 180) by means of the inching switch on the control panel. Adjust the air cam profile by means of the thumbscrews until the air damper is now fully open. At this stage it will be found that all of the thumbscrews between low and high position will require adjusting so as to avoid over stressing the cam profile band.

# MODULATING UNIT

(Cams shown in the Low Flame Position)

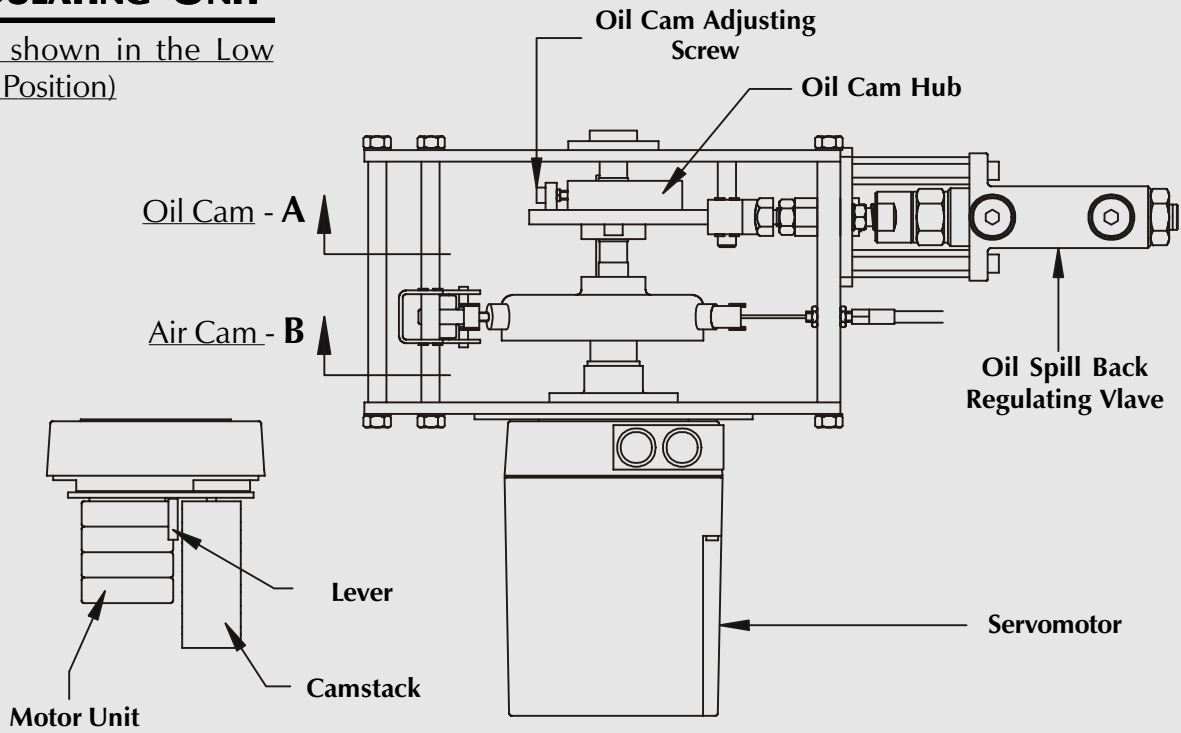

View of Servomotor from underside (cover removed) showing position of disengagement lever

Oil Cam View On - A  
Fig. 1.

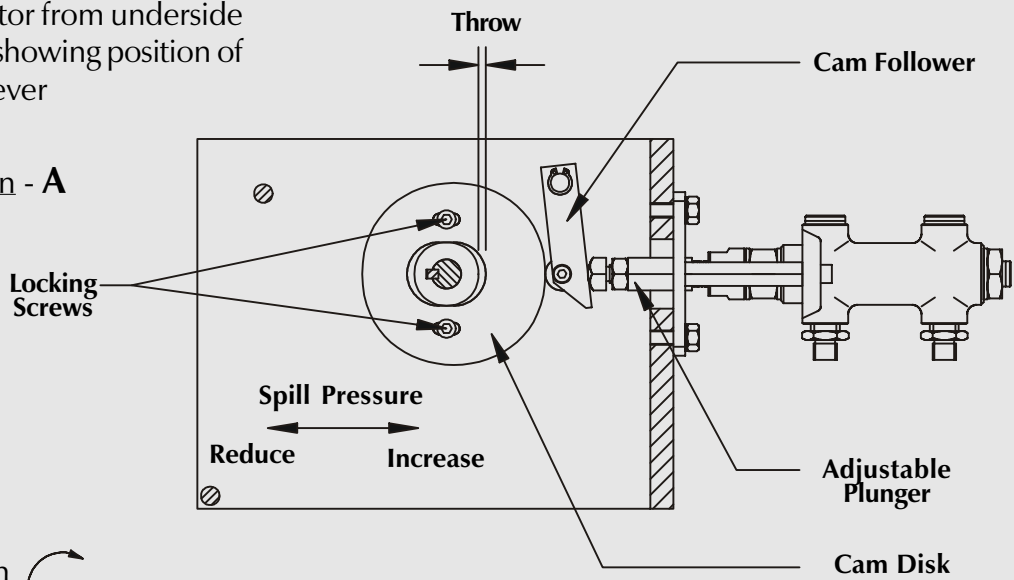

Rotation for High Flame position

Air Cam View On - B  
Fig. 2.

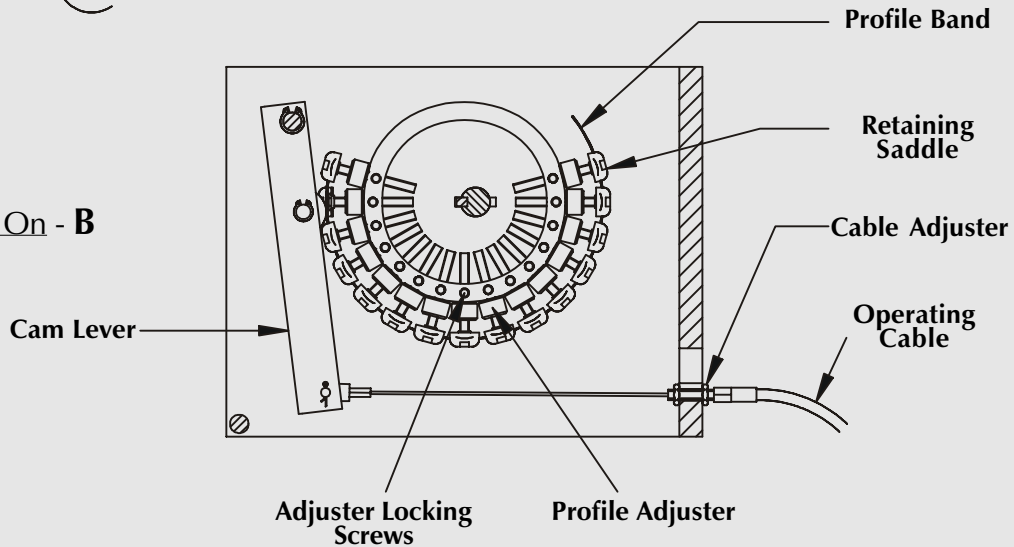

Once this has been done, there should be a fairly smooth profile between low and high positions.

Ensure that the flame is visually clean throughout the modulation range at all times.

Check the oil consumption. If this is not correct for the full burner rating, the oil cam must be adjusted as follows.

- (a) In the burner to low flame and note the spill pressure.
- (b) To increase the minimum rate, adjust as shown in fig. 1.
- (c) Adjust the cam to give more eccentricity for more oil at high flame, and visa-versa.
- (d) Return to the minimum setting and compensate for any changes.
- (e) In the burner to high flame and again check the oil flow.

Continue to repeat (a) to (d) until the high flame oil rate is correct.

When a satisfactory flame is achieved, again check the line and spill pressures. Check the pre-heater temperature (if fitted) and adjust if necessary.

- In the camshaft back to the low flame position. The oil consumption rate should now be between 35 and 50% of the rated maximum.
- Measure the flue gas composition and adjust the combustion air volume as necessary.
- Check the burner performance throughout the range adjusting the air cam profile as necessary to give a clean and efficient flame.

When a satisfactory setting has been achieved, lock the air cam thumbscrews with the grub screws fitted in the side face of the cam body. Refit the Modulating unit access cover.

Check the function of the air pressure switch.

- Switch off the electrical supply to the burner.
- Remove the air pressure switch cover. Fit a manometer to the pressure switch to check the actual air pressure against the pressure switch dial setting.
- Switch on the electrical supply and allow the burner to establish low flame.
- Select 'Hand' control and ensure that the burner is at low flame by using the inching switch.
- Slowly turn the air pressure switch adjusting dial clockwise until the flame is extinguished. The burner will go to lockout.

- Turn the dial one division anticlockwise and reset the burner lockout. The burner will now continue through its cycle until flame is established or the burner goes to its lockout position. If the burner goes to lockout repeat the procedure one division per burner cycle until flame is established. Once successful, turn the dial a further two divisions anticlockwise.
- Switch off the burner electrical supply, replace the air pressure switch cover and remove the manometer.

If the burner control panel is inclusive of Low – Excess low and High Water interlocks and alarms, test that these function correctly. Ensure that the boiler feed pump switchgear provided in the panel is operating satisfactorily.

Adjust the modulating control to the required pressure/temperature.

Allow the boiler to attain the correct working pressure/temperature and adjust the on/off and limit instruments to the desired values.

Switch the Hand/Auto selector switch to 'Auto'. The plant is now under the control of the pressure/temperature controllers for modulation and the on/off and high limit instruments for control.

On residual oil burners, check the operation of the three oil temperature thermostats fitted in the end of the preheater tank element, and the re-circulation thermostat (class G fuel only).

Finally check all ancillary controls and equipment such as damper interlocks etc.

## **ROUTINE MAINTENANCE OF NOL/ NOR MODULATING BURNERS**

---

### **General**

---

It is vitally important that personnel responsible for the day to day operation and maintenance of the plant are instructed by the commissioning engineer on the basic function of the burner as well as the need for routine maintenance and daily checking of burner operations.

Final adjustments, which will have been made during the commissioning, must be recorded on the *Commissioning Sheet* at the back of this manual and in the appliance **logbook**. A copy of the commissioning data **must** be sent to the appliance manufacturer.

The burner should be kept clean inside and out. It will be more reliable, and if an oil leak occurs it will be spotted more readily.

## Daily Checks

---

Inspect the burner daily to check if there is any variation from the correct operating sequence, as follows:

Check the oil pressure on the nozzle line gauge. This should be 27.8 bar (400 psi). On heavy fuel burners a drop in line pressure may indicate clogging of the hot oil filter which is situated in the outlet pocket of the pre-heater tank. Remove the filter by removing the four bolts from the outlet pocket flange and disconnecting the pipework. Lift the filter out and wash in kerosene. If the oil pressure remains low, then check the oil supply system, stop/fire valves, ring main pumps etc and also the cold oil filter(s).

Check the spill pressures. If these are low it may indicate that the oil nozzle filter is clogged.

If there is an inspection window on the appliance through which the ignition spark and flame can be observed, ignition and flame should be inspected and any irregularities that are observed should be rectified i.e. nozzle/electrodes cleaned and any deposits removed from the inside of the flame tube and diffuser.

## Cleaning the Oil Nozzle

---

To clean the oil nozzle, switch off the electricity supply to the burner and disconnect the flexible oil lines at the burner head quick release couplings. Remove the hinge plate retaining nuts and swing open the burner. Disconnect the H.T. leads and remove the two long cap head screws retaining the inner assembly, from the face of the oil manifold block on the side of the hinged extension. The inner assembly lance can now be removed complete with the diffuser and electrode assembly by withdrawing from the flame tube/hinge assembly. It is important that the nozzle is cleaned using non-abrasive materials, never use anything which may scratch the finely finished surfaces of the nozzle.

**Nozzle life is approximately 5000 hours operation**, after which wear will affect atomisation and plant efficiency will drop.

## Photoelectric Cell

---

Remove the photoelectric cell and clean with a soft lint free cloth if necessary. Be carefull not to touch the glass buld of the cell as this can lead to premature failure of the unit.

## Cold Oil Filter(s)

---

On residual oil burners, rotate the cleaning knob of the cold oil filter daily.

The plug in the bottom of the filter housing should be removed and sludge water drained off at intervals not exceeding six weeks. If a duplex cold oil filter set is fitted, the filters can be alternated and isolated for cleaning operations as necessary.

On distillate oil burners, the filter bowl should be removed and the filter element cleaned in kerosene every six months. If the filter has a disposable element renewal should be considered.

## Replenishing the Fuel Supply

---

It is usual practice to shut boiler(s) off whilst delivery of fuel is being made and allow approximately 30 minutes for any sediment to settle before re-starting the burners.

## Boiler Combustion Surface

---

Keep the boiler combustion surfaces and flueways clean. Any accumulation of soot will decrease the efficiency of the boiler and increase the flue gas exit temperature. Always cover up the burner during boiler cleaning operations.

## FAULT FINDING

---

### If the Burner Fails to Start

---

Make sure that all the thermostats and switches in the control circuit are in the 'made' position and that the oil pre-heater 'excess limit' thermostat has not tripped. Reset if required. Check that the low oil temperature thermostat is set correctly for the appropriate fuel.

Check that the electricity supply to the burner is 'live' and that the control and main circuit fuses are intact. If a fuse is found to be 'blown' then the cause should be investigated and rectified before proceeding further.

On steam boilers, check that the 'water level interlocks' are in the 'made' position.

### If the burner is found at lockout (red lockout lamp illuminated)

---

Reset the burner and observe the starting sequence. (Make reference to the *Sequence Diagram and Timing Charts* for the Flame Failure controls on page 23 for further information).

Check the fan and oil pump motor overloads and reset if necessary.

Check the operation of the air pressure switch, Failure of the switch to operate prevents the oil pump from starting.

### Flame Occurs Followed by Immediate Lockout

Check the PE cell and the air regulator for correct operation. Check that the oil pressures are correct. If necessary, check and clean the preheater hot oil filter, ensure that there is sufficient oil in the storage tank, bleed the oil pump in case it is partially air-locked. Check to ensure that all stop/fire valves in the supply line are fully open. Check residual fuel oil temperature – check the ring main for correct operation in respect of temperature and pressure.

### The Burner Starts With The Correct Oil Pressure But No Flame Appears

Check the ignition system, HT lead connections, electrode gap and the condition of the electrode insulators. Check that the nozzle cut off is functioning and that the air damper cable is not broken or disconnected (the air regulator will be fully open). **It is important to note that continued re-setting of the burner should be avoided as this can lead to a dangerous situation.**

### Modulating System

If malfunction of the modulating controller (RWF 32) is suspected, check that only compatible components such as the range insert and pressure/temperature detector have been used. If problems persist then replacement of the unit should be considered.

### Burner Commissioning Sheet

This manual contains a record of the essential information and will have been completed by the commissioning engineer with individual details of the burner. These details should be verified periodically and adjusted if variations are noted. Commissioning details must also be recorded in the **appliance logbook**.

## **FUEL PUMPS**

### Danfoss Series KSA Fuel Pumps

The pump dataplate gives direction of rotation and connection port details.

P = nozzle line connection.

S = suction line connection.

R = return line connection.

The pump is also fitted with two measuring ports, Pn for nozzle pressure and Ps for suction/feed pressure.

Ports P, Pn and S, Ps become opposite hand when pump rotation is reversed.

Fig. 3. on page 22 shows the respective connections for counter-clockwise pumps, as viewed from the shaft side.

A hydraulic pressure-regulating valve is built into the pump to maintain constant pump pressure, however the valve has no cut-off function.

All KSA pumps are designed for 2-pipe operation and therefore should always be connected to the return line on the fuel supply system. When using a positive pressure single pipe system, as on distillate fuel, the return port is connected to the supply in the form of an external bypass.

### Suntec Series TA Fuel Pumps

Refer to fig. 4. on page 22 for the respective connection details.

A hydraulic pressure-regulating valve is built into the pump to maintain constant pump pressure. On the TA pump the valve has a cut-off function.

Suntec TA pumps can be used on one and two pipe systems dependant on the fitting of an internal bypass plug. The is removed for single pipe systems.

### Suntec Series TV Pressure Regulating Valve

The TV valve is designed for use with the Suntec series 'T' fuel pumps. (Refer to fig. 5. on page 22).

This separate pressure-regulating valve, which is installed in the nozzle line, is designed to keep constant pressure even if the output capacity is changed. A built in dampening device absorbs vibrations in the valve, effectively eliminating pulsations in the nozzle line.

Pressure adjustment for both TA and TV units is the same.

Remove the cap nut (1), washer (2) and loosen the locknut (4). Turning the screw (3) counter-clockwise will decrease the nozzle line pressure and visa-versa. After adjustment, tighten the locknut and refasten the washer and cap nut.

**Note:** the maximum allowable pressure for model TA5 is **30 bar**.

# OIL PUMP DETAILS

## General Notes:

Refer to the section Fuel Pumps on page 21.

Pump rotation is quoted by the direction of the pump shaft as viewed from the shaft side. The direction arrow embossed on the face of the pump or pump nameplate is therefore the reverse of the quoted rotation.

The Oil Pump is completely pre-piped as part of the pumping or pumping and heating set.

Should the Oil Pump performance become suspect then a replacement unit should be obtained and the Oil Pump returned to determine its serviceability.

Upon replacement refer to the pump bleeding instructions in the section Pre-firing checks on page 17.

Further details regarding the Oil Pump unit can be supplied on request.

Item	Description
S	Suction Port
P	Pressure Port
R	Return Port
Pn	Vacuum Gauge
Ps	Pressure Gauge
T	Regulator
I/O	Inlet/Outlet
1	Regulator Capnut
2	Washer
3	Regulator Screw
4	Locknut

Ports S, P, R & I/O are R.3/4"  
Ports Pn & Ps are R,1/4"

Fig. 3.  
Danfoss Series KSA  
Fuel Pump

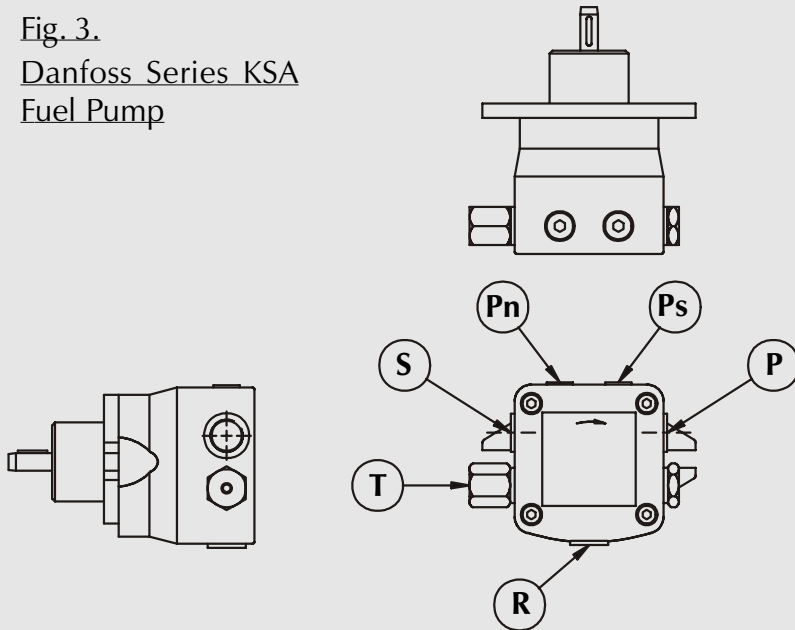

Fig. 4.  
Suntec Series TA  
Fuel Pump

(The porting arrangement is similar for Suntec series 'T' pumps, The 'T' pump however, must be used in conjunction with the TV regulating valve)

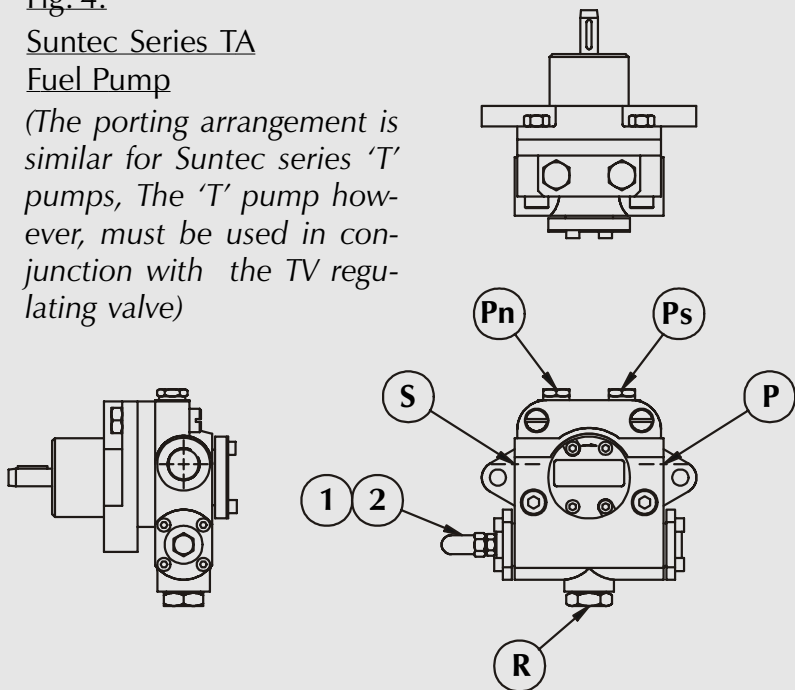
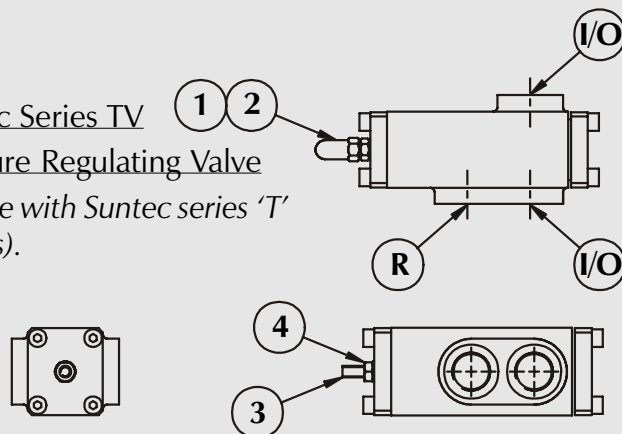

Fig. 5.  
Suntec Series TV  
Pressure Regulating Valve  
(For use with Suntec series 'T' pumps).



## Oil Pumps - Where Used

BURNER MODEL	DISTILLATE PUMP UNIT	RESIDUAL PUMP UNIT
NO 18-38		
NO 35-34	DANFOSS KSA1000 1425 RPM 350 L/HR	DANFOSS KSA1000 1425 RPM 500 L/HR
NO 35-38		
NO 50-28		
NO 50-34		
NO 50-38		
NO 60-28	SUNTEC TA5 1425 RPM 680 L/HR	SUNTEC TA5 1425 RPM 680 L/HR
NO 60-34		
NO 60-38		
NO 85-38		
NO 100-38	SUNTEC T3 1425 RPM 720 L/HR	SUNTEC TA5 1425 RPM 680 L/HR
NO 100-41		
NO 100-44		
NO 125-36	SUNTEC TA5 2850 RPM 1150 L/HR	SUNTEC T3 1425 RPM 950 L/HR
NO 125-41		
NO 125-44		
NO 150-36	SUNTEC T2 2850 RPM 1400 L/HR	
NO 150-41		
NO 150-44		

## FLAME FAILURE & SEQUENCE CONTROLS

The standard control box fitted to the NO Modulating series of burners is the Landis & Staefa type LAL1.

The unit is designed to provide control and supervision for atomising oil burners of medium to large capacity. They are suitable for use on multi-stage and modulating burners.

For safety reasons, at least one controlled shut-down must be provided within each 24-hour period of continuous operation.

When a burner failure is encountered the box goes into lockout mode. This is indicated by an orange neon, which displays within the lockout window of the control and is repeated at the lockout lamp on the panel facia.

If a lockout situation occurs, the burner will not start until it is manually reset by pressing the lock-out window on the control. (The control can also be reset by the off/on/reset switch situated on the control panel facia)

If the burner fails to fire and persists in locking out, **no more than three attempts should be made.** To do so will almost certainly create a **dangerous situation.**

If a burner becomes troublesome then the assistance of a qualified commissioning engineer should be obtained. To assist in his diagnosis, notes should be made detailing the events leading up to the lockout situation. The symbol appearing in the lockout window should also be noted prior to re-setting the burner. (Refer to the Sequence Diagram and Timing Chart below).

**PLEASE NOTE.** When the control box goes to lock-out it is generally performing the function it is designed for.

### Burner Control Program

Burner operational sequence based on the Landis & staefa LAL1.25 Control box. Note. Timings are for operation on a 50 hz electrical supply only.

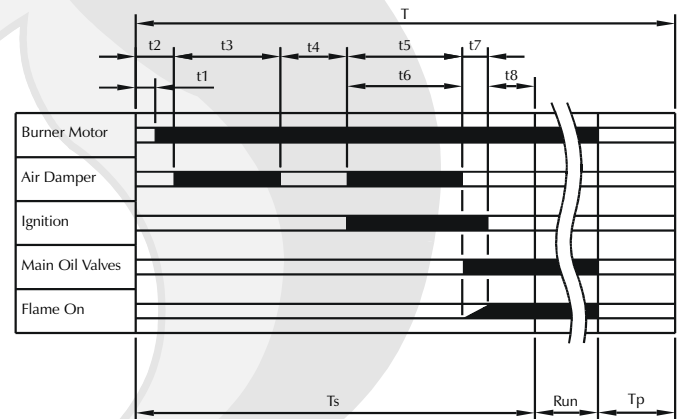

Period	Time (secs)	Description
t1	2.5	Start up time for fan motor
t2	5	Start up to 'open' signal
t3	54	Modulating servo to 'High flame'
t4	22.5	Full air pre-purge
t5	54	Modulating servo to 'Low flame'
t6	54	Pre-ignition
t7	5	Safety period
t8	15	Release to RWF 32 Controller
Ts	155.5	Total start up time
Tp	15	Post purge time
T	170.5	Control re-cycle time

## Control Program Under Fault Conditions And Lockout Indication

In the event of fault conditions the sequence switch stops and simultaneously the lockout indicator. The symbol appearing above the reading mark indicates the kind of fault encountered.

- ◀ **No start**, because, e.g., the CLOSE signal has not been supplied to control box terminal 8 by the servo motor limit or auxiliary switch, or a contact has not been closed between control box terminals 12 and 4 or 4 and 5.
- ▲ **Shut down of start up sequence**, because the OPEN signal has not been supplied to control box terminal 8 by the servo motor limit switch. Terminals 6,7 and 15 remain under voltage until the fault is corrected.
- **Lockout** due to a fault in the flame supervision circuit.
- ▼ **Shut down of start up sequence**, because the signal for the low flame position has not been supplied to control box terminal 8 by the servo motor auxiliary switch. Terminals 6,7 and 15 remain under voltage until the fault is corrected.
- | 1 **Lockout**, because no flame signal has been received on completion of the safety time.
- | **Lockout**, because the flame signal has been lost during burner operation or an air pressure failure has occurred.
- ◀ **Lockout on completion or after completion of the control program sequence** due to extraneous light (e.g. flame not extinguished, leaking fuel valves) or due to a faulty flame signal (e.g. fault in the flame supervision circuit or similar).

When lockout occurs, the control can be reset immediately. After the resetting (and also after the correction of a fault which resulted in a controlled shut-down, or after each mains failure) the sequence switch always runs through to the start position, whereby **only** terminals 7,9,10 and 11 receive voltage in accordance with the control program. It is only then that the control unit programs a fresh burner start up.

**Note:** Do not press the lockout reset button (or remote reset switch) for more than 10 seconds.

## MODULATING CONTROL

### Landis & Staefa RWF32

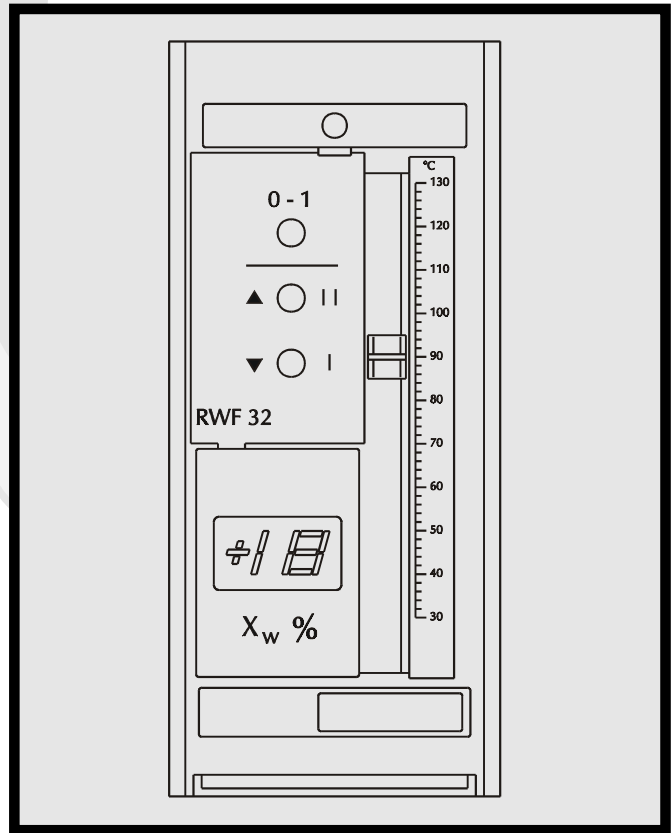

Landis & Staefa  
LAL1. Program  
Sequence Disk.

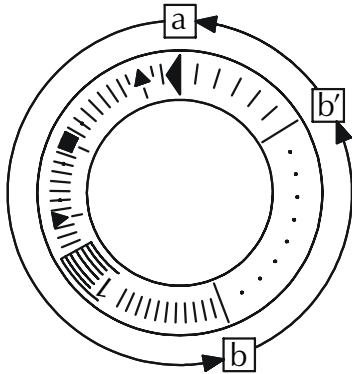

- a - b** Start up sequence.
- b - b'** idle steps up to the self shut down of the sequence switch.
- b(b') - a** Post purge sequence.

The RWF32 controller has been specifically designed for the control of boiler temperature or steam pressure in Oil and Gas fired plant.

The unit is normally mounted in the side face of the burner panel and is protected by a clear plastic cover which can be swung downwards.

By using the appropriate **Setting Range Insert**, the controller is configured for a controlling value and required setting range. This setting range insert forms part of the measuring bridge on the detector side and also carries the setting scale. The setting unit itself is an integral part of the controller.



In addition to the setpoint setting slider, further setting controls are located beneath the silver fascia plate situated above the digital display unit. All the settings can be adjusted whilst the burner is in operation.

Three LED's indicate the following operational status:-

- Control **ON / OFF (0-1)**
- Control Pulse **OPEN (II) / CLOSED (I)**

The digital display below the LED's gives the set value / actual value deviation as a percentage of the inserts setting range up to +/- 19%. Measuring and display take place at 2 second intervals and in 1% steps.

### Setting

The setting slider should be adjusted to the setpoint temperature or pressure.

before further adjustments are made: -

**RWF32 Recommended Settings**

Fig. 6.

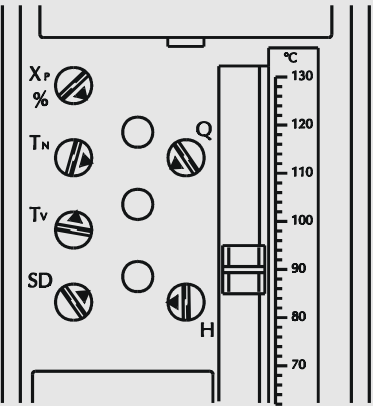

PARAMETER	HOT WATER BOILER SETTING	STEAM BOILER SETTING
Xp	20%	5%
Tn	50 secs	20 secs
Tv	1	3
Sd	9%	9%
H	1.5	1.5
Q	10	5

- Write down the setting values found on the control units supplied.
- Alter only one parameter at a time (i.e. do not alter Xp, Tv and Tn at the same time) !
- Make corrections in small steps only.
- Make further adjustments only after the previous adjustment has produced a clear reaction.
- An Increase in the parameter Xp produces greater control stability but slows down the system response to load or setpoint changes.
- A decrease in the parameter Xp improves the systems response to load changes, but the control stability may suffer, i.e. control oscillations may occur.

Commissioning of the plant will be considerably simplified and accelerated when, during the setting operations, the load conditions can be kept fairly constant, thus making it easier to clearly recognise the control system's response to load or setpoint changes.

For most general applications we recommend the settings listed in the table in fig. 6. However should these settings not prove to be sufficient then the following procedures can be carried out.

### Adjustments in the case of a slow correcting response.

Reduce the set values in a step wise fashion, allowing the system time to settle before making further adjustments. Firstly reduce only Xp (down to 5%). If this is not satisfactory then reduce Tv (down to 0) and finally Tn.

### Adjustments in the case of an excessively fast correcting response.

Usually in connection with control oscillations, the selected set values should be increased in a step wise fashion, again allowing the system to stabilise before proceeding further. Firstly increase Xp, then Tv (up to approx. 3) and finally Tn until stability is reached.

A data sheet containing in depth information on the RWF 32 and its operation is available upon request.

## BURNER OIL NOZZLE

The Burner lance is designed to operate spill-back atomisers having a spring loaded orifice shut-off needle and a 7/8" x 20 unef fixing thread.

The Fluidics W1 series atomiser is the preferred type and this will have been sized at the point of order to suit the burner rating and application.

When the nozzle has completed 5000 hours of operation, it should be replaced with the same **Make, Type and Size** as fitted. Failure to do so will alter the characteristics of the burner and may impair the performance and efficiency of the plant.

The nozzle identification code is stamped onto the face of the hexagonal nut section of the nozzle body as shown in fig. 7. above.

Should any doubts arise concerning the suitability or performance of the burner nozzle, please contact the Nu-way Technical dept. who will be pleased to assist.

## SERVICE & REPLACEMENT

Nu-way Ltd Parts & Components Division carry a comprehensive stock making up the burner systems described in this handbook. Should it become necessary to order replacement parts, it is important to quote the burner model, specification and serial numbers to ensure correct expedition of your order.

Nu-way Ltd is able to offer 'on site' Commissioning, Service and Repair through its worldwide network of authorised distributors and sales offices. Please contact the Nu-way Service Department for further information.

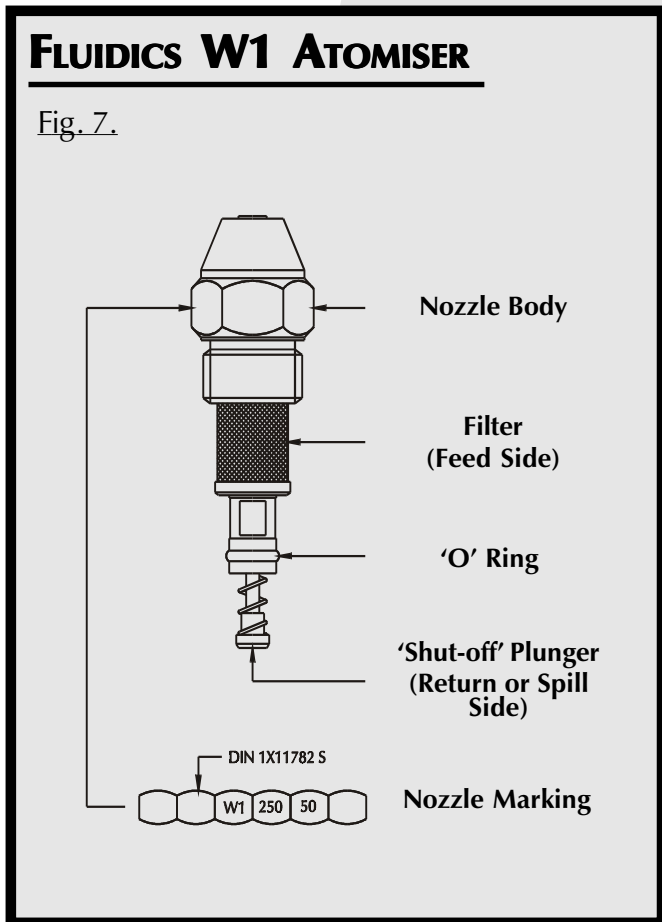

**Burner Performance Graph**

All Outputs Quoted Are Based on Gross C.V.

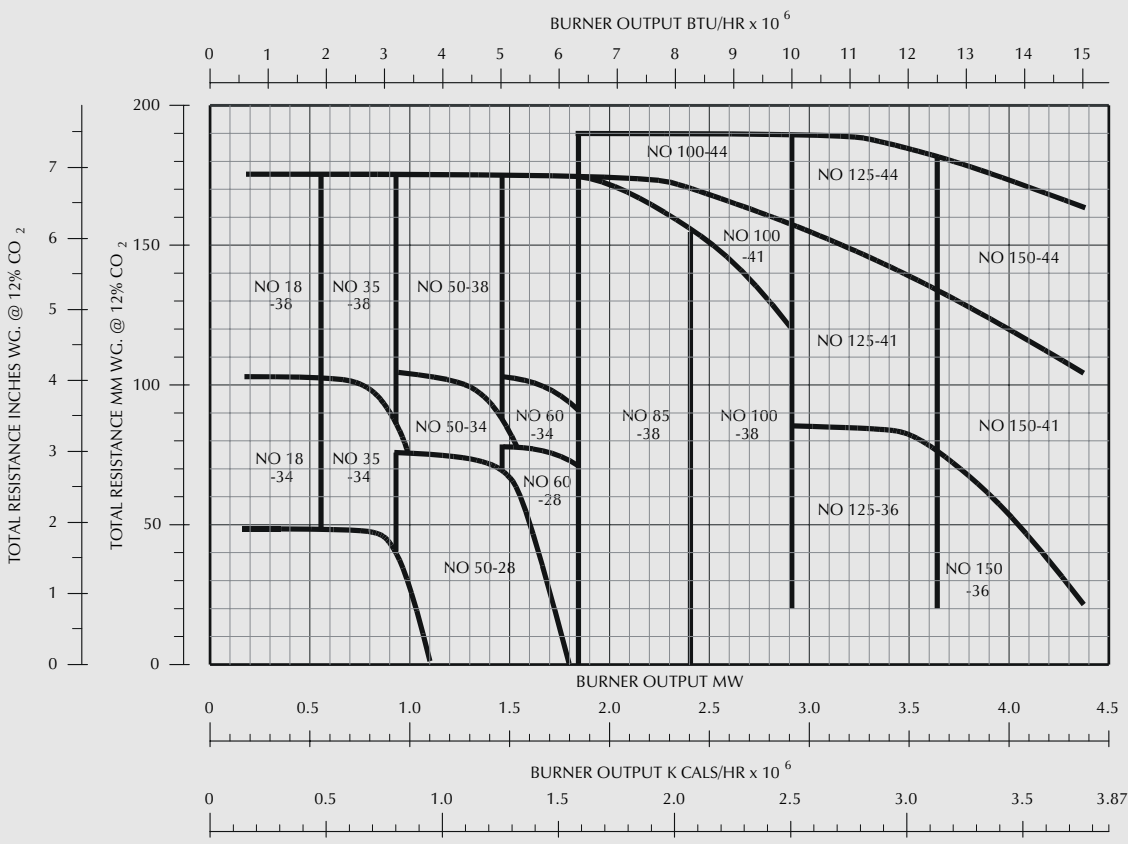

## Burner Performance Graph

The Performance Graph shown on page 24 plots burner input against the appliance running resistance. The appliance starting resistance is derived from a combination of the combustion chamber shape, volume, start rate and flue conditions. It may be necessary to select a burner with a higher fan static pressure than would normally be chosen, if the appliance has a high starting resistance.

Similarly, when firing a reverse pass boiler up to 2 MW, with a combustion intensity of 2 MW/M<sup>3</sup> and an operating resistance between 40 and 90 mm wg. it is recommended that a burner with a higher fan static pressure is selected, ie. if the graph selects a burner with a 28 cm fan then use the 34 cm fan model for correct combustion.

All outputs quoted are based on gross C.V.

### BURNER HEAD DETAILS & ELECTRODE SETTINGS

Shown in Plan Section Through Centreline

Burner Model	Dimension A
NO*18-34 to NO*100-38	64
NO*100-41 to NO*150-44	90

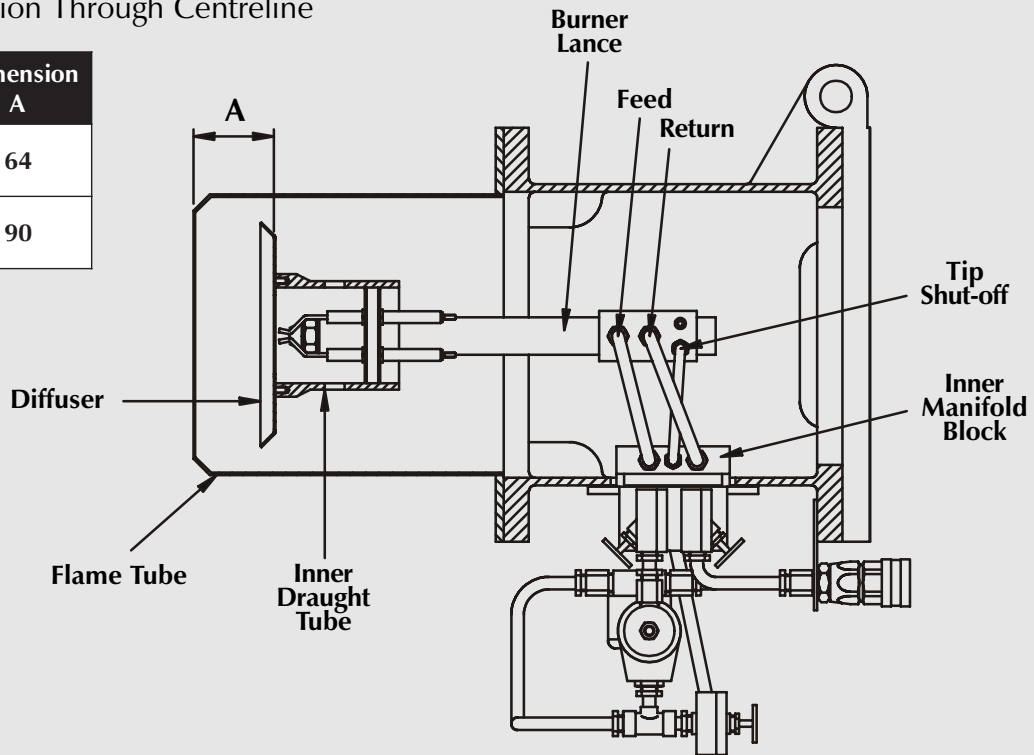

Electrode Setting

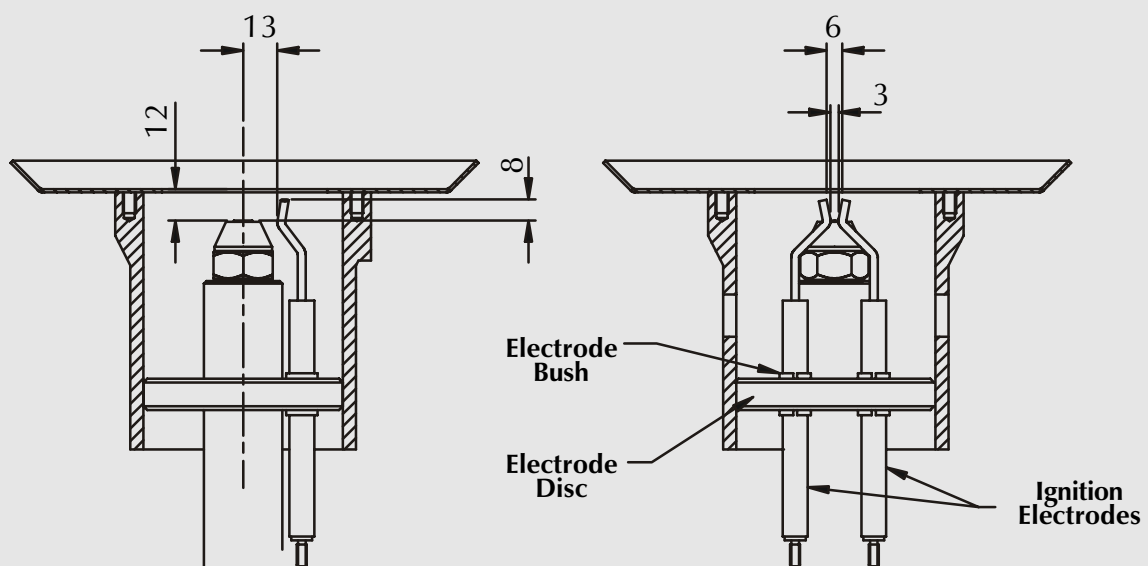

Section on Elevation

Section on Plan

Electrical Data Table

BURNER MODEL	FAN MOTOR		BURNER WITHOUT PRE-HEATER						BURNER WITH PRE-HEATER							
			PUMP MOTOR		Start current A/phase	Run current A/phase	Cable size (mm <sup>2</sup> )	HRC fuse (A)	PUMP MOTOR		Start current A/phase	Run current A/phase	Cable size (mm <sup>2</sup> )	HRC fuse (A)	Pre-heater kW	Cable size (mm <sup>2</sup> )
	kW	hp	kW	hp					kW	hp						
NO 18-38							2.5									
NO 35-34	3.0	4.0	0.37	0.5			2.5		0.37	0.5					7.5	1.5
NO 35-38	4.0	5.5	0.37	0.5			2.5		0.37	0.5					7.5	1.5
NO 50-28	2.2	3.0	0.37	0.5	32.0	5.6	2.5	20	0.37	0.5	42.0	16.0	4.0	30.	7.5	1.5
NO 50-34	3.0	4.0	0.37	0.5	42.0	7.0	2.5	25	0.37	0.5	52.0	17.4	4.0	40	7.5	1.5
NO 50-38	4.0	5.5	0.37	0.5	52.0	8.8	2.5	30	0.37	0.5	62.0	19.2	4.0	50	7.5	1.5
NO 60-28	3.0	4.0	0.75	1.0	46.0	7.9	2.5	30	0.37	0.5	52.0	17.4	4.0	40	7.5	1.5
NO 60-34	4.0	5.5	0.75	1.0	56.0	9.7	2.5	30	0.37	0.5	62.0	19.2	4.0	50	7.5	1.5
NO 60-38	4.0	5.5	0.75	1.0	56.0	9.7	2.5	30	0.37	0.5	62.0	19.2	4.0	50	7.5	1.5
NO 85-38	5.5	7.5	0.75	1.0	40.0	13.6	2.5	30	0.75	1.0	50.0	24.0	4.0	50	7.5	1.5
NO 100-38	7.5	10.0	1.5	2.0	50.0	17.8	4.0	40	0.75	1.0	60.0	26.9	6.0	50	7.5	1.5
NO 100-41	7.5	10.0	1.5	2.0	50.0	17.8	4.0	40	1.5	2.0	62.0	30.3	6.0	60	7.5	1.5
NO 100-44	11.0	15.0	1.5	2.0	65.0	25.0	6.0	50	1.5	2.0	82.0	41.7	10.0	80	7.5	1.5
NO 125-36	11.0	15.0	1.5	2.0	65.0	25.0	6.0	50	0.75	1.0	75.0	35.5	10.0	60	9.0	2.5
NO 125-41	11.0	15.0	1.5	2.0	65.0	25.0	6.0	50	1.5	2.0	77.0	37.5	10.0	60	9.0	2.5
NO 125-44	11.0	15.0	1.5	2.0	65.0	25.0	6.0	50	1.5	2.0	82.0	41.7	10.0	80	9.0	2.5
NO 150-36	11.0	15.0	1.5	2.0	65.0	25.0	6.0	50	0.75	1.0	75.0	34.1	10.0	60	12.0	4.0
NO 150-41	11.0	15.0	1.5	2.0	65.0	25.0	6.0	50	1.5	2.0	77.0	37.5	10.0	60	12.0	4.0
NO 150-44	15.0	20.0	1.5	2.0	85.0	32.0	10.0	50	1.5	2.0	95.0	44.0	16.0	80	12.0	4.0

# COMMISSIONING SHEET

The details below are to be completed by the Commissioning Engineer

Installer's Name : \_\_\_\_\_

Address : \_\_\_\_\_

Site Address : \_\_\_\_\_

Appliance : Type : \_\_\_\_\_ Rating : \_\_\_\_\_ Serial No. : \_\_\_\_\_

Burner : Type : \_\_\_\_\_ Rating : \_\_\_\_\_ Spec No. : \_\_\_\_\_

Serial No.: \_\_\_\_\_ Nozzles : \_\_\_\_\_ Oil Pump : \_\_\_\_\_

Commissioning date : \_\_\_\_\_ Guarantee Expiry Date : \_\_\_\_\_

Oil type : \_\_\_\_\_

Combustion Details	Low Flame	Point 2	Point 3	Point 4	Point 5	High Flame
CO <sub>2</sub> %						
Smoke N <sup>o</sup> .						
Ambient Temp. °C						
Flue Gas Temp. °C						
Efficiency. %						
C.C.P. mm/wg						
Flue Draught. mm/wg						
Fan Static. mm/wg						
Oil Pressure. bar						
Spill Pressure. bar						
Oil Temperature. °C						
Oil Consumption. us/gph						
Air Control. % Open						
Motor FLC. Amps						

Engineers Name : \_\_\_\_\_

Signature : \_\_\_\_\_ Date : \_\_\_\_\_

# BURNER MODIFICATION RECORD

---

Date	Details of Modification



P.O.Box 1, Vines Lane, Droitwich, Worcestershire, WR9 8NA, England

Telephone: (01905) 794242 (Direct Dial), (01905) 794331

Facsimile: (01905) 794017 & Spares (01905) 795829

email: [info@nu-way.co.uk](mailto:info@nu-way.co.uk)