

## **5. INVERTER MULTI-SPLIT SYSTEM ROOM AIR-CONDITIONER (Air to air heat pump type)**

**(OUTDOOR UNIT)  
SCM452HENG-L**

**(INDOOR UNIT)  
SKM222HENG-L  
SKM252HENG-L  
SKM282HENG-L  
SKM322HENG-L  
SKM402HENG-L**

## CONTENTS

<b>5.1 GENERAL INFORMATION .....</b>	<b>181</b>
<b>5.1.1 Specific features .....</b>	<b>181</b>
<b>5.1.2 How to read the model name .....</b>	<b>181</b>
<b>5.2 SELECTION DATA .....</b>	<b>182</b>
<b>5.2.1 Specifications .....</b>	<b>182</b>
<b>5.2.2 Range of usage &amp; limitations .....</b>	<b>186</b>
<b>5.2.3 Exterior dimensions .....</b>	<b>187</b>
<b>5.2.4 Piping system .....</b>	<b>189</b>
<b>5.3 ELECTRICAL DATA .....</b>	<b>190</b>
<b>5.3.1 Electrical wiring .....</b>	<b>190</b>
<b>5.4 OUTLINE OF OPERATION CONTROL BY MICROCOMPUTER .....</b>	<b>192</b>
<b>5.5 APPLICATION DATA .....</b>	<b>202</b>
<b>5.5.1 Installation of indoor unit.....</b>	<b>203</b>
<b>5.5.2 Installation of remote controller .....</b>	<b>205</b>
<b>5.5.3 Installation of outdoor unit .....</b>	<b>206</b>
<b>5.5.4 Electrical wiring .....</b>	<b>207</b>
<b>5.5.5 Refrigerant piping .....</b>	<b>208</b>
<b>5.5.6 Test run and handling instruction .....</b>	<b>210</b>
<b>5.6 MAINTENANCE DATA .....</b>	<b>211</b>
<b>5.6.1 Trouble shooting .....</b>	<b>211</b>
<b>5.6.2 Servicing .....</b>	<b>219</b>

## 5.1 GENERAL INFORMATION

### 5.1.1 Specific features

**(1) Equipped with an inverter scroll compressor.**

- Low noise. Low vibration and compact.

**(2) The long piping makes the location of the inside and units flexible.**

- No need for additional charge of refrigerant : 20 m
- Maximum piping length : 30 m

**(3) Connectable indoor capacity**

Number of connectable units : 1 to 2 units

Total of indoor units (class kW) : 6.5 kW

**(4) Indoor units are available with 5 capacities.**

5 capacities ..... 22, 25, 28, 32, 40

**(5) Inverter (Frequency converter) for multi-steps power control**

- Heating / Cooling

The rotational speed of a compressor is changed in step in relation to varying load, to interlock with the indoor and outdoor unit fans controlled to changes in frequency, thus controlling the power.

- Allowing quick heating/cooling operation during start-up period. Constant room temperature by fine-tuned control after the unit has stabilized.

**(6) Fuzzy control**

Fuzzy control calculates the amount of variation in the difference between the suction air temperature and the setting temperature in compliance with the fuzzy rules in order to control the air capacity and the inverter frequency.

**(7) Self diagnosis function**

We are constantly trying to do better service to our customers by installing such judges that show abnormality of operation as follows. (See Page 212)

### 5.1.2 How to read the model name

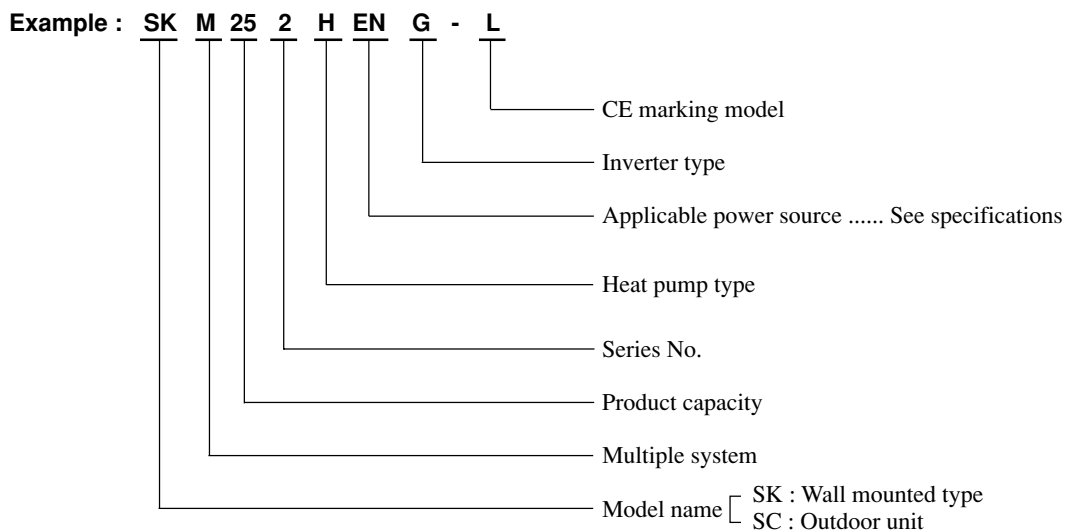

## 5.2 SELECTION DATA

### 5.2.1 Specifications

#### (1) Indoor unit

Models SKM222HENG-L, 252HENG-L, 282HENG-L, 322HENG-L, 402HENG-L

Item		Models		SKM222HENG-L	SKM252HENG-L	SKM282HENG-L	SKM322HENG-L	SKM402HENG-L
		W	dB (A)	2200	2500	2800	3200	4000
Cooling capacity		W		2200	2500	2800	3200	4000
Heating capacity		W		3200	3400	4000	4500	5400
Noise level <sup>(3)</sup>	Cooling	dB (A)		38		39	40	42
	Heating			39		40	41	42
Exterior dimensions Height × Width × Depth		mm		250 × 750 × 178		275 × 790 × 174		
Color				Ivory white				
Net weight		kg		7.5			8.0	
Air handling equipment Fan type & Q'ty				Tangential fan × 1				
Motor		W		17		18		
Air flow (at high)	Cooling	CMM		7.0		7.7	9.0	9.5
	Heating			7.5		9.1	10	10
Air filter, Q'ty				Polypropylene net × 2 (Washable)				
Operation switch				Wireless-Remote controller				
Room temperature control				M.C thermostat				
Pilot lamp				RUN (Green), TIMER (Yellow)				
Safety equipment				Frost protection, Serial error protection Fan motor error protection				
Refrigerant piping	O.D	Liquid line	mm (in)	φ 6.35 (1/4")				
		Gas line		φ 9.52 (3/8")		φ 12.7 (1/2")		
	Connecting method			Flare connecting				
	Attached length of piping			Liquid line : 0.4m Gas line : 0.35m				
	Insulation			Necessary (Both Liquid & Gas lines)				
Drain hose				Connectable				
Accessories (including)				Mounting kit				
Optional parts				—				
Outdoor units to be combined				SCM452HENG-L				

Notes (1) The data are measured at the following conditions.

Operation	Item	Indoor air temperature		Outdoor air temperature		Standards
		DB	WB	DB	WB	
Cooling		27°C	19°C	35°C	24°C	JIS C9612
Heating		20°C	—	7°C	6°C	JIS C9612

(2) Capacity indicated is the rated capacity with one unit operating under JIS standards conditions.

(3) Expressed in sound pressure level.

**(2) Outdoor unit  
Model SCM452HENG-L**

Item		Model	SCM452HENG-L
Cooling capacity		W	4500 (2000 ~ 5100)
Heating capacity		W	5600 (2200 ~ 6000)
Power source			1 Phase 220/240V 50Hz
Power consumption	Cooling	W	1820 (680 ~ 2050)
	Heating		1950 (650 ~ 2190)
Running current	Cooling	A	8.4/7.7
	Heating		9.0/8.2
Noise level <sup>(4)</sup>	Cooling	dB (A)	46
	Heating		48
Exterior dimensions Height × Width × Depth		mm	595 × 720 × 290
Color			Stucco white
Net weight		kg	36
Refrigerant equipment Compressor type & Q'ty			GR5490FD41 × 1
Motor		kW	1.2
Starting method			Direct start
Refrigerant control			Capillary tubes + Electric expansion valve
Refrigerant		kg	R22 1.3 (Pre-charged up to the piping length of 20m)
Refrigerant oil		ℓ	0.45 (BARREL FREEZE 32SAM)
Air handling equipment Fan type & Q'ty			Propeller fan × 2
Motor		W	24
Air flow (at high)		CMM	30
Shock & vibration absorber			Rubber (for compressor)
Safety equipment			Compressor overheat protection, Overcurrent protection High pressure protection, Serial signal error protection
Refrigerant piping	Size × Core × Number	mm (in)	Liquid line: φ 6.35 (1/4") × 2
			Gas line: φ 9.52 (3/8") × 2
	Connecting method	Flare connecting	
	Attached length piping	—	
Insulation			Necessary (Both Liquid & Gas lines)
Power source supply			Terminal block (Screw fixing type)
Conne- ction wiring	Size × Core number		1.5 mm <sup>2</sup> × 4 cores (Including earth cable)
	Connecting method		Terminal block (Screw fixing type)
Accessories (included)			Union : (φ 9.52 → φ 12.7) × 1 Installation sheet, Manual instruction
Indoor units to be combined			SKM22, 25, 28, 32, 40 type

Notes (1) The data are measured at the following conditions.

Operation	Item	Indoor air temperature		Outdoor air temperature		Standards
		DB	WB	DB	WB	
Cooling		27°C	19°C	35°C	24°C	JIS C9612
Heating		20°C	—	7°C	6°C	JIS C9612

- (2) The values for capacity and power consumption shown in a range ( ) indicate the minimum and maximum of the range.  
(3) If the piping length exceeds 20 m, additional charging is required. (20g/m)  
(4) Expressed in sound pressure level.

**(3) Operation data**

- The combinations of the indoor units is indicated by numbers. They are read as follows.  
(Example) SKM222HENG → 22 SKM402HENG → 40
- The capacity of the indoor units is shown by rooms. If this exceeds the maximum capacity of the outdoor unit, the demand capacity will be proportionally distributed.
- If units are to be combined, use the table below to make the proper selection.

**(a) Heating**

Indoor unit combination		Heating capacity (kW)					Power consumption (W)			Running current (A)
		Room heating capacity (kW)		Total capacity (kW)			Min.	Standard	Max.	Standard
		A room	B room	Min.	Standard	Max.				
1 room	22	3.2		1.4	3.2	3.9	400	1030	1330	4.73/4.34
	25	3.4		1.4	3.4	4.0	400	1170	1390	5.37/4.92
	28	4.0		1.4	4.0	4.7	400	1350	1680	6.20/5.68
	32	4.5		1.4	4.5	5.6	400	1580	2080	7.25/6.65
	40	5.4		1.4	5.4	6.0	400	2030	2300	9.32/8.54
2 room	22+22	2.8	2.8	2.2	5.6	6.0	650	1980	2190	9.09/8.33
	22+25	2.6	3.0	2.2	5.6	6.0	650	1950	2160	8.95/8.21
	22+28	2.5	3.1	2.2	5.6	6.0	650	1900	2100	8.72/8.00
	22+32	2.3	3.3	2.2	5.6	6.0	650	1850	2050	8.49/7.79
	22+40	2.0	3.6	2.2	5.6	6.0	650	1780	1970	8.17/7.49
	25+25	2.8	2.8	2.2	5.6	6.0	650	1950	2160	8.95/8.21
	25+28	2.6	3.0	2.2	5.6	6.0	650	1880	2080	8.63/7.91
	25+32	2.5	3.1	2.2	5.6	6.0	650	1830	2030	8.40/7.70
	25+40	2.2	3.4	2.2	5.6	6.0	650	1750	1940	8.03/7.37

## (b) Cooling

Indoor unit combination		Cooling capacity (kW)					Power consumption (W)			Running current (A)
		Room cooling capacity (kW)		Total capacity (kW)			Min.	Standard	Max.	Standard
		A room	B room	Min.	Standard	Max.				
1 room	22	2.2		1.1	2.2	2.5	350	750	900	3.44/3.16
	25	2.5		1.1	2.5	2.8	350	900	1040	4.13/3.79
	28	2.8		1.1	2.8	3.0	350	1040	1150	4.78/4.38
	32	3.2		1.1	3.2	3.5	350	1200	1360	5.51/5.05
	40	4.0		1.1	4.0	4.5	350	1580	1850	7.25/6.65
2 room	22+22	2.2	2.2	2.0	4.4	4.7	680	1750	1950	8.03/7.37
	22+25	2.1	2.4	2.0	4.5	4.8	680	1820	2020	8.36/7.66
	22+28	2.0	2.6	2.0	4.6	4.9	680	1830	2030	8.40/7.70
	22+32	1.9	2.8	2.0	4.7	5.0	680	1840	2040	8.45/7.74
	22+40	1.7	3.1	2.0	4.8	5.1	680	1850	2050	8.49/7.79
	25+25	2.25	2.25	2.0	4.5	4.8	680	1820	2020	8.36/7.66
	25+28	2.2	2.4	2.0	4.6	4.9	680	1830	2030	8.40/7.70
	25+32	2.1	2.6	2.0	4.7	5.0	680	1840	2040	8.45/7.74
	25+40	1.8	3.0	2.0	4.8	5.1	680	1850	2050	8.49/7.79

## 5.2.2 Range of usage & limitations

### (1) Inlet air temperature

#### (a) Cooling operation

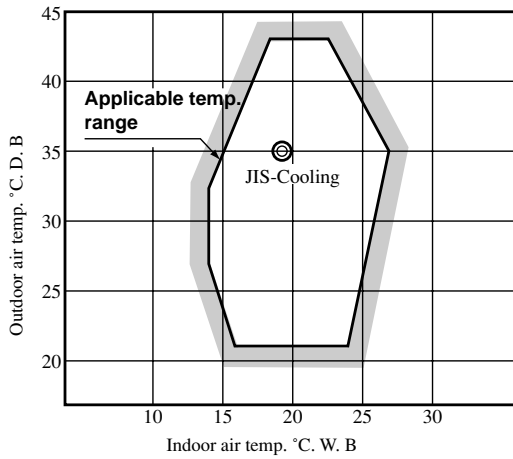

Note: The chart is result from the continuous operation under constant air temperature conditions, however, excludes the initial pull-down stage.

#### (b) Heating operation

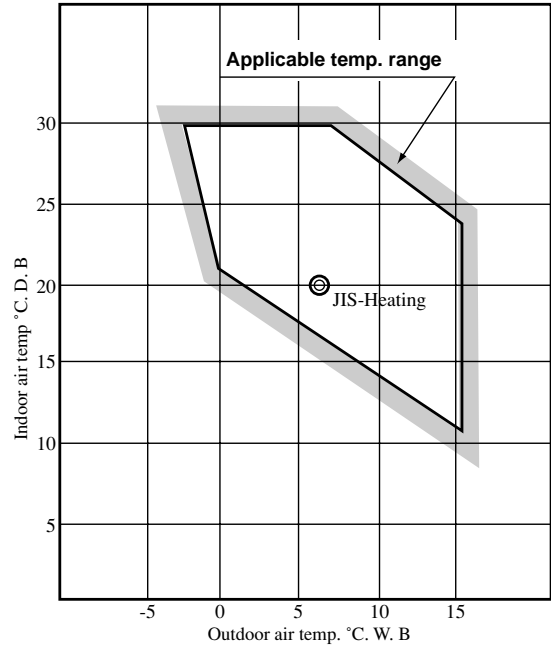

Note: The chart is result from the continuous operation under constant air temperature conditions, however, excludes the initial pull-down stage and any possible defrost cycles.

### (2) Total one way piping length and vertical height difference.

The maximum permissible length of the refrigerant pipes for the outdoor units, and the maximum permissible height difference for the outdoor units are as shown below.

Length for one indoor unit		Under 25m
Total length for all rooms		Under 30m
Height difference	Lower installation spot of the indoor unit A	Under 15m
	Upper installation spot of the indoor unit B	Under 10m
	Maximum height difference of the indoor units C	Under 10m
Length of chargeless refrigerant pipe		20m

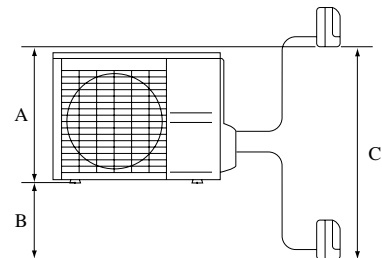

### (3) Indoor units that can be used in combination

Item	Models	SCM452HENG-L
Number of connected units		2 units
Total of indoor Units (class kW)		6.5 kW



### 5.2.3 Exterior dimensions

#### (1) Indoor unit

Models SKM222HENG-L, 252HENG-L

Unit: mm

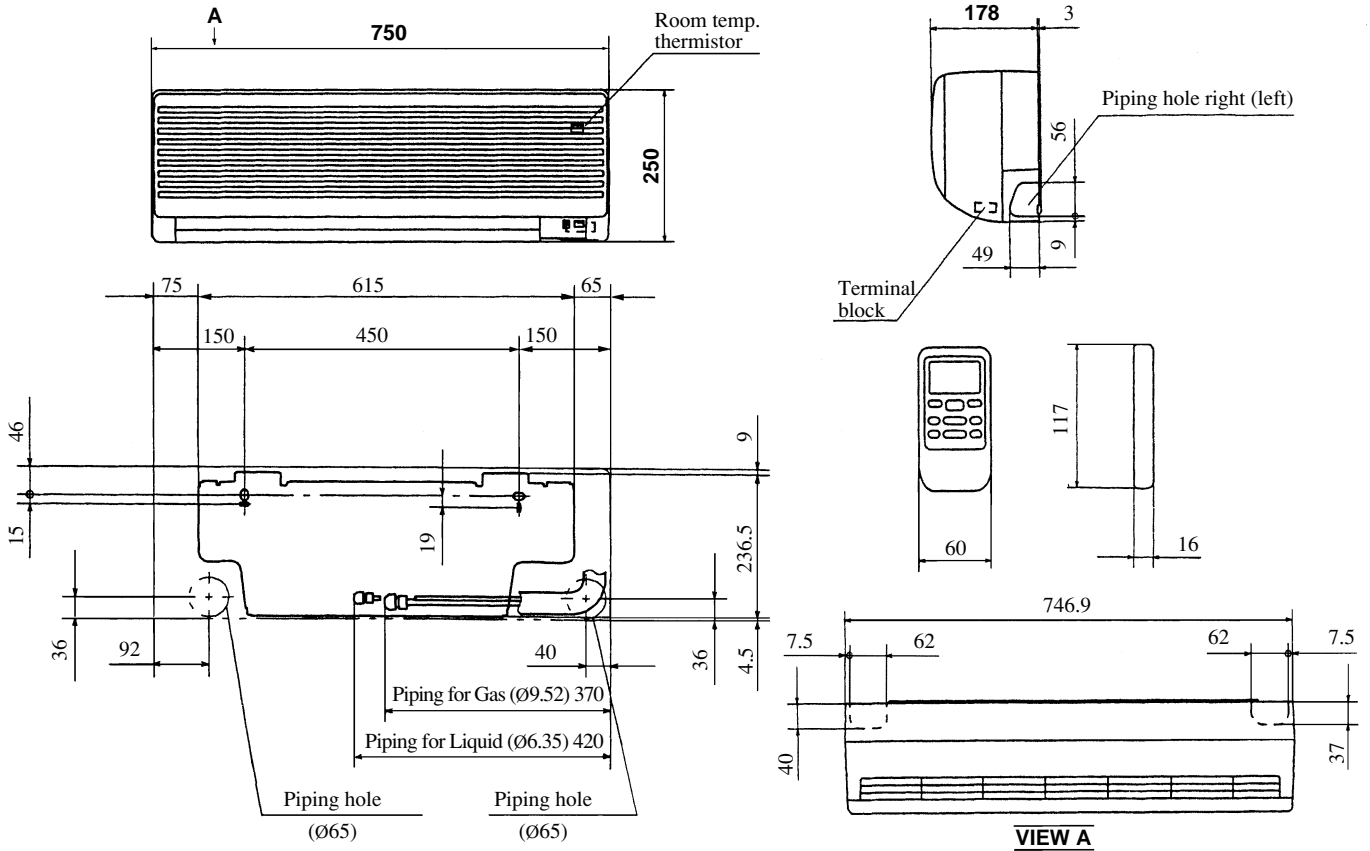

Model SKM282HENG-L

Unit: mm

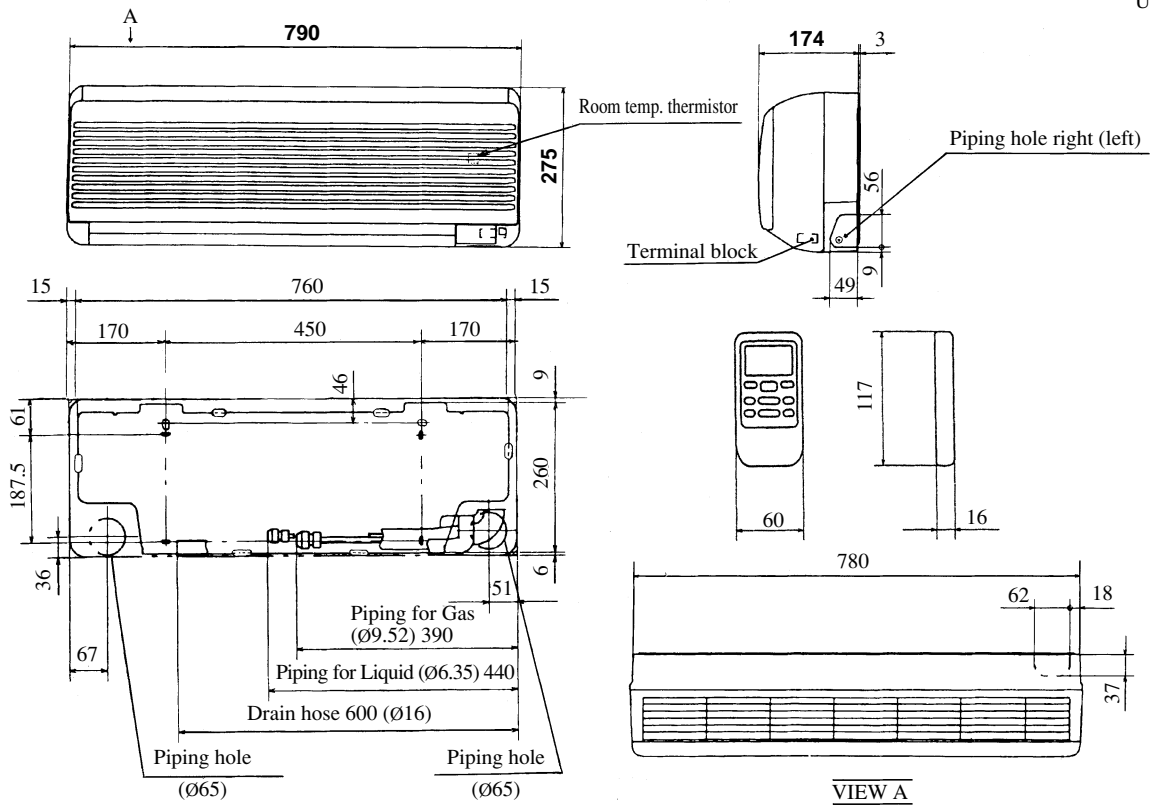

Models SKM322HENG-L, 402HENG-L

Unit: mm

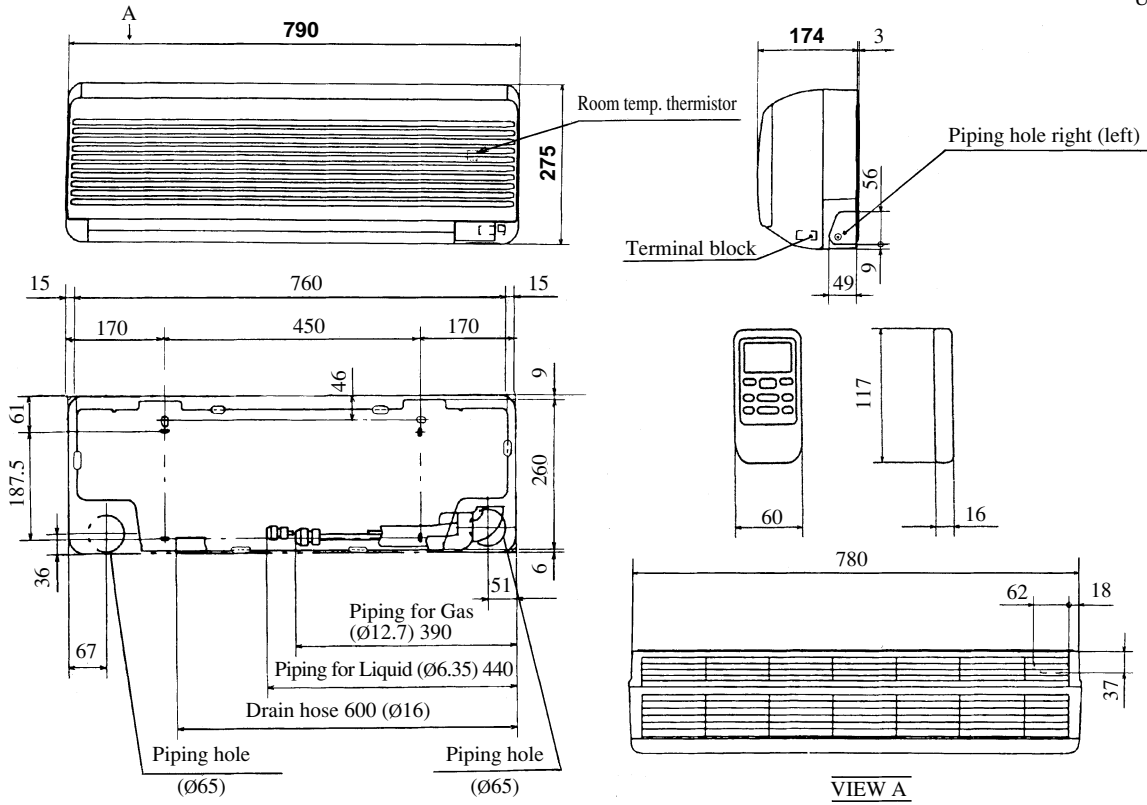

(2) Outdoor unit  
Model SCM452HENG-L

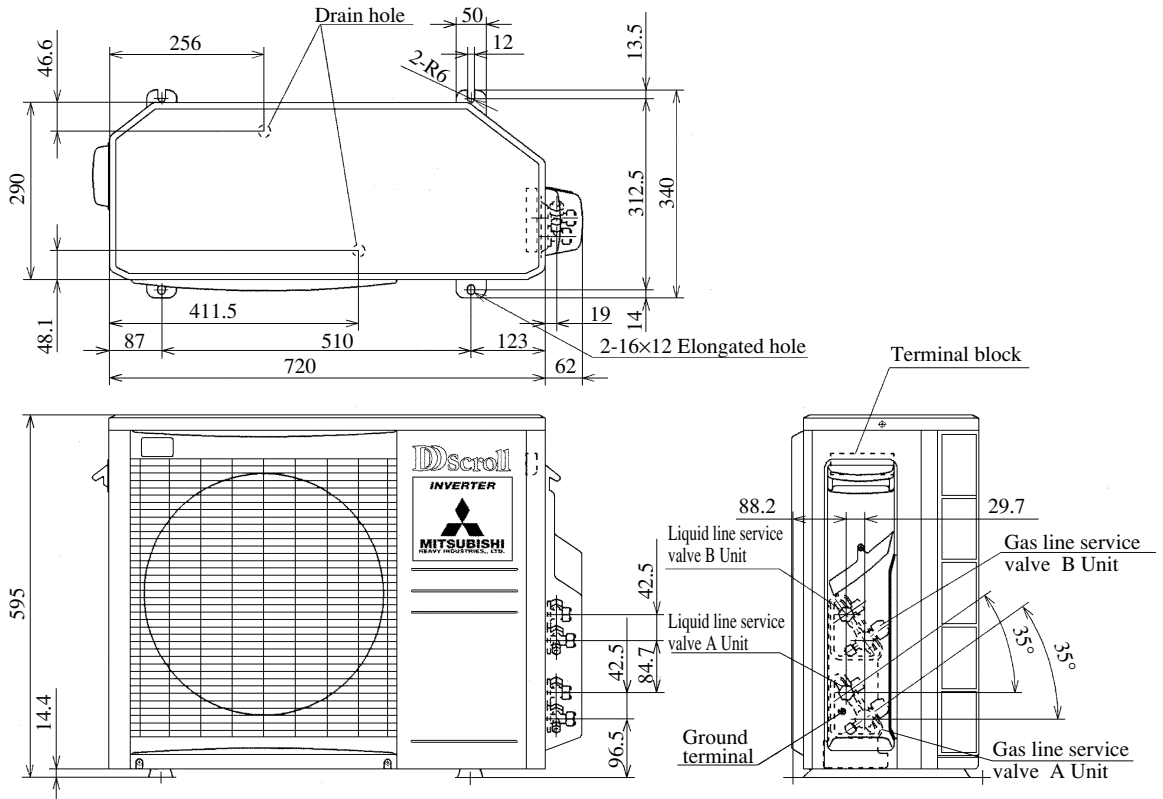

### 5.2.4 Piping system

Model SCM452HENG-L

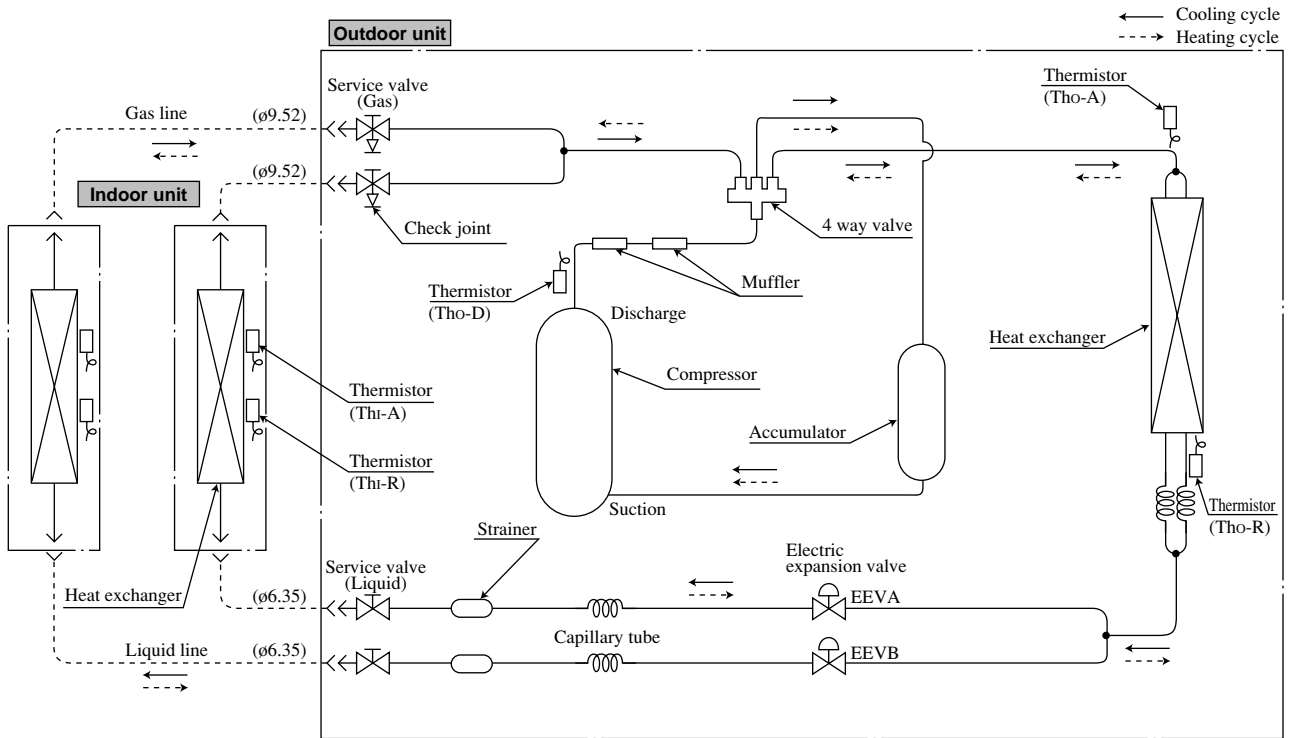

## 5.3 ELECTRICAL DATA

### Meaning of marks

#### • Outdoor Unit

Symbol	Parts name	Symbol	Parts name
CM	Compressor motor	Tho-A	Thermistor (outdoor air temp.)
FM <sub>o</sub>	Fan motor	Tho-R	Thermistor (outdoor H.X temp.)
L	Reactor	Tho-D	Thermistor (comp. dome temp.)
DS	Diode stack	LED2	Warning lamp (Red)
EEVA, B	Electric expansion valve	LED1, 3	Serial signal lamp (Green)
20S	4 way valve (coil)		

#### • Indoor Unit

Symbol	Parts name	Symbol	Parts name
FM <sub>i</sub>	Fan motor	Q	Fan motor control triac
CF <sub>i</sub>	Capacitor (for FM <sub>i</sub> )	F	Fuse
SM	Flap motor	Thi-A	Thermistor (Room temp.)
TR	Transformer	Thi-R	Thermistor (Indoor H. X temp.)
ZNR	Varistor		

### 5.3.1 Electrical wiring

#### (1) Indoor unit

Models SKM222HENG-L, 252HENG-L, 282HENG-L, 322HENG-L, 402HENG-L

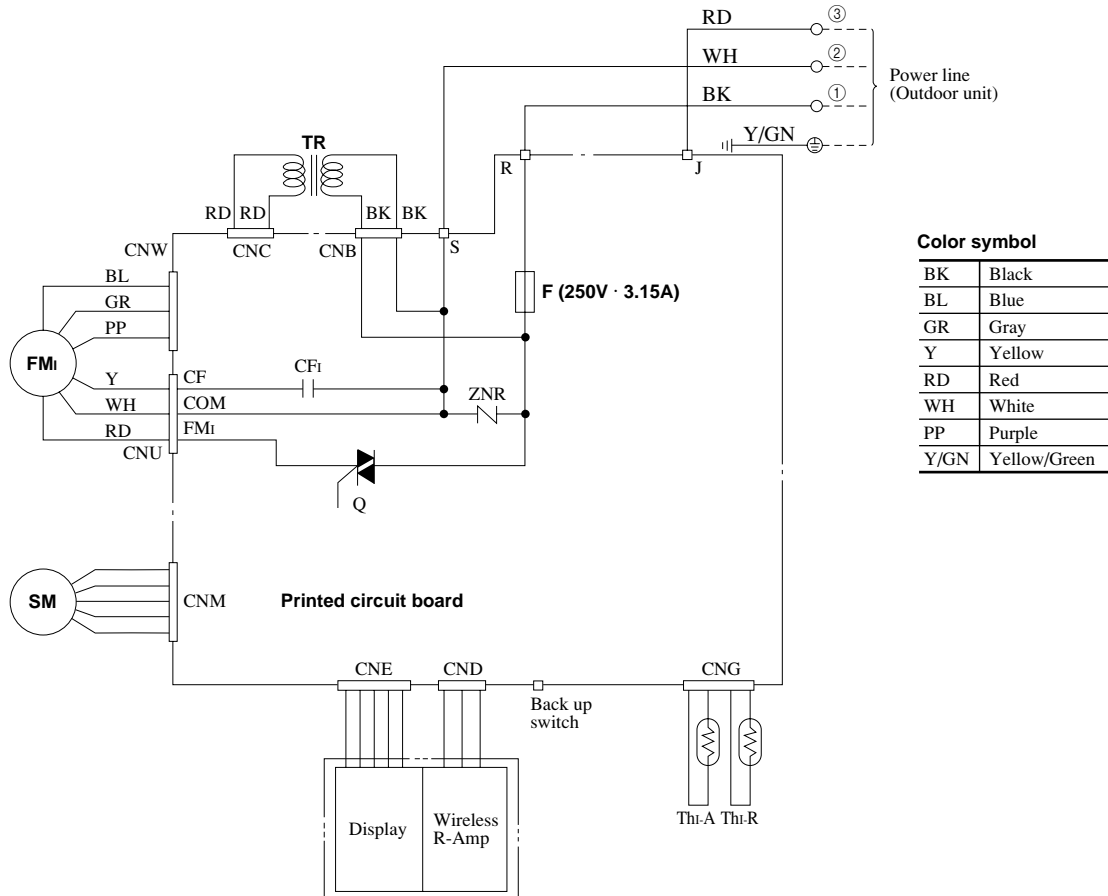

(2) Outdoor unit  
Model SCM452HENG-L

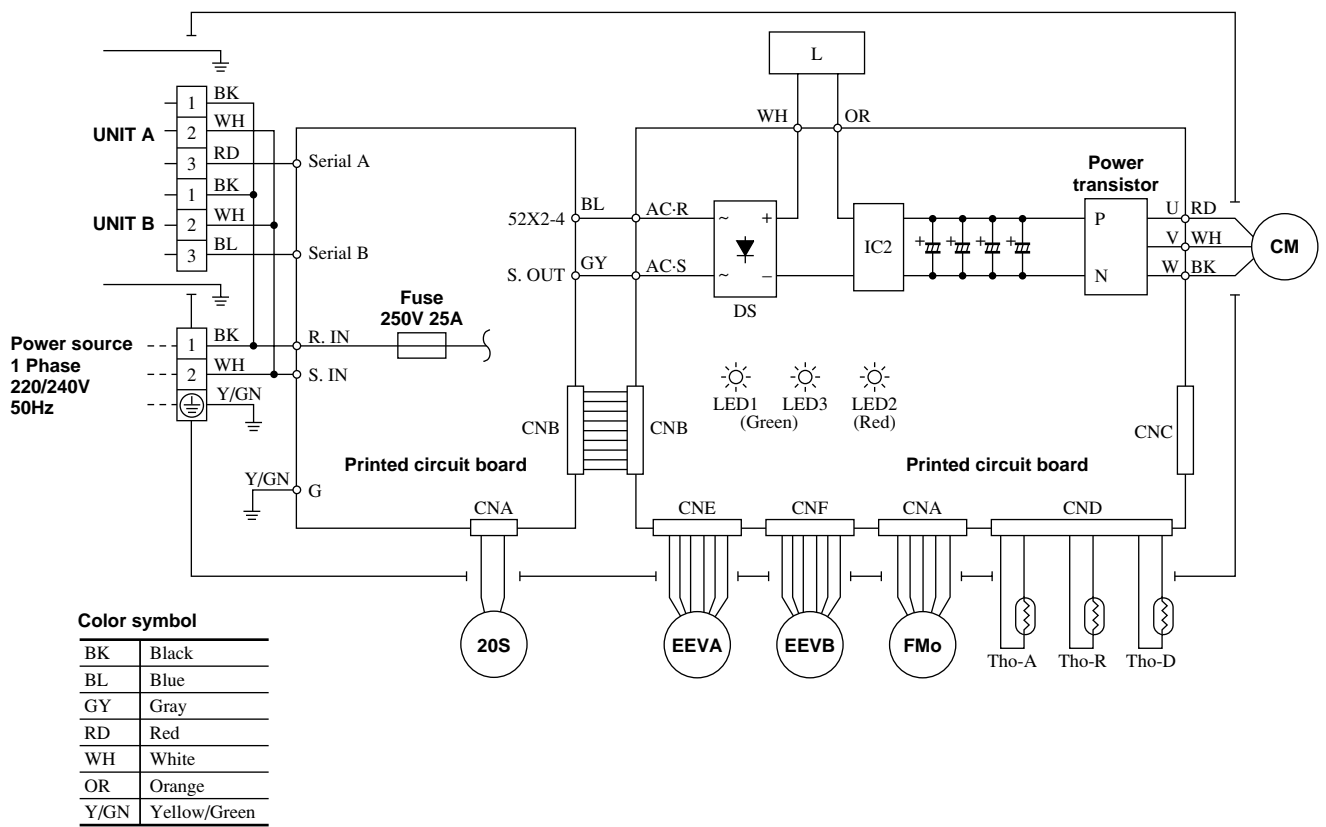

# 5.4 OUTLINE OF OPERATION CONTROL BY MICROCOMPUTER

## (1) Remote Control Switch

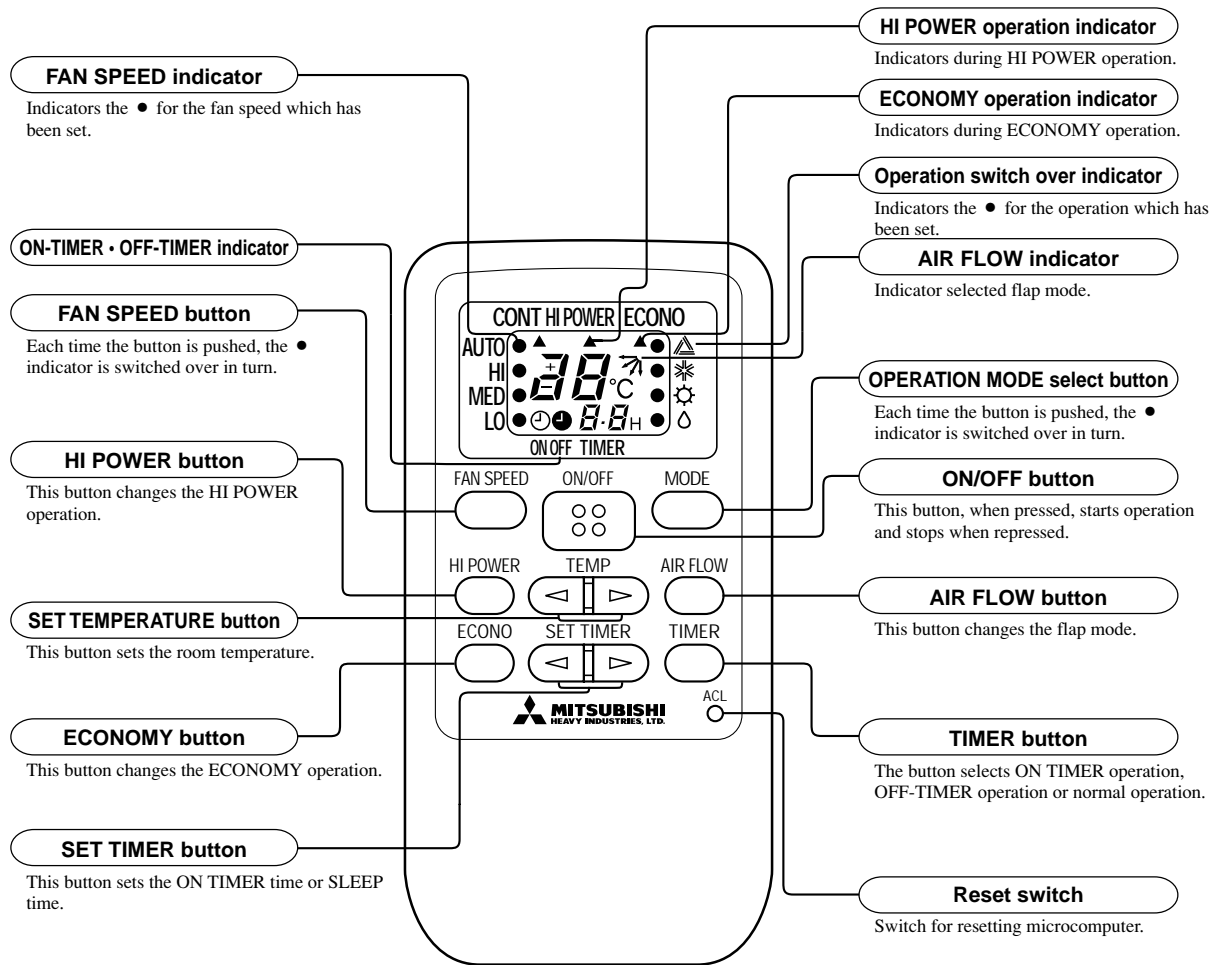

- Above figure shows all indications for the purpose of explanation, but practically only the pertinent parts are indicated.

Heat pump model : [ ▲ (AUTO) · ❄ (Cool) · ☀ (Heat) · ◊ (Dry) ]  
 Cooling only model : [ ▲ (AUTO) · ❄ (Cool) · ⚙ (Fan) · ◊ (Dry) ]

## (2) Indoor unit indicator

Models SKM222, 252type

Models SKM282, 322, 402type

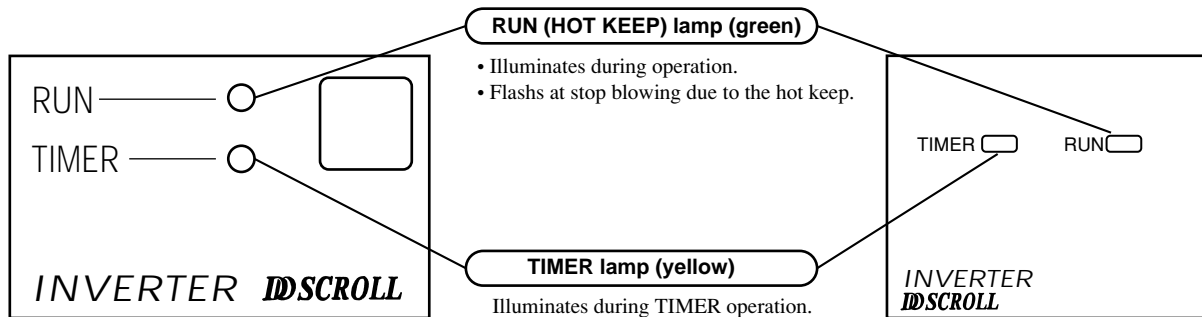

**(3) Back-up switch**

When the remote controller become weak, or if the remote controller is lost or malfunctioning, this switch may be used to turn the unit on and off.

**(a) Operation**

Push the switch once to place the unit in the automatic mode. Push it once more to turn the unit off.

**(b) Detail of operation**

Operation starts in the same way as the previous operation.

**Models SKM222, 252 type**

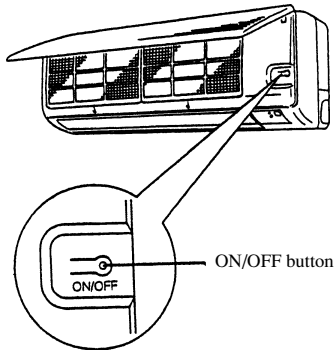

**Models SKM282, 322, 402 type**

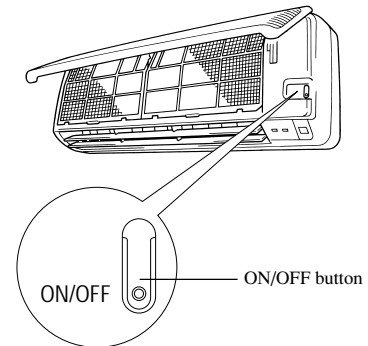

**(4) Flap control**

Control the flap by AIRFLOW button on the wireless remote control.

**(a) Natural flow (AUTO)**

The flap will be automatically set to the angle of air flow best to operation.

**1) Starting time of operation**

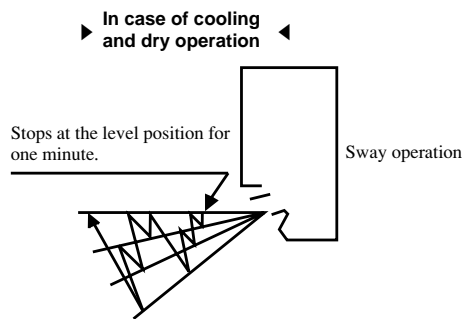

• The flap operation as shown above will be repeated.

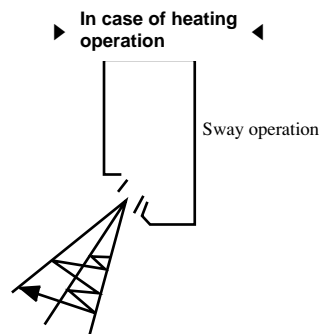

• The flap operation as shown above will be repeated.

**2) When not operating**

The flap returns to the position of air flow directly below, when operation has stopped.

**(b) Memory flap (Only case of SKM282, 322, 402 type)**

While the flap is operating if the AIRFLOW button is pushed once, it stops swinging at an angle.

As this angle is memorized in the microcomputer, the flap will be automatically set to the angle when next operation is started.

◆ Recommendable stopping angle of the flap

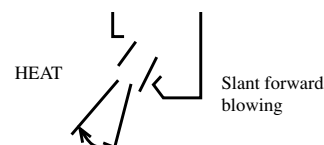
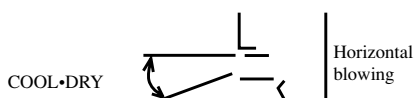

**(c) Swing flap**

Flap moves in upward and downward directions continuously.

**(5) Comfort timer setting**

If the timer is set at ON when the operation select switch is set at the cooling or heating, or the cooling or heating in auto mode operation is selected, the comfort timer starts and determines the starting time of next operation based on the initial value of 15 minutes and the relationship between the room temperature at the setting time (temperature of room temperature thermistor) and the setting temperature. (Max. 60 minutes)

Operation mode	Operation start time correction value (Min.)		
	At cooling	3 < Room temp. – Setting temp.	1 < Room temp. – Setting temp. ≤3
+5		No change	-5
At heating	3 < Setting temp. – Room temp.	2 < Setting temp. – Room temp. ≤3	Setting temp. – Room temp. ≤2
	+5	No change	-5

- Notes (1) At 5 minutes before the timer ON time, operation starts regardless of the temperature of the room temperature thermistor (Thi-A).  
 (2) This function does not actuate when the operation select switch is set at the dehumidifying as well as the dehumidifying in the auto mode. However, the operation of item (1) above is performed during the dehumidifying in the auto mode.  
 (3) During the pleasant reservation operation, both the operation lamp and timer lamp illuminate and the timer lamp goes off after expiration of the timer, ON setting time.

**(Example) Heating**

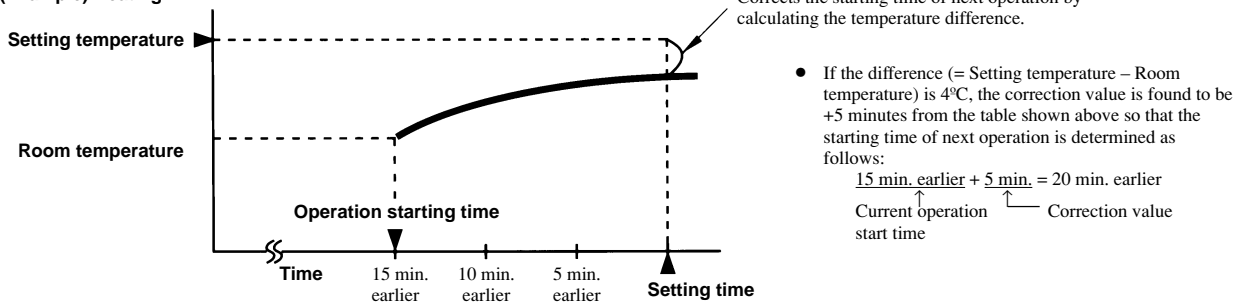

**(6) Cooling operation**

**(a) Summary**

**1) Capacity control**

Model	SCM452HENG-L	SCM452CENG-L
Capacity	2.0 ~ 5.1 kW	2.0 ~ 5.1 kW

Capacity control is within the range shown above. If demand capacity of the indoor units exceeds the maximum capacity of the outdoor unit, the demand capacity will be proportionally distributed.

**2) Outdoor unit speed control (28 ~ 120 rps)**

Indoor unit instruction total speed value	Decision speed
28 rps or less	28 rps
More than 28 rps, but 120 rps or less	28 to 120 rps
More than 120 rps	120 rps

Note (1) The indoor unit instruction total speed value is the total of the values from each unit in item (b).

**(b) Mode switching**

Within the selected mode, the unit operates using the values shown below which were obtained by multiplying a conversion coefficient to the indoor unit instruction speed.

(rps)

Model (Indoor) / Operation Mode	22	25	28	32	40
Automatic	28 ~ 58	28 ~ 68	28 ~ 88	28 ~ 96	28 ~ 110
High	28 ~ 58	28 ~ 68	28 ~ 88	28 ~ 96	28 ~ 118
Medium	28 ~ 44	28 ~ 50	28 ~ 60	28 ~ 70	28 ~ 100
Low	28 ~ 30	28 ~ 32	28 ~ 30	28 ~ 34	28 ~ 40
Hi power	58	68	86	96	108
Econo	28 ~ 34	28 ~ 36	28 ~ 50	28 ~ 40	28 ~ 50



(c) Operation of Major Functional Components in Cooling Mode

Functional components \ Operation		Cooling	Thermostat OFF (All indoor units)	Thermostat OFF (Some of indoor units)	Fan, stop, abnormal stop (Some of indoor units)	Failure (Outdoor Unit)
Instruction speed		See preceding table	0 (All indoor units)	0 (Thermostat off units)	0 (Fan, stop, abnormal stop units)	0 (All units)
Indoor unit fan	Fixed	According to mode switching				
	Automatic	According to instruction speed	According to mode switching	First speed or low		
Outdoor unit fan		According to outdoor unit speed	OFF	According to outdoor unit speed		OFF
Electronic expansion valve		According to decision speed	According to stop mode	All closed (Thermostat off units)	All closed (Fan, stop, abnormal stop units)	According to stop mode
Compressor		ON	OFF	ON	ON	OFF

(7) Heating Operation

(a) Summary

1) Capacity control

Model	SCM452HENG-L
Capacity	2.2 ~ 6.0 kW

Capacity control is within the range shown above. If demand capacity of the indoor units exceeds the maximum capacity of the outdoor unit, the demand capacity will be proportionally distributed.

2) Outdoor unit speed control (28 ~ 134 rps)

Indoor unit instruction total speed value	Decision speed
28 rps or less	28 rps
More than 28 rps, but 134 rps or less	28 to 134 rps
More than 140 rps	134 rps

Note (1) The indoor unit instruction total speed value is the total of the values from each unit in item (b).

(b) Mode switching

Within the selected mode, the unit operates using the values shown below which were obtained by multiplying a conversion coefficient to the indoor unit instruction speed.

(rps)

Model (Indoor) \ Operation Mode	22	25	28	32	40
Automatic	28 ~ 74	28 ~ 80	28 ~ 120	28 ~ 126	28 ~ 134
High	28 ~ 74	28 ~ 80	28 ~ 120	28 ~ 126	28 ~ 134
Medium	28 ~ 50	28 ~ 58	28 ~ 86	28 ~ 92	28 ~ 126
Low	28 ~ 34	28 ~ 36	28 ~ 46	28 ~ 46	28 ~ 54
Hi power	76	82	120	120	126
Econo	28 ~ 42	28 ~ 44	28 ~ 60	28 ~ 54	28 ~ 64

(c) Operation of Major Functional Components in Heating Mode

Functional components \ Operation		Heating	Thermostat OFF (All indoor units)	Thermostat OFF (Some of indoor units)	Fan, stop, abnormal stop (Some of indoor units)	Failure (Outdoor Unit)
Instruction speed		See preceding table	0 (All indoor units)	0 (Thermostat off units)	0 (Fan, stop, abnormal stop units)	0 (All units)
Indoor unit fan	Fixed	According to mode switching	Hot Keep	According to mode switching		Hot Keep
	Automatic	According to instruction speed	Hot Keep	According to instruction speed		Hot Keep
Outdoor unit fan		According to outdoor unit speed	OFF	According to outdoor unit speed		OFF
Electronic expansion valve		According to decision speed	According to stop mode	After 4 minutes all closed: 58 pulse (Thermostat off units)	58 Pulse (Fan, stop, abnormal stop units)	According to stop mode
Compressor		ON	OFF	ON	ON	OFF

**(d) Hot keep operation**

If the hot keep operation is selected during the heating operation, the indoor fan is controlled based on the temperature of the indoor unit heat exchanger (detected with Th1-R, indoor unit heat exchanger thermistor) to prevent blowing of cool wind.

- **Normal mode (Normal heating operation, operation after HI POWER completion)**

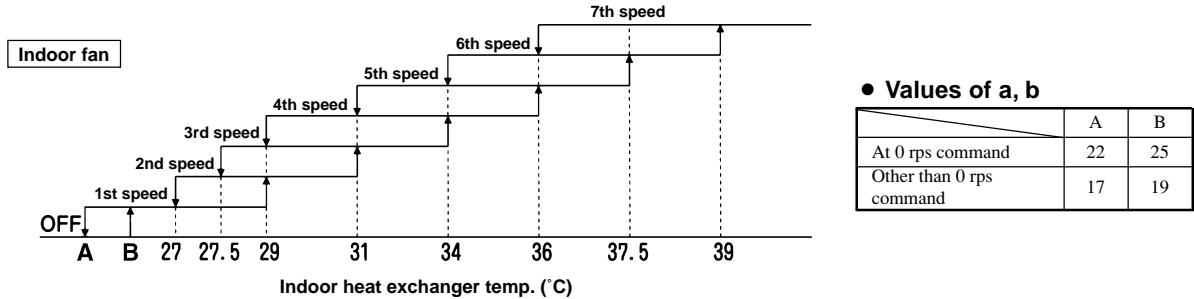

Note (1) Refer to the table shown above right for the values A and B.

- **Hot keep M mode [During HI POWER operation (for 15 min.)]**

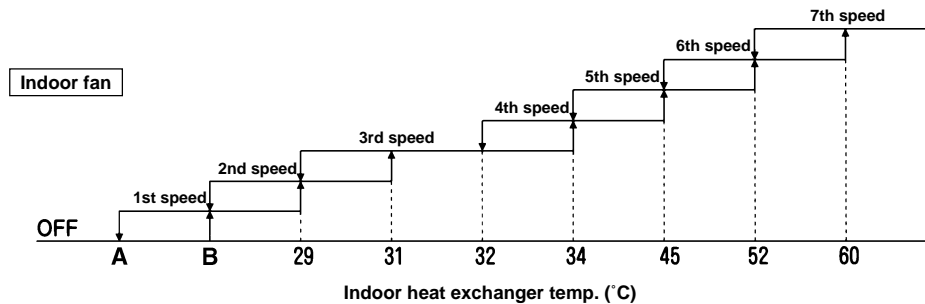

**(e) Defrosting**

(i) When the following conditions are met, the defrosting operation will start.

**1) During normal operation**

- When 40 minutes has passed since the start of heating or 40 minutes after the last defrosting (based on cumulative operation time of compressor).
- When the outdoor heat exchanger thermistor (Tho-R) temperature is  $-2\text{ }^{\circ}\text{C}$  or less for 3 continuous minutes after 37 minutes have passed.
- Outdoor temperature thermistor (Tho-A) – outdoor heat exchanger thermistor (Tho-R) temperature  $\geq 0.44 \times$  outdoor temperature thermistor (Tho-A) temperature + A  $^{\circ}\text{C}$  or more.  
A = Outdoor temperature  $\geq -2\text{ }^{\circ}\text{C}$ : 4, outdoor temperature  $< -2\text{ }^{\circ}\text{C}$ : 6.
- When the compressor is operating.

▷ Or, during heating, defrosting will start when the decision speed counts zero (0) rps for 10 times or more and all conditions in a), b) and d) have been satisfied.

**2) During defrosting acceleration**

- When 40 minutes has passed since the last defrosting (based on cumulative operation time of compressor).
  - When the compressor is operating.
- ▷ Or, during heating, defrosting will start when the decision speed counts zero (0) rps for 10 times or more and all conditions in a) and b) have been satisfied.

Note (1) Defrosting acceleration is when the finishing of the previous defrosting is according to the defrosting conditions of the 10 minutes that have passed.

3) Operation of function component in defrosting

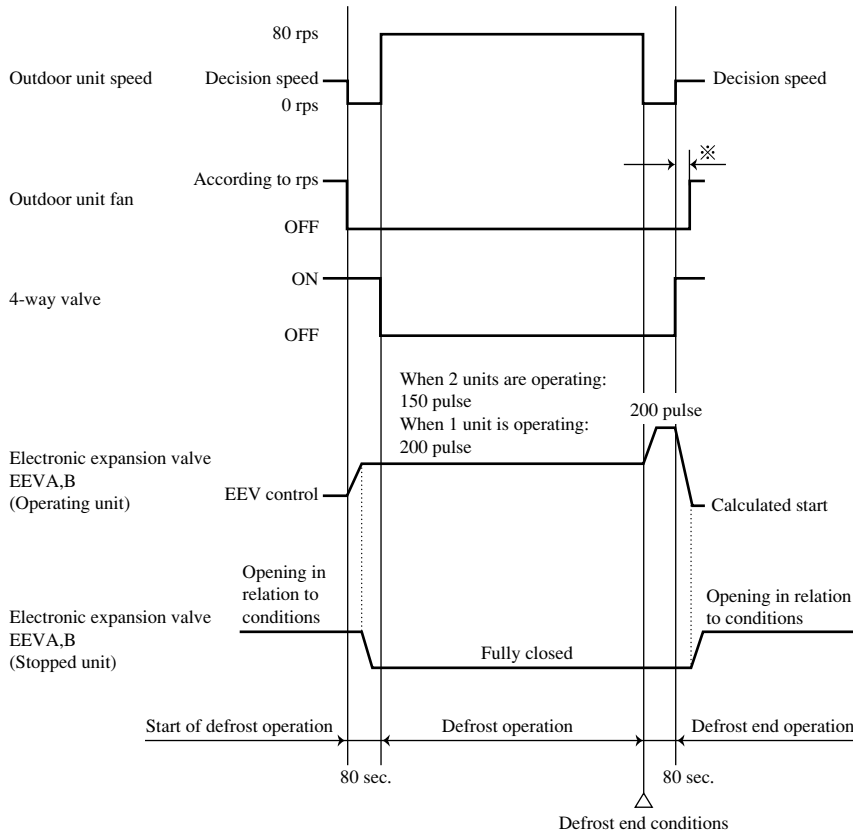

- Notes (1) Indoor unit fan is in response to Hot Keep.
- (2) ※ Outdoor unit fan starts 6 seconds after the start of the compressor.

4) Conditions for finishing defrosting

When any of the following conditions is met, the defrosting finishing operation will start.

- ① When the temperature of the outdoor heat exchanger thermistor (Tho-R) is 9 °C or more.
- ② When 10 minutes has passed after the start of defrosting.

(8) Determining the operating mode

The cooling and heating operating modes are the remote control switch mode that have been previously determined.

If a mode differing from these is selected after this, the selected mode will appear in the display of the remote control, but only the fan will operate.

Example	First operation			Second operation			Notes
	Selected Mode	Remote Control Display	Operation	Selected Mode	Remote Control Display	Operation	
1	Cooling	Cooling	Cooling	Heating	Heating	Fan (1)	• Different mode is only fan operation.
2	Heating	Heating	Heating	Cooling	Cooling	Fan	

Note (1) If the display shows heating and the operation is fan, Hot Keep will operate.

Example of operating pattern

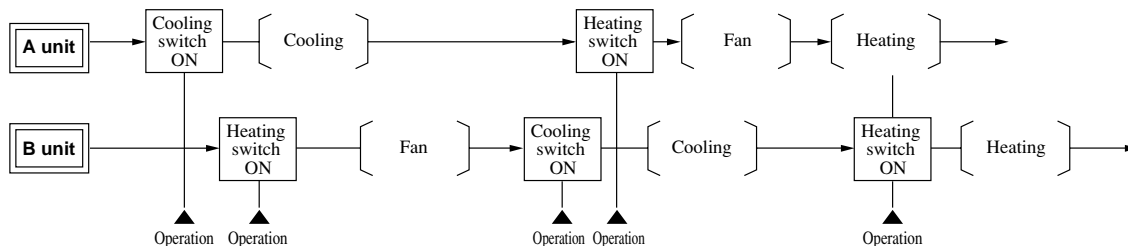

Note (1) [ ] indicates current operation.

**(9) Control and protection functions**

**(a) Start of protection for compressor**

When the decision speed becomes a speed other than 0 rps and when the compressor is starting operation, an inverter decision speed of 40 rps or less indicates four-way valve switching protection and a speed of 40 rps or more indicates that protection of the compressor has started.

**1) Start of protection for compressor**

- a) After the compressor has started, the speed of the outdoor unit will reach a maximum value of 56 rps for 1 minute and 45 seconds.
- b) During this time, if the decision speed exceeds 56 rps, operation will be at 56 rps; if it is 56 rps or less, operation will be at the decision speed or operation with four-way valve switching protection.
- c) The outdoor unit fan speed operates according to outdoor unit speed.
- d) If restarting after a thermostat stop, the protection function for the outdoor unit operates and when restarting after the inverter stop, compressor protection is not started.
- e) During the start of protection, current safe and compressor overheat have priority.

**2) Four-way valve switching protection**

Four-way valve switching protection is performed so that four-way valve switching will be performed smoothly.

- a) When the decision speed starts at less than 40 rps, it forces the decision speed to operate at 40 rps for 30 seconds.
- b) After 30 seconds, the speed of the outdoor unit is transferred to the decision speed.
- c) This function applies to all units starting from an outdoor unit speed of 0 rps.
- d) Current safe and compressor overheat protection are enabled even when this function is in operation.

**(b) Heating overload protection control**

During heating operation, if the outdoor unit is operating at a speed at 28 rps or more and the outdoor temperature is 12 °C or more for 30 continuous seconds, current safe control is performed.

Operation is restored when the outdoor temperature is 10 °C or less.

**(c) Cooling overload protection control**

During cooling operation, if the outdoor unit is operating at a speed at 28 rps or more and the outdoor temperature is 39 °C or more for 3 continuous minutes, current safe control is performed by turning the outdoor fan dial up by 1 unit. Operation is restored when the outdoor temperature is 38 °C or less.

**(d) Heating thermostat OFF control**

When there is a heating operation being performed for one room while a heating thermostat OFF is being performed in another room, the following controls are performed to prevent overheating.

**1) This control is performed when all of the following conditions have been satisfied.**

- a) Compressor: During operation (determined speed 28 rps or more)
- b) One room serial signal: Operating mode – heating, command speed: other than 0 rps.
- c) Other room serial signal: Operating mode – heating, command speed: 0 rps.

**2) Description of control**

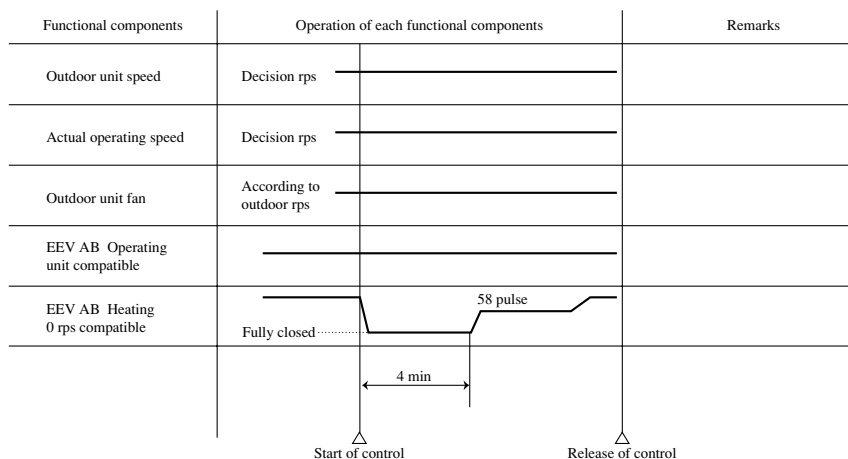

**(e) High pressure cut protection control**

The high pressure cut protection operates during heating operations when a “heating 0 rps” serial signal is received from one of the two operating indoor units.

① When only one of two operating units sends a “heating 0 rps” signal.

Functional components		Operation of each functional components	Remarks
Indoor unit instruction speed	A room		Instruction speed from indoor unit that has “heating 0 rps”.
	B room		Instruction speed for indoor unit that has “other than heating 0 rps”.
Actual operating speed			
Outdoor unit fan			
4-way valve			
EEVA			Corresponding expansion valve for unit with serial signal that has “heating 0 rps”.
EEVB			Corresponding expansion valve for unit with serial signal that has “other than heating 0 rps”.

② When decision speed becomes 0 rps during high pressure cut protection control

Functional components		Operation of each functional components	Remarks
Indoor unit instruction speed	A room		The sequence for 0 rps instruction shows one example.
	B room		
Actual operating speed			
Outdoor unit fan			
4-way valve			
EEVA			
EEVB			

**(f) Low Hz continuous operation protection control**

The following controls are performed to return oil to the compressor when the outdoor unit speed of 28 rps or more to 40 rps or less is continuously operated for 20 minutes.

- 1) The decision speed is forced to operate at 40 rps for 2 minutes.
- 2) The outdoor fan and electronic expansion valve are operated according to the outdoor unit speed.
- 3) If there is an instruction exceeding 40 rps during this forced 40 rps operation, this control ends and the operation follows that instruction.

**(g) Heating low temperature protection control**

The following controls are performed when the outdoor unit is in heating operation at a speed other than 0 rps and the outdoor temperature is 2 °C or less for 1 continuous minute.

- 1) The outdoor unit fan speed is forced to 5th speed.
- 2) This control is ended when the outdoor temperature reaches 4 °C or more.

**(h) Current safe control**

- 1) When converter in port current is detected at the current sensor (CT) and it exceeds the set amperage, the speed is reduced 2 rps. This is rechecked after one second and if it still exceeds the set amperage, the speed is reduced another 2 rps.
- 2) If the actual speed operated at 28 rps or less, the inverter is stopped. It is restarted after a 3 minute delay. However, if it is restarted repeatedly within an interval of 1 hour, it will not start on the fifth time.

**(i) Current cut**

This detects converter output current at the shunt resistor and if it exceeds the set value, the inverter is stopped. It is restarted after a 3 minute delay. However, if the current cut operates again when the actual speed is less than 20 rps, it will not start on the fourth time.

**(j) Compressor overheat protection**

The detection temperature of the compressor dome thermistor (Tho-D) is used to prevent oil deterioration and damage to the motor wire due to overheating of the compressor.

- 1) If Tho-D becomes  $\geq 125$  °C, the inverter is stopped. After the stop mode has been activated, the inverter will be restarted when Tho-D becomes  $< 95$  °C. However, if it is restarted repeatedly within an interval of 1 hour, it will not start on the third time.
- 2) When  $105$  °C  $\leq$  Tho-D  $< 125$  °C, the following outdoor unit speed controls are performed.

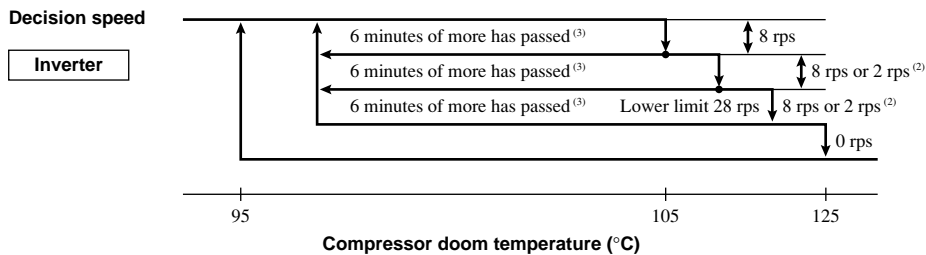

- Notes (1) If the temperature of the compressor dome is 105 °C or more and less than 125 °C, the outdoor unit speed is reduced by 8 rps.  
 (2) After 20 seconds, if the temperature of the compressor dome has decreased, it is lowered 2 rps. If the temperature has risen or is the same, it is lowered another 8 rps.  
 (3) If the temperature of the compressor dome is 95 °C or more and less than 105 °C, the speed of the outdoor unit is maintained. If operation is maintained at the same speed for 6 minutes or more or if the temperature is 95 °C or less, control is returned to normal operation.

**(k) Serial transmission abnormality protection**

If the compressor is operating with an outdoor speed other than 0 rps and a serial signal cannot be received from all indoor controls with outdoor controls having serial signals other than “stop - 0 rps” continuously for 1 minute and 55 seconds, the inverter is stopped.

After the inverter has been stopped, it will be restarted after the compressor start delay if a serial signal can be received again from the indoor control.

**(l) Compressor lock**

If the motor for the compressor does not turn a half a turn approximately 0.3 seconds after it has been started, it is determined that a compressor lock has occurred and the inverter is stopped.

**(m) Compressor dome thermistor broken wire protection control**

- 1) When the outdoor unit speed is other than 0 rps and after the compressor has started to operate, if after 10 minutes there is a compressor dome thermistor temperature 10-second interrupt signal (less than 7 °C), it is immediately placed in stop mode and restarted. (This detection is only performed once when the compressor is on.)
- 2) If an error continues for 4 times continuously, a permanent stop is made. (Restoration requires resetting the power supply.)

**(n) Outdoor unit failure**

This is a function for determining when there is trouble with the outdoor unit during air conditioning.

The inverter is stopped if any one of the following in item 1), 2) is satisfied. Once the unit is stopped by this function, it is not restarted.

- 1) When the input current is measured at 1 A or less for 3 continuous minutes or more.
- 2) If the outdoor unit sends a 0 rps signal to the indoor unit 3 times or more within 20 minutes of the power being turned on.

**(o) Stop mode (Decision speed is 0 rps, when the protection function for the outdoor controller is operating, when restarting due to operation change)**

Functional components	Operation	If stopping due to an indoor unit instruction and if permanent stop.		Operation of outdoor unit protection function, if restarting when recovering from thermostat stop and switching operations.	
		Cooling	Heating	Cooling	Heating
Outdoor unit speed	Decision rps 0				
Actual operating speed	Outdoor rps 0				
Outdoor unit fan	According to outdoor rps 0				
4-way valve	ON OFF				
E EVA	EEV control Fully closed				
E EVB	EEV control Fully closed				
		△ Stop instructions    △ All stop	△ Stop instructions    △ All stop	△ 0 rps instructions    △ Restart	△ Stop instructions    △ Restart

**(10) Regulation of outdoor air flow**

(a) The fan operates as follows according to the speed of the outdoor unit. (Except during defrost.)

Outdoor unit speed	Fuzzy auto when starting	Less than 80	80 or more and less than 100	100 or more and less than 120	120 or more
Outdoor fan speed	1st speed	2nd speed	3rd speed	4th speed	5th speed

(b) If the outdoor unit fan motor speed is 300 rpm or less for 30 seconds or more continuously, the compressor and outdoor unit fan are stopped.

## 5.5 APPLICATION DATA

### SAFETY PRECAUTIONS

- Please read these “Safety Precautions” first then accurately execute the installation work.
- Though the precautionary points indicated herein are divided under two headings, **⚠WARNING** and **⚠CAUTION**, those points which are related to the strong possibility of an installation done in error resulting in death or serious injury are listed in the **⚠WARNING** section. However, there is also a possibility of serious consequences in relationship to the points listed in the **⚠CAUTION** section as well. In either case, important safety related information is indicated, so by all means, properly observe all that is mentioned.
- After completing the installation, along with confirming that no abnormalities were seen from the operation tests, please explain operating methods as well as maintenance methods to the user (customer) of this equipment, based on the owner’s manual. Moreover, ask the customer to keep this sheet together with the owner’s manual.

#### **⚠WARNING**

- This system should be applied to places as households, residences and the like. Application to inferior environment such as engineering shop could cause equipment malfunction.
- Please entrust installation to either the company which sold you the equipment or to a professional contractor. Defects from improper installations can be the cause of water leakage, electric shocks and fires.
- Execute the installation accurately, based on following the installation manual. Again, improper installations can result in water leakage, electric shocks and fires.
- For installation, confirm that the installation site can sufficiently support heavy weight. When strength is insufficient, injury can result from a falling of the unit.
- For electrical work, please see that a licensed electrician executes the work while following the safety standards related to electrical equipment, and local regulations as well as the installation instructions, and that only exclusive use circuits are used.  
Insufficient power source circuit capacity and defective installment execution can be the cause of electric shocks and fires.
- Accurately connect wiring using the proper cable, and insure that the external force of the cable is not conducted to the terminal connection part, through properly securing it improper connection or securing can result in heat generation or fire.
- Take care that wiring does not rise upward, and accurately install the lid/service panel. It’s improper installation can also result in heat generation or fire.
- When setting up or moving the location of the air conditioner, do not mix air etc. or anything other than the designated refrigerant (R22) within the refrigeration cycle.  
Rupture and injury caused by abnormal high pressure can result from such mixing.
- Always use accessory parts and authorized parts for installation construction. Using parts not authorized by this company can result in water leakage, electric shock, fire and refrigerant leakage.
- Ventilate the work area when refrigerant leaks during the operation. **⚠**  
Coming in contact with fire, refrigerant could generate toxic gas.
- Confirm after the foundation construction work that refrigerant does not leak.  
If coming in contact with fire of a fan heater, a stove or movable cooking stove, etc., refrigerant leaking in the room could generate toxic gas.

#### **⚠CAUTION**

- Execute proper grounding. Do not connect the ground wire to a gas pipe, water pipe, lightning rod or a telephone ground wire. **⚡**  
Improper placement of ground wires can result in electric shock.
- The installation of an earth leakage breaker is necessary depending on the established location of the unit. No installing an earth leakage breaker may result in electric shock.
- Do not install the unit where there is a concern about leakage of combustible gas. **⊘**  
The rare event of leaked gas collecting around the unit could result in an outbreak of fire.
- For the drain pipe, follow the installation manual to insure that it allows proper drainage and thermally insulate it to prevent condensation. Inadequate plumbing can result in water leakage and water damage to interior items.



## 5.5.1 Installation of indoor unit

### (a) Caution for installation

- 1) The system should be applied to places as households, residences and the like.
- 2) The equipment shall be installed in accordance with national wiring regulations.
- 3) The connection to the fixed wiring of the mains supply must be made via a double pole isolating switch with a contact gap of at least 3mm in each pole.
- 4) When the outdoor unit has a possibility of being overturned or being displaced and fall from its original installation position, the outdoor unit should be fixed in its position by the use of anchor bolts or wires.

### (b) Installation of indoor unit

#### 1) Fixing of installation Board

- Find the inside wall structures (pillar, etc.) and secure the board after checking the horizontal level.

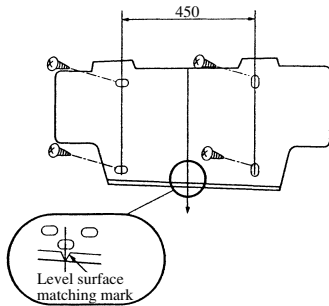

- Horizontal level adjustment of the board is conducted with four temporarily tightened screws.

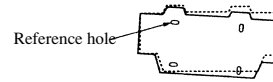

- Adjust so that the board will be horizontal with the reference hole in the center.

#### Installation space (Indoor Unit)

Models SKM222, 252 type

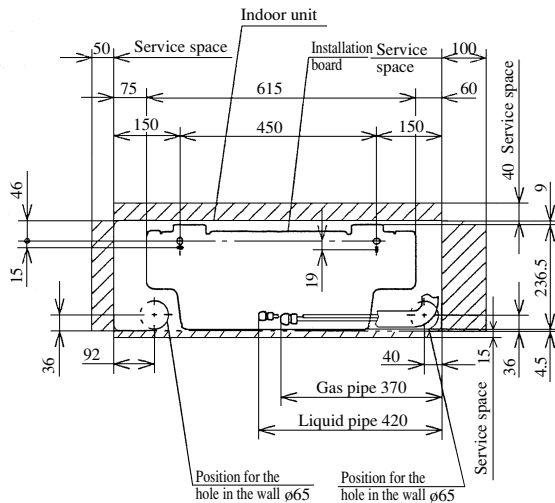

Models SKM282, 322,402 type

Unit: mm

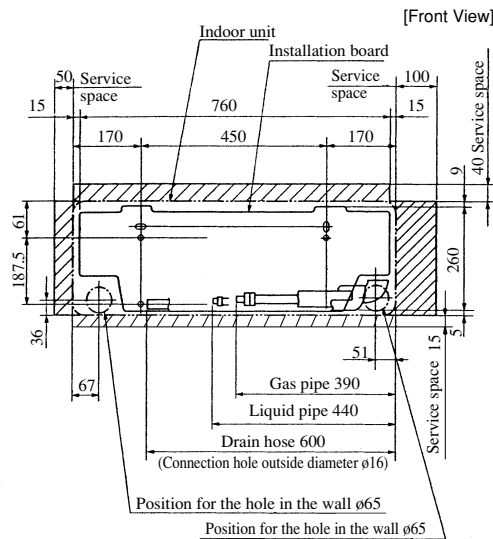

#### 2) Drilling of holes and fixture of sleeve (Option ports)

- The connecting wires may touch the metal inside the wall and cause danger so it is necessary to always use the sleeve.

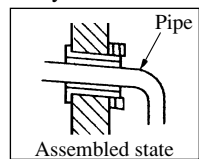
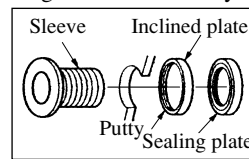
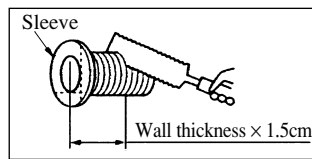
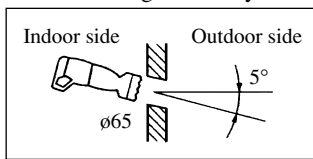

- Drill a hole with a 65 whole core drill.
- When the pipe is connected at the rear, cut off the lower and the right side portions of the sleeve collar (as shown by the broken line.)

**3) Mounting of interconnecting wires (Field wiring)**

- a) Remove the lid.
- b) Remove the terminal block cover.
- c) Connect the connection wire securely to the terminal block.

Use cables for interconnection wiring to avoid loosening of the wires.  
CENELEC code for cables Required field cables.

H05 RNR4G1.5 (Example)

H Harmonized cable type

05 300/500 volts

R Natural-and/or synth. rubber wire insulation

N Polychloroprene rubber conductors insulation

R Stranded core

4 Number of conductors

G One conductor of the cable is the earth conductor (yellow/green)

1.5 Section of copper wire (mm<sup>2</sup>)

- 1) Connect the connection wire securely to the terminal block. If the wire is not affixed completely, contact will be poor, and it is dangerous as the terminal block may heat up and catch fire.
- 2) Take care not to confuse the terminal numbers for indoor and outdoor connections.
- 3) Affix the connection wire using the wiring clamp.
- d) Attach the terminal block cover.
- e) Attach the lid.

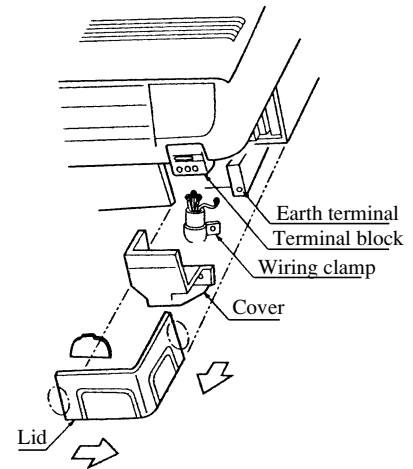

Removed by pressing in the section with the broken lines and pulling it towards the arrow.

**4) Shaping the pipe and drain hose**

[Shaping the pipe]

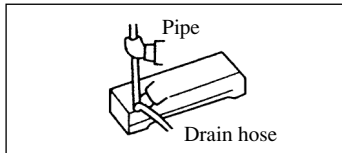

- Hold the bottom of the pipe and change its direction before stretching it and shaping it.

[Taping of the exterior]

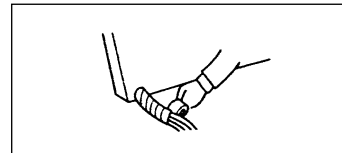

- Tape only the portion that runs through the wall. Always tape the crossover wires with the pipe.

**Cautions when piping from the left and the rear center of the unit**

[Top View]

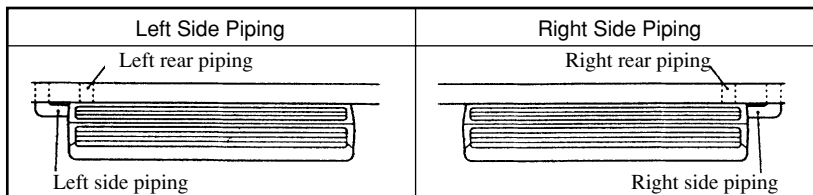

[Procedure for exchanging the drain hose.]

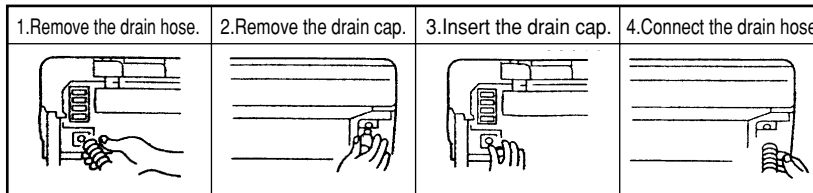

- Loosen and remove the spring-type clamp.
- Remove with your hand or a pair of pliers.
- Use a hexagonal wrench to correctly insert the drain cap which was removed in 2. Caution: Be careful because if the cap is not inserted properly, water leak may occur.
- Loosen the spring-type clamp and securely insert the drain hose. Caution: Be careful because if the cap is not inserted properly, water leak may occur.

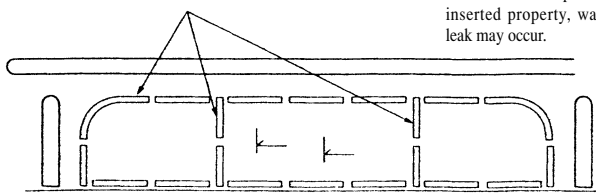

The piping can be removed from the rear, left, left rear, right and from under the unit.

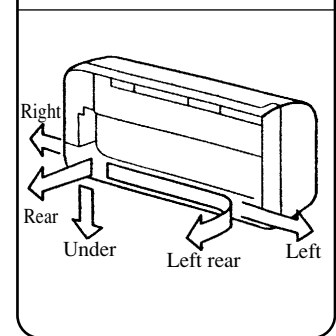

- Do not place the power supply cords above the gutter, because the air conditioner is structured in a way where condensation on the back side is collected in to the drain pan before drainage.

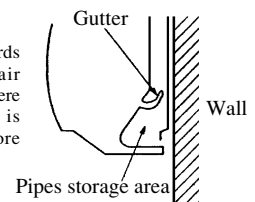

**Drainage**

- The drain hose must be fit with a downward slope.
- Do not set the drain hose like the following illustrations.

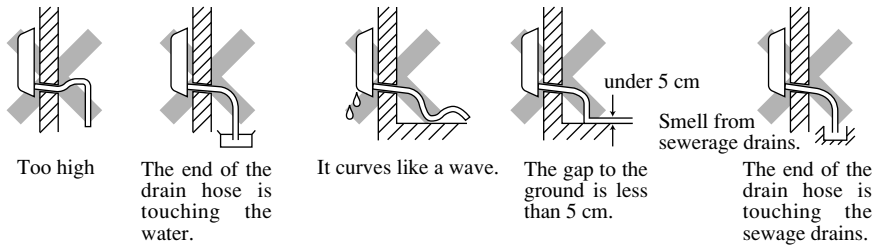

- Pour water in the drain pan below the heat exchanger and confirm that the water is drained outside.
- If the extension drain hose is indoors, make sure it is insulated using a shielding pipe (not supplied).

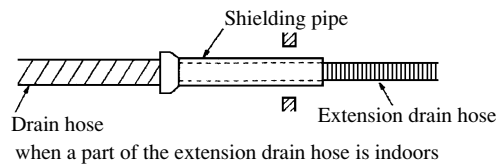

**5) Securing the Indoor Unit to the Installation Board**

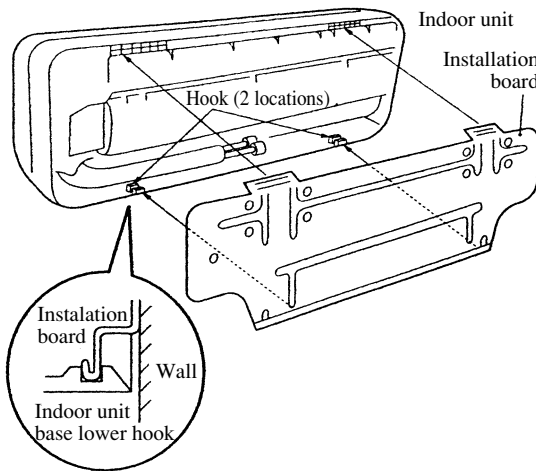

Installing steps	
	1. Hook the upper part of the indoor unit to the installation board.
↓	
	2. The unit can be installed simply by gently pushing in the lower part.

**5.5.2 Installation of remote controller**

**(1) Mounting method of battery**

Uncover the remote control switch, and mount the batteries (UM-4 × 2 pieces) in the body regularly.

(Fit the poles with the indication marks, ⊕ & ⊖ without fail)

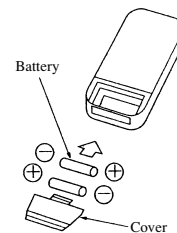

**(2) Fixing to pillar or wall**

- Conventionally, operate the remote control switch by holding in your hand.
- In the case of stationary operation service as by mounting on the holder for the remote control switch, make sure that the locating place is satisfactory for access service before installing it.
- Avoid installing it on a clay wall etc.

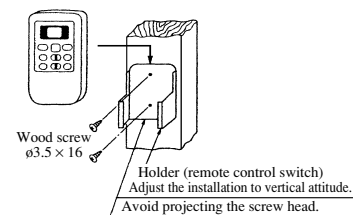

### 5.5.3 Installation of outdoor unit

#### (1) Selection of installation location

(Please install with the customer's consent in a location that follows the conditions listed below.)

- (a) Where the following installation space is available, and where air does not gather.
- (b) Where rain and sunlight do not directly hit the unit, and where there is enough air circulation.
- (c) Also, where the unit cannot be buried by snow.

A location which can sustain the weight of the unit, and where noises and vibrations are not enhanced.

- (d) Where blasts of cold or hot air and noise do not bother the neighbors.
- (e) Where the unit does not receive heat radiation from other heat sources.
- (f) Where there are no obstructions (animals, plants, etc.) to the suction inlet and blowing outlet.
- (g) Where water may drain out.
- (h) Please avoid the following locations.
  - 1) Where there is constant exposure to harsh winds such as the top floors of a building. Also, locations with exposure to salty air.
  - 2) Where there are oil splashes, vapor, and smoke.
  - 3) Where there are possibilities of flammable gas leaks.

#### (i) Installation space (on a flat surface)

If there are no open space to install the unit, and it must be installed in a location where there are obstructions such as a wall to the suction inlet and the blowing outlet, please observe the following points. In such cases, please also be aware that the performance of the cooling/heating system may decline by approximately 10%.

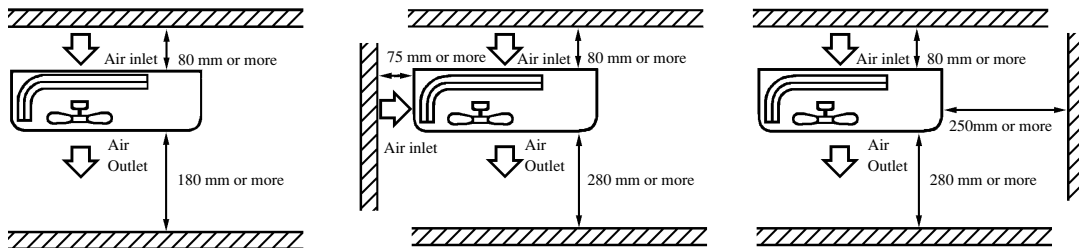
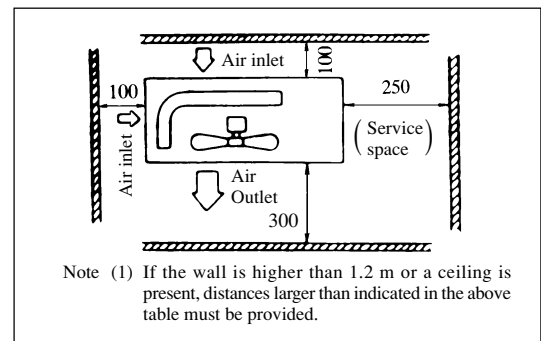

#### (2) Installation of outdoor unit

- (a) Make sure that sufficient space for installation and service is secured.
- (b) Fix the leg sections of the unit on a firm base which will not play.  
Attach cushion pads, etc. between the unit and the mounting fixtures not to transmit vibration to the building.
- (c) Attach a drain elbow, etc. under the drain port of the bottom plate to guide drain water.  
(Drain elbow should not be used where days when temperature drops below 0°C continue for several days. Draining may be disturbed by frozen water.)
- (d) When installing the unit at a higher place or where it could be toppled with strong winds, secure the unit firmly with foundation bolts, wire, etc.

### 5.5.4 Electrical wiring

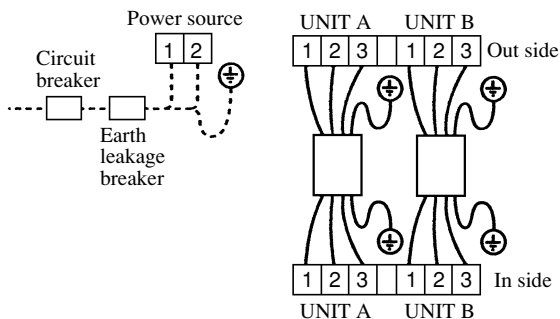

**(1) Connection of the power lines**

- (a) This multi-type room air conditioner receives its power from outside.
- (b) It is necessary to use a single phase 200/240 V 50 Hz for the power supply.
- (c) An earth leakage breaker and a circuit breaker must be installed.  
Their capacities are listed below.
- (d) Use the power supply wires specified below. Different wires may cause heat generation and fire. Do not to use unspecified wires.  
Never bundle, wind or treat the power wires. Otherwise, heat or fire may be generated.

SCM452HENG-L	25A
SCM452CENG-L	25A

Use cables for interconnection wiring to avoid loosening of the wires.  
CENELEC code for cables Required field cables.  
H05 RNR3G4.0 (Example)  
H Harmonized cable type  
05 300/500 volts  
R Natural-and/or synth. rubber wire insulation  
N Polychloroprene rubber conductors insulation  
R Stranded core  
3 Number of conductors  
G One conductor of the cable is the earth conductor (yellow/green)  
4.0 Section of copper wire (mm<sup>2</sup>)

[POWER SUPPLY CODE]

CENELEC code for cables required field cables.  
H05RNR3G 4.0

- (e) After connecting the power supply wires, make sure to secure the wires with wiring clamps.

**(2) Connecting the outside/inside crossover wires**

- (a) Ensure that crossover wiring is matched with crossover piping in A and B rooms.
- (b) The length of the crossover wires should be under 25 m. If it longer than 25 m, signal errors between the units may occur and cause the operation to shut down.
- (c) Use the crossover wires specified below. Different wires may cause heat generation and fire. Do not to use unspecified wires.

[INTERCONNECTING WIRING CODE]

CENELEC code for cables required field cables.  
H05RNR4G 1.5

- (d) Make sure the terminal numbers on the terminal board of the indoor and outdoor connections are correct.
- (e) After connecting the crossover wires to the terminal board, use wiring clamps to secure the wiring.

## 5.5.5 Refrigerant Piping

### (1) Limit

The maximum permissible length of the refrigerant pipes for the outdoor units, and the maximum permissible height difference for the outdoor units are as shown below.

Length for one indoor unit		Under 25m
Total length for all rooms		Under 30m
Height difference	Lower installation spot of the indoor unit A	Under 15m
	Upper installation spot of the indoor unit B	Under 10m
	Maximum height difference of the indoor units C	Under 10m
Length of chargeless refrigerant pipe		20m

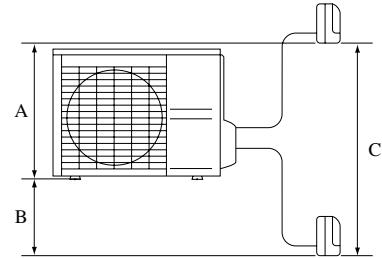

\* If the total length for all the rooms exceeds the length of chargeless refrigerant pipe, additionally charge with refrigerant according to the item 4.

#### • The diameter of the refrigerant pipe:

Class of indoor unit (kW)		2.2 · 2.5 · 2.8kW	3.2 · 4.0kW
Diameter of joint pipe	Liquid side	ø 6.35 · t 0.8	
	Gas side	ø 9.52 · t 0.8	ø 12.7 · t 0.8

#### • Outdoor unit and the total connectable indoor units (class kW):

Model	Total of indoor units (class kW)
SCM452HENG-L	6.5kW
SCM452CENG-L	6.5kW

### (2) Connection of refrigerant piping

- The service valve corresponding to each indoor unit is as illustrated in the right figure.
- Changing the gas side piping size

If the piping connection for the gas side of the outdoor unit does not match the piping size of the indoor unit, use the parts provided for variable connections to make the joint.

Variable diameter joint (provided): ø9.52 → ø12.7 (1 piece)

[Examples of use of variable diameter joints]

Connection of indoor unit of Class 4.0 to A unit.

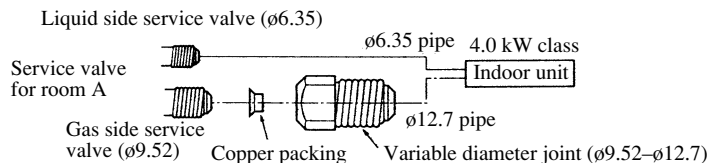

- Securely fit the copper packing between the service valve and the variable diameter joint to prevent shifting.
- Cover the pipes with tape so that dust and sand do not enter the pipe until they are connected.

[Connection of pipes]

- When connecting the pipes to the outdoor unit, be careful about the discharge of fluorocarbon gas or oil.
- Make sure to match the pipes between the indoor unit and the outdoor unit with the correct service valves.

#### (1) Preparations

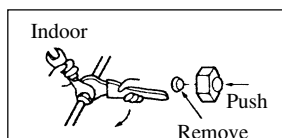

- Remove the flare nut (from both liquid and gas sides).

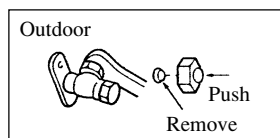

- Remove the flare nut (from both liquid and gas sides).

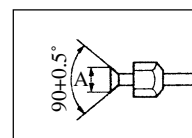

- Fit the removed flare nut to the joint pipe, and then flare it.

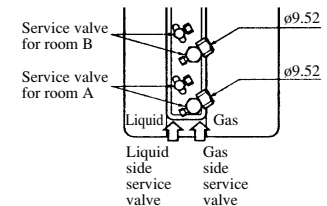

A dimensions  
Liquid side:  
ø 6.35: ø 9 ~ ø 9.5  
Gas side:  
ø 9.52: ø 13.2 ~ ø 14  
ø 12.7: ø 16.2 ~ ø 17

(2) Connection

Indoor

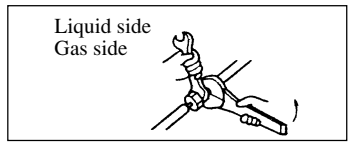

- Secure the nut with a specified tightening torque to avoid any gas leaks.

Outdoor

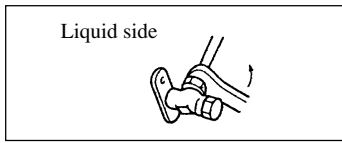

- Secure the nut with a specified tightening torque to avoid any gas leaks.

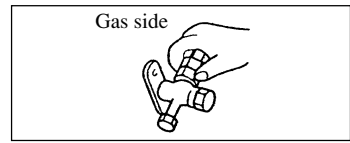

- When air purging with a vacuum pump, secure the nut with a specified tightening torque to avoid any gas leaks.
- When air purging with a refrigerant from an outdoor unit, just temporarily secure the nut.

- Specified tightening torques are as follows:  
 Liquid side (ø 6.35): 17mm in width across flat of the flare nut: 15.7-19.6 N·m (1.6-2.0 kgf·m)  
 Gas side (ø 9.52): 22mm in width across flat of the flare nut: 29.4-39.2 N·m (3.0-4.0 kgf·m)  
 Gas side (ø 12.7): 24mm in width across flat of the flare nut: 39.2-49.0 N·m (4.0-5.0 kgf·m)

(3) Air purging

To protect the global environment, use a vacuum pump that do not release flouorocarbon gas into the atmosphere. When a vacuum pump cannot be used due to certain conditions for installation, sufficient refrigerant is available for air purging with refrigerant for the outdoor unit.

Note: Fully open the service valves (on both liquid and gas sides) after completing air purging

- Remove the cap on both gas and liquid sides before starting operation.
- After completing the operation, do not forget to tighten the cap (gas may leak).
- Conduct air purging for all connected indoor units.

Procedure

- Secure all flare nuts on both indoor and outdoor sides to prevent leaks from the pipes.
- Connect the service valves, charge hose, manifold valve and vacuum pump as shown in the right figure.
- Fully open the handle Lo for the manifold valve, and pump a vacuum for 15 minutes. Ensure that the meter is indicating -0.1 MPa (-76cmHg).
- After vacuuming, fully open the operational valve (both liquid and gas sides) with a hexagon wrench.
- Ensure that there are no gas leaks from the joints in the indoor and outdoor units.
- Repeat the above steps ① ~ ⑤ for all connected indoor units.

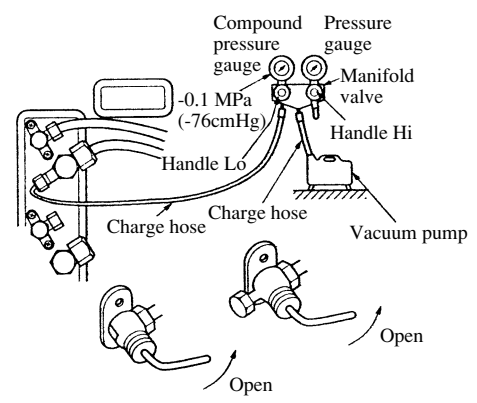

(4) Additional refrigerant charge

- When the total refrigerant pipe length for all the rooms exceeds the length of the uncharged pipe (20m), additional refrigerant is required.  
(If 20m or less, additional charge is not required.)
- For this multi type room air conditioner, it is not necessary to charge the refrigerant for the total maximum length in all the rooms.

Model	Charged pipe length (Amount of uncharged refrigerant) *1	On site additional charge	Maximum total pipe length for all rooms (Maximum amount of refrigerant)
SCM452HENG-L SCM452CENG-L	1300g	20g/m	1500g

\*1: Charge amount at the time of shipment.

- Ensure that there are no gas leaks from the pipe joints by using a leak detector or soap water.

**(5) Heat insulation for joint**  
**Heat insulation for joints**

**Finish and fixing**

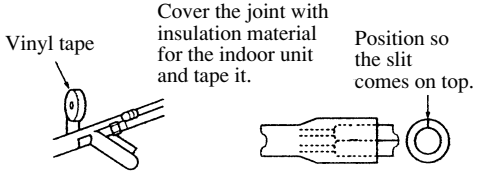
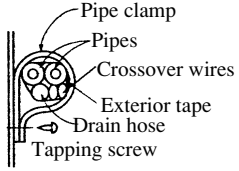
		<p>Apply exterior tape and shape along the place where the pipes will be routed. Secure to the wall with a pipe clamp. Be careful not to damage the pipes and the wires.</p>
---	--	--

**5.5.6 Test run and handling instruction**

**(1) Inspection**

Check according to the following check items.

**(2) Test run**

- (a) Carry out the test run for each unit individually. (If 2 units are tested at the same time, wrong wiring and wrong pipe connections cannot be checked.)
- (b) After each individual test, run the units in all the rooms simultaneously and check the units.
- (c) Test both the cooling and the heating.

**(Three-minute restart preventive timer)**

When the air conditioner is restarted or when changing the operation, the unit will not start operating for approximately 3 minutes. This is to protect the unit and it is not a malfunction.

**Installation test check points**

Check the following points again after completion of the installation, and before turning on the power. Conduct a test run again and ensure that the unit operates properly. At the same time, explain to the customer how to use the unit and how to take care of the unit following the instruction manual.

**After installation**

- The power supply voltage is correct as the rating.
- No gas leaks from the joints of the service valve.
- Power cables and crossover wires are securely inserted and fixed to the terminal board.
- Each indoor and outdoor unit is properly connected (no wrong wiring or piping).
- Service valve is fully open.
- Refrigerant has been additionally charged (when the total pipe length exceeds the refrigerant charged pipe length).
- The pipe joints for indoor and outdoor pipes have been insulated.
- Earthing work has been conducted properly.

**Test run**

- Air conditioning and heating are normal.
- No abnormal noise.
- Water drains smoothly.
- Protective functions are not working.
- Operation of the unit has been explained to the customer.

**Beware of wrong connections in refrigerant piping and wiring**

- Make sure to match the piping and wiring from each unit to the outdoor unit.
- Be careful because if connections are wrong, normal operation cannot be achieved and may damage the compressor.

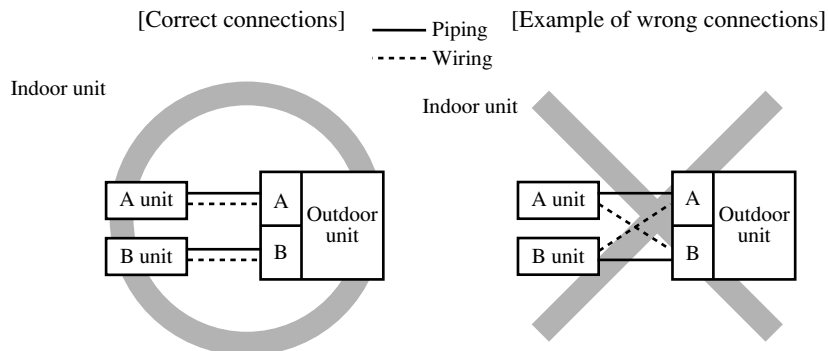



## 5.6 MAINTENANCE DATA

### 5.6.1 Trouble shooting

#### (1) Trouble shooting to be performed prior to exchanging PCB, (Printed circuit board) [Common to all models]

All the models described in this chapter are controlled by a microcomputer. When providing maintenance service to customers it is necessary to understand the function controlled by a micro computer thoroughly, so as not to mistakenly identify correct operations as mis-operations. It is also necessary to perform the following simple checks before conducting detailed checks or exchanging printed circuit board.

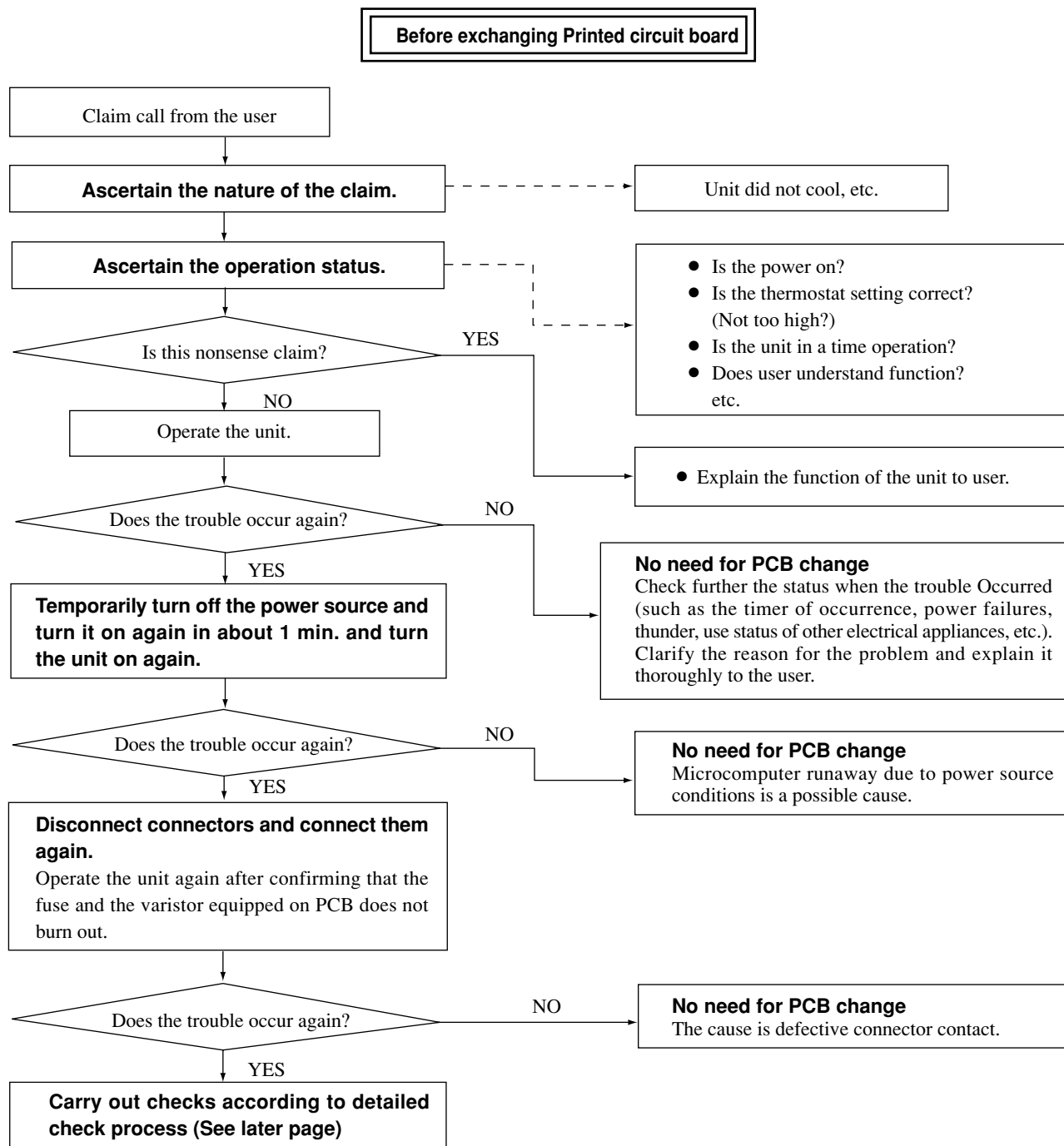

**(2) Indication of self diagnosis**

Indoor unit indicator		Outdoor unit indicator (LED 2)	Description of trouble	Cause	Conditions of flashing
RUN lamp	TIMER lamp				
1 time flash	Comes on	Stays off	Heat exchanger thermistor error	<ul style="list-style-type: none"> <li>Broken heat exchanger thermistor wire</li> <li>Connector poor connection</li> </ul>	When heat exchanger thermistor temperature of $-20^{\circ}\text{C}$ or under continued for more than 3 seconds while operation is stopped. (This is not displayed during operation.)
2 time flash	Comes on	Stays off	Room temperature thermistor error	<ul style="list-style-type: none"> <li>Broken room temperature thermistor wire</li> <li>Connector poor connection</li> </ul>	When room temperature thermistor temperature of $-20^{\circ}\text{C}$ or under continued for more than 3 seconds while operation is stopped. (This is not displayed during operation.)
6 time flash	Comes on	Stays off	Indoor fan motor error	<ul style="list-style-type: none"> <li>Defective fan motor</li> <li>Connector poor connection</li> </ul>	When air conditioner is operating and indoor fan motor is turned ON, indoor fan motor speed of 400 rpm or under continued for more than 30 seconds. (Air conditioner stops.)
Keeps flashing	1 time flash	Stays off	Outdoor temperature thermistor error	<ul style="list-style-type: none"> <li>Broken outdoor thermistor wire</li> <li>Poor connector connection</li> </ul>	When outdoor temperature thermistor temperature of $-40^{\circ}\text{C}$ or under continued for more than 3 seconds while operation is stopped. (This is not displayed during operation.)
Keeps flashing	2 time flash	Stays off	Outdoor heat exchanger fluid pipe thermistor error	<ul style="list-style-type: none"> <li>Broken heat exchanger fluid pipe thermistor wire</li> <li>Poor connector connection</li> </ul>	When heat exchanger entrance thermistor temperature of $-50^{\circ}\text{C}$ or under continued for more than 3 seconds while operation is stopped. (This is not displayed during operation.)
Comes on	1 time flash	1 time flash	Current cut	<ul style="list-style-type: none"> <li>Compressor locking</li> <li>Open phase on compressor output</li> <li>Shortcircuit on power transformer</li> </ul>	When converter output current which exceeds setting value is detected. (Compressor stops.)
Comes on	2 time flash	2 time flash	Trouble of outdoor unit	<ul style="list-style-type: none"> <li>Defective power transistor.</li> <li>Broken compressor wire</li> <li>Compressor blockage</li> </ul>	When an error with the outdoor unit causes an error stop, or when the input current is measured at 1 A or less for 3 continuous minutes or more. (Compressor is stopped.)
Comes on	2 time flash	On for 4 seconds and off for 4 seconds	Comp. dome thermistor error	<ul style="list-style-type: none"> <li>Broken comp. dome thermistor wire</li> <li>Connector poor connection</li> </ul>	After the outdoor unit speed has been 0 rps or more for 10 continuous minutes and the compressor dome thermistor has sent a 10 second or more broken wire signal (less than $7^{\circ}\text{C}$ ). (Compressor is stopped.)
Comes on	3 time flash	3 time flash	Current safe stop	<ul style="list-style-type: none"> <li>Overload operation</li> <li>Overcharge</li> </ul>	When the actual speed is 28 rps or less and the current save has operated. (Compressor stops)
Comes on	5 time flash	5 time flash	Over heat of compressor	<ul style="list-style-type: none"> <li>Gas shortage</li> <li>Defective comp. dome thermistor</li> </ul>	When comp. dome thermistor value exceeds setting value. (Compressor Stops.)
Comes on	6 time flash	6 time flash	Error of signal transmission	<ul style="list-style-type: none"> <li>Defective power supply</li> <li>Broken signal wire</li> <li>Defective indoor/outdoor unit circuit boards.</li> </ul>	If serial signal cannot be sent or received for 1 minute and 55 seconds continuously.
Comes on	2 time flash	7 time flash	Compressor lock	<ul style="list-style-type: none"> <li>Defective compressor</li> <li>Defective outdoor PCB</li> </ul>	When the motor for the compressor does not turn a half a turn approximately 0.3 seconds after it has been started.
Comes on	2 time flash	Comes on	Outdoor fan motor error	<ul style="list-style-type: none"> <li>Defective fan motor</li> <li>Connector poor connection</li> </ul>	When the outdoor unit fan motor operates at 300 rpm or less for 30 seconds or more continuously.

(3) Inspection procedures corresponding to detail of trouble

**Thermistor error**

[Broken thermistor wire, connector poor connection]

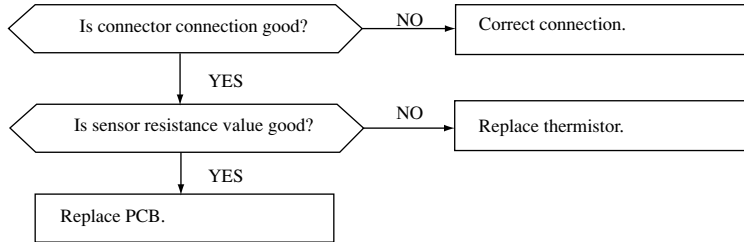

◆ Comp. dome thermistor temperature characteristics

Temperature (°C)	Resistance (kΩ)	Temperature (°C)	Resistance (kΩ)
0	164	70	8.7
5	127	75	7.3
10	99	80	6.2
15	78	85	5.3
20	62	90	4.5
25	50	95	3.9
30	40	100	3.3
35	32	105	2.9
40	26	110	2.5
45	21	115	2.2
50	17	120	1.9
55	14	125	1.6
60	12	130	1.4
65	10	135	1.3

◆ Thermistor temperature characteristics (Room temperature, indoor unit heat exchanger temperature, outdoor unit heat exchanger temperature, outdoor temperature)

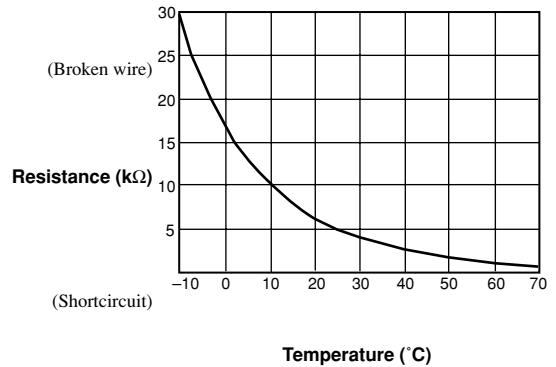

**Current cut**

[Open phase on compressor output terminal, compressor lock]

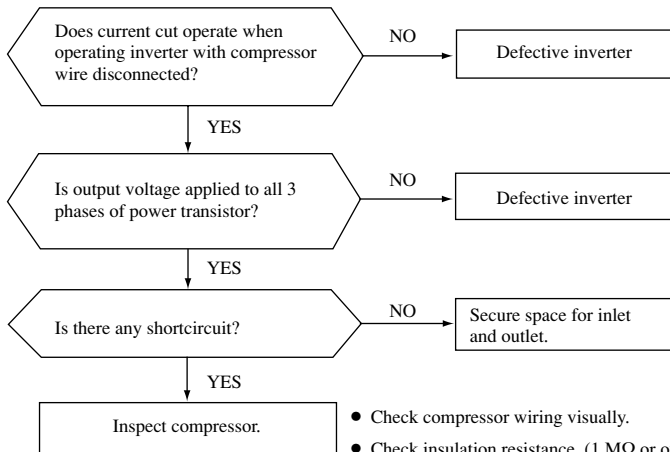

- Check compressor wiring visually.
- Check insulation resistance. (1 MΩ or over)
- Check coil wire resistance. (Few Ω)

— If check results are normal, compressor is locked.

**Outdoor unit error**

[Broken power transistor, broken compressor wire]

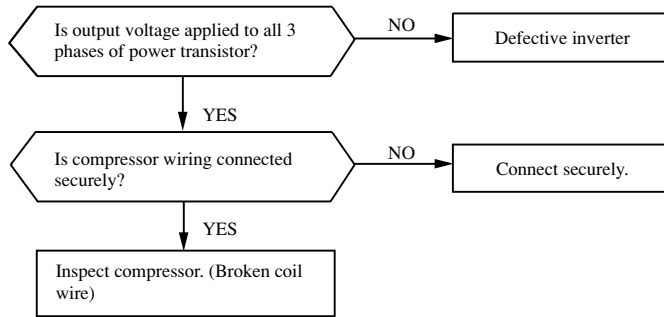

**Current safe stop**

[Overload operation, compressor lock, overcharge]

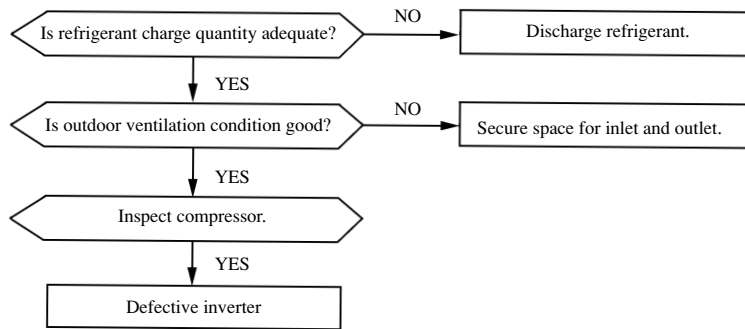

**Compressor overheat**

[Gas shortage, defective comp. dome thermistor]

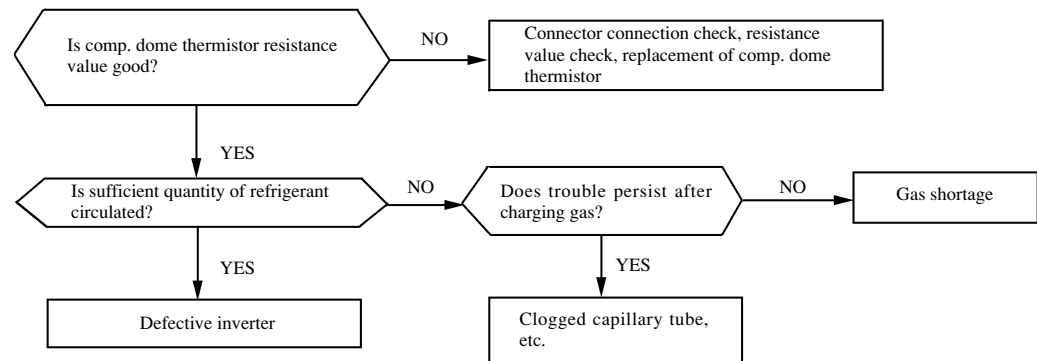

**Indoor fan motor error**

[Defective fan motor, defective indoor PCB]

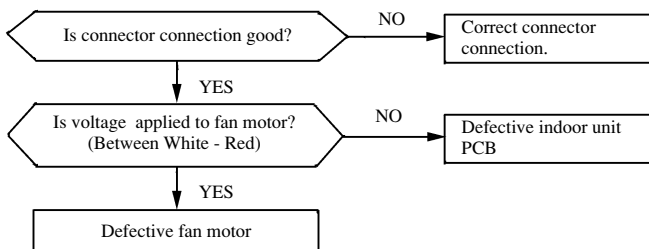

### Outdoor fan motor error

[Defective fan motor, defective outdoor PCB]

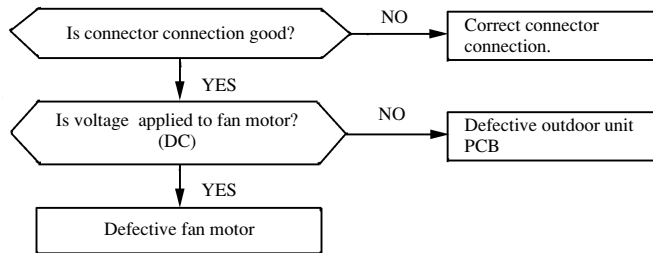

### Serial signal transmission abnormality

[Indoor/outdoor printed circuit board defect  
Outdoor power source abnormality]

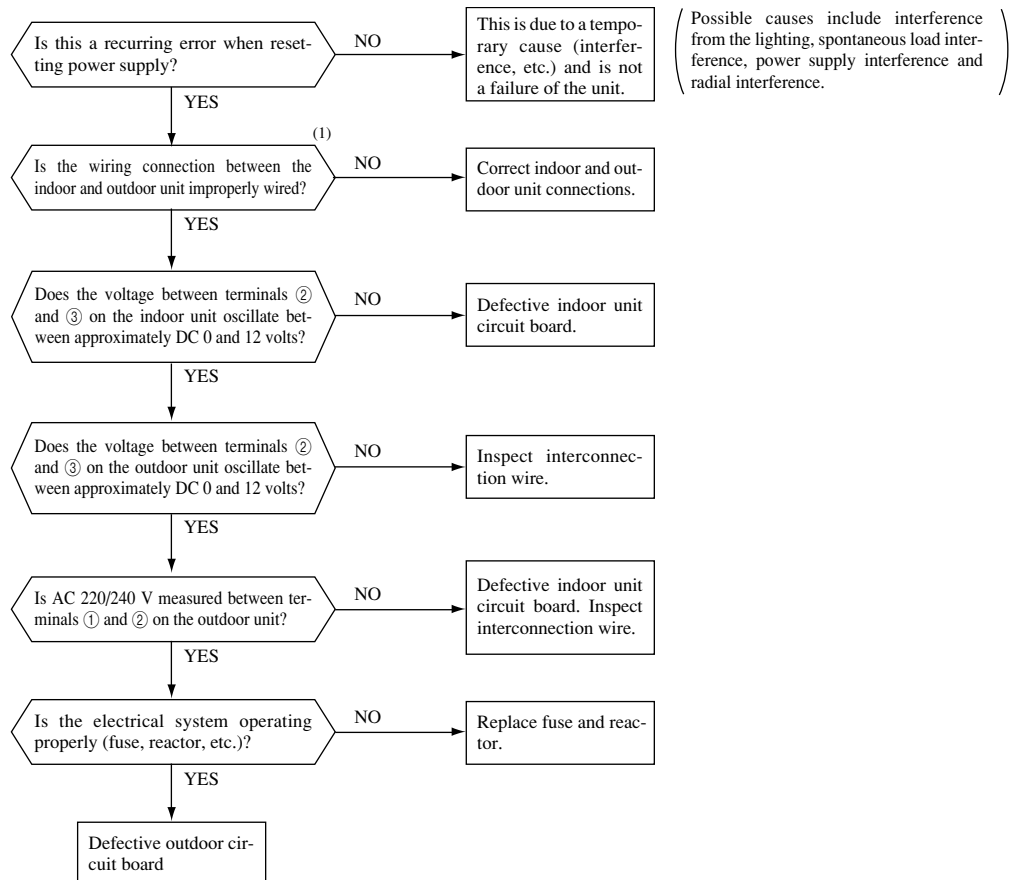

### Compressor lock

[Defective compressor, defective outdoor PCB]

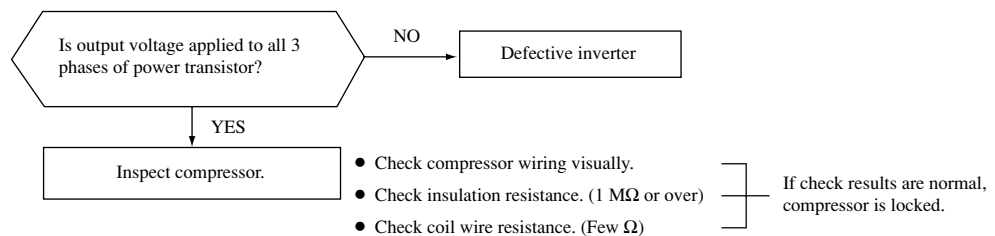

(4) Phenomenon observed after shortcircuit, wire breakage on thermistors.

(a) Indoor unit

Sensor	Operation mode	Phenomenon	
		Shortcircuit	Broken wire
Room temperature thermistor	Cooling	Release of continuous compressor operation command	Continuous compressor operation command is not released.
	Heating	Continuous compressor operation command is not released.	Release of continuous compressor operation command
Heat exchanger thermistor	Cooling	System can be operated normally.	Continuous compressor operation command is not released. (Anti-frosting)
	Heating	High pressure control mode (Inverter stop command)	Hot keep (Indoor fan stop)

(b) Outdoor unit

Thermistor	Operation mode	Phenomenon	
		Shortcircuit	Broken wire
Heat exchanger pipe thermistor	Cooling	System can be operated normally.	
	Heating	Defrosting is not performed.	Defrosting is performed for 10 minutes at approx. 1 hour.
Outdoor temperature thermistor	Cooling	System can be operated normally.	
	Heating	Defrosting is not operated.	Defrosting is performed for 10 minutes at intervals of approx. 30 minutes.
Comp. dome thermistor	All modes	Compressor overload protection is disabled. (Can be operated.)	Compressor stop (There is no inverter output.)

(5) How to make sure of remote controller

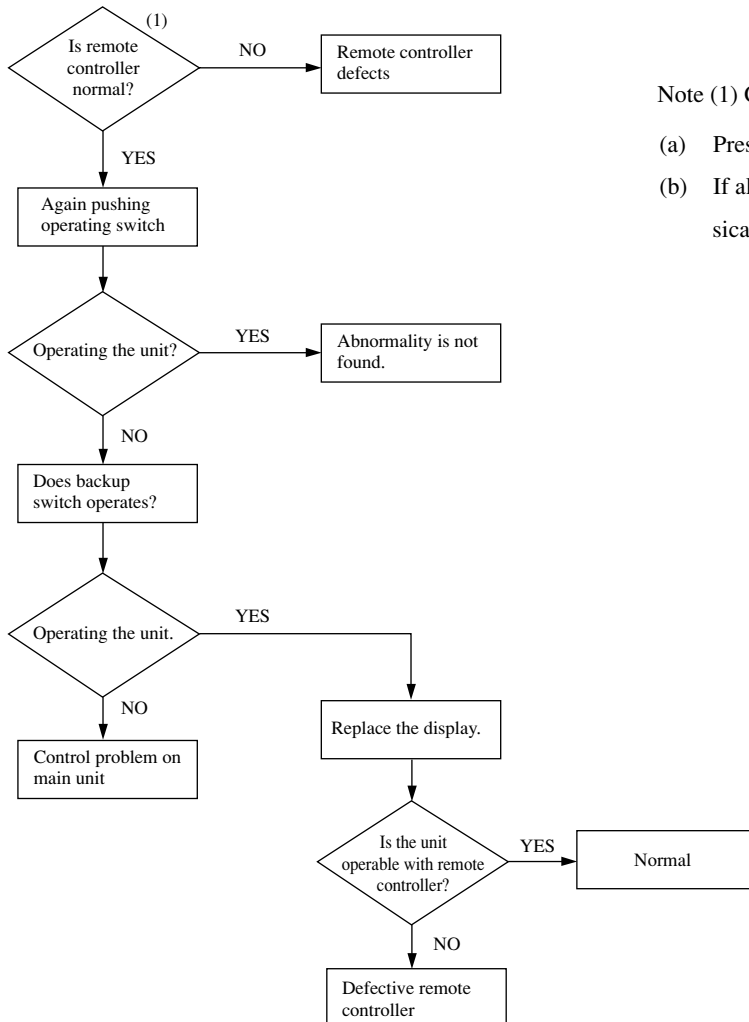

Note (1) Check method of remote controller

- (a) Press the reset switch of the remote controller.
- (b) If all LCD are displayed after zero (0) display, it is basically normal.

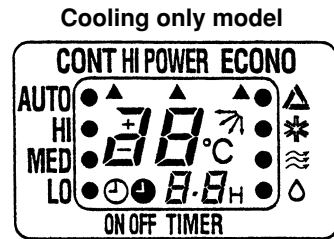
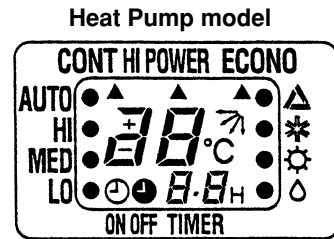

**(6) Indoor electrical components inspection flowchart**

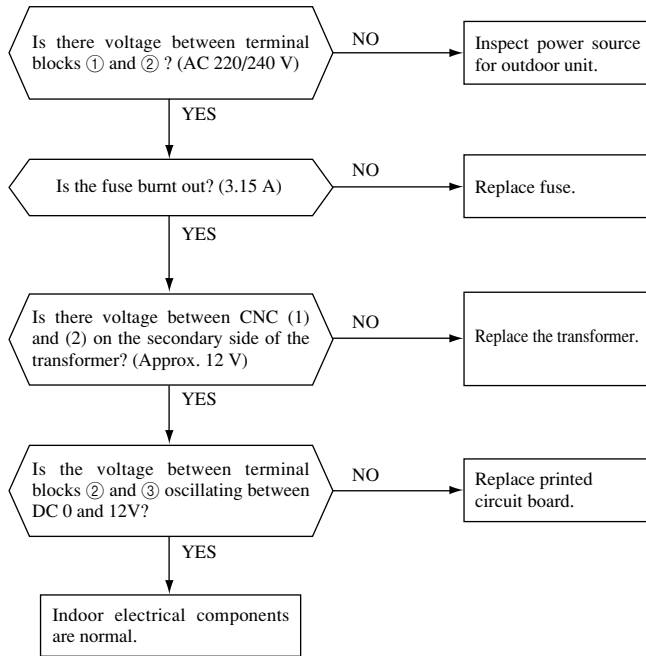

(7) Outdoor unit inspection points

**⚠ CAUTION – HIGH VOLTAGE**  
 High voltage is produced in the control box. Don't touch electrical parts in the control box for 5 minutes after the unit is stopped.

**• Display lamp inspection**  
 • LED 2 (Abnormality display lamp - Red) ON or flashing: Protection function operating  
 • LED 1, 3 to 6: (Light display for each room - Green) ON when there is a serial signal being received among each of the indoor units. OFF during ignition, stop abnormality.

**• Power source and serial signal inspection**  
 ① to ②: AC220/240V  
 ② to ③: Normal if the voltage oscillates between DC 0 and approx. 12V

**◆ Inspection of reactor conductivity**  
 Remove the connector and check for conductivity. It must be conductive.

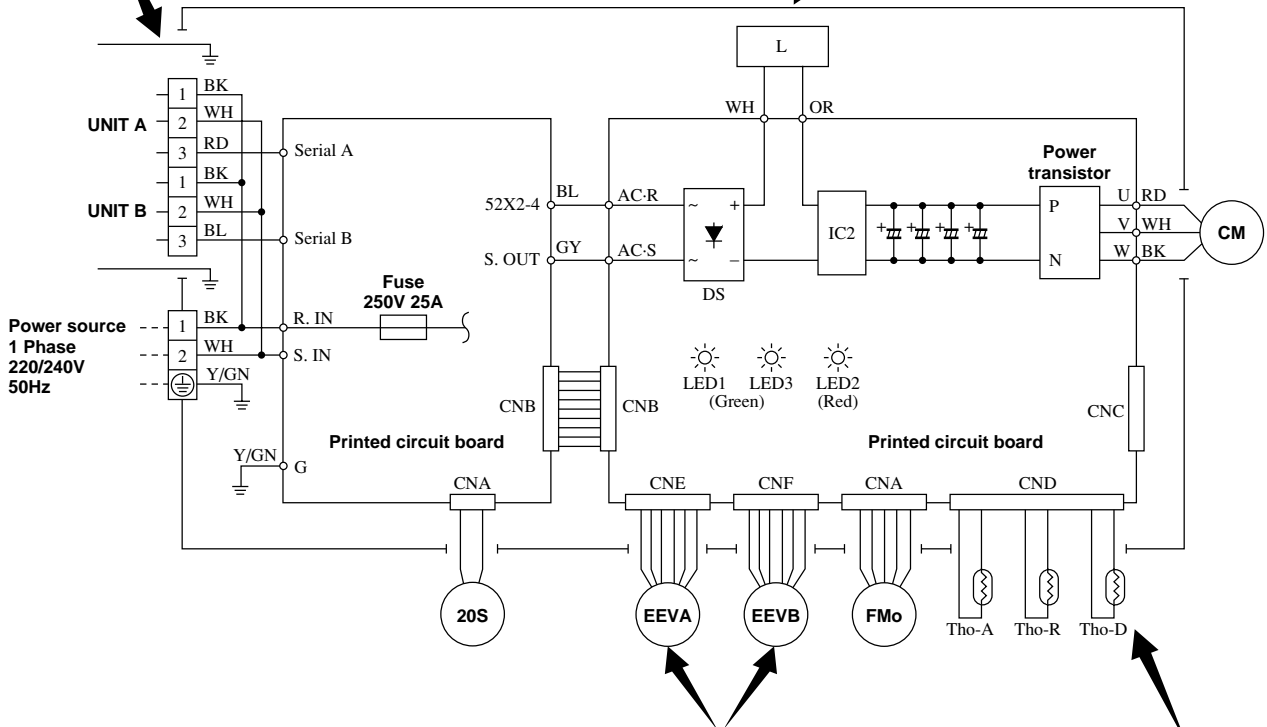

**• Inspection of electronic expansion valve**  
**To test if there is voltage.**  
 (Voltage is only applied to the electronic expansion valve when the valve angle is being changed.)  
 Red to white  
 Red to Orange  
 Brown to yellow  
 Brown to blue  
 } Normal if there is approximately DC 5 V 10 seconds after the power supply is turned on.  
**If the expansion valve does not operate as shown above, it is defective.**

**◆ Inspection of resistance value of Comp. dome thermistor**  
 Remove the connector and check the resistance value. See the section of thermistor characteristics on page 213.

**◆ Power transistor inspection procedure**

[Use a tester with a needle indicator for the inspection. (Do not use a digital tester. Check in the AC 300 volt range.)]

(1) If there is a self-diagnosis display, inspect the compressor system (burns, wiring mistakes, etc.). If no problems are found, check the output of the power transistor.

(2) Output inspection procedure

Disconnect the terminals for the compressor. If an output such as the one shown in the figure on the right can be measured, the power transistor and the circuit board for the outdoor unit are normal.

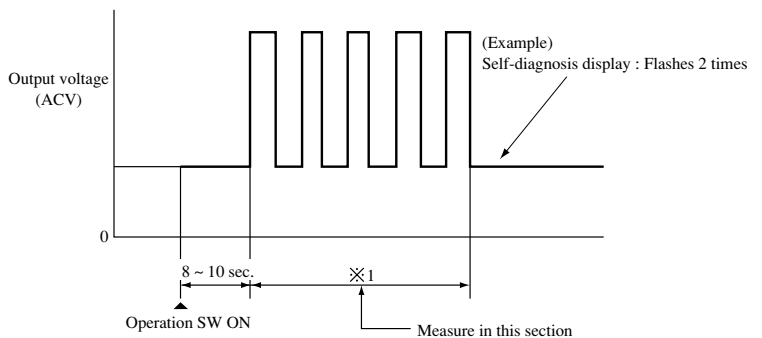

※ For about 50 seconds. After being switched on, there will be a delay of approximately one minute depending on the conditions.



## 5.6.2 Servicing

### (1) Evacuation

The evacuation is an procedure to purge impurities ..... noncondensable gas, air, moisture from the refrigerant equipment by using a vacuum pump. Since the refrigerant R22 is very insoluble in water, even a small amount of moisture left in the refrigerant equipment will freeze, causing what is called water clogging.

- Evacuation procedure

- Check to ensure that there is no internal pressure in the unit. If there is an internal pressure, it should be relieved through the check joint.
- Connect the service hoses of the gauge manifold to the check joint of the gas & liquid piping.
- Connect a vacuum pump to the charge hose (A). Repeat evacuation in the following sequence.

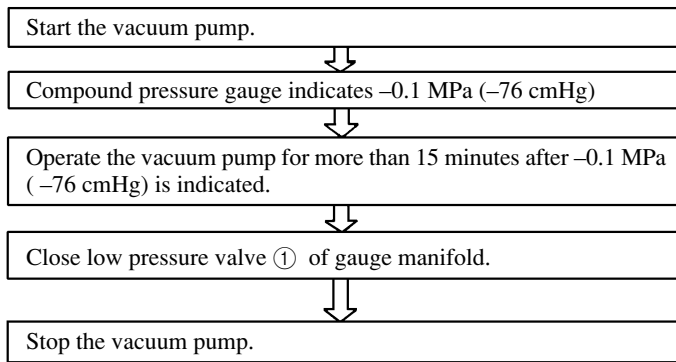

- Notes
- (1) Do not use the refrigerant pressure to expel air.
  - (2) Do not use the compressor for evacuation.
  - (3) Do not operate the compressor in the vacuum condition.

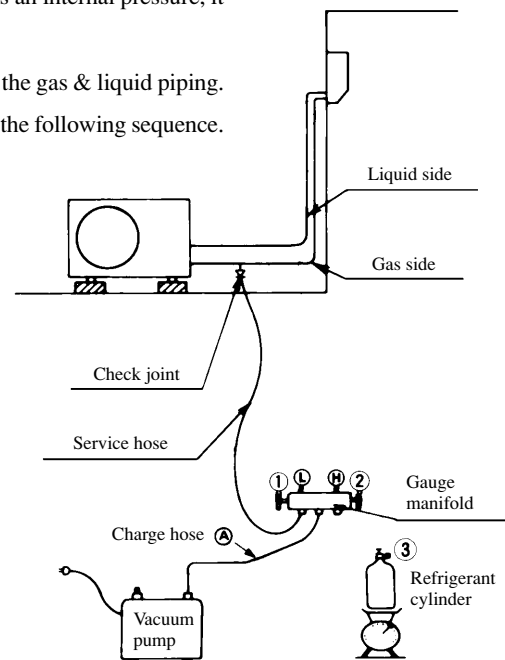

### (2) Refrigerant charge

- Discharge refrigerant entirely from the unit and evacuate the unit.

Note: Addition of refrigerant without evacuation is unreasonable, because it will result in low charge or overcharge.

- Keep the gauge manifold and connect a refrigerant cylinder to the unit.
- Record the weight of the refrigerant cylinder on the balance. This is necessary for making sure of the charged refrigerant amount.
- Purge air from the charge hose (A)
 

Firstly loose the connecting portion of the charge hose (A) at the gauge manifold side and open the valve (3) for a few seconds, and then immediately retighten it after observing that gas is blow out from the loosened portion.
- Open the valve (1) and (3) after discharging air from the charge hose (A), then the gas refrigerant begins flowing from the cylinder into the unit. Be sure to erect the refrigerant cylinder upright to let gas refrigerant flow into the unit.
- When refrigerant has been charged into the system to some extent, **refrigerant flow becomes stagnant, when that happens, start the compressor in cooling cycle until the unit is filled with gas to the specified weight.**
- Making sure of the refrigerant amount, close the valve (3).
- Disconnect the charge hose from the unit. Cover the valve ports of the refrigerant piping with caps and tighten them securely.
- Check for gas leakage applying a gas leak detector along the piping line.
- Start the air conditioner and make sure of its operating condition ..... high side and low side pressures and temperature difference between suction air and outlet air.