

AHU Controller Specifications

1. Application

This controller is used to set up a system by connecting a field-supplied Air Handling Unit (AHU) to Mitsubishi Electric City Multi outdoor unit.

Applicable models: PAC-AH125, 140, and 250M-H

2. System restrictions and use of range

(1) System configuration

Connectable outdoor units	PUHY-P250,300,350,400,450,500YGM-A
Refrigerant type	R410A
Capacity of connectable AHU units	80~100% of outdoor unit capacity
Connectable indoor units	Do not group the AHU with the standard indoor unit.

(2) Operating conditions

Operating conditions of indoor, outdoor, air handling units (cooling/heating)

Unit Type	Cooling	Heating
AHU (Heat exchanger inlet air temperature)	15~24°CWB	-10~15°CDB
Outdoor unit	-5~43°CDB	-20~15.5°CWB

(3) Refrigerant pipe size, pipe length, and height difference restrictions

Model names	Unit capacity	Pipe size(Liquid / Gas)
PAC-AH125M-H PAC-AH140M-H	100, 125, 140	Φ9.52 / Φ15.88
PAC-AH250M-H	200	Φ9.52 / Φ19.05
	250	Φ9.52 / Φ22.2

Pipe length
Height difference

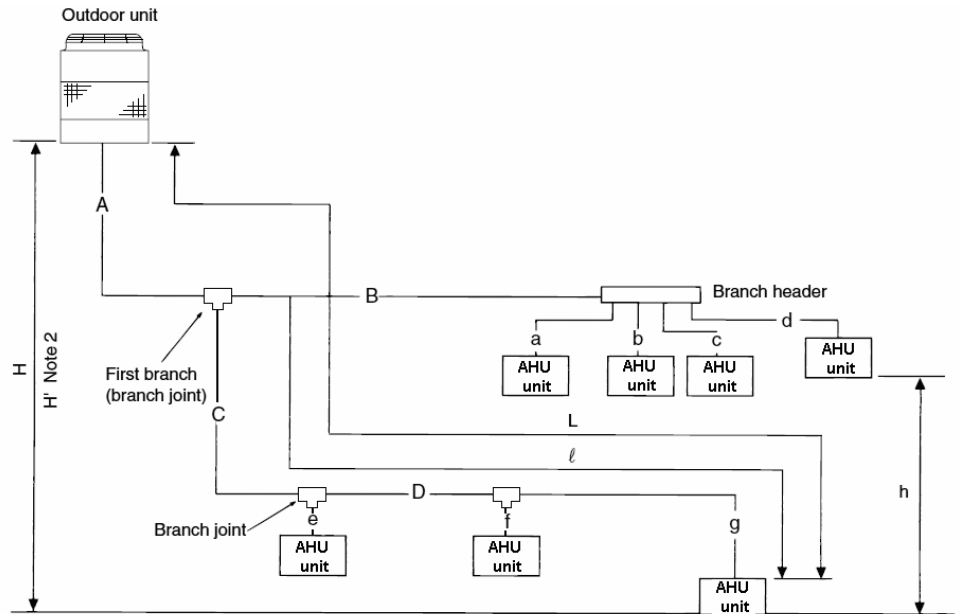

- (a) No further branching in the pipes is possible after the header branch.
- (b) Cooling operation is performed when the outdoor temp. is 0°C or lower :
H'=4m or less
- (c) Equivalent pipes length(m) : Actual pipe length + A × number of bent.

Table A

Outdoor unit model	A	Outdoor unit model	A
P250	0.42	P400	0.50
P300	0.42	P450	0.50
P350	0.47	P500	0.50

Item	Pipe section	Allowable length	Equivalent length
Total pipe length	A+B+C+D +a+b+c+d+e+f+g	300m max.	-
Furthest pipe length (L)	A+C+D+g or A+B+d	150m max	175m max.
Furthest pipe length (ℓ) after first branch	C+D+g or B+d	40m max.	40m max.
Btwn. AHU & outdoor units	Outdoor unit installed above	H	50m max.
	Outdoor unit installed below	H'	40m max.
Btwn. AHU & AHU units	h	15m max.	-

Amount of refrigerant to be added	(a) Original charge of refrigerant and the maximum total charge. At factory shipment, refrigerant are charged in the outdoor unit as shown at following Table. When extending the piping in the field, additional charge of refrigerant is needed. Yet, the maximum total charge in the air conditioner system should not be exceeded. The maximum additional charge varies on models, shown as the following Table.																									
	<p style="text-align: center;">Table</p> <table border="1"> <tr> <td>PU(H)Y-YGM</td> <td>P250,300,350</td> <td>P400</td> <td>P450,500</td> </tr> <tr> <td>Original charge A(kg)</td> <td>9.5</td> <td>13.0</td> <td>22.0</td> </tr> <tr> <td>Maximum total charge B(kg)</td> <td>40.0</td> <td>40.0</td> <td>67.0</td> </tr> <tr> <td>Maximum additional charge C(kg)</td> <td>30.5</td> <td>27.0</td> <td>45.0</td> </tr> </table> <p>(b) Calculation of the additional charge for the air conditioner system in the field. The additional charge (F kg) is calculated as follows. F should be round up to 0.1 digital, like 10.52→10.6kg.Yet, if F results bigger than C, the maximum additional charge is C. $F(\text{kg})=(0.2 \times L_d)+(0.12 \times L_e)+(0.06 \times L_f)+(0.024 \times L_g)+D$ Where L_d(m) : Length of liquid pipe sized Φ15.88 L_e(m) : Length of liquid pipe sized Φ12.7 L_f(m) : Length of liquid pipe sized Φ9.52 L_g(m) : Length of liquid pipe sized Φ6.35 D(kg) : Additional charge of refrigerant required by the total capacity of AHU units in the refrigerant system.</p> <table border="1"> <tr> <td>Total capacity of AHU units connected</td> <td>~161</td> <td>161~330</td> <td>331~480</td> <td>481~500</td> </tr> <tr> <td>D(kg)</td> <td>1.5</td> <td>2.0</td> <td>2.5</td> <td>3.0</td> </tr> </table>	PU(H)Y-YGM	P250,300,350	P400	P450,500	Original charge A(kg)	9.5	13.0	22.0	Maximum total charge B(kg)	40.0	40.0	67.0	Maximum additional charge C(kg)	30.5	27.0	45.0	Total capacity of AHU units connected	~161	161~330	331~480	481~500	D(kg)	1.5	2.0	2.5
PU(H)Y-YGM	P250,300,350	P400	P450,500																							
Original charge A(kg)	9.5	13.0	22.0																							
Maximum total charge B(kg)	40.0	40.0	67.0																							
Maximum additional charge C(kg)	30.5	27.0	45.0																							
Total capacity of AHU units connected	~161	161~330	331~480	481~500																						
D(kg)	1.5	2.0	2.5	3.0																						

3. Product configuration

(1) Series configuration

Several types of controllers to accommodate different AHU capacities are available.

Select the appropriate controller.

Model name		PAC-AH125M-H	PAC-AH140M-H	PAC-AH250M-H		
Cooling	Max. capacity (kW)	11.2	14.0	16.0	22.4	28.0
	Min. capacity (kW)	9.0	11.2	14.0	16.0	22.4
Heating	Max. capacity (kW)	12.5	16.0	18.0	25.0	31.5
	Min. capacity (kW)	10.0	12.5	16.0	18.0	25.0
Reference air flow rate (m ³ /h)		2000	2500	3000	4000	5000
Unit capacity		100	125	140	200	250

- * Calculate the capacity of connectable indoor units using the “Unit capacity” in the table above.
The Unit capacity is set at the model name at factory shipment. Change the Unit capacity to the appropriate value for the selected controller using the switch on the controller board. When it is needed, refer to the installation manual for how to change the Unit capacity.

(2) Controller components

Name		Usage
Controller	Controller board	For operation control
	Transformer	For controller board
	Terminal block	For power source, for external I/O, for internal and external communication, for remote controller, and for thermistor
	Connector	For remote controller and for level input switch
	Relay	For operation display and for error display
LEV-kit		Electronic linear expans. valve
Thermistor		For detection of suction air temperature, discharge temperature, liquid pipe temperature, and gas pipe temperature
Clip		For mounting suction air and discharge air temperature thermistor
Insulation		For insulating liquid pipe and gas pipe thermistor
Tie band		For fixing liquid pipe and gas pipe thermistor
Tube		For fixing wiring
Installation manual		-

(3) Major specifications

Power supply		208~240V 50/60Hz
External dimension (mm)		382(430)×326×117(132) The figure in () indicates mounting's.
Net weight (kg)		7
External finish(Munsel No.)		5Y 8/1
IP-class		IP24
Remote controller temperature setting range	Cooling	14~30°C
	Heating	17~28°C
Operation	Operation by optional remote controller	Press ON/OFF button on the remote controller to start/stop the operation.
	Operation by external input*	Connect the field-installed external thermostat (ON/OFF) to the external input (ON/OFF) to start the operation when the external thermo is ON, and stop the operation when it is OFF.
	Interlock operation with AHU fan	Interlock setting between the error stop of AHU fan and the external input ON/OFF must be made to close the LEV of AHU heat exchanger when AHU fan makes an error stop. Refer to section 5 for details.
Temperature control	Temperature control by optional remote controller	<p>Discharge air temperature control or suction/room air temperature control can be chosen by changing the switch on control board and by changing the position of attached thermistor.</p> <p>In controlling the discharge air temperature, the capacity is controlled so that detection temperature of the thermistor installed in an outlet of AHU reaches the set temperature by remote controller.</p> <p>In controlling the suction/room air temperature, the capacity is controlled so that thermostat becomes OFF if detection temperature of the thermistor installed in an inlet of AHU or the room reaches the set temperature by remote controller.</p>

Temperature control	Temperature control by optional remote controller	<p>(i) Thermostat condition in controlling the discharge air temperature</p> <p>TH21: Discharge air temperature TH24: Suction air temperature To : The preset temperature on the remote controller *The value shown with a square in the table below can be changed by a dip-switch.</p> <p>Cooling</p> <table border="1" data-bbox="730 465 1493 757"> <tr> <td>The range of "To"</td> <td>14~30°C</td> </tr> <tr> <td>Thermostat OFF a) or b) or c)</td> <td>a) TH24 < To b) TH24 < 14°C c) TH21 < To - 2°C is continued for 10 minutes.</td> </tr> <tr> <td>Thermostat ON a) & b) & c) & d)</td> <td>a) TH24 > To + 1°C b) TH24 > 15°C c) TH21 > To + 1°C d) It passes from thermostat OFF for 3 minutes.</td> </tr> </table> <p>Heating</p> <table border="1" data-bbox="730 824 1493 1115"> <tr> <td>The range of "To"</td> <td>17~28°C</td> </tr> <tr> <td>Thermostat OFF a) or b) or c)</td> <td>a) TH24 > To b) TH24 > 15°C c) TH21 > To + 3°C is continued for 10 minutes.</td> </tr> <tr> <td>Thermostat ON a) & b) & c) & d)</td> <td>a) TH24 < To - 1°C b) TH24 < 14°C c) TH21 < To - 1°C d) It passes from thermostat OFF for 3 minutes.</td> </tr> </table> <p>(ii) Thermostat condition in controlling the suction/return air temperature</p> <p>TH21: Suction/Return air temperature TH24: Suction air temperature To : The preset temperature on the remote controller *The value shown with a square in the table below can be changed by a dip-switch.</p> <p>Cooling</p> <table border="1" data-bbox="730 1435 1493 1693"> <tr> <td>The range of "To"</td> <td>14~30°C</td> </tr> <tr> <td>Thermostat OFF a) or b)</td> <td>a) TH24 < 20°C b) TH21 < To - 0.5°C</td> </tr> <tr> <td>Thermostat ON a) & b) & c)</td> <td>a) TH24 > 21°C b) TH21 > To + 0.5°C c) It passes from thermostat OFF for 3 minutes.</td> </tr> </table> <p>Heating</p> <table border="1" data-bbox="730 1760 1493 1888"> <tr> <td>The range of "To"</td> <td>17~28°C</td> </tr> <tr> <td>Thermostat OFF</td> <td>a) TH24 > 21°C b) TH21 > To</td> </tr> </table>	The range of "To"	14~30°C	Thermostat OFF a) or b) or c)	a) TH24 < To b) TH24 < 14°C c) TH21 < To - 2°C is continued for 10 minutes.	Thermostat ON a) & b) & c) & d)	a) TH24 > To + 1°C b) TH24 > 15°C c) TH21 > To + 1°C d) It passes from thermostat OFF for 3 minutes.	The range of "To"	17~28°C	Thermostat OFF a) or b) or c)	a) TH24 > To b) TH24 > 15°C c) TH21 > To + 3°C is continued for 10 minutes.	Thermostat ON a) & b) & c) & d)	a) TH24 < To - 1°C b) TH24 < 14°C c) TH21 < To - 1°C d) It passes from thermostat OFF for 3 minutes.	The range of "To"	14~30°C	Thermostat OFF a) or b)	a) TH24 < 20°C b) TH21 < To - 0.5°C	Thermostat ON a) & b) & c)	a) TH24 > 21°C b) TH21 > To + 0.5°C c) It passes from thermostat OFF for 3 minutes.	The range of "To"	17~28°C	Thermostat OFF	a) TH24 > 21°C b) TH21 > To
The range of "To"	14~30°C																							
Thermostat OFF a) or b) or c)	a) TH24 < To b) TH24 < 14°C c) TH21 < To - 2°C is continued for 10 minutes.																							
Thermostat ON a) & b) & c) & d)	a) TH24 > To + 1°C b) TH24 > 15°C c) TH21 > To + 1°C d) It passes from thermostat OFF for 3 minutes.																							
The range of "To"	17~28°C																							
Thermostat OFF a) or b) or c)	a) TH24 > To b) TH24 > 15°C c) TH21 > To + 3°C is continued for 10 minutes.																							
Thermostat ON a) & b) & c) & d)	a) TH24 < To - 1°C b) TH24 < 14°C c) TH21 < To - 1°C d) It passes from thermostat OFF for 3 minutes.																							
The range of "To"	14~30°C																							
Thermostat OFF a) or b)	a) TH24 < 20°C b) TH21 < To - 0.5°C																							
Thermostat ON a) & b) & c)	a) TH24 > 21°C b) TH21 > To + 0.5°C c) It passes from thermostat OFF for 3 minutes.																							
The range of "To"	17~28°C																							
Thermostat OFF	a) TH24 > 21°C b) TH21 > To																							

	Temperature control by external thermostat	Connect the field-installed external thermostat (ON/OFF) to the external input (ON/OFF) to start the operation when the external thermo is ON, and stop the operation when it is OFF. The thermostat will be turned off when the suction air temperature thermistor reading reaches the preset temperature on the remote controller. Refer to section 5 for details. * A remote controller is necessary for the operation mode switching.
Protection function	Freezing prevention	After 16-minute or more cooling operation, and when 1°C or less of the thermistor detection temperature for liquid pipe is detected for 3 minutes in a row, the linear expansion valve will be closed to prevent freezing. The operation will be normal when either of the following conditions is met. - When 3 minutes have passed after 10°C or more of the thermistor detection temperature for liquid pipe is detected. - When 6 minutes have passed after the expansion valve was closed to prevent freezing.
	Sensor failure	If a short or an open of the thermistor is detected during operation, the error will affect the LEV, and it will be closed.
	Communication error	If the addresses overlap or the transmission line is not connected properly, the error will affect the LEV, and it will be closed.
	Other types of error	If the outdoor unit in the system has a problem, it will affect the entire system, and the compressor will stop.

Switch function	Thermostat control	a) Change of discharge or suction air temperature control																															
		Dip switch	Thermostat control	Remarks																													
		SW7-2																															
		OFF	Suction / return	—																													
		ON	Discharge	Initial setting																													
		b)TH21																															
		Detection temperature of the thermistor TH21 is replaced to the value below by Dip switch on the control board.																															
		<table border="1"> <thead> <tr> <th colspan="2">Dip switch</th> <th colspan="2">Detection temperature</th> <th rowspan="2">Remarks</th> </tr> <tr> <th>SW1-2</th> <th>SW1-3</th> <th>Cooling</th> <th>Heating</th> </tr> </thead> <tbody> <tr> <td>OFF</td> <td>OFF</td> <td>TH21</td> <td>TH21</td> <td>Initial setting</td> </tr> <tr> <td>ON</td> <td>OFF</td> <td>TH21-1</td> <td>TH21+1</td> <td>—</td> </tr> <tr> <td>OFF</td> <td>ON</td> <td>TH21-2</td> <td>TH21+2</td> <td>—</td> </tr> <tr> <td>ON</td> <td>ON</td> <td>TH21-3</td> <td>TH21+3</td> <td>—</td> </tr> </tbody> </table>			Dip switch		Detection temperature		Remarks	SW1-2	SW1-3	Cooling	Heating	OFF	OFF	TH21	TH21	Initial setting	ON	OFF	TH21-1	TH21+1	—	OFF	ON	TH21-2	TH21+2	—	ON	ON	TH21-3	TH21+3	—
Dip switch		Detection temperature		Remarks																													
SW1-2	SW1-3	Cooling	Heating																														
OFF	OFF	TH21	TH21	Initial setting																													
ON	OFF	TH21-1	TH21+1	—																													
OFF	ON	TH21-2	TH21+2	—																													
ON	ON	TH21-3	TH21+3	—																													
		c)TH24																															
		i) Discharge air temperature control																															
		<Cooling>																															
		<table border="1"> <thead> <tr> <th>Dip switch</th> <th colspan="2">Thermostat condition of TH24</th> <th rowspan="2">Remarks</th> </tr> <tr> <th>SW3-10</th> <th>Thermo-OFF</th> <th>Thermo-ON</th> </tr> </thead> <tbody> <tr> <td>OFF</td> <td>14°C</td> <td>15°C</td> <td>Initial setting</td> </tr> <tr> <td>ON</td> <td>20°C</td> <td>21°C</td> <td>—</td> </tr> </tbody> </table>			Dip switch	Thermostat condition of TH24		Remarks	SW3-10	Thermo-OFF	Thermo-ON	OFF	14°C	15°C	Initial setting	ON	20°C	21°C	—														
Dip switch	Thermostat condition of TH24		Remarks																														
SW3-10	Thermo-OFF	Thermo-ON																															
OFF	14°C	15°C	Initial setting																														
ON	20°C	21°C	—																														
		<Heating>																															
		<table border="1"> <thead> <tr> <th>Dip switch</th> <th colspan="2">Thermostat condition of TH24</th> <th rowspan="2">Remarks</th> </tr> <tr> <th>SW3-8</th> <th>Thermo-OFF</th> <th>Thermo-ON</th> </tr> </thead> <tbody> <tr> <td>OFF</td> <td>10°C</td> <td>9°C</td> <td>—</td> </tr> <tr> <td>ON</td> <td>15°C</td> <td>14°C</td> <td>Initial setting</td> </tr> </tbody> </table>			Dip switch	Thermostat condition of TH24		Remarks	SW3-8	Thermo-OFF	Thermo-ON	OFF	10°C	9°C	—	ON	15°C	14°C	Initial setting														
Dip switch	Thermostat condition of TH24		Remarks																														
SW3-8	Thermo-OFF	Thermo-ON																															
OFF	10°C	9°C	—																														
ON	15°C	14°C	Initial setting																														
		ii)Suction/return air temperature control																															
		<Cooling>																															
		<table border="1"> <thead> <tr> <th>Dip switch</th> <th colspan="2">Thermostat condition of TH24</th> <th rowspan="2">Remarks</th> </tr> <tr> <th>SW1-8</th> <th>Thermo-OFF</th> <th>Thermo-ON</th> </tr> </thead> <tbody> <tr> <td>OFF</td> <td>20°C</td> <td>21°C</td> <td>Initial setting</td> </tr> <tr> <td>ON</td> <td>15°C</td> <td>16°C</td> <td>—</td> </tr> </tbody> </table>			Dip switch	Thermostat condition of TH24		Remarks	SW1-8	Thermo-OFF	Thermo-ON	OFF	20°C	21°C	Initial setting	ON	15°C	16°C	—														
Dip switch	Thermostat condition of TH24		Remarks																														
SW1-8	Thermo-OFF	Thermo-ON																															
OFF	20°C	21°C	Initial setting																														
ON	15°C	16°C	—																														
		<Heating>																															
		<table border="1"> <thead> <tr> <th>Dip switch</th> <th colspan="2">Thermostat condition of TH24</th> <th rowspan="2">Remarks</th> </tr> <tr> <th>SW3-8</th> <th>Thermo-OFF</th> <th>Thermo-ON</th> </tr> </thead> <tbody> <tr> <td>OFF</td> <td>10°C</td> <td>9°C</td> <td>—</td> </tr> <tr> <td>ON</td> <td>15°C</td> <td>14°C</td> <td>Initial setting</td> </tr> </tbody> </table>			Dip switch	Thermostat condition of TH24		Remarks	SW3-8	Thermo-OFF	Thermo-ON	OFF	10°C	9°C	—	ON	15°C	14°C	Initial setting														
Dip switch	Thermostat condition of TH24		Remarks																														
SW3-8	Thermo-OFF	Thermo-ON																															
OFF	10°C	9°C	—																														
ON	15°C	14°C	Initial setting																														

d) Dip-switch for function

In a table shown below, the gray part shows "At delivery".

i) Discharge air temperature control

SW1

No.	Function	Operation by switch	
		ON	OFF
1	Thermistor< suction temperature> position	Remote controller	TH21
2	Replace of TH21 Cooling: TH21-a Heating: TH21+a	2 / 3 OFF/OFF: a=0 ON / OFF: a=1 OFF / ON: a=2 ON / ON: a=3	
3			
4	NOT available	N/A	Fix
5	Remote indication switching	Thermostat ON signal	Fan output
6	NOT available	N/A	Fix
7	NOT available	N/A	Fix
8	NOT available	N/A	Fix
9	Auto reset function	Effective	Not effective
10	Power ON/OFF	Effective	Not effective

SW3

No.	Function	Operation by switch	
		ON	OFF
1	Heat pump /Cooling only	Cooling only	Heat pump
2	NOT available	N/A	Fix
3	NOT available	N/A	Fix
4	Fan in defrosting	Fan ON	Fan OFF
5	NOT available	N/A	Fix
6	NOT available	N/A	Fix
7	NOT available	N/A	Fix
8	Thermostat by TH24 in heating	15°C-OFF 14°C-ON	10°C-OFF 9°C-ON
9	NOT available	Fix	N/A
10	Thermostat by TH24 in cooling	20°C-OFF 21°C-ON	14°C-OFF 15°C-ON

ii) Suction/return air temperature control

SW1

No.	Function	Operation by switch	
		ON	OFF
1	Thermistor< suction temperature> position	Remote controller	TH21
2	Replace of TH21 Cooling: TH21-a Heating: TH21+a	2 / 3 OFF/OFF: a=0 ON / OFF: a=1 OFF / ON: a=2 ON / ON: a=3	
3			
4	NOT available	N/A	Fix
5	Remote indication switching	Thermostat ON signal indication	Fan output indication
6	NOT available	N/A	Fix
7	NOT available	N/A	Fix
8	Thermostat by TH24 in cooling	15°C-OFF 16°C-ON	20°C-OFF 21°C-ON
9	Auto reset function	Effective	Not effective
10	Power ON/OFF	Effective	Not effective

SW3

No.	Function	Operation by switch	
		ON	OFF
1	Heat pump /Cooling only	Cooling only	Heat pump
2	NOT available	N/A	Fix
3	NOT available	N/A	Fix
4	Fan in defrosting	Fan ON	Fan OFF
5	NOT available	N/A	Fix
6	NOT available	N/A	Fix
7	NOT available	N/A	Fix
8	NOT available	Fix	N/A
9	NOT available	Fix	N/A
10	NOT available	Fix	N/A

* Default setting (operation mode setting or temperature setting) with an optional remote controller must be made when an external input is used.

4. Requirements on AHU design

(1) Design method of heat exchanger

	Model name	PAC-AH125M-H		PAC-AH140M-H		PAC-AH250M-H	
Common part	Unit capacity	100	125	140	200	250	
	Reference air flow rate (m ³ /h)	2000	2500	3000	4000	5000	
	Min. volume inside heat exchanger tube (cm ³)	1500	1900	2150	3000	3750	
	Max. volume inside heat exchanger tube (cm ³)	2850	3550	4050	5700	7100	
Cooling	Max. capacity (kW)	11.2	14.0	16.0	22.4	28.0	
	Min. capacity (kW)	9.0	11.2	14.0	16.0	22.4	
	Standard number of paths (Heat exchanger tube size Φ9.52)	4~5	4~5	5~6	6~10	8~10	
	Pressure drop of the refrigerant in heat exchanger	Max. 0.03MPa					
	LEV inlet temperature	25°C					
	Evaporating temperature	8.5°C					
	SH	5K					
	Evaporator outlet Temperature	13.5°C					
Heating	Evaporator suction air temperature	27°CDB/19°CWB					
	Max. capacity (kW)	12.5	16.0	18.0	25.0	31.5	
	Min. capacity (kW)	10.0	12.5	16.0	18.0	25.0	
	Condensing temperature =TC	Choose TC satisfying a condenser design condition among chart below depending on unit size. In the case of using a heat recovery, choose TC=48°C as the suction temperature of heat exchanger may become 10°C or more even if outdoor temperature is 0°C.					

Outdoor temperature 0°CDB/-2.9°CWB

P100	800	1200	1600	2000	2400
P125	1000	1500	2000	2500	3000
P140	1120	1680	2240	2800	3360
P200	1600	2400	3200	4000	4800
P250	2000	3000	4000	5000	6000
Unit size	Air flow rate (GMH)				

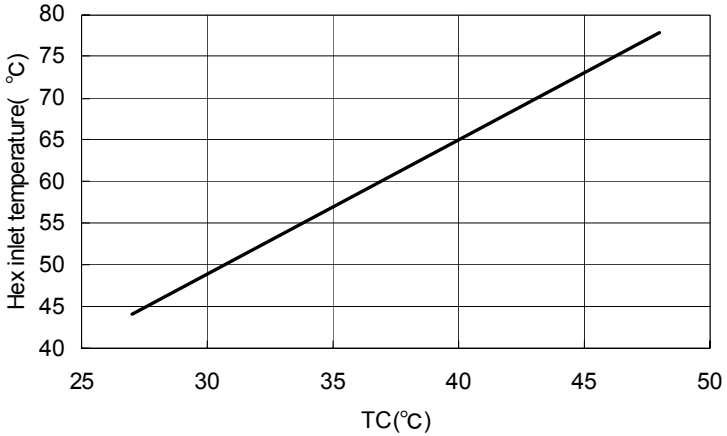
Heating	HEX inlet temperature	Coose HEX inlet temperature from chart below depending on TC. 
	SC	15K
	Condensor outlet temperature	TC-15
	Condensor suction air temperature	0°CDB / -2.9°CWB

Calculate the capacity of connectable AHU units using the “Unit capacity” in the table above.

(2) Heat exchanger manufacturing

Design pressure	4.15 MPa
Evaporator burst pressure Compressive strength	The compressive strength of the evaporator and of other pipes must exceed 12.45MPa. Insufficient withstand pressure may cause the pipes to crack and result in gas leakage.
Contamination control	Clean the heat exchanger with detergent to make the allowable level of contamination per unit length of the heat exchanger tube of the following values or less on the assumption that the heat exchanger tube size is $\Phi 9.52$. Do not use chlorinated detergent. Do not leave flux. Allowable level of contamination may cause the compressor not to function properly. Contamination amount: residual water amount 0.6 mg/m or less, residual oil amount 0.5 mg/m or less, amount of solid contaminants 1.8 mg/m or less

(3) Installation conditions of AHU controller

Installation site	<ul style="list-style-type: none"> - Avoid locations in direct sunlight. - Avoid locations exposed to steam or oil vapor. - Avoid locations where combustible gas may leak, settle or generated - Avoid installation near machines emitting high-frequency waves. - Avoid places where acidic solutions are frequency waves. - Avoid places where sulfur-based or other sprays are frequently used. - Avoid places where vibration may occur.
Ambient temperature	-20~43°C
Ambient humidity	Relative humidity of 95% or less (No dew condensation is allowed)
Installation angle	Vertical installation

(4) Cautions for installing LEV-kit

Installation environment	Avoid locations in direct sunlight.
Installation angle	Install the motor above the horizontal.
Pipe size	Φ9.52 (Brazing) Use two LEVs when installing AH250. Connect two LEVs in parallel, and connect them to the appropriate refrigerant pipe according to the unit capacity.
Caution on brazing	LEV can withstand only up to 120°C. Cool the LEV while brazing.
Wire connection	<ul style="list-style-type: none"> - Connect the wire according to the wire color code to avoid miswiring. For AH250, connect two wires to the same terminal. - Do not strain the power supply wires. - Be careful with the plate edge not to damage the wire. - The wire can withstand only up to 105°C. Keep the wire away from high-temperature part. - Bend the wire into "U" shape to prevent water from running down the wire and from dripping on the electrical components or the LEV.

(5) Cautions for installing thermistor

Installation site	<ul style="list-style-type: none"> - Install the pipe thermistor properly so that it can accurately measure the pipe temperature. Protect it with the insulation material so that it is not affected by the temperature at other places. - Install the liquid thermistor sensor at the evaporator inlet where the lowest temperature is found, as the thermistor is used to prevent freezing. - Install the gas pipe thermistor at the junction of the evaporator outlet. - Install the suction air temperature thermistor at a place where the average temperature of suction air into the evaporator can be measured.
Wire connection	<ul style="list-style-type: none"> - Connect the wire according to the terminal number to avoid miswiring. - Do not strain the power supply wires. - Be careful with the plate edge not to damage the wire. - The wire can withstand only up to 105°C. Keep the wire away from high-temperature part. - Bend the wire into "U" shape to prevent water from running down the wire and from dripping on the electrical components or the thermistor.

(6) Other cautions

- The refrigerant temperature inside the evaporator may become 0°C. Note that dew condensation on AHU main body or on the refrigerant pipe may occur.
- Drain the AHU properly.
The temperature of AHU evaporator will drop and dew may condense on the AHU main body, if the LEV of AHU does not close due to malfunction in a system with one outdoor unit connected to a AHU controller, and if the AHU stopped and the other AHUs are in operation. Take appropriate measures against dew condensation to avoid serious damage to the unit.
- When a heater for heating operation is built-in and when both of the heater for heating operation and the heat exchanger are operated, the operation must be conducted within the inlet temperature range of the heat exchanger.
- Install an air filter on the heat exchanger.
- Interlock the unit with the fan to prevent the refrigerant system from running when the fan stopped.
- In a system with one outdoor unit connected to a AHU controller, the LEV of AHU will slightly open in heating operation to prevent the refrigerant from accumulating inside the AHU heat exchanger, and the temperature of the AHU heat exchanger will slightly rise.
- In a system with one outdoor unit to which some AHU controllers are connected, the LEV will be temporarily open in heating operation to run the outdoor unit in defrost operation. In this case, low-temperature refrigerant will run inside the AHU heat exchanger, and the heating capacity

of AHU which is running heating operation using the heater for heating operation will temporarily drop.

- In controlling the suction/return air temperature, capacity control is affected by the outdoor temperature. When the outdoor temperature drops, the discharge temperature also drops. Take proper measures to control the room temperature, to select the outlet position, and to prevent dew condensation.

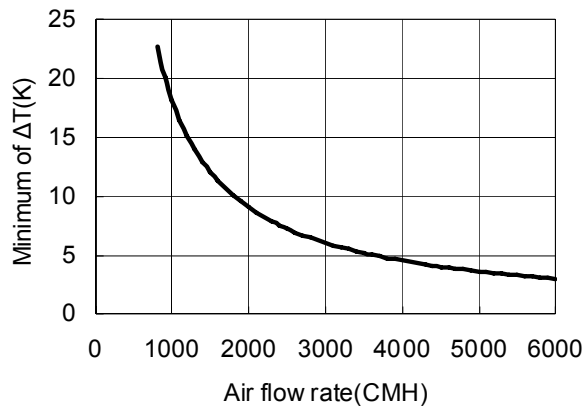

- In controlling the discharge air temperature, check the discharge air temperature of the low load capacity in middle season, because the thermostat may repeat ON/OFF.

The targeted minimum capacity is 6kW. The minimum ΔT , which is the temperature difference between the inlet air temperature of the heat exchanger and discharge air temperature in heating mode, is shown as below chart. In cooling mode, ΔT is different depending on the SHF (As shown below, when SHF is 1, this is the ΔT at heating).

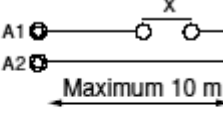
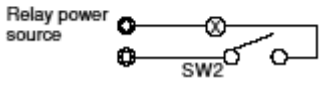
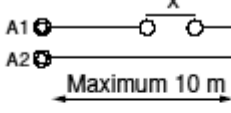
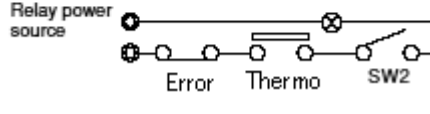

5. Requirements on interface with controller

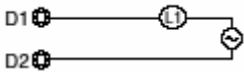
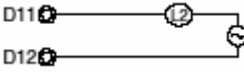
Item	Connection circuit
Operation	<p>■ Operation contact specifications</p>  <p>SW1: Operation command (field supply) Minimum applicable load DC5V, 1mA</p>
	<p>■ Use a relay when the electrical wire exceeds 10m.</p>  <p>X: Relay(field supply) Minimum applicable load DC5V, 1mA</p>  <p>SW2: Operation command (field supply)</p>
	<p>■ Interlock operation with fan error and connection example of field-installed thermostat Interlock the unit so that the unit stops when an error occurs on the fan (field supply).</p>  <p>X: Relay(field supply) Minimum applicable load DC5V, 1mA</p>  <p>SW2: Operation command (field supply) Error: Error of fan sections (field supply) Thermo: Thermistor (field supply)</p>

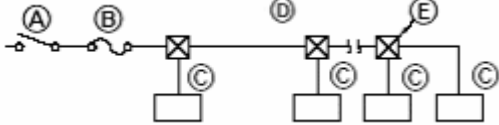
<p>Operation signal</p>	 <p>L1: Operation display lamp (field supply) Display power source: DC30V 1A, AC100V/200V 1A</p>
<p>Error signal</p>	 <p>L2: Error display lamp (field supply) Display power source: DC30V 1A, AC100V/200V 1A</p> <p>If error resets (stop operation) and restart operations are repeatedly performed, the Compressor may be damaged seriously. Install an error lamp, and contact the service firm or the dealer when an error occurs. Installation of the remote controller is recommended so that the error details can be checked.</p>
<p>Fan signal</p>	 <p>X: Relay(field supply) AC200V 1A,</p> <p>A fan control signal is output. It is usually the ON output at the time of operating, but it is the OFF output in defrosting.</p> <ul style="list-style-type: none"> -Be careful to miscarriage lines because over AC200V is impressed in ON. -When the dip-switch SW3-4 on the control board is ON, the fan operates in defrosting also. In this case, be careful of the cold wind of AHU or the freezing of a humidifier. -When the switch SWE on the control board is turned on, the fan signal is always ON.
<p>Defrost signal</p>	 <p>X: Relay(field supply) AC200V 1A,</p> <p>A defrost signal is output in defrosting. Be careful to miscarriage lines because over AC200V is impressed in ON.</p>
<p>Electrical wiring</p>	 <p>(A) Switch 16 A (B) Overcurrent protection 16 A (C) AHU controller (D) Total operating current be less than 16 A (E) Pull box</p> <ul style="list-style-type: none"> - Power supply cords of appliances shall not be lighter than design 245 IEC 57 or 227 IEC 57. - A switch with at least 3mm contact separation in each pole shall be provided by the Air conditioner installation. - The diameter of the power supply wire to the AHU controller must be 1.5mm² or larger. - Use an earth leakage breaker with a sensitivity of 30 mA 0.1s or less. - Use a separate wire for AHU's main circuit from the circuit shown above. Select the appropriate wire or the protection device on site, according to the AHU specifications.
<p>Transmission cables</p>	<ul style="list-style-type: none"> - Type of cable : Shielding wire (2-core) CVVS or CPEVS or MVVS - Cable diameter : 1.25mm²
<p>M-NET Remote controller cables</p>	<ul style="list-style-type: none"> - Type of cable : Sheathed wire 2-core cable(unshielded) CVV - Cable diameter: 0.3~1.25mm² (0.75~1.25mm² : connected with simple remote controller) <p>* When the cable exceeded 10m, use cables with the same specification as transmission cables.</p>
<p>MA Remote controller cables</p>	<ul style="list-style-type: none"> - Type of cable : Sheathed wire 2-core cable(unshielded) CVV - Cable diameter: 0.3~1.25mm² (0.75~1.25mm² : connected with simple remote controller) - Max length : 200m

- CVVS, MVVS : PVC insulated PVC jacketed shielded control cable
- CPEVS : PE insulated PVC jacketed shielded communication cable
- CVV : PV insulated PVC sheathed control cable

6. Related cautions

(1) Installation work

- Secure enough service space for replacement of the LEV and the thermistor. After an AHU controller is installed, address setting and unit capacity setting on the controller board switch is necessary. Refer to the installation manual for the setting method.
- Refer to the outdoor unit installation manual or the data book for installation of the outdoor unit.

(2) Test run

- Turn on the main power of the unit at least 12 hours before test run to power the crankcase heater. Insufficient powering time may result in compressor damage.
- As the temperature setting and the operation mode setting are made at initial setting, a remote controller is necessary. Remove the remote controller after making the initial settings if it is not used. In case of PAR21MAA, remove the remote controller after turning off the power of the indoor and outdoor units. In case of PAR-27MEA, remove it after deleting the address of the remote controller.

(Refer to the installation manual for remote controller for more details.)

(3) Operation control

- Remove the connector inside the AHU controller when a local remote controller is used. When the connector is connected, the controller will be in the remote operation mode, and the operation by the local remote controller will be prohibited.
- If the error lamp lights or the error display appears on the remote controller, do not reset an error by yourself. Contact the service firm or the dealer.
- Refer to the data book for system controller when using the system controller.

(4) Service

- Regular maintenance is required to prolong the life of the units. It is recommended that the maintenance contract be concluded with a maintenance firm.

(5) PAC-AH M-G type

- PAC-AH M-H type can be changed to PAC-AH M-G type by setting the following switch. New functions, thermostat control etc, can not be available by PAC-AH M-G type except for the fan signal.

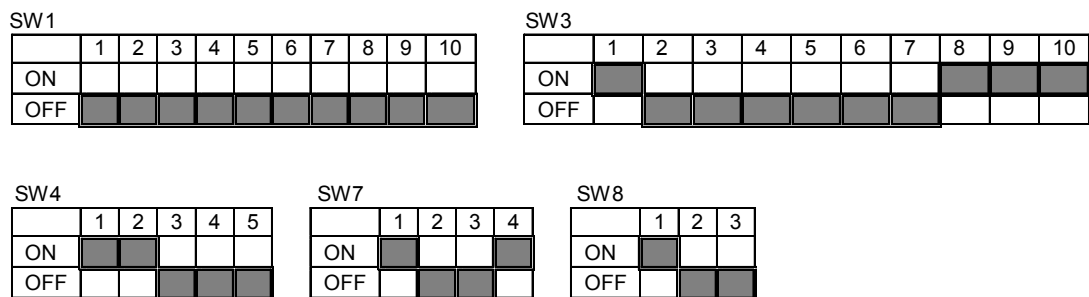

7. Warranty

- Specifications of AHU and compatibility with regulations must be confirmed by your company.
- Selection of an appropriate AHU (with appropriate specifications to match those of units connected to the AHU such as configuration, dimension, life-span, vibration, noise level, or features) must be made by your company.
- Mitsubishi Electric shall not be liable for any damage to the entire system or the AHU main body caused by connected AHU with wrong specification or wrong usage of AHU.
- Mitsubishi Electric shall not be liable for any damage to the outdoor units caused by AHU damage.

External Dimension

PAC-AH125/140/250M-H

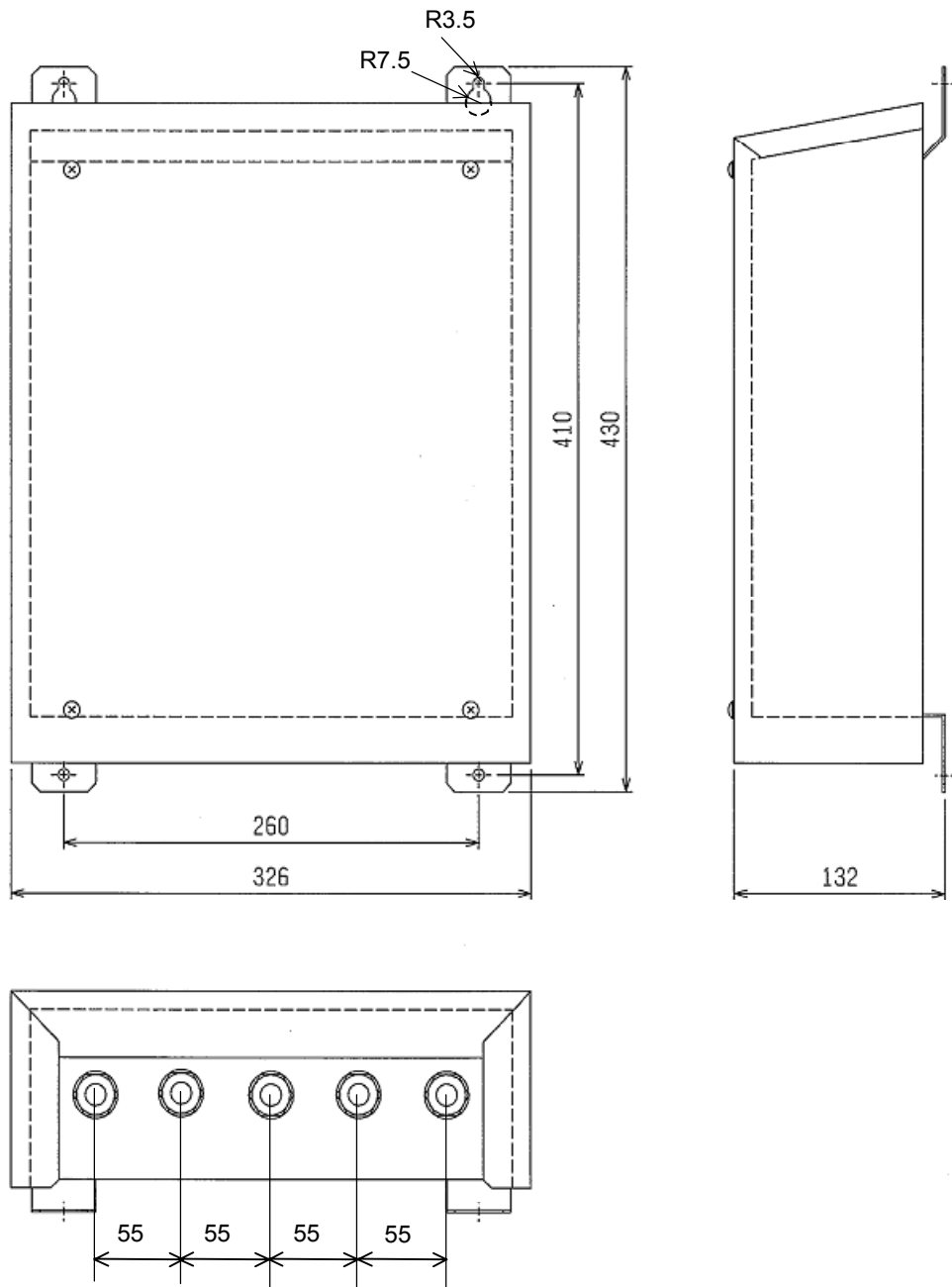

Electrical Wiring Diagram

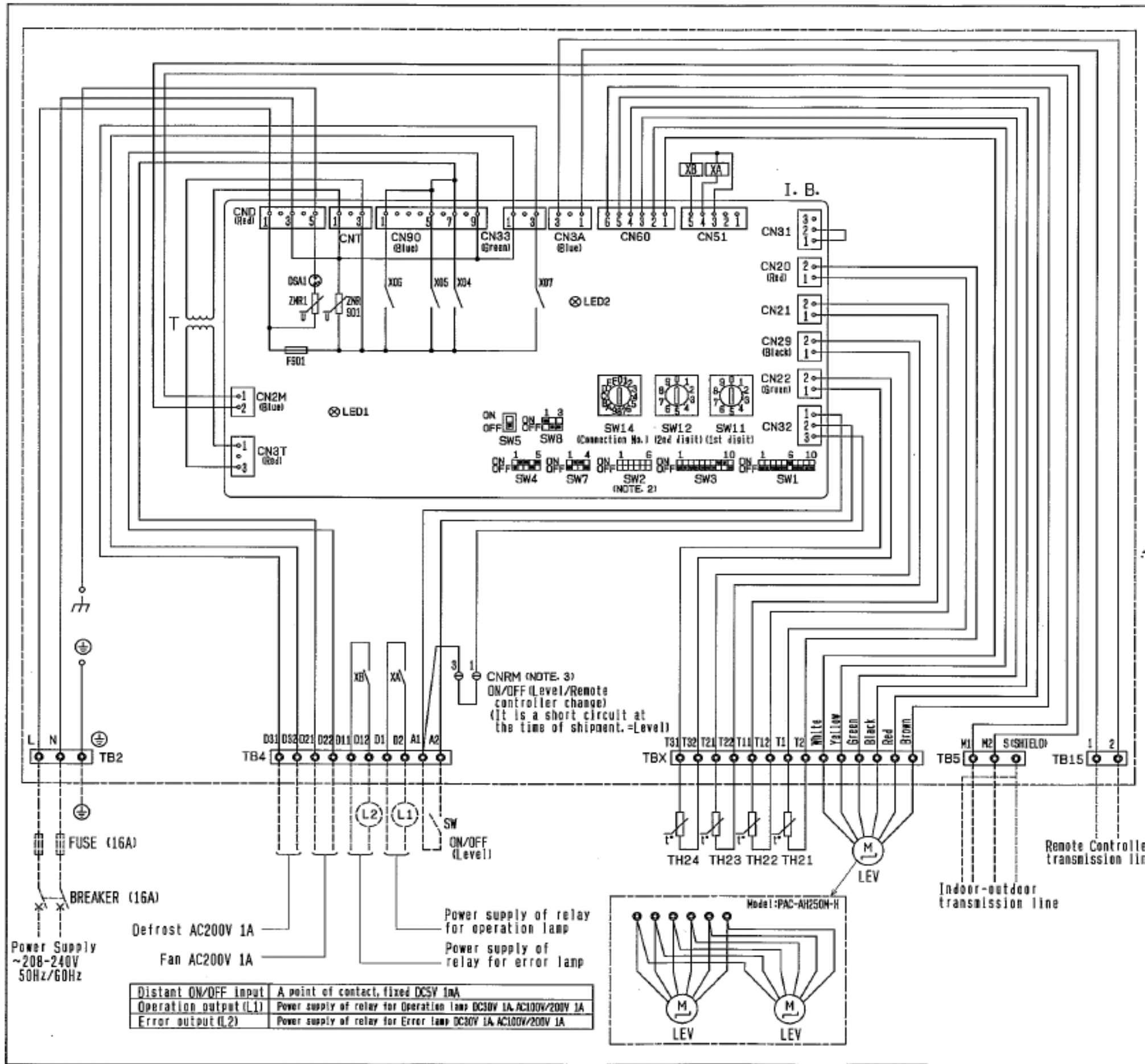

NOTE
1. Address switch and branch port switch setting
 For the address setting method, refer to the address setting item of the installation manual.
2. Initial setting of SW2
 Always operate in the power-off state. For the SW2 setting method, refer to the unit size setting item of the installation manual.
 SW2 at delivery

MODELS	SW2	MODELS	SW2
PAC-AH125M-H	ON 1 6 OFF	PAC-AH250M-H	ON 1 6 OFF
PAC-AH140M-H	ON 1 6 OFF		

3. Initial setting of operation mode
 A remote controller is required to perform initial setting, when the controller board is exchanged. Remove the connector "CNRM" and set the operation mode to cooling mode. Connect the connector as it was, when the remote controller is NOT used.

4. Sign explanation
 (thick dashedline): Local wiring
 ⊕: Connector, ⊙: Terminal bed

SYMBOL EXPLANATION

Symbol	Name
I.B.	Indoor controller board
F901	Fuse (AC250V 6.3A)
ZNR1, 901	Varistor
LED1	LED (Power supply)
LED2	LED (Remote controller supply)
SW1	Switch (for mode selection)
SW2	Switch (for capacity code)
SW3	Switch (for mode selection)
SW4	Switch (for model selection)
SW5	Switch (for voltage selection)
SW7	Switch (for mode selection)
SW8	Switch (for mode selection)
SW11	Switch (1st digit address set)
SW12	Switch (2nd digit address set)
SW14	Switch (connection No. set)
X04-X07	Aux. relay
T	Transformer
TB2	Power source terminal bed
TB4	Terminal bed (Distant ON/OFF input, Level, Operation output, Error output, Fan output, Defrost output)
TB5	Transmission terminal bed
TB15	Transmission terminal bed
TH21	Thermistor (AHU inlet air temp. detection)
TH22	Thermistor (AHU pipe temp. detection/liquid)
TH23	Thermistor (AHU pipe temp. detection/gas)
TH24	Thermistor (AHU outlet air temp. detection)
TBX	Terminal bed (Thermistor, LEV)
LEV	Electronic linear expansion valve
SW	Switch (Distant ON/OFF input)
L1	Lamp (Operation output)
L2	Lamp (Error output)

Distant ON/OFF input	A point of contact, fixed DC5V 1mA
Operation output (L1)	Power supply of relay for Operation lamp DC30V 1A, AC100V/200V 1A
Error output (L2)	Power supply of relay for Error lamp DC30V 1A, AC100V/200V 1A