



Midea R134a 50Hz I Flooded type water cooled screw chiller (PCB Control)

Applicable Model:

MWSC340A-FB3	MWSC1080A-FB3
MWSC440A-FB3	MWSC1200A-FB3
MWSC540A-FB3	MWSC1385A-FB3
MWSC690A-FB3	MWSC1620A-FB3
MWSC805A-FB3	MWSC1780A-FB3
MWSC890A-FB3	



Midea reserves the right to discontinue, or change specification or designs at any time without notices and without incurring obligations.

Contents

I. Safety precautions	2
1. Installation safety considerations.....	2
2. Maintenance safety considerations	3
3. Repair safety considerations	4
II. Product	6
1. General Information	6
2. Features.....	8
3. Specifications.....	13
4. Outline dimension	15
5. Refrigeration system.....	16
6. Major system components.....	17
7. Water flow	21
8. Operating range	24
9. Capacity table	25
10. Accessories	31
III. Control	32
1. Control flow chart.....	32
2. Energy adjustment.....	33
3. Start/stop process.....	34
4. Sensors.....	35
5. Parts control.....	36
6. Operation part.....	44
7. Safety protection.....	57
IV. Electrical control.....	59
1. Electrical data	59
2. Electrical components introduction.....	60
3. Electrical parts parameter setting	62
4. Field wiring.....	64
5. Wiring Diagrams	67
V. Installation	76
1. Unit installation.....	76
2. Water pipeline system installation	79
3. Wiring installation.....	85
VI. Commissioning	87
1. Pre start-up	87
2. Start-up	91
VII. Maintenance	93
1. Daily maintenance	93
2. Maintenance	97
VIII. Troubleshooting.....	104
1. Protection items	104
2. Troubleshooting	107
IX. Appendix 1.....	110

Manufacture reserves the right to discontinue, or change at any time, specifications or designs without notices and without incurring obligations.

I. Safety precautions

Before use, read through the operating instructions to ensure proper using. Please keep it well so that the professional technician can refer to it anytime.

1. Installation safety considerations

- (1)** Access to the unit must be reserved to authorized personnel, qualified and trained in monitoring and maintenance. The access limitation device must be installed by the customer (e.g. cut-off, enclosure). After the unit has been received, when it is ready to be installed or reinstalled, and before it is started up, it must be inspected for damage. Check that the refrigerant circuit(s) is (are) intact, especially that no components or pipes have shifted (e.g. following a shock). If in doubt, carry out a leak tightness check and verify with the manufacturer that the circuit integrity has not been impaired. If damage is detected upon receipt, immediately file a claim with the shipping company. Midea strongly recommends employing a specialized company to unload the machine.
- (2)** It is compulsory to wear personal protection equipment. Do not remove the skid or the packaging until the unit is in its final position. These units can be moved with a fork lift truck, as long as the forks are positioned in the right place and direction on the unit.
- (3)** The units can also be lifted with slings, using only the designated lifting points marked on the unit. Use slings with the correct capacity, and always follow the lifting instructions on the certified drawings supplied with the unit. Safety is only guaranteed, if these instructions are carefully followed. If this is not the case, there is a risk of material deterioration and injuries to personnel. Never cover any safety devices. This applies to the relief valve(s) in the refrigerant circuit(s). Ensure that the valves are correctly installed, before operating the unit.
- (4)** The relief valves are designed and installed to ensure protection against overpressure caused by fire. The relief valve must only be removed if the fire risk is fully controlled and after checking that this is allowed by local regulations and authorities. This is the responsibility of the operator. If the unit is installed in a room, the safety valves must be connected to discharge pipes.

Note:

These pipes must be installed in a way that ensures that people and property are not exposed to refrigerant leaks. These fluids may be diffused in the air, but far away from any building air intake, or they must be discharged in a quantity that is appropriate for a suitably absorbing environment. It is recommended to install an indicating device to show if part of the refrigerant has leaked from the valve. The presence of oil at the outlet orifice is a useful indicator that refrigerant has leaked. Keep this orifice clean to ensure that any leaks are obvious. The calibration of a valve that has leaked is generally lower than its original calibration. The new calibration may affect the operating range. To avoid a nuisance tripping or leaks, replace or re-calibrate the valve. Periodic check the relief valves. Ensure good ventilation, as accumulation of refrigerant in an enclosed space can displace oxygen and cause asphyxiation or explosions. Inhalation of high concentrations of vapour is harmful and may cause heart irregularities, unconsciousness, or death. Vapour is heavier than air and reduces the amount of oxygen available for breathing. These products cause eye and skin irritation. Decomposition products are hazardous.

2. Maintenance safety considerations

2.1 Engineers safety consideration

- (1) Engineers working on the electric or refrigeration components must be authorized, trained and fully qualified to do so. All refrigerant circuit repairs must be carried out by a trained person fully qualified to work on these units. He must have been trained and be familiar with the equipment and the installation. All welding operations must be carried out by qualified specialists.
- (2) The insulation must be removed and heat generation must be limited by using a wet cloth. Any manipulation (opening or closing) of a shut-off valve must be carried out by a qualified and authorized engineer. These procedures must be carried out with the unit shut-down.

NOTE: During any handling, maintenance and service operations the engineers working on the unit must be equipped with safety gloves, glasses, shoes and protective clothing.

- (1) Never work on a unit that is still energized.
- (2) Never work on any of the electrical components, until the general power supply to the unit has been cut using the disconnect switch in the control box.
- (3) If any maintenance operations are carried out on the unit, lock the power supply circuit ahead of the machine.
- (4) If the work is interrupted, always ensure that all circuits are still deenergized before resuming the work.

ATTENTION: Even if the unit has been switched off, the power circuit remains energized, unless the unit or circuit disconnect switch is open. Refer to the wiring diagram for further details. Attach appropriate safety labels.

2.2 Operating checks:

Important information regarding the refrigerant used:

- Refrigerant type: R134a
- Periodic inspections for refrigerant leaks may be required depending on local legislation. Please contact your local dealer for more information.
- During the life-time of the system, inspection and tests must be carried out in accordance with national regulations.

2.3 Safety device checks:

- The safety devices and external overpressure devices (safety valves) must be checked on site regularly.
- At least once a year thoroughly inspect the protection devices (valves). If the machine operates in regularly carry out leak tests and immediately repair any leaks.
- Ensure regularly that the vibration levels remain acceptable and close to those at the initial unit start-up. Before opening a refrigerant circuit, purge and consult the pressure gauges.
- Change the refrigerant when there are equipment failures, following related regulations or carry out

a refrigerant analysis in a specialist laboratory.

- If the refrigerant circuit remains open for longer than a day after an intervention (such as a component replacement), the openings must be plugged and the circuit must be charged with nitrogen (inertia principle). The objective is to prevent penetration of atmospheric humidity and the resulting corrosion on the internal walls and on non-protected steel surfaces.

3. Repair safety considerations

Note: It is compulsory to wear personal protection equipment. The insulation must be removed and warming up must be limited by using a wet cloth. Before opening the unit always ensure that the circuit has been purged.

- All installation parts must be maintained by qualified and skilled technicians, in order to avoid material deterioration and injuries to people. Faults and leaks must be repaired immediately. The authorized technician must have the responsibility to repair the fault immediately. Each time repairs have been carried out to the unit, the operation of the safety devices must be re-checked.
- Comply with the regulations and recommendations in unit and installation safety standards. If a leak occurs or if the refrigerant becomes contaminated (e.g. by a short circuit in a motor) remove the complete charge using a recovery unit and store the refrigerant in mobile containers.
- Repair the leak detected and recharge the circuit with the total R134a charge, as indicated on the unit name plate. Certain parts of the circuit can be isolated. Only charge liquid refrigerant R134a at the liquid line. Ensure that you are using the correct refrigerant type before recharging the unit. Charging any refrigerant other than the original charge type (R134a) will impair machine operation and can even lead to a destruction of the compressors. The compressors operating with this refrigerant type are lubricated with synthetic oil.
- Do not use oxygen to purge lines or to pressurize a machine for any purpose. Oxygen gas reacts violently with oil, grease, and other common substances.
- Never exceed the specified maximum operating pressures. Verify the allowable maximum high- and low-side test pressures by checking the instructions in this manual and the pressures given on the unit name plate.
- Do not use air for leak testing. Use only refrigerant or dry nitrogen.
- Do not weld or flame cut the refrigerant lines or any refrigerant circuit component until all refrigerant (liquid and vapor) has been removed from chiller. Traces of vapor should be displaced with dry air nitrogen. Refrigerant in contact with an open flame produces toxic gases.
- The necessary protection equipment must be available, and appropriate fire extinguishers for the system and the refrigerant type used must be within easy reach.
- Do not siphon refrigerant. Avoid spilling liquid refrigerant on skin or splashing it into the eyes. Use safety goggles. Wash any spills from the skin with soap and water. If liquid refrigerant enters the eyes, immediately and abundantly flush the eyes with water and consult a doctor.
- Never apply an open flame or live steam to a refrigerant container. Dangerous overpressure can result. If it is necessary to heat refrigerant, use only warm water.

- During refrigerant removal and storage operations follow applicable regulations. These regulations, permitting conditioning and recovery of halogenated hydrocarbons under optimum quality conditions for the products and optimum safety conditions for people, property and the environment.
- Any refrigerant transfer and recovery operations must be carried out using a transfer unit. The units must never be modified to add refrigerant and oil charging, removal and purging devices. All these devices are provided with the units. Please refer to the certified dimensional drawings for the units.
- Do not re-use disposable (non-returnable) cylinders or attempt to refill them. It is dangerous and illegal. When cylinders are empty, evacuate the remaining gas pressure, and move the cylinders to a place designated for their recovery. Do not incinerate.
- Do not attempt to remove refrigerant circuit components or fittings, while the machine is under pressure or while it is running. Be sure pressure is at 0 kPa before removing components or opening a circuit.
- Do not attempt to repair or recondition any safety devices when corrosion or build-up of foreign material (rust, dirt, scale, etc.) is found within the valve body or mechanism.
- If necessary, replace the device. Do not install safety valves in series or backwards.

ATTENTION:

No part of the unit must be used as a walkway, rack or support. Periodically check and repair or if necessary replace any component or piping that shows signs of damage. The refrigerant lines can break under the weight and release refrigerant, causing personal injury. Do not climb on a machine. Use a platform, or staging to work at higher levels.

- Use mechanical lifting equipment (crane, hoist, winch, etc.) to lift or move heavy components. For lighter components, use lifting equipment when there is a risk of slipping or losing your balance.
- Use only original replacement parts for any repair or component replacement.
- Do not drain water circuits containing industrial brines, without informing the technical service department at the installation site or a competent body first.
- Close the entering and leaving water shut off valves and purge the unit water circuit, before working on the components installed on the circuit (screen filter, pump, water flow switch, etc.).
- Do not close the water box bolts until the water boxes have been completely drained.
- Periodically inspect all valves, fittings and pipes of the refrigerant and hydronic circuits to ensure that they do not show any corrosion or any signs of leaks.
- It is recommended to wear ear defenders, when working near the unit and the unit is in operation.

II. Product

1. General Information

1) Product Line Up

Series	Model	Power Supply	Cooling Capacity (kW)	Quantity of Compressor
Single head	MWSC340A-FB3	380V/3Ph/50Hz	340	1
	MWSC440A-FB3	380V/3Ph/50Hz	440	1
	MWSC540A-FB3	380V/3Ph/50Hz	540	1
	MWSC690A-FB3	380V/3Ph/50Hz	690	1
Dual head	MWSC805A-FB3	380V/3Ph/50Hz	805	1
	MWSC890A-FB3	380V/3Ph/50Hz	890	1
	MWSC1080A-FB3	380V/3Ph/50Hz	1080	2
	MWSC1200A-FB3	380V/3Ph/50Hz	1200	2
	MWSC1385A-FB3	380V/3Ph/50Hz	1385	2
	MWSC1620A-FB3	380V/3Ph/50Hz	1620	2
	MWSC1780A-FB3	380V/3Ph/50Hz	1780	2

3). External appearance

Single head(MWSC340A-FB3~ MWSC890A-FB3)



Dual head(MWSC1080A-FB3~ MWSC1780A-FB3)



2. Features

+ High efficiency

- High efficiency inner grooved copper pipe enhances the heat-exchange process, improves heat exchange efficiency and makes the evaporator more compact to save installation space.
- Significantly improve the evaporating temperature and reduce heat transferring temperature difference which directly improves heat-exchange efficiency, provide most cost effective & reliable solutions to all valuable customers.
- Supreme efficiency in partial load.

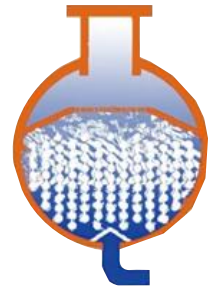

+ Green chiller

- R134a environmental-friendly refrigerant
Refrigerant of the Chlorine-free HFC with zero ODP (Ozone Depletion Potential).
Very low GWP (Global Warming Potential).



+ High reliability and excellent serviceability

Advanced twin-rotor screw compressor

Capacity adjustable valve

Four stage capacity adjustable or stepless adjustable.

Refrigerant discharge

Exhaust cavity with check valve, it can avoid compressor to reversal cause of stopping for long time.

Built-in oil separator

High precision filter, the oil separation efficiency up to 99.5%.

Motor direct drive

High mechanical efficiency, low speed of compressor, low noise.

Twin screw rotor

Patent type line design, high volumetric efficiency, smooth operation.

Hermetic motor

Cool motor with refrigerant, no heat send out in room.

Semi-hermetic structure

Semi-hermetic compressor, moveable bolts, easy to maintain.

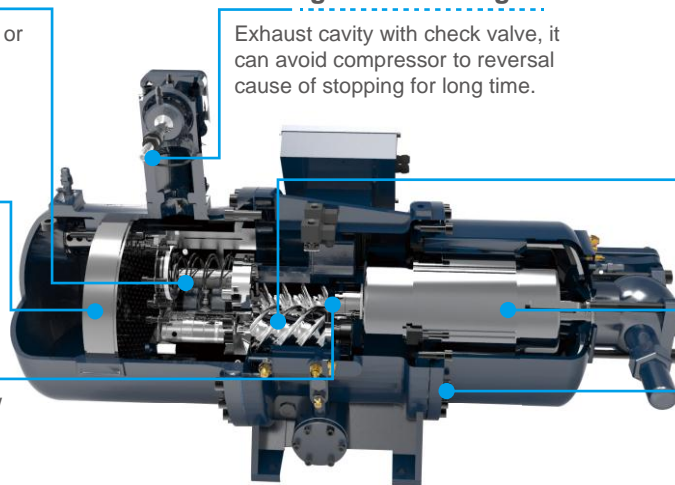

+ High efficiency heat exchange technology

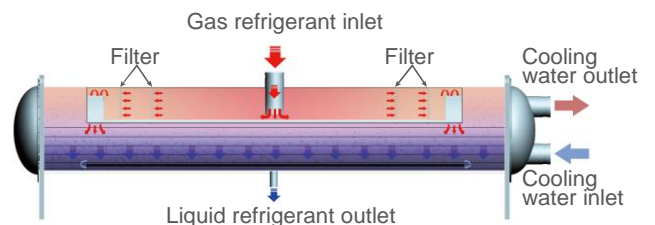
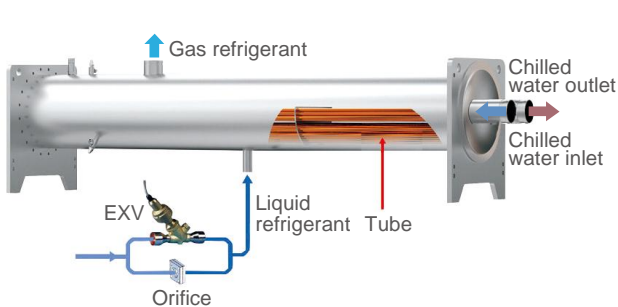

High efficiency shell and tube heat exchanger, 2 path, straight water pipe, easy to clean. End cover can be exchanged to meet customer's requirement for condenser.

- Flooded evaporator makes cleaning inside of pipes possible, and guarantees high reliability.
- Discharge cut-off valve and liquid line angle valve for simplified maintenance.
- Simplified field wiring for easy installation.

✚ **Optimized & user-friendly operating Interface**

- Midea chiller adopts Midea Microprocessor which provides advanced algorithm and reliable control.
- Graphical display of the operating state, operation scheduling, malfunction inquiry, help menu for easy trouble shooting and other user-oriented functions.

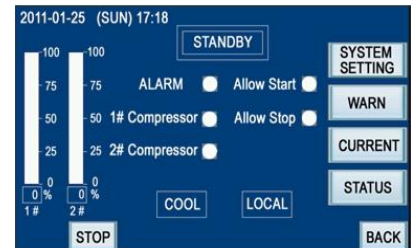

✚ **Compressor bearing**

High-precision large-sized axial and radial bearings are selected to support the male and female rotors for long lasting life. With effective lubrication system, the bearing service life can be further extended. While the compressor is running, lubricant is injected into all bearings due to pressure difference.



SKF brand industry use bearing guarantees 60,000h continuous working

✚ **Advanced twin-rotor screw compressor**

Midea® Screw Chiller equipped with the 3rd generation industrial Semi-hermetic Screw compressor that has the latest advanced 5-6 asymmetry dentiform rotors. The rotors are processed by high-precision CNC and each part is well-proportioned and none-gap matching, which minimize the friction resistance and clearance loss, guarantee quiet running and good duration.

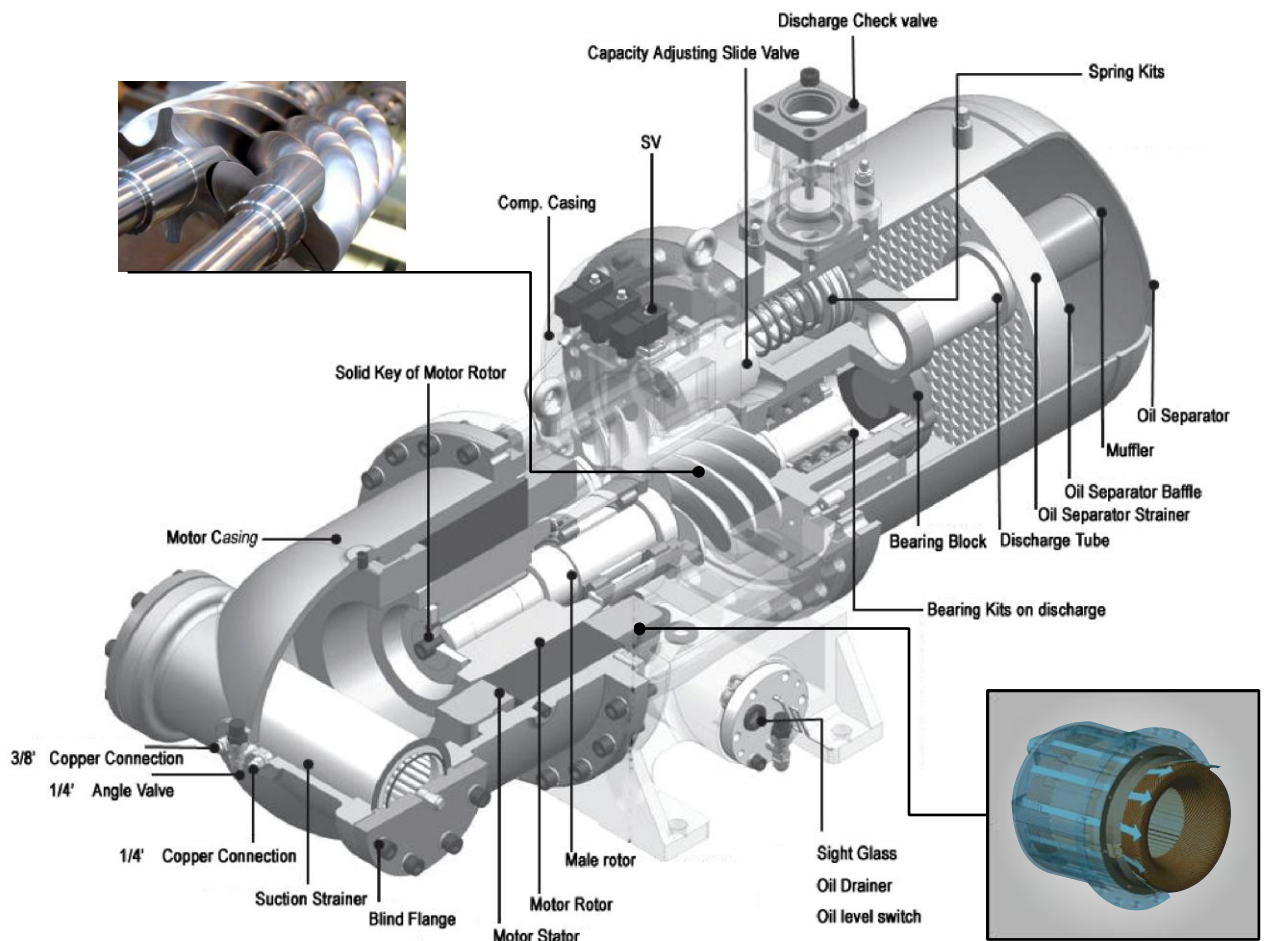

- High-precision machining and measurement make rotor clearance reach μm -class, so it reduces the leakage between high and low pressure. Under continuous operation, the rotors still keep their best clearance and achieve highest efficiency.
- Semi-hermetic compressor with low running noise and well cooled down by refrigerant, low running temperature, no leakage potential compared with open compressor.
- Patented motor-cooling design in ducts of refrigerant flow encompassing stator provides best dissipation of heat and no requirement for computer room AC.
- To reach high operation efficiency, the casing is manufactured by precise machining centers and inspected by a coordinate measuring machine to make sure that the requested precision and quality can be retained in the compressor.

✚ Three stages oil separation

- The built-in oil separator utilizes three-stage filter mechanism with high-density filter element to achieve optimal oil separation effect and its efficiency is higher than 99.7%. Two oil separators cooperate together make the best oil separating effect.
- Detachable demister for cleaning.
- Oil supplied by pressure difference and no need of oil pump.

✚ Dual compressors (Min. 1080 ~ Max.1780kW)

- Large cooling capacity chillers have two truly independent refrigerant circuits, compact outline and superior partial load efficiency. Besides, when one of the compressors breaks down, the other one can work independently. So the chiller can provide much higher reliability and minimize the loss of user.

Flooded-type evaporator

- Evaporator is flooded type designed for 1MPa working pressure on the chilled water side (Higher pressure vessels can be customized). Replaceable integral finned copper tubes are mechanically bonded to steel tube sheets. The evaporator has been tested under extreme conditions. The 20MM thickness insulation covers all low temperature surfaces, including the evaporator, water boxes, oil return lines, chilled water flow switch piping, etc.

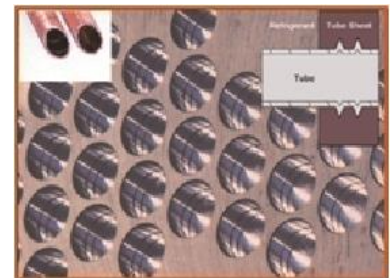

- Midea heat exchangers are designed by professional design software and pass rigorous tests. Double-grooved holes at tube support for tube expansion are designed to prevent leakage and increase the durability of heat exchanger.

Condenser

- Midea condenser has a specially designed baffle, in the entrance of condenser, to prevent direct impingement of high-velocity refrigerant gas on tube surface and thus eliminate the related vibration and noise. It has been tested under extreme conditions. Water side working pressure is designed for 1.0Mpa (Higher pressure vessels can be customized).

Throttling device

Orifice baffle without moving parts can guarantee high reliability and it cooperates with EXV (Danfoss) to throttle the high-pressure liquid refrigerant from condenser to evaporator. EXV which is controlled by EVD module provides high-precision adjustment and perfectly

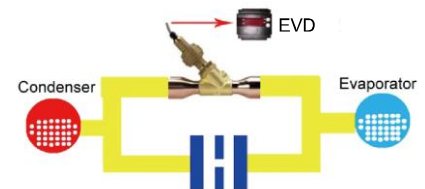

matches the compressor load , both full load and partial load.

Advanced oil system

As the diagram shown, the low temperature and low pressure gas enters the compressor through suction port. Then refrigerant gas that entered the compressor is compressed to a high temperature and high pressure gas and enters the condenser to release heat to cooling water. The condensed liquid passes the throttling device, becomes the

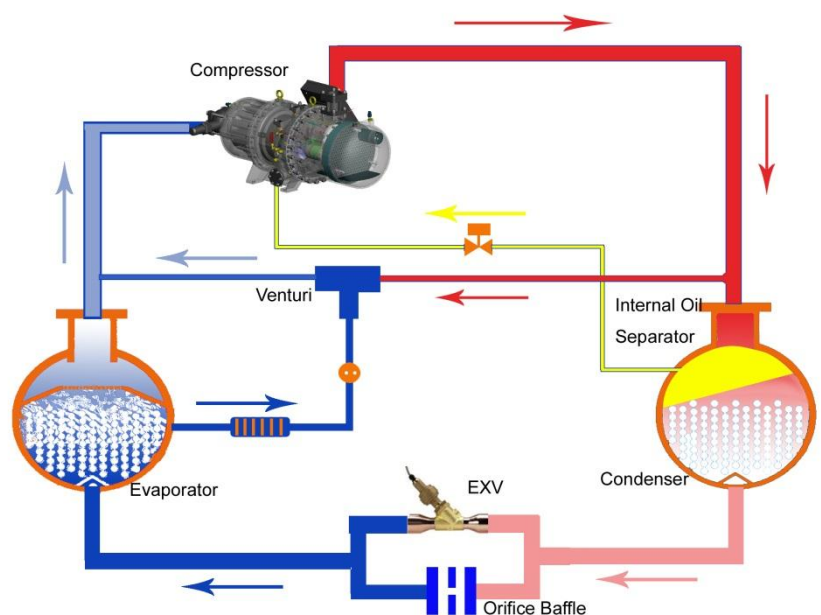

mixed state and enters the lower part of the evaporator. It is then spread into a wider surface by distributor. Finally the distributed refrigerant evaporates by taking the heat from the chilled water inside the evaporator tube and repeats the cycle.

Lubrication cycle

Three stages oil separation ensure the excellent compressor lubricant. One is integrated inside the compressor and the other is built-in oil separator located inside of the condenser. The refrigerant and oil mixture gets separated in the internal oil separator for the first time and then to the condenser oil separator of which the separating efficiency can reach 99%. Oil will return to compressor through the oil return pipe by pressure difference. Small amount of oil which remains in the evaporator will be sucked up by the Venturi tube and goes back to compressor after gas evaporating. This is the third stages oil separation. These three oil return circuits can guarantee reliable oil return efficiency.

3. Specifications

Single head

MWSC_A-FB3		340	440	540	690	805	890
Cooling capacity	kW	340	440	540	690	805	890
Power input	kW	60	77	94	120	140	155
EER	kW/kW	5.66	5.71	5.74	5.75	5.75	5.74
Semi-hermetic screw compressor							
Circuit A	Quantity	1	1	1	1	1	1
Circuit B	Quantity	--	--	--	--	--	--
Oil recharge							
Circuit A	L	18	20	23	28	40	40
Circuit B	L	--	--	--	--	--	--
Refrigerant	Type	R134a					
Circuit A	kg	130	145	160	200	230	250
Circuit B	kg	--	--	--	--	--	--
Control Type		EXV+Orifice					
Evaporator	Type	Shell and tube flooded					
Water content	L	150	170	190	210	240	270
Water flow	m ³ /h	58	76	93	119	138	153
Pressure drop	kPa	55	49	53	46	39	39
Max. pressure	kPa	1000	1000	1000	1000	1000	1000
Connection type		Victaulic coupling					
Water inlet/outlet pipe dim.	mm	150	150	150	200	200	200
Condenser	Type	Shell and tube					
Water content	L	150	170	190	210	240	270
Water flow	m ³ /h	73	95	116	148	173	191
Pressure drop	kPa	75	70	77	66	56	56
Max. pressure	kPa	1000	1000	1000	1000	1000	1000
Connection type		Victaulic coupling					
Water inlet/outlet pipe dim.	mm	150	150	150	200	200	200
Unit length	mm	3550	3550	3550	3600	3600	3600
Unit width	mm	1220	1220	1220	1420	1440	1440
Unit height	mm	1730	1800	1900	2000	2020	2020
Shipping weight	kg	2500	2580	2950	3550	4050	4150
Running weight	kg	2700	2820	3220	3870	4420	4550
Safety protection device		<p>The following safety devices are equipped as standard.</p> <ul style="list-style-type: none"> High pressure protection(High pressure switch & high pressure sensor) Low pressure protection(Low pressure switch & low pressure sensor) Compressor thermal protection High discharge temperature on the compressor Phase monitor; Star/Delta transition failed Low-pressure ratio; Low oil level protection Interrupter protection; Overload compressor protection Over-voltage & low- voltage protection Sensor malfunction protection Contactormalfunction protection Freeze protection 					

Note:

Nominal cooling capacities are based on following conditions: Chilled water inlet/outlet temperature 12/7 °C (53.6F/44.6F); Cooling water inlet/outlet temperature 30/35 °C (86F/96F).

The design fouling factor for both evaporator and condenser are 0.086m²·°C/kW (0.0005ft² F.hr/Btu).

Dual head

MWSC_A-FB3		1080	1200	1385	1620	1780
Cooling capacity	kW	1080	1200	1385	1620	1780
Power input	kW	186	206	238	278	306
EER	kW/kW	5.8	5.82	5.81	5.82	5.81
Semi-hermetic screw compressor						
Circuit A	Quantity	1	1	1	1	1
Circuit B	Quantity	1	1	1	1	1
Oil recharge						
Circuit A	L	23	28	28	40	40
Circuit B	L	23	28	28	40	40
Refrigerant	Type	R134a				
Circuit A	kg	170	180	190	210	220
Circuit B	kg	170	180	190	210	220
Control type		EXV+Orifice				
Evaporator	Type	Shell and tube flooded				
Water content	L	350	400	460	520	580
Water flow	m ³ /h	186	206	238	279	306
Pressure drop	kPa	78	79	79	75	76
Max. pressure	kPa	1000	1000	1000	1000	1000
Connection type		Victaulic coupling				
Water inlet/outlet pipe dim.	mm	200	200	200	200	200
Condenser	Type	Shell and tube				
Water content	L	350	400	460	520	560
Water flow	m ³ /h	232	258	298	348	383
Pressure drop	kPa	88	87	87	85	86
Max. pressure	kPa	1000	1000	1000	1000	1000
Connection type		Victaulic coupling				
Water inlet/outlet pipe dim.	mm	200	200	200	200	200
Unit length	mm	4600	4600	4600	4800	4800
Unit width	mm	1520	1520	1520	1620	1620
Unit height	mm	2035	2035	2035	2250	2250
Shipping weight	kg	6700	6900	7150	8350	8450
Running weight	kg	7250	7490	7820	9200	9350
Safety protection device	The following safety devices are equipped as standard. High pressure protection(High pressure switch & high pressure sensor) Low pressure protection(Low pressure switch & low pressure sensor) Compressor thermal protection High discharge temperature on the compressor Phase monitor; Star/Delta transition failed Low-pressure ratio; Low oil level protection Interrupter protection; Overload compressor protection Over-voltage & low- voltage protection Sensor malfunction protection Contactor malfunction protection Freeze protection					

Note:

Nominal cooling capacities are based on following conditions: Chilled water inlet/outlet temperature 12/7 °C (53.6F/44.6F); Cooling water inlet/outlet temperature 30/35 °C (86F/96F).

The design fouling factor for both evaporator and condenser are 0.086m²·°C/kW (0.0005ft² F.hr/Btu).

4. Outline dimension

Single head (MWSC340~890A-FB3)

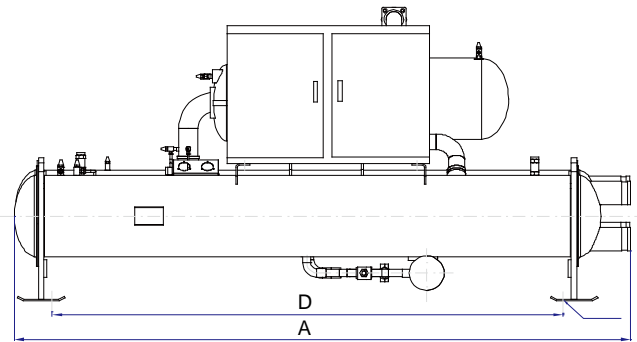
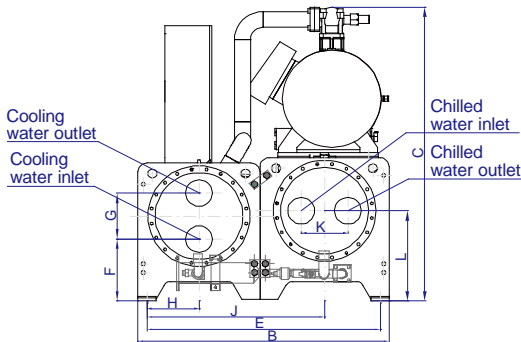

Unit: mm

Model	A	B	C	D	E	F	G	H	J	K	L	Water inlet/outlet Dim.
MWSC340A-FB3	3550	1220	1730	2850	1100	411	260	250	850	260	541	DN150
MWSC440A-FB3	3550	1220	1800	2850	1100	411	260	250	850	260	541	DN150
MWSC540A-FB3	3550	1220	1900	2850	1100	411	260	250	850	260	541	DN150
MWSC690A-FB3	3600	1420	2000	2850	1300	451	280	300	1000	280	591	DN200
MWSC805A-FB3	3600	1440	2020	2850	1300	451	280	300	1000	280	591	DN200
MWSC890A-FB3	3600	1440	2020	2850	1300	451	280	300	1000	280	591	DN200

Dual heads(MWSC1080~1780A-FB3)

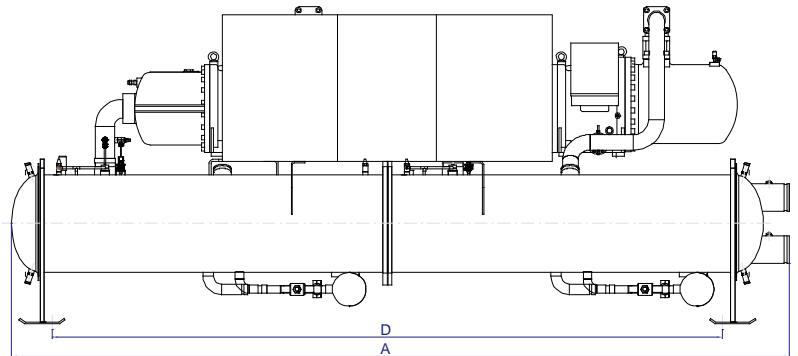
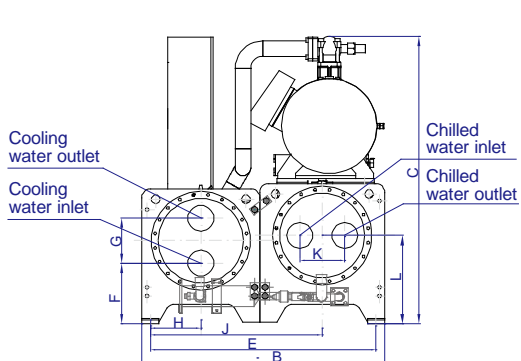

Unit: mm

Model	A	B	C	D	E	F	G	H	J	K	L	Water inlet/outlet Dim.
MWSC1080A-FB3	4600	1520	2035	3850	1400	443	350	325	1075	350	618	DN200
MWSC1200A-FB3	4600	1520	2035	3850	1400	443	350	325	1075	350	618	DN200
MWSC1385A-FB3	4600	1520	2035	3850	1400	443	350	325	1075	350	618	DN200
MWSC1620A-FB3	4800	1620	2250	3850	1500	468	350	350	1150	350	643	DN200
MWSC1780A-FB3	4800	1620	2250	3850	1500	468	350	350	1150	350	643	DN200

NOTE: Drawings are not contractually binding. Before designing an installation, consult the certified dimensional drawings supplied with the unit or available on request.

For the positioning of the fixing points, weight distribution and center of gravity coordinates please refer to the dimensional drawings.

5. Refrigeration system

For single head unit(MWSC340~890A-FB3)

Code	Name
	Pressure Gauge
	Temperature Sensor
	Sight glass
	Filter
	Solenoid Valve
	Safety Valve
	Check Valve
	Shut-off Valve
	Refrigerant Gas Line
	Refrigerant Liquid Line
	Oil way
	Water way
	Throttle plate
	High/Low Pressure Switch
	Electric expansion valve
	Venturi Tube
	Pressure Difference Switch

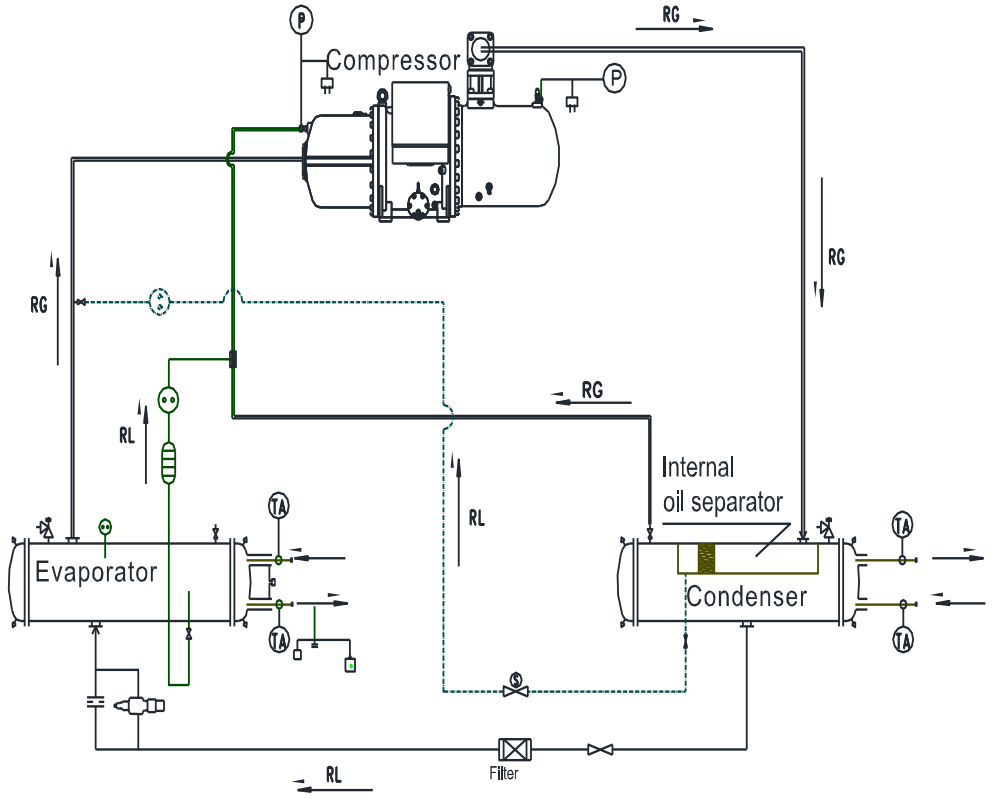

For dual heads unit (MWSC1080~1780A-FB3)

Code	Name
	Pressure Gauge
	Temperature Sensor
	Sight glass
	Filter
	Solenoid Valve
	Safety Valve
	Check Valve
	Shut-off Valve
	Refrigerant Gas Line
	Refrigerant Liquid Line
	Oil way
	Water way
	Throttle plate
	High/Low Pressure Switch
	Electric expansion valve
	Venturi Tube
	Pressure Difference Switch

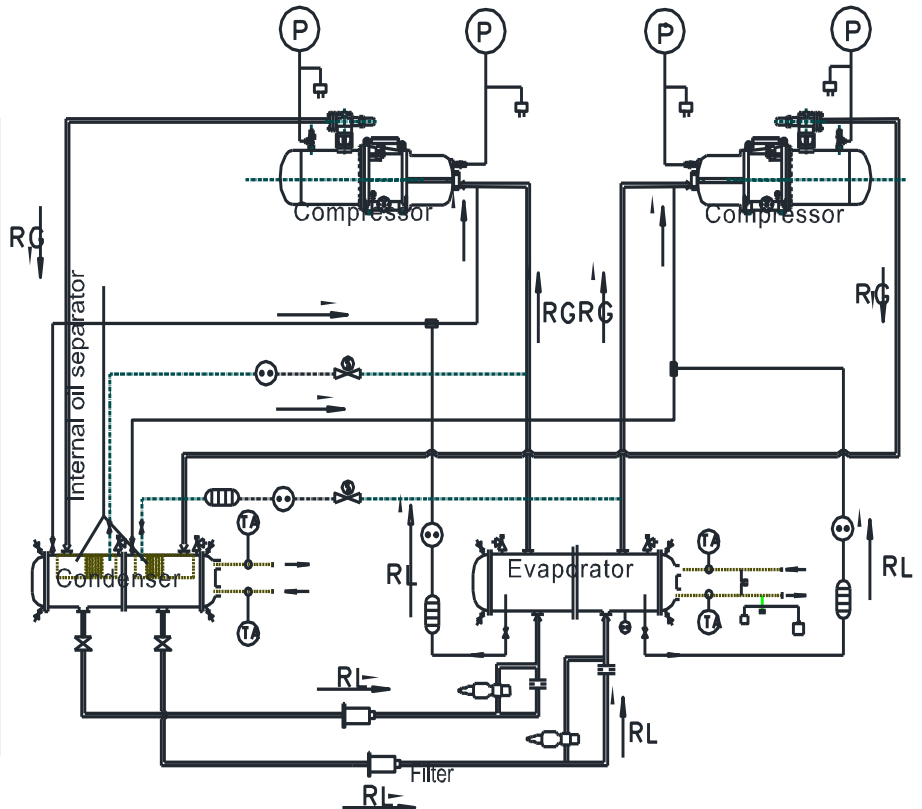

6. Major system components

6.1 Advanced twin screw compressor

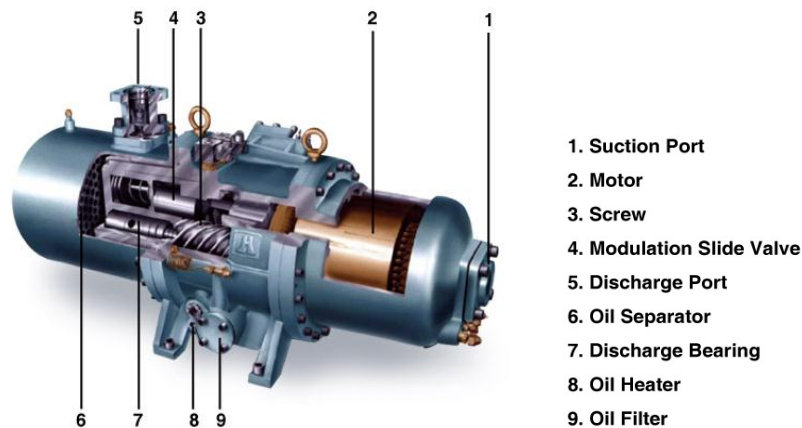

- Midea screw chiller equipped with the 3rd generation industrial compressor that has the latest advanced 5-6 Asymmetry Dentiform Semi-hermetic Screw Rotors. The rotors are processed by high-precision CNC and each part is well-proportioned and none-gap matching, which minimizes the friction resistance and clearance lost, guarantees quiet running and good duration.
- MWSC_A-FB3 Series units are provided with a high efficiency oil separator to maximize oil extraction.
- Compressors have a infinitely variable control down to 25% of its total capacity. This control is made by means of capacity slides controlled by microprocessors.
- Standard starter is star-delta type. Infinitely capacity control type is available (as option).
- With 5-6 asymmetry dentiform, the screw rotor gained patent by improving the shape of German rotor GHH, proved having good balance, small vibration, and low noise due to balance testing by special machine. Comparing with normal screw rotor with 4-6 dentiform, heat efficiency of the rotor with male and female rotor adopting 5-6 dentiform increase by 10-12% and energy saves by 25%, the rotor also gained British and American patent.

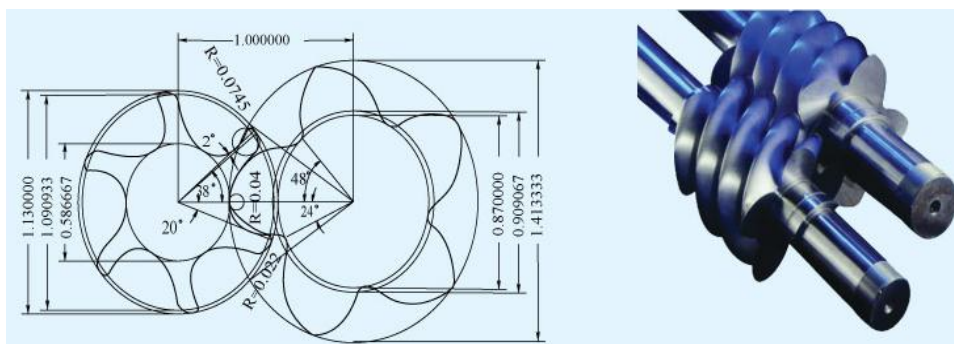

- The bearing of compressor is from SKF, Sweden, the long lifespan of which ensures screw-type main unit to run continuously more than 50,000 hours.



➤ Lubricant:

The lubricant is supplied automatically by pressure difference inside the compressor. It is unnecessary to add an extra lubricant pump.

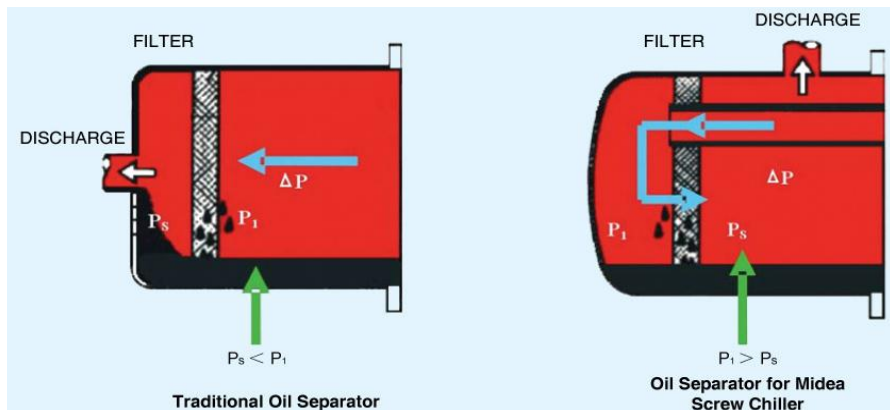

The compressor is approved for use with the following lubricant:

HBR-B04 for R134a unit

- The Oil Separator comes from MANN of Germany and has reliable qualification. The oil content can be controlled below 3ppm (the oil content treated by oil-gas separator of common like screw-type air compressor is no less than 8-10ppm). The oil-gas separator amount is double of same kind of other products. The large oil filtering area reduces refrigerant flux speed, and has better separating affect and long lifespan by the secondary reflux technology adopted.

➤ Oil filter

The screw compressor has an independent oil filter.

6.2 Pressure vessels

6.2.1 General

Monitoring during operation, re-qualification, re-testing and re-testing dispensation:

- Follow the regulations on monitoring pressurized equipment.
- It is normally required that the user or operator sets up and maintains a monitoring and maintenance file.
- Follow the control programs.
- If they exist follow local professional recommendations.
- Regularly inspect the condition of the coating (paint) to detect blistering resulting from corrosion. To do this, check a non-insulated section of the container or the rust formation at the insulation joints.
- Regularly check for possible presence of impurities (e.g. silicon grains) in the heat exchange fluids. These impurities maybe the cause of the wear or corrosion by puncture
- Filter the heat exchange fluid check and carry out internal inspections as described in EN 378-2, annex C.
- In case of re-testing please refer to the maximum operating pressure given on the unit nameplate.
- The reports of periodical checks by the user or operator must be included in the supervision and maintenance file.

6.2.2 Repair

Any repair or modification, including the replacement of moving parts:

- Must follow local regulations and be made by qualified operators and in accordance with qualified procedures, including changing the heat exchanger tubes.
- Must be made in accordance with the instructions of the original manufacturer. Repair and modification that necessitate permanent assembly (soldering, welding, expanding etc.) must be made using the correct procedures and by qualified operators.
- An indication of any modification or repair must be shown in the monitoring and maintenance file.

6.2.3 Corrosion allowances:

Gas side: 0 mm

Heat exchange fluid side: 1 mm for tubular plates in lightly alloyed steels, 0 mm for stainless steel plates or plates with copper-nickel or stainless steel protection.

6.2.4 Operating life

The evaporator and condenser are designed for: prolonged usage of 20 years for high-quality materials.

6.2.5 Security

The unit is equipped with safety valves. And ball valve is connecting safety valve to condenser (evaporator). The ball valve maintain full-state, it is closed only when safety valve is opening or replaced.

Ball valve can protect life and property because it can prevent refrigerant from flowing into the air when safety valve is opening or replaced.

6.2.6 Evaporator

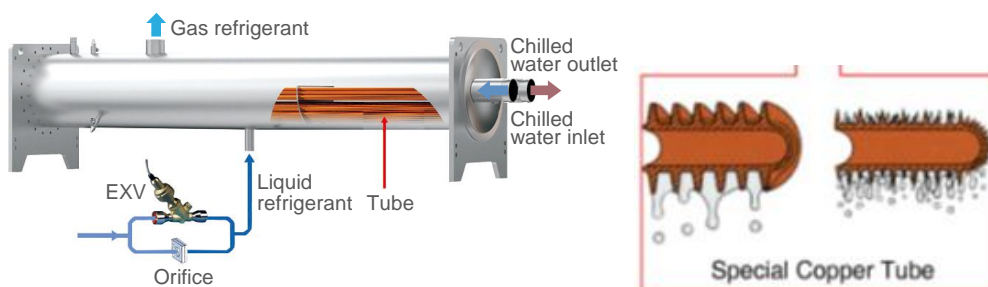

Flooded shell and tube evaporator operates with refrigerant in shell and water in tubes. Replaceable water tubes are fabricated from integral finned cooper and mechanically bonded to steel tube sheets. The evaporator is GB151-1999 (Chinese standard) designed, constructed, inspected and stamped. Water side working pressure is designed for 1.0Mpa. Shell and non-connection water head are insulated with 3/4" thick closed cell insulation.

6.2.7 Condenser

Shell and tube operates with refrigerant in shell and water in tubes. Replaceable water tubes are fabricated from integral finned cooper and mechanically bonded to steel tube sheets. The condenser is GB151-1999 (Chinese Standard) designed, constructed, inspected and stamped. Water side working pressure is designed for 1.0Mpa.

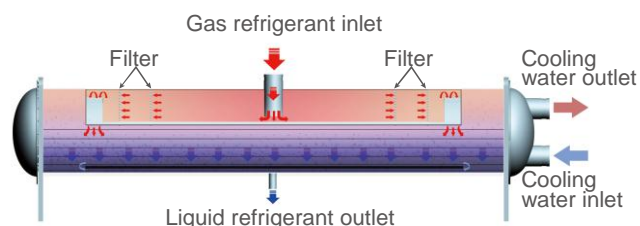

The condenser is used high-efficient tubes to enhance its transfer performance. Meanwhile, the system's COP can be increased largely by adding the subcooler.

6.2.8 Oil separator

The oil separator with unique structure separate oil from refrigerant high-efficiently. It is solve the oil recycle problem by ensure oil return to compressor normally.

6.2.9 Throttle parts

The unit achieves high-efficiency when full load and part load by parallel connecting orifice and EXV.

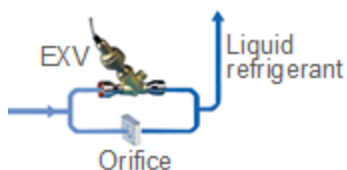

7. Water flow

Balance the chilled water flow through the evaporator and the condenser water flow through the condenser. The flow rates must fall between the minimum and maximum values shown in the below table. Flow rates below the minimum values shown will result in laminar flow which will reduce efficiency, cause erratic operation of the electronic expansion valve and could cause low temperature cutouts. On the other hand, flow rates exceeding the maximum values shown can cause erosion on the heat exchanges water connections and tubes, even piping breaking.

Variable chilled water flow through the heat exchanges while the compressor(s) are operating is not recommended. The chiller control set points are based upon a constant flow and variable temperature.

Model	Evaporator water flow rate m ³ /h			Condenser water flow rate m ³ /h		
	Rated	Minimum	Maximum	Rated	Minimum	Maximum
MWSC340A-FB3	58	29	64	73	37	80
MWSC440A-FB3	76	38	83	95	47	104
MWSC540A-FB3	93	46	102	116	58	128
MWSC690A-FB3	119	59	131	148	74	163
MWSC805A-FB3	138	69	152	173	87	190
MWSC890A-FB3	153	77	168	191	96	210
MWSC1080A-FB3	186	93	204	232	116	255
MWSC1200A-FB3	206	103	227	258	129	284
MWSC1385A-FB3	238	119	262	298	149	328
MWSC1650A-FB3	279	142	312	348	177	390
MWSC1780A-FB3	306	153	337	383	191	421

Pressure drop

Flooded type (Evaporator)

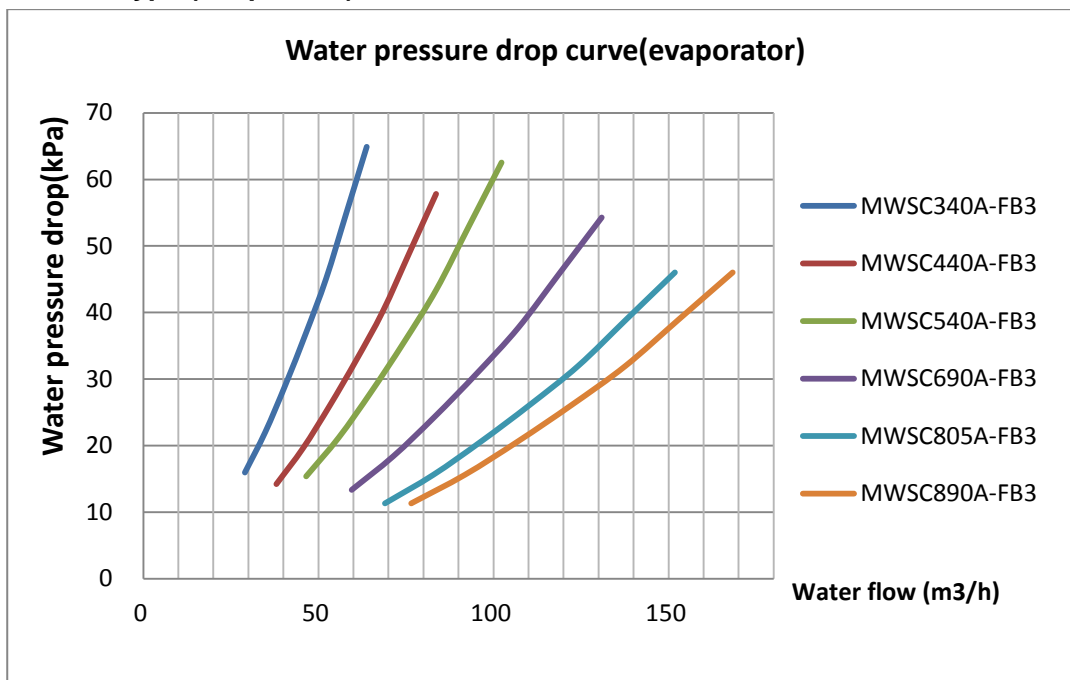

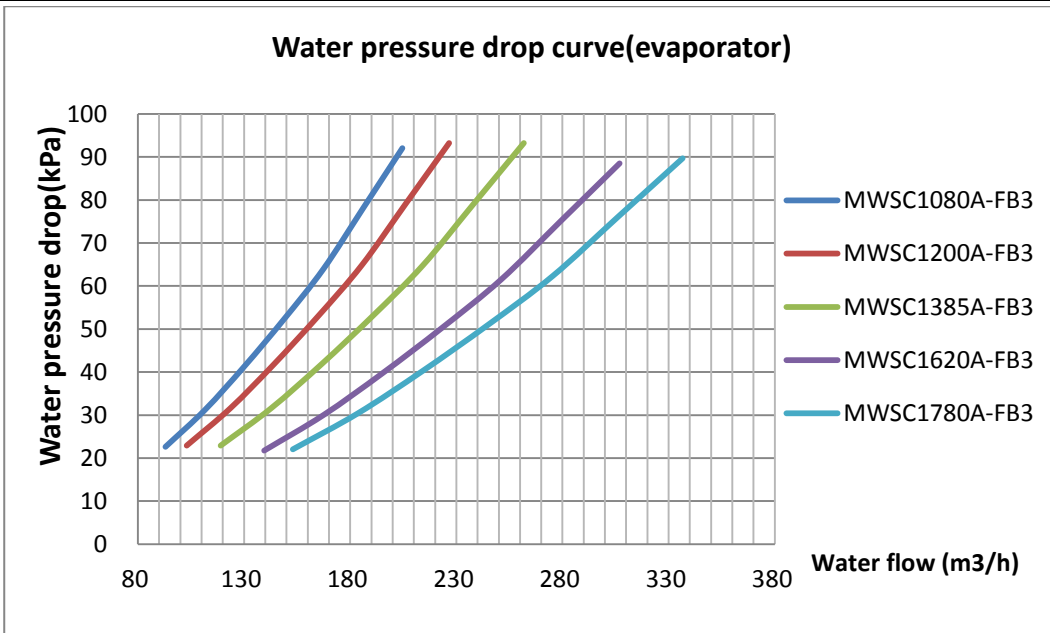

Flooded type (Condenser)

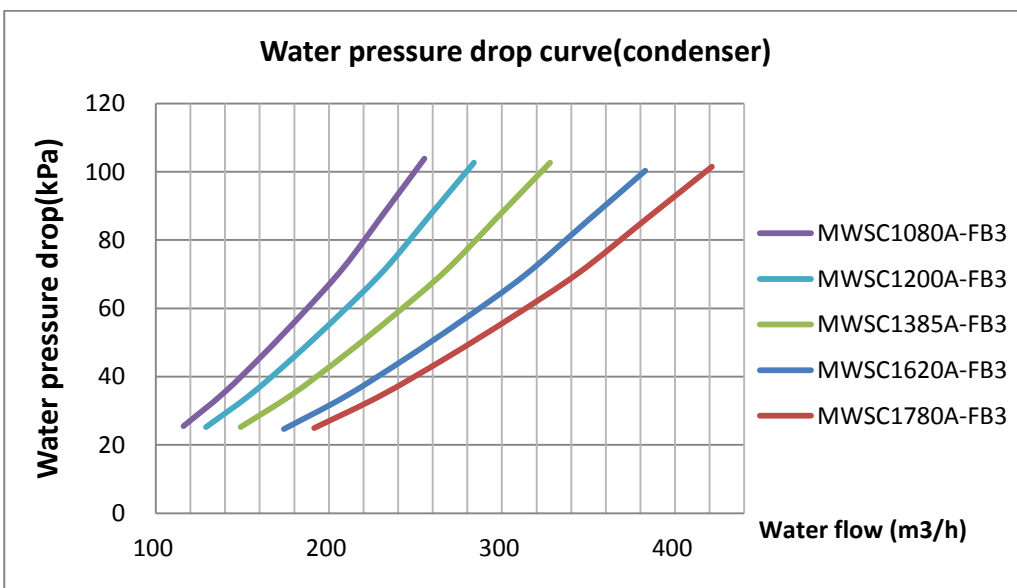
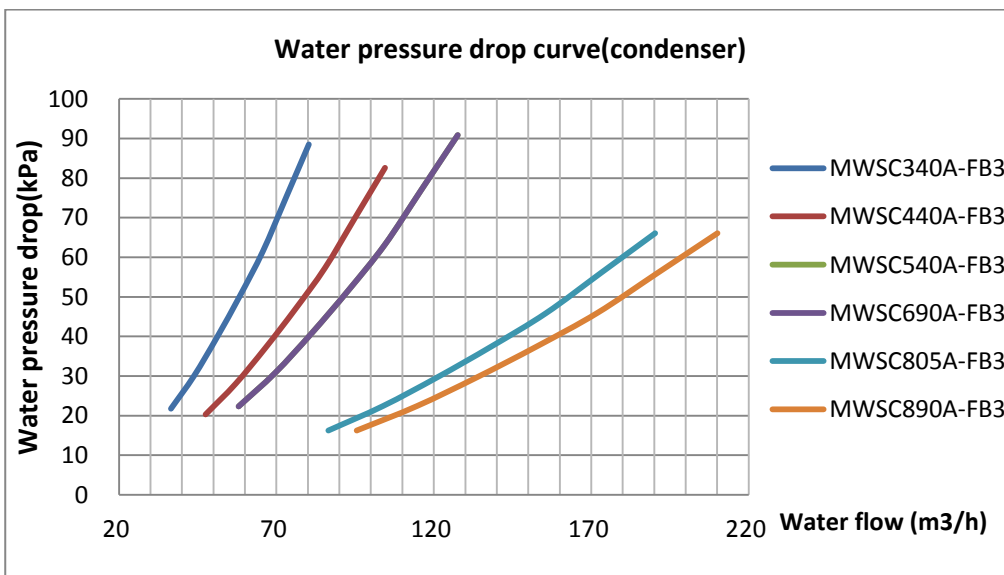

System minimum water volume

Water volume is necessary for stable operation. It is often necessary to add a buffer water tank to the circuit in order to achieve the required volume. The tank must itself be internally baffled in order to ensure proper mixing of the liquid (water or brine). Water tank volume is large than 1 / 10 whole system water volume at least.

Refer to the examples below.

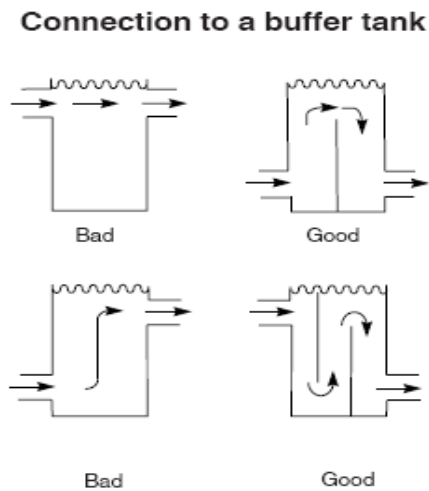

How to calculate minimum volume in pipeline system:

$$W = Q_g T / CP \Delta t$$

W — Minimum water volume (kg) ;

Q_g — Total cooling/heating capacity of the terminal (kW) ;

T — Thermal stability time requirement, Take (8~10) ×60s;

CP — Water specific heat at constant pressure, 4.187kj/ (kg·°C) ;

Δt — Water temperature fluctuation required value, take 5°C.

For system, Q_g is calculated according to the lowest load so that it operates steadily.

It can also calculated according to 0.5Q(50%). T takes 8 minutes, the shortest time that the unit running.

That is 480s. Cp=4.18kj/kg, Δt =5°C

According to the above formula, the result is as following:

$$W = 0.5Q * 480 / (4.18 * 5) = 11.48Q \text{ kg}$$

Note:

The above formula is only for reference, different factor should be adopted to suit for different condition.

8. Operating range

Content	Running range
Chilled Leaving Water Temperature	5°C ~ 15°C
Cooling Entering water Temperature	20°C ~ 35°C
Water flow volume	Rating flow volume ± 20%
Max inlet/outlet water Temp. difference	8°C
Fouling factor (m ² ·°C/kW)	0.086
Voltage tolerance	Rating Voltage ± 10%
Phase tolerance	± 2%
Power supply frequency	Rating frequency ± 2%
Evaporator max working pressure on water side	1.0MPa
Compressor max. start count	4 times/h
Environment quality	High corrosive environment and high humidity should be avoided.
Drainage system	The height of water drainage should not be higher than the base of the unit on the spot
Normal operation ambient temperature	-10°C ~ 45°C
Storage and transport temperature	-15°C ~ 50°C
Applicable altitude range:	No more than 1000m

MWSC_A-FB3 evaporator	Minimum	Maximum
Entering temperature at start-up	9°C	22°C
Leaving temperature during operation	5°C	15°C
Entering/leaving temperature difference at full load	3.8°C	7.1°C

MWSC_A-FB3 condenser	Minimum	Maximum
Entering temperature at start-up	19°C	33°C
Leaving temperature during operation	23°C	40°C
Entering/leaving temperature difference at full load	3.8°C	7.1°C

Note:

- (1) For low-temperature applications, where the leaving water temperature is below 4°C, freeze protection switch will work unit stop.
- (2) If the temperature leaving the condenser is below 19°C, the unit will stop and warning
- (3) Ambient temperatures: During storage and transport of the MWSC_A-FB3 units. Including by container) the minimum and maximum permissible temperatures is -20°C ~ 46°C(R134a);

Changes water temperature curve in the operation

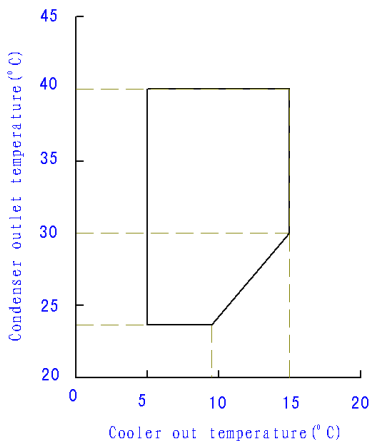

9. Capacity table

MWSC340A-FB3

Chilled Water Outlet Temp. (°C)	Cooling Water Inlet(°C)															
	25.00		26.00		27.00		29.00		30.00		32.00		33.00		35.00	
	Capacity kW	Power kW	Capacity kW	Power kW	Capacity kW	Power kW	Capacity kW	Power kW	Capacity kW	Power kW	Capacity kW	Power kW	Capacity kW	Power kW	Capacity kW	Power kW
5.00	334.56	54.19	331.61	56.34	328.67	56.94	322.49	58.26	319.26	58.98	313.48	60.66	309.74	61.62	302.26	63.54
6.00	346.46	55.98	343.06	56.78	339.66	57.40	332.86	58.77	329.46	59.52	323.68	61.14	319.83	62.12	312.12	64.08
7.00	356.32	55.74	353.15	57.26	349.97	57.88	343.40	59.25	340.00	60.00	332.86	61.68	329.23	62.70	321.98	64.74
8.00	368.22	56.16	364.82	57.68	361.42	58.30	354.45	59.70	350.88	60.48	343.74	62.22	338.53	63.30	328.10	65.46
9.00	378.76	56.64	375.59	58.10	372.41	58.72	365.67	60.18	362.10	61.02	354.62	62.76	350.54	63.82	342.38	65.94
10.00	389.30	57.06	386.58	58.60	383.86	59.24	376.72	60.69	372.30	61.50	365.50	63.36	361.65	64.38	353.94	66.42
11.00	/	/	397.46	59.08	394.74	59.72	387.94	61.23	384.20	62.04	377.06	63.84	372.98	64.90	364.82	67.02
12.00	/	/	/	/	405.62	60.20	399.84	61.68	395.42	62.52	388.96	64.44	384.77	65.50	376.38	67.62
13.00	/	/	/	/	/	/	411.74	62.22	407.32	63.12	400.52	64.98	396.44	66.06	388.28	68.22
14.00	/	/	/	/	/	/	425.00	62.58	421.60	63.30	412.42	65.52	408.34	66.62	400.18	68.82
15.00	/	/	/	/	/	/	437.75	63.06	434.86	63.78	425.34	66.06	421.15	67.18	412.76	69.42

Note: The above parameters are in accordance with the 7 °C evaporator water outlet, 30 °C condenser water inlet.

MWSC440A-FB3

Chilled Water Outlet Temp. (°C)	Cooling Water Inlet(°C)															
	25.00		26.00		27.00		29.00		30.00		32.00		33.00		35.00	
	Capacity kW	Power kW	Capacity kW	Power kW	Capacity kW	Power kW	Capacity kW	Power kW	Capacity kW	Power kW	Capacity kW	Power kW	Capacity kW	Power kW	Capacity kW	Power kW
5.00	432.96	71.53	429.15	72.30	425.33	73.07	417.34	74.77	413.16	75.69	405.68	77.85	400.84	79.08	391.16	81.54
6.00	448.36	72.07	443.96	72.87	439.56	73.66	430.76	75.42	426.36	76.38	418.88	78.46	413.89	79.72	403.92	82.24
7.00	461.12	72.69	457.01	73.48	452.91	74.28	444.40	76.04	440.00	77.00	430.76	79.16	426.07	80.47	416.68	83.08
8.00	476.52	73.23	472.12	74.02	467.72	74.82	458.70	76.62	454.08	77.62	444.84	79.85	438.09	81.24	424.60	84.01
9.00	490.16	73.77	486.05	74.56	481.95	75.36	473.22	77.23	468.60	78.31	458.92	80.54	453.64	81.90	443.08	84.62
10.00	503.80	74.38	500.28	75.20	496.76	76.02	487.52	77.89	481.80	78.93	473.00	81.31	468.01	82.62	458.04	85.24
11.00	/	/	514.36	75.82	510.84	76.64	502.04	78.58	497.20	79.62	487.96	81.93	482.68	83.29	472.12	86.01
12.00	/	/	/	/	524.92	77.26	517.44	79.16	511.72	80.23	503.36	82.70	497.93	84.06	487.08	86.78
13.00	/	/	/	/	/	/	532.84	79.85	527.12	81.00	518.32	83.39	513.04	84.78	502.48	87.55
14.00	/	/	/	/	/	/	550.00	80.31	545.60	81.24	533.72	84.08	528.44	85.50	517.88	88.32
15.00	/	/	/	/	/	/	566.50	80.93	562.76	81.85	550.44	84.78	545.01	86.21	534.16	89.09

Note: The above parameters are in accordance with the 7 °C evaporator water outlet, 30 °C condenser water inlet.

Flooded type water cooled screw chiller (PCB Control)

MWSC540A-FB3

Chilled Water Outlet Temp. (°C)	Cooling Water Inlet(°C)															
	25.00		26.00		27.00		29.00		30.00		32.00		33.00		35.00	
	Capacity	Power	Capacity	Power	Capacity	Power	Capacity	Power	Capacity	Power	Capacity	Power	Capacity	Power	Capacity	Power
	kW	kW	kW	kW	kW	kW	kW	kW	kW	kW	kW	kW	kW	kW	kW	kW
5.00	531.36	87.33	526.68	88.27	522.00	89.21	512.19	91.27	507.06	92.40	497.88	95.03	491.94	96.54	480.06	99.55
6.00	550.26	87.98	544.86	88.96	539.46	89.93	528.66	92.07	523.26	93.25	514.08	95.79	507.96	97.32	495.72	100.39
7.00	565.92	88.74	560.88	89.71	555.84	90.68	545.40	92.83	540.00	94.00	528.66	96.63	522.90	98.23	511.38	101.43
8.00	584.82	89.39	579.42	90.37	574.02	91.34	562.95	93.53	557.28	94.75	545.94	97.48	537.66	99.17	521.10	102.55
9.00	601.56	90.05	596.52	91.02	591.48	91.99	580.77	94.28	575.10	95.60	563.22	98.32	556.74	99.98	543.78	103.31
10.00	618.30	90.80	613.98	91.81	609.66	92.81	598.32	95.08	591.30	96.35	580.50	99.26	574.38	100.86	562.14	104.06
11.00	/	/	631.26	92.56	626.94	93.56	616.14	95.93	610.20	97.20	598.86	100.02	592.38	101.68	579.42	105.00
12.00	/	/	/	/	644.22	94.31	635.04	96.63	628.02	97.95	617.76	100.96	611.10	102.62	597.78	105.94
13.00	/	/	/	/	/	/	653.94	97.48	646.92	98.89	636.12	101.80	629.64	103.49	616.68	106.88
14.00	/	/	/	/	/	/	675.00	98.04	669.60	99.17	655.02	102.65	648.54	104.37	635.58	107.82
15.00	/	/	/	/	/	/	695.25	98.79	690.66	99.92	675.54	103.49	668.88	105.25	655.56	108.76

Note: The above parameters are in accordance with the 7 °C evaporator water outlet, 30 °C condenser water inlet.

MWSC690A-FB3

Chilled Water Outlet Temp. (°C)	Cooling Water Inlet(°C)															
	25.00		26.00		27.00		29.00		30.00		32.00		33.00		35.00	
	Capacity	Power	Capacity	Power	Capacity	Power	Capacity	Power	Capacity	Power	Capacity	Power	Capacity	Power	Capacity	Power
	kW	kW	kW	kW	kW	kW	kW	kW	kW	kW	kW	kW	kW	kW	kW	kW
5.00	678.96	111.48	672.98	112.68	667.00	113.88	654.47	116.52	647.91	117.96	636.18	121.32	628.59	123.24	613.41	127.08
6.00	703.11	112.32	696.21	113.56	689.31	114.80	675.51	117.54	668.61	119.04	656.88	122.28	649.06	124.24	633.42	128.16
7.00	723.12	113.28	716.68	114.52	710.24	115.76	696.90	118.50	690.00	120.00	675.51	123.36	668.15	125.40	653.43	129.48
8.00	747.27	114.12	740.37	115.36	733.47	116.60	719.33	119.40	712.08	120.96	697.59	124.44	687.01	126.60	665.85	130.92
9.00	768.66	114.96	762.22	116.20	755.78	117.44	742.10	120.36	734.85	122.04	719.67	125.52	711.39	127.64	694.83	131.88
10.00	790.05	115.92	784.53	117.20	779.01	118.48	764.52	121.38	755.55	123.00	741.75	126.72	733.93	128.76	718.29	132.84
11.00	/	/	806.61	118.16	801.09	119.44	787.29	122.46	779.70	124.08	765.21	127.68	756.93	129.80	740.37	134.04
12.00	/	/	/	/	823.17	120.40	811.44	123.36	802.47	125.04	789.36	128.88	780.85	131.00	763.83	135.24
13.00	/	/	/	/	/	/	835.59	124.44	826.62	126.24	812.82	129.96	804.54	132.12	787.98	136.44
14.00	/	/	/	/	/	/	862.50	125.16	855.60	126.60	836.97	131.04	828.69	133.24	812.13	137.64
15.00	/	/	/	/	/	/	888.38	126.12	882.51	127.56	863.19	132.12	854.68	134.36	837.66	138.84

Note: The above parameters are in accordance with the 7°C evaporator water outlet, 30 °C condenser water inlet.

Flooded type water cooled screw chiller (PCB Control)

MWSC805A-FB3

Chilled Water Outlet Temp. (°C)	Cooling Water Inlet(°C)															
	25.00		26.00		27.00		29.00		30.00		32.00		33.00		35.00	
	Capacity kW	Power kW	Capacity kW	Power kW	Capacity kW	Power kW	Capacity kW	Power kW	Capacity kW	Power kW	Capacity kW	Power kW	Capacity kW	Power kW	Capacity kW	Power kW
5.00	792.12	130.06	672.98	131.46	778.17	132.86	763.54	135.94	755.90	137.62	742.21	141.54	733.36	143.78	715.65	148.26
6.00	820.30	131.04	696.21	132.49	804.20	133.93	788.10	137.13	780.05	138.88	766.36	142.66	757.24	144.95	738.99	149.52
7.00	843.64	132.16	716.68	133.61	828.61	135.05	813.05	138.25	805.00	140.00	788.10	143.92	779.51	146.30	762.34	151.06
8.00	871.82	133.14	740.37	134.59	855.72	136.03	839.21	139.30	830.76	141.12	813.86	145.18	801.51	147.70	776.83	152.74
9.00	896.77	134.12	762.22	135.57	881.74	137.01	865.78	140.42	857.33	142.38	839.62	146.44	829.96	148.91	810.64	153.86
10.00	921.73	135.24	784.53	136.73	908.85	138.23	891.94	141.61	881.48	143.50	865.38	147.84	856.25	150.22	838.01	154.98
11.00	/	/	806.61	137.85	934.61	139.35	918.51	142.87	909.65	144.76	892.75	148.96	883.09	151.43	863.77	156.38
12.00	/	/	/	/	960.37	140.47	946.68	143.92	936.22	145.88	920.92	150.36	910.99	152.83	891.14	157.78
13.00	/	/	/	/	/	/	974.86	145.18	964.39	147.28	948.29	151.62	938.63	154.14	919.31	159.18
14.00	/	/	/	/	/	/	1006.25	146.02	998.20	147.70	976.47	152.88	966.81	155.45	947.49	160.58
15.00	/	/	/	/	/	/	1036.44	147.14	1029.60	148.82	1007.06	154.14	997.13	156.75	977.27	161.98

Note: The above parameters are in accordance with the 7 °C evaporator water outlet, 30 °C condenser water inlet.

MWSC890A-FB3

Chilled Water Outlet Temp. (°C)	Cooling Water Inlet(°C)															
	25.00		26.00		27.00		29.00		30.00		32.00		33.00		35.00	
	Capacity kW	Power kW	Capacity kW	Power kW	Capacity kW	Power kW	Capacity kW	Power kW	Capacity kW	Power kW	Capacity kW	Power kW	Capacity kW	Power kW	Capacity kW	Power kW
5.00	875.76	144.00	868.05	145.55	860.33	147.10	844.17	150.51	835.71	152.37	820.58	156.71	810.79	159.19	791.21	164.15
6.00	906.91	145.08	898.01	146.68	889.11	148.28	871.31	151.82	862.41	153.76	847.28	157.95	837.19	160.48	817.02	165.54
7.00	932.72	146.32	924.41	147.92	916.11	149.52	898.90	153.06	890.00	155.00	871.31	159.34	861.82	161.98	842.83	167.25
8.00	963.87	147.41	954.97	149.01	946.07	150.61	927.83	154.23	918.48	156.24	899.79	160.74	886.14	163.53	858.85	169.11
9.00	991.46	148.49	983.15	150.09	974.85	151.69	957.20	155.47	947.85	157.64	928.27	162.13	917.59	164.87	896.23	170.35
10.00	1019.05	149.73	1011.93	151.38	1004.81	153.04	986.12	156.78	974.55	158.88	956.75	163.68	946.66	166.32	926.49	171.59
11.00	/	/	1040.41	152.62	1033.29	154.28	1015.49	158.18	1005.70	160.27	987.01	164.92	976.33	167.66	954.97	173.14
12.00	/	/	/	/	1061.77	155.52	1046.64	159.34	1035.07	161.51	1018.16	166.47	1007.18	169.21	985.23	174.69
13.00	/	/	/	/	/	/	1077.79	160.74	1066.22	163.06	1048.42	167.87	1037.74	170.66	1016.38	176.24
14.00	/	/	/	/	/	/	1112.50	161.67	1103.60	163.53	1079.57	169.26	1068.89	172.10	1047.53	177.79
15.00	/	/	/	/	/	/	1145.88	162.91	1138.31	164.77	1113.39	170.66	1102.41	173.55	1080.46	179.34

Note: The above parameters are in accordance with the 7 °C evaporator water outlet, 30 °C condenser water inlet.

Flooded type water cooled screw chiller (PCB Control)

MWSC1080A-FB3

Chilled Water Outlet Temp. (°C)	Cooling Water Inlet(°C)															
	25.00		26.00		27.00		29.00		30.00		32.00		33.00		35.00	
	Capacity	Power	Capacity	Power	Capacity	Power	Capacity	Power	Capacity	Power	Capacity	Power	Capacity	Power	Capacity	Power
	kW	kW	kW	kW	kW	kW	kW	kW	kW	kW	kW	kW	kW	kW	kW	kW
5.00	1062.72	172.79	1053.36	174.65	1044.00	176.51	1024.38	180.61	1014.12	182.84	995.76	188.05	983.88	191.02	960.12	196.97
6.00	1100.52	174.10	1089.72	176.02	1078.92	177.94	1057.32	182.19	1046.52	184.51	1028.16	189.53	1015.92	192.57	991.44	198.65
7.00	1131.84	175.58	1121.76	177.51	1111.68	179.43	1090.80	183.68	1080.00	186.00	1057.32	191.21	1045.80	194.37	1022.76	200.69
8.00	1169.64	176.89	1158.84	178.81	1148.04	180.73	1125.90	185.07	1114.56	187.49	1091.88	192.88	1075.32	196.23	1042.20	202.93
9.00	1203.12	178.19	1193.04	180.11	1182.96	182.03	1161.54	186.56	1150.20	189.16	1126.44	194.56	1113.48	197.84	1087.56	204.41
10.00	1236.60	179.68	1227.96	181.66	1219.32	183.64	1196.64	188.14	1182.60	190.65	1161.00	196.42	1148.76	199.58	1124.28	205.90
11.00	/	/	1262.52	183.15	1253.88	185.13	1232.28	189.81	1220.40	192.32	1197.72	197.90	1184.76	201.19	1158.84	207.76
12.00	/	/	/	/	1288.44	186.62	1270.08	191.21	1256.04	193.81	1235.52	199.76	1222.20	203.05	1195.56	209.62
13.00	/	/	/	/	/	/	1307.88	192.88	1293.84	195.67	1272.24	201.44	1259.28	204.79	1233.36	211.48
14.00	/	/	/	/	/	/	1350.00	194.00	1339.20	196.23	1310.04	203.11	1297.08	206.52	1271.16	213.34
15.00	/	/	/	/	/	/	1390.50	195.49	1381.32	197.72	1351.08	204.79	1337.76	208.26	1311.12	215.20

Note: The above parameters are in accordance with the 7 °C evaporator water outlet, 30 °C condenser water inlet.

MWSC1200A-FB3

Chilled Water Outlet Temp. (°C)	Cooling Water Inlet(°C)															
	25.00		26.00		27.00		29.00		30.00		32.00		33.00		35.00	
	Capacity	Power	Capacity	Power	Capacity	Power	Capacity	Power	Capacity	Power	Capacity	Power	Capacity	Power	Capacity	Power
	kW	kW	kW	kW	kW	kW	kW	kW	kW	kW	kW	kW	kW	kW	kW	kW
5.00	1180.80	191.37	1170.40	193.43	1160.00	195.49	1138.20	200.03	1126.80	202.50	1106.40	208.27	1093.20	211.56	1066.80	218.15
6.00	1222.80	192.82	1210.80	194.94	1198.80	197.07	1174.80	201.78	1162.80	204.35	1142.40	209.91	1128.80	213.28	1101.60	220.01
7.00	1257.60	194.46	1246.40	196.59	1235.20	198.72	1212.00	203.43	1200.00	206.00	1174.80	211.77	1162.00	215.27	1136.40	222.27
8.00	1299.60	195.91	1287.60	198.03	1275.60	200.16	1251.00	204.97	1238.40	207.65	1213.20	213.62	1194.80	217.33	1158.00	224.75
9.00	1336.80	197.35	1325.60	199.48	1314.40	201.61	1290.60	206.62	1278.00	209.50	1251.60	215.48	1237.20	219.12	1208.40	226.39
10.00	1374.00	199.00	1364.40	201.19	1354.80	203.39	1329.60	208.37	1314.00	211.15	1290.00	217.54	1276.40	221.04	1249.20	228.04
11.00	/	/	1402.80	202.84	1393.20	205.04	1369.20	210.22	1356.00	213.00	1330.80	219.18	1316.40	222.82	1287.60	230.10
12.00	/	/	/	/	1431.60	206.69	1411.20	211.77	1395.60	214.65	1372.80	221.24	1358.00	224.88	1328.40	232.16
13.00	/	/	/	/	/	/	1453.20	213.62	1437.60	216.71	1413.60	223.10	1399.20	226.81	1370.40	234.22
14.00	/	/	/	/	/	/	1500.00	214.86	1488.00	217.33	1455.60	224.95	1441.20	228.73	1412.40	236.28
15.00	/	/	/	/	/	/	1545.00	216.51	1534.80	218.98	1501.20	226.81	1486.40	230.65	1456.80	238.34

Note: The above parameters are in accordance with the 7 °C evaporator water outlet, 30 °C condenser water inlet.

Flooded type water cooled screw chiller (PCB Control)

MWSC1385A-FB3

Chilled Water Outlet Temp. (°C)	Cooling Water Inlet(°C)															
	25.00		26.00		27.00		29.00		30.00		32.00		33.00		35.00	
	Capacity kW	Power kW	Capacity kW	Power kW	Capacity kW	Power kW	Capacity kW	Power kW	Capacity kW	Power kW	Capacity kW	Power kW	Capacity kW	Power kW	Capacity kW	Power kW
5.00	1362.84	221.10	1350.84	223.48	1338.83	225.86	1313.67	231.10	1300.52	233.95	1276.97	240.62	1261.74	244.43	1231.27	252.04
6.00	1411.32	222.77	1397.47	225.23	1383.62	227.69	1355.92	233.12	1342.07	236.10	1318.52	242.52	1302.82	246.41	1271.43	254.18
7.00	1451.48	224.67	1438.55	227.13	1425.63	229.59	1398.85	235.03	1385.00	238.00	1355.92	244.66	1341.14	248.71	1311.60	256.80
8.00	1499.96	226.34	1486.11	228.80	1472.26	231.26	1443.86	236.81	1429.32	239.90	1400.24	246.81	1379.00	251.09	1336.53	259.66
9.00	1542.89	228.00	1529.96	230.46	1517.04	232.92	1489.57	238.71	1475.03	242.05	1444.56	248.95	1427.94	253.15	1394.70	261.56
10.00	1585.83	229.91	1574.75	232.45	1563.67	234.99	1534.58	240.74	1516.58	243.95	1488.88	251.33	1473.18	255.37	1441.79	263.47
11.00	/	/	1619.07	234.35	1607.99	236.89	1580.29	242.88	1565.05	246.09	1535.97	253.23	1519.35	257.44	1486.11	265.85
12.00	/	/	/	/	1652.31	238.79	1628.76	244.66	1610.76	248.00	1584.44	255.61	1567.36	259.82	1533.20	268.23
13.00	/	/	/	/	/	/	1677.24	246.81	1659.23	250.38	1631.53	257.75	1614.91	262.04	1581.67	270.61
14.00	/	/	/	/	/	/	1731.25	248.23	1717.40	251.09	1680.01	259.90	1663.39	264.26	1630.15	272.99
15.00	/	/	/	/	/	/	1783.19	250.14	1771.42	252.99	1732.64	262.04	1715.55	266.48	1681.39	275.37

Note: The above parameters are in accordance with the 7 °C evaporator water outlet, 30 °C condenser water inlet.

MWSC1620A-FB3

Chilled Water Outlet Temp. (°C)	Cooling Water Inlet(°C)															
	25.00		26.00		27.00		29.00		30.00		32.00		33.00		35.00	
	Capacity kW	Power kW	Capacity kW	Power kW	Capacity kW	Power kW	Capacity kW	Power kW	Capacity kW	Power kW	Capacity kW	Power kW	Capacity kW	Power kW	Capacity kW	Power kW
5.00	1594.08	258.26	1580.04	261.04	1566.00	263.82	1536.57	269.94	1521.18	273.27	1493.64	281.06	1475.82	285.51	1440.18	294.40
6.00	1650.78	260.21	1634.58	263.08	1618.38	265.95	1585.98	272.30	1569.78	275.78	1542.24	283.28	1523.88	287.82	1487.16	296.90
7.00	1697.76	262.43	1682.64	265.30	1667.52	268.18	1636.20	274.53	1620.00	278.00	1585.98	285.78	1568.70	290.51	1534.14	299.96
8.00	1754.46	264.38	1738.26	267.25	1722.06	270.12	1688.85	276.61	1671.84	280.22	1637.82	288.29	1612.98	293.29	1563.30	303.30
9.00	1804.68	266.32	1789.56	269.20	1774.44	272.07	1742.31	278.83	1725.30	282.73	1689.66	290.79	1670.22	295.70	1631.34	305.52
10.00	1854.90	268.55	1841.94	271.51	1828.98	274.48	1794.96	281.20	1773.90	284.95	1741.50	293.57	1723.14	298.29	1686.42	307.75
11.00	/	/	1893.78	273.74	1880.82	276.70	1848.42	283.70	1830.60	287.45	1796.58	295.79	1777.14	300.70	1738.26	310.53
12.00	/	/	/	/	1932.66	278.93	1905.12	285.78	1884.06	289.68	1853.28	298.57	1833.30	303.48	1793.34	313.31
13.00	/	/	/	/	/	/	1961.82	288.29	1940.76	292.46	1908.36	301.07	1888.92	306.08	1850.04	316.09
14.00	/	/	/	/	/	/	2025.00	289.95	2008.80	293.29	1965.06	303.58	1945.62	308.67	1906.74	318.87
15.00	/	/	/	/	/	/	2085.75	292.18	2071.98	295.51	2026.62	306.08	2006.64	311.27	1966.68	321.65

Note: The above parameters are in accordance with the 7 °C evaporator water outlet, 30 °C condenser water inlet.

Flooded type water cooled screw chiller (PCB Control)

MWSC1780A-FB3

Chilled Water Outlet Temp. (°C)	Cooling Water Inlet(°C)															
	25.00		26.00		27.00		29.00		30.00		32.00		33.00		35.00	
	Capacity kW	Power kW	Capacity kW	Power kW	Capacity kW	Power kW	Capacity kW	Power kW	Capacity kW	Power kW	Capacity kW	Power kW	Capacity kW	Power kW	Capacity kW	Power kW
5.00	1751.52	284.27	1736.09	287.33	1720.67	290.39	1688.33	297.13	1671.42	300.80	1641.16	309.37	1621.58	314.26	1582.42	324.05
6.00	1813.82	286.42	1796.02	289.58	1778.22	292.74	1742.62	299.73	1724.82	303.55	1694.56	311.81	1674.39	316.81	1634.04	326.81
7.00	1865.44	288.86	1848.83	292.03	1832.21	295.19	1797.80	302.18	1780.00	306.00	1742.62	314.57	1723.63	319.77	1685.66	330.17
8.00	1927.74	291.01	1909.94	294.17	1892.14	297.33	1855.65	304.47	1836.96	308.45	1799.58	317.32	1772.29	322.83	1717.70	333.85
9.00	1982.92	293.15	1966.31	296.31	1949.69	299.47	1914.39	306.92	1895.70	311.20	1856.54	320.08	1835.18	325.48	1792.46	336.29
10.00	2038.10	295.60	2023.86	298.86	2009.62	302.12	1972.24	309.52	1949.10	313.65	1913.50	323.14	1893.33	328.34	1852.98	338.74
11.00	/	/	2080.82	301.31	2066.58	304.57	2030.98	312.27	2011.40	316.40	1974.02	325.58	1952.66	330.99	1909.94	341.80
12.00	/	/	/	/	2123.54	307.02	2093.28	314.57	2070.14	318.85	2036.32	328.64	2014.37	334.05	1970.46	344.86
13.00	/	/	/	/	/	/	2155.58	317.32	2132.44	321.91	2096.84	331.40	2075.48	336.91	2032.76	347.92
14.00	/	/	/	/	/	/	2225.00	319.16	2207.20	322.83	2159.14	334.15	2137.78	339.76	2095.06	350.98
15.00	/	/	/	/	/	/	2291.75	321.61	2276.62	325.28	2226.78	336.91	2204.83	342.62	2160.92	354.04



Note: The above parameters are in accordance with the 7 °C evaporator water outlet, 30 °C condenser water inlet.

10. Accessories

Standard accessories

NO.	Name	Quantity
1	User manual	1
2	Water pressure difference switch	1
3	Packing list	1

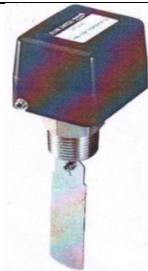
Optional Accessories

NO.	Name	Model	Instructions	Picture	Qty
1	Water flow switch	WFS-1001-H (Honeywell)	Installed on evaporator outlet pipe to prevent heat exchange pipe from frost crack.		2
2	Vibration damper	SHA-2600 (340/440/540kW) SHA-3200 (690~1780kW)	To avoid vibration and noise, it must be used between base and foundation when install the unit.		4
3	Remote control cabinet	GX03501	Can be installed in the control room. Through the cable connected to the unit touch screen, it can display all states information and complete all the operations of unit (startup/shutdown, error confirm, etc.)		1
4	Flange	Q235-B,150-10 (340/440/540kW) Q235-B,200-10 (690~1780kW)	Flange connection can be chosen for water pipe connection. Customer can choose water side pressure 1.6MPa according to requirement.		8

III. Control

1. Control flow chart

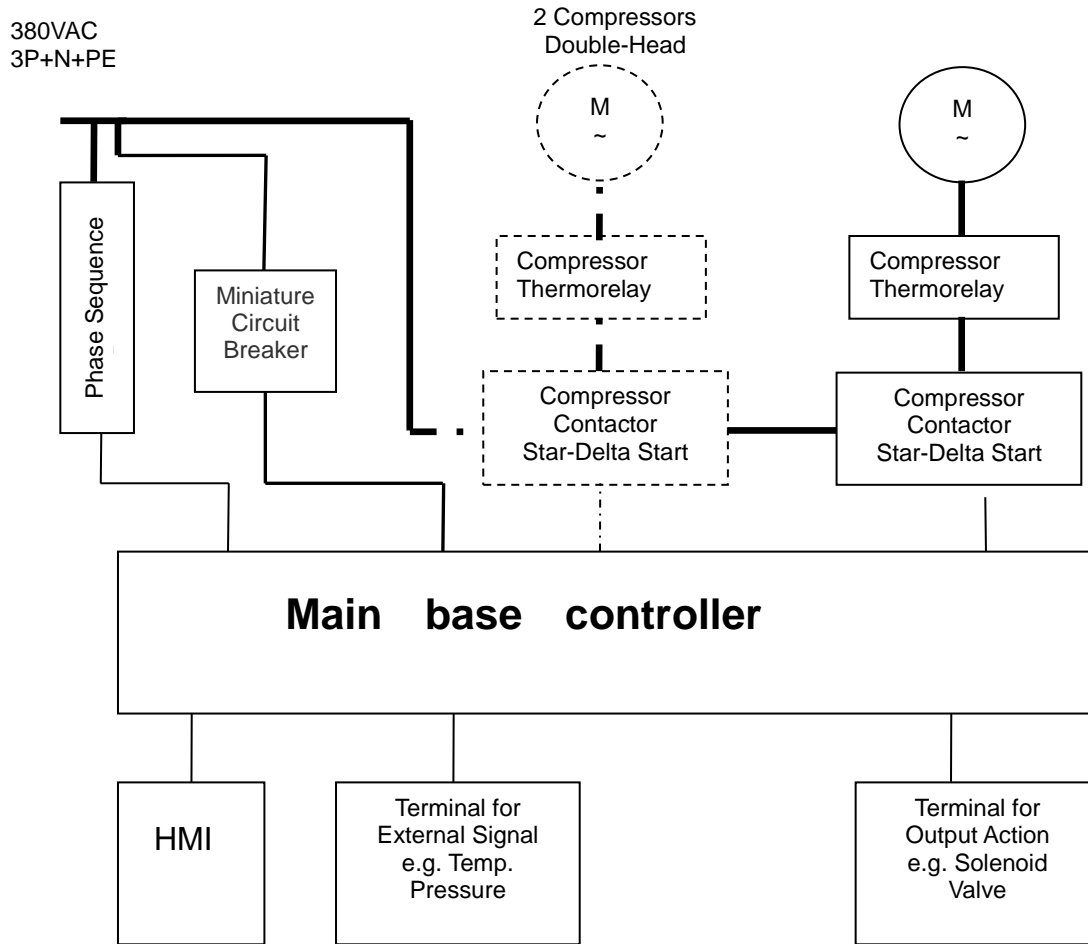

Main base controller gathers signals through input terminals, such as pressure, temperature and the state of protection switches and ensures unit's current condition. At the same time, according to input signal from HMI, such as starting signal, controller performs the logical operations and outputs signals. These signals act on components, time relay, contactors and so on.

HMI+ Main base controller:

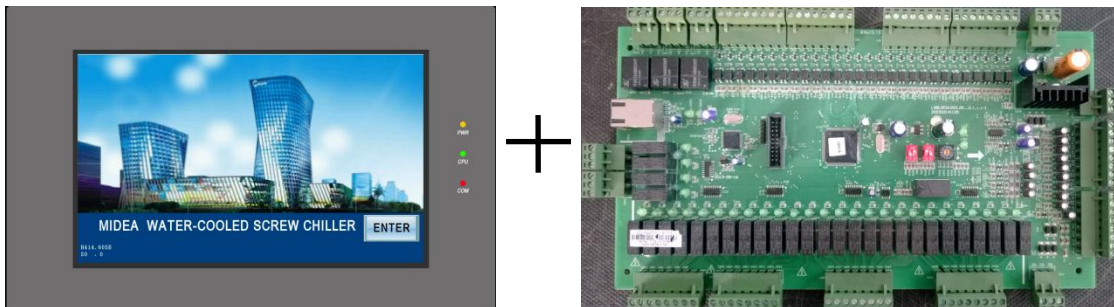

2. Energy adjustment

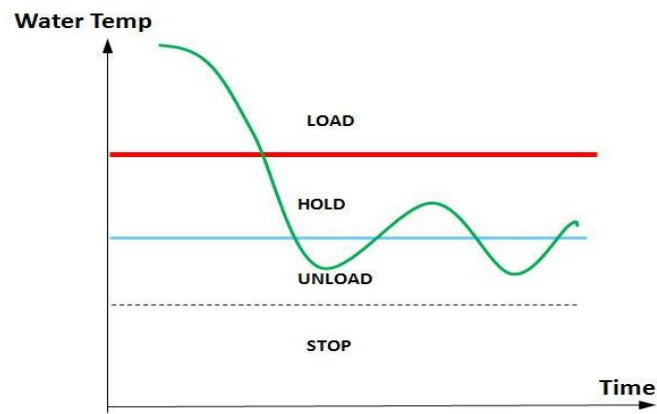

The unit adjust capacity by chilled water. The control logic see picture.

Energy adjustment is districted when starting high pressure is too high.

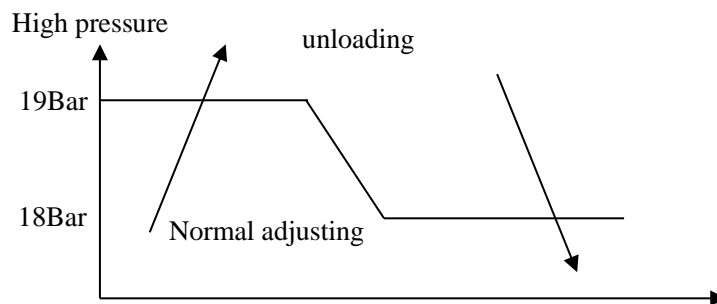

3. Start/stop process

1).cooling start

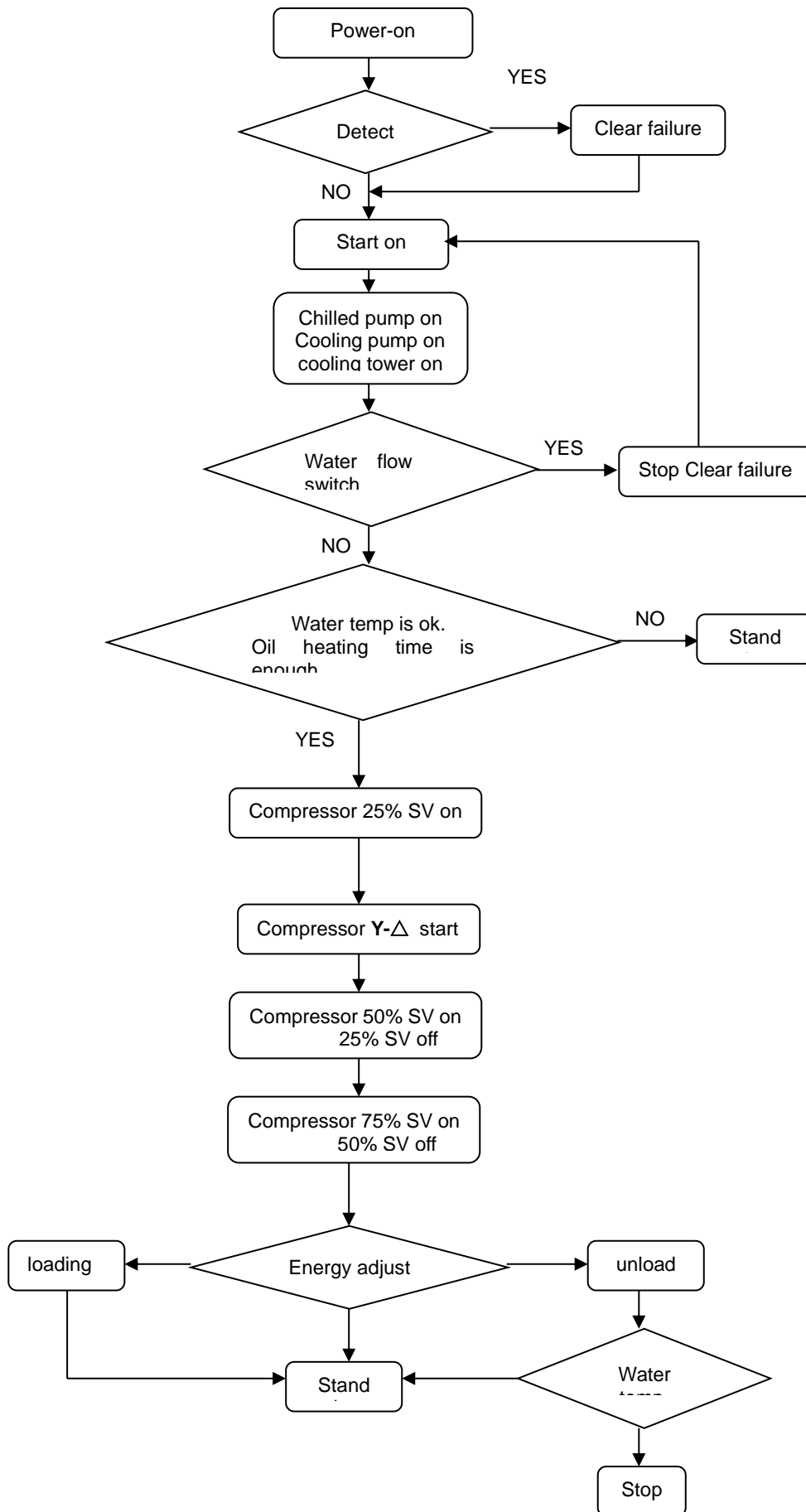

2).cooling stop

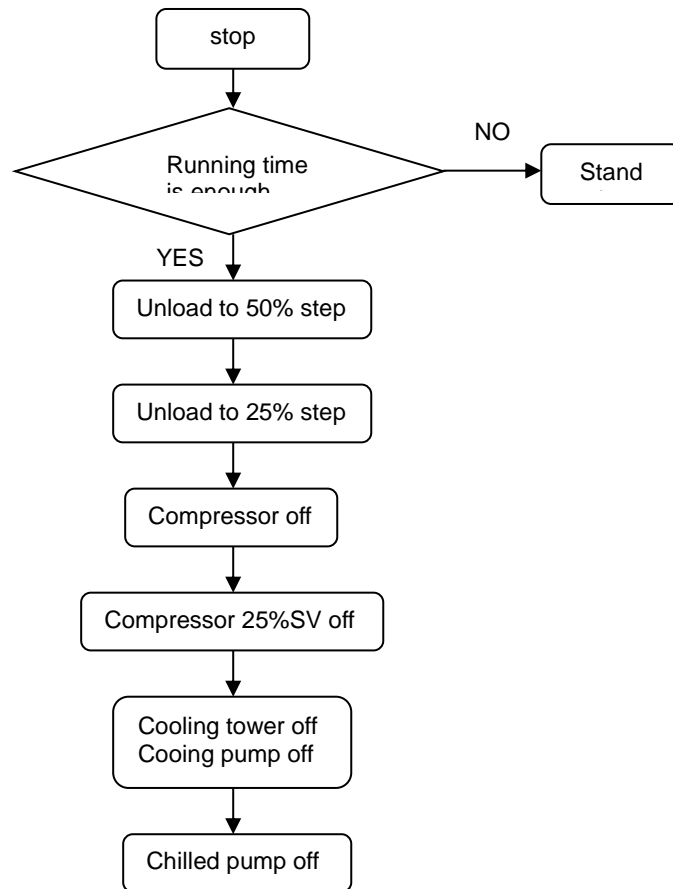

4. Sensors

1).Temperature sensors

The temperature sensors that unit use are all NTC thermistors, including chilled leaving water temperature, chilled entering water temperature, discharge temperature, EXV discharge temperature.

NO.	Name	Type	Remark	code
1	Chilled entering water temp.	NTC,10k@25°C	Emerson	202301300703
2	Chilled leaving water temp.	NTC,10k@25°C	Emerson	202301300703
3	Cooling entering water temp.	NTC,10k@25°C		
4	Cooling leaving water temp.	NTC,10k@25°C		
5	Discharge temp.			
6	EXV discharge temp.	NTC,10k@25°C	Carel	202301300561

✚ Thermistors

For PTC thermistors, resistances vary with various temperatures.

➤ Location

Motor thermistor locates in the motor winding and is connected to the compressor protection module which will cut off the main power when motor winding temperature exceeds 110 °C. Water temperature thermistors are installed in wells on chilled water inlet/outlet and cooling water inlet/outlet. Refer to the

electric control wiring diagram for detail connection information.

➤ **Thermistor replacement**

To Replace Thermistors RT1, RT2, RT3, RT4, RT5, or RT6 (Entering/Leaving chilled Water; Entering/Leaving cooling Water; Discharge Temperature; Oil temperature) — Disconnect appropriate connector from the PCB controller. New thermistors should be spliced to existing wiring close to the connector unless new connectors are required. Remove thermistor cable from harness. Remove and discard original thermistor from well. Insert new thermistor in well body to its full depth. Add a small amount of thermal conductive grease to thermistor probe and well. Tighten the screw to prevent thermistors from slipping out of the well.

➤ **To Service Compressor Motor Thermistors**

A thermistor is factory installed in each compressor. Connections for the thermistors are located in the compressor wiring box. 2 terminals are reserved for the thermistor: S1 and S2. Motor temperature is measured by leads connected to S1 and S2 terminal. The thermistors are not serviceable in the field. If the compressor motor thermistor fails, compressor replacement is required.

2).pressure sensors

The pressure sensors are pressure transmitters. Danfoss AKS3000 are used.



Water temp. thermistor



suction temp. thermistor



pressure transmitter AK3000

5. Parts control

1). Oil heater control

In unit sand by period, oil heater is energized to keep normal oil temperature. When unit starts, it is turned off.

Oil heating time limits:

- When cooling water inlet temperature $\geq 35^{\circ}\text{C}$ (real time value), oil heating time for first startup is 0.5h. If power down happens during operation and downtime is less than 8hrs, no heating time delay is needed when unit restarts. If it exceeds 8hrs, 0.5h heating time is need.
- When cooling water inlet temperature $\geq 30^{\circ}\text{C}$ (real time value), oil heating time for first startup is 1h. If power down happens during operation and downtime is less than 5hrs, no heating time delay is needed when unit restarts. If it exceeds 5hrs, 1h heating time is need.
- When cooling water inlet temperature $\geq 25^{\circ}\text{C}$ (real time value), oil heating time for first startup is 2hrs. If power down happens during operation and downtime is less than 3hrs, no heating time delay is needed when unit restarts. If it exceeds 3hrs, 1h heating time is need. If it exceeds 5hrs, 2hrs heating time is need.

- When cooling water inlet temperature $\geq 20^{\circ}\text{C}$ (real time value), oil heating time for first startup is 4hrs. If power down happens during operation and downtime is less than 1hrs, no heating time delay is needed when unit restarts. If it exceeds 1hrs, 2h heating time is need. If it exceeds 5hrs, 3hrs heating time is need. If it exceeds 8hrs, 4hrs heating time is need.
- When cooling water inlet temperature $< 20^{\circ}\text{C}$ (real time value), oil heating time for first startup is 8hrs. If power down happens during operation and downtime is less than 1hrs, no heating time delay is needed when unit restarts. If it exceeds 1hrs, 3h heating time is need. If it exceeds 5hrs, 5hrs heating time is need. If it exceeds 8hrs, 8hrs heating time is need.

**2). Pressure sensor Control
high pressure control**

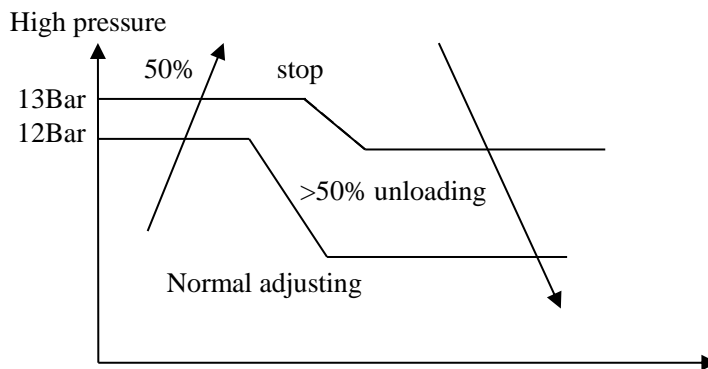

3). Discharge temp. Control

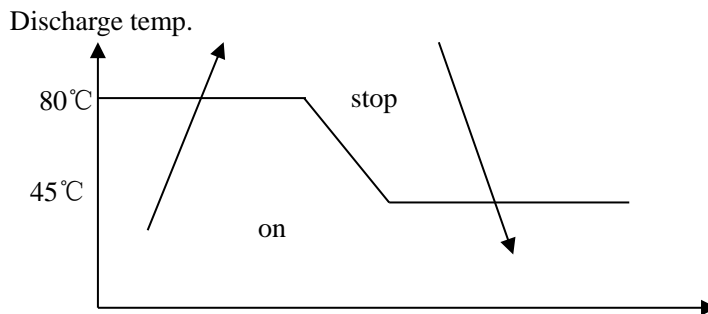

4). Return oil solenoid valve Control

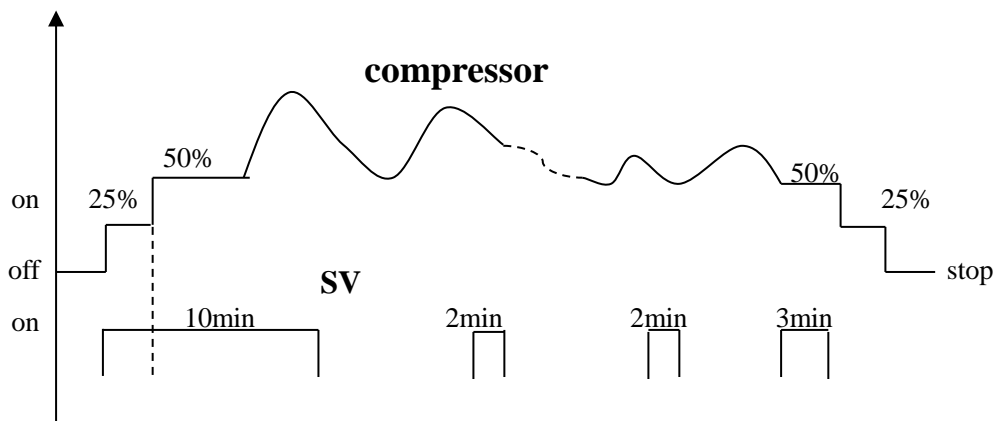

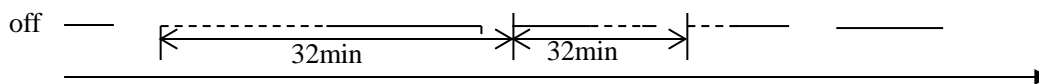

- a. When compressor start, the return oil solenoid valve is opened ,closed after 10 minutes.
- b. When compressor is running ,from compressor start to 50%,every 30 minutes to open return oil solenoid valve 2 minutes.
- c. When compressor shut down, with the compressor unloaded into 50% return oil solenoid valve open 3 minutes.
- d. When oil level protection occurs, the return oil solenoid valve is opened, closed after recovery.

5). EXV controller Control

a. EXV controller wiring principle

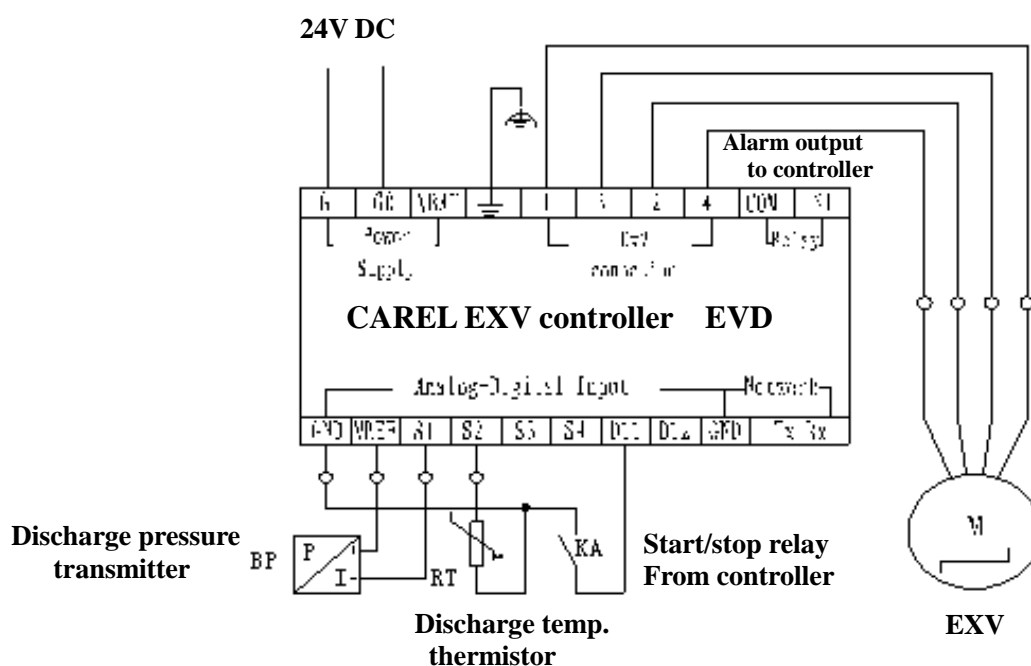

EXV controller is started by main base controller. It detects discharge pressure, temperature and calculate discharge superheat. Then it control EXV opening depending on superheat. If it is wrong .EXV will output alarm signal to main base controller.

b. Controller display

The interface of EXV controller cannot display and set the parameter on unit, only display running status.

LED	Light	Extinguish	Flicker
NET	Can be connected to the network	Not connected	Communication failure
OPEN	Open the valve	-	Disable the drive
CLOSE	Close the valve	-	Disable the drive
	Activate the alarm	-	-
	Drive power	The drive is not connected	-



		to power supply	
--	--	-----------------	--

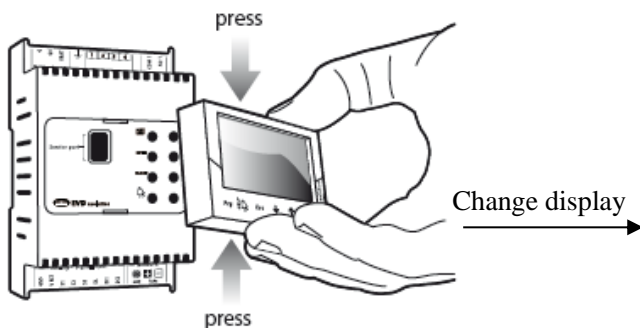
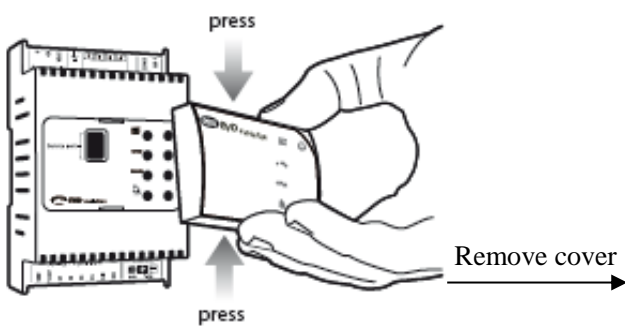

1	Display suction superheat
2	Display EXV opening
3	Relay output status
4	Alarm
5	Start of the protection

If the parameter need to be displayed and set. Interface should be changed.

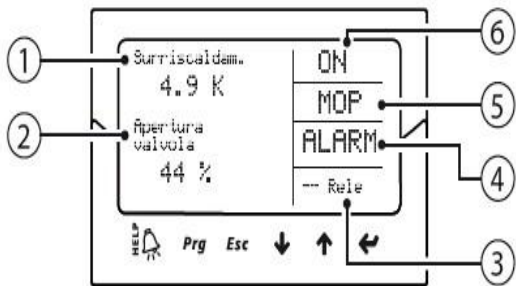

Display



Button	Function	6	Control state
Prg	Open the display screen, enter the password to enter the programming mode		
	<ul style="list-style-type: none"> In the alarm state, the display alerts the queue; When the "producer" level under the rolling parameters, the display shows the interface 		
Esc	<ul style="list-style-type: none"> To exit the programming (maintenance / producer) and display mode; set a parameter, the exit without saving changes 		
	<ul style="list-style-type: none"> Display screen navigation; Increase / decrease the value 		
	<ul style="list-style-type: none"> from the parameter setting mode, the display switches to Confirm the list of parameters and return the value 		

Running display status



display all status



Press  →
←
Press Esc button

c. Controller parameter checking and changing.

Checking or changing repair parameters step:

- ① Press one or more Esc to switch to the standard display interface;
- ② Press Prg: display interface input password;
- ③ Press ENTER input repair level password: 22, starting from the rightmost digit, each input a digital, confirm with ENTER ;



- ④ If the password is correct, will display the first parameters can be modified: network address;
- ⑤ Press UP/DOWN to select parameters should be set up;
- ⑥ Press ENTER to move to the parameter value;
- ⑦ Press UP/DOWN to modify the parameter value;

- ⑧ Press ENTER to save the new parameter values;
- ⑨ Repeat the above 5, 6, 7, 8 step change other parameters;
- ⑩ Press Esc to exit the repair parameters modify the program.

The following shows the detailed settings: 13 pages

Drive hardware configuration 1/13 Network address 198	Drive hardware configuration 2/13 Refrigerant type R134a Valve type Danfoss ETS 250
Drive hardware configuration 3/13 Type of probe S1 User-defined Unit type Fin coil evaporator air-conditioner	Drive hardware configuration 4/13 Type of probe S1 NTC Carel Auxiliary control type Disabled
Drive hardware configuration 5/13 Type of probe S3 Unused Relay configuration Generate alarms	Drive hardware configuration 6/13 Type of probe S4 Unused DI1 configuration Start/stop SH control
Drive hardware configuration 7/13 Language Chinese DI2 configuration Disabled	Control parameter settings 8/13 Overheat degree 6.0K Valve opening upon start 50% Pre-positioning duration 30s
Control parameter settings 9/13 Hot air by-pass temperature --- Hot air by-pass temperature --- EPR back pressure ---	Control parameter settings 10/13 LowSH 2.0K LOP -50 °C MOP 50 °C
Control parameter settings 11/13 Enable manual valve positioning 0 Manually set the valve position 0stp	Control parameter settings 12/13 HiTcond threshold 80.0 °C Constant temperature adjustment point 0 °C Constant temperature adjustment variance 0.1K

Checking or changing manufacturer parameters step:

- ① Press one or more Esc to switch to the standard display interface;
- ② Press Prg: display interface input password;
- ③ Press ENTER input manufacturer password, starting from the rightmost digit, each input a digital, confirm with ENTER ;
- ④ If the password is correct, will display the following parameter type list:
 - Configuration parameters
 - ensor parameters
 - Control parameters

- he special parameters
- lert configuration parameters
- Valve parameters



- ⑤ Press UP/DOWN button to select the category, and then press ENTER to enter the first class number
- ⑥ Press UP/DOWN to select parameters to be set, and then press ENTER to move to the parameter value;
- ⑦ Press UP/DOWN to modify the parameter value;
- ⑧ Press ENTER to save the new parameter values;
- ⑨ Repeat the above 6, 7, 8 step change other parameters;
- ⑩ Press Esc to exit the manufacturer parameter modification program.

Unit type		340,440,540,690,805,890,1080,1200,1385,1620,1780	Remarks
Setting parameters	Refrigerant	R134a	Selected based on the refrigerant type of the unit
	Valve	Danfoss ETS250	
	Sensor S1	4-20 mA; 0-10.0 V	Automatically brought out by subsequently set parameters
	Control mode	shell-and-tube unit	
	Overheat degree	6	
	Valve opening upon start	50%	
	Pre-positioning delay	6	
	Valve opening in standby state	0	
	Power supply mode	1	Available values include: (1) 0: 24 V AC (2) 1: 24 V DC; default value: 0
Check parameters	Enable manual valve positioning	0	
	Manually set the valve position	0	
	Auxiliary control	Invalid	
	Relay settings	Alarm relay	
	DI2 settings	Invalid	
	Variable 1 on the display	Overheat degree	
	Variable 2 on the display	Valve opened	
	Sensor S1 alarm management	Valve at a fixed position	
	Sensor S2 alarm management	Valve at a fixed position	
	S1: calibration offset	0	
	S1: calibration gain, 4–20 mA	1	
	Pressure sensor S1: minimum value	0	Set based on the actual sensor
	Pressure sensor S1: maximum value	30	Set based on the actual sensor
	Pressure sensor S1: minimum value for alarms	0	Set based on the actual sensor
	Pressure sensor S1: maximum value for alarms	30	Set based on the actual sensor
	Sensor S2	CAREL NTC	
Language	English		
Measurement unit	°C (K), barg		

PID: proportional gain	80	
PID: integration time	40	
PID: derivation time	1.5	
Minimum number of valve steps	350	
Maximum number of valve steps	3810	
Number of steps for valve closing	3970	
Valve rate	250	
LowSH protection: threshold	1	
LowSH protection: integration time	2.5	
LOP protection: threshold	-50	
LOP protection: integration time	4	
MOP protection: threshold	50	
MOP protection: integration time	10	
Low overheat degree alarm delay (LowSH, 0 = no alarm)	300	
Low evaporation temperature alarm delay (LOP, 0 = no alarm)	300	
High evaporation temperature alarm delay (MOP, 0 = no alarm)	600	
Low air suction temperature alarm threshold	-50	
Low air suction temperature alarm delay (0 = no alarm)	300	

6. Operation part

6.1 Unit operation flow chart

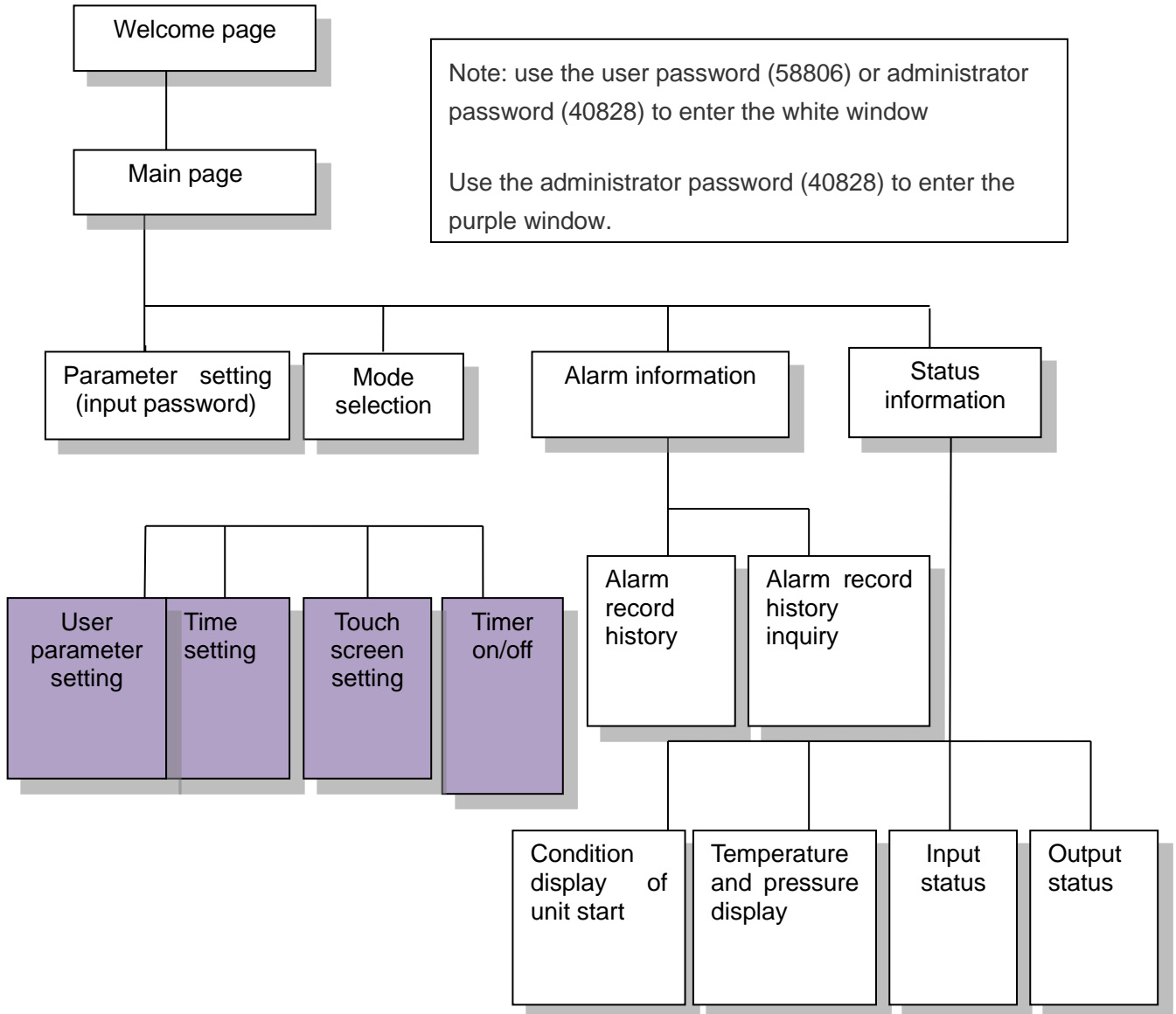

6.2 Operation part

The control system adopts touch screen, and all the operation is done on the screen directly. Take the unit with dual compressors and step control as example, the actual display of different product may have a little difference, but basically the operation is the same.

➤ Welcome page

The first welcome page as the figure 6.1

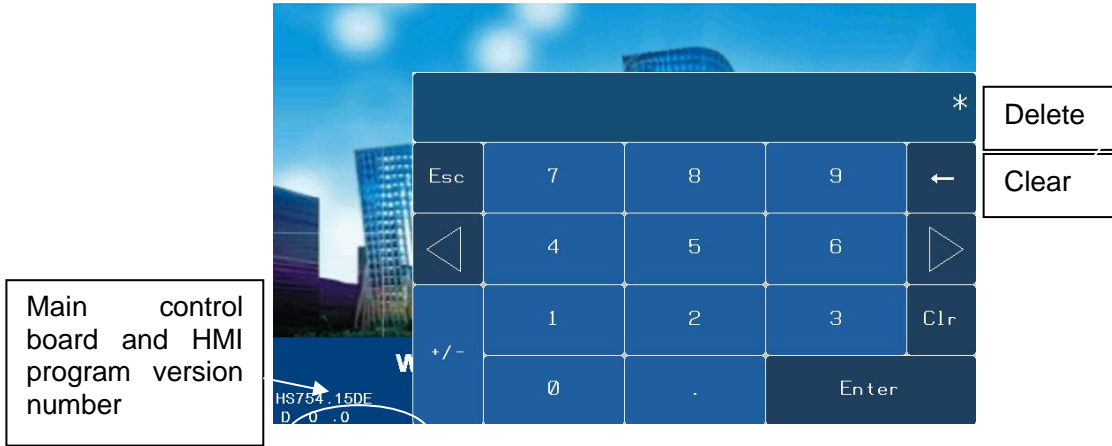

Figure 6.1

When press Enter button, password keyboard will appear. User input 58806/40828 and press Enter button to enter the main page.

Indicators explanation on the right are as following:

Yellow indicator is the power indicator. It keeps lighting under normal condition, if it is not light, please check if the power supply wiring is correct.

Green indicator is the touch screen operation indicator, under normal condition it flashes with low frequency.

Red indicator is communication indicator, under normal condition it flashes with high frequency, if not, please check if the communication wire connected with the main control board is connected properly and tightly.

➤ Main page

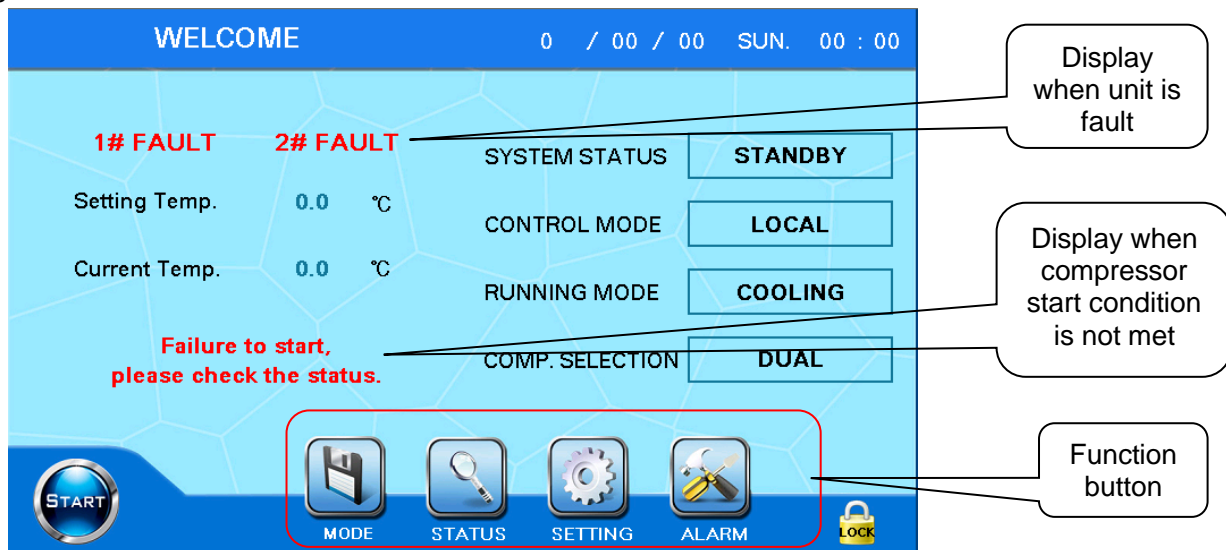

Figure 6.2

The main page displays the current status, control mode and operating mode of the unit.

Press **LOCK** button at the bottom right of the screen, and machine enters the initial screen, user needs to input password again to enter.

Refers to the below table for the current status displaying and explanation of the unit::

Standby	Machine is not operating, it can start normally.
Malfunction	Machine has malfunction and it cannot start. Please check from malfunction query page and confirm if the malfunction has been solved.
Operating	Machine is operating normally
Starting	Machine starts to normal operation
Shutting down	Unload, stop the compressor and stop the water pump are the necessary process during shutting down. If the minimum running time is not reached, it needs to wait until the minimum running time has been reached. Please inspect in the first page of status information if the minimum running time is satisfied. The shutting down process will be continued when minimum running time is satisfied.
Pause	The compressor startup conditions are not satisfied. The compressor startup condition includes: <ol style="list-style-type: none"> 1. Water temperature is not satisfy with compressor startup condition; 2. Water temperature needs to be higher than compressor startup temperature in cooling mode, Water temperature needs to be lower than compressor startup temperature in heating mode, this temperature can be modified in the parameter settings page; 3. Oil temperature of compressor is not satisfy with startup condition; 4. The pausing time is too short, and it is not meet the requirements of the compressor starts intervals; <p>The above information can be check in the first page of status information. The unit starts automatically when startup conditions are satisfied.</p>

1) Mode setting

Press **MODE** button and mode settings window will be pop-up, as shown in the below:

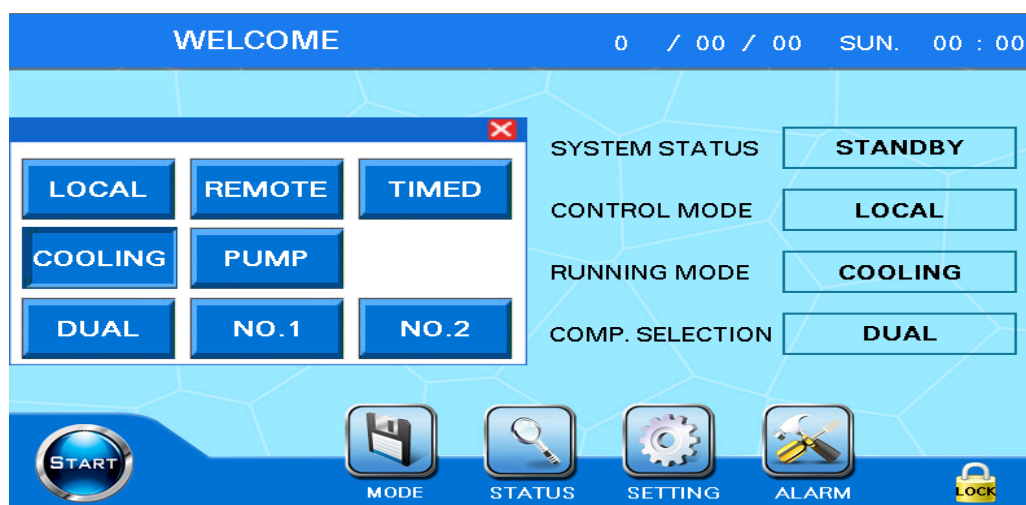

Figure 6.3

Set control mode(Local, remote, timer),operating mode(cooling, heating, pumping) and single or dual compressor(dual stage, 1#, 2#) in the pop-up window. After setting is finished, click the pop-up window

"X" at the top right to close the pop-up window.

- ① Only control mode can be switched during operating, other mode selection is invalid.
- ② The control mode is used as on/off mode choice. "Local" control mode can only be realized through the touch screen "on / off" button; "Remote" control mode can only be realized through the "remote start / remote stop" hardware interface; "the timer control mode", it can be only realized by setting the timer.
- ③ Heating mode is only available for the heat pump unit.

Note: under the "local" control mode, remote control and timer control are invalid; under the "remote" control mode, local control and timer control are invalid; under the "timed" control mode, local control and remote control are invalid.

2) Startup operation

It needs to confirm below before startup:

- ① Mode setting is correct. Operation mode (cooling, heating, pumping) and single/dual compressor (dual stages、 1#、 2#) cannot be set after startup.
- ② Current status of machine is standby, it cannot startup under malfunction status.
- ③ Please confirm if the oil heating is complete. If not, machine may stay in a pause state for a long time and compressor cannot start.

Press "start" button at bottom left of screen, pop-up window will appear. If confirm startup, please press "confirm"; if not, please click the pop-up window "X" at the top right to cancel startup.

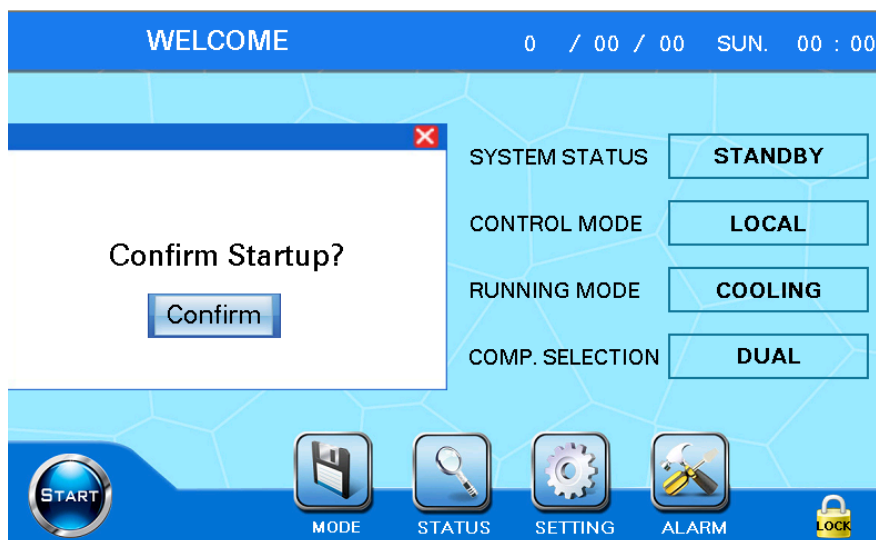

Figure 6.4

If the startup conditions are not satisfied, press "Start" button will display the prompt at the top of the pop-up boot window, it shows that "compressor start conditions are not met, please check status information". The compressor startup conditions include: temperature of oil temperature sensor, interval time of restart, startup temperature of compressor and so on. The startup can be confirmed right now, but unit will start until the compressor startup conditions are met, otherwise the main page will keep displaying that "compressor start conditions are not met, please check status information" . Please refers to the detailed explanation in the "4" for explanation of status information.

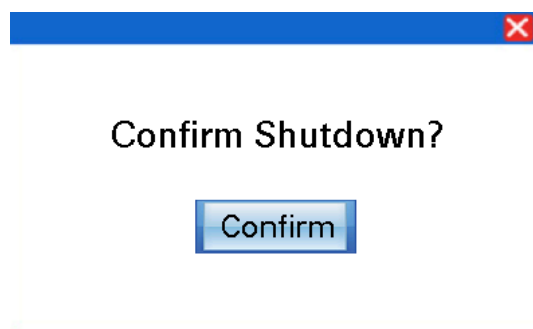
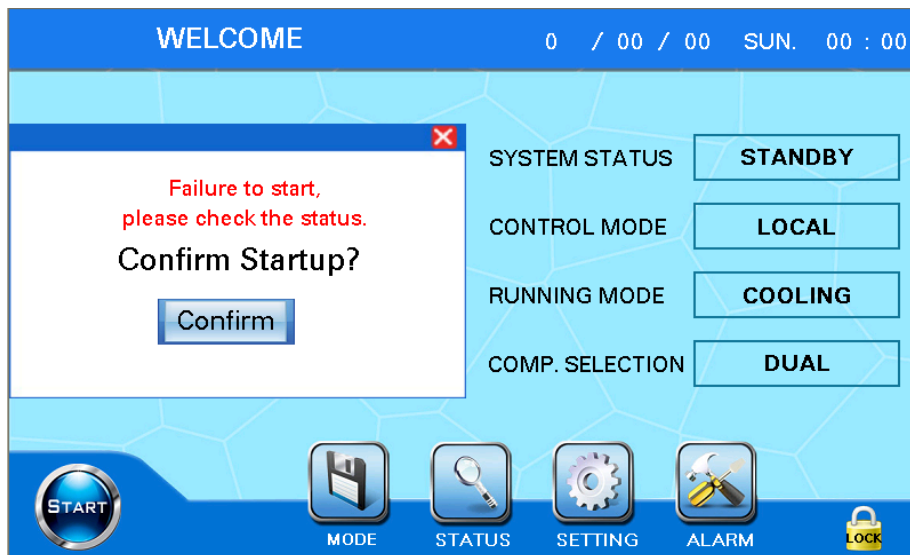

Figure 6.5

Startup operation: Press “startup” is not valid if unit is in malfunction state.

Press **START** button, and confirm in the pop-up window for startup, then unit can start.

If the compressor startup conditions are not satisfied, the unit goes into a pause state after running the water pump. The interface display "compressor start conditions are not satisfied, please check state information".

Shutdown operation:

Press the **STOP** button, pop-up window for shutdown confirmation will display. Press **Confirm** button, then unit status display "stop". After the unit is satisfied with the stop condition, it will carry out the shutdown process.

Standby status: machine is powered on, it will display “standby status” normally.

- ① Unit operation: the start-up of the unit is finished.
- ② Pause state: Control water temperature to be lower than water temperature of paused state. The unit enters “pause state” and compressor stops operating. Control water temperature to be higher than water temperature of compressor starting, compressor starts and enters “operating state”.
- ③ Shutting down : the unit enters “shutting down” state when carry out operation of shutdown to the unit. After shutdown is finished, unit enters “standby state”.
- ④ Unit protection : when the unit appears fault alarm, it enters “unit protection” state, and on the top of the screen will inform user which unit has malfunction.

Note:

Cooling mode: water temperature of paused state = setting chilled water temperature- temperature control range. When unit is in paused state, if temperature controlling is higher than compressor starting

temperature, compressor starts.

Heating mode: water temperature of paused state= setting chilled water temperature+ temperature control range. When unit is in paused state, if temperature controlling is lower than compressor starting temperature, compressor starts.

➤ Status information- operation query

Press **status** in the figure 6.5 and enter figure 6.6.

STATUS				
1#Comp. Running	0	H	1# Times for Comp.Start	0
2#Comp. Running	0	H	2# Times for Comp.Start	0
Pump Running	0	H		
1#ALARM	YES		1#Load State	0 %
2#ALARM	YES		2#Load State	0 %
1#Restart Delaying	YES		1#Load Limited	NO
2#Restart Delaying	YES		2#Load Limited	NO
1#Min. Running Time Elapsed	NO			
2#Min. Running Time Elapsed	NO			
Water Temp. Allow Compressor Start	NO			
STATUS	TEMP./PRES.	INPUT	OUTPUT	MAIN

Displaying of unit without oil temperature sensor

STATUS				
1#Comp. Running	0	H	1# Times for Comp.Start	0
2#Comp. Running	0	H	2# Times for Comp.Start	0
Pump Running	0	H		
1#ALARM	YES		1#Load State	0 %
2#ALARM	YES		2#Load State	0 %
1#Restart Delaying	YES		1#Load Limited	NO
2#Restart Delaying	YES		2#Load Limited	NO
1#Min. Running Time Elapsed	NO		1#Oil Temp. Allow Compressor Start	NO
2#Min. Running Time Elapsed	NO		2#Oil Temp. Allow Compressor Start	NO
Water Temp. Allow Compressor Start	NO			
STATUS	TEMP./PRES.	INPUT	OUTPUT	MAIN

displaying of unit with oil temperature sensor

Figure 6.6

Displaying contents of status information including the following:

- ① Display refrigerant type of the unit;
- ② Display operating time of compressor and water pump;
- ③ Display times that compressor starts;
- ④ You can check which state the unit operates in (25%、 50%、 75%、 100%) ;
- ⑤ Display if unit has been set with a limit of maximum load;
- ⑥ Display if unit gives an alarm, and which unit head gives the alarm exactly;
- ⑦ Display if the compressor oil heating is finished. If compressor starts, It need to be satisfied that oil heating time is ' 0 'or oil temperature is satisfy with compressor start" is ' Y E S ';

- ⑧ Display if the starting temperature is satisfied, when compressor starts, it need to be satisfied that water temperature is satisfied with “compressor start” is ‘Y E S’;
- ⑨ Display if the delay restart is satisfy, when compressor starts, it need to be satisfied that “delay restart” is ‘N O’;
- ⑩ Display if the minimum operation time is satisfy, when compressor stops, it need to be satisfy that “Min. Running Time Elapsed” is ‘Y E S’.

Note: when the compressor has oil temperature sensor, it displays that the oil temperature is satisfied with compressor start. When it has no oil temperature sensor, it displays the remaining time of oil heating. It depends on the unit

It displays the refrigerant type on the top left of the screen.

To start the unit must meet the following conditions:

- ① “Delaying Restart” need to be “NO”, if it is “YES”, the delay time to start the unit is not reached.
- ② “Water Temperature Allow Compressor Start” need to be “YES”, if it is “NO”, that means the current water temperature is not satisfied with the startup condition of compressor.
- ③ “Oil Temp. Allow Compressor Start” need to be “YES”, if it is “NO”, that means the current oil temperature is not satisfy with the startup condition of compressor.

Shutdown must meet the following conditions:

“Min. Running Time Elapsed” need to be “YES”, if it is “NO”, the delay time of shutdown is not reached.

1) Status information- display of temperature and pressure

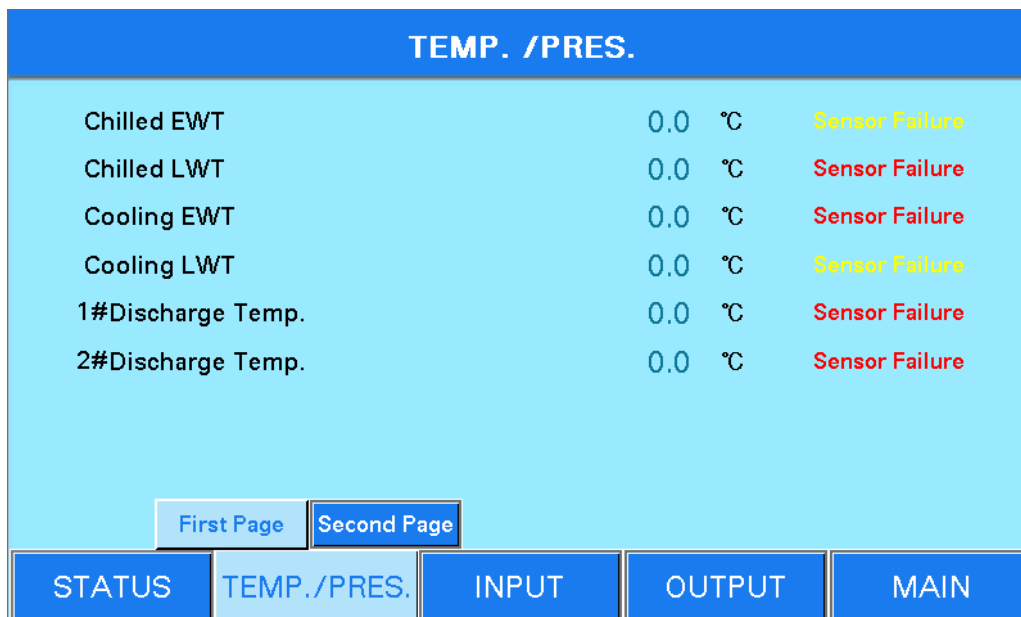

Figure 6.7

2) Status information-input status:

Input status page: “ON” represents the input point is closed, OFF represents the input point break. “Compressor overload protection switch”, when the machine is overload, “compressor overload protection switch” input state switches to “ON” and unit enters fault protection state. Normal state of compressor overload protection switch is “OFF”, and normal state of rest protections is “ON”.

INPUT			
Remote Start	ON	Chilled Water Switch	ON
Remote Stop	ON	Cooling Water Switch	ON
1#High Pres. Switch	ON	2#High Pres. Switch	ON
1#Low Pres. Switch	ON	2#Low Pres. Switch	ON
1#Motor Prot. Switch	ON	2#Motor Prot. Switch	ON
1#Oil Level Switch	ON	2#Oil Level Switch	ON
1#Contactor Prot.	ON	2#Contactor Prot.	ON
1#Comp. Overload Prot. Switch	ON	2#Comp. Overload Prot. Switch	ON
Power Prot. Switch	ON		

STATUS TEMP./PRES. INPUT OUTPUT MAIN

Figure 6.8 (Remark: subject to the actual principle diagrams)

- ① “Remote start/stop”, it displays the status of remote start or remote stop. User needs to install the point contact type control switch.
- ② “Chilling/Chilled water flow switch”, it outputs is OFF if water don’t flow, on the contrary, it outputs ON.
- ③ “Contactor protection”, the output switches from OFF to ON when the compressor operates and contactor has action.

3) Status information-output status

Output status page: ON represents the output point is powered on, OFF represents the input point is powered off.

When the unit is in a shutdown state, all state display is OFF. According to the startup / shutdown command, the relative switch action is activated.

OUTPUT			
Chilled Water Pump	OFF	Cooling Water Pump	OFF
1#Running	OFF	2#Running	OFF
1#ALARM	OFF	2#ALARM	OFF
1#Compressor	OFF	2#Compressor	OFF
1#25%SOL. Val.	OFF	2#25%SOL. Val.	OFF
1#50%SOL. Val.	OFF	2#50%SOL. Val.	OFF
1#75%SOL. Val.	OFF	2#75%SOL. Val.	OFF
1#Oil Return SOL. Val.	OFF	2#Oil Return SOL. Val.	OFF
Cooling Tower Fan	OFF		

STATUS TEMP./PRES. INPUT OUTPUT MAIN

Figure 6.9 (Remark: subject to the actual principle diagrams)

➤ User parameter setting- password interface

Press **Parameter setting** in the main page, then password input interface appears. Input the password (40828) and enter the user parameter setting interface. Password input interface is shown as figure 6.10.

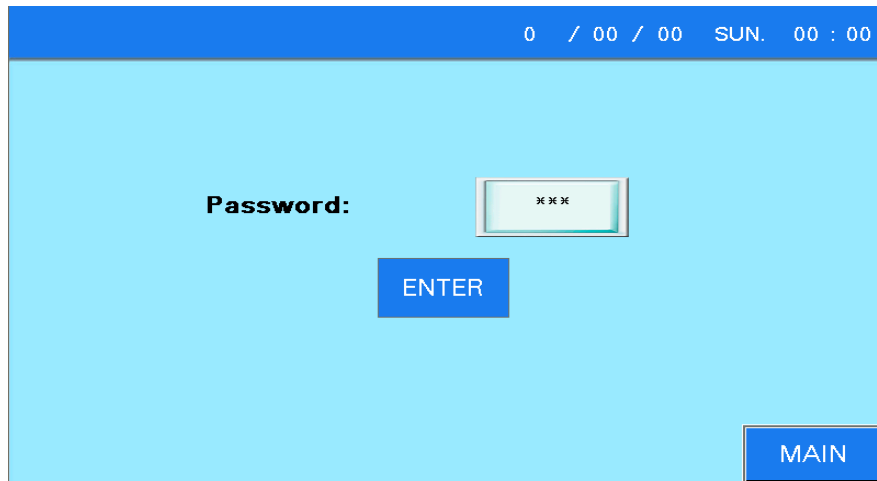

Figure 6.10

Dialog box like figure 6.11 appears if user inputs wrong password. Press **Confirm** button and go back to the input interface, then input password again.

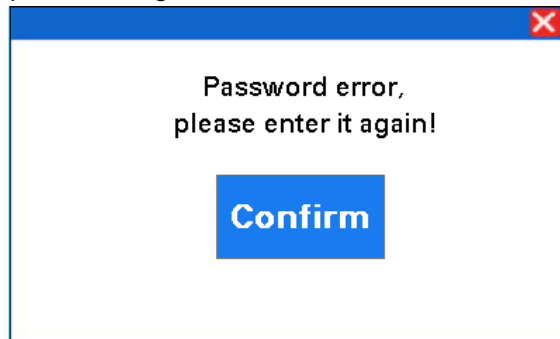
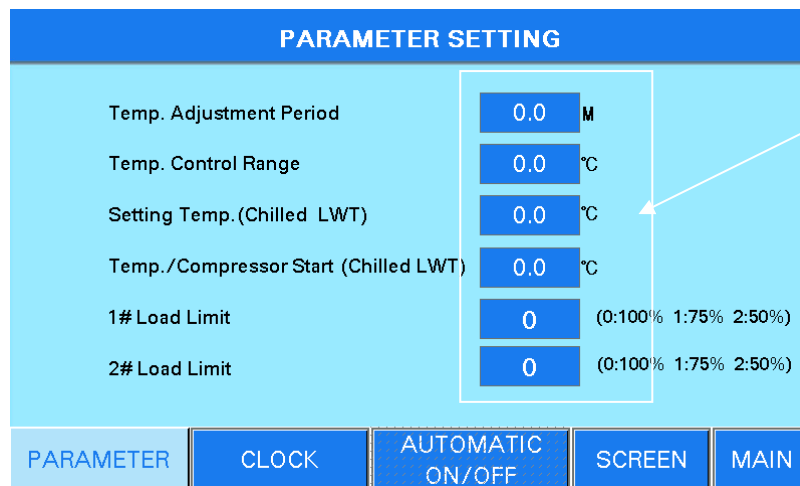

Figure 6.11

➤ User parameter setting-temperature setting

Input the password (40828) and enter the page as figure 6.12 as below:



Manual input is possible

Figure 6.12

“MAX” at the top left of setting window is upper limit of parameter setting, and “MIN” is lower limit of parameter setting (out of range is not accepted). Press **Enter** button to confirm input. Press **CLR** button to cancel input, then the keyboard for number input disappears.

Noun explanation

① The temperature adjustment cycle :it represents each execution cycle of the judgment of load or unload. If it is set to be 60S, that means every 60 seconds system judges the unit temperature and check if it needs to load or unload. If it is necessary, system will execute it immediately. After 60 seconds, system judges it again, and repeats the process like this;

② Temperature control range: it means the precision of temperature control, for example, the factory setting is 2℃,if temperature is within $\pm 0.5^{\circ}\text{C}$ of control temperature, the unit does not execute the loading/unloading action;

③ The target value of temperature control: it represents the target value of water temperature control;

④ Temperature of compressor startup: it represents the control water temperature need to meet one condition when compressor starts;

⑤ In cooling mode, when control water temperature is higher than startup temperature, the compressor can start; in heating mode, when control water temperature is lower than startup temperature, the compressor can start;

⑥ Limit of load: the maximum load of unit can be set. 0-without limit of maximum load, 1- maximum load is up to 75%, 2- maximum load is up to 50%.

Timer setting of startup or shutdown Only when control mode is “timer”, it will display.

1)User parameter setting-mode selection

Press **Clock** and enter the clock setting page as figure 6.13.

Click the setting numerical keyboard, then the input numerical keyboard appears. Input the clock and press “ENT” to save the setting. “CLR” represents the input is canceled.

Press **Confirm** button after setting finish, check if the setting clock is the same with the current time. If it is different, press **Confirm** again.

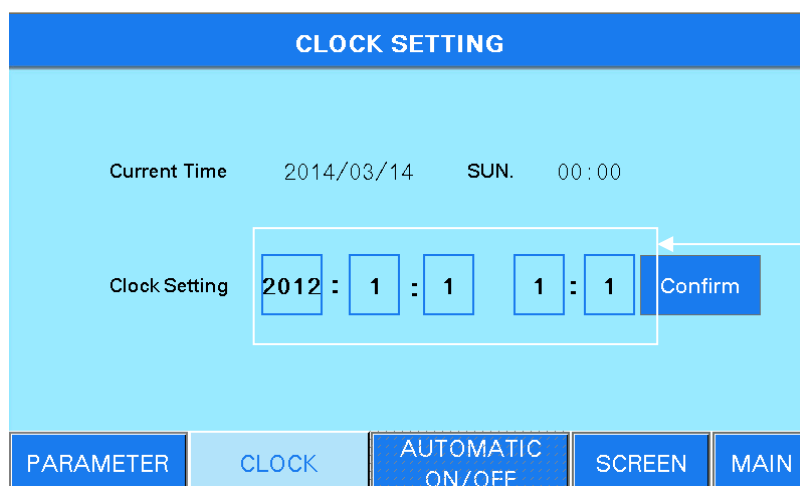

Figure 6.13

Note: when setting date and clock, please note the non-existent date and clock cannot be set, otherwise we are not responsible for any consequences.

2) User parameter setting-touch screen setting

User setting- press **touch screen setting** in the mode setting interface, then the following figure 6.14 will

appear.

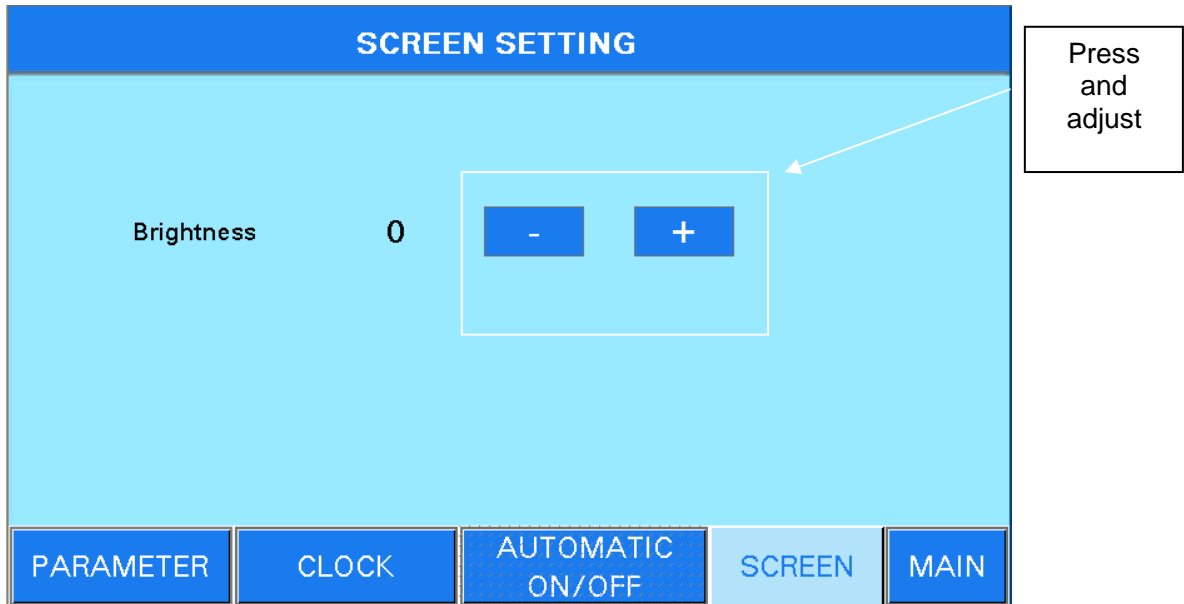

Figure 6.14

3) User parameter setting- Automatic On/Off

If user wants to use timer function of start or shutdown, it needs to choose “timer” in control mode of the figure 2 and enters user setting. Press **AUTOMATIC ON/OFF** and enter figure 6.15 as below:

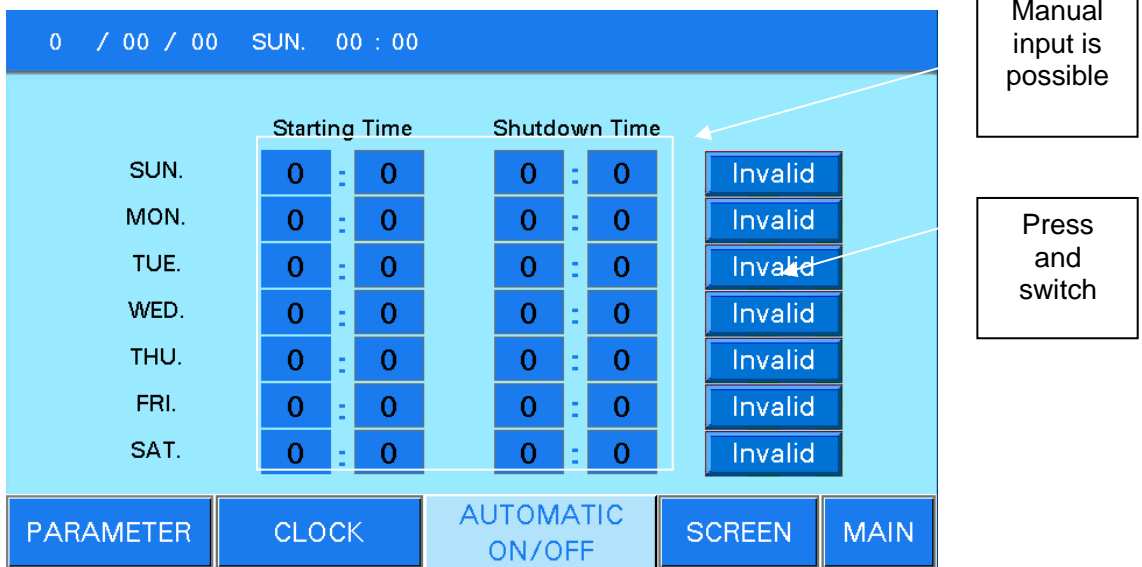

Figure 6.15

Timer of starting and shutdown in one week can be set, and unit will start or shutdown according to the timer setting. If the unit needs to continue running for a period, for example: start from Tuesday 10:00 and shutdown at 16:00 Thursday, user can set as 10:00 and switch the button from **Invalid** to **Valid** in the timer starting setting of Tuesday, then set as 16:00 and switch the button from **Invalid** to **Valid** in the timer shutdown setting of Thursday, rest timer buttons are set as **Invalid**.

Please check the system time when using timer function because the timer starting and shutdown is according to the system time.

➤ Alarm window

Press **Alarm** button in the main page and enter real-time alarm window, as figure 6.16 below.

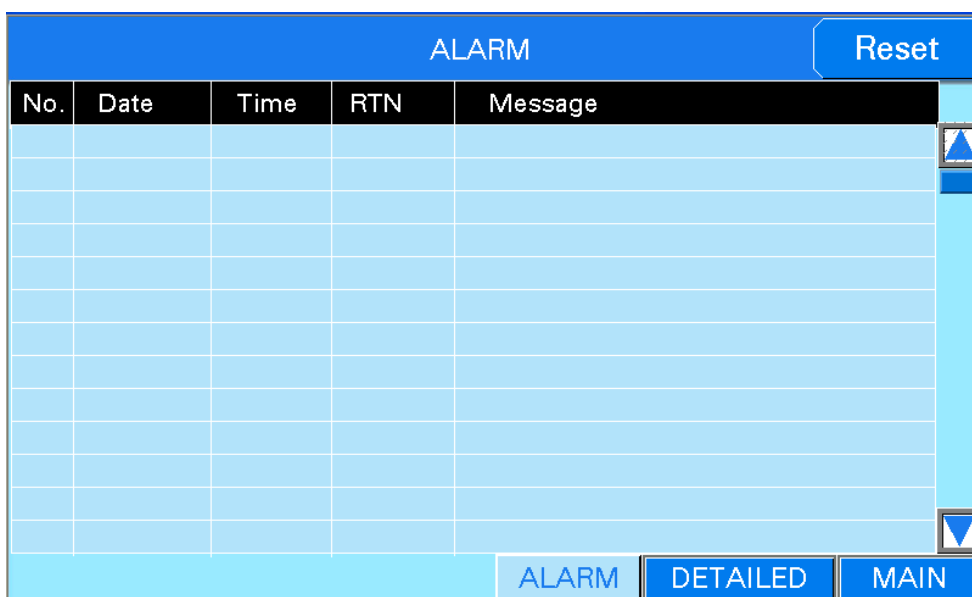

Figure 6.16

If the alarm happens, unit executes orders according to the fault program. After fault recovery, press the “reset” button, the system returns to normal state. When there are more faults, click the slide bar or arrow keys to check the faults. Red represents fault has not been eliminated, green represents fault has been eliminated.

Note:

- ①the high pressure protection cannot resume automatically, user needs to find the high pressure protection switch and reset it manually.
- ②the over load protection cannot resume automatically, user needs to find the thermal relay in the control cabinet and reset it manually.

1) Alarm history

Press the **Detailed** and enter record page, it records the alarms when compressor is running. As the figure 6.17 in the below: the alarm record can keep 5 pieces at most, it will update automatically if it is more than five. Check the real-time status including temperature, pressure, and status of input and output point.

Message		Alarm	
Warning Time: 2000 / 00 / 00 00 : 00		UP	NEXT
Chilled EWT	0.0 °C	Cooling EWT	0.0 °C
Chilled LWT	0.0 °C	Cooling LWT	0.0 °C
1#Discharge Temp.	0.0 °C	2#Discharge Temp.	0.0 °C
1#Discharge Pres.	0.0 Bar	2#Discharge Pres.	0.0 Bar
1#Suction Pres.	0.0 Bar	2#Suction Pres.	0.0 Bar

TEMP. /PRES. OUTPUT INPUT ALARM DETAILED MAIN

Message		Alarm			
Warning Time: 2000 / 00 / 00 00 : 00		UP	NEXT		
Chilled Water Pump	OFF	1#Running	OFF	2#Running	OFF
Cooling Water Pump	OFF	1#Compressor	OFF	2#Compressor	OFF
Cooling Tower Fan	OFF	1#25%SOL. Val.	OFF	2#25%SOL. Val.	OFF
1# ALARM	OFF	1#50%SOL. Val.	OFF	2#50%SOL. Val.	OFF
2# ALARM	OFF	1#75%SOL. Val.	OFF	2#75%SOL. Val.	OFF
		1#Oil Return SOL. Val.	OFF	2#Oil Return SOL. Val.	OFF

TEMP. /PRES. OUTPUT INPUT ALARM DETAILED MAIN

Figure 6.17

Please refers to the actual operation interface; it is subject to change without notice.

7. Safety protection

Name	Code	Brand	Setting Range	Location
Low-pressure Switch	YK-0.3/0.20-O-R-7000	JUNLE	ON 0.10Mpa OFF 0.20Mpa	
High-pressure Switch 1	YK-1.4/0.9-C-R-7000	JUNLE	ON 1.4Mpa OFF 0.9Mpa	

Note: Manual reset is needed for high-pressure switch.

Safety Devices

➤ Compressor protection module

The units are equipped with compressor protection modules built in the wiring cabinet of compressor. INT69 HBY and JTX-A module is designed to detect the motor winding temperature, phase sequence and phase loss. The detecting signal of JTX-A is voltage type. When motor winding temperature reaches set point, the module will cut off control circuit immediately. The module with phase sequence control can prevent motor reversal due to the adverse consequences. When any one phase loses, the module will cut off main power after a short delay to protect the motor from burning. When phase unbalance happens, it cuts the power immediately. In order to avoid interference and discriminate between false voltage drop and malfunction as phase loss or phase unbalance during motor operating, JTX-A will cut off main power after 3-5s delay.



➤ Thermal overload relay

Each compressor is equipped with one thermal overload relay to protect the compressor against overcurrent. Bypass the current transducers or make any changes to the factory default set points is forbidden. The configuration of the module defines the Must Trip Amps (MTA) at which the thermal overload relay will turn the compressor off.

➤ **High/low pressure switch**

All compressors have factory-installed high/low-pressure switches. See Table.6.10

Table – High/low-pressure switch settings

UNIT	High-pressure switch setting		Low pressure switch setting	
	Protection value	Reset Value	Protection value	Reset Value
MWSC_A-FB3	14bar	9bar	1bar	2bar

Table.6.10

If the high pressure switch continuously opens for 3s during operation, the compressor will be shut down. A manual reset of the control is required to restart the compressor. If the low pressure switch continuously opens for 1s during operation, the compressor will be shut down. It will reset automatically when malfunction gets solved and cleared on the malfunction record page of touch screen. Sometimes if the malfunction cannot be solved by reset, consider replace the pressure switches.

➤ **Evaporator protection-Low Chilled Leaving Water Temperature**

PCB is programmed to shut the chiller down if the leaving water temperature drops below 4 °C. When water temperature rises up to 10°C, the safety resets and the chiller restarts. Besides, the chillers are equipped with antifreeze switch which located on the outlet of chilled water. If leaving water temperature continuously keeps lower than 3 °C for 3s during operation, the chiller will be shut down. When water temperature rises up to 10 °C, the chiller resets, but it needs manually reset on the touch screen.

IMPORTANT: If unit is installed in an area where ambient temperature may fall below 32 F (0° C), a suitable corrosion-inhibited antifreeze solution or auxiliary electric heater must be used in the chilled water circuit.

IV. Electrical control

1. Electrical data

LSBLGWXXX/MCF		365	465	560	750	825	925	1120	1230	1500
Standard voltage	V	380V~3Ph~50Hz+N+PE								
Voltage range	V	342~418								
Max. running current	A	162	200	236	311	354	380	472	518	622
Max. power consumption	kW	93.5	116.8	141.9	182.9	205.8	222	283.8	215.8	365.8
Rated current	A	106	133	162	208	253	266	324	359	417
Compressor A										
Locked rotor Amps.	A	810	875	1340	1990	810	875	1340	1430	1990
Max. allowed current	A	219.6	274.3	333.2	429.5	241.6	260.7	333.2	369.6	429.5
Rated current	A	106	133	162	208	126.5	133	162	179.5	208.5
Rated power	kW	62	78	95	126	74	78	95	105	126
Compressor B										
Locked rotor Amps.	A	--	--	--	--	810	875	1340	1430	1990
Max. allowed current	A	--	--	--	--	241.6	260.7	333.2	369.6	429.5
Rated current	A	--	--	--	--	126.5	133	162	179.5	208.5
Rated power	kW	--	--	--	--	74	78	95	105	126
Crankcase heater										
Voltage	V	220	220	220	220	220	220	220	220	220
Total input	kW	0.3	0.3	0.3	0.3	0.6	0.6	0.6	0.6	0.6
Total Amps.	A	1.36	1.36	1.36	1.36	2.72	2.72	2.72	2.72	2.72

Note:

1. Customer to specify the exact nominal power supply available at site so that electrical components are selected accurately.
2. Main power must be supplied from a single field supplied and mounted fused circuit breaker.
3. The compressor crankcase heaters must be energized for hours before the unit is initially started or after a prolonged power disconnection.
4. All field wiring must be in accordance with local standards.
5. Neutral line required on 380V-3Ph-50Hz(5 wires) power supply.
6. Rated load Amps values are on nominal conditions.
7. The $\pm 10\%$ voltage variation from the nominal is allowed for a short time not permanent.

2. Electrical components introduction

1) Power protector

This module is used to detect power supply and provide protection in case of phase loss, phase sequence, and under voltage of incoming line power, so as to prevent damage to the compressor or other components caused by power failure. Some models also provide protection for overvoltage and three phase imbalance.



2) Time Relay and Intermediate Relay

The time relay is an automatic switch device which performs delayed control based the electromagnetic or mechanical principles. It controls the star delta switching time for the compressor contactor. The preset time is star operation time (6s). The coil voltage is AC 220V. The rated contact current is usually low and is used for controlling the loop only.

The intermediate relay delivers intermediate signals among control circuits to increase the number and capacity of contacts. Normally, the main control board output controls starting and stopping of loads such as motor and water pump by using the intermediate relay to drive the contactor coil. The coil power supply can be DC or AC. Our standard screw compressor model uses the AC220V coil.

3) Compressor thermal overload relay

The thermal overload relay works based on the principle of heating effect of electric current. With inverse time limit action feature which is similar to the permissible overload feature of the motor, it is used to provide overcurrent protection for the compressor and fan. For compressor overload protection, the major loop current of the motor is converted to an AC 0-5 A current signal by the current mutual inductor. Then the thermal overload relay performs overload protection. For fan overload protection, the thermal overload relay is connected in series with the major loop.

4) Current transformer and Transducer

The current transformer transforms primary current with a larger value to secondary current with a smaller value for the purpose of protection or measurement. A current transformer with transformation ratio of 400/5 can transform 400A current to 5A.

A transducer transduces the measured current to DC voltage or DC current. After the current transformer transforms the current to AC 0-5 A current signals, the transducer outputs 4-20 mA analog signal based on the linear scale to the main control board.



5) Electronic Expansion Valve

The electronic expansion valve is equipped with a stepping motor which controls the valve status. A special-purpose electronic expansion valve control module is required to drive the electronic expansion valve.



1) Solenoid Valve

When the solenoid valve is energized, the electromagnetic coil generates electromagnetic force to pull up the closed component from the valve seat and the valve is open. When the solenoid valve is powered off, the spring pushes the closed component to the valve seat once the electromagnetic force disappears and the valve is closed. Voltage of the solenoid valve washer is AC220V, and it is driven directly by the main control board output.

3. Electrical parts parameter setting

1) Power protector

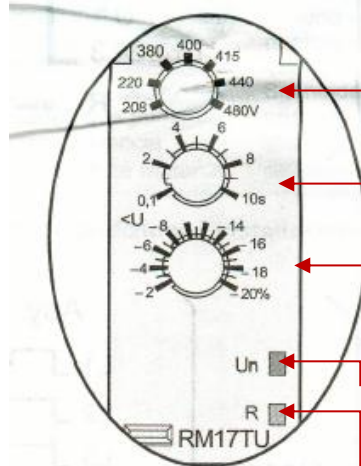

U: 380V

T: 6S

< U :

Power LED , on lighting

running LED
normal lighting;
fault off

Power protector use Schneider RM17TU type.

- ① Select the voltage class. For standard units, the voltage is 380 V.
- ① Set the delay to 6s.
- ② Set the under voltage value to 10%.

Note: Set the processing parameters only when the system is powered off.

2) Time Relay

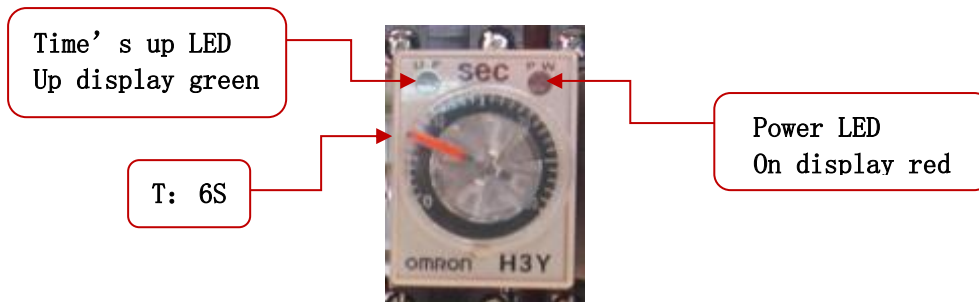

Time relay use Omron H3Y type.

3) Compressor and fan thermal overload relay

Thermal overload relay takes advantage of heating effect to protect the compressor and fans.

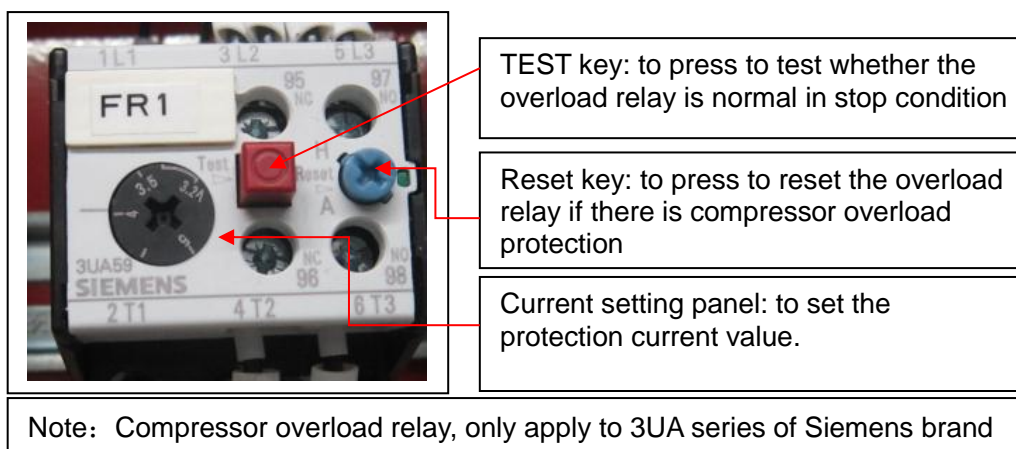

Compressor thermal relay value:

The calculation of compressor overload value (transformation ratio of current mutual inductor is A/B) is as follows:

$$(\text{Maximum running current of compressor}/\text{current mutual inductor A}) \times B = \text{Thermal relay value of compressor}$$

For example, if the maximum running current of compressor is 250 A, and the transformation ratio of current mutual inductor is 300/5, Thermal relay value = $(250/300) \times 5 = 4.17$

Note: Use a value that is smaller than the calculated one. For example, in the preceding calculation, the calculated value is 4.17; in practice, set the value to 4.15.

Unit Type	Maximum Running Current of Compressor	Transformation Ratio of Current Transformer	Thermal Relay Value of Compressor
340	139.6	250/5	2.8
440	174.1	250/5	3.5
540	203.5	300/5	3.4
690	277.5	400/5	3.4
805	342.7	500/5	3.4
890	370.8	500/5	3.7
1080	203.5x2	300/5	3.4
1200	224.6x2	300/5	3.7
1385	277.5x2	400/5	3.4
1620	342.7x2	500/5	3.4

1780	370.8x2	500/5	3.7
------	---------	-------	-----

4. Field wiring

1) Wiring diagram

Power supply wiring diagram

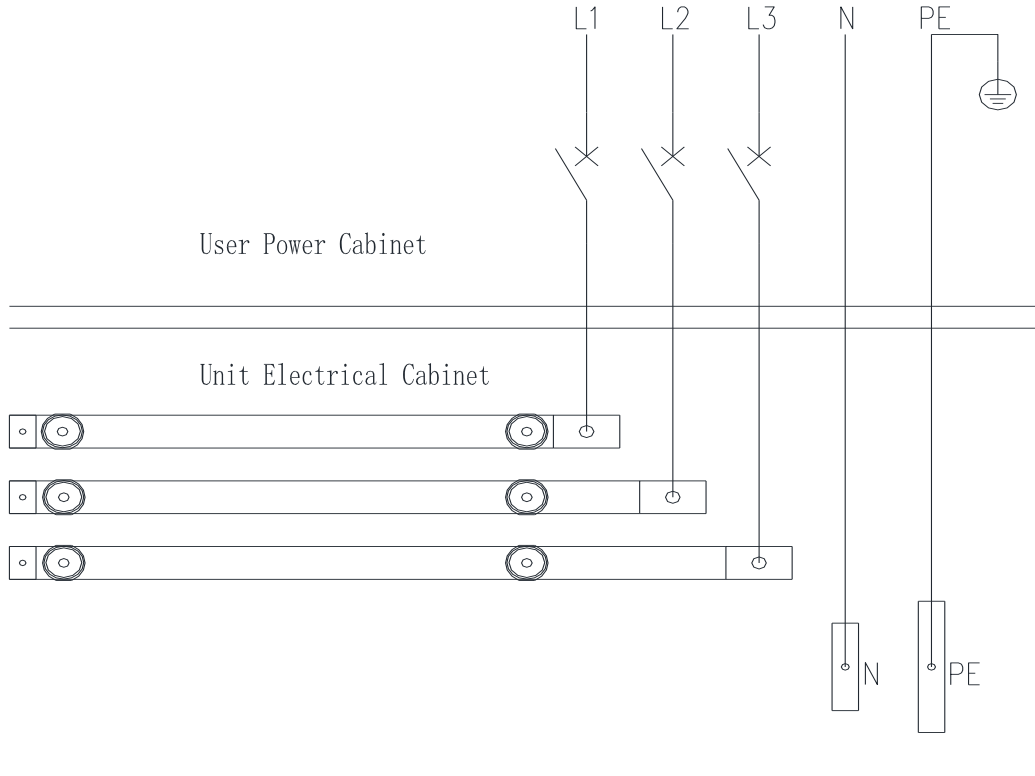

Water Pump Wiring Diagram

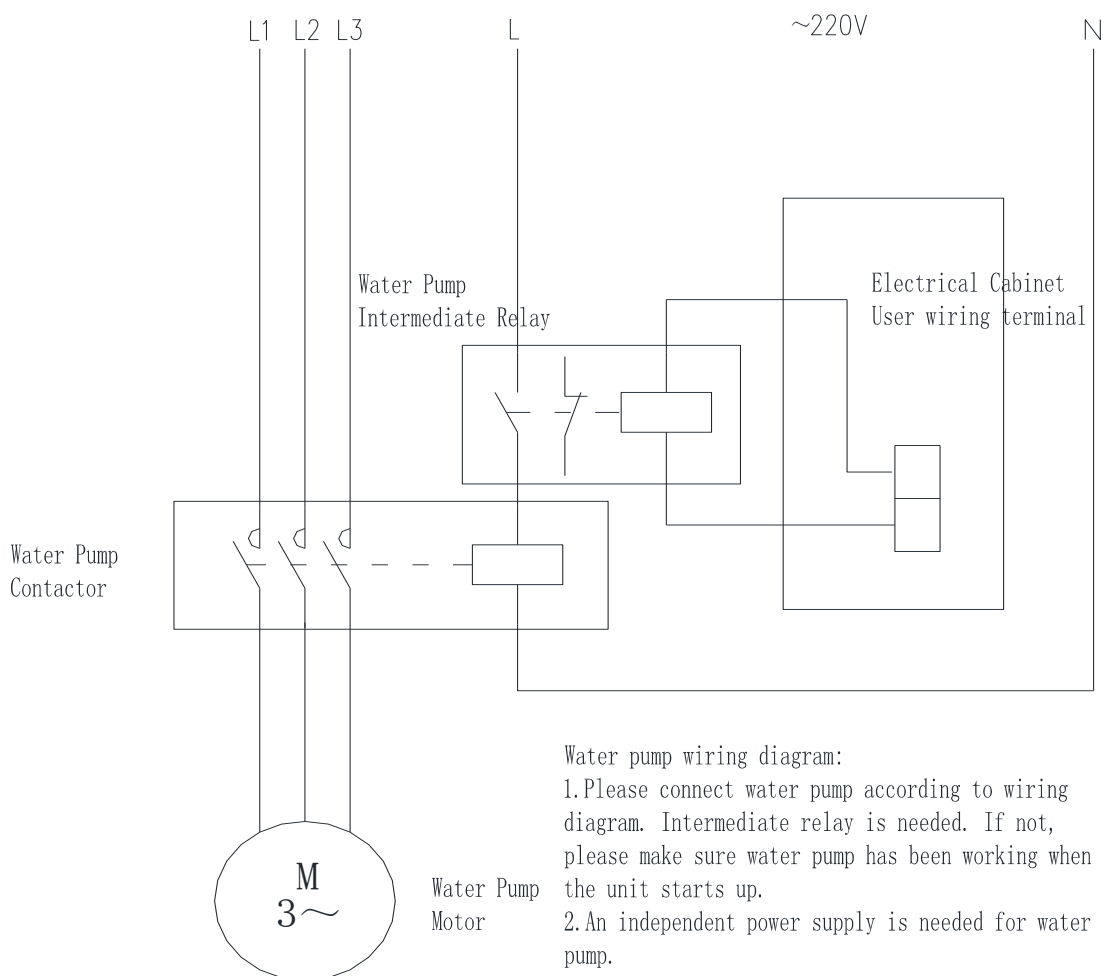

Water pump wiring diagram:

1. Please connect water pump according to wiring diagram. Intermediate relay is needed. If not, please make sure water pump has been working when the unit starts up.
2. An independent power supply is needed for water pump.
3. It is forbidden to drawn power wire from unit electrical cabinet. Midea has no liability for electrical accident caused by this.

Recommended external wiring cable

Unit Model	External wiring cable (mm2)	Unit Model	External wiring cable (mm2)
MWSC340A-FB3	4×AWG1+AWG3	MWSC1080A-FB3	4×AWG400+AWG4/0
MWSC440A-FB3	4×AWG1/0+AWG3	MWSC1200A-FB3	4×AWG500+AWG250
MWSC540A-FB3	4×AWG3/0+AWG1	MWSC1385A-FB3	4×AWG600+AWG300
MWSC690A-FB3	4×AWG4/0+AWG1/0	MWSC1620A-FB3	4×(2×AWG300)+AWG300
MWSC805A-FB3	4×AWG300+AWG4/0	MWSC1780A-FB3	4×(2×AWG400)+AWG500
MWSC890A-FB3	4×AWG400+AWG4/0		

Notice: The given wire length limits the voltage drop to < 2%. If the length can not be reduced, the power cord should be bolder.

If the cable is installed in pipe or the ambient temperature is above 40°C, it's necessary to enlarge the wire section. Please refer to relevant electrical code for selection according to the max. running current.

2) Remote control wiring

The wiring ports for remote start/stop, flow switch, water pump linked control, alarm indication, etc. are reserved in the electrical cabinet of the unit, with the numbers shown in the diagram below.

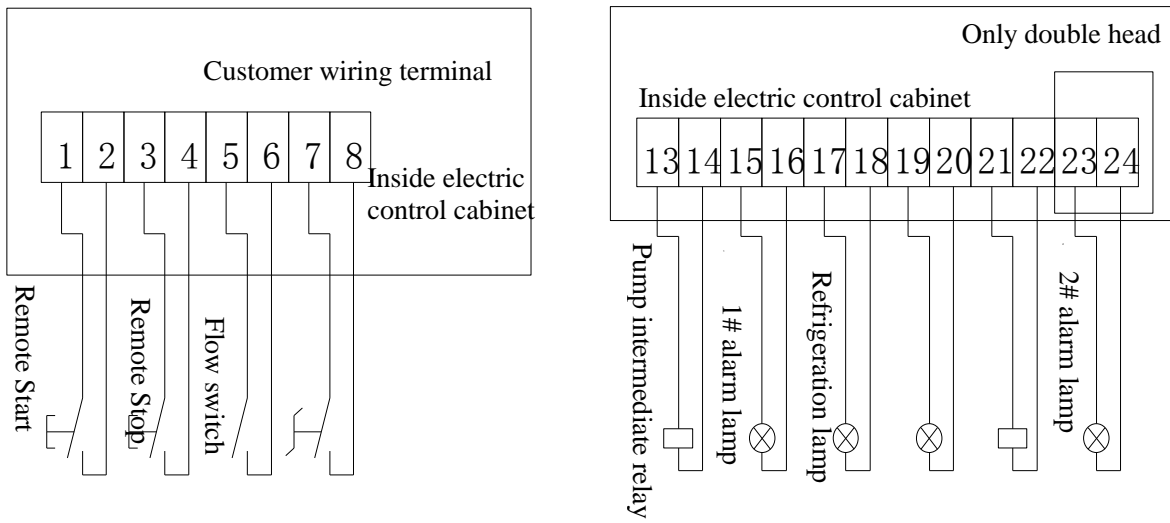

Remote start/stop switch need to use inching switch.

Lamp input 220VAC.

5. Wiring Diagrams

MWSC340~890A-FB3

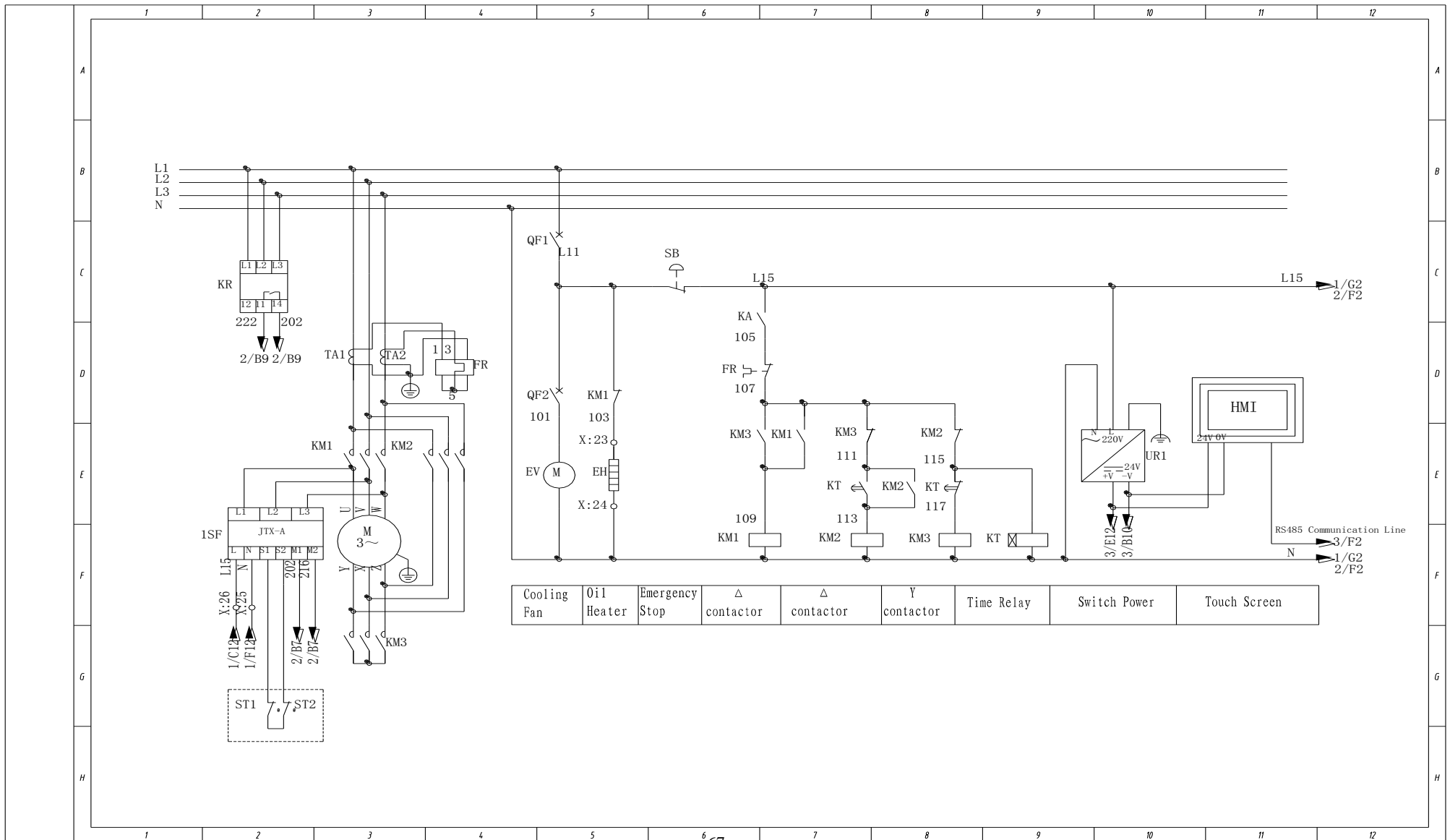

Flooded type water cooled screw chiller (PCB Control)

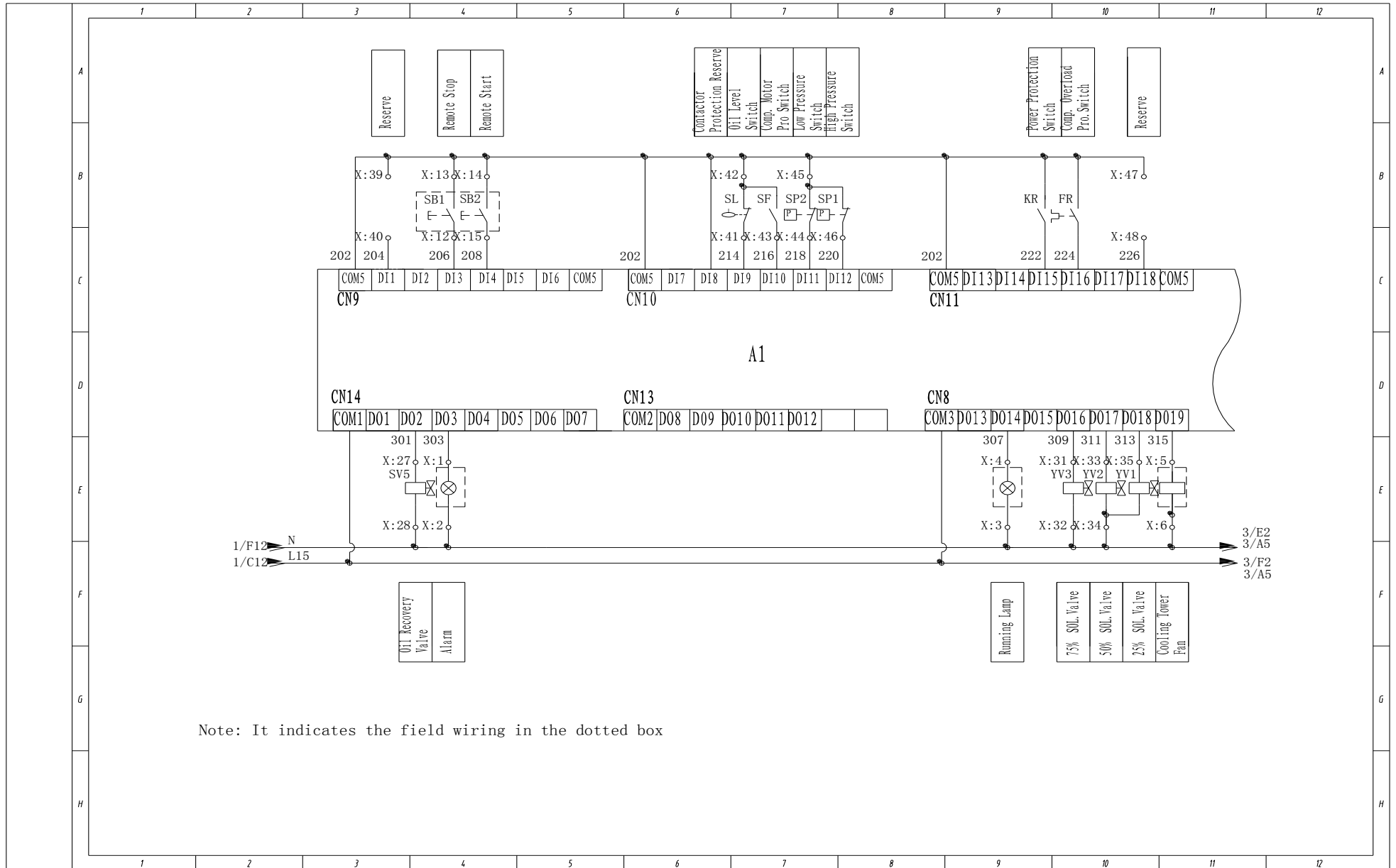

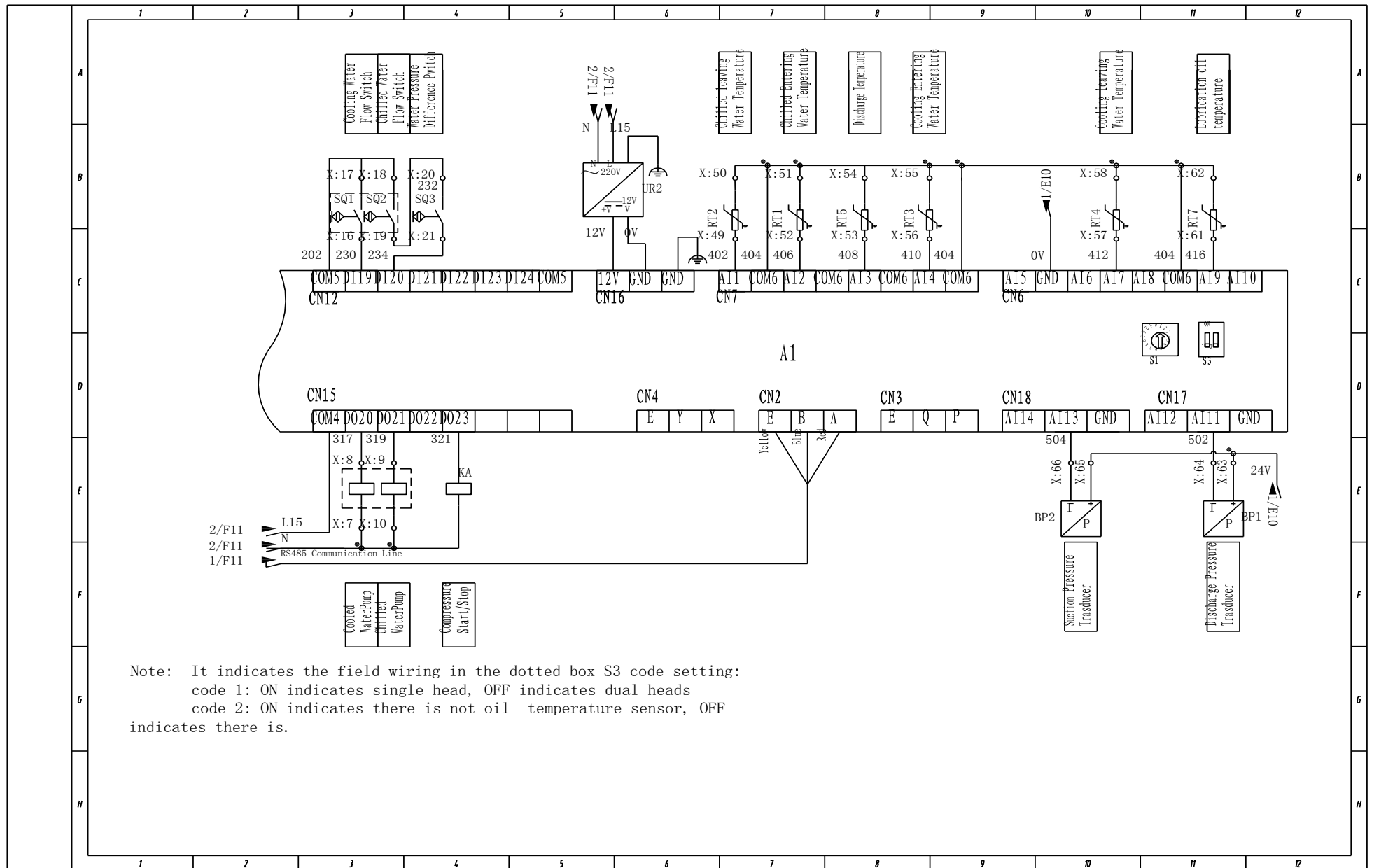

Flooded type water cooled screw chiller (PCB Control)

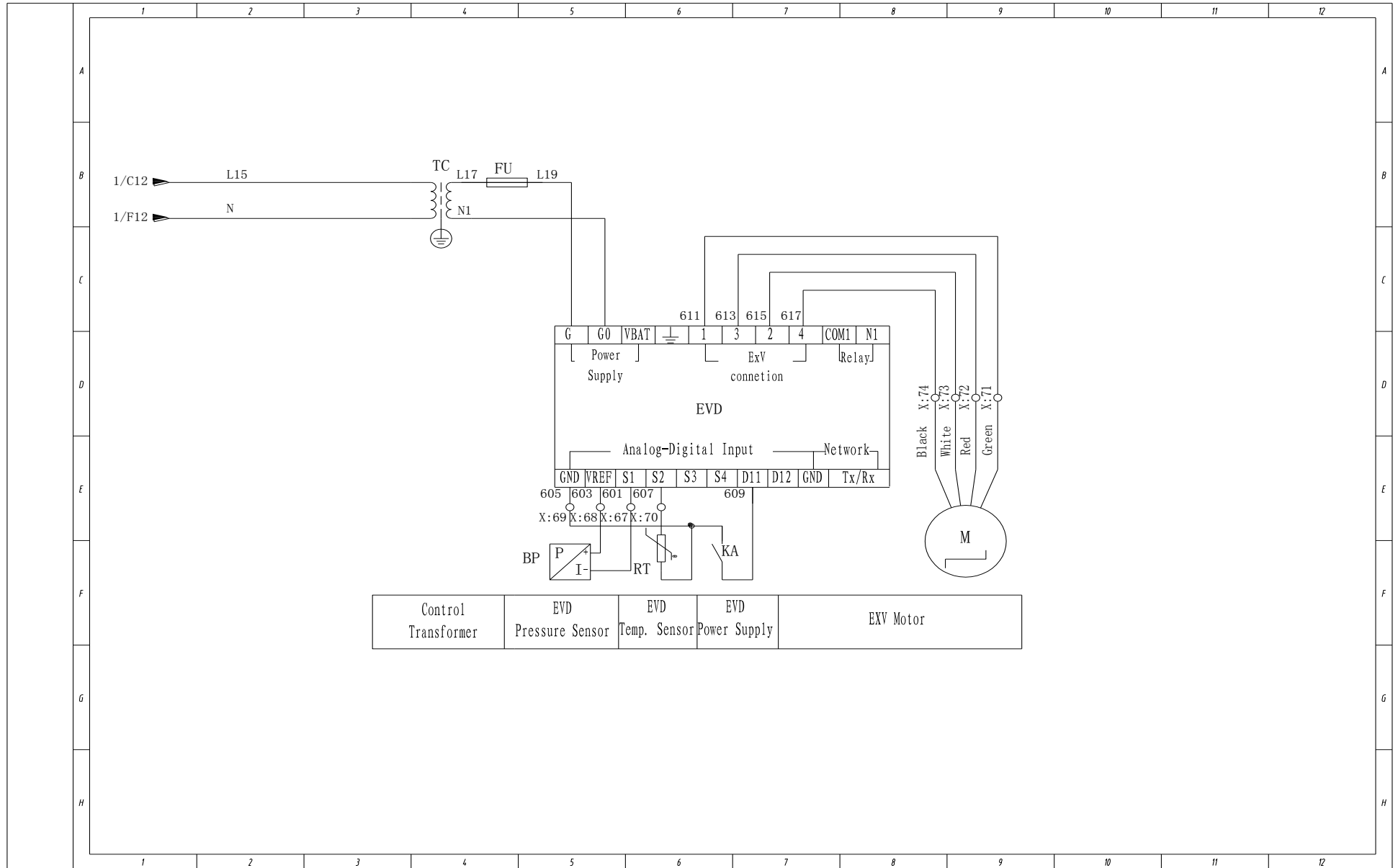

MWSC1080~1780A-FB3

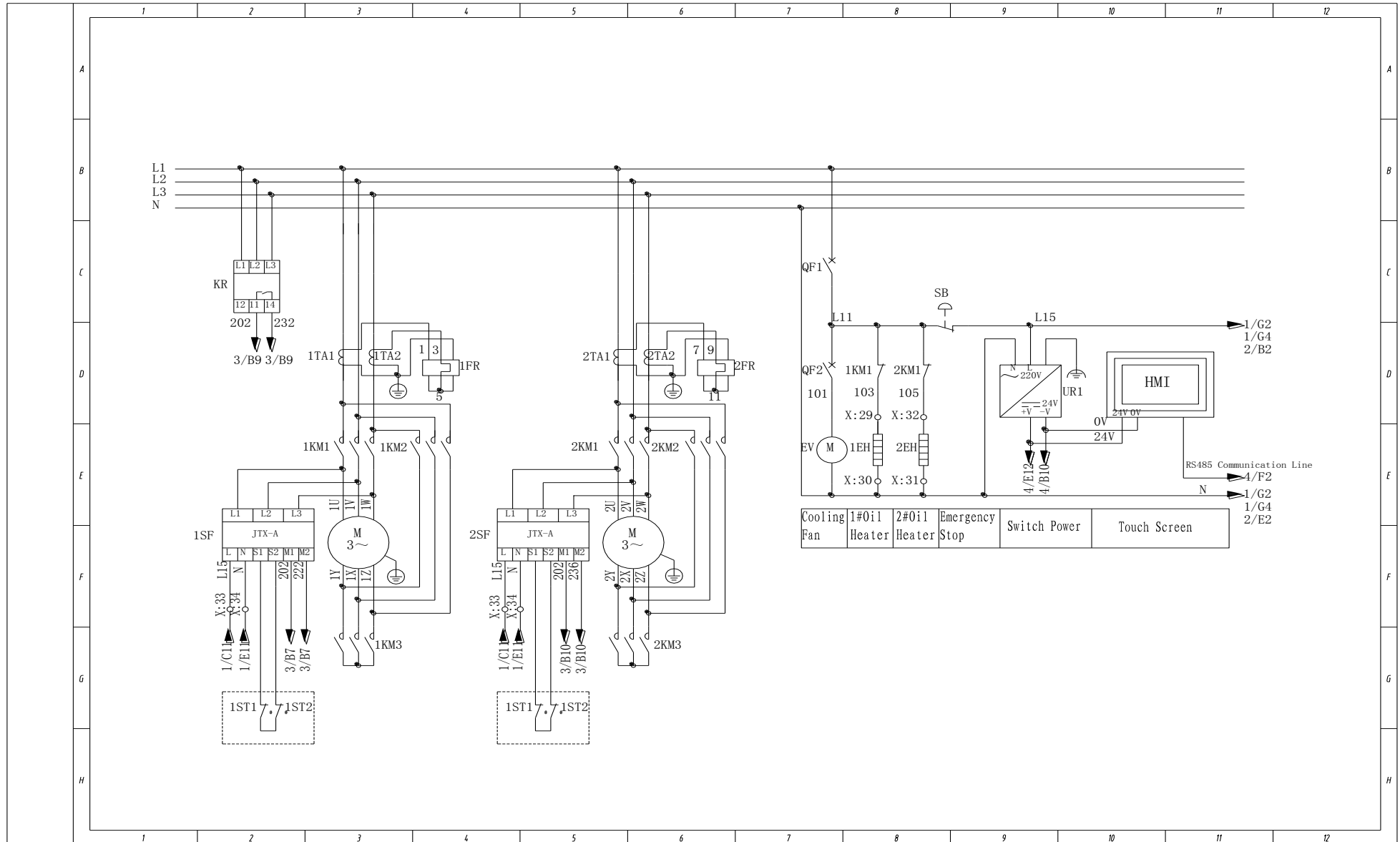

Flooded type water cooled screw chiller (PCB Control)

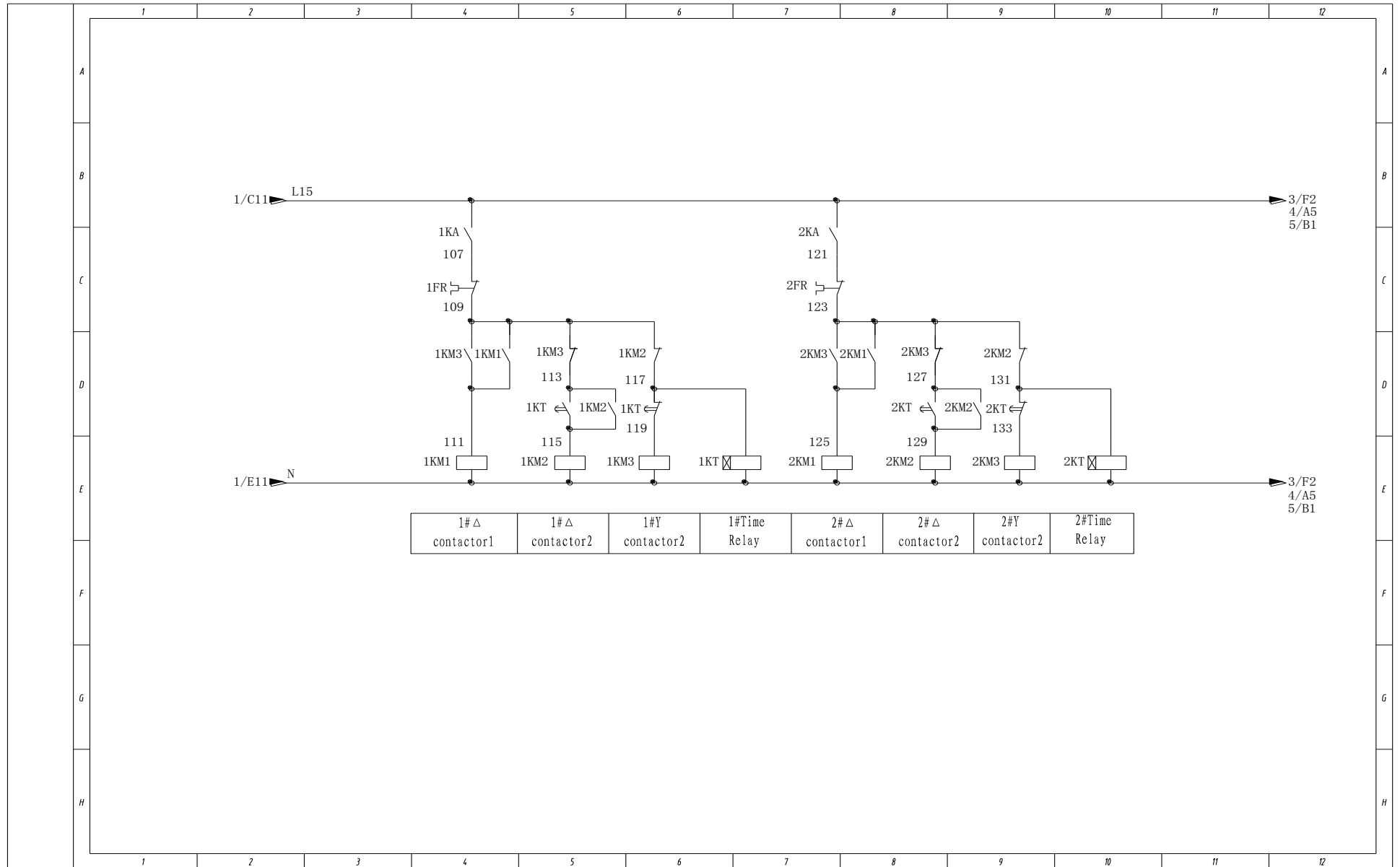

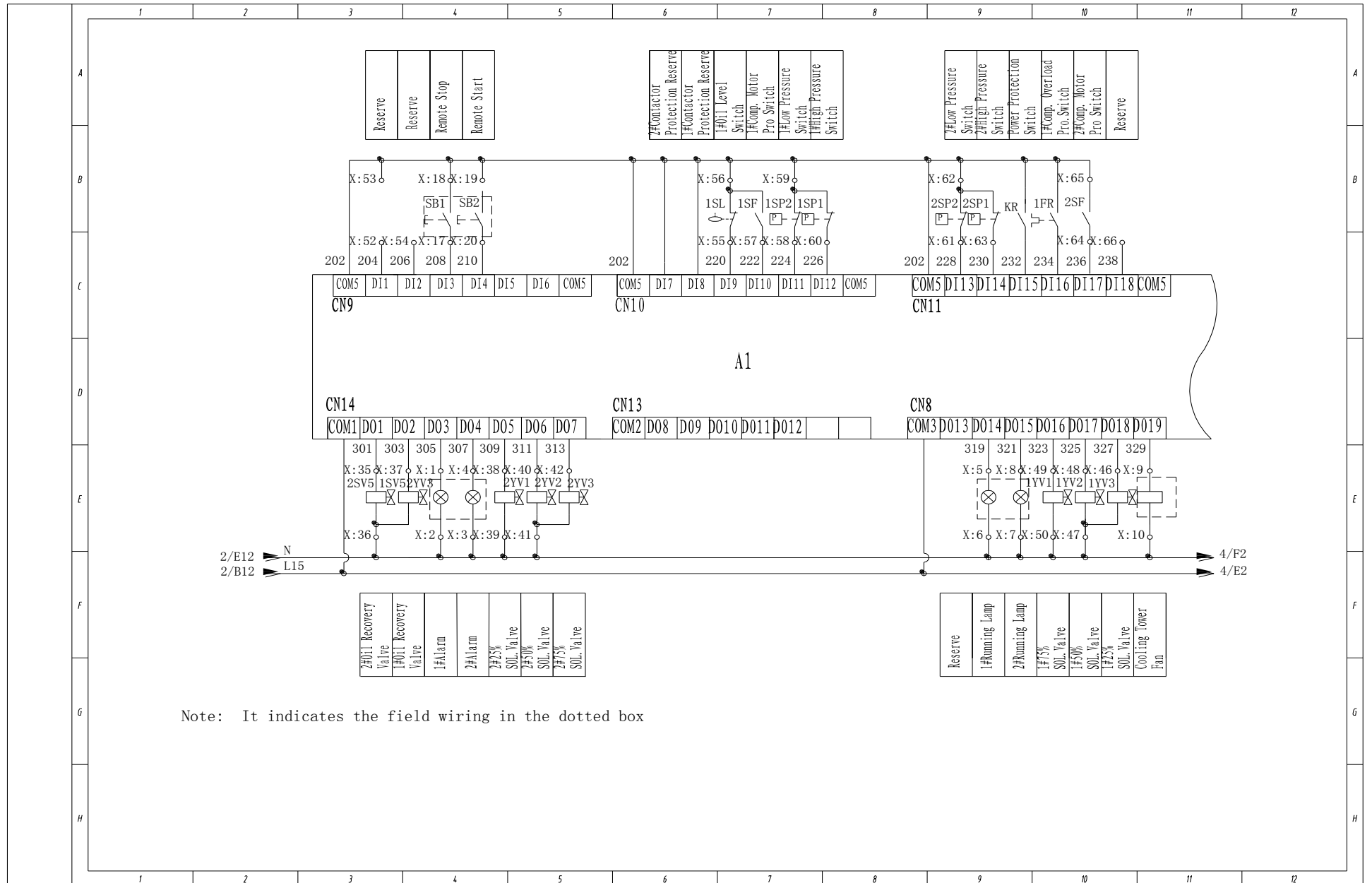

Flooded type water cooled screw chiller (PCB Control)

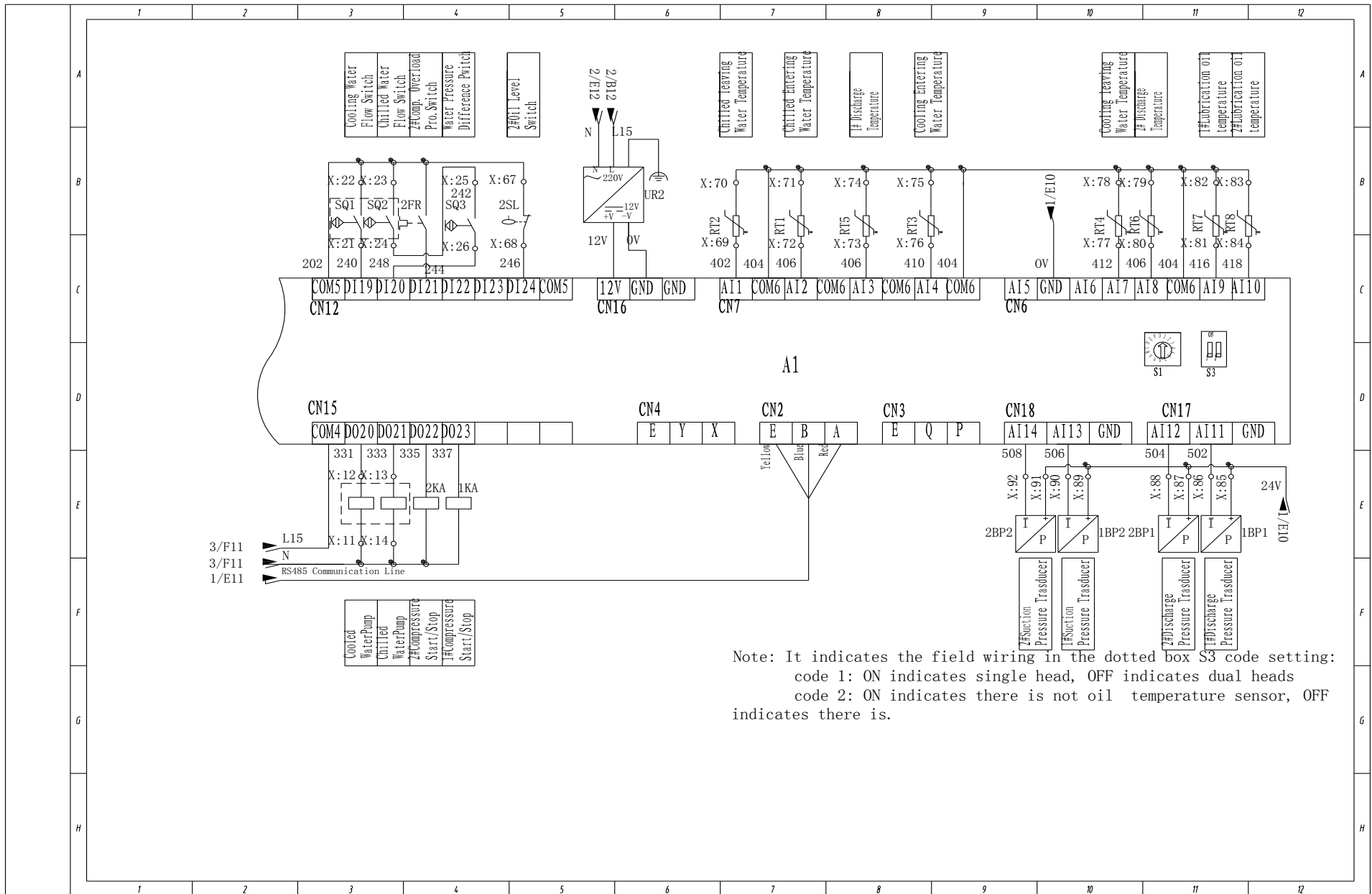

Note: It indicates the field wiring in the dotted box S3 code setting:
 code 1: ON indicates single head, OFF indicates dual heads
 code 2: ON indicates there is not oil temperature sensor, OFF indicates there is.

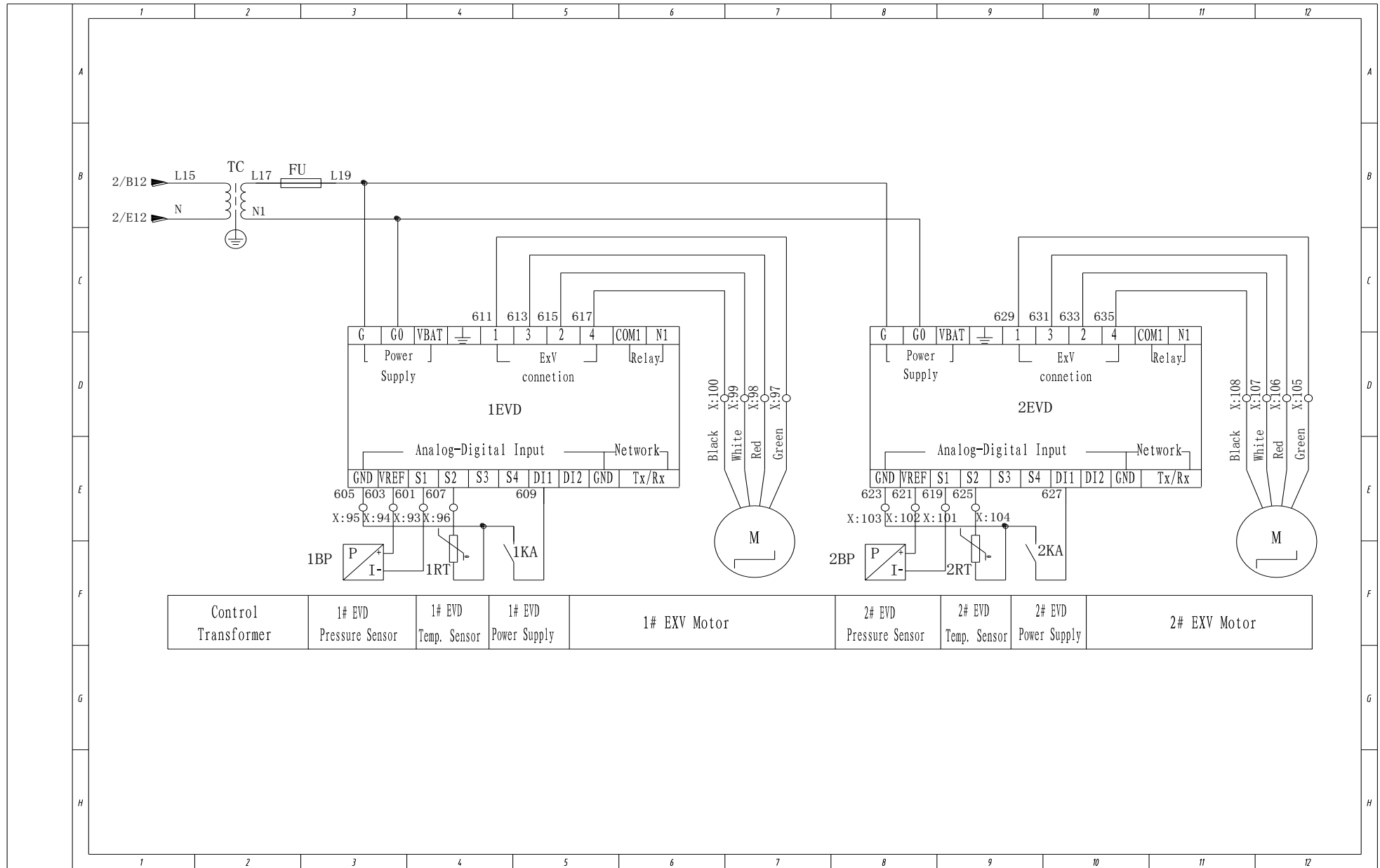

V. Installation

Safety considerations

Access to the unit must be reserved to authorized personnel, qualified and trained in monitoring and maintenance. The access limitation device must be installed by the customer.

After the unit has been received, when it is ready to be installed or reinstalled, and before it is started up, it must be inspected for damage. Check that the refrigerant circuit(s) is (are) intact, especially that no components or pipes have shifted. If in doubt, carry out a leak tightness check and verify with the manufacturer that the circuit integrity has not been impaired. If damage is detected upon receipt, immediately file a claim with the shipping company.

Strongly recommend employing a specialized company to unload the machine.

Safety is only guaranteed, if these instructions are carefully followed. If this is not the case, there is a risk of material deterioration and injuries to personnel.

1. Unit installation

1).Lifting

- ① When transporting the unit, please make sure there is no any collision happens between the unit and other objects.
- ② Move the unit by placing a roller in the bottom of the unit to avoid damage.
- ③ Choose a suitable crane according to the unit's weight (Buy an insurance for it if it is convenient) ; Hoist the unit according to the following chart strictly. The steel rope shall wind the lifting hook one circle to prevent steel rope slipping and causing danger when the weight is unbalanced. Security guard circle should be set up when hoist the unit, and also abide by the local Safety Regulations when hoist the unit. Prohibit non-staff entering the job site or staying under the unit or the hoisting crane.

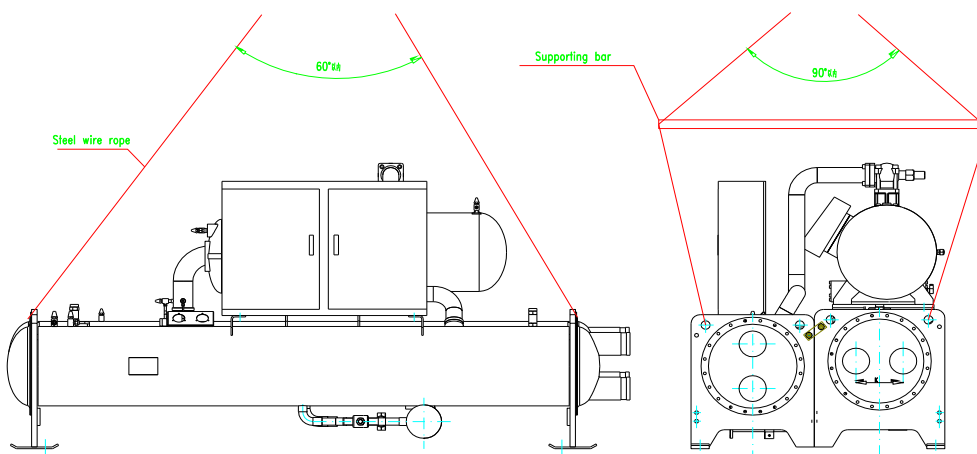

Any person is not allowed to stand below the unit when sling it.

2) Foundation

- ① Please take into account the construction of installation foundation. Attention should be especially paid to the intensity of the floor and noise elimination when installing the unit in interlayer or on the top floor. It is suggested to consult the building designer before installation.
- ② For convenient drainage, gutter way should be made around the basement to ensure the drainage unblocked.
- ③ To eliminate the vibration and noise, put an absorber between the unit and basement and keep the unit in balance. Install a shockproof foundation when necessary.
- ④ Vibration isolators are recommended for all roof mounted installations or wherever vibration transmission is a consideration. Neoprene Isolation is optional, it is recommended for normal installations and provides good performance in most applications for the least cost. Spring isolator is level adjustable, spring and cage type isolators for mounting under the unit base rails. 1" nominal deflection may vary slightly by application.

Typical Isolation:

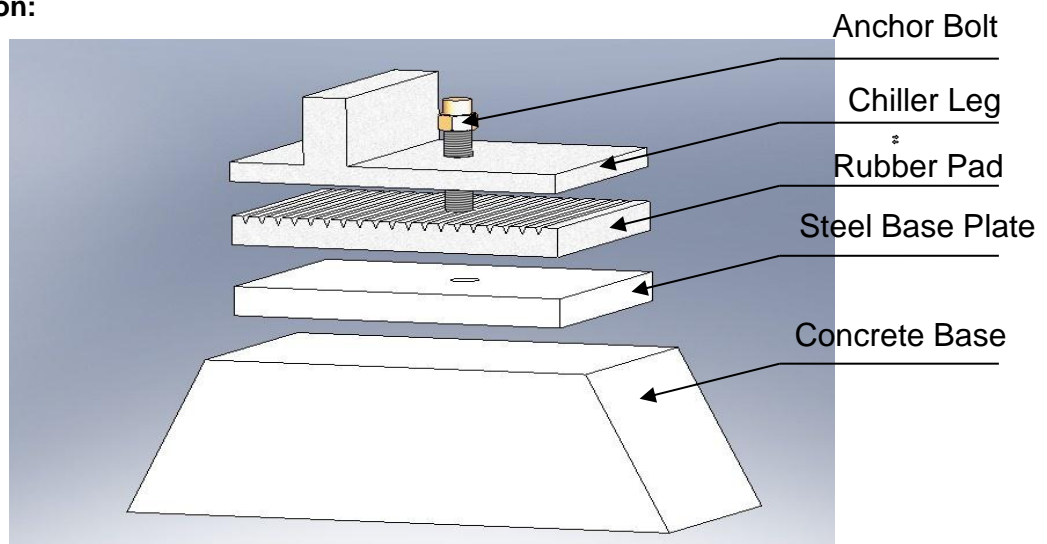

Foundation Dimensions

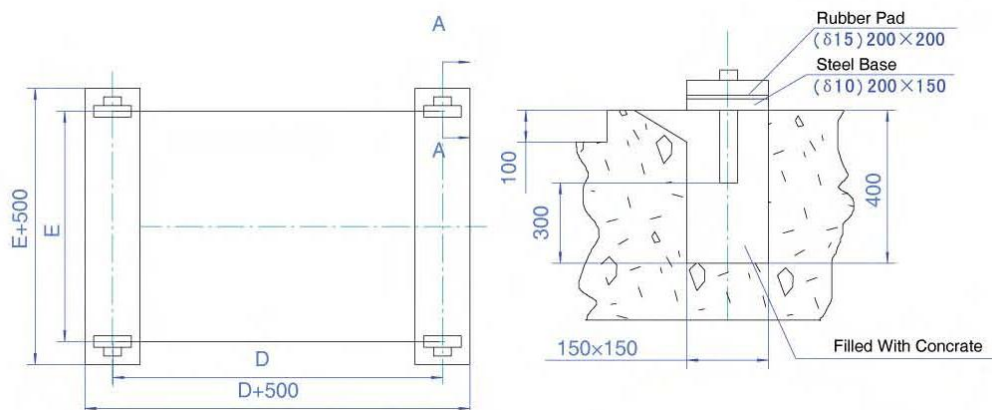

Foundation Bolt Installation Dimension Table

Model Dimension	MWSC***A-FB3										
	340	440	540	690	805	890	1080	1200	1385	1620	1780
D(mm)	2850	2850	2850	2850	2850	2850	3850	3850	3850	3850	3850
E(mm)	1100	1100	1100	1300	1300	1300	1400	1400	1400	1500	1500

3) Vibration isolators

Put the absorbers under unit saddles before final positioned the unit. The quantity of absorber used for each unit is always decided by the elasticity or durometer value of the absorber. Below please refer to the typical isolation pad and vibration isolator for selection.

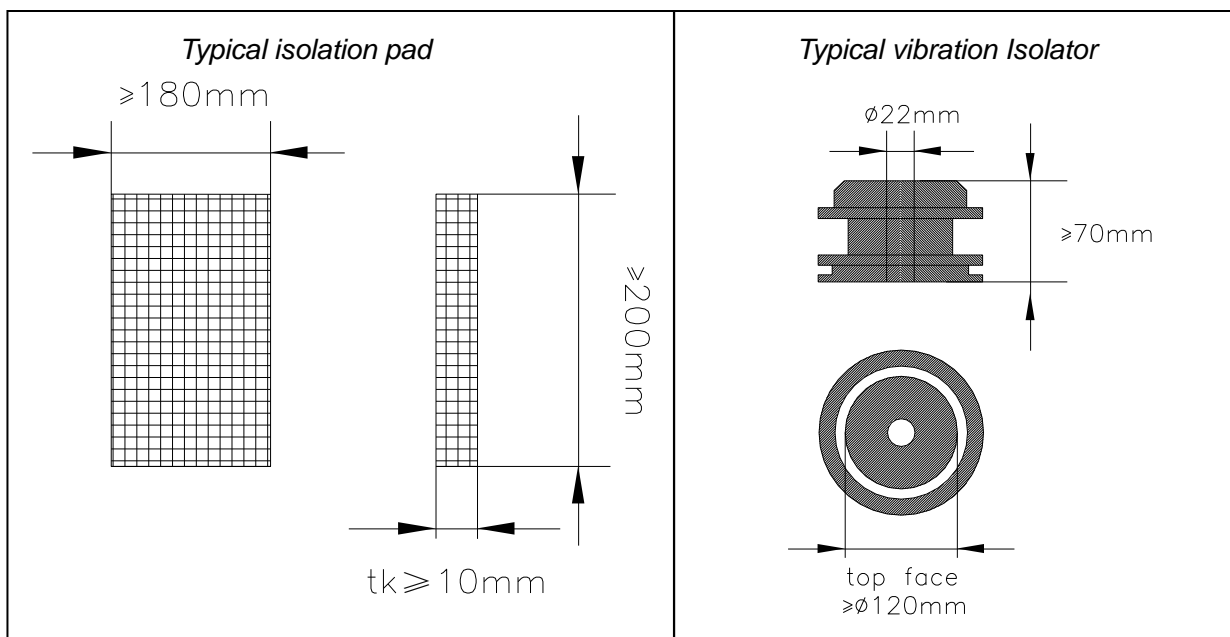

Expected load bearing value listed below:

Model	Isolation pad		Vibration Isolator		Running weight(kg)
	Minimum load bearing (kg/EA)	Minimum Quantity	Minimum load bearing (kg/EA)	Quantity	
MWSC340A-FB3	900	4	900	4	2700
MWSC440A-FB3	1000	4	1000	4	2820
MWSC540A-FB3	1200	4	1200	4	3220
MWSC690A-FB3	1400	4	1400	4	3870
MWSC805A-FB3	1800	4	1800	4	4420
MWSC890A-FB3	1800	4	1800	4	4550
MWSC1080A-FB3	2000	4	2000	4	7250
MWSC1200A-FB3	2200	4	2200	4	7490
MWSC1385A-FB3	2200	4	2200	4	7820
MWSC1620A-FB3	2200	4	2200	4	9200
MWSC1780A-FB3	2200	4	2200	4	9350

Note:

- (1) Pads have to extend the full length of the saddle when isolation pad be used.
- (2) Level the unit to within 5mm over through it's length and width after absorbers installed.

4).Spaces

- ① Leave enough space above and around unit for operation and maintenance. For cleaning the copper pipes or exchanging pipes, there should be enough space reserved(for single compressor unit, it should be at least 3.5m, for dual compressor unit, it should be 5m), and the other end of the unit should have at least 2.0m space, use the hole on door or other holes with appropriate position; there should have the space of 0.7m in front of the unit (the side faces to the electric cabinet) for operation; the space in front and back of the unit should not less than 0.6m .
- ② Do not install the unit at the place exposed to sunlight or other heat sources.
- ③ Near the power supply where it is convenient for wiring.
- ④ The floor is solid enough and the location should not easily bring about resonance or noise.
- ⑤ Put the unit indoors which should be well-ventilated with low humidity and little dust.

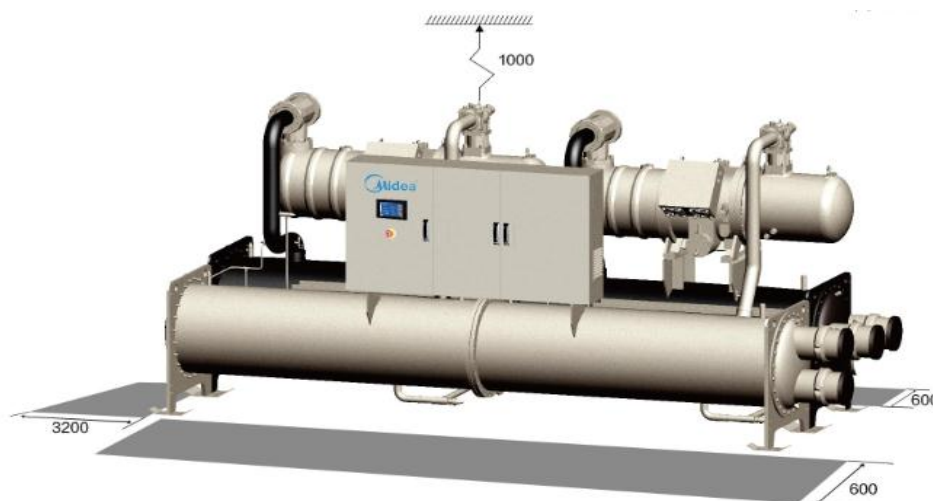

2. Water pipeline system installation

1) Water quality control

When industrial water is used as chilled water, little furring may occur; however, well water or river water, used as chilled water, may cause much sediment, such as furring, sand, and so on. Therefore, well water or river water must be filtered and softened in softening water equipment before flowing into chilled water system. If sand and clay settle in the evaporator, circulation of chilled water may be blocked, and thus leading to freezing accidents; if hardness of chilled water is too high, furring may occur easily, and the devices may be corroded. Therefore, the quality of chilled water should be analyzed before being used, such as PH value, conductivity, concentration of chloride ion, concentration of sulfide ion, and so on.

※ Applicable standard of water quality for the unit

PH value	Total hardness	Conductivity	Sulfide ion	Chloride ion	Ammonia ion	Sulfate ion	Silicon	Iron content	Sodium ion	Calcium ion
7~8.5	<50ppm	<20μV/cm(25°C)	No	<50ppm	No	<50ppm	<30ppm	<0.3ppm	No requirement	<50ppm

2). Performance adjustment factors

Ethylene and Propylene Glycol Factors

A glycol solution is required when the unit with condition as mentioned. The use of glycol will reduce the performance of the unit depending on concentration.

Ethylene Glycol

	Evaporator side					
	Quality of glycol (%)	Cooling capacity modification	Power modification	Water flow modification	Water resistance	Freezing point °C
Ethylene glycol	30	0.972	0.99	1.013	1.215	-16
	35	0.971	0.984	1.04	1.267	
	40	0.965	0.977	1.074	1.325	-23
	45	0.96	0.967	1.121	1.389	
	50	0.946	0.955	1.178	1.458	-35
	Condenser side					
	30	0.991	1.02	1.013	1.164	-16
	35	0.989	1.027	1.04	1.212	
	40	0.986	1.032	1.074	1.261	-23
	45	0.984	1.037	1.121	1.309	
50	0.98	1.044	1.178	1.362	-35	

Note: the freezing point not shown here, please calculate according to interpolation method.

Propylene Glycol

	Evaporator side					
	Quality of glycol (%)	Cooling capacity modification	Power modification	Water flow modification	Water resistance	Freezing point °C
Propylene glycol	30	0.968	0.969	1.01	1.16	-13
	35	0.964	0.955	1.028	1.287	
	40	0.955	0.937	1.05	1.4	-21
	45	0.945	0.914	1.078	1.502	
	50	0.929	0.89	1.116	1.604	-33
	Condenser side					
	30	0.969	1.023	1.01	1.227	-13
	35	0.959	1.029	1.028	1.276	
	40	0.944	1.039	1.05	1.329	-21
	45	0.923	1.054	1.078	1.388	
50	0.896	1.078	1.116	1.453	-33	

Note: the freezing point not shown here, please calculate according to interpolation method.

Units operating with glycol solutions are not included in the ARI Certification Program.

Altitude correction factors

Performance tables are based at sea level. Elevations other than sea level affect the performance of the unit. The decreased air density will reduce condenser capacity and reduce the unit's performance. For performance at elevations other than sea level refer to below table Maximum allowable altitude is 1800 meters.

Evaporator temperature drop factors

Performance tables are based on a 5°C temperature drop through the evaporator. Adjustment factors for applications with temperature ranges from 3°C to 6°C in follow table. Temperature drops outside this range can affect the control system’s capability to maintain acceptable control and are not recommended.

Fouling Factor

ALTITUDE (m)	Fouling Factor							
	0.018m ² °C /kW		0.044m ² °C /kW		0.086m ² °C /kW		0.172m ² °C /kW	
	C	P	C	P	C	P	C	P
Sea level	1.042	1.028	1.029	1.020	1.000	1.000	0.977	0.995
600	1.027	1.037	1.014	1.029	0.986	1.009	0.964	1.004
1200	1.014	1.050	1.001	1.041	0.973	1.021	0.951	1.016
1800	1.000	1.060	0.987	1.052	0.960	1.031	0.938	1.026

C--Cooling capacity

P—Power

3).Design of the store tank in the system

a. kW is the unit for cooling capacity, L is the unit for (G) minimum water flow volume in the formula.

Comfortable type air conditioner

G= cooling capacity×2.6L

Process type cooling

G= cooling capacity×7.4L

b. In certain occasion (especially in manufacture cooling process), for conforming the system water content requirement, it’s necessary to mount a tank equipping with a cut-off baffle at the system to avoid water short-circuit, Please see the following schemes:

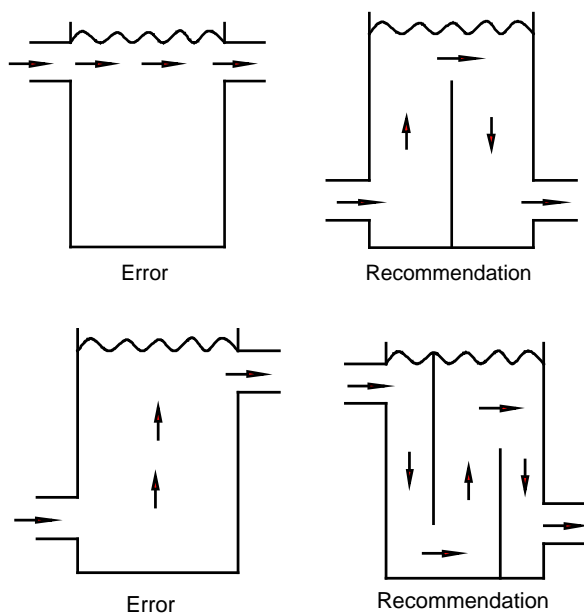

4).Water pipeline installation

Due to the variety of piping practices, it is advisable to follow the recommendations of local authorities. The installation and insulation of the water pipelines of the air conditioning system shall be designed and

guided by design professionals, and confirm to the corresponding provisions of the HVAC installation specifications.

Basically, the piping should be designed with a minimum number of bends and changes in elevation to keep system cost down and performance up.

1) Condenser, cooling water piping suggested piping as follow:

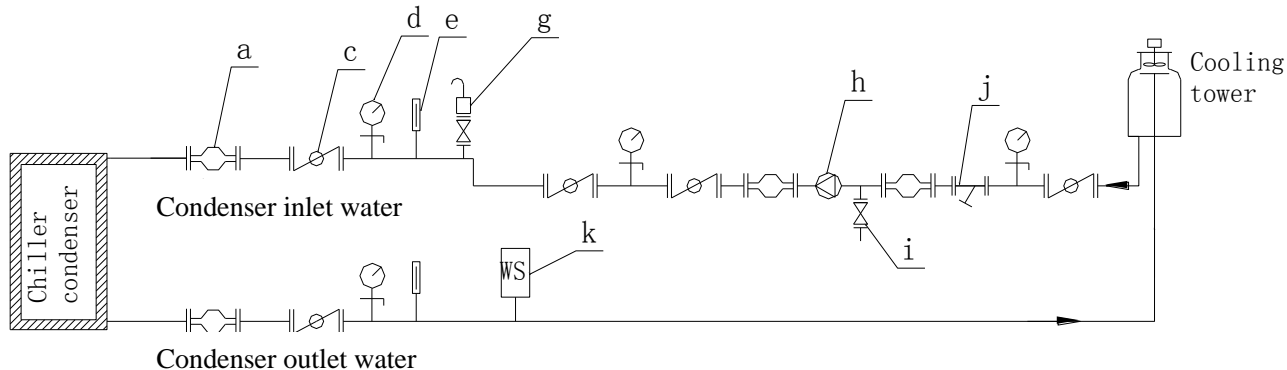

(Condenser, cooling water hose connection diagrammatic sketch)

a Shockproof joint	k Flow switch
c Butterfly valve	d Pressure gauge
e Thermometer	f Platinum resistance thermometer
g Air vent	h Water pump
l Drain valve	j Y- shape strainer

Note: All of water pipe accessories and flow switch is provide by user.

2) Chilled water piping suggested piping as follow:

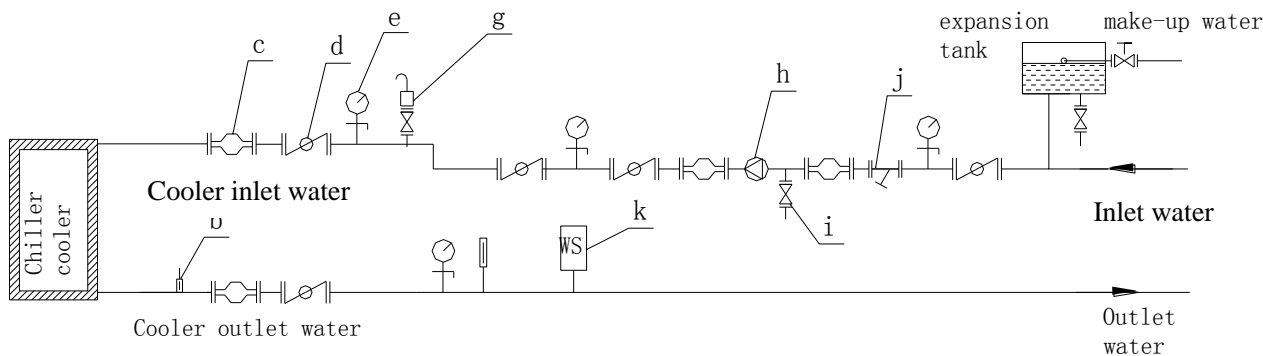

(Chiller cooler piping diagrammatic sketch)

c Flex connection	b Pressure type temperature controller
e Pressure gauge	d Butterfly valve
g Air vent	h Water pump
i Drain valve	j Y- shape strainer
k Flow switch	

Note: All of water pipe accessories and flow switch is provide by user.

User must install flow switch in the outlet pipe of cooler and evaporator, it's two sides must be level straight pipe which length longer than five times of pipe diameter.

3) The water inlet pipeline and drain pipeline shall be connected according to the requirements of markings on the unit. Generally, the refrigerant pipe side of the evaporator is the chilled water

outlet side.

- 4) The chilled water pipeline system must be provided with the soft connection, thermometer, pressure gauge, water filter, electronic scale remover, check valve, target flow controller, discharge valve, drain valve, stop valve, expansion tank, etc.
- 3) The water system must be fitted with the water pump with appropriate displacement and head, so as to ensure normal water supply to the unit. The soft connection shall be used between the water pump, unit and water system pipelines, and the bracket shall be provided to avoid stress on the unit. Welding work for installation shall avoid damage to the unit.

(1) Determination of water pump flow:

$$\text{Flow (m}^3\text{/h)} = (1.1 \sim 1.2) * \text{Unit Cooling Capacity (kW)}/5.8$$

(2) Determination of water pump head:

$$\text{Head (m)} = (\text{Unit Resistance (see product parameters)} + \text{Resistance at Maximum End of Pressure Drop (see product parameters)} + \text{Pipeline Resistance (length of the least favorable loop pipe} * 0.05) + \text{Local Resistance (length of the least favorable loop pipe} * 0.05 * 0.5)) * (1.1 \sim 1.2)$$

- 4) The flow switch must be arranged on the drain pipe of the evaporator. The flow switch shall be interlocked with the input contact in the control cabinet. Its installation requirements are as follows:

- (1) The flow switch shall be installed on the pipe vertically.
- (2) The straight pipe section at each side of the flow switch shall have a length that is at least 5 times the pipe diameter; do not install it near the elbow, orifice plate or valve.

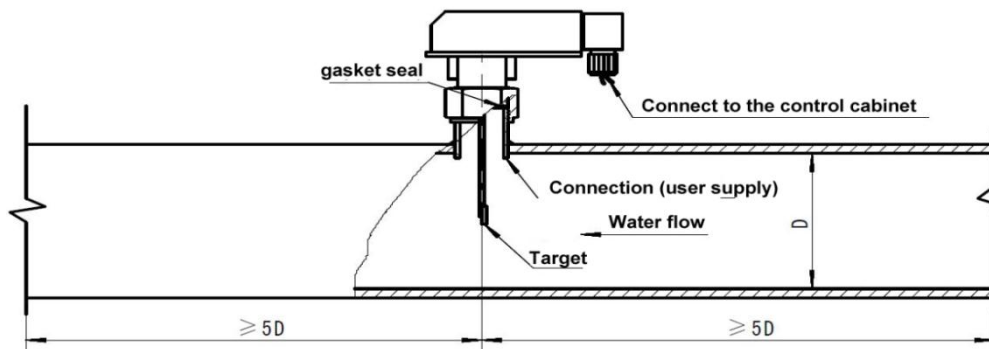

- (3) The direction of the arrow on the flow switch must be consistent with the direction of water flow.
- (4) In order to prevent vibration of the flow switch, remove all air in the water system.
- (5) Adjust the flow switch to keep it in open state when the flow is lower than the minimum flow (the minimum flow is 70% of the design flow). When the water flow is satisfied, the flow switch shall keep in closed state.
- 5) The water filter must be installed before the water inlet pipeline of the unit, which shall be provided with a 25-mesh screen. This will aid in preventing foreign material from entering and

decreasing the performance of the evaporator.

- 6) A strainer should be placed for enough upstream to prevent cavitation at the pump inlet (consult pump manufacturer for recommendations). The use of a strainer will prolong pump life and help maintain high system performance levels
- 7) The flushing and insulation of the water pipelines shall be carried out before it is connected with the unit, so as to prevent dirt from damaging the unit.
- 8) The design water pressure of the water chamber is 1.0Mpa. Use of the water chamber shall be not exceeding this pressure in order to avoid damaging the evaporator.
- 9) Do not load the weight of water pipe onto the unit. When water inlet/outlet are connected with corresponding water pipe, soft connection such as rubber joint should be used to avoid the transmission and inter-disturbance of vibration and noise to avoid the vibration which may be transmitted to indoor side.
- 10) In close loop water system, to diminish the impact on water pipe because of the expansion or contraction of water volume and to avoid the influence caused by supplementing water pressure, water return side should be fitted with an expansion water tank. The expansion tank shall be installed 1~1.5m higher than the system, and its capacity accounts about 1/10 of the water amount in the whole system.
- 11) The drain connection is arranged on the evaporator cylinder. The drain outlet has been equipped with a 1/2" plug.
- 12) In order to expel the air from water system, install an automatic discharge valve on the highest place of local water pipe and the horizontal pipe should be up tilted for about 1/250 degree.
- 13) The thermometer and pressure gauge are arranged on the straight pipe sections of the water inlet pipeline and drain pipeline, and their installation places shall be far away from the elbows. The pressure gauge installed shall be vertical to the water pipe, and the installation of the thermometer shall ensure that its temperature probe can be inserted into the water pipe directly.
- 14) Each low point shall be fitted with a drain connection so as to drain the remaining water in the system. Before operating the unit, connect the stop valves to the drain pipeline, respectively near the water inlet connection and drain connection. The by-pass pipeline shall be provided between the water inlet pipe and drain pipe of the evaporator, convenient for cleaning and maintenance. Use of flexible connections can reduce vibration transfer.
- 15) The chilled water pipeline and expansion tank shall be subjected to insulation treatment, and the maintenance and operation part shall be reserved on the valve connections.
- 16) After the air-tightness test is carried out, and the insulation layer is applied on the pipeline, so as to avoid heat transfer and surface condensation; the insulation layer shall be covered by moisture-proof seal.
- 17) Any water piping to the unit must be protected to prevent freezing. There are reserved terminals for the auxiliary electrical heater. Logic in PCB will transmit ON/OFF signal by

checking the leaving evaporator water temperature.

Note: The unit only supplies the ON/OFF signal, but not the 220V power. If a separate disconnect is used for the 220V supply to the cooler heating cable, it should be clearly marked so that it is not accidentally shut off during cold seasons.

- 18) If the unit is used as a replacement chiller on a previously existing piping system, the system should be thoroughly flushed prior to unit installation and then regular chilled water analysis and chemical water treatment is recommended immediately at equipment start-up.
- 19) Power on the chilled water pump, and inspect its rotation direction. The correct rotation direction shall be clockwise; if not, re-inspect the wiring of the pump.
- 20) Start the chilled water pump to circulate water flow. Inspect the water pipelines for water leakage and dripping.
- 21) Commission the chilled water pump. Observe whether the water pressure is stable. Observe the pressure gauges at the pump inlet and outlet, and the readings of the pressure gauges and the pressure difference between the inlet and outlet change slightly when the water pressure is stable. Observe whether the operating current of the pump is within the range of rated operating current; inspect whether the resistance of the system is too large if the difference between the operating current and rated value is too big; eliminate the system failures until the actual operating current is satisfied.
- 22) Inspect whether the water replenishing device for the expansion tank is smooth, and the auto discharge air valve in the water system enables auto discharge. If the discharge air valve is a manual type, open the discharge valve of the chilled water pipeline to discharge all air in the pipeline.
- 23) Adjust the flow and inspect whether the water pressure drop of the evaporator meets the requirement of the unit's normal operation. The pressure at the chilled water inlet and outlet of the unit shall be kept at least 0.2MPa.
- 24) The total water quantity in the system should be sufficient to prevent frequent "on-off" cycling. A reasonable minimum quantity would allow for a complete water system turnover in not less than 15 minutes.

3. Wiring installation

WARNING: In order to prevent any accident of injury and death during the site wiring , the power supply shall be cut off before the line is connected to the unit.

Wiring must comply with all applicable codes and ordinances. Warranty is voided if wiring is not in accordance with specifications. An open fuse indicates a short, ground, or overload. Before replacing a fuse or restarting a compressor , the trouble must be found and corrected.

Copper wire is required for all supply lines in field connection to avoid corrosion and overheat at the connection of terminals. The lines and control cables shall be separately paved and equipped with protective pipes to avoid intervention of supply line in control cable.

Power section: It is required to connect the power supply cable to the control cabinet of the unit, when it arrives at the jobsite. The power supply cable is connected to the terminals of L1, L2, L3, N and PE and the terminals need to be fixed again after 24h running (the minimum allowed time). Please seal the entering wiring hole after users installed the main power wires, in order to avoid the dust entering into electric control cabinet.

Caution: it is suggested that to use appropriate tools to make sure that a enough height to install the main power wires if the basement is higher than 200 mm. Breaking isolation switches should be added between the power cord of users and the unit. The capacities of the breaking isolation switches recommended are see electrical control .

- (1) Attention: **refrigerant selection:** the previous software settings are replaced by the current hardware settings to avoid the possibility of improper operation of the software leading to wrongly selected refrigerant and damage to the unit.
- (2) In order to avoid wrong control in field connection, the liquid control circuit (24 V) shall not be in the same conduit with the lead wire with voltage higher than 24 V.
- (3) The control circuits of various units are all 220 V, and for the wiring ways of the control circuits, please refer to the wiring diagrams supplied along with the units.
- (4) A unit consists of master compressor and slave compressor communicating via shield wire protected by sleeve and paved separate from supply line.
- (5) The control output cable to be connected on site shall be AC250V-1mm², and 0.75mm² shield wire (24 V) shall be used for control signal line.
- (6) Attentions: Read the electrical wiring principle diagram and connect the wires strictly according to the wiring terminal diagram. Three-core shield cable (3×0.75mm²) shall be used for the connection of the temperature sensor. Common two-core cable (2×0.75mm²) shall be used for the connection of flow switch to connect to the NO contact of the switch, i.e. the opening point when waterless. Two buttons can be connected to the external of remote start and stop.
- (7) If the customer desires the linked control of the water pump, connect the water pump as shown in the diagram, where an intermediate relay is required. If the function of linked control of water pump is not needed, ensure that the water pump is started before starting the machine.

CAUTION: An independent power supply box needs to be equipped with the power supply of the water pump.

- (8) The wiring ports for remote start/stop, flow switch, cool/warm switch, water pump linked control, alarm indication, etc. are reserved in the electrical cabinet of the unit.
- (9) Passive inching button is used for remote start and stop, and the flow switch must be connected to the NO contact, or the machine cannot be started.

Passive holding switch is used for cool/warm switch, e.g. common selection switch. Controls of large power electrical appliances such as water pump and user electric heating must be interfaced with a relay, or the PCB might be burned. Other outputs can be directly connected to indicator lamps or alarms.

VI. Commissioning

1. Pre start-up

(1) Electrical System Inspection

1) Inspect whether power distribution capacity is compliant with the power of the unit before the first start-up, and whether the diameter of the selected cable can bear the maximum working current of the master compressor.

The max economical conveying distance:

The max loading time in a year (h)	Copper core length(m)
<3000h	264
3000~5000h	294
>5000h	331

2) Inspect whether the electric mode is compliant with that of the unit, three-phase five-line (three phase lines, one zero line and one earth wire, 380V±10%).

3) Inspect whether the maximum phase voltage unbalance is compliant with the requirement, 2% for the maximum permissible phase voltage unbalance and 5% for the phase current balance. The machine must not be started up when the phase voltage unbalance exceeds 2%. If the measured unbalance% is excess, the power supply sector shall be informed of immediately.

4) Inspect whether the supply circuit is the compressor is firmly and properly connected, and tighten it if there is any looseness. The screws might be loose due to the factors such as long-distance transport and hoisting of the master compressor. Or, the electrical elements (e.g. air switch, AC contactor, etc.) in the control cabinet of the master compressor and the compressor might be damaged.

5) Carefully inspect all the electrical lines with a multimeter, and whether the connections are properly installed. Carry out measurement in mega ohm and ensure that there is no short circuit at the shell. Inspect whether the earth wire is properly installed, and whether the insulation resistance to ground exceeds 2MΩ. And inspect whether the supply line meets the requirement of capacity.

6) Inspect whether disconnection switch is installed to the supply line of the supply unit.

7) Carry out complete inspect for all connections of the main circuit in the control cabinet and all external connections of the control circuit before power connection (e.g. oil heater, compressor electronic protection, circulatory water temperature sensor, target-type flow switch connection, water pump linked control, communication line connection, etc.); inspect the bolts of the wiring terminal for looseness. Inspect whether various electric meters and appliances are properly installed, complete and available. Inspect the interior and exterior of the electrical cabinet, especially various wiring ports, for cleanness. If the communication lines of the PCB and control screen are damaged, refer to the diagram below.

8) After the inspection for all the above items is complete, connect the control cabinet and the supply indication lamp will light up, indicating that the oil heater is working. Observe whether the phase loss protection is in normal condition, if it is (green light on), close the single-pole switch in the control cabinet, then the control circuit begins working, and the touch screen and PCB control are put into operation.

9) Before start up the machine, inspect whether the external system of the unit meets the conditions for start-up (e.g. whether the water cooling pump of the system is externally controlled or interlocked with the master compressor, and that the water pump must be started before starting up the master compressor via external control).

10) Inspect whether the compressor overload protection value, which shall not exceed the maximum compressor permissible current value indicated in the nameplate on the compressor, is set correctly. The compressor overload protection value generally equals to the set value of heat relay multiplied by variable ratio of current inductor, which is $(250/5)50$ in the following case.

11) Inspect whether the value of phase loss and reversal protection is set correctly. The over-/under-voltage protection value shall be $\pm 10\%$ of the rated voltage.

(2) Refrigeration System Inspection

1) The discharge line valve and suction line valve of the compressor must be fully open (turn anticlockwise to open) and the cores shall be tightly locked to prevent leakage of refrigerant.

The discharge line valve and suction line valve shall be open (both valves in the figure are closed, and shall be opened before start-up).

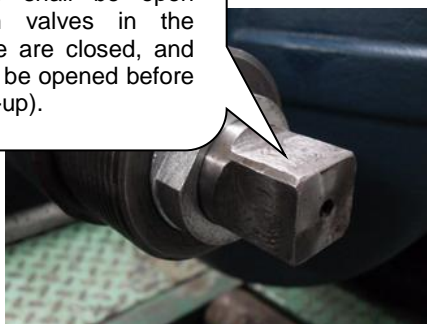

The discharge line valve and suction line valve shall be open (both valves in the figure are closed, and shall be opened before start-up).



2) Inspect whether moisture content of the system exceeds the limit

Excessive moisture content in the refrigerant system of the unit might cause ice block, copper plating, etc. that would seriously affect the safety of the unit. Therefore, the dryness of the refrigerant system of the unit shall be inspected from the sight glass before and during operation of the unit, purple indicating dry, and pink moist, as shown in the right figure. When the color turns red, the filter core in the unit shall be replaced with a dry one.



The color is indicated in the center and compared with the color card around it to reflect the moistness in the system.

3) Sufficient lubricating oil in the oil tank (not lower than 1/2 of the oil level in the high oil immersion lens), and no deterioration (blackness).

Inspect the oil level and quality before start-up for the two factors have direct impact on the performance and reliability of the unit. There must be sufficient lubricating oil in the unit. And during the shutdown of the unit, the high oil immersion lens must be full of oil.

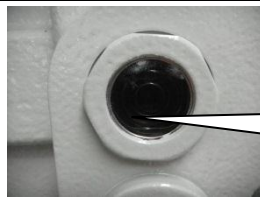

The oil must be full in stop status of the unit, and above the 1/2 position in stable operation.

When the unit is in stable operation, the oil level in the high oil immersion lens should be at least above the 1/2 position. And there shall be no deterioration (blackness) of the lubricating oil, or else, qualified lubricating oil shall be changed before operating the unit.

6) Inspect whether the pressure sensor stop valve, dry filter front/rear angle valve and liquid/air sampling stop valve etc. are all opened.

When the unit stops, the high and low voltages shall be almost the same. After the start-up, the low voltage decreases, and the high voltage increases. If there is no voltage change certain time after the start-up, inspect whether the liquid/air sampling stop valve is open.

7) After the unit is installed and before connected, it is principle required to tighten the connections in the electrical cabinet of the unit one by one.

8) Inspect the bolts of the unit for looseness.

After the unit is transported and installed, it is required to inspect whether the fixing bolts of the unit (e.g. fixing bolts at compressor base angle, at post and beam of the unit, and at pipe clamp, etc.) and of the electrical elements (e.g. fixing bolts of PCB and of insulating transformer, and connection bolts of upper/lower terminals of AC contactor, etc.) are firmly fixed.

9) Inspect the connections in the electrical cabinet for looseness, especially the electric part in the cabinet. The parts connected by bolts might be loose due to transportation. If there is any looseness, tighten it to avoid burnout of circuit or element caused by poor contact.

Inspect the terminals for looseness and poor contact caused by vibration and collision during transportation and installation (especially the electric part; ensure the connection points of all terminals are firm and reliable before electrification).

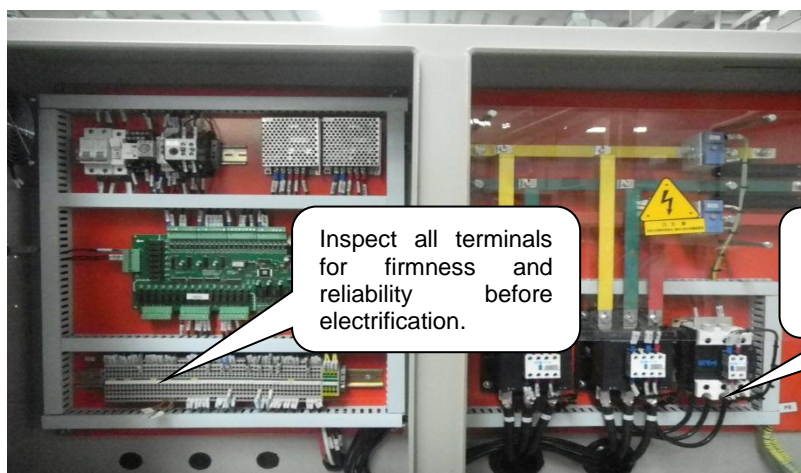

Inspect all terminals for firmness and reliability before electrification.

All connection points of terminals must be firm and reliable.

Inspect whether there is poor contact and short circuit caused by dust, moisture, etc. in the electrical cabinet, and whether the values of all temperature sensors are normal. During the shutdown of the machine, the indicated temperatures of discharge, fin, and the environment shall be almost the same,

and the entering and leaving chilled water temperatures shall be almost the same.

10) Before the unit leaves the factory, the control cabinet is well connected with main motor, electrical actuator, and sensor elements of pressure temperature, etc. Therefore, the wiring on site for the user is very simple. Only the chilled water flow switch line and chilled water pump linked control line (control contact is active) need to be connected. For the detailed connection way, please refer to the circuit wiring diagram in the operation manual for the unit. (The attached circuit diagram represents the case of air-cooled heat pump unit for user's reference, as for the details, the operation manual supplied with the unit shall be final.)

11) Target-type flow control is set on the chilled water pipeline which shall be installed at the chilled water outlet of the unit. The NO contact of the target-type flow control in the chilled water system shall be connected to the control circuit as per the wiring diagram.

Note: Disordered water flow may lead to wrong action of the flow switch; therefore, the control cabinet will command the unit to stop after receiving continuous disconnection signals during 10 s.

12) The tube where the temperature sensing probe is installed shall be filled with lubricating oil or other grease that will not freeze at the temperature of the leaving chilled water for the convenience of heat transfer. Thermostatic insulation and enclosing measures shall be taken for the temperature sensing device.

Inspect whether there is temperature deviation for the entering and leaving water temperature sensor caused by insufficient heat transfer oil in the thermostatic pipe.

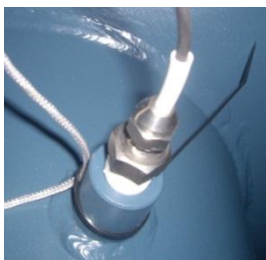

For later armored dip-type temperature sensor, no lubricating oil is required for heat transfer.

2. Start-up

Before start-up of the unit, the following performance parameters need to be inspected:

- (1) High/low voltage value of the system. For the unit shut down and waterless in a long term, the liquid and gas of the system shall be equivalent and close to the saturation pressure corresponding to the current ambient temperature. The correlation of saturation temperatures and pressures (the pressures in the list are gage pressures, among which, the atmospheric pressure is 0.1MPa) of R22 and R134a refrigerant is shown in table 1:



In shutdown status, the high and low voltages shall be the same and equal to the saturation pressure corresponding to the current temperature.

In the pressure gauge scale, taking the right figure for example: the values outside of the black circle are pressure values (unit: bar), and the values of the red, blue and green circles indicate saturation temperatures of refrigerants R404A, R22 and R134a respectively under the relative pressure. The types of refrigerants indicated in different pressure gauges might differ.

[Table 1]

Refrigerant Temperature °C	R134a Refrigerant Pressure (Gage Pressure) MPa
0	0.19
5	0.25
10	0.32
15	0.39
20	0.47
25	0.57
30	0.67
35	0.79
40	0.92

If the high/low voltage deviates much from the saturation pressure corresponding to the current temperature (more than 2bar), leakage or insufficient refrigerant is likely in the system.

- (2) Inspect the unit for normal heating

Before start-up, it is necessary to inspect whether the oil heating in the unit is available, and whether the oil heater does not work when there is oil for heating but no power supply. It is particularly important in winter when the temperature is low and the failure of oil heating might lead to poor lubrication of the unit. The optimum working temperature for current types of lubricating oil is generally around 40°C.



Compressor oil heater begins to work when the unit is electrified.

- (3) Inspect whether there is alarm for trouble of the display screen. if there is, the trouble must be corrected.
- (4) Inspect the electronic expansion valve control module for alarm trouble.
- (5) Inspect whether various temperature points displayed on the display screen are within the normal range.

Before the operation of the unit, the showed temperatures of discharge and fin and the ambient temperature are close to the current actual ambient temperature, and whether the entering and leaving water temperatures are close to the water temperature at the user side. If there is any obvious deviation of the above temperatures, inspect whether the temperature sensor is in normal condition and whether the connection is firm and reliable.

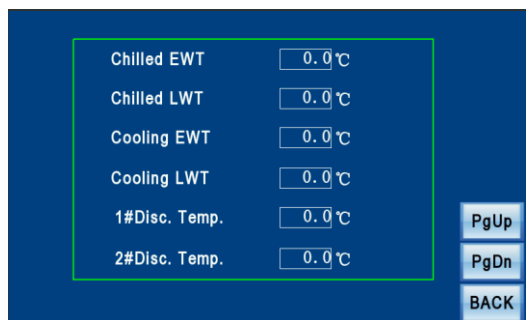

Values of various temperature and pressure points showed in the main page of the unit.

- (6) Inspect whether the flow in the water pump meets the requirements of the unit.
- (7) Inspect whether the power supply of the unit is stable.

2) Parameters Inspections during Start-up and Operation

- (1) The maximum range of parameters for normal operation of R134a refrigerant unit

See table 2 for the maximum range of performance parameters of R134a refrigerant:

[Table 2]

Working Condition	Refrigeration
Discharge temp. °C	40~50°C
Suction temp. °C	5~9°C
Suction super-heating degree °C	1~3°C
Discharge super-heating degree °C	10~15°C
Discharge pressure MPa	0.8~0.9MPa
Suction pressure MPa	0.2~0.25MPa

- (2) Keep good record of unit data during commissioning.

VII. Maintenance

ATTENTION:

All installation parts must be maintained by the personnel in charge, in order to avoid material deterioration and injuries to people. Faults and leaks must be repaired immediately. The authorized technician must have the responsibility to repair the fault immediately. Each time repairs have been carried out to the unit, the operation of the safety devices must be re-checked.

Do not use oxygen to purge lines or to pressurize a machine for any purpose. Oxygen gas reacts violently with oil, grease, and other common substances.

The necessary protection equipment must be available, and appropriate fire extinguishers for the system and the refrigerant type used must be within easy reach.

Do not siphon refrigerant. Avoid spilling liquid refrigerant on skin or splashing it into the eyes. Use safety goggles. Wash any spills from the skin with soap and water. If liquid refrigerant enters the eyes, immediately and abundantly flush the eyes with water and consult a doctor.

Never let an open flame or live steam close to a refrigerant container. Dangerous overpressure can result. If it is necessary to heat refrigerant, only use warm water.

Do not re-use disposable (non-returnable) cylinders or attempt to refill them. It is dangerous and illegal. When cylinders are empty, evacuate the remaining gas pressure, and move the cylinders to a place designated for their recovery. Do not incinerate.

Ensure that you are using the correct refrigerant type before recharging the unit. Charging any refrigerant other than the original charge type (R-22) will impair machine operation and can even lead to a destruction of the compressors. The compressors operating with this refrigerant type are lubricated with a synthetic

Do not climb on a machine. Use a platform, or staging to work at higher levels. Use mechanical lifting equipment (crane, hoist, winch, etc.) to lift or move heavy components. For lighter components, use lifting equipment when there is a risk of slipping or losing your balance. Use only original replacement parts for any repair or component replacement. Consult the list of replacement parts that corresponds to the specification of the original equipment.

1. Daily maintenance

Annual Startup

This is a good time to check all the motor winding resistance to ground. Semi-annual checking and recording of this resistance will provide a record of any deterioration of the winding insulation. All new units have well over 100 MΩ resistances between any motor terminal and ground.

1. The control circuit must be energized at all times, except during service. If the control circuit has been off and oil is cool, energize oil heaters and allow 8 hours for heater to remove refrigerant from the oil before starting.
2. Check and tighten all electrical connections.

3. Replace the drain plug in the cooling tower pump if it was removed at shutdown time the previous season.
4. Install fuses in main disconnect switch (if removed).
5. Reconnect water lines and turn on supply water. Flush condenser and check for leaks.

Annual Shutdown

Where the chiller can be subject to freezing temperatures, the condenser and chiller must be drained of all water. Dry air blown through the condenser will aid in forcing all water out and decreasing the corrosion. Water permitted to remain in the piping and vessels can rupture these parts if subjected to freezing temperature.

If the chiller is used in areas where the ambient temperature will fall below 0°C, forced circulation of antifreeze through the water circuits is one method of avoiding freeze up.

1. Take measures to prevent the shutoff valve in the water supply line from being accidentally turned on.
2. If a cooling tower is used, and if the water pump will be exposed to freezing temperature, be sure to remove the pump drain plug and leave it out so any water that can accumulate will drain away.
3. Open the compressor disconnect switch, and remove the fuses.
4. Check for corrosion and clean and paint rusted surfaces.
5. Clean and flush water tower for all units operating on a water tower. It should be recognized that atmospheric air contains many contaminants that increase the need for proper water treatment. The use of untreated water can result in corrosion, erosion, sliming, scaling or algae formation. It is recommended that the service of a reliable water treatment company be used.
6. Remove condenser heads at least once a year to inspect the condenser tubes and clean if required.

Recommended maintenance schedule

This chapter shows the preventive maintenance of Midea screw chiller. Correct maintenance and timely service will make the chiller in the best condition and with best performance, beside, it can prolong the lifespan of chiller.

The customer has responsibility to appoint qualified equipment management engineer and specially-assigned operator to do the daily and scheduled maintenance. The repair work should be done by big maintenance agency that is qualified to do the job. It's better to make maintenance agreement with local customer service centre of Midea after chiller out of warranty, to keep the chiller always under effective service and guarantee reliable operation.

Note: Repair work caused by incorrect maintenance within warranty will lead to extra charges.

Daily maintenance

The basic work of unit maintenance is to truly record the operation parameters of unit at certain intervals (e.g. 2hours) everyday. Fill the operation parameter table which contains such key parameters as high/low pressure, suction/discharge temperature, degree of sub-cooling/overheat degree. True and complete records of operation parameters are useful for analyzing and forecasting the trend of unit

operation. It's good for finding and forecasting the problem that may occur and taking measures in time. For example, by analyzing the record of a whole month, you may find that the temperature difference of condensing temperature and leaving cooling water temperature may become bigger. It means that the cooling water is dirty or water hardness is big, and it is scaling constantly. So it's compulsory to perform softening process or clean the tubes.

Note: Keeping the normal operation parameters of initial unit commissioning is very useful. It can be used for comparative analysis to find out the trend of problem.

Scheduled maintenance

General

Take notice of the noise at any time by standing 1m from the unit. Watch the vibration amplitude at all times to see whether it's within permitted. Check the voltage of power supply whether it's within $\pm 10\%$ of rated voltage at any time.

➤ **Visual inspection**

Keep the unit clean, if there's rust, do scaling with iron brush and cover it with antirust paint. Pay attention to the oil traces (sign of a refrigerant leak) and water traces on pipeline. Check the threaded connection joints carefully, fasten any loose screw in time. Any time seeing the insulating material flakes off, stick them with adhesive.

➤ **Compressor**

For insulation resistance, check it yearly and it should be over $5M\Omega$ when measuring with ohmmeter of DC 500V. When touching the shockproof rubber, it should be elastic, or it means the rubber gets ageing. Every 3000 hours, make middle inspection of vibration and oil level; every 6000 hours, check the safety device and protective device to guarantee the normal operation.

Important: The normal oil level is at the middle of sight glass. Adding lubricating oil if the oil level decline obviously. Inspect the oil quality monthly to see if there's dirt or deterioration, otherwise, replace the oil and filter core if necessary by specialized technicians. Make chemical analysis of the lubricating oil, if emulsification phenomenon occurs, change the oil of same brand.

➤ **Heat exchangers**

Adjust the water flow to keep the high/low pressure within normal range (high pressure 0.6~1.2MPa/low pressure 0.1~0.4, if the temperature difference between leaving cooling water temperature and refrigerant temperature in condenser is larger than $6\text{ }^{\circ}\text{C}$, it means the condenser is scaling and cleanliness work is in urgent need. When the chiller stops for a long time, water in heat exchangers and pipe system should be drained thoroughly. For newly installed chiller, the filters in water system should be cleaned after running for 24 hours and then clean the filters quarterly.

➤ **Valves and pressure controllers**

▲ Safety valves

Inspect the integrity and performance of valves every year. The maintenance of safety valves should be done by specialized technicians. Take apart the connecting pipe of safety valve, and check it to see

whether there is corrosion, rust, scaling, leakage phenomenon internal (if necessary, replace the safety valve). And also check other operating valves to see whether it's smooth when opening or closing them.

▲ High/low pressure switch

Check their performance whether they are in good condition according to "performance of protection device" monthly, and change the broken one in time. Or the chiller may get damaged when over high pressure or too low pressure happens.

➤ Chilled water cycling

Seek the possible leakage on the unit and the pipe joint with leak detector. Expel the water from condenser and evaporator to see whether there's leakage on water inlet and outlet. Leak can be found with electronic detector, torch detector or soap water. The work looking for refrigerant leakage should be carried out at least once/month.

➤ Electrical control system

For insulation resistance, check it monthly and it should be over 1MΩ when measuring with ohmmeter of 500VDC. Check the running current and compare with the rated value (refer to Table.9). Check the conductivity of wire and verify whether it's intact and well connected. Fasten the loose bolts. Check other components such as electromagnetic contactor, rotary switch, auxiliary relay, time relay and thermostat whether they are all normal monthly.

Training User Operator

The commissioning process includes training user operators in the following aspects:

- 1) Stress the safety in shutdown and operation processes.
- 2) Require the users to carefully read the operation manual of the unit.

Explain to the users that operation of the unit shall be carried out strictly as per the steps and methods specified in the operation manual. If anyone has any problems about descriptions in the manual, he shall enquire after-sale personnel or professionals in the factory and carry out the operation only when he understands it. Any deviation in the installation of the unit from the requirements in the manual shall be pointed out to the part responsible for installation, and the after-sale personnel or professionals in the factory will determine whether change is necessary.

- 3) Short-connection is forbidden when all protection functions of the unit are normal. Ensure all protection functions are available and reliable.

Various protection switches in the unit are for safety of the unit or user, and are not permitted to be short connected in principle. If short-connection is required for commissioning, the operation shall be done by the after-sale personnel or professionals in the factory on site. After the commissioning, connect the protection switches to the system before starting up the unit for long-time running.

- 4) Open the water pump and wait until the water flow is stable before starting up the master compressor. For shutdown, the water pump must be closed in a delayed time. It is not allowed to forcibly close the water pump when the master compressor is still running. If the water pump fails, and the flow switch does not jump, the unit must be emergently shut down.

- 5) The unit must be disconnected from the power supply during inspection or replacement of the lines of the unit.

If it is required to tighten the line bank screw or replacing the wire and element in the electrical cabinet during commissioning and maintenance, it shall be down when the power supply is disconnected. Similar operations by the user in later maintenance and service shall also be done when the power supply is disconnected.

- 6) The non-user parameters in the touch screen of the unit and electronic expansion valve control module are forbidden to be changed.

The non-user parameters in the touch screen of the unit and electronic expansion valve control module are directly related to the performance and reliability of the unit, and are not allowed to be changed in principle. Even if it is required to adjust some parameters due to special local climate, it shall be done by or under the instructions of after-sale personnel or professionals in the factory.

- 7) If any exceptional case occurs to the unit, it is forbidden to forcibly start up the unit unless under the instructions of professionals.

Exceptional temperature, pressure, sound, or vibration, etc. of the unit during the running shall be clearly recorded in details, and reported to after-sale personnel or professionals in the factory. It is forbidden to forcibly start up the unit unless permitted.

2. Maintenance

If the problem is much more serious, contact your local Midea or your local representative for assistance.

Cleaning Heat Exchangers

Check the chiller tightness and whether there's leak of heat exchange tubes. It is necessary to do nondestructive inspection for the principal weld (longitudinal and circumferential weld of evaporator/condenser barrel) of pressure vessel. Inspect and clean cooler tubes at the end of the first operating season. Tube condition in the exchanger will determine the scheduled frequency for cleaning, and will indicate whether water treatment is adequate in the water circuit. Too much scale will cause big loss of capacity and efficiency.

Refer to the following pressure-temperature curve for condition in heat exchangers:

High pressure-cooling water temperature (high pressure beyond 0.6~1.2MPa is abnormal)

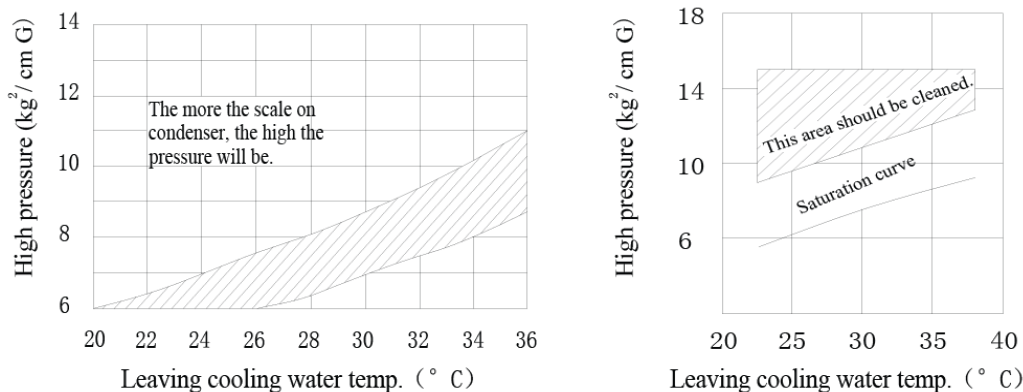

Fig.26 High pressure at full load (standard unit)

Low pressure-chilled water temperature (low pressure beyond 0.14~0.37MPa is abnormal)

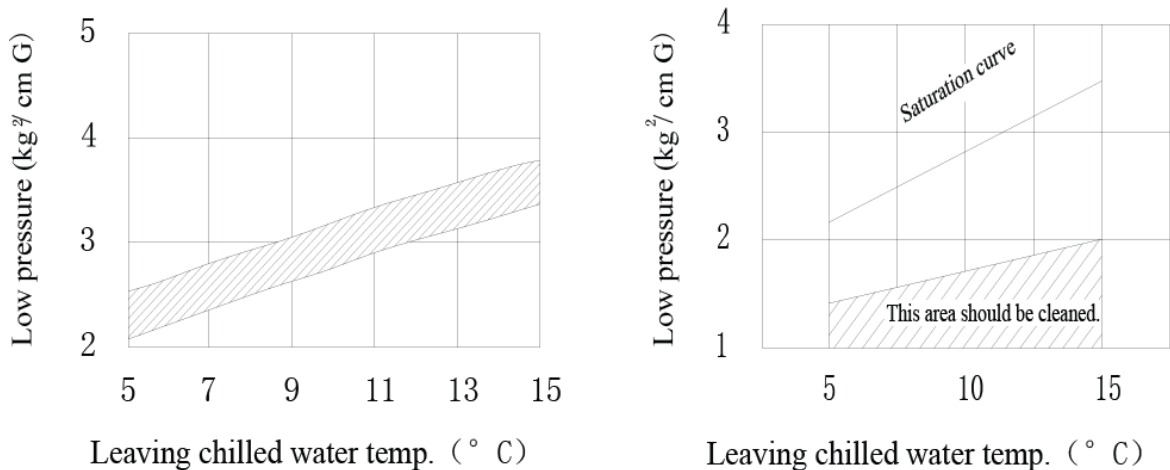

Fig.27 Low pressure at full load (standard unit)

Cleaning work must be done when too much scale found. Physical and chemical cleaning can be chosen according to the device you have. Generally, chemical cleaning is much easier to carry out. Methods are as below and the services of a qualified water treatment specialist should be obtained to develop and monitor a treatment program.

a) Cycle under normal temp. (A):

(Volume of condenser+ volume of pipes+ volume of container)×1/3

Note: concentration of detergent ——33%

b) Cycle under normal temp. (B):

(Volume of cooling tower flume + volume of condenser+ volume of pipes)×1/10

Note: concentration of detergent ——10%

Warning: When doing cleaning with unit stops, volume of cooling tower flume can be 1/2 or 1/3 of rated value; but if doing cleaning with unit is runs, the volume of cooling tower flume should keep rated value. Midea assumes no responsibility for pressure vessel damage resulting from untreated or improperly treated water.

Requirement for cleaning and maintenance

	Water quality	Scale	Corrosion	Remark
1	PH≤6 Acid water	Hard	Strong	Generates insoluble CaSO ₄
2	PH≥8 Alkali water	Soft	——	Soft fluid deposit may be caused by ions iron or aluminum
3	Water with much Ca ²⁺ and Mg ²⁺	Hard	——	Easily generates hard scale.
4	Water with much Cl ⁻	Dirt	Ultra-strong	Corrosive to copper and iron.
5	Water with much SO ₄ ²⁻ and SiO ₂ ²⁻	Hard	Strong	Generates hard CaSO ₄ and CaSiO ₂
6	Water with much Fe ³⁺	Large quantity, hard	Strong	Generates deposits Fe(OH) ₃ and Fe ₂ O ₃
7	Odorous water	Large quantity	Ultra-strong	Generates sulfide, ammonia and marsh gas, especially H ₂ S which has great corrosion to copper.

8	Water with organic substance	Large quantity	—	Easily generates scale
9	Exhaust gas from auto, chemical factory, plating factory, sewage plant, ammonia refrigeration plant and fiber factory		Strong	Copper tubes of condenser may be eroded and perforated.
10	Dusty places such as plastic plant	Large quantity		
11	Sulfurous gas in the air		Ultra-strong	
12	Natural pollution such as damp air near the coast or insects in the field goes into cooling tower.	Large quantity	Strong	

Cycle under normal temp. (A):

(Capacity of condenser+ Capacity of pipe+ Capacity of container) \times 1/3(Thickness of detergent 33%)

Cycle under normal temp. (B):

(Capacity of flume of cooling tower+ Capacity of condenser+ Capacity of pipe) \times 1/10(Thickness of detergent 10%)

In case doing cleaning after the unit stops, the capacity of flume of cooling tower can be 1/2 or 1/3 of rated value; if doing cleaning as the unit is running, the capacity should achieve rated value.

Precautions on usage of detergent

When doing cleaning, please wear rubber gloves and do not expose your skin or your clothes to the detergent. In case touching the detergent, please wash it with clean water.

The container for detergent should be made of plastic or glass rather than lead. The used detergent should be neutralized with lime or soda before draining

Detergent is harmful to human; please keep it away from children.

Turn on the unit after cleaning to ensure it is clean. If necessary, please do cleaning again.

c) Precautions of chemical cleaning

- ✓ When doing cleaning please wear rubber gloves and do not expose your skin or your clothes to the detergent. In case of touching the detergent, please wash with clean water immediately.
- ✓ The container for detergent should be made of plastic or glass rather than lead.
- ✓ The used detergent should be neutralized with lime or soda before draining.
- ✓ Detergent is harmful to human body; please keep it away from children.
- ✓ Turn on the unit to check the effect after cleaning work done. If necessary, please do cleaning again.

Water Treatment

Before every start-up, clean and flush the cooling water circuit. Make sure tower blow-down or bleed-off is operating. It should be recognized that atmospheric air contains many contaminants that increase the need for proper water treatment. The use of untreated water can result in corrosion, erosion, sliming, scaling or algae formation. Midea assumes no responsibility for the results of untreated or improperly treated water.

See appendix 1 for water quality requirements.

Refrigerant Circuit

➤ **Leak testing**

Units are factory-charged with refrigerant R-22 (Refer to the Physical Data tables supplied in the IOM manual book). Leak test must be done under sufficient pressure. This can be done by charging enough refrigerant into the system to build the pressure up to approximately 70 kPa and adding sufficient dry nitrogen to bring the pressure up to a maximum of 850 kPa. Leak test with an electronic leak detector. Water flow through the vessels must be maintained anytime refrigerant is added or removed from the system. If any leaks are found in welded or brazed joints, or it is necessary to replace a gasket, relieve the test pressure in the system before proceeding. Brazing is required for copper joints. After leaks are repaired, system must be evacuated and dehydrated.

➤ **Evacuation**

After it has been determined that there are no refrigerant leaks, the system must be evacuated using a vacuum pump with a capacity that will reduce the vacuum to at least 130Pa (=1mmHg). A mercury manometer, or an electronic or other type of micron gauge, must be connected at the farthest point from the vacuum pump. For readings below 130Pa, an electronic or other micron gauge must be used. The triple evacuation method is recommended and is particularly helpful if the vacuum pump is unable to obtain the desired 130Pa of vacuum. The system is first evacuated to approximately 660Pa (=5mmHg). Dry nitrogen is then added to the system to bring the pressure up to zero.

Then the system is once again evacuated to approximately 230Pa(=2mmHg). This is repeated three times. The first pull down will remove about 90% of the non-condensable, the second about 90% of that remaining from the first pull down and, after the third, only 0.2% non-condensable will remain.

➤ **Checks on refrigerant charge**

To verify if the unit is operating with the correct refrigerant charge, perform the following checks.

1. Run the unit at maximum operating load.
2. Check the leaving chilled water temperature to be between 6~8°C.
3. Check the entering cooling water temperature to be between 25 and 32°C.
4. Under the above mentioned conditions verify the following items.
 - a) The sub-cooling to be between 4 and 6°C
 - b) The difference between leaving water temperature and evaporating temperature to be in 4~6°C range.
 - c) The difference between condensing temperature and condenser leaving water temperature to be in 0.2~3°C range.
 - e) The evaporator refrigerant level slightly laps last tubes row by checking the sight glass installed on each evaporator for a visual inspection.
 - f) The condenser refrigerant level to be included between the condensing and the sub-cooling sections by checking the sight glass installed on each condenser for a visual inspection.
5. Verify the sight glass on the liquid piping to be fully charged. If one of the above parameters exceeds the limits, unit may require an additional refrigerant charge.

Note: Refrigerant removing and drain operation must be performed by qualified personnel using correct material. Inappropriate maintenance could lead to refrigerant or pressure loss. Do not discharge the refrigerant or the lubricant oil into the environment. Always use a proper recovery system.

Refer to Physical Data tables supplied in the IOM manual book). Immediately ahead of orifice baffle (see Fig.) is a factory-installed liquid line service angle valve. Each angle valve has a 1 5/8-in. threaded connection for charging liquid refrigerant. Connect the refrigerant drum to the gauge port on the liquid line shutoff valve and purge the charging line between the refrigerant cylinder and the valve. Then open the valve to the mid-position.

Turn on both the cooling tower water pump and chilled water pump and allow water to circulate through the condenser and the chiller.

IMPORTANT: When adding refrigerant to the unit, circulate water through evaporator continuously to prevent freezing and possible damage to the evaporator. Do not overcharge, and never charge liquid into the low-pressure side of system.

If the system is under a vacuum, stand the refrigerant drum with the connection up, and open the drum and break the vacuum with refrigerant gas to a saturated pressure above freezing.

With a system gas pressure higher than the equivalent of a freezing temperature, invert the charging cylinder and elevate the drum above the condenser. With the drum in this position, valves open, water pumps operating, liquid refrigerant will flow into the condenser. Approximately 75% of the total requirement estimated for the unit can be charged in this manner.

After 75% of the required charge has entered the condenser, reconnect the refrigerant drum and charging line to the service valve on the bottom of the evaporator. Again purge the connecting line, stand the drum with the connection up, and place the service valve in the open position.

Before replacing electronic expansion valve or thermal expansion valve of the system, pressure sensor sampling shut valve, low pressure pipeline, etc. force the refrigerant in the liquid part of the system.

The particular steps are: (take careful consideration before continuing with the following steps)

- a Close the dry filter angle valve of the system.
- b Start up the unit, and emergently stop the unit when the gas in the system is below 0.5bar.
- c Close the liquid/air valve of the compressor.
- d Discharge the residual refrigerant in the gas system.
- e Carry on replacement of the parts of the system.
- f After the replacement, extract vacuum in the gas part.
- g After the vacuum extraction, keep the negative voltage until the resumed vacuum in the unit meets the requirements.
- h Open the angle valve of liquid system and compressor liquid/air stop valve to ensure the loop of the entire system is unobstructed.
- i Add proper amount of refrigerant, generally 5~10k.

Compressor Oil System

Each compressor/circuit has its own oil system which includes an oil filter, oil solenoid valve, Venturi tube, oil separator heater, and an oil shut-off valve. A typical oil system is shown in Fig. 34. See Table 33 for oil

charge Quantities.



Fig. 34.

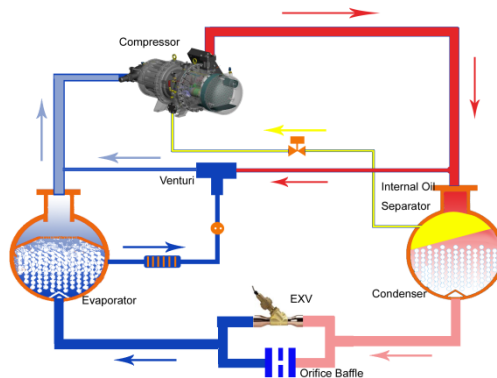

Each screw compressor is connected to a tank (oil separator) separating and collecting the oil from discharge gas. The discharge gas pressure pushes the oil back into the compressor for compressor seal and lubrication of all moving parts. During the compression, the oil joints the discharge gas before being conveyed again into the oil separator and re-start the cycle. The oil flow is granted by the pressure difference created between the condenser and the evaporator. This difference depends on the cooling water and evaporator water temperatures. During the start-up it is vital to establish rapidly the appropriate temperature difference, by checking the right cooling water temperature. The head of cooling water pump at zero flow rate should not exceed the maximum working pressure of condenser and plant water side.

Oil recovery system

Each compressor includes a system to recover the oil accumulated inside the evaporator during the normal operation. This system consists of a jet pump able to collect continuously all the oil from the evaporator preventing from the accumulation due to the low speed refrigerant gas. The high-pressure discharge gas feeds the jet pump that creates a depression, which allows the suction of the oil refrigerant mixture from the evaporator into the compressor to re-establish the oil level inside the lubrication system. On the oil recovery piping a sight glass allows to check the oil-gas mixture flow to the compressor. If flow is insufficient or the unit continuously stops for “Low Oil Level” alarm, verify the correct operation of the corresponding circuit.

Oil Charging/Low Oil Recharging

Pre-cautions in changing of oil

1. Use only qualified oil and do not mix different brand of oil together. Different kinds of refrigerant should match different kinds of oil, note that some synthetic oil is incompatible with mineral oil.
2. When using the synthetic oil for the chiller system, be sure not to expose the oil to atmosphere for a long time, it is also necessary to vacuum the system completely when installing the compressor.
3. In order to ensure no moisture inside the system, it is suggested to clean the system by charging it with dry Nitrogen and then vacuum the system repeatedly as long as possible.
4. It is essential to change for new oil especially after the motor burns out; the acidity debris still remain inside the system so clean work must be done to overhaul the system. Check the oil acidity after 72 hours of operation and then change it again until the oil acidity is in the standard value.
5. Contact local distributor/agent for concerning unqualified oil to be used.

➤ Oil change

1. Change oil periodically: Check the lubrication oil for every 10,000 hours of continuous running. For the first operation of the compressor, it is recommended to change oil and clean oil filter after running at 2,000 hours. Check the system whether clean or not and then change the oil every 20,000 hours or after 3 years of continuous running while the system is operated under good condition.
2. Avoid the debris or swarf clogging oil filter, this may caused bearings failure. The oil pressure differential switch will trip when the oil pressure differential reaches the critical point (default: 150kPa). The compressor will automatically shut down to prevent the bearings from getting damaged due to the lack of lubricating oil.

Caution

Compressor oil is pressurized. Use proper safety precautions when relieving pressure.

➤ Oil Filter Maintenance

Each compressor has its own internal oil filter and each circuit also has an in-line external filter located under the external oil separator. The internal oil filter pressure drop should be checked and filter changed (if necessary) after the initial 2000 hours of compressor operation. Oil line pressure loss is monitored by the control and reported for each compressor as the oil filter pressure drop.

Normally the pressure differential (discharge pressure minus oil pressure) is typically less than 150kPa for a system with clean internal and external filters. To determine the oil pressure drop due to the oil lines and external filter only, connect a gage to the oil pressure bleed port. Compare this value to the discharge pressure read at the touch screen. If this value exceeds 150 kPa, replace the external filter.

✚ Moisture-Liquid Indicator

Clear flow of liquid refrigerant indicates sufficient charge in the system. Note, however, that bubbles in the sight glass do not necessarily indicate insufficient charge. Moisture in the system is measured in parts per million (ppm), changes of color of indicator are:

Green—moisture is below 80 ppm;

Yellow-green (chartreuse)—80 to 225 ppm (caution);

Yellow (wet)—above 225 ppm.

Change filter drier at the first sign of moisture in the system.

IMPORTANT: Unit must in operation for at least 12 hours before moisture indicator can give an accurate reading. With the unit running, the indicating element must be in contact with liquid refrigerant to give true reading.

✚ Relief Devices

➤ Pressure relief valves

Relief valves are installed on evaporator, condenser and oil separator. These valves are designed to relieve if an abnormal pressure condition arises. Relief valves on condenser relieve at 2.07MPa. These valves should not be capped. If a valve relieves, it should be replaced. If not replaced, it may relieve at a lower pressure compared to the set point, or leak due to trapped dirt from the system which may prevent resealing.

VIII. Troubleshooting

1. Protection items

Midea screw chiller has many protection measures and devices. There're many features to aid in troubleshooting. By using the alarm information, DI/O, AI/O and operating conditions of the chiller during chiller operation, it's convenient to find the possible problem. Verify that the chiller is properly configured, including options and/or accessories.

Protection items:

Protection	Purpose
High pressure / low pressure protection of compressor	Ensures the compressor runs in normal range and ensures its work life.
Converse phase, lack of phase protection	Protects the compressor from damage because of converse phase or lack of phase of power.
Anti-freezing protection during refrigeration	Protects the key components such as evaporator, condenser and water pipe etc. from damage because of the expanse caused by the water becomes into ice
Overload protection	Protects the compressor from burn due to overload running.
Over current protection of compressor	Protects the compressor from burn due to over current running under bad conditions.
Internal protection	Makes the compressor run safely under permitted conditions.
Anti-overheating protection of system	Protects the compressor from burn because of running lack of refrigerant or lubricating oil.
Water flow switch protection	Protects the compressor and the water pump motor from burn because there is lack of cooling water or chilled water.
Protection of sensor fault	Ensures the data from sensor is correct to prevent the system from wrong action.
Oil level and oil pressure difference protection	Ensures the compressor to run normally.
High discharge temperature protection	Makes the compressor run safely under permitted conditions.

➤ Phase reversal/phase loss (phase protection)

Power supply A/B/C should exist simultaneously and differ from each other by 120° phase angle. If not, Phase reversal or phase loss fault will occur and be displayed on screen. Before unit start when Phase reversal or phase loss fault occurs, the chiller won't start; when Phase reversal or phase loss fault occurs during chiller operating, the chiller will stop according to protective stop program. Both compressors are shut down and water pumps and cooling tower fan stops in accordance with normal shutdown procedure. When fault record gets cleared and both temperature and time condition gets satisfied, the chiller can restart.

➤ Water flow failure (both chilled water and cooling water)

PCB controller begins to detect chilled/cooling water flow switch after water pumps get energized 180s. The switch will disconnect if water flow less than set point and water flow loss signal will generate if it lasts for 5s. During chiller operation (including dual heads unit), any flow switch disconnects for 5s continuously, Unit stops according to protective stop program.

If chilled water flow fails, chilled water pump stops after 30s delay; cooling water pump and cooling tower stops after 60s delay.

If cooling water flow fails, cooling water pump and cooling tower stops after 60s delay; chilled water pump stops after 600s delay.

Note: fault can be cleared after power re-energized and it needs to be confirmed manually, then when both temperature and time condition gets satisfied, the chiller can restart.

➤ Temperature sensor failure

Entering chilled water temperature sensor short circuit/open circuit, display entering chilled water temperature fault and chiller stops according to abnormal shutdown program. After the sensor reset, fault on screen must be cleared manually; when both temperature and time condition gets satisfied, the chiller can restart.

Leaving chilled water temperature sensor short circuit/open circuit, display leaving chilled water temperature fault and chiller stops according to abnormal shutdown program. After the sensor reset, fault on screen must be cleared manually; when both temperature and time condition gets satisfied, the chiller can restart.

Entering cooling water temperature sensor short circuit/open circuit, display entering cooling water temperature fault and chiller stops according to abnormal shutdown program. After the sensor reset, fault on screen must be cleared manually; when both temperature and time condition gets satisfied, the chiller can restart.

Leaving cooling water temperature sensor short circuit/open circuit, display leaving cooling water temperature fault and chiller stops according to abnormal shutdown program. After the sensor reset, fault on screen must be cleared manually; when both temperature and time condition gets satisfied, the chiller can restart.

Discharge temperature sensor short circuit/open circuit, display discharge temperature fault and chiller stops according to abnormal shutdown program. After the sensor reset, fault on screen must be cleared manually; when both temperature and time condition gets satisfied, the chiller can restart.

Oil temperature sensor short circuit/open circuit, display oil temperature fault and chiller stops according to abnormal shutdown program. After the sensor reset, fault on screen must be cleared manually; when both temperature and time condition gets satisfied, the chiller can restart.

➤ Over/under voltage

When power supply voltage is less than 90% or more than 110%, corresponding alarm over voltage or under voltage occurs. The chiller will stop immediately according to abnormal shutdown program. Fault on screen must be cleared manually; when both temperature and time condition gets satisfied, the chiller can restart.

➤ High/low pressure protection

Alarm as soon as high pressure switch trips and stop the chiller immediately according to abnormal shutdown program. It is one kind of NC switch and needs manual reset of the red reset button when

fault happens. Fault on screen must be confirmed and cleared manually; when both temperature and time condition gets satisfied, the chiller can restart.

When suction pressure is lower than the protective low pressure set point (effective for time delay), stop according to abnormal shutdown program. After the switch reset, fault on screen must be confirmed and cleared manually; when both temperature and time condition gets satisfied, the chiller can restart.

➤ Anti-freeze protection

Over low leaving chilled water temperature

When leaving chilled water temperature gets lower than 4°C, perform low water temperature protection and stop according to abnormal protective shutdown program. Cooling water pump/chilled water pump/cooling tower fan keeps on running. When leaving chilled water temperature gets higher than 10°C, unit resets. When both temperature and time condition gets satisfied, the chiller can restart.

➤ Mechanical antifreeze switch

The switch trips when leaving chilled water temperature $\leq 3^{\circ}\text{C}$ and chiller stops according to abnormal protective shutdown program. Reset at 10°C and fault on screen must be cleared manually; when both temperature and time condition gets satisfied, the chiller can restart.

➤ Compressor motor protection

Alarm when compressor protection module trips. Perform abnormal protective shutdown program immediately. Fault on screen must be confirmed and cleared manually; when both temperature and time condition gets satisfied, the chiller can restart.

➤ Compressor overload protection

Thermal overload relay trips when heat storage reaches trip point. Faulted compressor will stop immediately to abnormal protective shutdown program and other normal system will keep on running. After the switch reset, fault on screen must be confirmed and cleared manually; when both temperature and time condition gets satisfied, the chiller can restart.

➤ Oil level protection

During unit running, if oil level keeps on lower than set point for 30s, the unit will stop immediately according to abnormal protective shutdown program. After the switch reset, fault on screen must be confirmed and cleared manually; when both temperature and time condition gets satisfied, the chiller can restart

➤ High cooling leaving water temperature protection

When leaving cooling water temp. is higher than 45°C during unit operating, the chiller will stop immediately according to abnormal protective shutdown program. Reset at 38°C and it needs to be confirmed and cleared manually; when both temperature and time condition gets satisfied, the chiller can restart.

2. Troubleshooting

No.	Alarm	Trouble Description	Action	Reset Type	Possible Cause
1	Power Failure Protection	Phase sequence relay switches OFF	Compressor cannot work; The compressor stop running immediately	Reset manually on the touch screen	The power quality is poor, there may exist phase inversion, lacking phase or phase imbalance.
2	Compressor Motor Protection	Compressor motor module switches OFF	Compressor cannot work; The compressor stop running immediately	Power off the unit and re-up electricity, reset manually on the touch screen	1.The power of motor is poor, there may exist phase inversion, lacking phase, over-voltage, under-voltage 2. The motor overheat
3	Compressor Overload Protection	Excess current and cumulate energy make the thermal relay trip	The compressor stop running immediately	Reset manually on the touch screen	1,The compressor continue running in bad condition, over-current 2,The setting value of thermal relay too low
4	Contactors Protection	The coil of contactor does not suction normally	The compressor stop running immediately	Reset manually on the touch screen	1.The suction of the contactor is abnormal when Y type switch to Δ type 2.The vibration during operation cause the contact to loosen
5	Anti-freeze Protection	Anti-freeze switch OFF	The compressor stop running immediately	Reset manually on the touch screen	1,The chilled water flow fall sharply, the water temperature too low 2,Anti-freeze switch is damaged or wiring connection is abnormal
6	Water Flow Fault	The water flow switch continue disconnecting more than 5s	1.Compressor cannot work; The compressor stop running immediately ; 2. Chilled water flow failure: The chilled water pump stop working after 30s delay; Cooling water pump and cooling tower shut down after 120s delay 3.Cooling water flow failure: The cooling water pump and cooling tower shut down after 30s delay; chilled water pump stop working after 180s delay.	Power off the unit and re-up electricity, reset manually on the touch screen	1,The water pump failure, the water flow too small 2,Water flow switch failure or wrong wiring connection

Flooded type water cooled screw chiller (PCB Control)

7	High-pressure Protection	High pressure switch OFF	The compressor which exists protection stop running immediately; Other compressors continue running	Press red reset button, reset manually on the touch screen	<ul style="list-style-type: none"> 1,The cooling water quality is too bad and the heat exchange of condenser is abnormal 2,There is too much non-condensable gas in the system 3,The cooling water flow too small or the temperature too high 4,Too much refrigerant 5,Wrong refrigerant type 6,The discharge shutoff valve does not open fully
8	Low-pressure Protection	The low pressure switch continue disconnecting more than 3s (setting is allowed)	<ul style="list-style-type: none"> 1.The compressor which exists protection stop running immediately; Other compressors continue running 2.If the protection occurs before the unit starts to work, all of the compressors in the unit cannot run. 	Reset manually on the touch screen	<ul style="list-style-type: none"> 1,The refrigerant not enough 2,EXV failure, cannot work abnormally 3,The delay time of low pressure switch alarm too short 4,There is plugging in the filter 5,Some water enter the refrigerant system in evaporator 6,Poor system matching(the evaporator too small or the compressor too large) 7,There is too much oil in the system 8,Chilled water flow too small or the temperature too low
9	Low Oil Level Protection	The oil level switch continue disconnecting more than 60s (setting is allowed)	The compressor which exists protection stop running immediately; Other compressors continue running	Reset manually on the touch screen	<ul style="list-style-type: none"> 1,Too low oil temperature when starting lead to too low pressure difference and return oil is abnormal 2,Return oil solenoid valve failure or plugging in the filter 3,Mix different oil types and return oil system is abnormal 4,Oil level switch failure or wrong wiring connection 5. The oil volume not enough

Flooded type water cooled screw chiller (PCB Control)

10	High Discharge Temperature Protection	The compressor discharge temperature is greater than the setting value	The compressor which exists protection stop running immediately; Other compressors continue running	The protection is relieved once the discharge temperature is lower than the setting value and reset manually on the touch screen	1,The superheat too high(the refrigerant not enough, EXV failure) 2,The discharge pressure too high 3,The oil level too low and the oil volume in the system too small 4,Running in bad condition, too high compression ratio , no auxiliary cooling 5,Bearing or screws are damage 6,Poor system matching
11	Low Chilled Leaving Water Temperature Protection	The chilled water temperature is lower than the setting value	The compressor stop running immediately	No display. Reset automatically when the water temperature is greater than the setting value	1,The chilled water flow not enough 2,The unit continue running in under load condition
12	High Cooling Entering Water Temperature Protection	The cooling water temperature is greater than the setting value	The compressor stop running immediately	No display. Reset automatically when the water temperature is greater than the setting value	1,The cooling tower can not work normally 2,The cooling water flow not enough
13	Chilled Entering Water Temperature Sensor Failure	Chilled entering water temperature sensor is abnormal (open circuit or short circuit)	The compressor stop running immediately	Reset manually on the touch screen	1.The temperature sensor failure 2.The wiring connection is not correct 3.The wiring line is abnormal, has been damaged
14	Cooling Leaving Water Temperature Sensor Failure	Cooling leaving water temperature sensor is abnormal (open circuit or short circuit)	The compressor stop running immediately	Reset manually on the touch screen	1.The temperature sensor failure 2.The wiring connection is not correct 3.The wiring line is abnormal, has been damaged
15	Cooling Entering Water Temperature Sensor Failure	Cooling entering water temperature sensor is abnormal (open circuit or short circuit)	The compressor stop running immediately	Reset manually on the touch screen	1.The temperature sensor failure 2.The wiring connection is not correct 3.The wiring line is abnormal, has been damaged
16	Chilled Leaving Water Temperature Sensor Failure	Chilled leaving water temperature sensor is abnormal (open circuit or short circuit)	The compressor stop running immediately	Reset manually on the touch screen	1.The temperature sensor failure 2.The wiring connection is not correct 3.The wiring line is abnormal, has been damaged

IX. Appendix 1

1. Temperature-Resistance characteristic sheet for discharge temperature sensor

NTC sensor characteristic sheet

Unit: Temp:°C--K.Ratio:KΩ, 5K@90°C

Temp.	Ratio	Temp.	Ratio	Temp.	Ratio	Temp.	Ratio
-20	542.7	20	68.66	60	13.59	100	3.702
-19	511.9	21	65.62	61	13.11	101	3.595
-18	483	22	62.73	62	12.65	102	3.492
-17	455.9	23	59.98	63	12.21	103	3.392
-16	430.5	24	57.37	64	11.79	104	3.296
-15	406.7	25	54.89	65	11.38	105	3.203
-14	384.3	26	52.53	66	10.99	106	3.113
-13	363.3	27	50.28	67	10.61	107	3.025
-12	343.6	28	48.14	68	10.25	108	2.941
-11	325.1	29	46.11	69	9.902	109	2.86
-10	307.7	30	44.17	70	9.569	110	2.781
-9	291.3	31	42.33	71	9.248	111	2.704
-8	275.9	32	40.57	72	8.94	112	2.63
-7	261.4	33	38.89	73	8.643	113	2.559
-6	247.8	34	37.3	74	8.358	114	2.489
-5	234.9	35	35.78	75	8.084	115	2.422
-4	222.8	36	34.32	76	7.82	116	2.357
-3	211.4	37	32.94	77	7.566	117	2.294
-2	200.7	38	31.62	78	7.321	118	2.233
-1	190.5	39	30.36	79	7.086	119	2.174
0	180.9	40	29.15	80	6.859	120	2.117
1	171.9	41	28	81	6.641	121	2.061
2	163.3	42	26.9	82	6.43	122	2.007
3	155.2	43	25.86	83	6.228	123	1.955
4	147.6	44	24.85	84	6.033	124	1.905
5	140.4	45	23.89	85	5.844	125	1.856
6	133.5	46	22.89	86	5.663	126	1.808
7	127.1	47	22.1	87	5.488	127	1.762
8	121	48	21.26	88	5.32	128	1.717
9	115.2	49	20.46	89	5.157	129	1.674
10	109.8	50	19.69	90	5	130	1.632
11	104.6	51	18.96	91	4.849		
12	99.69	52	18.26	92	4.703		
13	95.05	53	17.58	93	4.562		
14	90.66	54	16.94	94	4.426		
15	86.49	55	16.32	95	4.294		
16	82.54	56	15.73	96	4.167		
17	78.79	57	15.16	97	4.045		
18	75.24	58	14.62	98	3.927		
19	71.86	59	14.09	99	3.812		

2. Temperature-Resistance characteristic sheet for water temp. sensor, ambient temp. sensor, oil temp. sensor.**NTC sensor characteristic sheet**

Unit: Temp:°C--K . Ratio:KΩ, 10K@25°C

Temp.	Ratio	Temp.	Ratio	Temp.	Ratio	Temp.	Ratio
-20	103.882	20	12.598	60	2.383	100	0.623
-19	97.868	21	12.023	61	2.296	101	0.605
-18	92.246	22	11.478	62	2.213	102	0.587
-17	86.987	23	10.961	63	2.134	103	0.570
-16	82.065	24	10.470	64	2.057	104	0.553
-15	77.457	25	10.005	65	1.984	105	0.537
-14	73.106	26	9.564	66	1.913	106	0.521
-13	69.031	27	9.146	67	1.846	107	0.506
-12	65.211	28	8.749	68	1.781	108	0.492
-11	61.629	29	8.372	69	1.718	109	0.478
-10	58.270	30	8.013	70	1.659	110	0.464
-9	55.099	31	7.669	71	1.601		
-8	52.123	32	7.342	72	1.546		
-7	49.328	33	7.031	73	1.492		
-6	46.703	34	6.735	74	1.441		
-5	44.235	35	6.453	75	1.392		
-4	41.896	36	6.183	76	1.346		
-3	39.697	37	5.927	77	1.301		
-2	37.628	38	5.683	78	1.258		
-1	35.682	39	5.450	79	1.217		
0	33.849	40	5.228	80	1.177		
1	32.115	41	5.016	81	1.139		
2	30.483	42	4.813	82	1.101		
3	28.944	43	4.620	83	1.066		
4	27.494	44	4.436	84	1.031		
5	26.126	45	4.261	85	0.998		
6	24.833	46	4.092	86	0.966		
7	23.613	47	3.932	87	0.935		
8	22.461	48	3.778	88	0.906		
9	21.373	49	3.632	89	0.877		
10	20.344	50	3.492	90	0.850		
11	19.365	51	3.357	91	0.823		
12	18.438	52	3.229	92	0.798		
13	17.563	53	3.106	93	0.773		
14	16.734	54	2.989	94	0.749		
15	15.950	55	2.876	95	0.727		
16	15.205	56	2.769	96	0.704		
17	14.500	57	2.666	97	0.683		
18	13.831	58	2.568	98	0.662		
19	13.198	59	2.473	99	0.643		

3. Temperature-Resistance characteristic sheet for EXV temp. sensor.

NTC Sensor characteristic sheet

Unit: Temp:°C--K. Ratio:KΩ10K@25°C

Temp.	Ratio	Temp.	Ratio	Temp.	Ratio	Temp.	Ratio
-20	67.74	20	12.09	60	3.02	100	0.97
-19	64.54	21	11.63	61	2.92	101	0.94
-18	61.52	22	11.20	62	2.83	102	0.92
-17	58.66	23	10.78	63	2.75	103	0.90
-16	55.95	24	10.38	64	2.66	104	0.87
-15	53.39	25	10.00	65	2.58	105	0.85
-14	50.96	26	9.63	66	2.51	106	0.83
-13	48.65	27	9.28	67	2.43	107	0.81
-12	46.48	28	8.94	68	2.36	108	0.79
-11	44.41	29	8.62	69	2.29	109	0.77
-10	42.25	30	8.31	70	2.22	110	0.75
-9	40.56	31	8.01	71	2.16		
-8	38.76	32	7.72	72	2.10		
-7	37.05	33	7.45	73	2.04		
-6	35.43	34	7.19	74	1.98		
-5	33.89	35	6.94	75	1.92		
-4	32.43	36	6.69	76	1.87		
-3	31.04	37	6.46	77	1.81		
-2	29.72	38	6.24	78	1.76		
-1	28.47	39	6.03	79	1.71		
0	27.28	40	5.82	80	1.66		
1	67.74	41	5.63	81	1.62		
2	26.13	42	5.43	82	1.57		
3	25.03	43	5.25	83	1.53		
4	23.99	44	5.08	84	1.49		
5	22.99	45	4.91	85	1.45		
6	22.05	46	4.74	86	1.41		
7	21.15	47	4.59	87	1.37		
8	20.29	48	4.44	88	1.33		
9	19.40	49	4.30	89	1.30		
10	18.70	50	4.16	90	1.26		
11	17.96	51	4.02	91	1.23		
12	17.24	52	3.90	92	1.20		
13	16.55	53	3.77	93	1.16		
14	15.90	54	3.65	94	1.13		
15	15.28	55	3.53	95	1.10		
16	14.68	56	3.42	96	1.08		
17	14.12	57	3.31	97	1.05		
18	13.57	58	3.21	98	1.02		
19	13.06	59	3.11	99	0.99		

4. Temperature-Resistance characteristic sheet for EXV temp. sensor.

NTC Sensor characteristic sheet

Unit: Temp: °C--K. Ratio:KΩ 50K@25°C

Temp.	Ratio	Temp.	Ratio	Temp.	Ratio	Temp.	Ratio
-40	1630,77						
-35	1178,11						
-30	860,97						
-25	636,08						
-20	474,78						
-15	357,83						
-10	272,18						
-5	208,83						
0	161,56						
5	125,97						
10	98,96						
15	78,29						
20	62,37						
25	50,00						
30	40,34						
35	32,73						
40	26,71						
45	21,92						
50	18,08						
55	14,99						
60	12,48						
65	10,44						
70	8,78						
75	7,41						
80	6,28						
85	5,34						
90	4,56						
95	3,91						
100	3,37						
105	2,91						
110	2,52						
115	2,19						
120	1,91						
125	1,67						
130	1,46						
135	1,28						
140	1,13						
145	1,00						
150	0,89						