



# INSTALLATION MANUAL

## *COMPRESSOR CONDENSING UNIT*

MCCU-03CN1A  
MCCU-05CN1A  
MCCU-07CN1A  
MCCU-10CN1  
MCCU-12CN1  
MCCU-16CN1

Thank you very much for purchasing our air conditioner,  
Before using your air conditioner, please read this manual carefully and keep it for future reference.



## CONTENTS

PRECAUTIONS.....	1
OUTDOOR UNIT INSTALLATION.....	2
INSTALL THE CONNECTING PIPE.....	3
REFRIGERANT PIPE.....	4
HEAT INSULATION OF THE PIPE .....	4
CONNECTIVE DIAGRAM.....	5
CONTROL.....	6
WIRING.....	6
ELECTRIC CONNECTION.....	7
ELECTRIC WIRE DIAGRAM .....	7
TRIAL RUN .....	8

## 1. PRECAUTIONS

Precautions before reading the installation manual.

- Read this user manual carefully before installing the equipment.
- The air conditioner must be installed by professional technicians.
- Inspect and make sure the piping and cabling are correct before powering on the air conditioner.
- This information may change with the update of this machine, and no further notice will be given for such change.



### WARNING

Failure to observe a warning may result in death.



### CAUTION

Failure to observe a caution may result in injury or damage to the equipment.

After completing the installation, make sure that the unit operates properly during the start-up operation. Please instruct the customer on how to operate the unit and keep it maintained. Also, inform customers that they should store this installation manual along with the owner's manual for future reference.



### WARNING

- Decide the correct way of conveying the equipment.
- Try to transport this equipment with the original package.
- If the air conditioner needs to be installed on a metal part of the building, electric insulation must be performed, and the installation must meet the relevant technical standards of electric devices.
- **The appliance must be installed 2.3m above floor.**
- **The appliance shall not be installed in the laundry.**
- **Before obtaining access to terminals, all supply circuits must be disconnected.**

- **The appliance must be positioned so that the plug is accessible.**
- **The enclosure of the appliance shall be marked by word, or by symbols, with the direction of the fluid flow.**
- **If the supply cord is damaged, it must be replaced by the manufacture or its service agent or a similarly qualified person in order to avoid a hazard.**
- **An all-pole disconnection switch having a contact separation of at least 3mm in all poles should be connected in fixed wiring.**



### CAUTION

- Before installing the unit, it is necessary to check whether the ground wire is charged. If it is, the unit shall not be installed before correction.
- Before installing the unit, be sure to confirm with the user whether there are wires, water pipes, air pipes and so on in the wall or ground of the installation site to avoid accidents due to damage.
- Install the unit where enough space of installation and maintenance is available.
- Install the unit where the air inlet and outlet are not baffled and are the least affected by external air.
- Install the unit where it is easy to lead out the connective pipe.
- Install the unit where no heat is emitted from a heat source directly.
- Installing the equipment in any of the following places may lead to faults of the equipment (if that is inevitable, consult the supplier):
  - The site contains mineral oils such as cutting lubricant.
  - Seaside where the air contains much salt.
  - Hotpring area where corrosive gases exist, e.g., sulfide gas.
  - Factories where the supply voltage fluctuates seriously.
  - Inside a car or cabin.
  - Place like kitchen where oil permeates.
  - Place where strong electromagnetic waves exist.
  - Place where flammable gases or materials exist.
  - Place where acid or alkali gases evaporate.
  - Other special environments.
- Install the unit where enough space of installation and maintenance is available.
- Install the unit where the air inlet and air outlet are free from obstacles and strong wind.
- Install the unit in a dry and well ventilated place.
- Install the unit where the bearing surface is level and can bear weight of the unit, and is suitable for installing the unit horizontally without increasing noise or vibration.
- Install the unit where the operation noise and the expelling of air do not affect neighbours.
- Install the unit where no flammable gas is leaked.
- Install the unit where it is convenient for pipe connection and electric connection.

## 2 OUTDOOR UNIT INSTALLATION

### 2.1 Installation Place

■ The outdoor unit should be installed in the location that meets the following requirements:

- There is enough room for installation and maintenance.
- The air outlet and the air inlet are not impeded, and can not be reached by strong wind.
- It must be a dry and well ventilating place.
- The support is flat and horizontal and can stand the weight of the outdoor unit. And will no additional noise or vibration.
- Your neighborhood will not feel uncomfortable with the noise or expelled air.
- It is easy to install the connecting pipes or cables.
- Determine the air outlet direction where the discharged air is not blocked.
- There is no danger of fire due to leakage of inflammable gas.
- The piping length between the outdoor unit and the indoor unit may not exceed the allowable piping length.
- In the case that the installation place is exposed to strong wind such as a seaside, make sure the fan operating properly by putting the unit lengthwise along the wall or using a dust shield. (Refer to Fig 2.1)
- If possible, do not install the unit where it is exposed to direct sunlight.
- If necessary, install a blind that does not interfere with the air flow.
- During the heating mode, the water drained off the outdoor unit, The condensate should be well drained away by the drain hole to an appropriate place, so as not to interfere other people.
- Select the position where it will not be subject to snow drifts, accumulation of leaves or other seasonal debris. If unavoidable, please cover it with a shelter.
- Locate the outdoor unit as close to the indoor unit as possible.
- If possible, please remove the obstacles nearby to prevent the performance from being impeded by too little of air circulation.
- The minimum distance between the outdoor unit and obstacles described in the installation chart does not mean that the same is applicable to the situation of an airtight room. Leave open two of the three directions (M,N,P) (Refer to Fig.6-5)

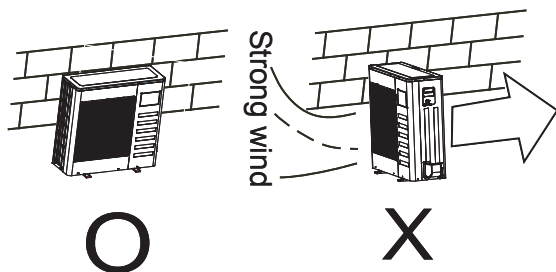

Fig 2.1



#### NOTE

All the figures in this manual are for explanation purpose only. They may be slightly different from the air conditioner you purchased. The actual unit shall prevail.

### 2.2 Figure of body size

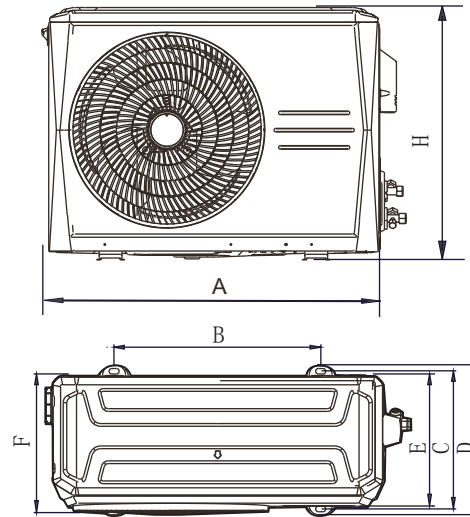

Fig 2.2

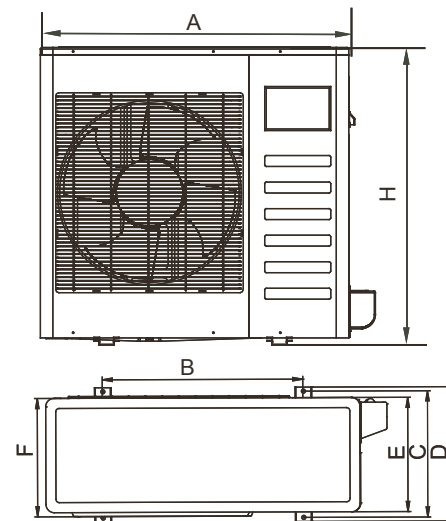

Fig 2.3

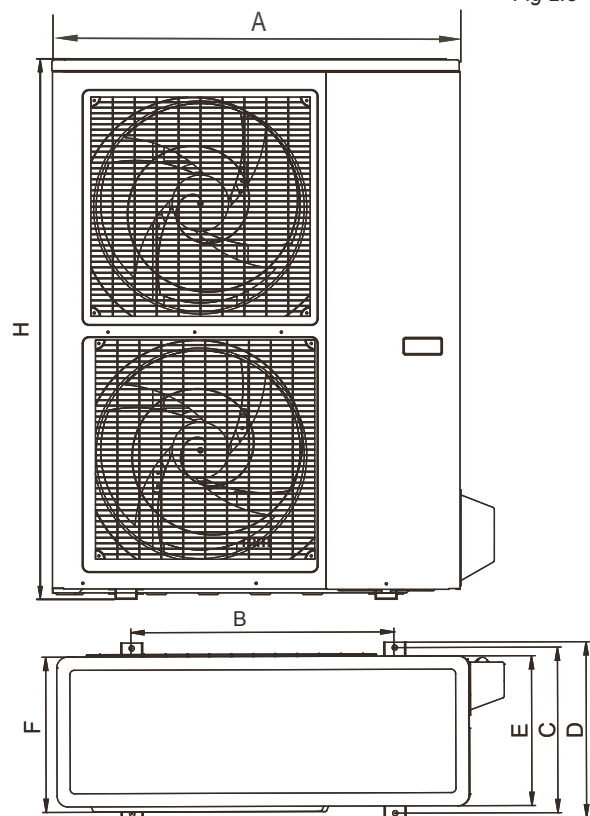

Fig 2.4



Table 2-1

mm

MODEL	A	B	C	D	E	F	H	REMARK
03	722	453	302	327	260	300	555	Fig.2-2
05~07	795	514	340	365	287	330	550	Fig.2-2
10	990	624	366	396	340	345	965	Fig.2-3
14~16	900	590	378	400	330	350	1170	Fig.2-4

(in=mm/25.4)

## 2.3 Space of installation and maintenance

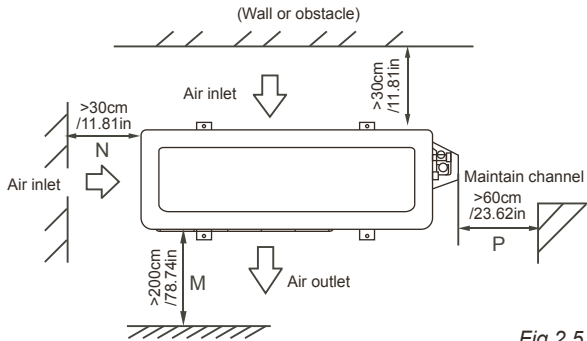

Fig 2.5

## 2.4 Moving and installation

- Since the gravity center of the unit is not at its physical center, so please be careful when lifting it with a sling.
- Never hold the inlet of the outdoor unit to prevent it from deforming.
- Do not touch the fan with hands or other objects.
- Do not lean it more than 45°, and do not lay it sidelong.
- Make concrete foundation according to the specifications of the outdoor units. (Refer to Fig.2-6)
- Fasten the feet of this unit with bolts firmly to prevent it from collapsing in case of earthquake or strong wind. (Refer to Fig.2-6)

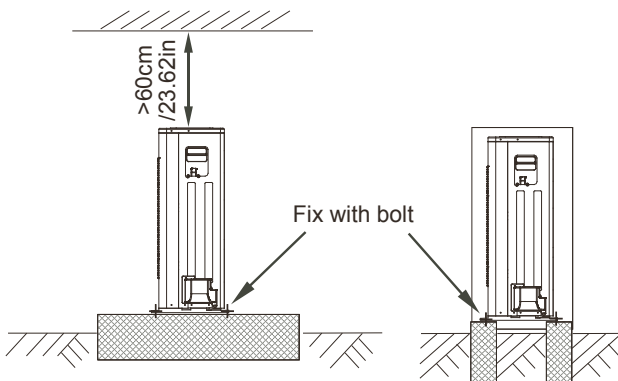

Fig 2.6

## 3 INSTALL THE CONNECTING PIPE

### 3.1 Preparation and Caution

Before installation make sure the height difference, the length of refrigerant pipe, and the number of the bends between the indoor unit and outdoor unit meet the following requirements:

Table 3-1

unit:m

The type of models	Model	The length of refrigerant pipe	The max height drop
R410A Split type air conditioner	03/05/07	20m/65.8ft	10m/32.9ft
	10/14/16	30m/98.7ft	20m/65.8ft

The outdoor unit is charged with rating refrigerant amount in the factory. Additional charge refers to the table below:

Table 3-2

liquid tube(mm)	R410A
Ø6.35	0.022kg/m×(L-5)
Ø9.53	0.060kg/m×(L-5)

- NOTE:the table above refer to the liquid tube.
- NOTE:The number of bends is up to the length of the max height drop.Usually for each 10m/32.9ft need a bend.



### CAUTION

All field piping must be provided by a licensed refrigeration technician and must comply with the relevant local and national codes.

Prevent let air, dust, or other impurities enter in the pipe system during installation.

Insulation pipe shall be used to the gas piping and the liquid piping. Otherwise, the condensate may happen.

### 3.2 The Procedure of Connecting Pipes

#### 1) Measure the required length of the connecting pipe, then make it by the following way.

- Connect the indoor unit first, then the outdoor unit.

- Bend the tubing in proper way. Do not twist the pipe.

Bend the pipe with thumb



min-radius 100mm/3.94in

Fig 3.1

- Put some refrigerant oil on the surfaces of the flare pipe and the joint nuts then wrench it for 3~4 rounds with hands before fasten the flare nuts.

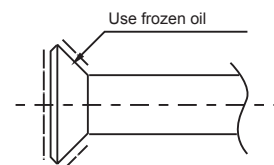

Fig 3.2

- Be sure to use two wrenches simultaneously when you connect or disconnect the pipes.

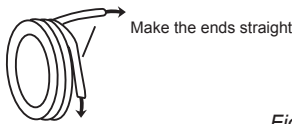

Fig 3.3

- The service valves of the outdoor unit should be completely closed(as original status).Every time to connect,first to loosen nuts, then connect the flare pipes within 5 minutes. If the nuts have been loosened for a long time, dusts and other impurities may enter the pipe system and may cause malfunction.So please expel the air out of the pipe with refrigerant before connection.
- Expel the air after connecting the refrigerant pipe with the indoor unit and the outdoor unit. Then fasten the nuts at the service valves.
- Bend the connecting pipe of small wall thickness.
  - Cut out a proper concave at the bending part of the insulating pipe.
  - Then expose the pipe(cover it with tapes after bending).
  - To prevent twist of deforming, please bend the pipe at a proper radius.



### NOTE

The bending angle should not exceed 90°  
 Bending position is preferably in the middle of the bendable pipe.  
 Do not bend the pipe more than three times.  
 Be sure to use the same insulating materials when you buy the brass pipe. (More than 9mm/0.35in thick)

## 2) Place The Pipe

- Drill a hole in the wall (suitable just for the size of the wall sleeve), then set on the fittings such as the wall sleeve and its cover.
- Bind the connecting pipe and the cables together tightly with binding tapes.
- Pass the bound connecting pipe through the wall sleeve from outside. Make sure of the pipe allocation not to damage the copper tubes.

## 3) Connect the pipes.

## 4) Expel the air with a vacuum pump or refrigerant.

## 5) Open the service valves of the outdoor unit .

## 6) Check the refrigerant leakage. Check all the joints with the leak detector or soap water.

## 7) Cover the joints of the connecting pipe with the insulation foam, and bind them well with the tapes to prevent potential leakage.

# 4 REFRIGERANT PIPE

## 4.1 Size of joint pipes for outdoor unit

Base on the following tables, select the diameters of the outdoor unit connective pipes. In case of the main accessory pipe large than the main pipe, take the large one for the selection.

Table 4-1 Size of joint pipes for 410A outdoor unit

Model	the size of main pipe(mm)	
	Gas side	Liquid side
03/05	Φ12.7/0.501in	Φ6.35/0.25in
07	Φ12.7/0.501in	Φ9.52/0.375in
10	Φ19.0/0.748in	Φ9.52/0.375in
14/16	Φ19.0/0.748in	Φ9.52/0.375in

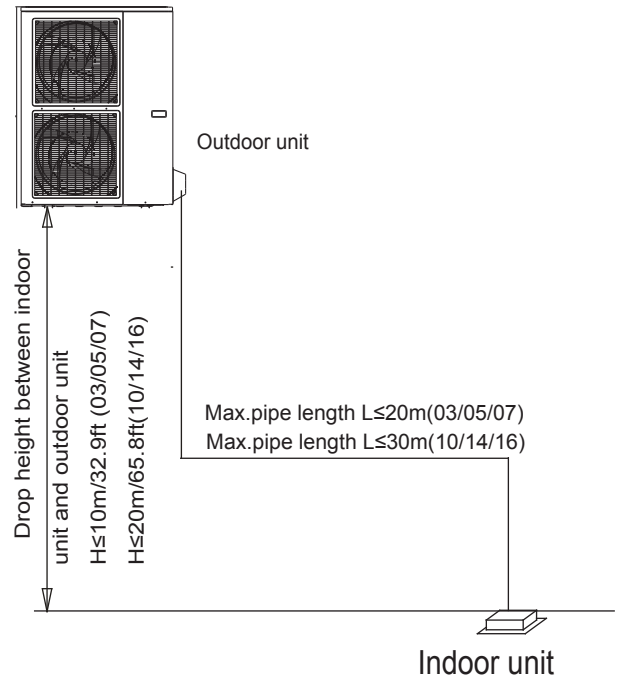

Fig 4.1

# 5 REFRIGERANT PIPE CONNECTION

## 5.1 Expel The Air

### 1) Flaring

- Cut a pipe with a pipe cutter. (Refer to Fig.5-1)

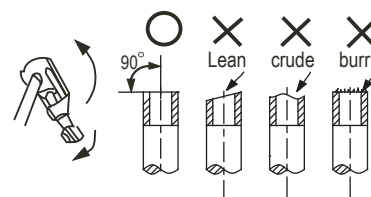

Fig 5.1

- Insert a flare nut into a pipe and flare the pipe.

### 2) Fasten the nut

- Put the connecting pipes at the proper position, wrench the nuts with hands then fasten it with two wrenches simultaneously. (Refer to Fig 5.2)

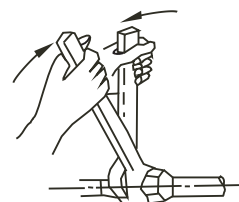

Fig 5.2



## CAUTION

Too large torque will harm the bellmouthing and too small will cause leakage. Please determine the torque according to Table 5-1.

Table 5-1

Pipe gauge	Tightening torque	Flare dimension A		Flare shape
		min (mm)	max	
Ø6.35/0.25in	14.2~17.2 N.m (144~176 kgf.cm)	8.3/0.327in	8.7/0.343in	
Ø9.52/0.375in	32.7~39.9 N.m (333~407 kgf.cm)	12.0/0.472in	12.4/0.488in	
Ø12.7/0.5in	49.5~60.3 N.m (504~616 kgf.cm)	15.4/0.606in	15.8/0.622in	
Ø15.9/0.626in	61.8~75.4 N.m (630~770 kgf.cm)	18.6/0.732in	19.0/0.748in	
Ø19.1/0.725in	97.2~118.6 N.m (990~1210 kgf.cm)	22.9/0.902in	23.3/0.917in	

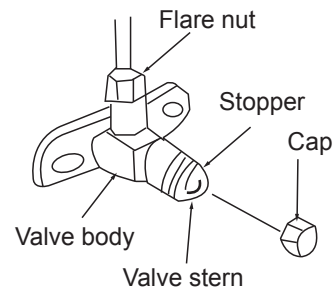

Fig 5.4



## CAUTION

Both service valves should be open before test operation. Each air conditioner has two service valves of different sizes. (Refer to Fig 5.4)

### 3) Expel the air with a vacuum pump

(Please refer to its manual for the way of using manifold valve)

- Loosen and remove the nuts of service valves A and B, and connect the charge hose of the manifold valve with the maintenance terminator of service valve A. (Be sure that service valves A and B are both closed)
- Connect the joint of the charge hose with the vacuum pump.
- Open the Lo-lever of the manifold valve completely.
- Turn on the vacuum pump. At the beginning of pumping, loosen the nut of service valve B a little to check whether the air comes in (the sound of the pump changes, and the indicator of compound meter turns below zero). Then fasten the nut.
- When the pumping has finished, close the Lo-lever of the manifold valve completely and turn off the vacuum pump. When you have pumped for over 15 minutes, please confirm that the indicator of multimeter is on  $-1.0 \times 10^{-5} \text{Pa}$  (-76cmHg)
- Loosen and remove the nuts of service valves A and B to open service valve A and B completely, then fasten nuts.
- Disassemble the charge hose of service valve A, and fasten the nut.

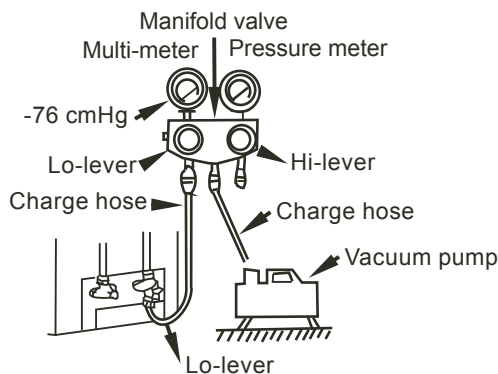

Fig 5.3

## 5.2 Check the Leakage

Check all the joints with the leak detector or soap water. (Refer Fig 5.5 as a reference illustration) in the chart

- A.....Lo-stop valve
- B.....Hi-stop valve
- C,D..Joints of the connecting pipe to the indoor unit.

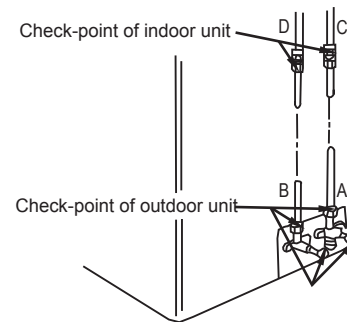

Fig 5.5

## 5.3 Insulation

- Be sure to completely insulate all the exposed parts of the flare pipes.
- Incomplete insulation may cause condensate.

## 6. HEAT INSULATION OF THE PIPE

### 6.1 Heat Insulation Of The Pipe

In order to prevent faults caused by condensate of the refrigerant pipe and drain pipe, perform condensate prevention and heat insulation properly.



## CAUTION

- If it is forecast that high humidity/temperature environment (condensate temperature is over 23°C) may exist in the ceiling, e.g., inside the ceiling with slab, ceiling which is in the same environment as the outdoor air, it is necessary to apply 10mm or thicker adiabatic wool (16~20kg/m<sup>2</sup>) to the refrigerant pipe and the drain pipe in addition to applying the general heat insulation materials. Enough heat insulation materials should also be applied to the refrigerant joint and the pipe joint.

## 6.2 Heat Insulation Of The Refrigerant Pipe

- Please use heat-resistant materials as heat insulation materials of the air-side pipe. (e.g., EPT)
- Cover heat insulation materials separately at the liquid side and the air side. Moreover, perform heat insulation thoroughly for the air-side pipes of the indoor unit, and prevent water from dripping outside the unit.

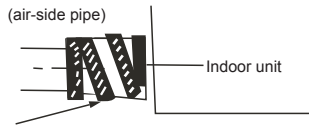

Fig.6-1

- After applying the auxiliary heat insulation materials, use vinylresin tape to seal it lest water leak.

## 7 CONNECTIVE DIAGRAM

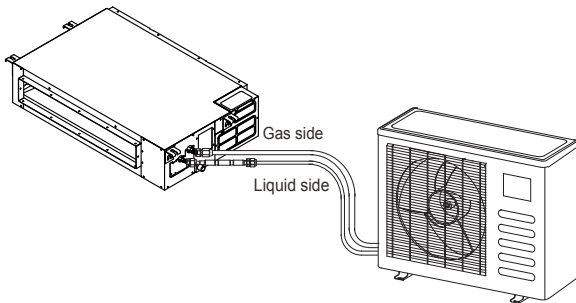

Fig 7.1



### NOTE

For ensuring throttled efficiency, Please mount the Orifice as horizontally as possible; and anti-shock rubber should be wrapped at external of the Orifice for denoise.

## 8 WIRING

The appliance shall be installed in accordance with national wiring regulations.

The air conditioner should use separate power supply with rated voltage.

The external power supply to the air conditioner should be grounded, which is linked to the ground wiring of the indoor and outdoor unit.

The wiring work should be done by qualified persons according to wiring diagram.

A circuit breaker and a residual current device (RCD) with above 10mA rating shall be installed in the power circuit according to the national rule.

Be sure to locate the power wiring and the signal wiring well to avoid cross-disturbance.

Do not turn on the power until you have confirmed proper wiring.

The power cord type is H07RN-F.



### NOTE

Refer to EMC Directive 2004/108/EC

To prevent flicker impressions during the start of the compressor, following installation conditions do apply.

- 1 The power connection for the air conditioner has to be done at the main power distribution. The distribution has to be of a low impedance, normally the required impedance reaches at a 32A fusing point.
- 2 No other equipment has to be connected with this power line.
- 3 For detailed installation acceptance please refer to your power supplier, if restrictions do apply for products like washing machines, air conditioners or electrical ovens.
- 4 For power details of the air conditioner refer to the rating nameplate of the product.
- 5 For any question contact your local dealer.

### 8.1 Connect the cable

- Disassemble the cover.(If there isn't a cover on the outdoor unit, disassemble the screw from the maintenance board, and pull it in the direction of the arrow to remove the protection board.) (Refer to Fig 8.1)
- Connect the cables to the terminals correspondingly.
- Re-install the cover or the protection board.

### 8.2 Wiring figure

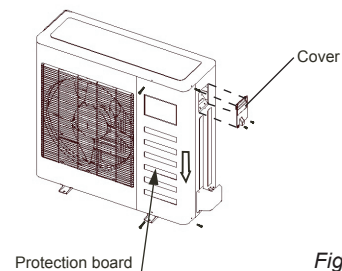

Fig 8.1



### NOTE

All the figures in this manual are for explanation purpose only. They may be slightly different from the air conditioner you purchased(depend on model).The actual unit shall prevail.

# 9 ELECTRIC CONNECTION



## CAUTION

- Use special power supply for the air conditioner. Design power supplies specific to the indoor unit and outdoor unit. The supply voltage must comply with the nominal voltage.
- The external supply circuit of the air conditioner must have a ground wire, and the power supply ground wire of the indoor unit must be connected with the external ground wire firmly.
- The wiring must be performed by professional technicians according to the circuit diagram labels.
- Distribute the wires according to the relevant electric technical standards promulgated by the State, and set the Residual Current-operated Circuit Breaker (RCCB) properly.
- The power wire and the signal wire shall be laid out neatly and properly, without mutual interference or contacting the connection pipe or valve.
- No power cable is attached to this equipment. The user can select the power cable by reference to the stipulated power supply specifications. No joint of wires is allowed.
- Upon completion of wire connection, double check it and then connect the power supply.
- An all-pole disconnection device which has at least 3mm separation distance in all pole and a residual current device(RCD)with the rating of above 10mA shall be incorporated in the fixed wiring according to the national rule.
- The appliance shall be installed in accordance with national wiring regulations.

### Specifications of power supply

Model	Power	Switch capacity of the main power supply/fuse(A)	Outdoor unit power cable includes grounded wire	Connective wire of indoor outside unit
MCCU-03CN1A	220-240V~ 50Hz	20/16	RVV-300/500 2X2.5+1X1.5 mm <sup>2</sup>	-
MCCU-05CN1A		30/20	RVV-300/500 2X4.0+1X2.5 mm <sup>2</sup>	
MCCU-07CN1A		40/30	RVV-300/500 2X6.0+1X4.0 mm <sup>2</sup>	
MCCU-10CN1	380-415V 3N~ 50Hz	25/20	RVV-300/500 4X4.0+1X2.5 mm <sup>2</sup>	RVV-300/500 1X1.0 mm <sup>2</sup>
MCCU-14CN1		25/20	RVV-300/500 4X4.0+1X2.5 mm <sup>2</sup>	
MCCU-16CN1		45/35	RVV-300/500 4X10.0+1X6.0 mm <sup>2</sup>	

### Power wires

The power wires are as follows: (schematic diagram)

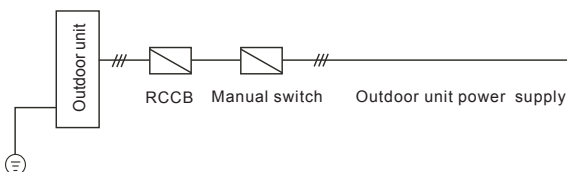

Fig 9.1

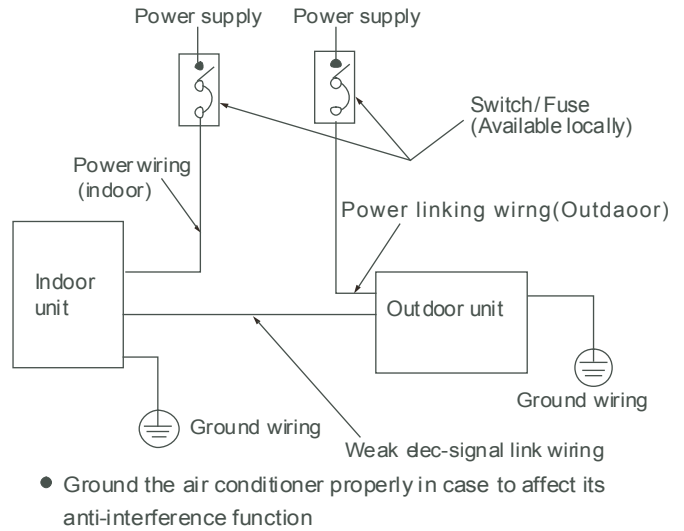

Fig 9.2



## NOTE

Please identify outdoor main unit and auxiliary unit. Only main unit connects with signal wire of indoor unit. Users should adjust the dial on electric control board of outdoor unit as follows, otherwise incorrect adjustment may cause malfunction.

# 10 ELECTRIC WIRE DIAGRAM

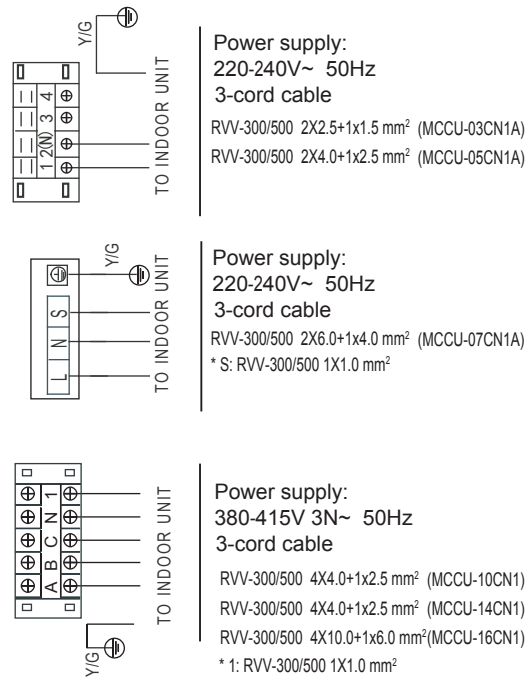

Fig 10.1



## NOTE

- Pay attention to the phase sequence of the power supply. If the phase sequence is reversed, the compressor will not start. Meanwhile, the fault indicator of the outdoor electric control board will light up. For details, see Outdoor unit wiring diagram on the cover plate of the electric control box.
- After shifting the phase sequence, power on the unit until the fault indicator goes out and the compressor starts up normally.

# 11 TRIAL RUN

Please conduct in accordance with "Trial Run Tenor Nameplate" on the electric control box.



## CAUTION

- Perform the trial run only after the outdoor unit has been powered on for over 12 hours.
  - Check that all valves are opened before trial run.
  - Check the electric safety before trial run.
  - Do not perform compulsory operation in any way.(It is very dangerous if the protection device is not active)
- 
- Perform trial run only after all installations are finished.
  - Confirm the following issues before trial operation, and ✓ the box for the confirmed items.
    - Check whether the indoor unit and the outdoor are installed properly.
    - Check whether the piping and wiring are correct.
    - Check whether the refrigerant pipeline system is inspected for leakage.
    - Check whether the drain is smooth.
    - Check whether the heat insulation is perfect.
    - Check whether the ground cables are connected correctly.
    - Check whether the pipe length and the refrigerant amount are recorded.
    - Check whether the supply voltage is equal to the rated voltage of the air conditioner.
    - Check whether any obstacles exist at the air inlet/outlet of the indoor or outdoor unit.
    - Open the gas valve and the liquid valve.
    - Connect the power supply to preheat the air conditioner.

## Air flow of the indoor unit

Table 11-2

Model	Air flow of the indoor unit
MCCU-03CN1A	500~650m <sup>3</sup> /h
MCCU-05CN1A	700~900m <sup>3</sup> /h
MCCU-07CN1A	1000~1250m <sup>3</sup> /h

## Safety precautions

The electric circuit must be installed RCCB and manual switch

Table 11-1

Cooling operation	Outdoor temperature:17~46°C
	Indoor temperature:≥17°C
Dewetting operation	Outdoor temperature:17~46°C
	Indoor temperature:17~32°C







本页不打印

规格：A4

材质：100g双胶纸

更改记录