



Air-cooled package Middle Static Pressure Duct unit High Static Pressure Duct unit Service Manual 2013

MTA-76CRN1 / MOV-76CN1-C
MTA-96CRN1 / MOV-96CN1-C
MTA-120CRN1 / MOV-120CN1-C
MTA-150CRN1 / 2* MOV-76CN1-C
MTA-76HRN1 / MOV-76HN1-C
MTA-96HRN1 / MOV-96HN1-C
MTA-120HRN1 / MOV-120HN1-C

MHB-76CRN1 / MOV-76CN1-C
MHB-96CRN1 / MOV-96CN1-C
MHB-76HRN1 / MOV-76HN1-C
MHB-96HRN1 / MOV-96HN1-C



Content

Part 1	General Information	2
Part 2	Indoor Units	6
Part 3	Outdoor Units	44
Part 4	Installation	59
Part 5	Control	92

Part 1 General Information

1. Model Names of Indoor/Outdoor Units	3
2. External Appearance	4
3. Nomenclature.....	5

1. Model Names of Indoor/Outdoor Units

1.1 Model Names of Units with Cooling only:



Type	Indoor unit		Outdoor unit		Capacity	
	Model	Power supply	Model	Power supply	kW	Btu/h
Mid-static pressure duct type	MTA-76CRN1	220~240V-1 Ph-50Hz	MOV-76CN1-C	380~415V-3 N-50Hz	22	76
	MTA-96CRN1		MOV-96CN1-C		28	96
	MTA-120CRN1		MOV-120CN1-C	380~400V-3 N-50Hz	35	120
	MTA-150CRN1		MOV-76CN1-C *2		44	150
High-static pressure duct type	MHB-76CRN1		MOV-76CN1-C	380~415V-3 N-50Hz	22	76
	MHB-96CRN1		MOV-96CN1-C		28	96

1.2 Model Names of Units with Cooling and heating:

Type	Indoor unit		Outdoor unit		Capacity	
	Model	Power supply	Model	Power supply	kW	Btu/h
Mid-static pressure duct type	MTA-76HRN1	220~240V-1 Ph-50Hz	MOV-76HN1-C	380~415V-3 N-50Hz	22	76
	MTA-96HRN1		MOV-96HN1-C		28	96
	MTA-120HRN1		MOV-120HN1-C	380~400V-3 N-50Hz	35	120
	MTA-150HRN1		MOV-76HN1-C *2		44	150
High-static pressure duct type	MHB-76HRN1		MOV-76HN1-C	380~415V-3 N-50Hz	22	76
	MHB-96HRN1		MOV-96HN1-C		28	96

2. External Appearance

2.1 Indoor Units

<p>MTA-76C(H)RN1 MTA-96C(H)RN1</p>	<p>MTA-120CRN1 \ MTA-120HRN1 MTA-150CRN1</p>
	

2.2 Outdoor Unit

<p>MOV-76C(H)N1-C MOV-96C(H)N1-C MOV-150C(H)N1-C (MOV-76C(H)N1-C*2)</p>	<p>MOV-120C(H)N1-C</p>
	

3. Nomenclature

3.1 Indoor unit:

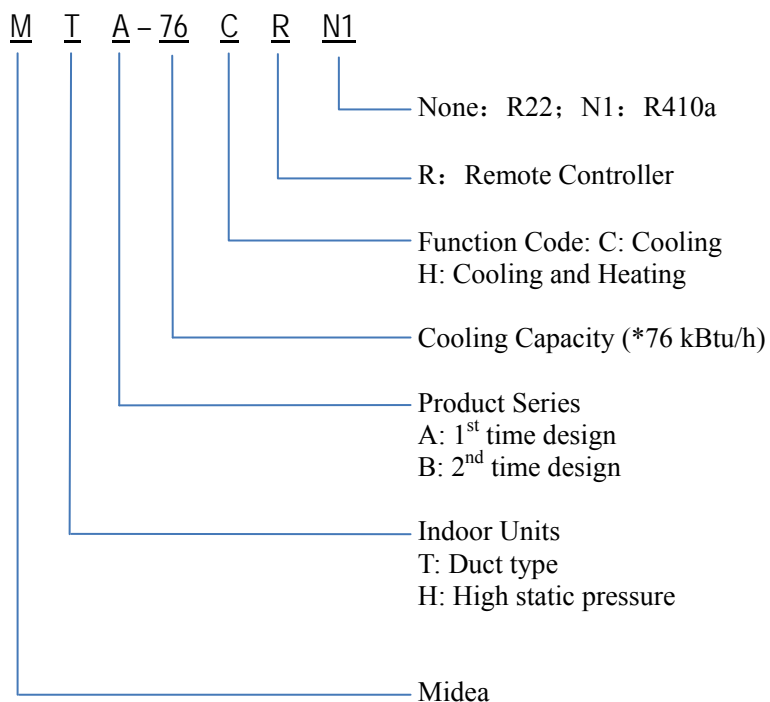

3.2 Outdoor unit:

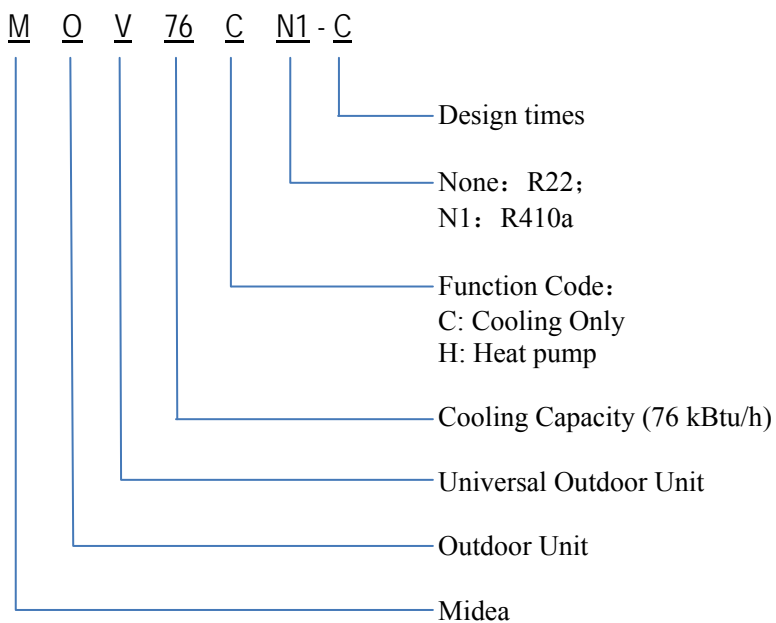

Part 2 Indoor Units

1. Features	7
2. Specifications	8
3. Dimensions	11
4. Service Space	12
5. Piping Diagrams	14
6. Wiring Diagrams	14
7.Capacity Table	19
8. Static Pressure	33
9. Electric Characteristics	35
10. Sound Levels	36
11. Troubleshooting	37

1. Features

1. Nested in the ceiling, space-saving and noble.
2. High capacity of cooling/heating, efficient, and energy-saving.
3. The air outlet is laid out according to you desire.
4. Economic and convenient installation
 - 1) Several diffusers branch off from an indoor unit, adjusting the room temperature, which makes many rooms to be air-conditioned with only one indoor unit.
 - 2) All models feature thin design making them applicable to ceiling pocket that tends to be shallow
5. Way of air intake and inserting air filter

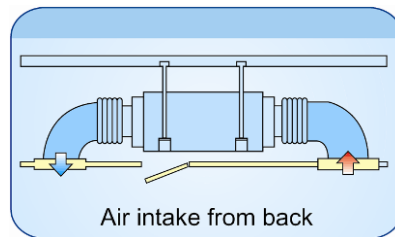

6. It is suitable to be used for office, hospital, commercial place and home, the air conditioner will create the comfortable and elegant environment for you.

2. Specifications

Model			MTA-76CRN1	MTA-76HRN1	MTA-96CRN1	MTA-96HRN1
Power supply		-	220~240V-1Ph-50Hz		220~240V-1Ph-50Hz	
Temp. setting range		℃	≥17	≤30	≥17	≤30
Rated input power		W	11700	11700	14400	14400
Rated current		A	19.3	19.3	23.7	23.7
Cooling	Capacity	Btu/h	76000	76000	96000	96000
		W	22000	22000	28000	28000
	Input	W	7500	7500	9600	9600
	EER	W/W	2.93	2.93	2.92	2.92
Heating	Capacity	Btu/h	/	78000	/	105000
		W	/	25000	/	31000
	Input	W	/	8300	/	10300
	COP	W/W	/	3.01	/	3.01
Indoor air flow		m ³ /h	4250	4250	5100	5100
Indoor standard ESP		Pa	100	100	100(98)	100(98)
Indoor noise level		dB(A)	54	54	55	55
Refrigerant	Type	-	R410A	R410A	R410A	R410A
	Control	-	Capillary		Capillary	
Fan	Type	-	Centrifugal fan	Centrifugal fan	Centrifugal fan	Centrifugal fan
	Dimension	mm	Φ307	Φ307	Φ307	Φ307
	Drive type/ Motor step	-	Direct/ Single	Direct/ Single	Direct/ Single	Direct/ Single
	Motor input* No.	W	446*2	446*2	725*2	725*2
	Motor speed	rpm	877	877	1136	1136
Coil	Type	-	Copper tube and aluminum fin		Copper tube and aluminum fin	
	Tube size	mm	Φ9.52	Φ9.52	Φ9.52	Φ9.52
	No. of rows	-	3	3	4	4
	Fin per inch	FPI	17	17	17	17
	Length* height	mm	1200*406.4	1200*406.4	1200*406	1200*406
Controller		-	Remote controller		Remote controller	
Drain pipe size		mm	41	41	41	41
Dimension (W*H*D)		mm	1350*760*450	1350*760*450	1350*760*450	1350*760*450
Packing (W*H*D)		mm	1549*476*917	1549*476*917	1549*917*476	1549*917*476
Net/Gross weight		kg	105/120	105/120	105/120	105/120
Shipping Qty.(20'/40'/40'HQ)		pcs.	30/64/64	30/64/64	30/64/64	30/64/64

Notes:

- ESP: external static pressure
- Nominal cooling capacities are based on the following conditions:
Indoor temp: 27°CDB, 19°CWB; Outdoor temp: 35°CDB, 24°CWB; Equivalent refrigerant piping: 7.5m (horizontal).
- Nominal heating capacities are based on the following conditions:
Indoor temp: 20°CDB, 15°CWB; Outdoor temp: 7°CDB, 6°CWB; Equivalent refrigerant piping: 7.5m (horizontal).

Model			MTA-120CRN1	MTA-120HRN1	MTA-150CRN1	MTA-150CRN1
Power supply	-		220~240V-1Ph-50Hz		220~240V-1Ph-50Hz	
Temp. setting range	℃		≥17	≤30	≥17	≤30
Rated input power	W		17300	17300	21200	21200
Rated current	A		28.6	28.6	35	35
Cooling	Capacity	Btu/h	120000	120000	150000	150000
		W	35000	35000	44000	44000
	Input	W	12000	12000	15100	15100
	EER	W/W	2.92	2.92	2.91	2.91
Heating	Capacity	Btu/h	/	120000	/	160000
		W	/	38000	/	47000
	Input	W	/	12600	/	15700
	COP	W/W	/	3.02	/	3
Indoor air flow	m ³ /h		6375	6375	7650	7650
Indoor standard ESP	Pa		150	150	150	150
Indoor noise level	dB(A)		56	56	56	56
Refrigerant	Type	-	R410A	R410A	R410A	R410A
	Control	-	Capillary		Capillary	
Fan	Type	-	Centrifugal fan	Centrifugal fan	Centrifugal fan	Centrifugal fan
	Dimension	mm	Φ307	Φ307	Φ307	Φ307
	Drive type/ Motor step	-	Direct/ Single	Direct/ Single	Direct/ Single	Direct/ Single
	Motor input * No.	W	498*3	498*3	630*3	630*3
	Motor speed	rpm	860	860	1202	1202
Coil	Type	-	Copper tube and aluminum fin		Copper tube and aluminum fin	
	Tube size	mm	Φ7	Φ7	Φ7	Φ7
	No. of rows		4	4	4	4
	Fin per inch	FPI	17	17	17	17
	Length* height	mm	1602*588	1602*588	1602*588	1602*588
Controller	-		Remote controller		Remote controller	
Drain pipe size	mm		41	41	41	41
Dimension (W*H*D)	mm		1828*858*638	1828*858*638	1828*858*638	1828*858*638
Packing (W*H*D)	mm		2095*929*689	2095*929*689	2095*929*689	2095*929*689
Net/Gross weight	kg		188/220	188/220	188/200	188/200
Shipping Qty per (20'/40'/40'HD)	pcs		19/42/46	19/42/46	19/42/46	19/42/46

Notes:

1. ESP: external static pressure
2. Nominal cooling capacities are based on the following conditions:
Indoor temp: 27°CDB, 19°CWB; Outdoor temp: 35°CDB, 24°CWB; Equivalent refrigerant piping: 7.5m (horizontal).
3. Nominal heating capacities are based on the following conditions:
Indoor temp: 20°CDB, 15°CWB; Outdoor temp: 7°CDB, 6°CWB; Equivalent refrigerant piping: 7.5m (horizontal).

Model			MHB-76CRN1	MHB-76HRN1	MHB-96CRN1	MHB-96HRN1
Power supply		-	220~240V-1Ph-50Hz		220~240V-1Ph-50Hz	
Temp. setting range		°C	≥17	≤30	≥17	≤30
Rated input power		W	11700	11700	14400	14400
Rated current		A	19.3	19.3	23.7	23.7
Cooling	Capacity	Btu/h	76000	76000	96000	96000
		W	22000	22000	28000	28000
	Input power	W	7500	7500	9600	9600
	EER	W/W	2.93	2.93	2.92	2.92
Heating	Capacity	Btu/h	/	78000	/	95500
		w	/	25000	/	31000
	Input power	W	/	8300	/	10300
	COP	W/W	/	3.01	/	3.01
Indoor air flow		m ³ /h	4250	4250	5100	5100
Indoor standard ESP		Pa	196	196	196	196
Indoor noise level		dB(A)	58	58	60	60
Refrigerant	Type	-	R410A	R410A	R410A	R410A
	Control	-	Capillary		Capillary	
Fan	Type	-	Centrifugal fan	Centrifugal fan	Centrifugal fan	Centrifugal fan
	Dimension	mm	Φ307	Φ307	Φ307	Φ307
	Drive type/ Motor step	-	Direct/ Single	Direct/ Single	Direct/ Single	Direct/ Single
	Motor input* No.	W	663*2	663*2	788*2	788*2
	Motor speed	rpm	1022/871/758	1022/871/758	1135/983/845	1135/983/845
Coil	Type	-	Copper tube and aluminum fin		Copper tube and aluminum fin	
	Tube size	mm	Φ9.52	Φ9.52	Φ9.52	Φ9.52
	No. of rows	-	3	3	4	4
	Fin per inch	FPI	17	17	17	17
	Length*Height	mm	1200*406.4	1200*406.4	1200*406	1200*406
Controller		-	Remote controller		Remote controller	
Drain pipe size		mm	41	41	41	41
Dimension (W*H*D)		mm	1350*760*450	1350*760*450	1350*760*450	1350*760*450
Packing (W*H*D)		mm	1549*476*917	1549*476*917	1549*917*476	1549*917*476
Net/Gross weight		kg	105/120	105/120	105/120	105/120
Shipping Qty per (20'/40'/40'HD)		pcs	30/64/64	30/64/64	30/64/64	30/64/64

Notes:

1. ESP: external static pressure
2. Nominal cooling capacities are based on the following conditions:
Indoor temp: 27°CDB, 19°CWB; Outdoor temp: 35°CDB, 24°CWB; Equivalent refrigerant piping: 7.5m (horizontal).
3. Nominal heating capacities are based on the following conditions:
Indoor temp: 20°CDB, 15°CWB; Outdoor temp: 7°CDB, 6°CWB; Equivalent refrigerant piping: 7.5m (horizontal).

3. Dimensions

3.1 Duct type units with two air outlets:

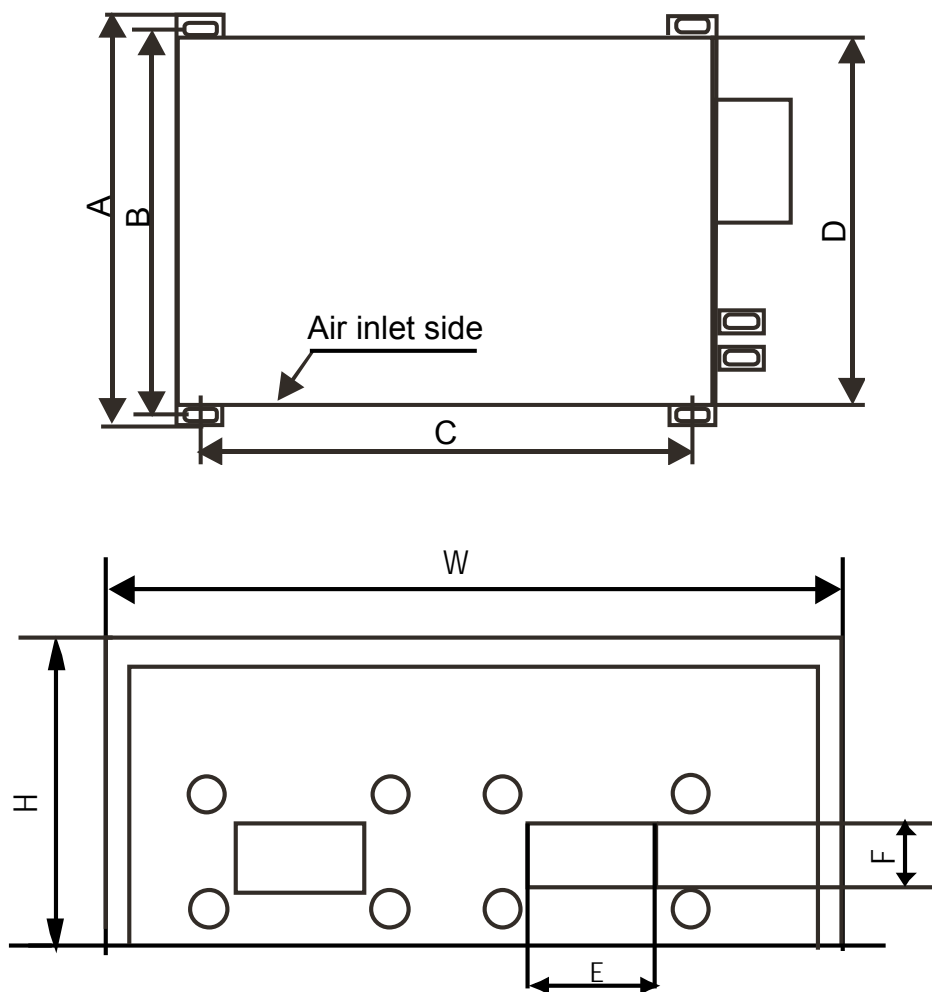

Model	A (mm)	B (mm)	C(mm)	E(mm)	F(mm)	W (mm)	H (mm)	D (mm)
MTA-76CRN1	840	800	1180	300	165	1350	450	760
MTA-76HRN1								
MTA-96CRN1	840	800	1180	300	165	1350	450	760
MTA-96HRN1								
MHB-76CRN1	840	800	1180	300	165	1350	450	760
MHB-76HRN1								
MHB-96CRN1	840	800	1180	300	165	1350	450	760
MTA-96HRN1								

3.2 Duct type units with three air outlets:

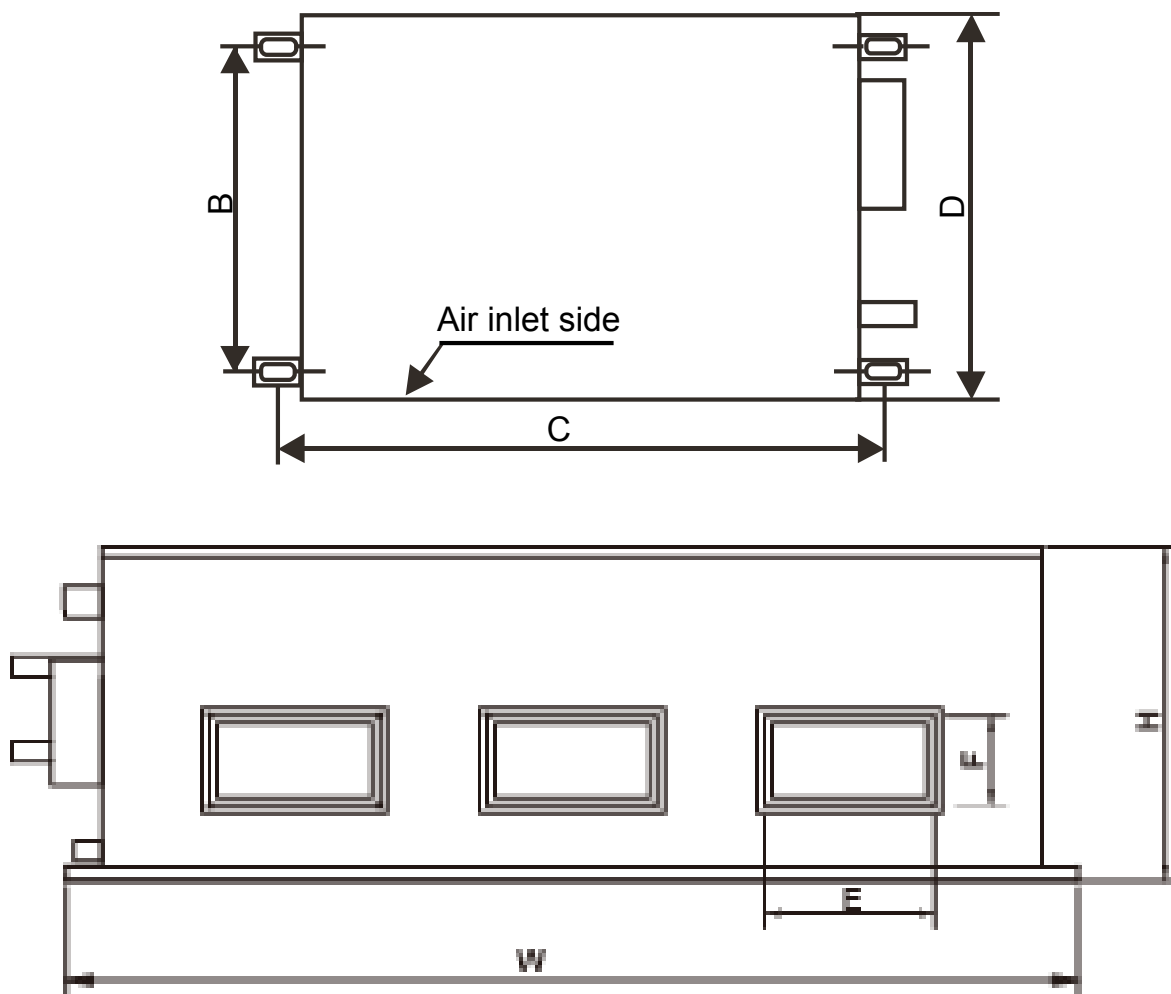

Model	B (mm)	C(mm)	E(mm)	F(mm)	W (mm)	H (mm)	D (mm)
MTA-120CRN1	794.5	1895	330	180	1970	668	860
MTA-120HRN1							
MTA-150CRN1	794.5	1895	330	180	1970	668	860

4. Service Space

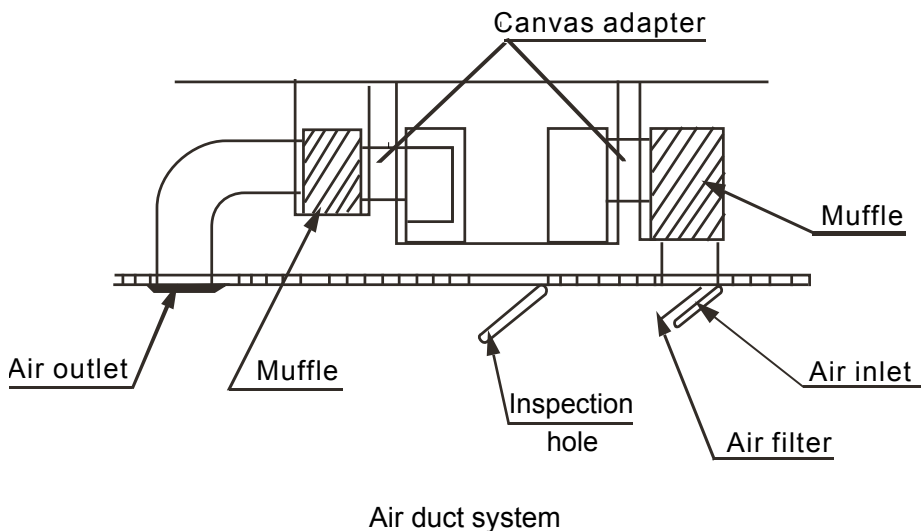
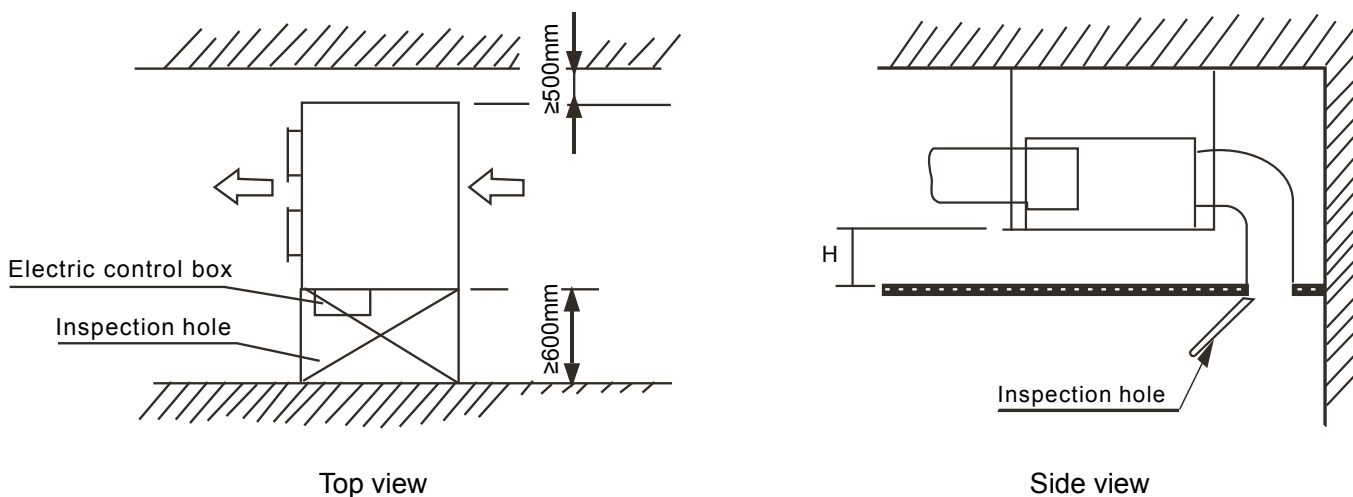

5. Refrigerant cycle diagram

5.1 Cooling only: MTA-76CRN1, MTA-96CRN1, MTA-120CR N1, MTA-150CR N1 MHB-76CRN1, MHB-96CRN1

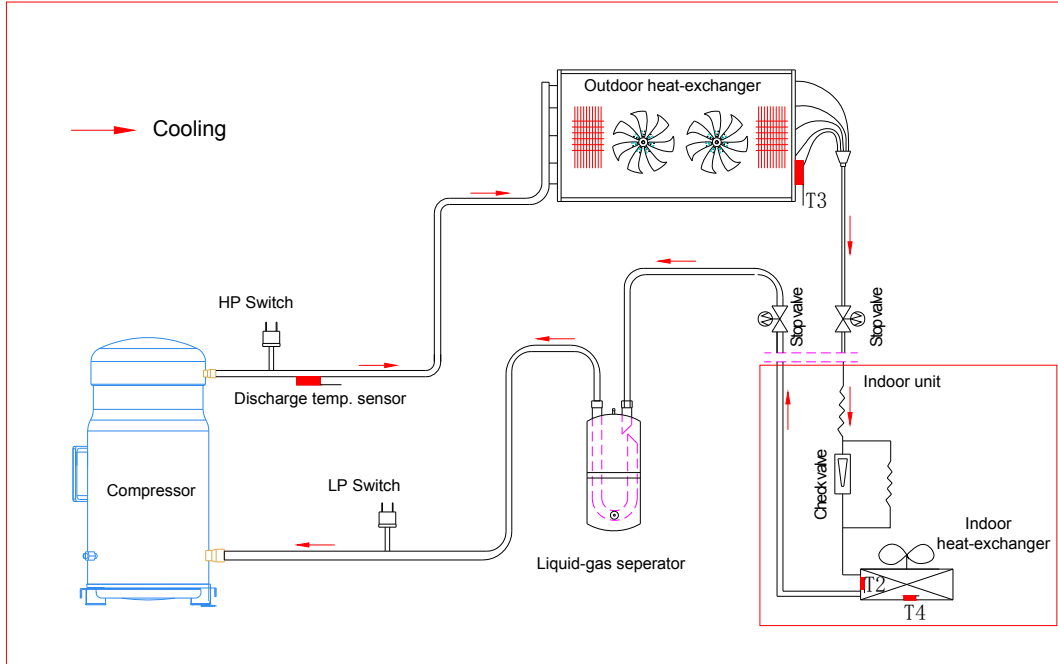

5.2 Cooling and heating: MTA-76HRN1, MTA-96HRN1, MTA-120HRN1 MHB-76HRN1, MHB-96HRN1

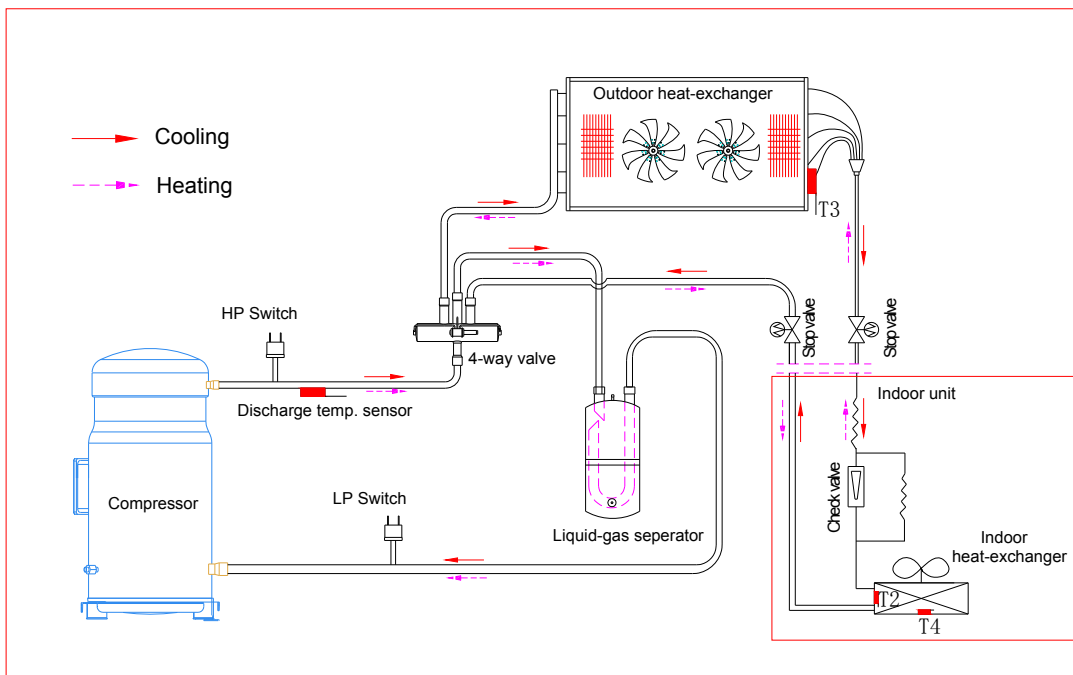

6. Wiring Diagrams

6.1 MTA-76CRN1, MTA-96CRN1, MHB-76CRN1, MHB-96CRN1

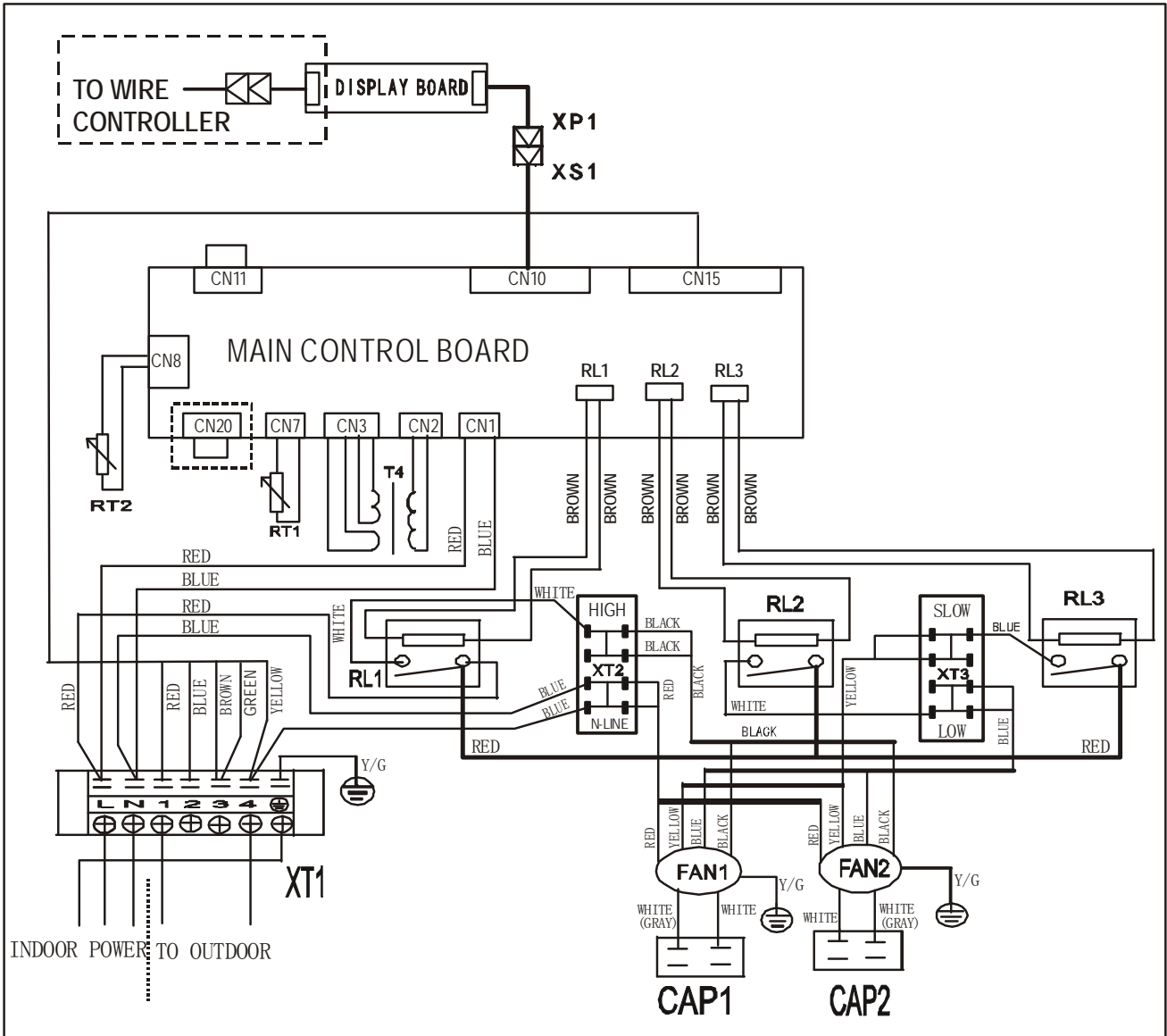

Item	Name	Item	Name	Item	Name
CAP1-CAP2	Indoor fan cap	CN1-3,CN7,CN8, CN10, CN11,CN15,CN20	PCB sockets	T4	Transformer
FAN1-FAN2	Indoor fan	RT1	Room temp. sensor	RT2	Pipe temp. sensor
XP1	Connector	XS1	Connector	XT1	7-way terminal
XT2,XT3	Mid terminal	RL1,RL2,RL3	Relay	-	-

MTA-120CRN1, MTA-150CRN1

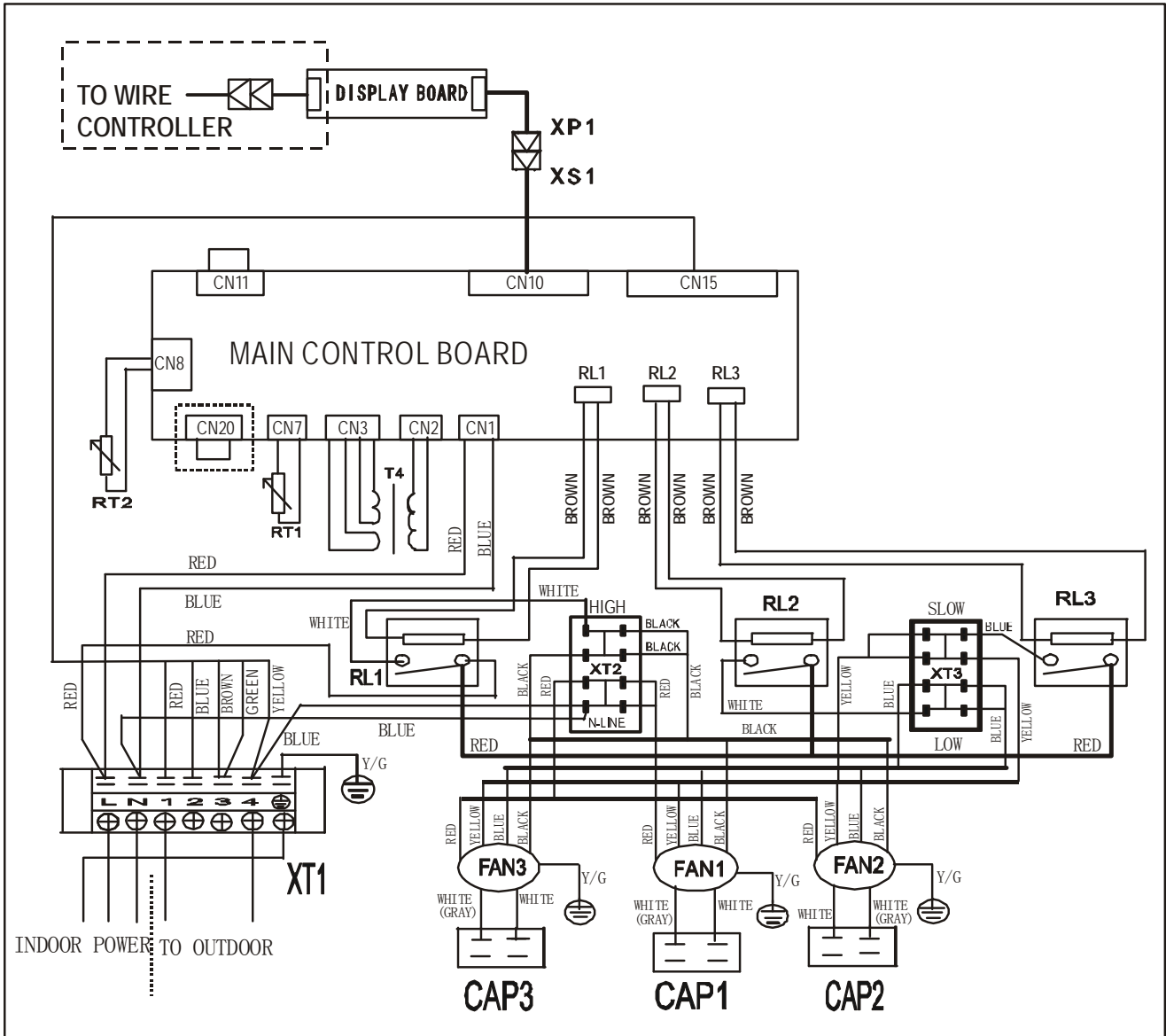

Item	Name	Item	Name	Item	Name
CAP1-CAP3	Indoor fan cap	CN1-3,CN7,CN8, CN10,CN11,CN15,CN20	PCB sockets	T4	Transformer
FAN1-FAN3	Indoor fan	RT1	Room temp. sensor	RT2	Pipe temp. sensor
XP1	Connector	XS1	Connector	XT1	7-way terminal
XT2,XT3	Mid terminal	RL1,RL2,RL3	Relay	-	-

6.2 MTA-76HRN1, MTA-96HRN1, MHB-76HRN1, MHB-96HRN1

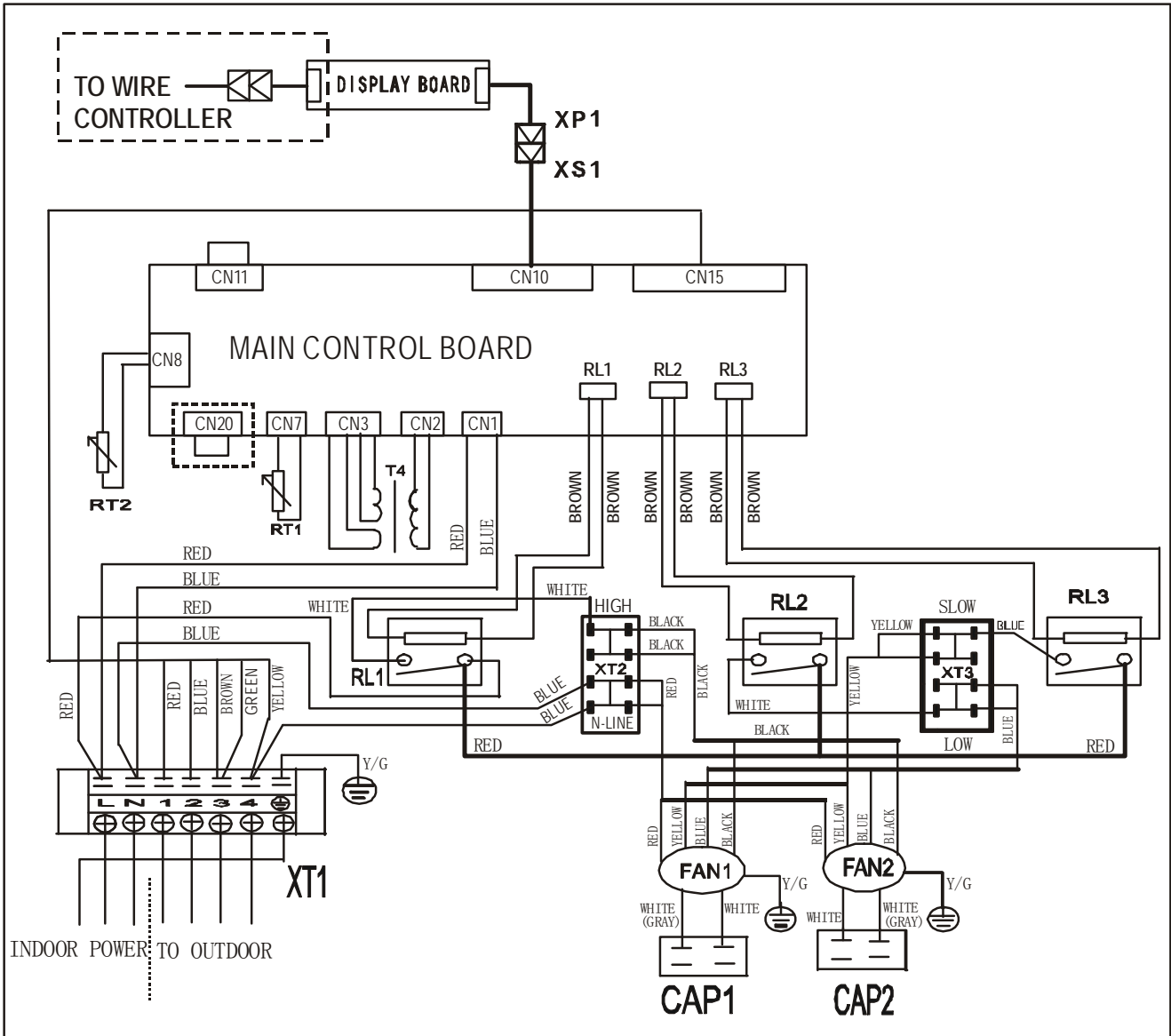

Item	Name	Item	Name	Item	Name
CAP1-CAP2	Indoor fan cap	CN1-3,CN7,CN8, CN10,CN11,CN15,CN20	PCB sockets	T4	Transformer
FAN1-FAN2	Indoor fan	RT1	Room temp. sensor	RT2	Pipe temp. sensor
XP1	Connector	XS1	Connector	XT1	7-way terminal
XT2,XT3	Mid terminal	RL1,RL2,RL3	Relay	-	-

MTA-120HRN1

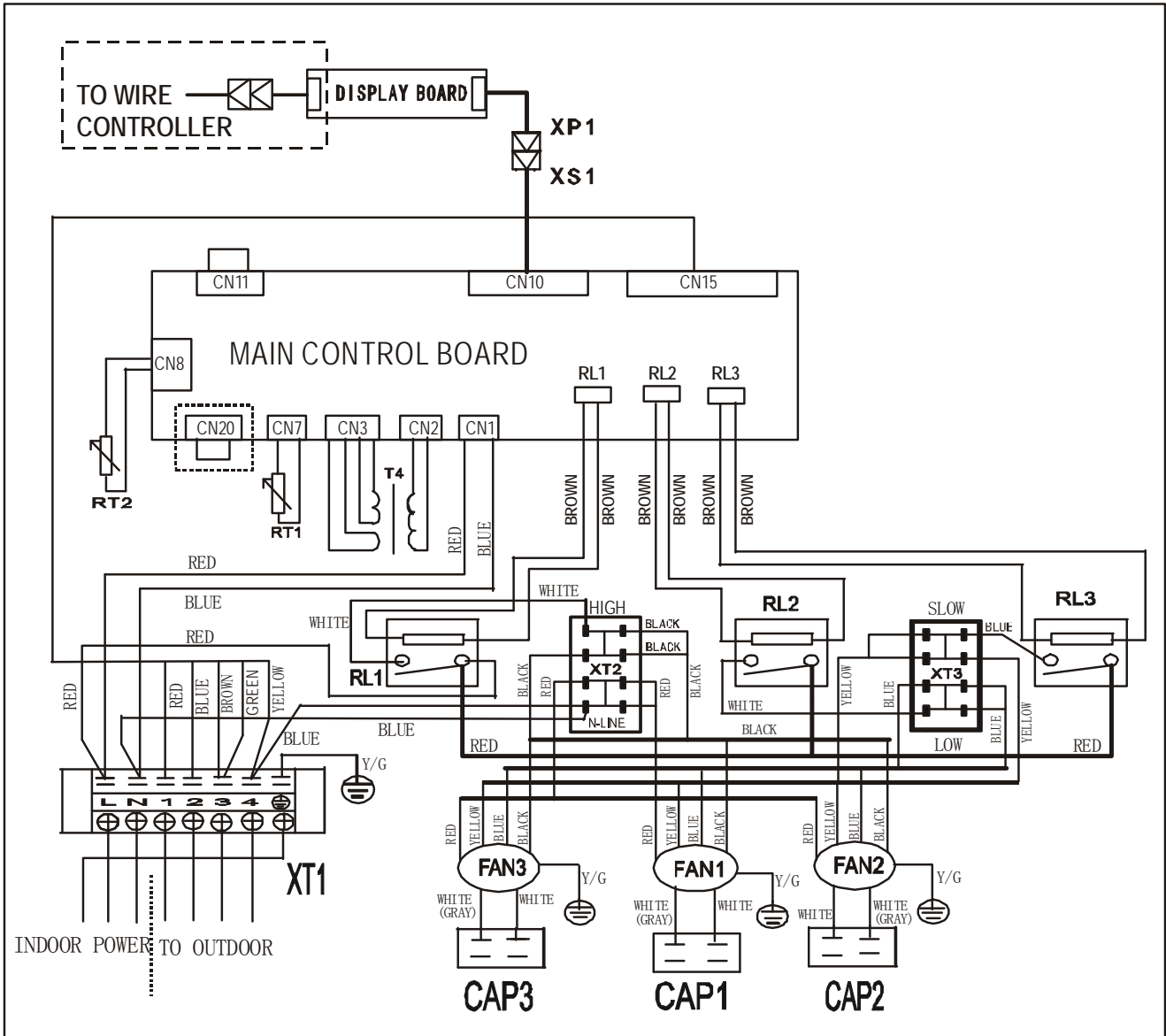

Item	Name	Item	Name	Item	Name
CAP1-CAP3	Indoor fan cap	CN1-3,CN7,CN8, CN10,CN11,CN15,CN20	PCB sockets	T4	Transformer
FAN1-FAN3	Indoor fan	RT1	Room temp. sensor	RT2	Pipe temp. sensor
XP1	Connector	XS1	Connector	XT1	7-way terminal
XT2,XT3	Mid terminal	RL1,RL2,RL3	Relay	-	-

7. Capacity Table

7.1 Cooling:

7.1.1 MTA-76CRN1

Gross Cooling Capacity(kW)																			
Outdoor DB(°C)		29.40									35.00								
Indoor	WB (°C)	16.10			19.40			22.80			16.10			19.40			22.80		
CFM	DB(°C)	TGC	SHC	PI	TGC	SHC	PI	TGC	SHC	PI	TGC	SHC	PI	TGC	SHC	PI	TGC	SHC	PI
2000	23.9	19.5	15.2	6.56	21.9	12.4	6.76	23.3	5.4	6.89	18.7	15.3	6.99	20.8	11.7	7.22	22.0	5.1	7.36
	26.7	20.2	17.4	6.58	22.4	14.5	6.78	23.8	10.3	6.91	19.1	17.4	7.01	21.2	13.7	7.24	22.5	9.7	7.38
	29.4	20.9	19.0	6.60	22.8	18.7	6.80	24.3	14.4	6.93	19.5	18.7	7.03	21.6	17.7	7.26	22.9	13.6	7.40
	32.2	21.6	21.2	6.61	23.3	21.2	6.81	24.7	18.2	6.94	19.9	19.5	7.05	22.0	20.0	7.28	23.4	17.2	7.42
2300	23.9	20.6	16.5	6.76	22.5	13.0	6.96	23.9	5.6	7.09	19.7	16.6	7.19	21.4	12.4	7.42	22.6	5.3	7.56
	26.7	21.3	18.5	6.78	23.0	16.3	6.98	24.4	10.7	7.11	20.1	18.6	7.21	21.8	15.5	7.44	23.1	10.1	7.58
	29.4	22.0	20.4	6.80	23.5	19.7	7.00	24.9	15.2	7.13	20.5	20.1	7.23	22.2	18.7	7.46	23.6	14.4	7.60
	32.2	22.8	21.7	6.81	23.9	22.2	7.01	25.4	18.9	7.15	20.9	20.9	7.25	22.7	21.0	7.47	24.0	17.9	7.62
2500	23.9	21.1	18.3	7.00	23.0	14.4	7.33	24.4	6.3	7.33	20.2	18.5	7.43	21.9	13.7	7.48	23.1	6.0	7.80
	26.7	21.8	20.8	7.02	23.5	18.1	7.22	24.9	11.9	7.35	20.6	20.6	7.45	22.0	17.2	7.50	23.6	11.3	7.82
	29.4	22.6	21.9	7.04	24.0	22.0	7.24	25.4	16.8	7.37	21.0	21.0	7.47	22.7	20.9	7.70	24.1	15.9	7.84
	32.2	23.4	22.9	7.06	24.4	22.2	7.26	25.9	21.1	7.39	21.4	21.4	7.49	23.2	21.1	7.72	24.6	20.0	7.86
2800	23.9	21.5	19.1	7.31	23.5	14.1	7.51	24.9	6.1	7.64	21.0	18.6	7.74	22.4	13.4	7.97	23.6	5.8	8.11
	26.7	22.3	21.4	7.33	24.0	17.6	7.53	25.4	11.5	7.66	21.4	20.6	7.76	22.8	16.8	7.99	24.1	11.0	8.13
	29.4	23.1	22.4	7.35	24.5	21.3	7.55	25.9	16.4	7.68	21.8	21.8	7.78	23.3	20.2	8.01	24.6	15.6	8.15
	32.2	23.9	23.4	7.37	25.0	24.0	7.57	26.4	20.5	7.70	22.3	22.3	7.80	23.7	22.8	8.03	25.1	19.4	8.17

Gross Cooling Capacity (kW)																												
Outdoor DB(°C)		40.60									46.10									51.70								
Indoor	WB(°C)	16.10			19.40			22.80			16.10			19.40			22.80			16.10			19.40			22.80		
CFM	DB(°C)	TGC	SHC	PI	TGC	SHC	PI	TGC	SHC	PI	TGC	SHC	PI	TGC	SHC	PI	TGC	SHC	PI	TGC	SHC	PI	TGC	SHC	PI	TGC	SHC	PI
2000	23.9	17.3	14.2	7.94	18.9	10.7	8.18	20.1	4.6	8.33	15.8	13.0	8.13	17.3	9.8	8.39	18.5	4.3	8.64	15.5	12.7	8.51	16.8	9.5	8.87	17.9	4.1	9.12
	26.7	17.6	16.0	7.96	19.2	12.5	8.20	20.5	8.8	8.35	16.1	14.7	8.15	17.6	11.4	8.41	18.8	8.1	8.66	15.8	14.4	8.53	17.1	11.1	8.89	18.2	7.9	9.14
	29.4	18.0	17.3	7.98	19.6	16.1	8.22	20.9	12.5	8.37	16.5	15.8	8.17	18.0	14.7	8.43	19.2	11.4	8.68	16.2	15.5	8.55	17.5	14.3	8.91	18.6	11.1	9.16
	32.2	18.3	18.0	8.00	20.0	18.2	8.24	21.4	15.7	8.39	16.8	16.5	8.19	18.3	16.7	8.45	19.6	14.4	8.70	16.5	16.2	8.57	17.8	16.2	8.93	19.0	14.0	9.19
2300	23.9	17.9	15.0	8.14	19.5	11.2	8.38	20.7	4.9	8.53	16.4	13.8	8.33	17.9	10.3	8.59	19.1	4.5	8.84	16.1	13.6	8.71	17.4	10.1	9.07	18.5	4.4	9.32
	26.7	18.3	16.9	8.16	19.9	14.1	8.40	21.2	9.3	8.55	16.8	15.5	8.35	18.3	12.9	8.61	19.5	8.5	8.86	16.5	15.2	8.73	17.8	12.6	9.09	18.9	8.3	9.34
	29.4	18.6	18.3	8.18	20.2	17.0	8.42	21.6	13.2	8.57	17.1	16.8	8.37	18.6	15.6	8.63	19.8	12.1	8.88	16.8	16.5	8.75	18.1	15.2	9.11	19.2	11.7	9.36
	32.2	19.0	19.0	8.20	20.7	19.1	8.44	22.0	16.4	8.59	17.4	17.4	8.39	19.0	17.6	8.65	20.2	15.1	8.90	17.1	17.1	8.77	18.5	17.1	9.14	19.6	14.6	9.39
2500	23.9	18.4	16.9	7.84	20.0	12.5	8.23	21.2	5.5	8.23	16.9	15.5	8.57	18.4	11.5	8.83	19.6	5.1	9.08	16.6	15.3	8.95	17.9	11.2	9.31	19.0	4.9	9.56
	26.7	18.8	18.8	7.86	20.4	15.7	8.10	21.7	10.4	8.25	17.3	17.3	8.59	18.8	14.4	8.85	20.0	9.5	9.10	17.0	17.0	8.97	18.3	14.0	9.33	19.4	9.3	9.58
	29.4	19.1	19.1	7.88	20.8	19.0	8.12	22.1	14.6	8.27	17.6	17.6	8.61	19.1	17.5	8.87	20.3	13.5	9.12	17.3	17.3	8.99	18.6	17.1	9.35	19.7	13.1	9.60
	32.2	19.5	19.5	7.90	21.2	19.2	8.14	22.5	18.3	8.29	17.9	17.9	8.63	19.5	17.7	8.89	20.8	16.9	9.15	17.6	17.6	9.01	19.0	17.3	9.38	20.1	16.4	9.63
2800	23.9	18.9	16.7	8.69	20.4	12.2	8.93	21.7	5.3	9.08	17.4	15.4	8.88	18.9	11.3	9.14	20.0	4.9	9.39	17.1	15.1	9.26	18.4	11.0	9.62	19.5	4.8	9.87
	26.7	19.3	18.5	8.71	20.9	15.3	8.95	22.2	10.1	9.10	17.8	17.1	8.90	19.3	14.2	9.16	20.5	9.3	9.41	17.5	16.8	9.28	18.8	13.8	9.64	19.9	9.0	9.89
	29.4	19.6	19.6	8.73	21.3	18.5	8.97	22.6	14.3	9.12	18.1	18.1	8.92	19.6	17.1	9.18	20.9	13.2	9.43	17.8	17.8	9.30	19.1	16.6	9.66	20.3	12.8	9.91
	32.2	20.0	20.0	8.75	21.7	20.9	8.99	23.0	17.9	9.15	18.5	18.5	8.94	20.0	19.3	9.21	21.3	16.5	9.46	18.2	18.2	9.33	19.5	18.8	9.69	20.7	16.0	9.94

Notes:

- 1. DB = Dry Bulb Temperature (°C), WB = Wet Bulb Temperature (°C)
- 4. TGC = Total Cooling Capacity (kW)
- 5. SHC = Sensible Heating Capacity (kW)
- 6. PI = Power Input (kW)

7.1.2 MTA-76HRN1

Gross Cooling Capacity (kW)																			
Outdoor DB(°C)		29.40									35.00								
Indoor	WB(°C)	16.10			19.40			22.80			16.10			19.40			22.80		
CFM	DB(°C)	TGC	SHC	PI	TGC	SHC	PI	TGC	SHC	PI	TGC	SHC	PI	TGC	SHC	PI	TGC	SHC	PI
2000	23.9	19.2	15.0	6.38	21.6	12.2	6.58	23.0	5.3	6.71	18.4	15.1	6.81	20.5	11.6	7.04	21.7	5.0	7.18
	26.7	19.9	17.2	6.40	22.1	14.3	6.60	23.5	10.1	6.73	18.8	17.1	6.83	20.9	13.5	7.06	22.2	9.6	7.20
	29.4	20.6	18.7	6.42	22.5	18.5	6.62	23.9	14.3	6.75	19.2	18.4	6.85	21.3	17.5	7.08	22.6	13.5	7.22
	32.2	21.3	20.9	6.43	23.0	20.9	6.63	24.4	18.0	6.76	19.6	19.2	6.86	21.7	19.7	7.10	23.1	17.0	7.24
2300	23.9	20.3	16.2	6.58	22.3	12.9	6.78	23.6	5.6	6.91	19.4	16.3	7.01	21.1	12.2	7.24	22.4	5.3	7.38
	26.7	21.0	18.3	6.60	22.7	16.1	6.80	24.1	10.6	6.93	19.8	18.3	7.03	21.5	15.2	7.26	22.8	10.0	7.40
	29.4	21.7	20.1	6.62	23.2	19.5	6.82	24.6	15.0	6.95	20.2	19.8	7.05	21.9	18.4	7.28	23.3	14.2	7.42
	32.2	22.5	21.4	6.63	23.6	21.9	6.83	25.1	18.7	6.96	20.6	20.6	7.07	22.4	20.7	7.30	23.7	17.7	7.44
2500	23.9	20.8	18.1	6.82	22.7	14.2	7.15	24.1	6.2	7.15	19.9	18.3	7.25	21.6	13.5	7.48	22.8	5.9	7.62
	26.7	21.5	20.5	6.84	23.2	17.8	7.04	24.6	11.8	7.17	20.3	20.3	7.27	22.0	16.9	7.50	23.3	11.1	7.64
	29.4	22.3	21.6	6.86	23.7	21.7	7.06	25.1	16.6	7.19	20.7	20.7	7.29	22.4	20.6	7.52	23.8	15.7	7.66
	32.2	23.0	22.6	6.87	24.1	21.9	7.08	25.6	20.8	7.21	21.1	21.1	7.31	22.9	20.8	7.54	24.2	19.7	7.68
2800	23.9	21.3	18.8	7.13	23.2	13.9	7.33	24.6	6.0	7.46	20.7	18.3	7.56	22.1	13.2	7.79	23.3	5.7	7.93
	26.7	22.0	21.2	7.15	23.7	17.4	7.35	25.1	11.4	7.48	21.1	20.3	7.58	22.5	16.5	7.81	23.8	10.8	7.95
	29.4	22.8	22.1	7.17	24.2	21.0	7.37	25.6	16.2	7.50	21.5	21.5	7.60	23.0	20.0	7.83	24.3	15.4	7.97
	32.2	23.6	23.1	7.19	24.7	23.7	7.39	26.1	20.2	7.52	22.0	22.0	7.62	23.4	22.5	7.85	24.8	19.2	7.99

Gross Cooling Capacity (kW)																												
Outdoor DB(°C)		40.60									46.10									51.70								
Indoor	WB(°C)	16.10			19.40			22.80			16.10			19.40			22.80			16.10			19.40			22.80		
CFM	DB(°C)	TGC	SHC	PI	TGC	SHC	PI	TGC	SHC	PI	TGC	SHC	PI	TGC	SHC	PI	TGC	SHC	PI	TGC	SHC	PI	TGC	SHC	PI	TGC	SHC	PI
2000	23.9	17.2	14.1	8.01	18.7	10.6	8.25	20.0	4.6	8.40	15.7	12.9	8.20	17.2	9.7	8.46	18.4	4.2	8.71	15.2	12.5	8.76	16.5	9.3	9.12	17.6	4.1	9.37
	26.7	17.5	15.9	8.03	19.1	12.4	8.27	20.4	8.8	8.42	16.0	14.6	8.22	17.5	11.3	8.48	18.7	8.1	8.73	15.5	14.1	8.78	16.8	10.9	9.14	17.9	7.7	9.39
	29.4	17.9	17.2	8.05	19.5	16.0	8.29	20.8	12.4	8.44	16.3	15.7	8.24	17.9	14.6	8.50	19.1	11.4	8.75	15.8	15.2	8.80	17.2	14.1	9.16	18.3	10.9	9.41
	32.2	18.2	17.9	8.07	19.9	18.1	8.31	21.2	15.6	8.46	16.7	16.3	8.26	18.2	16.6	8.52	19.5	14.3	8.77	16.1	15.8	8.82	17.5	15.9	9.19	18.6	13.7	9.44
2300	23.9	17.8	14.9	8.21	19.4	11.2	8.45	20.6	4.9	8.60	16.3	13.7	8.40	17.8	10.3	8.66	19.0	4.5	8.91	15.8	13.3	8.96	17.1	9.9	9.32	18.2	4.3	9.57
	26.7	18.1	16.8	8.23	19.7	14.0	8.47	21.0	9.2	8.62	16.6	15.4	8.42	18.1	12.9	8.68	19.3	8.5	8.93	16.1	14.9	8.98	17.4	12.4	9.34	18.5	8.1	9.59
	29.4	18.5	18.1	8.25	20.1	16.9	8.49	21.5	13.1	8.64	17.0	16.6	8.44	18.5	15.5	8.70	19.7	12.0	8.95	16.5	16.1	9.00	17.8	14.9	9.36	18.9	11.5	9.61
	32.2	18.9	18.9	8.27	20.5	19.0	8.51	21.9	16.3	8.66	17.3	17.3	8.46	18.9	17.5	8.72	20.1	15.0	8.97	16.8	16.8	9.02	18.1	16.8	9.39	19.3	14.4	9.64
2500	23.9	18.3	16.8	7.91	19.8	12.4	8.30	21.1	5.5	8.30	16.8	15.4	8.64	18.3	11.4	8.90	19.5	5.0	9.15	16.3	15.0	9.20	17.6	11.0	9.56	18.7	4.8	9.81
	26.7	18.6	18.6	7.93	20.2	15.6	8.17	21.5	10.3	8.32	17.1	17.1	8.66	18.6	14.3	8.92	19.8	9.5	9.17	16.6	16.6	9.22	17.9	13.8	9.58	19.0	9.1	9.83
	29.4	19.0	19.0	7.95	20.6	18.9	8.19	22.0	14.6	8.34	17.5	17.5	8.68	19.0	17.4	8.94	20.2	13.4	9.19	17.0	17.0	9.24	18.3	16.8	9.60	19.4	12.9	9.85
	32.2	19.4	19.4	7.97	21.1	19.1	8.21	22.4	18.2	8.36	17.8	17.8	8.70	19.4	17.6	8.96	20.6	16.8	9.22	17.3	17.3	9.27	18.7	17.0	9.63	19.8	16.1	9.88
2800	23.9	18.8	16.6	8.76	20.3	12.2	9.00	21.6	5.3	9.15	17.3	15.3	8.95	18.8	11.2	9.21	19.9	4.9	9.46	16.8	14.9	9.51	18.1	10.8	9.87	19.2	4.7	10.11
	26.7	19.1	18.4	8.78	20.7	15.3	9.02	22.0	10.0	9.17	17.6	17.0	8.97	19.1	14.1	9.23	20.3	9.2	9.48	17.1	16.5	9.53	18.4	13.6	9.89	19.5	8.9	10.14
	29.4	19.5	19.5	8.80	21.2	18.4	9.04	22.5	14.2	9.19	18.0	18.0	8.99	19.5	17.0	9.25	20.7	13.1	9.50	17.5	17.5	9.55	18.8	16.4	9.91	19.9	12.6	10.17
	32.2	19.9	19.9	8.82	21.6	20.7	9.07	22.9	17.8	9.22	18.4	18.4	9.01	19.9	19.1	9.28	21.2	16.4	9.53	17.8	17.8	9.58	19.2	18.4	9.94	20.3	15.8	10.19

Notes:

- 1. DB = Dry Bulb Temperature (°C), WB = Wet Bulb Temperature (°C)
- 4. TGC = Total Cooling Capacity (kW)
- 5. SHC = Sensible Heating Capacity (kW)
- 6. PI = Power Input (kW)

7.1.3 MTA-96CRN1

Gross Cooling Capacity (kW)																			
Outdoor DB(°C)		29.40									35.00								
Indoor	WB(°C)	16.10			19.40			22.80			16.10			19.40			22.80		
CFM	DB(°C)	TGC	SHC	PI	TGC	SHC	PI	TGC	SHC	PI	TGC	SHC	PI	TGC	SHC	PI	TGC	SHC	PI
2440	23.9	25.3	19.8	8.50	27.8	15.7	8.70	29.2	6.7	8.83	24.6	20.2	8.93	26.6	15.1	9.16	27.9	6.4	9.30
	26.7	26.2	22.6	8.52	28.4	18.4	8.72	29.8	12.8	8.85	25.1	22.8	8.95	27.2	17.6	9.18	28.5	12.3	9.32
	29.4	27.1	24.7	8.54	28.9	23.7	8.74	30.4	18.1	8.87	25.6	24.6	8.97	27.7	22.7	9.20	29.0	17.3	9.34
	32.2	28.1	27.5	8.56	29.5	26.8	8.76	31.0	22.8	8.89	26.1	25.6	8.99	28.3	25.7	9.23	29.6	21.8	9.37
2740	23.9	26.4	21.1	8.70	28.4	16.4	8.90	29.8	7.0	9.03	25.6	21.5	9.13	27.3	15.8	9.36	28.5	6.7	9.50
	26.7	27.3	23.7	8.72	29.0	20.6	8.92	30.4	13.3	9.05	26.1	24.2	9.15	27.8	19.7	9.38	29.1	12.8	9.52
	29.4	28.3	26.2	8.74	29.6	24.9	8.94	31.0	18.9	9.07	26.6	26.1	9.17	28.4	23.8	9.40	29.7	18.1	9.54
	32.2	29.2	27.9	8.76	30.2	27.9	8.96	31.6	23.6	9.10	27.2	27.2	9.20	28.9	26.8	9.43	30.3	22.6	9.57
3000	23.9	26.9	23.4	8.94	28.9	18.1	9.27	30.3	7.8	9.27	26.1	23.9	9.37	27.7	17.3	9.55	29.0	7.5	9.74
	26.7	27.8	26.5	8.96	29.5	22.7	9.16	30.9	14.8	9.29	26.6	26.6	9.39	28.0	21.8	9.60	29.6	14.2	9.76
	29.4	28.8	27.9	8.98	30.1	27.6	9.18	31.5	20.9	9.31	27.1	27.1	9.41	28.9	26.5	9.64	30.2	20.0	9.78
	32.2	29.8	29.2	9.00	30.7	27.9	9.21	32.1	26.1	9.34	27.7	27.7	9.44	29.4	26.8	9.67	30.8	25.0	9.81
3240	23.9	27.3	24.2	9.25	29.4	17.6	9.45	30.8	7.5	9.58	26.9	23.8	9.68	28.2	16.9	9.91	29.5	7.2	10.04
	26.7	28.3	27.2	9.27	30.0	22.1	9.47	31.4	14.3	9.60	27.4	26.3	9.70	28.8	21.2	9.93	30.1	13.7	10.07
	29.4	29.3	28.4	9.29	30.6	26.6	9.49	32.0	20.3	9.62	27.9	27.9	9.72	29.4	25.5	9.95	30.7	19.4	10.10
	32.2	30.3	29.7	9.32	31.2	30.0	9.52	32.7	25.3	9.65	28.5	28.5	9.75	30.0	28.8	9.98	31.3	24.3	10.12

Gross Cooling Capacity (kW)																												
Outdoor DB(°C)		40.60									46.10									51.70								
Indoor	WB(°C)	16.10			19.40			22.80			16.10			19.40			22.80			16.10			19.40			22.80		
CFM	DB(°C)	TGC	SHC	PI	TGC	SHC	PI	TGC	SHC	PI	TGC	SHC	PI	TGC	SHC	PI	TGC	SHC	PI	TGC	SHC	PI	TGC	SHC	PI	TGC	SHC	PI
2440	23.9	22.0	18.0	10.63	23.6	13.3	10.87	24.8	5.7	11.02	20.5	16.8	10.82	22.0	12.4	11.08	23.2	5.4	11.33	20.0	16.4	11.42	21.3	12.0	11.78	22.4	5.2	12.03
	26.7	22.4	20.4	10.66	24.0	15.6	10.90	25.3	10.9	11.05	20.9	19.0	10.85	22.4	14.5	11.11	23.6	10.2	11.36	20.4	18.6	11.45	21.7	14.1	11.81	22.8	9.8	12.06
	29.4	22.9	22.0	10.69	24.5	20.1	10.93	25.8	15.4	11.08	21.3	20.5	10.88	22.9	18.8	11.14	24.1	14.3	11.39	20.8	20.0	11.48	22.2	18.2	11.84	23.3	13.9	12.09
	32.2	23.3	22.9	10.71	25.0	22.7	10.95	26.4	19.4	11.11	21.8	21.3	10.90	23.3	21.2	11.17	24.6	18.1	11.42	21.3	20.8	11.51	22.6	20.6	11.87	23.8	17.5	12.12
2740	23.9	22.6	19.0	10.83	24.2	14.0	11.07	25.4	6.0	11.22	21.1	17.8	11.02	22.6	13.1	11.28	23.8	5.6	11.53	20.6	17.3	11.62	21.9	12.7	11.98	23.0	5.4	12.23
	26.7	23.1	21.3	10.86	24.7	17.5	11.10	26.0	11.4	11.25	21.6	20.0	11.05	23.1	16.3	11.31	24.3	10.6	11.56	21.1	19.5	11.65	22.4	15.9	12.01	23.5	10.3	12.26
	29.4	23.5	23.1	10.89	25.1	21.1	11.13	26.5	16.1	11.28	22.0	21.6	11.08	23.5	19.8	11.34	24.7	15.1	11.59	21.5	21.1	11.68	22.8	19.2	12.04	23.9	14.6	12.29
	32.2	24.0	24.0	10.91	25.6	23.7	11.16	27.0	20.1	11.31	22.4	22.4	11.11	24.0	22.2	11.37	25.2	18.8	11.62	21.9	21.9	11.71	23.3	21.5	12.07	24.4	18.2	12.32
3000	23.9	23.1	21.2	11.07	24.7	15.4	11.46	25.9	6.7	11.46	21.6	19.8	11.26	23.1	14.4	11.52	24.3	6.3	11.77	21.1	19.4	11.86	22.4	14.0	12.22	23.5	6.1	12.47
	26.7	23.6	23.6	11.10	25.2	19.3	11.34	26.5	12.7	11.49	22.1	22.1	11.29	23.6	18.1	11.55	24.8	11.8	11.80	21.6	21.6	11.89	22.9	17.6	12.25	24.0	11.5	12.50
	29.4	24.0	24.0	11.13	25.7	23.5	11.37	27.0	17.9	11.52	22.5	22.5	11.32	24.0	22.0	11.58	25.2	16.7	11.83	22.0	22.0	11.92	23.3	21.4	12.28	24.4	16.2	12.53
	32.2	24.5	24.5	11.16	26.2	23.8	11.40	27.5	22.4	11.55	22.9	22.9	11.35	24.5	22.3	11.61	25.7	20.9	11.86	22.4	22.4	11.95	23.8	21.6	12.31	24.9	20.3	12.56
3240	23.9	23.6	20.9	11.38	25.1	15.1	11.62	26.4	6.5	11.77	22.1	19.6	11.57	23.6	14.1	11.83	24.8	6.1	12.08	21.6	19.1	12.17	22.9	13.7	12.53	24.0	5.9	12.78
	26.7	24.1	23.1	11.41	25.7	18.9	11.65	27.0	12.3	11.80	22.6	21.7	11.60	24.1	17.7	11.86	25.3	11.5	12.11	22.1	21.2	12.20	23.4	17.2	12.56	24.5	11.1	12.81
	29.4	24.5	24.5	11.44	26.2	22.8	11.68	27.5	17.4	11.83	23.0	23.0	11.63	24.5	21.3	11.89	25.8	16.3	12.14	22.5	22.5	12.23	23.8	20.7	12.59	24.9	15.8	12.84
	32.2	25.0	25.0	11.47	26.7	25.7	11.71	28.0	21.7	11.86	23.5	23.5	11.66	25.0	24.1	11.92	26.3	20.4	12.17	22.9	22.9	12.26	24.3	23.4	12.62	25.4	19.7	12.87

Notes:

1. DB = Dry Bulb Temperature (°C), WB = Wet Bulb Temperature (°C)
4. TGC = Total Cooling Capacity (kW)
5. SHC = Sensible Heating Capacity (kW)
6. PI = Power Input (kW)

7.1.4 MTA-96HRN1

Gross Cooling Capacity (kW)																			
Outdoor DB(°C)		29.40									35.00								
Indoor	WB(°C)	16.10			19.40			22.80			16.10			19.40			22.80		
CFM	DB(°C)	TGC	SHC	PI	TGC	SHC	PI	TGC	SHC	PI	TGC	SHC	PI	TGC	SHC	PI	TGC	SHC	PI
2440	23.9	24.9	19.4	8.47	27.4	15.5	8.67	28.8	6.6	8.80	24.2	19.8	8.90	26.2	14.8	9.13	27.5	6.3	9.27
	26.7	25.8	22.2	8.49	27.9	18.1	8.69	29.3	12.6	8.82	24.7	22.4	8.92	26.7	17.3	9.15	28.0	12.1	9.29
	29.4	26.7	24.2	8.51	28.5	23.4	8.71	29.9	17.8	8.84	25.1	24.2	8.94	27.3	22.3	9.17	28.6	17.0	9.31
	32.2	27.6	27.0	8.53	29.1	26.4	8.73	30.5	22.4	8.86	25.6	25.1	8.96	27.8	25.3	9.20	29.2	21.4	9.34
2740	23.9	25.9	20.8	8.67	28.0	16.2	8.87	29.4	6.9	9.00	25.1	21.1	9.10	26.8	15.5	9.33	28.1	6.6	9.47
	26.7	26.9	23.3	8.69	28.6	20.2	8.89	30.0	13.1	9.02	25.7	23.8	9.12	27.4	19.4	9.35	28.7	12.6	9.49
	29.4	27.8	25.7	8.71	29.1	24.5	8.91	30.5	18.6	9.04	26.2	25.7	9.14	27.9	23.4	9.37	29.2	17.8	9.51
	32.2	28.8	27.4	8.73	29.7	27.5	8.93	31.2	23.3	9.07	26.7	26.7	9.17	28.5	26.3	9.40	29.8	22.2	9.54
3000	23.9	26.4	23.0	8.91	28.5	17.8	9.24	29.9	7.7	9.24	25.6	23.5	9.34	27.3	17.1	9.57	28.6	7.4	9.71
	26.7	27.4	26.0	8.93	29.1	22.3	9.13	30.5	14.6	9.26	26.2	26.2	9.36	28.0	21.4	9.60	29.2	13.9	9.73
	29.4	28.3	27.5	8.95	29.6	27.2	9.15	31.1	20.6	9.28	26.7	26.7	9.38	28.4	26.1	9.61	29.7	19.7	9.75
	32.2	29.3	28.7	8.97	30.2	27.5	9.18	31.7	25.8	9.31	27.2	27.2	9.41	29.0	26.3	9.64	30.3	24.7	9.78
3240	23.9	26.9	23.8	9.22	29.0	17.3	9.42	30.3	7.4	9.55	26.4	23.4	9.65	27.8	16.6	9.88	29.1	7.1	10.01
	26.7	27.9	26.8	9.24	29.6	21.7	9.44	31.0	14.1	9.57	27.0	25.9	9.67	28.4	20.8	9.90	29.7	13.5	10.04
	29.4	28.8	28.0	9.26	30.1	26.2	9.46	31.6	20.0	9.59	27.5	27.5	9.69	28.9	25.1	9.92	30.2	19.1	10.07
	32.2	29.8	29.2	9.29	30.7	29.6	9.49	32.2	25.0	9.62	28.0	28.0	9.72	29.5	28.4	9.95	30.8	23.9	10.09

Gross Cooling Capacity (kW)																												
Outdoor DB(°C)		40.60									46.10									51.70								
Indoor	WB(°C)	16.10			19.40			22.80			16.10			19.40			22.80			16.10			19.40			22.80		
CFM	DB(°C)	TGC	SHC	PI	TGC	SHC	PI	TGC	SHC	PI	TGC	SHC	PI	TGC	SHC	PI	TGC	SHC	PI	TGC	SHC	PI	TGC	SHC	PI	TGC	SHC	PI
2440	23.9	22.0	18.0	10.83	23.5	13.3	11.07	24.8	5.7	11.22	20.5	16.8	11.02	22.0	12.4	11.28	23.1	5.3	11.53	19.4	15.9	11.52	20.7	11.7	11.88	21.8	5.0	12.13
	26.7	22.4	20.4	10.86	24.0	15.5	11.10	25.3	10.9	11.25	20.9	19.0	11.05	22.4	14.5	11.31	23.6	10.2	11.56	19.8	18.0	11.55	21.1	13.7	11.91	22.2	9.6	12.16
	29.4	22.8	22.0	10.89	24.5	20.1	11.13	25.8	15.4	11.28	21.3	20.5	11.08	22.8	18.7	11.34	24.1	14.3	11.59	20.2	19.4	11.58	21.5	17.6	11.94	22.7	13.5	12.19
	32.2	23.3	22.8	10.91	25.0	22.7	11.16	26.3	19.4	11.31	21.7	21.3	11.11	23.3	21.2	11.37	24.6	18.1	11.62	20.6	20.2	11.61	22.0	20.0	11.97	23.1	17.0	12.22
2740	23.9	22.6	19.0	11.03	24.1	14.0	11.27	25.4	6.0	11.42	21.1	17.7	11.22	22.6	13.0	11.48	23.7	5.6	11.73	20.0	16.8	11.72	21.3	12.3	12.08	22.4	5.3	12.33
	26.7	23.0	21.3	11.06	24.6	17.5	11.30	25.9	11.4	11.45	21.5	19.9	11.25	23.0	16.3	11.51	24.2	10.6	11.76	20.4	18.9	11.75	21.7	15.4	12.11	22.8	10.0	12.36
	29.4	23.5	23.0	11.09	25.1	21.1	11.33	26.4	16.1	11.48	22.0	21.5	11.28	23.5	19.7	11.54	24.7	15.1	11.79	20.8	20.4	11.78	22.2	18.6	12.14	23.3	14.2	12.39
	32.2	24.0	24.0	11.12	25.6	23.7	11.36	27.0	20.1	11.51	22.4	22.4	11.31	24.0	22.2	11.57	25.2	18.8	11.82	21.3	21.3	11.81	22.6	20.9	12.17	23.8	17.7	12.42
3000	23.9	23.1	21.2	11.27	24.6	15.4	11.66	25.9	6.7	11.66	21.6	19.8	11.46	23.1	14.4	11.72	24.2	6.3	11.97	20.5	18.8	11.96	21.8	13.6	12.32	22.9	5.9	12.57
	26.7	23.5	23.5	11.30	25.1	19.3	11.54	26.4	12.6	11.69	22.0	22.0	11.49	23.3	18.1	11.75	24.7	11.8	12.00	20.9	20.9	11.99	22.2	17.1	12.35	23.3	11.2	12.60
	29.4	24.0	24.0	11.33	25.6	23.5	11.57	26.9	17.8	11.72	22.5	22.5	11.52	24.0	22.0	11.78	25.2	16.7	12.03	21.3	21.3	12.02	22.7	20.8	12.38	23.8	15.8	12.63
	32.2	24.5	24.5	11.36	26.1	23.8	11.60	27.5	22.3	11.75	22.9	22.9	11.55	24.5	22.2	11.81	25.7	20.9	12.06	21.8	21.8	12.05	23.1	21.0	12.41	24.3	19.7	12.66
3240	23.9	23.5	20.8	11.58	25.1	15.0	11.82	26.4	6.5	11.97	22.1	19.5	11.77	23.5	14.1	12.03	24.7	6.1	12.28	21.0	18.6	12.27	22.3	13.3	12.63	23.4	5.7	12.88
	26.7	24.0	23.1	11.61	25.6	18.8	11.85	26.9	12.2	12.00	22.5	21.7	11.80	24.0	17.7	12.06	25.2	11.5	12.31	21.4	20.6	12.30	22.7	16.7	12.66	23.8	10.8	12.91
	29.4	24.5	24.5	11.64	26.1	22.7	11.88	27.5	17.4	12.03	23.0	23.0	11.83	24.5	21.3	12.09	25.7	16.3	12.34	21.9	21.9	12.33	23.2	20.2	12.69	24.3	15.4	12.94
	32.2	25.0	25.0	11.67	26.7	25.6	11.91	28.0	21.7	12.06	23.4	23.4	11.86	25.0	24.0	12.12	26.2	20.3	12.37	22.3	22.3	12.36	23.6	22.7	12.72	24.8	19.2	12.97

Notes:

- 1. DB = Dry Bulb Temperature (°C), WB = Wet Bulb Temperature (°C)
- 4. TGC = Total Cooling Capacity (kW)
- 5. SHC = Sensible Heating Capacity (kW)
- 6. PI = Power Input (kW)

7.1.5 MTA-120CRN1

Gross Cooling Capacity (kW)																			
Outdoor DB(°C)		29.40									35.00								
Indoor	WB(°C)	16.10			19.40			22.80			16.10			19.40			22.80		
CFM	DB(°C)	TGC	SHC	PI	TGC	SHC	PI	TGC	SHC	PI	TGC	SHC	PI	TGC	SHC	PI	TGC	SHC	PI
3200	23.9	32.0	25.0	10.99	34.6	19.5	11.19	36.0	8.3	11.32	31.4	25.7	11.42	33.4	18.9	11.65	34.7	8.0	11.79
	26.7	33.1	28.5	11.02	35.3	22.8	11.22	36.7	15.8	11.35	32.0	29.1	11.45	34.1	22.1	11.68	35.4	15.3	11.82
	29.4	34.3	31.1	11.05	36.0	29.5	11.25	37.4	22.3	11.38	32.6	31.4	11.48	34.8	28.5	11.71	36.1	21.5	11.85
	32.2	35.5	34.8	11.08	36.7	33.4	11.28	38.2	28.1	11.41	33.3	32.6	11.51	35.5	32.2	11.74	36.8	27.1	11.88
3500	23.9	33.0	26.4	11.19	35.2	20.3	11.39	36.6	8.6	11.52	32.4	27.2	11.62	34.0	19.7	11.85	35.3	8.3	11.99
	26.7	34.2	29.7	11.22	35.9	25.5	11.42	37.3	16.4	11.55	33.0	30.6	11.65	34.7	24.6	11.88	36.0	15.8	12.02
	29.4	35.4	32.8	11.25	36.6	30.8	11.45	38.0	23.2	11.58	33.7	33.0	11.68	35.4	29.7	11.91	36.7	22.4	12.05
	32.2	36.6	34.9	11.28	37.4	34.6	11.48	38.8	29.0	11.61	34.3	34.3	11.71	36.1	33.4	11.94	37.5	28.0	12.08
3750	23.9	33.5	29.2	11.43	35.7	22.3	11.76	37.1	9.6	11.76	32.8	30.1	11.86	34.5	21.6	11.98	35.8	9.3	12.23
	26.7	34.7	33.0	11.46	36.4	28.0	11.66	37.8	18.1	11.79	33.5	33.5	11.89	35.0	27.1	12.00	36.5	17.5	12.26
	29.4	35.9	34.9	11.49	37.1	34.1	11.69	38.6	25.5	11.82	34.2	34.2	11.92	35.9	32.9	12.15	37.2	24.7	12.29
	32.2	37.2	36.4	11.52	37.9	34.4	11.72	39.3	32.0	11.85	34.9	34.9	11.95	36.6	33.3	12.18	38.0	30.9	12.32
4000	23.9	34.0	30.1	11.74	36.2	21.7	11.94	37.5	9.2	12.07	33.6	29.8	12.17	35.0	21.0	12.40	36.3	8.9	12.54
	26.7	35.2	33.8	11.77	36.9	27.1	11.97	38.3	17.4	12.10	34.3	33.0	12.20	35.7	26.3	12.43	37.0	16.8	12.57
	29.4	36.4	35.4	11.80	37.6	32.7	12.00	39.1	24.7	12.13	35.0	35.0	12.23	36.4	31.7	12.46	37.7	23.9	12.60
	32.2	37.7	37.0	11.83	38.4	36.9	12.03	39.8	30.9	12.16	35.7	35.7	12.26	37.1	35.7	12.49	38.5	29.8	12.63

Gross Cooling Capacity (kW)																												
Outdoor DB(°C)		40.60									46.10									51.70								
Indoor	WB(°C)	16.10			19.40			22.80			16.10			19.40			22.80			16.10			19.40			22.80		
CFM	DB(°C)	TGC	SHC	PI	TGC	SHC	PI	TGC	SHC	PI	TGC	SHC	PI	TGC	SHC	PI	TGC	SHC	PI	TGC	SHC	PI	TGC	SHC	PI	TGC	SHC	PI
3200	23.9	23.9	28.3	23.2	12.33	29.9	16.9	12.57	31.1	7.2	12.72	26.8	22.0	12.52	28.3	16.0	12.78	29.5	6.8	13.03	26.5	21.8	14.01	27.8	15.7	14.37	28.9	6.7
	26.7	26.7	28.9	26.2	12.36	30.5	19.7	12.60	31.8	13.7	12.75	27.4	24.9	12.55	28.9	18.7	12.81	30.1	13.0	13.06	27.1	24.6	14.05	28.4	18.4	14.41	29.5	12.7
	29.4	29.4	29.4	28.3	12.39	31.1	25.5	12.63	32.4	19.3	12.78	27.9	26.8	12.58	29.4	24.1	12.84	30.7	18.3	13.09	27.6	26.6	14.09	28.9	23.7	14.45	30.1	17.9
	32.2	32.2	30.0	29.4	12.42	31.7	28.8	12.66	33.0	24.3	12.81	28.5	27.9	12.61	30.0	27.3	12.87	31.3	23.0	13.13	28.2	27.6	14.12	29.5	26.8	14.48	30.7	22.6
3500	23.9	23.9	28.9	24.3	12.53	30.5	17.6	12.77	31.7	7.5	12.92	27.4	23.1	12.72	28.9	16.7	12.98	30.1	7.1	13.23	27.2	22.8	14.21	28.4	16.4	14.57	29.5	7.0
	26.7	26.7	29.5	27.3	12.56	31.1	22.0	12.80	32.4	14.2	12.95	28.0	25.9	12.75	29.5	20.9	13.01	30.7	13.5	13.26	27.7	25.6	14.25	29.0	20.6	14.61	30.1	13.2
	29.4	29.4	30.1	29.5	12.59	31.7	26.6	12.83	33.0	20.1	12.98	28.5	28.0	12.78	30.1	25.3	13.04	31.3	19.1	13.29	28.3	27.7	14.29	29.6	24.9	14.65	30.7	18.7
	32.2	32.2	30.7	30.7	12.62	32.3	29.9	12.86	33.7	25.1	13.01	29.1	29.1	12.81	30.7	28.4	13.08	31.9	23.8	13.33	28.8	28.8	14.32	30.2	27.9	14.68	31.3	23.4
3750	23.9	23.9	29.4	27.0	12.23	31.0	19.4	12.62	32.2	8.4	12.62	27.9	25.6	12.96	29.4	18.4	13.22	30.6	7.9	13.47	27.6	25.4	14.45	28.9	18.1	14.81	30.0	7.8
	26.7	26.7	30.0	30.0	12.26	31.6	24.3	12.50	32.9	15.7	12.65	28.5	28.5	12.99	30.0	23.1	13.25	31.2	14.9	13.50	28.2	28.2	14.49	29.5	22.7	14.85	30.6	14.6
	29.4	29.4	30.6	30.6	12.29	32.2	29.6	12.53	33.5	22.2	12.68	29.0	29.0	13.02	30.6	28.1	13.28	31.8	21.1	13.53	28.8	28.8	14.53	30.1	27.6	14.89	31.2	20.7
	32.2	32.2	31.2	31.2	12.32	32.9	29.9	12.56	34.2	27.8	12.71	29.6	29.6	13.06	31.2	28.4	13.32	32.4	26.4	13.57	29.3	29.3	14.56	30.7	27.9	14.92	31.8	25.9
4000	23.9	23.9	29.9	26.4	13.08	31.5	18.8	13.32	32.7	8.0	13.47	28.4	25.1	13.27	29.9	17.9	13.53	31.1	7.6	13.78	28.1	24.9	14.76	29.4	17.6	15.12	30.5	7.5
	26.7	26.7	30.5	29.3	13.11	32.1	23.6	13.35	33.4	15.2	13.50	29.0	27.9	13.30	30.5	22.4	13.56	31.7	14.4	13.81	28.7	27.6	14.80	30.0	22.1	15.16	31.1	14.1
	29.4	29.4	31.1	31.1	13.14	32.7	28.5	13.38	34.0	21.5	13.53	29.6	29.6	13.33	31.1	27.0	13.59	32.3	20.5	13.84	29.3	29.3	14.84	30.6	26.6	15.20	31.7	20.1
	32.2	32.2	31.7	31.7	13.18	33.4	32.1	13.42	34.7	26.9	13.57	30.2	30.2	13.37	31.7	30.5	13.63	33.0	25.6	13.88	29.9	29.9	14.87	31.2	30.0	15.24	32.4	25.1

Notes:

1. DB = Dry Bulb Temperature (°C), WB = Wet Bulb Temperature (°C)
4. TGC = Total Cooling Capacity (kW)
5. SHC = Sensible Heating Capacity (kW)
6. PI = Power Input (kW)

7.1.6 MTA-120HR

Gross Cooling Capacity (kW)																			
Outdoor DB(°C)		29.40									35.00								
Indoor	WB(°C)	16.10			19.40			22.80			16.10			19.40			22.80		
CFM	DB(°C)	TGC	SHC	PI	TGC	SHC	PI	TGC	SHC	PI	TGC	SHC	PI	TGC	SHC	PI	TGC	SHC	PI
3200	23.9	31.8	24.8	10.87	34.4	19.4	11.07	35.8	8.3	11.20	31.2	25.6	11.30	33.2	18.8	11.53	34.5	8.0	11.67
	26.7	32.9	28.4	10.90	35.1	22.7	11.10	36.5	15.7	11.23	31.8	28.9	11.33	33.9	21.9	11.56	35.2	15.2	11.70
	29.4	34.1	31.0	10.93	35.8	29.3	11.13	37.2	22.1	11.26	32.4	31.2	11.36	34.6	28.3	11.59	35.9	21.4	11.73
	32.2	35.2	34.6	10.95	36.5	33.2	11.16	38.0	27.9	11.29	33.1	32.4	11.39	35.2	32.0	11.62	36.6	26.9	11.76
3500	23.9	32.9	26.3	11.07	35.0	20.2	11.27	36.4	8.6	11.40	32.2	27.0	11.50	33.8	19.6	11.73	35.1	8.3	11.87
	26.7	34.0	29.6	11.10	35.7	25.3	11.30	37.1	16.3	11.43	32.8	30.4	11.53	34.5	24.5	11.76	35.8	15.7	11.90
	29.4	35.2	32.6	11.13	36.4	30.6	11.33	37.8	23.1	11.46	33.5	32.8	11.56	35.2	29.6	11.79	36.5	22.3	11.93
	32.2	36.4	34.7	11.16	37.1	34.4	11.36	38.6	28.8	11.49	34.1	34.1	11.59	35.9	33.2	11.82	37.2	27.8	11.96
3750	23.9	33.3	29.0	11.31	35.5	22.2	11.64	36.9	9.5	11.64	32.6	30.0	11.74	34.3	21.4	11.97	35.6	9.2	12.11
	26.7	34.5	32.9	11.34	36.2	27.8	11.54	37.6	18.0	11.67	33.3	33.3	11.77	35.0	26.9	12.00	36.3	17.4	12.14
	29.4	35.7	34.7	11.37	36.9	33.9	11.57	38.4	25.4	11.70	34.0	34.0	11.80	35.7	32.8	12.03	37.0	24.5	12.17
	32.2	37.0	36.2	11.40	37.7	34.2	11.60	39.1	31.8	11.73	34.6	34.6	11.83	36.4	33.1	12.06	37.8	30.7	12.20
4000	23.9	33.8	29.9	11.62	36.0	21.5	11.82	37.4	9.2	11.95	33.4	29.6	12.05	34.8	20.8	12.28	36.1	8.8	12.42
	26.7	35.0	33.7	11.65	36.7	27.0	11.85	38.1	17.3	11.98	34.1	32.8	12.08	35.5	26.1	12.31	36.8	16.7	12.45
	29.4	36.2	35.2	11.68	37.4	32.6	11.88	38.9	24.6	12.01	34.8	34.8	12.11	36.2	31.5	12.34	37.5	23.8	12.48
	32.2	37.5	36.8	11.71	38.2	36.7	11.91	39.6	30.7	12.04	35.5	35.5	12.14	36.9	35.5	12.37	38.3	29.7	12.51

Gross Cooling Capacity (kW)																												
Outdoor DB(°C)		40.60									46.10									51.70								
Indoor	WB(°C)	16.10			19.40			22.80			16.10			19.40			22.80			16.10			19.40			22.80		
CFM	DB(°C)	TGC	SHC	PI	TGC	SHC	PI	TGC	SHC	PI	TGC	SHC	PI	TGC	SHC	PI	TGC	SHC	PI	TGC	SHC	PI	TGC	SHC	PI	TGC	SHC	PI
3200	23.9	23.9	28.0	22.9	12.73	29.5	16.7	12.97	30.8	7.1	13.12	26.5	21.7	12.92	28.0	15.8	13.18	29.2	6.7	13.43	26.2	21.4	14.72	27.4	15.5	15.08	28.5	6.6
	26.7	26.7	28.5	25.9	12.76	30.1	19.5	13.00	31.4	13.6	13.15	27.0	24.6	12.95	28.5	18.5	13.21	29.7	12.8	13.46	26.7	24.3	14.76	28.0	18.1	15.12	29.1	12.5
	29.4	29.4	29.1	28.0	12.79	30.7	25.2	13.03	32.1	19.1	13.18	27.6	26.5	12.98	29.1	23.9	13.24	30.3	18.1	13.49	27.2	26.2	14.80	28.5	23.4	15.16	29.7	17.7
	32.2	32.2	29.7	29.1	12.82	31.4	28.5	13.07	32.7	24.1	13.22	28.1	27.6	13.01	29.7	27.0	13.28	30.9	22.8	13.53	27.8	27.2	14.83	29.1	26.5	15.20	30.3	22.3
3500	23.9	23.9	28.6	24.0	12.93	30.2	17.4	13.17	31.4	7.4	13.32	27.1	22.8	13.12	28.6	16.5	13.38	29.8	7.0	13.63	26.8	22.5	14.92	28.0	16.2	15.28	29.1	6.9
	26.7	26.7	29.2	27.0	12.96	30.8	21.8	13.20	32.1	14.1	13.35	27.7	25.6	13.15	29.2	20.7	13.41	30.4	13.3	13.66	27.3	25.3	14.96	28.6	20.3	15.32	29.7	13.0
	29.4	29.4	29.7	29.2	12.99	31.4	26.4	13.23	32.7	19.9	13.38	28.2	27.7	13.18	29.7	25.0	13.44	31.0	18.9	13.69	27.9	27.3	15.00	29.2	24.5	15.36	30.3	18.5
	32.2	32.2	30.3	30.3	13.02	32.0	29.6	13.27	33.4	24.9	13.42	28.8	28.8	13.22	30.3	28.1	13.48	31.6	23.6	13.73	28.4	28.4	15.03	29.8	27.6	15.40	30.9	23.1
3750	23.9	23.9	29.1	26.7	12.63	30.6	19.2	13.02	31.9	8.3	13.02	27.6	25.3	13.36	29.1	18.2	13.62	30.3	7.8	13.87	27.3	25.0	15.16	28.5	17.8	15.52	29.6	7.7
	26.7	26.7	29.7	29.7	12.66	31.3	24.0	12.90	32.6	15.6	13.05	28.2	28.2	13.39	29.7	22.8	13.65	30.9	14.8	13.90	27.8	27.8	15.20	29.1	22.4	15.56	30.2	14.5
	29.4	29.4	30.3	30.3	12.69	31.9	29.3	12.93	33.2	22.0	13.08	28.7	28.7	13.42	30.3	27.8	13.68	31.5	20.8	13.93	28.4	28.4	15.24	29.7	27.2	15.60	30.8	20.4
	32.2	32.2	30.9	30.9	12.72	32.5	29.6	12.96	33.9	27.5	13.12	29.3	29.3	13.46	30.9	28.1	13.72	32.1	26.1	13.97	28.9	28.9	15.28	30.3	27.5	15.64	31.4	25.6
4000	23.9	23.9	29.6	26.2	13.48	31.1	18.6	13.72	32.4	7.9	13.87	28.1	24.9	13.67	29.6	17.7	13.93	30.7	7.5	14.17	27.8	24.6	15.47	29.0	17.4	15.83	30.1	7.4
	26.7	26.7	30.2	29.0	13.51	31.8	23.4	13.75	33.1	15.0	13.90	28.7	27.6	13.70	30.2	22.2	13.96	31.4	14.3	14.21	28.3	27.2	15.51	29.6	21.8	15.87	30.7	14.0
	29.4	29.4	30.8	30.8	13.54	32.4	28.2	13.78	33.7	21.3	13.93	29.2	29.2	13.73	30.8	26.8	13.99	32.0	20.2	14.25	28.9	28.9	15.55	30.2	26.3	15.91	31.3	19.8
	32.2	32.2	31.4	31.4	13.58	33.0	31.8	13.82	34.4	26.7	13.97	29.8	29.8	13.77	31.4	30.2	14.03	32.6	25.3	14.28	29.5	29.5	15.59	30.8	29.6	15.95	32.0	24.8

Notes:

1. DB = Dry Bulb Temperature (°C), WB = Wet Bulb Temperature (°C)
4. TGC = Total Cooling Capacity (kW)
5. SHC = Sensible Heating Capacity (kW)
6. PI = Power Input (kW)

7.1.7 MTA-150CRN1

Gross Cooling Capacity (kW)																			
Outdoor DB(°C)		29.40									35.00								
Indoor	WB(°C)	16.10			19.40			22.80			16.10			19.40			22.80		
CFM	DB(°C)	TGC	SHC	PI	TGC	SHC	PI	TGC	SHC	PI	TGC	SHC	PI	TGC	SHC	PI	TGC	SHC	PI
4000	23.9	41.0	32.0	14.20	43.7	24.7	14.40	45.1	10.4	14.53	40.5	33.2	14.63	42.5	24.0	14.86	43.8	10.1	15.00
	26.7	42.4	36.6	14.24	44.6	28.9	14.44	46.0	19.8	14.57	41.3	37.5	14.67	43.4	28.1	14.90	44.7	19.3	15.04
	29.4	43.9	39.9	14.28	45.5	37.3	14.48	46.9	27.9	14.61	42.1	40.5	14.71	44.2	36.3	14.94	45.6	27.1	15.08
	32.2	45.4	44.5	14.31	46.4	42.2	14.51	47.8	35.2	14.64	43.0	42.1	14.74	45.1	41.0	14.97	46.5	34.2	15.12
4300	23.9	42.0	33.6	14.40	44.3	25.6	14.60	45.7	10.8	14.73	41.5	34.8	14.83	43.1	24.9	14.99	44.4	10.5	15.20
	26.7	43.5	37.8	14.44	45.2	32.1	14.64	46.6	20.4	14.77	42.3	39.2	14.87	44.0	31.2	15.01	45.3	19.9	15.24
	29.4	45.0	41.7	14.48	46.1	38.7	14.68	47.5	29.0	14.81	43.1	42.3	14.91	44.9	37.7	15.03	46.2	28.2	15.28
	32.2	46.6	44.4	14.51	47.0	43.5	14.71	48.5	36.2	14.84	44.0	44.0	14.94	45.8	42.4	15.05	47.1	35.2	15.32
4500	23.9	42.5	37.0	14.64	44.8	28.0	14.97	46.2	12.0	14.97	42.0	38.5	15.07	43.6	27.3	15.08	44.9	11.6	15.44
	26.7	44.0	41.9	14.68	45.7	35.2	14.88	47.1	22.5	15.01	42.8	42.8	15.11	44.0	34.2	15.10	45.8	21.9	15.48
	29.4	45.5	44.2	14.72	46.6	42.8	14.92	48.0	31.8	15.05	43.7	43.7	15.15	45.4	41.6	15.38	46.7	30.9	15.52
	32.2	47.1	46.2	14.75	47.5	43.2	14.95	49.0	39.8	15.09	44.5	44.5	15.19	46.3	42.1	15.42	47.7	38.7	15.56
4800	23.9	43.0	38.0	14.95	45.3	27.1	15.15	46.7	11.4	15.28	42.7	37.8	15.38	44.1	26.4	15.61	45.4	11.1	15.75
	26.7	44.5	42.8	14.99	46.2	34.0	15.19	47.6	21.6	15.32	43.6	41.9	15.42	45.0	33.1	15.65	46.3	21.0	15.79
	29.4	46.1	44.7	15.03	47.1	41.0	15.23	48.6	30.7	15.36	44.5	44.5	15.46	45.9	39.9	15.69	47.2	29.9	15.83
	32.2	47.7	46.7	15.07	48.1	46.2	15.27	49.5	38.4	15.40	45.4	45.4	15.50	46.8	45.0	15.73	48.2	37.3	15.87

Gross Cooling Capacity (kW)																												
Outdoor DB(°C)		40.60									46.10									51.70								
Indoor	WB(°C)	16.10			19.40			22.80			16.10			19.40			22.80			16.10			19.40			22.80		
CFM	DB(°C)	TGC	SHC	PI	TGC	SHC	PI	TGC	SHC	PI	TGC	SHC	PI	TGC	SHC	PI	TGC	SHC	PI	TGC	SHC	PI	TGC	SHC	PI	TGC	SHC	PI
4000	23.9	36.4	29.8	17.07	37.9	21.4	17.31	39.2	9.1	17.46	34.9	28.6	17.26	36.4	20.5	17.52	37.5	8.7	17.77	34.4	28.2	18.43	35.7	20.2	18.79	36.8	8.5	19.04
	26.7	37.1	33.7	17.11	38.7	25.1	17.35	40.0	17.2	17.50	35.6	32.3	17.30	37.1	24.0	17.56	38.3	16.5	17.81	35.1	31.9	18.48	36.4	23.6	18.84	37.5	16.2	19.09
	29.4	37.8	36.4	17.15	39.5	32.3	17.39	40.8	24.3	17.54	36.3	34.9	17.34	37.8	31.0	17.60	39.0	23.2	17.85	35.8	34.5	18.53	37.2	30.5	18.89	38.3	22.8	19.14
	32.2	38.6	37.8	17.20	40.2	36.6	17.44	41.6	30.6	17.59	37.0	36.3	17.39	38.6	35.1	17.65	39.8	29.3	17.90	36.5	35.8	18.57	37.9	34.5	18.93	39.0	28.7	19.19
4300	23.9	37.0	31.1	17.27	38.5	22.3	17.51	39.8	9.4	17.66	35.5	29.8	17.46	37.0	21.4	17.72	38.1	9.0	17.97	35.0	29.5	18.63	36.3	21.0	18.99	37.4	8.8	19.24
	26.7	37.7	34.9	17.31	39.3	27.9	17.55	40.6	17.8	17.70	36.2	33.5	17.50	37.7	26.7	17.76	38.9	17.1	18.01	35.8	33.1	18.68	37.1	26.3	19.04	38.2	16.7	19.29
	29.4	38.5	37.7	17.35	40.1	33.7	17.59	41.4	25.3	17.74	36.9	36.2	17.54	38.5	32.3	17.80	39.7	24.2	18.06	36.5	35.8	18.73	37.8	31.8	19.09	38.9	23.7	19.34
	32.2	39.2	39.2	17.40	40.9	37.9	17.64	42.2	31.5	17.79	37.7	37.7	17.59	39.2	36.3	17.85	40.5	30.2	18.10	37.2	37.2	18.77	38.5	35.7	19.14	39.7	29.6	19.39
4500	23.9	37.5	34.4	16.97	39.0	24.4	17.36	40.3	10.4	17.36	36.0	33.0	17.70	37.5	23.4	17.96	38.6	10.0	18.20	35.5	32.6	18.87	36.8	23.0	19.23	37.9	9.8	19.48
	26.7	38.2	38.2	17.01	39.8	30.6	17.25	41.1	19.7	17.40	36.7	36.7	17.74	38.2	29.4	18.00	39.4	18.9	18.25	36.3	36.3	18.92	37.6	28.9	19.28	38.7	18.5	19.53
	29.4	39.0	39.0	17.05	40.6	37.2	17.29	41.9	27.8	17.44	37.4	37.4	17.78	39.0	35.7	18.05	40.2	26.6	18.30	37.0	37.0	18.97	38.3	35.1	19.33	39.4	26.1	19.58
	32.2	39.7	39.7	17.10	41.4	37.6	17.34	42.8	34.8	17.49	38.2	38.2	17.83	39.7	36.1	18.09	41.0	33.3	18.34	37.7	37.7	19.01	39.1	35.5	19.38	40.2	32.7	19.63
4800	23.9	37.9	33.6	17.82	39.5	23.7	18.05	40.8	10.0	18.20	36.5	32.3	18.00	37.9	22.7	18.26	39.1	9.6	18.51	36.0	31.9	19.18	37.3	22.3	19.54	38.4	9.4	19.79
	26.7	38.7	37.2	17.86	40.3	29.6	18.10	41.6	18.9	18.25	37.2	35.8	18.05	38.7	28.5	18.31	39.9	18.1	18.56	36.8	35.3	19.23	38.1	28.0	19.59	39.2	17.8	19.84
	29.4	39.5	39.5	17.90	41.1	35.7	18.15	42.4	26.9	18.30	37.9	37.9	18.10	39.5	34.3	18.36	40.7	25.8	18.61	37.5	37.5	19.28	38.8	33.7	19.64	39.9	25.3	19.89
	32.2	40.3	40.3	17.95	41.9	40.3	18.19	43.3	33.6	18.34	38.7	38.7	18.14	40.3	38.7	18.40	41.5	32.2	18.65	38.2	38.2	19.33	39.6	38.1	19.69	40.7	31.6	19.94

Notes:

1. DB = Dry Bulb Temperature (°C), WB = Wet Bulb Temperature (°C)
4. TGC = Total Cooling Capacity (kW)
5. SHC = Sensible Heating Capacity (kW)
6. PI = Power Input (kW)

8. Air flow rate- Static pressure curve

MTA-76 (H) CRN1

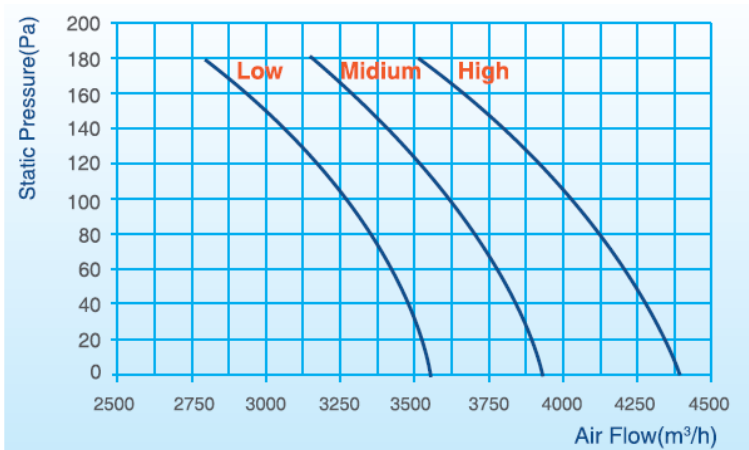

MTA-96 (H) CRN1

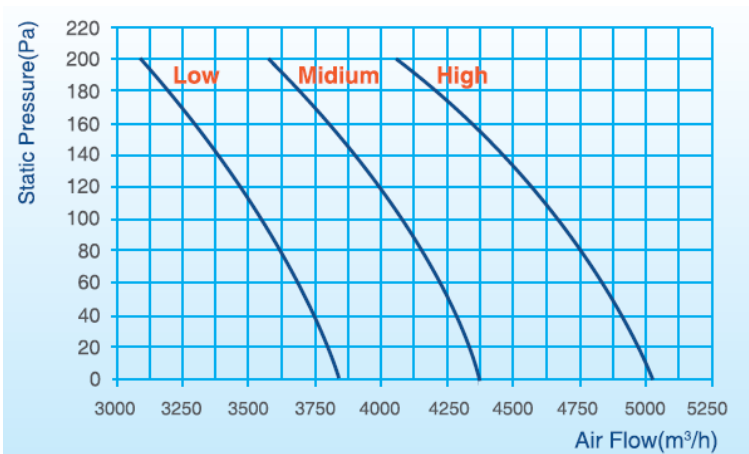

MTA-120 (H) CRN1

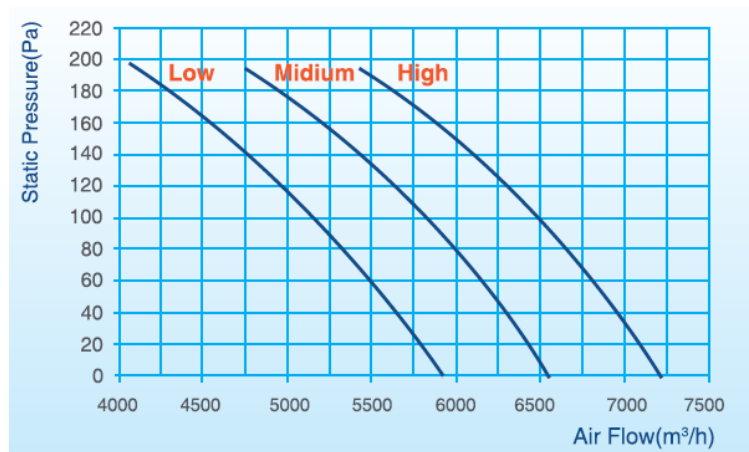

MTA-150 (H) CRN1

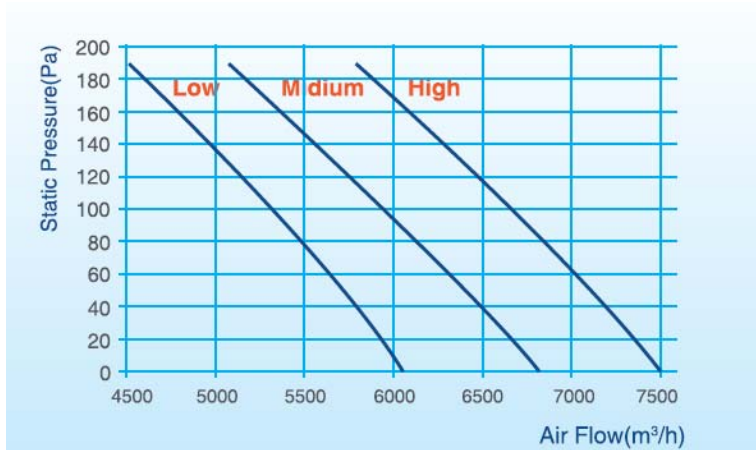

MHB-76 (H) CRN1

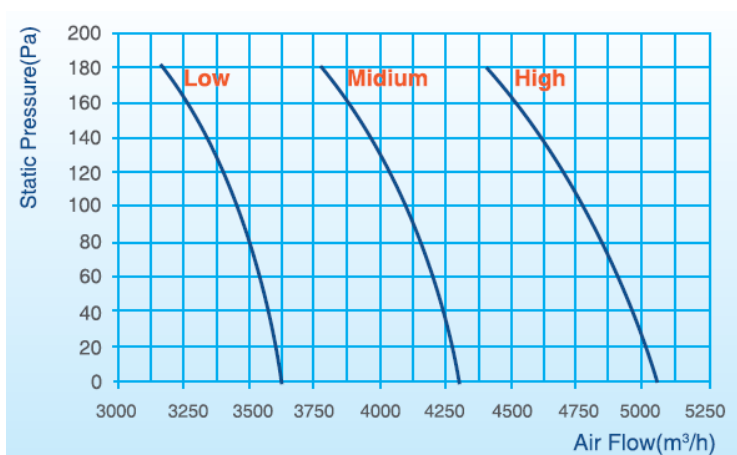

MHB-96 (H) CRN1

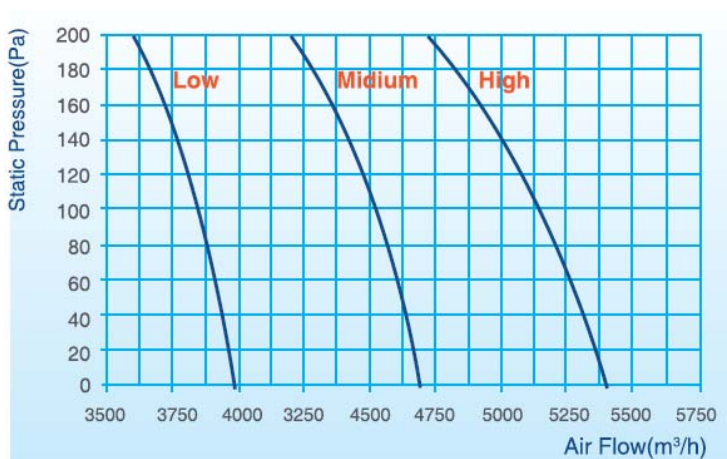

9. Electric Characteristics

Model	Indoor Unit				Power Supply		IFM	
	Hz	Voltage	Min.	Max.	MCA	MFA	kW	FLA
MTA-76CRN1	50	220-240	198	254	7.53	15	1.341	6.02
MTA-76HRN1	50	220-240	198	254	7.53	15	1.341	6.02
MTA-96CRN1	50	220-240	198	254	9.1	15	1.605	7.28
MTA-96HRN1	50	220-240	198	254	9.1	15	1.605	7.28
MTA-120CRN1	50	220-240	198	254	11.19	20	2.03	8.95
MTA-120HRN1	50	220-240	198	254	11.19	20	2.03	8.95
MTA-150CRN1	50	220-240	198	254	16.5	15	2.7	13.2
MTA-150HRN1	50	220-240	198	254	16.5	15	2.7	13.2
MHB-76CRN1	50	220-240	198	254	9.51	15	1.652	7.61
MHB-76HRN1	50	220-240	198	254	9.51	15	1.652	7.61
MHB-96CRN1	50	220-240	198	254	11.21	-	2.005	8.97
MHB-96HRN1	50	220-240	198	254	11.21	-	2.005	8.97

Note:

MCA: Min. Current Amps. (A)

MFA: Max. Fuse Amps. (A)

IFM: Indoor Fan Motor

kW: Fan Motor Rated Output (kW)

FLA: Full Load Amps. (A)

Model	Outdoor Unit				Power Supply			Compressor		OFM	
	Hz	Voltage	Min.	Max.	MCA	TOCA	MFA	MSC	RLA	KW	FLA
MOV-76CN1-C	50	380-415	342	438	17.5	18	27	48*2	6.3*2	0.573	2.613
MOV-76HN1-C	50	380-415	342	438	17.5	18	27	48*2	6.3*2	0.573	2.613
MOV-96CN1-C	50	380-415	342	438	20	21	31.5	53*2	8*2	1.373	6.26
MOV-96HN1-C	50	380-415	342	438	20	21	31.5	53*2	8*2	1.373	6.26
MOV-120CN1-C	50	380-400	342	440	25	28.6	30	147	21.4	1.373	6.26
MOV-120HN1-C	50	380-400	342	440	25	28.6	30	147	21.4	1.373	6.26

Note:

MCA: Min. Current Amps. (A)

MFA: Max. Fuse Amps. (A)

RLA: Rated Locked Amps. (A)

KW: Rated Motor Output (KW)

TOCA: Total Over-current Amps. (A)

MSC: Max. Starting Amps. (A)

OFM: Outdoor Fan Motor

FLA: Full Load Amps. (A)

10. Sound Levels

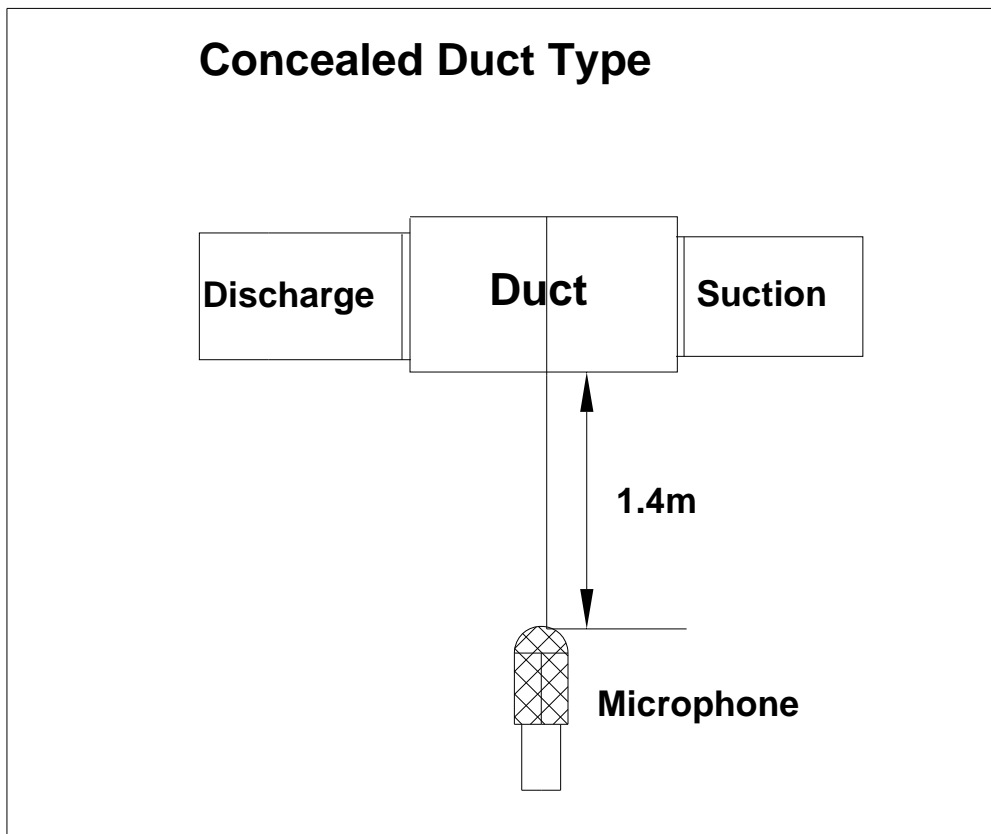

Unit Number	Model	Noise level under three speeds of fan (dB(A))
1	MTA-76C(H)RN1	54
2	MTA-96C(H)RN1	55
3	MTA-120C(H)RN1	56
4	MTA-150C(H)RN1	56
5	MHB-76C(H)RN1	54
6	MHB-96C(H)RN1	55

11. Troubleshooting

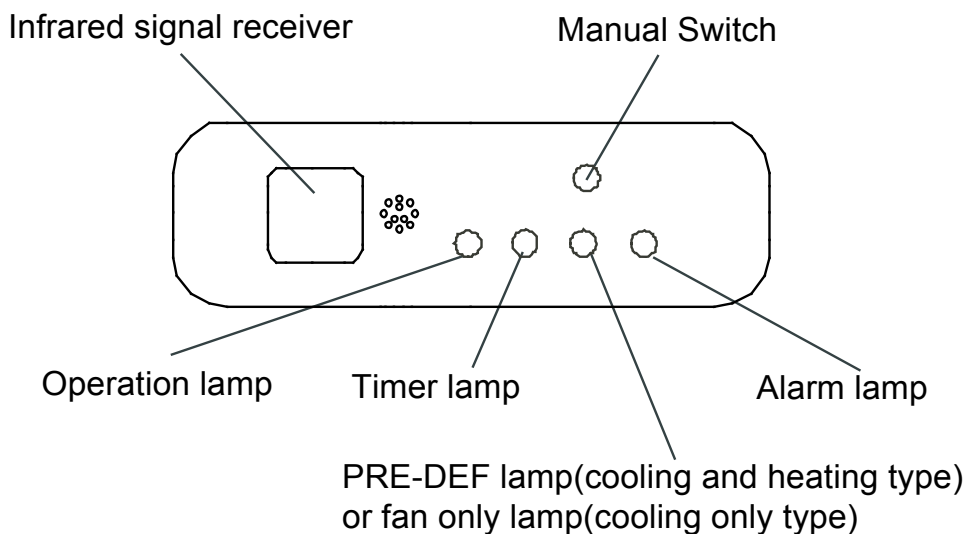

Type	OPT. Light	TME. Light	DEF. Light	ALARM Light	Remarks
Room temp. sensor error	-	☆	-	-	Manual reset
Evaporator temp. sensor error	☆	-	-	-	Manual reset
Condenser temp. sensor error	-	-	☆	-	Manual reset
Water pump temp. sensor error	☆	-	-	☆	Manual reset
The PRO terminal on PCB of indoor unit without connected to grounding wire	☆	☆	☆	☆	Manual reset
EEPROM error	☆	☆	-	-	Manual reset
Condensing water level full error	-	-	-	☆	Manual reset

Note:

OPT. Light: operation light; TME. Light: timer light;
DEF. Light: defrosting light; ☆: the light flashing.

11.1 Malfunctions of air conditioner

If any of the following malfunctions occur, stop operation of the air conditioner immediately. Turn off the power switch, and contact the local after sales service center of manufacturer:

- The RUN lamp flashes quickly (2 flash per second).
- After turning off the power switch and then turning it on again, the RUN lamp still flashes quickly.
- The receiving function of the remote controller fails, or the start/ shutdown operation is abnormal.
- The fuse blows out frequently, or the circuit breaker protection occurs frequently.
- Obstacles or water enter the air conditioner.
- Condensing water leaks from indoor unit.
- Other malfunctions occur.

If the air conditioner fails and does not meet the above phenomena, check the system as the following table:

Symptoms	Causes	Handling methods
The unit does not work	Power supply fails.	Operate after power resumes.
	Power switch is not connected.	Connect the power supply properly.
	Fuse blows out or circuit breaker snaps off.	Replace the fuse or check whether electric leakage occurs.
	The remote controller or the wire controller fails.	Check the remote controller or wire controller.
Air flowing normally but completely can't cooling	Temperature setting is improper.	Temperature setting is higher than the room temperature in cooling mode. Or temperature setting is lower than the room temperature in heating mode.
	3-minute protection of compressor.	Waiting for 3 minutes.
The unit starts or stops frequently	The system is lack of refrigerant. Or there is too much refrigerant in the system.	Fix the leakage places, and charge the proper quantity of refrigerant.
	Air or non-condensable gas exists in the refrigerant system.	Vacuum the system and charge refrigerant again.
	Compressor fails.	Repair or replace the compressor.
	The voltage is too high or too low.	Install a voltage regulator.
	The refrigerant pipe is obstructed.	Locate and replace that part.
Poor cooling effect	The heat exchanger of outdoor unit or indoor unit is too dirty.	Clean the heat exchanger.
	The filter is too dirty.	Clean the filter.
	Air inlet or air outlet of the indoor/ outdoor unit is blocked.	Remove obstacles to keep well ventilating.
	Doors or windows of the room are open.	Close all the windows and doors.
	Directly exposed to sunlight.	Use curtain to obstruct sunlight.
	Too many heat sources in the room.	Reduce the heat sources.
	The outdoor ambient temperature is too high.	The cooling effect is poor but normal.
	The system is lack of refrigerant.	Fix the leakage places, and charge the proper quantity of refrigerant.
Poor heating effect	The outdoor ambient temperature is lower than -7℃.	Use an assistance heating device.
	Doors or windows of the room are not closed tightly.	Close the doors and windows properly.
	The system is lack of refrigerant.	Fix the leakage places, and charge the proper quantity of refrigerant.

Symptoms	Causes	Handling methods
The fan speed cannot be changed	Check whether the mode marked on the screen is "AUTO".	When the "AUTO" mode is selected, the unit will change the fan speed automatically.
	Check whether the mode marked on the screen is "DEWET".	When the "DEWET" mode is selected, the unit will change the fan speed automatically. The fan speed can be selected in "COOLING", "HEATING" and "SUPPLY AIR" mode.
The "ON/OFF" button of remote controller do not work	Check whether the batteries of remote controller are exhausted.	Replace the batteries.
The "ON/OFF" lamp extinguishes	Check whether the time set on the timer has expired.	Restart the unit.
The "TIMER ON" lamp extinguishes	Check whether the time set on the timer has expired.	It comes to the setting time and the unit stat running automatically.
No receiving sounds from the indoor unit even when the "ON/OFF" button is pressed	Check whether the signal transmitter of the remote controller is properly directed to the infrared signal receiver of the indoor unit when the "ON/OFF" button is pressed.	Directly transmit the signal transmitter of the remote controller to the infrared signal receiver of the indoor unit, and then push the "ON/OFF" button twice.
The buttons of the remote controller do not work	Check whether the settings are locked.	Push the "LOCK" button again.

Operation lamp flashes:

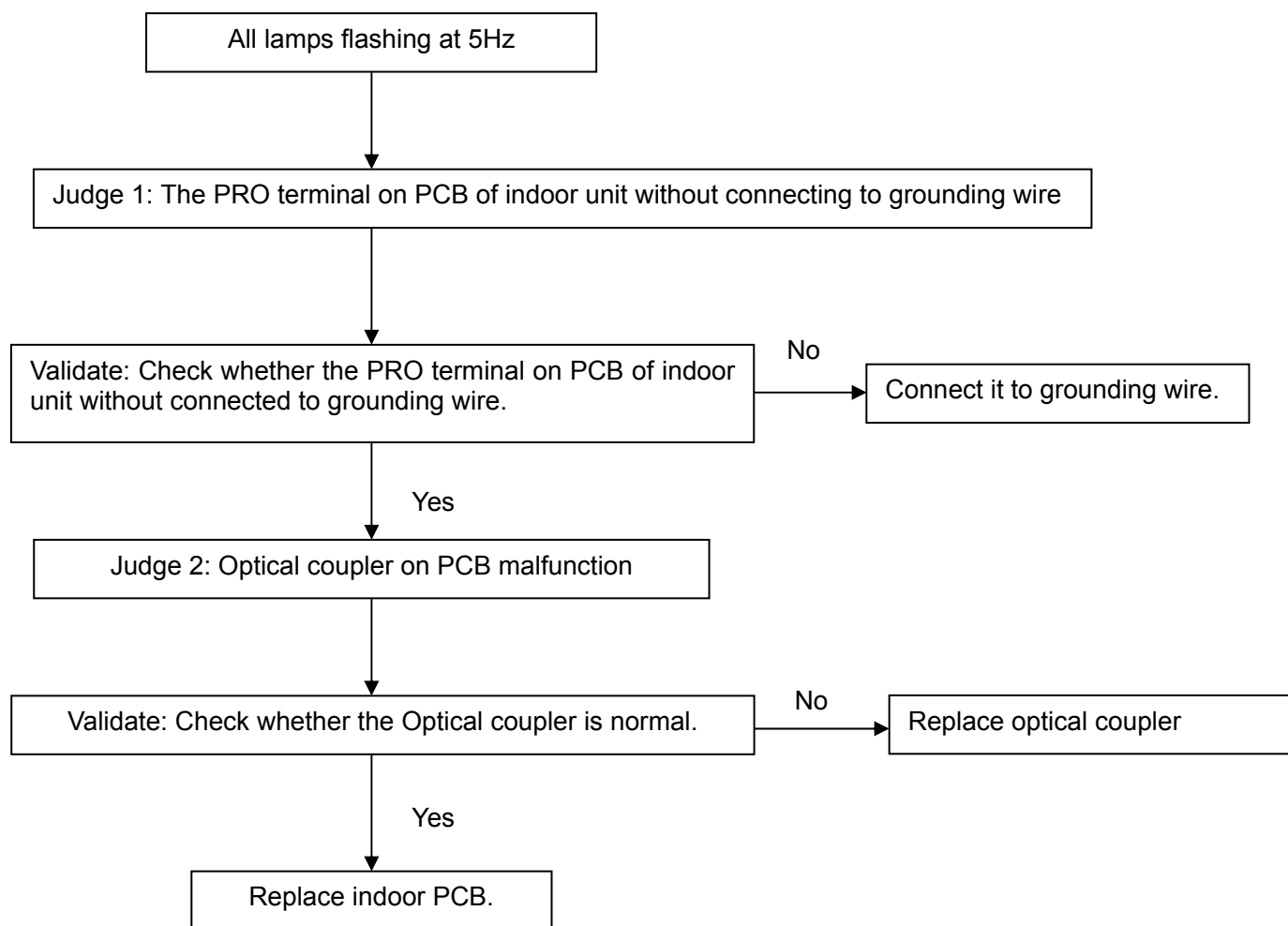

Operation lamp flashes:

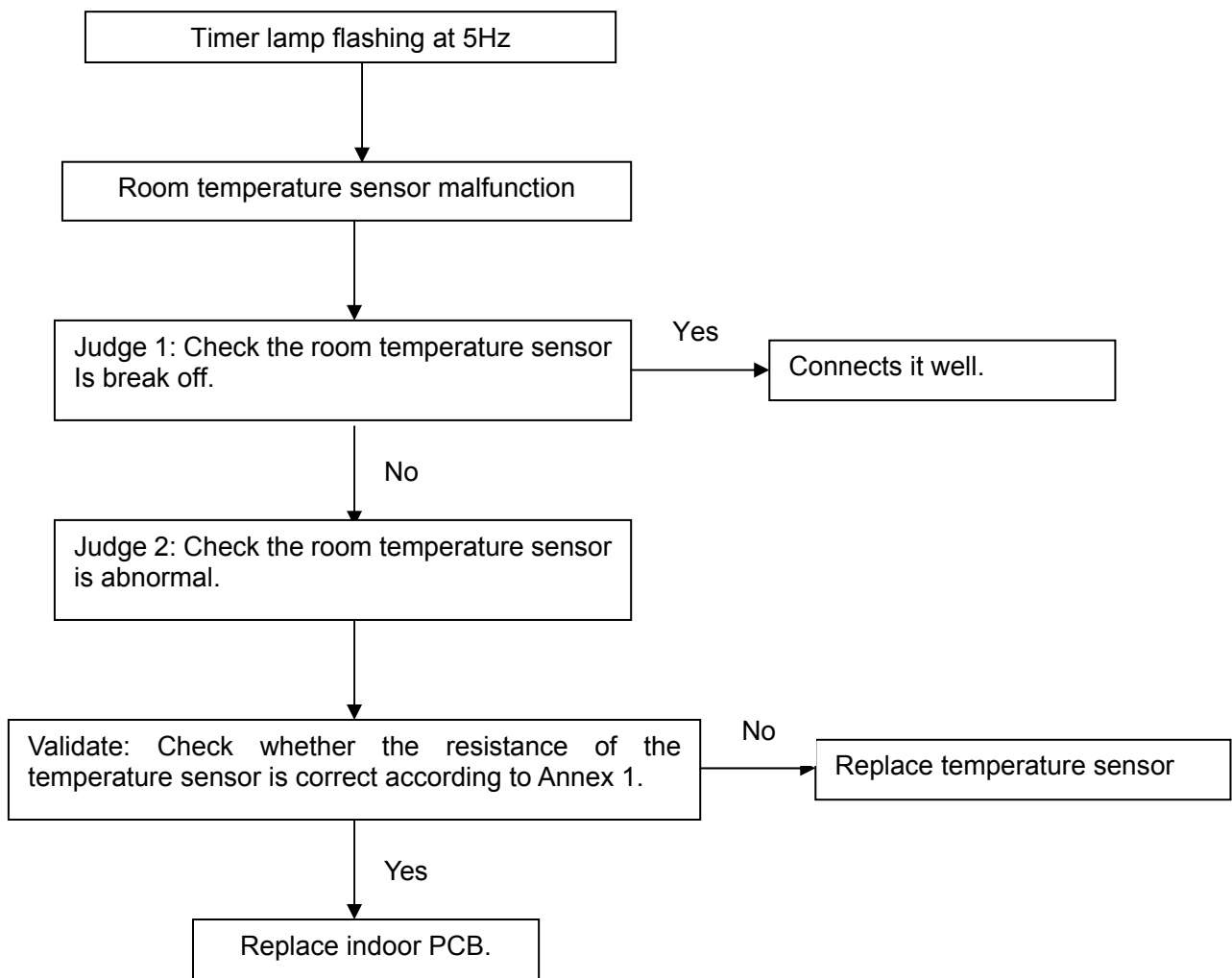

Operation lamp flashes:

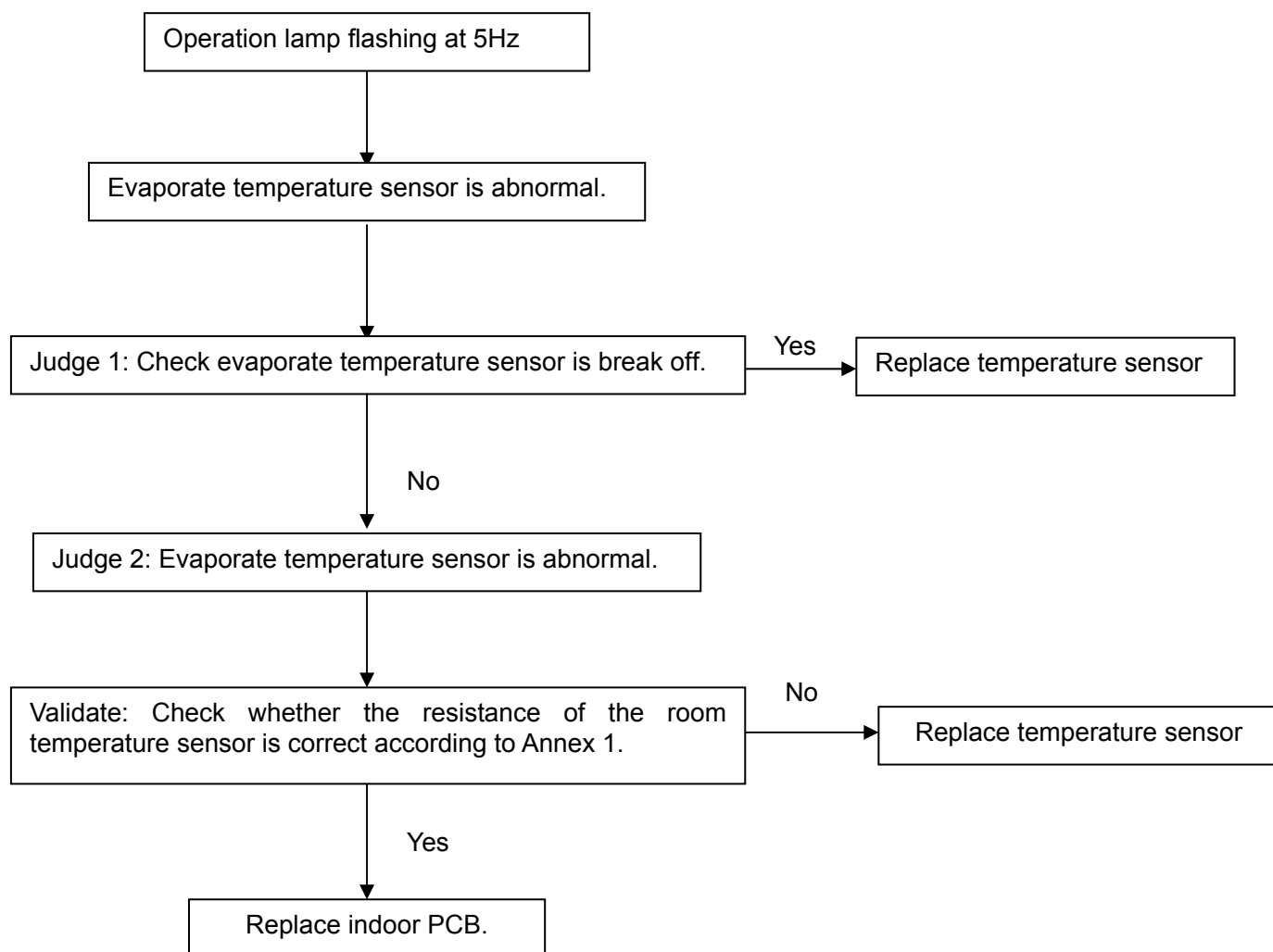

Operation lamp flashes:

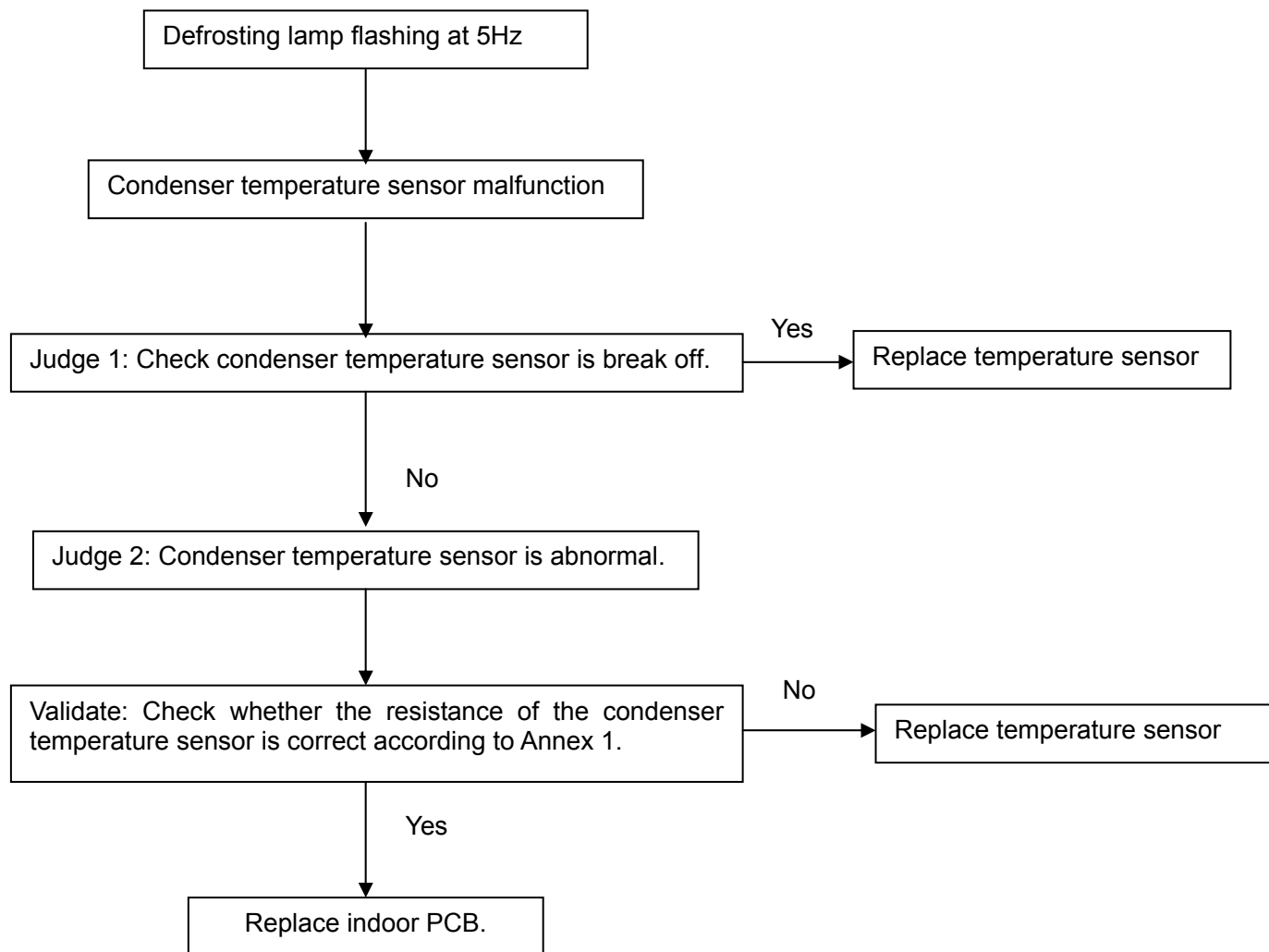

Part 3 Outdoor Units

1. Specifications	45
2. Dimension	47
3. Service Space	48
4. Wiring Diagrams	50
5. Electric Characteristics	52
6. Operation Limits	53
7. Sound Levels	54
8. Troubleshooting	55

1. Specifications

Model		MOV-76CN1-C	MOV-76HN1-C	MOV-96CN1-C	MOV-96HN1-C	
Power supply	-	380~415V-3N-50Hz		380~415V-3N-50Hz		
Ambient temp range	°C	17~52	-7~52	17~52	-7~52	
Rated input	W	11700	11700	14400	14400	
Rated current	A	19.3	19.3	23.7	23.7	
Noise level	dB(A)	65	65	67	67	
Compressor	Type	-	scroll	scroll	scroll	
	Qty.	-	1	1	1	
	Capacity	Btu/h	74500	74500	100000	100000
	Input	W	6950	6950	9110	9110
	Rated current (RLA)	A	12.3	12.3	16.6	16.6
	Locked rotor Amp (LRA)	A	110	110	110	110
Refrigerant	Type	-	R410A	R410A	R410A	
	Charge	g	5400	5400	6000	6000
Fan	Type	-	Axial fan	Axial fan	Axial fan	
	Dimension	mm	Φ530	Φ530	Φ530	Φ530
	Drive type/ motor step	-	Direct/ Single	Direct/ Single	Direct/ Single	Direct/ Single
	Motor input	W	310+292	310+292	670+644	670+644
	Motor speed	rpm	928/942	928/942	1250/1220	1250/1220
Coil	Type	-	Copper tube and aluminum fin		Copper tube and aluminum fin	
	Tube size	mm	Φ7.94	Φ7.94	Φ7	Φ7
	No. of rows	-	2	2	3	3
	Fin per inch	FPI	18	18	19	19
	Length * height	mm	2185*880	2185*880	2179*882	2179*882
Refrigerant piping	Liquid side/ Gas side	mm	Φ9.52/Φ22	Φ9.52/Φ22	Φ9.52/Φ25	Φ9.52/Φ25
	Max. pipe length	m	50	50	50	50
	Max. difference in level	m	30	30	30	30
Connection wiring	Power wiring	mm ²	5×6.0	5×6.0	5×6.0	5×6.0
	Signal wiring	mm ²	2×1.0	4×1.0	2×1.0	4×1.0
Dimension (W*H*D)	mm	1255*700*908	1255*700*908	1255*700*908	1255*700*908	
Packing (W*H*D)	mm	1320*730*1060	1320*730*1060	1320*730*1060	1320*730*1060	
Net/ Gross weight	kg	171/190	174/193	185/202	187/204	
Shipping Qty per 20'/40'/40'HD	pcs	24/54/54	24/54/54	24/54/54	24/54/54	

Notes:

1. Nominal cooling capacities are based on the following conditions:

Indoor temp: 27°CDB, 19°CWB; Outdoor temp: 35°CDB; Equivalent refrigerant piping: 7.5m (horizontal)

2. Nominal heating capacities are based on the following conditions:

Indoor temp: 20°CDB; Outdoor temp: 7°CDB, 6°CWB; Equivalent ref. piping: 7.5m (horizontal)

Model			MOV-120CN1-C	MOV-120HN1-C
Power supply		-	380~400V-3N-50Hz	
Ambient temp range		°C	17~52	-7~52
Rated input		W	17300	17300
Rated current		A	28.6	28.6
Noise level		dB(A)	69	69
Compressor	Type	-	scroll	scroll
	Qty.	-	1	1
	Capacity	Btu/h	118000	118000
	Input	W	10862	10862
	Rated current (RLA)	A	21.4	21.4
	Locked rotor Amp (LRA)	A	147	147
Refrigerant	Type	-	R410A	R410A
	Charge	g	7200	7200
Fan	Type	-	Axial fan	Axial fan
	Dimension	mm	Φ530	Φ531
	Drive type/ motor step	-	Direct/ Single	Direct/ Single
	Motor input	W	621+587	621+587
	Motor speed	rpm	1230/1180	1230/1180
Coil	Type	-	Copper tube and aluminum fin	
	Tube size	mm	Φ7	Φ7
	No. of rows		3	3
	Fin per inch	FPI	19	19
	Length * height	mm	1376*880	1376*880
Refrigerant piping	Liquid side/ Gas side	mm	Φ12.7 / Φ28.6	Φ12.7 / Φ28.6
	Max. pipe length	m	50	50
	Max. difference in level	m	30	30
Connection wiring	Power wiring	mm ²	5*6.0	5*6.0
	Signal wiring	mm ²	2*1.0	4*1.0
Dimension (W*H*D)		mm	1255*908*700	1255*908*700
Packing (W*H*D)		mm	1295*1025*700	1295*1025*700
Net/ Gross weight		kg	199/215	201/217
Shipping Qty per 20'/40'/40'HD		pcs	24/54/54	24/54/54

Notes:

- Nominal cooling capacities are based on the following conditions:
Indoor temp: 27°CDB, 19°CWB; Outdoor temp: 35°CDB; Equivalent refrigerant piping: 7.5m (horizontal)
- Nominal heating capacities are based on the following conditions:
Indoor temp: 20°CDB; Outdoor temp: 7°CDB, 6°CWB; Equivalent ref. piping: 7.5m (horizontal)

2. Dimension

2.1 MOV-76CN1-C, MOV-76HN1-C, MOV-96CN1-C, MOV-96HN1-C MOV-120HN1-C, MOV-120CN1-C

Unit: mm

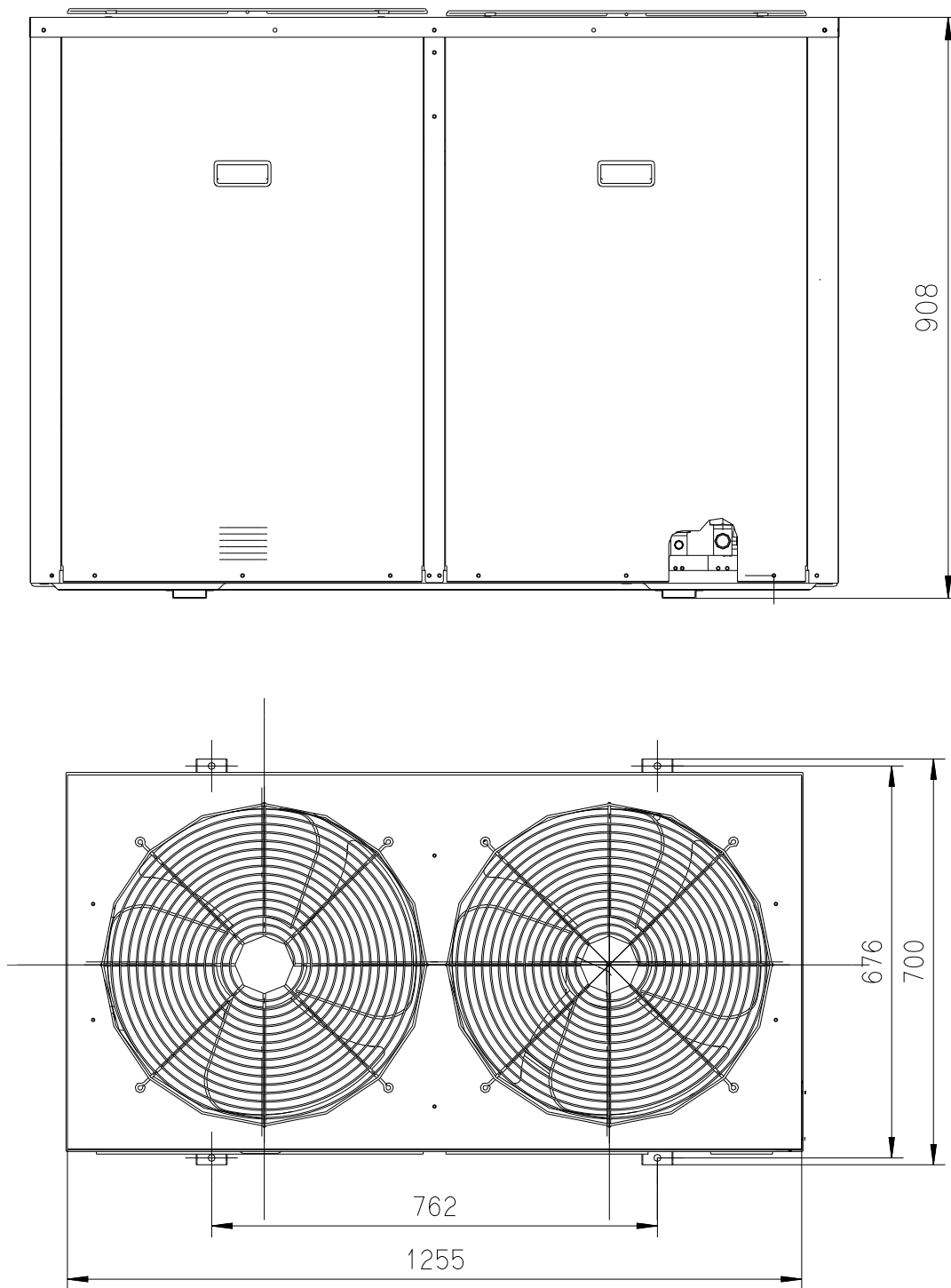

3. Service Space

3.1 MOV-76CN1-C, MOV-76HN1-C, MOV-96CN1-C, MOV-96HN1-C MOV-120HN1-C, MOV-120CN1-C

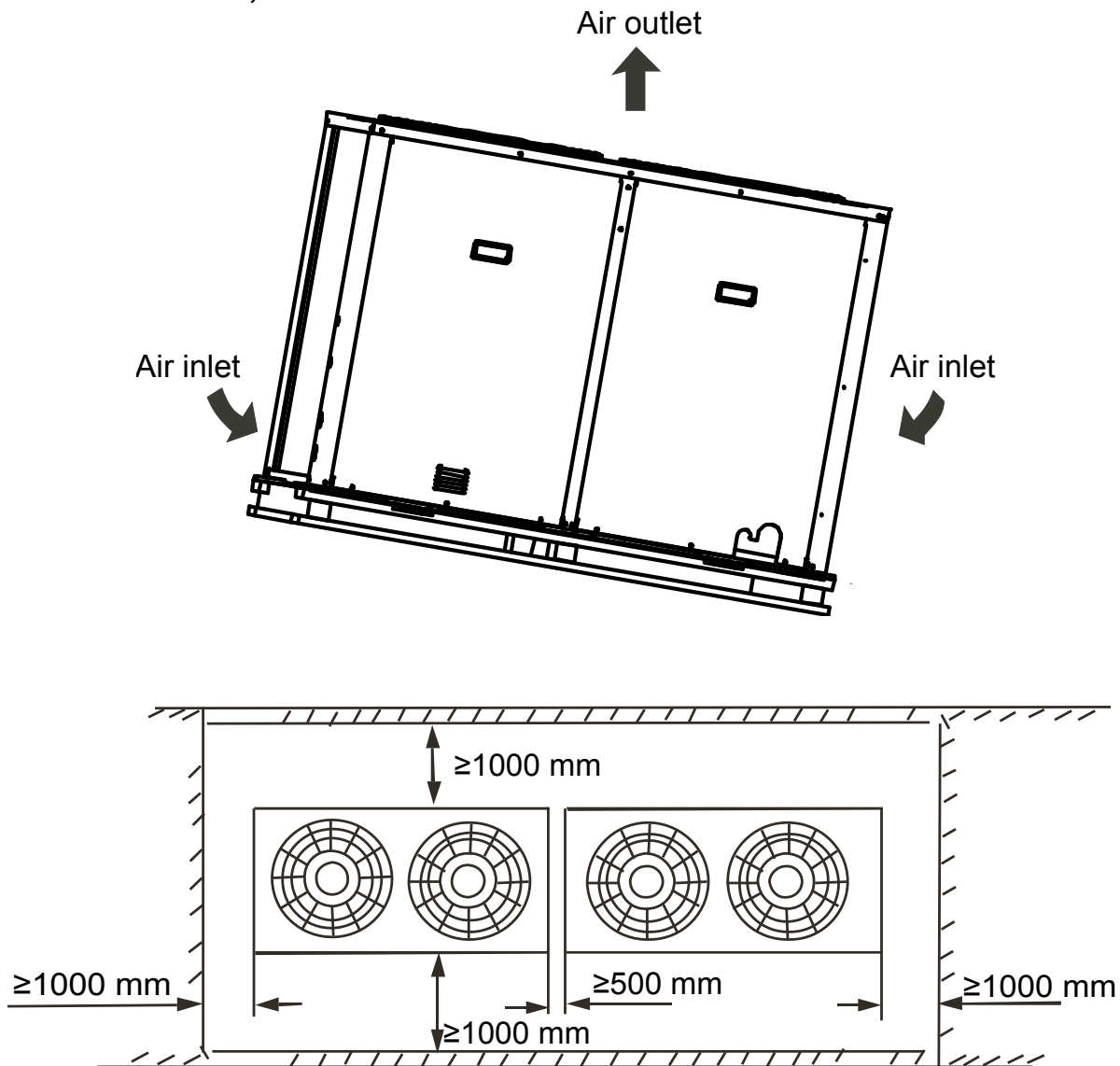

Note:

1. In case any obstacles exist above the outdoor unit, such obstacles must be 2000mm above the outdoor unit.
2. If miscellaneous articles are piled around the outdoor unit, such articles must be 400mm below the top of the outdoor unit.

Foundation of the outdoor unit

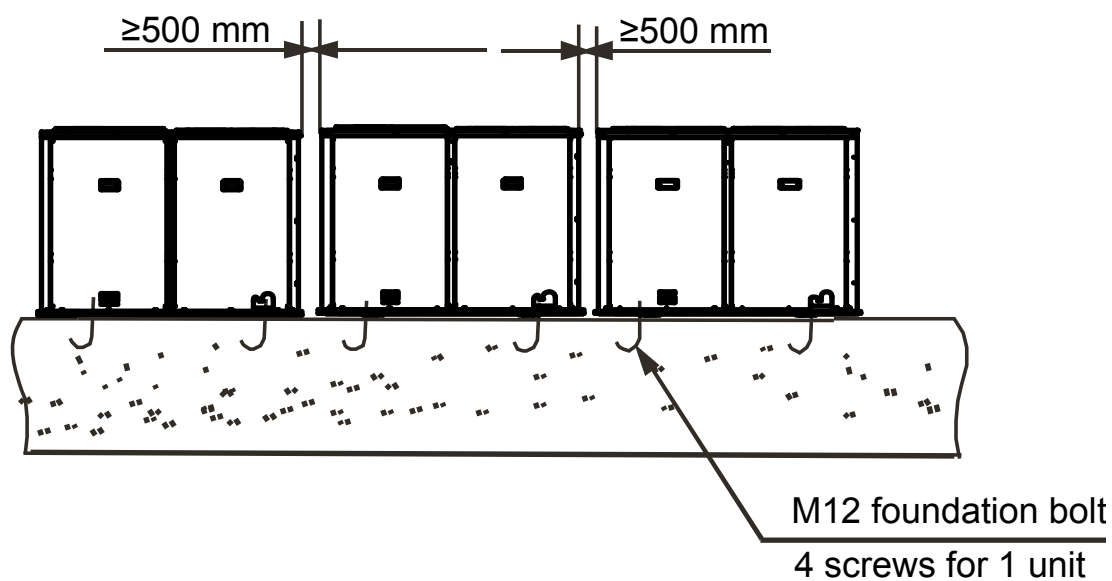
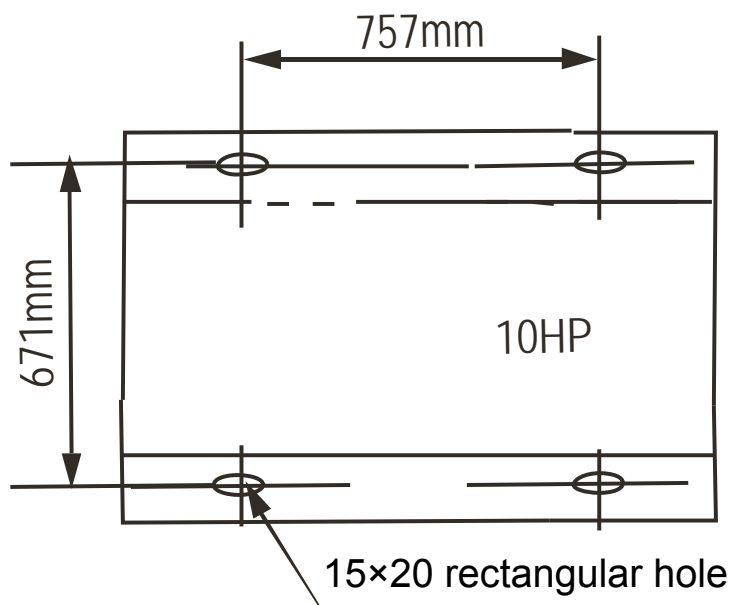

4. Wiring Diagrams

4.1 MOV-76CN1-C, MOV-96CN1-C, MOV-120CN1-C

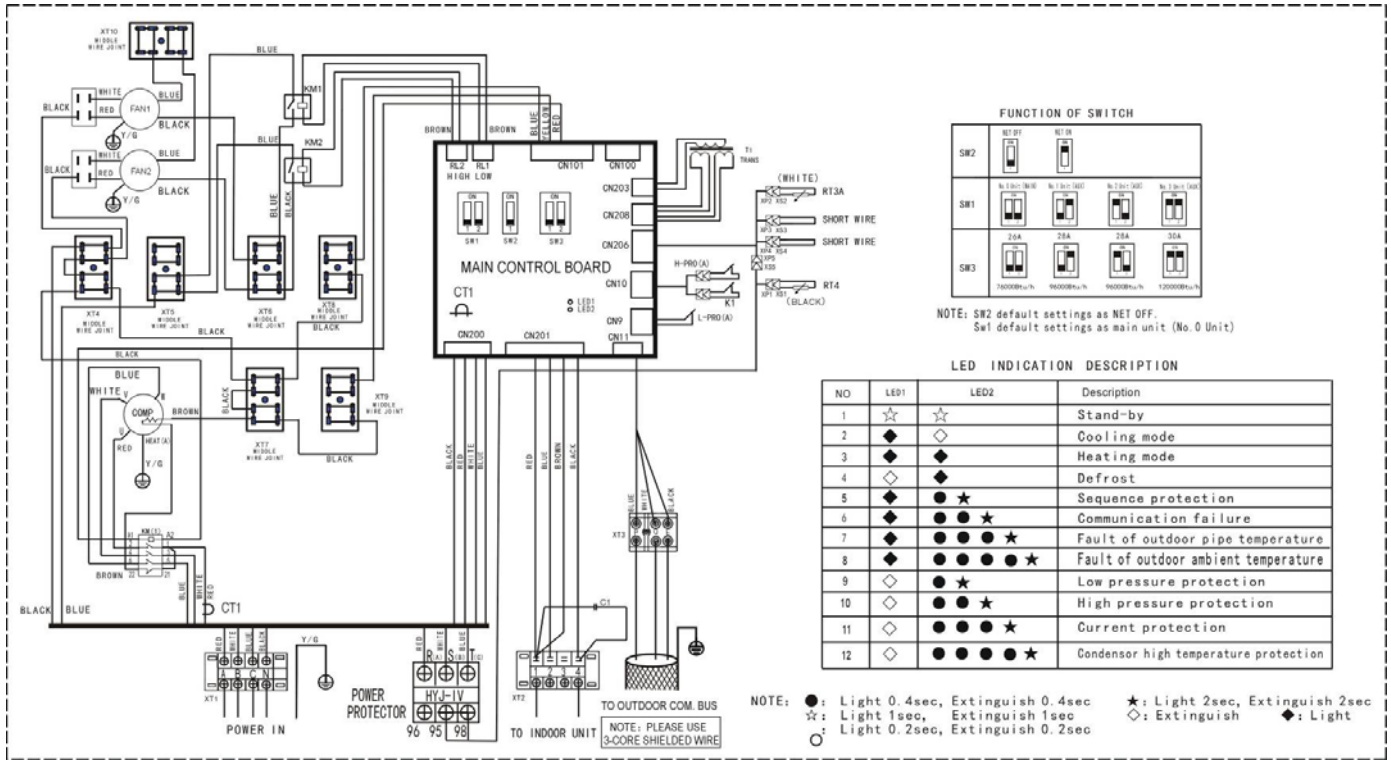

Item	Name	Item	Name	Item	Name	Item	Name
COMP	Compressor	HEAT(A)	Crank	RT3A	Pipe sensor temp.	T1	Transformer
FAN1-2	Outdoor fan	CT1	Current detector	RT4	Room sensor	SW1-3	Switch
CAP1-2	Fan capacitance	XT1-2	4-way terminal	XS1-5, XP1-5	Connectors	C1	Filter capacitor
S.V	4-way valve	XT3	3-way terminal	L-PRO(A)	Low pressure switch	KM1-2	Relay
KM(1)	AC contactor	H-PRO(A)	High pressure switch	K1	Temp. protect switch	CN8-208	P.C. board socket
XT4-10	Middle wire joint	-	-	-	-	-	-

4.2 MOV-76HN1-C, MOV-96HN1-C, MOV-120HN1-C

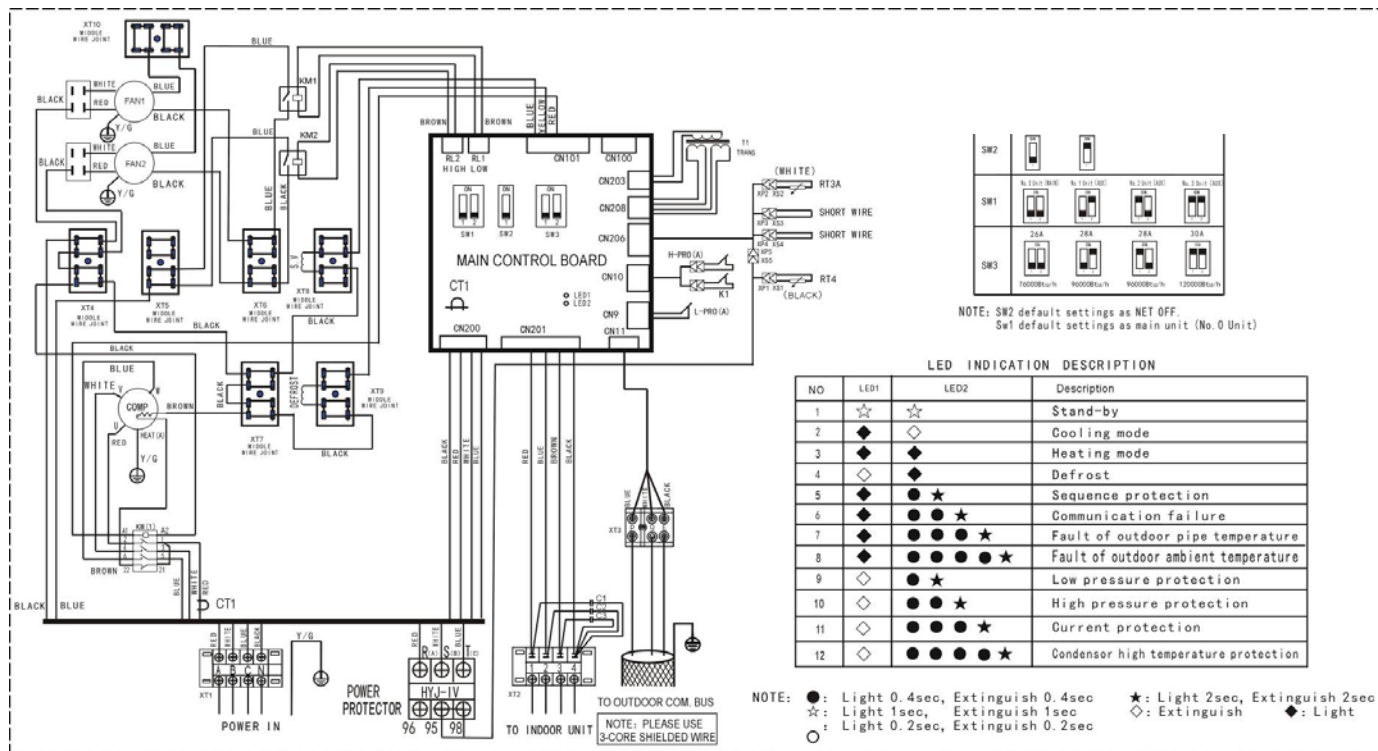

Item	Name	Item	Name	Item	Name	Item	Name
COMP	Compressor	HEAT(A)	Crank	RT3A	Pipe sensor temp.	T1	Transformer
FAN1-2	Outdoor fan	CT1	Current detector	RT4	Room sensor	SW1-3	Switch
CAP1-2	Fan capacitance	XT1-2	4-way terminal	XS1-5, XP1-5	Connectors	C1-3	Filter capacitor
S.V	4-way valve	XT3	3-way terminal	L-PRO(A)	Low pressure switch	KM1-2	Relay
KM(1)	AC contactor	H-PRO(A)	High pressure switch	K1	Temp. protect switch	CN8-208	P.C. board socket
XT4-10	Middle wire joint	-	-	-	-	-	-

5. Electric Characteristics

Model	Outdoor Unit				Power Supply			Compressor		OFM	
	Hz	Voltage	Min.	Max.	MCA	TOCA	MFA	MSC	RLA	KW	FLA
MOV-76C-C	50	380-415V	342V	438V	17.5	18	27	48*2	6.3*2	0.573	2.613
MOV-76H-C	50	380-415V	342V	438V	17.5	18	27	48*2	6.3*2	0.573	2.613
MOV-96C-C	50	380-415V	342V	438V	20	21	31.5	53*2	8*2	1.373	6.26
MOV-96H-C	50	380-415V	342V	438V	20	21	31.5	53*2	8*2	1.373	6.26
MOV-120C-C	50	380-400V	342V	440V	25	28.6	30	147	21.4	1.373	6.26
MOV-120H-C	50	380-400V	342V	440V	25	28.6	30	147	21.4	1.373	6.26

Remark:

MCA: Min. Current Amps. (A)

TOCA: Total Over-current Amps. (A)

MFA: Max. Fuse Amps. (A)

MSC: Max. Starting Amps. (A)

RLA: Rated Locked Amps. (A)

OFM: Outdoor Fan Motor.

FLA: Full Load Amps. (A)

KW: Rated Motor Output (kW)

6. Operation Limits

Temperature range for unit operation:

Model \ Item	Cooling mode		Heating mode	
	Outdoor	Indoor	Outdoor	Indoor
All model	17°C~52°C	≥17°C	-7°C~24°C	≤30°C

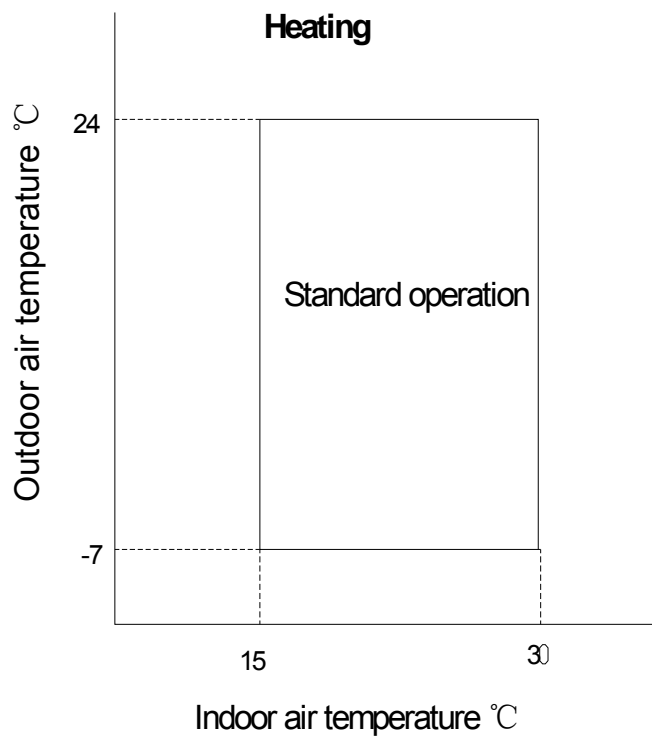
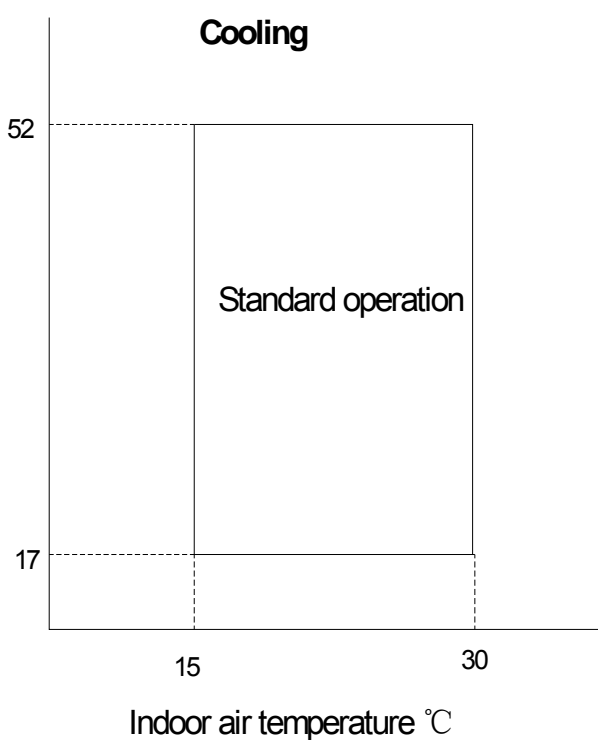

7. Sound Levels

Standard of testing

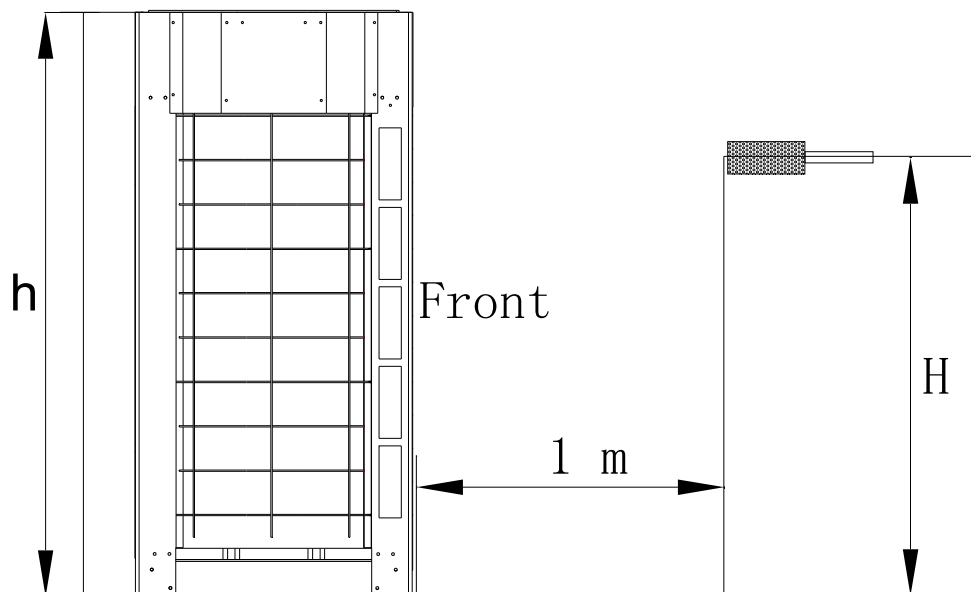

Note: $H = (h+1) / 2$

Unit Number	Model	Noise level (dB(A))
1	MOV-76C(H)N1-C	63
2	MOV-96C(H)N1-C	64
3	MOV-120C(H)N1-C	65

8. Troubleshooting

Type	LED1	LED2	Remarks
Standby	☆	☆	-
Cooling mode	◆	◇	-
Heating mode	◆	◆	-
Defrosting mode	◇	◆	-
Phase sequence protection	◆	●★	Manual reset
Communication failure	◆	●●★	Manual reset
Outdoor condenser temp. sensor error	◆	●●●★	Manual reset
Outdoor ambient temp. sensor error	◆	●●●●★	Manual reset
Protection of low pressure	◇	●★	Auto reset
Protection of high pressure	◇	●●★	Auto reset
Protection of over-current	◇	●●●★	Auto reset
Protection of condenser hi-temp.	◇	●●●●★	Auto reset

Note:

☆: Light for 1 second, extinguish for 1 second;

◆: Light;

◇: Extinguish;

●: Light for 0.4 second, extinguish for 0.4 second;

★: Light for 2 second, extinguish for 2 second.

Malfunions:

About the Fault of T3A or T3B, High pressure protection, low pressure protection.
Please refer to the following:

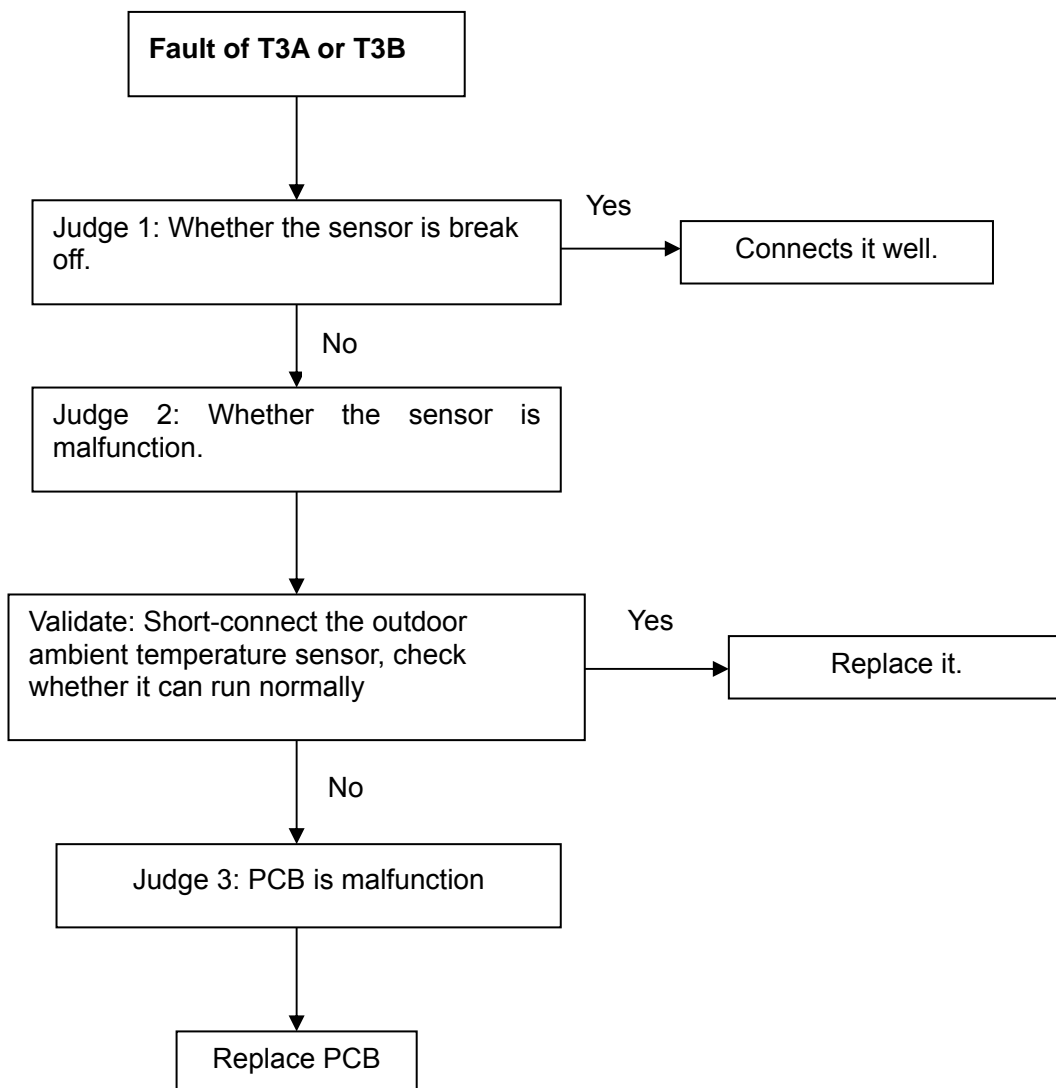

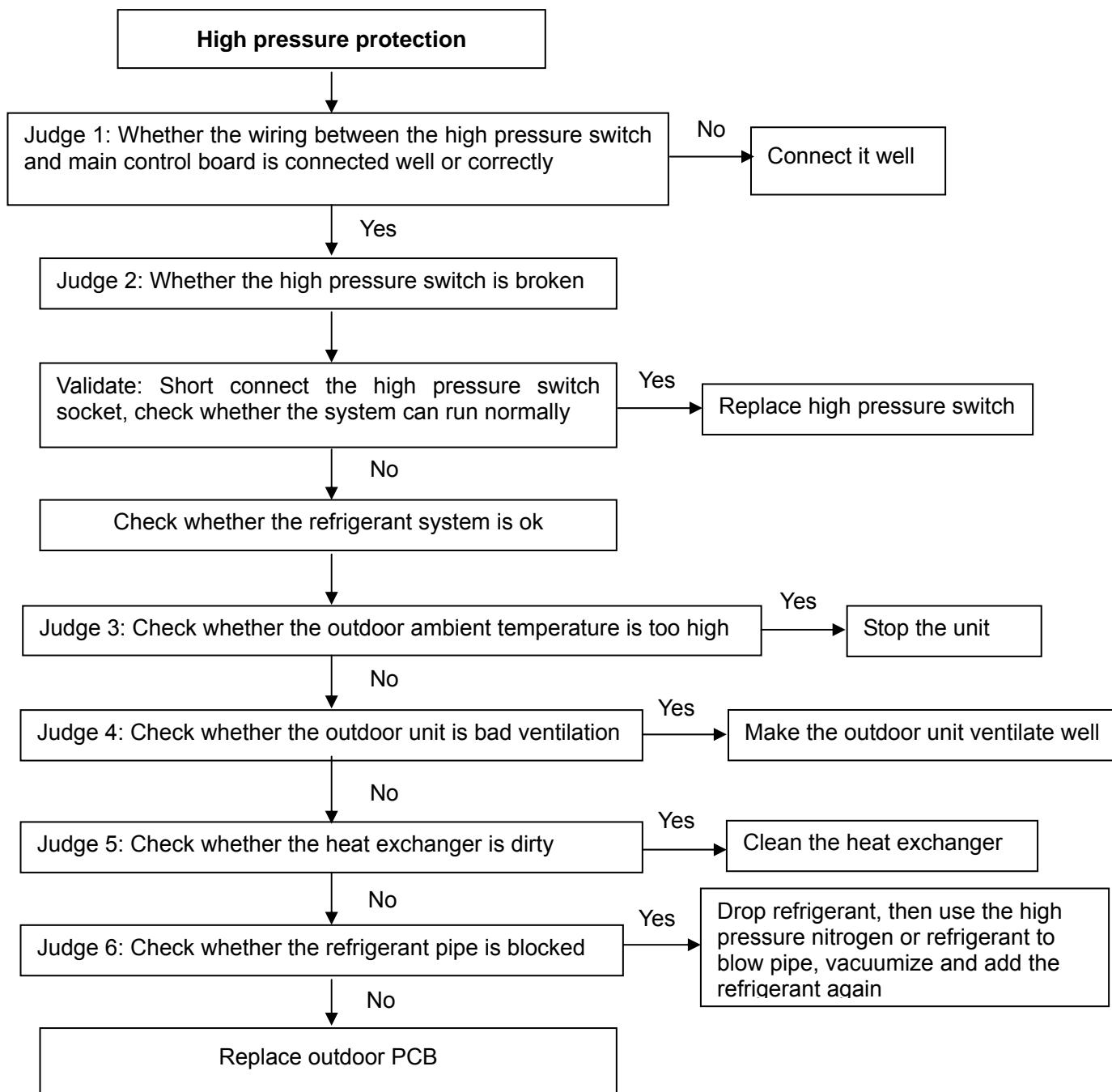

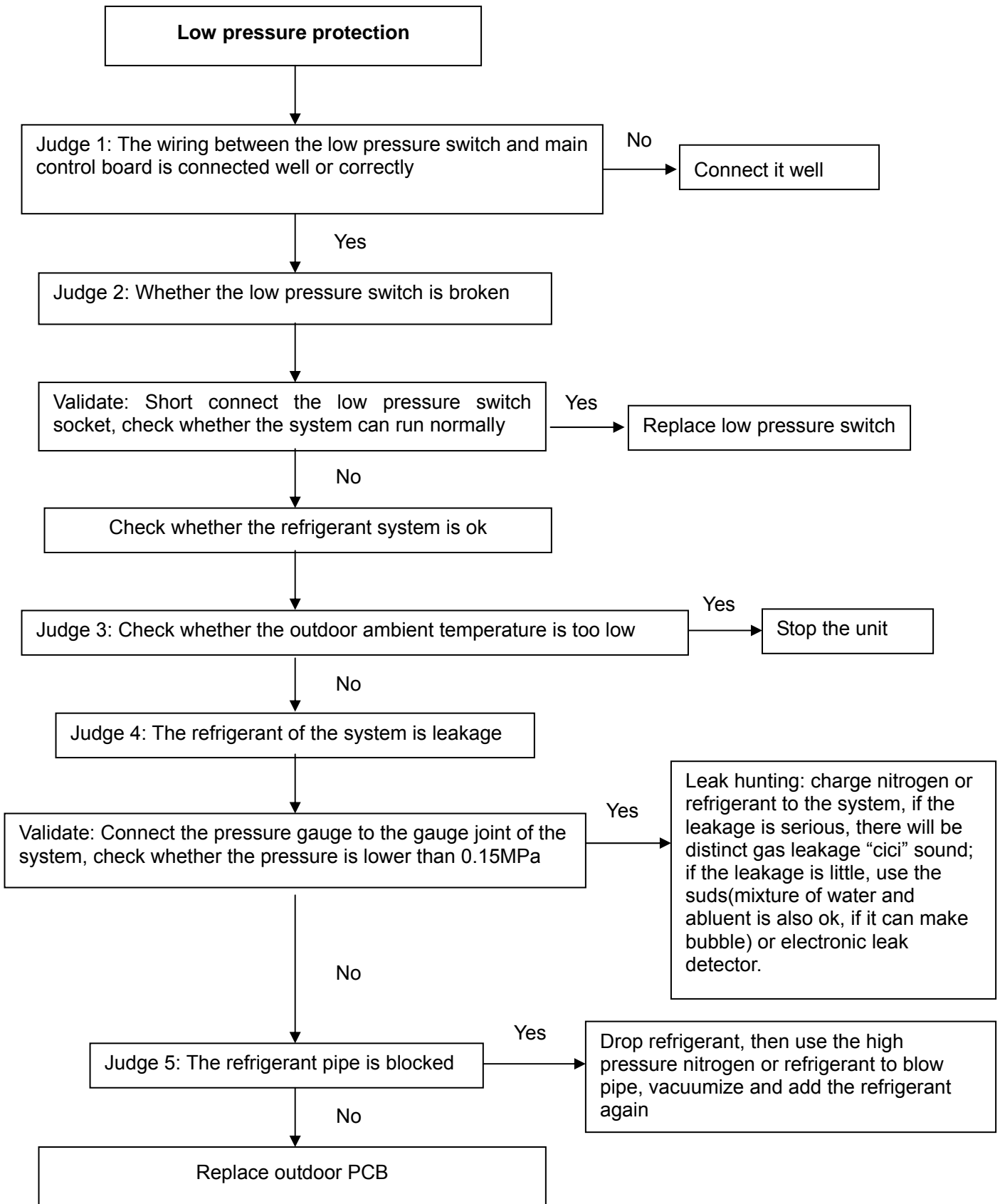

Part 4 Installation

1. Note	60
2. Installation of Indoor Units	61
3. Installation of Outdoor Units	66
4. Heat Insulation of the Pipe	75
5. Installation of Connective Pipe	76
6. Installation of Drain Pipe	82
7. Electric Connection	83
8. Methods of configuring and selecting installation	89

1. Note

CAUTION:

- Install the unit where enough space of installation and maintenance is available.
- Install the unit where the ceiling is horizontal and enough for bearing the weight of the indoor unit.
- Install the unit where the air inlet and outlet are not baffled and are the least affected by external air.
- Install the unit where the supply air flow can be sent to all parts in the room.
- Install the unit where it is easy to lead out the connective pipe and the drain pipe.
- Install the unit where no heat is emitted from a heat source directly.
- Installing the equipment in any of the following places may lead to faults of the equipment (if that is inevitable, consult the supplier):
 - The site contains mineral oils such as cutting lubricant.
 - Seaside where the air contains much salt.
 - Hot ring area where corrosive gases exist, e.g., sulfide gas.
 - Factories where the supply voltage fluctuates seriously.
 - Inside a car or cabin.
 - Place like kitchen where oil permeates.
 - Place where strong electromagnetic waves exist.
 - Place where flammable gases or materials exist.
 - Place where acid or alkali gases evaporate.
 - Other special environments.
- Install the unit where enough space of installation and maintenance is available.
- Install the unit where the air inlet and air outlet are free from obstacles and strong wind.
- Install the unit in a dry and well ventilated place.
- Install the unit where the bearing surface is level and can bear weight of the unit, and is suitable for installing the unit horizontally without increasing noise or vibration.
- Install the unit where the operation noise and the expelling of air do not affect neighbors.
- Install the unit where no flammable gas is leaked.
- Install the unit where it is convenient for pipe connection and electric connection.

2. Installation of Indoor Units

2.1 Installation of Duct

2.1.1 Installation Space

Ensure enough space required for installation and maintenance. (Fig-1 and Fig-2)

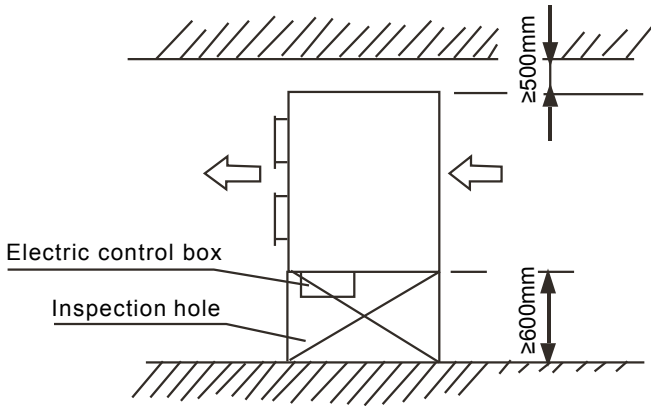

Fig-1

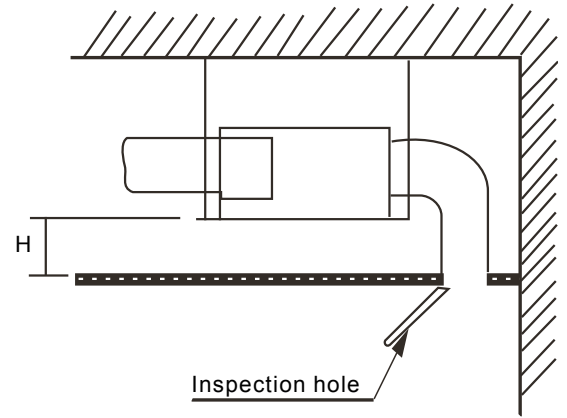
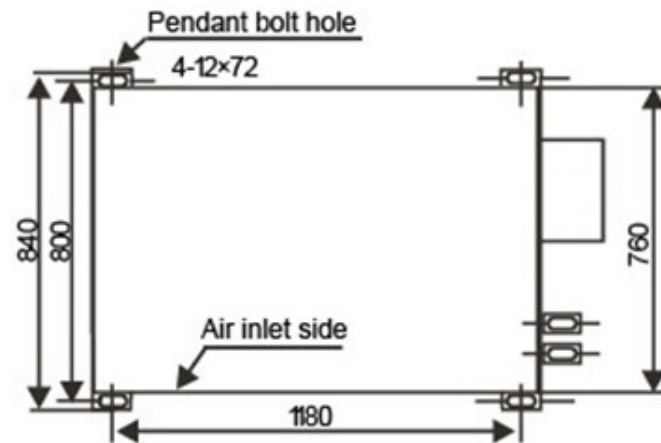
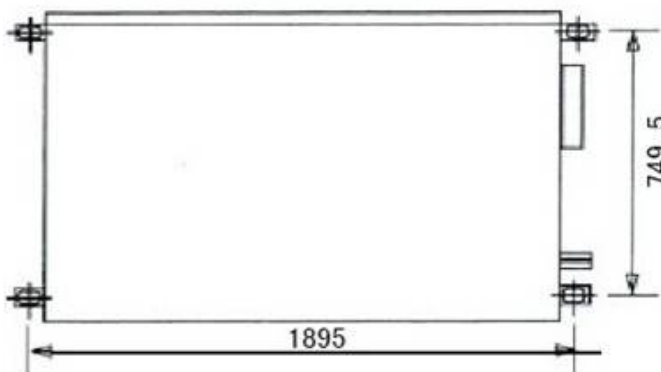

Fig-2

2.1.2 Install $\Phi 10$ Pendant Bolts Or Ground Bolts (Fig-3)



MTA-76C(H)RN1
 MTA-96C(H)RN1
 MHB-76C(H)RN1
 MHB-96C(H)RN1



MTA-120C(H)RN1
 MTA-150C(H)RN1

Fig-3

1. Use f10 or bigger screws. The screw material is high-quality carbon steel (whose surface is zinc plated or undergoes other rustproof treatment) or stainless steel.
2. The treatment of the ceiling varies between buildings. For detailed measures, consult with the fitting-out staff.

3. Fix the pendant bolts firmly and reliably in light of the specific situation.

4. Installation of the pendant bolt in different environments.

A. Wooden structure

Put rectangular sticks across the beams, and set pendant bolts. (Fig-4)

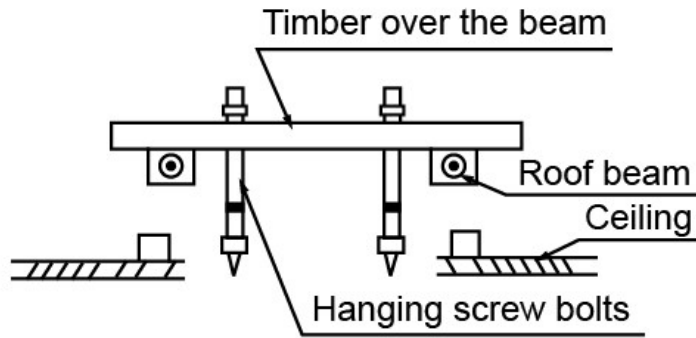

Fig-4

B. New concrete roughcast

Use embedded bolts, embedded pulling plugs, and embedded stick harness. (Fig-5)

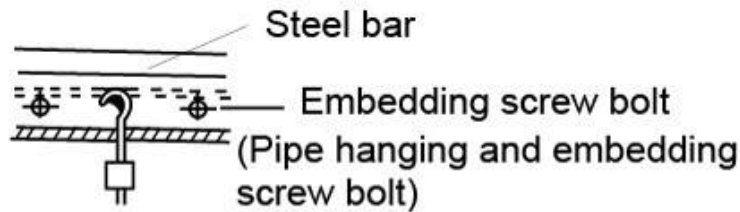

Fig-5

C. New concrete roughcast

Set it with embedded bushes or embedded bolts. (Fig-6)



Fig-6

D. Steel beam and girder structure

Set and use supportive angle steel. (Fig-7)

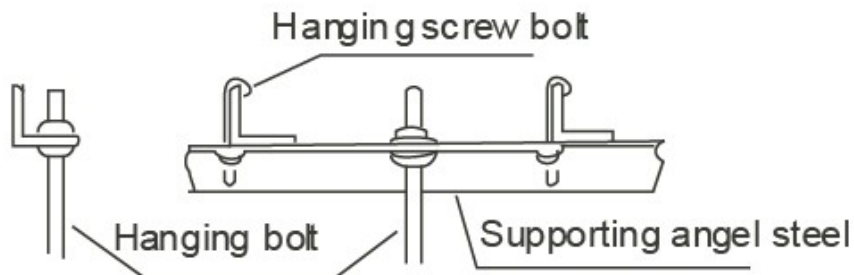

Fig-7

2.1.3 Suspending the Indoor Unit

Use a hoisting device to hoist the indoor unit, align it with the installation screw, adjust the horizontality and then tighten it. (Fig-8)

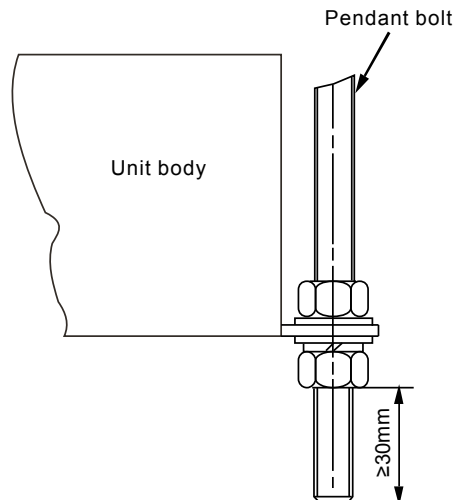

Fig-8

2.1.4 Design and Connection of Duct

- The duct design must comply with the national heating air conditioner pipeline design specifications.
- The duct accessories and materials must be produced by professional manufacturers.
- In order to prevent air flow shorting, do not keep the air inlet pipe near the air outlet pipe.
- Install a filter at an easy-to-maintain place such as intake pipe. (Otherwise, the duct will gather on the air heat exchanger and lead to fault and water leak of the air conditioner.)
- In order to suppress noise effectively, install noise suppression and sound insulation devices, especially in the noise-sensitive spaces such as meeting rooms.
- For connection of the flange plane, use non-flammable canvas adapter to prevent transmission of vibration. For its size, see the indoor unit outline diagram. Use M6X20 screws (configured on site) for connection.
- All pipelines must be connected closely and soundly without leak of air. The pipelines must be adiabatic and free from condensation.

Key points of duct connection (Fig-9)

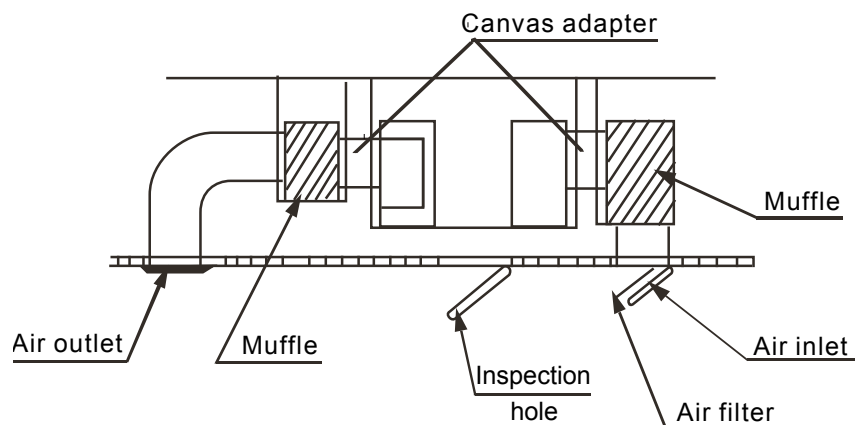

Fig-9

2.2 Installation of Floor-standing

2.2.1 Installation Space

For ensure the proper installation

Select the enough solid and level sites.

Ensure enough space required for installation and maintenance. (Fig-10and Fig-11)

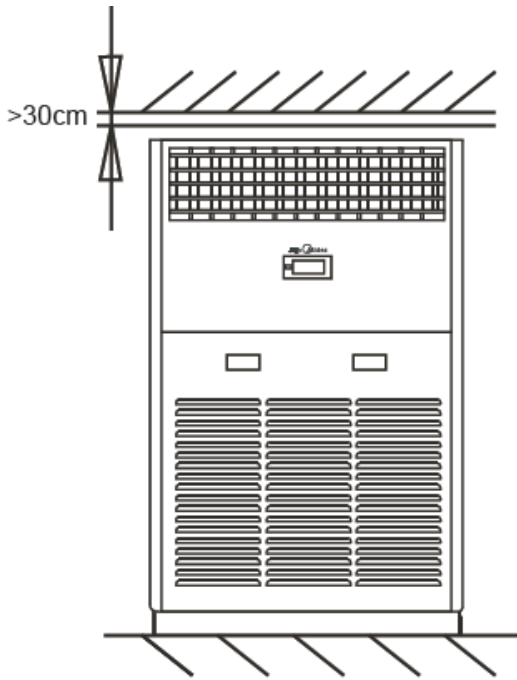

Fig-10

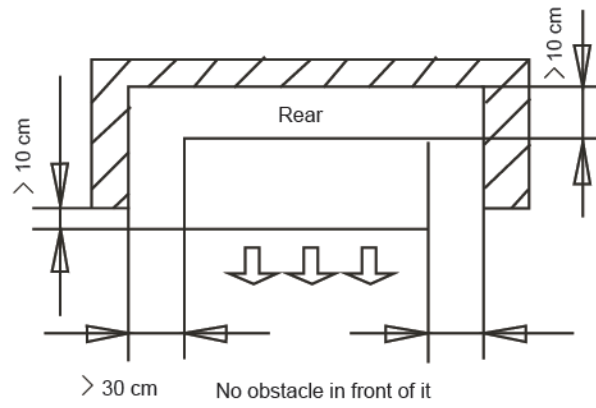
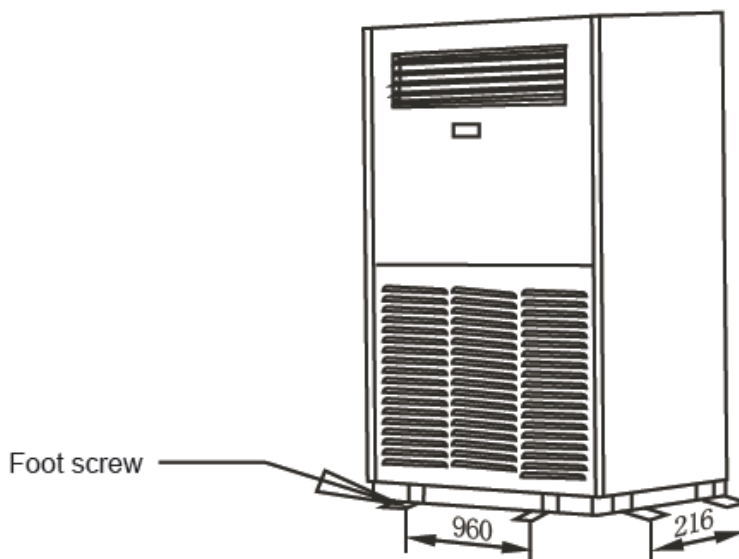

Fig-11

For anti-fall down, please conduct the follow measures:

- See Fig-12 to fix the feet on the floor after select a proper place for installation, since the height of this unit casing is very high.
- The right and left sides as well as rear can be fixed, please select the unit fixed measure as per to your actual installing ambient.



(Unit:mm)

Fig-12

Put down the air intake panel, before electric connection:

- Uncover the screw-cap in the air intake panel, and then lessen the screws.
- Take off the air intake panel; ensure which place secure enough will not make risk to the other people.

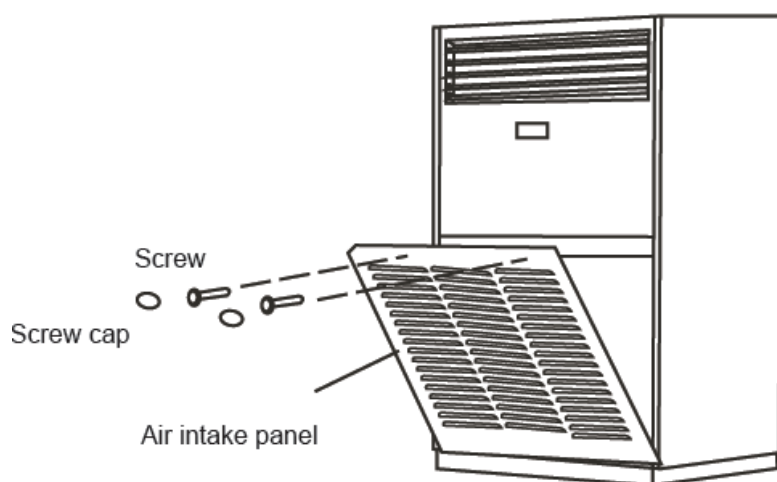

Fig-13

NOTE:

Please beware of the foot screw, which may be hurt for the pass-by people, make sure enough security of that, prevent accident occurs.

3. Installation of Outdoor Units

3.1 Important: Construction Checkpoints

1). Installation

Check the model and name to avoid mistaken installation.

2). Refrigerant pipe

- The refrigerant pipes must have the specified diameter.
- Nitrogen of a certain pressure must be filled into the refrigerant pipe before welding.
- The refrigerant pipe must undergo heat insulation treatment.
- After the refrigerant pipe is installed completely, the indoor unit cannot be powered on before performing the airtight test and creating a vacuum.

3). Pressure test

The refrigerant pipe must undergo the airtight test [with 2.94MPa (30kgf/cm²G) nitrogen].

4). Creating a vacuum

Be sure to use the vacuum pump to create a vacuum of the connective pipe at both air side and liquid side concurrently.

5). Refrigerant replenishment

- If the pipe is longer than the reference pipe, the refrigerant replenishment quantity for each outdoor unit should be calculated through the formula obtained according to the actual length of the pipe.
- Record the refrigerant replenishment quantity, actual length of pipe and the height difference of the indoor & outdoor units onto the operation confirmation table (on the electric control box) of the outdoor unit in advance for future reference.

6). Electric wiring

- Select the power supply capacity and wire size according to the design manual. The power wire size of the air conditioner should be greater than that of ordinary motors.
- In order to prevent disoperation of the air conditioner, do not interleave or entwine the power cable (380~415V/3N/50Hz) with the connection wires (low-voltage wires) of the indoor/outdoor unit.
- Power on the indoor unit after performing the airtight test and making a vacuum.

7). Trial run

Perform the trial run only after the outdoor unit has been powered on for over 12 hours.

3.2 Installation Space

- When installing the unit, leave a space for maintenance shown in the following figure. Install the power supply at the side of the outdoor unit.
- Ensure enough space for installation and maintenance. (Fig-14 and Fig-15)

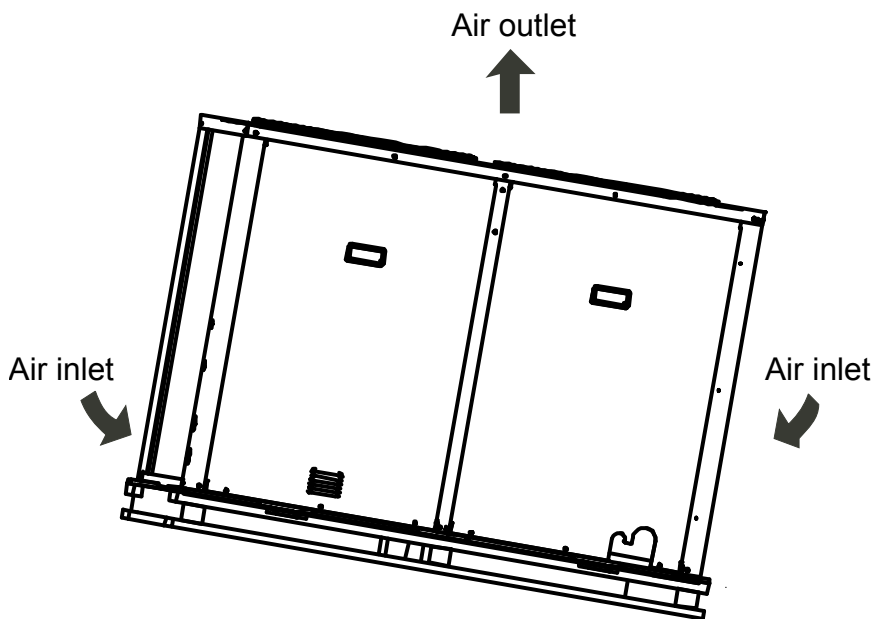

Fig-14

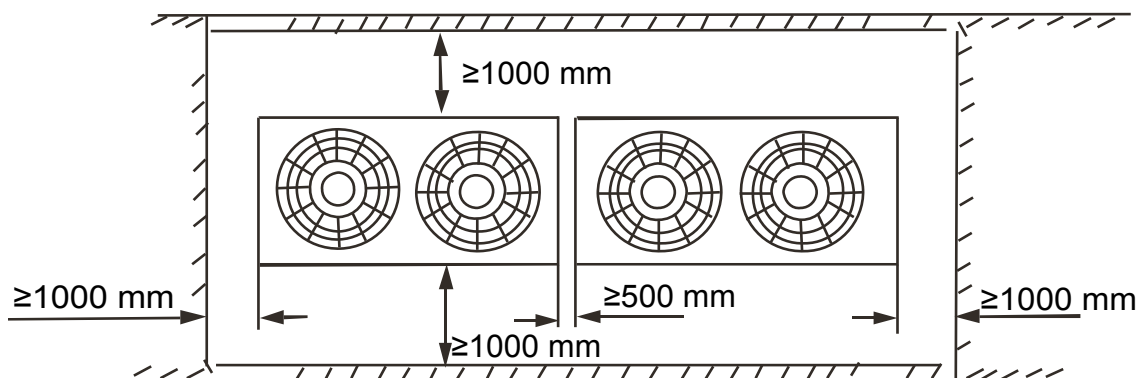

Fig-15

NOTE:

1. In case any obstacles exist above the outdoor unit, such obstacles must be 2000mm above the outdoor unit.
2. If miscellaneous articles are piled around the outdoor unit, such articles must be 400mm below the top of the outdoor unit.

As shown in Fig-16, leave an interval of 500mm between the outdoor units.

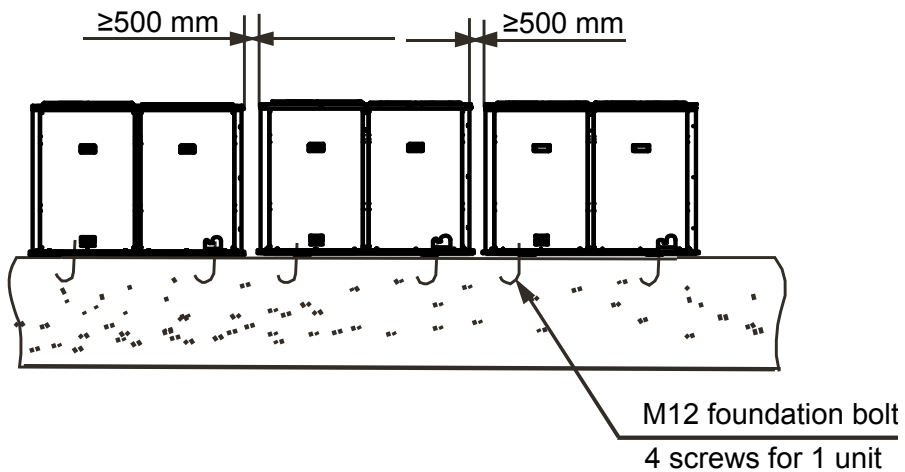

Fig-16

The distance of the foundation bolt is shown in Fig-17.

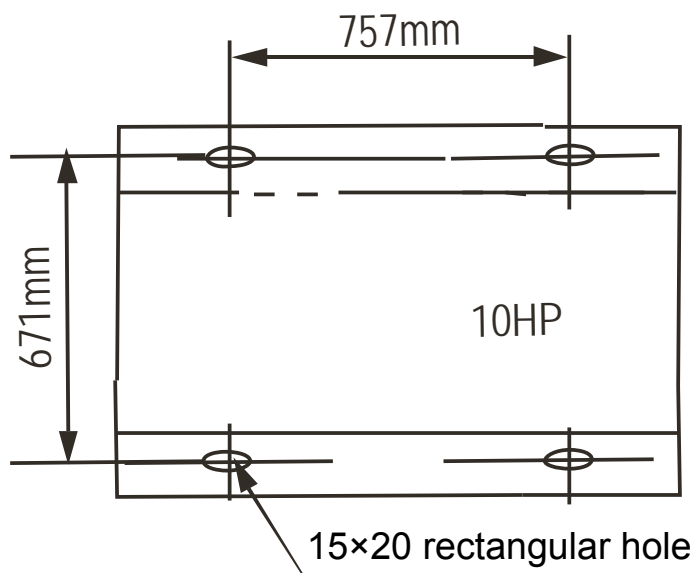

Fig-17

3.3 Convey Outdoor Unit

- Use 4 steel ropes of a $\Phi 6\text{mm}$ or bigger size to hoist the outdoor unit and convey it into the room.
- In order to prevent scratch and deformity the outdoor unit, apply a guard board to the surface of contact between the steel ropes and the air conditioner.
- Remove the cushion for use in the transport after finishing the transport. (Fig-18)
- Fork truck can be used for conveying.

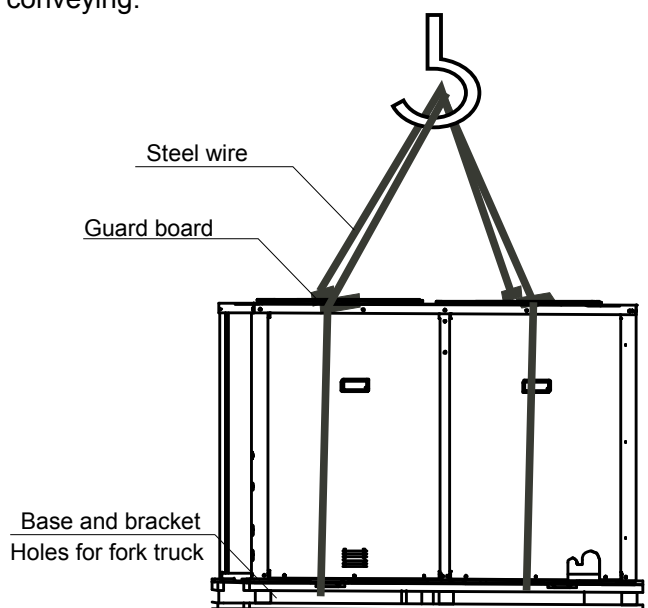

Fig-18

3.4 Snow protection facilities must be installed in the snowfall areas. (Fig-19)

In case the snow protection facilities are incomplete, faults may occur. In order to prevent influence caused by snow, set up raised pavilion, and install snow protection sheds at the air inlet and air outlet.

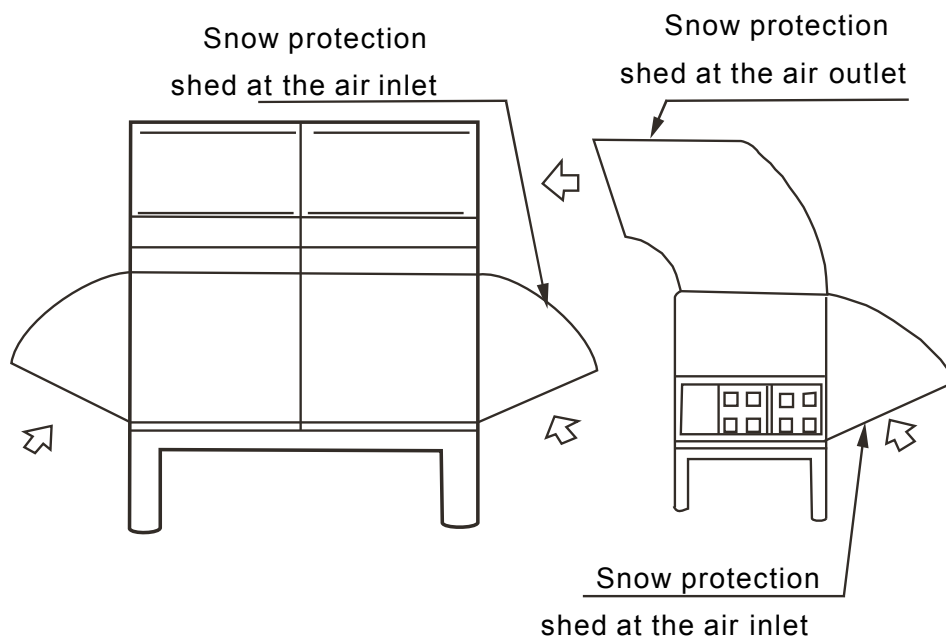

Fig-19

3.5 Installation of Refrigerant Pipe

- The refrigerant pipe adapter is located inside the outdoor unit. When the pipe is connected from the front side, the pipe can be let out through the right front board. (Fig-20 and Fig-21) So remove the left front board first. (Three M5 screws)
- The pipe can be connected from the front left lower side or the bottom notch of the outdoor unit.
- When the pipe is connected from the front side, the pipe can be led out through the pipe & wire panel.
- In case the pipe is connected from the bottom notch, install it leftward, rightward or backward after leading it out.
- When the pipe is led from the front, use a cover plate to seal the bottom notch in order to prevent intrusion of dust or trash.

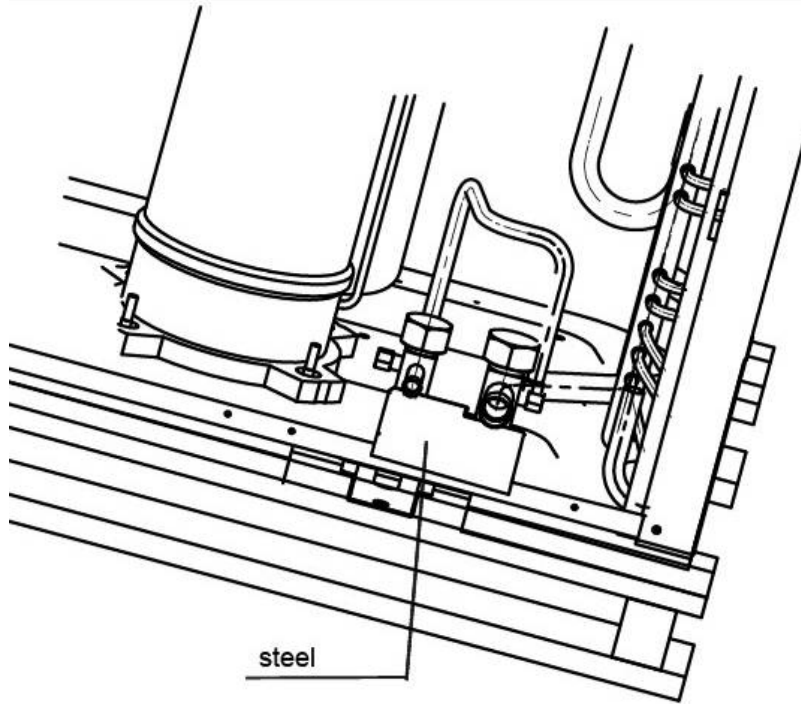

Fig-20

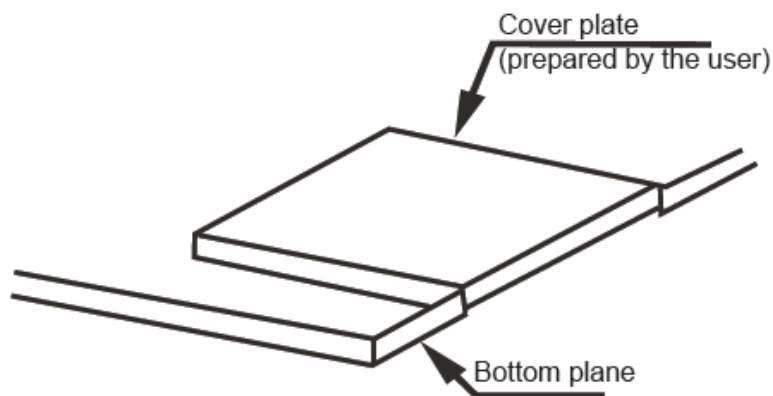

Fig-21

NOTE:

When welding the refrigerant pipe, in order to prevent internal oxidation of the pipe, nitrogen must be filled in. Otherwise, the oxidized chips may block refrigerating circulatory system.

3.5.1 Size of Outdoor Unit Pipes and Piping Methods

1) Size of outdoor unit pipes and piping methods

Model	Gas side	Liquid side
MOV-76CN1-C	Φ22	Φ9.52
MOV-76HN1-C	Φ22	Φ9.52
MOV-96CN1-C	Φ25	Φ9.52
MOV-96HN1-C	Φ25	Φ9.52
MOV-120CN1-C	Φ28.6	Φ12.7
MOV-120HN1-C	Φ28.6	Φ12.7

2) Allowed length of refrigerant pipe and height difference (Fig-22)

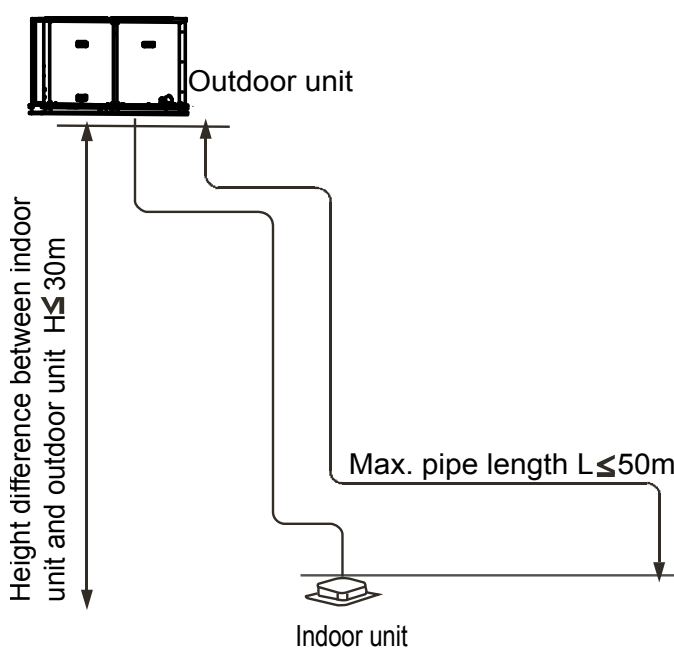
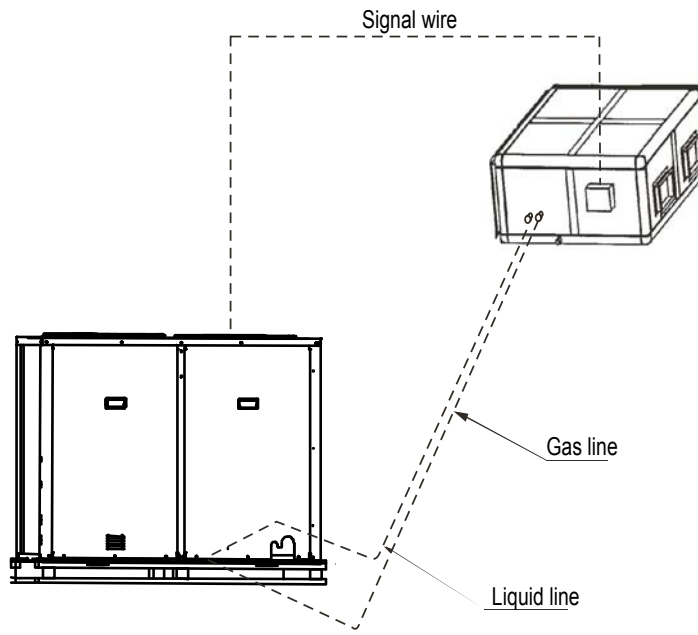

Fig-22

Table 1:

			76000 Btu/h	96000 Btu/h	50000 Btu/h	120000 Btu/h
Max. equivalent length of pipe (L)			50m	50m	50m	50m
Max. height difference	Height difference between indoor unit and outdoor unit (H)	Outdoor upper	30m	30m	30m	30m
		Outdoor lower	30m	30m	30m	30m

3) Connection between indoor unit and outdoor unit (Fig-23)



76000, 96000, 120000 Btu/h

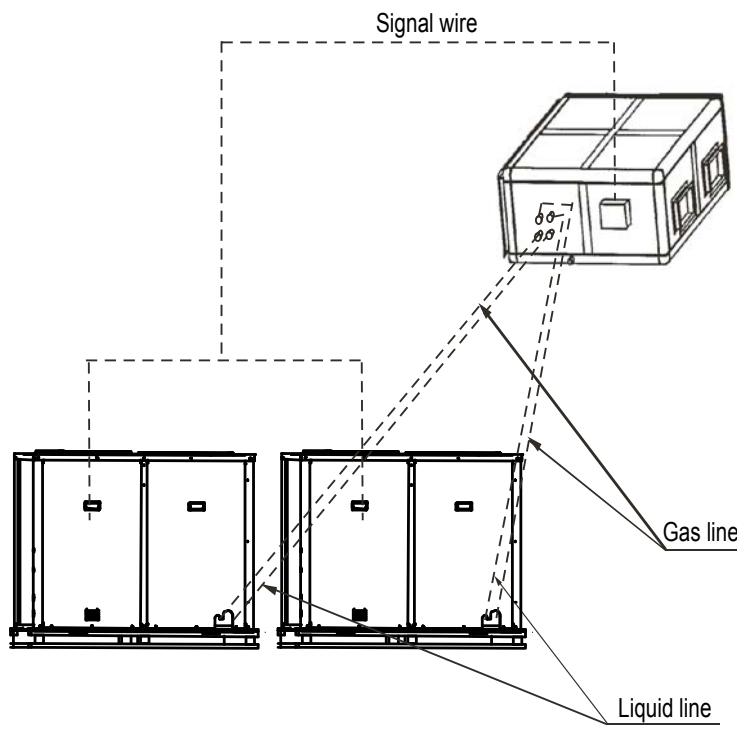

150000 Btu/h

Fig-23

3.6 Airtight Test

After the pipes between the indoor unit and the outdoor unit are connected, replenish compressed nitrogen to perform airtight test.

NOTE:

1. The airtight test is performed by using the compressed nitrogen [2.94MPa (30kg/cm²G)].
2. Tighten the spool of the gas valve and liquid valve before compressing the nitrogen.
3. Compress the nitrogen at the air vent of the gas valve.
4. The gas valve and liquid valve are closed in the process of compressing the nitrogen.
5. Do not use oxygen, flammable gas or toxic gas in the airtight test.

3.7 Vacuumize

Use a vacuum pump to make a vacuum. Do not use refrigerant gas to expel air. When making the vacuum, start from the air side.

3.8 Open All Valves

3.9 Additional Charge of Refrigerant

According to the diameter and length of the connective liquid side pipe of the outdoor unit and indoor unit, calculate the refrigerant replenishment quantity. The refrigerant for replenishment is R410A.

Table 2:

Diameter of liquid line	Quantity of refrigerant replenished for 1m pipe length
φ 9.52	0.060kg
φ 12.7	0.115kg

3.10 Remove Trash and Moist in the Pipe

- Trash and foreign matters may come into the pipe in the process of installing the refrigerant pipe. Be sure to blow them off with nitrogen before connecting the pipe to the outdoor units.
- Use high-pressure nitrogen to clean the pipelines. Do not use the refrigerant of the outdoor unit for cleaning.

3.11 Refrigerant Leak Precautions

This air conditioner uses refrigerant R410A. The R410A is safe refrigerant which is harmless and non-flammable. The room for placing the air conditioner should have a proper space. Even if refrigerant leakage occurs, the density threshold will not be crossed. Additional measures may also be taken.

1) Density threshold: Density of the Freon gas that does not harm the human body. Density threshold of R410A: 0.3 [kg/m³]

- Calculate the total quantity of refrigerant to be replenished (A [kg]). Total refrigerant quantity for 10HP = refrigerant replenishment quantity upon shipment (11[kg]) + additional refrigerant replenishment corresponding to the pipe length
- Calculate out the indoor volume (B [m³]) (according to the minimum volume)
- Calculate out the refrigerant density:

$$\frac{A[\text{kg}]}{B[\text{m}^3]} \leq \text{Density threshold: } 0.3 [\text{kg}/\text{m}^3]$$

2) Measures against crossing of the refrigerant density threshold

- In order to keep the refrigerant density below the threshold value, please install a mechanic ventilation device. (Perform ventilation often)
- In case frequent ventilation is impossible, please install the leakage detection alarm device linked with the mechanical ventilation device.

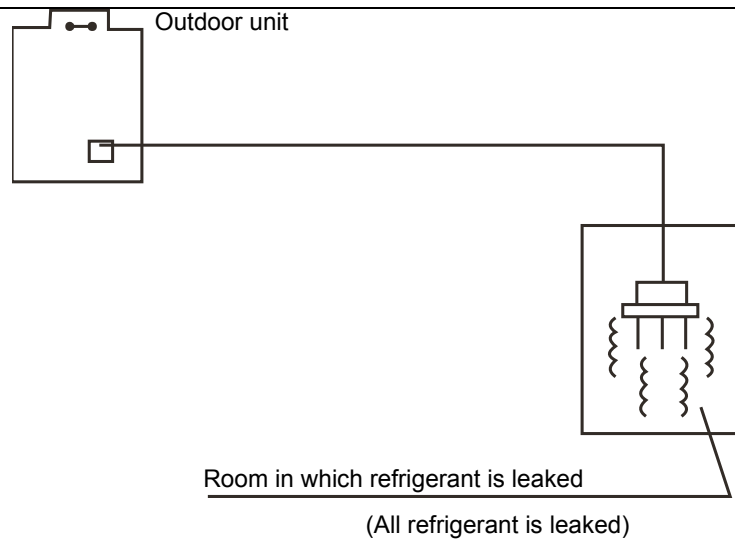

Fig-24

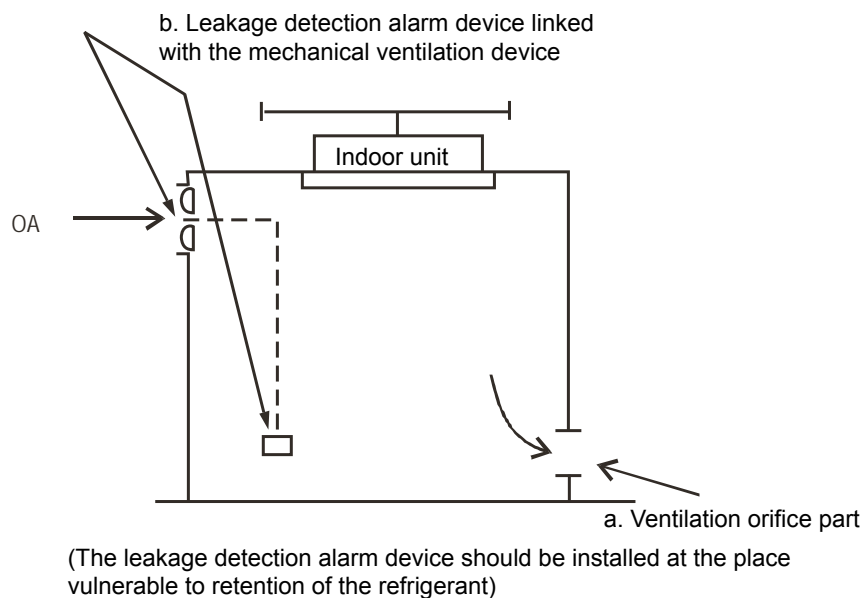

Fig-25

3.12 Completing the Connection System Name

In case multiple systems are set, in order to identify the connection system of the indoor unit and outdoor unit, it is necessary to give name to each system, and mark it onto the nameplate on the electric control box cover of the outdoor unit.

NOTE:

- The indoor unit and outdoor unit are categorized into system A and system B. When installing and connecting the indoor unit and outdoor unit, identify the label carefully, and make sure that indoor unit corresponds to the outdoor unit exactly. Otherwise, it may lead to fault of the air conditioner.
- Model of indoor unit. Room name
Example: the first system indoor unit A of the 2nd floor is recorded as: 2F 1A.

4. Heat Insulation of the Pipe

4.1 Heat Insulation of the Pipe

In order to prevent faults caused by condensate of the refrigerant pipe and drain pipe, perform condensate prevention and heat insulation properly.

CAUTION:

If it is forecast that high humidity/temperature environment (condensate temperature is over 23°C) may exist in the ceiling, e.g., inside the ceiling with slab, ceiling which is in the same environment as the outdoor air), it is necessary to apply 10mm or thicker adiabatic wool (16~20kg/m²) to the refrigerant pipe and the drain pipe in addition to applying the general heat insulation materials. Enough heat insulation materials should also be applied to the refrigerant joint and the pipe joint.

4.2 Heat Insulation of the Drain Pipe

- Be sure to entwine heat insulation materials round the drain pipe which runs through the room.
- Carry through heat insulation for the drain pipes thoroughly.

4.3 Heat Insulation of the Refrigerant Pipe

- Please use heat-resistant materials as heat insulation materials of the air-side pipe. (e.g., EPT)
- Cover heat insulation materials separately at the liquid side and the air side. Moreover, perform heat insulation thoroughly for the air-side pipes of the indoor unit, and prevent water from dripping outside the unit.

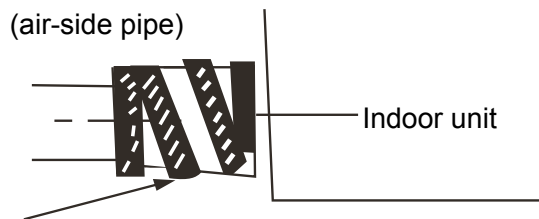

- After applying the auxiliary heat insulation materials, use vinyl resin tape to seal it lest water leak.

5. Installation of Connective Pipe

5.1 Preparation before Installation

Check the height difference between the indoor unit and the outdoor unit, and check the length and number of bends of the refrigerant pipeline, which must meet the following requirements:

- Max. Height difference....30m (If the height difference is greater than 5m, it is better to put the outdoor unit above the indoor unit).
- Max. Pipeline length.....50m.
- Max. Number of bends....15.
- In the process of installing the connective pipe, do not let the air, dust or foreign substance intrude into the pipeline system.
- Install the connective pipe only after fixing the indoor and outdoor units.
- Keep dry when installing the connective pipe. Do not let moist intrude into the pipeline system.

5.2 Procedure of Connecting Pipes

5.2.1 Measure the required length of the connective pipe, and make the connective pipes in the following procedure.

5.2.1.1 Connect the indoor unit first, and then connect the outdoor unit.

The pipe bend should be handled carefully, without damaging the pipe.

NOTE:

1. Before screwing up the flared nut, apply refrigerant oil at the outer surface of the pipeline flare and the taper surface of the connection nut. Screw up the nut for 3~4 circles beforehand.
2. When connecting or disconnecting the pipeline, be sure to use two spanners concurrently.
3. Do not rest the weight of the connective pipe on the adapter of the indoor unit. Too heavy load on the adapter of the indoor unit may deform the pipe and thus affect the cooling/heating effect.

5.2.1.2 The valve of the outdoor unit should be closed completely (as in the factory status). Every time when connecting the pipe, screw off the nut at the valve, and connect the flared pipe (within 5 minutes). If the nut is put away for a long time after being screwed off the valve, dust and other foreign substance may intrude into the pipeline system and lead to fault. Before connecting the pipe, use the refrigerant to expel air out of the pipe.

5.2.1.3 After the refrigerant pipe is connected to the indoor and outdoor units, expel air as instructed in the "Expel air" section. After expelling the air, screw up the nut at the maintenance orifice.

5.2.1.4. Precautions for the flexible part of the pipeline

The bend angle shall not exceed 90°.

The bend shall be preferably in the middle of the pipe length, and higher bend radiuses are preferred. Do not bend the flexible pipe for over 3 times.

5.2.1.5 Bend the thin-wall connective pipe

When bending the pipe, cut out a notch of the desired size at the bend of the adiabatic pipe, and then expose the pipe (wrap the pipe with the wrapping tape after bending it).

The radio of the elbow pipe should be as large as possible to prevent flattening or crush.

Use the pipe bender to make close elbow pipe.

5.2.1.6 Use purchased copper pipe

When the copper pipe is purchased from the market, be sure to use the heat insulation materials of the same type (with a thickness of over 9mm).

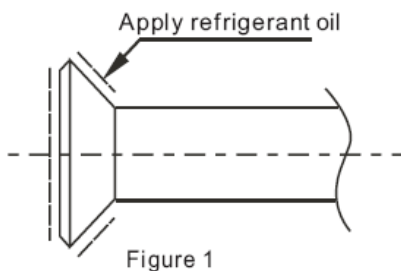

Figure 1

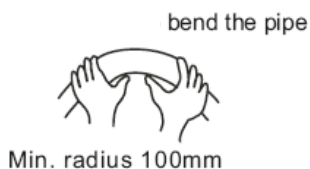

Figure 2

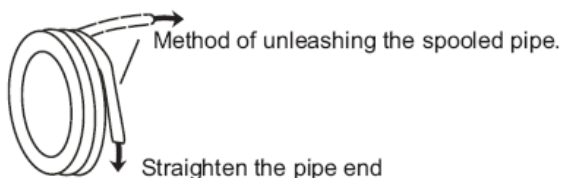

Fig-27

5.2.2 Deploy the pipelines

- Drill a porthole on the wall, and put the hole sheath and hole cover through the wall.
- Place the connective pipe together with the indoor & outdoor connection wires. Use wrapping tape to tie them tight. Do not let air penetrate into it lest condensation and drips of moist.
- Pull the connective wrapped connective pipe from outdoor through the sheath which gets through the wall, and lead it into the room. Lay out the pipelines carefully lest damage to the pipes.

5.2.3. Make a vacuum of connective pipeline.

5.2.4. After the above steps are completed, the spool of the valve of the outdoor unit should be completely open, and the refrigerant pipeline of the indoor unit and the outdoor unit should be smooth.

5.2.5. Use leak detector or soap water detect leak carefully to prevent leakage.

5.2.6. Put on an adiabatic envelope (accessory) at connective pipe adapter of the indoor unit, and wrap it tight with the wrapping tape lest condensate and leakage.

• Flare

- Use a pipe cutter to cut off the pipe.

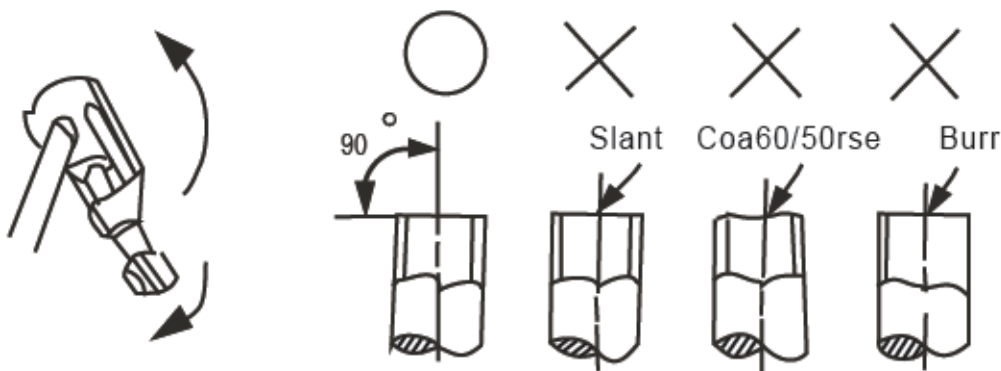

Fig-28

b. Pull the pipe into the rear flare of the connective nut.

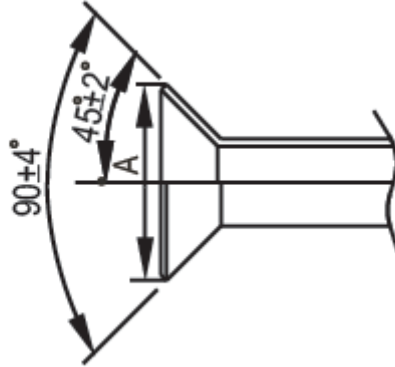

Fig-29

• **Tighten the nut**

Align with the connective pipe

Screw up the connection pipe nut manually, and use a spanner to tighten it as shown in Fig-38

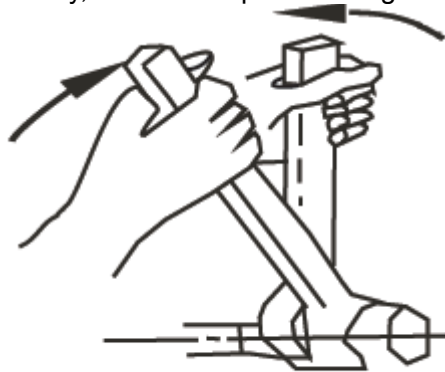

Fig-30

NOTE:

According to the installation conditions, too large torque will damage the flaring, and too small torque will lead to looseness and leakage. Determine the tightening torque by reference to the following table.

• **Replenishment quantity of refrigerant required for air conditioner**

The single-pass pipe is shorter than 5 m, and no additional length is required (note: The unit has been replenished before being shipped).

If the single-pass pipe length is 5 m or more, the quantity of fluorine required to be replenished is 0.060X (L-5). (Unit: kg)

Record the replenishment quantity of the refrigerant and keep the record properly for reference in future maintenance.

Table 3:

Pipe diameter	Torque
φ 6.35	1420~1720N.cm (144~176kgf.cm)
φ 9.53	3270~3990N.cm (333~407kgf.cm)
φ 12.7	4950~6030N.cm (504~616kgf.cm)
φ 16.0	6180~7540N.cm (630~770kgf.cm)
φ 19.0	9720~11860N.cm (990~1210kgf.cm)

5.3 Expelling Air

5.3.1. From the following table, select a method of expelling air.

Table 4:

Length of connective pipe (single pass)	Procedure of expelling air
Less than 5m	Use refrigerant in the outdoor unit
5~15m	Use vacuum pump or refrigerant tank.

If the air conditioner is relocated, be sure to use a vacuum pump or refrigerant tank to expel air.

5.3.1.2. Use the refrigerant in the outdoor unit to expel air (see Fig-31 and Fig-32)

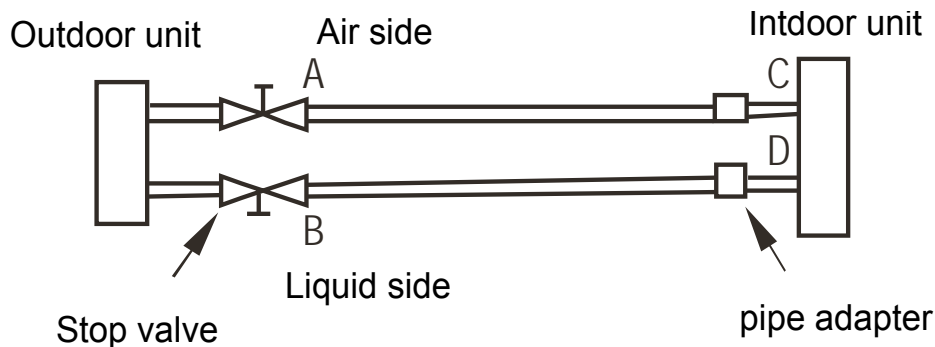

Fig-31

- Screw up the pipe nuts at A, B, C and D completely.
- Loosen and remove the square-head cover of valves A and B, rotate the square-head spool of valve B counterclockwise for 45 degrees and stay for about 10 seconds, and then close the spool of valve B tightly.
- Detect leak for all adapters at A, B, C and D. After making sure that no leak exists, open the maintenance orifice nut of valve A. After all air is expelled, tighten the maintenance orifice nut of valve A.
- Open the spools of valves A and B completely.
- Tighten the square-head cover of valves A and B completely.

5.3.1.3. Use refrigerant tank to expel air (see Fig.6-8 and Fig.6-9)

- Screw up the pipe nuts at A, B, C and D completely.
- Loosen and remove the square-head cover and the maintenance orifice nut of valves A and B.
- Connect the filler hose of the refrigerant tank with the maintenance orifice of valve A.
- Loosen the valve of the refrigerant tank, continue filling refrigerant for 6 seconds to expel the air, and tighten the nut of valve B quickly.
- Loosen the valve of the refrigerant tank again, and fill the refrigerant for 6 seconds. Detect leak for all adapters at A, B, C and D. After making sure that no leak exists, screw off the filler hose. After all the filled refrigerant is expelled, screw up the maintenance orifice nut of valve A quickly.
- Open the square-head spools of valves A and B completely.
- Tighten the square-head cover of valves A and B.

5.3.1.4. Use a vacuum pump to expel the air (Fig-32) (For method of using the manifold valve, see the operation manual of manifold valve):

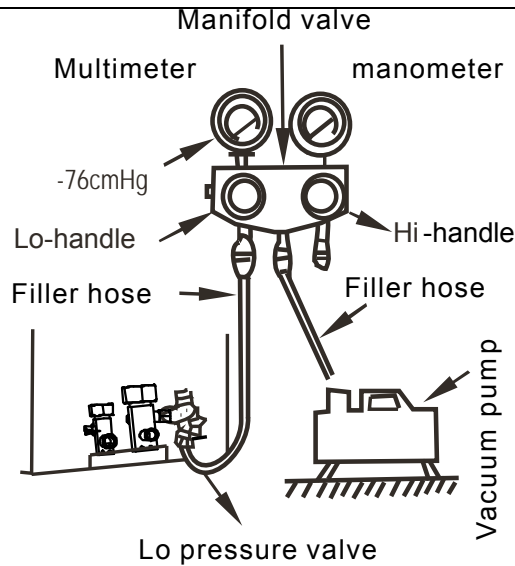

Fig-32

- Loosen and remove the maintenance orifice nut of valve A, and connect the filler hose of the manifold valve to the maintenance orifice of valve A (tighten both valve A and valve B).
- Connect the filler hose adapter to the vacuum pump.
- Open the low pressure (Lo) handle of the manifold valve completely.
- Start the vacuum pump to extract air. At the beginning of extracting air, slightly loosen the maintenance orifice nut of valve B, check whether any air enters it (the vacuum pump noise changes and the multi-meter indicate from negative to 0). Then tighten this maintenance orifice nut.
- Upon completion of vacuuming, tighten the low pressure (Lo) handle of the manifold valve completely and stop the vacuum pump. Keep extracting air for over 15 minutes. Check whether the multi-meter points at $-1.0 \times 10^5 \text{ Pa}$ (-76cmHg).
- Loosen and remove the square-head cover of valves A and B. After opening valves A and B completely, tighten the square head cover of valves A and B.
- Remove the filler hose off the maintenance orifice of valve A, and then tighten the nut.

5.3.1.5. Procedure of using stop valve

- Open the spool until it touches the stop block. Do not attempt to open further.
- Use a spanner or a similar tool to tighten the bonnet. The bonnet tightening torque is shown in Table 3 "Tightening torque".
- Upon completion of installation, open all valves before trial run. Each unit has two valves of different sizes located at the outdoor unit side. Of the two valves, one is gas valve and the other is liquid valve. The procedure of opening/closing the valve is shown in the right figure (Fig-33).
- Procedure of opening the valve: Open the square-head cover, use a spanner to capture the square head and open it thoroughly. Then tighten the square-head cover.
- Procedure of closing the valve: Same as the procedure of opening the valve, but rotate the spanner clockwise thoroughly.

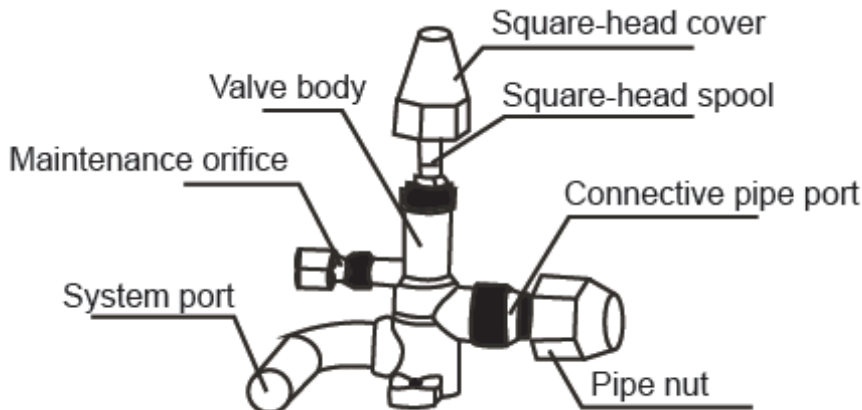

Fig-33

5.4 Leak Detection

Use soap water or a leak detector to check whether gas leakage exists at the adapters.

5.5 Heat Insulation

- Use heat insulation materials to wrap the part protruding outside the flared pipe joint and the refrigerant pipe of the liquid pipe and the gas pipe, and ensure that no gap exists between them.
- Imperfect heat insulation may lead to condensate drips.

6. Installation of Drain Pipe

6.1 Install the drain pipe of the indoor unit

- In order to prevent drain overflow, install a drainage controller at place 1 of the drain pipe. (The drainage controller is designed to smoothen the drainage when the static pressure outside the unit is high, especially at the air inlet, in addition to remove stink through the drain pipe.)
- The drain of water is natural. In the construction, the external pipe of the outdoor unit slants downward at a gradient of 1/50~1/100.
- The number of bends and folds of the drain pipe should not exceed 2. Try to avoid bends in order to prevent trash accumulation.
- In the construction, do not drop trash into the drip tray or drain pipe of the indoor unit.
- Upon completion of installing the drain pipe, remove the inspection panel. Put water into the drip tray to check whether the water can be drained levelly and steadily.

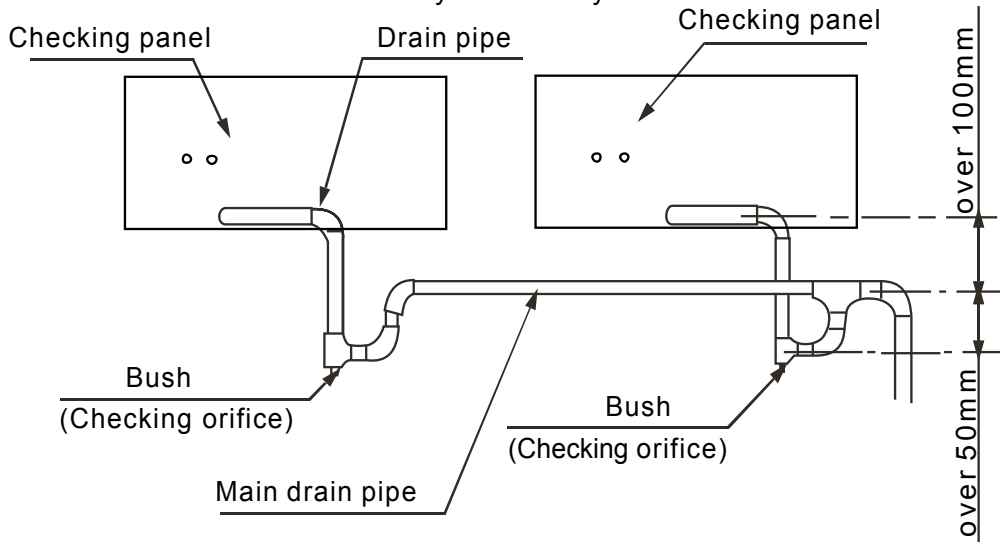

Fig-34

NOTE:

Drain pipe trash gains easily at the drainage controller. Be sure to install a stopper and a structure that cleans up trash easily.

6.2. Trial draining of the drain pipe

Open the side panels of the indoor unit, fill water inward, and check whether the water can be drained smoothly. Check water leak at the joint.

6.3. Heat insulation of drain pipe

After making sure that the water drains smoothly and no water is leaked, use adiabatic wool bushes to preserve heat of the drain pipe. Otherwise, condensate will occur.

7. Electric Connection

7.1 Electric field wiring

CAUTION:

- Use special power supply for the air conditioner. Design power supplies specific to the indoor unit and outdoor unit. The supply voltage must comply with the nominal voltage.
- The external supply circuit of the air conditioner must have a ground wire, and the power supply ground wire of the indoor unit must be connected with the external ground wire firmly.
- The wiring must be performed by professional technicians according to the circuit diagram labels.
- Distribute the wires according to the relevant electric technical standards promulgated by the State, and set the Residual Current-operated Circuit Breaker (RCCB) properly.
- The power wire and the signal wire shall be laid out neatly and properly, without mutual interference or contacting the connection pipe or valve.
- No power cable is attached to this equipment. The user can select the power cable by reference to the stipulated power supply specifications. No joint of wires is allowed.
- Upon completion of wire connection, double check it and then connect the power supply.

Duct type- 76 kBTu/h; 96 kBTu/h; 120 kBTu/h, cooling only:

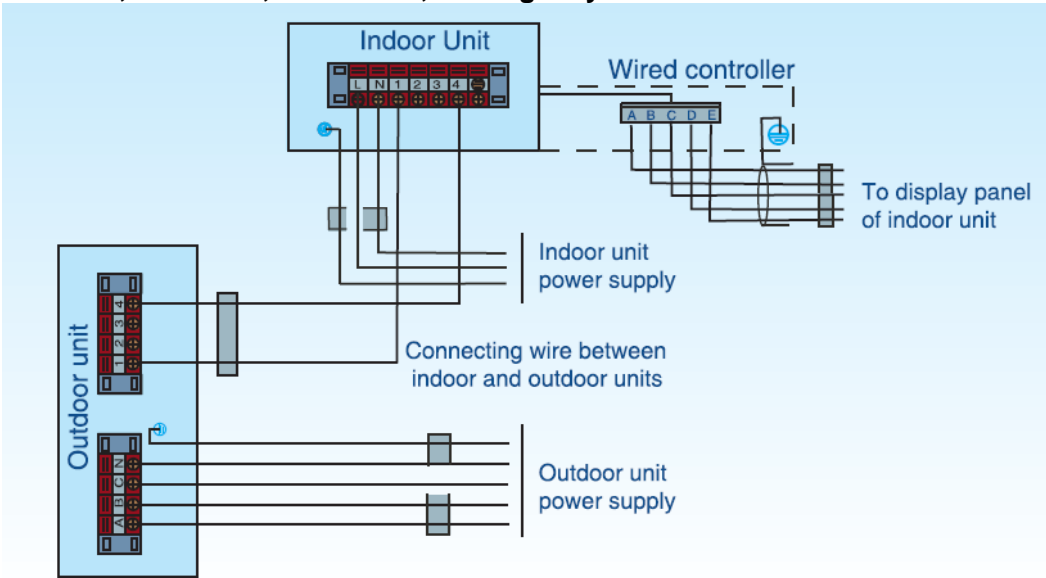

Duct type- 76 kBTu/h; 96 kBTu/h; 120 kBTu/h, cooling and heating type:

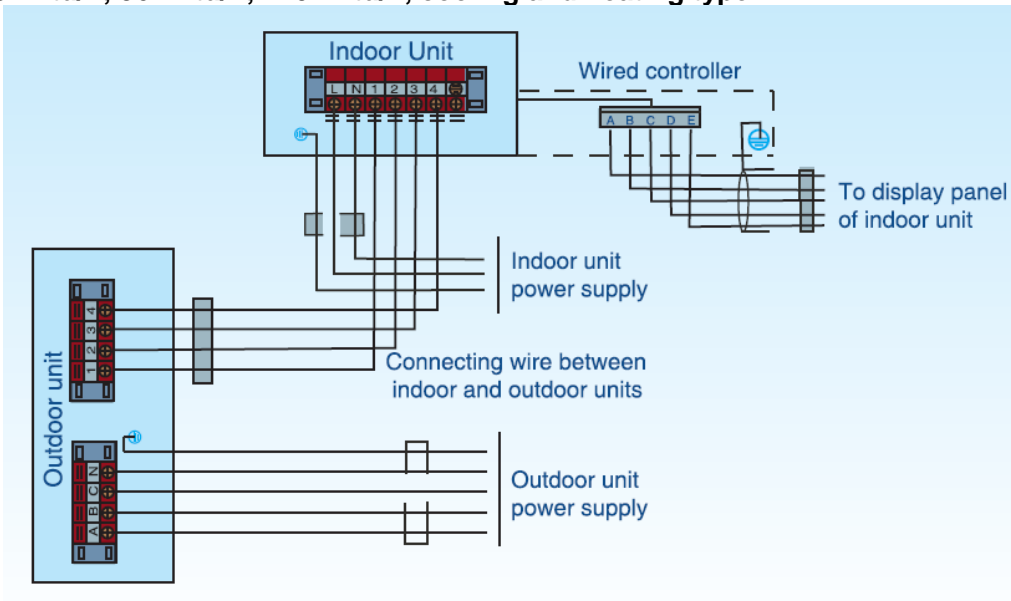

Duct type-150 kBtu/h, cooling only:

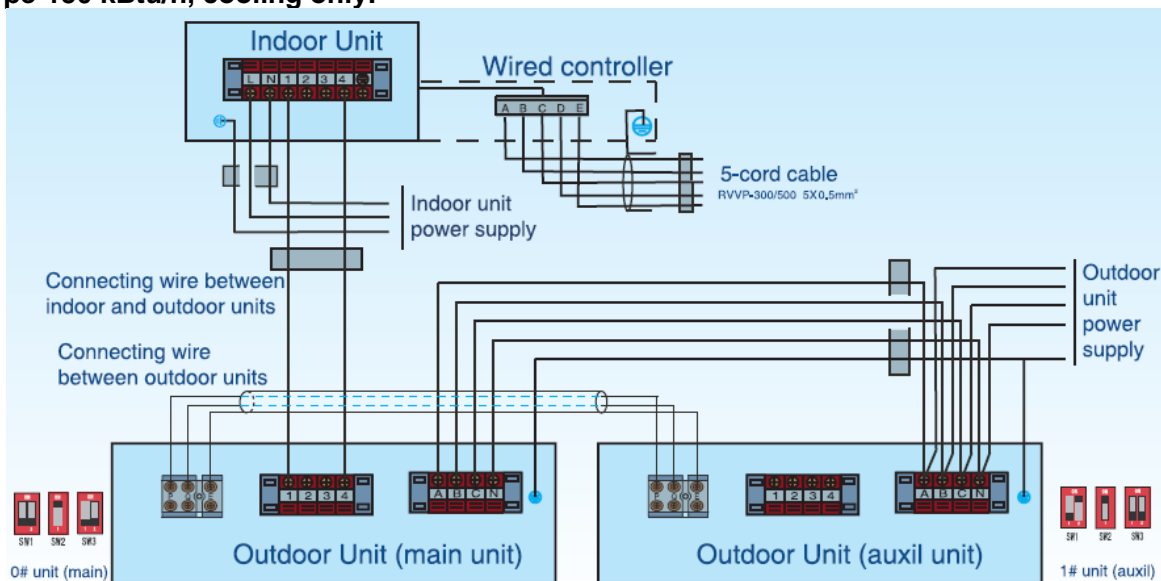

Duct type-150 kBtu/h, cooling and heating type:

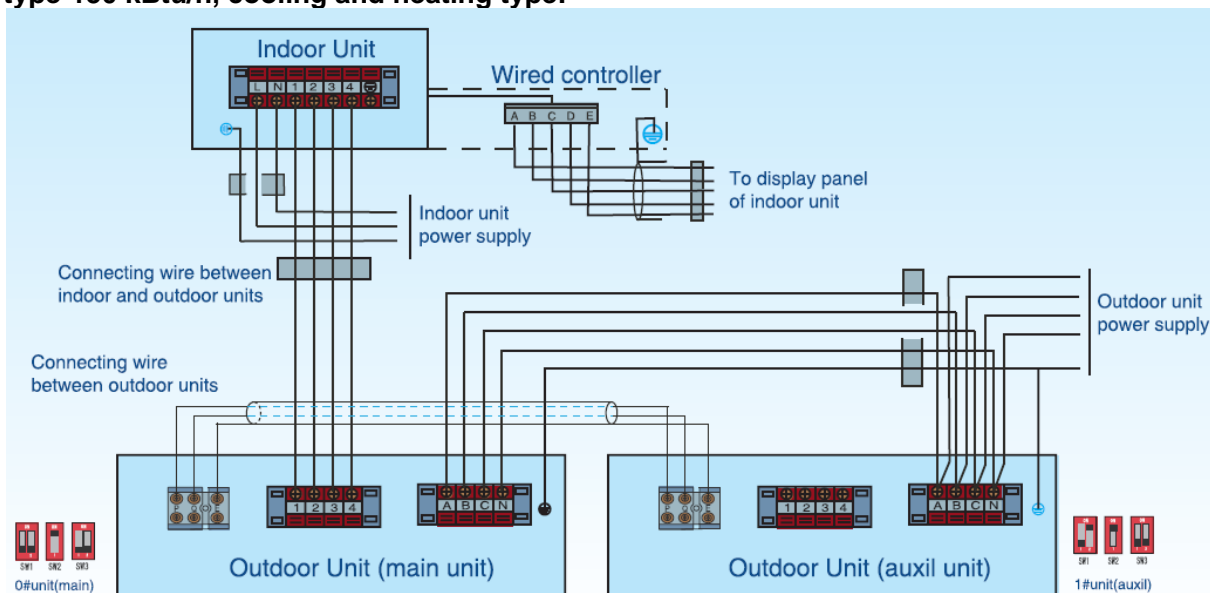

7.2 Specifications of power supply

Indoor unit:

Model	MTA-76CRN1	MTA-76HRN1	MTA-96CRN1	MTA-96HRN1
Power supply	220~240V- 1Ph-50Hz	220~240V- 1Ph-50Hz	220~240V- 1Ph-50Hz	220~240V- 1Ph-50Hz
Capacity of power supply/ fuse (A)	20/10	20/10	20/8	20/8
Indoor power cable	RVV-300/500 2*2.5mm ²	RVV-300/500 2*2.5mm ²	RVV-300/500 2*2.5mm ²	RVV-300/500 2*2.5mm ²
Grounded wire	RVV-300/500 2.5mm ²	RVV-300/500 2.5mm ²	RVV-300/500 2.5mm ²	RVV-300/500 2.5mm ²
Connective wire of indoor to outdoor unit	RVV-300/500 2*1.0mm ²	RVV-300/500 4*1.0mm ²	RVV-300/500 2*1.0mm ²	RVV-300/500 4*1.0mm ²
Wire controls connective wire	RVVP-300/300 5*0.5mm ²	RVVP-300/300 5*0.5mm ²	RVVP-300/300 5*0.5mm ²	RVVP-300/300 5*0.5mm ²

Model	MTA-120CRN1	MTA-120HRN1	MTA-150CRN1
Power supply	220~240V- 1Ph-50Hz	220~240V- 1Ph-50Hz	220~240V- 1Ph-50Hz
Capacity of power supply/ fuse (A)	40/20	40/20	20/12
Indoor power cable	RVV-300/500 2*2.5 mm ²	RVV-300/500 2*2.5 mm ²	RVV-300/500 2*2.5 mm ²
Grounded wire	RVV-300/500 2.5 mm ²	RVV-300/500 2.5 mm ²	RVV-300/500 2.5 mm ²
Connective wire of indoor to outdoor unit	RVV-300/500 2*1.0 mm ²	RVV-300/500 4*1.0 mm ²	RVV-300/500 2*1.0 mm ²
Wire controls connective wire	RVVP-300/300 5*0.5mm ²	RVVP-300/300 5*0.5mm ²	RVVP-300/300 5*0.5mm ²

Model	MHB-76CRN1	MHB-76HRN1	MHB-96CRN1	MHB-96HRN1
Power supply	220~240V- 1Ph-50Hz	220~240V- 1Ph-50Hz	220~240V- 1Ph-50Hz	220~240V- 1Ph-50Hz
Capacity of power supply/ fuse (A)	20/8	20/8	20/12	20/12
Indoor power cable	RVV-300/500 2*2.5 mm ²	RVV-300/500 2*2.5 mm ²	RVV-300/500 2*2.5 mm ²	RVV-300/500 2*2.5 mm ²
Grounded wire	RVV-300/500 2.5 mm ²	RVV-300/500 2.5 mm ²	RVV-300/500 2.5 mm ²	RVV-300/500 2.5 mm ²
Connective wire of indoor to outdoor unit	RVV-300/500 2*1.0 mm ²	RVV-300/500 4*1.0 mm ²	RVV-300/500 2*1.0 mm ²	RVV-300/500 4*1.0 mm ²
Wire controls connective wire	RVVP-300/300 5*0.5mm ²	RVVP-300/300 5*0.5mm ²	RVVP-300/300 5*0.5mm ²	RVVP-300/300 5*0.5mm ²

Outdoor unit:

Model	MOV-76CN1-C	MOV-76HN1-C	MOV-96CN1-C	MOV-96HN1-C
Power supply	380~415V- 3N-50Hz	380~415V- 3N-50Hz	380~415V- 3N-50Hz	380~415V- 3N-50Hz
Capacity of power supply/ fuse (A)	60/40	60/40	60/40	60/40
Power supply cable	YCW-450/750 4*6.0 mm ²	YCW-450/750 4*6.0 mm ²	YCW-450/750 4*6.0 mm ²	YCW-450/750 4*6.0 mm ²
Grounded wire	YCW-450/750 6.0 mm ²	YCW-450/750 6.0 mm ²	YCW-450/750 6.0 mm ²	YCW-450/750 6.0 mm ²
Connective wire of indoor to outdoor unit	RVV-300/500 2*1.0 mm ²	RVV-300/500 4*1.0 mm ²	RVV-300/500 2*1.0 mm ²	RVV-300/500 4*1.0 mm ²
Wire controls connective wire	RVVP-300/300 5*0.5mm ²	RVVP-300/300 5*0.5mm ²	RVVP-300/300 5*0.5mm ²	RVVP-300/300 5*0.5mm ²

Model	MOV-120CN1-C	MOV-120HN1-C
Power supply	380~415V- 3N-50Hz	380~415V- 3N-50Hz
Capacity of power supply/ fuse (A)	60/40	60/40
Power supply cable	YCW-450/750 4*6.0 mm ²	YCW-450/750 4*6.0 mm ²
Grounded wire	YCW-450/750 6.0 mm ²	YCW-450/750 6.0 mm ²
Connective wire of indoor to outdoor unit	RVV-300/500 2*1.0 mm ²	RVV-300/500 4*1.0 mm ²
Wire controls connective wire	RVVP-300/300 5*0.5mm ²	RVVP-300/300 5*0.5mm ²

7.3 Power wires

The power wires are as follows: (schematic diagram)

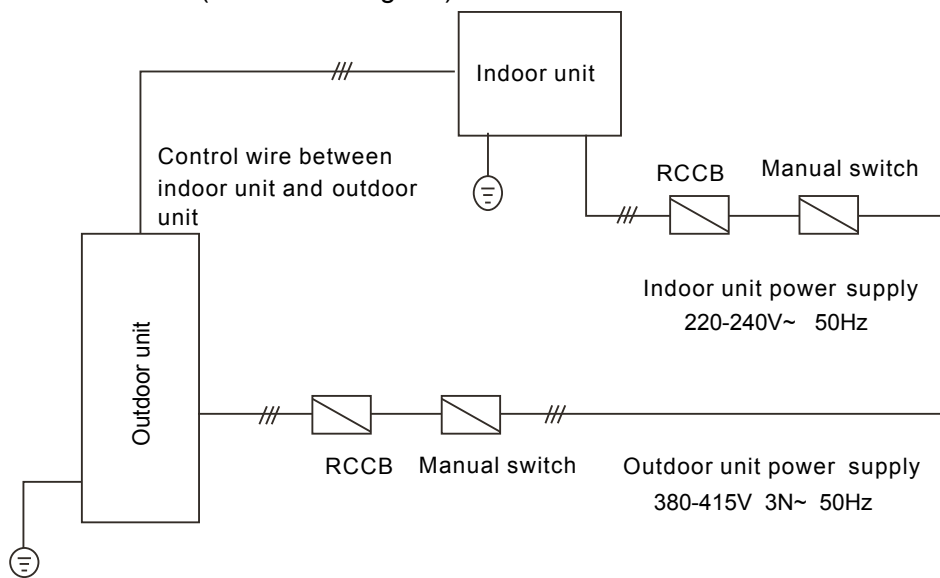
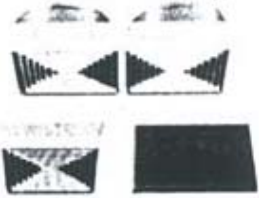



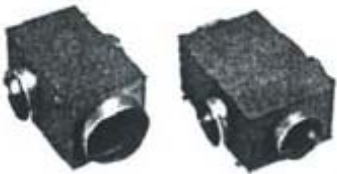



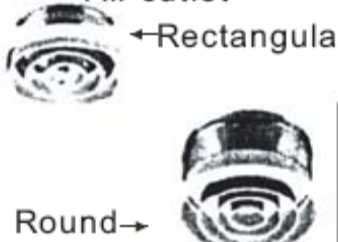





Fig-35

8. Methods of configuring and selecting installation

	Material name	Characteristics, advantages and other contents
1	<p>Air inlet wooden grille</p>  <p>Filter</p>	<ol style="list-style-type: none"> 1. Install the filter at the main body grille in case the storey height is low, and at the main body of the indoor unit in case the storey height is high. 2. It cleans conveniently at the time of installing/uninstalling the filter. 3. The button structure is easy to install and uninstall.
2	<p>Hose (for absorbing noise)</p> 	<ol style="list-style-type: none"> 1. For purpose of air inlet. 2. Must adopt fire-resistant materials. (Those materials other than specified by Midea than specified by Midea be applied) 3. The heat insulation material must be glass wool.
3	<p>Hose (for general purpose)</p> 	<ol style="list-style-type: none"> 1. For purpose of air outlet. 2. Must adopt fire-resistant materials. (Those materials other than specified by Midea than specified by Midea be applied) 3. The heat insulation material must be glass wool.
4	<p>Air inlet noise pipe</p> 	<ol style="list-style-type: none"> 1. Install the unit at the air inlet so that the air flows smoothly and the noise is lower. 2. The noise value varies with the length. 3. The hose joint should be bent lest detachment of the pipe.
5	<p>Air outlet noise pipe</p> 	<ol style="list-style-type: none"> 1. Install the unit at the air outlet so that the air flows smoothly and the noise is lower. 2. The noise value varies with the length. 3. The hose joint should be bent lest detachment of the pipe.
6	<p>Distributor</p> 	<ol style="list-style-type: none"> 1. Install the unit at the air outlet so that the air flows smoothly and the noise is lower. 2. Select 1BY2 or 1BY3 according to the quantity of the diffusers. 3. The diffuser pipes should preferably have the same length after branching, and the minimum length of the ventilation pipes is 5m.

<p>7</p>	<p>Rectangular Air outlet</p> 	<ol style="list-style-type: none"> 1. Fixed model that diffuses air at a 360 angle. 2. The outline size should increase when the air volume is over 350CMH. (For above 303), i.e., when about 9 diffusers are required, the outline size should increase. 3. The diffuser pipes should preferably have the same length after branching, and the minimum length of the ventilation pipes is 5m.
<p>8</p>	<p>Air outlet</p> 	<ol style="list-style-type: none"> 1. Fixed model that diffuses air at a 360 angle. 2. The outline size should increase when the air volume is over 350CMH. (For above 303), i.e., when about 9 diffusers are required, the outline size should increase. 3. Proper air speed: For air speed of over 2-3.5m/s, select other diffusers (with great noise). 4. Install the diffuser pipe if it is necessary to install the model of over 3.5m/s. 5. For purpose of cooling-only model.
<p>9</p>	<p>Air outlet</p> 	<ol style="list-style-type: none"> 1 The lengthwise adjustable model which diffuses air at a 360 angle. 2. With the change of the cooling/heating air flow, the horizontal and vertical distance of the fan can be adjusted (applicable to department store and exhibition hall where the decorative effect is essential).
<p>10</p>	<p>Air outlet</p>  <p>←Rectangular</p> <p>Round→</p>	<ol style="list-style-type: none"> 1. Low noise compared with other air outlets. Applicable to tall buildings that require along distance of air conditioning. 2. Select the ventilation pipe connection caliber according to the distance and the air speed. 3. Applicable to storey height of over 5m (for design of tall storey such as temple, consult Midea).
<p>11</p>	<p>Linear diffuser</p> 	<ol style="list-style-type: none"> 1. The fan is the adjustable type which can change direction of air flow. It is used for deluxe decoration. 2. The outline size should increase when the air flow is over 450CMH (3 or 4 SOLT) when about 6 diffusers are required, the outline size should increase. 3. If the proper air speed is 2.5-5m/s and actual air speed reaches over 5m/s, it is necessary to choose other diffusers (with higher noise values).

12	<p>Air outlet woodengrille</p> 	<ol style="list-style-type: none"> 1. Low noise compared with other air outlets. Applicable to tall buildings that require a long distance of air conditioning. 2. Select the ventilation pipe connection caliber according to the distance and the air speed. 3. Applicable to storey height of over 5m (for design of tall stores such as temple, consult Midea).
Auxiliary materials	<p>Duct wrapping tape</p> 	<ol style="list-style-type: none"> 1. Flanges and pipelines connected to the ventilation pipes. 2. When the noise pipe is connected with the hose, the ventilation pipe tape must be applied (otherwise, with only adhesive tape, the adhesion will be weakened due to change of temperature).
	<p>Aluminium adhesive tape</p> 	<ol style="list-style-type: none"> 1. It is used to prevent glass wool leak and seal the gas at the time of the flanges and pipelines of the ventilation pipes. 2. Entwine for over 3 circles. 3. Use ventilation pipe-specific tapes (instead of ordinary adhesive tapes). <p>In order to ensure the installation quality and durability, it is necessary to use the auxiliary materials of standard specifications provided by Midea Electronics and the auxiliary products of the specified manufactures.</p>

Part 5 Control

1. Wireless Remote Controller	93
2. Wired controller (Optional).....	99
3. Central Control Monitor (Optional)	101

1. Wireless Remote Controller: R51/CE and R51/E (Standard)

1.1 Remote Controller Specifications

Model	R51/CE and R51/E
Rated Voltage	3.0V
Lowest Voltage of CPU Emitting Signal	2.0V
Reaching Distance	8m (when using 3.0 voltage, it Gets 11m)
Environment Temperature Range	-5°C~60°C

Performance Features

1. Operating Mode: COOL HEAT DRY FAN and AUTO.
2. Timer Setting Function in 24 hours.
3. Indoor Setting Temperature Range: 17°C~30°C.
4. LCD (Liquid Crystal Display) of all functions.
5. Night Light Function (only R51/BG model available)
6. Compatible with the former R11.

1.2 Introduction of Function Buttons on the Remote Controller

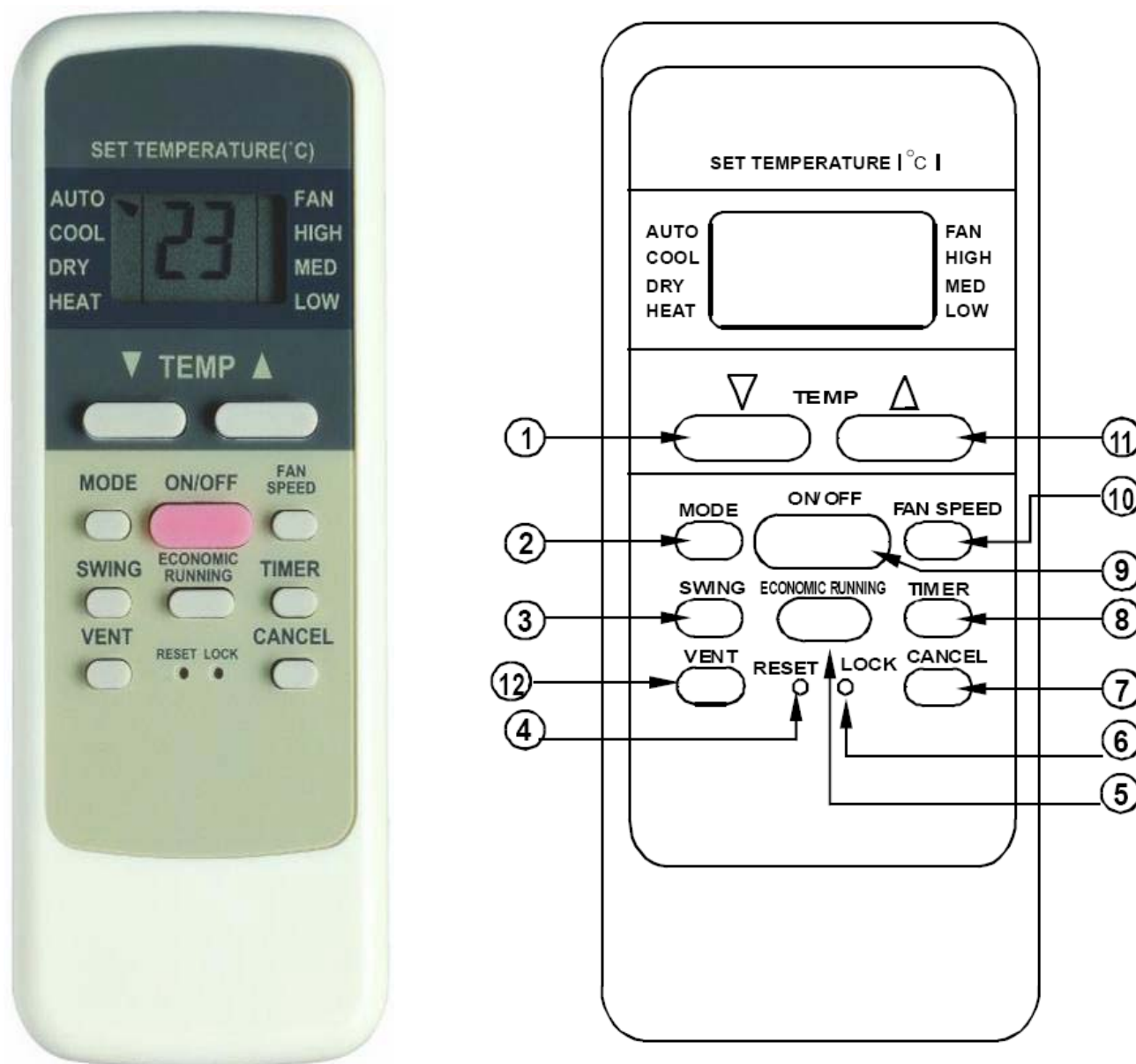

Fig-1

Note: This illustration is for explanation purposes only. The actual shape or button names of the remote controller may be slightly different.

① **TEMP Button:** Push the TEMP button to decrease the indoor temperature setting or to adjust the TIMER in a counter-clockwise direction.

② **MODE Select Button:** Each time you push the button, a mode is selected in a sequence that goes from AUTO、 COOL、 DRY、 HEAT and FAN as the following figure indicates:



▲ **NOTE:** HEAT only for Heat Pump

③ **SWING Button:** Push this switch button to change the louver angle.

④ **RESET Button:** When the RESET button is pushed, all of the current settings are cancelled and the control will return to the initial settings.

⑤ **ECONOMIC RUNNING Button:** Push this button to go into the Energy-Saving operation mode.

⑥ **LOCK Button:** Push this button to lock in all the current settings. To release settings, push again.

⑦ **CANCEL Button:** Push this button to cancel the TIMER settings.

⑧ **TIMER Button:** This button is used to preset the time ON (start to operate) and the time OFF (turn off the operation).

⑨ **ON/OFF Button:** Push this button to start the unit operation. Push the button again to stop the unit operation.

⑩ **FAN SPEED Button:** This button is used for setting Fan Speed in the sequence that goes from AUTO、 LOW 、 MED to HIGH, then back to Auto.

⑪ **TEMP Button:** Push the button to increase the indoor temperature setting or to adjust the TIMER in a clockwise direction.

⑫ **VENT Button:** Push this button to set the ventilating mode. The ventilating mode will operate in the following sequence:

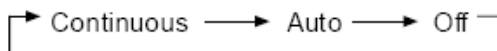

Note: ventilation function is available for the fresh air series.

1.3 Names and Functions of indicators on Remote Controller

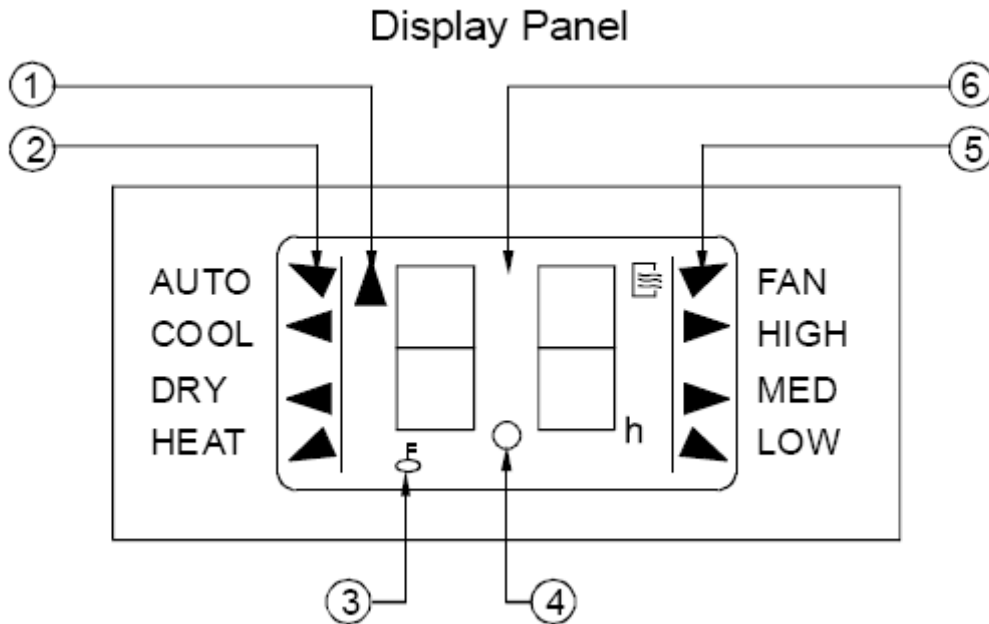

Fig-2

- ① **TRANSMISSION Indicator:** This indicator lights when remote controller transmits signals to indoor unit.
- ② **MODE Display:** Show the current operation modes-- AUTO, COOL, DRY and HEAT. HEAT is only available for heat pump model.
- ③ **HEAT PUMP ONLY - LOCK display** is displayed by pushing the LOCK button. Push the LOCK button again to clear display.
- ④ **TIMER Display:** This display area shows the settings of TIMER.
That is, if only the starting time of operation is set, it will display the TIMER ON. If only the turning off time of operation is set, it will display the TIMER OFF. If both operations are set, it will show TIMER ON OFF which indicates you have chosen to set both the starting time and off time.
- ⑤ **FAN Display:** When push the FAN button, this indicator lights.
- ⑥ **Digital Display Area:** This area will show the temperature and, if in the TIMER mode, will show the ON and OFF settings of the TIMER.

NOTE: All items are shown in the Fig-2 for the purpose of clear presentation but during the actual operation only the relative functional items are shown on the display panel.

1.4 Operating the Remote Controller

1) Install / Replace Batteries

The Remote Controller uses two alkaline dry batteries (R03/Ir03X2).

- ✘ To install batteries, slide back the cover of the battery compartment and install the batteries according to the directions (+and -) shown on the Remote Controller.
- ✘ To replace the old batteries, use the same method as mentioned above.

NOTE:

1. When replacing batteries do not use old batteries or a different type battery. This may cause the remote controller to malfunction.
2. If you do not use the remote controller for several weeks remove the batteries. Otherwise battery leakage may damage the remote controller.
3. The average battery life under normal use is about 6 months.
4. Replace the batteries when there is no answering beep from the indoor unit or if the Transmission Indicator light fails to appear.

2) AUTOMATIC OPERATION

When the Air Conditioner is ready for use, switch on the power and the OPERATION indicator lamp on the display panel of the indoor unit starts flashing.

- ✘ Use the MODE select button to select AUTO.IN the multi system, to avoid mode conflict; auto-mode is taken as cool mode.
- ✘ Push the TEMP button to set the desired room temperature.
- ✘ The most comfortable temperature settings are between 21°C and 28°C
- ✘ Push the ON/OFF button to start the air conditioner. The OPERATION lamp on the display panel of the indoor unit lights. The operating mode of AUTO FAN SPEED is automatically set and there are no indicators shown on the display panel of the remote controller.
- ✘ Push the ON/OFF button again to stop the unit operation.

NOTE:

1. In the AUTO mode, the air conditioner can logically choose the mode of COOL, FAN, HEAT and DRY by sensing the difference between the actual ambient room temperature and the set temperature on the remote controller..
2. If the AUTO mode is not comfortable for you, the desired mode can be selected manually.

3) COOL, HEAT, and FAN ONLY Operation

- ✘ If the AUTO mode is not comfortable, you may manually change the settings by using COOL, DRY, HEAT (HEAT PUMP units only), or FAN ONLY modes.
- ✘ Push the TEMP button to set the desired room temperature.
- ✘ When in COOLING mode, the most comfortable settings are 21°C or above. When in HEATING mode, the most comfortable settings are 28°C or below.
- ✘ Push the FAN SPEED to select the FAN mode of AUTO, HIGH, MED or LOW.
- ✘ Push the ON/OFF button. The operation lamp lights and the air conditioner start to operate per your settings. Push the ON/OFF button again to stop this unit operation.

NOTE:

The FANONLY mode cannot be used to control the temperature. While in this mode, only steps1、 3 and 4 may be performed.

4) DRY OPERATION

- ✘ Push the MODE button to select DRY.
- ✘ Push the TEMP button to set the desired temperature from 21°C to 28°C.
- ✘ Push the ON/OFF button. The operation lamp lights and the air conditioner start to operate in the DRY mode. Push the ON/OFF button again to stop this unit operation.

NOTE:

Due to the difference of the set temperature of the unit and the actual indoor temperature, the Air Conditioner when in DRY mode will automatically operate many times without running the COOL and FAN mode.

5) TIMER OPERATION

PUSH TIMER button to set the on and off times of the unit.

a. To set the STARTING time.

- ✘ Please push the CANCEL button to cancel any former settings.
- ✘ Push the TIMER button. The remote controller will show the TIMER and the signal "h" is shown on the display panel. The control is now ready to reset the TIMER ON to start the operation.
- ✘ Push the TEMP button (▼ or ▲) to set desired unit START time.
- ✘ After setting the TIMER there will be a one-half second delay before the remote controller transmits the signal to the Air Conditioner. Then, after approximately another 2 seconds, the set temperature will re-appear on the digital display.

b. To set the STOPPING time.

- ✘ Please press the CANCEL button to cancel any former settings.
- ✘ Push the TIMER button and the remote controller will show the last set time for the START operation and the signal "h" will be shown on the display panel. You are now ready to readjust the TIMER OFF to stop the operation.
- ✘ Push the TEM button to cancel the TIMER ON setting. The digital area will show "00".
- ✘ Push the TIMER button and the remote controller will show the last set time for the STOP operation and the signal "h" will be shown on the display panel. You are now ready to reset the time of the STOP operation.
- ✘ Push the TEMP button (▼ or ▲) to set the time you want to stop the operation.
- ✘ After setting the TIMER there will be a one-half second delay before the remote controller transmits the signals to the Air Conditioner. Then after approximately another 2 seconds, the set temperature will re-appear on the digital display.

c. Set the STARTING & STOPPING time

- ✘ Please press the CANCEL button to cancel any former settings.
- ✘ Push the TIMER button and the remote controller will show the last set time for START operation and the signal "h" will be shown on the display panel. You are now ready to readjust the TIMER ON to start the operation.
- ✘ Push the TEMP button (▼ or ▲) to set the time you want to start the operation.
- ✘ Push the TIMER button and the remote controller will show the last set time for STOP operation and the signal "h" will be shown on the display panel. You are now ready to reset the time of the STOP operation.
- ✘ Push the TEMP button (▼ or ▲) to set the time you want to stop the operation.
- ✘ After setting the TIMER there will be a one-half second delay before the remote controller transmits the signal to the Air Conditioner. Then, after approximately another 2 seconds, the set temperature will re-appear on the digital display.

NOTE:

1. Please reset the TIMER after cancelling the former time settings.
2. The setting time is relative time. That is the time set is based on the delay of the current time.

Warning

1. Be sure there are no barriers between the remote controller and the receiver of indoor unit otherwise the air conditioner will not work.
2. Keep the Remote Controller away from liquids.
3. Protect the Remote Controller from high temperatures and exposure to radiation.
4. Keep the indoor receiver out of direct sunlight or the Air Conditioner may malfunction.
5. Keep controller away from EMI (Electro-Magnetic Interference) supplied by other household appliances.

2. Wired controller (Optional)

KJR-10B

1) Outlook

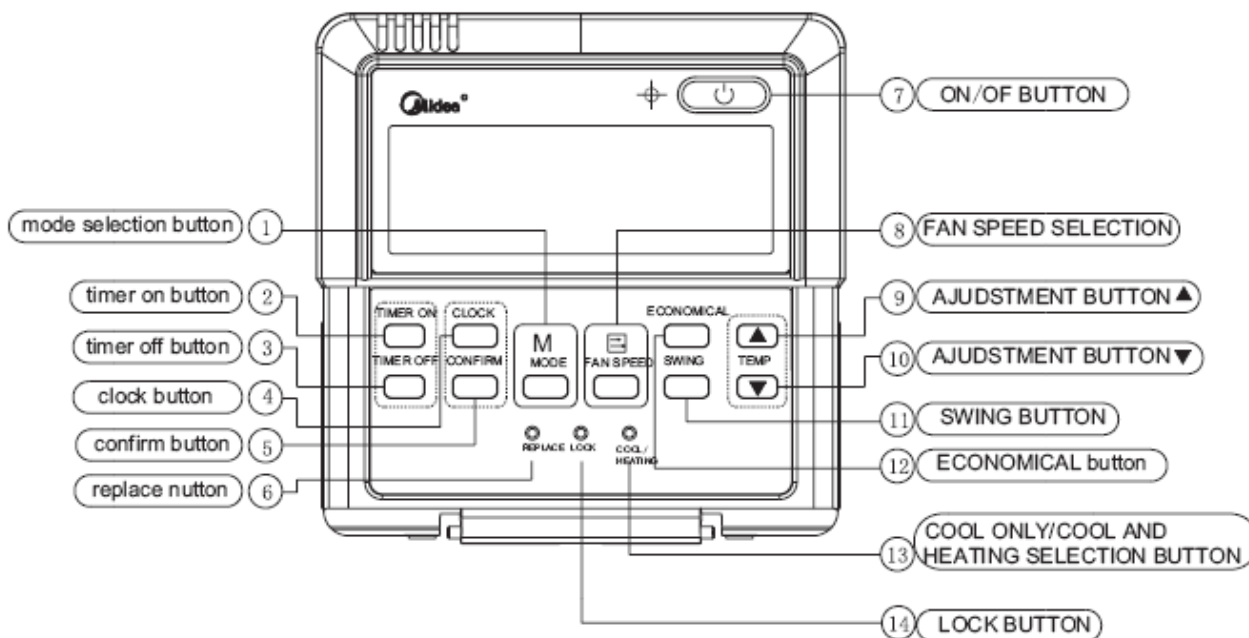

2) Installation

Wiring Principle Sketch:

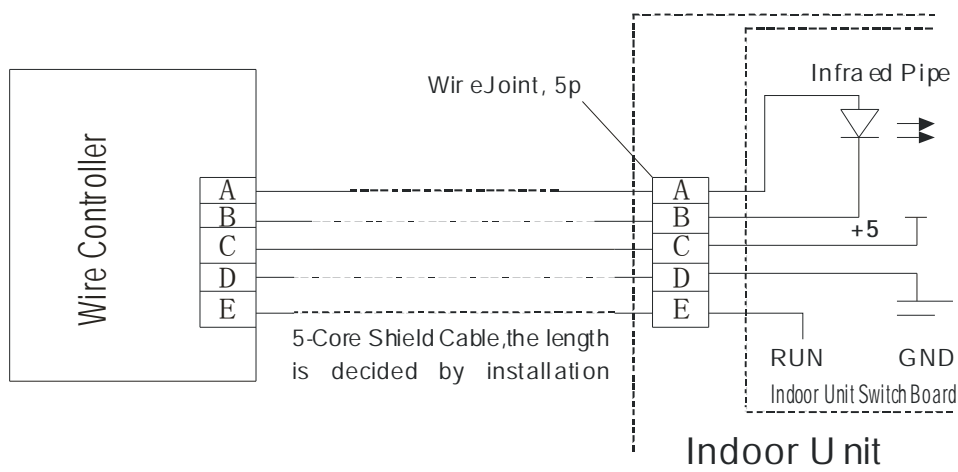

Note:

When the air conditioner needs the constant frequency wire Controller. Be sure adding a Wire Joint with 5 terminal named A, B, C, D, E in indoor unit. And fixing a infrared emitter whose anode and cathode connecting with A and B near the receiver in the Indoor Unit Switch Board, then connecting the terminal +5V, GND, Run in the Switch Board to C, D, E respectively.

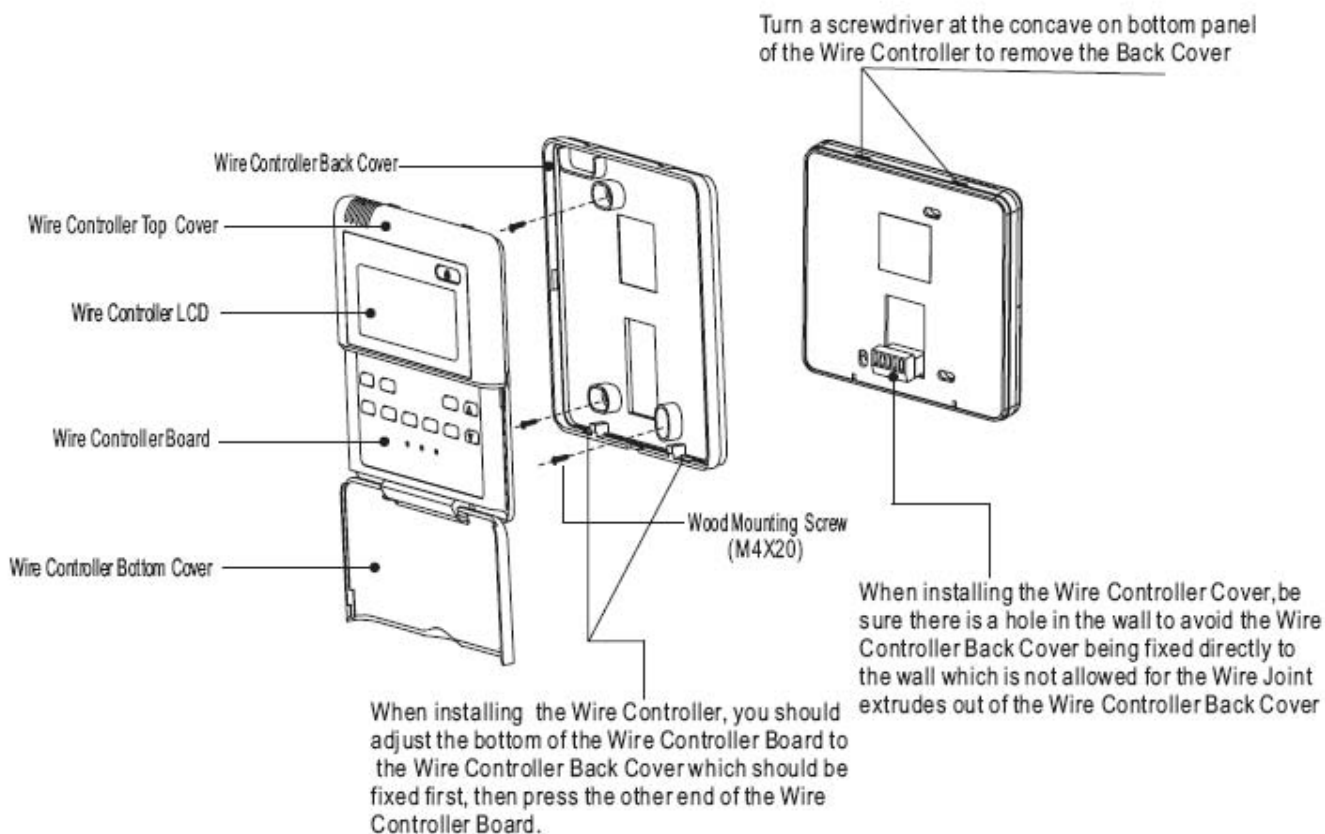

Note:

1. Never turn screws too tightly, or else the cover would be dented or the Liquid Crystal breaks.
2. Please leave enough long cable for maintenance of the Wire Controller Board.

3. Central Control Monitor (Optional)

CCM03

1) Outlook



Buttons and Functions

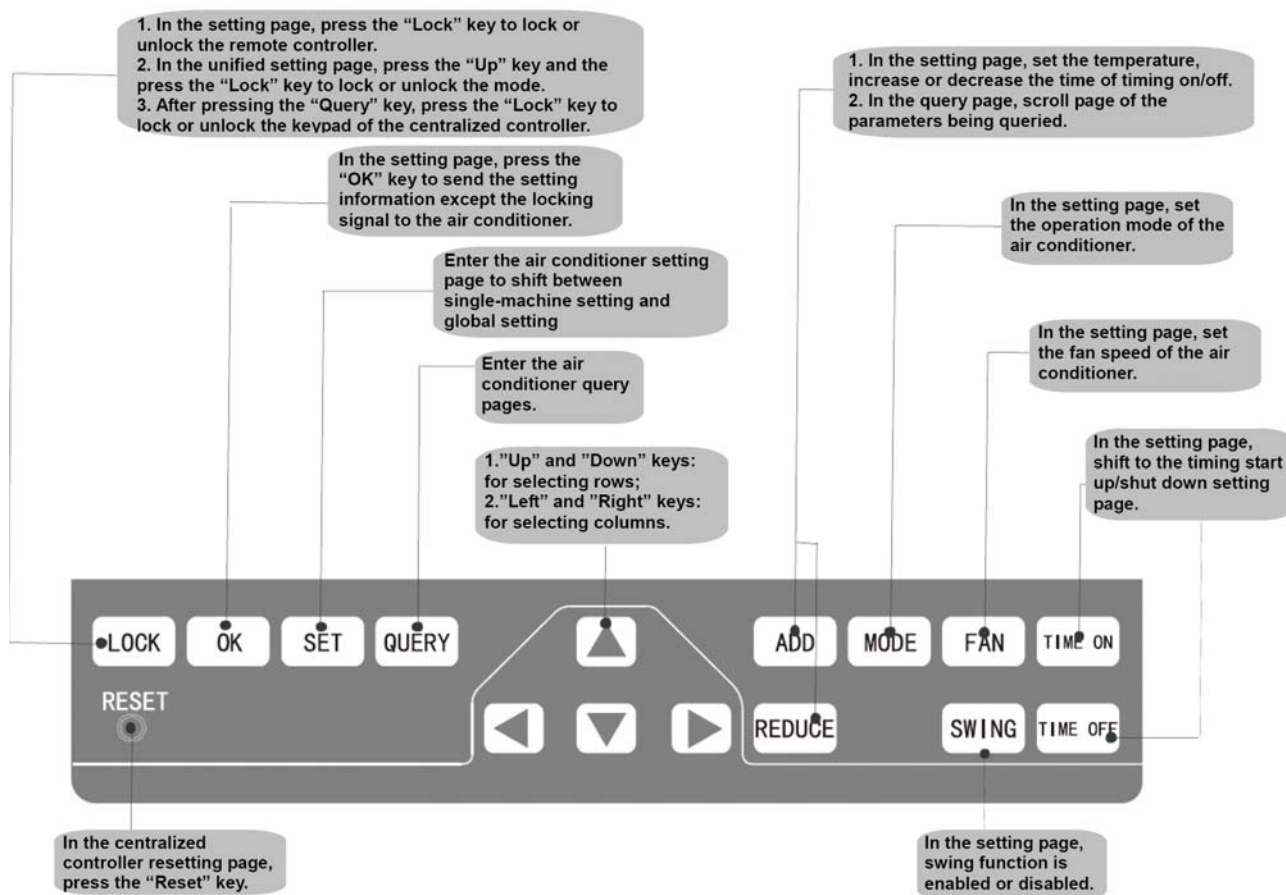

Liquid Crystal Display:

Full display of LCD

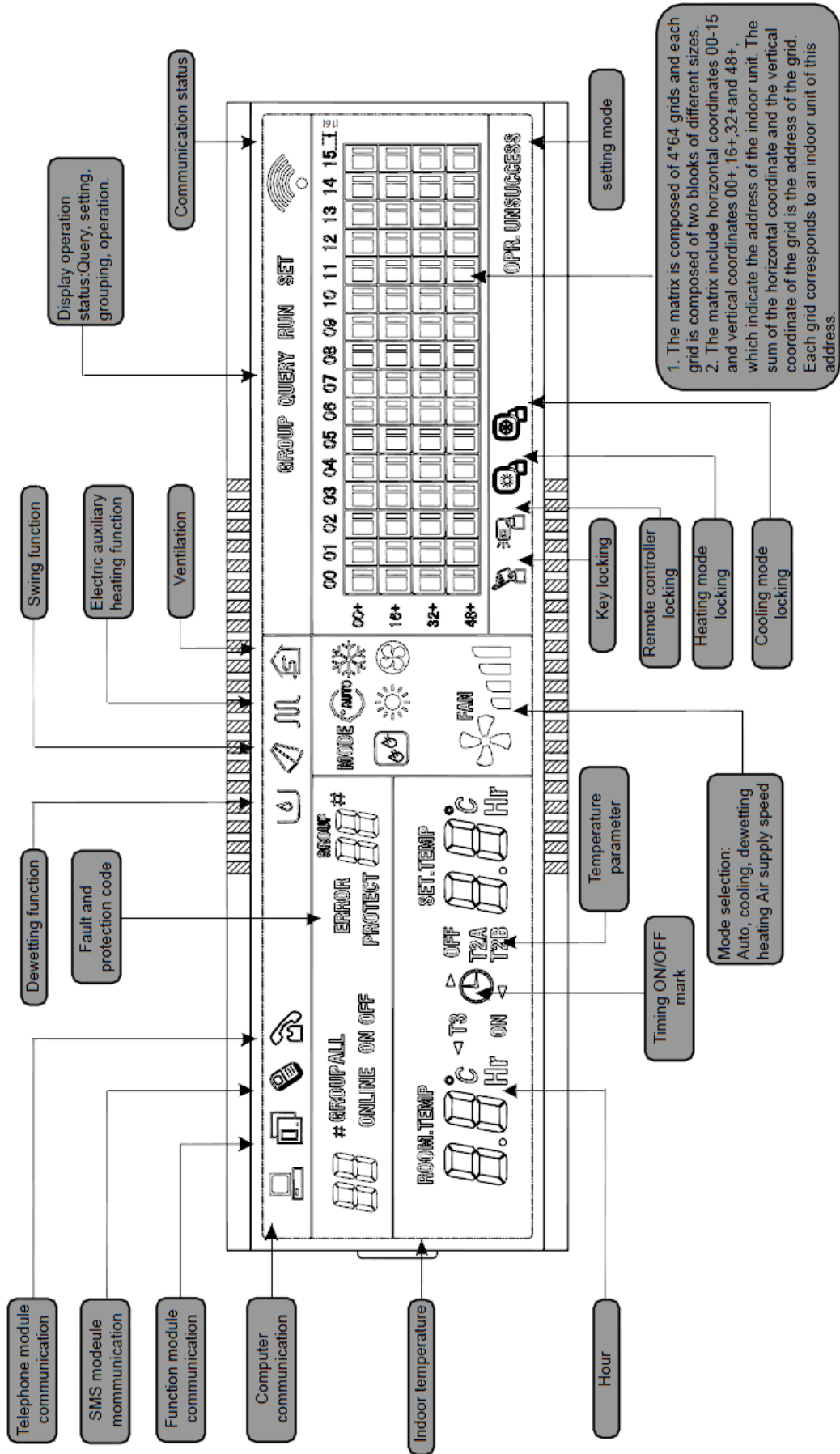

2) Installation

Installation dimensions:
As shown in the figure on the right side.

Installation screw holes (4 holes)

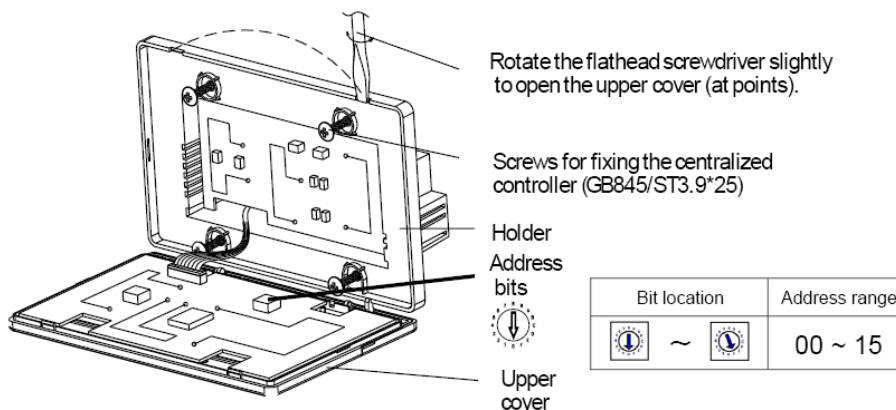
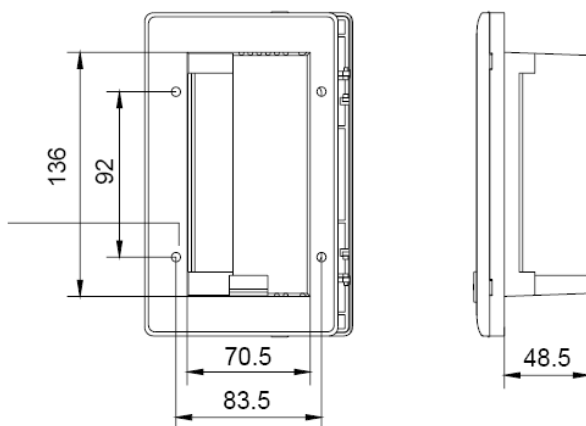

Note: To differentiate each centralized controller, the controllers in the same RS-485 net should be with different address with each other.

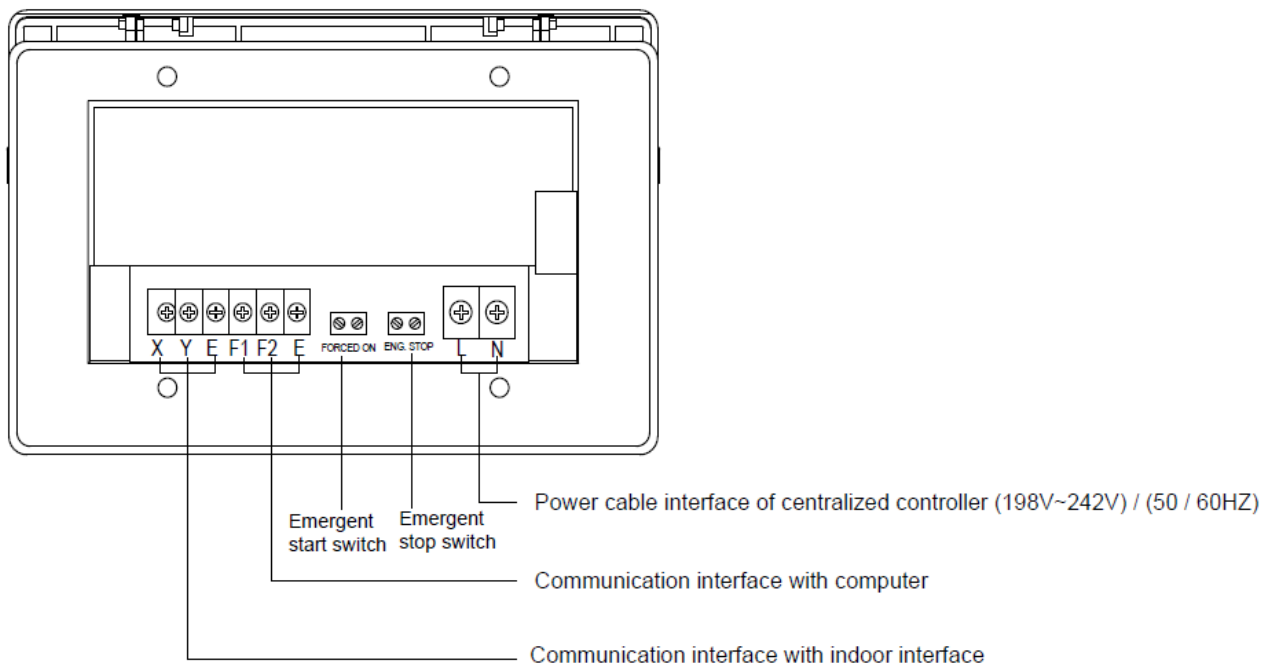

NOTE:

1. Never turn screws too tightly, otherwise the cover would be dented, or the Liquid Crystal would be broken.
2. Do not cut wires when installing the cover of Central Control Monitor.

Appendix 1: Indoor Temp. and Pipe Temp. Sensor Resistance Value Table (°C--K)

°C	K Ohm	°C	K Ohm	°C	K Ohm	°C	K Ohm
-20	115.266	20	12.6431	60	2.35774	100	0.62973
-19	108.146	21	12.0561	61	2.27249	101	0.61148
-18	101.517	22	11.5000	62	2.19073	102	0.59386
-17	96.3423	23	10.9731	63	2.11241	103	0.57683
-16	89.5865	24	10.4736	64	2.03732	104	0.56038
-15	84.2190	25	10.0000	65	1.96532	105	0.54448
-14	79.3110	26	9.55074	66	1.89627	106	0.52912
-13	74.5360	27	9.12445	67	1.83003	107	0.51426
-12	70.1698	28	8.71983	68	1.76647	108	0.49989
-11	66.0898	29	8.33566	69	1.70547	109	0.48600
-10	62.2756	30	7.97078	70	1.64691	110	0.47256
-9	58.7079	31	7.62411	71	1.59068	111	0.45957
-8	56.3694	32	7.29464	72	1.53668	112	0.44699
-7	52.2438	33	6.98142	73	1.48481	113	0.43482
-6	49.3161	34	6.68355	74	1.43498	114	0.42304
-5	46.5725	35	6.40021	75	1.38703	115	0.41164
-4	44.0000	36	6.13059	76	1.34105	116	0.40060
-3	41.5878	37	5.87359	77	1.29078	117	0.38991
-2	39.8239	38	5.62961	78	1.25423	118	0.37956
-1	37.1988	39	5.39689	79	1.21330	119	0.36954
0	35.2024	40	5.17519	80	1.17393	120	0.35982
1	33.3269	41	4.96392	81	1.13604	121	0.35042
2	31.5635	42	4.76253	82	1.09958	122	0.3413
3	29.9058	43	4.57050	83	1.06448	123	0.33246
4	28.3459	44	4.38736	84	1.03069	124	0.32390
5	26.8778	45	4.21263	85	0.99815	125	0.31559
6	25.4954	46	4.04589	86	0.96681	126	0.30754
7	24.1932	47	3.88673	87	0.93662	127	0.29974
8	22.5662	48	3.73476	88	0.90753	128	0.29216
9	21.8094	49	3.58962	89	0.87950	129	0.28482
10	20.7184	50	3.45097	90	0.85248	130	0.27770
11	19.6891	51	3.31847	91	0.82643	131	0.27078
12	18.7177	52	3.19183	92	0.80132	132	0.26408
13	17.8005	53	3.07075	93	0.77709	133	0.25757
14	16.9341	54	2.95896	94	0.75373	134	0.25125
15	16.1156	55	2.84421	95	0.73119	135	0.24512
16	15.3418	56	2.73823	96	0.70944	136	0.23916
17	14.6181	57	2.63682	97	0.68844	137	0.23338
18	13.9180	58	2.53973	98	0.66818	138	0.22776
19	13.2631	59	2.44677	99	0.64862	139	0.22231