



# Light Commercial SUPER INVERTER SERIES MULTI TYPE Service Manual

## Models

Cassette

MCA3I(U)-07/09/12/18HRF(D)N1-Q

MSP Duct

MTBI(U)-07/09/12/18HWF(D)N1-Q



---

## CONTENTS

<b>1. GENERAL INFORMATION OF INDOOR UNITS.....</b>	<b>3</b>
<b>2. FEATURES .....</b>	<b>4</b>
<b>3. SPECIFICATION.....</b>	<b>10</b>
<b>4. DIMENSIONS.....</b>	<b>14</b>
<b>5. SERVICE SPACE (UNIT: MM).....</b>	<b>16</b>
<b>6. WIRING DIAGRAM.....</b>	<b>18</b>
<b>7. STATIC PRESSURE (DUCT).....</b>	<b>20</b>
<b>8. OPERATION TEMPERATURE RANGE .....</b>	<b>22</b>
<b>9. ELECTRONIC FUNCTION .....</b>	<b>23</b>

※The specifications, designs, and information in this book are subject to change without notice for product improvement.

## 1. General information of Indoor Units

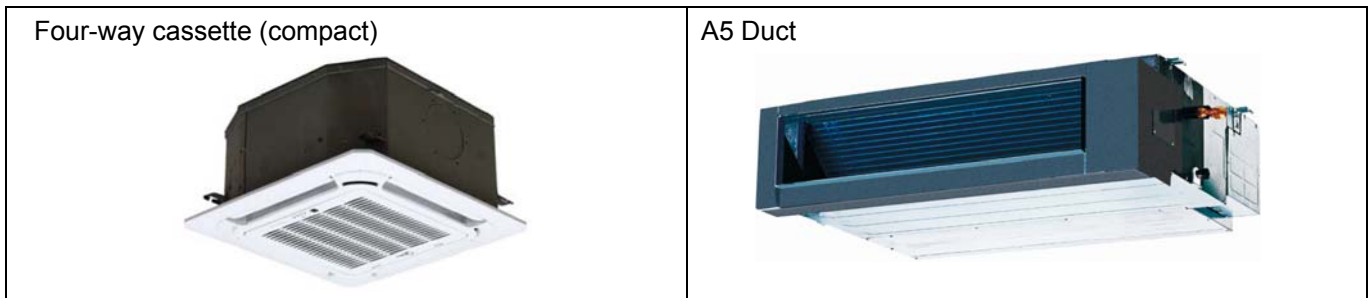

Model name	Dimension (mm)	Net/Gross weight (kg)
MTBI-07HWFN1-Q	700x635x210	19.5/24.5
MTBI-09HWFN1-Q	700x635x210	19.5/24.5
MTBU-12HWFN1-Q	700x635x210	18/22.8
MTBI-18HWDN1-Q	920x635x210	23/29
MCA3I-07HRFN1-Q	570x570x260	14.5/17.3
MCA3I-09HRFN1-Q	570x570x260	14.5/17.3
MCA3U-12HRFN1-Q	570x570x260	16/19
MCA3I-18HRDN1-Q	570x570x260	18/21

## 2. Features

### 2.1 Four-way cassette type(compact)

#### (1) New panel

- 360°surrounding air outlet design, affords comfortable feeling



#### (2) Compact design

- The body size is 570×260×570mm, it's just smaller than the ceiling board, so it's very easy for installation and will not damage the decoration. The panel size is 647×50×647mm.
- The hooks are designed in the four corners of the body, which can save installation space.



#### (3) Electric control box built-in design

- The E-box is simply and safely built inside the indoor unit. It's convenient for installation and maintenance. Can check the control part easily, you only need to open the air return grille.



**(4) Fresh air intake function:**

- Fresh air fulfills air quality more healthy and comfortable.

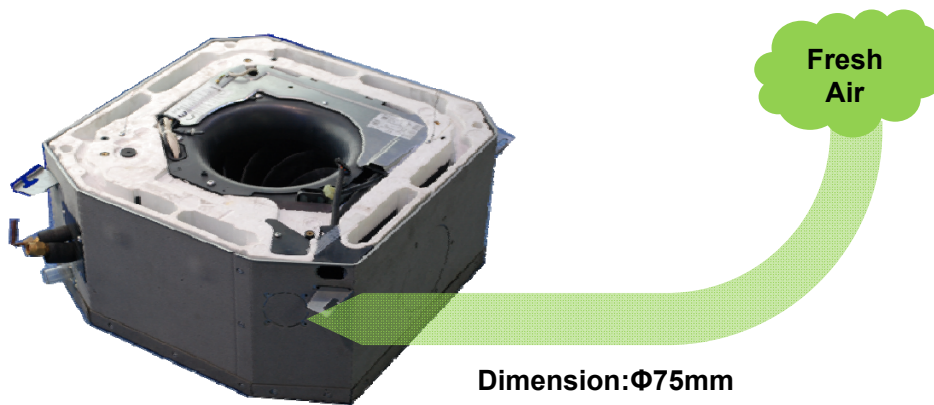
**(5) Air passage function**

- Reserves the space for air outlet from the side of indoor unit; It's availed to connect air duct from the two sides to the nearby small rooms.



## 2.2 MSP Duct

### (1) Easy Installation: Two air inlet styles (Bottom side or Rear side)

- Air inlet from rear is standard for all capacity; air inlet from bottom is optional.
- The size of air inlet frame from rear and bottom is same, it's very easy to move the cover from bottom to rear side, or from rear to the bottom, in order to matching the installation condition.



Air intake from rear (Standard)

Air intake from bottom (Optional)



### (2) Fresh air intake function

- Install one duct from the reserved fresh-air intake to outdoor.  
Continually inhale the fresh air to improve the quality of the indoor air, fulfills air quality more healthy and comfortable.

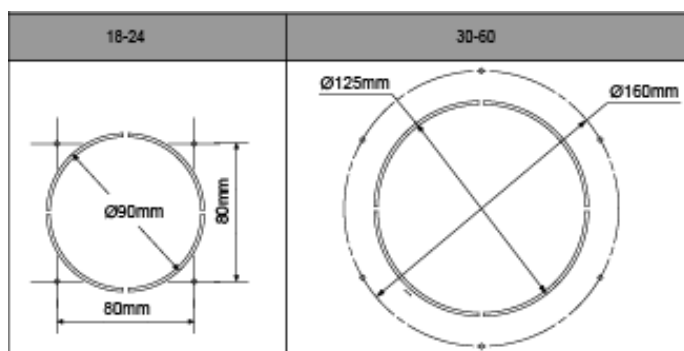

### (3) Easy maintenance

- Clean the filter (Optional, standard product without filter)  
It is easy to draw out the filter from the indoor unit for cleaning, even the filter is installed in rear side or bottom side.



➤ **Replace the motor or centrifugal fan**

Remove the ventilated panel firstly. Remove a half of blower housing and take out the motor with centrifugal fan. Directly remove two bolts, and then replace the motor or centrifugal fan easily.

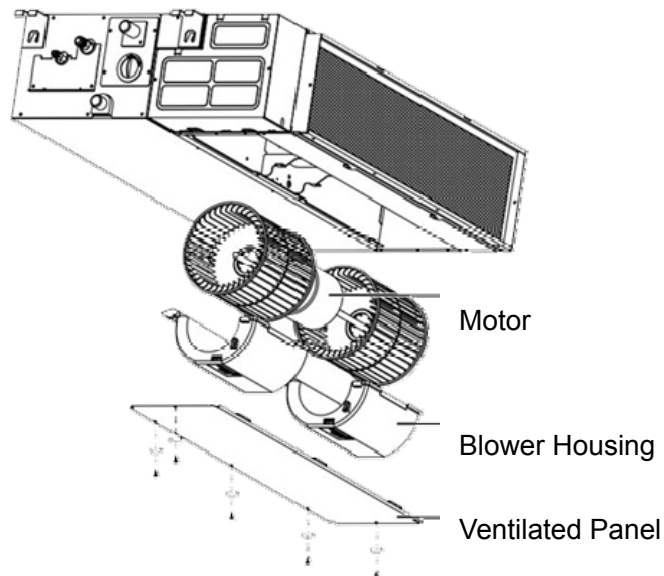

**(4) Reserved remote on-off and central control ports**

- Reserved remote on-off ports and central control ports, can connect the cable of an on-off controller or a central controller to realize remote on-off control function or group control function.

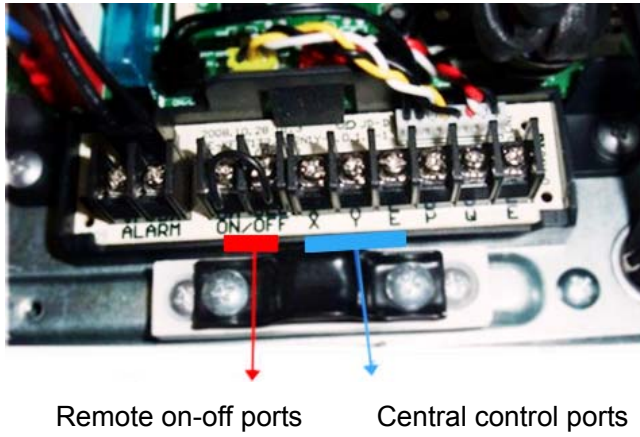

**(5) Built-in drain pump (Optional):**

- Built-in drain pump can lift the water to 750mm upmost. It's convenient to install drainage piping under most space condition.

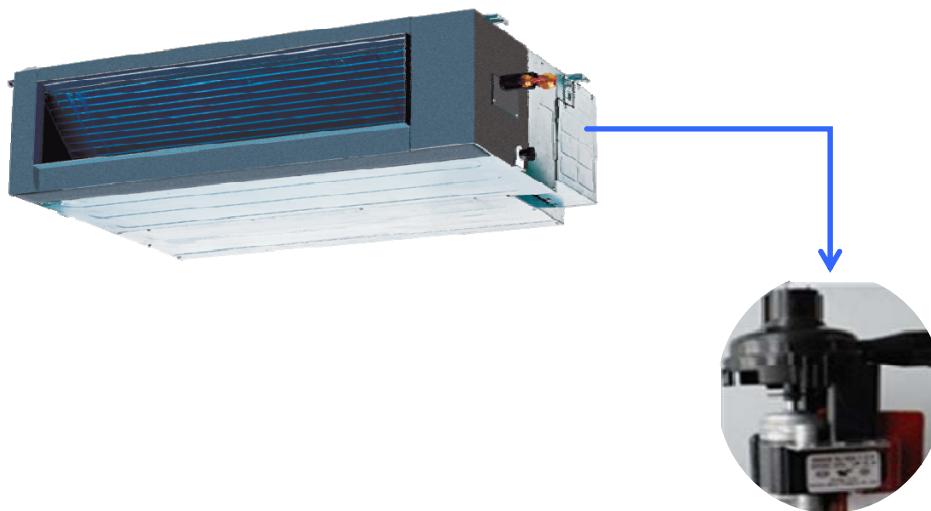
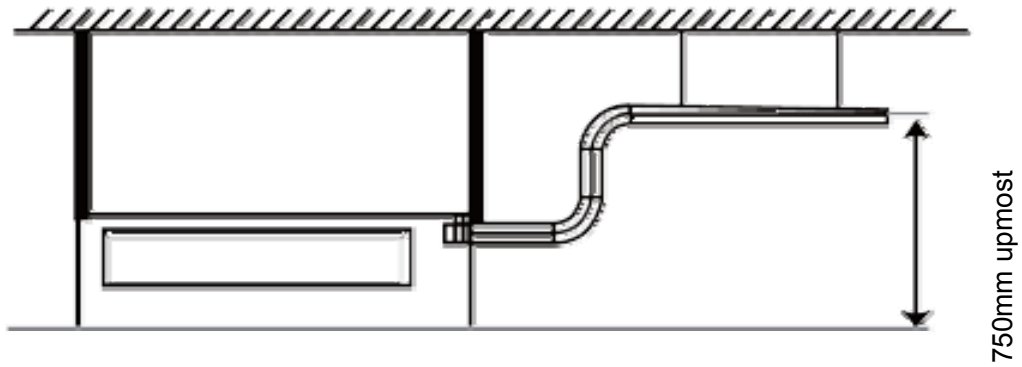



**(6) Built-in display board**

- The standard indoor unit can be controlled by wired controller.
- There is a display board with a receiver in the E-box. Move out the display, and fix it in other place, even in the distance of 10m. The unit will realized remoter control.
- The wired controller and the display board can display the error code or production code when the chips detect some failure.

Wired Controller (Standard)

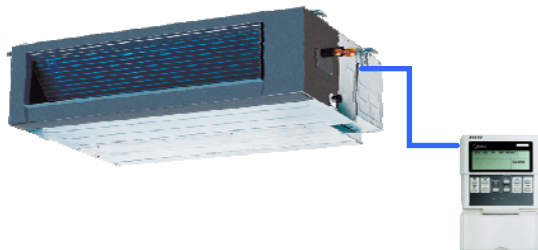

Remote Controller (Optional)

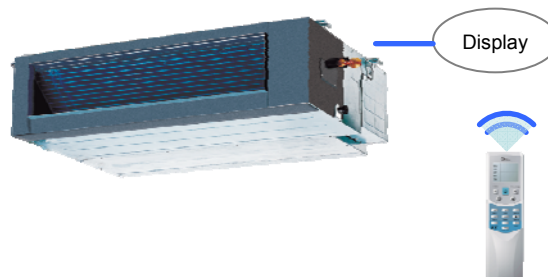

### 3. Specification

#### Cassette type

Model			MCA3I-07HRFN1-Q	MCA3I-09HRFN1-Q
Decorative panel			T-MBQ-03D1	T-MBQ-03D1
Power supply		V-ph-Hz	220-240-1-50	220-240-1-50
Cooling	Capacity	kW	2,05	2,64
	Input	W	40	40
	Rated current	A	0,18	0,18
Heating	Capacity	kW	2,34	2,93
	Input	W	40	40
	Rated current	A	0,18	0,18
Indoor fan motor	Model		WZDK46-38G	WZDK46-38G
	Qty		1	1
	Input	w	46(Output)	46(Output)
	Capacitor	uF	----	----
	Speed(hi/mi/lo)	r/min	730/620/560	730/620/560
Indoor coil	a.Number of rows		1	1
	b.Tube pitch(a)x row pitch(b)	mm	21x13.37	21x13.37
	c.Fin spacing	mm	1,3	1,3
	d.Fin type (code)		Hydrophilic aluminium	Hydrophilic aluminium
	e.Tube outside dia.and type	mm	Φ7,inner grooved tube	Φ7,inner grooved tube
	f.Coil length x height x width	mm	1380x210x13.37	1380x210x13.37
	g.Number of circuits		2	2
Indoor air flow		m3/h	580/500/450	580/500/450
Indoor sound pressure level		dB(A)	42/38/35	42/38/35
Indoor sound power level		dB(A)	53	53
Indoor unit	Dimension (W x Dx H)(body)	mm	570x570x260	570x570x260
	Packing (W x Dx H)(body)	mm	655x655x290	655x655x290
	Dimension (W x Dx H)(panel)	mm	647x647x50	647x647x50
	Packing (W x Dx H)(panel)	mm	715x715x123	715x715x123
	Net/Gross weight(body)	kg	14.5/17.3	14.5/17.3
	Net/Gross weight	kg	2.5/4.5	2.5/4.5
Design pressure		MPa	4.2/1.5	4.2/1.5
Drainage water pipe dia.		mm	ODΦ25	ODΦ25
Refrigerant piping	Liquid side/ Gas side	mm	Φ6.35/Φ9.52(1/4"/3/8")	Φ6.35/Φ9.52(1/4"/3/8")
Controller			RG36C/BG(C)E	RG36C/BG(C)E
Room temperature	Cooling	℃	17-32	17-32
	Heating	℃	0-30	0-30
Operation temperature		℃	17-30	17-30

Model			MCA3U-12HRFN1-Q	MCA3I-18HRDN1-Q
Decorative panel			T-MBQ-03D1	T-MBQ-03D1
Power supply		V-ph-Hz	220-240-1-50	220-240-1-50
Cooling	Capacity	kW	3,52	5,28
	Input	W	40	102
	Rated current	A	0,18	0,44
Heating	Capacity	kW	4,10	5,28
	Input	W	40	102
	Rated current	A	0,18	0,44
Indoor fan motor	Model		WZDK46-38G	YDK27-4P
	Qty		1	1
	Input	w	46(Output)	71/51/37
	Capacitor	uF	----	2UF/450V
	Speed(hi/mi/lo)	r/min	700/580/500	835/670/560
Indoor coil	a.Number of rows		2	2
	b.Tube pitch(a)x row pitch(b)	mm	21x13.37	21x13.37
	c.Fin spacing	mm	1,3	1,3
	d.Fin type (code)		Hydrophilic aluminium	Hydrophilic aluminium
	e.Tube outside dia.and type	mm	Φ7,inner grooved tube	Φ7,inner grooved tube
	f.Coil length x height x width	mm	1360x210x26.74	1360x210x26.74
	g.Number of circuits		4	4
Indoor air flow		m3/h	/	/
Indoor sound pressure level		dB(A)	41/37/34	48/42/36
Indoor sound power level		dB(A)	/	/
Indoor unit	Dimension (W x Dx H)(body)	mm	570x570x260	570x570x260
	Packing (W x Dx H)(body)	mm	655x655x290	655x655x290
	Dimension (W x Dx H)(panel)	mm	647x647x50	647x647x50
	Packing (W x Dx H)(panel)	mm	715x715x123	715x715x123
	Net/Gross weight(body)	kg	16/19	18/21
	Net/Gross weight	kg	2.5/4.5	2.5/4.5
Design pressure		MPa	4.2/1.5	4.2/1.5
Drainage water pipe dia.		mm	ODΦ25	ODΦ25
Refrigerant piping	Liquid side/ Gas side	mm	Φ6.35/Φ9.52(1/4"/3/8")	Φ6.35/Φ12.7(1/4"/1/2")
Controller			RG36C/BG(C)E	RG36C/BG(C)E
Room temperature	Cooling	℃	17-32	17-32
	Heating	℃	0-30	0-30
Operation temperature		℃	17-30	17-30

**MSP Duct type**

Model			MTBI-07HWFN1-Q	MTBI-09HWFN1-Q
Power supply		V-ph-Hz	220-240-1-50	220-240-1-50
Cooling	Capacity	kW	2,05	2,64
	Input	W	30	30
	Rated current	A	0,13	0,13
Heating	Capacity	kW	2,34	2,93
	Input	W	30	30
	Rated current	A	0,13	0,13
Indoor fan motor	Model		WZDK27-38GS	WZDK27-38GS
	Qty		1	1
	Input	W	27(Output)	27(Output)
	Capacitor	uF	/	/
	Speed(Hi/Med/Lo)	r/min	1150/970/900	1150/970/900
Indoor coil	Number of rows		3	3
	Tube pitch(a)*row pitch(b)	mm	21x13.37	21x13.37
	Fin spacing	mm	1,5	1,5
	Fin type		Hydrophilic aluminium	Hydrophilic aluminium
	Tube outside dia.and type	mm	Φ7,inner grooved tube	Φ7,inner grooved tube
	Coil length * height * width	mm	515x252x40.11	515x252x40.11
	Number of circuits		4	4
Indoor air flow		m3/h	530/400/340	530/400/340
ESP	Rated	Pa	25	25
	Range	Pa	0-40	0-40
Indoor sound pressure level		dB(A)	37/34/30	41/37/34
Indoor sound power level		dB(A)	55	55
Indoor unit	Dimension (WxDxH)	mm	700x635x210	700x635x210
	Packing(WxDxH)	mm	915x655x290	915x655x290
	Net/Gross weight	kg	18/22.5	18.1/22.5
Design pressure		MPa	4.2/1.5	4.2/1.5
Drainage water pipe diameter		mm	ODΦ25	ODΦ25
Refrigerant piping	Liquid side/ Gas side	mm	Φ6.35/Φ9.52(1/4"/3/8")	Φ6.35/Φ9.52(1/4"/3/8")
Controller			KJR-12B/DP(T)-E-2	KJR-12B/DP(T)-E-2
Room temperature	Cooling	℃	17-32	17-32
	Heating	℃	0-30	0-30
Operation temperature		℃	17-30	17-30

Model			MTBU-12HWFN1-Q	MTBI-18HWDN1-Q
Power supply		V-ph-Hz	220-240-1-50	220-240-1-50
Cooling	Capacity	kW	3,52	5,28
	Input	W	40	107
	Rated current	A	0,17	0,48
Heating	Capacity	kW	3,52	5,86
	Input	W	40	107
	Rated current	A	0,17	0,48
Indoor fan motor	Model		WZDK27-38GS	YSK68-4P
	Qty		1	1
	Input	W	27(Output)	107/65/52
	Capacitor	uF	/	3.5UF/450V
	Speed(Hi/Med/Lo)	r/min	1200/1070/1000	1150/800/700
Indoor coil	Number of rows		3	3
	Tube pitch(a)*row pitch(b)	mm	21x13.37	21x13.37
	Fin spacing	mm	1,5	1,5
	Fin type		Hydrophilic aluminium	Hydrophilic aluminium
	Tube outside dia.and type	mm	Φ7,inner grooved tube	Φ7, inner groove tube
	Coil length * height * width	mm	515x252x40.11	733x252x40.11
	Number of circuits		4	4
Indoor air flow		m3/h	560/440/410	816/546/-
ESP	Rated	Pa	25	25
	Range	Pa	0-40	0-60
Indoor sound pressure level		dB(A)	42/38/34	46/42/40
Indoor sound power level		dB(A)	57	59
Indoor unit	Dimension (WxDxH)	mm	700x635x210	920x635x210
	Packing(WxDxH)	mm	915x655x290	1135x655x290
	Net/Gross weight	kg	18/22.8	23/29
Design pressure		MPa	4.2/1.5	4.2/1.5
Drainage water pipe diameter		mm	ODΦ25	ODΦ25
Refrigerant piping	Liquid side/ Gas side	mm	Φ6.35/Φ9.52(1/4"/3/8")	Φ6.35/Φ12.7(1/4"/1/2")
Controller			KJR-12B/DP(T)-E-2	KJR-12B/DP(T)-E-2
Room temperature	Cooling	°C	17-32	17-32
	Heating	°C	0-30	0-30
Operation temperature		°C	17-30	17-30

## 4. Dimensions

### 4.1 Four-way cassette type (compact):

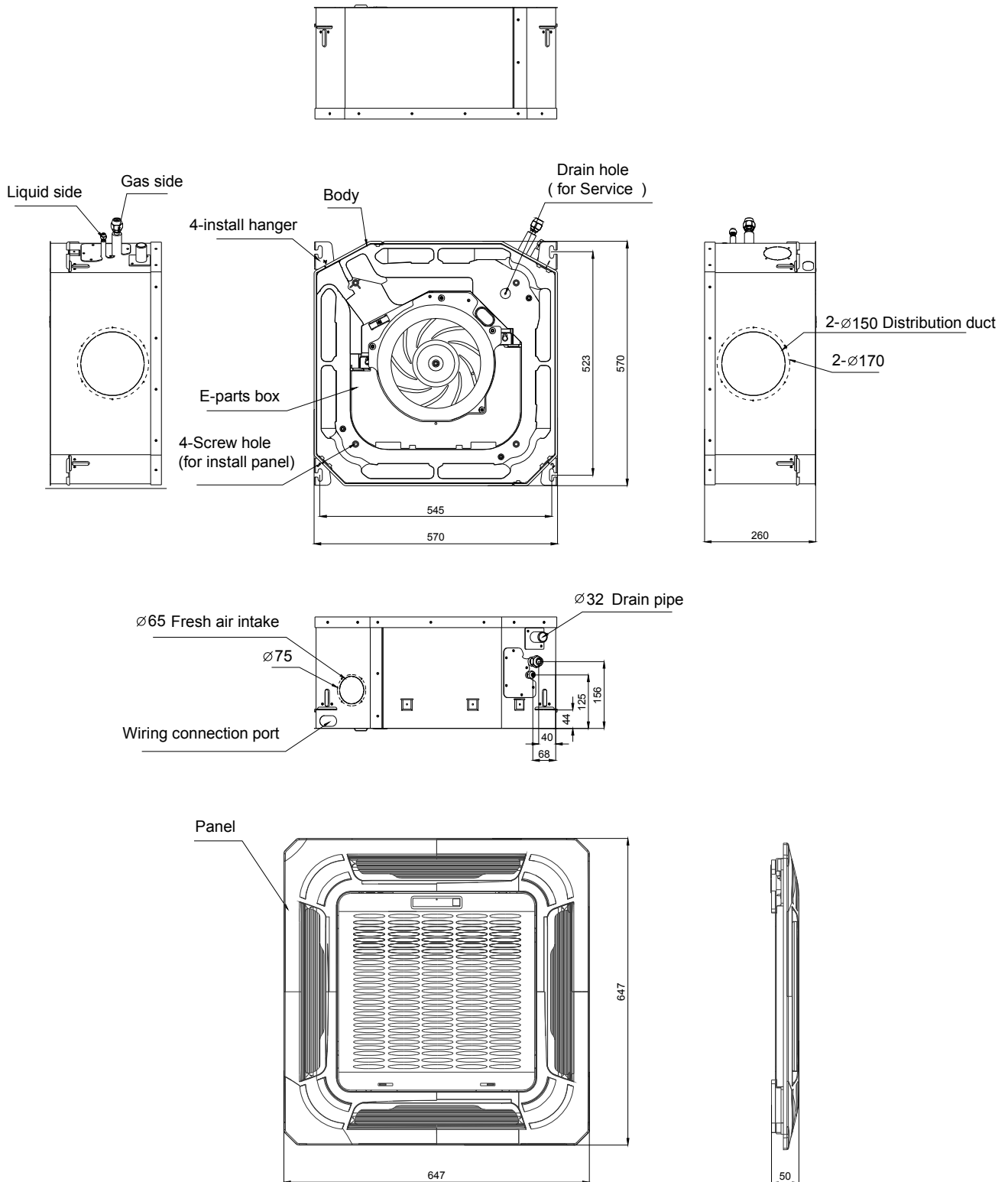

4.2 MSP Duct

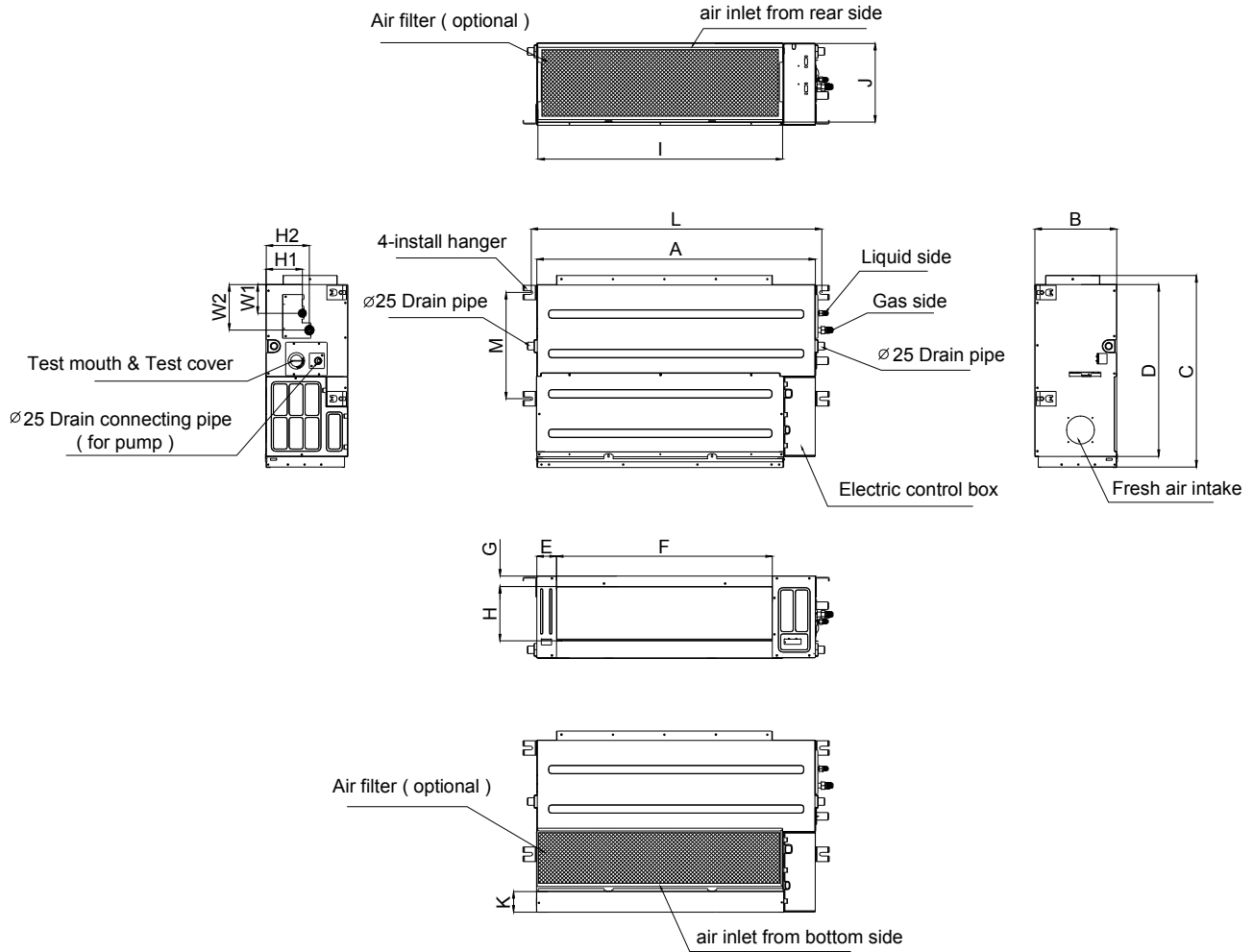

Note: standard product without filter Unit:mm

Model (K)	Outline dimension				Air outlet opening size				Air return opening size			Size of install hanger		Size of refrigerant pipe			
	A	B	C	D	E	F	G	H	I	J	K	L	M	H1	H2	W1	W2
07/09/12	700	210	635	570	65	493	35	119	595	200	80	740	350	120	143	95	150
18	920	210	635	570	65	713	35	119	815	200	80	960	350	120	143	95	150

## 5. Service Space (unit: mm)

### 5.1 Four-way cassette (compact)

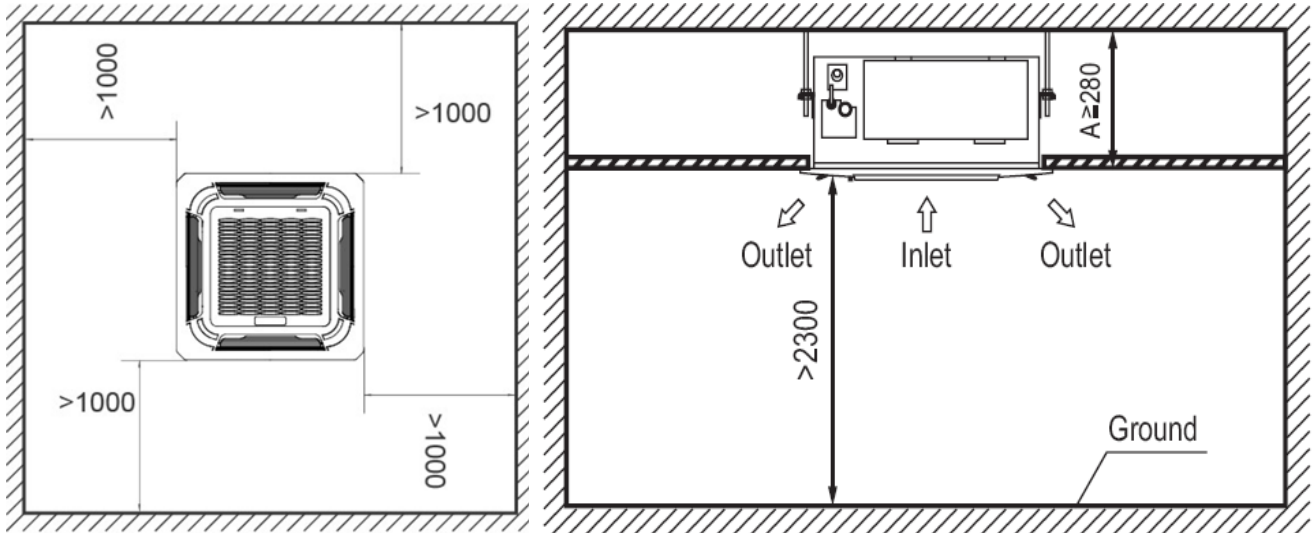

### 5.2 MSP Duct

Ensure enough space required for installation and maintenance.

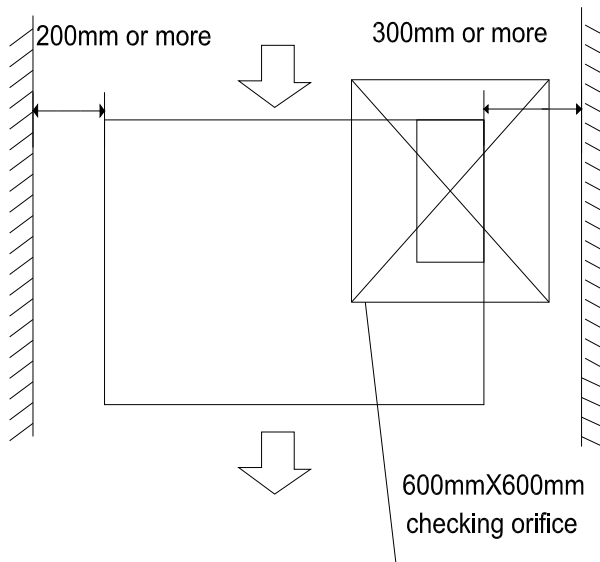

All the indoor units reserve the hole to joint the fresh air pipe. The hole size as following:

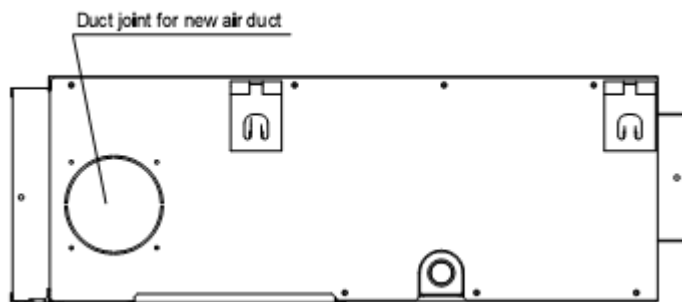



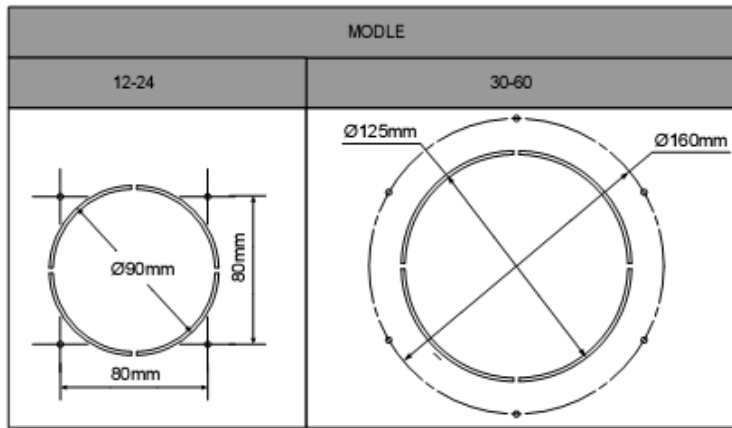



**6.3 MCA3I-07HRFN1-Q, MCA3I-09HRFN1-Q, MCA3U-12HRFN1-Q, MCA3I-18HRDN1-Q**

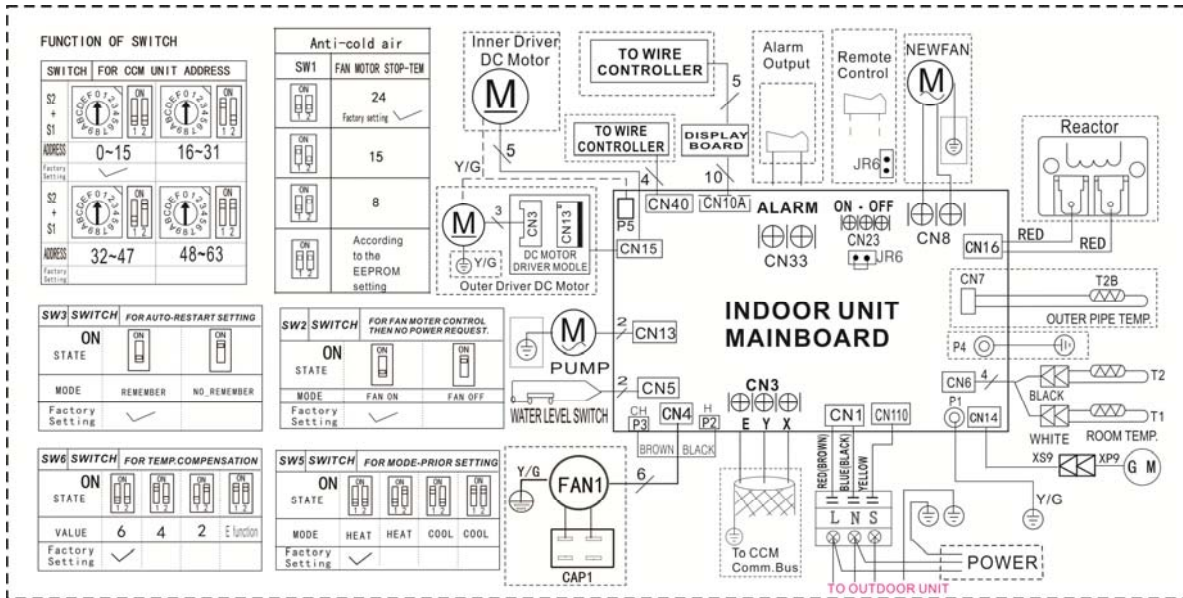

## 7. Static Pressure (Duct)

**MTBI-07HWFN1-Q, MTBI-09HWFN1-Q**

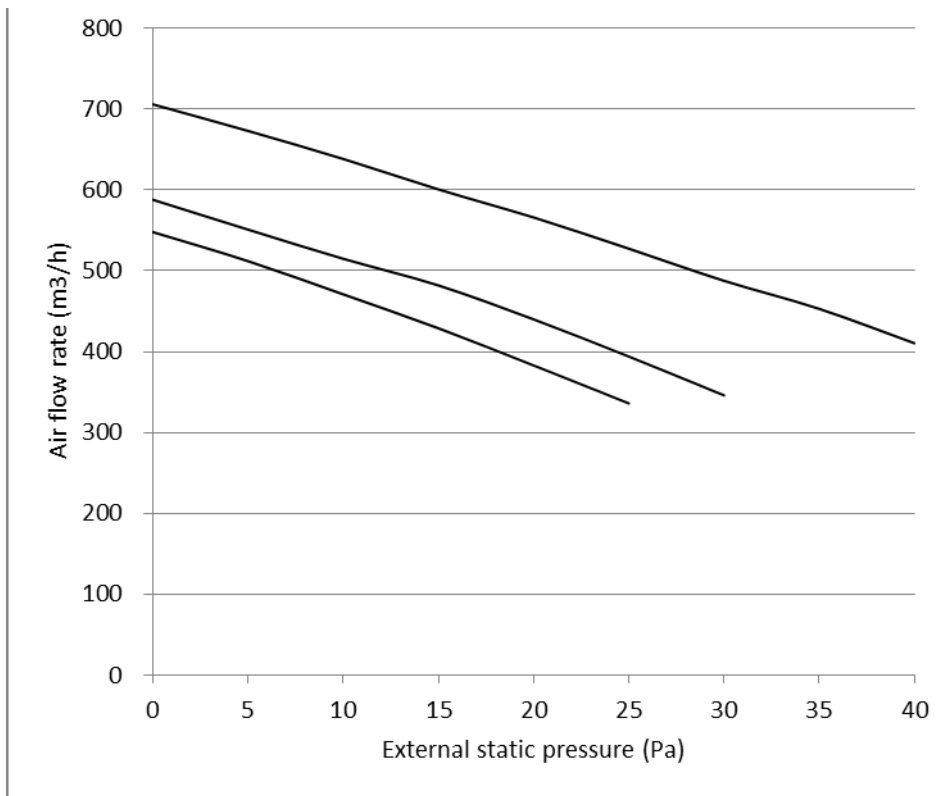

**MTBU-12HWFN1-Q**

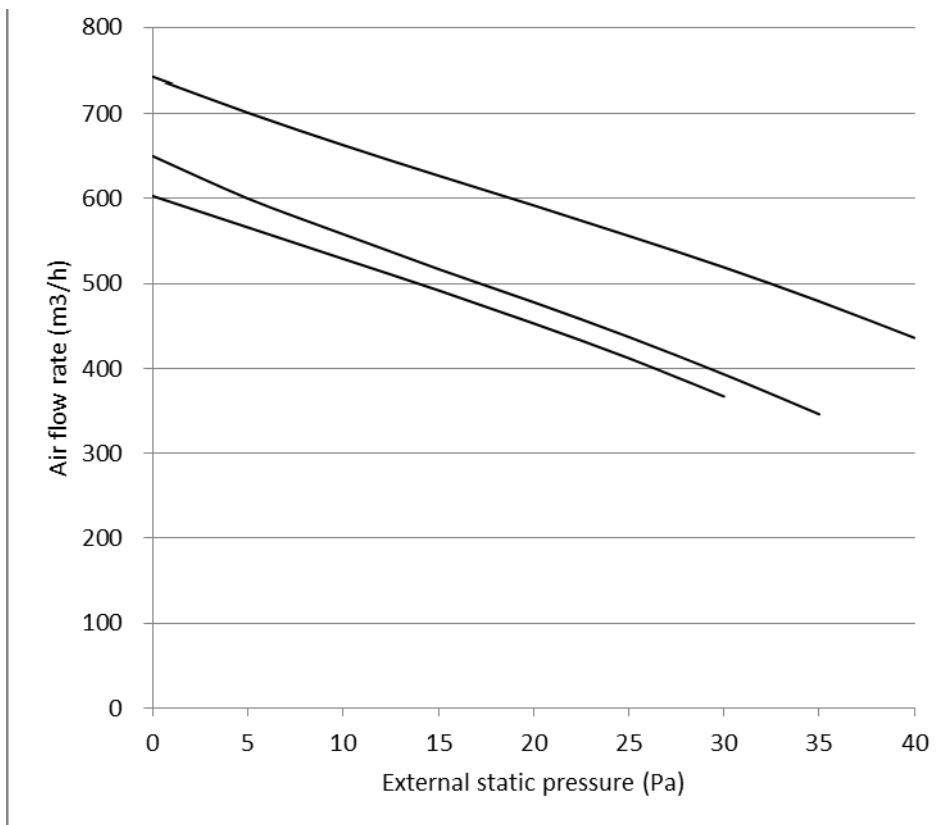

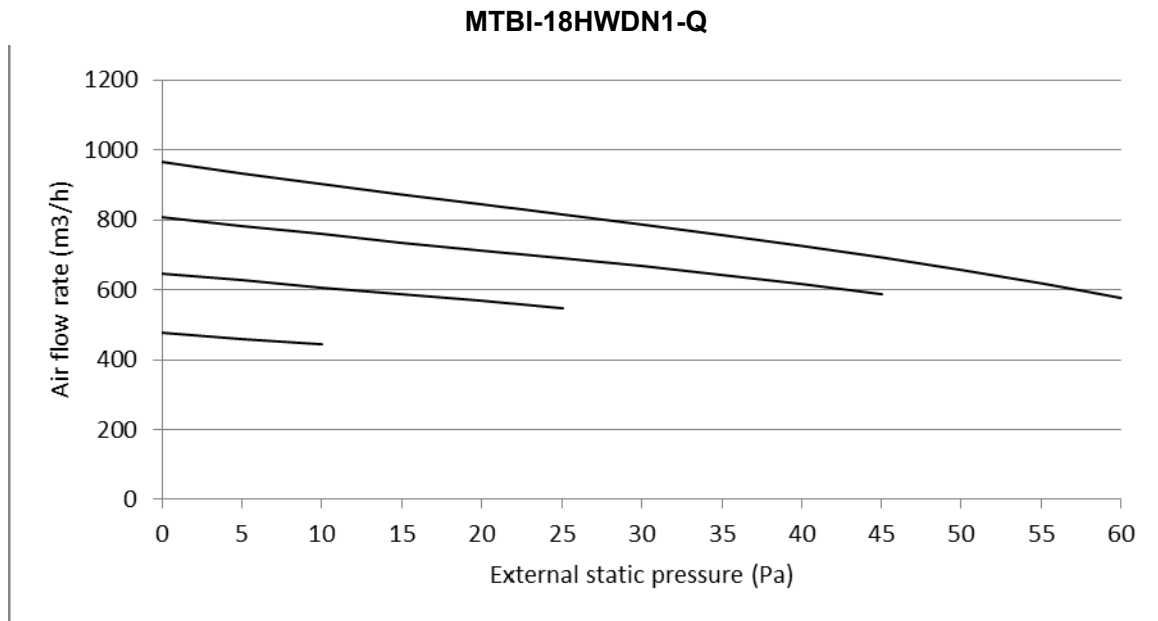

## 8. Operation temperature range

Mode \ Temperature	Cooling operation	Heating operation	Drying operation
Room temperature	17°C~32°C	0°C~30°C	17°C~32°C
Outdoor temperature	0°C~50°C	-15°C~24°C	0°C~50°C

### CAUTION:

1. If the air conditioner is used beyond the above conditions, certain safety protection features may come into operation and cause the unit to operate abnormally.
2. The room relative humidity should be less than 80%. If the air conditioner operates beyond this figure, the surface of the air conditioner may attract condensation. Please set the vertical air flow louver to its maximum angle (vertically to the floor), and set HIGH fan mode.
3. The optimum performance will be achieved during this operating temperature zone.

## 9. Electronic function

### 9.1 Abbreviation

T1: Indoor room temperature

T2: Indoor evaporator temperature

TS: Setting temperature through the remote controller

### 9.2 Icon explanation on indoor display board

#### 9.2.1 Four-way cassette (compact)

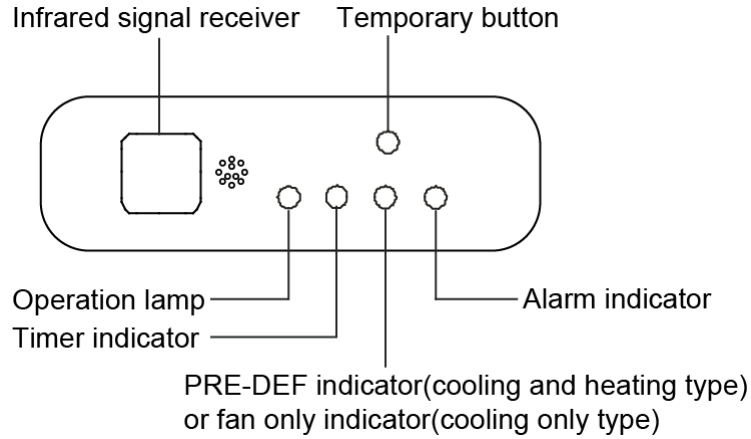

#### 9.2.2 MSP Duct

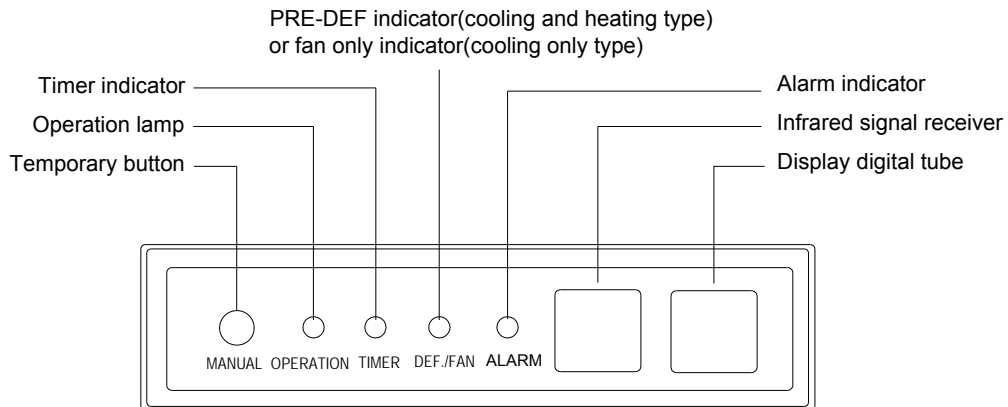

## 9.3 Main Protection

### 9.3.1 Three minutes delay at restart for compressor.

### 9.3.2 Sensor protection at open circuit and breaking disconnection.

### 9.3.3 Indoor fan delayed open function

----When system starts up, the louver will be active immediately, and the indoor fan will open after 10s.

----If the system runs in heating mode, the anti-cold wind function has priority.

### 9.3.4 Fan speed is out of control (For the units used DC fan motor)

When indoor fan speed is too low (less than 300RPM) and lasts 50 seconds, the system will consider that the fan speed is out of control and will go into fan speed protection. Then VSP signal of indoor fan will be shut off and the compressor will be also shut off if the compressor is running at that time. The louver does not act and there won't be any error code displayed. After 30 seconds, this protection will be canceled and the indoor fan will restart as well as the compressor (under the 3-minute-delay condition). As long as the fan speed is normal (no lower than 300 RPM) or fan is off, the protection will be canceled and the timing will be cleared to 0. If the protection occurs 3 times continuously, the unit will stop and LED will display failure information and can't returns to normal operation automatically.

### 9.3.5 Inverter module protection

The Inverter module has a protection function about current, voltage and temperature. If these protections happen, the corresponding code will display on indoor unit and the unit will stop working.

## 9.4 Operation Modes and Functions

### 9.4.1 Fan-only mode

(1) Outdoor fan and compressor stop.

(2) For Console: Indoor fan can be set to high/med/low/breeze, for other models: Indoor fan can be set to high/med/low/auto.

(3) The louver operates same as in cooling mode.

(4) Auto fan in fan-only mode acts as follow:

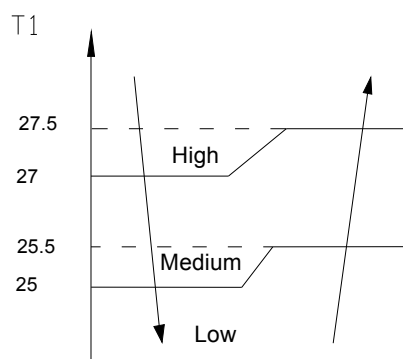

### 9.4.2 Cooling mode

#### 9.4.2.1 Compressor running rules

The compressor will run at corresponding frequency according to the gross amendatory capacity demand.



Frequency	COOL_F0	COOL_F1	COOL_F2	.....	COOL_F15	COOL_F16
Amendatory capacity demand.	0	1	2	.....	15	16

Meanwhile the maximum running frequency will be adjusted according to the outdoor ambient temp.

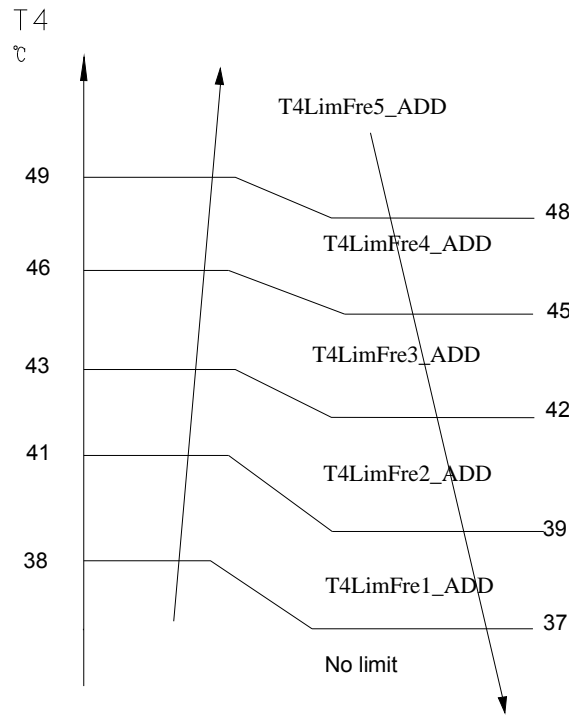

9.4.2.2 Outdoor fan running rules

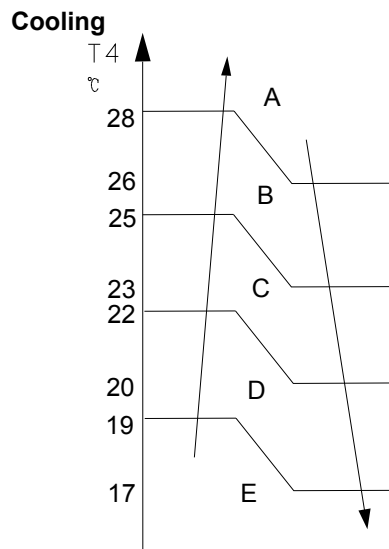

While A,B,C...means different fan speed of outdoor unit.

### 9.4.2.3 Indoor fan running rules

Indoor fan keeps running, fan speed can be set in high/mid/low/ Auto by using a remote controller:

Auto fan in cooling mode acts as follow:

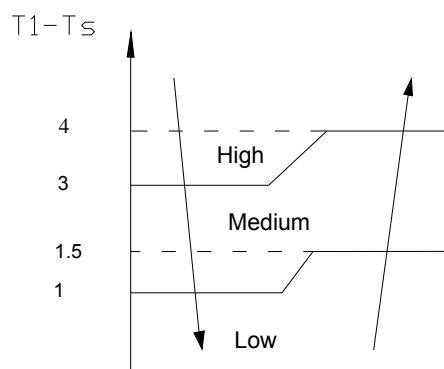

### 9.4.2.4 Evaporator low temperature T2 protection

When  $T2 < 4^\circ\text{C}$ , the indoor has no capacity demand and resume till  $T2 > 8^\circ\text{C}$

### 9.4.3 Dry mode

9.4.3.1 Indoor fan speed is fixed at breeze and can't be changed. The louver angle is the same as in cooling mode.

9.4.3.2 Low indoor room temperature protection

In drying mode, if room temperature is lower than  $10^\circ\text{C}$ , the indoor fan will stop and not resume until room temperature exceeds  $12^\circ\text{C}$ .

9.4.3.3 Evaporator anti-freezing protection and condenser high temperature protection are active and the same as that in cooling mode.

9.4.3.4 The outdoor fan operates the same as in cooling mode.

### 9.4.4 Heating mode

#### 9.4.4.1 Compressor running rules

The compressor will run at corresponding frequency according to the gross amendatory capacity demand.

Frequency	0	HEAT_F1	HEAT_F2	.....	HEAT_F15	HEAT_F16
Amendatory capacity demand.	0	1	2	.....	15	16

### 9.4.4.2 Outdoor fan running rules

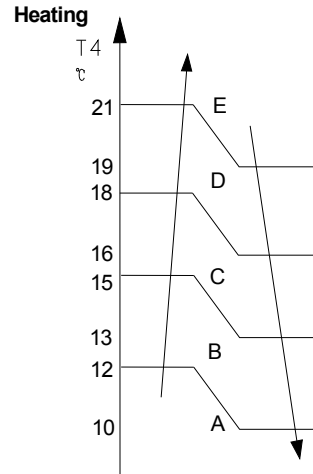

### 9.4.4.3 Indoor fan running rules

For other models:

Indoor Fan can be set at HIGH/MED/LOW/AUTO by using a remote controller, but Anti-cold wind function prevails.

Auto wind in heating mode

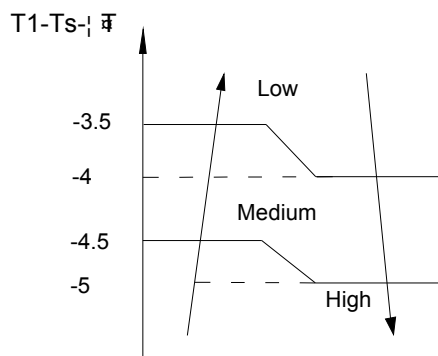

### 9.4.4.4 High evaporator coil temp.T2 protection:

If  $T_2 > 63^\circ\text{C}$ , the indoor unit has no capacity demand and resume till  $48^\circ\text{C}$ .

### 9.4.4.5 Prevent Over-Heating

In heating mode, when the indoor unit has no capacity requirement due to indoor room temperature increased, the Indoor fan will run in breeze. (Anti-cold wind function has the priority)

### 9.4.4.6 Defrosting mode:

#### Condition of defrosting:

If any one of the following items is satisfied, AC will enter the defrosting mode.

After the compressor starts up and keeps running, mark the minimum value of  $T_3$  from the 10th minutes to 15th minutes as  $T_{30}$ .

- 1) If the compressor cumulate running time is up to 29 minutes and  $T_3 < T_{CDI1}$ ,  $T_3 + T_{30} \text{SUBT}3\text{ONE} \leq T_{30}$ .
- 2) If the compressor cumulate running time is up to 35 minutes and  $T_3 < T_{CDI2}$ ,  $T_3 + T_{30} \text{SUBT}3\text{TWO} \leq T_{30}$ .
- 3) If the compressor cumulate running time is up to 40 minutes and  $T_3 < T_{CDI3}$  for 3 minutes.

4) If the compressor cumulate running time is up to 120 minutes and  $T3 < -15^{\circ}\text{C}$ .

**Condition of ending defrosting:**

If any one of the following items is satisfied, the defrosting will finish and the machine will turn to normal heating mode.

----T3 rises to be higher than  $TCDE1^{\circ}\text{C}$ .

----T3 keeps to be higher than  $TCDE2^{\circ}\text{C}$  for 80 seconds.

----The machine has run for 10 minutes in defrosting mode.

**Defrosting action:**

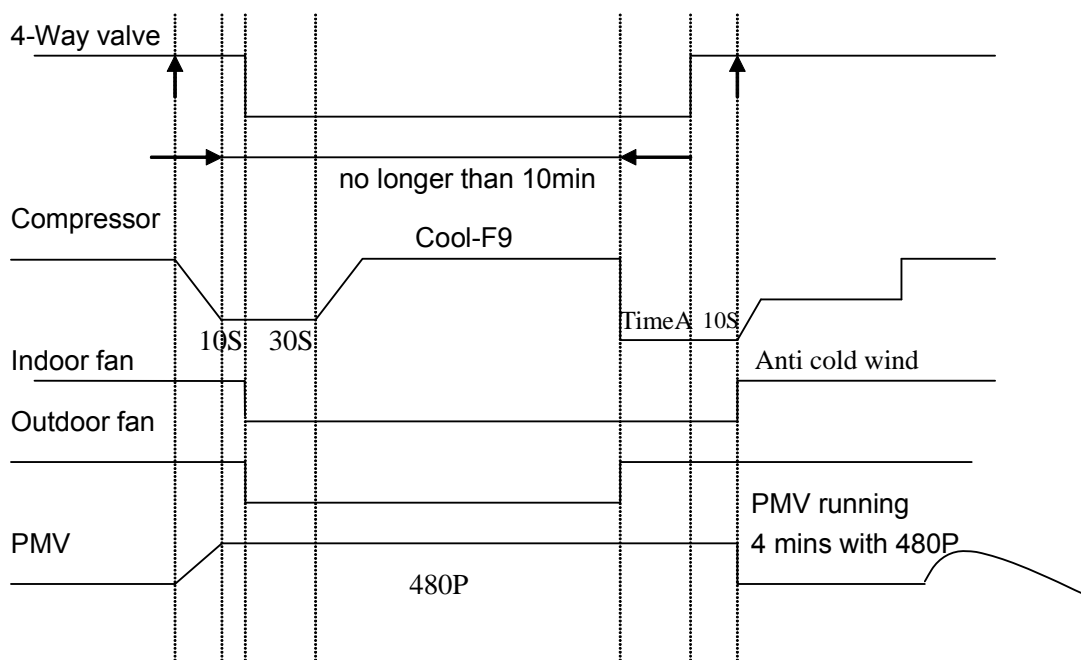

**9.4.5 Auto-mode**

This mode can be chosen by remote controller and the setting temperature can be changed between  $17\sim 30^{\circ}\text{C}$ .

In auto mode, the machine will choose cooling, heating or fan-only mode according to the difference between T1 and TS.

T1-TS	Running mode
$T1-TS > 1^{\circ}\text{C}$	Cooling
$-1 < T1-TS \leq 1^{\circ}\text{C}$	Fan-only
$T1-TS \leq -1^{\circ}\text{C}$	Heating

Indoor fan will run at auto fan of the relevant mode.

The louver operates same as in relevant mode.

If the machine switches mode between heating and cooling, the compressor will keep stopping for 15 minutes and then choose mode according to T1-Ts.

If the setting temperature is modified, the machine will choose running function again.

### 9.4.6 Forced operation function

#### 9.4.6.1 Enter forced operation function:

Press the touch button continually, the AC will run as below sequence:

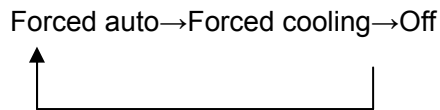

When the machine is off, pressing the touch button will carry the machine to forced auto mode, after this, if pressing the button once again, the machine will turn into forced cooling mode.

In forced cooling mode, pressing touch button will turn off the machine.

#### 9.4.6.2 In forced operation mode, all general protections and remote control are available.

#### 9.4.6.3 Operation rules:

##### Forced cooling mode:

The compressor runs at F2 frequency and indoor fan runs as breeze. After running for 30 minutes. the machine will turn to auto mode as 24°C setting temperature.

##### Forced auto mode:

The action of forced auto mode is the same as normal auto mode with 24□ setting temperature.

9.4.6.4 When there's indoor unit running in forced cooling, it is the master forced cooling unit. Other indoor units will run at forced cooling mode too and they will be the slave forced cooling units. The slave forced cooling units can not quit forced cooling mode until the master forced cooling unit quit, and turn to cooling mode at low speed with 24□ setting temperature.

9.4.6.5 The slave forced cooling units will not be controlled by other signals.

### 9.4.7 Timer Function

9.4.7.1 Timing range is 24 hours.

9.4.7.2 Timer on. The machine will turn on automatically when reaching the setting time.

9.4.7.3 Timer off. The machine will turn off automatically when reaching the setting time.

9.4.7.4 Timer on/off. The machine will turn on automatically when reaching the setting "on" time, and then turn off automatically when reaching the setting "off" time.

9.4.7.5 Timer off/on. The machine will turn off automatically when reaching the setting "off" time, and then turn on automatically when reaching the setting "on" time.

9.4.7.6 The timer function will not change the AC current operation mode. Suppose AC is off now, it will not start up firstly after setting the "timer off" function. And when reaching the setting time, the timer LED will be off and the AC running mode has not been changed.

9.4.7.7 The setting time is relative time.

### 9.4.8 Sleep mode

9.4.8.1 The sleep function is available in cooling, heating or auto mode.

9.4.8.2. Operation process in sleep mode is as follow.

After pressing ECONOMIC or SLEEP button on controller, the machine will turn into sleep mode.

When cooling, The set temperature rise 1°C per hour (be lower than 30□). Two hours later, the set temperature will maintain as a constant and the fan speed is kept at low speed.

When heating, The set temperature decrease 1°C per hour (be higher than 17□). Two hours later, the set temperature will maintain as a constant and the fan speed is kept at low speed (Anti-cold function takes precedence over all).

When auto, After an hour running under economic mode, if it is under cooling mode the set temp will rise 1°C, if it is under heating mode the set temp will decrease 1°C, if it is under fan-only mode the set temp will be changeless; the condition will be the same after the air conditioner running under economic mode after 2 hours, and during the next time the set temp do not change.

9.4.8.3 Operation time in sleep mode is 7 hours. After 7 hours the AC quits this mode and the AC will turn off.

9.4.8.4 Timer off and remote controller off signals have the priority compared with sleep function.

#### **9.4.9 Auto-Restart function**

The indoor unit is equipped with auto-restart function, which is carried out through an auto-restart module. In case of a sudden power failure, the module memorizes the setting conditions before the power failure. The unit will resume the previous operation setting (not including swing function) automatically after 3 minutes when power returns.

If the memorization condition is forced cooling mode, the unit will run in cooling mode for 30 minutes and turn to auto mode as 24°C setting temp.

If AC is off before power off and AC is required to start up now, the compressor will have 1 minute delay when power on. Other conditions, the compressor will have 3 minutes delay when restarts.

#### **9.4.10 Drain pump control**

Adopt the water-level switch to control the action of drain pump.

Main action under different condition : ( every 5 seconds the system will check the water level one time)

1. When the A/C operates with cooling (including auto cooling) and forced cooling mode or dry mode, the pump will start running immediately and continuously, till stop cooling or dry or no capacity demand.
2. Once the water level increase and up to the control point, LED will alarm and the drain pump open and continue checking the water level. If the water level falls down below the control point (drain pump delay close 1 minute) and operate with the last mode. Otherwise the entire system stop operating (including the pump) and LED remain alarming after 3 minutes,

#### **9.4.11 Follow me (optional)**

- 1) If the indoor PCB receives the signal which results from pressing the FOLLOW ME button on remote controller, the buzzer will emit a sound and this indicates the follow me function is initiated. But when the indoor PCB receives signal which sent from remote controller every 3 minutes, the buzzer will not respond. When the unit is running with follow-me function, the PCB will control the unit according to the

temperature from follow-me signal, and the temperature collection function of room temperature sensor will be shielded, and the error detective function of room temperature sensor will be still invalid.

- 2) When the follow-me function is available, the PCB will not respond according to the setting temperature from follow-me signal every 3 minutes.
- 3) The PCB will take action to the mode change information from remote controller signal, and the follow-me function will be turned off. (if the wired remote controller does not initiate follow me function).
- 4) When the unit is running with follow-me function, if the PCB doesn't receive any signal from remote controller for 7 minutes or pressing FOLLOW ME button again, the follow-me function will be turned off automatically, and the temperature collection function of room temperature sensor will be available, the PCB will control the unit according to the room temperature detected from its own room temperature sensor and setting temperature.
- 5) When the indoor PCB receives the follow-me signal from wired remote controller, the control is the same as that from wireless remote controller, but buzzer will not emit a sound. When the PCB receives turning-off follow-me signal from wired remote controller, the unit will quit follow-me function at once. The follow-me function controlled by wired remote controller prevails that by wireless remote controller.

#### 9.4.12 Mode conflict

The indoor units can not work cooling mode and heating at same time.

Heating mode has a priority.

##### (1) Definition

	Cooling mode	Heating Mode	Fan	Off
Cooling mode	No	Yes	No	No
Heating Mode	Yes	No	Yes	No
Fan	No	Yes	No	No
Off	No	No	No	No

No: No mode conflict;

Yes: Mode conflict

##### (2) Unit action

- In case of one Indoor unit working in cooling mode or fan mode, and another indoor unit is set to heating mode, the indoor unit working in cooling mode or fan mode will change to off. The outdoor unit will change to heating mode after compressor stop 3 minutes. .
- In case of one Indoor unit working in heating mode, and another indoor unit is set to cooling mode or fan mode, the indoor unit setting to cooling mode or fan mode will change to stand by. The outdoor unit will continue working in heating mode.

If heating mode stops (not including the indoor unit in heating mode reaching the set temperature), 3 minutes after the outdoor unit restarts and works in cooling mode or fan-only mode.