

Content

1. GENERAL INFORMATION	
1.1 MODEL NAMES OF BASE STATION AIR CONDITIONER	
1.2 EXTERNAL APPEARANCE	
1.3 NOMENCLATURE	
3. COMPACT TYPE BASE STATION AIR CONDITIONER.....	
3.1 FEATURES	
3.2 REFRIGERANT CIRCUIT	
3.3 UNIT STRUCTURE.....	
3.4 SPECIFICATIONS	
3.5 DIMENSION	
3.6 INDOOR UNIT CAPACITY CURVE	
3.7 WIRING DIAGRAM.....	
3.8 INSTALLATION	
3.9 FIELD WIRING	
3.10 TRIAL RUN.....	
3.11 MAINTENANCE	
3.12 TROUBLE SHOOTING	
3.13 FUNCTION.....	
3.14 OPERATION.....	
3.15 ACCESSORIES	

1. General information

Midea Base Station Air Conditioners are designed for installation in telecommunications containers and equipment rooms. Those sites are usually in the country side, on the top of mountains, maybe miles of nowhere from cities. As the compressors are equipped at indoor units, units are protected against environmental influences and vandalism. All units are designed for running 24 hours a day and 365 days a year. There are two types of unit structures: split type and compact type, the cooling capacity range is from 5.5kW to 13kW.

1.1 Model names of base station air conditioner

Type		Model	Power Supply	Remarks
Compact type		KCD-60L/S-JZ(E1)	380V~, 50Hz,3Ph	With free cooling function
		KCD-75L/S-JZ(E2)	380V~, 50Hz,3Ph	
		KCD-120L/S-JZ	380V~, 50Hz,3Ph	

Model names of base station air conditioner CE approved

Type		Model	Power Supply	Remarks
Compact type		MRT-60HN2	380V~, 50Hz,3Ph	With free cooling function
		MRT-75HN2	380V~, 50Hz,3Ph	
		MRT-120HN2	380V~, 50Hz,3Ph	

1.2 External appearance



Compact type

3. Compact Type Base Station Air Conditioner

3.1 Features

- ✧ Compact designed, the whole air conditioner system is protected by room, making it much stable and longer working life.
- ✧ The unit designed for large air flow volume, can take the heat load out from base station rapidly and effectively.
- ✧ Power phase sequence fault tolerance function. If the zero line is properly connected, the controller will automatically adjust the wiring to make sure the power wiring is working properly.
- ✧ Operating range from -40°C to 45°C outside temperature.
- ✧ At low outside temperature, cooling directly with outside air, to save energy.
- ✧ Fresh air inlet is equipped with dual filter to prevent equipment in station from dust damage.
- ✧ Auto restart after power failure, unit will restart with the previous operation and setting automatically when the power resumes.
- ✧ An air-conditioning system can be configured maximum 2 units by the controller. If an individual unit drops out or the heat load rises, inactive standby units are switched in for support.
- ✧ The operating times of all connected units are compared to ensure that each on is used to an equal extent.
- ✧ Serial interface RS485 for connection to the internet to remote monitoring and control.

3.2 Refrigerant circuit

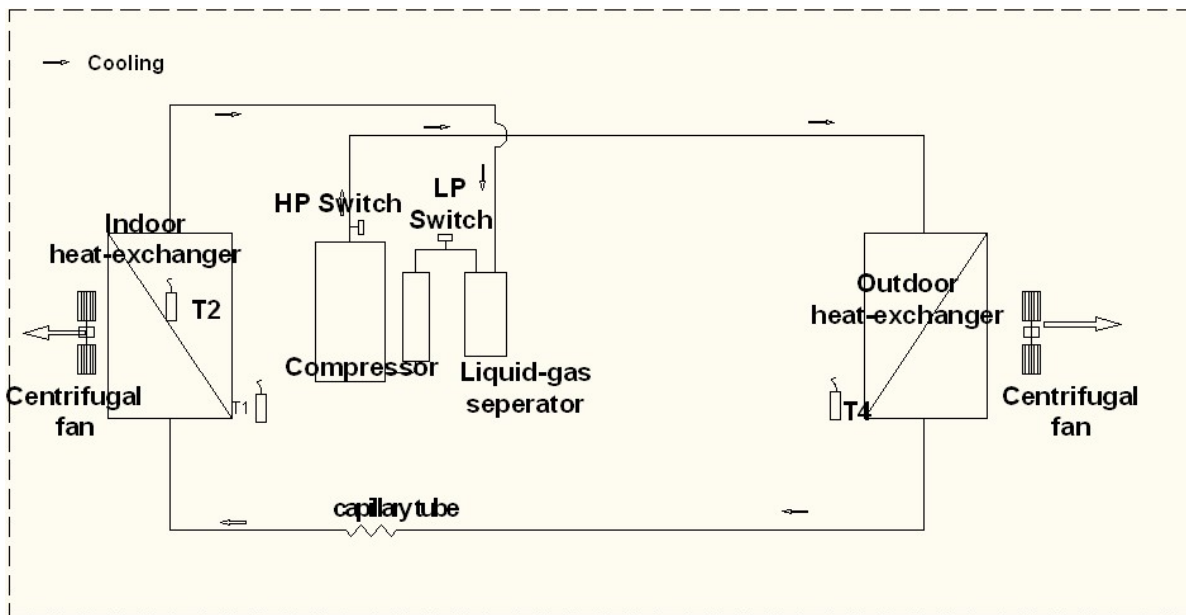

Compressor: KCD-60L/S-JZ(E1), MRT-60HN2 is equipped with rotary compressor.

KCD-75L/S-JZ(E2), KCD-120L/S-JZ, MRT-75HN2, MRT-120HN2

are equipped with scroll compressor.

Condenser and Evaporator: Copper tube and Aluminum fin type heat exchanger.

Capillary: Capillary subassembly.

Fan: Centrifugal fan

3.3 Unit structure

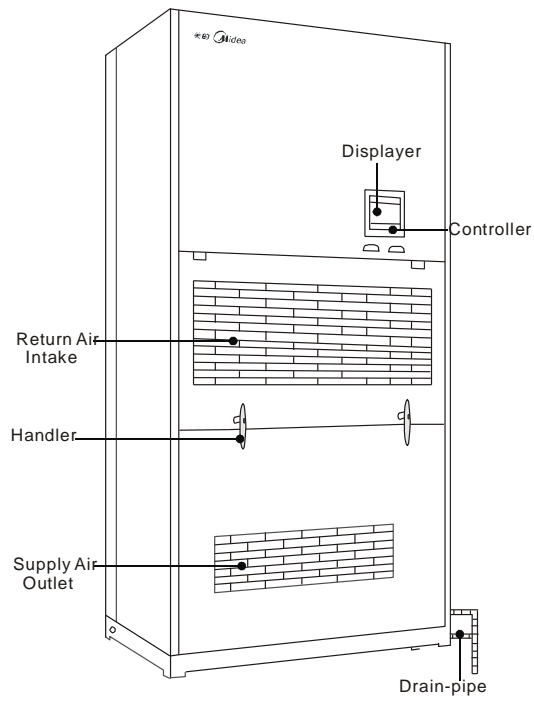

Air distribution

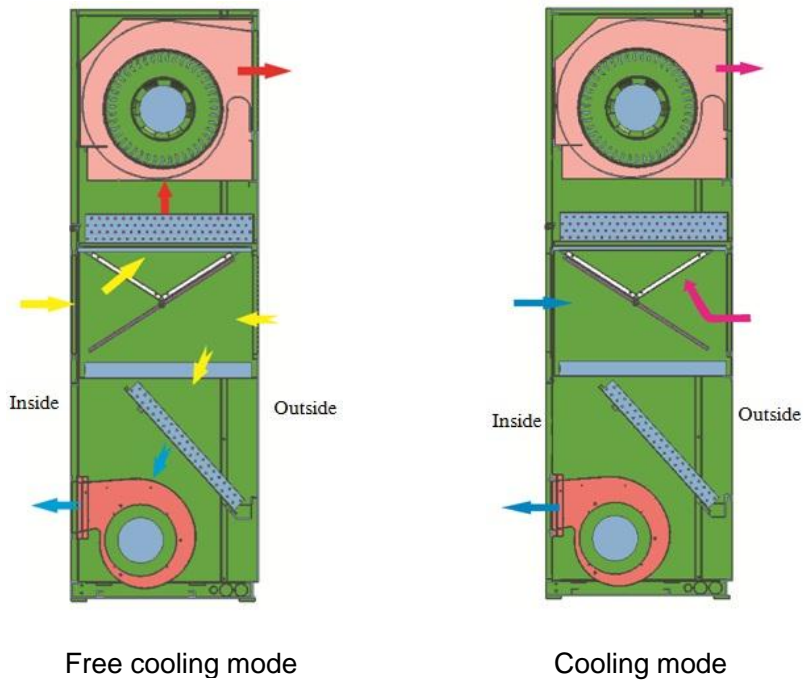

3.4 Specifications

Market model CE			MRT-60HN2	MRT-75HN2	MRT-120HN2
Market model			KCD-60L/S-JZ(E1)	KCD-75L/S-JZ(E2)	KCD-120L/S-JZ
Power input	V-Ph-Hz		380V~ 3Ph 50Hz	380V~ 3Ph 50Hz	380V~ 3Ph 50Hz
Cooling	Total capacity	W	6000	7500	12000
	Sensible capacity	W	5700	6600	9120
	Cooling input	W	1824	2580	4280
	EER		3.29	2.90	2.80
Heating Capacity		W	3350	3500	3510
Max. power input		W	3450	3600	5900
Max. current		A	15.0	8.2	15.2
Refrigerant	Type		R407C		
	Charge	kg	2.8	3.25	4.08
Throttle device			Capillary	Capillary	Capillary
Air supply directions			Down front supply	Down front supply	Down front supply
Evaporator/Condenser			Copper tube and Aluminum fin	Copper tube and Aluminum fin	Copper tube and Aluminum fin
Compressor	Type		Rotary	Scroll	Scroll
	Model		SH307RV-C8LU	VR30KS-TFP-582	VR52KS-TFP-542
	Brand		Hitachi	Copeland	Copeland
	Capacity	Btu/h	17265	25000	43700
	Input	W	1650	2230	3770
	Rated current	A	7.75	4.1	6.8
	Locked rotor amp	A	41	34	59
Up motor	Model		YDK120-8H	YDK120-8G	YDK120-8J
	Input (xNo.)	W	149 (x2)	203 (x2)	275 (x3)
	Speed	rpm	445	575	650
Down motor	Model		YSK90-6H	YSK90-6F	YSK250-4E
	Input (x No.)	W	148 (x1)	156 (x1)	430 (x1)
	Speed	rpm	775	865	1080
Free cooling function			Yes	Yes	Yes
Air flow rate		m ³ /h	1550	1700	2300
Drainage pipe OD		mm	16.5	16.5	16.5
Weight (Net / Gross)		kg	205/220	205/220	270/285
Dimension	Body (WxHxD)	mm	1000x1900x600	1000x1900x600	1250x1900x600
	Packing (WxHxD)	mm	1025x1930x675	1025x1930x675	1280x1930x675
Ambient temperature range		°C	-40~+45	-40~+45	-40~+45

Notes:

Cooling conditions: Indoor air 28°C DB/ 20°C WB, Outdoor air 35°C DB/ 26°C WB.

The sound pressure level refers to a distance of 1m from the outer surface of the unit.

3.5 Dimension

KCD-60L/S-JZ(E1) / KCD-75L/S-JZ(E2)

MRT-60HN2/MRT-75HN2

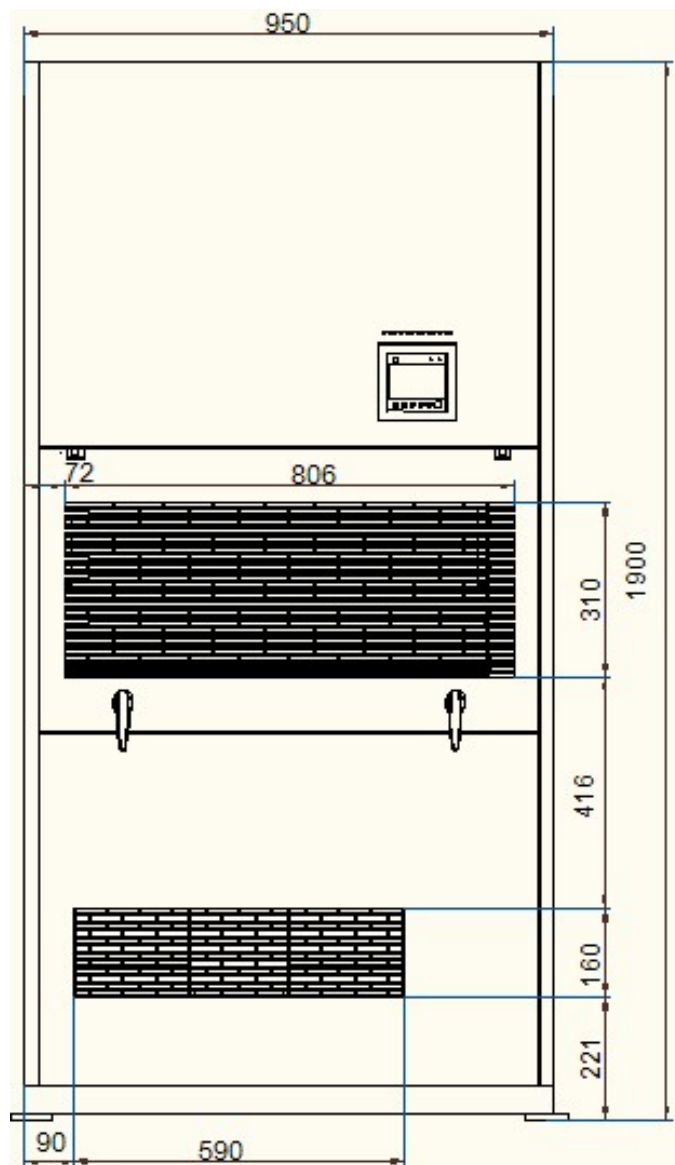
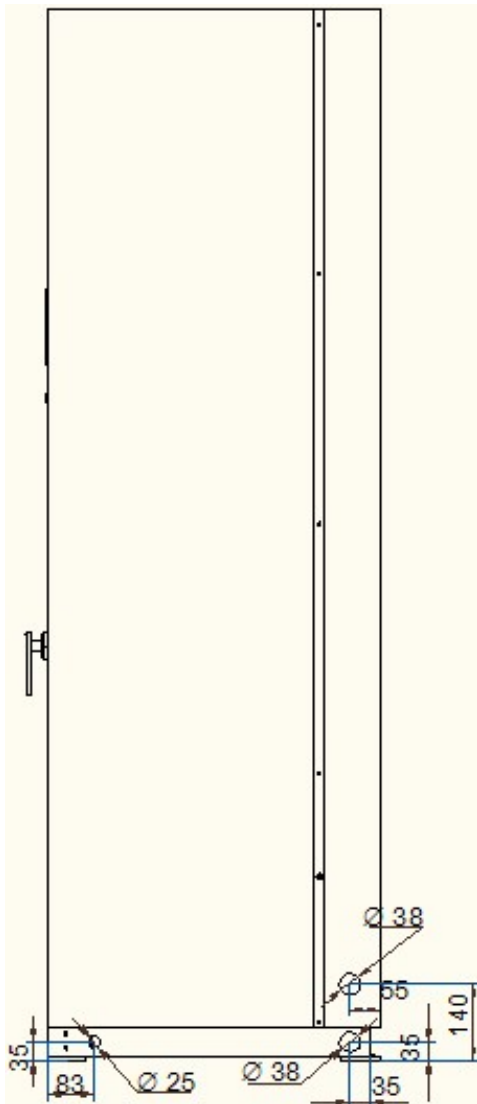
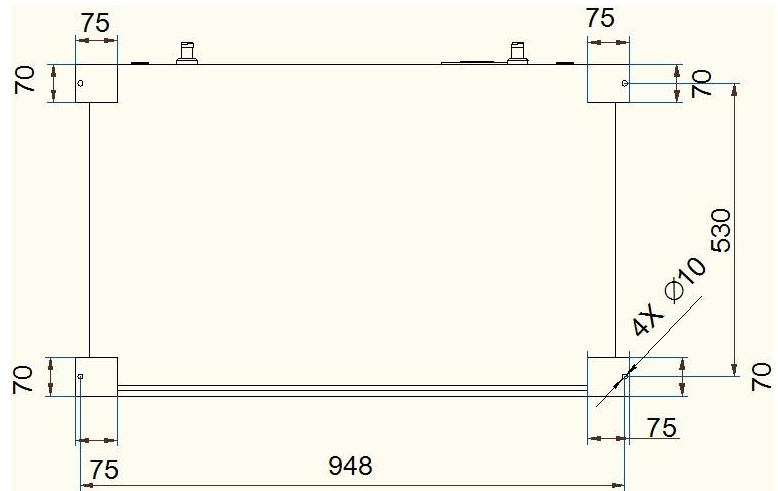

KCD-120L/S-JZ
MRT-60HN2

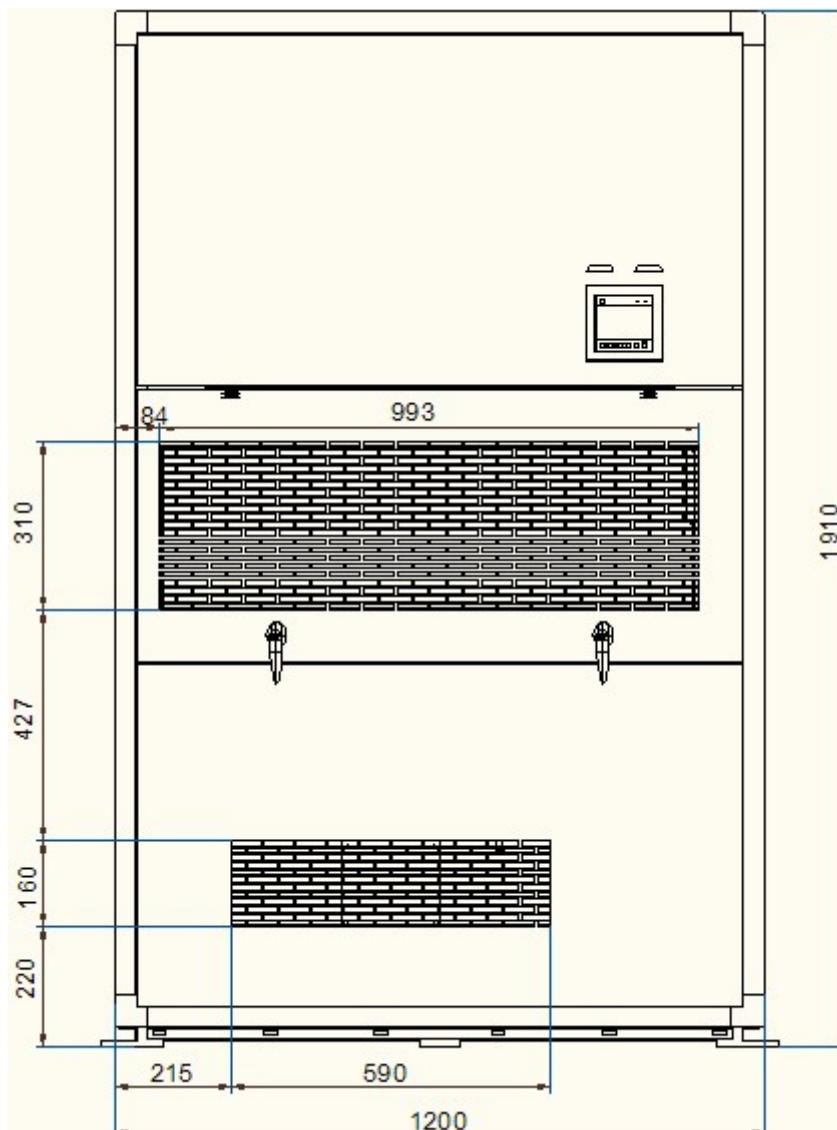
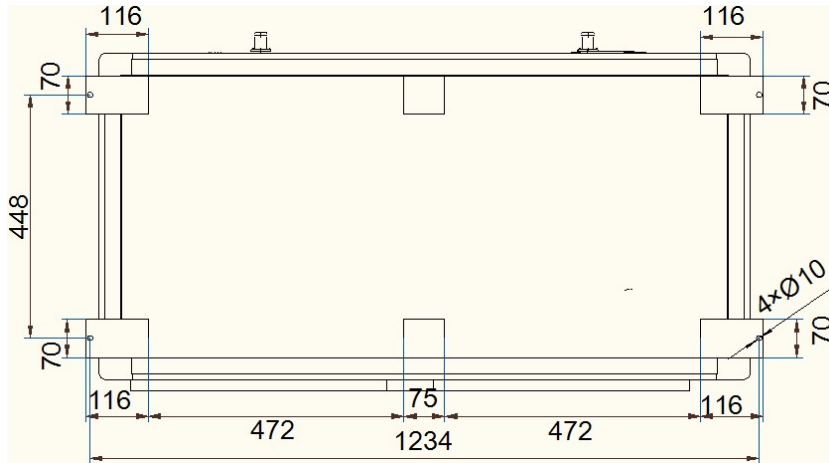

3.6 Indoor unit capacity curve

KCD-60L/S-JZ(E1)

MRT-60HN2

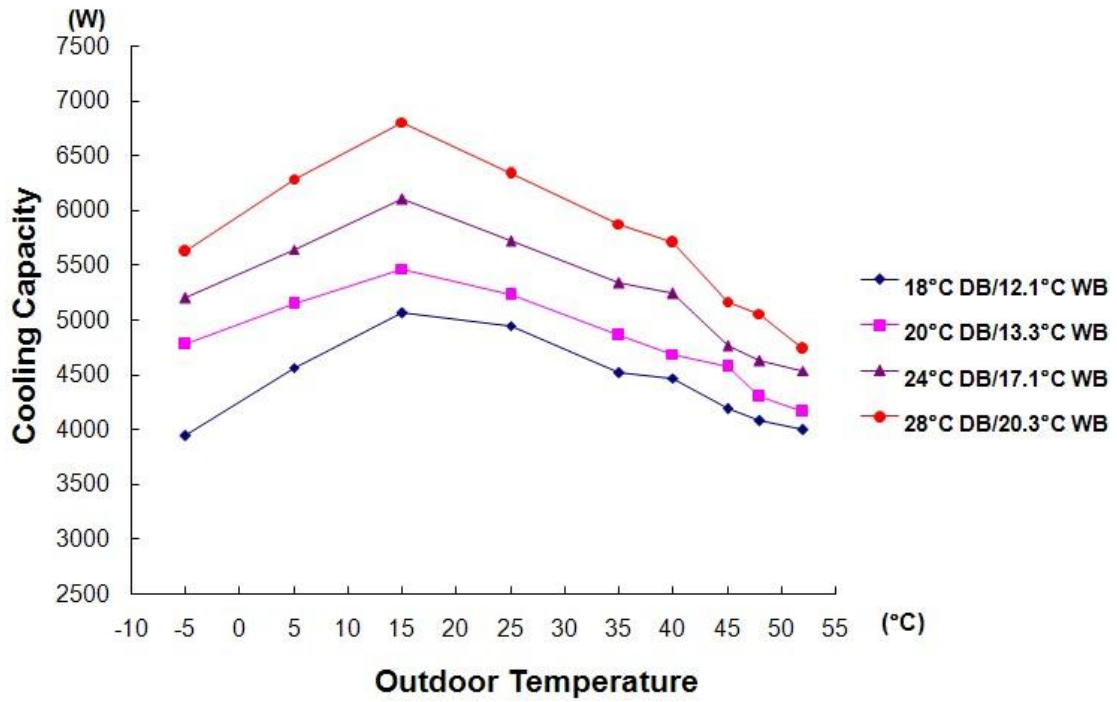

KCD-75L/S-JZ(E2)

MRT-75HN2

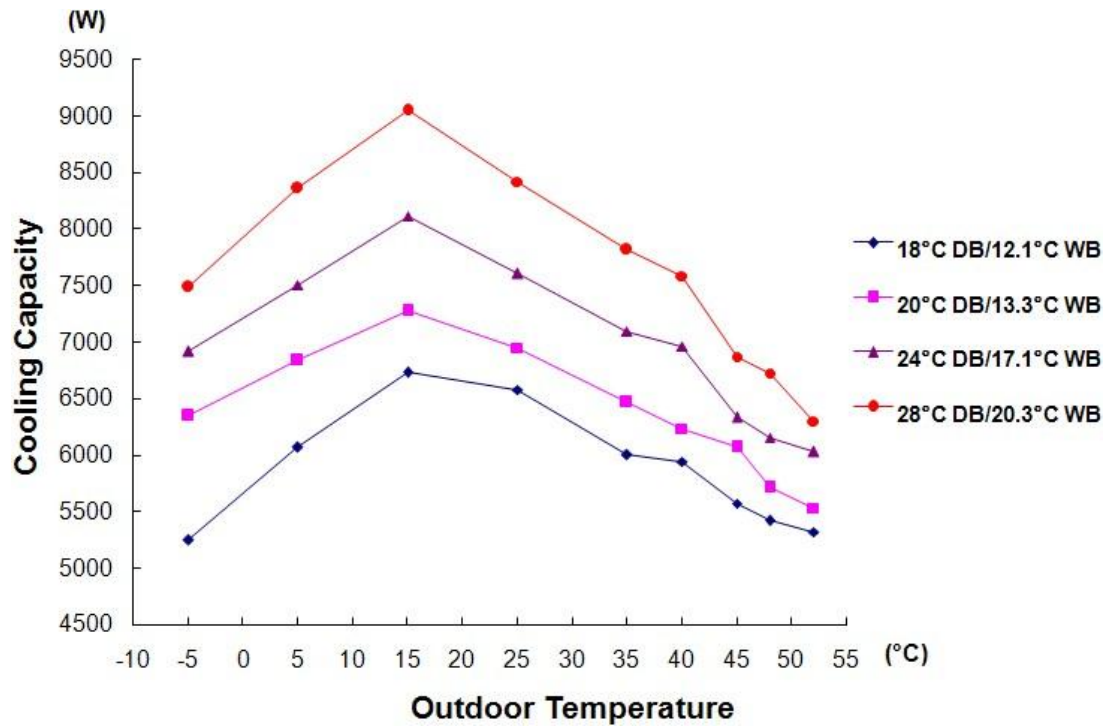

KCD-120L/S-JZ

MRT-120HN2

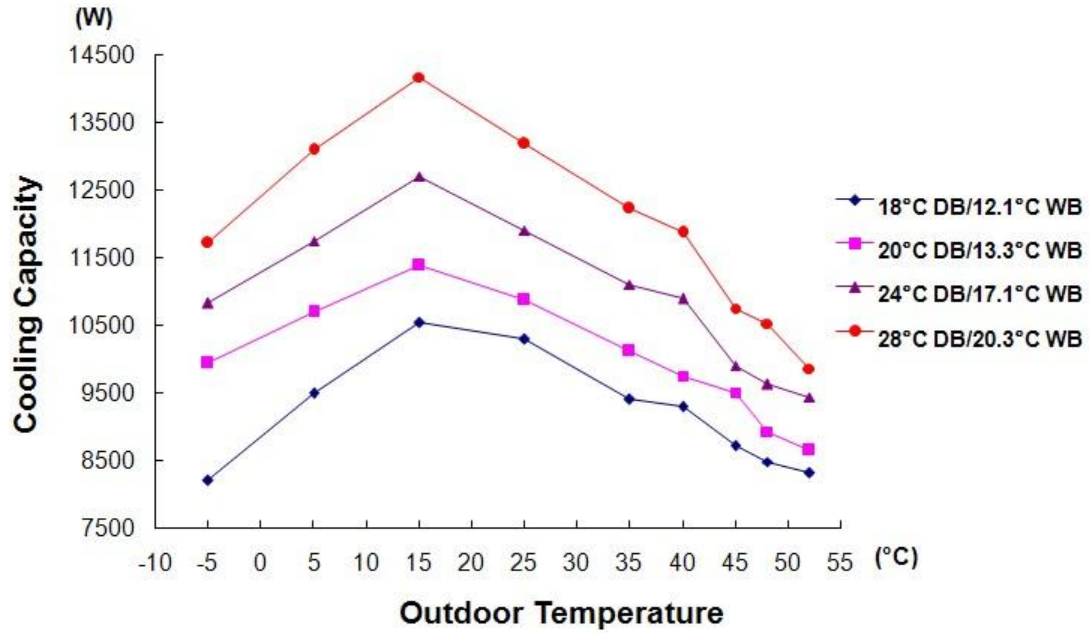

3.7 Wiring diagram

KCD-60L/S-JZ(E1)

MRT-60HN2

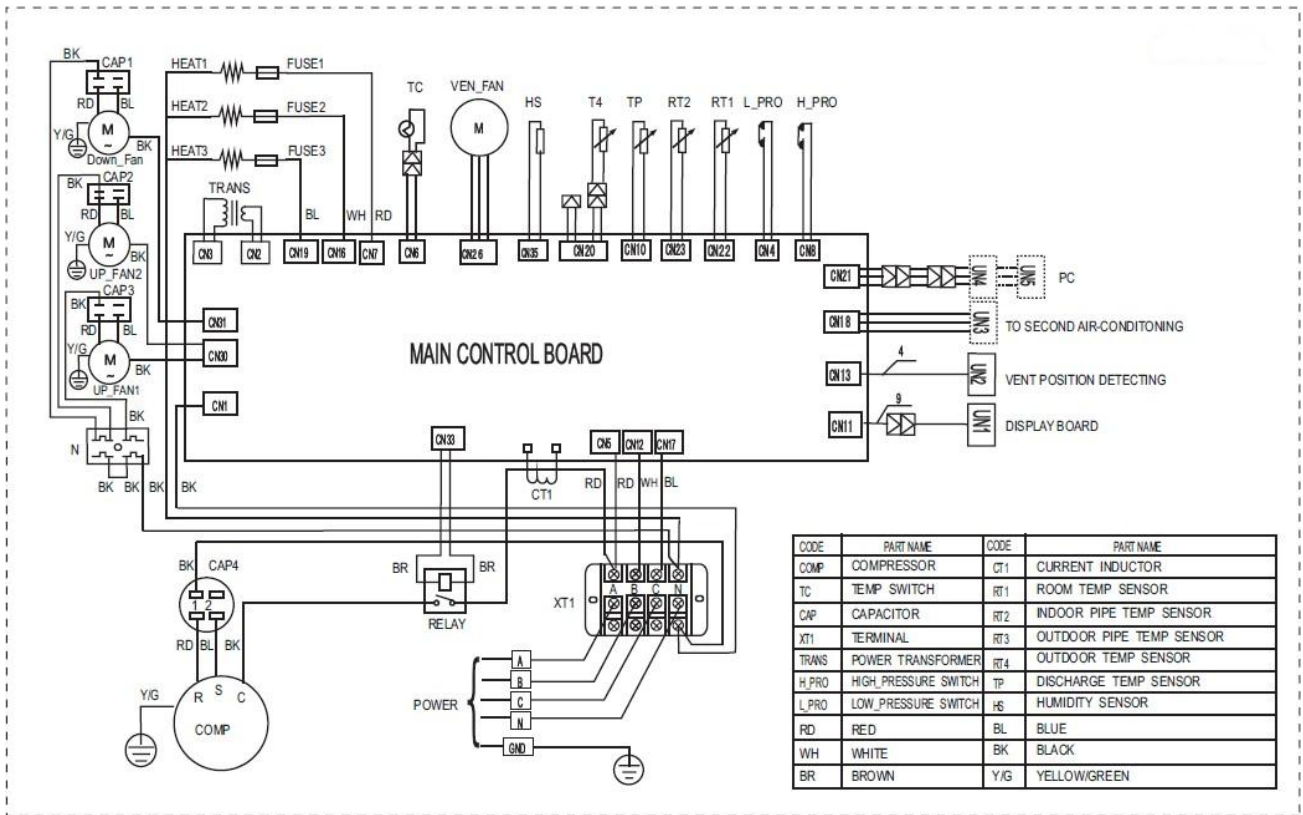

KCD-75L/S-JZ(E)

MRT-75HN2

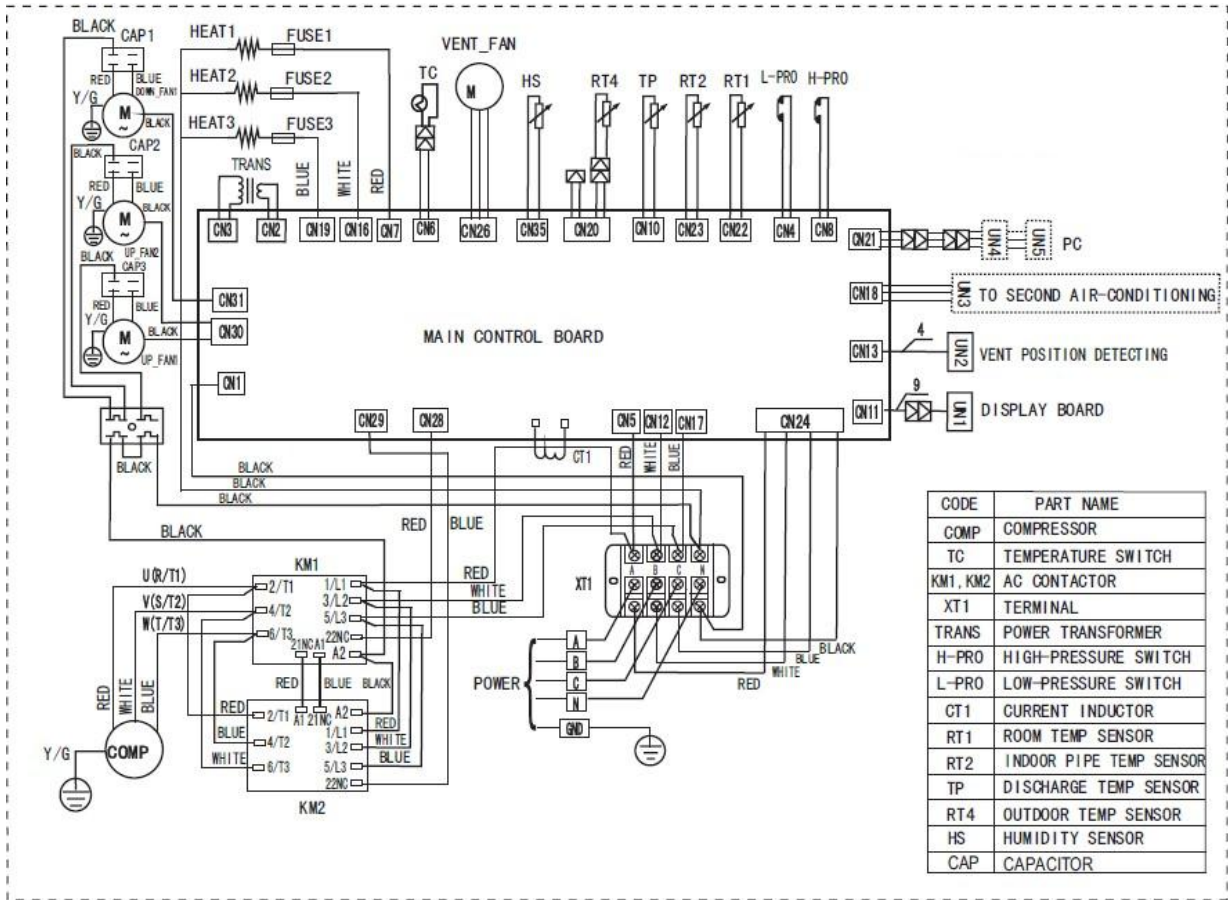

KCD-120L/S-JZ

MRT-120HN2

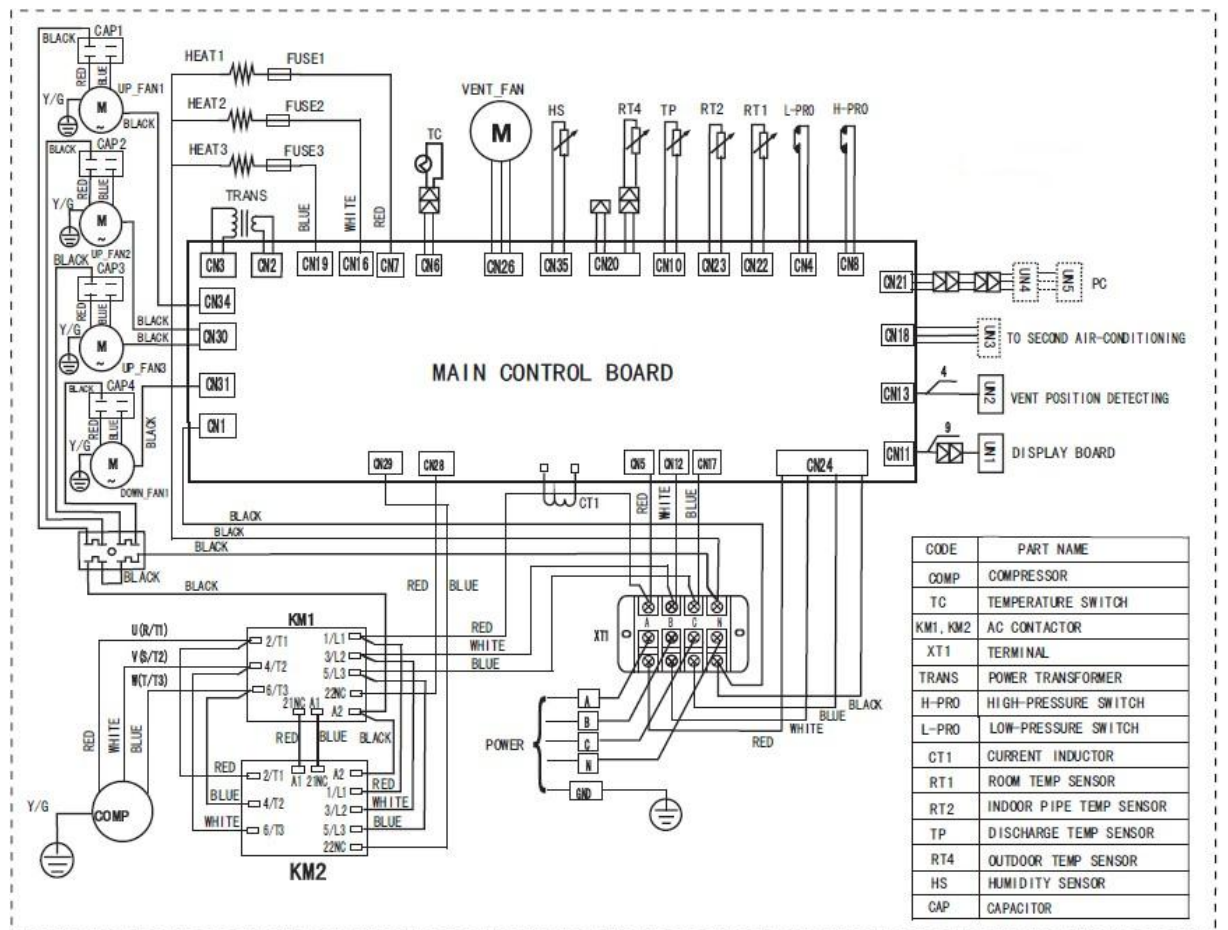

3.8 Installation

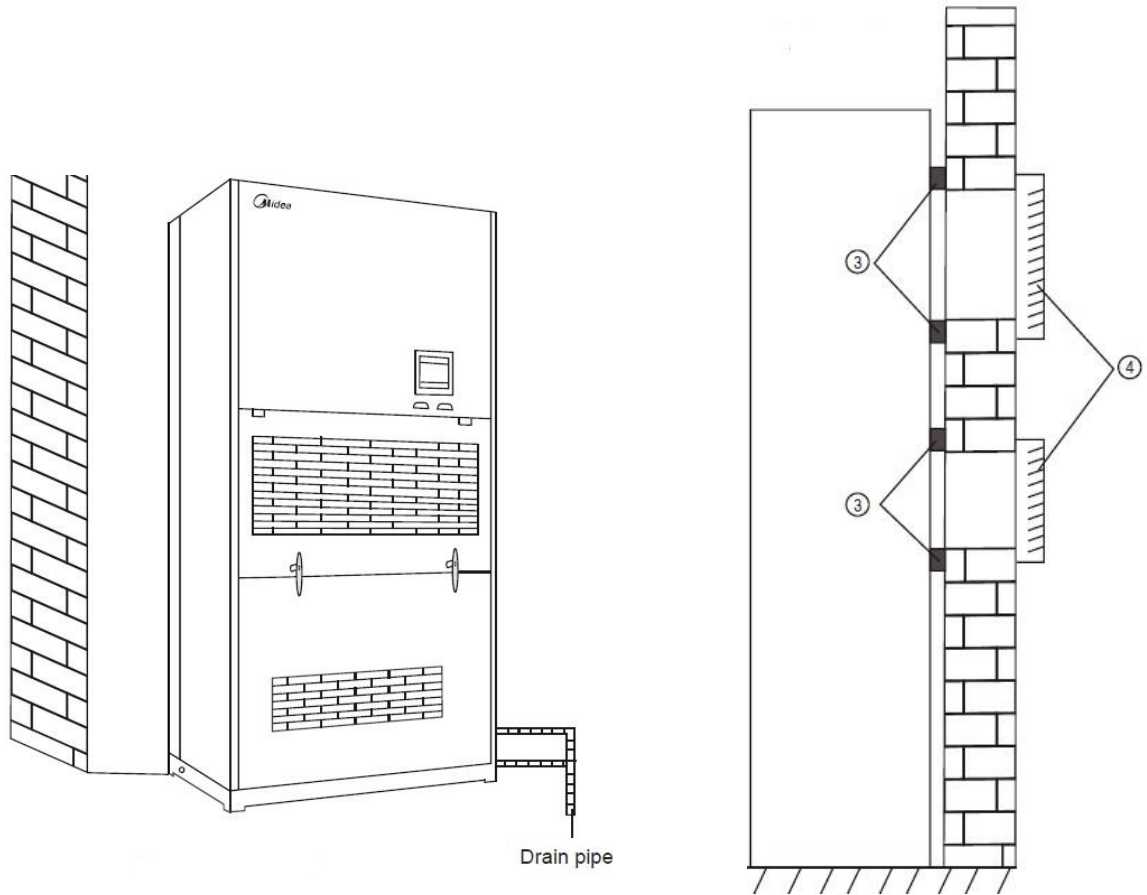

Dorsal view: KCD-60L/S-JZ(E1), KCD-75L/S-JZ(E2)

MRT-60HN2

MRT-75HN2

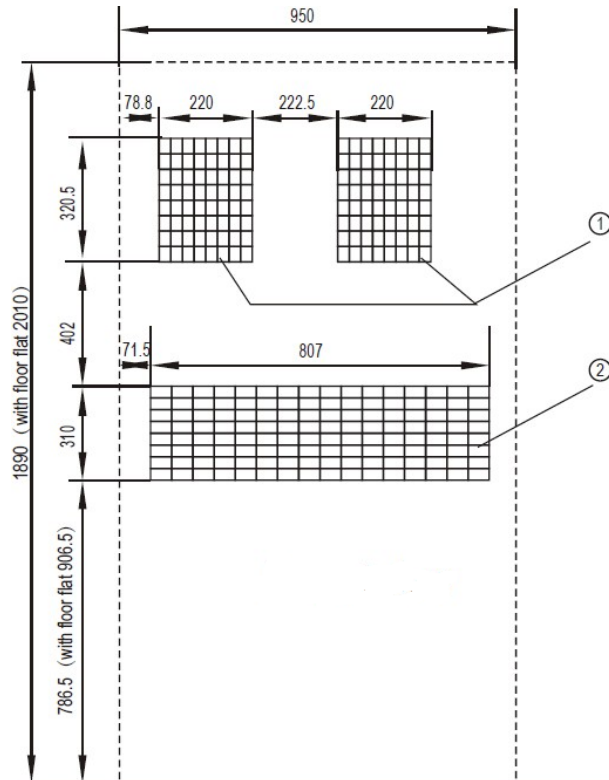

Dorsal view: KCD-120L/S-JZ

MRT-120HN2

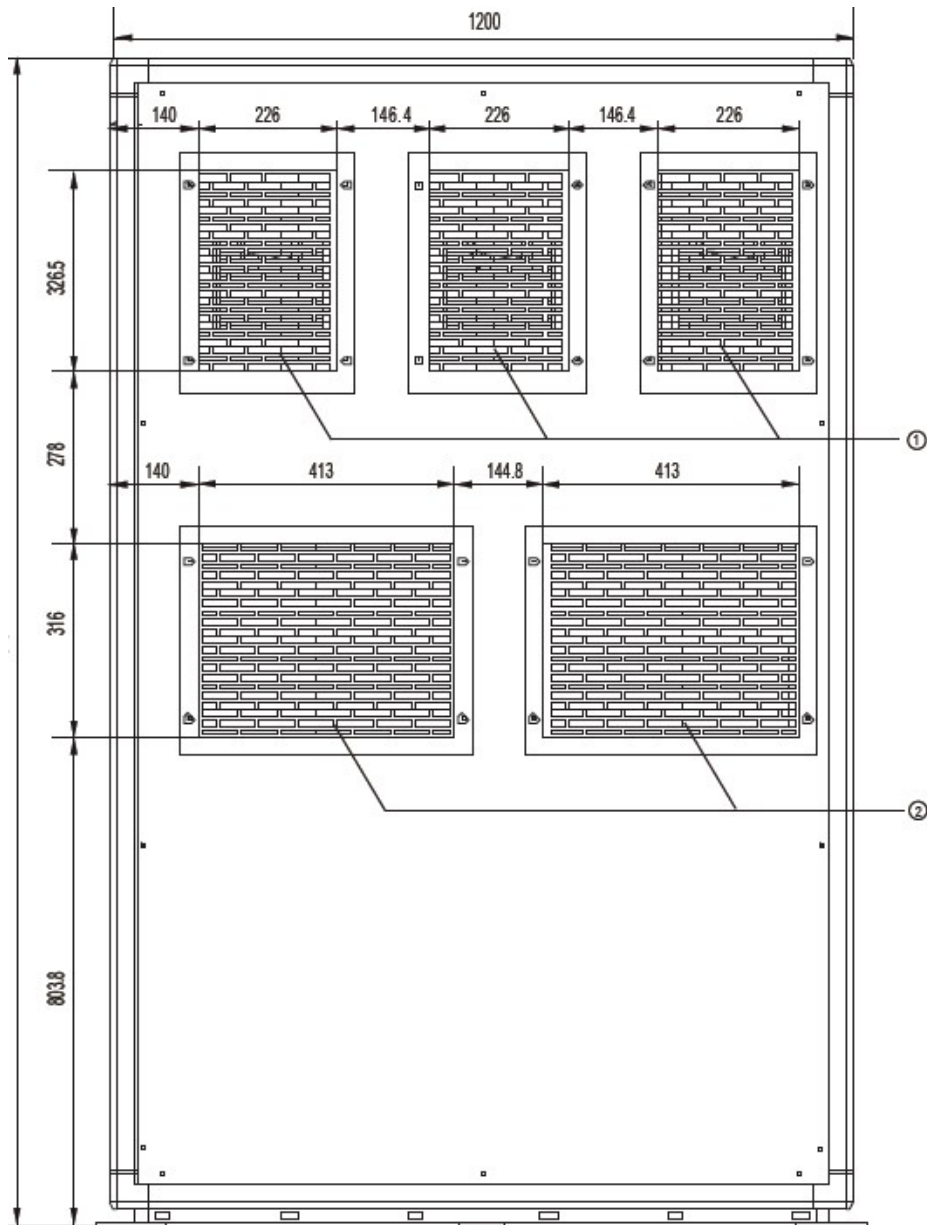

Notes:

- Outdoor side air outlet
- Fresh air inlet
- Sealing gaskets
- Burglar mesh (User provides)

Location

- ✧ Units should be installed away from the heat source and vapor source.
- ✧ There is no any obstruction to block the air circulation.
- ✧ The location should be able to support the unit weight, and will not increase the running noise and vibration.
- ✧ The location should be convenient to do the unit piping, wiring and draining condensing water.

Water drainage

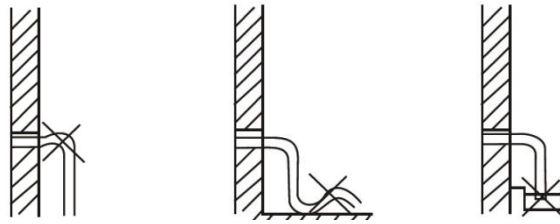

- ✧ When lengthening the drain pipe, please must do heat insulation for the flexible pipe lengthened part of the indoor side.
- ✧ Do not make the lengthened drain pipe loose.
- ✧ No draining barriers in piping the drain pipes.
- ✧ When the drain pipes connect to the outdoor, it should be wrapped around with heat insulation material, and rolled on the surface by packing belts to avoid air come in and cause condensation.
- ✧ Laying the dram pipe should be downward slopping, do not make rising drainage.
- ✧ Do not place the end of the drain pipe in the water.

3.9 Field wiring

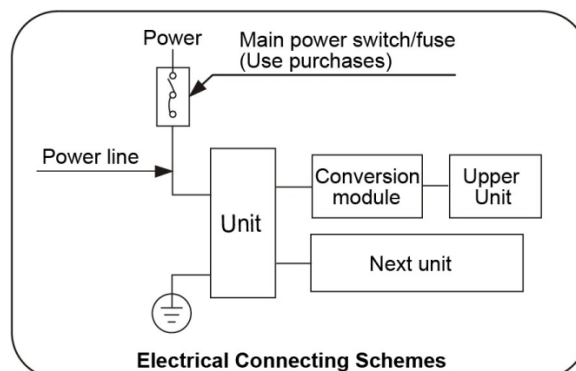

- ✧ The maximum allowed voltage fluctuation is $\pm 10\%$.
- ✧ Be sure unit is correctly earthing.
- ✧ Be sure equipped electric leakage switch, main switch and fuse. The capacity of fuse should be calculated as followed: the max. ampacity= $(1.5\sim 3) \times$ the max. current of air conditioner + total current of other electrical equipment. Cable introduction:

Air conditioner line			Main power line		
Max. current (A)	Wire cross-section area (mm ²)	Switch/ fuse capacity (A)	Max. current (A)	Wire cross-section area (mm ²)	Switch/ fuse capacity (A)
≤10	1 or 1.5	16/16	≤16	1.5~4	32/25
≤16	1.5 or 2.5	32/25	≤25	2.5~4	63/50
≤25	2.5 or 4	63/50	≤32	4~10	63/50
≤32	4 or 6	63/50	≤40	6~16	100/80
			≤63	10~25	125/125

3.10 Trial run

- ✧ After all the electric safety check and leakage check, it must power on to trial run the unit, the operation time should not less than 30 minutes.
- ✧ After power on, press the 'Trial run' buttons in the control panel, then enter into the trial run state.
- ✧ Trial run test item:

Value judging type	Intuition judging type	Observation type
*Value display *Temperature setting *Air outlet temperature *Air inlet temperature *Room temperature change	*Protect switch action *Abnormal noise *Vibration situation *Wind board swinging situation	*Air return temperature difference *Room temperature difference *Whether the liquid in the evaporator flows and frosts.

- ✧ After 30 minutes, the unit will automatically stop the trial run.
- ✧ In the trial run state, press the 'Trial run' button, or press the 'ON/OFF' button, then can stop the trial run.

3.11 Maintenance

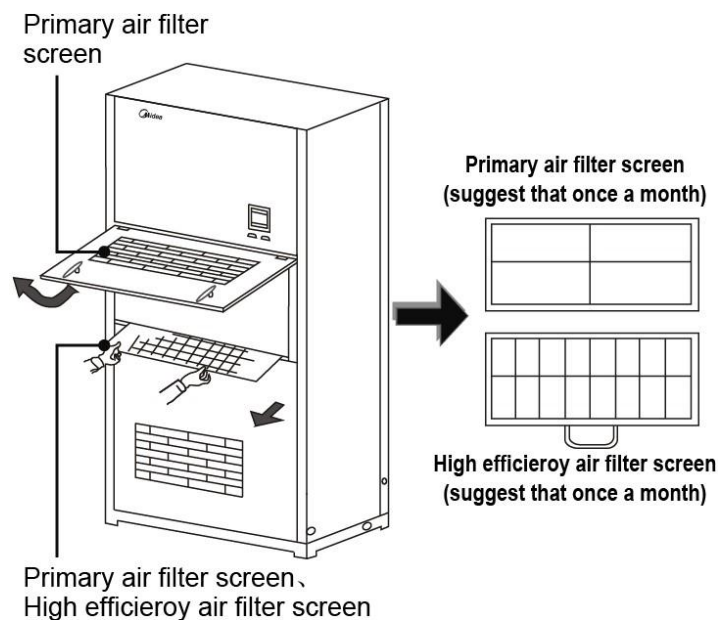

Clean

- ✧ Clean the unit shell, air outlet positions and grille with a piece of clean dry cloth. Neutral detergent solution can be used.
- ✧ Clean the air filters at least once a month (it is recommended once in two week). Remove the filters, wash, dry in shady place, and then reinstall them.

Notice: Be sure cut off the power before cleaning.

Idle for a long time

If unit will not use for a long time, the following measurement should be taken:

- ✧ Clean the unit shell and air filter.

- ✧ Cut off the power, and turn off the breaker.
- ✧ Check and clean the inside of unit regularly, this should be taken by the professional.

After idle for a long time

- ✧ Check whether the air inlet and outlet positions are clean, if blocked, clean it out.
- ✧ Check whether the earthing wire is in good condition and correct connected.
- ✧ Clean the unit shell and air filter.
- ✧ Check and make sure the drain-pipe can drain smoothly.
- ✧ Turn on the switch.

3.12 Trouble shooting

Phenomenon	Reason	Solution method
The air conditioner cannot operate.	Power off	Wait for the power recovery
	Do not connect to the power switch.	Connect to the power switch.
	The power switch fuse has been broken.	Change the fuse.
There has air come out, but the cooling/heating effect is not good.	The temperature setting is not suitable.	Properly set the temperature.
	The air filter has been blocked by dust.	Clean the filter.
	The baffle is opened.	Close the baffle.
	The air inlet or outlet has been blocked.	Clean out the blocks
	Compressor 3 minutes protection	Wait for a while.

Malfunction and protection codes

Malfunction code	Content
E1	Return air of indoor side temperature sensor (T1) failure.
E2	Evaporator temperature sensor (T2) failure.
E4	Return air of outdoor side temperature sensor (T4) failure.
E6	Lack of the unit phase.
E8	Humidity sensor failure.
P1	High pressure protection of compressor
P2	Low pressure protection of compressor
P3	High discharge temperature protection, compressor shutdown.
P4	Low temperature protection of evaporator, compressor shutdown.

E1, E2, E4

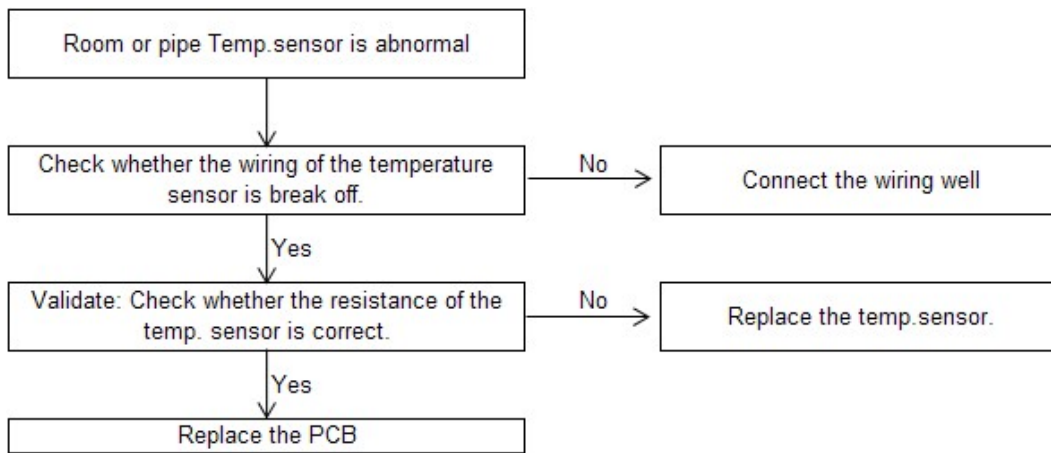

E6

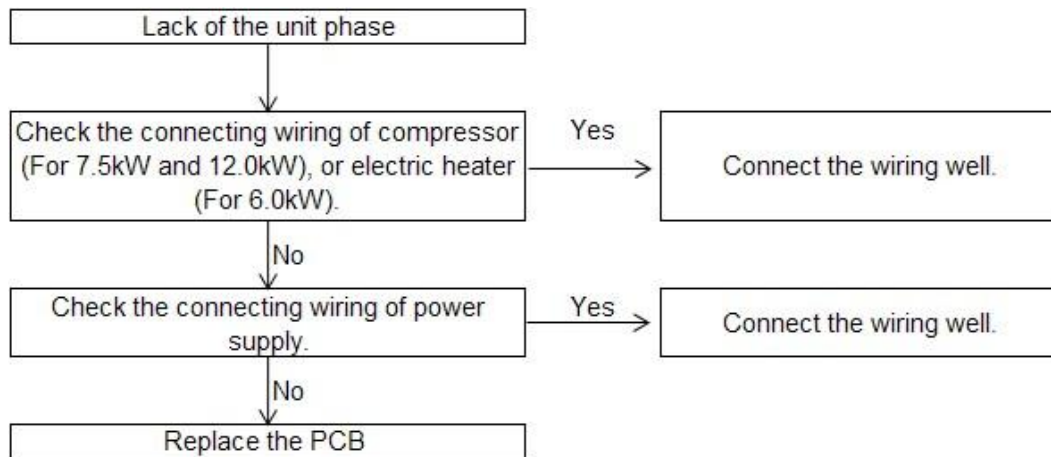

E8

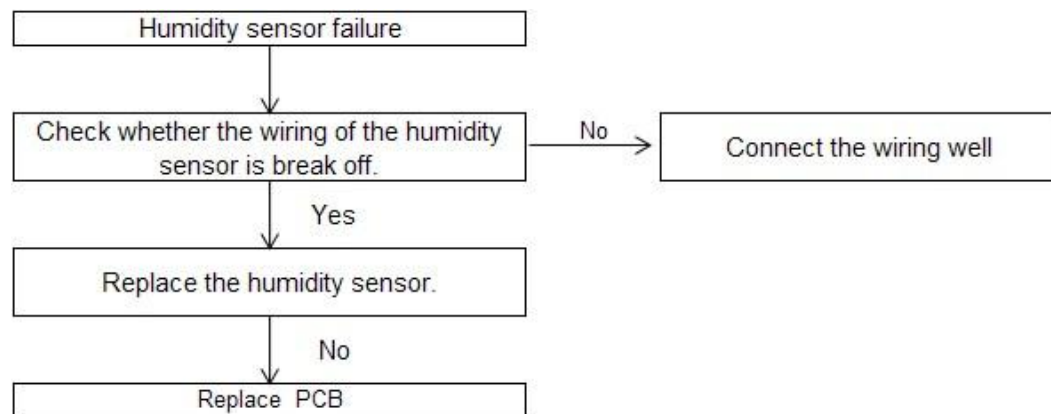

P1

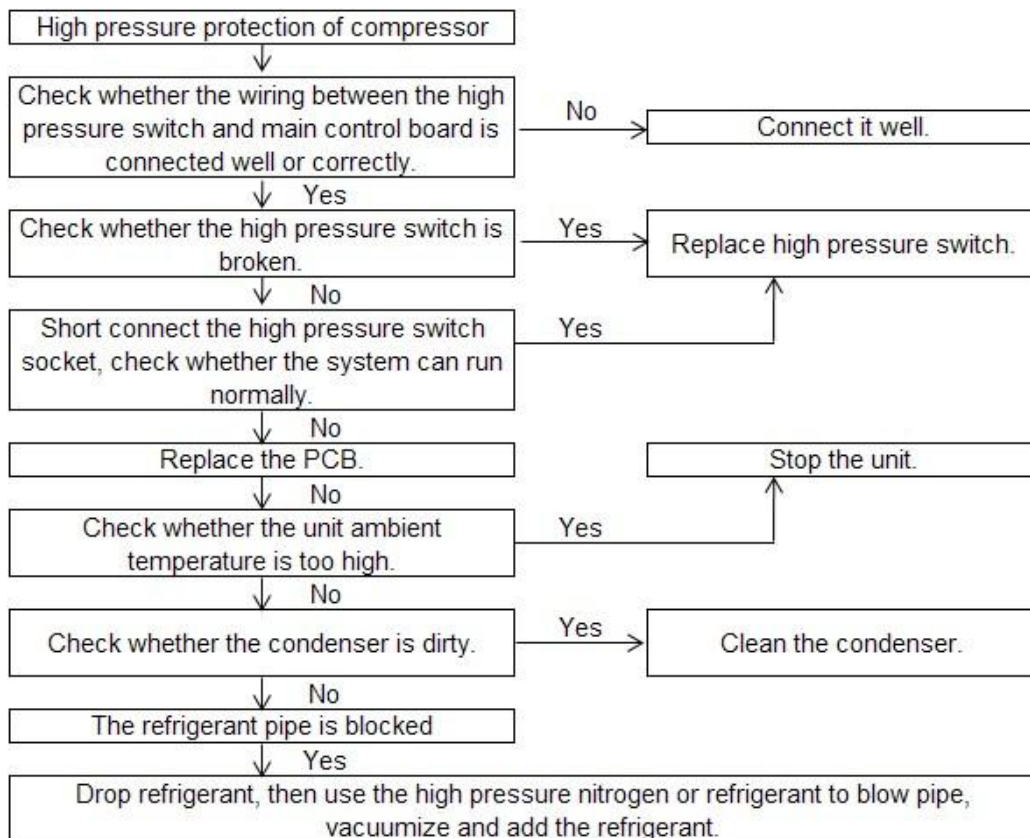

P2

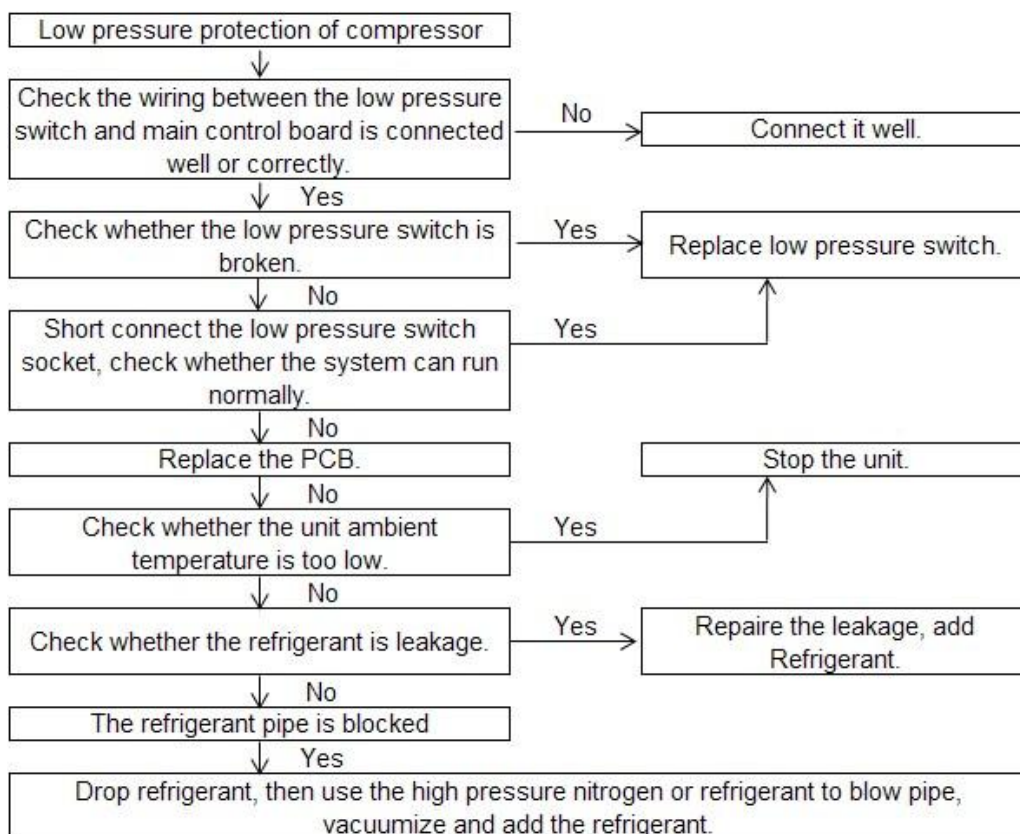

P3

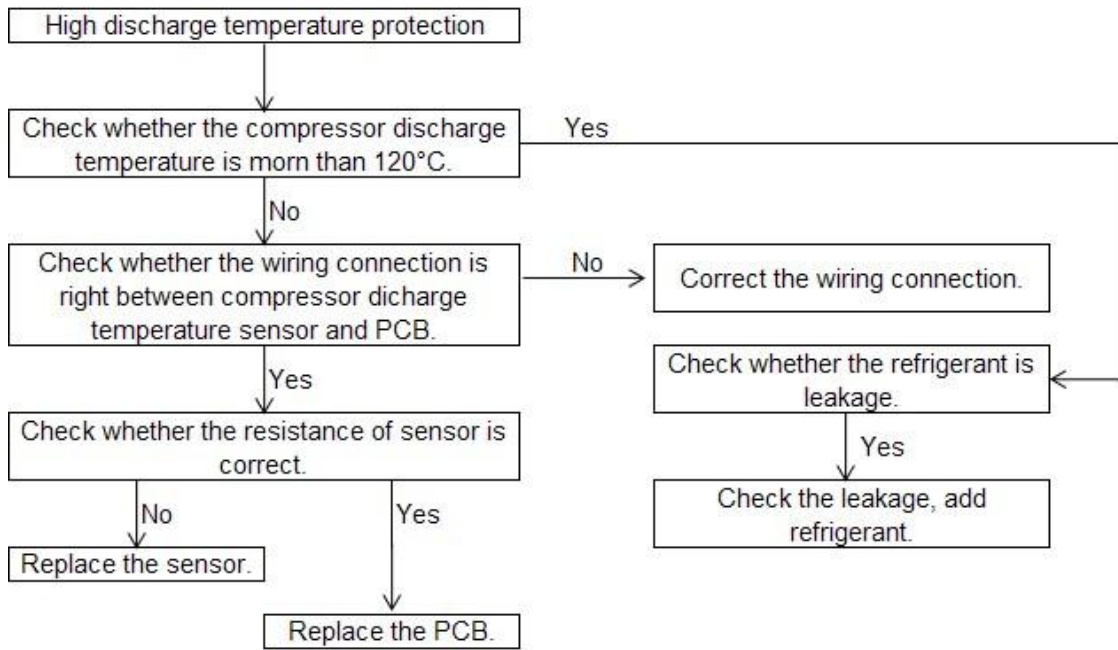

P4

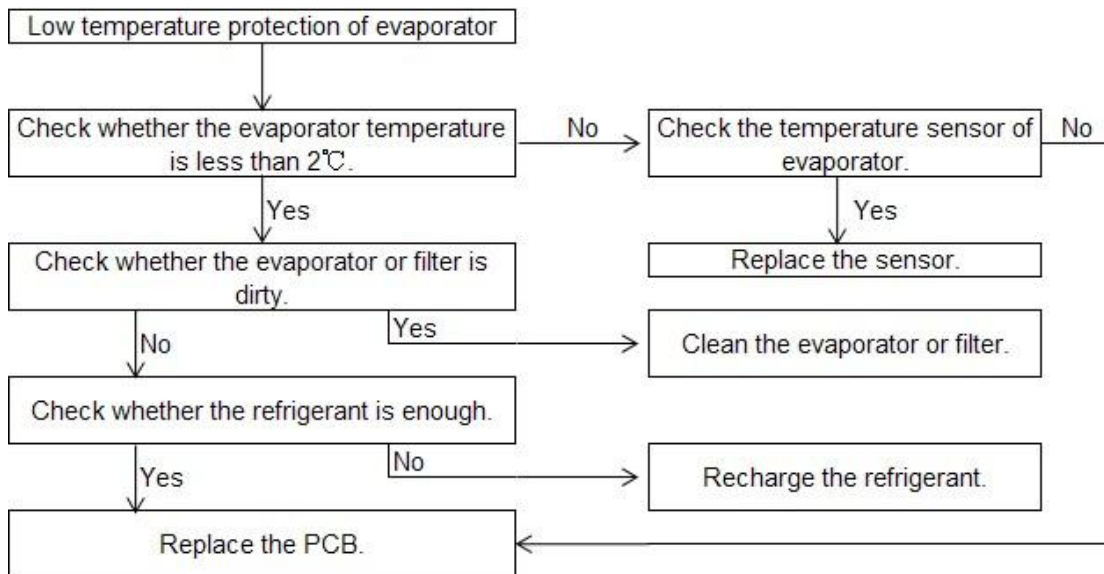

3.13 Function

Auto Mode

Under auto mode, the air conditioner will compare the room temperature with the setting temperature, automatically select the suitable operation. If auto mode operation is not suitable for you, it can select other operation mode.

Cool / Heat Mode

In the cool / heat mode, the temperature can be set.

When it is the cool operation, the free cooling function is default operated. When the room temperature is high than 16°C, the outdoor temperature is lower than 20°C, the humidity is higher than 80%, the air conditioner will switch to free cooling mode. When the outdoor temperature is higher than 21°C, or the humidity keep higher than 85% in 5 minutes, the air conditioner will exit free cooling mode with cool operation.

When it is the heat operation, the electric heater will be switch on till the room temperature is higher than the setting temperature.

Dry mode

The unit operates in the fixed temperature which is 15°C. At the same time, the indoor fan speed cannot be adjusted.

Compressor delay 3 min protection

To protect the compressor, after the compressor turn off, the compressor turn on after 3 minutes.

Power-down memory function

When the air conditioner re-connect to the power after power down, the unit will operate as the state before power down.

Dual units switch function

This function only is effective when setting the unit for main unit.

After set the dual units switch function, when switch time is up, if the formal main unit is operated, then the main unit will be closed, and operate the slave unit. If the formal slave unit is operated, then close the slave unit, operate the main unit.

If when the operating the main unit has error, then the slave unit will be operated automatically. If the slave unit has error, then the main unit will be operated automatically.

High/Low Temp Cascade function

This function only is effective when setting the unit for main unit. After set the high/low function, when the temperature of main unit is higher/lower the setting high/low temperature, it will force the main and slave unit operate the setting temperature to be cool/heat mode with locked temperature at the same time. When the temperature which checked by the main unit is lower/higher the setting high/low temperature 2°C, the main unit will recover to the previous operating state, and the slave unit will automatically off.

Temperature locking function

The first power on, auto and cool default temperature locking value is 27°C (it is can be set), and heat default temperature locking value is 25°C (it is can be set). When the function is on, adjust setting the temperature through the buttons, after 1 hour, the setting temperature will automatically be adjusted to the temperature locking value of the current mode.

Notes:

1. Temperature set through upper unit will not automatically be adjusted to the set temperature locking value.
2. When the slave and main units are correctly connected, the slave unit cannot set the temperature locking value of each mode.
3. No matter whether the slave and main units are correctly connected or not, the main unit can set temperature locking value under any mode.

3.14 Operation

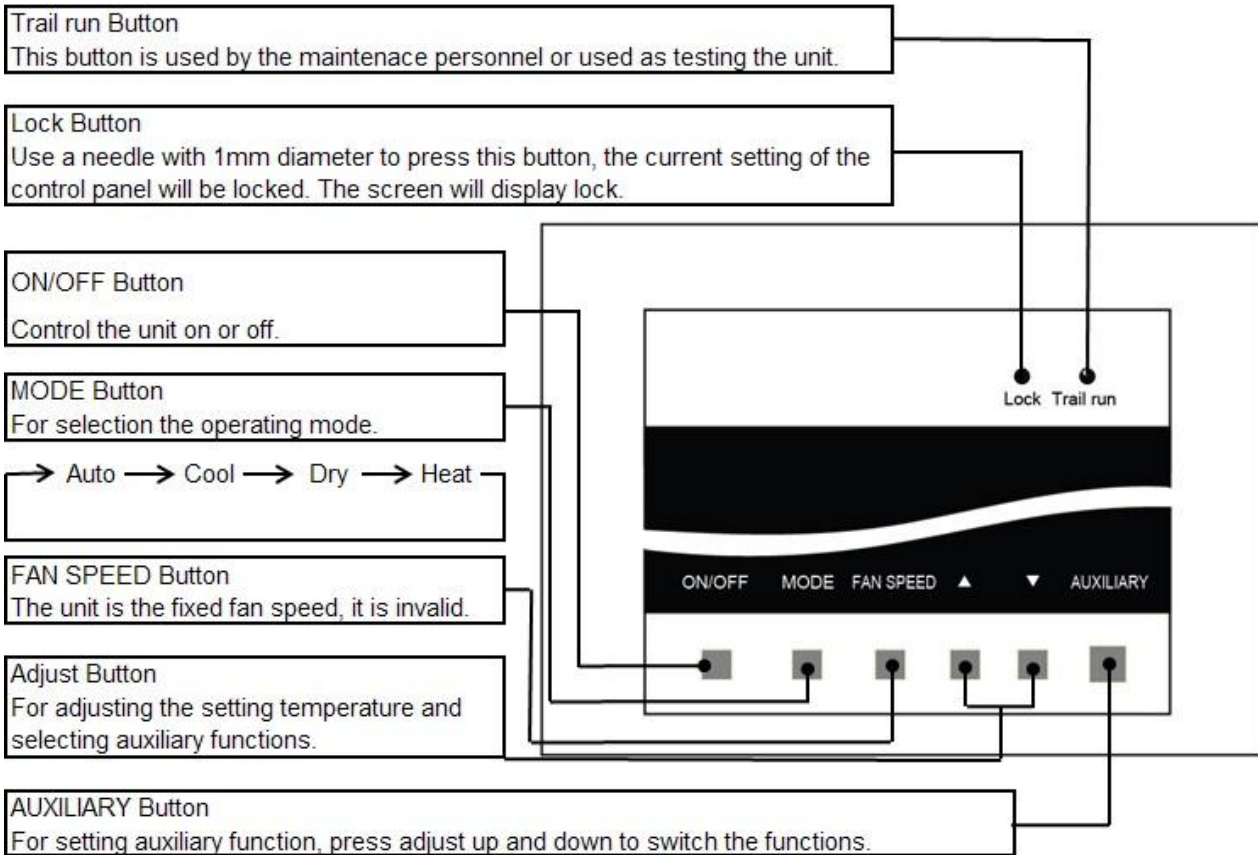

Auto operation

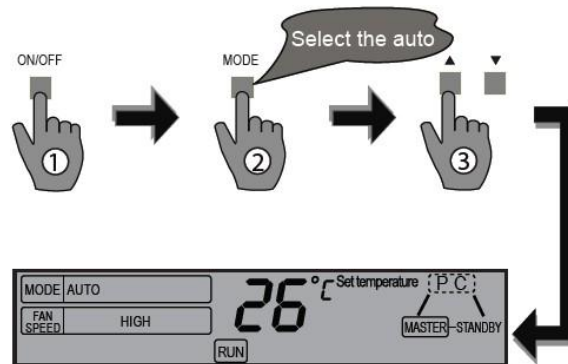

- ✧ Press the 'ON/OFF' button.
- ✧ Press the 'MODE' button, select the Auto.
- ✧ Press the 'Adjust' button, select the temperature, then the air conditioner will operate under the auto mode, meanwhile the fan speed will be auto controlled.
- ✧ Press the 'ON/OFF' button again, the unit will be stopped.

Cool / Heat operation

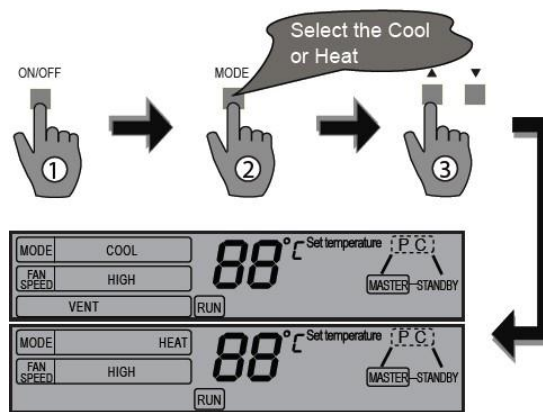

- ✧ Press the 'ON/OFF' button.
- ✧ Press the 'MODE' button, and select the Cool or Heat.
- ✧ Press the 'Adjust' button, select the temperature. The air conditioner will operate under the cool or heat mode, the fan speed will be auto controlled.
- ✧ Press the 'ON/OFF' button again, the unit will be stopped.

Dry operation

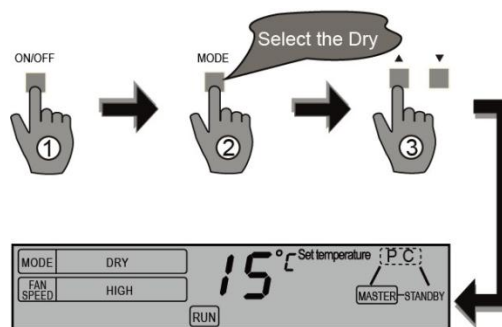

- ✧ Press the 'ON/OFF' button.
- ✧ Press the 'MODE' button, and select the Dry mode. The air conditioner will operate in dry mode with the setting temperature is 15°C, the fan speed will be auto controlled.
- ✧ Press the 'ON/OFF' button again, the unit will be stopped.

Main and slave unit setting (Available for Dual units)

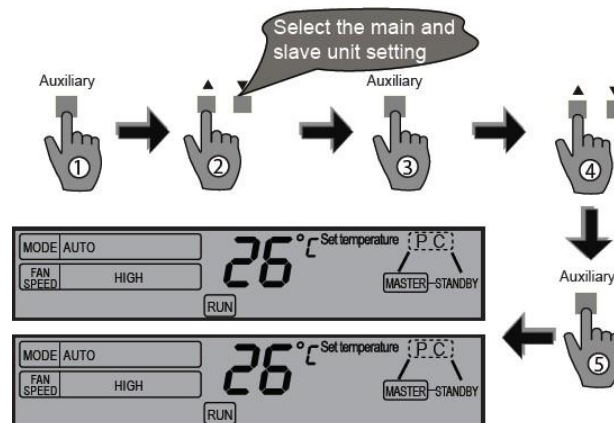

- ✧ Press the 'Auxiliary' button.
- ✧ Press the 'Adjust' button to select the Main and slave unit setting.
- ✧ Press the 'Auxiliary' button again for confirmation.
- ✧ Press the 'Adjust' button, set the air conditioner to be the main or slave unit.
- ✧ Press the 'Auxiliary' button again for confirmation.

High and Low Temp cascade (Available for Dual units)

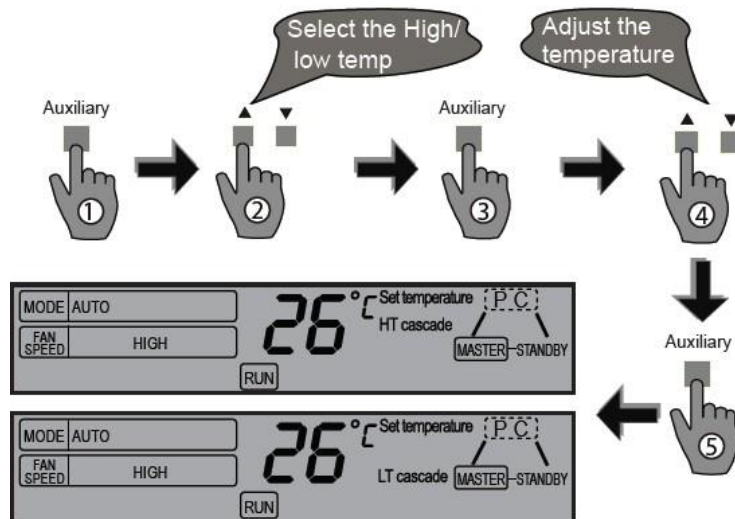

- ✧ Press the 'Auxiliary' button.
- ✧ Press the 'Adjust' button to select the High/low temp.
- ✧ Press the 'Auxiliary' button again for confirmation.
- ✧ Press the 'Adjust' button to select the high/low temp to be the one which you need, every press the button will add 1°C.
- ✧ Press the 'Auxiliary' button again for confirmation.
- ✧ To switch off the function, press the 'Auxiliary' button and the 'Adjust' button again to select High/low temp and press the 'Auxiliary' button for confirmation.

Dual units switch (Available for Dual units)

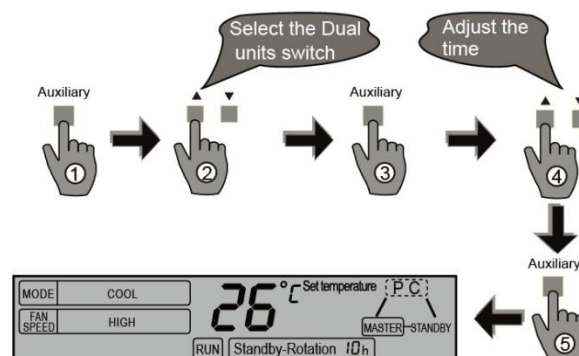

- ✧ Press the 'Auxiliary' button.
- ✧ Press the 'Adjust' button to select the Dual units switch.
- ✧ Press the 'Auxiliary' button again for confirmation, then the screen display 'Stand-Rotation 12h'.
- ✧ Press the 'Adjust' button to select the dual units switch hours to be the one you need, (Factory

setting 12 hours), every press the button will add 1 hour.

- ✧ To close the dual units switch function, press the 'Auxiliary' and 'Adjust' button again to select dual units switch and press 'Auxiliary' for confirmation.

New fan (Free cooling function)

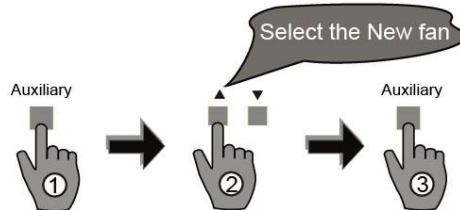

- ✧ Press the 'Auxiliary' button.
- ✧ Press the 'Adjust' button to select the new fan, the screen will show 'VENT'.
- ✧ Press the 'Auxiliary' button again for confirmation.
- ✧ Repeat the steps, the new fan function will be closed. (Factory setting the function is on.)

Notes: Available for cool mode.

Temperature query

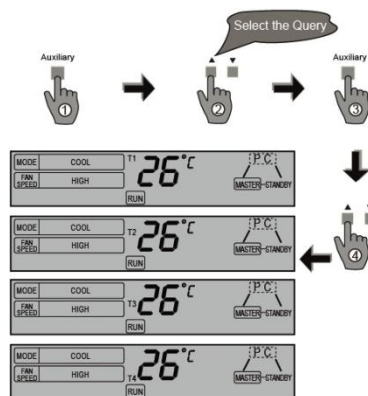

- ✧ Press the 'Auxiliary' button.
- ✧ Press the 'Adjust' button to select the query, the screen will show 'Query'.
- ✧ Press the 'Auxiliary' button again for confirmation.
- ✧ Press the 'Adjust' button, then will one by one display T1, T2, T3, T4 temperature, humidity or protection code (Without the protection, no display.).

Notes: Humidity is showed by percentage.

Value of T3 is always 25°C.

The upper and lower temperature limits setting

- ✧ Confirm the unit is under the power off and no central control order.
- ✧ For dual units, the slave unit only is set when it is not connecting with the main unit. The main unit anytime can be set.
- ✧ Under power off, press the 'Mode' button 5 or more than 5 times in 8 seconds, the screen will flash the lower limit value of current setting temperature.
- ✧ Press the 'Adjust' button to select the temperature which you need, and then in 8 seconds after the last press, press the 'Auxiliary' button for confirmation, so the lower temperature