

# Content

<b>Part 1</b>	<b>General Information</b> .....	1
<b>Part 2</b>	<b>Indoor Units</b> .....	4
<b>Part 3</b>	<b>Outdoor Units</b> .....	50
<b>Part 4</b>	<b>Installation</b> .....	65

## Part 1 General Information

<b>1. Model Names of Indoor/Outdoor Units</b> .....	1
<b>2. External Appearance</b> .....	2
<b>3. Nomenclature</b> .....	3

### 1. Model Names of Indoor/Outdoor Units

#### 1.1 Model Names of Units with Cooling only:



Type	Indoor unit		Outdoor unit		Capacity		
	Model	Power supply	Model	Power supply	kW	kBtu/h	
Floor-standing type	M DFA-76CRN2	220~240V-1N-50Hz	MOV-76C-CN2	380~415V-3N-50Hz	22	76	
	M DFA-96CRN2		MOV-96C-CN2		28	96	
Mid-static pressure duct type	M DTA-76CRN2		MOV-76C-CN2		380~400V-3N-50Hz	22	76
	M DTA-96CRN2		MOV-96C-CN2			28	96
	M DTA-120CRN2		MOV-120C-CN2	35	120		

**1.2 Model Names of Units with Cooling and heating:**

Type	Indoor unit		Outdoor unit		Capacity		
	Model	Power supply	Model	Power supply	kW	kBtu/h	
Floor-standing type	MDFA-76HRN2	220~240V-1N-50Hz	MOV-76H-CN2	380~415V-3N-50Hz	22	76	
	MDFA-96HRN2		MOV-96H-CN2		28	96	
Mid-static pressure duct type	MDTA-76HRN2		MOV-76H-CN2		380~400V-3N-50Hz	22	76
	MDTA-96HRN2		MOV-96H-CN2			28	96
	MDTA-120HRN2		MOV-120H-CN2	35	120		

**2. External Appearance**

**2.1 Indoor Units**

<p><b>MDTA-76C(H)RN2</b> <b>MDTA-96C(H)RN2</b></p>	<p><b>MDFA-76C(H)RN2</b> <b>MDFA-96C(H)RN2</b></p>
	
<p><b>MDTA-120C(H)RN2</b></p>	
	

## 2.2 Outdoor Unit



## 3. Nomenclature

### 3.1 Indoor unit:

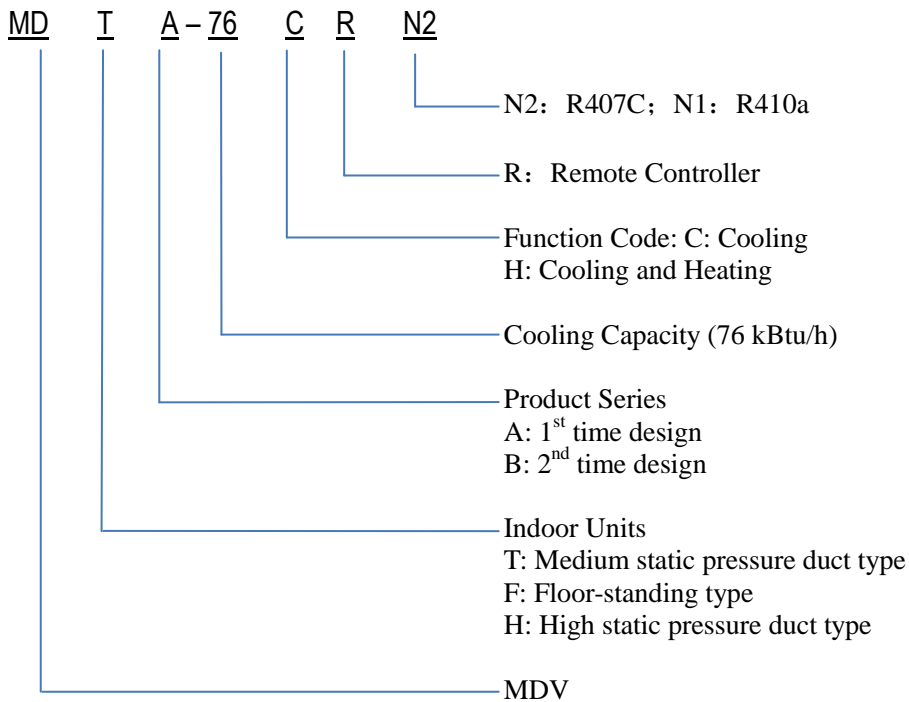

**3.2 Outdoor unit:**

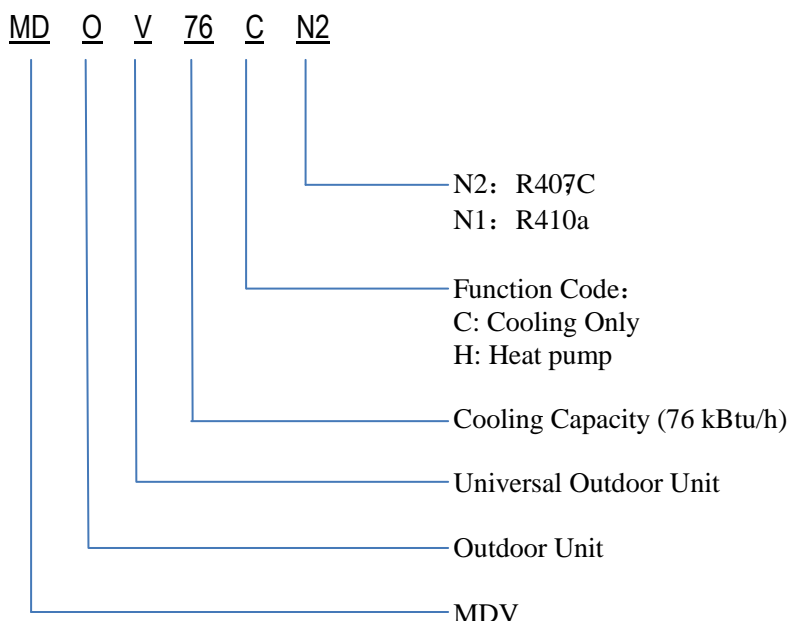

## Part 2 Indoor Units

Duct Type .....4

Floor-standing Type .....31

### Duct Type

1. Features .....5

2. Specifications .....5

3. Dimensions .....8

4. Service Space .....9

5. Refrigerant cycle Diagrams ..... 11

6. Wiring Diagrams ..... 11

7.Capacity Table ..... 15

8. Static Pressure .....21

9. Electric Characteristics .....22

10. Sound Levels .....23

12. Troubleshooting .....24



## 2. Specifications

Model			MDTA-76CRN2	MDTA-76HRN2	MDTA-96CRN2	MDTA-96HRN2
Code			220070900201	220070900191	220070900181	220070900171
Power supply		-	220~240V-1N-50Hz		220~240V-1N-50Hz	
Rated input power		W	11500	11500	14500	14700
Rated current		A	20	20	28	28.1
Cooling	Capacity	Btu/h	75,100	75,100	92,800	91,400
		W	22000	22000	27200	26800
	Input	W	7500	7500	9200	9200
	EER	W/W	2.93	2.93	2.96	2.91
Heating	Capacity	Btu/h	—	83600	—	109500
		W	—	24500	—	32100
	Input	W	—	7320	—	9800
	COP	W/W	—	3.35	—	3.28
Indoor air flow		m <sup>3</sup> /h(CFM)	4650(2700)	4650(2700)	5600(3300)	5600(3300)
Indoor external static pressure		Pa	100	100	100	100
Indoor noise level		dB(A)	54	54	55	55
Refrigerant	Type	-	R407C	R407C	R407C	R407C
	Control	-	Capillary	Capillary	Capillary	Capillary
Fan	Type	-	Centrifugal fan	Centrifugal fan	Centrifugal fan	Centrifugal fan
	Fan model	-	SYZ9-9MD	SYZ9-9MD	SYZ9-9MD	SYZ9-9MD
	Dimension	mm	Φ307	Φ307	Φ307	Φ307
	Drive type/ Motor step	-	Direct/ Single	Direct/ Single	Direct/ Single	Direct/ Single
	Motor model	-	YDK300-4X	YDK300-4X	YDK550-4X	YDK550-4X
	Motor Input * No.	W	720*2	720*2	1015*2	1015*2
	Motor speed	rpm	1040	1040	1300	1300
Coil	Type	-	Copper tube and aluminum fin	Copper tube and aluminum fin	Copper tube and aluminum fin	Copper tube and aluminum fin
	Tube size	mm	Φ9.52	Φ9.52	Φ9.52	Φ9.52
	No. of rows	-	4	4	4	4
	Fin per inch	FPI	17	17	17	17
	Length* height	mm	1200*406	1200*406	1200*406	1200*406
Controller		-	Remote controller		Remote controller	
Drain pipe size		mm	Φ41	Φ41	Φ41	Φ41
Connection wiring	Power wiring	mm <sup>2</sup>	3*2.5	3*2.5	3*2.5	3*2.5
	Signal wiring	mm <sup>2</sup>	2*1.0	4*1.0	2*1.0	4*1.0
Indoor unit	Dimension (W*H*D)	mm	1350*450*760	1350*450*760	1350*450*760	1350*450*760
	Packing (W*H*D)	mm	1549*476*917	1549*476*917	1549*476*917	1549*476*917
	Net/Gross weight	kg	105/120	105/120	105/120	105/120

### Notes:

1. ESP: external static pressure
2. Nominal cooling capacities are based on the following conditions:  
Indoor temp: 27°CDB, 19°CWB; Outdoor temp: 35°CDB, 24°CWB; Equivalent refrigerant piping: 7.5m (horizontal).
3. Nominal heating capacities are based on the following conditions:  
Indoor temp: 20°CDB, 15°CWB; Outdoor temp: 7°CDB, 6°CWB; Equivalent refrigerant piping: 7.5m (horizontal).

MCAC-UTSM-12

Model			MDTA-120CRN2	MDTA-120HRN2	
Code			220070900161	220070900151	
Power supply		-	220~240V-1N-50Hz		
Rated input power		W	18000	18000	
Rated current		A	28.7	28.7	
Cooling	Capacity	Btu/h	116,000	116,000	
		W	34000	34000	
	Input	W	11900	11900	
	EER	W/W	2.86	2.86	
Heating	Capacity	Btu/h	—	139900	
		W	—	41000	
	Input	W	—	12600	
	COP	W/W	—	3.25	
Indoor air flow		m <sup>3</sup> /h	6800	6800	
Indoor external static pressure		Pa	150	150	
Indoor noise level		dB(A)	56	56	
Refrigerant	Type	-	R407C	R407C	
	Control	-	Capillary	Capillary	
Fan	Type	-	Centrifugal fan	Centrifugal fan	
	Fan model	-	SYZ9-9MD	SYZ9-9MD	
	Dimension	mm	Φ307	Φ307	
	Drive type/ Motor step	-	Direct/ Single	Direct/ Single	
	Motor model	-	YDK300-4X	YDK300-4X	
	Motor Input * No.	W	720*3	720*3	
	Motor speed	rpm	1040/930/825	1040/930/825	
Coil	Type	-	Copper tube and aluminum fin	Copper tube and aluminum fin	
	Tube size	mm	Φ7	Φ7	
	No. of rows	-	4	4	
	Fin per inch	FPI	17	17	
	Length* height	mm	1602*588	1602*588	
Controller		-	Remote controller		
Drain pipe size		mm	Φ41	Φ41	
Connection wiring	Power wiring	mm <sup>2</sup>	3*2.5	3*2.5	
	Signal wiring	mm <sup>2</sup>	2*1.0	4*1.0	
Indoor unit	Dimension (W*H*D)	mm	1828*638*858	1828*638*858	
	Packing (W*H*D)	mm	2095*689*929	2095*689*929	
	Net/Gross weight	kg	188/220	188/220	

Notes:

1. ESP: external static pressure

2. Nominal cooling capacities are based on the following conditions:

Indoor temp: 27°CDB, 19°CWB; Outdoor temp: 35°CDB, 24°CWB; Equivalent refrigerant piping: 7.5m (horizontal).

3. Nominal heating capacities are based on the following conditions:

Indoor temp: 20°CDB, 15°CWB; Outdoor temp: 7°CDB, 6°CWB; Equivalent refrigerant piping: 7.5m (horizontal).

### 3. Dimensions

#### 3.1 MDTA-76C(H)RN2, MDTA-96C(H)RN2

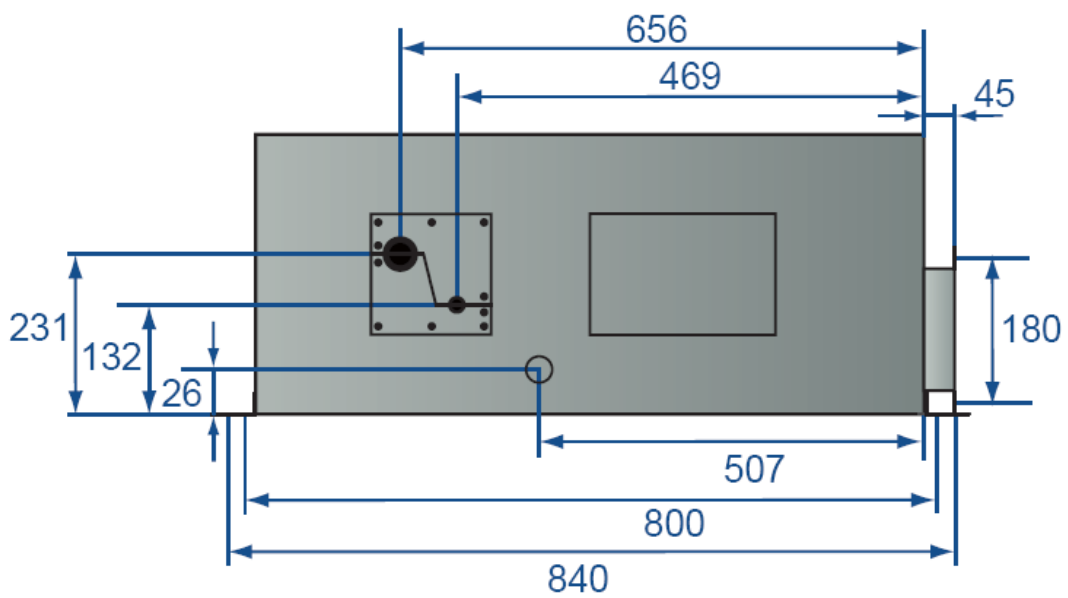
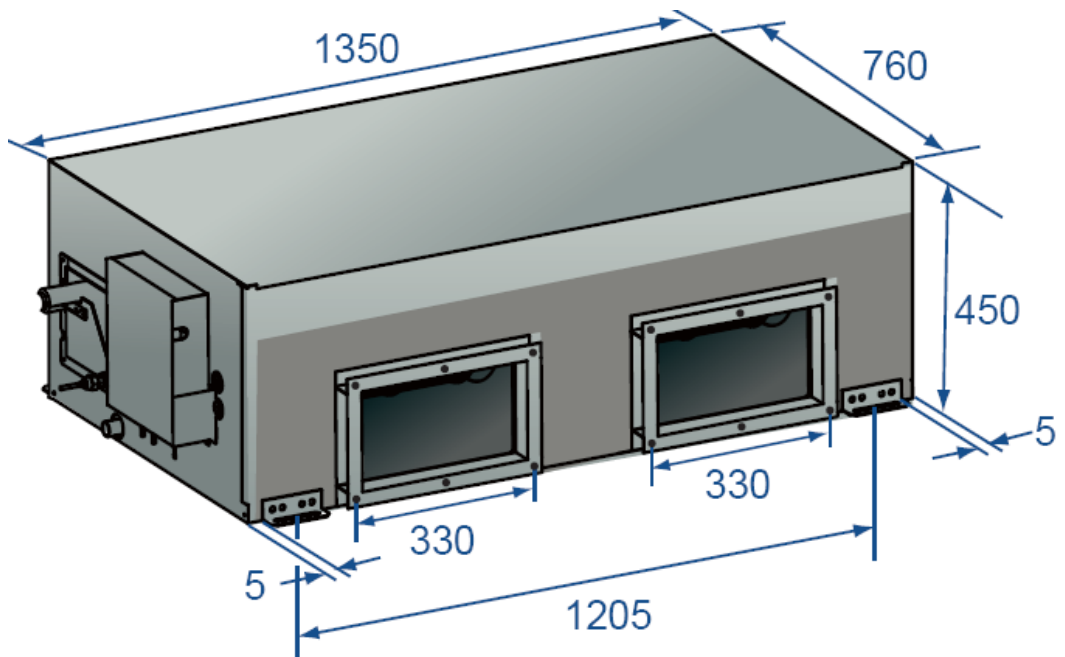

3.2 MDTA-120C(H)RN2

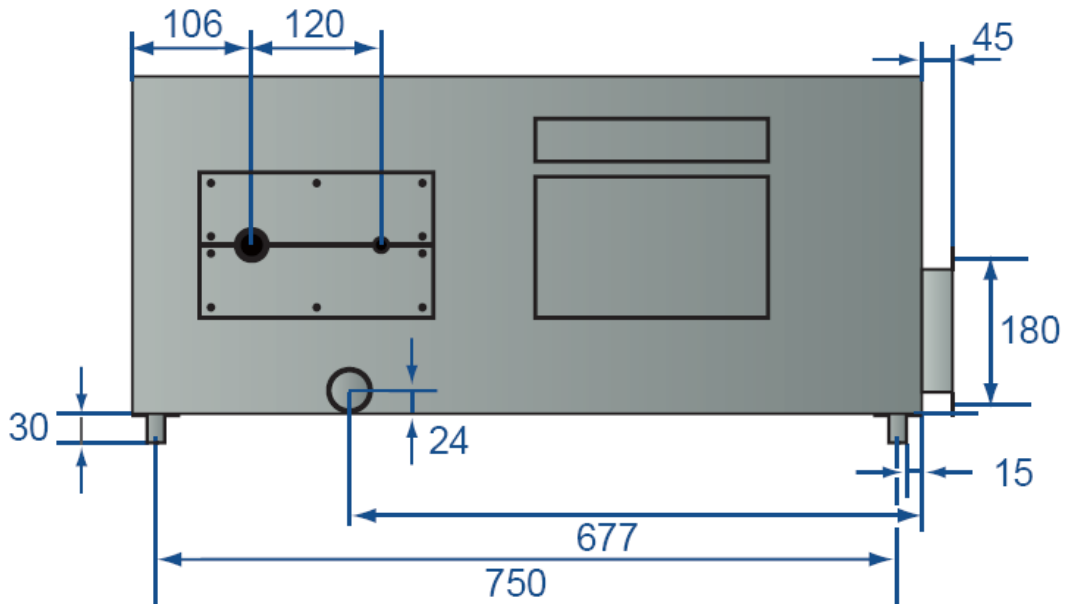
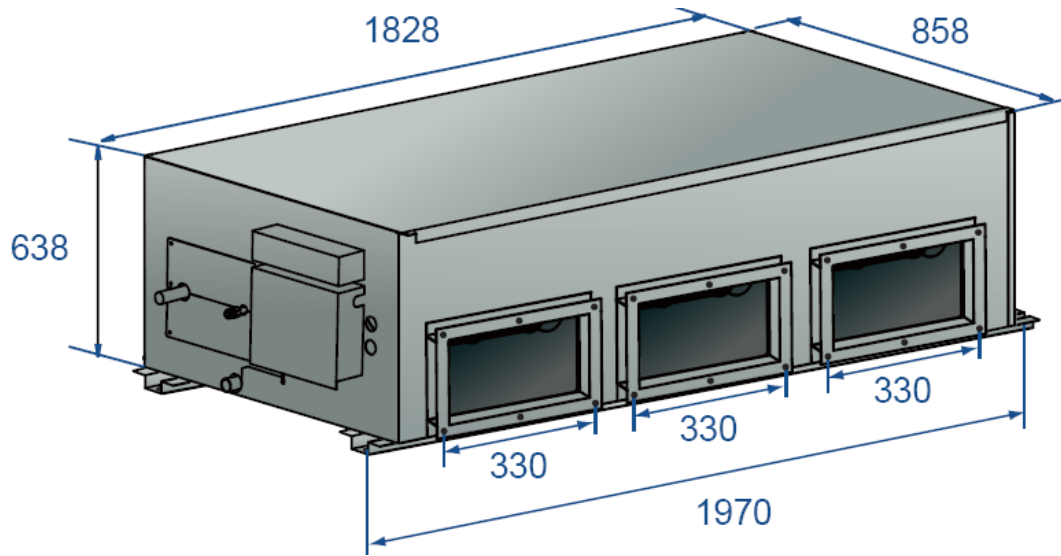

### 4. Service Space

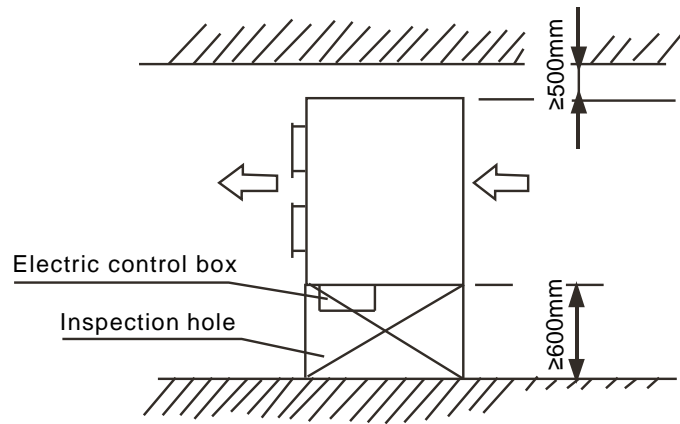

Top view

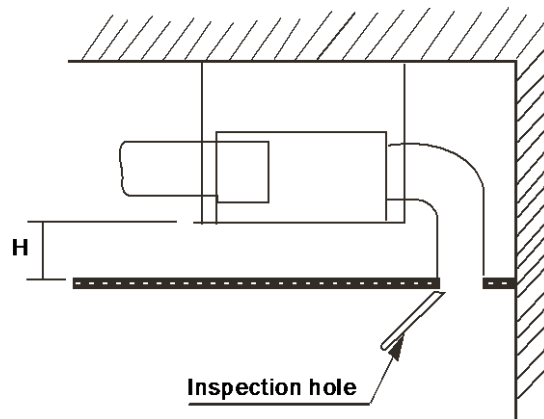

Side view

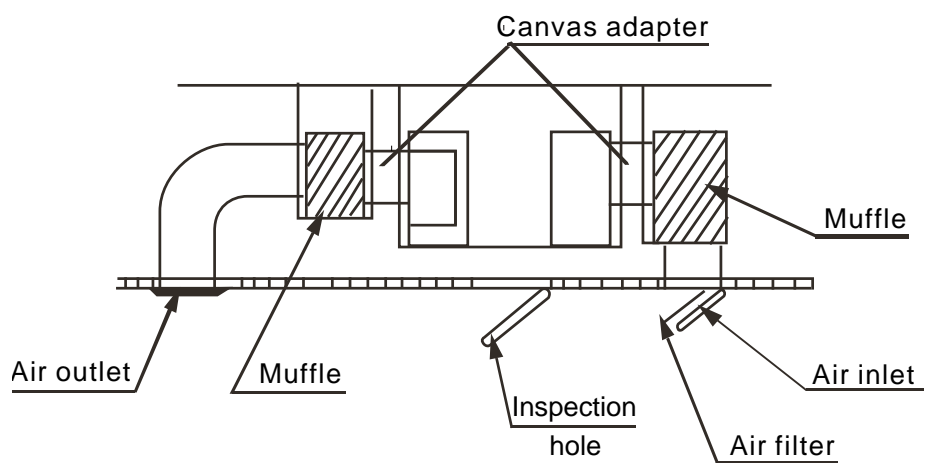

Air duct system

## 5. Refrigerant cycle diagrams

### 5.1 Cooling only: MDTA-76CRN2, MDTA-96CRN2, MDTA-120CRN2

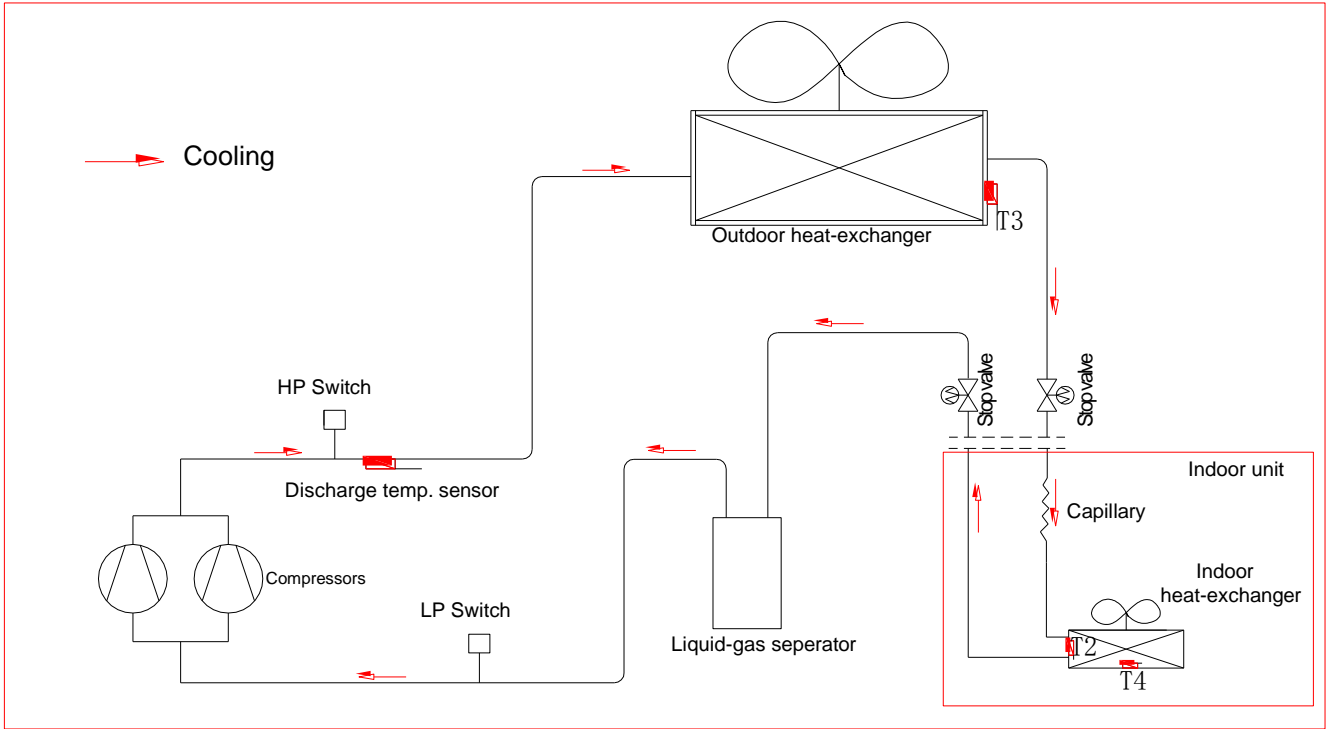

### 5.3 Cooling and heating: MDTA-76HRN2, MDTA-96HRN2, MDTA-120HRN2

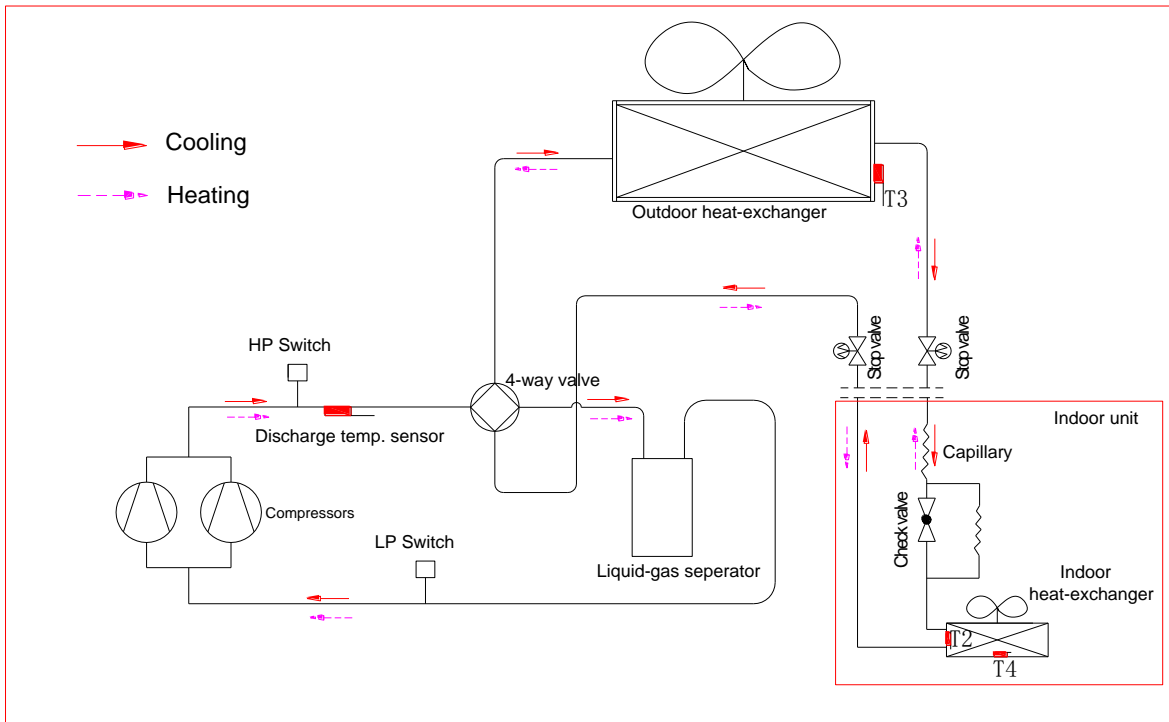

## 6. Wiring Diagrams

### 6.1 MDTA-76CRN2, MDTA-96CRN2

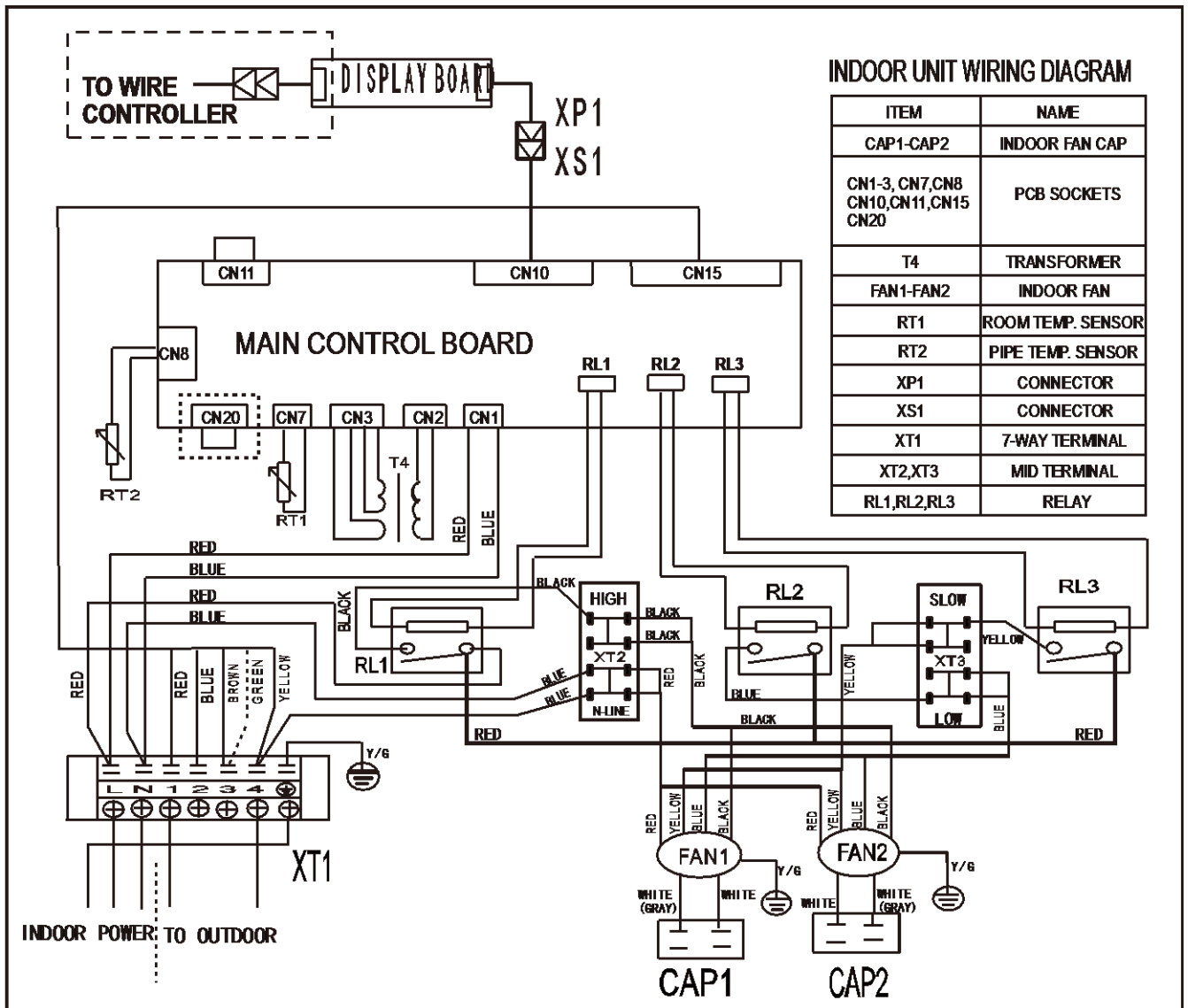

### 6.2 MDTA-76HRN2, MDTA-96HN2

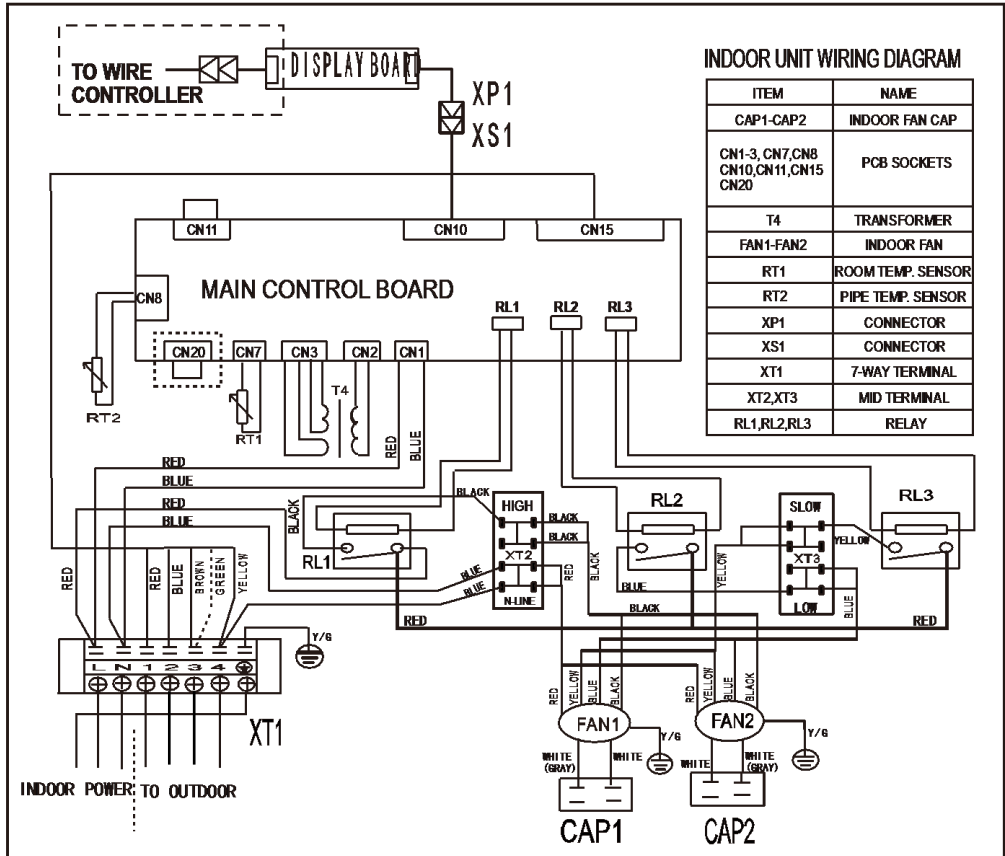

### 6.3 MDTA-120CRN2

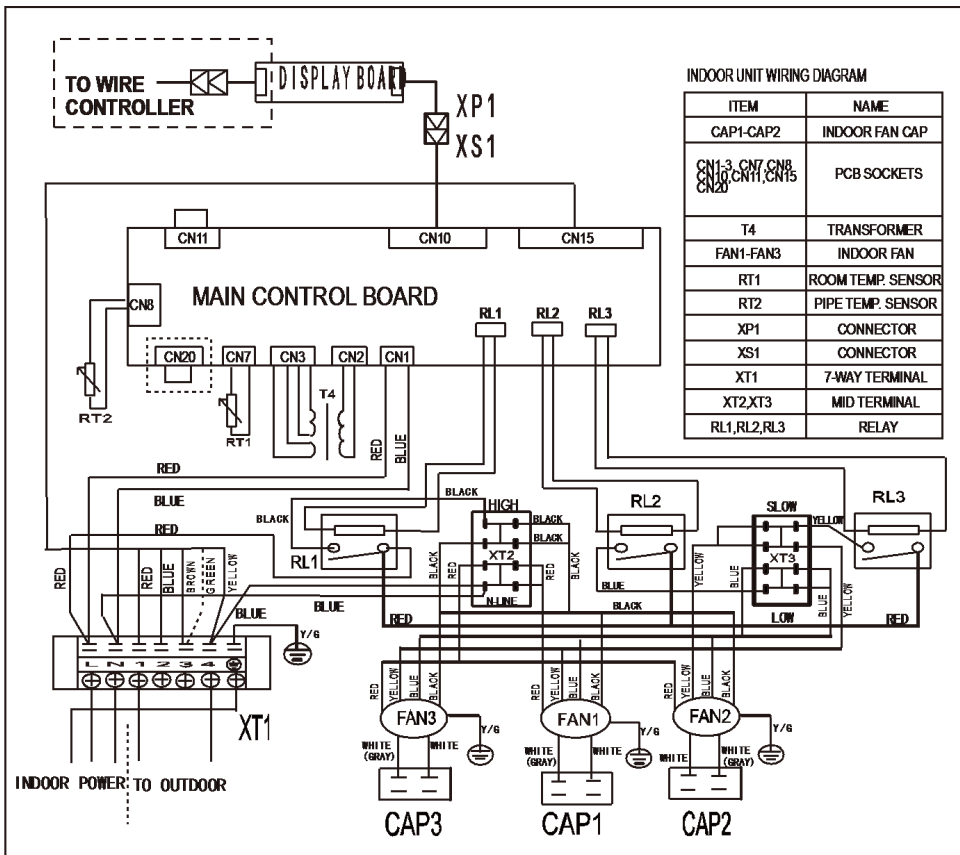



6.4 MDTA-120HRN2

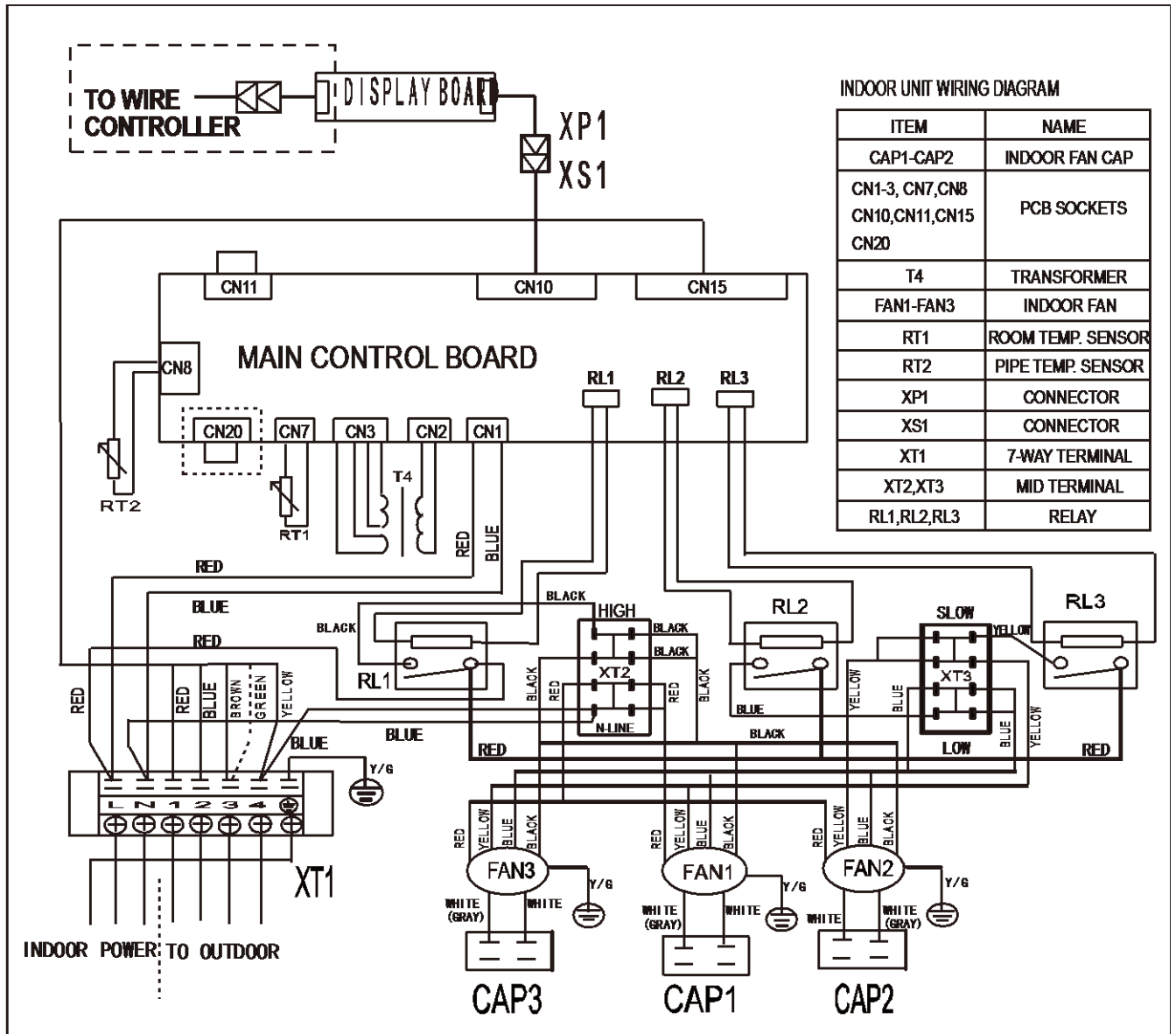

## 7. Capacity Table

### 7.1 76 kBtu/h

Gross Cooling Capacity (kW)																			
Outdoor DB(°C)		29.40									35.00								
Indoor	WB(°C)	16.10			19.40			22.80			16.10			19.40			22.80		
CFM	DB(°C)	TGC	SHC	PI	TGC	SHC	PI	TGC	SHC	PI	TGC	SHC	PI	TGC	SHC	PI	TGC	SHC	PI
2200	23.90	19.2	15.0	7.13	21.7	12.2	7.33	23.0	5.3	7.46	18.4	15.1	7.56	20.5	11.6	7.79	21.8	5.0	7.93
	26.70	19.9	17.2	7.15	22.1	14.3	7.35	23.5	10.1	7.48	18.8	17.1	7.58	20.9	13.5	7.81	22.2	9.6	7.95
	29.40	20.6	18.7	7.17	22.5	18.5	7.37	24.0	14.3	7.5	19.2	18.4	7.6	21.3	17.5	7.83	22.6	13.5	7.97
	32.20	21.3	20.9	7.19	23.0	20.9	7.39	24.4	18.0	7.52	19.6	19.2	7.62	21.7	19.8	7.85	23.1	17.0	7.99
2500	23.90	20.3	16.2	7.33	22.3	12.9	7.53	23.6	5.6	7.66	19.4	16.3	7.76	21.1	12.2	7.99	22.4	5.3	8.13
	26.70	21.0	18.3	7.35	22.7	16.1	7.55	24.1	10.6	7.68	19.8	18.3	7.78	21.5	15.3	8.01	22.8	10.0	8.15
	29.40	21.7	20.1	7.37	23.2	19.5	7.57	24.6	15.0	7.7	20.2	19.8	7.8	21.9	18.4	8.03	23.3	14.2	8.17
	32.20	22.5	21.4	7.39	23.6	21.9	7.59	25.1	18.7	7.72	20.6	20.6	7.82	22.4	20.7	8.05	23.7	17.7	8.19
2700	23.90	20.8	18.1	7.57	22.8	14.2	7.9	24.1	6.3	7.9	19.9	18.3	8	21.6	13.5	8.23	22.8	5.9	8.37
	26.70	21.5	20.5	7.59	23.2	17.9	7.79	24.6	11.8	7.92	20.3	20.3	8.02	22.0	16.9	8.25	23.3	11.2	8.39
	29.40	22.3	21.6	7.61	23.7	21.7	7.81	25.1	16.6	7.94	20.7	20.7	8.04	22.4	20.6	8.27	23.8	15.7	8.41
	32.20	23.0	22.6	7.63	24.1	21.9	7.83	25.6	20.8	7.96	21.1	21.1	8.06	22.9	20.8	8.29	24.2	19.7	8.43
3000	23.90	21.3	18.8	7.88	23.2	13.9	8.08	24.6	6.0	8.21	20.7	18.3	8.31	22.1	13.2	8.54	23.3	5.7	8.68
	26.70	22.0	21.2	7.9	23.7	17.4	8.1	25.1	11.4	8.23	21.1	20.3	8.33	22.5	16.5	8.56	23.8	10.8	8.7
	29.40	22.8	22.1	7.92	24.2	21.0	8.12	25.6	16.2	8.25	21.5	21.5	8.35	23.0	20.0	8.58	24.3	15.4	8.72
	32.20	23.6	23.1	7.94	24.7	23.7	8.14	26.1	20.2	8.27	22.0	22.0	8.37	23.4	22.5	8.6	24.8	19.2	8.74

Gross Cooling Capacity (kW)																												
Outdoor DB(°C)		40.60									46.10									51.70								
Indoor	WB(°C)	16.10			19.40			22.80			16.10			19.40			22.80			16.10			19.40			22.80		
CFM	DB(°C)	TGC	SHC	PI	TGC	SHC	PI	TGC	SHC	PI	TGC	SHC	PI	TGC	SHC	PI	TGC	SHC	PI	TGC	SHC	PI	TGC	SHC	PI	TGC	SHC	PI
2200	23.9	18.41	15.09	8.49	19.98	11.29	8.73	21.25	4.91	8.88	16.9	13.9	8.68	18.4	10.4	8.94	19.6	4.5	9.19	16.1	13.2	10.67	17.3	9.8	11.03	18.4	4.3	11.28
	26.7	18.78	17.07	8.51	20.38	13.2	8.75	21.68	9.34	8.9	17.3	15.7	8.7	18.8	12.2	8.96	20.0	8.6	9.21	16.4	14.9	10.7	17.7	11.5	11.06	18.8	8.1	11.31
	29.4	19.16	18.42	8.53	20.79	17.04	8.77	22.11	13.16	8.92	17.6	17.0	8.72	19.2	15.7	8.98	20.4	12.1	9.23	16.7	16.1	10.73	18.0	14.8	11.09	19.2	11.4	11.34
	32.2	19.54	19.16	8.55	21.2	19.28	8.79	22.56	16.59	8.94	18.0	17.6	8.74	19.5	17.8	9	20.8	15.3	9.26	17.0	16.7	10.75	18.4	16.7	11.12	19.5	14.4	11.37
2500	23.9	19.02	15.98	8.69	20.59	11.9	8.93	21.86	5.16	9.08	17.6	14.8	8.88	19.0	11.0	9.14	20.2	4.8	9.39	16.7	14.0	10.87	17.9	10.4	11.23	19.0	4.5	11.48
	26.7	19.4	17.96	8.71	21	14.89	8.95	22.3	9.78	9.1	17.9	16.6	8.9	19.4	13.8	9.16	20.6	9.0	9.41	17.0	15.7	10.9	18.3	13.0	11.26	19.4	8.5	11.51
	29.4	19.79	19.4	8.73	21.42	18	8.97	22.75	13.87	9.12	18.3	17.9	8.92	19.8	16.6	9.18	21.0	12.8	9.43	17.3	17.0	10.93	18.7	15.7	11.29	19.8	12.1	11.54
	32.2	20.18	20.18	8.75	21.85	20.23	8.99	23.2	17.31	9.15	18.6	18.6	8.94	20.2	18.7	9.21	21.4	16.0	9.46	17.7	17.7	10.95	19.0	17.6	11.32	20.2	15.1	11.57
2700	23.9	19.51	17.9	8.39	21.08	13.17	8.78	22.35	5.79	8.78	18.0	16.6	9.12	19.5	12.2	9.38	20.7	5.4	9.63	17.2	15.7	11.11	18.4	11.5	11.47	19.5	5.1	11.72
	26.7	19.9	19.9	8.41	21.5	16.54	8.65	22.8	10.91	8.8	18.4	18.4	9.14	19.9	15.3	9.4	21.1	10.1	9.65	17.5	17.5	11.14	18.8	14.5	11.5	19.9	9.5	11.75
	29.4	20.3	20.3	8.43	21.93	20.12	8.67	23.26	15.4	8.82	18.8	18.8	9.16	20.3	18.6	9.42	21.5	14.3	9.67	17.9	17.9	11.17	19.2	17.6	11.53	20.3	13.4	11.78
	32.2	20.7	20.7	8.45	22.37	20.34	8.69	23.72	19.29	8.84	19.1	19.1	9.19	20.7	18.8	9.45	22.0	17.9	9.7	18.2	18.2	11.2	19.6	17.8	11.56	20.7	16.8	11.81
3000	23.9	20	17.7	9.24	21.57	12.92	9.48	22.84	5.6	9.63	18.5	16.4	9.43	20.0	12.0	9.69	21.2	5.2	9.94	17.7	15.6	11.42	18.9	11.3	11.78	20.0	4.9	12.03
	26.7	20.4	19.62	9.26	22	16.18	9.5	23.3	10.59	9.65	18.9	18.2	9.45	20.4	15.0	9.71	21.6	9.8	9.96	18.0	17.3	11.45	19.3	14.2	11.81	20.4	9.3	12.06
	29.4	20.81	20.81	9.28	22.44	19.51	9.52	23.77	15.04	9.67	19.3	19.3	9.47	20.8	18.1	9.73	22.0	13.9	9.98	18.4	18.4	11.48	19.7	17.1	11.84	20.8	13.2	12.09
	32.2	21.22	21.22	9.31	22.89	22.01	9.55	24.24	18.79	9.7	19.7	19.7	9.5	21.2	20.4	9.76	22.5	17.4	10.01	18.7	18.7	11.51	20.1	19.3	11.87	21.2	16.5	12.12

Notes:

1. DB = Dry Bulb Temperature (°C), WB = Wet Bulb Temperature (°C)
4. TGC = Total Cooling Capacity (kW)
5. SHC = Sensible Heating Capacity (kW)
6. PI = Power Input (kW)

**7.1 96 kBtu/h**

Gross Cooling Capacity (kW)																			
Outdoor DB(°C)		29.40									35.00								
Indoor	WB(°C)	16.10			19.40			22.80			16.10			19.40			22.80		
CFM	DB(°C)	TGC	SHC	PI	TGC	SHC	PI	TGC	SHC	PI	TGC	SHC	PI	TGC	SHC	PI	TGC	SHC	PI
2700	23.9	24.3	19.0	9.38	26.8	15.1	9.58	28.1	6.5	9.71	23.5	19.3	9.81	25.6	14.5	10.03	26.8	6.2	10.17
	26.7	25.1	21.6	9.4	27.3	17.7	9.6	28.7	12.4	9.73	24.0	21.8	9.83	26.1	16.9	10.06	27.4	11.8	10.2
	29.4	26.0	23.6	9.42	27.8	22.8	9.62	29.3	17.4	9.75	24.5	23.5	9.85	26.6	21.8	10.09	27.9	16.6	10.23
	32.2	26.9	26.4	9.45	28.4	25.8	9.65	29.8	21.9	9.78	25.0	24.5	9.88	27.1	24.7	10.11	28.5	21.0	10.25
3000	23.9	25.3	20.3	9.58	27.4	15.8	9.78	28.7	6.8	9.91	24.5	20.6	10	26.2	15.1	10.23	27.5	6.5	10.37
	26.7	26.2	22.8	9.6	27.9	19.8	9.8	29.3	12.9	9.93	25.0	23.2	10.03	26.7	18.9	10.26	28.0	12.3	10.4
	29.4	27.1	25.1	9.62	28.5	23.9	9.82	29.9	18.2	9.95	25.5	25.0	10.06	27.2	22.9	10.29	28.6	17.4	10.43
	32.2	28.1	26.7	9.65	29.0	26.9	9.85	30.5	22.8	9.98	26.0	26.0	10.08	27.8	25.7	10.31	29.1	21.7	10.45
3260	23.9	25.8	22.4	9.82	27.8	17.4	10.14	29.2	7.6	10.14	25.0	22.9	10.24	26.7	16.7	10.47	27.9	7.2	10.61
	26.7	26.7	25.4	9.84	28.4	21.9	10.04	29.8	14.3	10.17	25.5	25.5	10.27	27.2	20.9	10.5	28.5	13.6	10.64
	29.4	27.6	26.8	9.86	29.0	26.6	10.07	30.4	20.1	10.2	26.0	26.0	10.3	27.7	25.5	10.53	29.1	19.3	10.67
	32.2	28.6	28.0	9.89	29.6	26.9	10.09	31.0	25.2	10.22	26.5	26.5	10.32	28.3	25.7	10.55	29.7	24.1	10.69
3500	23.9	26.3	23.3	10.12	28.3	17.0	10.32	29.7	7.3	10.45	25.8	22.8	10.55	27.2	16.3	10.78	28.4	7.0	10.92
	26.7	27.2	26.2	10.15	28.9	21.3	10.35	30.3	13.8	10.48	26.3	25.3	10.58	27.7	20.4	10.81	29.0	13.2	10.95
	29.4	28.2	27.3	10.18	29.5	25.6	10.38	30.9	19.6	10.51	26.8	26.8	10.61	28.3	24.6	10.84	29.6	18.7	10.98
	32.2	29.1	28.6	10.2	30.1	28.9	10.4	31.5	24.4	10.53	27.4	27.4	10.63	28.8	27.7	10.86	30.2	23.4	11

Gross Cooling Capacity (kW)																												
Outdoor DB(°C)		40.60									46.10									51.70								
Indoor	WB(°C)	16.10			19.40			22.80			16.10			19.40			22.80			16.10			19.40			22.80		
CFM	DB(°C)	TGC	SHC	PI	TGC	SHC	PI	TGC	SHC	PI	TGC	SHC	PI	TGC	SHC	PI	TGC	SHC	PI	TGC	SHC	PI	TGC	SHC	PI	TGC	SHC	PI
2700	23.9	23.8	19.5	10.85	25.4	14.3	11.09	26.7	6.2	11.24	22.3	18.3	11.04	23.8	13.5	11.3	25.0	5.8	11.55	19.6	16.1	12.37	20.9	11.8	12.73	21.9	5.1	12.98
	26.7	24.3	22.1	10.88	25.9	16.8	11.12	27.2	11.7	11.27	22.8	20.7	11.07	24.3	15.7	11.33	25.5	11.0	11.58	20.0	18.2	12.4	21.3	13.8	12.76	22.4	9.7	13.01
	29.4	24.8	23.8	10.91	26.4	21.6	11.15	27.7	16.5	11.3	23.2	22.3	11.1	24.8	20.3	11.36	26.0	15.5	11.61	20.4	19.6	12.43	21.7	17.8	12.79	22.8	13.6	13.04
	32.2	25.3	24.8	10.93	26.9	24.5	11.18	28.3	20.8	11.33	23.7	23.2	11.13	25.3	23.0	11.39	26.5	19.5	11.64	20.8	20.4	12.46	22.1	20.1	12.82	23.3	17.1	13.08
3000	23.9	24.4	20.5	11.05	26.0	15.0	11.29	27.3	6.4	11.44	22.9	19.3	11.24	24.4	14.1	11.5	25.6	6.0	11.75	20.2	17.0	12.57	21.5	12.4	12.93	22.6	5.3	13.18
	26.7	24.9	23.1	11.08	26.5	18.8	11.32	27.8	12.2	11.47	23.4	21.7	11.27	24.9	17.7	11.53	26.1	11.5	11.78	20.6	19.1	12.6	21.9	15.5	12.96	23.0	10.1	13.21
	29.4	25.4	24.9	11.11	27.0	22.7	11.35	28.4	17.3	11.5	23.9	23.4	11.3	25.4	21.3	11.56	26.6	16.2	11.81	21.0	20.6	12.63	22.3	18.8	12.99	23.5	14.3	13.24
	32.2	25.9	25.9	11.14	27.6	25.5	11.38	28.9	21.6	11.53	24.4	24.4	11.33	25.9	24.0	11.59	27.2	20.3	11.84	21.4	21.4	12.66	22.8	21.1	13.02	23.9	17.9	13.28
3260	23.9	24.9	22.9	11.29	26.5	16.5	11.68	27.8	7.2	11.68	23.4	21.5	11.48	24.9	15.6	11.74	26.1	6.8	11.99	20.7	19.0	12.81	22.0	13.7	13.17	23.0	6.0	13.42
	26.7	25.4	25.4	11.32	27.0	20.8	11.56	28.3	13.5	11.71	23.9	23.9	11.51	25.4	19.5	11.77	26.6	12.7	12.02	21.1	21.1	12.84	22.4	17.2	13.2	23.5	11.2	13.45
	29.4	25.9	25.9	11.35	27.5	25.3	11.59	28.9	19.1	11.74	24.4	24.4	11.54	25.9	23.8	11.8	27.1	18.0	12.05	21.5	21.5	12.87	22.9	21.0	13.23	24.0	15.9	13.48
	32.2	26.4	26.4	11.38	28.1	25.5	11.62	29.4	23.9	11.77	24.9	24.9	11.57	26.4	24.0	11.83	27.7	22.5	12.08	22.0	22.0	12.9	23.3	21.2	13.27	24.5	19.9	13.52
3500	23.9	25.4	22.5	11.6	27.0	16.1	11.84	28.2	6.9	11.99	23.9	21.2	11.79	25.4	15.2	12.05	26.6	6.5	12.3	21.2	18.7	13.12	22.5	13.4	13.48	23.5	5.8	13.73
	26.7	25.9	24.9	11.63	27.5	20.2	11.87	28.8	13.1	12.02	24.4	23.5	11.82	25.9	19.0	12.08	27.1	12.3	12.33	21.6	20.8	13.15	22.9	16.8	13.51	24.0	10.9	13.76
	29.4	26.4	26.4	11.66	28.1	24.4	11.9	29.4	18.6	12.05	24.9	24.9	11.85	26.4	23.0	12.11	27.6	17.5	12.36	22.0	22.0	13.18	23.4	20.3	13.54	24.5	15.5	13.79
	32.2	27.0	27.0	11.69	28.6	27.5	11.93	30.0	23.2	12.08	25.4	25.4	11.88	27.0	25.9	12.14	28.2	21.9	12.39	22.5	22.5	13.22	23.8	22.9	13.58	25.0	19.4	13.83

Notes:

1. DB = Dry Bulb Temperature (°C), WB = Wet Bulb Temperature (°C)
4. TGC = Total Cooling Capacity (kW)
5. SHC = Sensible Heating Capacity (kW)
6. PI = Power Input (kW)

**7.3 120 kBtu/h**

Gross Cooling Capacity (kW)																			
Outdoor DB(°C)		29.40									35.00								
Indoor	WB(°C)	16.10			19.40			22.80			16.10			19.40			22.80		
CFM	DB(°C)	TGC	SHC	PI	TGC	SHC	PI	TGC	SHC	PI	TGC	SHC	PI	TGC	SHC	PI	TGC	SHC	PI
3300	23.9	30.8	24.1	11.97	33.4	18.9	12.17	34.8	8.0	12.3	30.2	24.8	12.4	32.2	18.2	12.63	33.5	7.7	12.77
	26.7	31.9	27.5	12	34.1	22.1	12.2	35.5	15.3	12.33	30.8	28.0	12.43	32.9	21.3	12.66	34.2	14.7	12.8
	29.4	33.0	30.0	12.03	34.8	28.5	12.23	36.2	21.5	12.36	31.4	30.2	12.46	33.5	27.5	12.69	34.9	20.8	12.83
	32.2	34.2	33.5	12.06	35.5	32.2	12.26	36.9	27.1	12.39	32.0	31.4	12.49	34.2	31.1	12.72	35.6	26.2	12.86
3700	23.9	31.9	25.5	12.17	34.0	19.7	12.37	35.4	8.4	12.5	31.2	26.2	12.6	32.8	19.0	12.83	34.1	8.1	12.97
	26.7	33.0	28.7	12.2	34.7	24.6	12.4	36.1	15.8	12.53	31.8	29.4	12.63	33.5	23.8	12.86	34.8	15.3	13
	29.4	34.2	31.6	12.23	35.4	29.7	12.43	36.8	22.5	12.56	32.4	31.8	12.66	34.2	28.7	12.89	35.5	21.6	13.03
	32.2	35.4	33.7	12.26	36.1	33.4	12.46	37.6	28.0	12.59	33.1	33.1	12.69	34.9	32.3	12.92	36.2	27.0	13.07
4000	23.9	32.4	28.2	12.41	34.5	21.6	12.74	35.9	9.3	12.74	31.7	29.1	12.84	33.3	20.8	13.07	34.6	9.0	13.21
	26.7	33.5	31.9	12.44	35.2	27.1	12.64	36.6	17.5	12.77	32.3	32.3	12.87	34.0	26.2	13.1	35.3	16.9	13.24
	29.4	34.7	33.7	12.47	35.9	32.9	12.67	37.3	24.7	12.8	33.0	33.0	12.9	34.7	31.8	13.13	36.0	23.9	13.27
	32.2	35.9	35.2	12.5	36.6	33.3	12.7	38.1	31.0	12.83	33.6	33.6	12.93	35.4	32.2	13.17	36.7	29.9	13.31
4500	23.9	32.9	29.1	12.72	35.0	21.0	12.92	36.4	8.9	13.05	32.5	28.7	13.15	33.8	20.3	13.38	35.1	8.6	13.52
	26.7	34.0	32.7	12.75	35.7	26.3	12.95	37.1	16.9	13.08	33.1	31.8	13.18	34.5	25.4	13.41	35.8	16.3	13.55
	29.4	35.2	34.2	12.78	36.4	31.7	12.98	37.8	24.0	13.11	33.8	33.8	13.21	35.2	30.6	13.44	36.5	23.1	13.58
	32.2	36.4	35.7	12.81	37.1	35.7	13.01	38.6	29.9	13.15	34.4	34.4	13.25	35.9	34.5	13.48	37.3	28.9	13.62

Gross Cooling Capacity (kW)																												
Outdoor DB(°C)		40.60									46.10									51.70								
Indoor	WB(°C)	16.10			19.40			22.80			16.10			19.40			22.80			16.10			19.40			22.80		
CFM	DB(°C)	TGC	SHC	PI	TGC	SHC	PI	TGC	SHC	PI	TGC	SHC	PI	TGC	SHC	PI	TGC	SHC	PI	TGC	SHC	PI	TGC	SHC	PI	TGC	SHC	PI
3300	23.9	29.8	24.4	14.37	31.4	17.7	14.61	32.6	7.5	14.76	28.3	23.2	14.56	29.8	16.8	14.82	31.0	7.2	15.07	29.5	24.2	16.36	30.8	17.4	16.72	31.8	7.4	16.97
	26.7	30.4	27.6	14.41	32.0	20.7	14.65	33.3	14.3	14.8	28.9	26.3	14.6	30.4	19.7	14.86	31.6	13.6	15.11	30.1	27.4	16.4	31.4	20.3	16.76	32.5	14.0	17.01
	29.4	31.0	29.8	14.45	32.6	26.7	14.69	34.0	20.2	14.84	29.5	28.3	14.64	31.0	25.4	14.9	32.2	19.2	15.15	30.7	29.5	16.44	32.0	26.2	16.8	33.1	19.7	17.05
	32.2	31.6	31.0	14.48	33.3	30.3	14.72	34.6	25.5	14.87	30.1	29.5	14.67	31.6	28.7	14.93	32.9	24.2	15.19	31.3	30.7	16.48	32.7	29.7	16.84	33.8	24.9	17.1
3700	23.9	30.4	25.5	14.57	32.0	18.5	14.81	33.2	7.8	14.96	28.9	24.3	14.76	30.4	17.6	15.02	31.6	7.5	15.27	30.1	25.3	16.56	31.4	18.1	16.92	32.5	7.7	17.17
	26.7	31.0	28.7	14.61	32.6	23.1	14.85	33.9	14.9	15	29.5	27.3	14.8	31.0	22.0	15.06	32.2	14.1	15.31	30.7	28.4	16.6	32.0	22.7	16.96	33.1	14.5	17.21
	29.4	31.6	31.0	14.65	33.3	27.9	14.89	34.6	21.1	15.04	30.1	29.5	14.84	31.6	26.6	15.1	32.8	20.0	15.35	31.3	30.7	16.64	32.6	27.4	17	33.8	20.6	17.25
	32.2	32.3	32.3	14.68	33.9	31.4	14.92	35.3	26.3	15.08	30.7	30.7	14.87	32.3	29.9	15.14	33.5	25.0	15.39	31.9	31.9	16.68	33.3	30.8	17.04	34.4	25.7	17.3
4000	23.9	30.9	28.3	14.27	32.5	20.3	14.66	33.7	8.7	14.66	29.4	27.0	15	30.9	19.3	15.26	32.1	8.3	15.51	30.6	28.1	16.8	31.9	19.9	17.16	32.9	8.5	17.41
	26.7	31.5	31.5	14.31	33.1	25.5	14.55	34.4	16.5	14.7	30.0	30.0	15.04	31.5	24.2	15.3	32.7	15.7	15.55	31.2	31.2	16.84	32.5	25.0	17.2	33.6	16.1	17.45
	29.4	32.1	32.1	14.35	33.8	31.0	14.59	35.1	23.2	14.74	30.6	30.6	15.08	32.1	29.5	15.34	33.4	22.1	15.59	31.8	31.8	16.88	33.2	30.4	17.24	34.3	22.7	17.49
	32.2	32.8	32.8	14.38	34.4	31.3	14.62	35.8	29.1	14.77	31.2	31.2	15.12	32.8	29.8	15.38	34.0	27.7	15.63	32.5	32.5	16.92	33.8	30.7	17.29	35.0	28.4	17.54
4500	23.9	31.4	27.8	15.12	32.9	19.7	15.36	34.2	8.4	15.51	29.9	26.5	15.31	31.4	18.8	15.57	32.6	8.0	15.82	31.1	27.5	17.11	32.4	19.4	17.47	33.4	8.2	17.72
	26.7	32.0	30.8	15.16	33.6	24.7	15.4	34.9	15.9	15.55	30.5	29.3	15.35	32.0	23.5	15.61	33.2	15.1	15.86	31.7	30.5	17.15	33.0	24.3	17.51	34.1	15.5	17.76
	29.4	32.6	32.6	15.2	34.3	29.8	15.44	35.6	22.5	15.59	31.1	31.1	15.39	32.6	28.4	15.65	33.9	21.4	15.9	32.3	32.3	17.19	33.7	29.3	17.55	34.8	22.0	17.8
	32.2	33.3	33.3	15.24	35.0	33.6	15.48	36.3	28.2	15.63	31.7	31.7	15.43	33.3	32.0	15.69	34.5	26.8	15.94	33.0	33.0	17.24	34.3	33.0	17.6	35.5	27.5	17.85

Notes:

1. DB = Dry Bulb Temperature (°C), WB = Wet Bulb Temperature (°C)
4. TGC = Total Cooling Capacity (kW)
5. SHC = Sensible Heating Capacity (kW)
6. PI = Power Input (kW)

## 8. Air flow rate- Static pressure curve

### 8.1 76kBTu/h

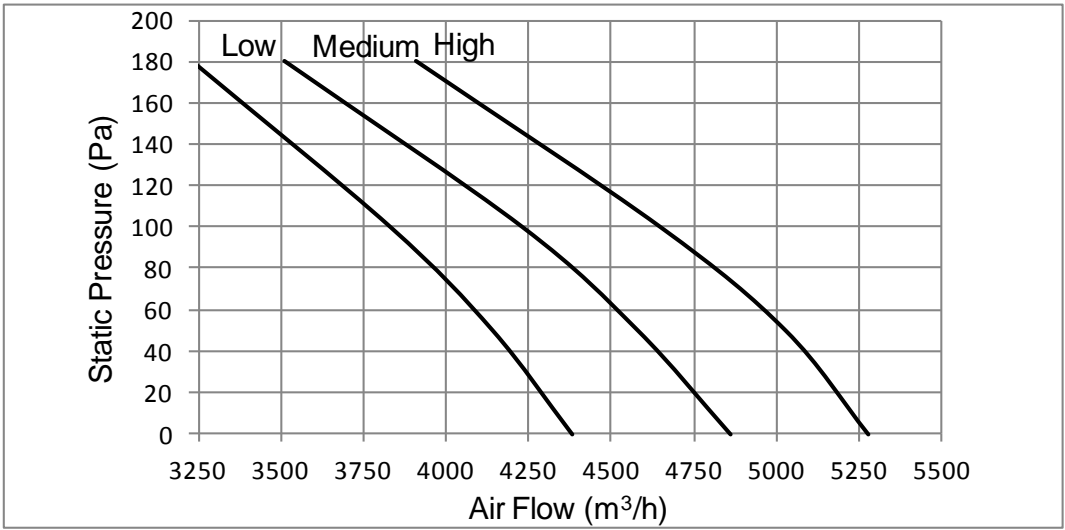

### 8.2 96kBTu/h

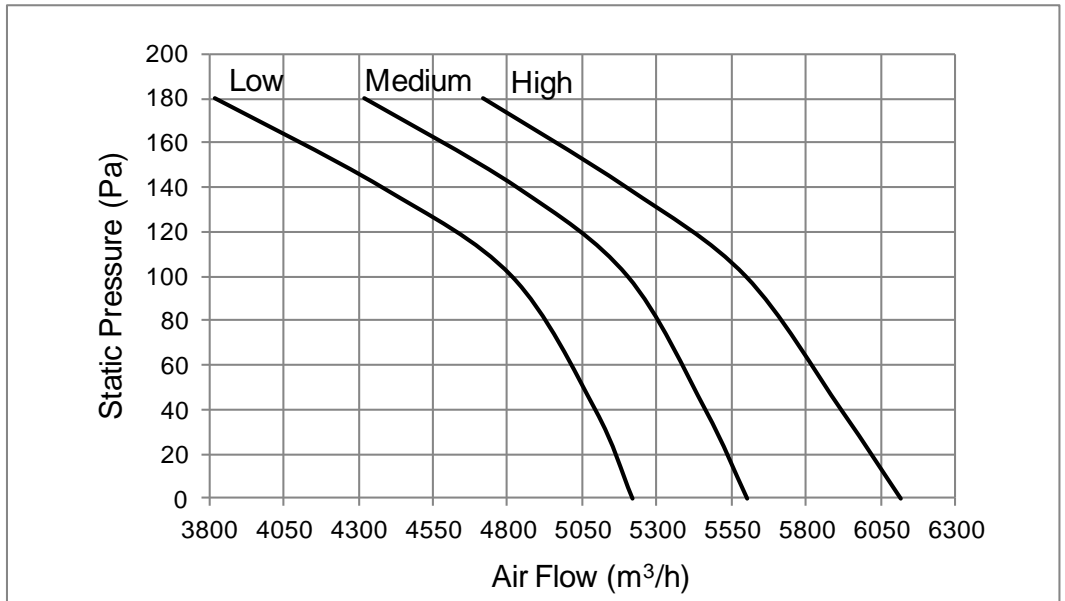

### 8.3 120kBTu/h

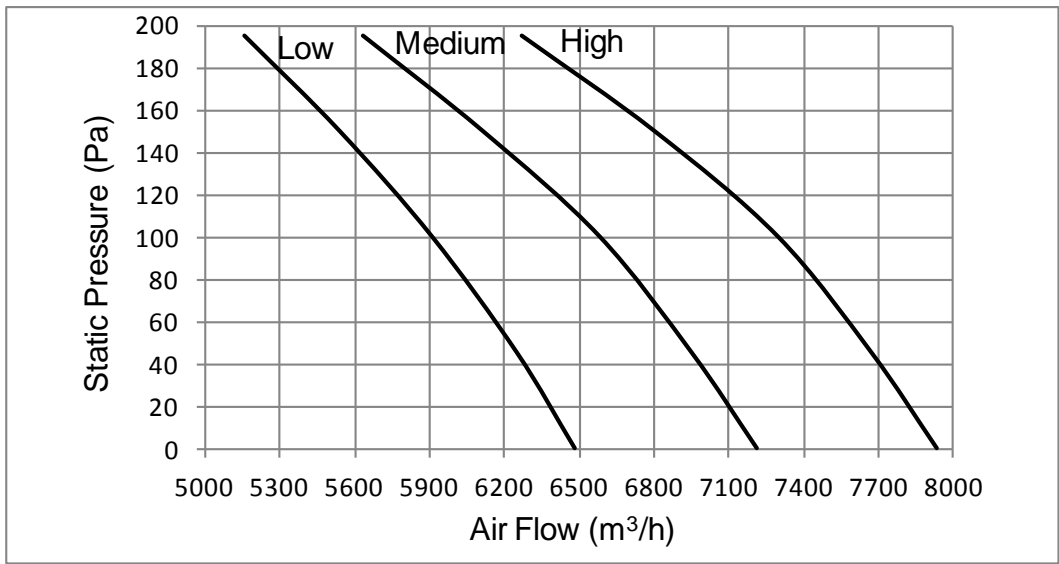



## 9. Electric Characteristics

Model	Indoor Unit				Power Supply		IFM	
	Hz	Voltage	Min.	Max.	MCA	MFA	kW	FLA
MDTA-76CRN2	50	220-240	198	254	10	8	1.42	6.66
MDTA-76HRN2	50	220-240	198	254	10	8	1.42	6.66
MDTA-96CRN2	50	220-240	198	254	10	12	1.8	8.6
MDTA-96HRN2	50	220-240	198	254	10	12	1.8	8.6
MDTA-120CRN2	50	220-240	198	254	11.25	20	2.1	10
MDTA-120HRN2	50	220-240	198	254	11.25	20	2.1	10

**Note:**

MCA: Min. Current Amps. (A)

MFA: Max. Fuse Amps. (A)

IFM: Indoor Fan Motor

kW: Fan Motor Rated Output (kW)

FLA: Full Load Amps. (A)

Model	Outdoor Unit				Power Supply			Compressor		OFM	
	Hz	Voltage	Min.	Max.	MCA	TOCA	MFA	MSC	RLA	KW	FLA
MDOV-76C-CN2	50	380-415	342	438	15.75	18.5	21.85	48*2	6.3*2	0.573	2.613
MDOV-76H-CN2	50	380-415	342	438	15.75	18.5	21.85	48*2	6.3*2	0.573	2.613
MDOV-96C-CN2	50	380-415	342	438	20	28	30	53*2	8.0*2	0.573	2.613
MDOV-96H-CN2	50	380-415	342	438	20	28	30	53*2	8.0*2	0.573	2.613
MDOV-120C-CN2	50	380-415	342	438	22.75	28.7	32.55	57*2	9.1*2	1.2	5.857
MDOV-120H-CN2	50	380-415	342	438	22.75	28.7	32.55	57*2	9.1*2	1.2	5.857

**Note:**

MCA: Min. Current Amps. (A)

MFA: Max. Fuse Amps. (A)

RLA: Rated Locked Amps. (A)

KW: Rated Motor Output (KW)

TOCA: Total Over-current Amps. (A)

MSC: Max. Starting Amps. (A)

OFM: Outdoor Fan Motor

FLA: Full Load Amps. (A)

## 10. Sound Levels

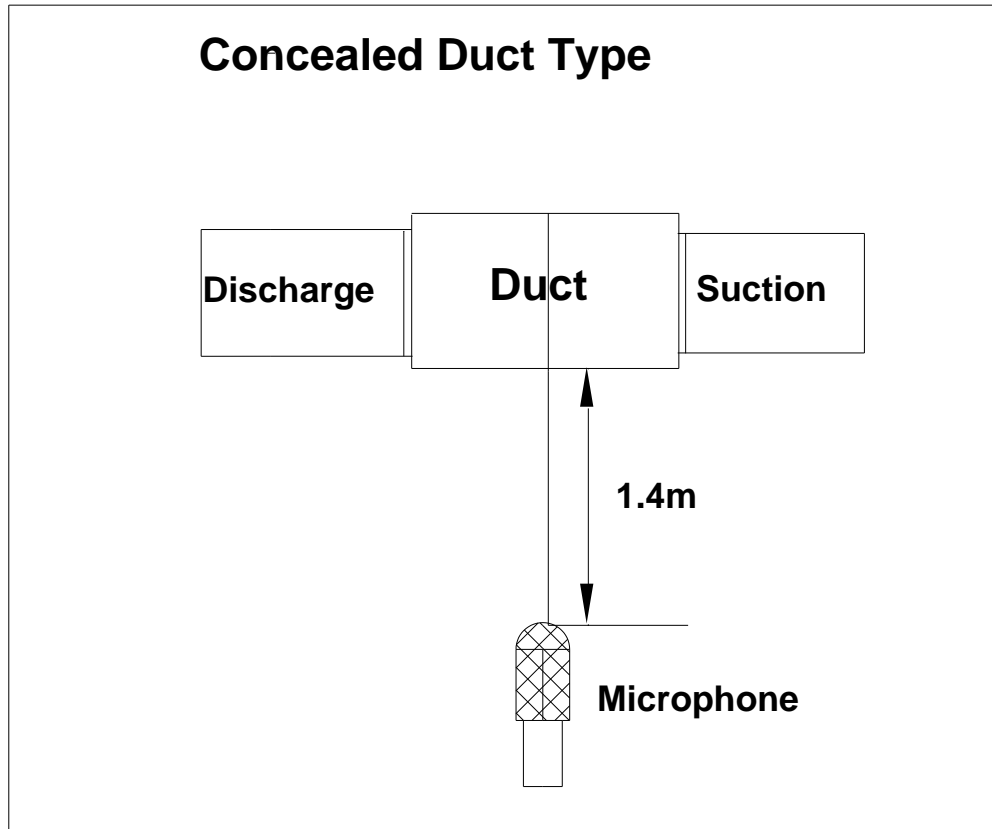

Unit Number	Model	Noise level under three speeds of fan (dB(A))
1	MDTA-76C(H)RN2	54
2	MDTA-96C(H)RN2	55
3	MDTA-120C(H)RN2	56

## 12. Troubleshooting

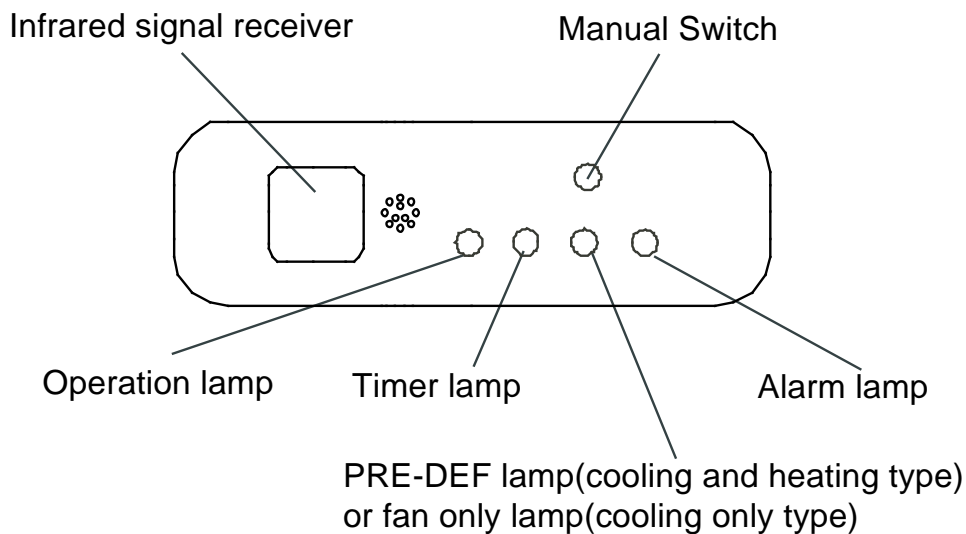

Type	OPT. Light	TME. Light	DEF. Light	ALARM Light	Remarks
Room temp. sensor error	-	☆	-	-	Manual reset
Evaporator temp. sensor error	☆	-	-	-	Manual reset
Condenser temp. sensor error	-	-	☆	-	Manual reset
Water pump temp. sensor error	☆	-	-	☆	Manual reset
The PRO terminal on PCB of indoor unit without connected to grounding wire	☆	☆	☆	☆	Manual reset
EEPROM error	☆	☆	-	-	Manual reset
Condensing water level full error	-	-	-	☆	Manual reset

Note:

OPT. Light: operation light;      TME. Light: timer light;  
DEF. Light: defrosting light;      ☆: the light flashing.

### 13.1 Malfunctions of air conditioner

If any of the following malfunctions occur, stop operation of the air conditioner immediately. Turn off the power switch, and contact the local after sales service center of manufacturer:

- The RUN lamp flashes quickly (2 flash per second).
- After turning off the power switch and then turning it on again, the RUN lamp still flashes quickly.
- The receiving function of the remote controller fails, or the start/ shutdown operation is abnormal.
- The fuse blows out frequently, or the circuit breaker protection occurs frequently.
- Obstacles or water enter the air conditioner.
- Condensing water leaks from indoor unit.
- Other malfunctions occur.

If the air conditioner fails and does not meet the above phenomena, check the system as the following table:

Symptoms	Causes	Handling methods
The unit does not work	Power supply fails.	Operate after power resumes.
	Power switch is not connected.	Connect the power supply properly.
	Fuse blows out or circuit breaker snaps off.	Replace the fuse or check whether electric leakage occurs.
	The remote controller or the wire controller fails.	Check the remote controller or wire controller.
Air flowing normally but completely can't cooling	Temperature setting is improper.	Temperature setting is higher than the room temperature in cooling mode. Or temperature setting is lower than the room temperature in heating mode.
	3-minute protection of compressor.	Waiting for 3 minutes.
The unit starts or stops frequently	The system is lack of refrigerant. Or there is too much refrigerant in the system.	Fix the leakage places, and charge the proper quantity of refrigerant.
	Air or non-condensable gas exists in the refrigerant system.	Vacuum the system and charge refrigerant again.
	Compressor fails.	Repair or replace the compressor.
	The voltage is too high or too low.	Install a voltage regulator.
	The refrigerant pipe is obstructed.	Locate and replace that part.
Poor cooling effect	The heat exchanger of outdoor unit or indoor unit is too dirty.	Clean the heat exchanger.
	The filter is too dirty.	Clean the filter.
	Air inlet or air outlet of the indoor/ outdoor unit is blocked.	Remove obstacles to keep well ventilating.
	Doors or windows of the room are open.	Close all the windows and doors.
	Directly exposed to sunlight.	Use curtain to obstruct sunlight.
	Too many heat sources in the room.	Reduce the heat sources.
	The outdoor ambient temperature is too high.	The cooling effect is poor but normal.
	The system is lack of refrigerant.	Fix the leakage places, and charge the proper quantity of refrigerant.
Poor heating effect	The outdoor ambient temperature is lower than -7°C	Use an assistance heating device.

	Doors or windows of the room are not closed tightly.	Close the doors and windows properly.
	The system is lack of refrigerant.	Fix the leakage places, and charge the proper quantity of refrigerant.

Symptoms	Causes	Handling methods
The fan speed cannot be changed	Check whether the mode marked on the screen is "AUTO".	When the "AUTO" mode is selected, the unit will change the fan speed automatically.
	Check whether the mode marked on the screen is "DEWET".	When the "DEWET" mode is selected, the unit will change the fan speed automatically. The fan speed can be selected in "COOLING", "HEATING" and "SUPPLY AIR" mode.
The "ON/OFF" button of remote controller do not work	Check whether the batteries of remote controller are exhausted.	Replace the batteries.
The "ON/OFF" lamp extinguishes	Check whether the time set on the timer has expired.	Restart the unit.
The "TIMER ON" lamp extinguishes	Check whether the time set on the timer has expired.	It comes to the setting time and the unit stat running automatically.
No receiving sounds from the indoor unit even when the "ON/OFF" button is pressed	Check whether the signal transmitter of the remote controller is properly directed to the infrared signal receiver of the indoor unit when the "ON/OFF" button is pressed.	Directly transmit the signal transmitter of the remote controller to the infrared signal receiver of the indoor unit, and then push the "ON/OFF" button twice.
The buttons of the remote controller do not work	Check whether the settings are locked.	Push the "LOCK" button again.

**Operation lamp flashes:**

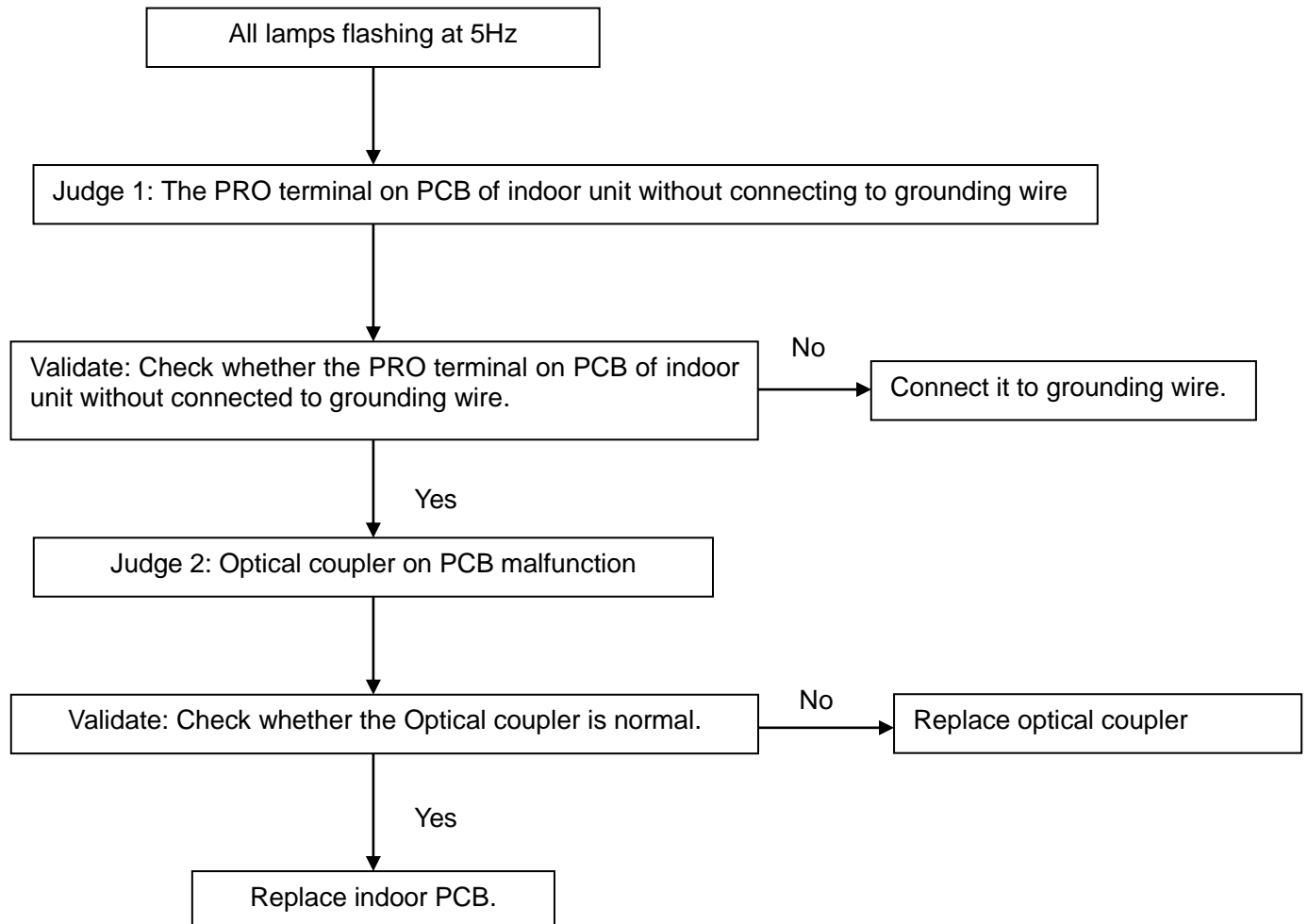

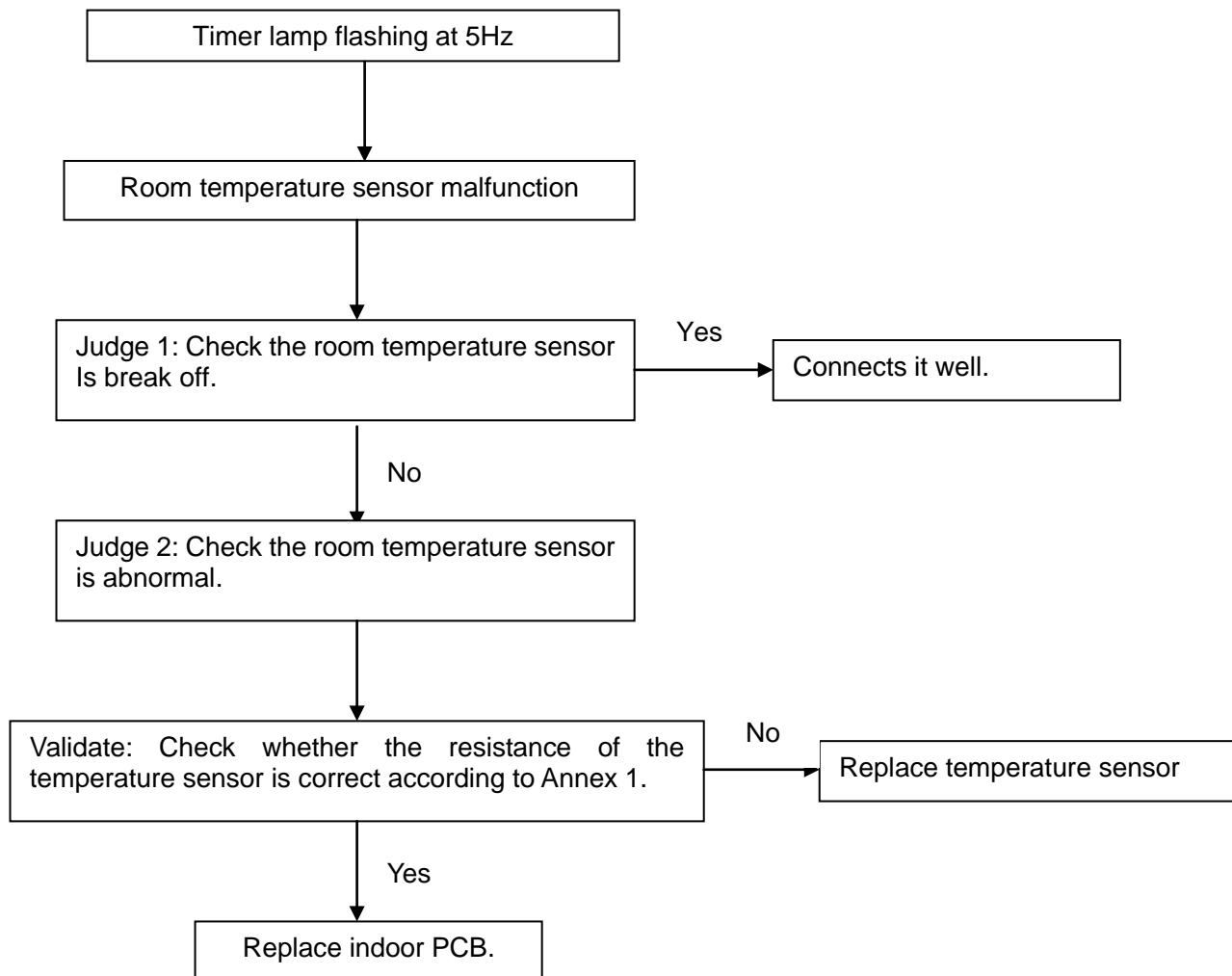
**Operation lamp flashes:**

**Operation lamp flashes:**

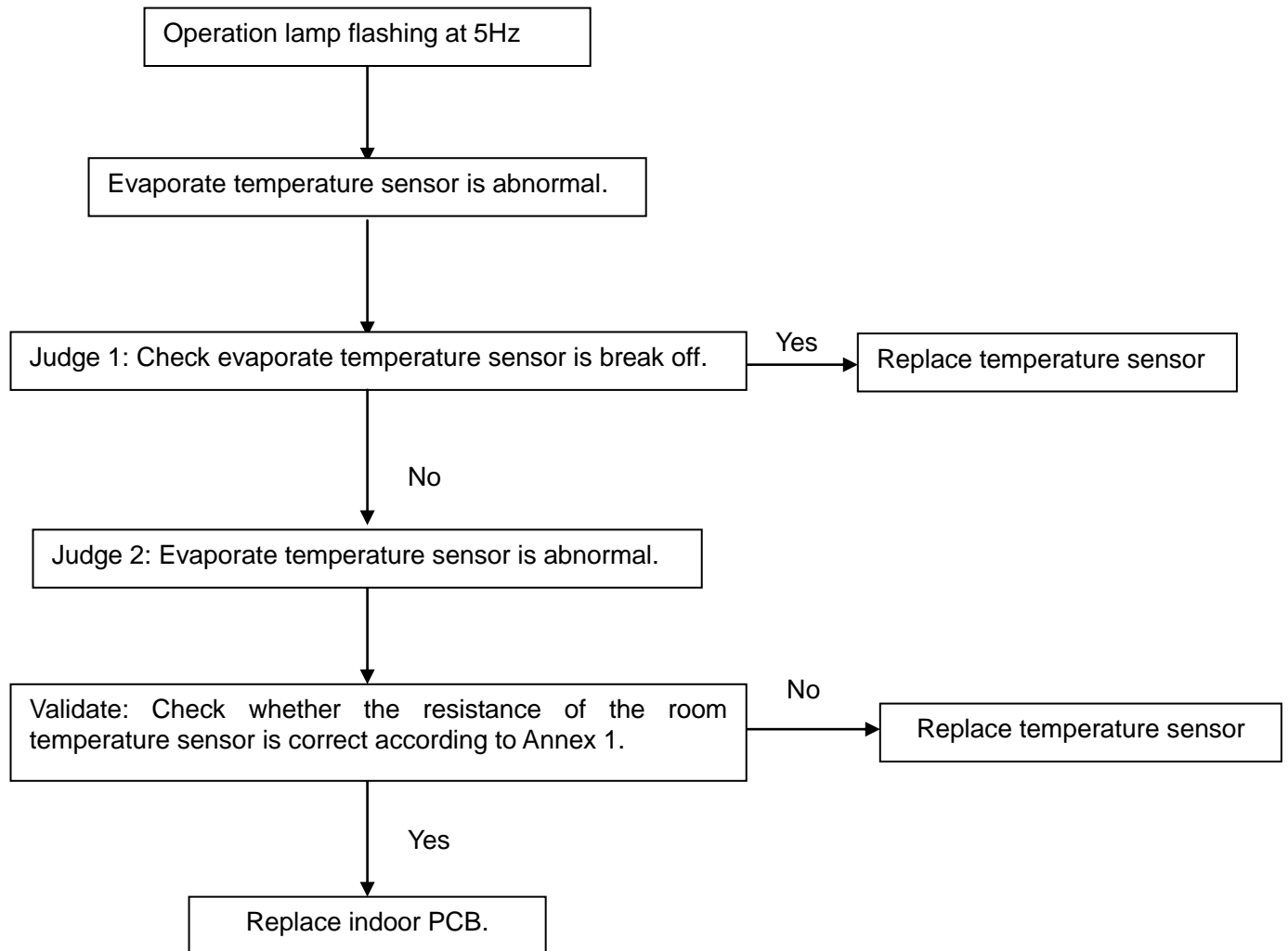

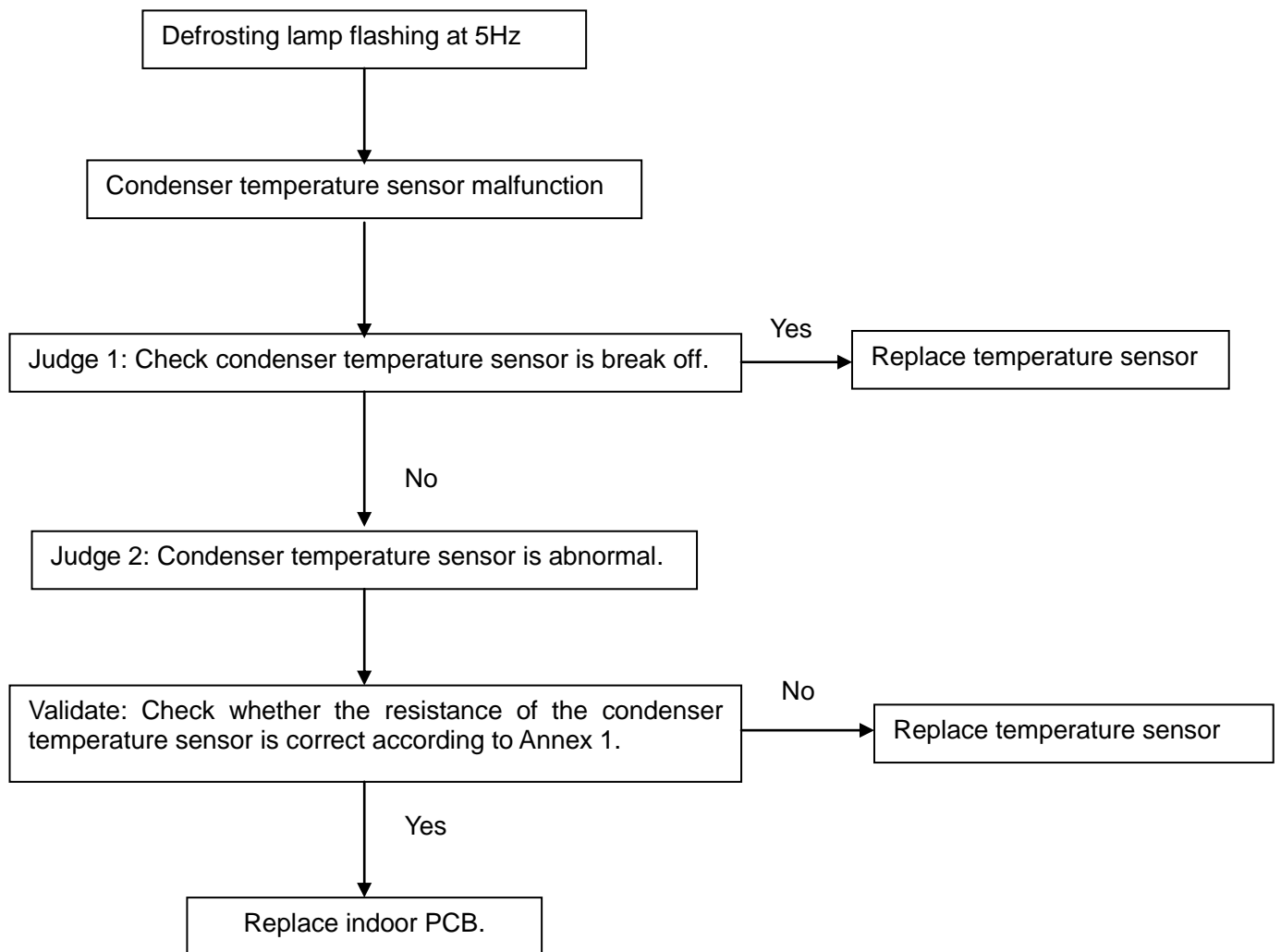

**Operation lamp flashes:**

## **Floor-standing Type**

<b>1. Features.....</b>	<b>32</b>
<b>2. Specifications .....</b>	<b>33</b>
<b>3. Dimensions .....</b>	<b>34</b>
<b>4. Service Space .....</b>	<b>35</b>
<b>5. Refrigerant cycle diagrams.....</b>	<b>36</b>
<b>6. Wiring Diagrams .....</b>	<b>37</b>
<b>7. Capacity Tables.....</b>	<b>39</b>
<b>8. Electric Characteristics .....</b>	<b>43</b>
<b>9. Sound Levels .....</b>	<b>44</b>
<b>10. Exploded View .....</b>	<b>Ошибка! Закладка не определена.</b>
<b>11. Troubleshooting.....</b>	<b>45</b>
<b>12. Accessories.....</b>	<b>Ошибка! Закладка не определена.</b>

## 1. Features



1. The appearance is novel, luxurious, refined.
2. High capacity of cooling/heating, efficient, and energy-saving.
3. Adopt advanced and high efficient scroll compressor, wide angle and long distance air supply.
4. Remote control standard, screen control optional.
5. Easy installation and maintenance.
6. Suit for hotel, meeting room, airport lounge, etc. public occasion use.

## 2. Specifications

Model			M DFA-76CRN2	M DFA-76HRN2	M DFA-96CRN2	M DFA-96HRN2
Code			220043900081	220043900071	220043900061	220043900051
Power supply		-	220~240V-1Ph-50Hz		220~240V-1Ph-50Hz	
Rated input power		W	11500	11500	14500	14700
Rated current		A	18.5	18.5	28	28.1
Cooling	Capacity	Btu/h	75,100	75,100	94,500	92,100
		W	22000	22000	27700	27000
	Input	W	7450	7450	9280	9450
	EER	W/W	2.95	2.95	2.98	2.86
Heating	Capacity	Btu/h	—	83600	—	103700
		W	—	24500	—	30400
	Input	W	—	6500	—	9130
	COP	W/W	—	3.77	—	3.33
Indoor air flow		m <sup>3</sup> /h	4500	4500	4500	4500
Indoor noise level		dB(A)	53	53	54	54
Refrigerant	Type	-	R407C	R407C	R407C	R407C
	Control	-	Capillary	Capillary	Capillary	Capillary
Fan	Type	-	Centrifugal fan	Centrifugal fan	Centrifugal fan	Centrifugal fan
	Fan model	-	YSK300-6	YSK300-6	YSK300-6	YSK300-6
	Dimension	mm	Φ250	Φ250	Φ250	Φ250
	Drive type/ Motor step	-	Direct/ Single	Direct/ Single	Direct/ Single	Direct/ Single
	Motor model	-	YSK300-6	YSK300-6	YSK300-6	YSK300-6
	Motor input* No.	W	590	590	590	590
	Motor speed(Hi)	rpm	870	870	870	870
Coil	Type	-	Copper tube and aluminum fin	Copper tube and aluminum fin	Copper tube and aluminum fin	Copper tube and aluminum fin
	Tube size	mm	Φ9.52	Φ9.52	Φ9.52	Φ9.52
	No. of rows	-	3	3	3	3
	Fin per inch	FPI	16	16	16	16
	Length* height	mm	982*711	982*711	982*711	982*711
Controller		-	Remote controller		Remote controller	
Drainage water pipe dia.		mm	Φ41	Φ41	Φ41	Φ41
Connection wiring	Power wiring	mm <sup>2</sup>	3×2.5	3×2.5	3×2.5	3×2.5
	Signal wiring	mm <sup>2</sup>	2×1.0	4×1.0	2×1.0	4×1.0
Indoor unit	Dimension (W×H×D)	mm	1200*1860*420	1200*1860*420	1200*1860*420	1200*1860*420
	Packing (W*H*D)	mm	1362*2023*582	1362*2023*582	1362*2023*582	1362*2023*582
	Net/Gross weight	kg	158/174	158/174	158/174	158/174

## Notes:

1. Nominal cooling capacities are based on the following conditions:

Indoor temp: 27°CDB, 19°CWB; Outdoor temp: 35°CDB; Equivalent ref. piping: 7.5m (horizontal)

2. Nominal heating capacities are based on the following conditions:

Indoor temp: 20°CDB; Outdoor temp: 7°CDB, 6°CWB; Equivalent ref. piping: 7.5m (horizontal)

### 3. Dimensions

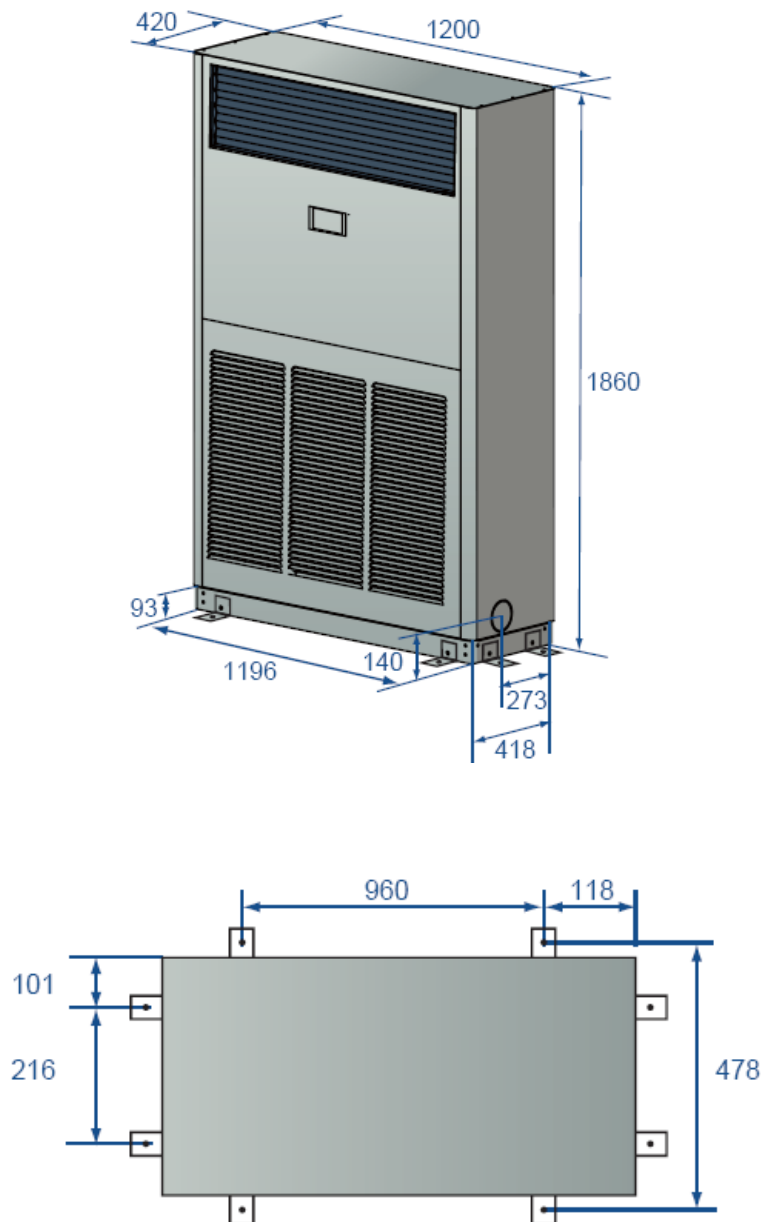

## 4. Service Space

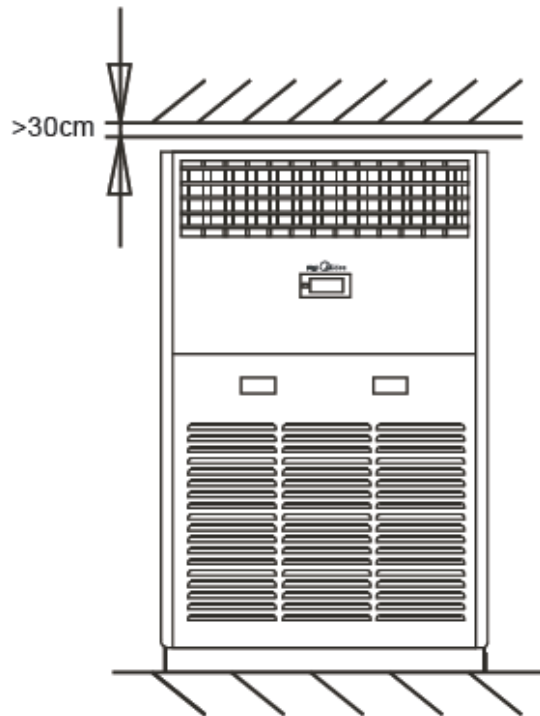

Front view

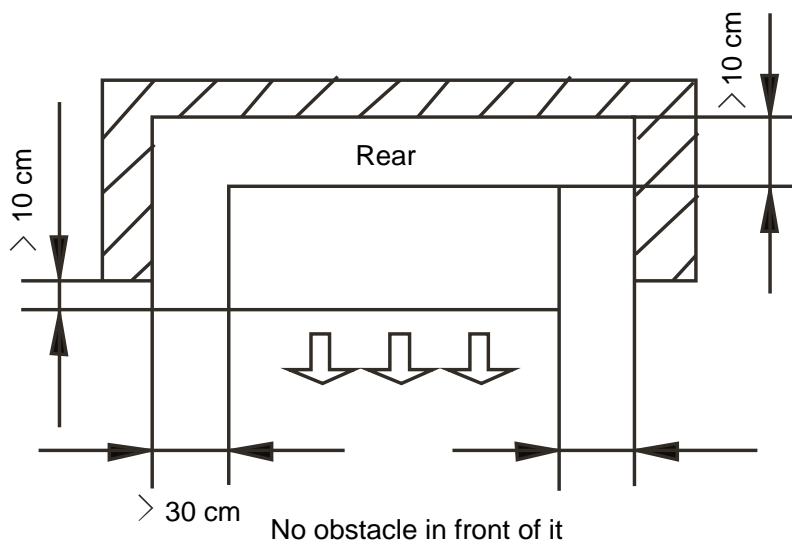

## 5. Refrigerant cycle diagrams

### 5.1 Cooling only: MDFA-76CRN2, MDFA-96CRN2

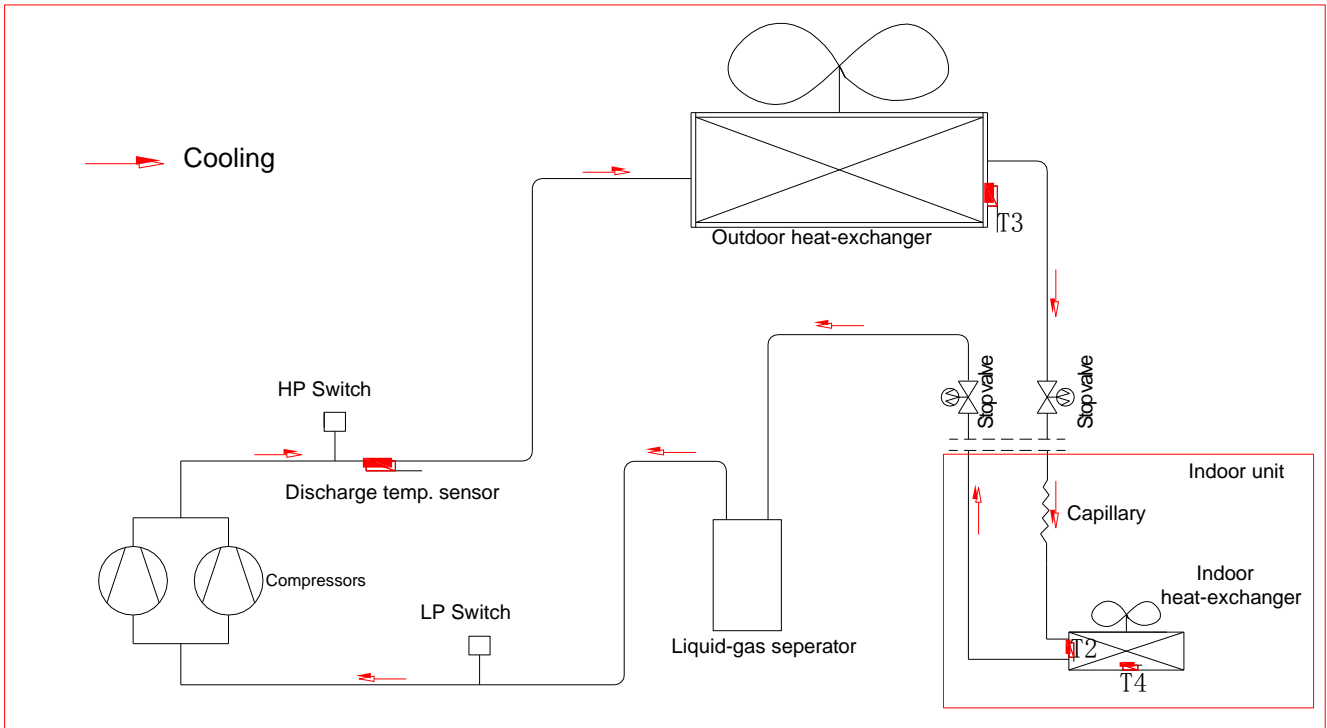

### 5.2 Cooling and heating: MDFA-76HRN2, MDFA-96HRN2

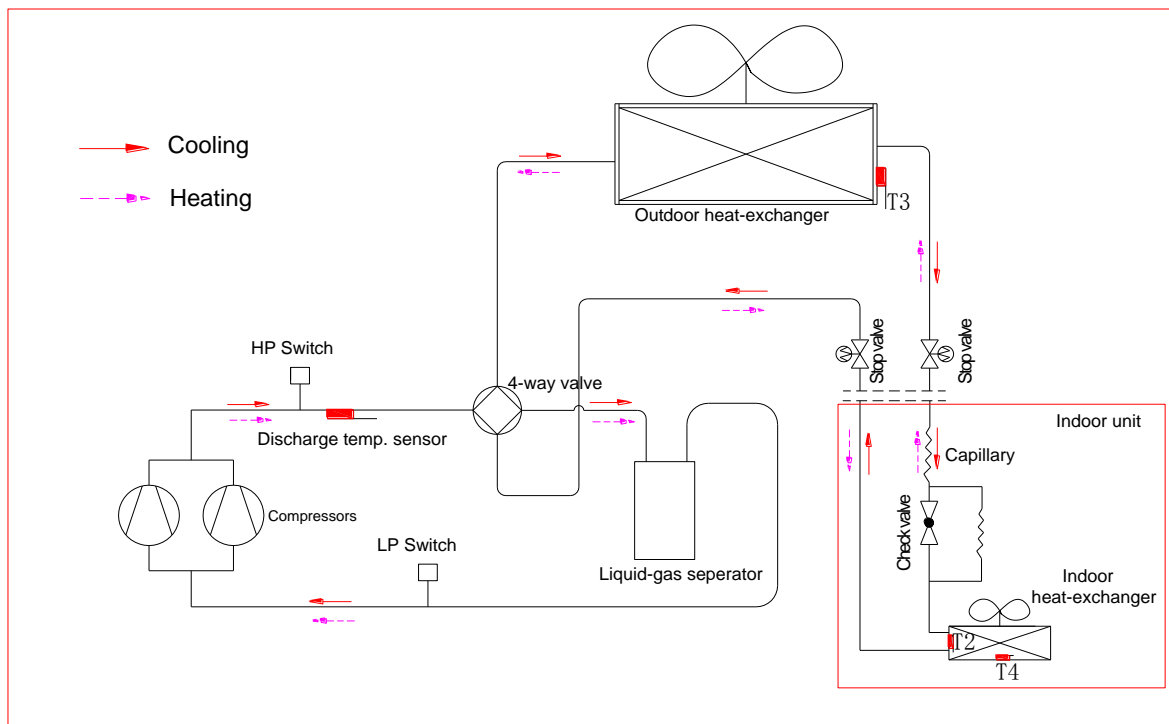

## 6. Wiring Diagrams

### 6.1 MDFA-76CRN2, MDFA-96CRN2

#### Wiring Diagram

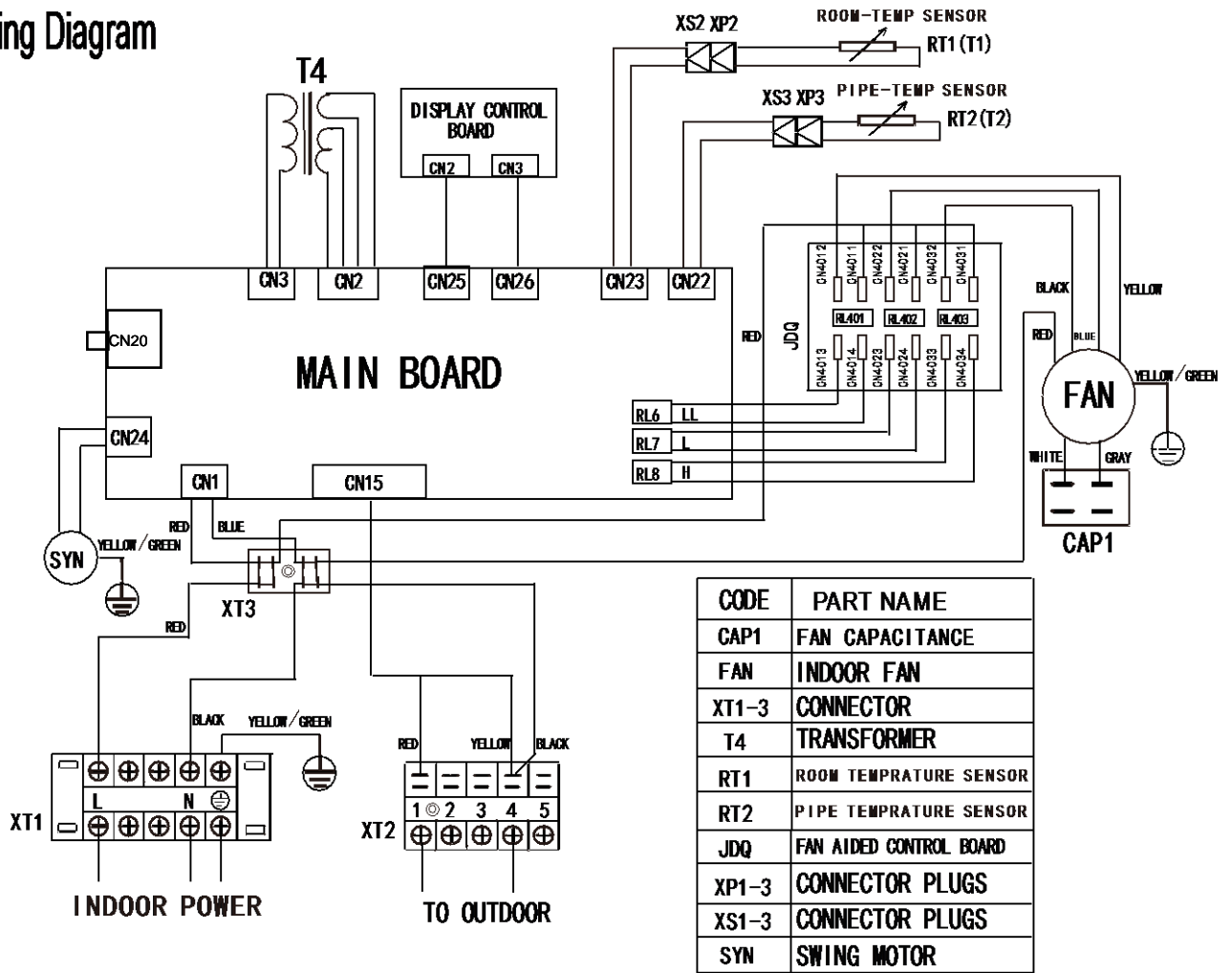



6.2 MDFA-76HRN2, MDFA-96HRN2

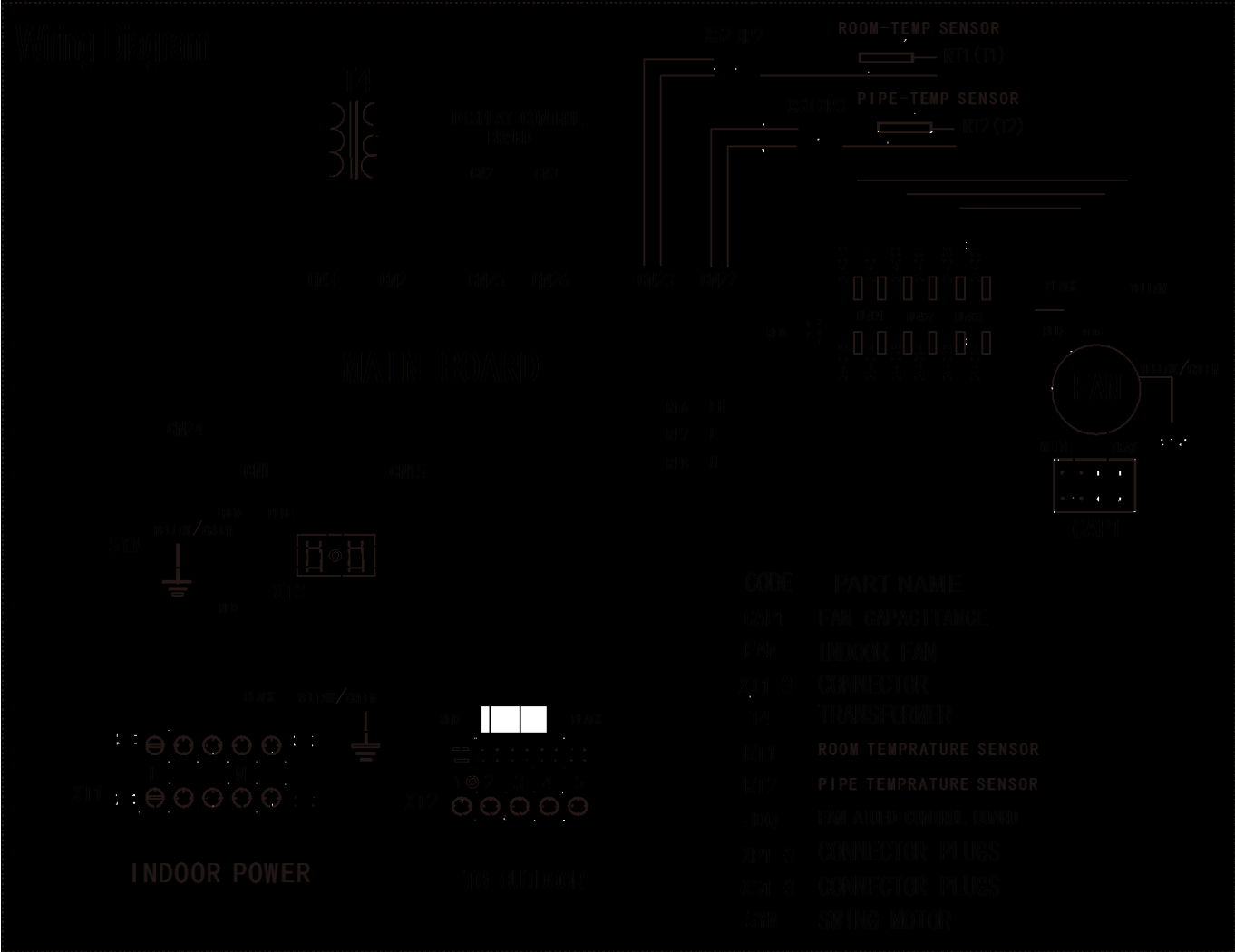

## 7. Capacity Tables

### 7.1 76kBtu/h

Gross Cooling Capacity (kW)																			
Outdoor DB(°C)		29.40									35.00								
Indoor	WB(°C)	16.10			19.40			22.80			16.10			19.40			22.80		
CFM	DB(°C)	TGC	SHC	PI	TGC	SHC	PI	TGC	SHC	PI	TGC	SHC	PI	TGC	SHC	PI	TGC	SHC	PI
2125	23.9	19.6	16.1	6.33	21.7	12.2	6.53	23.0	5.3	6.66	18.8	15.4	6.76	20.5	11.6	6.99	21.8	5.0	7.13
	26.7	20.3	18.4	6.35	22.1	14.3	6.55	23.5	10.1	6.68	19.2	17.4	6.78	20.9	13.5	7.01	22.2	9.6	7.15
	29.4	21.0	20.2	6.37	22.5	18.5	6.57	24.0	14.3	6.7	19.6	18.8	6.8	21.3	17.5	7.03	22.6	13.5	7.17
	32.2	21.7	21.3	6.38	23.0	20.9	6.58	24.4	18.0	6.71	20.0	19.6	6.81	21.7	19.8	7.05	23.1	17.0	7.19
2310	23.9	20.2	17.0	6.53	22.3	12.9	6.73	23.6	5.6	6.86	19.4	16.3	6.96	21.1	12.2	7.19	22.4	5.3	7.33
	26.7	20.9	19.4	6.55	22.7	16.1	6.75	24.1	10.6	6.88	19.8	18.3	6.98	21.5	15.3	7.21	22.8	10.0	7.35
	29.4	21.6	21.2	6.57	23.2	19.5	6.77	24.6	15.0	6.9	20.2	19.8	7	21.9	18.4	7.23	23.3	14.2	7.37
	32.2	22.4	22.4	6.58	23.6	21.9	6.78	25.1	18.7	6.91	20.6	20.6	7.01	22.4	20.7	7.25	23.7	17.7	7.39
2650	23.9	20.7	19.0	6.77	22.8	14.2	7.1	24.1	6.3	7.1	19.9	18.3	7.2	21.6	13.5	7.43	22.8	5.9	7.57
	26.7	21.4	21.4	6.79	23.2	17.9	6.99	24.6	11.8	7.12	20.3	20.3	7.22	22.0	16.9	7.45	23.3	11.2	7.59
	29.4	22.2	22.2	6.81	23.7	21.7	7.01	25.1	16.6	7.14	20.7	20.7	7.24	22.4	20.6	7.47	23.8	15.7	7.61
	32.2	22.9	22.9	6.82	24.1	21.9	7.02	25.6	20.8	7.16	21.1	21.1	7.26	22.9	20.8	7.49	24.2	19.7	7.63

Gross Cooling Capacity (kW)																												
Outdoor DB(°C)		40.60									46.10									51.70								
Indoor	WB(°C)	16.10			19.40			22.80			16.10			19.40			22.80			16.10			19.40			22.80		
CFM	DB(°C)	TGC	SHC	PI	TGC	SHC	PI	TGC	SHC	PI	TGC	SHC	PI	TGC	SHC	PI	TGC	SHC	PI	TGC	SHC	PI	TGC	SHC	PI	TGC	SHC	PI
2125	23.9	18.3	15.0	7.59	19.9	11.2	7.83	21.2	4.9	7.98	16.8	13.8	7.78	18.3	10.4	8.04	19.5	4.5	8.29	16.1	13.2	9.68	17.3	9.8	10.03	18.4	4.3	10.28
	26.7	18.7	17.0	7.61	20.3	13.1	7.85	21.6	9.3	8	17.2	15.6	7.8	18.7	12.1	8.06	19.9	8.6	8.31	16.4	14.9	9.7	17.7	11.5	10.06	18.8	8.1	10.31
	29.4	19.1	18.3	7.63	20.7	17.0	7.87	22.0	13.1	8.02	17.5	16.9	7.82	19.1	15.6	8.08	20.3	12.1	8.33	16.7	16.1	9.72	18.0	14.8	10.09	19.2	11.4	10.34
	32.2	19.4	19.1	7.65	21.1	19.2	7.89	22.5	16.5	8.04	17.9	17.5	7.84	19.4	17.7	8.1	20.7	15.2	8.35	17.0	16.7	9.75	18.4	16.7	10.11	19.5	14.4	10.36
2310	23.9	18.9	15.9	7.79	20.5	11.8	8.03	21.8	5.1	8.18	17.5	14.7	7.98	18.9	10.9	8.24	20.1	4.7	8.49	16.7	14.0	9.88	17.9	10.4	10.23	19.0	4.5	10.48
	26.7	19.3	17.9	7.81	20.9	14.8	8.05	22.2	9.7	8.2	17.8	16.5	8	19.3	13.7	8.26	20.5	9.0	8.51	17.0	15.7	9.9	18.3	13.0	10.26	19.4	8.5	10.51
	29.4	19.7	19.3	7.83	21.3	17.9	8.07	22.6	13.8	8.22	18.2	17.8	8.02	19.7	16.5	8.28	20.9	12.8	8.53	17.3	17.0	9.92	18.7	15.7	10.29	19.8	12.1	10.54
	32.2	20.1	20.1	7.85	21.7	20.1	8.09	23.1	17.2	8.24	18.5	18.5	8.04	20.1	18.6	8.3	21.3	15.9	8.55	17.7	17.7	9.95	19.0	17.6	10.31	20.2	15.1	10.56
2650	23.9	19.4	17.8	7.49	21.0	13.1	7.88	22.3	5.8	7.88	17.9	16.5	8.22	19.4	12.1	8.48	20.6	5.3	8.73	17.2	15.7	10.11	18.4	11.5	10.47	19.5	5.1	10.72
	26.7	19.8	19.8	7.51	21.4	16.5	7.75	22.7	10.9	7.9	18.3	18.3	8.24	19.8	15.2	8.5	21.0	10.1	8.75	17.5	17.5	10.14	18.8	14.5	10.5	19.9	9.5	10.75
	29.4	20.2	20.2	7.53	21.8	20.0	7.77	23.2	15.3	7.92	18.7	18.7	8.26	20.2	18.5	8.52	21.4	14.2	8.77	17.9	17.9	10.17	19.2	17.6	10.53	20.3	13.4	10.78
	32.2	20.6	20.6	7.55	22.3	20.2	7.79	23.6	19.2	7.94	19.0	19.0	8.28	20.6	18.7	8.54	21.9	17.8	8.79	18.2	18.2	10.19	19.6	17.8	10.55	20.7	16.8	10.8

- Notes:
1. DB = Dry Bulb Temperature (°C), WB = Wet Bulb Temperature (°C)
  4. TGC = Total Cooling Capacity (kW)
  5. SHC = Sensible Heating Capacity (kW)
  6. PI = Power Input (kW)

**7.2 96kBtu/h**

Gross Cooling Capacity (kW)																			
Outdoor DB(°C)		29.40									35.00								
Indoor	WB(°C)	16.10			19.40			22.80			16.10			19.40			22.80		
CFM	DB(°C)	TGC	SHC	PI	TGC	SHC	PI	TGC	SHC	PI	TGC	SHC	PI	TGC	SHC	PI	TGC	SHC	PI
2125	23.9	25.1	20.6	8.23	27.2	15.4	8.43	28.6	6.6	8.56	24.4	20.0	8.66	26.1	14.7	8.89	27.3	6.3	9.03
	26.7	26.0	23.6	8.25	27.8	18.0	8.45	29.2	12.6	8.58	24.9	22.6	8.68	26.6	17.2	8.91	27.9	12.0	9.05
	29.4	26.9	25.9	8.27	28.3	23.2	8.47	29.8	17.7	8.6	25.4	24.4	8.7	27.1	22.2	8.93	28.4	16.9	9.07
	32.2	27.8	27.3	8.29	28.9	26.3	8.49	30.4	22.3	8.62	25.9	25.4	8.72	27.7	25.1	8.95	29.0	21.3	9.1
2310	23.9	25.7	21.6	8.43	27.8	16.1	8.63	29.2	6.9	8.76	25.0	21.0	8.86	26.7	15.4	9.09	27.9	6.6	9.23
	26.7	26.6	24.6	8.45	28.4	20.1	8.65	29.8	13.1	8.78	25.5	23.6	8.88	27.2	19.3	9.11	28.5	12.5	9.25
	29.4	27.5	27.0	8.47	29.0	24.3	8.67	30.4	18.5	8.8	26.0	25.5	8.9	27.7	23.3	9.13	29.1	17.7	9.27
	32.2	28.5	28.5	8.49	29.6	27.4	8.69	31.0	23.1	8.82	26.5	26.5	8.92	28.3	26.2	9.16	29.7	22.1	9.3
2650	23.9	26.2	24.0	8.67	28.3	17.7	9	29.7	7.7	9	25.5	23.4	9.1	27.2	17.0	9.33	28.4	7.4	9.47
	26.7	27.1	27.1	8.69	28.9	22.2	8.89	30.3	14.5	9.02	26.0	26.0	9.12	27.7	21.3	9.35	29.0	13.9	9.49
	29.4	28.1	28.1	8.71	29.5	27.0	8.91	30.9	20.5	9.04	26.5	26.5	9.14	28.3	25.9	9.37	29.6	19.6	9.51
	32.2	29.0	29.0	8.73	30.1	27.3	8.93	31.5	25.6	9.07	27.1	27.1	9.17	28.8	26.2	9.4	30.2	24.5	9.54

Gross Cooling Capacity (kW)																												
Outdoor DB(°C)		40.60									46.10									51.70								
Indoor	WB(°C)	16.10			19.40			22.80			16.10			19.40			22.80			16.10			19.40			22.80		
CFM	DB(°C)	TGC	SHC	PI	TGC	SHC	PI	TGC	SHC	PI	TGC	SHC	PI	TGC	SHC	PI	TGC	SHC	PI	TGC	SHC	PI	TGC	SHC	PI	TGC	SHC	PI
2125	23.9	24.0	19.7	9.49	25.6	14.5	9.73	26.8	6.2	9.88	22.5	18.5	9.68	24.0	13.6	9.94	25.2	5.8	10.18	20.2	16.5	11.67	21.5	12.1	12.03	22.5	5.2	12.28
	26.7	24.5	22.3	9.51	26.1	16.9	9.75	27.4	11.8	9.9	23.0	20.9	9.7	24.5	15.9	9.96	25.7	11.1	10.21	20.6	18.7	11.7	21.9	14.2	12.06	23.0	9.9	12.31
	29.4	25.0	24.0	9.53	26.6	21.8	9.77	27.9	16.6	9.92	23.4	22.5	9.72	25.0	20.5	9.98	26.2	15.6	10.24	21.0	20.2	11.73	22.3	18.3	12.09	23.4	14.0	12.34
	32.2	25.5	25.0	9.56	27.1	24.7	9.8	28.5	21.0	9.95	23.9	23.4	9.75	25.5	23.2	10.01	26.7	19.7	10.26	21.4	21.0	11.76	22.8	20.7	12.12	23.9	17.6	12.37
2310	23.9	24.6	20.7	9.69	26.2	15.1	9.93	27.5	6.5	10.07	23.1	19.4	9.88	24.6	14.2	10.13	25.8	6.1	10.38	20.8	17.5	11.87	22.1	12.8	12.23	23.1	5.5	12.48
	26.7	25.1	23.2	9.71	26.7	18.9	9.95	28.0	12.3	10.1	23.6	21.9	9.9	25.1	17.8	10.16	26.3	11.5	10.41	21.2	19.6	11.9	22.5	16.0	12.26	23.6	10.4	12.51
	29.4	25.6	25.1	9.73	27.2	22.9	9.97	28.6	17.4	10.13	24.1	23.6	9.92	25.6	21.5	10.19	26.8	16.4	10.44	21.6	21.2	11.93	23.0	19.3	12.29	24.1	14.7	12.54
	32.2	26.1	26.1	9.76	27.8	25.7	10	29.1	21.7	10.15	24.6	24.6	9.95	26.1	24.2	10.21	27.4	20.4	10.46	22.1	22.1	11.96	23.4	21.7	12.32	24.6	18.3	12.57
2650	23.9	25.1	23.0	9.93	26.7	16.7	10.31	27.9	7.2	10.31	23.6	21.7	10.11	25.1	15.7	10.37	26.3	6.8	10.62	21.3	19.5	12.11	22.6	14.1	12.47	23.6	6.1	12.72
	26.7	25.6	25.6	9.95	27.2	20.9	10.19	28.5	13.6	10.34	24.1	24.1	10.14	25.6	19.7	10.4	26.8	12.8	10.65	21.7	21.7	12.14	23.0	17.7	12.5	24.1	11.5	12.75
	29.4	26.1	26.1	9.97	27.7	25.5	10.22	29.1	19.3	10.37	24.6	24.6	10.17	26.1	24.0	10.43	27.3	18.1	10.68	22.1	22.1	12.17	23.5	21.5	12.53	24.6	16.3	12.78
	32.2	26.6	26.6	10	28.3	25.7	10.24	29.7	24.1	10.39	25.1	25.1	10.19	26.6	24.2	10.45	27.9	22.7	10.7	22.6	22.6	12.2	23.9	21.8	12.56	25.1	20.4	12.81

Notes:

1. DB = Dry Bulb Temperature (°C), WB = Wet Bulb Temperature (°C)
4. TGC = Total Cooling Capacity (kW)
5. SHC = Sensible Heating Capacity (kW)
6. PI = Power Input (kW)

## 8. Electric Characteristics

Model	Indoor Unit				Power Supply		IFM	
	Hz	Voltage	Min.	Max.	MCA	MFA	KW	FLA
MDFA-76CRN2	50	220-240	198	254	3.25	8	0.59	2.773
MDFA-76HRN2	50	220-240	198	254	3.25	8	0.59	2.773
MDFA-96CRN2	50	220-240	198	254	3.25	12	0.59	2.773
MDFA-96HRN2	50	220-240	198	254	3.25	12	0.59	2.773

Note :

MCA: Min. Current Amps. (A)

MFA: Max. Fuse Amps. (A)

KW: Fan Motor Rated Output (KW)

FLA: Full Load Amps. (A)

IFM: Indoor Fan Motor

Model	Outdoor Unit				Power Supply			Compressor		OFM	
	Hz	Voltage	Min.	Max.	MCA	TOCA	MFA	MSC	RLA	KW	FLA
MDOV-76C-CN2	50	380-415	342	438	15.75	18.5	21.85	48*2	6.3*2	0.573	2.613
MDOV-76H-CN2	50	380-415	342	438	15.75	18.5	21.85	48*2	6.3*2	0.573	2.613
MDOV-96C-CN2	50	380-415	342	438	20	28	30	53*2	8.0*2	0.573	2.613
MDOV-96H-CN2	50	380-415	342	438	20	28	30	53*2	8.0*2	0.573	2.613

Note:

MCA: Min. Current Amps. (A)

MFA: Max. Fuse Amps. (A)

RLA: Rated Locked Amps. (A)

KW: Rated Motor Output (KW)

TOCA: Total Over-current Amps. (A)

MSC: Max. Starting Amps. (A)

OFM: Outdoor Fan Motor

FLA: Full Load Amps. (A)

## 9. Sound Levels

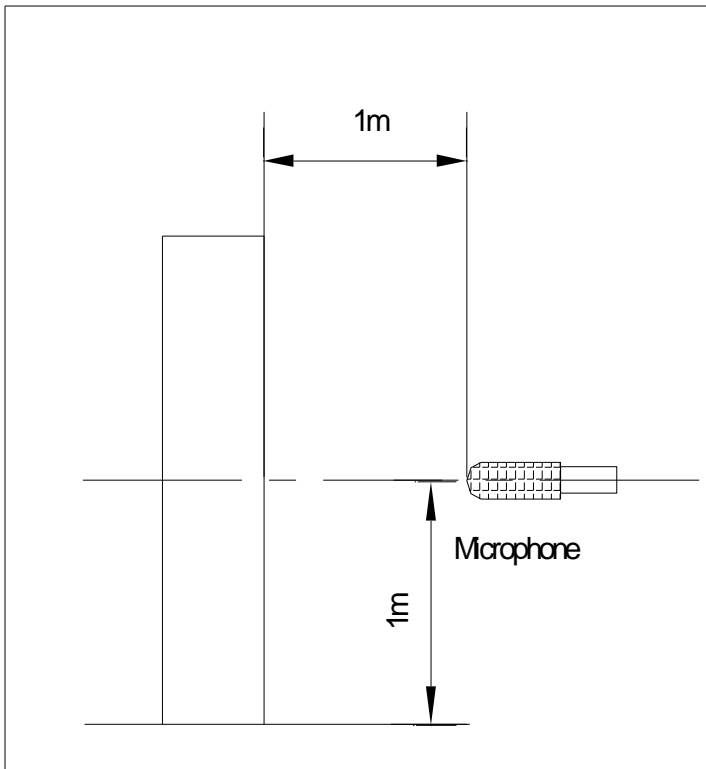

Unit Number	Model	Noise level under three speeds of fan (dB(A))
1	MFA-76C(H)R	53
2	MFA-96(H)R	54

## 11. Troubleshooting



Type	Code	Remarks
EEPROM error	E0	Manual reset
Room temp. sensor error	E1	Manual reset
Evaporator temp. sensor error	E2	Manual reset
Evaporator temp. too low protection in cooling mode	P1	Auto reset
Evaporator temp. too high protection in heating mode	P2	Auto reset

## 11.1 E1 malfunction

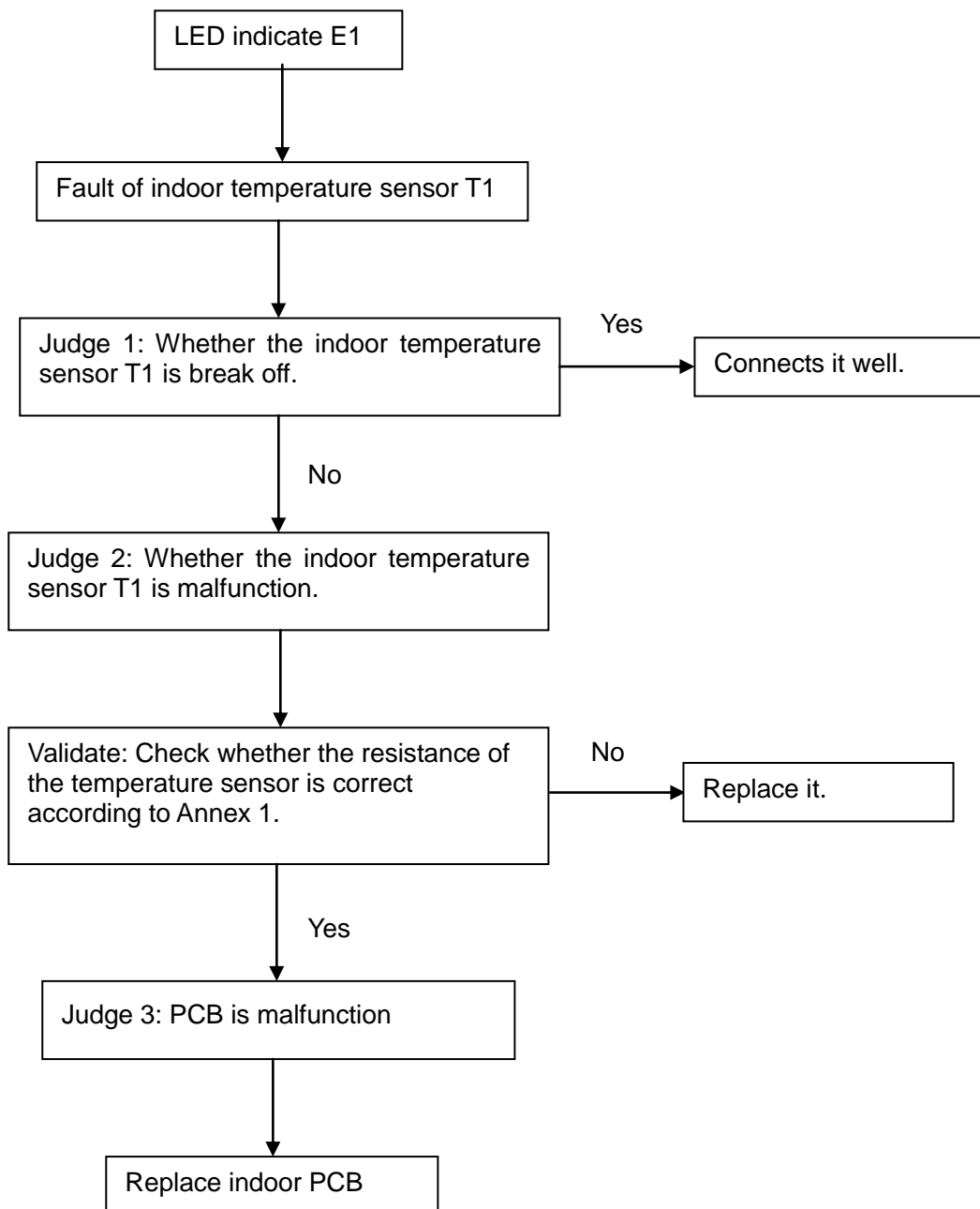



### 11.2 E2 malfunction

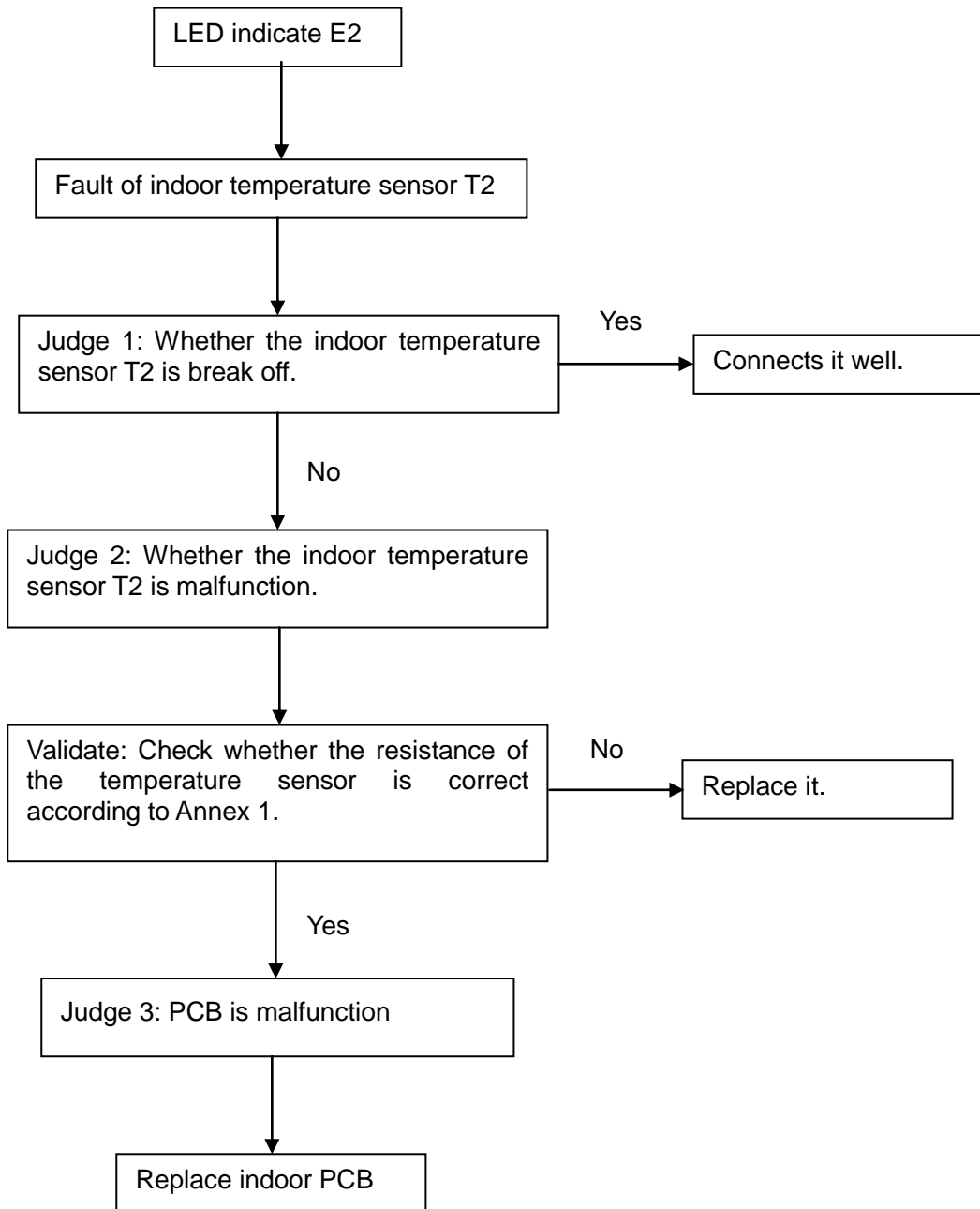

### 11.3 P1 malfunction

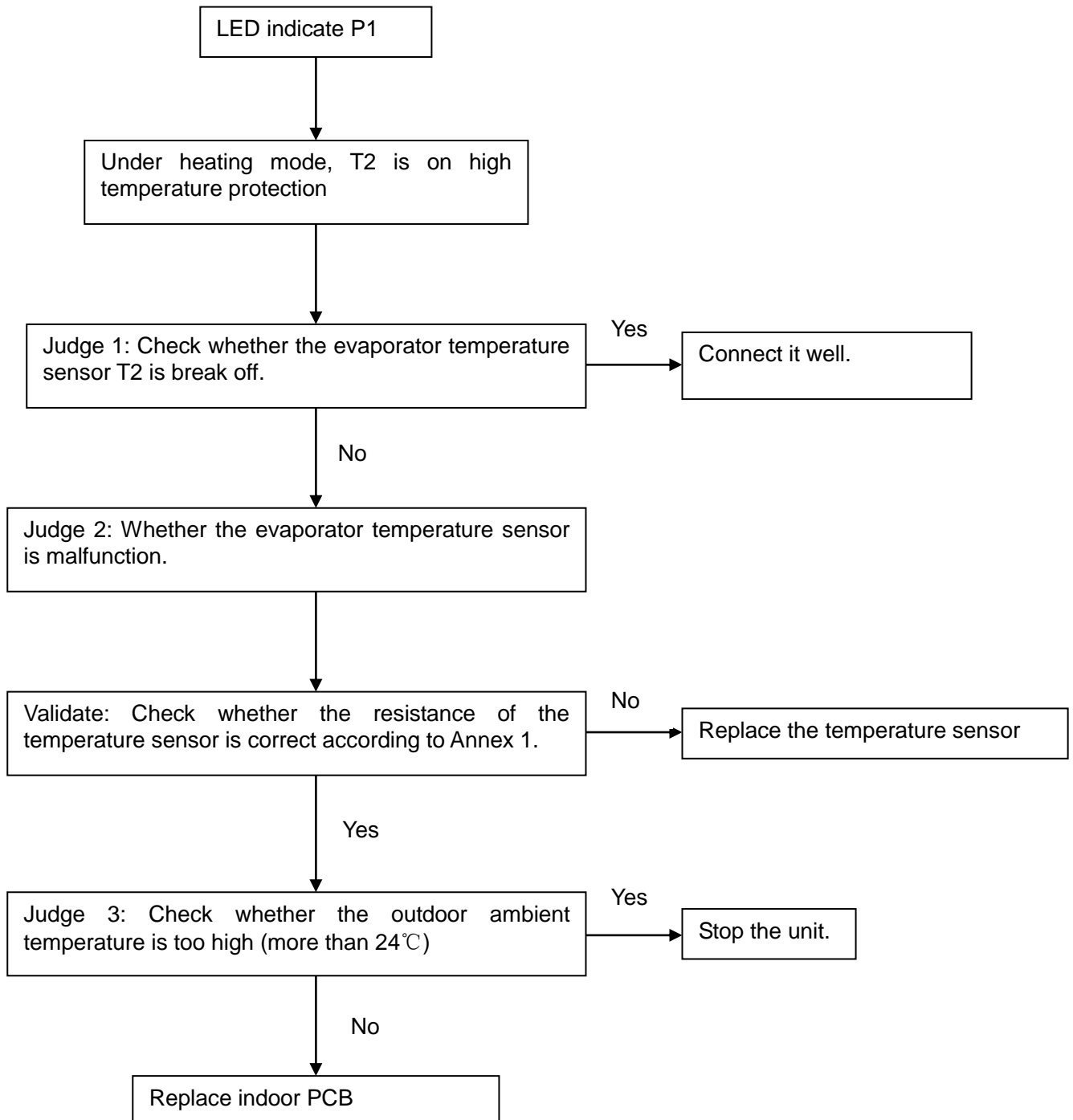

## 11.4 P2 malfunction

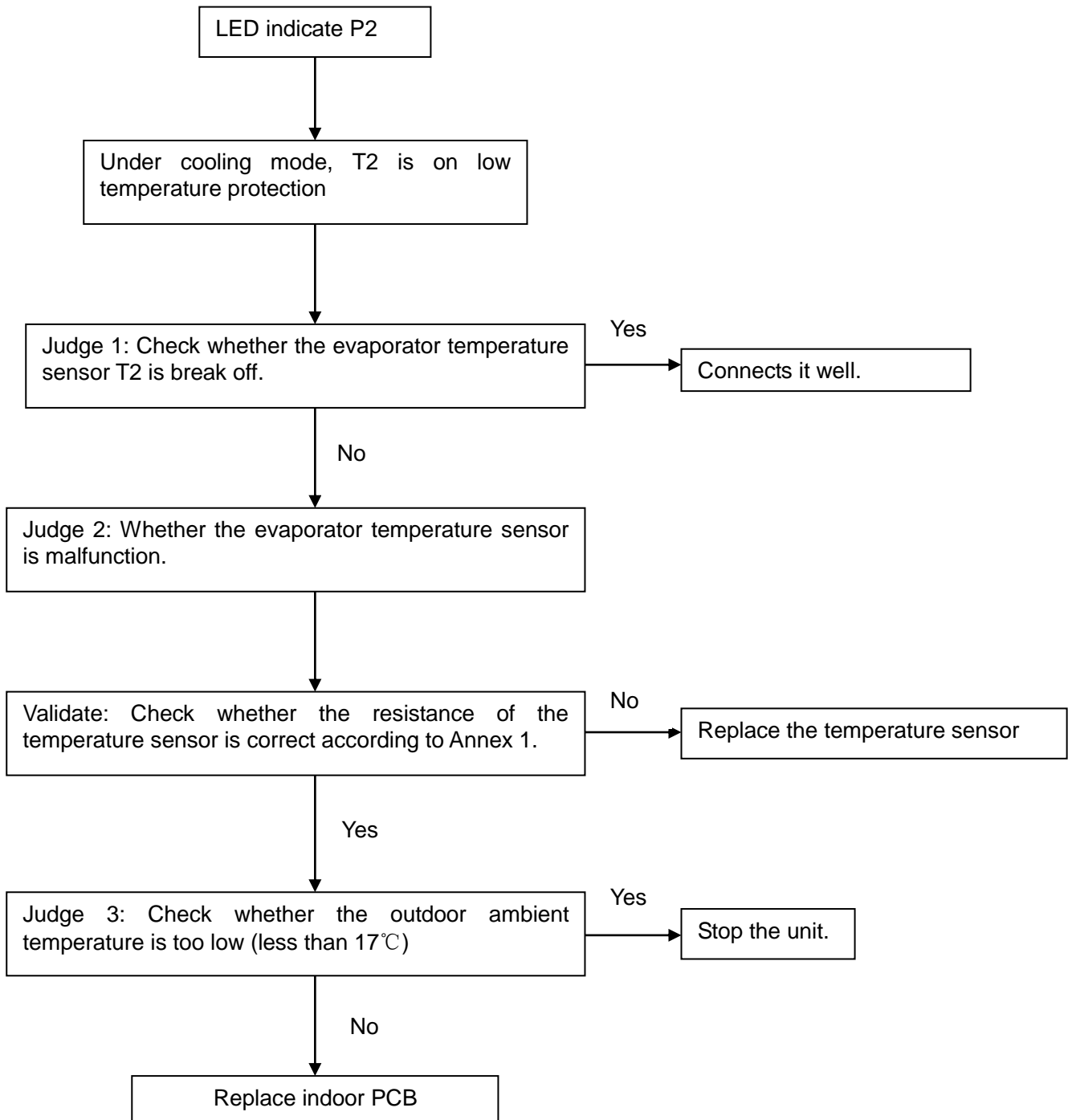

---

## **Part 3 Outdoor Units**

<b>1. Specifications</b> .....	<b>51</b>
<b>2. Dimension</b> .....	<b>53</b>
<b>3. Service Space</b> .....	<b>55</b>
<b>4. Wiring Diagrams</b> .....	<b>56</b>
<b>5. Electric Characteristics</b> .....	<b>59</b>
<b>6. Operation Limits</b> .....	<b>60</b>
<b>7. Sound Levels</b> .....	<b>60</b>
<b>8. Exploded View</b> .....	<b>Ошибка! Закладка не определена.</b>
<b>9. Troubleshooting</b> .....	<b>61</b>

# 1. Specifications

Model		MDOV-76C-CN2	MDOV-76H-CN2	MDOV-96C-CN2
Code		220075900100	220075900090	220075900060
Power supply	-	380~415V-3N-50Hz		380~415V-3N-50Hz
Ambient temp range	°C	21~52	-10~52	21~52
Rated input	W	11500	11500	14500
Rated current	A	20	20	28
Noise level	dB(A)	63	63	64
Compressor	Type	-	Scroll	Scroll
	Brand	-	HITACHI	HITACHI
	Model	-	403DH-64D2Y	403DH-64D2Y
	Qty.	-	2	2
	Capacity	Btu/h	40356	40356
	Input	W	3600	3600
	Rated current (RLA)	A	6.3	6.3
	Locked rotor Amp (LRA)	A	48	48
Refrigerant	Type	-	R407C	R407C
	Charge	g	6200	6200
Outdoor fan motor	Type	-	Axial fan	Axial fan
	Dimension	mm	Φ530	Φ530
	Drive type/ motor step	-	Direct/ Single	Direct/ Single
	Motor model	-	YDK210-6A	YDK210-6A
	Motor input	W	293+280	293+280
	Motor speed(Hi)	rpm	917/930	917/930
Outdoor coil	Type	-	Copper tube and aluminum fin	Copper tube and aluminum fin
	Tube size	mm	Φ7.94	Φ7.94
	No. of rows	-	2	2
	Fin per inch	FPI	18	18
	Length * height	mm	2171*880	2171*880
Refrigerant piping	Liquid side/ Gas side	mm	Φ12.7/Φ22	Φ12.7/Φ22
	Max. pipe length	m	50	50
	Max. difference in level	m	30	30
Connection wiring	Power wiring	mm <sup>2</sup>	5*6.0	5*6.0
	Signal wiring	mm <sup>2</sup>	2*1.0	4*1.0
Outdoor unit	Dimension (W*H*D)	mm	1260*908*700	1260*908*700
	Packing (W*H*D)	mm	1320*1060*730	1320*1060*730
	Net/ Gross weight	kg	161/194	164/179

## Notes:

1. Nominal cooling capacities are based on the following conditions:

Indoor temp: 27°CDB, 19°CWB; Outdoor temp: 35°CDB; Equivalent refrigerant piping: 7.5m (horizontal)

2. Nominal heating capacities are based on the following conditions:

Indoor temp: 20°CDB; Outdoor temp: 7°CDB, 6°CWB; Equivalent ref. piping: 7.5m (horizontal)

Model		MDOV-96H-CN2	MDOV-120C-CN2	MDOV-120H-CN2
Code		220075900050	220075900080	220075900070
Power supply	-		380~415V-3N-50Hz	
Ambient temp range	°C	-10~52	21~52	-10~52
Rated input	W	14700	18000	18000
Rated current	A	28.1	28.7	28.7
Noise level	dB(A)	64	65	65
Compressor	Type	-	Scroll	Scroll
	Brand	-	HITACHI	HITACHI
	Model	-	503DH-83D2Y	603DH-95D2Y-X10
	Qty.	-	2	2
	Capacity	Btu/h	52800	60342
	Input	W	4550	5300
	Rated current (RLA)	A	8	9.1
Refrigerant	Locked rotor Amp (LRA)	A	53	57
	Type	-	R407C	R407C
Refrigerant	Charge	g	6500	10000
	Type	-	R407C	R407C
Outdoor fan motor	Charge	g	6500	9500
	Type	-	Axial fan	Axial fan
	Dimension	mm	Φ530	Φ530
	Drive type/ motor step	-	Direct/ Single	Direct/ Single
	Motor model	-	YDK210-6A	YDK400-4C
	Motor input	W	293+280	400*2
Outdoor coil	Motor speed(Hi)	rpm	917/930	1180/790
	Type	-	Copper tube and aluminum fin	Copper tube and aluminum fin
	Tube size	mm	Φ7.94	Φ7.94
	No. of rows	-	2	2
	Fin per inch	FPI	18	18
Refrigerant piping	Length * height	mm	2171*880	1376*880*2
	Liquid side/ Gas side	mm	Φ12.7/Φ25	Φ16/Φ28.6
	Max. pipe length	m	50	50
Connection wiring	Max. difference in level	m	30	30
	Power wiring	mm <sup>2</sup>	5*6.0	5*6.0
Outdoor unit	Signal wiring	mm <sup>2</sup>	4*1.0	2*1.0
	Dimension (W*H*D)	mm	1260*908*700	1260*908*700
	Packing (W*H*D)	mm	1320*1060*730	1320*1060*730
	Net/ Gross weight	kg	180/195	193/208
				196/211

**Notes:**

1. Nominal cooling capacities are based on the following conditions:

Indoor temp: 27°CDB, 19°CWB; Outdoor temp: 35°CDB; Equivalent refrigerant piping: 7.5m (horizontal)

2. Nominal heating capacities are based on the following conditions:

Indoor temp: 20°CDB; Outdoor temp: 7°CDB, 6°CWB; Equivalent ref. piping: 7.5m (horizontal)

## 2. Dimension

### 2.1 MDOV-76C(H)-CN2, MDOV-96C(H)-CN2

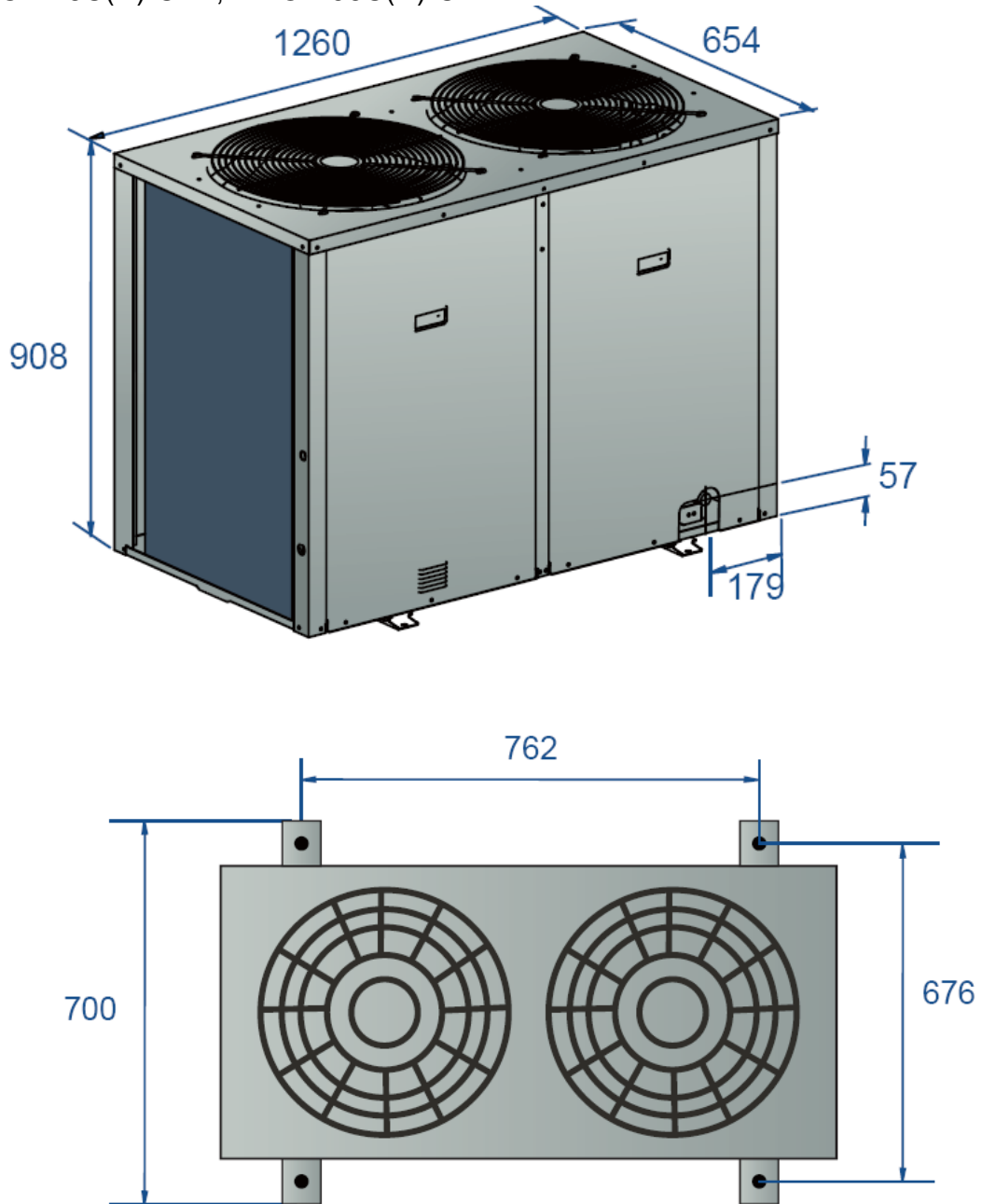

## 2.2 MDOV-120C(H)-CN2

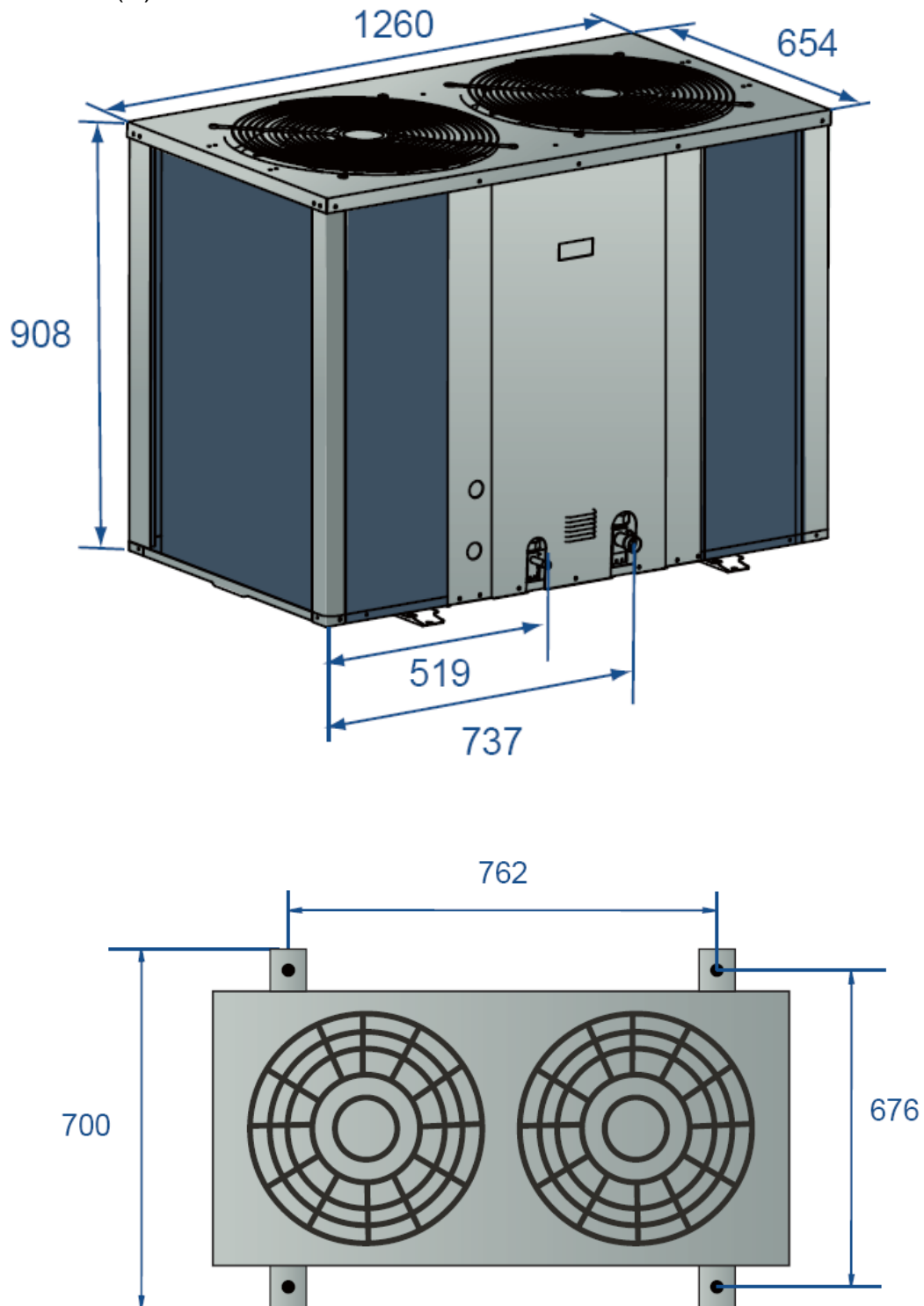



### 3. Service Space

#### 3.1 MDOV-76C(H)-CN2, MDOV-96C(H)-CN2, MDOV-120C(H)-CN2,

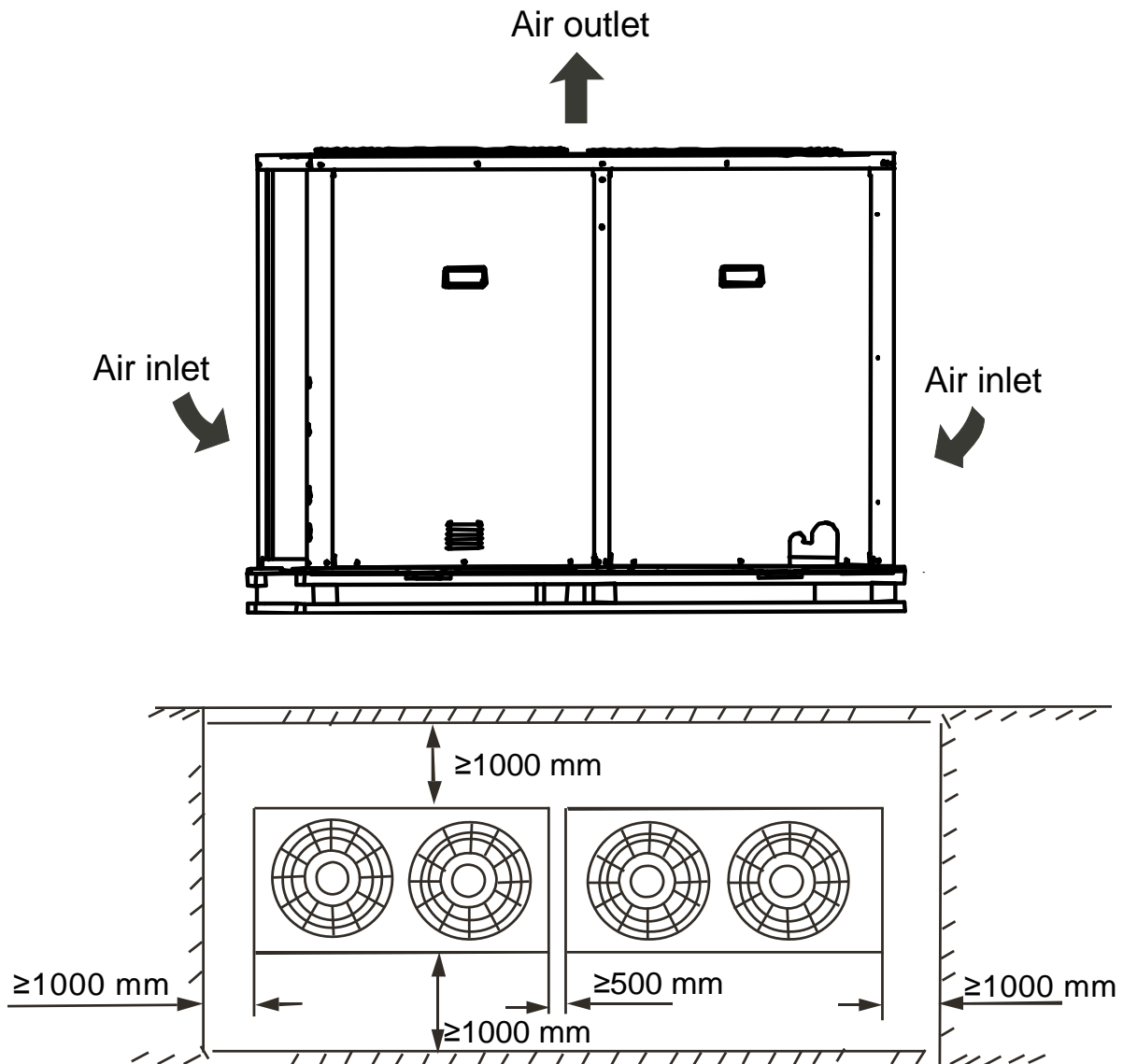

**Note:**

1. In case any obstacles exist above the outdoor unit, such obstacles must be 2000mm above the outdoor unit.
2. If miscellaneous articles are piled around the outdoor unit, such articles must be 400mm below the top of the outdoor unit.

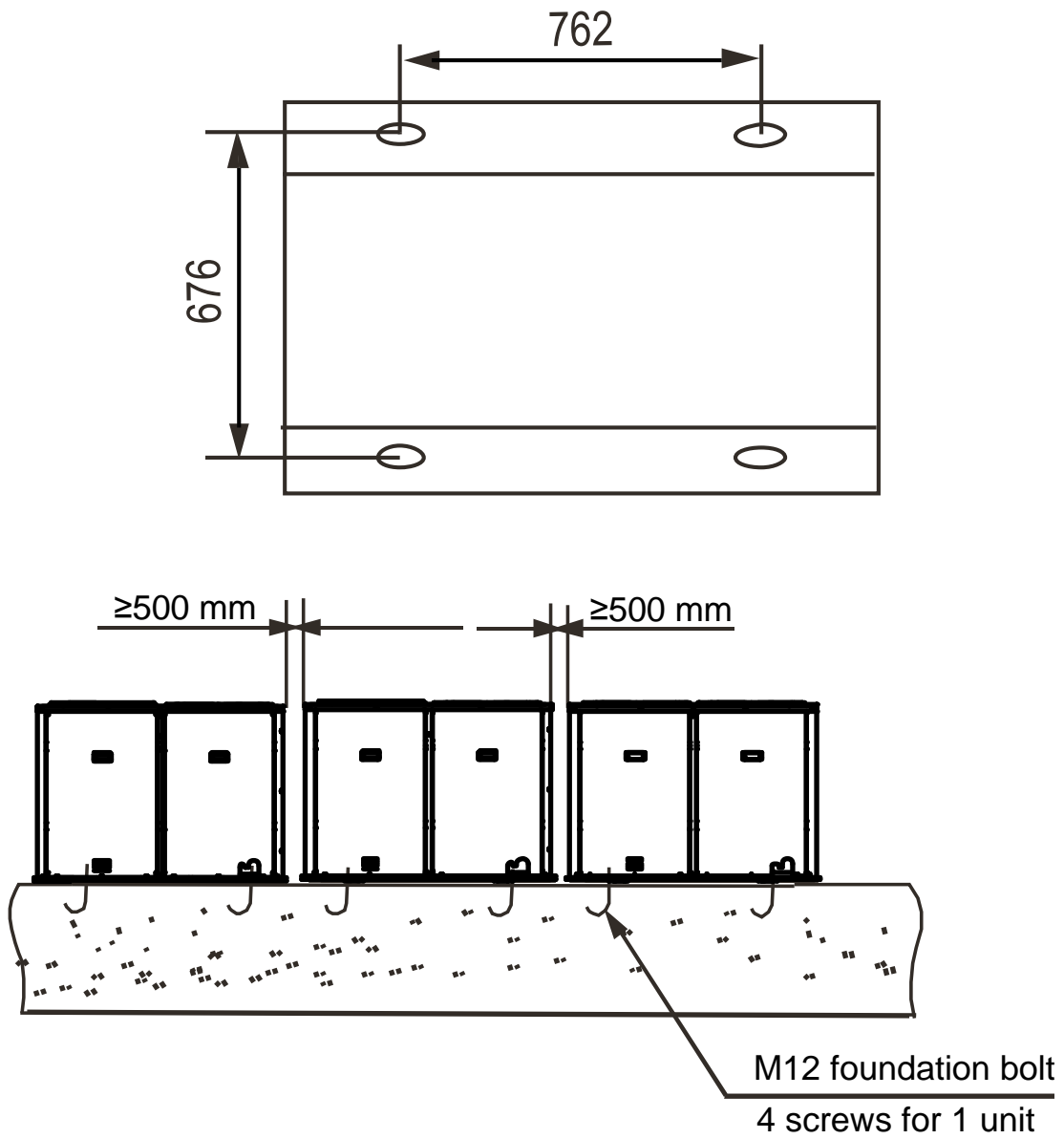
**Foundation of the outdoor unit**

# 4. Wiring Diagrams

## 4.1 MDOV-76C-CN2, MDOV-96C-CN2, MDOV-120C-CN2

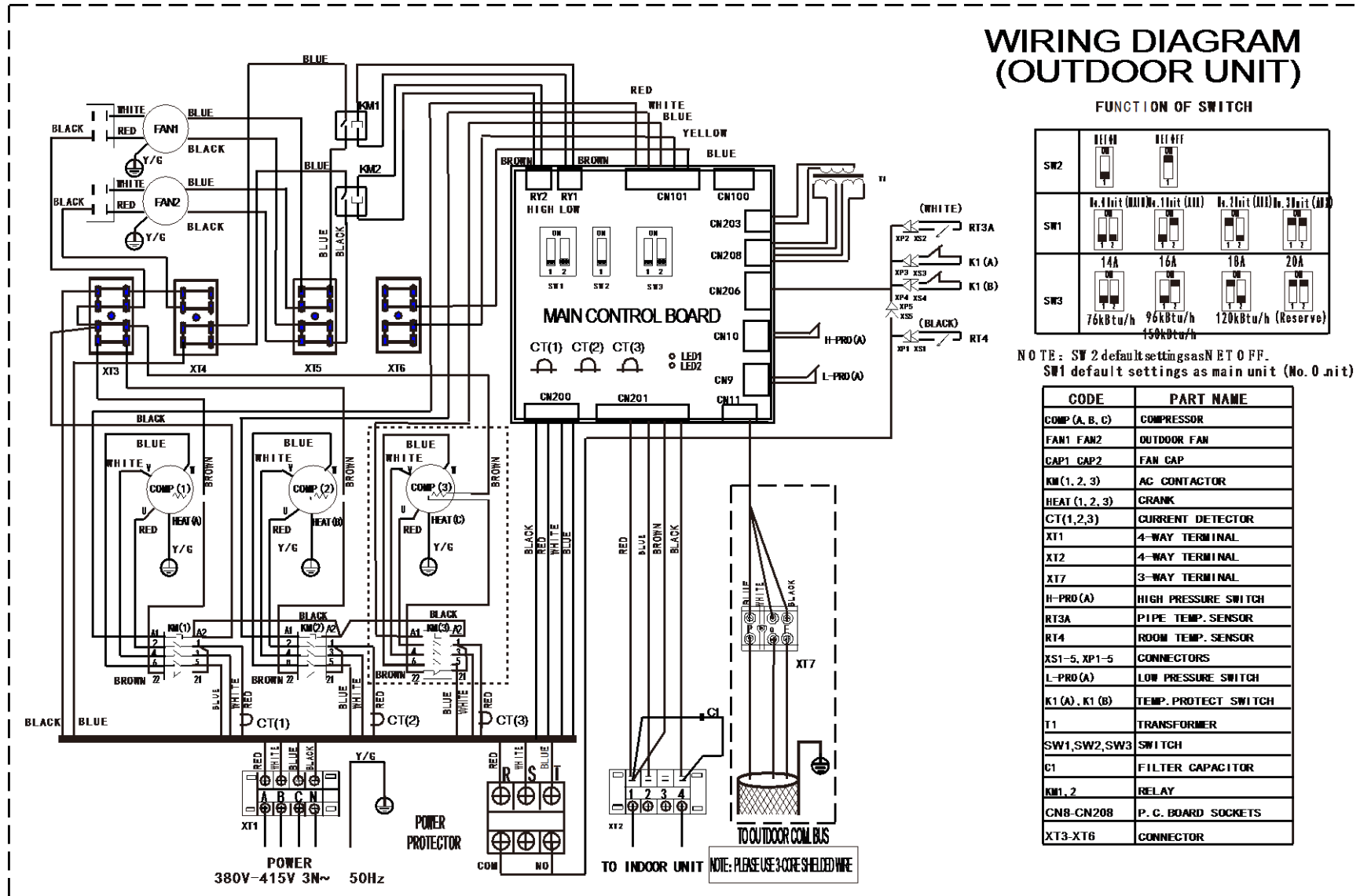

4.2 MDOV-76H-CN2, MDOV-96H-CN2, MDOV-120H-CN2

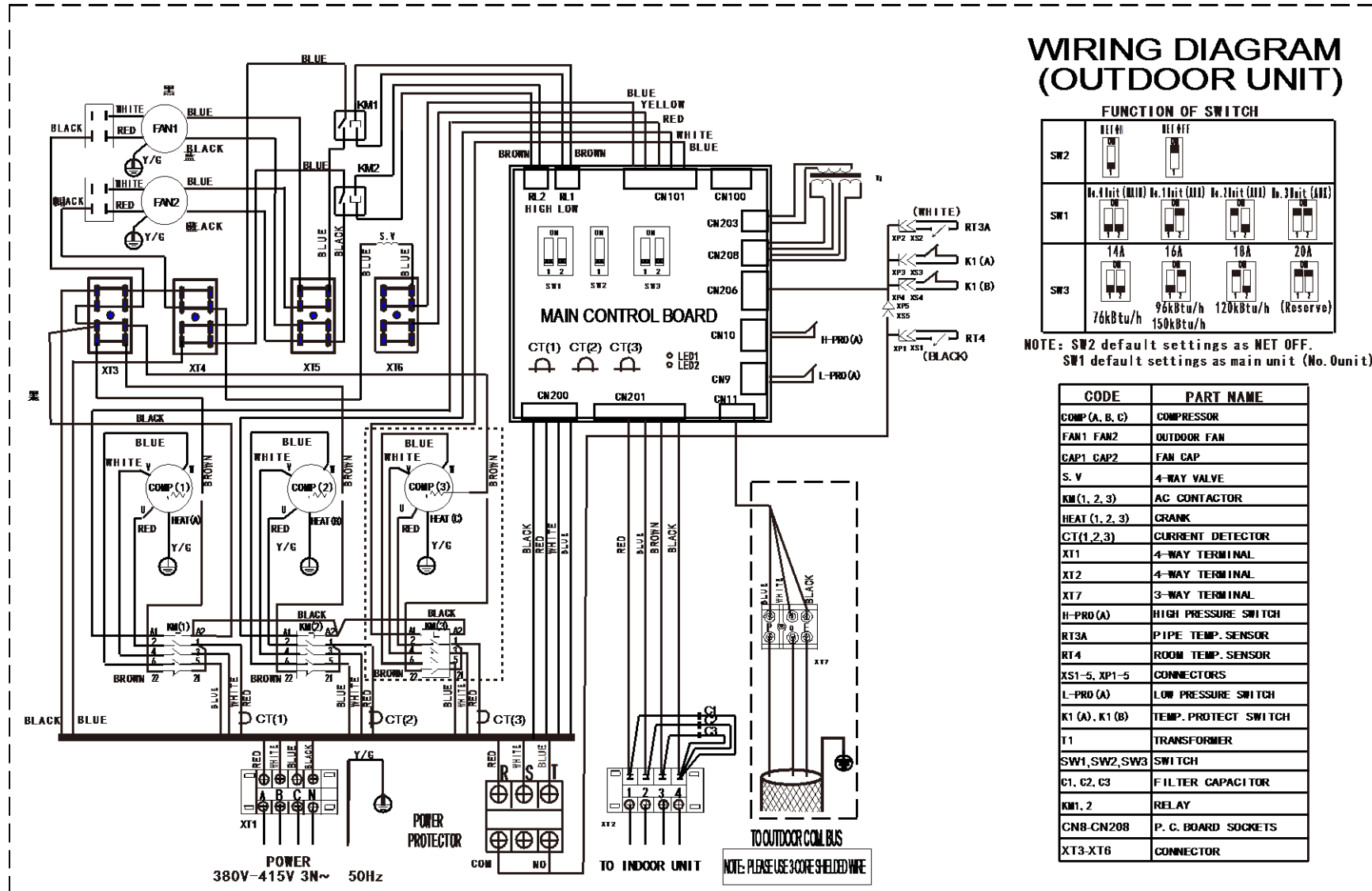

## 5. Electric Characteristics

Model	Outdoor Unit				Power Supply			Compressor		OFM	
	Hz	Voltage	Min.	Max.	MCA	TOCA	MFA	MSC	RLA	KW	FLA
MDOV-76C-CN2	50	380-415	342	438	15.75	18.5	21.85	48*2	6.3*2	0.573	2.613
MDOV-76H-CN2	50	380-415	342	438	15.75	18.5	21.85	48*2	6.3*2	0.573	2.613
MDOV-96C-CN2	50	380-415	342	438	20	28	30	53*2	8.0*2	0.573	2.613
MDOV-96H-CN2	50	380-415	342	438	20	28	30	53*2	8.0*2	0.573	2.613
MDOV-120C-CN2	50	380-415	342	438	22.75	28.7	32.55	57*2	9.1*2	1.2	5.857
MDOV-120H-CN2	50	380-415	342	438	22.75	28.7	32.55	57*2	9.1*2	1.2	5.857

**Remark:**

MCA: Min. Current Amps. (A)

TOCA: Total Over-current Amps. (A)

MFA: Max. Fuse Amps. (A)

MSC: Max. Starting Amps. (A)

RLA: Rated Locked Amps. (A)

OFM: Outdoor Fan Motor.

FLA: Full Load Amps. (A)

KW: Rated Motor Output (kW)

## 6. Operation Limits

Temperature range for unit operation:

Model \ Item	Cooling mode		Heating mode	
	Outdoor	Indoor	Outdoor	Indoor
All model	21°C~52°C	17°C~32°C	-10°C~24°C	20°C~27°C

## 7. Sound Levels

Standard of testing

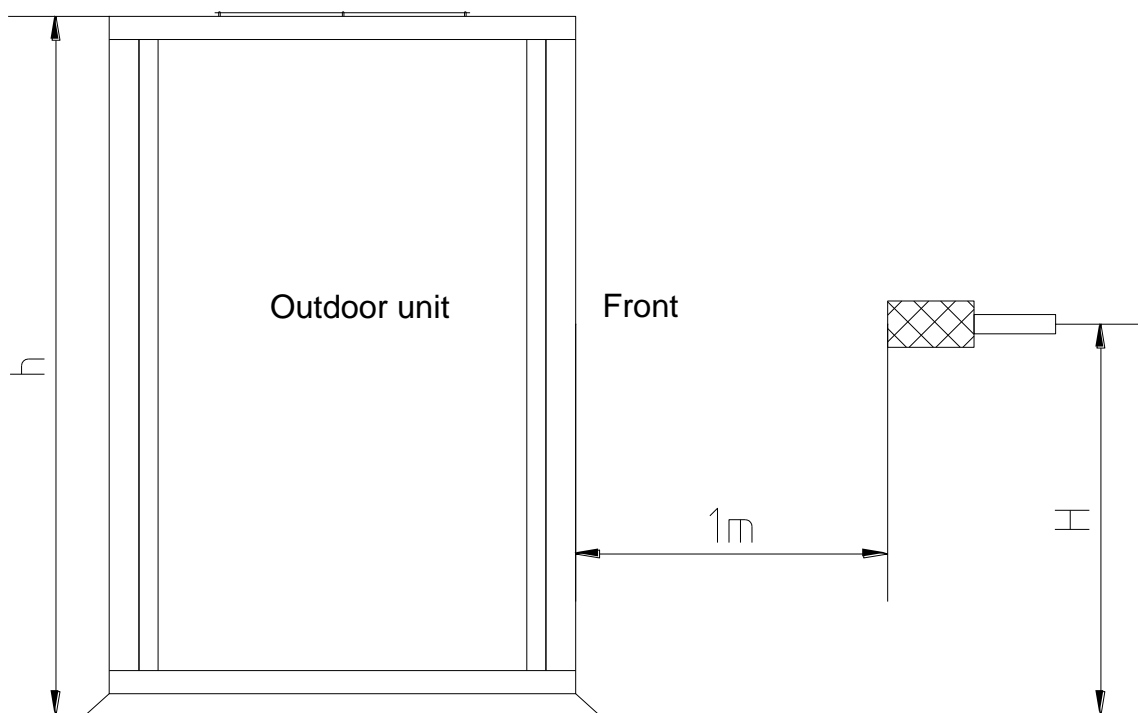

Note:  $H = (h+1) / 2$

Unit Number	Model	Noise level (dB(A))
1	MDOV -76C(H) -CN2	63
2	MDOV -96C(H) -CN2	64
3	MDOV -120C(H) -CN2	65

## 9. Troubleshooting

Type	LED1	LED2	Remarks
Standby	☆	☆	-
Cooling mode	◆	◇	-
Heating mode	◆	◆	-
Defrosting mode	◇	◆	-
Phase sequence protection	◆	●★	Manual reset
Communication failure	◆	●●★	Manual reset
Outdoor condenser temp. sensor error	◆	●●●★	Manual reset
Outdoor ambient temp. sensor error	◆	●●●●★	Manual reset
Protection of low pressure	◇	●★	Auto reset
Protection of high pressure	◇	●●★	Auto reset
Protection of over-current	◇	●●●★	Auto reset
Protection of condenser hi-temp.	◇	●●●●★	Auto reset

**Note:**

☆: Light for 1 second, extinguish for 1 second;

◆: Light;

◇: Extinguish;

●: Light for 0.4 second, extinguish for 0.4 second;

★: Light for 2 second, extinguish for 2 second.

---

## Malfunctions:

About the Fault of T3A or T3B, High pressure protection, low pressure protection  
Please refer to the following:

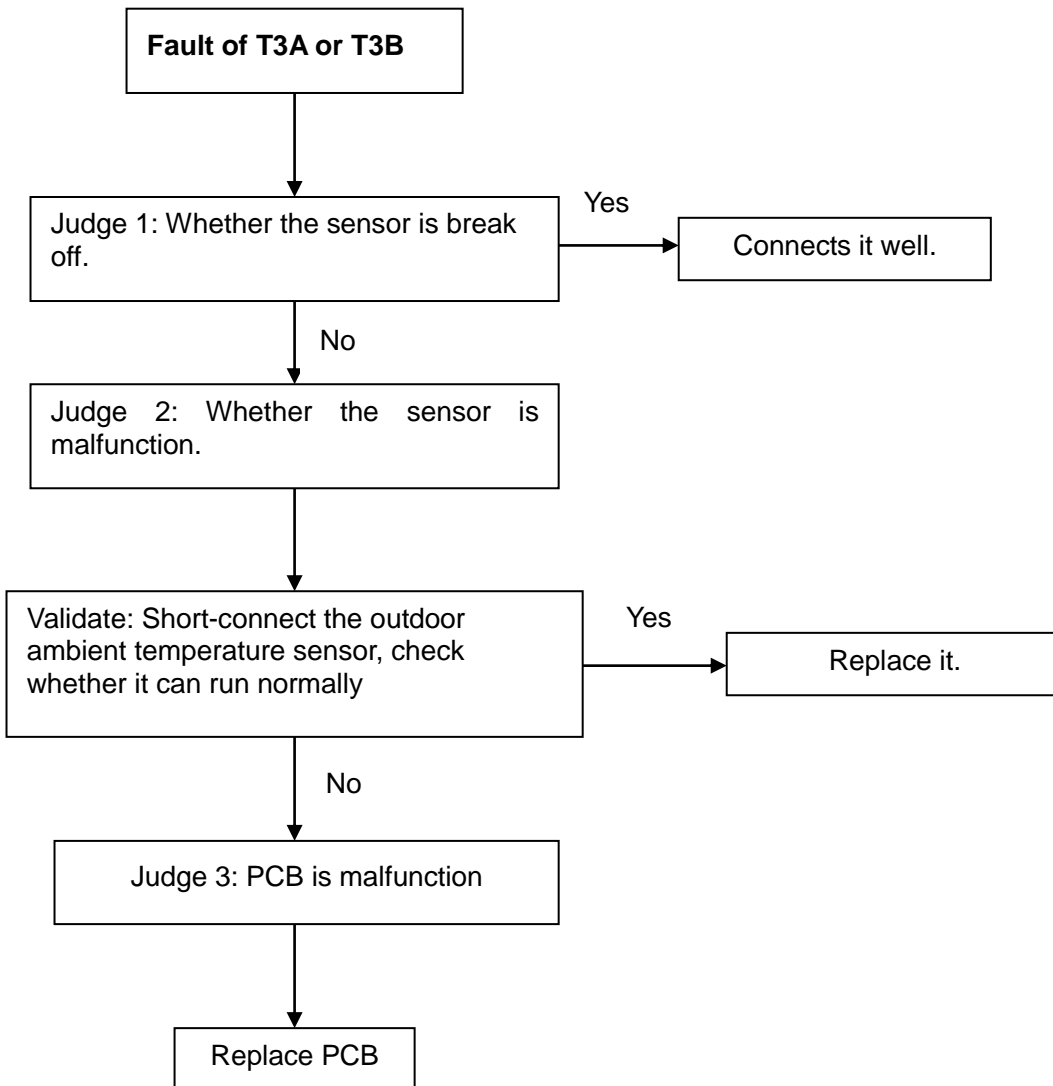



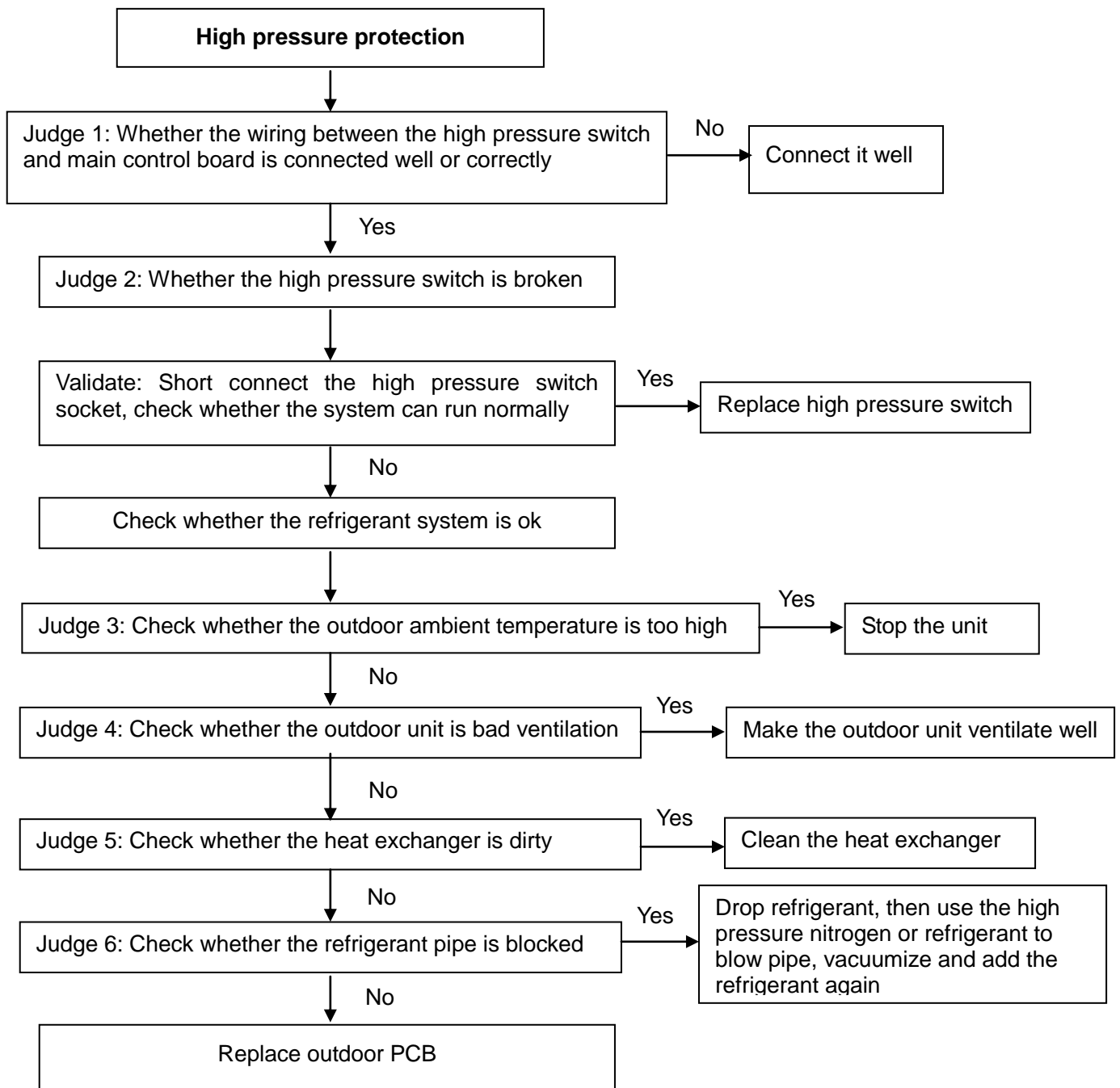

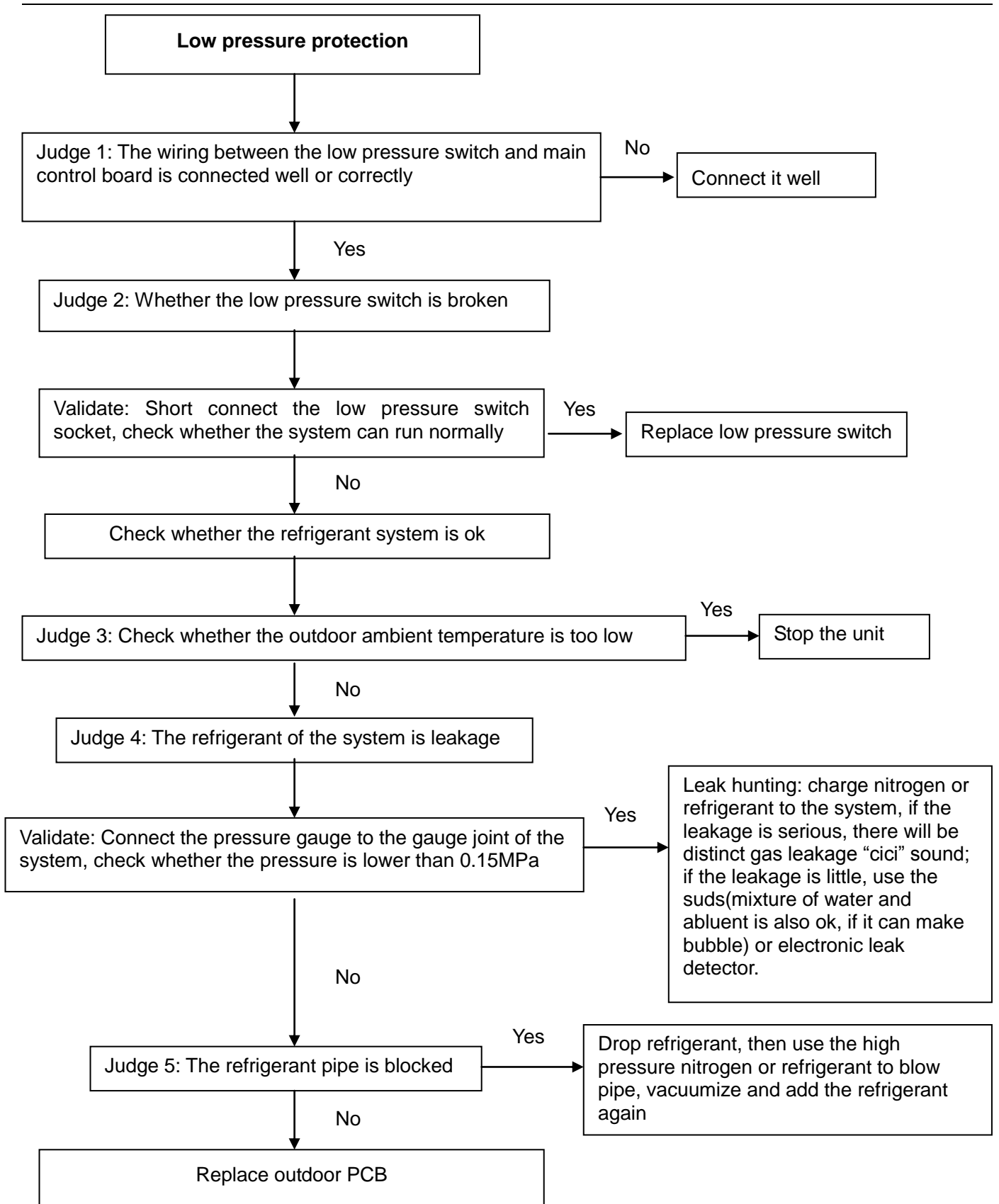

# Part 4 Installation

<b>1. Note .....</b>	<b>65</b>
<b>2. Installation of Indoor Units .....</b>	<b>66</b>
<b>3. Installation of Outdoor Units .....</b>	<b>71</b>
<b>4. Heat Insulation of the Pipe.....</b>	<b>81</b>
<b>5. Installation of Connective Pipe.....</b>	<b>82</b>
<b>6. Installation of Drain Pipe.....</b>	<b>87</b>
<b>7. Electric Connection.....</b>	<b>88</b>
<b>8. Methods of configuring and selecting installation.....</b>	<b>90</b>

## 1. Note

### CAUTION:

- Install the unit where enough space of installation and maintenance is available.
- Install the unit where the ceiling is horizontal and enough for bearing the weight of the indoor unit.
- Install the unit where the air inlet and outlet are not baffled and are the least affected by external air.
- Install the unit where the supply air flow can be sent to all parts in the room.
- Install the unit where it is easy to lead out the connective pipe and the drain pipe.
- Install the unit where no heat is emitted from a heat source directly.
- Installing the equipment in any of the following places may lead to faults of the equipment (if that is inevitable, consult the supplier):
  - The site contains mineral oils such as cutting lubricant.
  - Seaside where the air contains much salt.
  - Hot ring area where corrosive gases exist, e.g., sulfide gas.
  - Factories where the supply voltage fluctuates seriously.
  - Inside a car or cabin.
  - Place like kitchen where oil permeates.
  - Place where strong electromagnetic waves exist.
  - Place where flammable gases or materials exist.
  - Place where acid or alkali gases evaporate.
  - Other special environments.
- Install the unit where enough space of installation and maintenance is available.
- Install the unit where the air inlet and air outlet are free from obstacles and strong wind.
- Install the unit in a dry and well ventilated place.
- Install the unit where the bearing surface is level and can bear weight of the unit, and is suitable for installing the unit horizontally without increasing noise or vibration.
- Install the unit where the operation noise and the expelling of air do not affect neighbors.
- Install the unit where no flammable gas is leaked.
- Install the unit where it is convenient for pipe connection and electric connection.

## 2. Installation of Indoor Units

### 2.1 Installation of Duct

#### 2.1.1 Installation Space

Ensure enough space required for installation and maintenance. (Fig-1 and Fig-2)

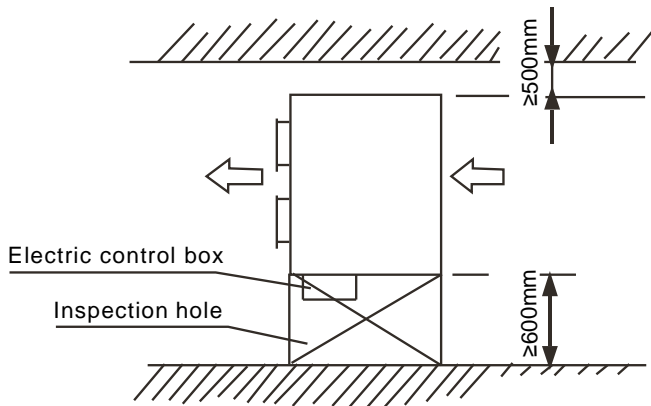

Fig-1

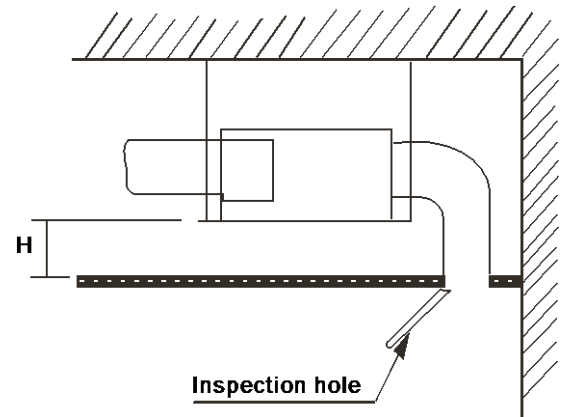

Fig -2

#### 2.1.2 Install $\Phi 10$ Pendant Bolts Or Ground Bolts (Fig-3)

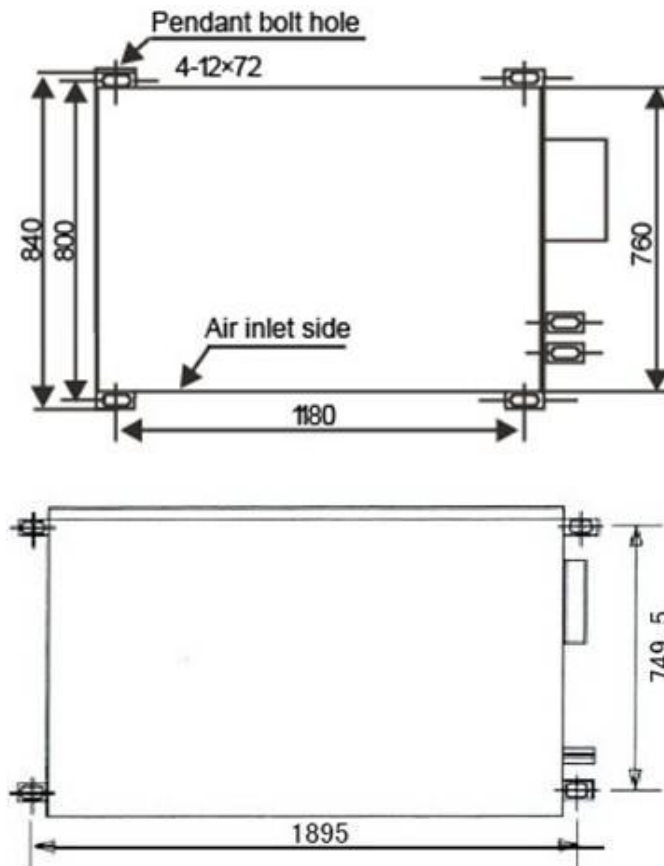

Fig-3

MTA-76C(H)R  
MTA-96C(H)R

MTA-120C(H)R  
MTA-150C(H)R

1. Use f10 or bigger screws. The screw material is high-quality carbon steel (whose surface is zinc plated or undergoes other rustproof treatment) or stainless steel.
2. The treatment of the ceiling varies between buildings. For detailed measures, consult with the fitting-out staff.
3. Fix the pendant bolts firmly and reliably in light of the specific situation.
4. Installation of the pendant bolt in different environments.

**A. Wooden structure**

Put rectangular sticks across the beams, and set pendant bolts. (Fig-4)

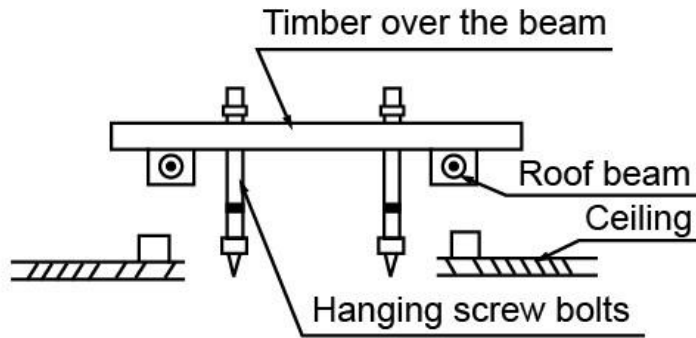

Fig-4

**B. New concrete roughcast**

Use embedded bolts, embedded pulling plugs, and embedded stick harness. (Fig-5)

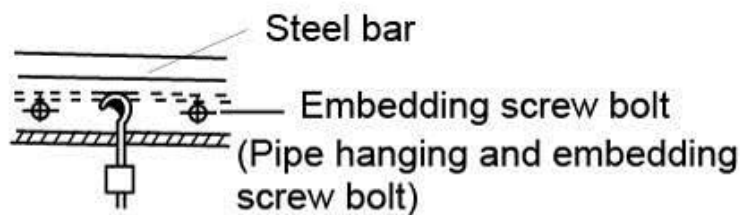

Fig-5

**C. New concrete roughcast**

Set it with embedded bushes or embedded bolts. (Fig-6)



Fig-6

**D. Steel beam and girder structure**

Set and use supportive angle steel. (Fig-7)

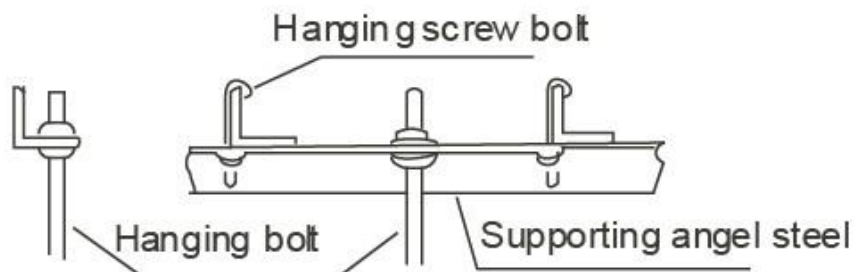

Fig-7

**2.1.3 Suspending the Indoor Unit**

Use a hoisting device to hoist the indoor unit, align it with the installation screw, adjust the horizontality and then tighten it. (Fig-8)

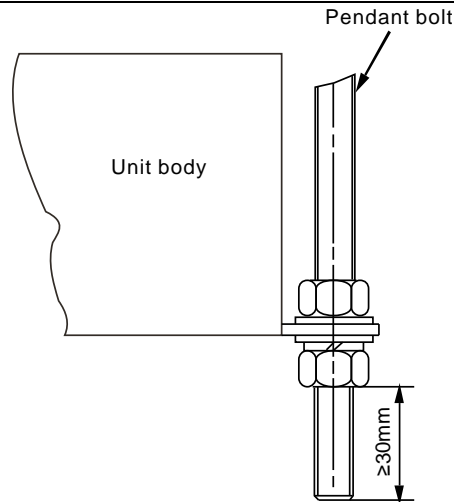

Fig-8

#### 2.1.4 Design and Connection of Duct

- The duct design must comply with the national heating air conditioner pipeline design specifications.
- The duct accessories and materials must be produced by professional manufacturers.
- In order to prevent air flow shorting, do not keep the air inlet pipe near the air outlet pipe.
- Install a filter at an easy-to-maintain place such as intake pipe. (Otherwise, the duct will gather on the air heat exchanger and lead to fault and water leak of the air conditioner.)
- In order to suppress noise effectively, install noise suppression and sound insulation devices, especially in the noise-sensitive spaces such as meeting rooms.
- For connection of the flange plane, use non-flammable canvas adapter to prevent transmission of vibration. For its size, see the indoor unit outline diagram. Use M6X20 screws (configured on site) for connection.
- All pipelines must be connected closely and soundly without leak of air. The pipelines must be adiabatic and free from condensation.

#### Key points of duct connection (Fig-9)

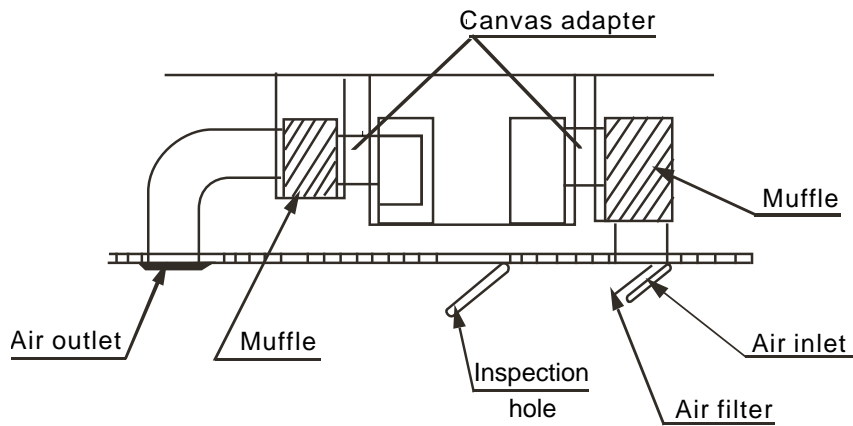

Fig-9

## 2.2 Installation of Floor-standing

### 2.2.1 Installation Space

For ensure the proper installation

Select the enough solid and level sites.

Ensure enough space required for installation and maintenance. (Fig-10and Fig-11)

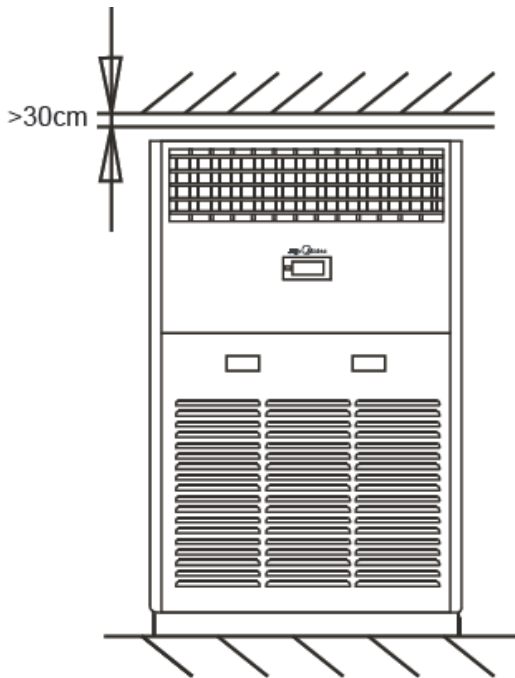

Fig-10

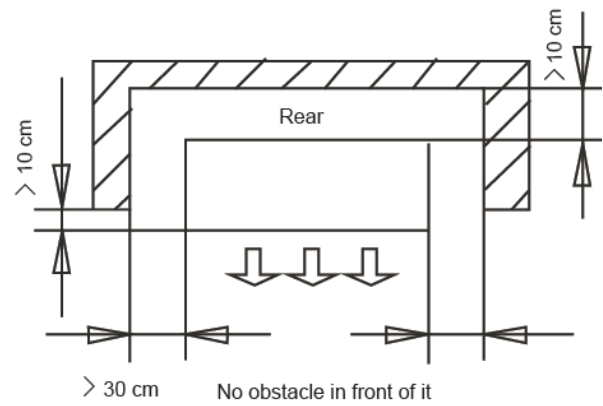
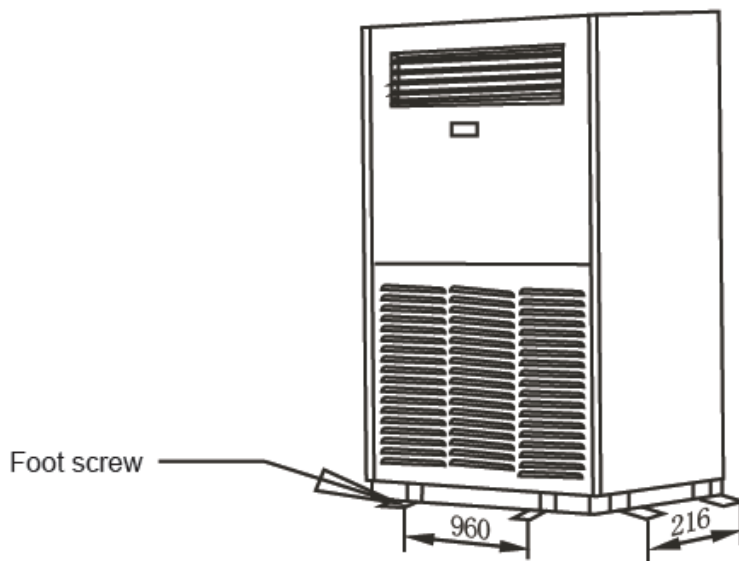

Fig-11

**For anti-fall down, please conduct the follow measures:**

- See Fig-12 to fix the feet on the floor after select a proper place for installation, since the height of this unit casing is very high.
- The right and left sides as well as rear can be fixed, please select the unit fixed measure as per to your actual installing ambient.



(Unit:mm)

Fig 12

### Put down the air intake panel, before electric connection:

- Uncover the screw-cap in the air intake panel, and then lessen the screws.
- Take off the air intake panel; ensure which place secure enough will not make risk to the other people.

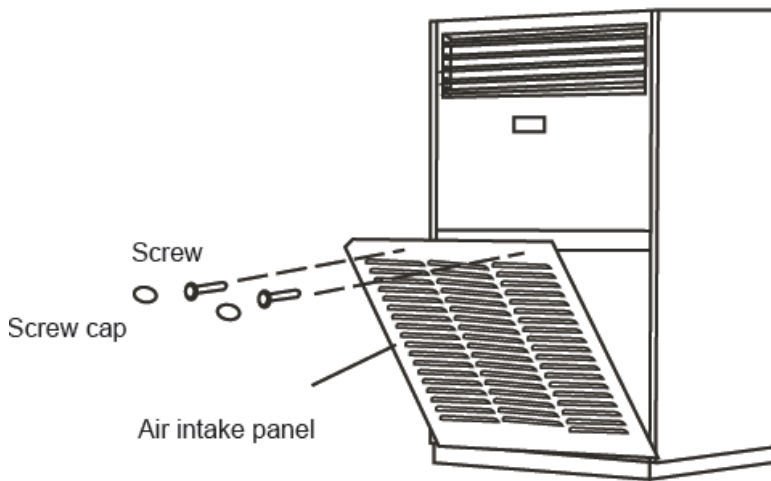

Fig-13

#### NOTE:

Please beware of the foot screw, which may be hurt for the pass-by people, make sure enough security of that, prevent accident occurs.

## 3. Installation of Outdoor Units

### 3.1 Important: Construction Checkpoints

#### 1). Installation

Check the model and name to avoid mistaken installation.

#### 2). Refrigerant pipe

- The refrigerant pipes must have the specified diameter.
- Nitrogen of a certain pressure must be filled into the refrigerant pipe before welding.
- The refrigerant pipe must undergo heat insulation treatment.
- After the refrigerant pipe is installed completely, the indoor unit cannot be powered on before performing the airtight test and creating a vacuum.

#### 3). Pressure test

The refrigerant pipe must undergo the airtight test [with 2.94MPa (30kgf/cm<sup>2</sup>G) nitrogen].

#### 4). Creating a vacuum

Be sure to use the vacuum pump to create a vacuum of the connective pipe at both air side and liquid side concurrently.

#### 5). Refrigerant replenishment

- If the pipe is longer than the reference pipe, the refrigerant replenishment quantity for each outdoor unit should be calculated through the formula obtained according to the actual length of the pipe.
- Record the refrigerant replenishment quantity, actual length of pipe and the height difference of the indoor & outdoor units onto the operation confirmation table (on the electric control box) of the outdoor unit in advance for future reference.

#### 6). Electric wiring

- Select the power supply capacity and wire size according to the design manual. The power wire size of the air conditioner should be greater than that of ordinary motors.



- In order to prevent disoperation of the air conditioner, do not interleave or entwine the power cable (380~415V/3N/50Hz) with the connection wires (low-voltage wires) of the indoor/outdoor unit.
- Power on the indoor unit after performing the airtight test and making a vacuum.

**7). Trial run**

Perform the trial run only after the outdoor unit has been powered on for over 12 hours.

**3.2 Installation Space**

- When installing the unit, leave a space for maintenance shown in the following figure. Install the power supply at the side of the outdoor unit.
- Ensure enough space for installation and maintenance. (Fig-14 and Fig-15)

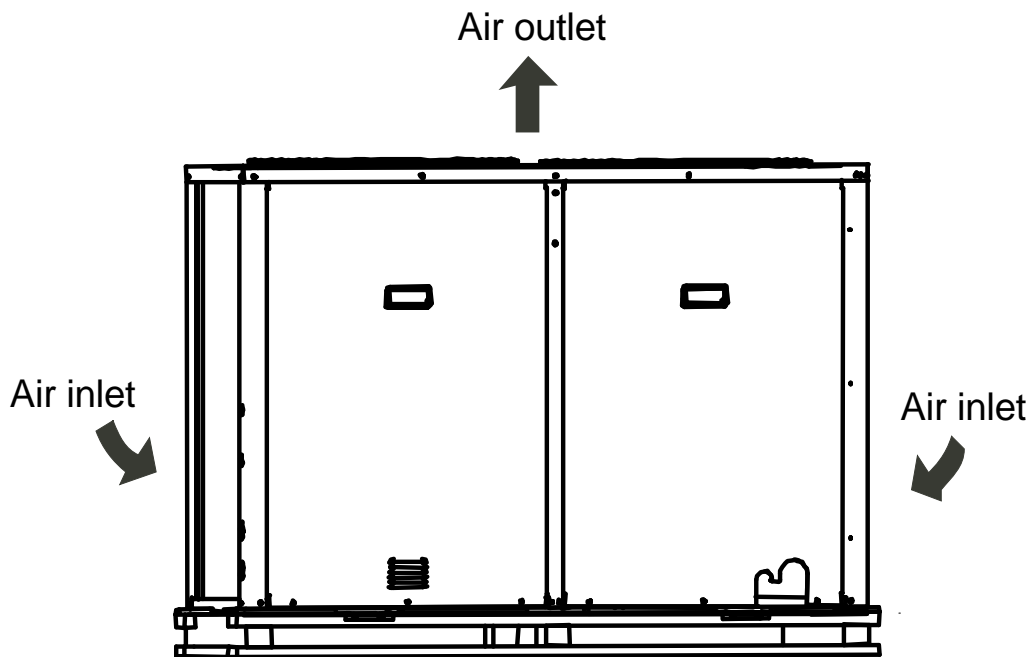

Fig-14

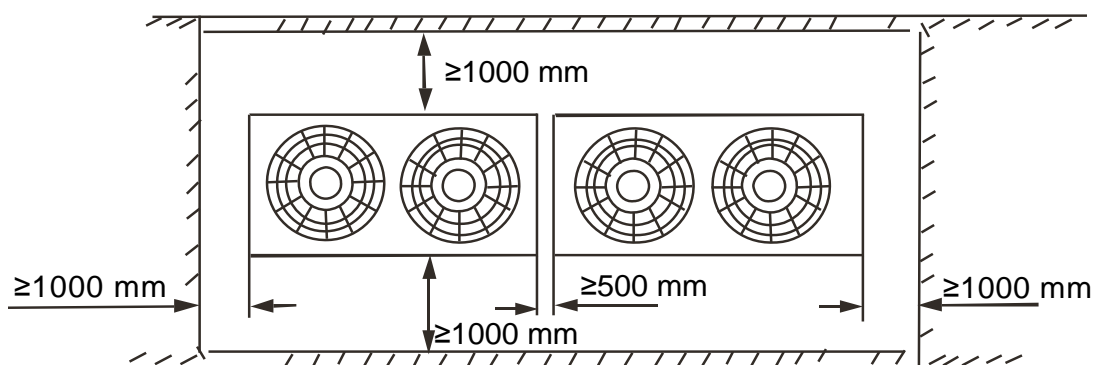

Fig-15

**NOTE:**

1. In case any obstacles exist above the outdoor unit, such obstacles must be 2000mm above the outdoor unit.
2. If miscellaneous articles are piled around the outdoor unit, such articles must be 400mm below the top of the outdoor unit.

As shown in Fig-16, leave an interval of 500mm between the outdoor units.

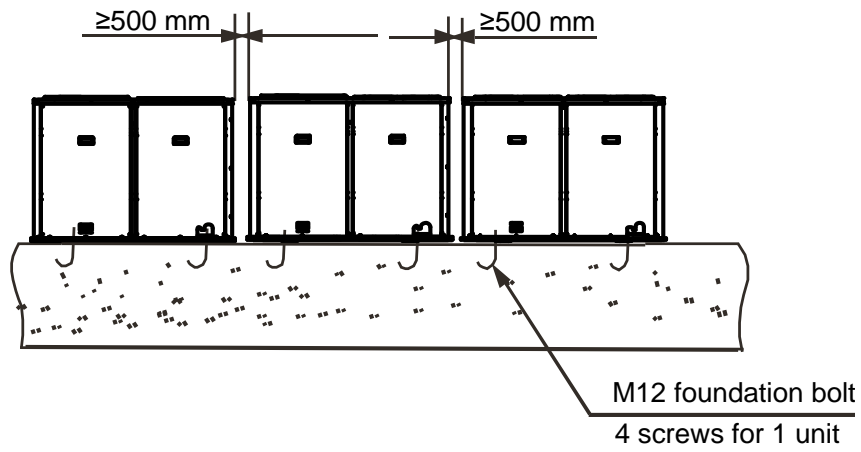

Fig-16

The distance of the foundation bolt is shown in Fig-17.

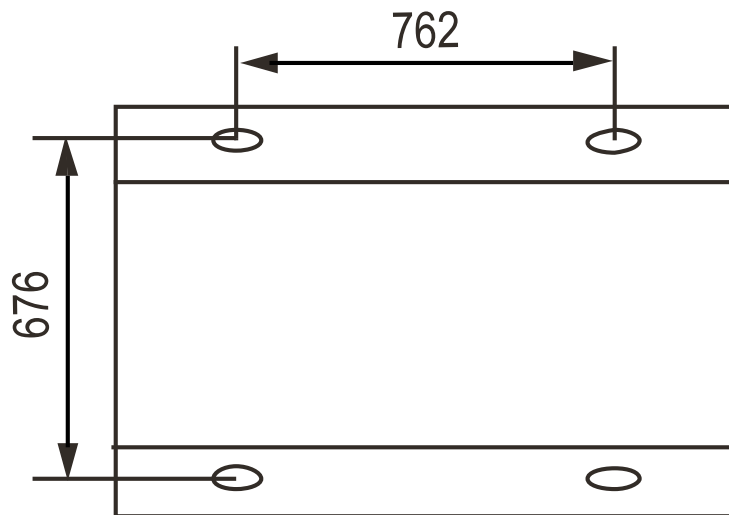

Fig-17

### 3.3 Convey Outdoor Unit

- Use 4 steel ropes of a  $\Phi 6\text{mm}$  or bigger size to hoist the outdoor unit and convey it into the room.
- In order to prevent scratch and deformity the outdoor unit, apply a guard board to the surface of contact between the steel ropes and the air conditioner.
- Remove the cushion for use in the transport after finishing the transport. (Fig-18)
- Fork truck can be used for conveying.

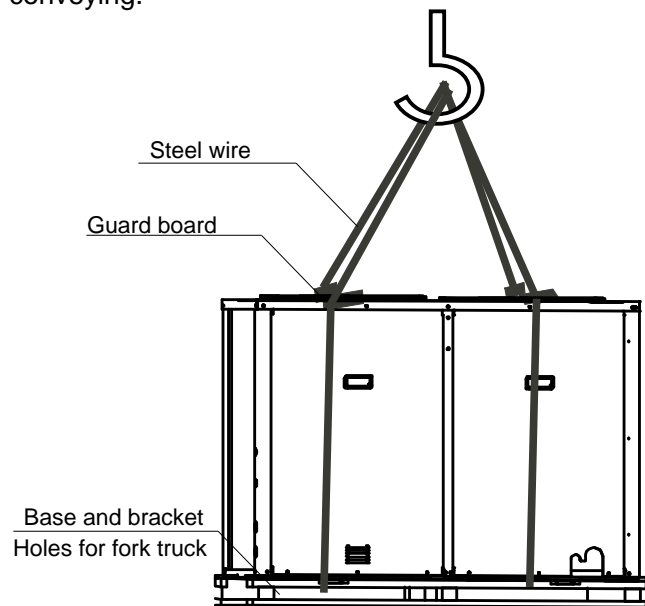

Fig-18

### 3.4 Snow protection facilities must be installed in the snowfall areas. (Fig-19)

In case the snow protection facilities are incomplete, faults may occur. In order to prevent influence caused by snow, set up raised pavilion, and install snow protection sheds at the air inlet and air outlet.

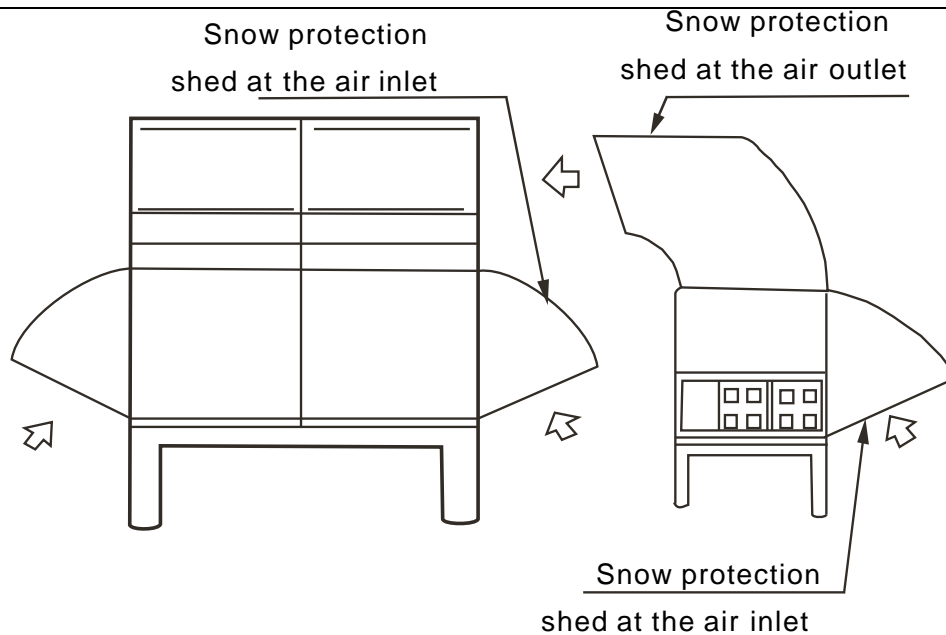

Fig-19

### 3.5 Installation of Refrigerant Pipe

- The refrigerant pipe adapter is located inside the outdoor unit. When the pipe is connected from the front side, the pipe can be let out through the right front board. (Fig-20 and Fig-21) So remove the left front board first. (Three M5 screws)
- The pipe can be connected from the front left lower side or the bottom notch of the outdoor unit.
- When the pipe is connected from the front side, the pipe can be led out through the pipe & wire panel.
- In case the pipe is connected from the bottom notch, install it leftward, rightward or backward after leading it out.
- When the pipe is led from the front, use a cover plate to seal the bottom notch in order to prevent intrusion of dust or trash.

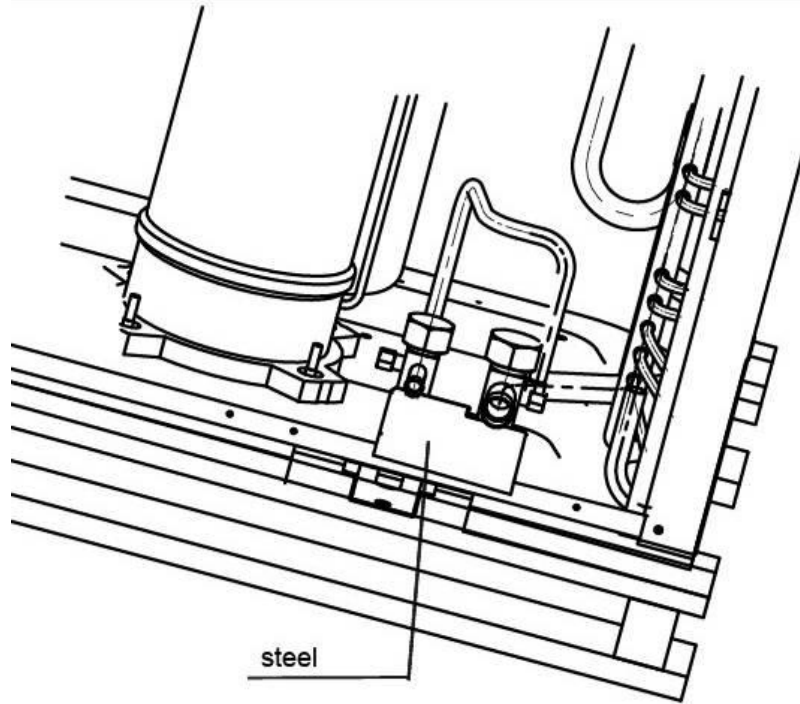

Fig-20

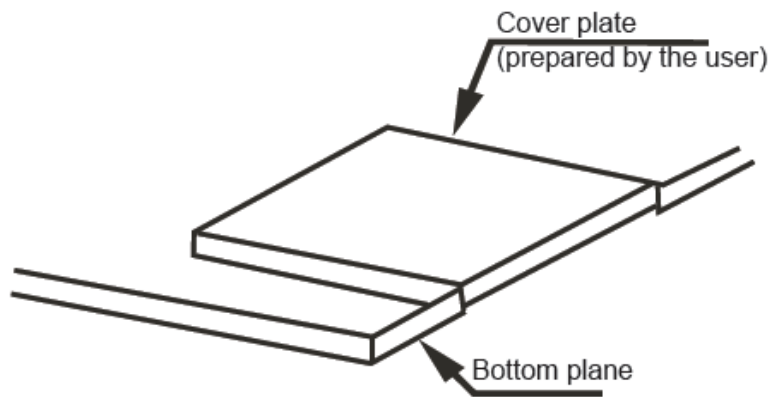

Fig-21

**NOTE:**

When welding the refrigerant pipe, in order to prevent internal oxidation of the pipe, nitrogen must be filled in. Otherwise, the oxidized chips may block refrigerating circulatory system.

**3.5.1 Size of Outdoor Unit Pipes and Piping Methods**

**1) Size of outdoor unit pipes and piping methods**

Model	Gas side	Liquid side
MDOV-76C-CN2	Φ22	Φ12.7
MDOV-76H-CN2	Φ22	Φ12.7
MDOV-96C-CN2	Φ25	Φ12.7
MDOV-96H-CN2	Φ25	Φ12.7
MDOV-120C-CN2	Φ28.6	Φ16
MDOV-120H-CN2	Φ28.6	Φ16

2) Allowed length of refrigerant pipe and height difference (Fig-22)

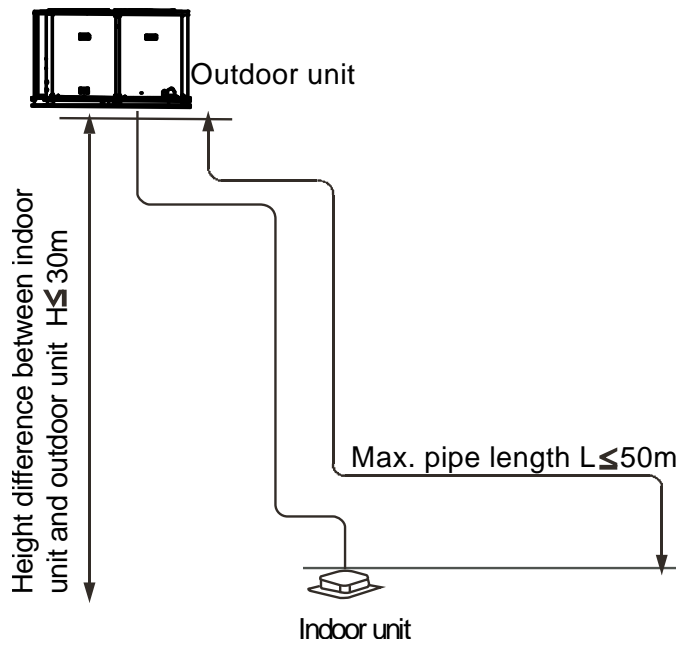
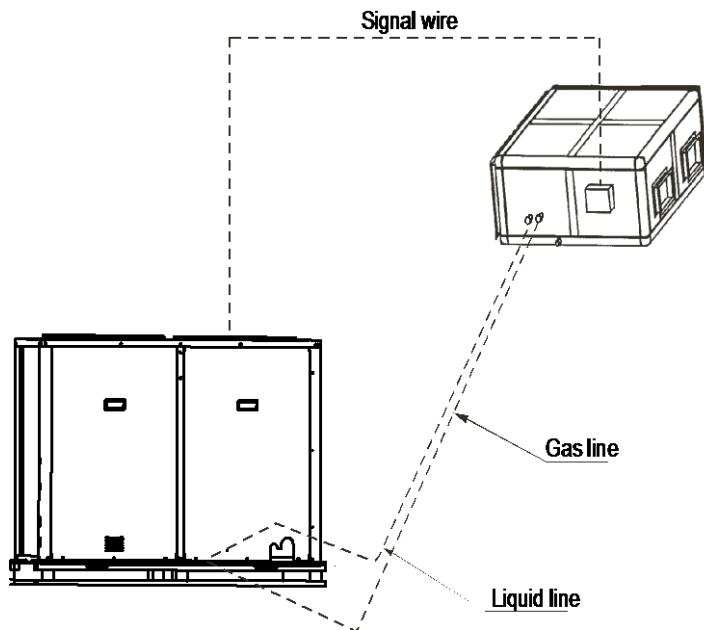

Fig-22

Table 1:

			76, 96, 150 kBtu/h	120 kBtu/h
Max. equivalent length of pipe (L)			50m	50m
Max. height difference	Height difference between indoor unit and outdoor unit (H)	Outdoor upper	30m	30m
		Outdoor lower	30m	30m

3) Connection between indoor unit and outdoor unit (Fig-23)



76, 96, 120 kBtu/h

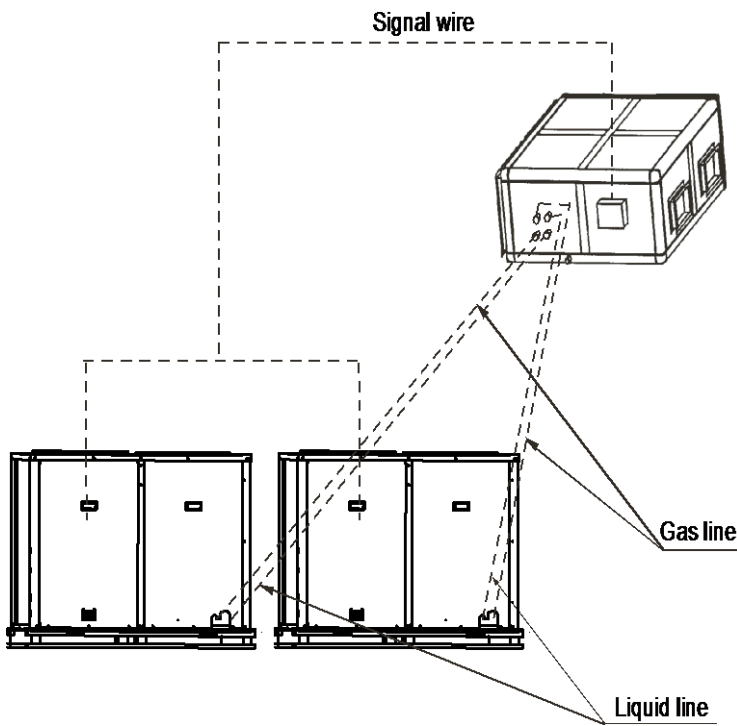

150 kBtu/h

Fig-23

### 3.6 Airtight Test

After the pipes between the indoor unit and the outdoor unit are connected, replenish compressed nitrogen to perform airtight test.

**NOTE:**

1. The airtight test is performed by using the compressed nitrogen [2.94MPa (30kg/cm<sup>2</sup>G)].
2. Tighten the spool of the gas valve and liquid valve before compressing the nitrogen.
3. Compress the nitrogen at the air vent of the gas valve.
4. The gas valve and liquid valve are closed in the process of compressing the nitrogen.
5. Do not use oxygen, flammable gas or toxic gas in the airtight test.

### 3.7 Vacuumize

Use a vacuum pump to make a vacuum. Do not use refrigerant gas to expel air. When making the vacuum, start from the air side.

### 3.8 Open All Valves

### 3.9 Additional Charge of Refrigerant

According to the diameter and length of the connective liquid side pipe of the outdoor unit and indoor unit, calculate the refrigerant replenishment quantity. The refrigerant for replenishment is R407C

**Table 2:**

Diameter of liquid line	Quantity of refrigerant replenished for 1m pipe length
Φ12.7	0.115kg
Φ16	0.190kg

### 3.10 Remove Trash and Moist in the Pipe

- Trash and foreign matters may come into the pipe in the process of installing the refrigerant pipe. Be sure to blow them off with nitrogen before connecting the pipe to the outdoor units.
- Use high-pressure nitrogen to clean the pipelines. Do not use the refrigerant of the outdoor unit for cleaning.

### 3.11 Refrigerant Leak Precautions

This air conditioner uses refrigerant R407C. The R407C is safe refrigerant which is harmless and non-flammable. The room for placing the air conditioner should have a proper space. Even if refrigerant leakage occurs, the density threshold will not be crossed. Additional measures may also be taken.

**1) Density threshold:** Density of the Freon gas that does not harm the human body. Density threshold of R407C: 0.3 [kg/m<sup>3</sup>]

- Calculate the total quantity of refrigerant to be replenished (A [kg]). Total refrigerant quantity for 10HP = refrigerant replenishment quantity upon shipment (11[kg]) + additional refrigerant replenishment corresponding to the pipe length
- Calculate out the indoor volume (B [m<sup>3</sup>]) (according to the minimum volume)
- Calculate out the refrigerant density:

$$\frac{A[\text{kg}]}{B[\text{m}^3]} \leq \text{Density threshold: } 0.3 [\text{kg/m}^3]$$

**2) Measures against crossing of the refrigerant density threshold**

- In order to keep the refrigerant density below the threshold value, please install a mechanic ventilation device. (Perform ventilation often)
- In case frequent ventilation is impossible, please install the leakage detection alarm device linked with the mechanical ventilation device.



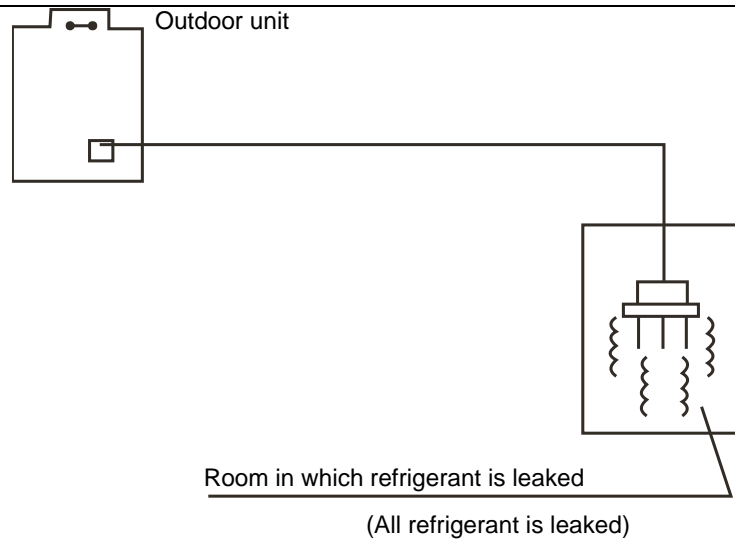

Fig-24

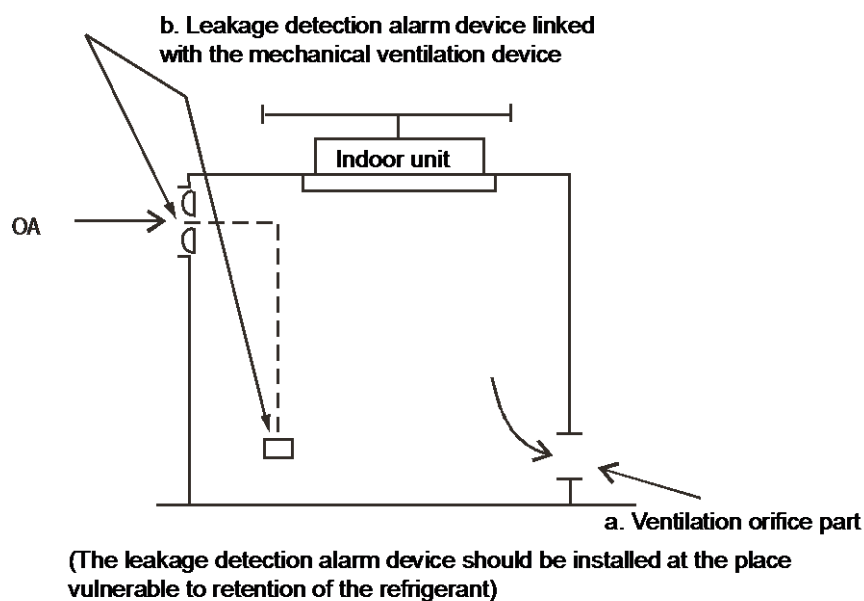

Fig-25

### 3.12 Completing the Connection System Name

In case multiple systems are set, in order to identify the connection system of the indoor unit and outdoor unit, it is necessary to give name to each system, and mark it onto the nameplate on the electric control box cover of the outdoor unit.

**NOTE:**

- The indoor unit and outdoor unit are categorized into system A and system B. When installing and connecting the indoor unit and outdoor unit, identify the label carefully, and make sure that indoor unit corresponds to the outdoor unit exactly. Otherwise, it may lead to fault of the air conditioner.
- Model of indoor unit. Room name  
Example: the first system indoor unit A of the 2<sup>nd</sup> floor is recorded as: 2F 1A.

## 4. Heat Insulation of the Pipe

### 4.1 Heat Insulation of the Pipe

In order to prevent faults caused by condensate of the refrigerant pipe and drain pipe, perform condensate prevention and heat insulation properly.

**CAUTION:**

If it is forecast that high humidity/temperature environment (condensate temperature is over 23°C) may exist in the ceiling, e.g., inside the ceiling with slab, ceiling which is in the same environment as the outdoor air), it is necessary to apply 10mm or thicker adiabatic wool (16~20kg/m<sup>2</sup>) to the refrigerant pipe and the drain pipe in addition to applying the general heat insulation materials. Enough heat insulation materials should also be applied to the refrigerant joint and the pipe joint.

### 4.2 Heat Insulation of the Drain Pipe

- Be sure to entwine heat insulation materials round the drain pipe which runs through the room.
- Carry through heat insulation for the drain pipes thoroughly.

### 4.3 Heat Insulation of the Refrigerant Pipe

- Please use heat-resistant materials as heat insulation materials of the air-side pipe. (e.g., EPT)
- Cover heat insulation materials separately at the liquid side and the air side. Moreover, perform heat insulation thoroughly for the air-side pipes of the indoor unit, and prevent water from dripping outside the unit.

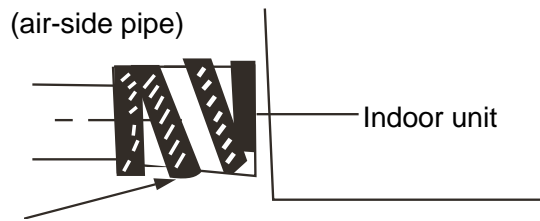

Fig-26

- After applying the auxiliary heat insulation materials, use vinyl resin tape to seal it lest water leak.

## 5. Installation of Connective Pipe

### 5.1 Preparation before Installation

Check the height difference between the indoor unit and the outdoor unit, and check the length and number of bends of the refrigerant pipeline, which must meet the following requirements:

- Max. Height difference....30m (If the height difference is greater than 5m, it is better to put the outdoor unit above the indoor unit).
- Max. Pipeline length.....50m.
- Max. Number of bends....15.
- In the process of installing the connective pipe, do not let the air, dust or foreign substance intrude into the pipeline system.
- Install the connective pipe only after fixing the indoor and outdoor units.
- Keep dry when installing the connective pipe. Do not let moist intrude into the pipeline system.

### 5.2 Procedure of Connecting Pipes

**5.2.1 Measure the required length of the connective pipe, and make the connective pipes in the following procedure.**

**5.2.1.1** Connect the indoor unit first, and then connect the outdoor unit.

The pipe bend should be handled carefully, without damaging the pipe.

**NOTE:**

1. Before screwing up the flared nut, apply refrigerant oil at the outer surface of the pipeline flare and the taper surface of the connection nut. Screw up the nut for 3~4 circles beforehand.
2. When connecting or disconnecting the pipeline, be sure to use two spanners concurrently.
3. Do not rest the weight of the connective pipe on the adapter of the indoor unit. Too heavy load on the adapter of the indoor unit may deform the pipe and thus affect the cooling/heating effect.

**5.2.1.2** The valve of the outdoor unit should be closed completely (as in the factory status). Every time when connecting the pipe, screw off the nut at the valve, and connect the flared pipe (within 5 minutes). If the nut is put away for a long time after being screwed off the valve, dust and other foreign substance may intrude into the pipeline system and lead to fault. Before connecting the pipe, use the refrigerant to expel air out of the pipe.

**5.2.1.3** After the refrigerant pipe is connected to the indoor and outdoor units, expel air as instructed in the "Expel air" section. After expelling the air, screw up the nut at the maintenance orifice.

**5.2.1.4.** Precautions for the flexible part of the pipeline

The bend angle shall not exceed 90°.

The bend shall be preferably in the middle of the pipe length, and higher bend radiuses are preferred. Do not bend the flexible pipe for over 3 times.

**5.2.1.5** Bend the thin-wall connective pipe

When bending the pipe, cut out a notch of the desired size at the bend of the adiabatic pipe, and then expose the pipe (wrap the pipe with the wrapping tape after bending it).

The radio of the elbow pipe should be as large as possible to prevent flattening or crush.

Use the pipe bender to make close elbow pipe.

**5.2.1.6** Use purchased copper pipe

When the copper pipe is purchased from the market, be sure to use the heat insulation materials of the same type (with a thickness of over 9mm).

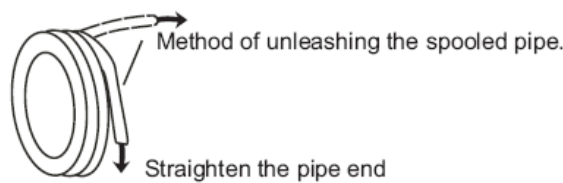
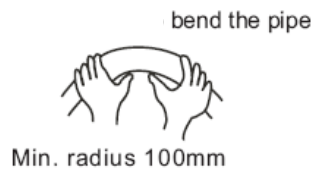
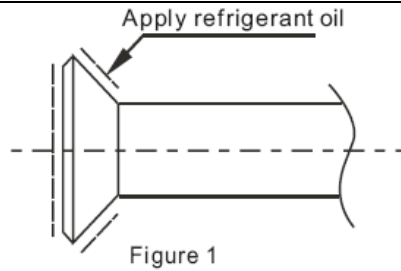

**5.2.2 Deploy the pipelines**

- Drill a porthole on the wall, and put the hole sheath and hole cover through the wall.
- Place the connective pipe together with the indoor & outdoor connection wires. Use wrapping tape to tie them tight. Do not let air penetrate into it lest condensation and drips of moist.
- Pull the connective wrapped connective pipe from outdoor through the sheath which gets through the wall, and lead it into the room. Lay out the pipelines carefully lest damage to the pipes.

**5.2.3. Make a vacuum of connective pipeline.**

**5.2.4. After the above steps are completed, the spool of the valve of the outdoor unit should be completely open, and the refrigerant pipeline of the indoor unit and the outdoor unit should be smooth.**

**5.2.5. Use leak detector or soap water detect leak carefully to prevent leakage.**

**5.2.6. Put on an adiabatic envelope (accessory) at connective pipe adapter of the indoor unit, and wrap it tight with the wrapping tape lest condensate and leakage.**

**• Flare**

- Use a pipe cutter to cut off the pipe.

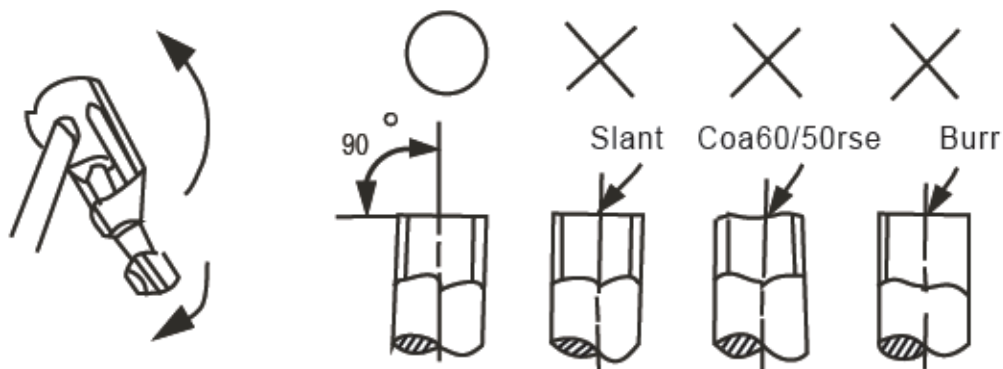

- Pull the pipe into the rear flare of the connective nut.

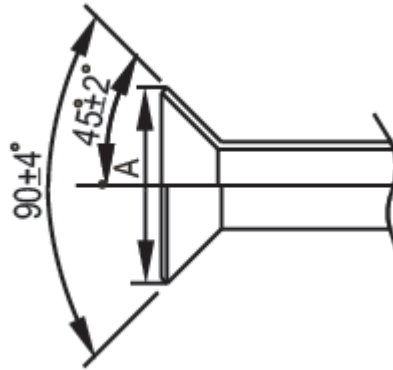

Fig-29

• **Tighten the nut**

Align with the connective pipe

Screw up the connection pipe nut manually, and use a spanner to tighten it as shown in Fig-30

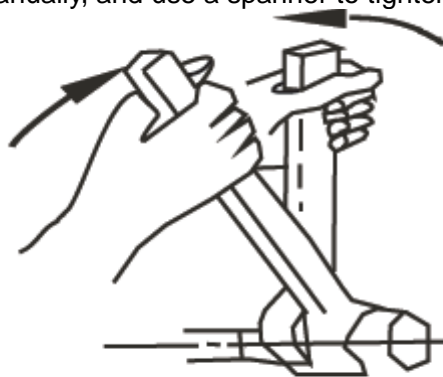

Fig-30

**NOTE:**

According to the installation conditions, too large torque will damage the flaring, and too small torque will lead to looseness and leakage. Determine the tightening torque by reference to the following table.

• **Replenishment quantity of refrigerant required for air conditioner**

The single-pass pipe is shorter than 5 m, and no additional length is required (note: The unit has been replenished before being shipped).

If the single-pass pipe length is 5 m or more, the quantity of fluorine required to be replenished is 0.060X (L-5). (Unit: kg)

Record the replenishment quantity of the refrigerant and keep the record properly for reference in future maintenance.

**Table 3:**

Pipe diameter	Torque
φ 6.35	1420~1720N.cm (144~176kgf.cm)
φ 9.53	3270~3990N.cm (333~407kgf.cm)
φ 12.7	4950~6030N.cm (504~616kgf.cm)
φ 16.0	6180~7540N.cm (630~770kgf.cm)
φ 19.0	9720~11860N.cm (990~1210kgf.cm)

### 5.3 Expelling Air

5.3.1. From the following table, select a method of expelling air.

Table 4:

Length of connective pipe (single pass)	Procedure of expelling air
Less than 5m	Use refrigerant in the outdoor unit
5~15m	Use vacuum pump or refrigerant tank.

If the air conditioner is relocated, be sure to use a vacuum pump or refrigerant tank to expel air.

5.3.1.2. Use the refrigerant in the outdoor unit to expel air (see Fig-31 and Fig-32)

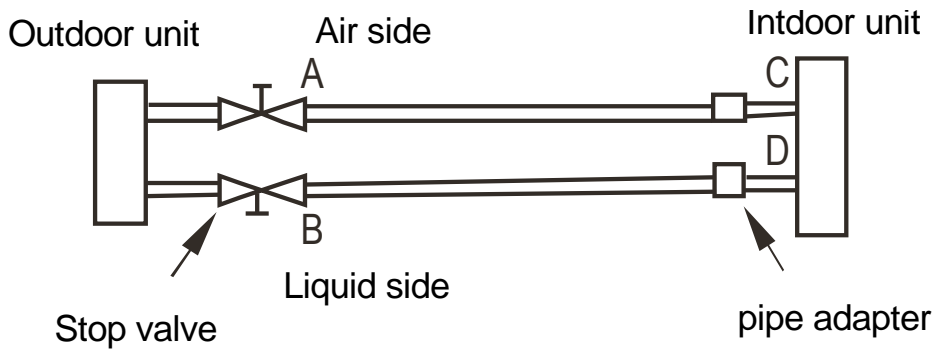

Fig-31

- Screw up the pipe nuts at A, B, C and D completely.
- Loosen and remove the square-head cover of valves A and B, rotate the square-head spool of valve B counterclockwise for 45 degrees and stay for about 10 seconds, and then close the spool of valve B tightly.
- Detect leak for all adapters at A, B, C and D. After making sure that no leak exists, open the maintenance orifice nut of valve A. After all air is expelled, tighten the maintenance orifice nut of valve A.
- Open the spools of valves A and B completely.
- Tighten the square-head cover of valves A and B completely.

5.3.1.3. Use refrigerant tank to expel air (see Fig-31)

- Screw up the pipe nuts at A, B, C and D completely.
- Loosen and remove the square-head cover and the maintenance orifice nut of valves A and B.
- Connect the filler hose of the refrigerant tank with the maintenance orifice of valve A.
- Loosen the valve of the refrigerant tank, continue filling refrigerant for 6 seconds to expel the air, and tighten the nut of valve B quickly.
- Loosen the valve of the refrigerant tank again, and fill the refrigerant for 6 seconds. Detect leak for all adapters at A, B, C and D. After making sure that no leak exists, screw off the filler hose. After all the filled refrigerant is expelled, screw up the maintenance orifice nut of valve A quickly.
- Open the square-head spools of valves A and B completely.
- Tighten the square-head cover of valves A and B.

5.3.1.4. Use a vacuum pump to expel the air (Fig-32) (For method of using the manifold valve, see the operation manual of manifold valve):

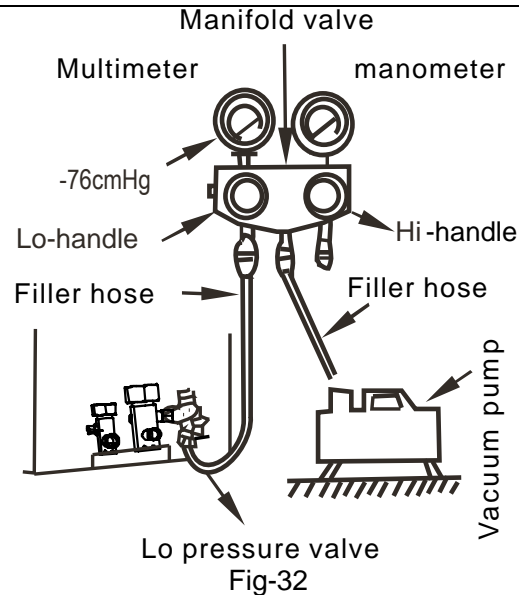

- Loosen and remove the maintenance orifice nut of valve A, and connect the filler hose of the manifold valve to the maintenance orifice of valve A (tighten both valve A and valve B).
- Connect the filler hose adapter to the vacuum pump.
- Open the low pressure (Lo) handle of the manifold valve completely.
- Start the vacuum pump to extract air. At the beginning of extracting air, slightly loosen the maintenance orifice nut of valve B, check whether any air enters it (the vacuum pump noise changes and the multi-meter indicate from negative to 0). Then tighten this maintenance orifice nut.
- Upon completion of vacuuming, tighten the low pressure (Lo) handle of the manifold valve completely and stop the vacuum pump. Keep extracting air for over 15 minutes. Check whether the multi-meter points at  $-1.0 \times 10^5$  Pa (-76cmHg).
- Loosen and remove the square-head cover of valves A and B. After opening valves A and B completely, tighten the square head cover of valves A and B.
- Remove the filler hose off the maintenance orifice of valve A, and then tighten the nut.

#### 5.3.1.5. Procedure of using stop valve

- Open the spool until it touches the stop block. Do not attempt to open further.
- Use a spanner or a similar tool to tighten the bonnet. The bonnet tightening torque is shown in Table 3 "Tightening torque".
- Upon completion of installation, open all valves before trial run. Each unit has two valves of different sizes located at the outdoor unit side. Of the two valves, one is gas valve and the other is liquid valve. The procedure of opening/closing the valve is shown in the right figure (Fig-33).
- Procedure of opening the valve: Open the square-head cover, use a spanner to capture the square head and open it thoroughly. Then tighten the square-head cover.
- Procedure of closing the valve: Same as the procedure of opening the valve, but rotate the spanner clockwise thoroughly.

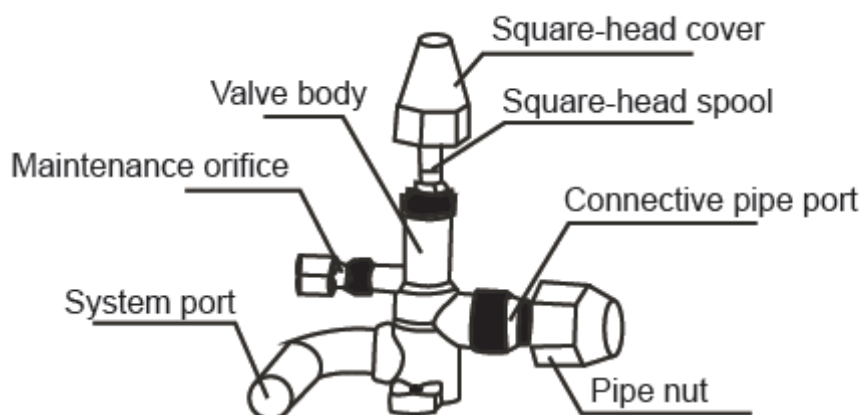

### 5.4 Leak Detection

Use soap water or a leak detector to check whether gas leakage exists at the adapters.

### 5.5 Heat Insulation

- Use heat insulation materials to wrap the part protruding outside the flared pipe joint and the refrigerant pipe of the liquid pipe and the gas pipe, and ensure that no gap exists between them.
- Imperfect heat insulation may lead to condensate drips.

## 6. Installation of Drain Pipe

### 6.1 Install the drain pipe of the indoor unit

- In order to prevent drain overflow, install a drainage controller at place 1 of the drain pipe. (The drainage controller is designed to smoothen the drainage when the static pressure outside the unit is high, especially at the air inlet, in addition to remove stink through the drain pipe.)
- The drain of water is natural. In the construction, the external pipe of the outdoor unit slants downward at a gradient of 1/50~1/100.
- The number of bends and folds of the drain pipe should not exceed 2. Try to avoid bends in order to prevent trash accumulation.
- In the construction, do not drop trash into the drip tray or drain pipe of the indoor unit.
- Upon completion of installing the drain pipe, remove the inspection panel. Put water into the drip tray to check whether the water can be drained levelly and steadily.

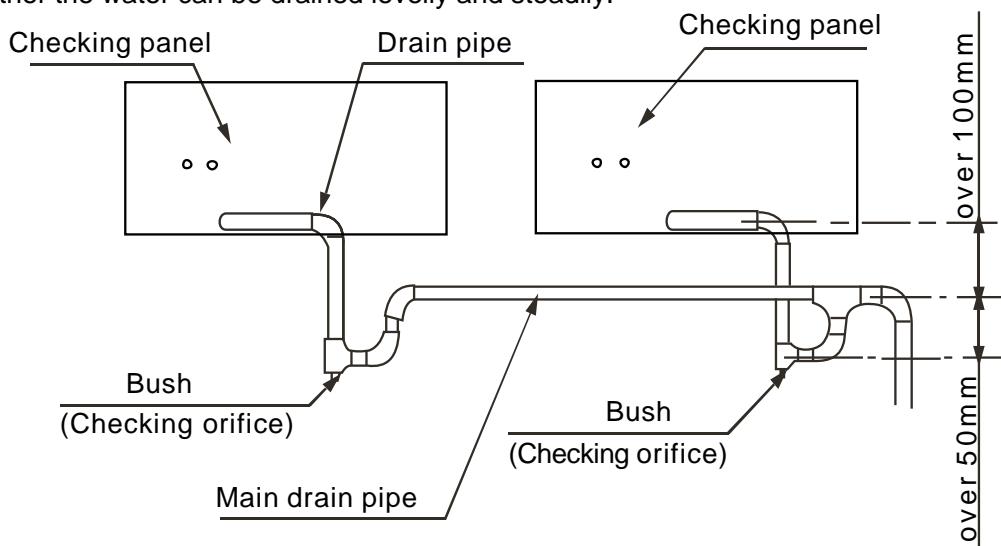

Fig-34

**NOTE:**

Drain pipe trash gains easily at the drainage controller. Be sure to install a stopper and a structure that cleans up trash easily.

### 6.2. Trial draining of the drain pipe

Open the side panels of the indoor unit, fill water inward, and check whether the water can be drained smoothly. Check water leak at the joint.

### 6.3. Heat insulation of drain pipe

After making sure that the water drains smoothly and no water is leaked, use adiabatic wool bushes to preserve heat of the drain pipe. Otherwise, condensate will occur.



## 7. Electric Connection

### 7.1 Electric field wiring

**CAUTION:**

- Use special power supply for the air conditioner. Design power supplies specific to the indoor unit and outdoor unit. The supply voltage must comply with the nominal voltage.
- The external supply circuit of the air conditioner must have a ground wire, and the power supply ground wire of the indoor unit must be connected with the external ground wire firmly.
- The wiring must be performed by professional technicians according to the circuit diagram labels.
- Distribute the wires according to the relevant electric technical standards promulgated by the State, and set the Residual Current-operated Circuit Breaker (RCCB) properly.
- The power wire and the signal wire shall be laid out neatly and properly, without mutual interference or contacting the connection pipe or valve.
- No power cable is attached to this equipment. The user can select the power cable by reference to the stipulated power supply specifications. No joint of wires is allowed.
- Upon completion of wire connection, double check it and then connect the power supply.

Duct type- cooling only: 76 kBTu/h; 96 kBTu/h; 120 kBTu/h,

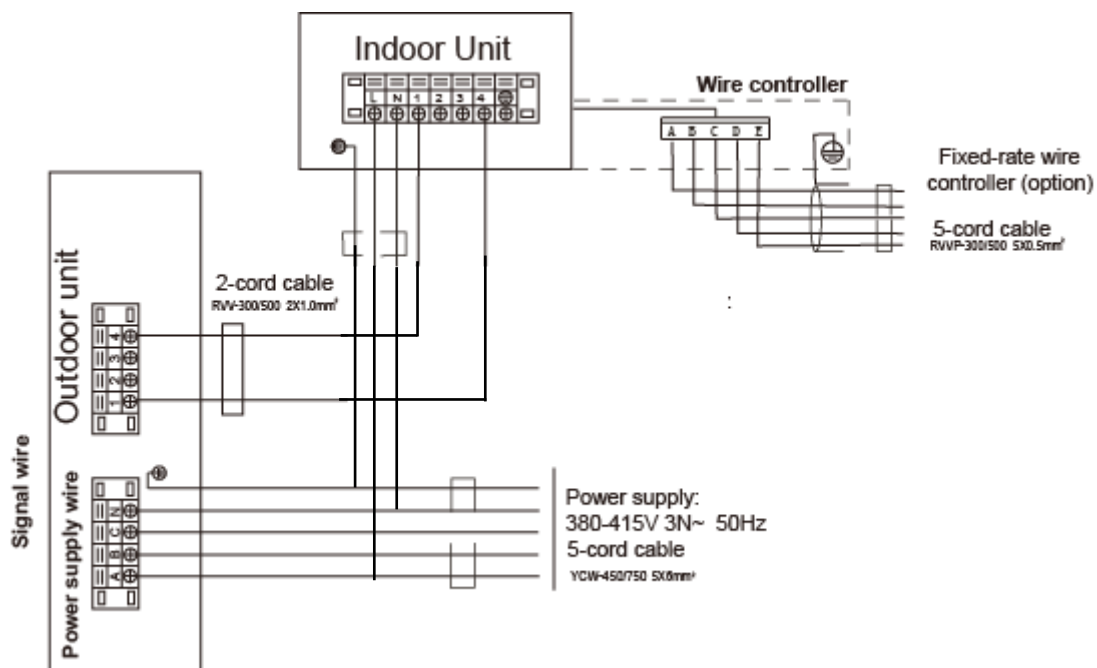

Duct type- cooling and heating type: 76 kBTu/h; 96 kBTu/h; 120 kBTu/h,

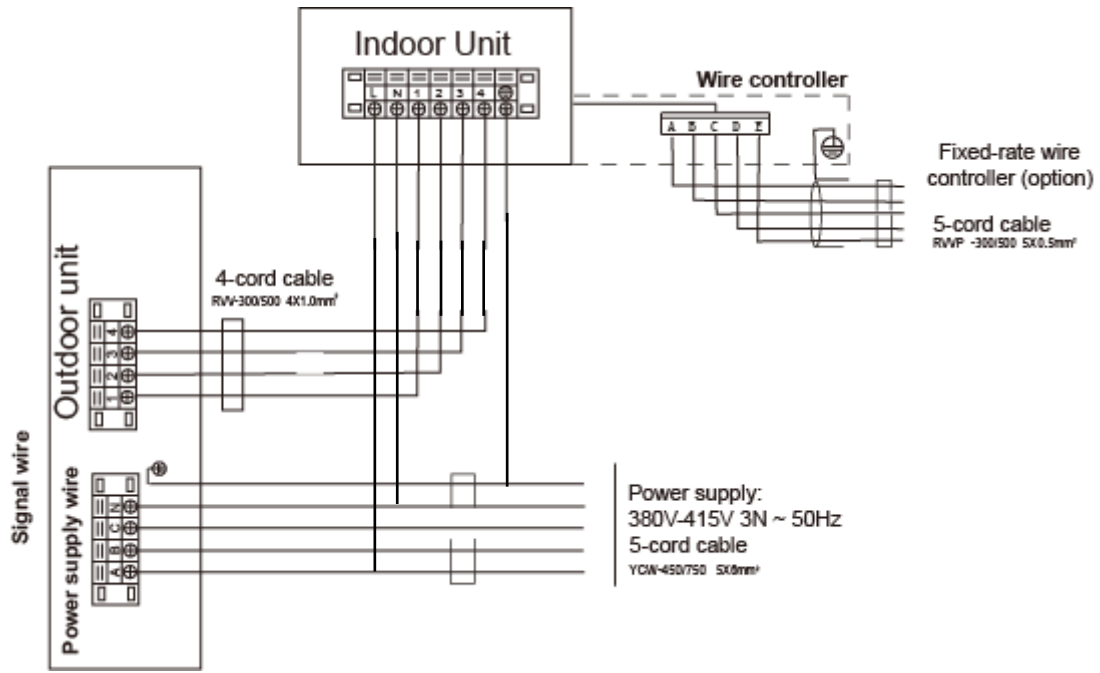

Floor standing type- cooling only: 76 kBTu/h; 96 kBTu/h,

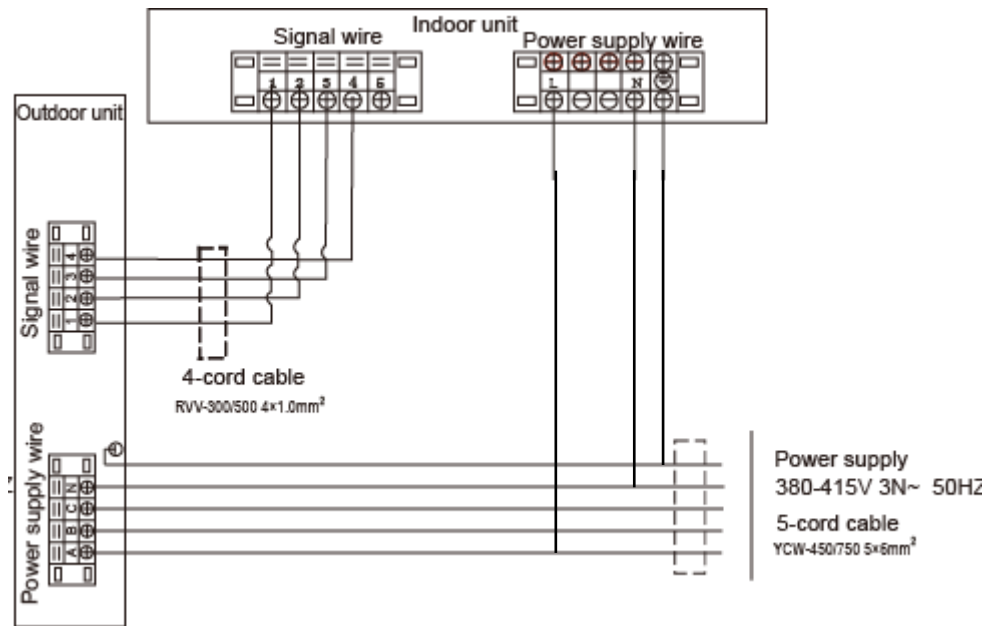

Floor standing type- cooling and heating type:76 kBTu/h; 96 kBTu/h,

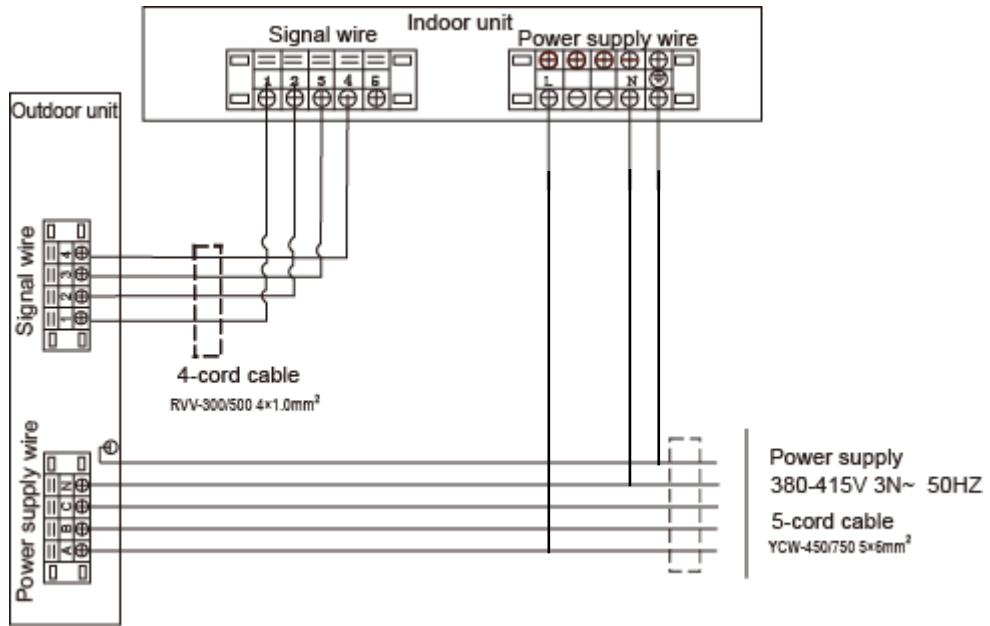

**Appendix 1: Indoor Temp. and Pipe Temp. Sensor Resistance Value Table (°C--K)**

°C	K Ohm	°C	K Ohm	°C	K Ohm	°C	K Ohm
-20	115.266	20	12.6431	60	2.35774	100	0.62973
-19	108.146	21	12.0561	61	2.27249	101	0.61148
-18	101.517	22	11.5000	62	2.19073	102	0.59386
-17	96.3423	23	10.9731	63	2.11241	103	0.57683
-16	89.5865	24	10.4736	64	2.03732	104	0.56038
-15	84.2190	25	10.0000	65	1.96532	105	0.54448
-14	79.3110	26	9.55074	66	1.89627	106	0.52912
-13	74.5360	27	9.12445	67	1.83003	107	0.51426
-12	70.1698	28	8.71983	68	1.76647	108	0.49989
-11	66.0898	29	8.33566	69	1.70547	109	0.48600
-10	62.2756	30	7.97078	70	1.64691	110	0.47256
-9	58.7079	31	7.62411	71	1.59068	111	0.45957
-8	56.3694	32	7.29464	72	1.53668	112	0.44699
-7	52.2438	33	6.98142	73	1.48481	113	0.43482
-6	49.3161	34	6.68355	74	1.43498	114	0.42304
-5	46.5725	35	6.40021	75	1.38703	115	0.41164
-4	44.0000	36	6.13059	76	1.34105	116	0.40060
-3	41.5878	37	5.87359	77	1.29078	117	0.38991
-2	39.8239	38	5.62961	78	1.25423	118	0.37956
-1	37.1988	39	5.39689	79	1.21330	119	0.36954
0	35.2024	40	5.17519	80	1.17393	120	0.35982
1	33.3269	41	4.96392	81	1.13604	121	0.35042
2	31.5635	42	4.76253	82	1.09958	122	0.3413
3	29.9058	43	4.57050	83	1.06448	123	0.33246
4	28.3459	44	4.38736	84	1.03069	124	0.32390
5	26.8778	45	4.21263	85	0.99815	125	0.31559
6	25.4954	46	4.04589	86	0.96681	126	0.30754
7	24.1932	47	3.88673	87	0.93662	127	0.29974
8	22.5662	48	3.73476	88	0.90753	128	0.29216
9	21.8094	49	3.58962	89	0.87950	129	0.28482
10	20.7184	50	3.45097	90	0.85248	130	0.27770
11	19.6891	51	3.31847	91	0.82643	131	0.27078
12	18.7177	52	3.19183	92	0.80132	132	0.26408
13	17.8005	53	3.07075	93	0.77709	133	0.25757
14	16.9341	54	2.95896	94	0.75373	134	0.25125
15	16.1156	55	2.84421	95	0.73119	135	0.24512
16	15.3418	56	2.73823	96	0.70944	136	0.23916
17	14.6181	57	2.63682	97	0.68844	137	0.23338
18	13.9180	58	2.53973	98	0.66818	138	0.22776
19	13.2631	59	2.44677	99	0.64862	139	0.22231