

# DC INVERTER SERIES

Service Manual 2012

LIS-B-1201

---

**Part 1**

**General Information.....1**

**Part 2**

**Indoor Units.....7**

**Part 3**

**Outdoor Units.....42**

**Part 4**

**Installation.....80**

**Part 5**

**Control.....91**

⊗The specifications, designs, and information in this book are subject to change without notice for product improvement.

## **Part 1 General Information**

<a href="#"><u>1.Model Lists.....</u></a>	<a href="#"><u>2</u></a>
<a href="#"><u>2.External Appearance.....</u></a>	<a href="#"><u>3</u></a>
<a href="#"><u>3.Nomenclature.....</u></a>	<a href="#"><u>4</u></a>
<a href="#"><u>4.Features.....</u></a>	<a href="#"><u>6</u></a>



## 1. Model Lists

### 1.1 Indoor Units

R410A		Capacity multiplied by 1000Btu/h						
Type	Function	12	18	24	30	36	48	60
New Four-way cassette (compact)	Cooling and heating	●	●					
Four-way cassette	Cooling and heating			●	●	●	●	●
Ceiling & floor	Cooling and heating	●	●	●	●	●	●	●
Duct	Cooling and heating	●	●	●	●	●	●	●
Console	Cooling and heating	●	●					
High static pressure duct	Cooling and heating					●	●	●

### 1.2 Outdoor Units

Universal Outdoor unit Model	Compressor type	Compressor Brand	Matched indoor units
MOU-12HDN1-Q	Rotary DC Inverter	GMCC	MCA2-12HRDN1-Q MFA-12HRDN1-Q MUB-12HRDN1-Q MTB1-12HWDN1-Q
MOU-18HDN1-Q	Scroll DC Inverter	GMCC	MCA2-18HRDN1-Q MFA-18HRDN1-Q MUB-18HRDN1-Q MTB-18HWDN1-Q
MOU-24HDN1-Q	Rotary DC Inverter	GMCC	MCC-24HRDN1-Q MUB-24HRDN1-Q MTB-24HWDN1-Q
MOU-30HDN1-Q	Rotary DC Inverter	MITSUBISHI	MCC-30HRDN1-Q MUB-30HRDN1-Q MTB-30HWDN1-Q
MOU-36HDN1-Q	Rotary DC Inverter	MITSUBISHI	MCC-36HRDN1-Q MUB-36HRDN1-Q MTB-36HWDN1-Q MHD-36HRDN1-Q
MOU-36HDN1-Q	Rotary DC Inverter	GUANGZHOU MITSUBISHI	MCC-36HRDN1-Q MUB-36HRDN1-Q MTB-36HWDN1-Q MHD-36HRDN1-Q
MOU-36HDN1-R	Rotary DC Inverter	GUANGZHOU MITSUBISHI	MCC-36HRDN1-Q MUB-36HRDN1-Q MTB-36HWDN1-Q MHD-36HRDN1-Q
MOU-48HDN1-Q	Rotary DC Inverter	GUANGZHOU MITSUBISHI	MCC-48HRDN1-Q MUB-48HRDN1-Q MTB-48HWDN1-Q MHD-48HRDN1-Q
MOU-48HDN1-R	Rotary DC Inverter	GUANGZHOU MITSUBISHI	MCC-48HRDN1-Q MUB-48HRDN1-Q MTB-48HWDN1-Q MHD-48HRDN1-Q
MOU-60HDN1-R	Rotary DC Inverter	GUANGZHOU MITSUBISHI	MCC-60HRDN1-R MUB-60HRDN1-R MTB-60HWDN1-R MHD-60HRDN1-R

## 2. External Appearance

### 2.1 Indoor Units

Duct



Compact Four-way cassette



Four-way Cassette



### 2.2 Outdoor Units



Single fan outdoor unit

Double fan outdoor unit

### 3. Nomenclature

#### 3.1 Indoor Unit

**M U B T - 36 H R D N1 - R**

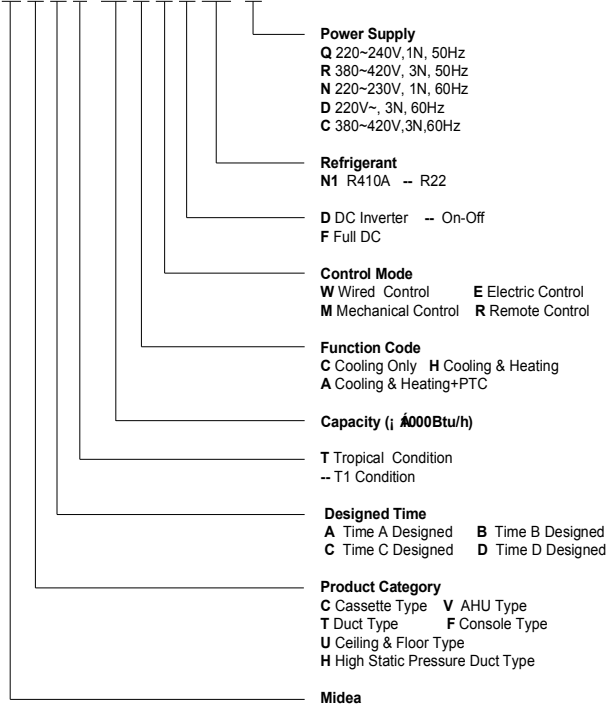

### 3.2 Outdoor Unit

**M O U T- 36 H D N1- R**

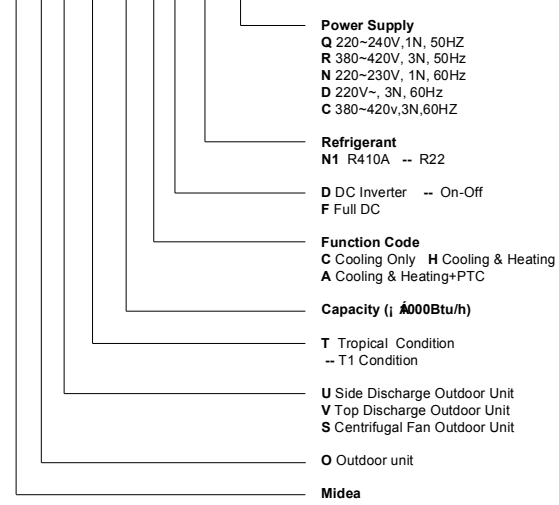

## **4. Features**

### 4.1 Universal outdoor unit design

Indoor unit with the same capacity can match with the same outdoor unit.

### 4.2 High efficiency and energy saving.

Thanks to the DC inverter technology and optimized piping system, the EER and COP of whole series can easily reach A-class.

### 4.3 Full range of products from 12K to 60K, including Med duct(A5), cassette, console, ceiling and floor, more choice for you

### 4.4 Low ambient kit is standard for outdoor units (except 12K)

### 4.5 Network control function is standard for the indoor units (except 12K)

### 4.6 Standard auto restart function and follow me function

### 4.7 Cassette, ceiling & floor, console and compact cassette with standard remote controller, wire controller and CCM for optional. Med Duct with standard wired controller, remote controller and CCM for optional.

### 4.8 Standard anti-cold air function

### 4.9 Standard auto defrosting function

### 4.10 Standard self-diagnose function.

### 4.11 Standard timer function and sleep mode function controlled by controller.

**Part 2**  
**Indoor Units**

[New Four-way Cassette Type \(Compact\).....8](#)

[Four-way Cassette Type .....19](#)

[Duct Type.....27](#)

## New Four-way Cassette Type (Compact)

<b><u>1.Features.....</u></b>	<b><u>9</u></b>
<b><u>2.Dimensions.....</u></b>	<b><u>11</u></b>
<b><u>3.Service Space .....</u></b>	<b><u>11</u></b>
<b><u>4.Wiring Diagrams.....</u></b>	<b><u>13</u></b>
<b><u>5.Air Velocity and Temperature Distributions.....</u></b>	<b><u>14</u></b>
<b><u>6.Electric Characteristics.....</u></b>	<b><u>14</u></b>
<b><u>7.Sound Levels.....</u></b>	<b><u>15</u></b>
<b><u>8.Accessories .....</u></b>	<b><u>16</u></b>
<b><u>9.The Specification of Power .....</u></b>	<b><u>16</u></b>
<b><u>10.Field Wiring .....</u></b>	<b><u>17</u></b>

## 1. Features

### 1.1 New panel

- 360°surrounding air outlet design, affords comfortable feeling



### 1.2 Compact design

- The body size is 570×260×570mm, it's just smaller than the ceiling board, so it's very easy for installation and will not damage the decoration. The panel size is 647×50×647mm.
- The hooks are designed in the four corners of the body, which can save installation space.



### 1.3 Electric control box built-in design

- The E-box is simply and safely built inside the indoor unit. It's convenient for installation and maintenance. Can check the control part easily, you only need to open the air return grille.



### 1.4 Fresh air intake function:

- Fresh air fulfills air quality more healthy and comfortable.



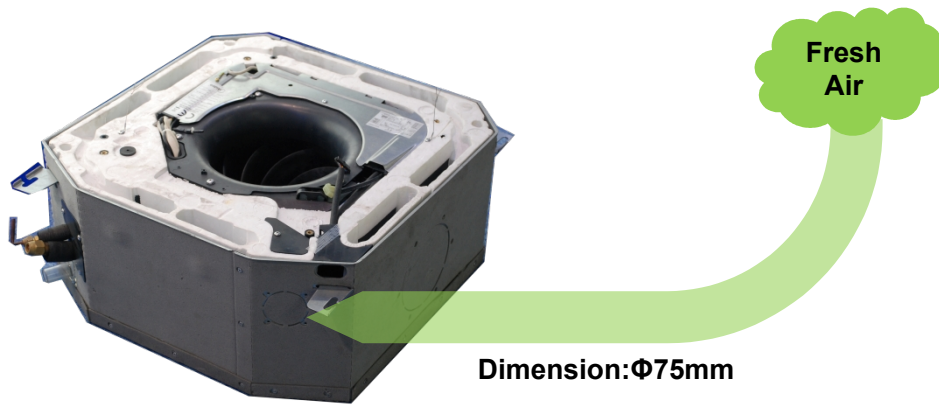

### 1.5 Air passage function

- Reserves the space for air outlet from the side of indoor unit; It's availed to connect air duct from the two sides to the nearby small rooms.

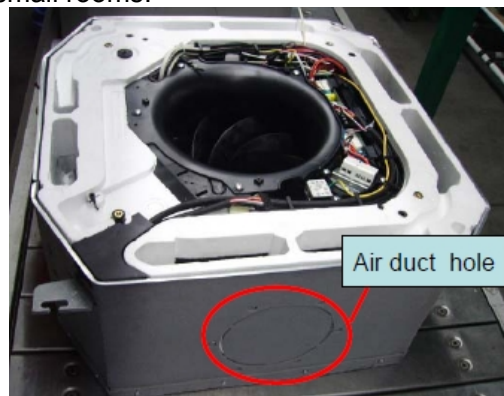

## 2. Dimensions

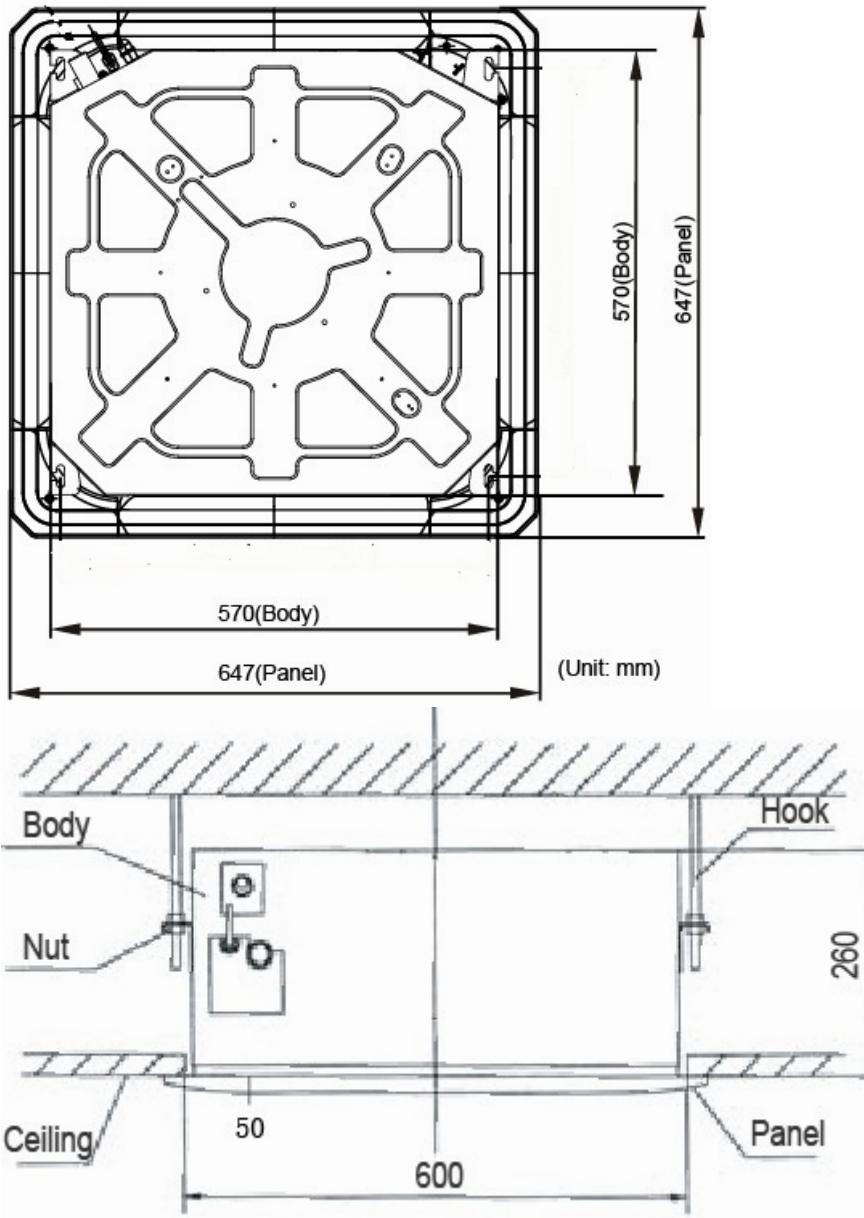

## 3. Service Space

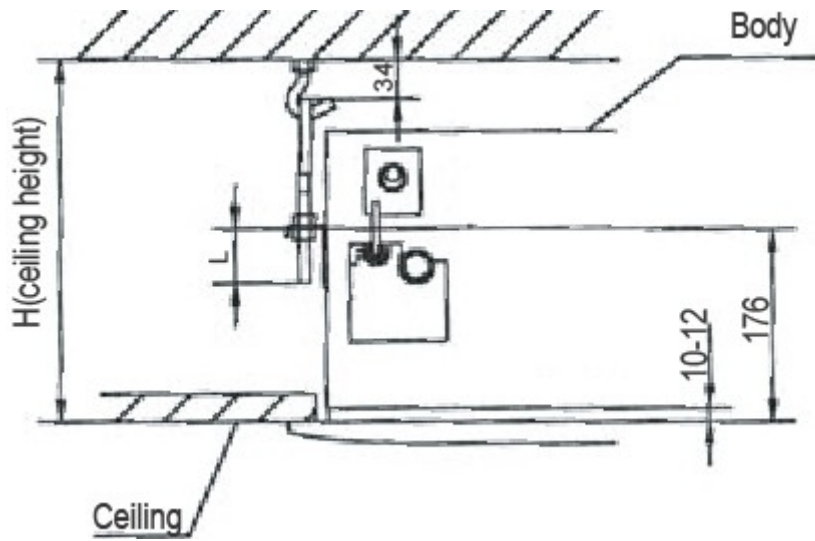
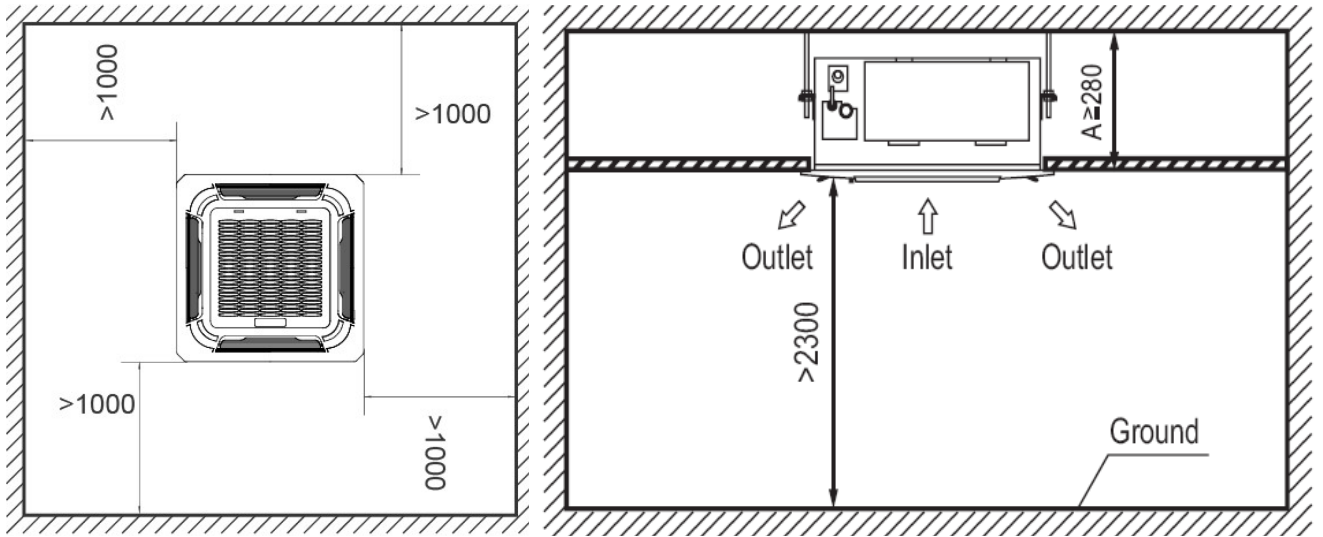

### 4. Wiring Diagrams MCA2-12HRDN1-Q

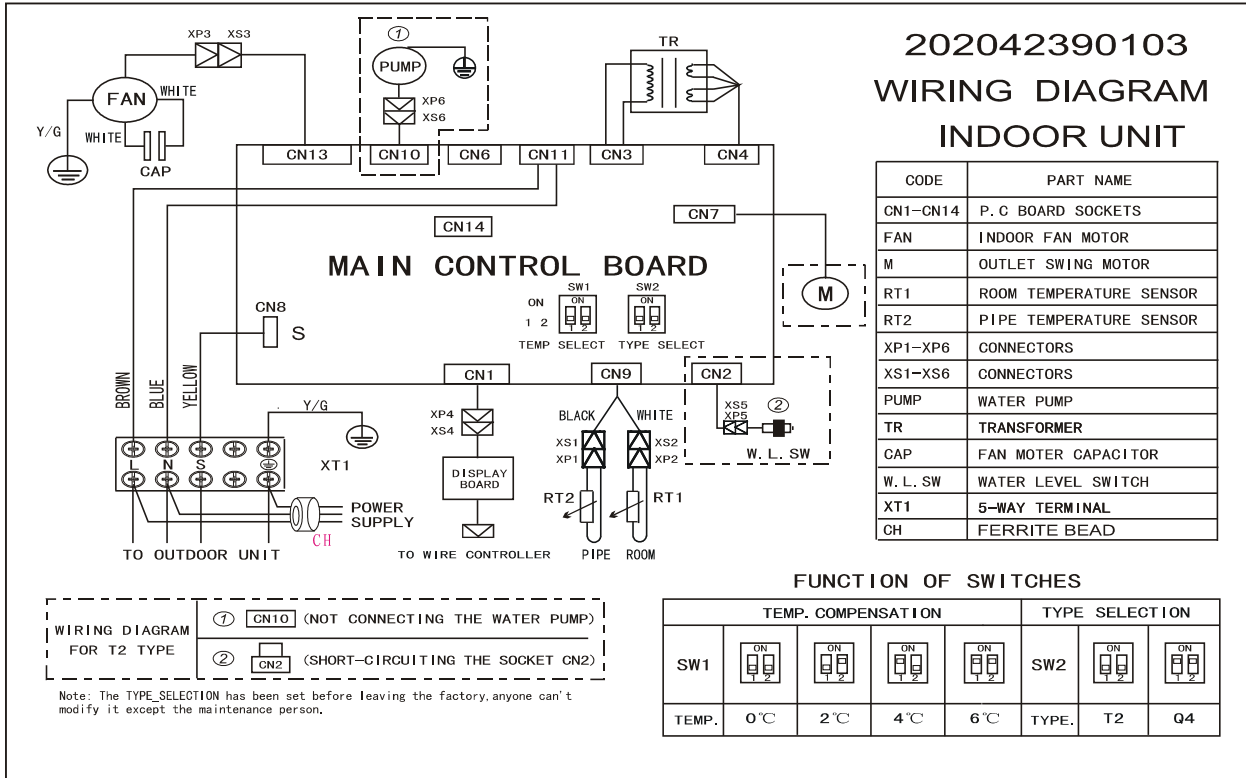

### MCA2-18HRDN1-Q

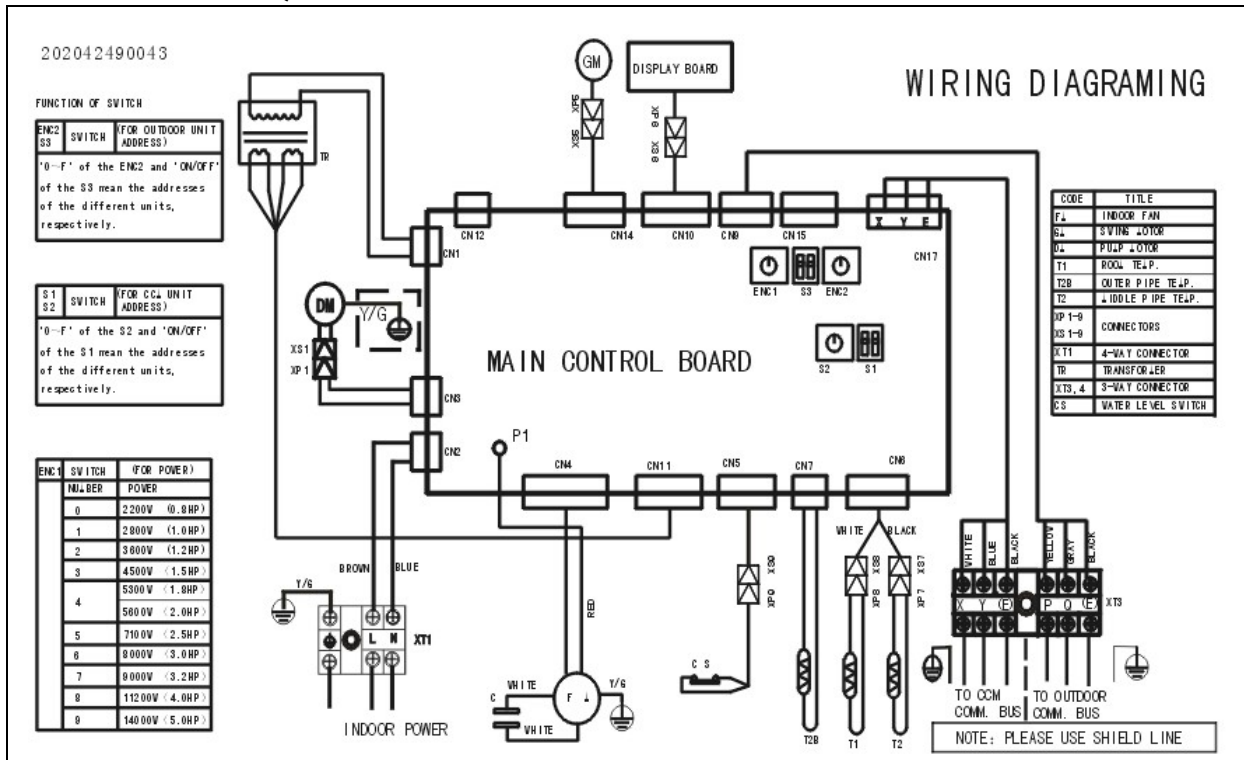

## 5. Air Velocity and Temperature Distributions

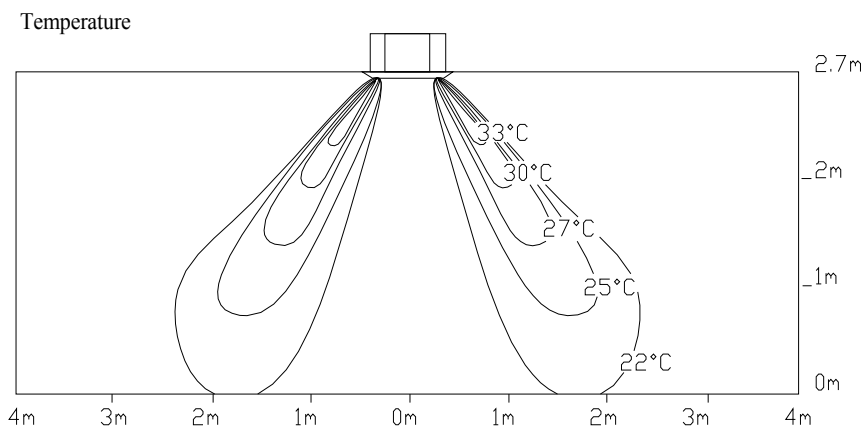
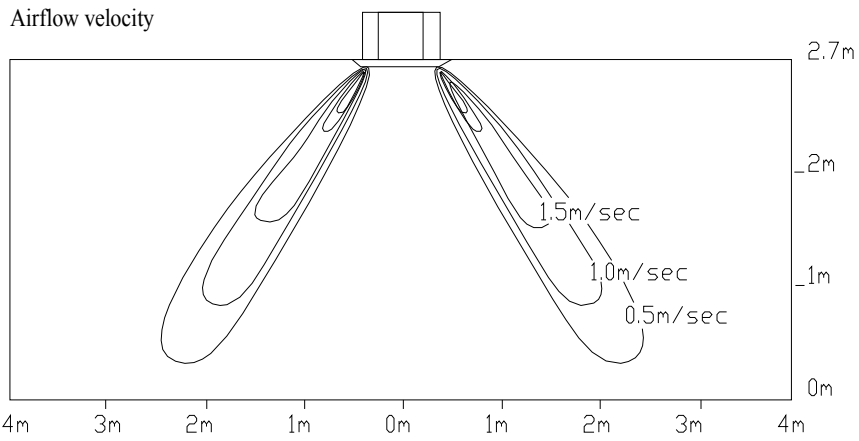

## 6. Electric Characteristics

Model	Indoor Units				Power Supply
	Hz	MFA	Min.	Max.	MFA
MCA2-12HRDN1-Q	50	220-240V	198V	254V	20
MCA2-18HRDN1-Q	50	220-240V	198V	254V	15





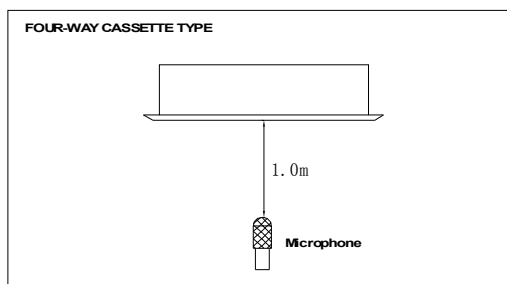



**Notes:**

MFA: Max. Fuse Amps. (A)

**7. Sound Levels**

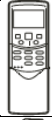
Model	Noise level dB(A)		
	H	M	L
MCA2-12HRDN1-Q	42	41	38
MCA2-18HRDN1-Q	42	41	38

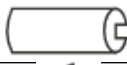
## 8. Accessories

	Name	Shape	Quantity
Installation fittings			
	3. Installation paper board		1
Drainpipe Fittings	4. Out-let pipe sheath		1
	5. Out-let pipe clasp		1
	6. Tightening band		20
	7. Drain joint		1
Remote controller & Its holder	8. Remote controller		1
	9. Remote controller holder		1
	10. Mounting screw(ST2.9×10-C-H)		2
	11. Alkaline dry batteries (AM4)		2
Others	12. Owner's manual		1
	13. Installation manual		1

## 9. The Specification of Power

Model		12000Btu/h	18000 Btu/h
INDOOR UNIT POWER	Phase	1-phase	1-phase
	Frequency and Voltage	220-240V, 50Hz	220-240V, 50Hz
	POWER WIRING (mm <sup>2</sup> )	3×2.5	3×1.0
	CIRCUIT BREAKER (A)	20	15
OUTDOOR UNIT POWER	Phase	—————	1-phase
	Frequency and Voltage	—————	220-240V, 50Hz
	POWER WIRING (mm <sup>2</sup> )	—————	3×2.5
	CIRCUIT BREAKER (A)	—————	30
Indoor/Outdoor Connecting Wiring (Weak Electric Signal) (mm <sup>2</sup> )		—————	3×0.5
Indoor/Outdoor Connecting Wiring (Strong Electric Signal) (mm <sup>2</sup> )		4×2.5	—————

## 10. Field Wiring

### MCA2-12HRDN1-Q

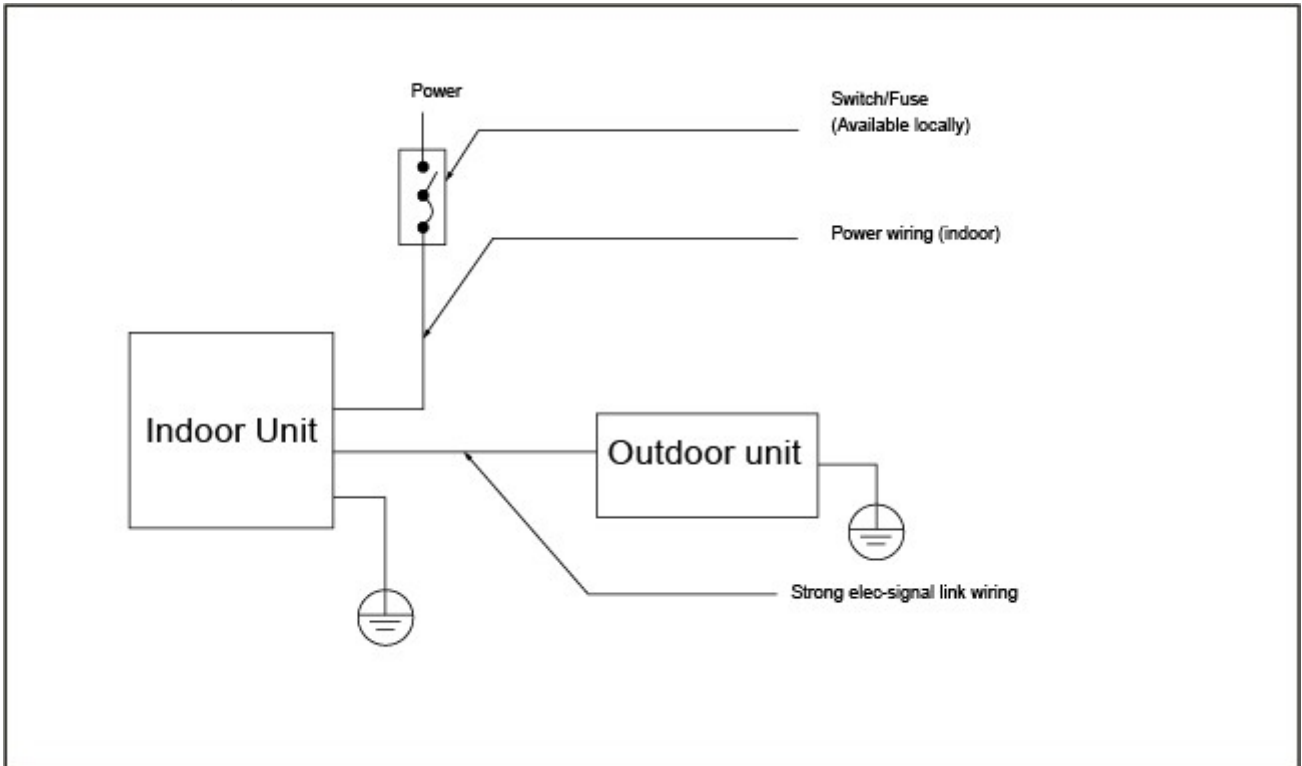

### MCA2-18HRDN1-Q

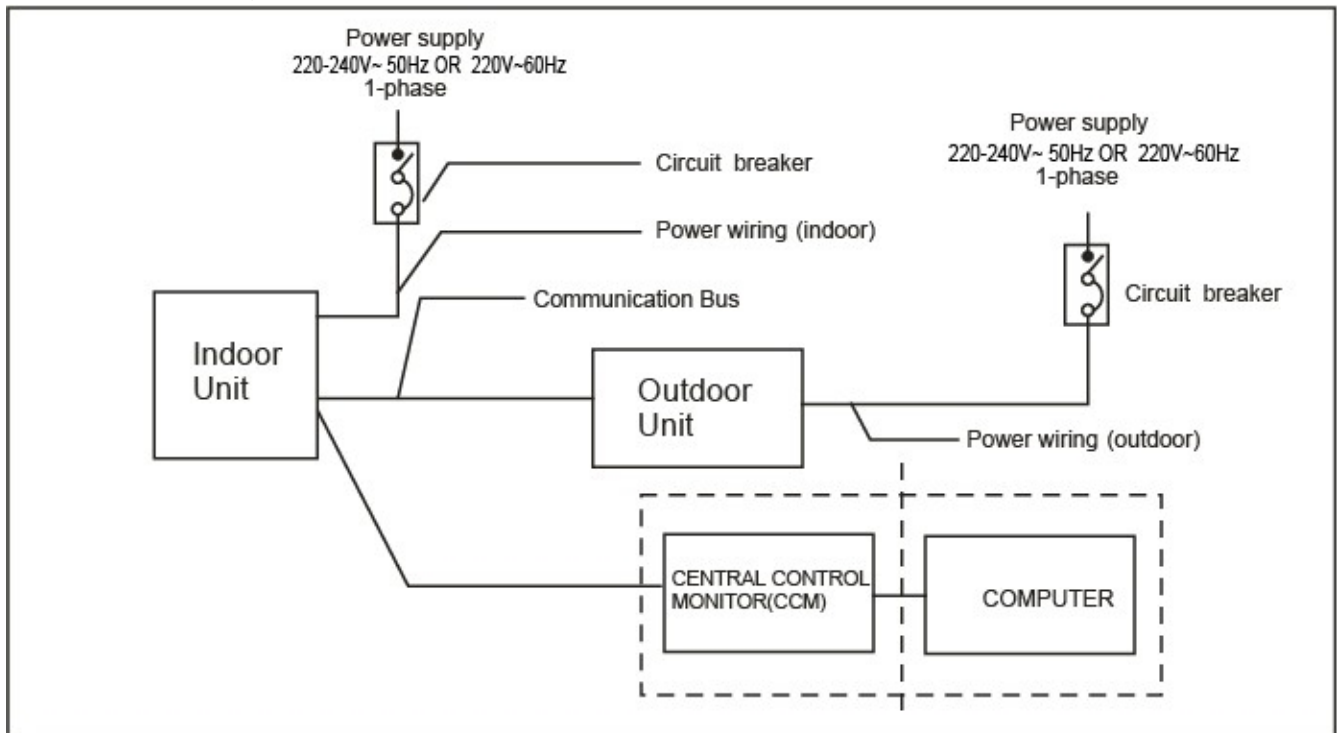



**MCA2-12HRDN1-Q**

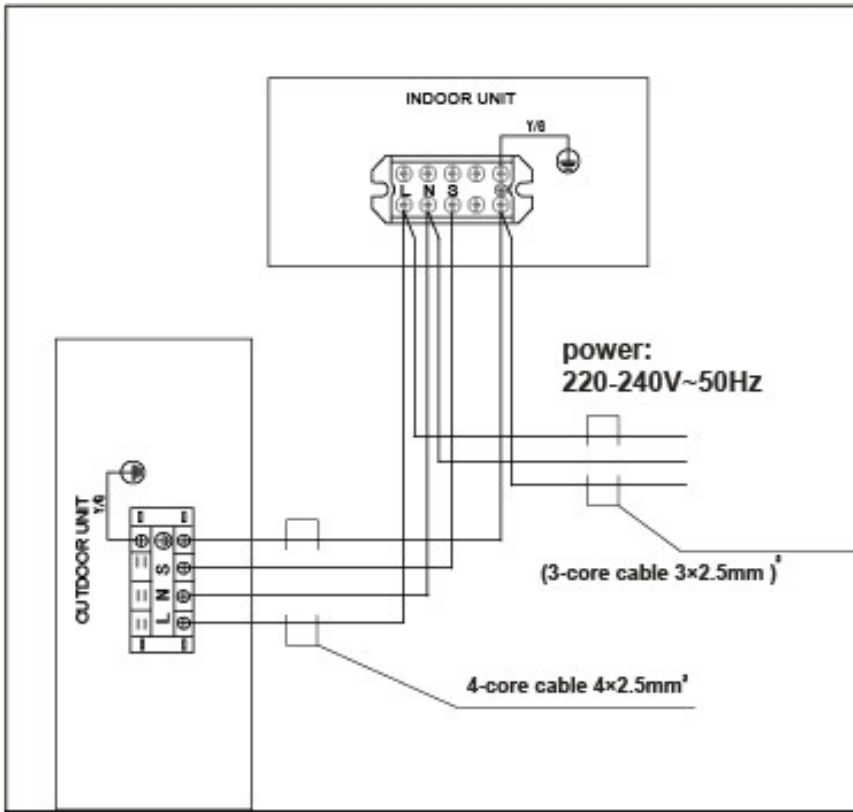

**MCA2-18HRDN1-Q**

**Air Condition Link-Circuit**

202042890198

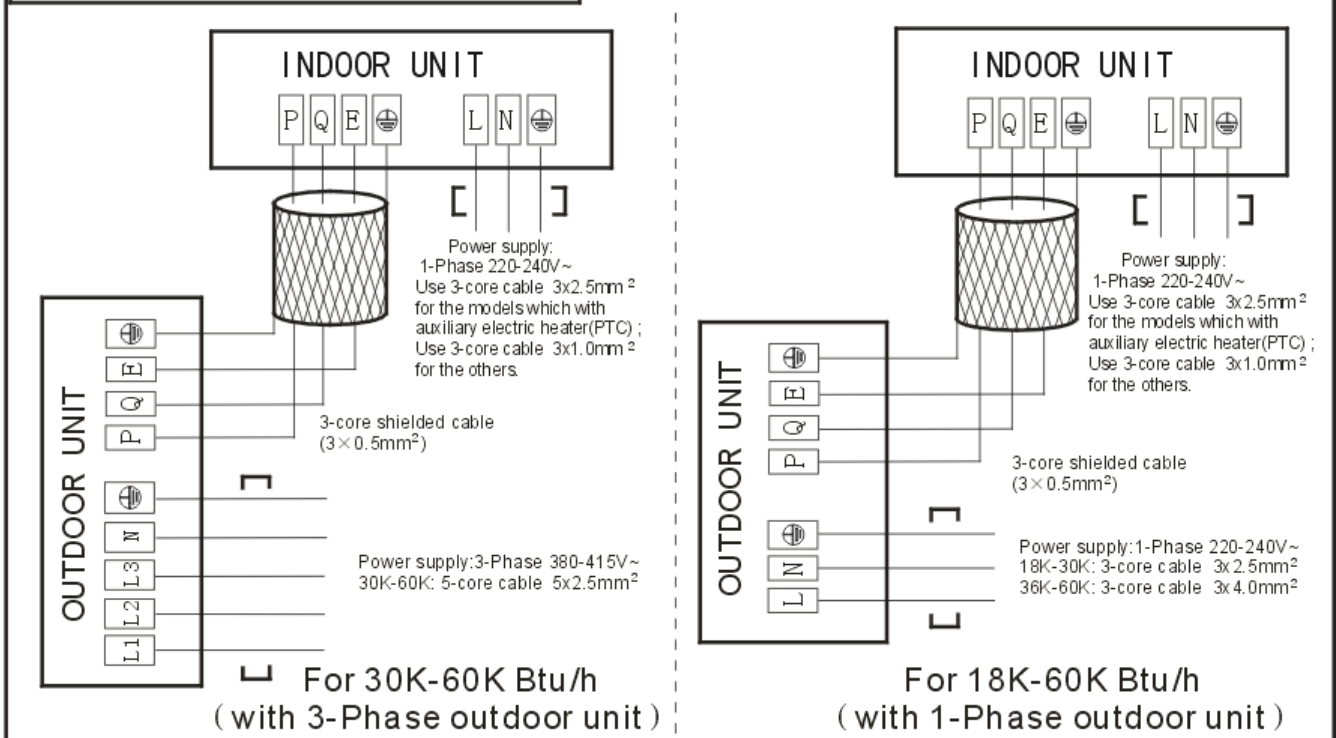

---

## Four-way Cassette Type

<b><u>1.Features.....</u></b>	<b><u>21</u></b>
<b><u>2.Dimensions.....</u></b>	<b><u>25</u></b>
<b><u>3.Service Space.....</u></b>	<b><u>25</u></b>
<b><u>4.Wiring Diagrams.....</u></b>	<b><u>27</u></b>
<b><u>5. Air Velocity and Temperature Distributions.....</u></b>	<b><u>22</u></b>
<b><u>6.Electric Characteristics.....</u></b>	<b><u>23</u></b>
<b><u>7.Sound Levels.....</u></b>	<b><u>23</u></b>
<b><u>8.Accessories .....</u></b>	<b><u>24</u></b>
<b><u>9.The Specification of Power.....</u></b>	<b><u>25</u></b>
<b><u>10.Field Wiring .....</u></b>	<b><u>26</u></b>

## 1. Features

### 1.1 New panel(Front )

- New panel with 360° airflow supply
- Air intake grille lift function for super thin cassette, convenient for maintenance.



### 1.2 New panel(Back)

- Four swing motors, wide swing angel.
- Four motors drive each air louver, fulfill more well-proportioned airflow organization to afford the best comfortable feeling.

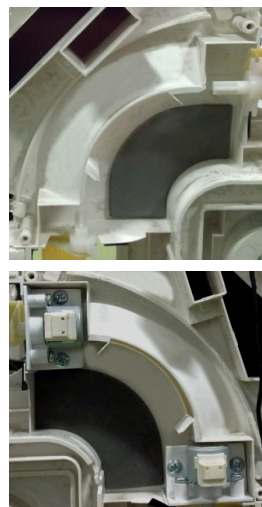
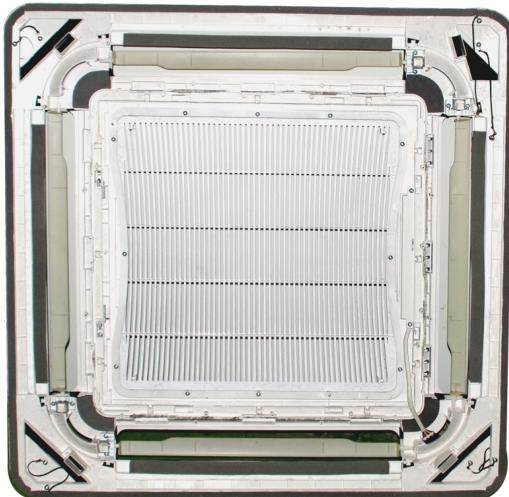

### 1.3 3D screw fan technology

- 3D screw indoor fan technology reduces the air resistance, increases the air volume and improves the heat exchange efficiency. Operate quietly.



### 1.4 Fresh air intake function

- Fresh air fulfills air quality more healthy and comfortable.

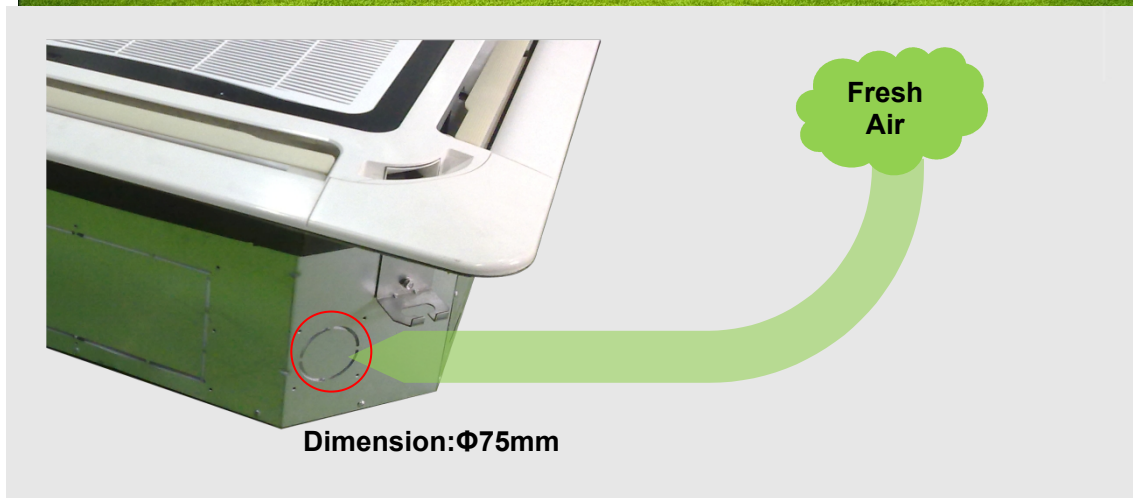

### 1.5 Air passage function

- Reserves the space for air outlet from the side of indoor unit; It's availed to connect air duct from side to nearby small rooms. For duct connecting

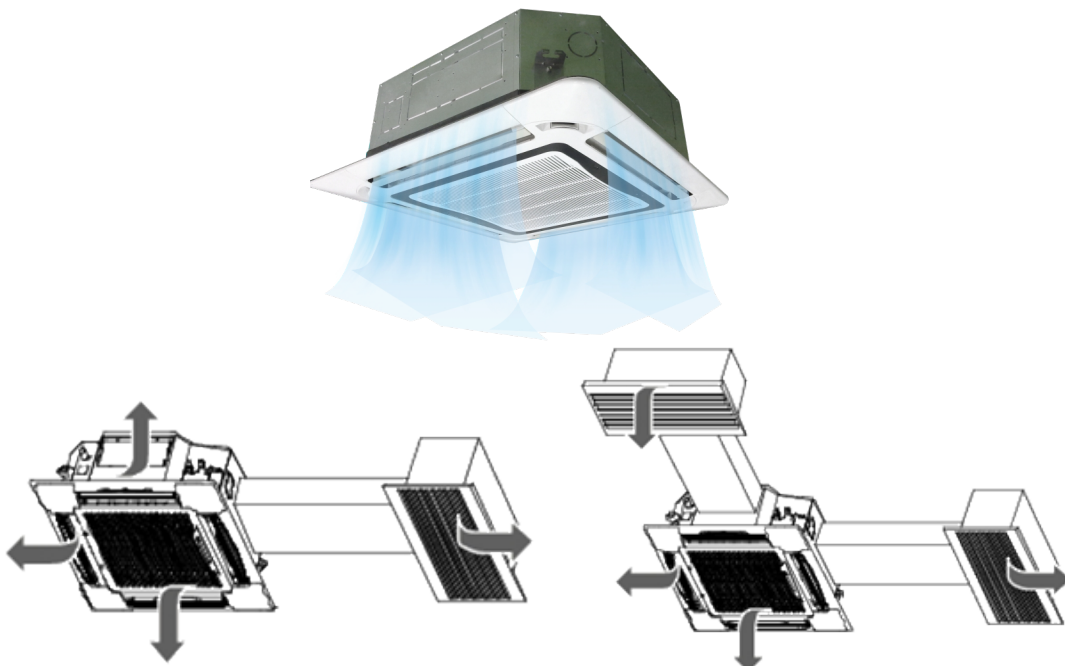



### 1.6 Drainage pump

- Build-in water pump which pumping head is 750mm upmost. It's convenient to install drainage piping under most space condition.

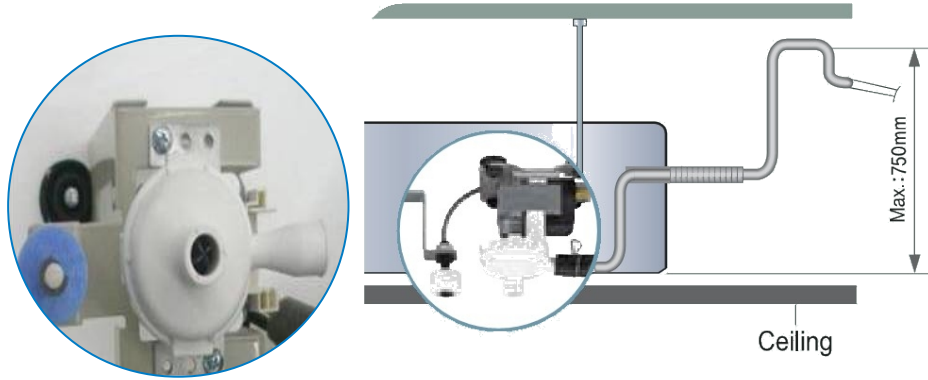

### 1.7 LED display

- Digital LED interface, makes the unit more elegant.
- Normally display the setting temperature
- LED can display the Error Code to make the malfunction checking easier.

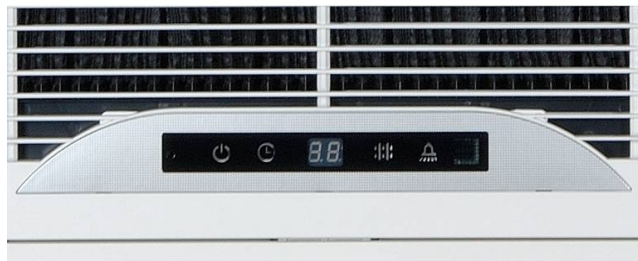

## 2. Dimensions

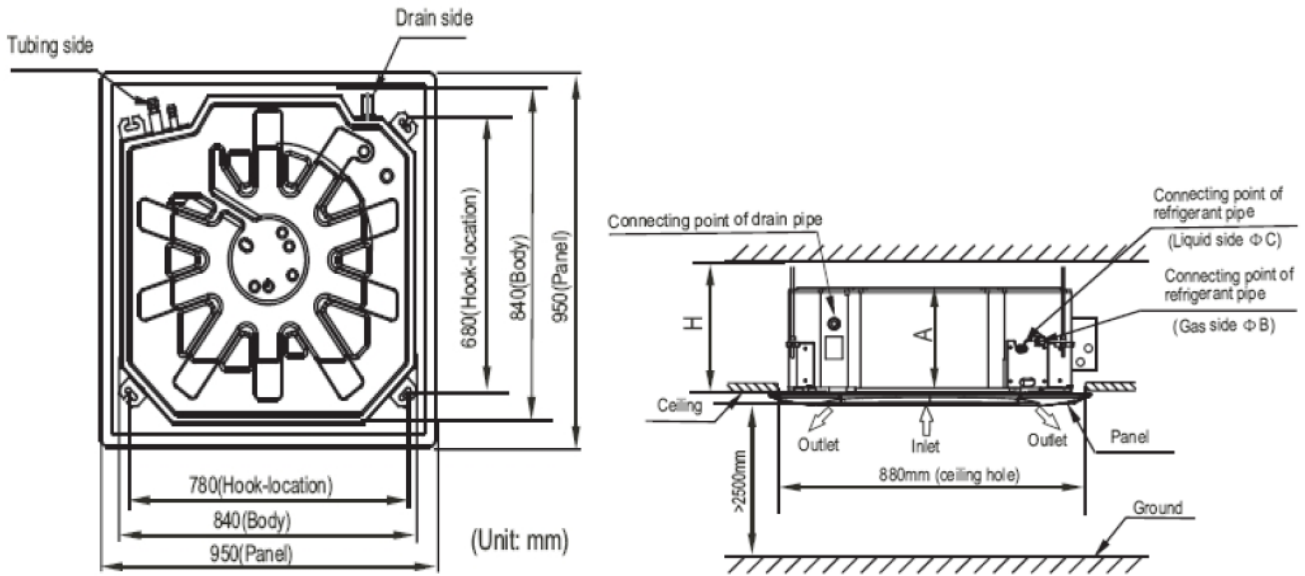

Unit: mm

MODEL(Btu/h)	A	B	C	H
24000	230	Φ15.9	Φ9.5	>260
30000	300	Φ15.9	Φ9.5	>330
36000	300	Φ15.9	Φ9.5	>330
48000	300	Φ15.9	Φ9.5	>330
60000	300	Φ15.9	Φ9.5	>330

## 3. Service Space

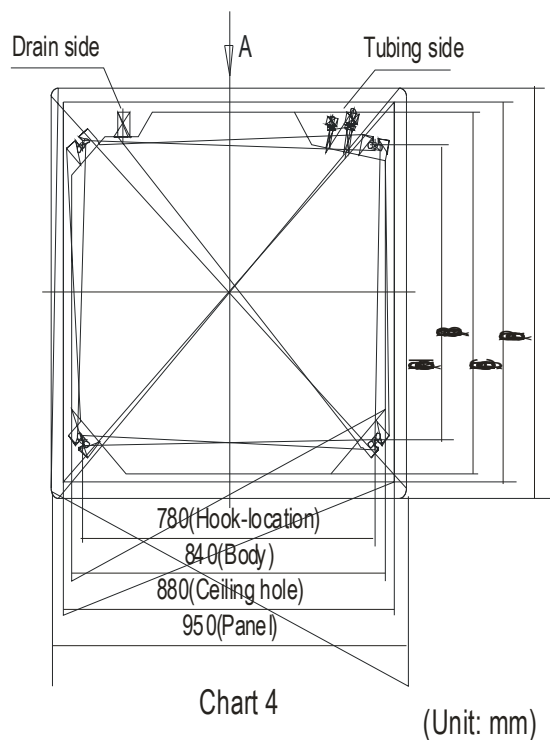
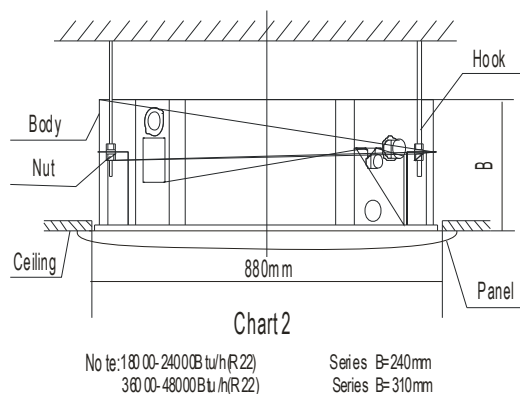
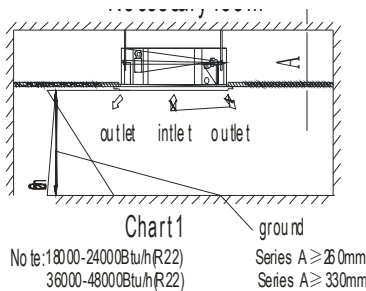

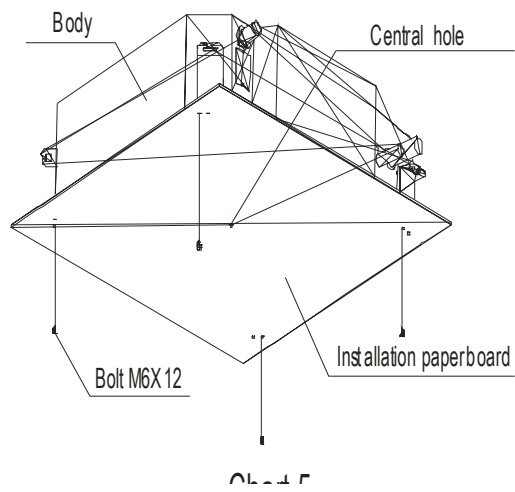
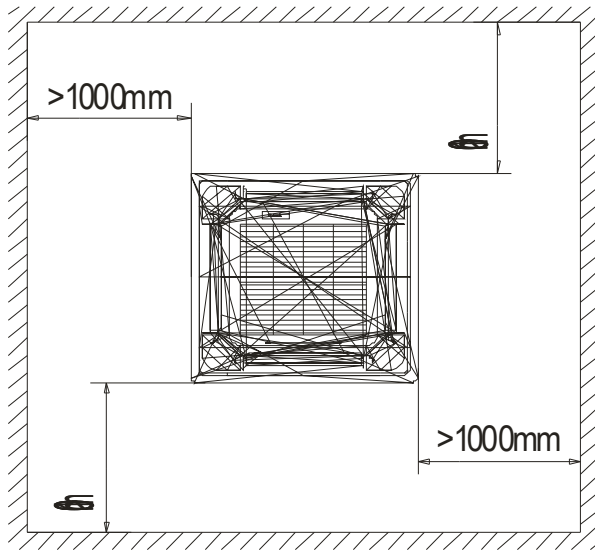



### 4. Wiring Diagrams MCC-24HRDN1-Q

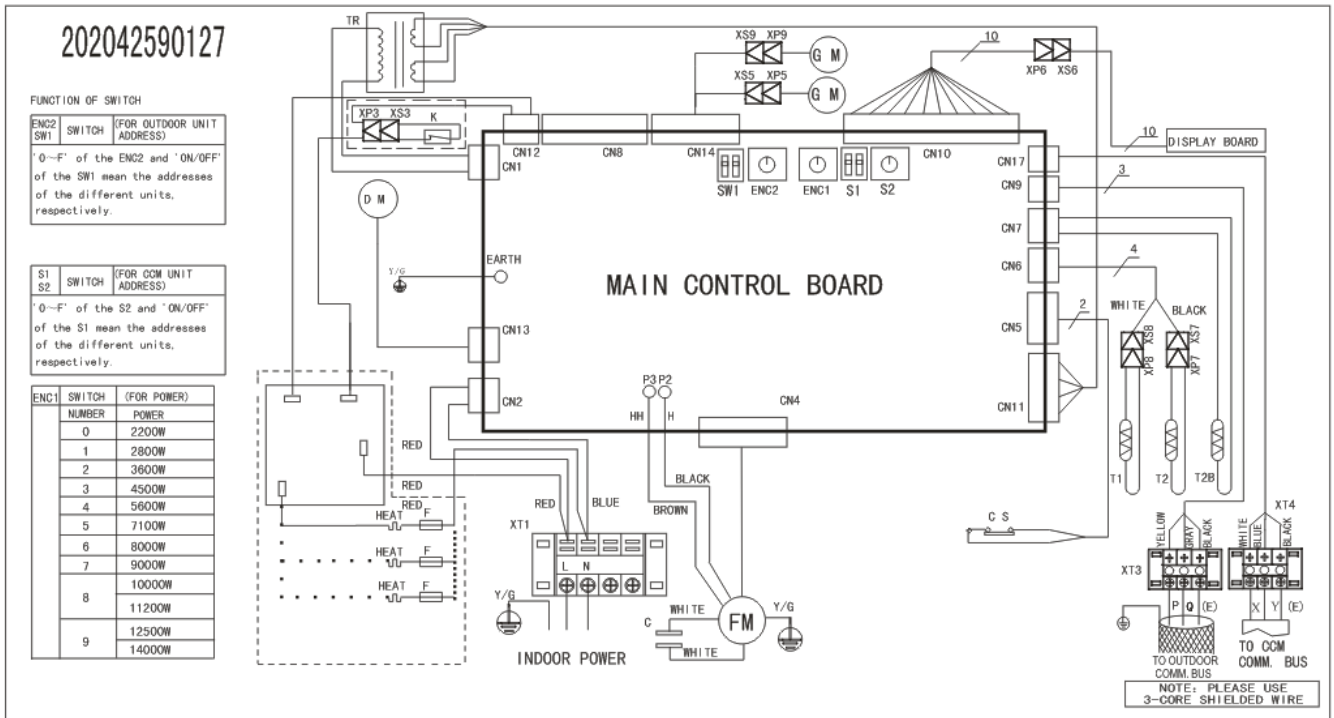

### MCC-30HRDN1-Q

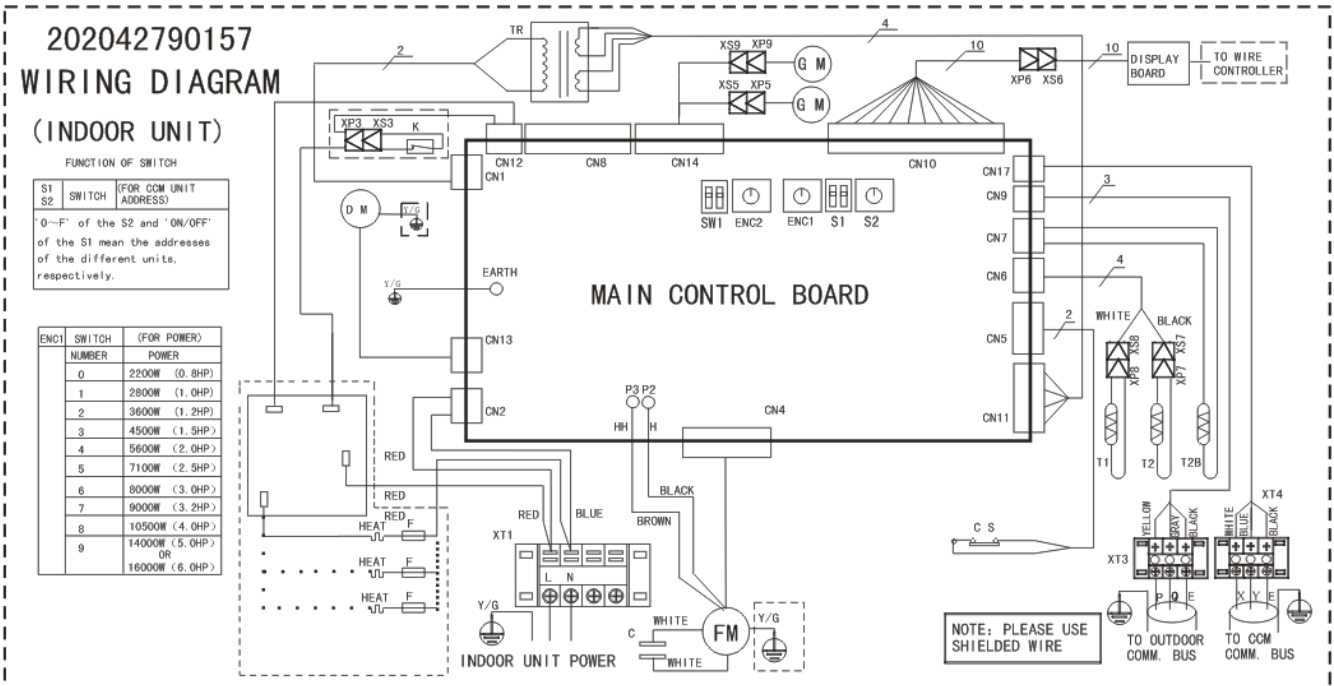

MCC-36HRDN1-Q MCC-48HRDN1-Q MCC-60HRDN1-R

WIRING DIAGRAMING  
202042890195

FUNCTION OF SWITCH

S1 SWITCH (FOR COM UNIT ADDRESS)  
"0-F" of the S2 and "ON/OFF" of the S1 mean the addresses of the different units, respectively.

S2	S1+S2	ADDRESS	S1+S2
0	32	0	32
1	47	1	47
2	15	2	15
3	31	3	31
4	48	4	48
5	63	5	63
6	16	6	16
7	31	7	31
8	48	8	48
9	63	9	63
A		A	

SW4 SWITCH	ON	OFF
Memory	NO	YES

ENC1 SWITCH	(FOR POWER)
NUMBER	POWER
4	5300W
5	7100W
6	8000W
7	9000W
8	10500W
9	14000W
A	16000W

SW1 SWITCH (SELECT TEMP.)	ON	OFF	ON	OFF
TE1	28	30	Fan motor do not stop.	According to E function
TE2	32	35		
TE3	30	32		
TE4	15	24		
Factory Setting	✓			

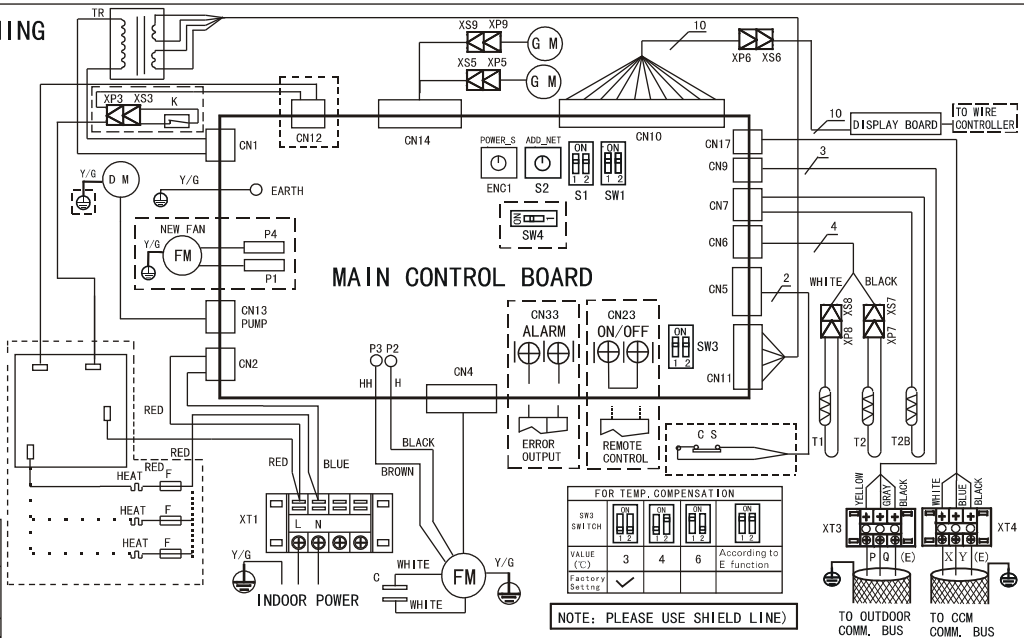

### 5. Air Velocity and Temperature Distributions

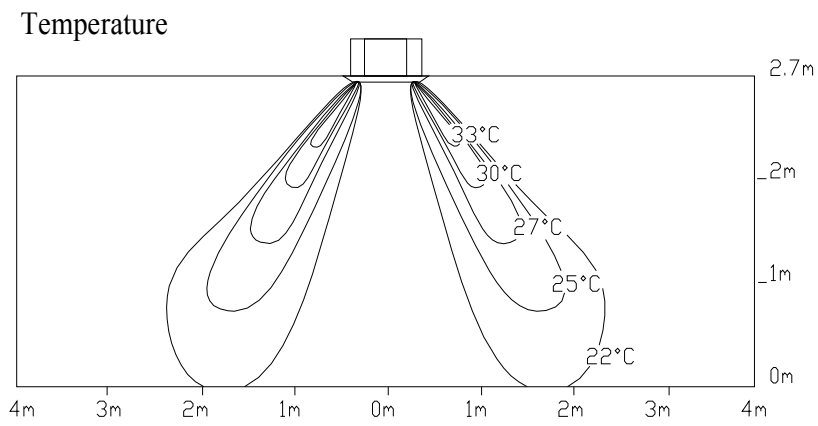
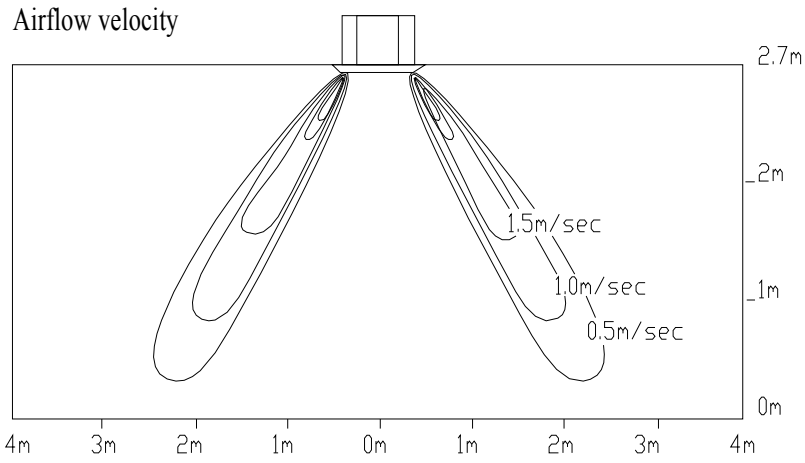

## 6. Electric Characteristics

Model	Indoor Unit				Power Supply
	Hz	Voltage	Min	Max	MFA
MCC-24HRDN1-Q	50	220-240	198	254	15
MCC-30HRDN1-Q	50	220-240	198	254	15
MCC-36HRDN1-Q	50	220-240	198	254	15
MCC-48HRDN1-Q	50	220-240	198	254	15
MCC-60HRDN1-R	50	220-240	198	254	15

Notes:





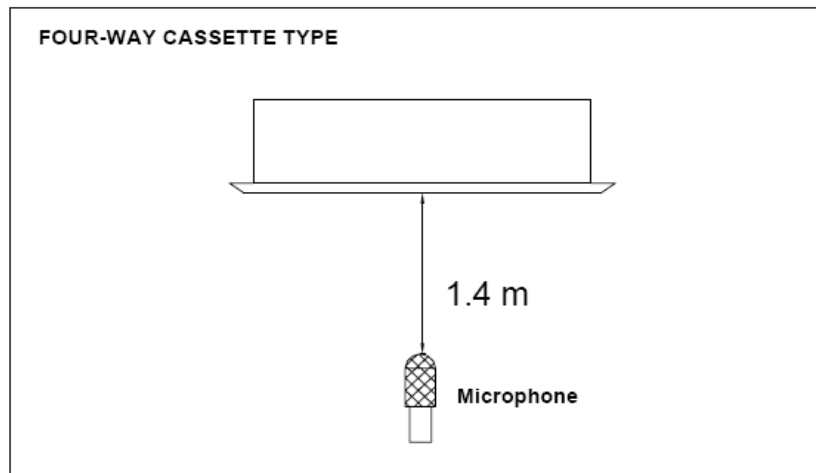



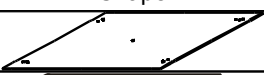

MFA: Max. Fuse Amps. (A)

## 7. Sound Levels



Model	Noise level dB(A)		
	H	M	L
MCC-24HRDN1-Q	42	41	39
MCC-30HRDN1-Q	44	42	41
MCC-36HRDN1-Q	44	42	41
MCC-48HRDN1-Q	44	42.5	41
MCC-60HRDN1-R	47	44	43

### 8. Accessories

	Name	Shape	Quantity
INSTALLATION FITTINGS	Installation paper board		1
	Tubing & Fittings	Soundproof / insulation sheath	
	Connecting pipe group		1
Drainpipe Fittings	Out-let pipe sheath		1
	Out-let pipe clasp		1
	Drain joint		1
	Seal ring		1
Remote controller & Its Frame	Remote controller & Its Frame		1
	Remote controller holder		1
	Mounting screw(ST2.9×10-C-H)		2
	Alkaline dry batteries (AM4)		2
Others	Owner's manual		1
	Installation manual		1

## 9. The Specification of Power

Model		18000-30000Btu/h	36000-60000 Btu/h	30000-60000 Btu/h
INDOOR UNIT POWER	Phase	1-phase	1-phase	1-phase
	Frequency and Voltage	220-240V, 50Hz	220-240V, 50Hz	220-240V, 50Hz
	POWER WIRING (mm <sup>2</sup> )	3×1.0	3×1.0	3×1.0
	CIRCUIT BREAKER (A)	15	15	15
OUTDOOR UNIT POWER	Phase	1-phase	1-phase	3-phase
	Frequency and Voltage	220-240V, 50Hz	220-240V, 50Hz	380-420V, 50Hz
	POWER WIRING (mm <sup>2</sup> )	3×2.5	3×4.0	5×2.5
	CIRCUIT BREAKER (A)	30	40	30
Indoor/Outdoor Connecting Wiring (Weak Electric Signal) (mm <sup>2</sup> )		3×0.5	3×0.5	3×0.5
Indoor/Outdoor Connecting Wiring (Strong Electric Signal) (mm <sup>2</sup> )		—————	—————	—————

# 10. Field Wiring

## Wiring chart

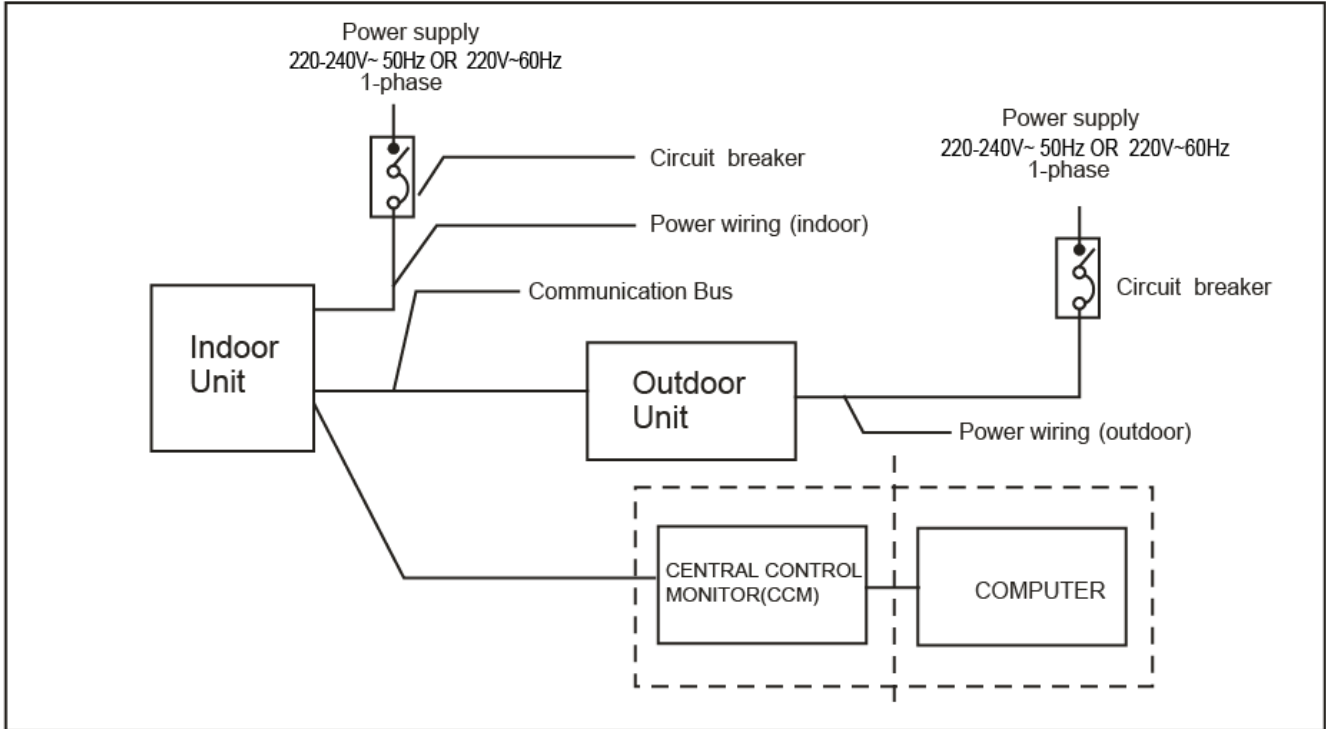

For model 18-48 (with 1-Phase outdoor unit)

### Air Condition Link-Circuit

202042890198

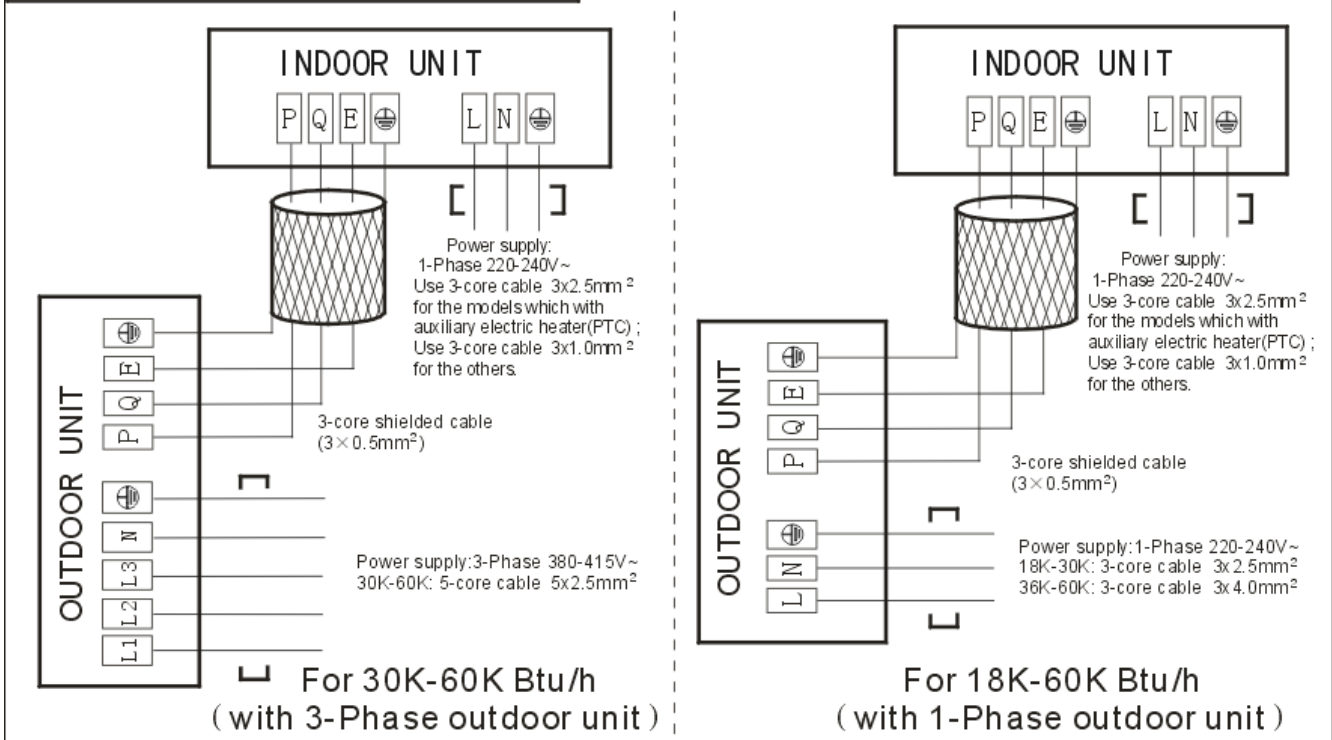

---

**Duct Type**

<b><u>1.Features.....</u></b>	<b><u>28</u></b>
<b><u>2.Dimensions.....</u></b>	<b><u>31</u></b>
<b><u>3.Service Space.....</u></b>	<b><u>32</u></b>
<b><u>4.Wiring Diagrams.....</u></b>	<b><u>33</u></b>
<b><u>5.Static Pressure.....</u></b>	<b><u>35</u></b>
<b><u>6.Electric Characteristics.....</u></b>	<b><u>36</u></b>
<b><u>7.Sound Levels.....</u></b>	<b><u>37</u></b>
<b><u>8.Accessories.....</u></b>	<b><u>38</u></b>
<b><u>9.The Specification of Power.....</u></b>	<b><u>39</u></b>
<b><u>10.Field Wiring.....</u></b>	<b><u>39</u></b>



# 1. Features

## 1.1 Installation accessories: (Optional)

- Front Board, Canvas Air Passage, Filter, Panel, for easy installation

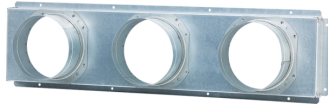

Front Board



Canvas Air Passage



Filter



Panel

## 1.2 Easy Installation: Two air inlet styles (Bottom side or Rear side)

- Air inlet from rear is standard for all capacity; air inlet from bottom is optional.
- The size of air inlet frame from rear and bottom is same, it's very easy to move the cover from bottom to rear side, or from rear to the bottom, in order to matching the installation condition.

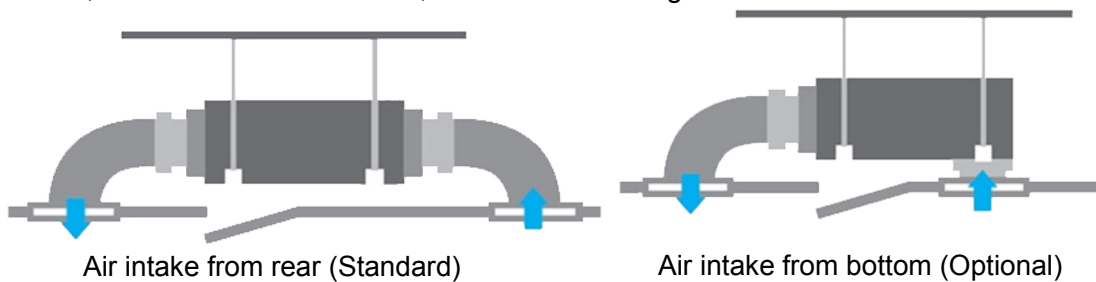

## 1.3 Fresh air intake function

- Install one duct from the reserved fresh-air intake to outdoor. Continually inhale the fresh air to improve the quality of the indoor air, fulfills air quality more healthy and comfortable.

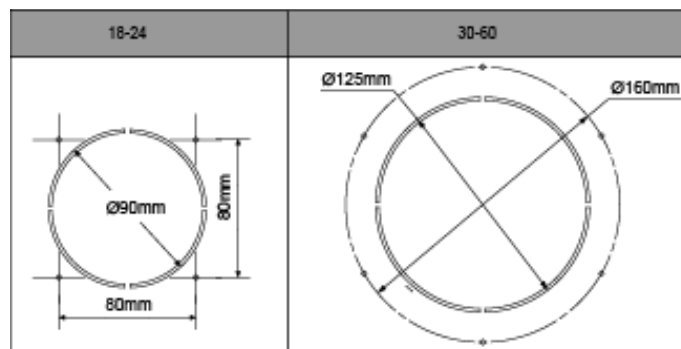

## 1.4 Easy maintenance

- Clean the filter (Optional, standard product without filter)  
It is easy to draw out the filter from the indoor unit for cleaning, even the filter is installed in rear side or bottom side.

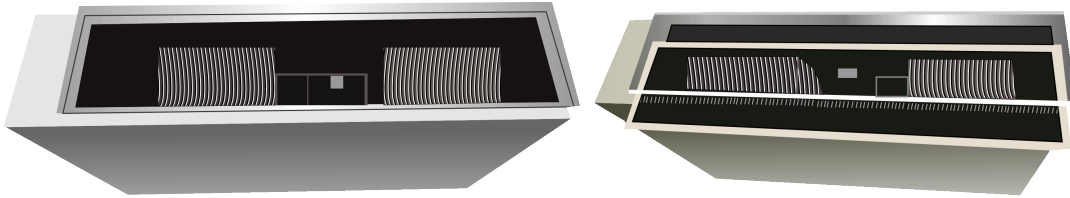

- Replace the motor or centrifugal fan  
Remove the ventilated panel firstly. Remove a half of blower housing and take out the motor with centrifugal fan. Directly remove two bolts, and then replace the motor or centrifugal fan easily.

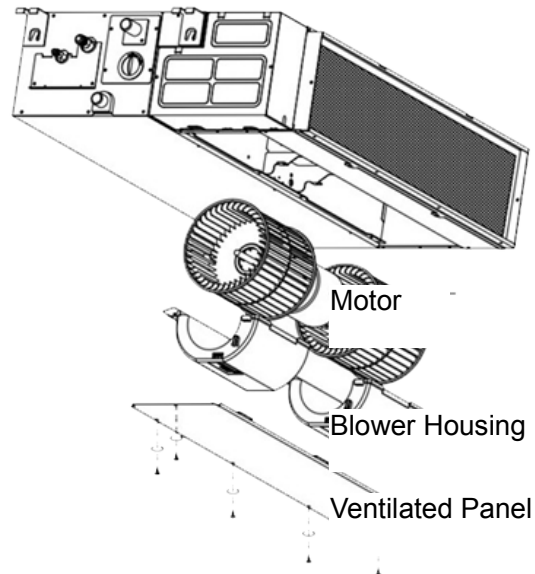

### 1.5 Reserved remote on-off and central control ports

- Reserved remote on-off ports and central control ports, can connect the cable of an on-off controller or a central controller to realize remote on-off control function or group control function.

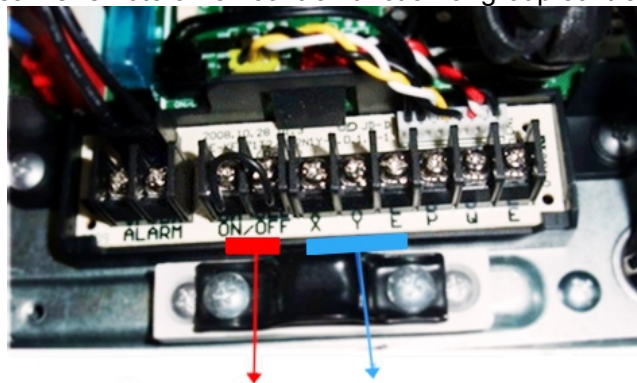

Remote on-off ports    Central control ports

### 1.6 Built-in drain pump (Optional):

- Built-in drain pump can lift the water to 750mm upmost. It's convenient to install drainage piping under most space condition.

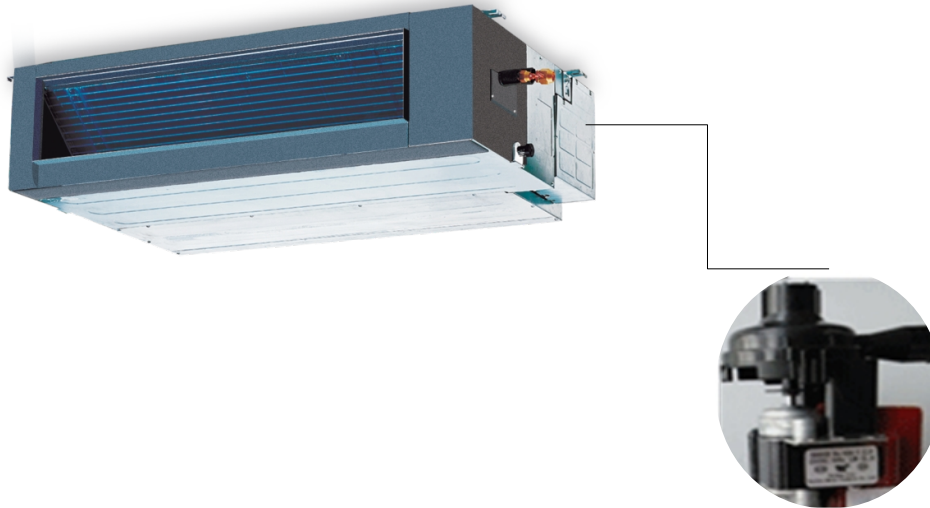
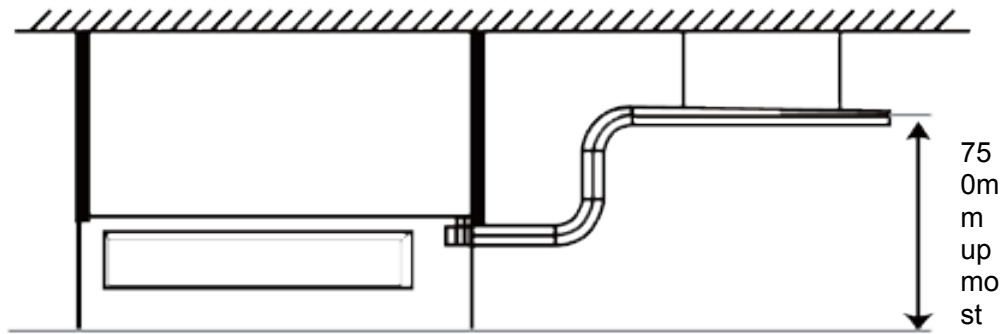

### 1.7 Built-in display board

- The standard indoor unit can be controlled by wired controller.
- There is a display board with a receiver in the E-box. Move out the display, and fix it in other place, even in the distance of 10m. The unit will realized remoter control.
- The wired controller and the display board can display the error code or production code when the chips detect some failure.

Wired Controller (Standard)

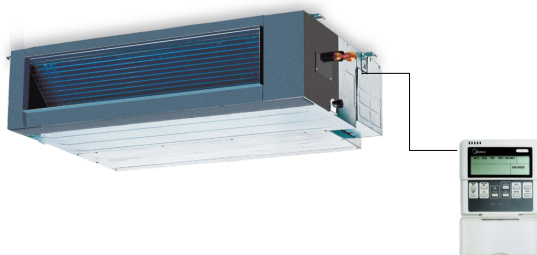

Remote Controller (Optional)

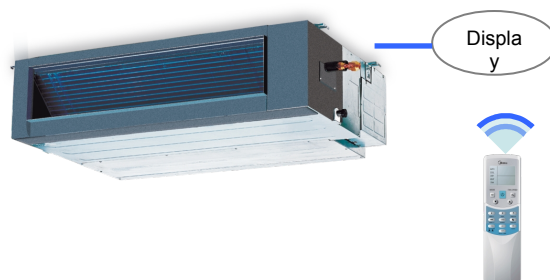

## 2. Dimensions

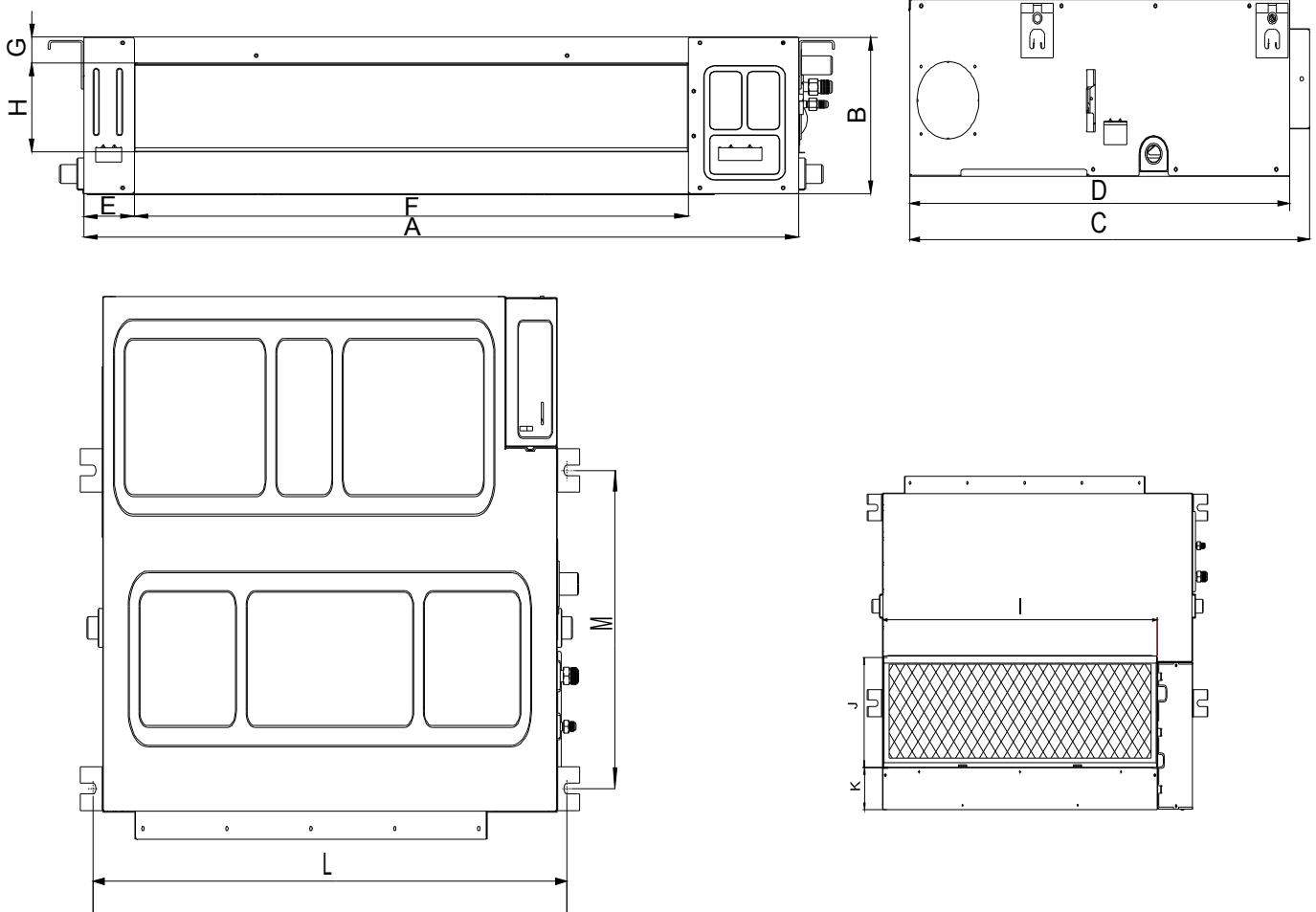

Capacity (KBtu)	Outline dimension(mm)				Air outlet opening size				Air return opening size			Size of outline dimension mounted plug	
	A	B	C	D	E	F	G	H	I	J	K	L	M
12	700	210	635	570	65	493	35	119	595	200	80	740	350
18	920	210	635	570	65	713	35	119	815	200	80	960	350
24	920	270	635	570	65	713	35	179	815	260	20	960	350
30/36	1140	270	775	710	65	933	35	179	1035	260	20	1180	490
48/60	1200	300	865	800	80	968	40	204	1094	288	45	1240	500

### 3. Service Space

Ensure enough space required for installation and maintenance.

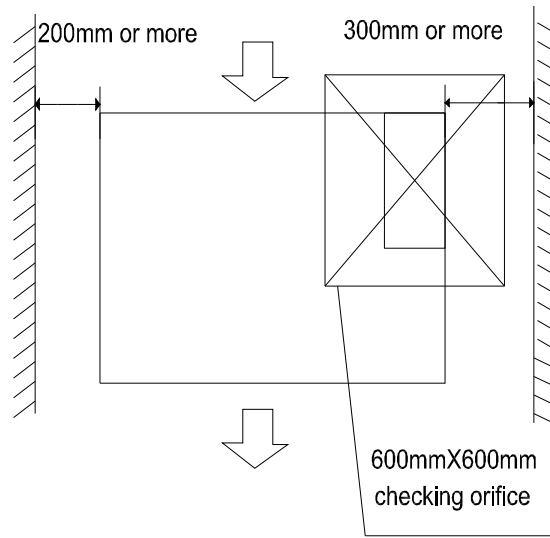

All the indoor units reserve the hole to joint the fresh air pipe. The hole size as following:

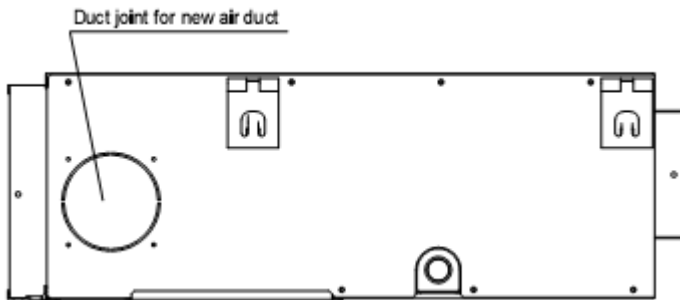

MODLE	
12-24	30-60

### 4. Wiring Diagrams

#### MTB1-12HWDN1-Q

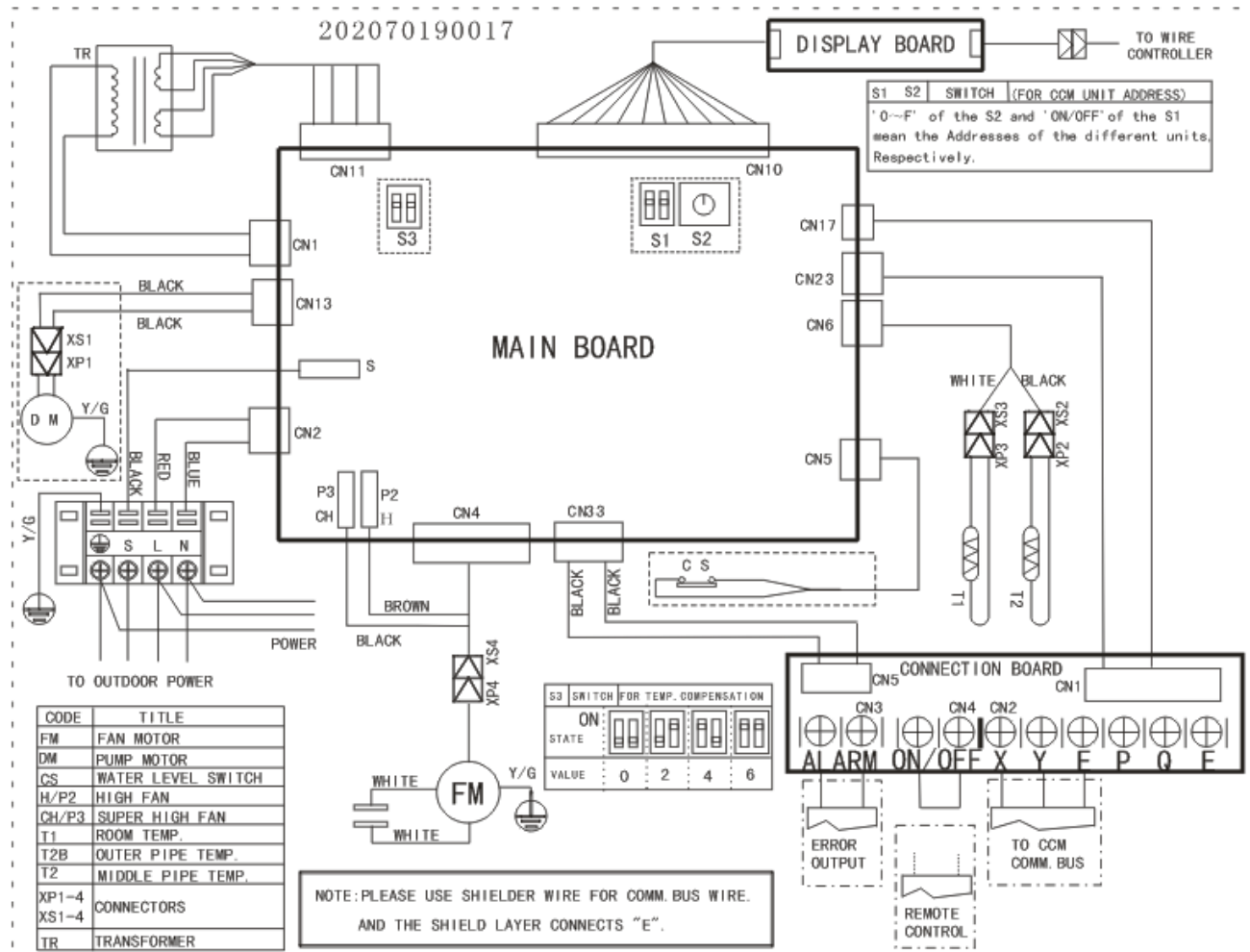

#### MTB-18HWDN1-Q, MTB-24HWDN1-Q, MTB-30HWDN1-Q

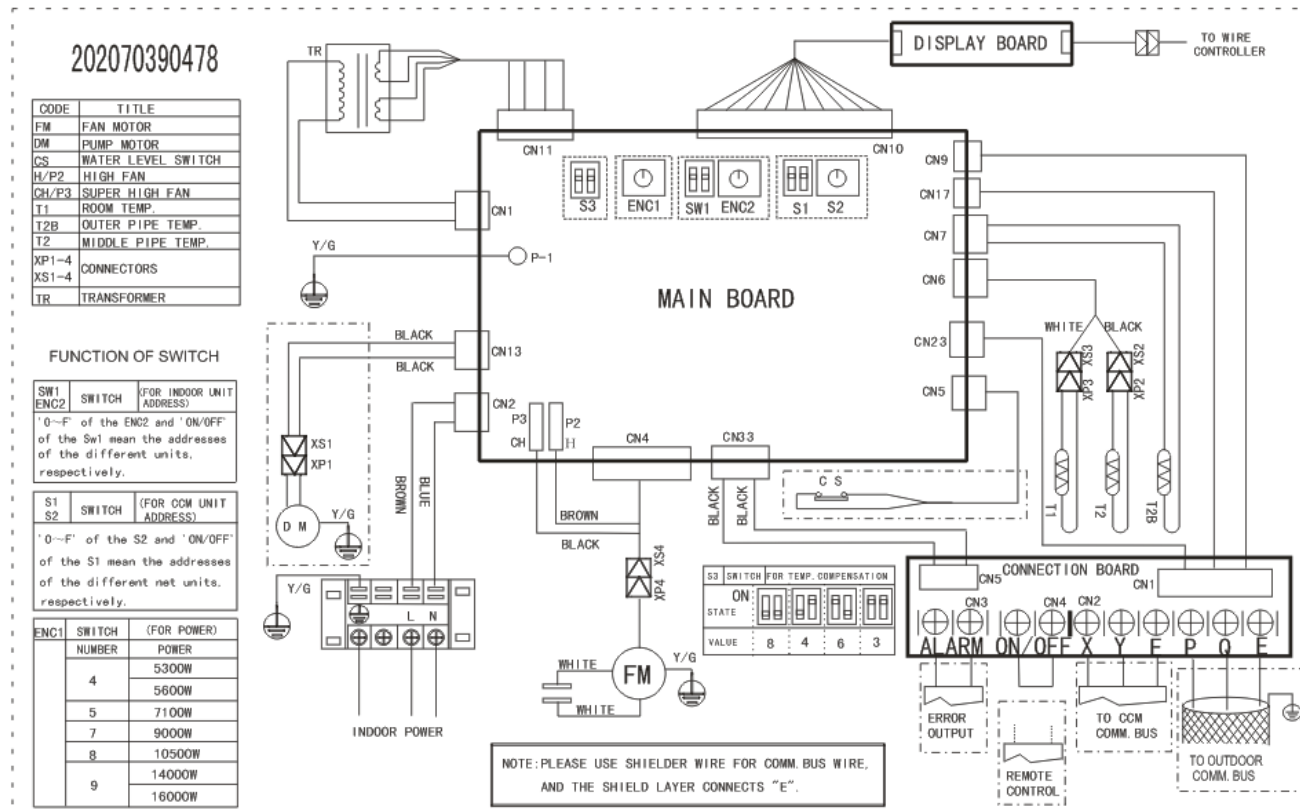

MTB-36HWDN1-Q MTB-48HWDN1-Q MTB-60HWDN1-R

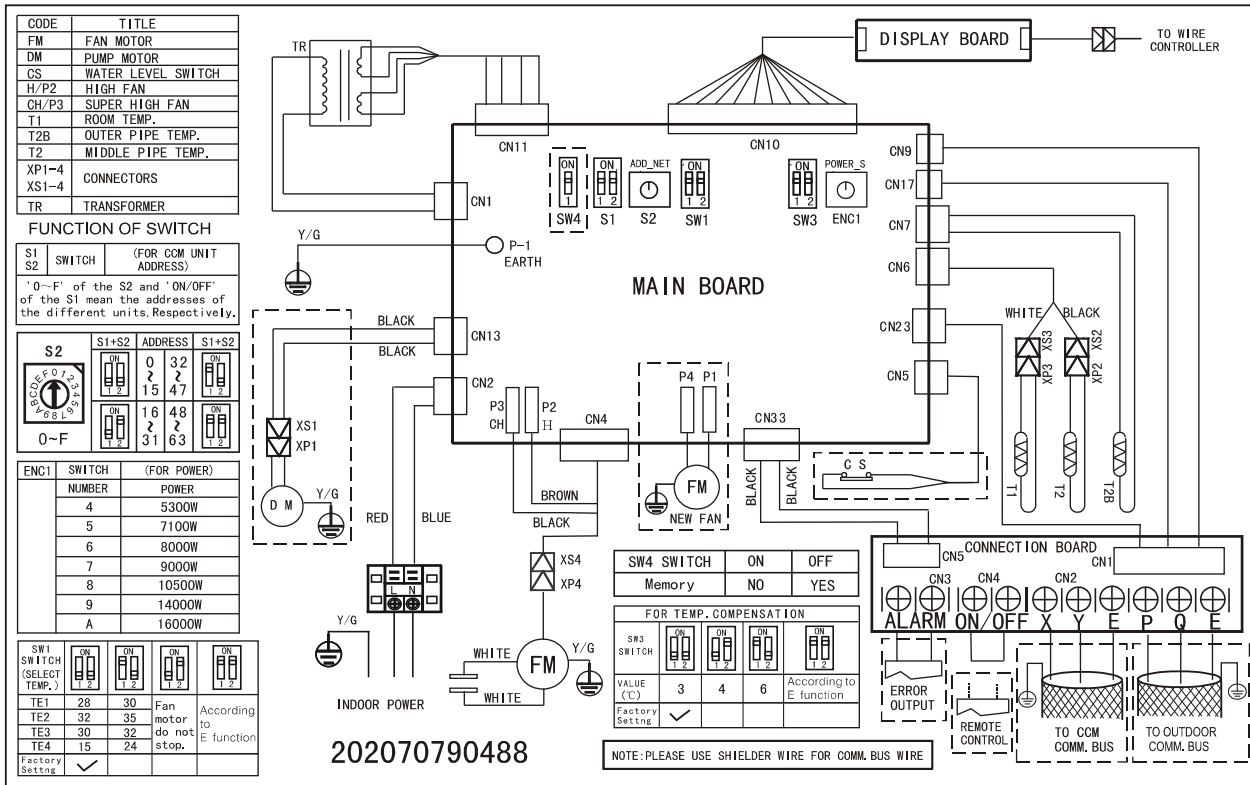

# 5. Static Pressure

12,000Btu/h

18,000Btu/h

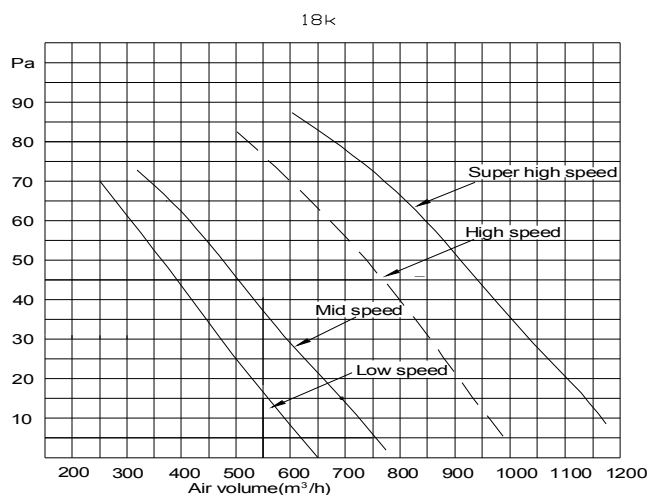
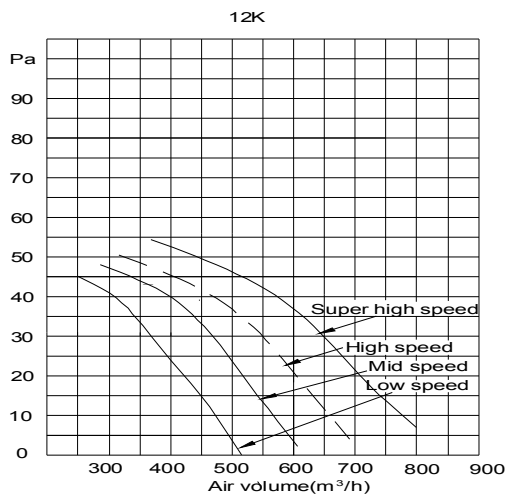

24,000Btu/h

36,000Btu/h

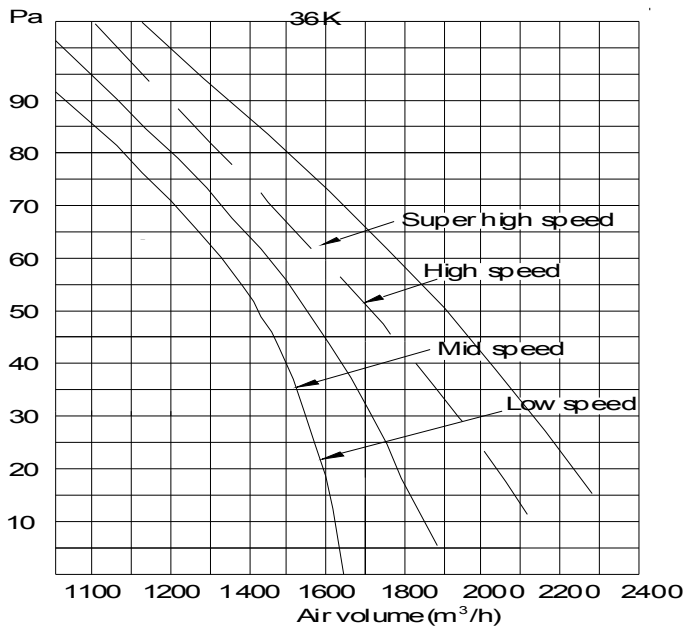
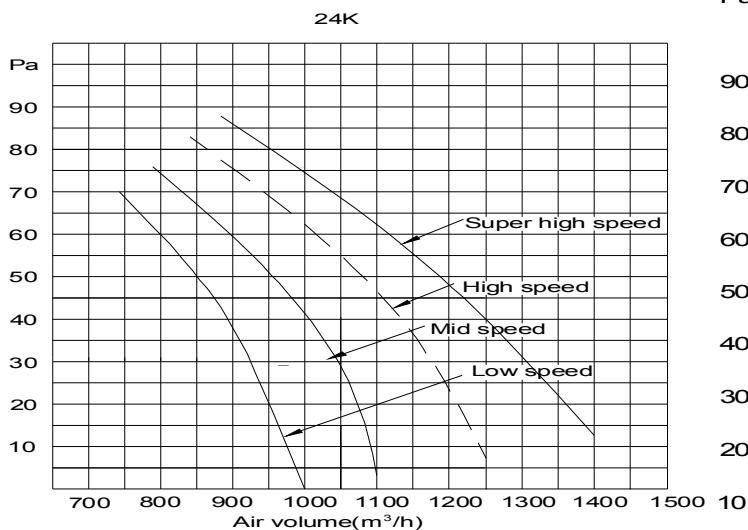



**48,000Btu/h**

**60,000Btu/h**

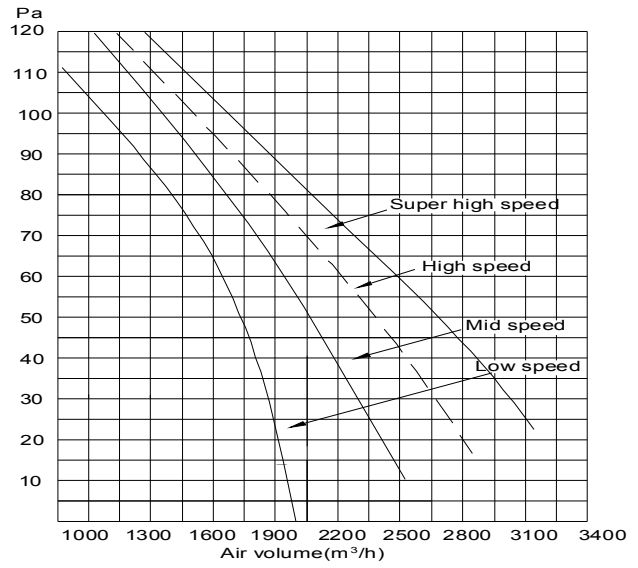
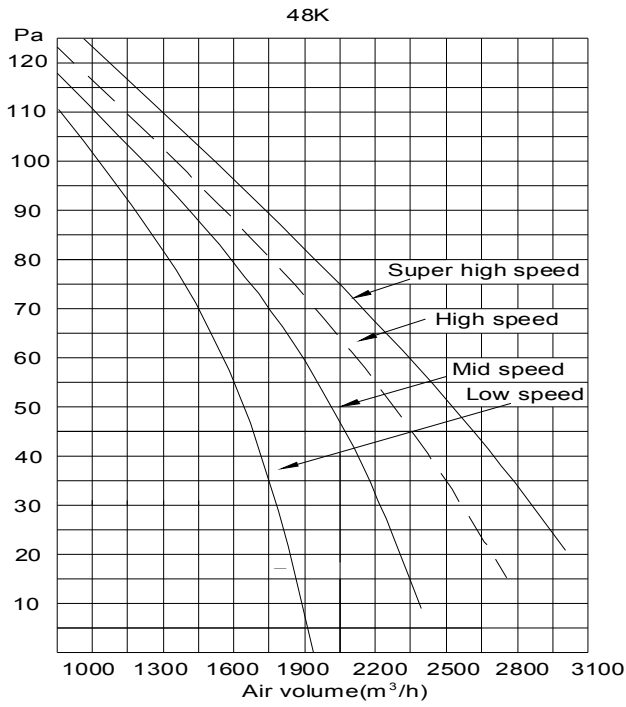

**6. Electric Characteristics**

Model	Indoor Unit				Power Supply
	Hz	Voltage	Min.	Max.	MFA
MTB1-12HWDN1-Q	50	220-240	198	254	15
MTB-18HWDN1-Q	50	220-240	198	254	15
MTB-24HWDN1-Q	50	220-240	198	254	15
MTB-30HWDN1-Q	50	220-240	198	254	15
MTB-36HWDN1-Q	50	220-240	198	254	15
MTB-48HWDN1-Q	50	220-240	198	254	15
MTB-60HWDN1-R	50	220-240	198	254	15

**Notes:**





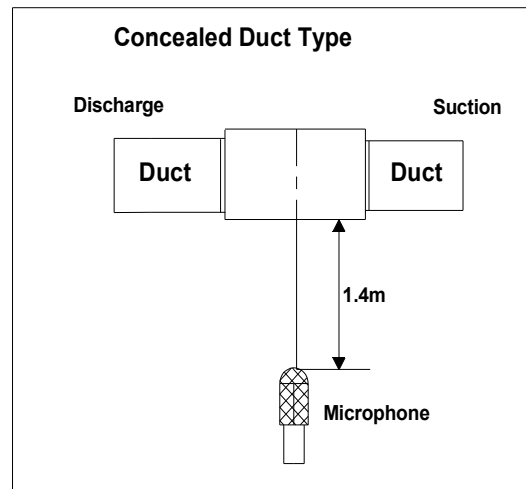



MFA: Max. Fuse Amps. (A)

## 7. Sound Levels



Model	Noise level dB(A)		
	H	M	L
MTB1-12HWDN1-Q	37	30	26
MTB-18HWDN1-Q	44	36	33
MTB-24HWDN1-Q	45	43	41
MTB-30HWDN1-Q	46	44	42
MTB-36HWDN1-Q	46	44	42
MTB-48HWDN1-Q	47	41	37
MTB-60HWDN1-R	47	45	43

## 8. Accessories

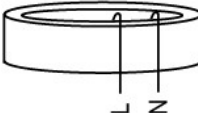
	Name	Shape	Quantity
<b>Tubing &amp; Fittings</b>	Soundproof / insulation sheath		2
	Binding tape		1
	Seal sponge		1
<b>Drainpipe Fittings (for cooling &amp; heating)</b>	Drain joint		1
	Seal ring		1
<b>Wired controller &amp; Its Frame</b>	Wired controller		1
<b>Others</b>	Owner's manual		1
	Installation manual		1
<b>EMS &amp; It's fitting</b>	Magnetic ring (twist the electric wires L and N around it to five circles)		1

### 9. The Specification of Power

Model		12000Btu/h	18000-30000Btu/h	36000-60000 Btu/h	30000-60000 Btu/h
INDOOR UNIT POWER	Phase	1-phase	1-phase	1-phase	1-phase
	Frequency and Voltage	220-240V, 50Hz	220-240V, 50Hz	220-240V, 50Hz	220-240V, 50Hz
	POWER WIRING (mm <sup>2</sup> )	3×1.5	3×1.0	3×1.0	3×1.0
	CIRCUIT BREAKER (A)	15	15	15	15
OUTDOOR UNIT POWER	Phase	—————	1-phase	1-phase	3-phase
	Frequency and Voltage	—————	220-240V, 50Hz	220-240V, 50Hz	380-420V, 50Hz
	POWER WIRING (mm <sup>2</sup> )	—————	3×2.5	3×4.0	5×2.5
	CIRCUIT BREAKER (A)	—————	30	40	40
Indoor/Outdoor Connecting Wiring (Weak Electric Signal) (mm <sup>2</sup> )		4×1.5	3×0.5	3×0.5	3×0.5
Indoor/Outdoor Connecting Wiring (Strong Electric Signal) (mm <sup>2</sup> )		—————	—————	—————	—————

### 10. Field Wiring

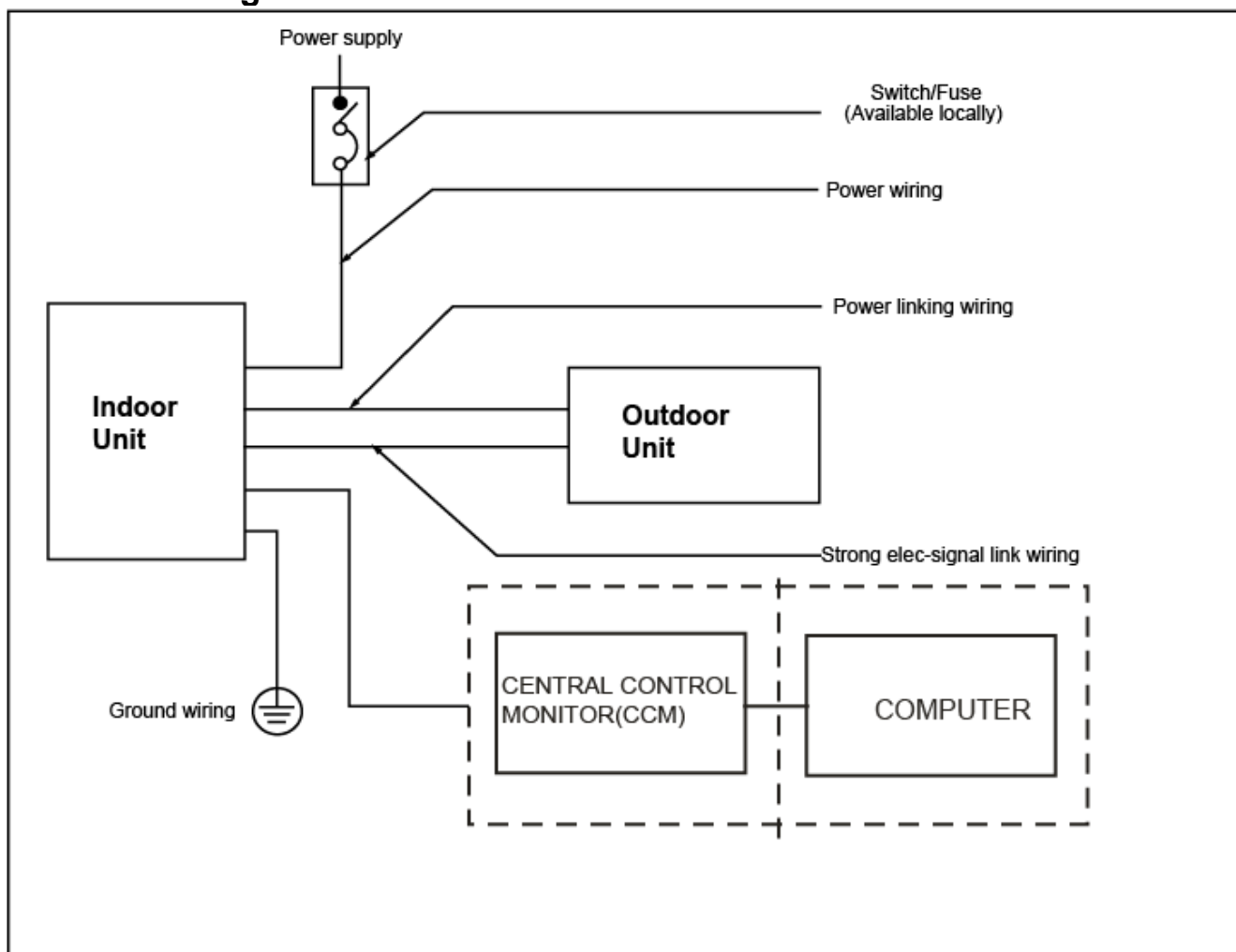

For Model12 (with 1-Phase outdoor unit)

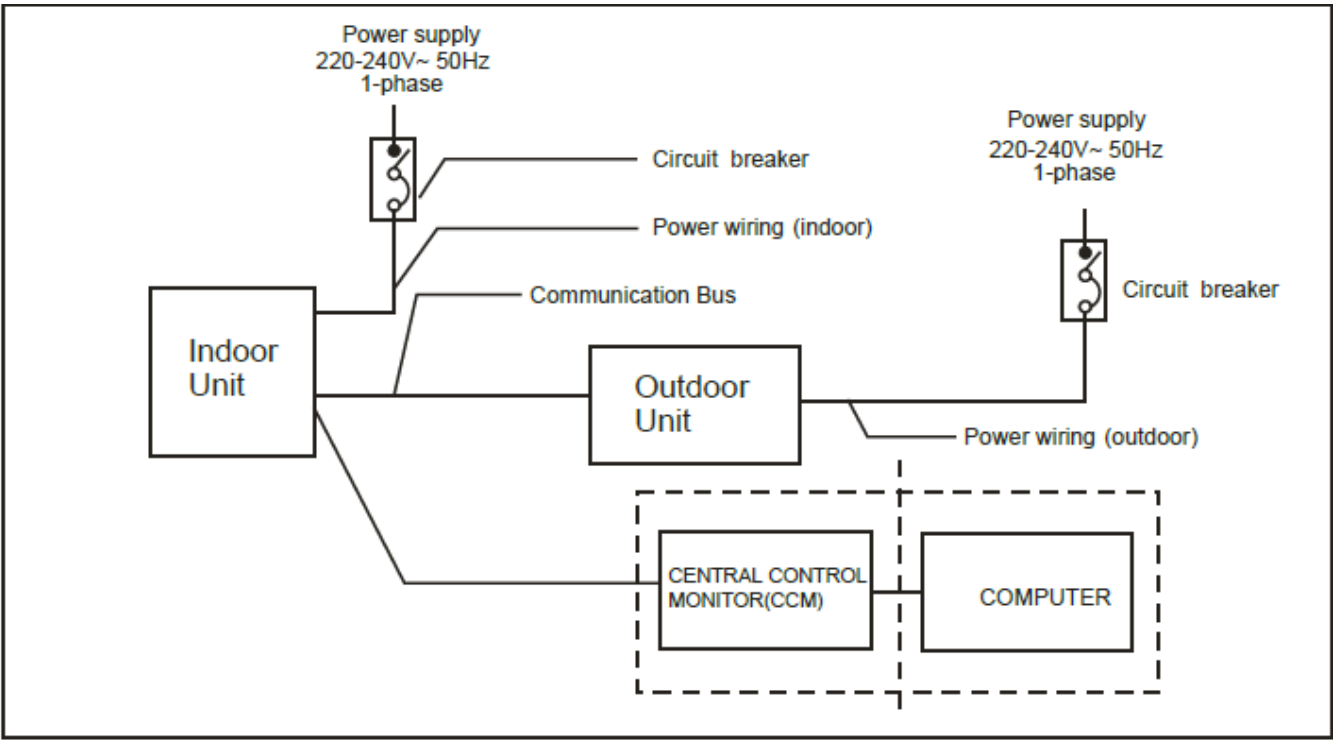

For Model 18-60(with 1-Phase outdoor unit)

Air-conditioner link-circuit.  
For model 12

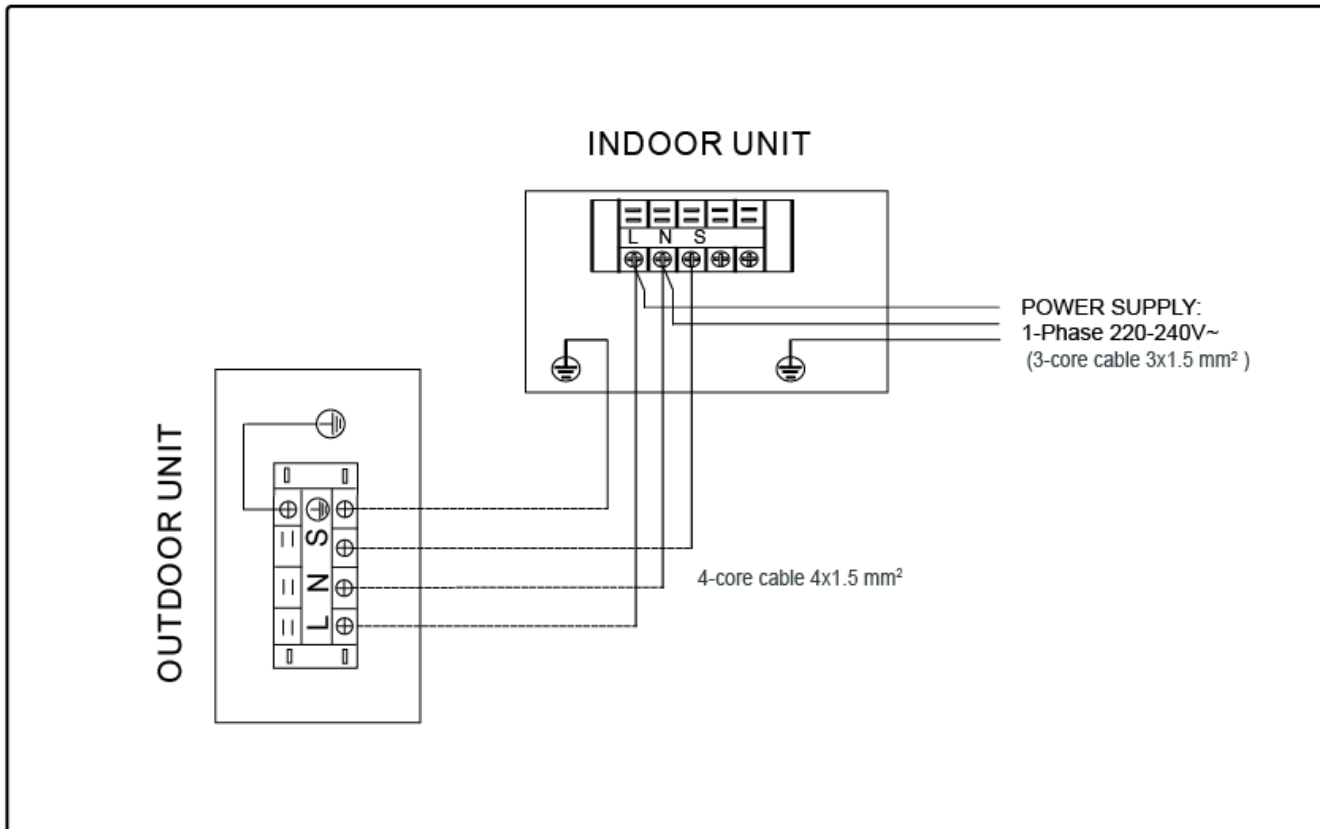

For model 18-60

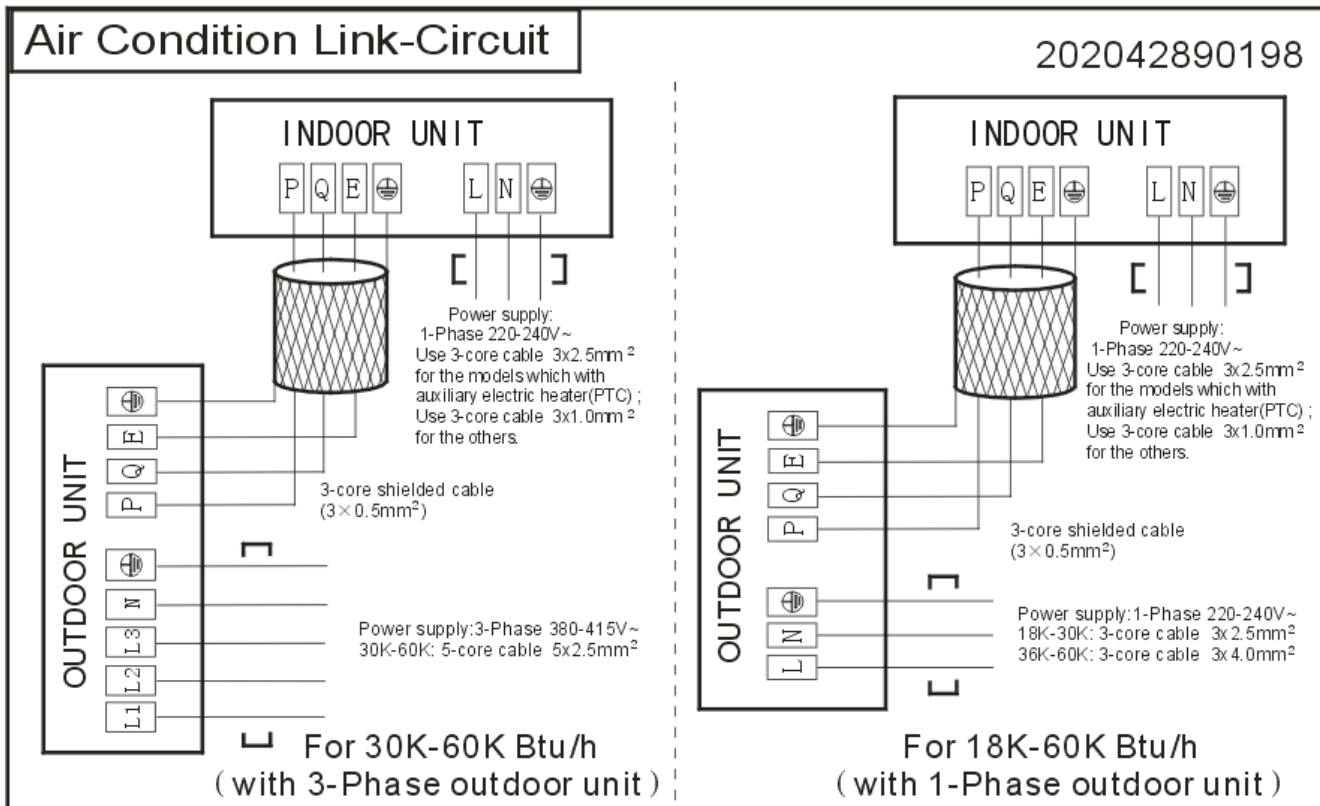

## **Part 3**

### **Outdoor Units**

<a href="#"><u>1.Dimensions.....</u></a>	<a href="#"><u>43</u></a>
<a href="#"><u>2.Service Space .....</u></a>	<a href="#"><u>45</u></a>
<a href="#"><u>3.Piping Diagrams.....</u></a>	<a href="#"><u>46</u></a>
<a href="#"><u>4.Wiring Diagrams.....</u></a>	<a href="#"><u>48</u></a>
<a href="#"><u>5.Electric Characteristics.....</u></a>	<a href="#"><u>54</u></a>
<a href="#"><u>6.Operation Limits.....</u></a>	<a href="#"><u>55</u></a>
<a href="#"><u>7.Sound Levels.....</u></a>	<a href="#"><u>57</u></a>
<a href="#"><u>8.Point Check Function.....</u></a>	<a href="#"><u>58</u></a>
<a href="#"><u>9.Troubleshooting.....</u></a>	<a href="#"><u>59</u></a>

# 1. Dimensions

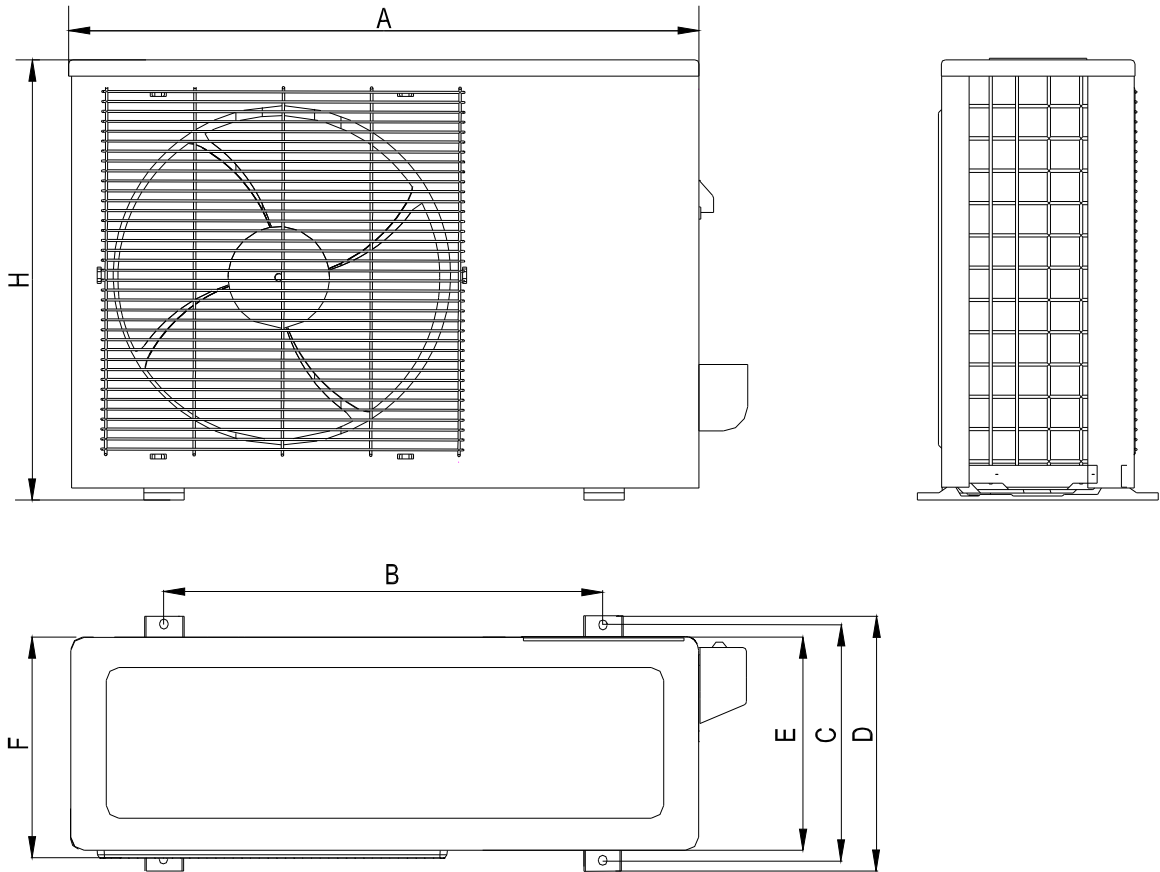

Model	Unit: mm						
	A	B	C	D	E	F	H
MOU-12HDN1-Q	761	530	290	315	270	279	593
MOU-18HDN1-Q	762	530	290	315	270	282	593
MOU-24HDN1-Q	842	560	335	360	312	324	695
MOU-36HDN1-Q	990	624	366	396	340	354	966
MOU-36HDN1-R							



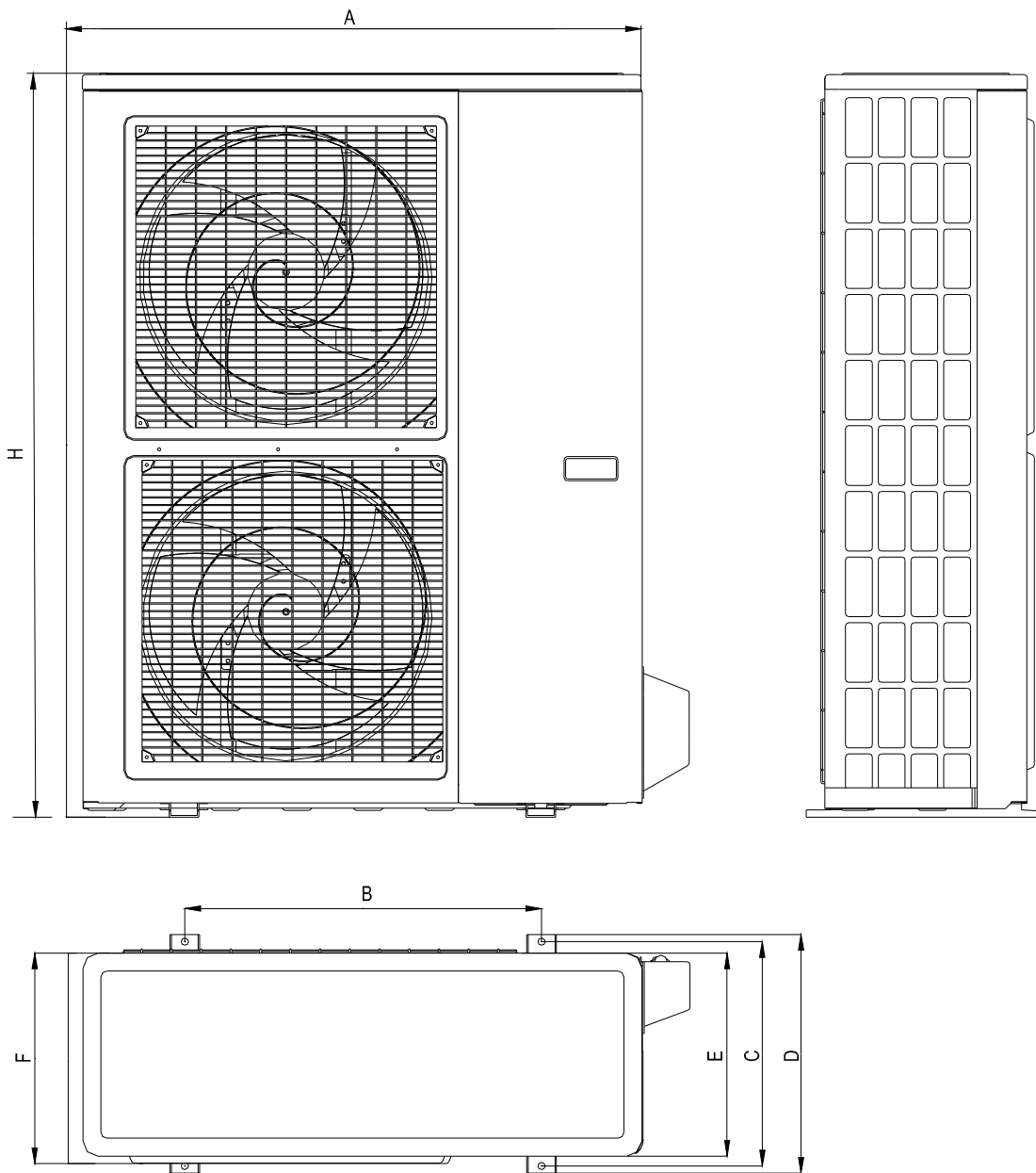

Model	Unit: mm						
	A	B	C	D	E	F	H
MOU-48HDN1-Q	940	600	376	400	340	360	1245
MOU-48HDN1-R							
MOU-60HDN1-R							

## 2. Service Space

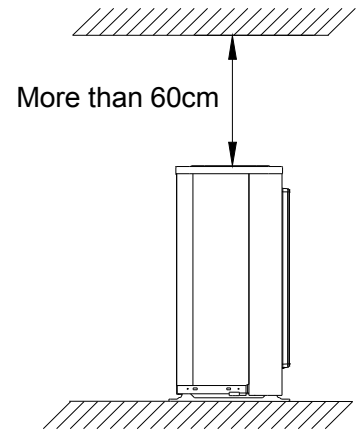
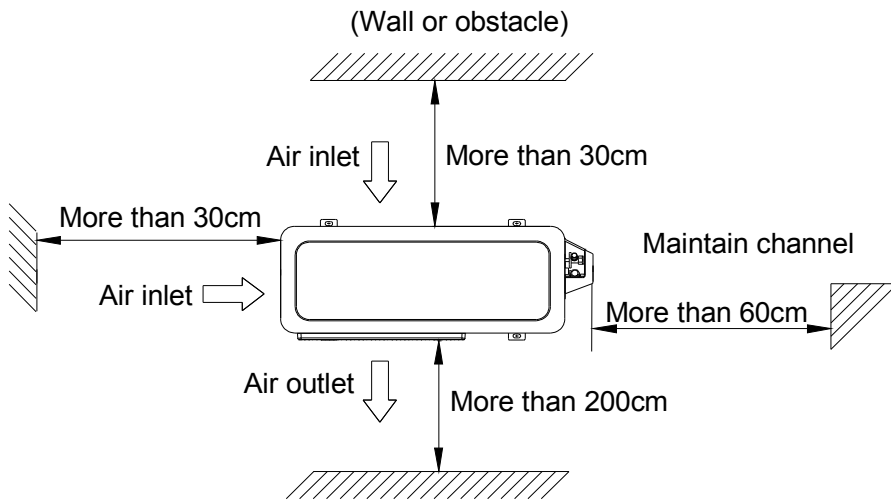

### 3. Piping Diagrams

MOU-12HDN1-Q MOU-24HDN1-Q(220075301401)

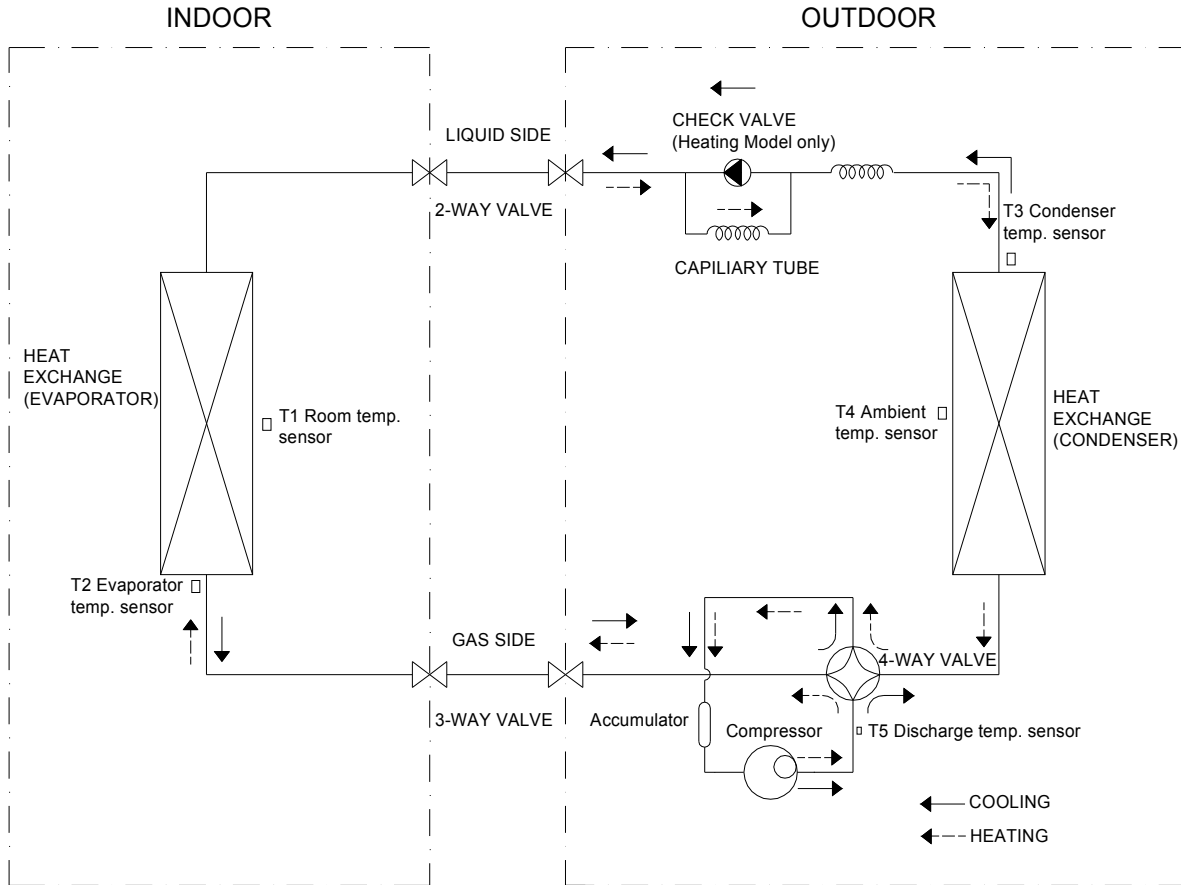

For MOU-24HDN1-Q, the accumulator is not included.

MOU-18HDN1-Q MOU-24HDN1-Q(220075301400) MOU-30HDN1-Q

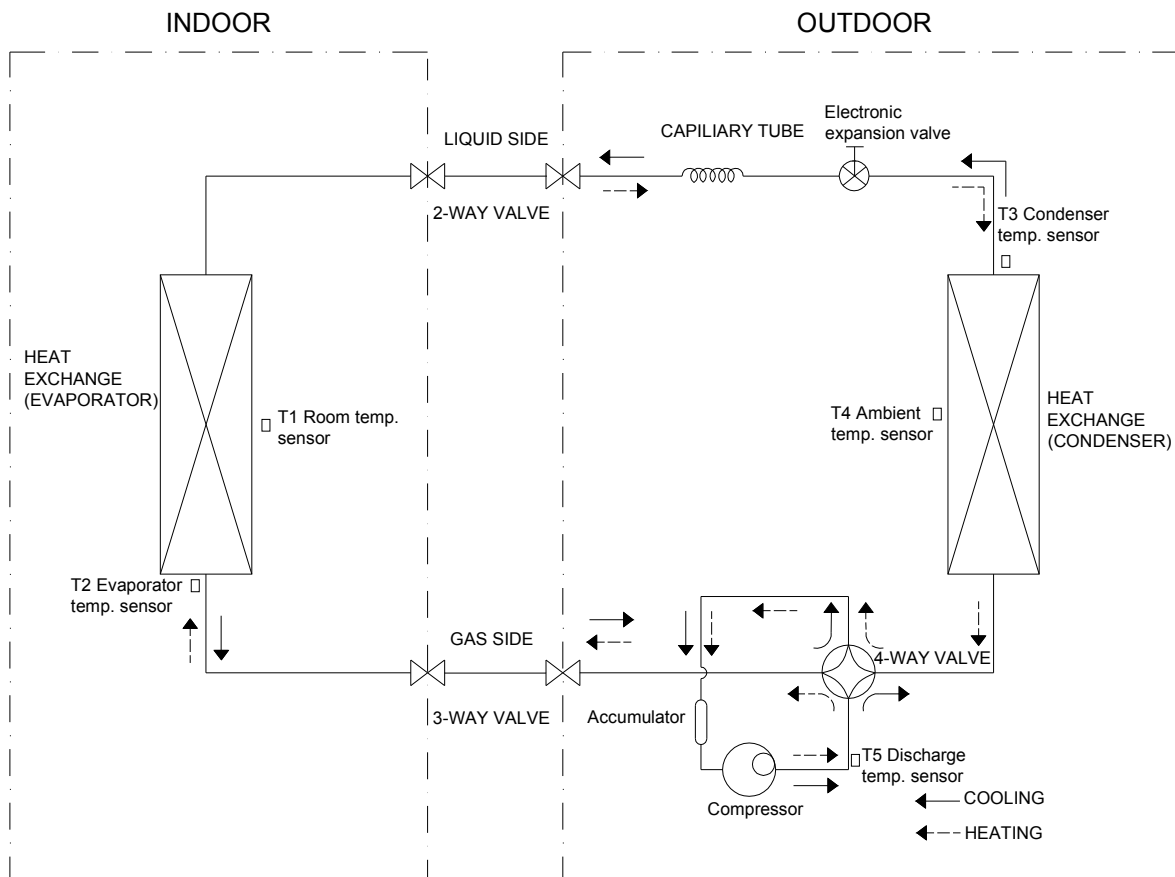

For MOU-24HDN1-Q, the accumulator is not included.

**MOU-36HDN1-Q MOU-36HDN1-R MOU-48HDN1-Q MOU-48HDN1-R MOU-60HDN1-R**

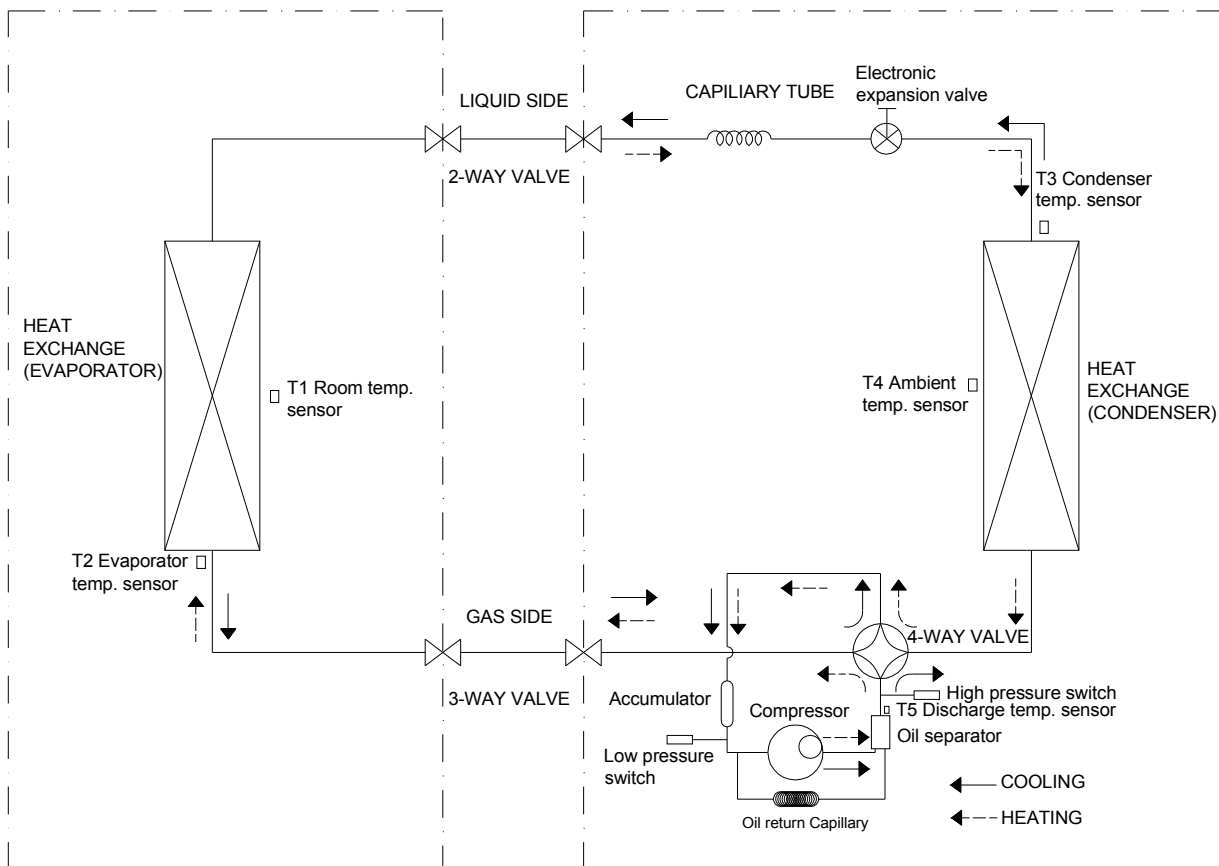

For MOU-48HDN1-Q, MOU-48HDN1-R and MOU-60HDN1-R, the accumulator is not included.

## 4. Wiring Diagrams

MOU-12HDN1-Q

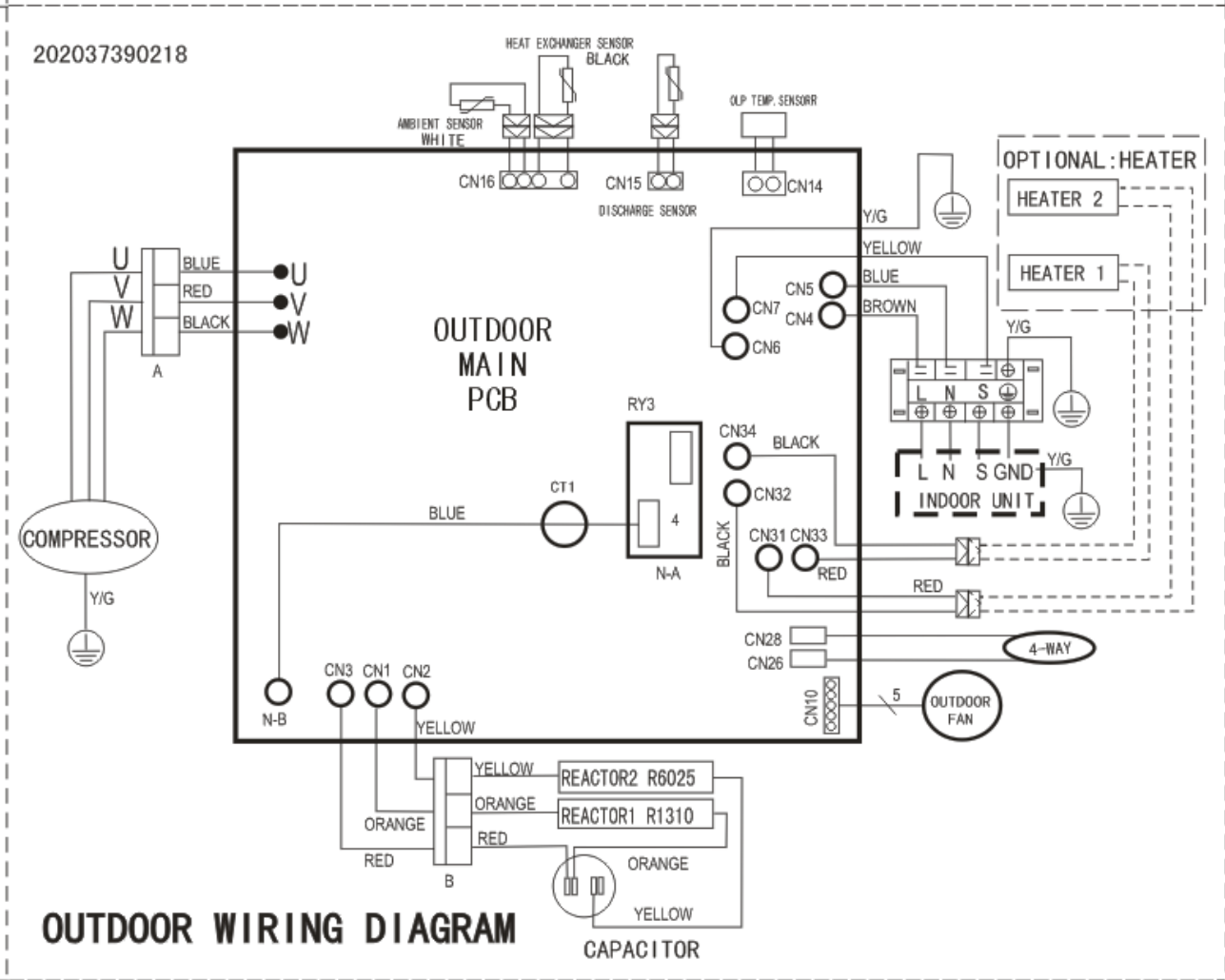

MOU-18HDN1-Q

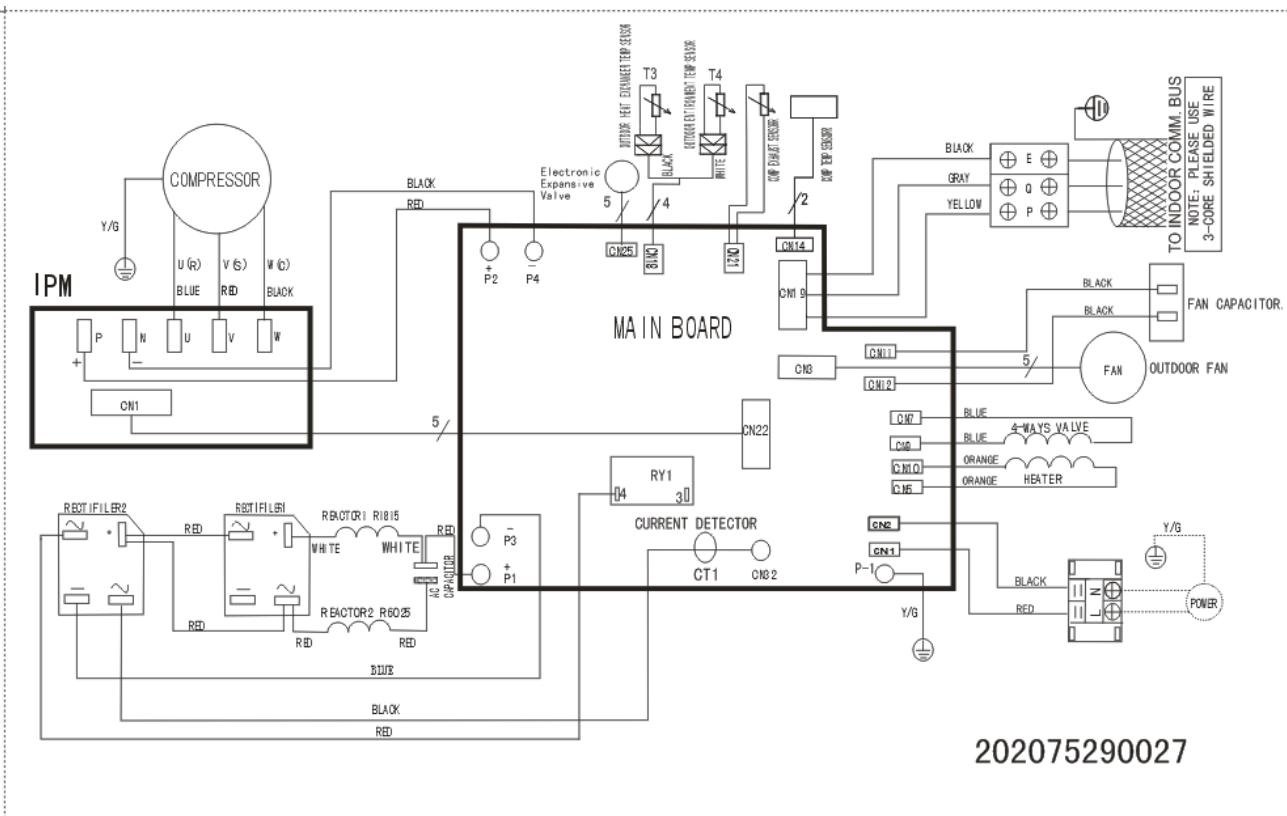

MOU-24HDN1-Q(220075301400)

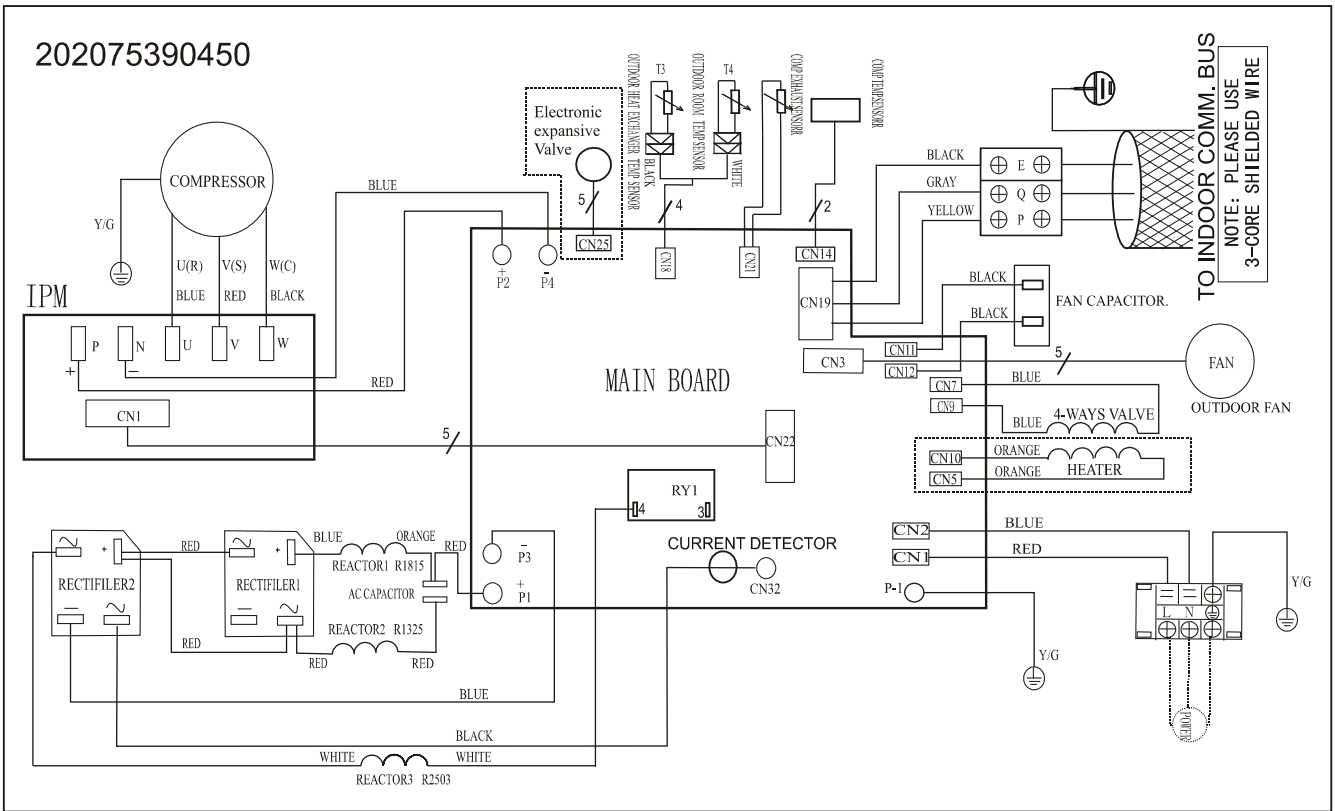

MOU-30HDN1-Q

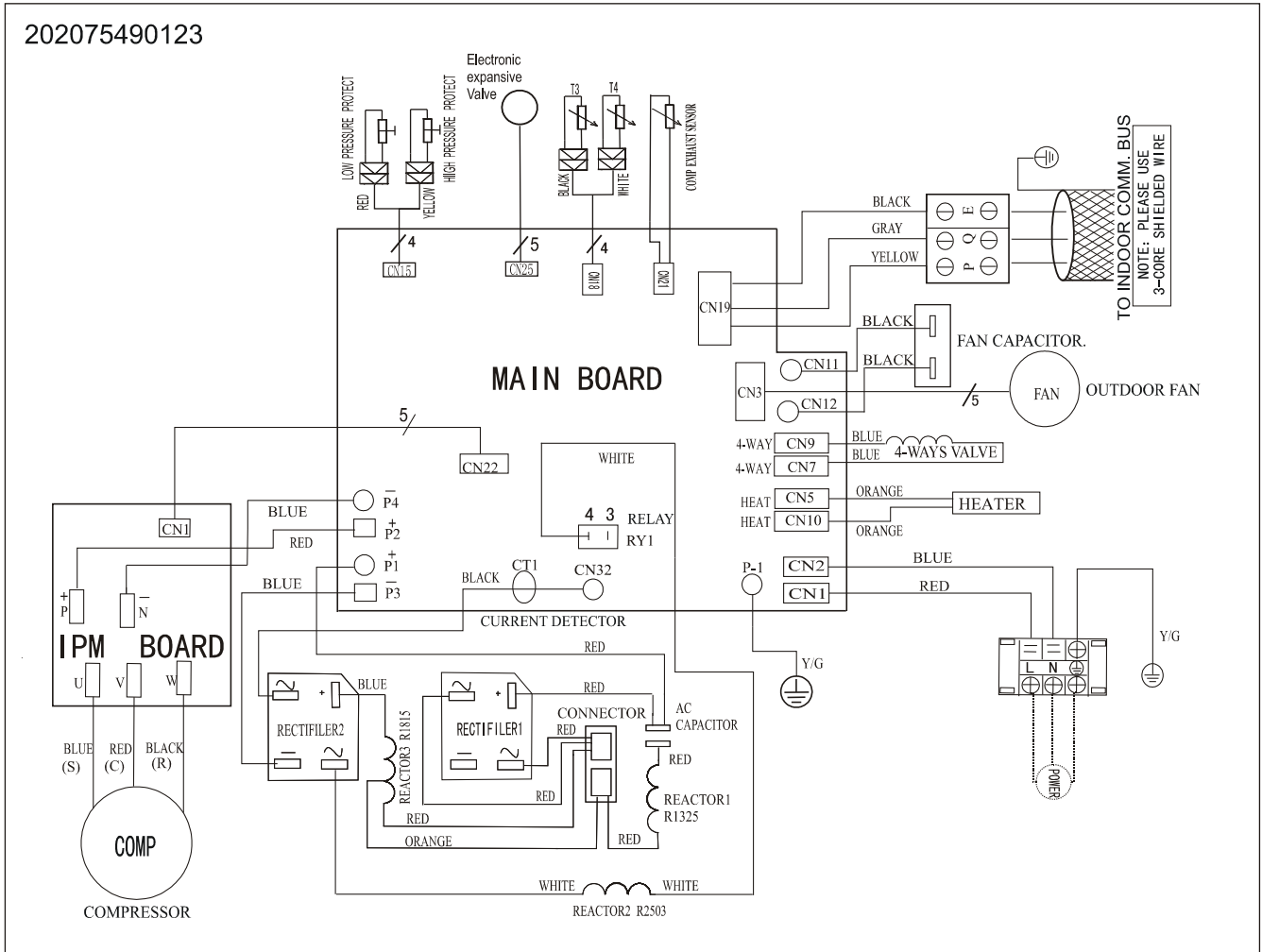

MOU-36HDN1-Q(220075501600)

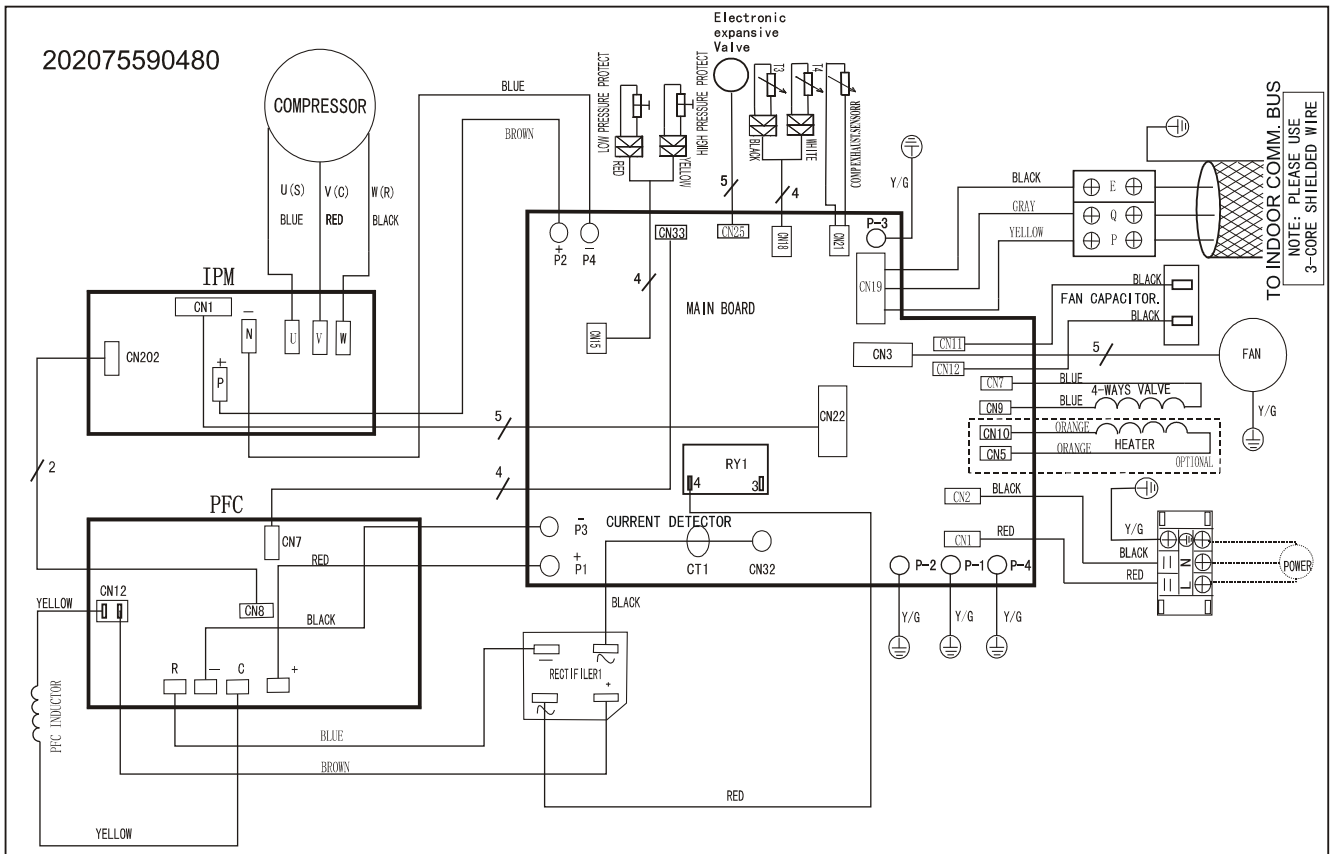





MOU-48HDN1-Q

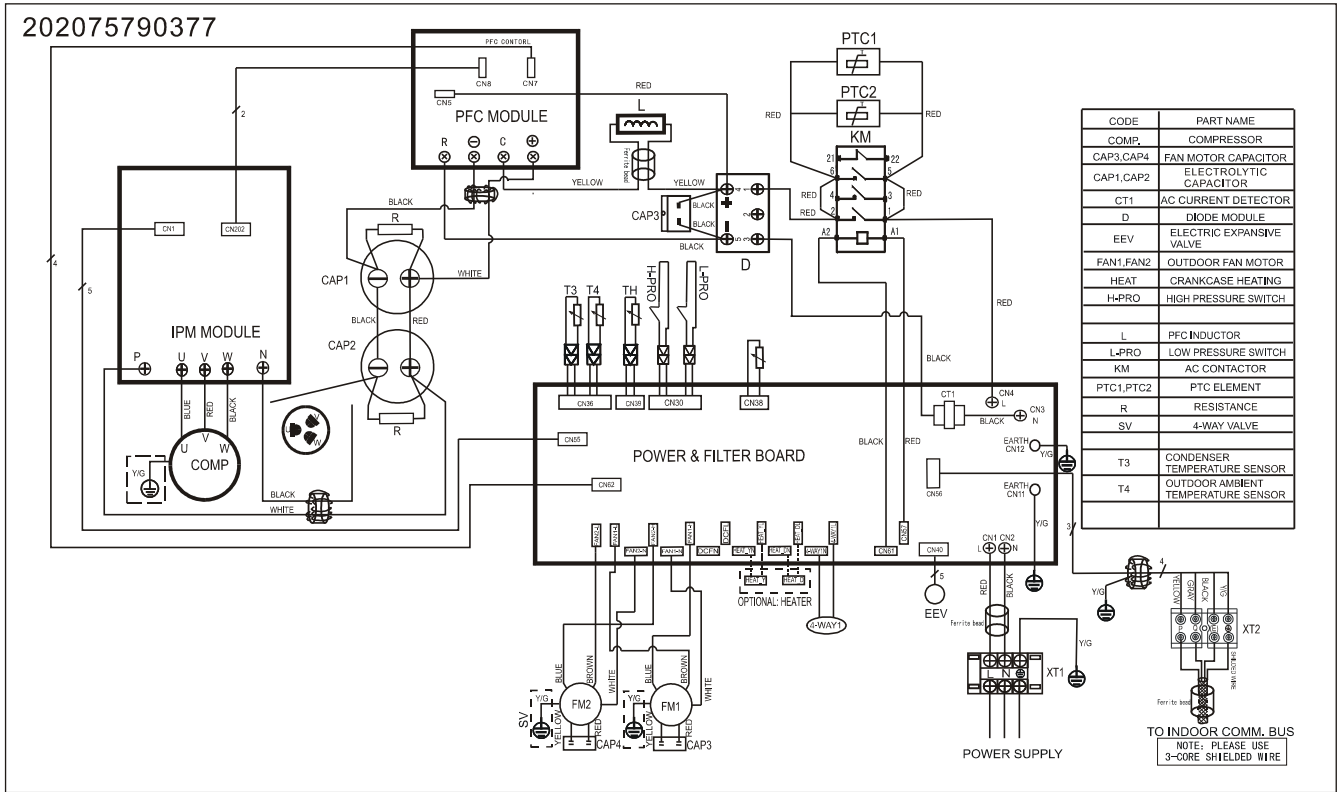

MOU-36HDN1-R

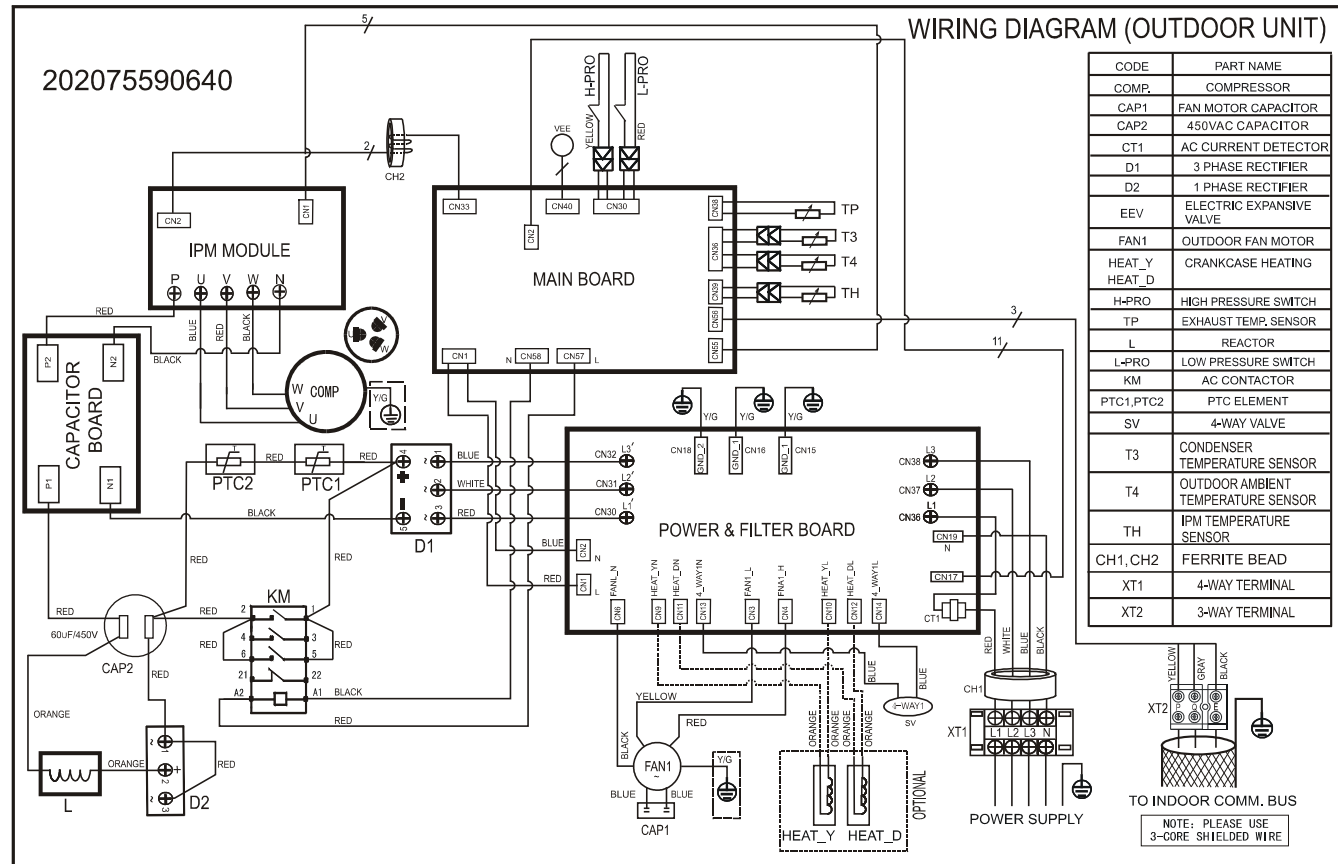

MOU-48HDN1-R MOU-60HDN1-R

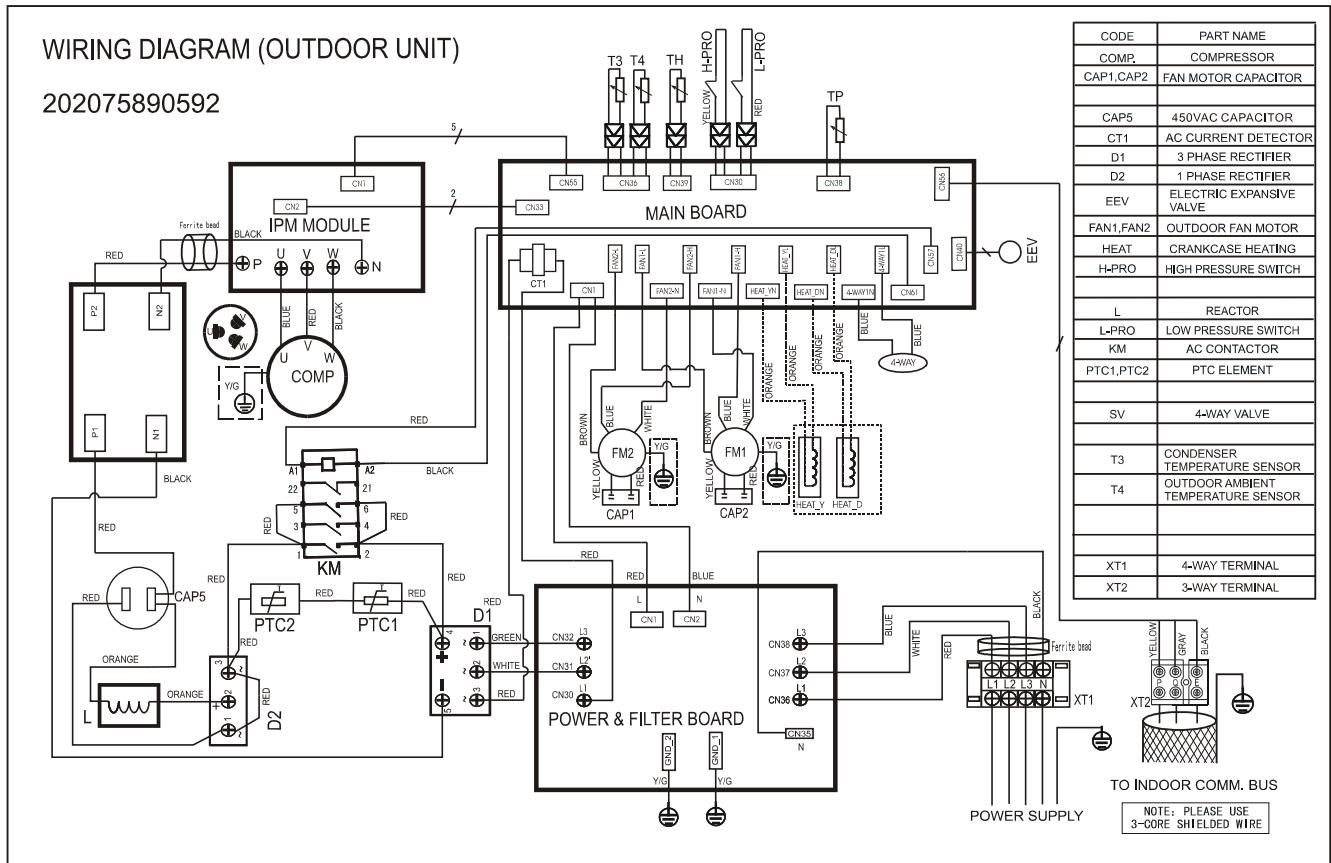

## 5. Electric Characteristics

Model	Outdoor Unit			
	Hz	Voltage	Min.	Max.
MOU-12HDN1-Q	50	220-240	198	254
MOU-18HDN1-Q	50	220-240	198	254
MOU-24HDN1-Q	50	220-240	198	254
MOU-30HDN1-Q	50	220-240	198	254
MOU-36HDN1-Q	50	220-240	198	254
MOU-36HDN1-R	50	380-415	342	440
MOU-48HDN1-Q	50	220-240	198	254
MOU-48HDN1-R	50	380-415	342	440
MOU-60HDN1-R	50	380-415	342	440

## 6. Operation Limits

12k

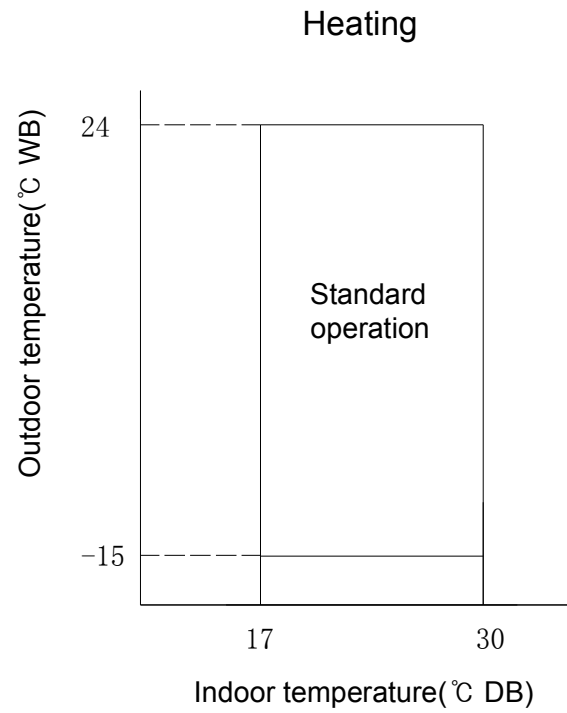
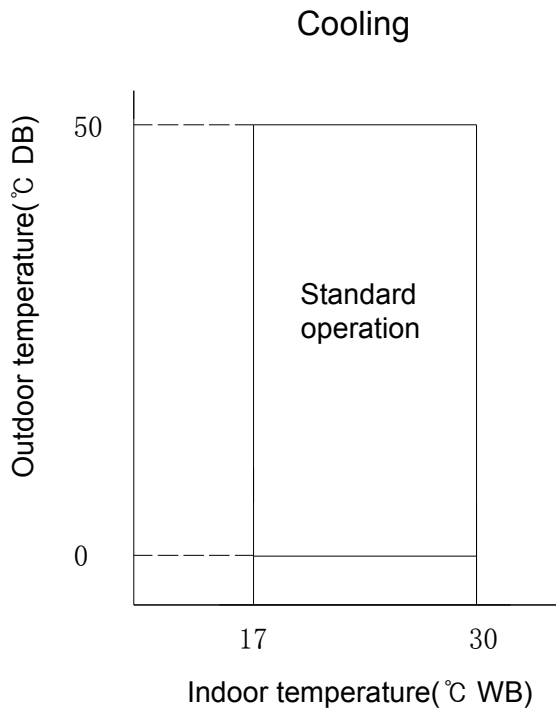

18-60k

### Cooling

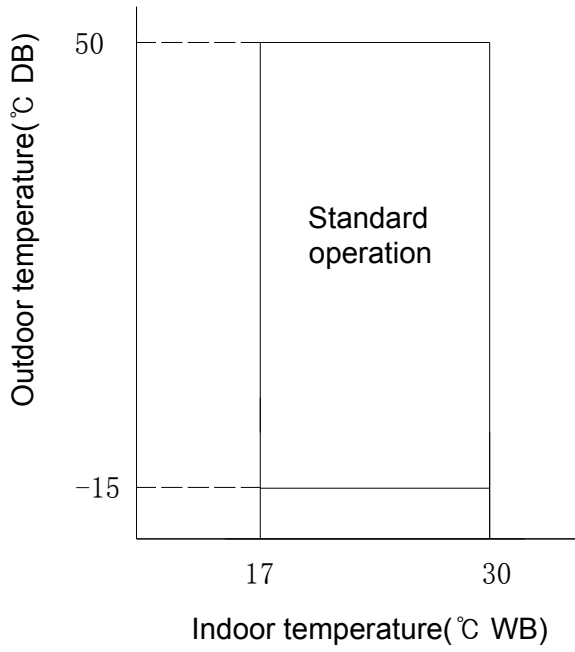

### Heating

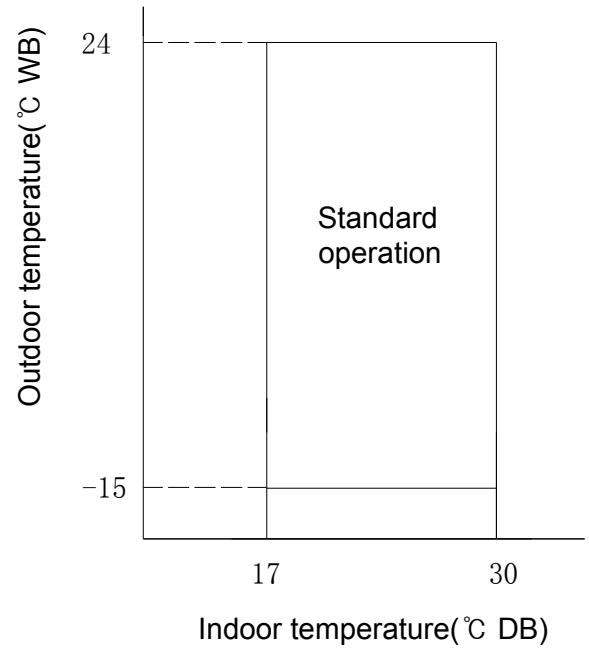

## 7. Sound Levels

Outdoor unit

Microphone

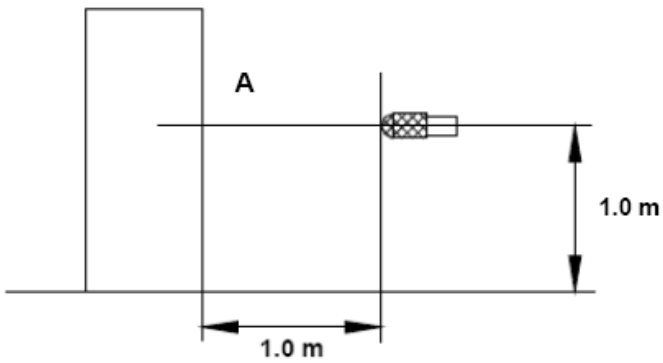

Model	Noise level dB(A)
	H
MOU-12HDN1-Q	48
MOU-18HDN1-Q	51
MOU-24HDN1-Q(220075301400)	54
MOU-24HDN1-Q(220075301401)	59
MOU-30HDN1-Q	55
MOU-36HDN1-Q	55
MOU-36HDN1-R	63
MOU-48HDN1-Q	59/54
MOU-48HDN1-R	62
MOU-60HDN1-R	63

## 8. Point Check Function

There is a check switch in outdoor PCB.

Push the switch SW1 to check the states of unit when the unit is running. The digital display tube will display the follow procedure when push SW1 each time.

For units except model MOU-12HDN1-Q:

	Display	Remark		
00	Normal display	Display running frequency, running state or malfunction code		
01	Indoor unit capacity demand code	Actual data*HP*10 If capacity demand code is higher than 99, the digital display tube will show single digit and tens digit. (For example, the digital display tube show "5.0",it means the capacity demand is 15. the digital display tube show "60",it means the capacity demand is 6.0)		
02	Amendatory capacity demand code			
03	The frequency after the capacity requirement transfer			
04	The frequency after the frequency limit			
05	The frequency of sending to 341			
06	Indoor unit evaporator outlet temp.(T2)	If the temp. is lower than 0 degree, the digital display tube will show "0".If the temp. is higher than 70 degree, the digital display tube will show "70".		
07	Condenser pipe temp.(T3)	If the temp. is lower than -9 degree, the digital display tube will show "-9".If the temp. is higher than 70 degree, the digital display tube will show "70". If the indoor unit is not connected, the digital display tube will show: "—"		
08	Outdoor ambient temp.(T4)			
09	Compressor discharge temp.(Tp)	The display value is between 30~120 degree. If the temp. is lower than 30 degree, the digital display tube will show "30".If the temp. is higher than 99 degree, the digital display tube will show single digit and tens digit. (For example, the digital display tube show "0.5",it means the compressor discharge temp. is 105 degree. the digital display tube show "1.6",it means the compressor discharge temp. is 116 degree)		
10	AD value of current	The display value is hex number.  Off:0, Fan only 1,Cooling:2, Heating:3, Forced cooling:4		
11	AD value of voltage			
12	Indoor unit running mode code			
13	Outdoor unit running mode code			
14	EXV open angle	Actual data/4. If the value is higher than 99, the digital display tube will show single digit and tens digit. For example ,the digital display tube show "2.0",it means the EXV open angle is $120 \times 4 = 480p.$ )		
15	Frequency limit symbol	Bit7	0	The display value is hex number. For example, the digital display tube show 2A,then Bit5=1, Bit3=1, Bit1=1. It means frequency limit caused by T4,T3 and current.
		Bit6	0	
		Bit5	Frequency limit caused by T4.	
		Bit4	Frequency limit caused by T2.	
		Bit3	Frequency limit caused by T3.	
		Bit2	Frequency limit caused by Tp.	
		Bit1	Frequency limit caused by current	
		Bit0	Frequency limit caused by voltage	

## 9. Troubleshooting

### 10.1 Indoor unit malfunction

#### 10.1.1 Display board

##### Compact 4-way cassette

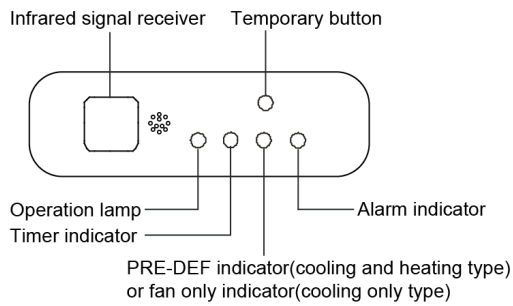

##### Normal 4-way cassette

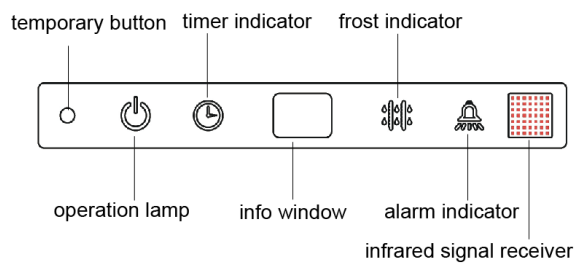

##### Duct

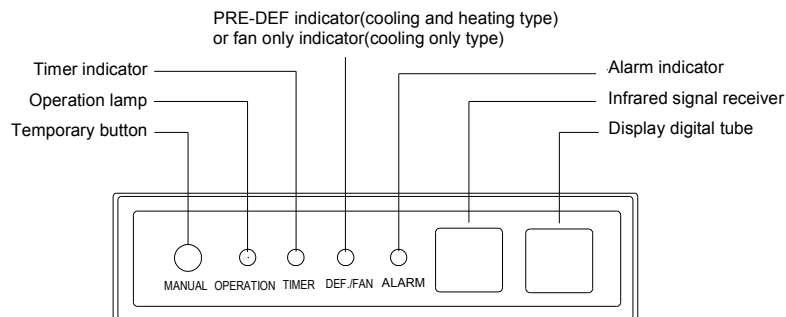



### 10.1.2 Troubleshooting

#### For compact 4-way cassette(12K)

NO.	Malfunction	Running lamp	Timer lamp	Defrosting lamp	Alarm lamp
1	Communication malfunction between indoor and outdoor units.	X	☆	X	X
2	Open or short circuit of T1 temperature sensor	☆	X	X	X
3	Open or short circuit of T2 temperature sensor	X	X	☆	X
4	Full-water malfunction	X	X	X	☆
5	EEPROM malfunction	☆	☆	X	X
6	IPM module protection	☆	X	X	O
7	Open or short circuit of T3 temperature sensor	☆	O	X	X
8	Outdoor unit voltage protection	☆	O	X	O
9	Outdoor unit over-current protection	☆	☆	X	☆

O(light) X(off) ☆(flash)

#### For compact 4-way cassette(18K)

NO.	Malfunction	Running lamp	Timer lamp	Defrosting lamp	Alarm lamp
1	Communication malfunction between indoor and outdoor units.	X	☆	X	X
2	Open or short circuit of T1 or T2 temperature sensor	☆	X	X	X
4	Full-water malfunction	X	X	X	☆
5	Collision model malfunction	X	X	☆	X
6	Outdoor unit malfunction	X	X	X	◎

X(off) ☆(flash at 5Hz) ◎(flash at 0.5Hz)

#### For Normal 4-way cassette(24K-30K), For Duct type(18-30K)

NO.	Malfunction	Running lamp	Timer lamp	Defrosting lamp	Alarm lamp	Display(nixie tube)
1	Communication malfunction between indoor and outdoor units.	X	☆	X	X	E1
2	Open or short circuit of T1 temperature sensor	☆	X	X	X	E2
3	Open or short circuit of T2 temperature sensor	☆	X	X	X	E3
4	Open or short circuit of T2B temperature sensor	☆	X	X	X	E4
5	Full-water malfunction	X	X	X	☆	EE
6	EEPROM malfunction	◎	X	X	X	E7
7	Outdoor unit malfunction	X	X	X	◎	Ed

X(off) ☆(flash at 5Hz) ◎(flash at 0.5Hz)

#### For Normal 4-way cassette(36K-60K), Duct type(36K-60K)

NO.	Malfunction	Running lamp	Timer lamp	Defrosting lamp	Alarm lamp	Display(nixie tube)
1	Communication malfunction between indoor and outdoor units.	X	☆	X	X	E1
2	Open or short circuit of T1 temperature sensor	☆	X	X	X	E2
3	Open or short circuit of T2 temperature sensor	☆	X	X	X	E3
4	Open or short circuit of T2B temperature sensor	☆	X	X	X	E4
5	Full-water malfunction	X	X	X	☆	EE

6	EEPROM malfunction	X	X	☆	X	E7
7	Outdoor unit malfunction	X	X	X	◎	Ed
X(off) ☆(flash at 5Hz) ◎(flash at 0.5Hz)						

## 10.2 Outdoor unit malfunction

Display	Malfunction or Protection
E0	EEPROM malfunction
E2	Communication malfunction between indoor IC and outdoor IC
E3	Communication malfunction in outdoor IC and DSP
E4	Open or short circuit of T3 temperature sensor
E5	Voltage protection of compressor
E6	PFC module protection (Only for 36K, 48K with 1 phase)
P0	Top temperature protection of compressor
P1	High pressure protection
P2	Low pressure protection
P3	Current protection of compressor
P4	Discharge temperature protection of compressor
P5	High temperature protection of condenser
P6	Module protection
P7	High temperature protection of evaporator

### 10.3 Solving steps for typical malfunction

#### 10.3.1 For the indoor unit

##### 10.3.1.1 Open or short circuit of T1 temperature sensor

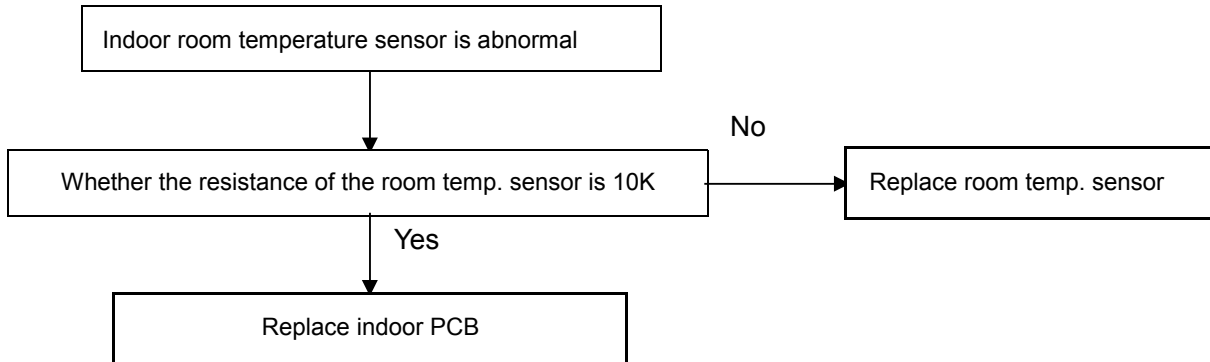

##### 10.3.1.2. Open or short circuit of T2 temperature sensor

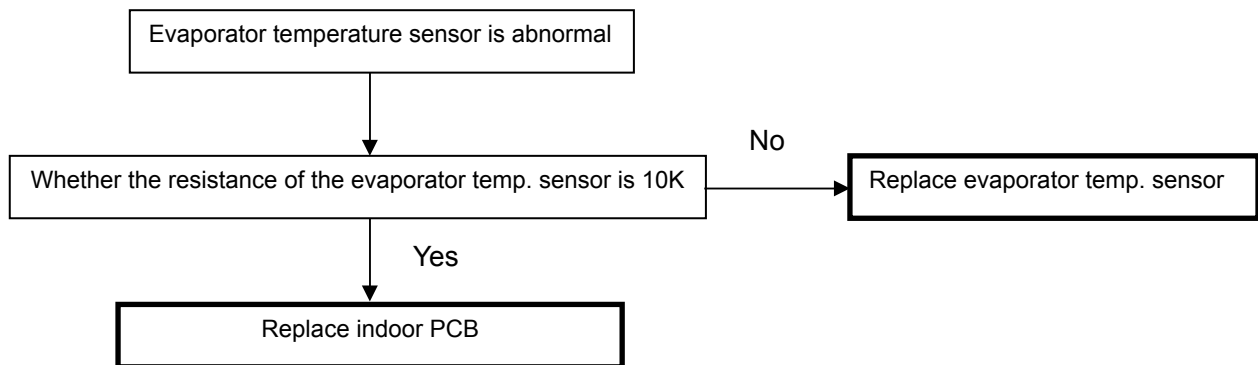

##### 10.3.1.3. Open or short circuit of T3 temperature sensor

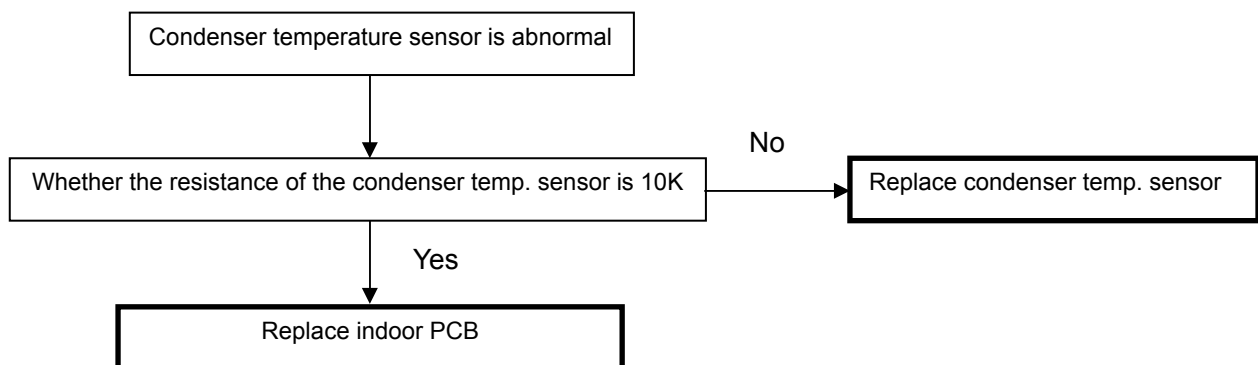

10.3.1.4. Outdoor unit malfunction

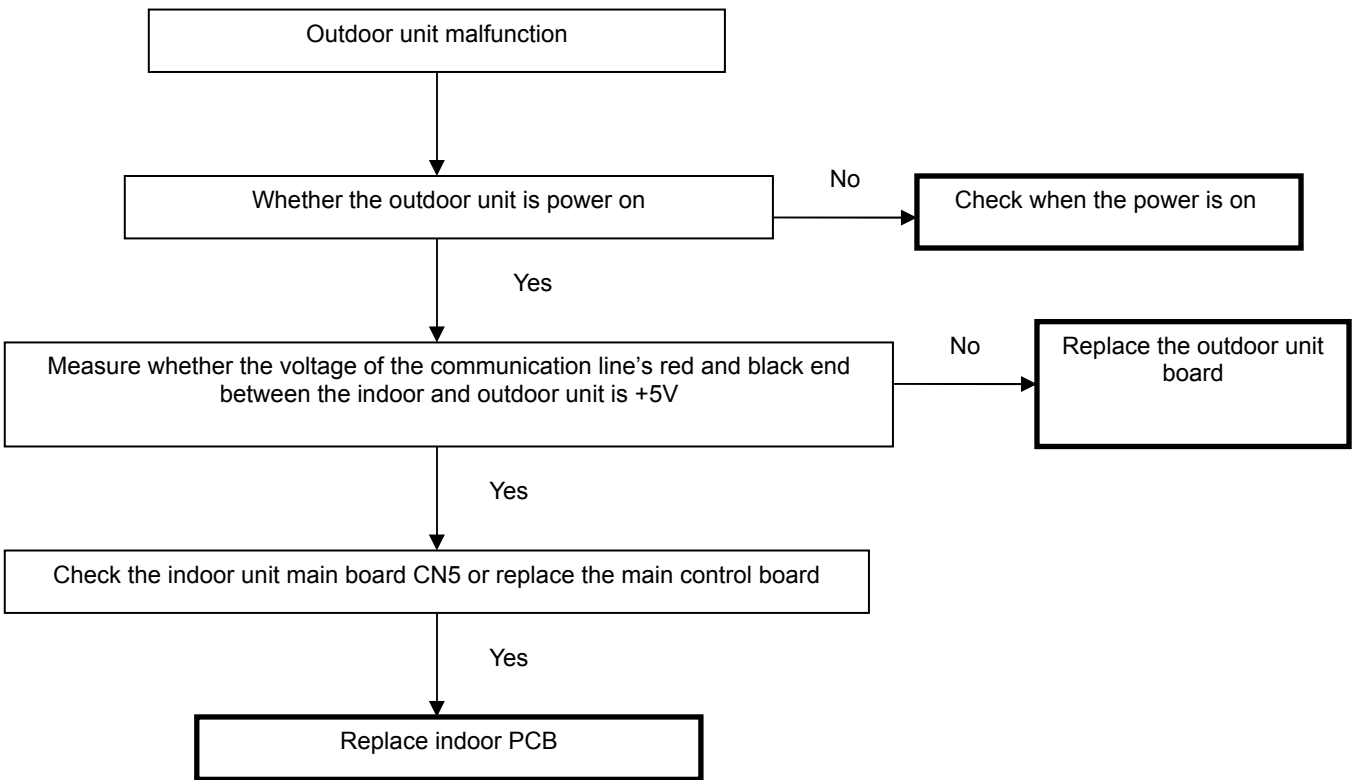

10.3.1.5. EEPROM malfunction

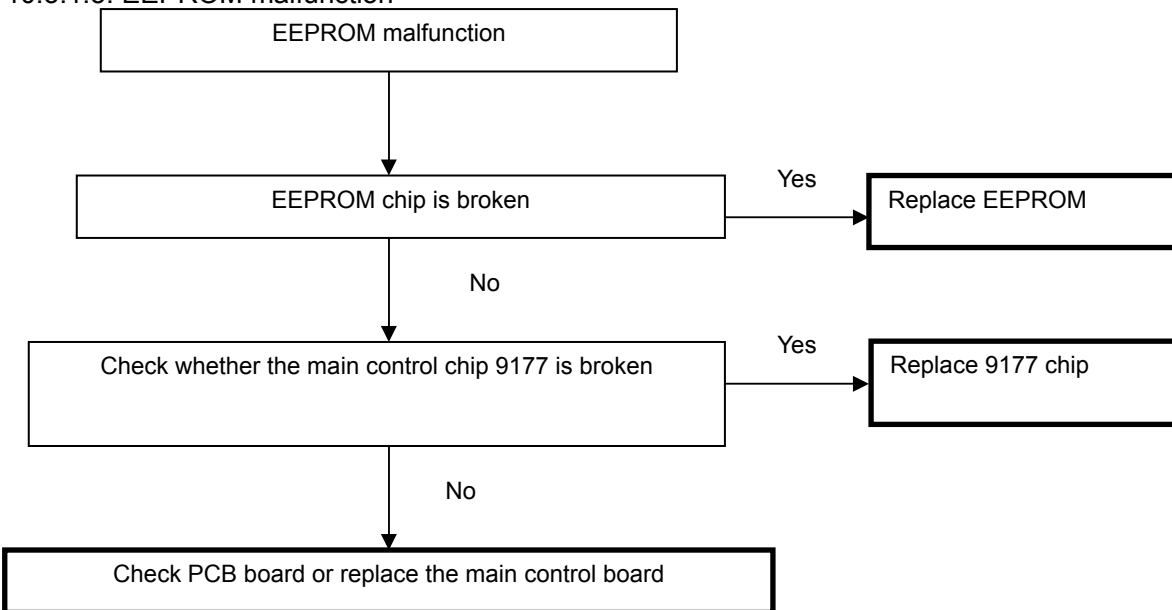

10.3.1.6. Full-water malfunction

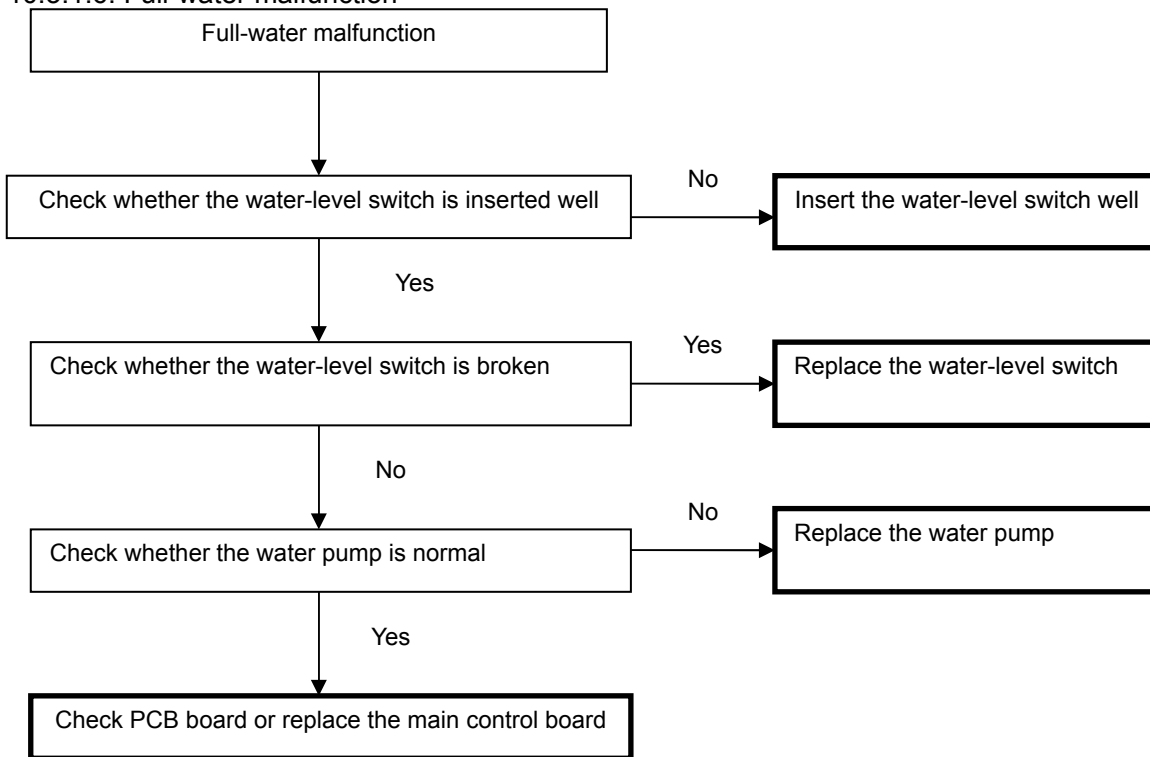

10.3.2 For the outdoor unit

10.3.2.1. E0 malfunction

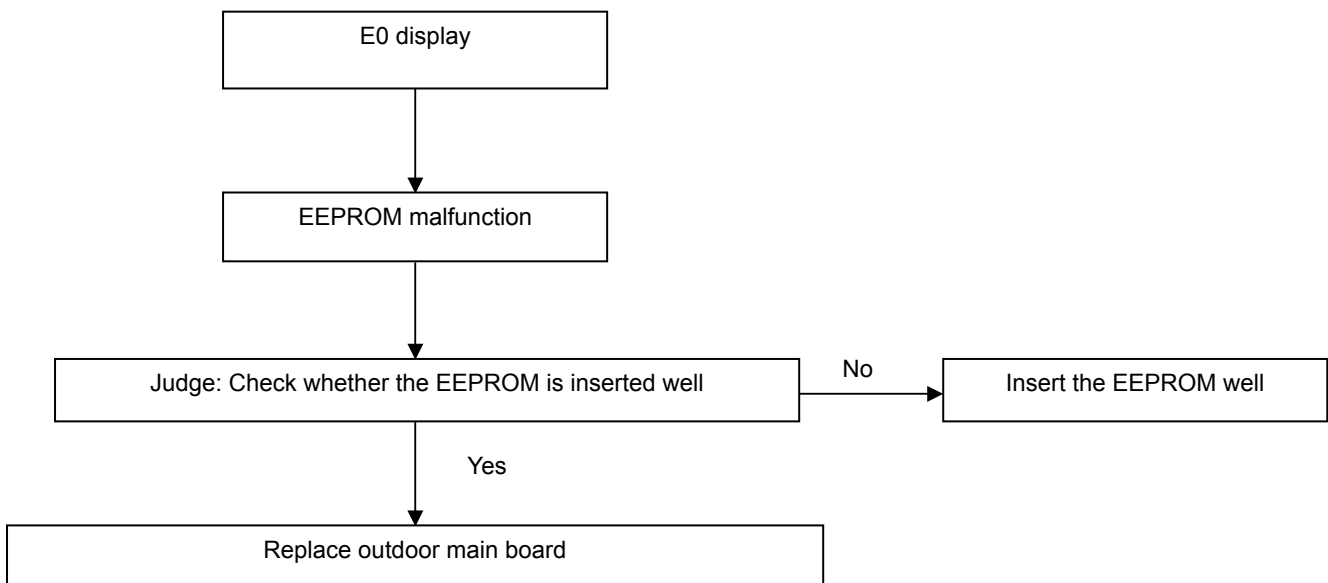

10.3.2.2. E2 malfunction

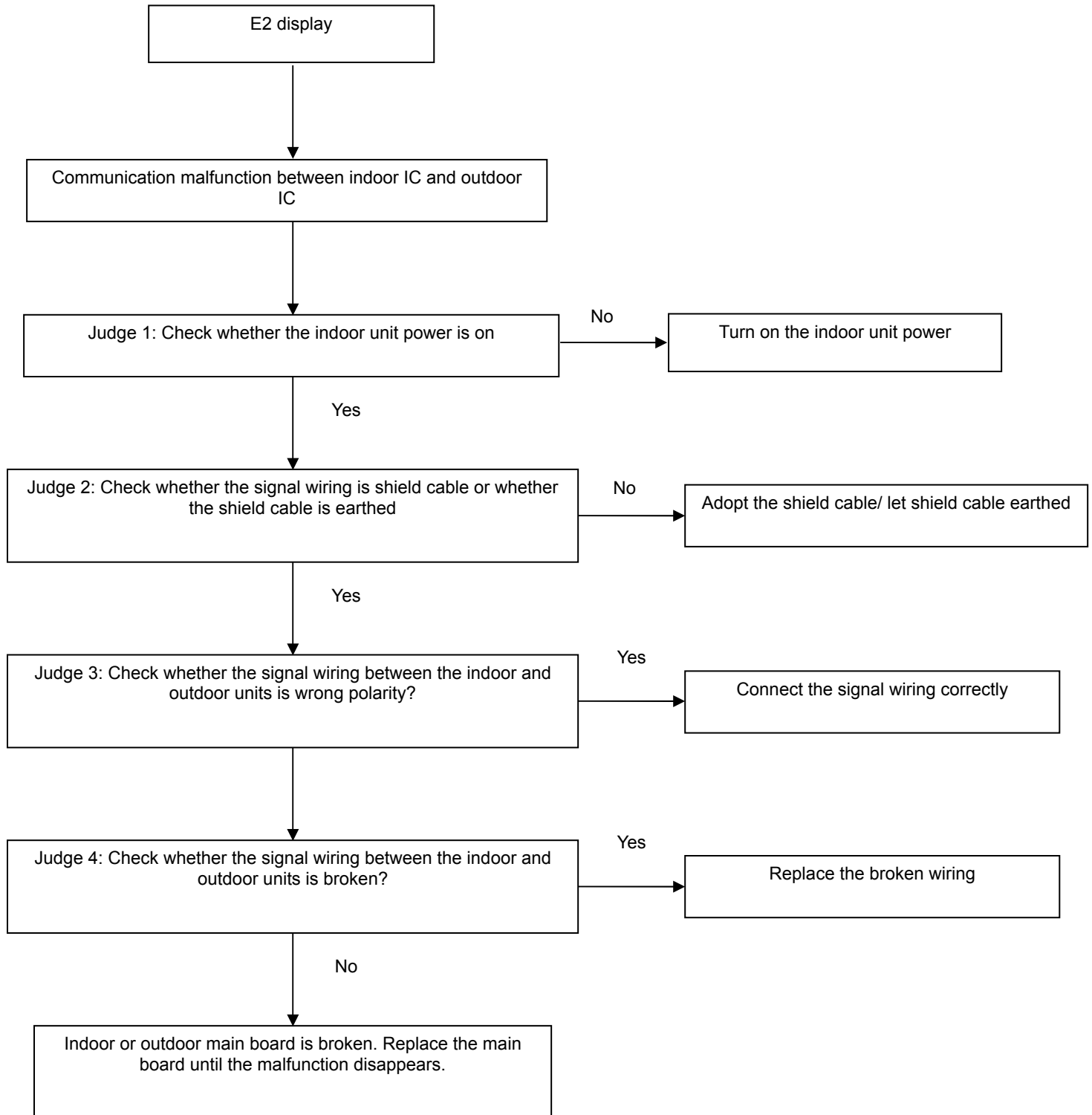

10.3.2.3. E3 malfunction (For 18K & 24K & 30K)

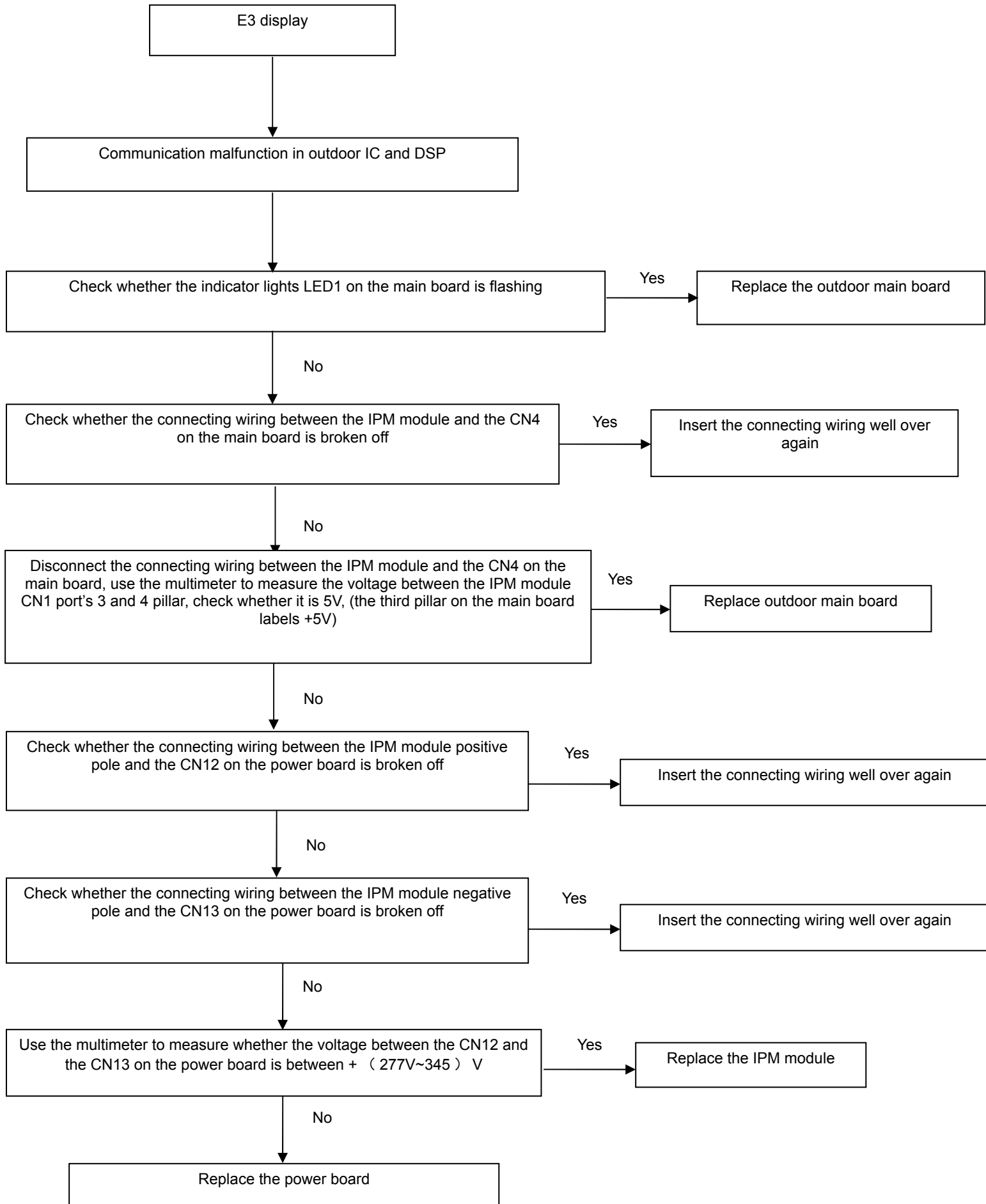

10.3.2.4. E3 malfunction (For 36K & 48K & 60K)

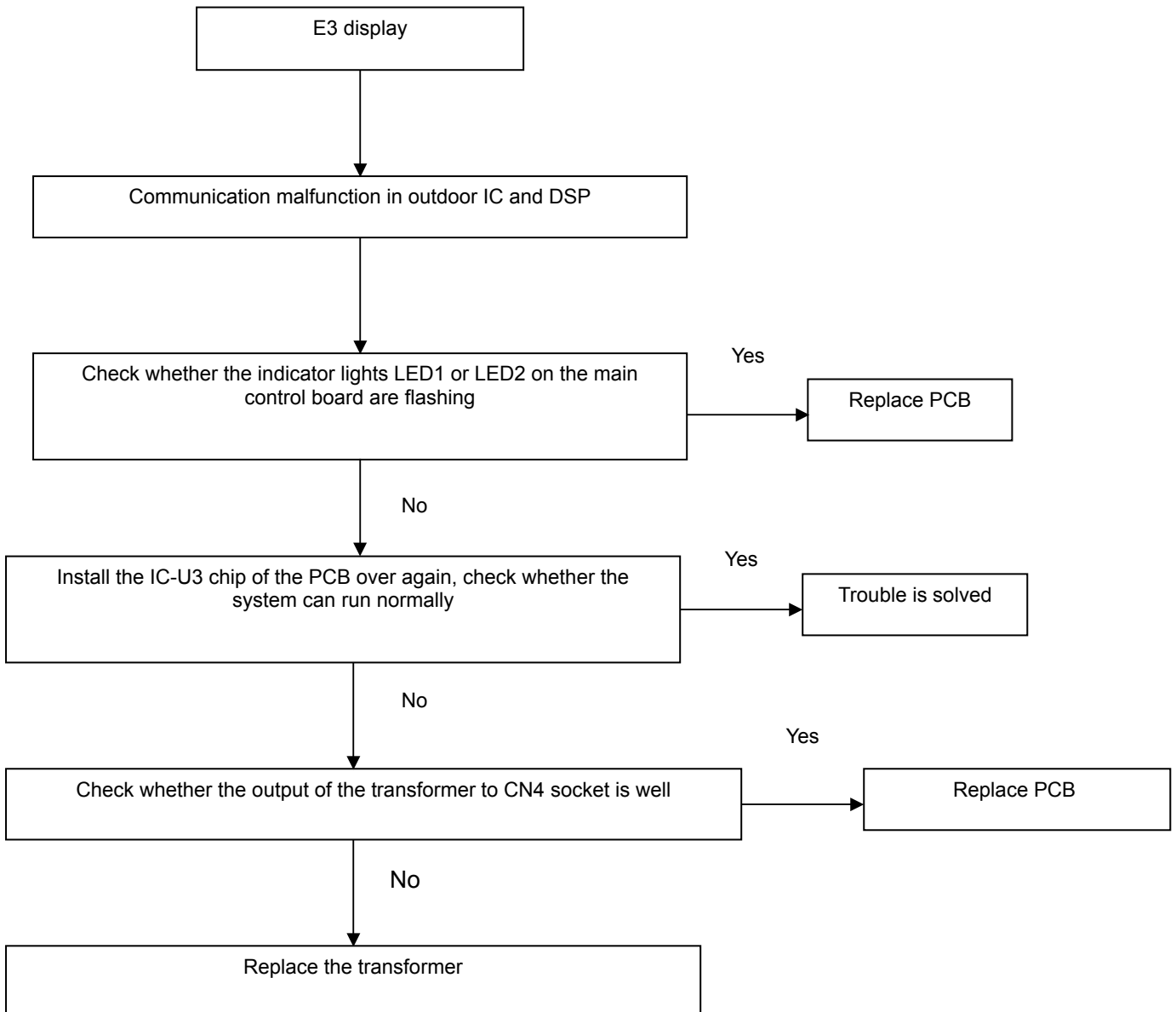



10.3.2.5. E4 malfunction

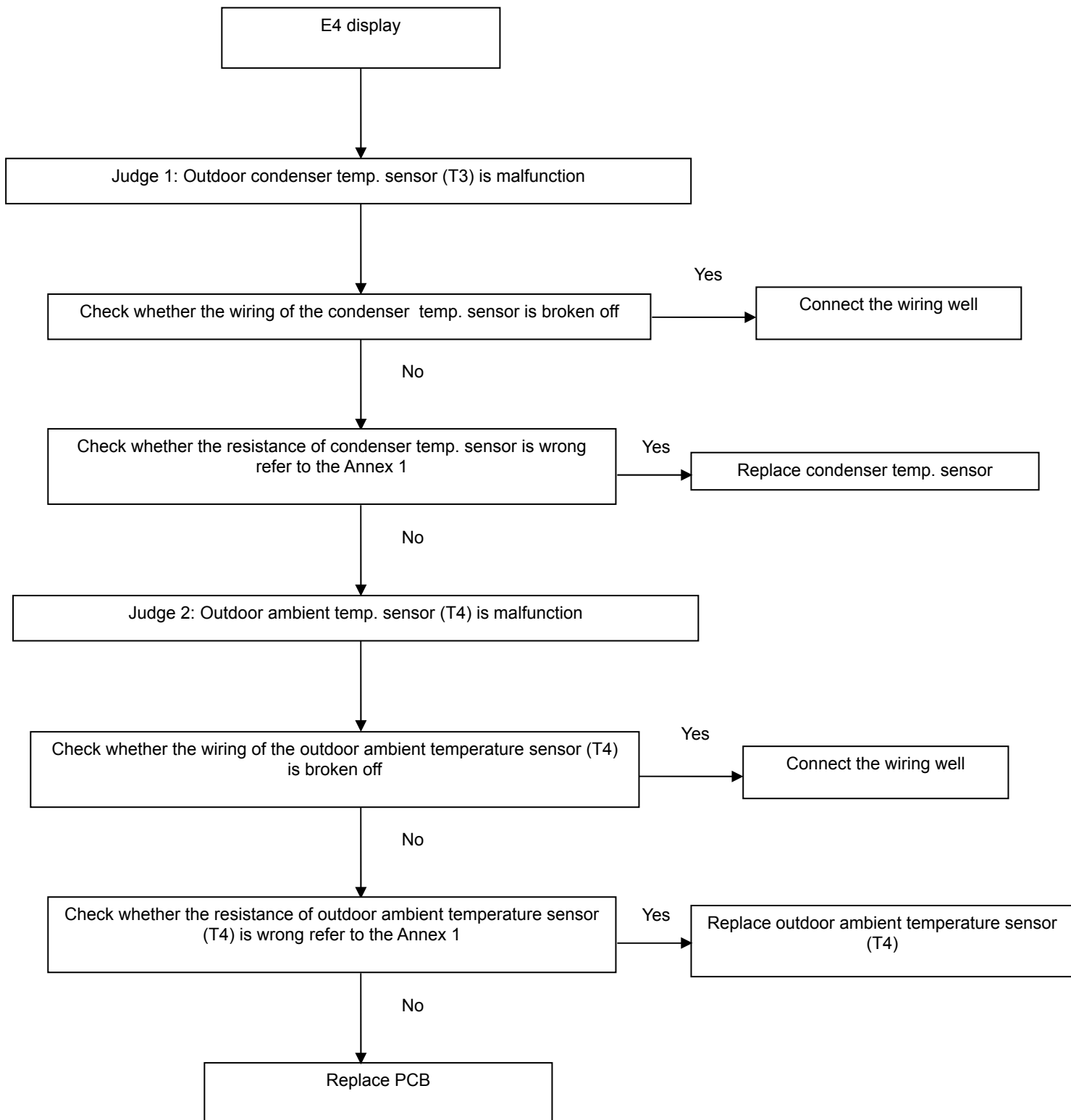

10.3.2.6. E5 malfunction

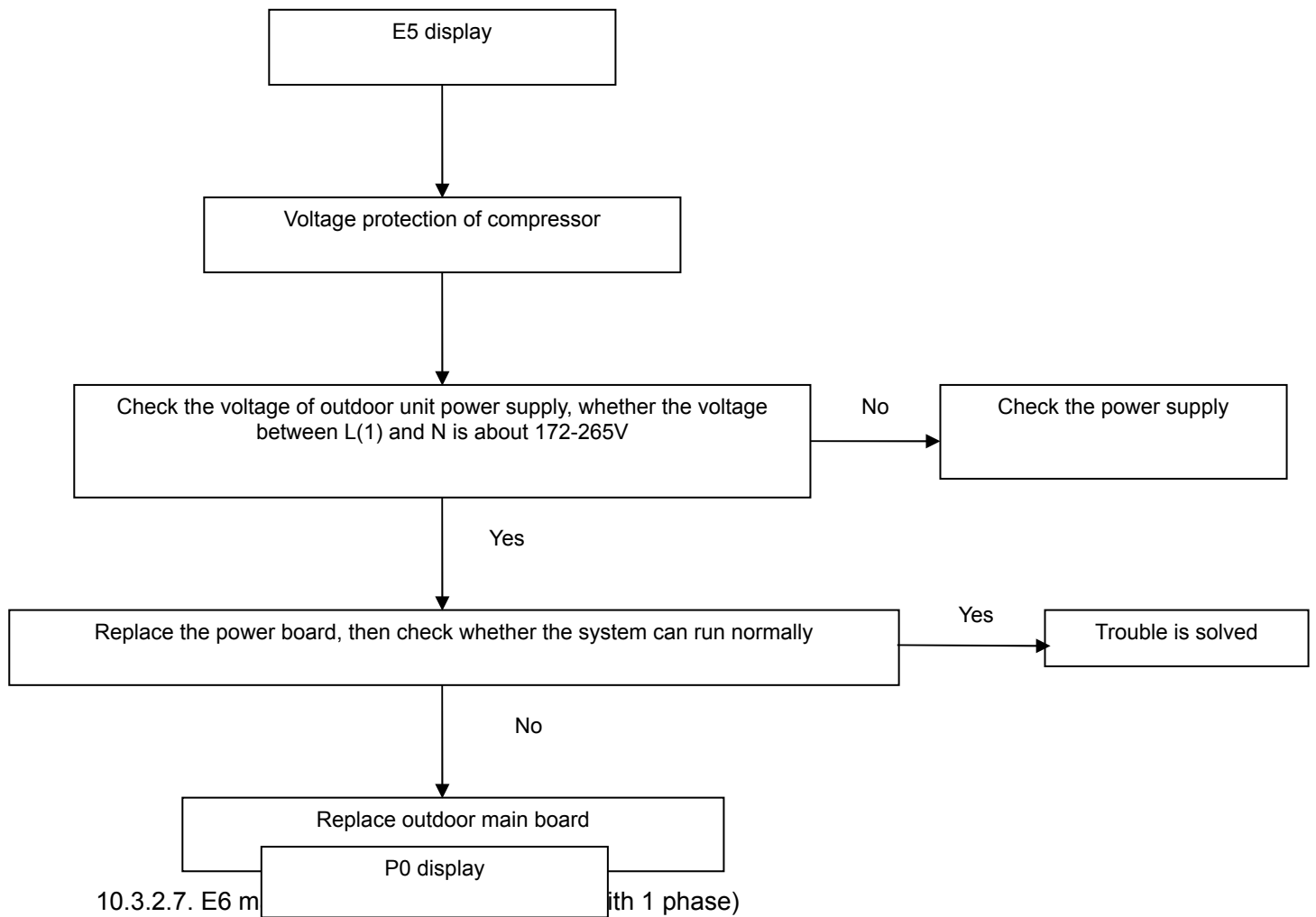

10.3.2.7. E6 malfunction (with 1 phase)

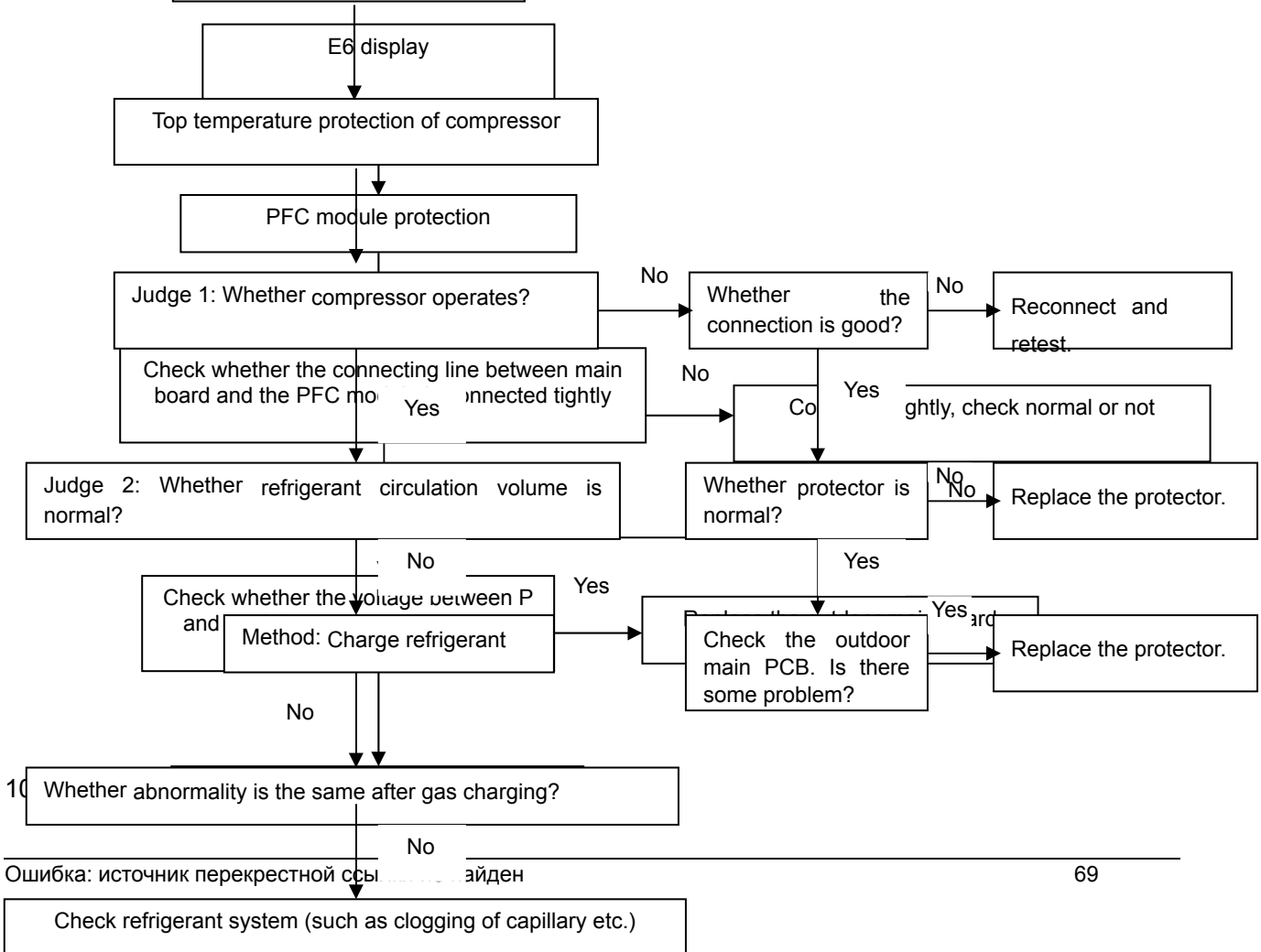

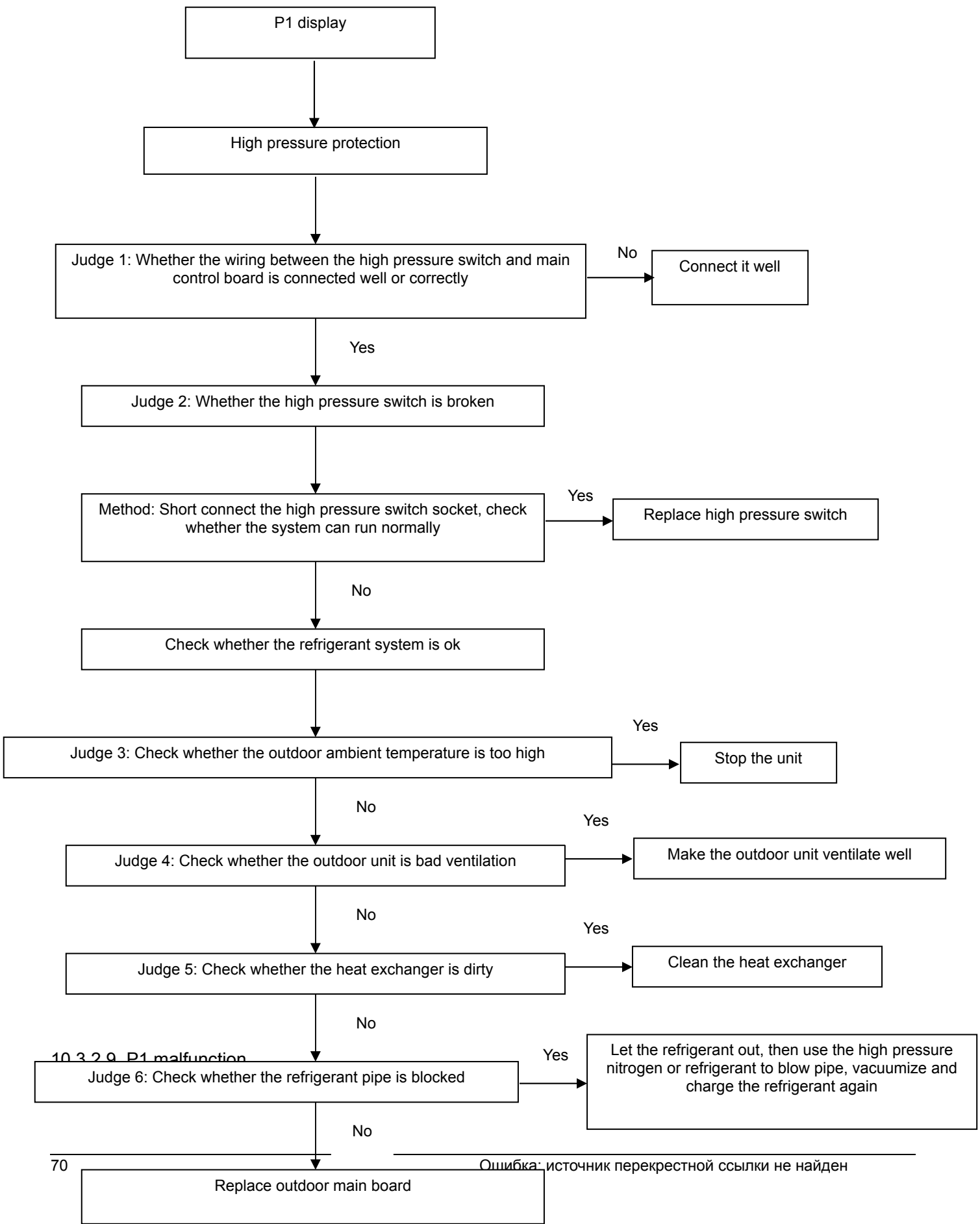



10.3.2.10. P2 malfunction

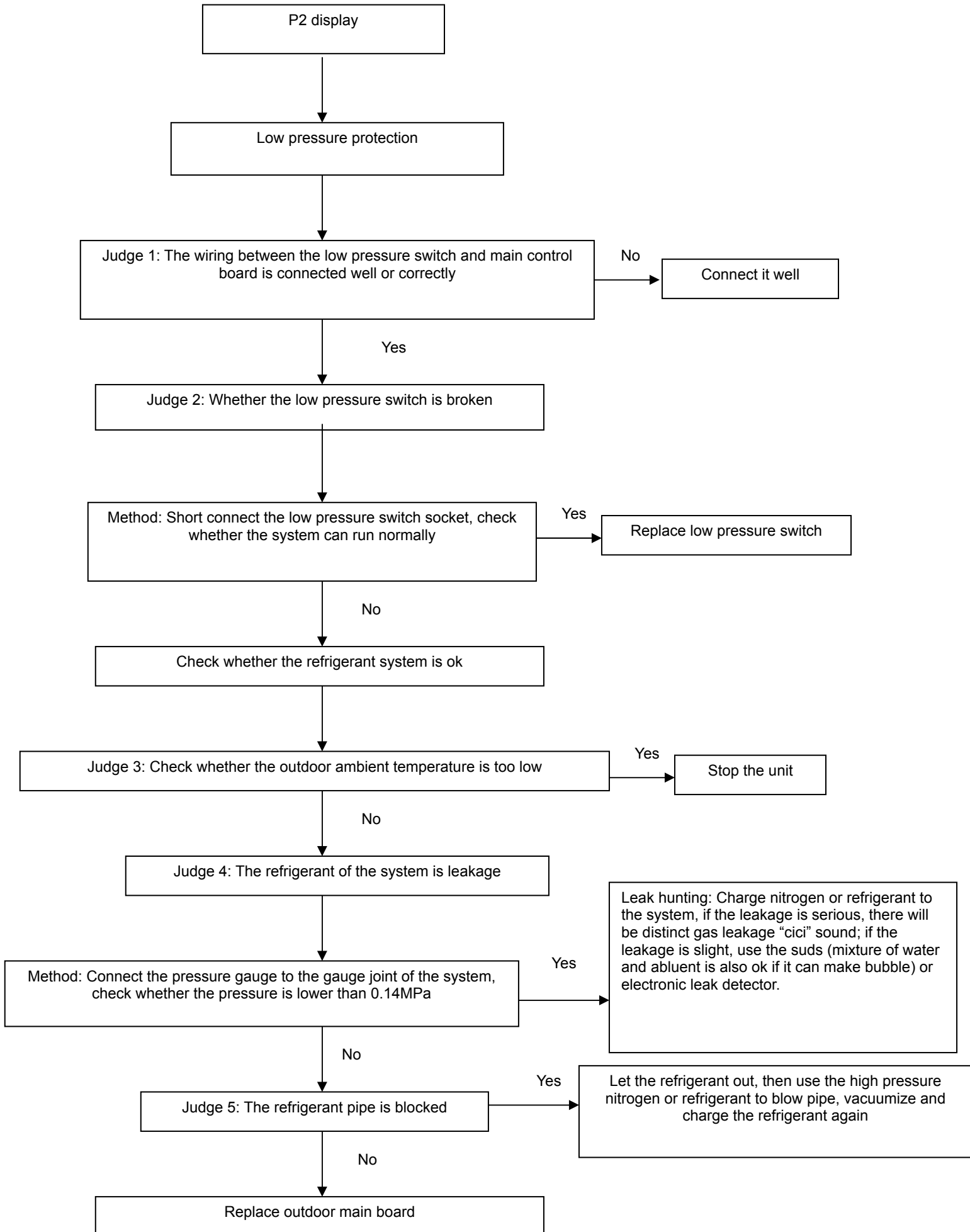

10.3.2.11. P3 malfunction

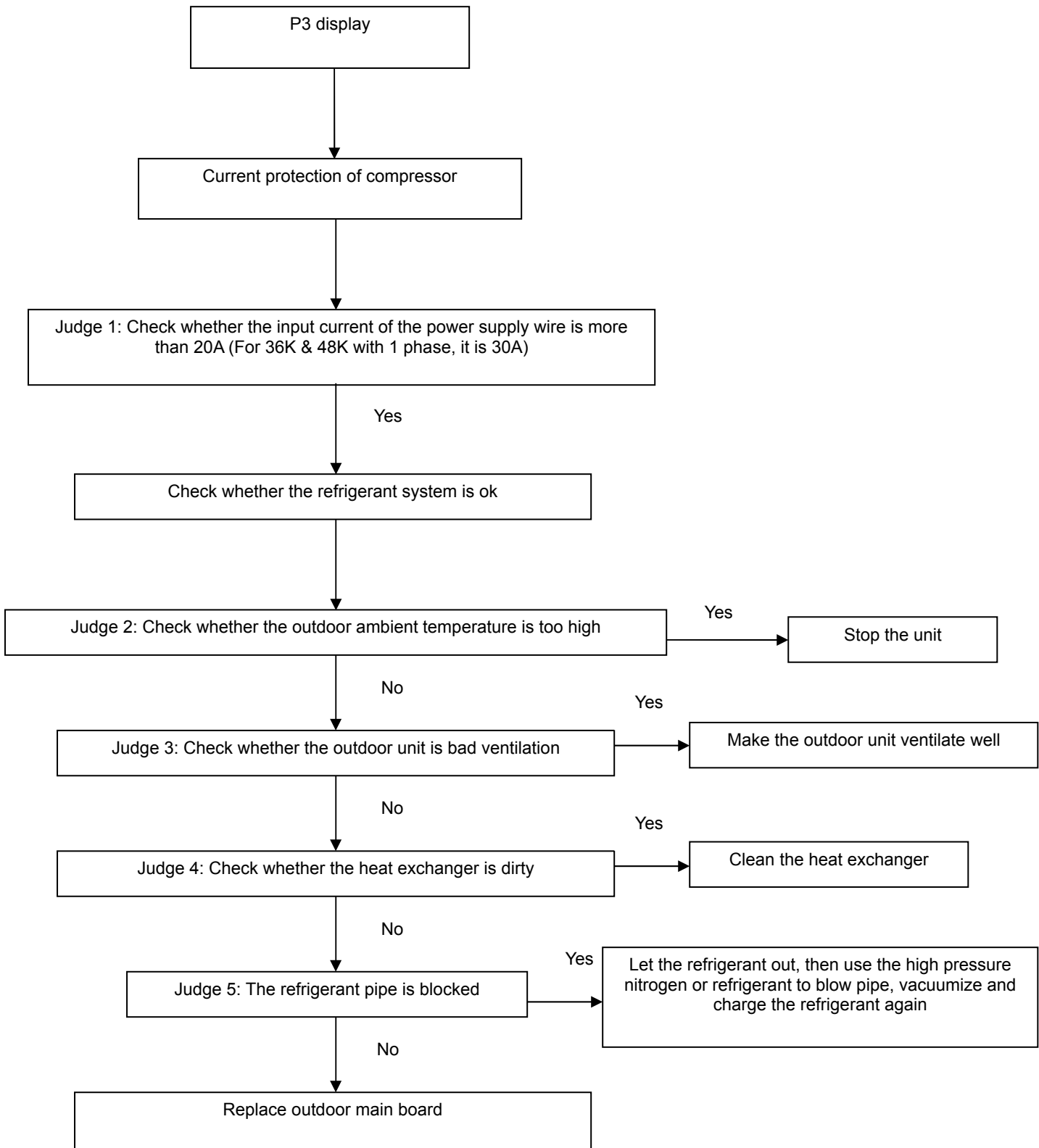

10.3.2.12. P4 malfunction

When compressor discharge temperature is higher than 115°C, the unit will stop, and unit runs again when compressor discharge temperature is lower than 90°C.

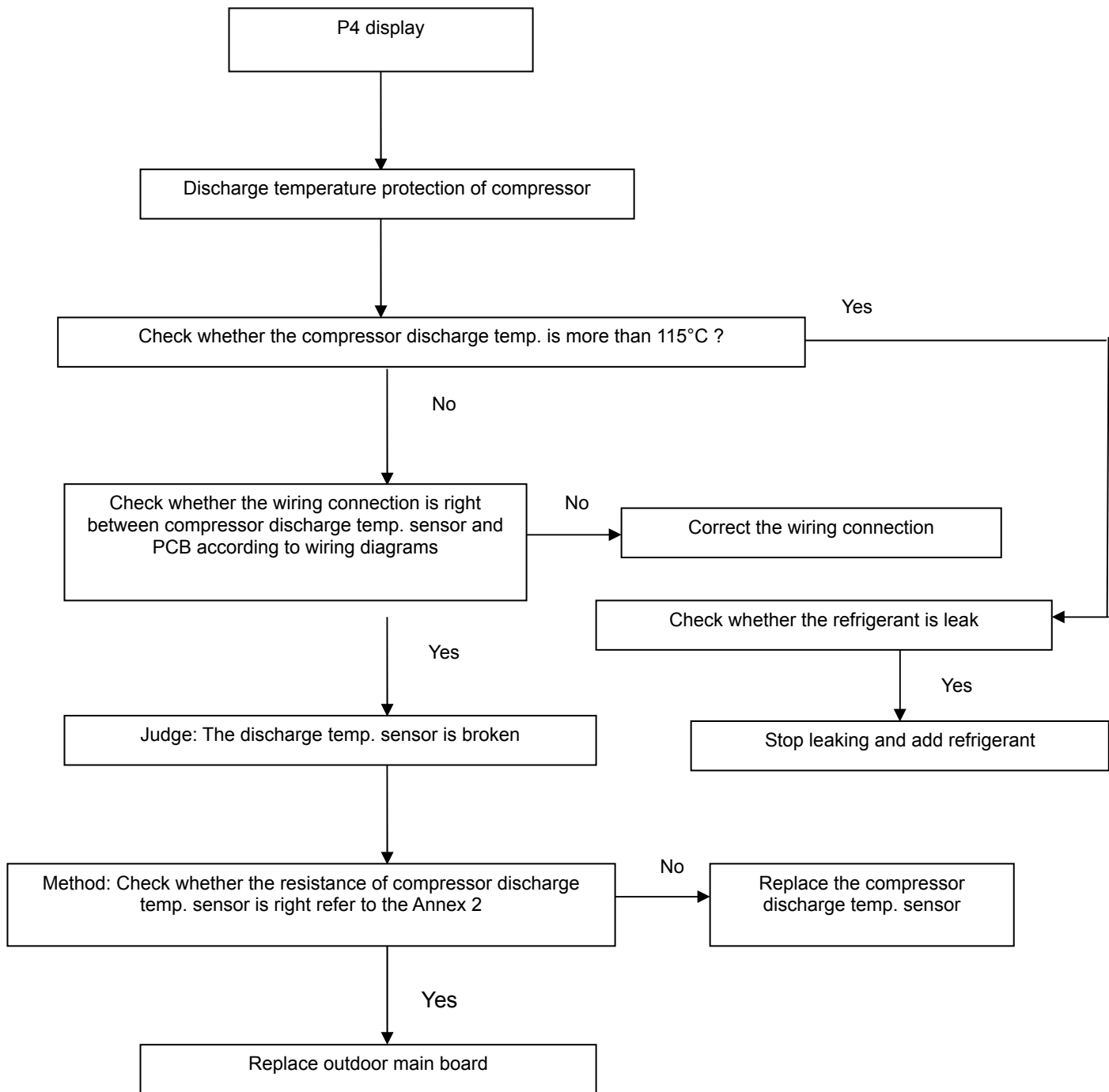

10.3.2.13. P5 malfunction

When condenser high temp. is more than 65°C, the unit will stop, and unit runs again when outdoor pipe temp. less than 52°C.

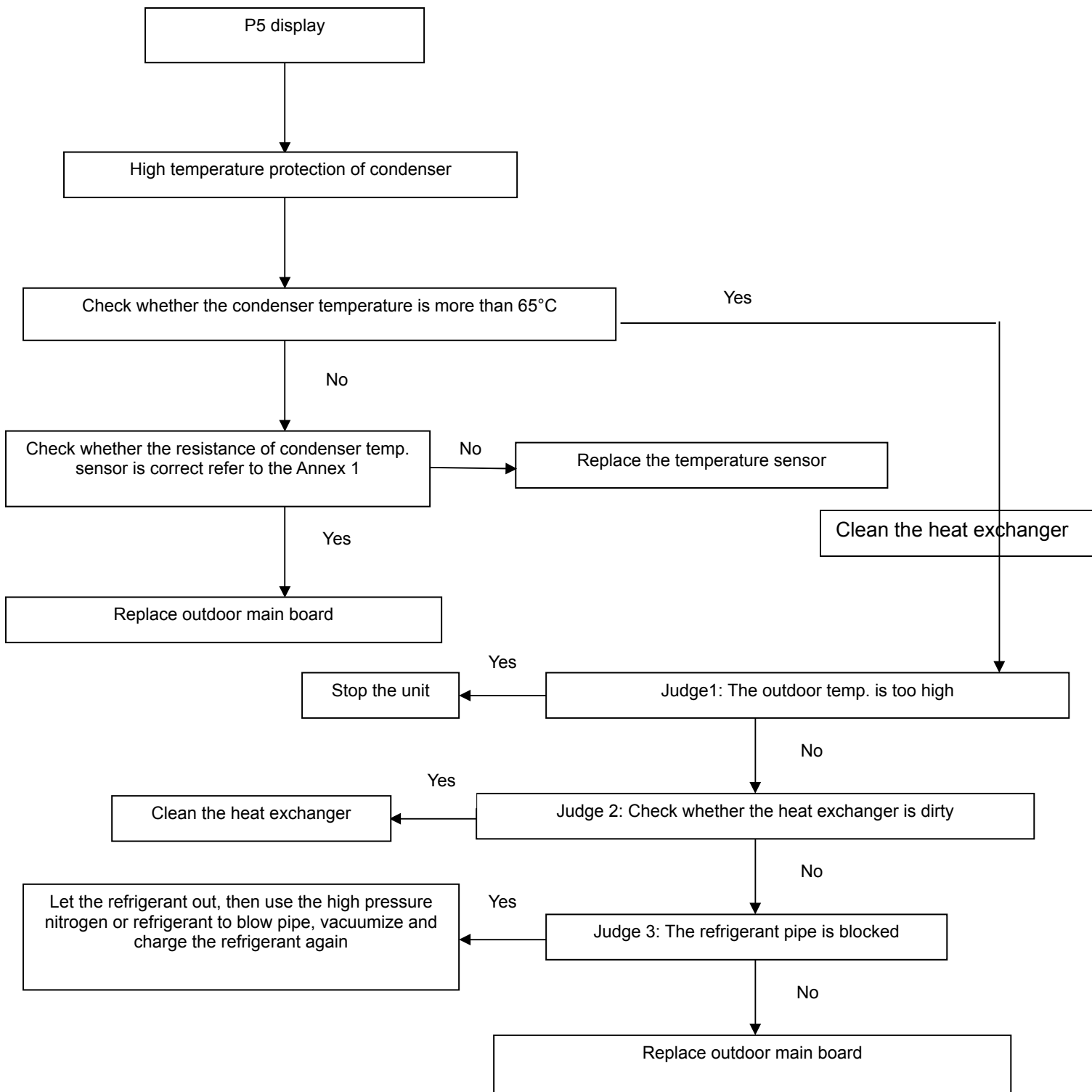



10.3.2.14. P6 malfunction (For single phase units)

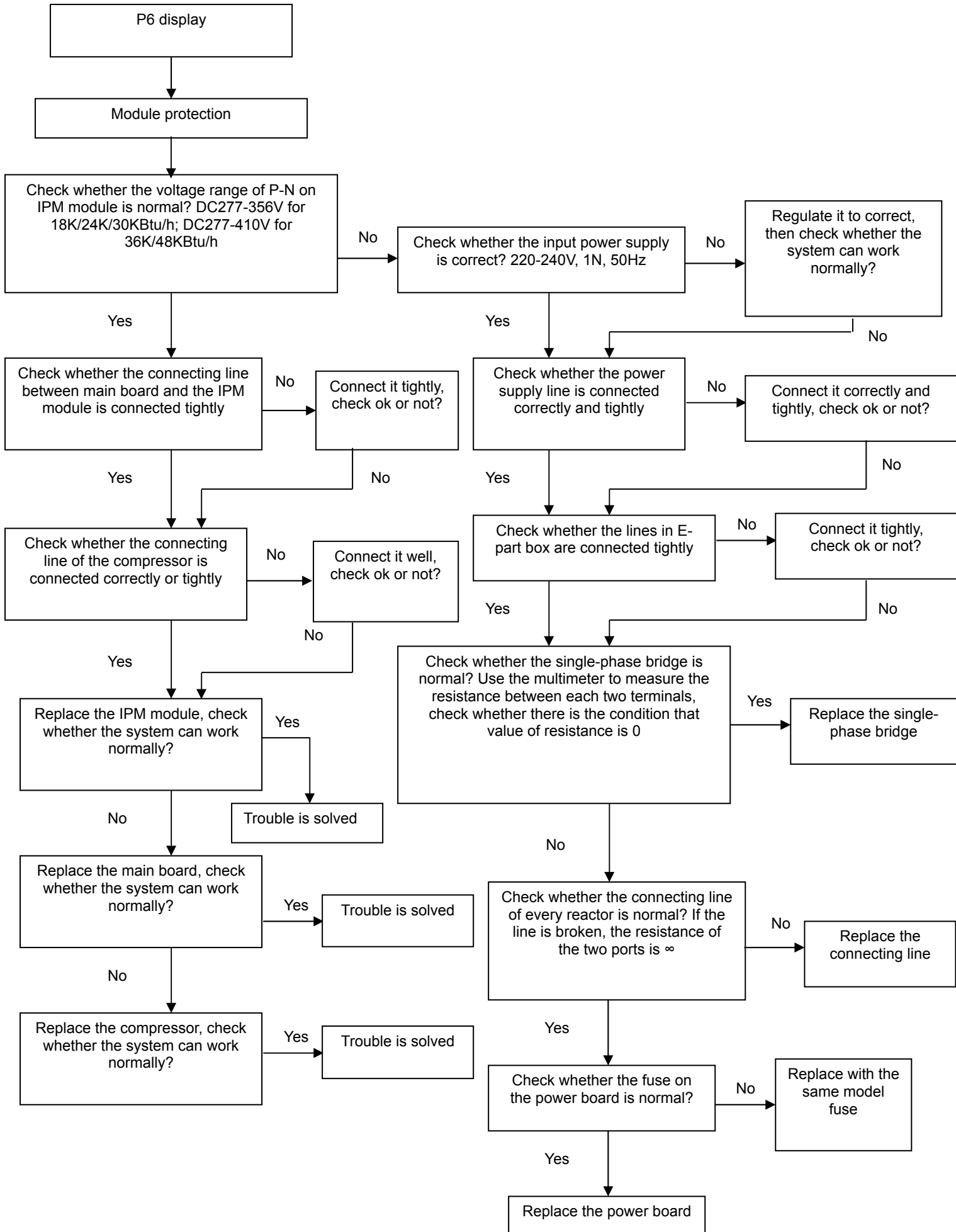

10.3.2.15. P6 malfunction (For three phases units)

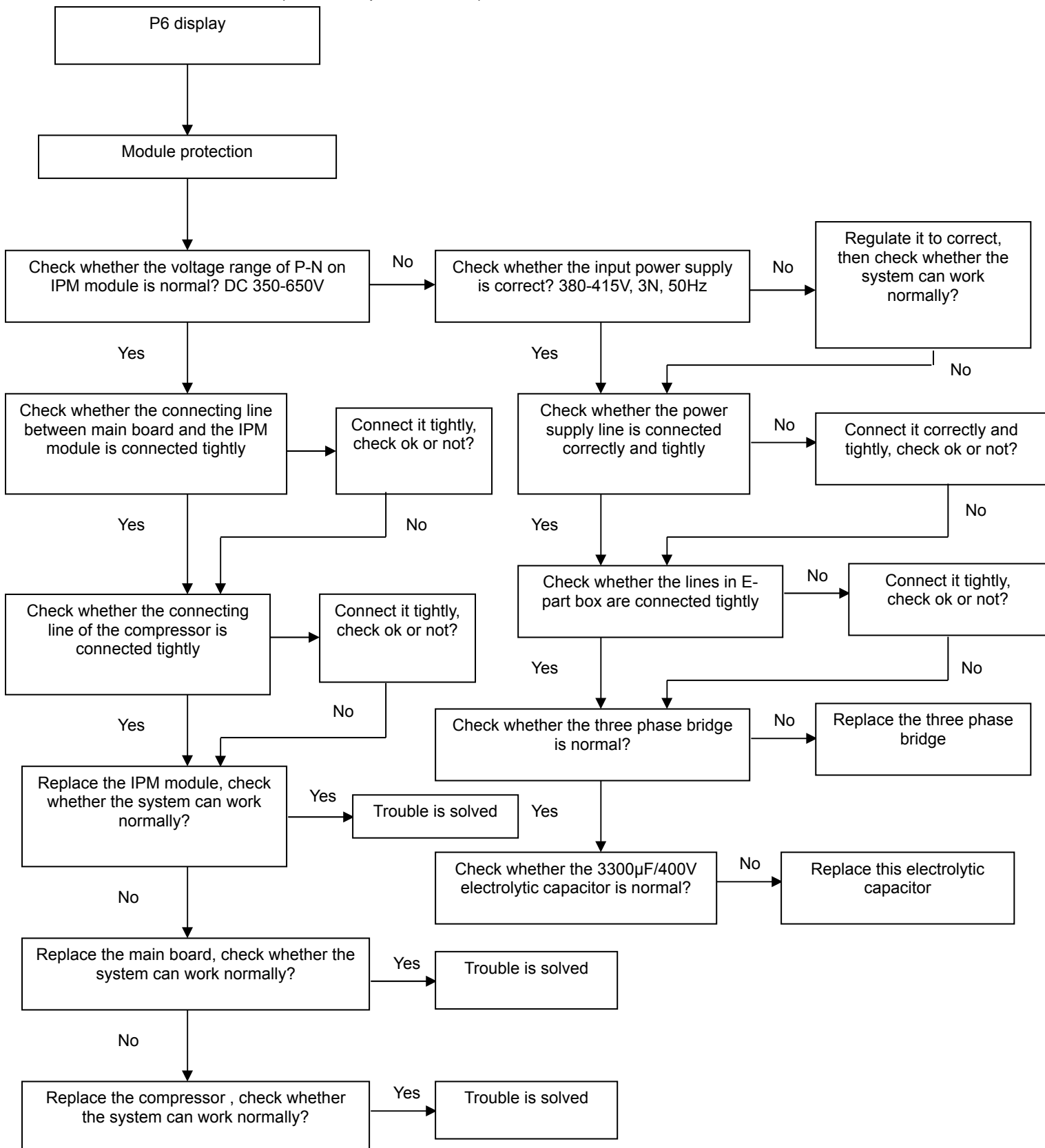

10.3.2.16. P7 malfunction

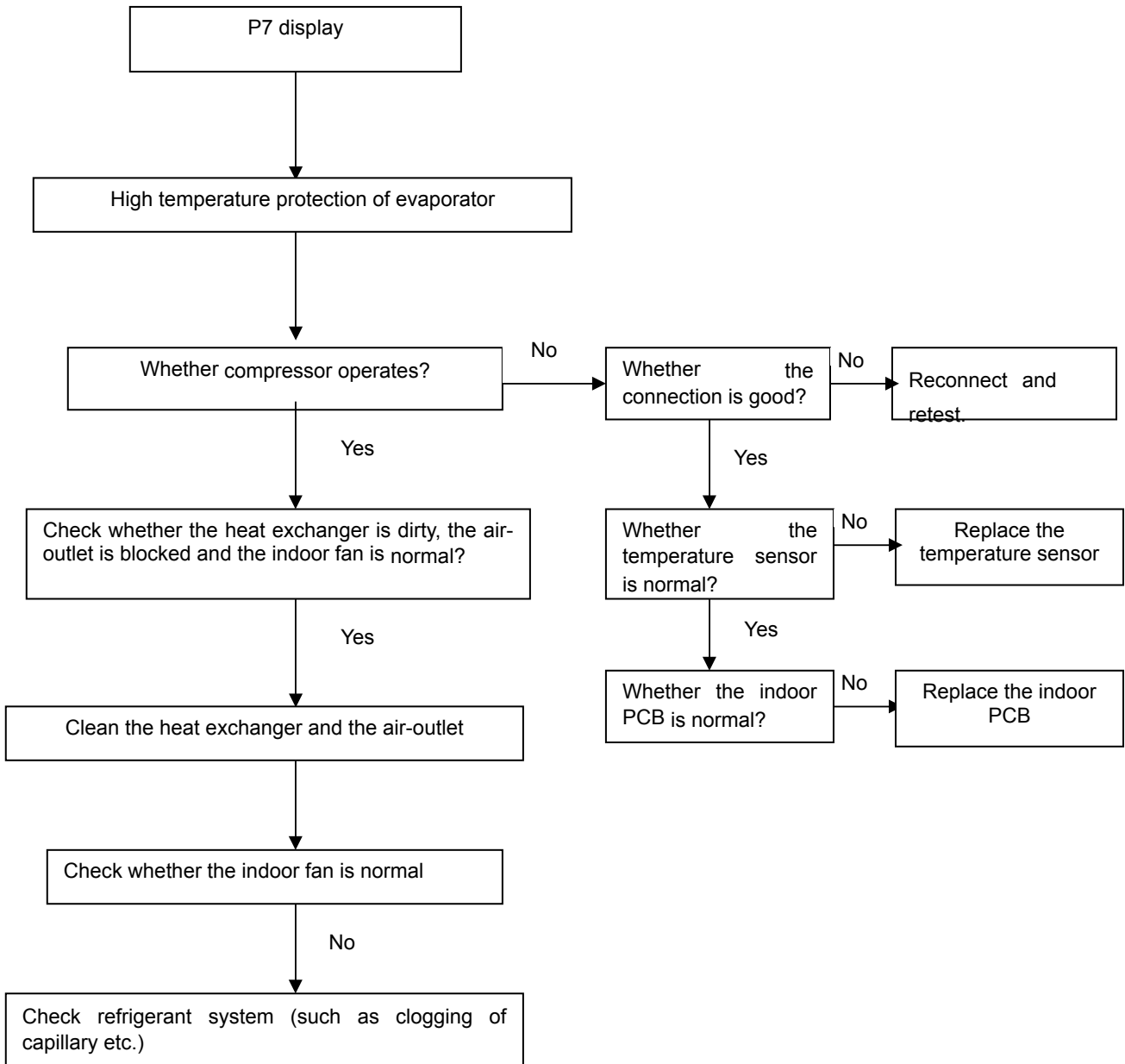

**Appendix** Indoor Temp. and Pipe Temp. Sensor Resistance Value Table (°C--K)

°C	K Ohm	°C	K Ohm	°C	K Ohm	°C	K Ohm
----	-------	----	-------	----	-------	----	-------

-20	115.266	20	12.6431	60	2.35774	100	0.62973
-19	108.146	21	12.0561	61	2.27249	101	0.61148
-18	101.517	22	11.5000	62	2.19073	102	0.59386
-17	96.3423	23	10.9731	63	2.11241	103	0.57683
-16	89.5865	24	10.4736	64	2.03732	104	0.56038
-15	84.2190	25	10.000	65	1.96532	105	0.54448
-14	79.3110	26	9.55074	66	1.89627	106	0.52912
-13	74.5360	27	9.12445	67	1.83003	107	0.51426
-12	70.1698	28	8.71983	68	1.76647	108	0.49989
-11	66.0898	29	8.33566	69	1.70547	109	0.48600
-10	62.2756	30	7.97078	70	1.64691	110	0.47256
-9	58.7079	31	7.62411	71	1.59068	111	0.45957
-8	56.3694	32	7.29464	72	1.53668	112	0.44699
-7	52.2438	33	6.98142	73	1.48481	113	0.43482
-6	49.3161	34	6.68355	74	1.43498	114	0.42304
-5	46.5725	35	6.40021	75	1.38703	115	0.41164
-4	44.0000	36	6.13059	76	1.34105	116	0.40060
-3	41.5878	37	5.87359	77	1.29078	117	0.38991
-2	39.8239	38	5.62961	78	1.25423	118	0.37956
-1	37.1988	39	5.39689	79	1.21330	119	0.36954
0	35.2024	40	5.17519	80	1.17393	120	0.35982
1	33.3269	41	4.96392	81	1.13604	121	0.35042
2	31.5635	42	4.76253	82	1.09958	122	0.3413
3	29.9058	43	4.57050	83	1.06448	123	0.33246
4	28.3459	44	4.38736	84	1.03069	124	0.32390
5	26.8778	45	4.21263	85	0.99815	125	0.31559
6	25.4954	46	4.04589	86	0.96681	126	0.30754
7	24.1932	47	3.88673	87	0.93662	127	0.29974
8	22.5662	48	3.73476	88	0.90753	128	0.29216
9	21.8094	49	3.58962	89	0.87950	129	0.28482
10	20.7184	50	3.45097	90	0.85248	130	0.27770
11	19.6891	51	3.31847	91	0.82643	131	0.27078
12	18.7177	52	3.19183	92	0.80132	132	0.26408
13	17.8005	53	3.07075	93	0.77709	133	0.25757
14	16.9341	54	2.95896	94	0.75373	134	0.25125
15	16.1156	55	2.84421	95	0.73119	135	0.24512
16	15.3418	56	2.73823	96	0.70944	136	0.23916
17	14.6181	57	2.63682	97	0.68844	137	0.23338
18	13.9180	58	2.53973	98	0.66818	138	0.22776
19	13.2631	59	2.44677	99	0.64862	139	0.22231

## **Part 4 Installation**

<a href="#"><u>1.Precaution on Installation.....</u></a>	<a href="#"><u>81</u></a>
<a href="#"><u>2.Vacuum Dry and Leakage Checking.....</u></a>	<a href="#"><u>82</u></a>
<a href="#"><u>3.Additional Refrigerant Charge .....</u></a>	<a href="#"><u>84</u></a>
<a href="#"><u>4.Water Drainage.....</u></a>	<a href="#"><u>85</u></a>
<a href="#"><u>5.Insulation Work .....</u></a>	<a href="#"><u>88</u></a>
<a href="#"><u>6.Wiring.....</u></a>	<a href="#"><u>89</u></a>
<a href="#"><u>7.Test Operation.....</u></a>	<a href="#"><u>90</u></a>

# 1. Precaution on Installation

1). Measure the necessary length of the connecting pipe, and make it by the following way.

a. Connect the indoor unit at first, then the outdoor unit.

Bend the tubing in proper way. Do not harm them.

*Specially Notice the pipe length/height/dimension of each capacity.*

## Maximum pipe length

Model	Max. Length	Max. Elevation
12,000Btu/h	10m	5m
18,000Btu/h ~24,000Btu/h	25m	12m
30,000Btu/h	25m	15m
36,000Btu/h	30m	20m
48,000Btu/h ~60,000Btu/h	50m	25m

## Piping sizes

Model	Liquid(mm)	Gas(mm)
12,000Btu/h~18,000Btu/h	6.4	12.7
24,000Btu/h~60,000Btu/h	9.5	15.9

## CAUTIONS

- Daub the surfaces of the flare pipe and the joint nuts with frozen oil, and wrench it for 3~4 rounds
- With hands before fasten the flare nuts.
- Be sure to use two wrenches simultaneously when you connect or disconnect the pipes.

Pipe gauge	Tightening torque	Flare dimension A		Flare shape
		Min (mm)	Max	
Φ6.4	14.2~17.2N.m (144~176 kgf.cm)	8.3	8.7	
Φ9.5	32.7~39.9N.m (333~407kgf.cm)	12.0	12.4	
Φ12.7	49.5~60.3N.m (504~616kgf.cm)	15.4	15.8	
Φ15.9	61.8~75.4N.m (630~770 kgf.cm)	18.6	19.1	
Φ19	97.2~118.6N.m (990~1210kgf.cm)	22.9	23.3	

b. The stop valve of the outdoor unit should be closed absolutely (as original state). Every time you connect it, first loosen the nuts at the part of stop valve, then connect the flare pipe immediately (in 5 minutes). If the nuts have been loosened for a long time, dusts and other impurities may enter the pipe system and may cause malfunction later. So please expel the air out of the pipe with refrigerant before connection.

c. Expel the air after connecting the refrigerant pipe with the indoor unit and the outdoor unit. Then fasten the nuts at the repair-points.

2) Locate The Pipe

a. Drill a hole in the wall (suitable just for the size of the wall conduit), then set on the fittings such as the wall conduit and its cover.

b. Bind the connecting pipe and the cables together tightly with binding tapes. Do not let air in, which will cause water leakage by condensation.

c. Pass the bound connecting pipe through the wall conduit from outside. Be careful of the pipe allocation to do no damage to the tubing.

3) Connect the pipes.

4) Then, open the stem of stop valves of the outdoor unit to make the refrigerant pipe connecting the indoor unit with the outdoor unit in fluent flow.

5) Be sure of no leakage by checking it with leak detector or soap water.

6) Cover the joint of the connecting pipe to the indoor unit with the soundproof / insulating sheath (fittings), and bind it well with the tapes to prevent leakage.

## 2. Vacuum Dry and Leakage Checking

- 1) Vacuum Dry: use vacuum pump to change the moisture (liquid) into steam (gas) in the pipe and discharge it out of the pipe to make the pipe dry. Under one atmospheric pressure, the boiling point of water (steam temperature) is 100°C. Use vacuum pump to make the pressure in the pipe near vacuum state, the boiling point of water falls relatively. When it falls under outdoor temperature, the moisture in the pipe will be vaporized.

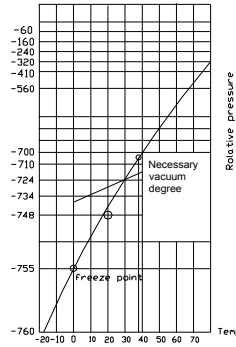

### 2) Vacuum dry procedure

There are two methods of vacuum dry due to different construction environment: common vacuum dry, special vacuum dry.

#### ①. Common vacuum dry procedure

- Vacuum dry (for the first time)---connect the all-purpose detector to the inlet of liquid pipe and gas pipe, and run the vacuum pump more than two hours (the vacuum pump should be below -755mmHg)
- If the pump can't achieve below -755mmHg after pumping 2 hours, moisture or leakage point will still exist in the pipe. At this time, it should be pumped 1 hour more.
- If the pump can't achieve -755mmHg after pumping 3 hours, please check if there are some leakage points.
- Vacuum placement test: place 1 hour when it achieves -755mmHg, pass if the vacuum watch shows no rising. If it rises, it shows there's moisture or leakage point.
- Vacuuming from liquid pipe and gas pipe at the same time.
- Sketch map of common vacuum dry procedure.

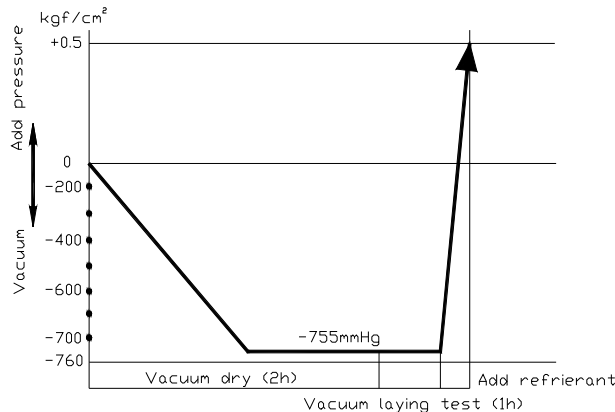

②. Special vacuum dry procedure

- This vacuum dry method is used in the following conditions:  
There's moisture when flushing the refrigerant pipe.  
Rainwater may enter into the pipe.

- Vacuum dry for the first time ..... 2h pumping

③. Vacuum destroy for the second time ..... Fill nitrogen to 0.5Kgf/cm<sup>2</sup>

Because nitrogen is for drying gas, it has vacuum drying effect during vacuum destroy. But if the moisture is too much, this method can't dry thoroughly. So, please pay more attention to prevent water entering and forming condensation water.

- ④. Vacuum dry for the second time ..... 1h pumping

Determinant: Pass if achieving below -755mmHg. If -755mmHg can't be achieved in 2h, repeat procedure ③ and ④.

- ⑤. Vacuum placing test ..... 1h
- ⑥. Sketch map of special vacuum dry procedure

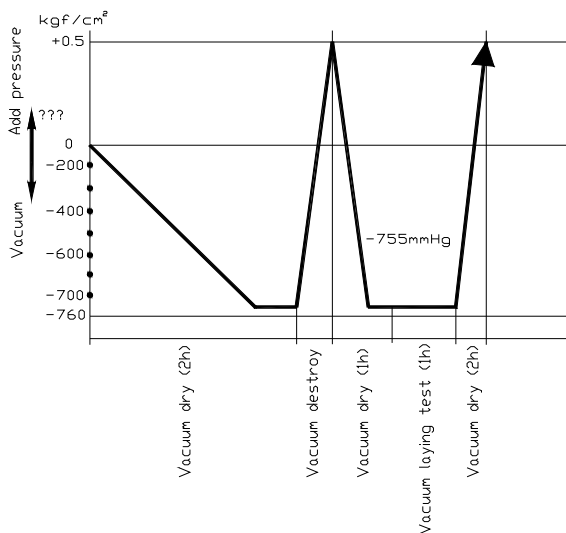



### 3. Additional Refrigerant Charge

#### Caution

- Refrigerant cannot be charged until field wiring has been completed.
- Refrigerant may only be charged after performing the leak test and the vacuum pumping.
- When charging a system, care shall be taken that its maximum permissible charge is never exceeded, in view of the danger of liquid hammer.
- Charging with an unsuitable substance may cause explosions and accidents, so always ensure that the appropriate refrigerant is charged.
- Refrigerant containers shall be opened slowly.
- Always use protective gloves and protect your eyes when charging refrigerant.

The outdoor unit is factory charged with refrigerant. Calculate the added refrigerant according to the diameter and the length of the liquid side pipe of the outdoor unit/indoor unit.

R(g) D(mm)	φ6.4	Φ9.5	Φ12.7
L(m)			
Less than 5m (One-way)	—	—	—
Added Refrigerant When Over 5m(One-way)	11g/m×(L-5)	30g/m×(L-5)	60g/m×(L-5)

#### Remark:

R (g): Additional refrigerant to be charged

L (m): The length of the refrigerant pipe (one-way)

D (mm): Liquid side piping diameter

## 4. Water Drainage

### 4.1 Gradient and Supporting

- 1). Keep the drainpipe sloping downwards at a gradient of at least 1/50. Keep the drainpipe as short as possible and eliminate the air bubble.
- 2). The horizontal drainpipe should be short. When the pipe is too long, a prop stand must be installed to keep the gradient of 1/50 and prevent bending. Refer to the following table for the specification of the prop stand.

	Diameter	Distance between the prop stands
Hard PVC pipe	25~40mm	1.5~2m

#### 3). Precautions

- ① The diameter of drainpipe should meet the drainage requirement at least.
- ② the drainpipe should be heat-insulated to prevent atomization.
- ③ Drainpipe should be installed before installing indoor unit. After powering on, there is some water in water-receiver plate. Please check if the drain pump can operate correctly.
- ④ All connection should be firm.
- ⑤ Wipe color on PVC pipe to note connection.
- ⑥ Climbing, horizontal and bending conditions are prohibited.
- ⑦ The dimension of drainpipe can't less than the connecting dimension of indoor drainpipe.
- ⑧ Heat-insulation should be done well to prevent condensation.
- ⑨ Indoor units with different drainage type can't share one convergent drainpipe.

### 4.2 Drainpipe Trap

- 1). If the pressure at the connection of the drainpipe is negative, it needs to design drainpipe trap.
- 2). Every indoor unit needs one drainpipe trap.
- 3). A plug should be designed to do cleaning.

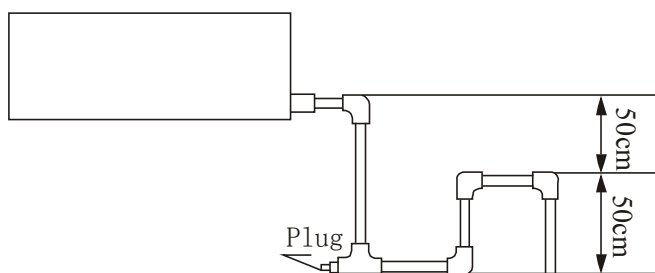

### 4.3 Upwards drainage (drain pump)

For Four-way cassette(compact)

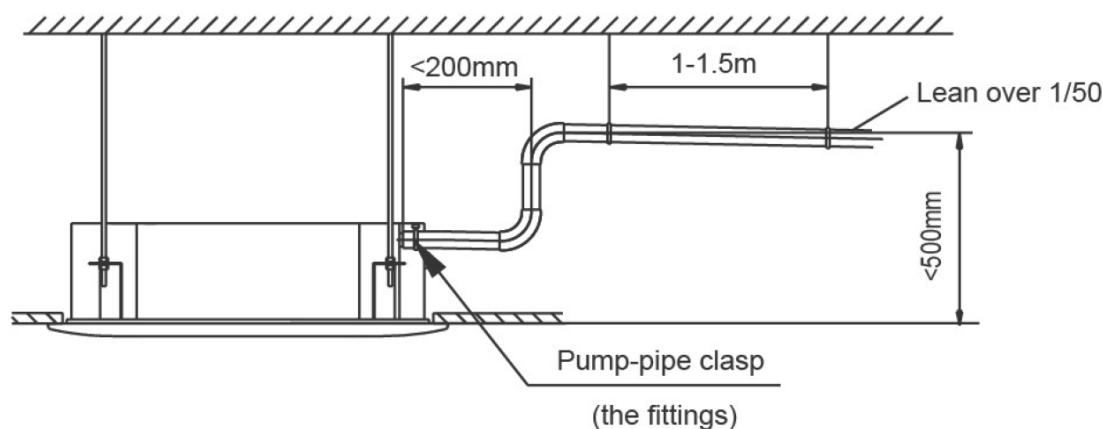

**For Four-way cassette**

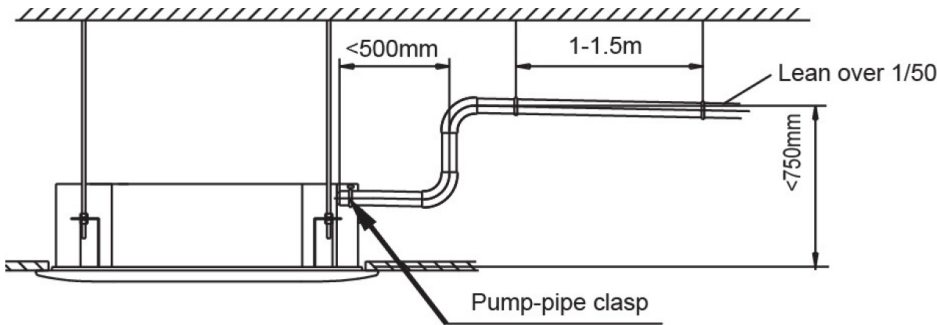

**4.4 Convergent drainage**

- 1). The number of indoor units should be as small as possible to prevent the traverse main pipe overlong.
- 2). Indoor unit with drain pump and indoor unit without drain pump should be in different drainage system.



- 3). Selecting the diameter

Number of connecting indoor units → Calculate drainage volume → Select the diameter

Calculate allowed volume = Total cooling capacity of indoor units (HP) × 2 (l/ hr)

	Allowed volume(lean 1/50) (l/ hr)	I.D. (mm)	Thick
Hard PVC	~≤14	∅ 25	3.0
Hard PVC	14 < s ≤ 88	∅ 30	3.5
Hard PVC	88 < s ≤ 334	∅ 40	4.0
Hard PVC	175 < s ≤ 334	∅ 50	4.5
Hard PVC	334 < s	∅ 80	6.0

**4.5 Drainage test**

- 1). Drainage without drain pump

After finishing drainpipe installation, pour some water into the water receiver plate to check if the water flows smoothly.

- 2). Drainage with drain pump

- ① Poke the Water Level Switch, remove the cover, use water pipe to pour 2000ml water into the water receipt plate through the water inlet.

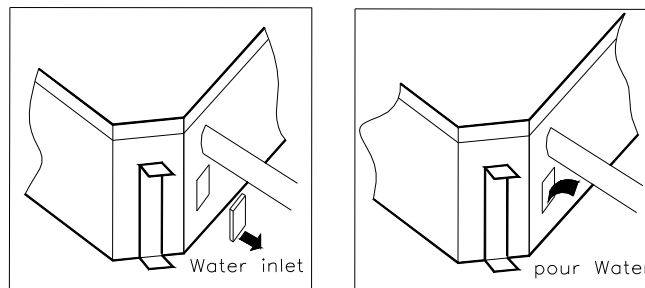

- ② Turn on the power to Cooling operation. Check the pump's operation and switch on the Water Level Switch. Check the pump's sound and look into the transparent hard pipe in the outlet at the same time to check if the water can discharge normally.

③ Stop the air conditioner running, turn off the power, and put back the cover.

- Stop the air conditioner. After 3 minutes, check if it has abnormality. If the collocation of drainpipes is illogical, the water will flow back overfull, which will cause the alarm lamp flashes, even overflow from the water receipt plate.
- Keep on pouring water until it gives an alarm signal for high water level, check if the pump drains water at once. If the water level can't fall below the alarmed water level after 3 minutes, the air conditioner will stop. Turn off the power and drain the remained water, and then turn on the air conditioner.

**Note:** the drain stuff in the main water receipt plate is for maintenance. Stuff up the drain stuff to prevent water leakage.

## 5. Insulation Work

### 5.1 Insulation material and thickness

1). Insulation material

Insulation material should adopt the material which is able to endure the pipe's temperature: no less than 70°C in the high-pressure side, no less than 120°C in the low-pressure side(For the cooling type machine, no requirements at the low-pressure side.)

Example: Heat pump type----Heat-resistant Polyethylene foam (withstand above 120°C)

Cooling only type---- Polyethylene foam (withstand above 100°C)

2). Thickness choice for insulation material

Insulation material thickness is as follows:

	Pipe diameter (mm)	Adiabatic material thickness
Refrigerant pipe	Φ6.4—Φ25.4	10mm
	Φ28.6—Φ38.1	15mm
Drainage pipe	Inner diameterΦ20—Φ32	6mm

### 5.2 Refrigerant pipe insulation

1). Work Procedure

- ① Before laying the pipes, the non-jointing parts and non-connection parts should be heat insulated.
- ② When the gas proof test is eligible, the jointing area, expanding area and the flange area should be heat insulated

2). Insulation for non-jointing parts and non-connection parts

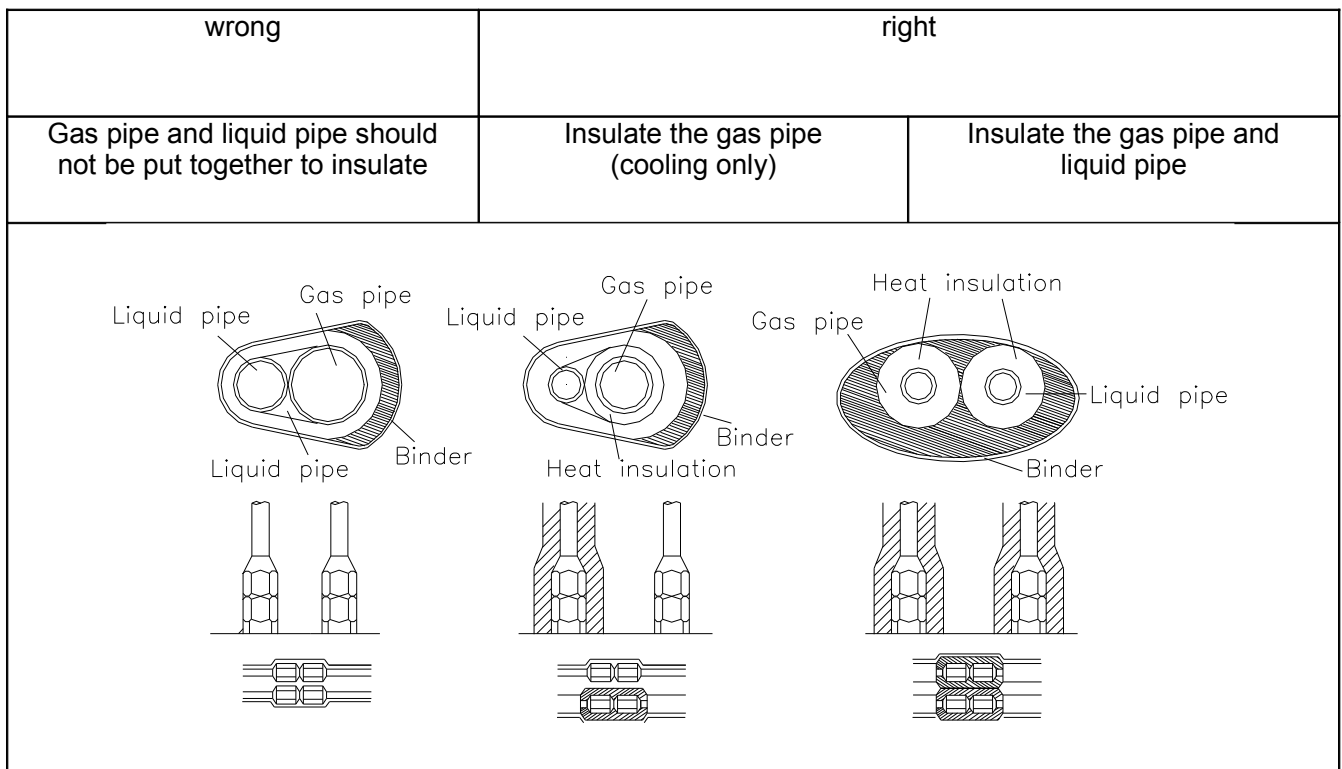

For construction convenience, before laying pipes, use insulation material to insulate the pipes to be deal with, at the same time, at two ends of the pipe, remain some length not to be insulated, in order to be welded and check the leakage after laying the pipes.

3). Insulate for the jointing area, expanding area and the flange area

① Insulate for the jointing area, expanding area and the flange area should be done after checking leakage of the pipes

② Make sure there's no clearance in the joining part of the accessorial insulation material and local preparative insulation material.

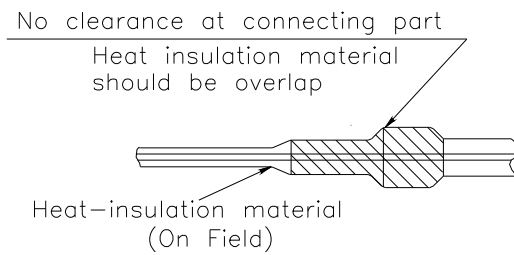

### 5.3 Drainage pipe insulation

1) The connection part should be insulated, or else water will be condensing at the non-insulation part.

### 5.4 Note

1) The jointing area, expanding area and the flange area should be heat insulated after passing the pressure test

2) The gas and liquid pipe should be heat insulated individually, the connecting part should be heat insulated individually.

3) Use the attached heat-insulation material to insulate the pipe connections (pipes' tie-in ,expand nut ) of the indoor unit.

## 6. Wiring

Please refer to the Wiring Diagram.

## 7. Test Operation

**(1) The test operation must be carried out after the entire installation has been completed.**

**(2) Please confirm the following points before the test operation.**

- The indoor unit and outdoor unit are installed properly.
- Tubing and wiring are correctly completed.
- The refrigerant pipe system is leakage-checked.
- The drainage is unimpeded.
- The ground wiring is connected correctly.
- The length of the tubing and the added stow capacity of the refrigerant have been recorded.
- The power voltage fits the rated voltage of the air conditioner.
- There is no obstacle at the outlet and inlet of the outdoor and indoor units.
- The gas-side and liquid-side stop valves are both opened.
- The air conditioner is pre-heated by turning on the power.

**(3) According to the user's requirement, install the remote controller when the remote controller's signal can reach the indoor unit smoothly.**

**(4) Test operation**

Set the air conditioner under the mode of "COOLING" with the remote controller, and check the following points.

### Indoor unit

- Whether the switch on the remote controller works well.
- Whether the buttons on the remote controller works well.
- Whether the air flow louver moves normally.
- Whether the room temperature is adjusted well.
- Whether the indicator lights normally.
- Whether the temporary buttons works well.
- Whether the drainage is normal.
- Whether there is vibration or abnormal noise during operation.

### Outdoor unit

- Whether there is vibration or abnormal noise during operation.
- Whether the generated wind, noise, or condensed of by the air conditioner have influenced your neighborhood.
- Whether any of the refrigerant is leaked.

**Part 5**  
**Control**

[1.Controller.....92](#)



# 1. Controller

## 1.3 KJR-10B

### Name and functions of buttons on the wire controller

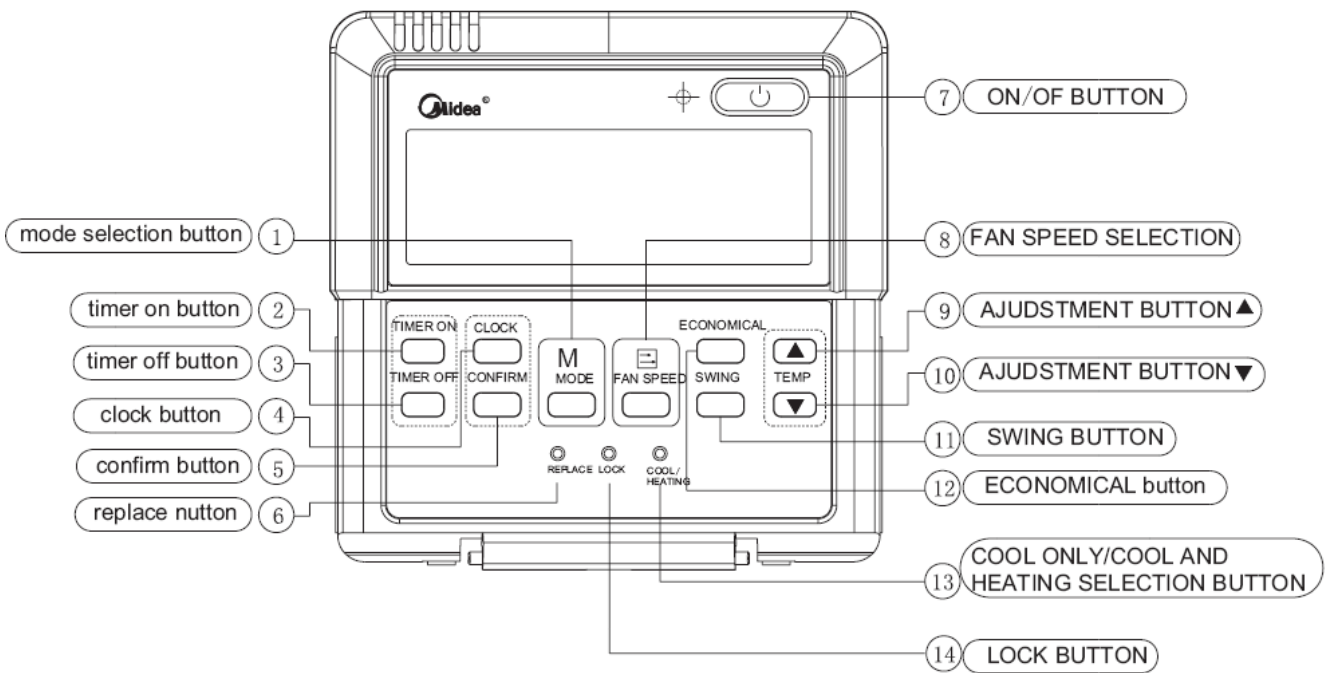

**1 mode selection button:**

It is used to select mode, push the button one time, then the operation modes will change In turn as follows:

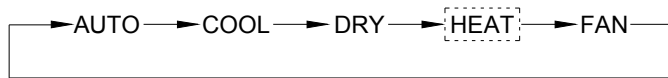

Remark: no heating mode if wire controller is set as the cool only.

**2 Timer on button:**

Push the button to set TIMER ON, each time you push the button the time moves forward by 0.5 hours. When the set time is over 10 hours, each time you push the button the time moves forward by 1 hour. If want to cancel the TIMER ON, then adjust the time of TIMER ON as 0.0

**3 Timer off button:**

Push the button to set TIMER OFF, each time you push the button the time moves forward by 0.5 hours. When the set time is over 10 hours, each time you push the button the time moves forward by 1 hour. If want to cancel the TIMER OFF, then adjust the time of TIMER OFF as 0.0

**4 CLOCK button:**

Normally display the clock set currently (display 12:00 for the first electrifying or resetting). When push the button for 4 seconds, the hour part on the clock display flashes every 0.5 seconds, then push button and to adjust hour; push the button CLOCK again, the minute part flashes every 0.5 seconds, then push and button to adjust minute. When set clock or alter clock setting, must push the confirm button to complete the setting

### Name and function of LCD on the wire controller

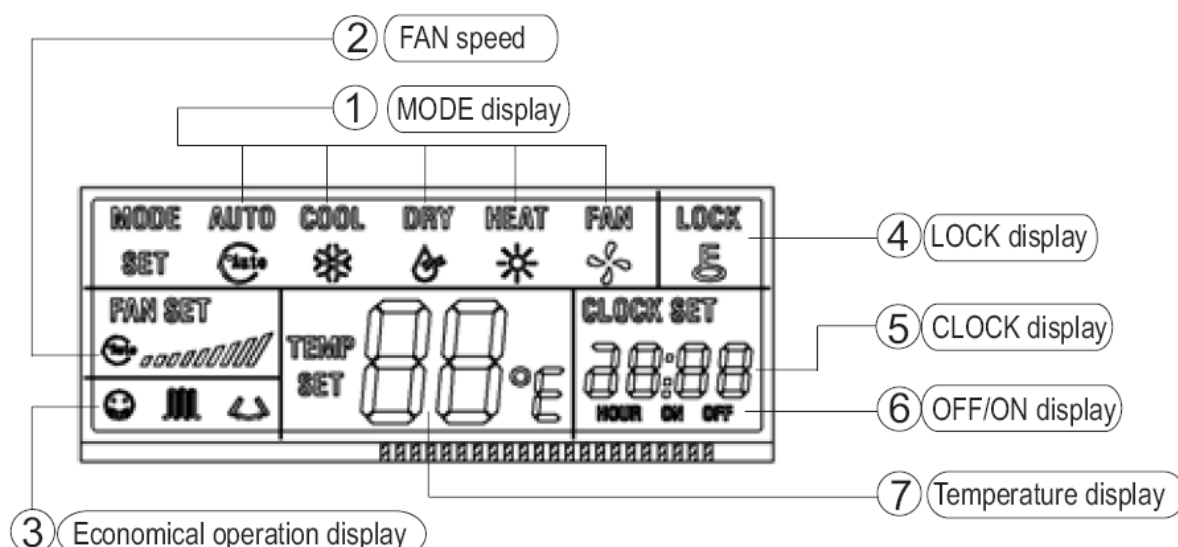

#### 1 Mode select button (MODE):

Press MODE button to select "COOL", "DRY", "HEAT", or "FAN ONLY" mode. (HEAT is invalid for COOL ONLY wire controller.)

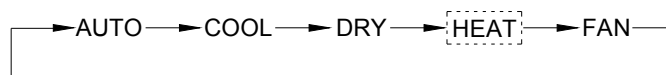

#### 2 Fan speed button (FAN SPEED)

Press FAN SPEED to select fan speed from "AUTO", "LOW", "MED", and "HIGH". NOTE: some air conditioners have no MED fan speed, and then the MED is regarded as HIGH.

#### 3 Economical operation displays:

Press ECONOMICAL to display economical operation, if press ECONOMICAL again then the display disappears

#### 4 Lock display

Press LOCK to display the icon of LOCK. Press the button again then the icon of LOCK disappears. In the mode of LOCK, all the buttons are invalid except for LOCK button.

#### 5 CLOCK display.

Usually display the clock set currently. Press the button CLOCK for 4 seconds, the HOUR part will flash, press button ▲ and ▼ to adjust HOUR. Press the button CLOCK again, the minute part flash, press button ▲ or ▼ to adjust MINUTE. After clock set or clock operation, it must press CONFIRM to complete the set.

6 TIMER ON/OFF display:

Display ON at the state of TIMER ON adjustment or after only set the TIMER ON; Display OFF at the state of TIMER OFF adjustment or after only set the TIMER OFF; Display ON/OFF if simultaneously set the mode of TIMER ON and TIMER OFF.

7 Temperature display area:

Usually display the set temperature. Press the buttons of and to set temperature, at the mode of FAN, there is no figure display in the area.

**Installation**

Wiring Principle Sketch:

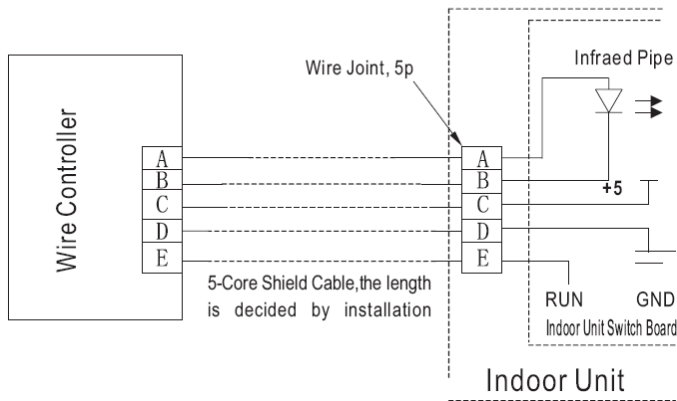

**Installation Notice:**

When the air conditioner needs the constant frequency wire Controller, be sure adding a Wire Joint with 5 terminal named A, B, C, D, E in indoor unit, and fixing a infrared emitter whose anode and cathode connecting with A and B near the receiver in the Indoor Unit Switch Board, then connecting the terminal +5v, GND, Run in the Switch Board to C,D,E respectively.

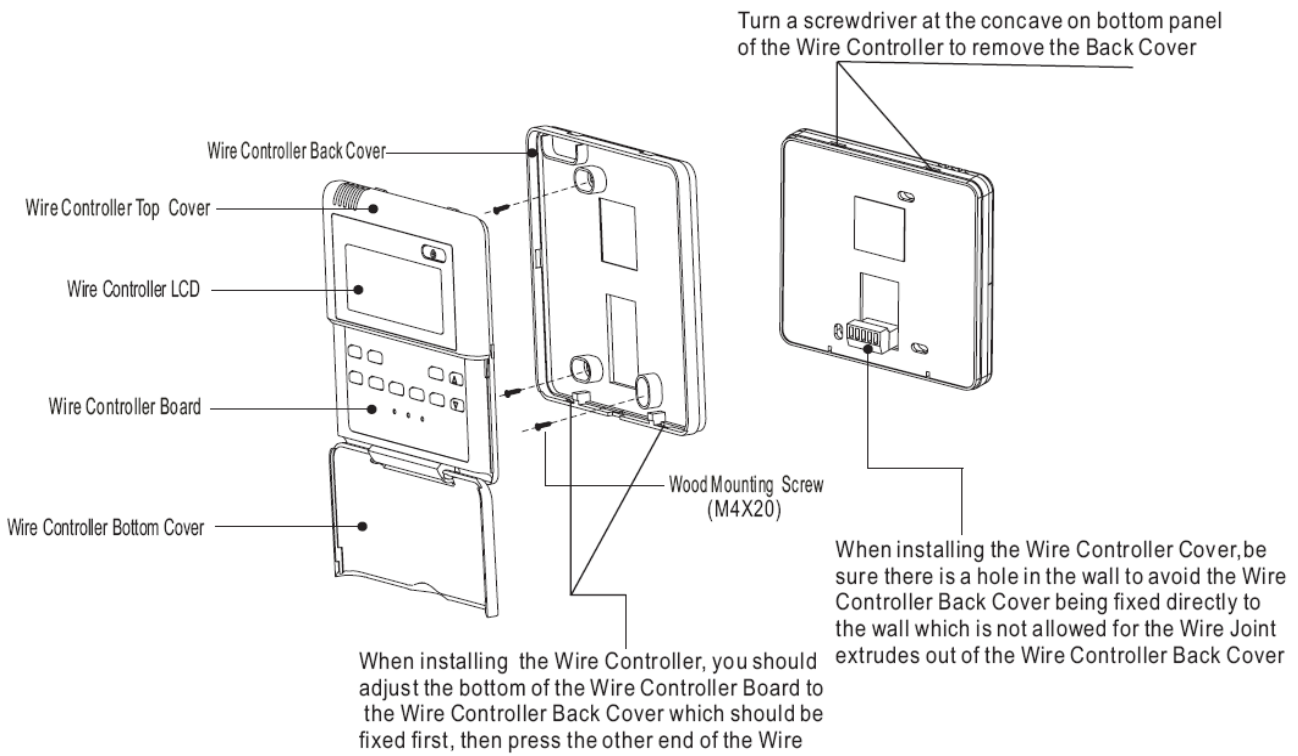
**NOTE**

Never turn screws too tightly, or else the cover would be dented or the Liquid Crystal breaks.

Please leave enough long cable for maintenance of the Wire Controller Board.