

Part 3 Installation

1.	Precautions	51
2.	Accessories	52
3.	Outdoor Unit Intstallation	52
4.	Piping Installation.....	54
5.	Electric System.....	59
6.	Outdoor Unit Wiring	67
7.	Test Running	71
8.	Precautions on Refrigerant Leakage.....	72

1. Precautions

- Ensure that all Local, National and International regulations are satisfied.
- Read this "PRECAUTIONS" carefully before Installation.
- The precautions described below include the important Items regarding safety.
- Observe them without fail.
- After the installation work, perform a trial operation to check for any problem.
- Follow the Owner's Manual to explain how to use and maintain the unit to the customer.
- Turn off the main power supply switch (or breaker) before maintenance the unit.
- Ask the customer that the Installation Manual and the Owner's manual should be kept together.

Caution 1:

The characteristics of R410A refrigerant are: Hydrophilic, oxidizing membrane or oil, and its pressure is approx.1.6 times higher than that of refrigerant R22. Accompanied with the new refrigerant, refrigerating oil has also been changed, Therefore, during installation work, be sure that water, dust, former refrigerant, or refrigerating oil does not enter the refrigerating cycle.

To prevent charging an incorrect refrigerant and refrigerating oil, the sizes of connecting sections of charging port of the main unit and installation tools are charged from those for the conventional refrigerant.

Accordingly the exclusive tools are required for the new refrigerant (R410A).

For connecting pipes, use new and clean pipes designed for R410A, and please care so that water or dust does not enter. Moreover, do not use the existing piping because there are problems with pressure-resistance force and impurity in it.

Caution 2:

This unit must be connected to the main power supply by means of a switch with a contact separation of at least 3 mm.

The installation fuse must be used for the power supply line of this conditioner.

Caution 3:

Ask an authorized dealer or qualified installation professional to install/maintain the air conditioner. Inappropriate installation may result in water leakage, electric shock or fire.

Turn off the main power supply switch or breaker before attempting any electrical work. Make sure all power switches are off. Failure to do so may cause electric shock.

Connect the connecting cable correctly. If the connecting cable is connected in a wrong way, electric parts may be damaged. When moving the air conditioner for the installation into another place, be very careful not to enter any gaseous matter other than the specified refrigerant into the refrigeration cycle. If air or any other has is mixed in refrigerant, the gas pressure in the refrigeration cycle becomes abnormally high and it may resultantly causes pipe burst and injuries on persons.

Do not modify this unit by removing any of the safety guards or by by-passing any of the safety inter lock switches.

Exposure of unit to water or other moisture before installation may cause a short circuit of electrical parts.

Do not store it in a wet basement or expose to rain or water. After unpacking the unit, examine it carefully if there are possible damage.

Do not install in a place that might increase the vibration of the unit. To avoid personal injury (with sharp edges) be careful when handling parts.





Perform installation work properly according to the Installation Manual. Inappropriate installation may result in water leakage, electric shock or fire. When the air conditioner is installed in a small room, provide appropriate measures to ensure that the concentration of refrigerant leakage occur in the room does not exceed the critical level. If refrigerant gas has leaked during the installation work, ventilate the room immediately. If the leaked refrigerant gas comes in contact with fire, noxious gas may generate. After the installation work, confirm that refrigerant gas doer not leak. If refrigerant gas leaks into the room and flows near a fire source, such as a cooking range, noxious gas might generate.

Install the air conditioner securely in a location where the base can sustain the weight adequately. Perform the specified installation work to guard against an earthquake. If the air conditioner is not installed appropriately, accidents may occur due to the falling unit.

Electrical work must be performed by a qualified electrician in accordance with the Installation Manual. Make sure the air conditioner uses an exclusive power supply. An insufficient power supply capacity or inappropriate installation may cause fire. Use the specified cables for wiring connect the terminals securely fix. To prevent external forces applied to the terminals from affecting the terminals. Be sure to provide grounding. Do not connect ground wires to gas pipes, water pipes, lightning rods or ground wires for telephone cables. Conform to the regulations of the local electric company when wiring the power supply. Inappropriate grounding may cause electric shock Do not install the air conditioner in a location subject to a risk of exposure to a combustible gas. If a combustible gas leaks, and stays around the unit, a fire may occur.

2. Accessories

Please check whether the following fittings are of full scope. If there are some spare fittings, please keep them carefully.

INSTALLATION FITTINGS	NAME	SHAPE	QUANTITY
	1. Outdoor unit installation manual		1
	2. Outdoor unit owner's manual		1
	3. Indoor unit owner's manual		1
	4. Outflow connecting tube		1

3. Outdoor unit installation
3.1 Installation space selection

- Install the outdoor unit at a place where discharge air is not blocked. When an outdoor unit is installed in a place that is always exposed
- To a strong wind like a coast or on the high store of a building, secure a normal fan operation by using a duct or a wind shield.
- When installing the outdoor unit in a place that is constantly exposed to a strong wind such as the upper stairs or rooftop of a building, apply the windproof measures referring to the following examples.
- Install the unit so that its discharge port faces to the wall of the building. Keep a distance 2000mm or more between the unit and the wall surface.
- Supposing the wind direction during the operation season of the discharge port is set at right angle to the wind direction.

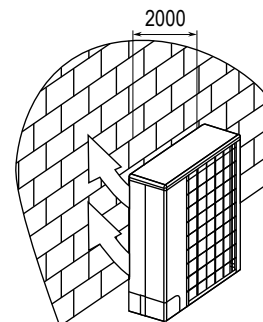
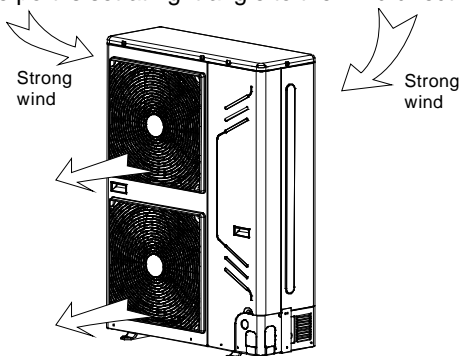

- Do not install the unit in a place full of machine oil.
- Do not install the unit in a place full of sulphuric gas.
- Do not install the unit in a place where high-frequency radio waves are likely to be.

3.2 Installation space (units: mm)

- Since the gravity center of the unit is not at its physical center, so please be careful when lifting it with a sling.
- Never hold the inlet of the outdoor unit to prevent it from deforming.
- Do not touch the fan with hands or other objects.
- Do not lean it more than 45°, and do not lay it sidelong.
- Make concrete foundation according to the specifications of the outdoor units.
- Fasten the feet of this unit with bolts firmly to prevent it from collapsing in case of earthquake or strong wind.

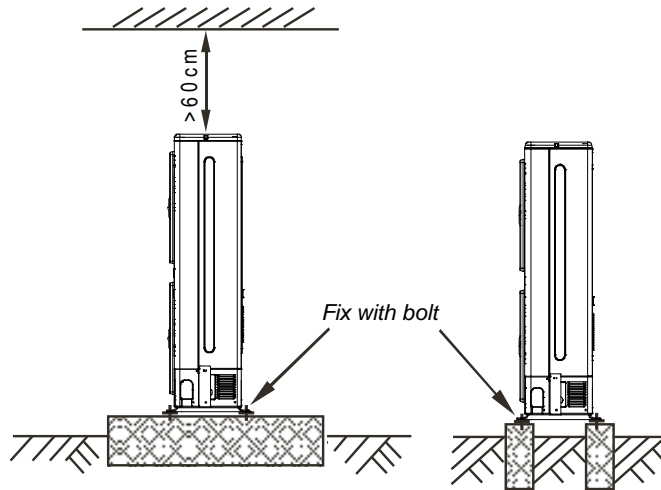

Single unit installation

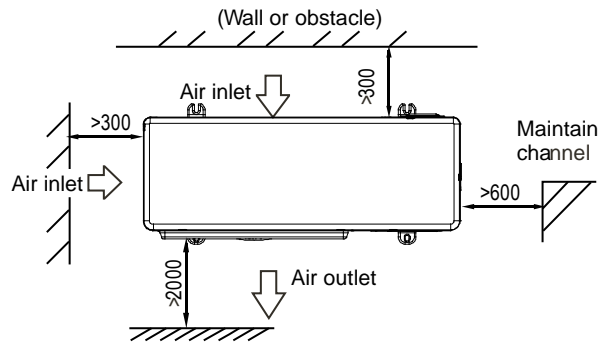

Parallel connect two units or above

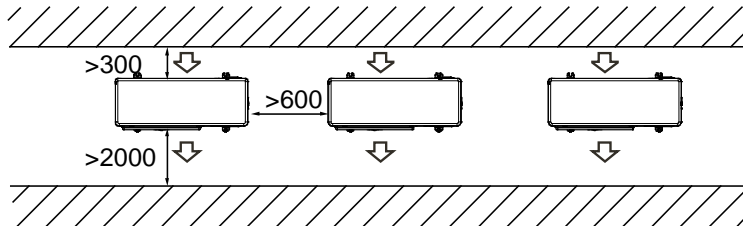

Parallel connect the front with rear sides

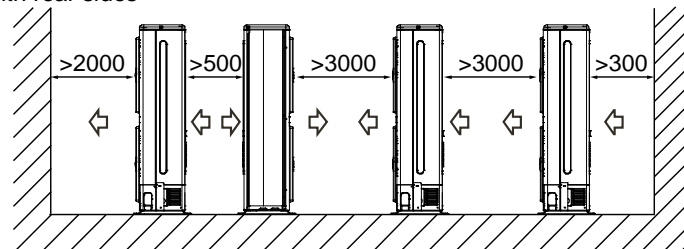

All the pictures in this manual are for explanation purpose only. They may be slightly different from the air conditioner you purchased (depend on model).The actual shape shall prevail.

3.3 Water Outlet

Four condensed water outlets on the chassis for selection display as the follow figure:

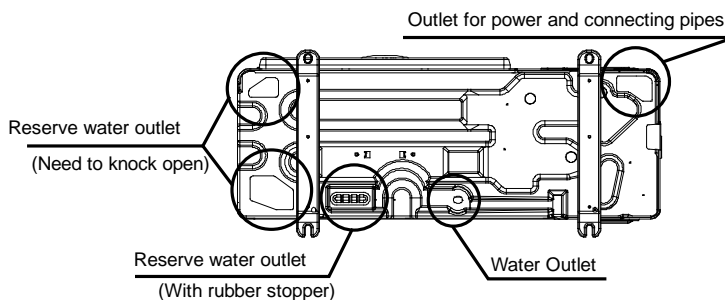

While installing the outdoor unit, pay attention to the installation place and the drainage pattern; if it's installed at the alpine zone, the frozen condensed water will block up the water outlet, please pull out the rubber stopper of the reserve water outlet. If that still fails to satisfy for the water draining, please knock open the other two water outlets, and keep the water can drain in time. Pay attention to the knock the reserve water outlet from outside to inside, and it will be beyond repair after knocking open, please pay attention to the installation place, lest cause the inconvenience. Please do the moth proofing for the knocked out hole, to avoid the pest processing into and destroy the components.

4. Piping installation

4.1 Piping connection

Offering four directions to connect pipes and wirings for meet a variety of installation request.

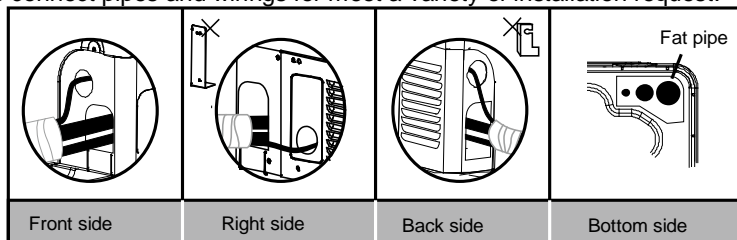

Right side pipe connection: please remove the L-shape metal plate, otherwise cannot wiring.

Back side pipe connection: Please wipe off the piping support rubber blanket beside the inner outlet pipe cover of the machine while back side getting out pipes.

Bottom side pipe connection: the knock out should from inside to outside, and then piping and wiring through this.

Pay attention to the piping the fat connecting pipe should out from the largest hole, otherwise the pipes will be rubbed. Please do the moth proofing for the knocked out hole, to avoid the pest processing into and destroy the components.

4.2 Allowable length and level difference of refrigerant pipe

		Permitted value	Piping	
Pipe Length	Total Pipe Length(Actual)	≤100m	L1+L2+L3+L4+L5+a+b+c+d+e+f	
	Maximum Piping(L)	Actual Length	≤60	L1+L2+L3+L4+L5+f(The first connecting method) or L1+L3+L5+f(The second connecting method)
		Equivalent Length	≤70m	
	Pipe Length (from the first branch to the furthest IDU)	≤20m	L2+L3+L4+L5+f(The first connecting method) or L3+L5+f(The second connecting method)	
Pipe Length(IDU to the nearest branch)	≤15m	a,b,c,d,e		
Level difference	Level difference between IDU~ODU	Outdoor Unit up	≤30m	----
		Indoor Unit Down	≤20m	----
	Level difference between IDU~IDU	≤8m	----	

Note: When the total equivalent piping length of liquid + gas side is ≥90m, it must increase the size of air side main pipe. Besides, according to the distance of refrigerant pipe and the over matched state of indoor unit, when the capacity is decreasing it still can increase the gas side main pipe size.

The first connecting method

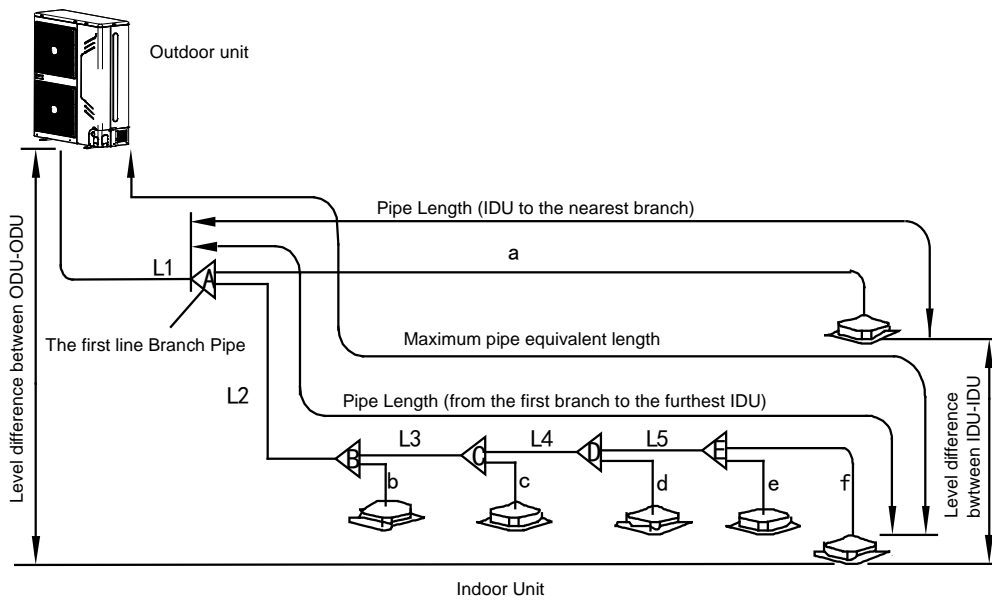

The second connecting method

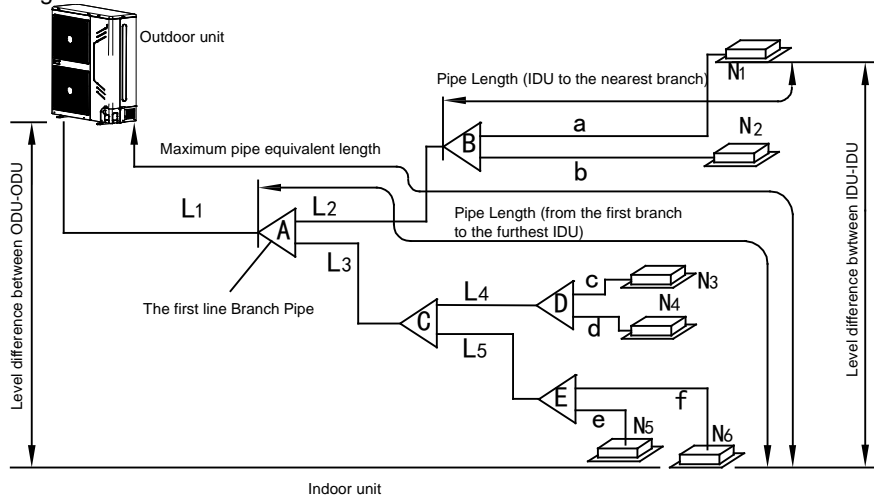

4.3 Refrigerant pipe selection

The first connecting method

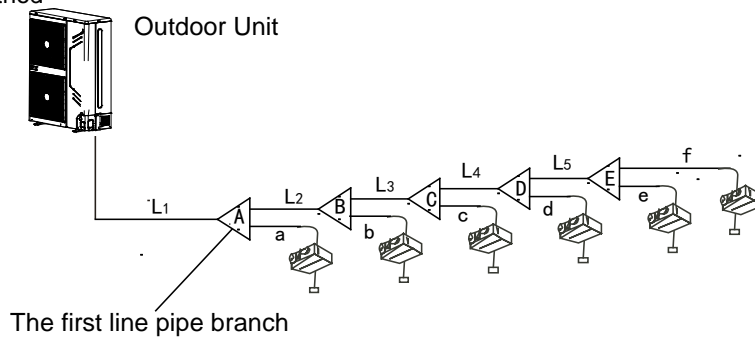

The second connecting method

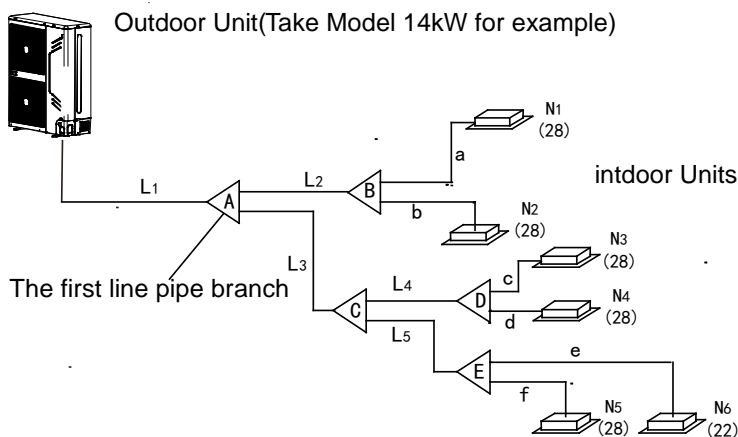

Pipe definition	Pipe connecting position	Code
Main pipe	The pipe between outdoor units to the first branch of indoor unit.	L1
The main pipes of indoor unit	The pipe after the first branch does not direct connect with the indoor unit.	L2~L5
The branch pipes of indoor unit	The pipe after the branch connects with the indoor unit.	a,b,c,d,e,f
Indoor unit branch pipes components	The pipes connect with the main pipe, the branch pipe and the main pipe of indoor unit.	A,B,C,D,E

Note: The distance between the first branch to the last indoor unit is more than 15m, choose the second connecting method. The pipe between the indoor units to the closest branch must be less than 15m.

Table 1: Indoor unit branch pipes selection (a~f)

A: Capacity of indoor units (kW)

A (kW)	Gas Side(Φ)	Liquid Side(Φ)
Wall mounted 2.2~4.5	12.7(Flaring nut)	6.4(Flaring nut)
Wall mounted 5.6	15.9(Flaring nut)	9.5(Flaring nut)
Four way cassette type 7.1~16	15.9(Flaring nut)	9.5(Flaring nut)
Four way cassette compact type 2.2~4.5	12.7(Flaring nut)	6.4(Flaring nut)
Four way cassette compact type 5.6	15.9(Flaring nut)	9.5(Flaring nut)
Duct type 2.2~4.5	12.7(Flaring nut)	6.4(Flaring nut)
Duct type 5.6~14	15.9(Flaring nut)	9.5(Flaring nut)
Ceiling & Floor 3.6~4.5	12.7(Flaring nut)	6.4(Flaring nut)
Ceiling & Floor 5.6~16	15.9(Flaring nut)	9.5(Flaring nut)

Note: The maximum length of the branch pipe should not be longer than 15m.

Table 2: Indoor unit main pipes selection (L1~L5)

Total capacity of downstream indoor units (kW)	Main pipe size(mm)		Branch Pipe
	Air pipe	Liquid pipe	
A<16.6	Φ15.9	Φ9.5	FQZHN-01C
16.6≤A<23	Φ19.1	Φ9.5	FQZHN-01C

Table 3: Main pipes selection (L1)

Total capacity of outdoor units (kW)	When the equivalent length of all liquid and air pipes < 90m			When the equivalent length of all liquid and air pipes ≥ 90m		
	gas side (mm)	liquid side (mm)	The first line branch pipe	gas side (mm)	liquid side (mm)	The first line branch pipe
A<16	Φ15.9	Φ9.5	FQZHN-01C	Φ19.1	Φ9.5	FQZHN-01C
16≤A<23	Φ19.1	Φ9.5	FQZHN-01C	Φ22.2	Φ9.5	FQZHN-02C

Note: Main pipe L1 can be selected from table 2 and table 3, the larger size should be finally selected.

The straight distance between copper pipe turning and the contiguous branch pipe is at least 0.5m;

The straight distance between the contiguous branch pipes is at least 0.5m;

The straight distance which the branch pipes connected to the indoor unit is at least 0.5m;

Table4: Outdoor unit pipe connection

MODEL	Piping side	Outdoor unit pipe connection (mm)	
		Gas Side	Liquid Side
12kW		Φ15.9	Φ9.5
14kW		Φ15.9	Φ9.5
16kW		Φ19.1	Φ9.5
18kW		Φ19.1	Φ9.5

Outdoor Unit (kW)	Maximum Quantity of Indoor unit	Total Capacity of Indoor unit
12	6	45%~100%
14	6	45%~100%
16	7	45%~100%
18	9	45%~100%

If ODU connect only one IDU, the capacity of IDU should be not more than ODU.

If ODU connect more than one IDU, the capacity of each IDU should be not more than 8kW for refrigerant uniform distribution.

When capacity of indoor unit greater than the sum of 100%, capacity of indoor unit will be attenuated.

When capacity of indoor unit greater than or equal to the sum of 120%, in order to ensure the effectiveness of machine, and then try to open the indoor units at different time.

When the capacity of indoor unit is greater than or equal to 16.8kW, the caliber of primary gas pipe should be augmented from Φ16 toΦ19.

4.4 Remove Dirt or Water in the Piping

Make sure there is no any dirt or water before connecting the piping to the outdoor units.

Wash the piping with high pressure nitrogen, never use refrigerant of outdoor unit.

4.5 Airtight Test

Charge pressured nitrogen after connecting indoor/outdoor unit piping to do airtight test.

Cautions:

1. Pressured nitrogen [4.3MPa (44kg/cm) for R410A] should be used in the airtight test.
2. Tighten high pressure/low pressure valves before applying pressured nitrogen.
3. Apply pressure from air vent mouth on the high pressure/low pressure valves.
4. The high pressure/low pressure valves are closed when applying pressured nitrogen.
5. The airtight test should never be use any oxygen, flammable gas or poisonous gas.

4.6 Vacuum

Using vacuum pump to do the vacuum and never using refrigerant to expel the air.

Vacuum should be done from both liquid side and gas side simultaneously.

4.7 Additional refrigerant charge

Calculate the added refrigerant according to the diameter and the length of the liquid side pipe of the outdoor unit/indoor unit connection.

When the outdoor unit connects one indoor unit:

Liquid Side Piping Diameter	Refrigerant to be Added Perimeter Piping
Φ6.4	0.023kg
Φ9.5	0.060kg
Φ12.7	0.120kg
Φ15.9	0.180kg
Φ19.1	0.270kg
Φ22.2	0.380kg

Note: Additional refrigerant volume of divergent pipe is 0.1kg per item (Consider the liquid side of divergent pipe only).

4.8 Leak detection

Use soap water or leak detector to check every joint whether leaks or not.

Note: A is low pressure side stop valve.

B is high pressure side stop valve.

C and D are connecting pipes interface of indoor and outdoor units.

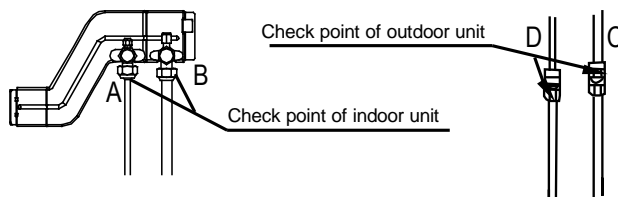

4.9 Heat Insulation

Do the heat insulation to the pipes of air side and liquid side separately. The temperature of the pipes of air side and liquid side when cooling, for avoiding condensation please do the heat insulation fully.

- The air side pipe should use closed cell foamed insulation material, which the fire-retardant is B1 grade and the heat resistance over 120°C.
- When the external diameter of copper pipe ≤ Φ12.7mm, the thickness of the insulating layer at least more than 15mm; When the external diameter of copper pipe ≥ Φ15.9mm, the thickness of the insulating layer at least more than 20mm.
- Please use attached heat-insulating materials to do the heat insulation without clearance for the connecting parts of the indoor unit pipes.

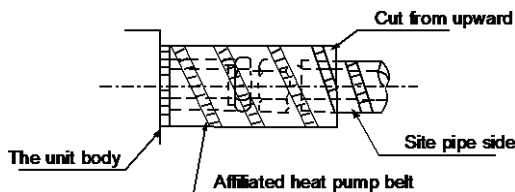

5. Electric System

5.1 Wiring Diagrams and Field Wiring

Wiring diagrams and field wiring please refer to “Wiring Diagrams and field wiring” of Part 2.

5.2 Description of Main Control Board of Outdoor unit

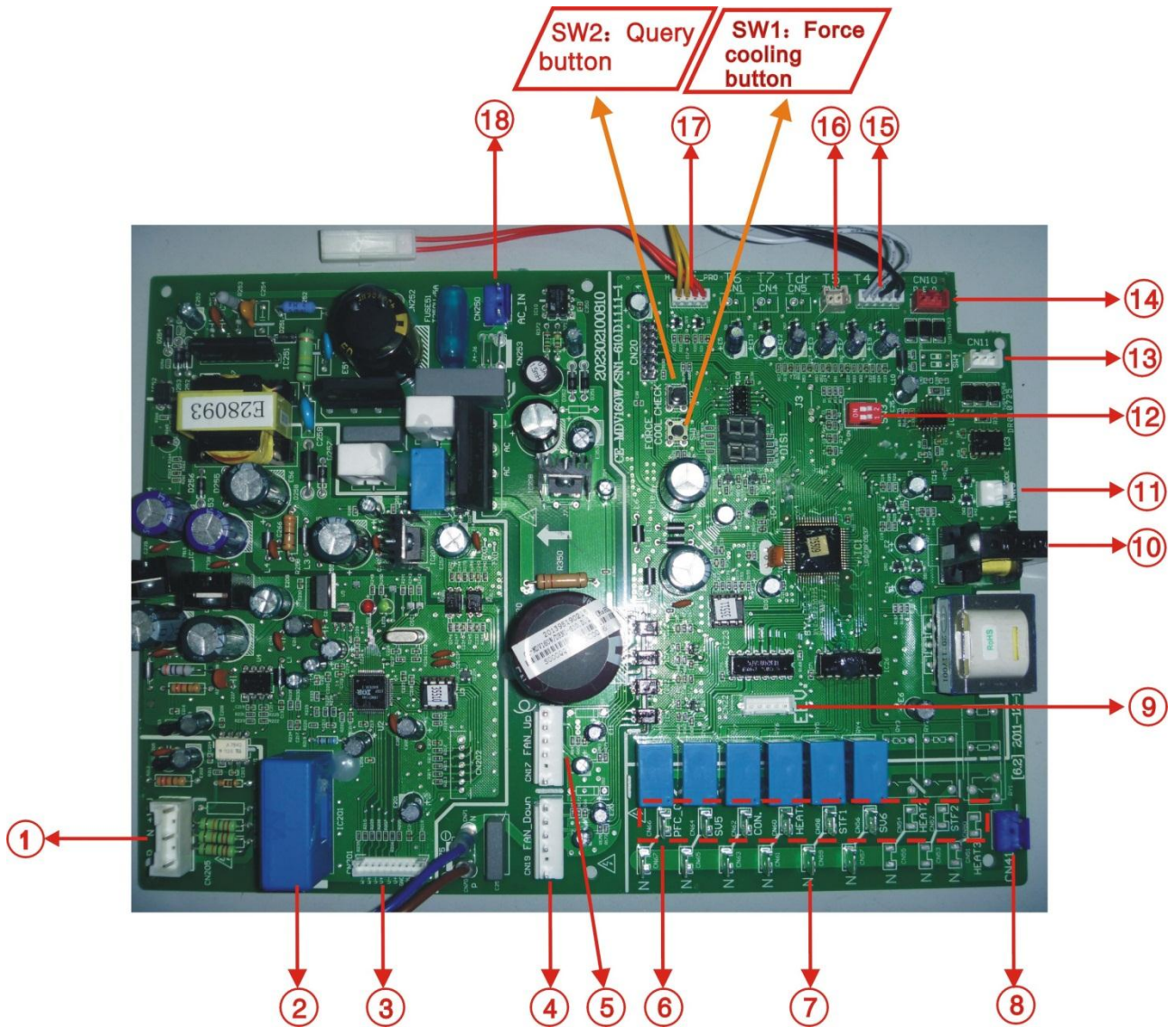

Dial codes definition

SW3 definition



SW3

SW3		
1	ON	Obtain network address automatically
	OFF	Obtain network address manually
2	ON	Revocation indoor unit network address
	OFF	/

Explanation of main board

No.	Content	No.	Content
1	Port for inverter module voltage inspection	10	Input current of the mutual inductor at the inverter compressor
2	Mutual inductor for compressor DC current	11	Reserve
3	Activation port of inverter module	12	SW3 net address code automatically
4	Port of DC fan 1	13	Internet group control of indoor units
5	Port of DC fan 2	14	Communication between indoor and outdoor units
6	Loading output terminal	15	Inspection port for outdoor ambient temp. and condenser coil temp.
7	Input for N phase power supply	16	Air discharge temp. sensed port at the compressor
8	Power supply for relay	17	Input port for system pressure inspection
9	EXV activation port	18	Input port for power supply of the main control board

5.3 SW2 Query Instruction

No.	Display content	Note	No.	Display content	Note
0	Normal display	----	10	Actual current value	----
1	Running mode	0-Standby; 2-Cooling; 3-Heating; 4-Forced Cooling	11	AD actual value of voltage	----
2	Fan speed	0-OFF	12	T2 average temperature	----
3	Capacity requirement of indoor unit	----	13	Quantity of indoor units	----
4.	Capacity requirement of revised outdoor unit	----	14	Running quantity of indoor units	----
5	T3 pipe temperature	Actual value	15	12~16kW : the last fault or protection code (if there is no fault or protection code it will be display "nn") 18kW : Model(18KW: 18)	----
6	T4 environment temperature	Actual value	16	12~16kW :"- -" displays 18kW : Priority mode (Reserved)	Query for 12~16kW ends.
7	T5 discharge temperature	If more than one hundred, only display hundred s' and tens digits.	17	18kW :Version of the program	Only for 18kW
8	Surface temperature of the cooling fin	----	18	18kW :The last fault or protection code (if there is no fault or protection code it will be display "nn")	Only for 18kW
9	Opening degree of EXV	----	19	18kW :Display "--"	Only for 18kW

Remark:

- 1) Normal display: Display frequency of compressor when capacity needing.
- 2) Running mode: 0—Standby; 2—COOLING; 3—HEATING; 4—FORCED COOLING.

- 3) Fan speed: 0—OFF; 1~7—Speed increasing in turn.
- 4) SW1: Forced cooling button.
- 5) SW2: Query button.

5.4 Description of Main Control Board of Indoor unit

There are two shapes of main control board that used to all types of indoor unit matching with V4+ outdoor unit.

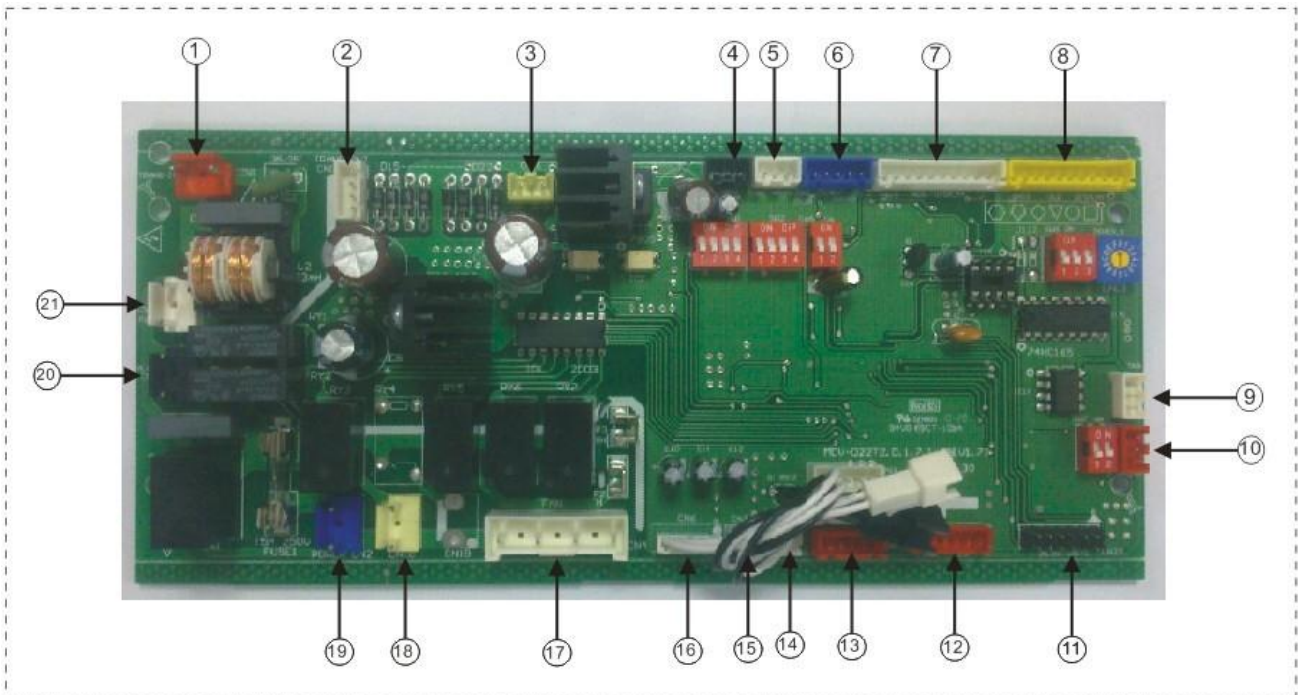

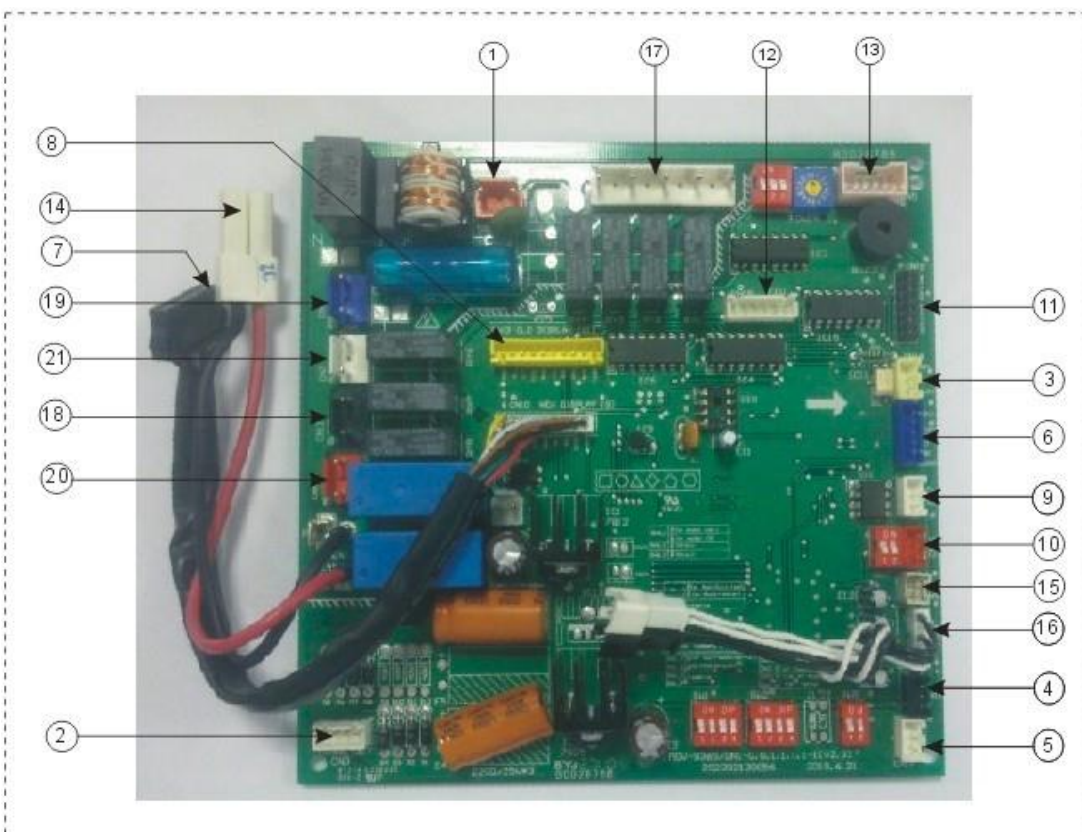

Shape 1





Shape 2

Dial codes definition

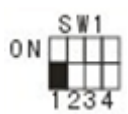
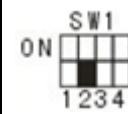
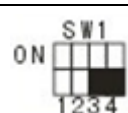
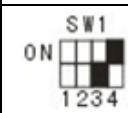

0/1 definition

	Means 0
	Means 1

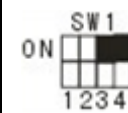

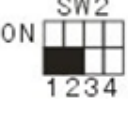
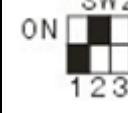
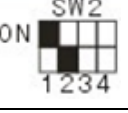
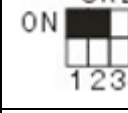

SW1 definition

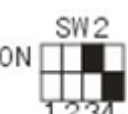
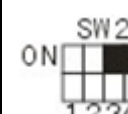
	1 means factory test mode 0 means default auto addressing mode		1 means DC fan is chosen 0 means AC fan is chosen
	00 means DC fan static pressure is 0 (reserved)		01 means DC fan static pressure is 1 (reserved)
	10 means DC fan static pressure is 2 (reserved)		11 means DC fan static pressure is 3 (reserved)

SW2 definition

	00 means shutting down the unit to stop cold air at 15°C		01 means shutting down the unit to stop cold air at 20°C
	10 means shutting down the unit to stop cold air at 24°C		11 means shutting down the unit to stop cold air at 26°C
	00 means the time of stopping fan (when no capacity need) is 4 minutes		01 means the time of stopping fan (when no capacity need) is 8 minutes
	10 means the time of stopping fan (when no capacity need) is 12 minutes		11 means the time of stopping fan (when no capacity need) is 16 minutes

SW5 definition

	00 means temperature compensation value is 6°C under heating mode		01 means temperature compensation value is 2°C under heating mode
	10 means temperature compensation value is 4°C under heating mode		11 means temperature compensation value is 8°C under heating mode



SW6 definition

	1 means old display panel 0 means new display panel		Reserved
---	--	---	-----------------

SW7 definition

	<p>Normal configuration</p>		<p>Last unit of the network</p>
---	------------------------------------	---	--

J1 J2 definition

	<p>Without jumper J1 for auto restart function</p>		<p>With jumper J1 for non-auto restart function</p>
	<p>reserved</p>		

Error code & indication

Error code	Lamp indication	Content
FE	Time LED and run LED flash together	Without address when first time power on
H0	4 LED flash together	M_Home non-matching
E0	Defrost LED flashes	Modes conflict
E1	Timer LED flashes	Communicative error between indoor and outdoor units
E2	Run LED flashes	Temperature sensor T1 error
E3	Run LED flashes	Temperature sensor T2 error
E4	Run LED flashes	Temperature sensor T2B error
E7	Defrost LED flash slowly	EEPROM error
Ed	Alarm LED flashes slowly	Outdoor unit error
EE	Alarm LED flash	Water level alarm

Note: Some unit that has digital tube will show the error code when error occurs, others show lamp indication.

Explanation of main board

No.	Content	No.	Content
1	Power input of transformer	12	Electric expansion valve drive port
2	Power output of transformer	13	Swing motor drive ports
3	Port for remote ON/OFF switch	14	Port for electric auxiliary heater
4	Port for infrared sensor	15	Indoor evaporator outlet pipe temp. detect port
5	Water level switch	16	Indoor ambient and evaporator middle part temp. detect port
6	Port for network module	17	Port for indoor fan motor
7	Port for new display board	18	Reserved
8	Port for old display board	19	Power input port
9	Communication port of X Y E	20	Port for alarm
10	Communication port of P Q E	21	Port for water pump
11	Port for on-line writing program	—	

New Added Function—Auto Addressing

- 1) New Auto-Addressing is just a newly designed indoor-address distributed method which will automatically be done by outdoor unit, without manual addressing. When the unit is under testing, as the outdoor and indoor units are powered on simultaneously, the outdoor unit will automatically distribute different address to every indoor unit in less than 10 minutes.
- 2) With regarding to the customer’s desire of some kind fixed address or regular addresses for all indoor units, it can be achieved by wireless remote controller.
- 3)



5.5 Electric Wiring Installations

5.5.1 Highlights of electrical installation

- 1) Please separately design the special power of indoor units and outdoor units.
- 2) The power adopts special circuit, and installs creepage protector and manual switch.
- 3) The indoor units' power, creepage protector and manual switch connecting to the same outdoor unit must be general. All indoor units must be the same circuit, and must simultaneously on or off; otherwise, system life will seriously effect, and appear the situation not to solve.
- 4) The communication line between indoor units and outdoor units please use 3 core shielded wiring, while don't use the multi core wiring without shielded affect, for the interference is reduced each other
- 5) Purchased wiring, parts and materials should be in compliance with the local and national regulations.
- 6) All field wiring construction should be finished by qualified electrician.
- 7) Air conditioning equipment should be grounded according to the relevant local and national electrical regulations.
- 8) Current leakage protection switch should be installed (select current leakage breaker in light of the 1.5-2 times of total loading rated current.)
- 9) When connecting wiring and wire holder, use cable clamp to fix and make sure no exposure.
- 10) Refrigerant piping system and wiring system of indoor and outdoor unit belongs to the different system.
- 11) Do not connect the power wire to the terminal of signal wire.
- 12) When power wire is parallel with signal wire, put wires to their own wire tube and remain proper gap (the current capacity of power wire is: 10A below 300mm, 50A below 500mm).
- 13) Voltage discrepancy of power wire terminal (side of power transformer) and end voltage (side of unit) should be less than 2%. If its length could not be shortened, thicken the power wire. Voltage discrepancy between phases shall not pass 2% rated value and Current discrepancy between highest and lowest phase should be less than 3% rated value.

5.5.2 Selection of wiring

1. The selection of wiring area shall in accordance with the requirements below:
 - 1) Voltage loss of wire shall meet the requirement of terminal voltage for normal operation and startup.
 - 2) The wiring current-carrying capacity determined by installed method and environment is not less than the largest current of unit.
 - 3) Conductor shall ensure the stability of movement and heating.
 - 4) The conductor's smallest sectional area should satisfy the requirement of mechanical strength.
- When earth protection line (shortly called PE line) is made of material the same as phase line, the smallest sectional area of PE line should be in accordance with the regulation below:

Sectional area of core to phase lines(mm ²)	Smallest sectional area of PE line(mm ²)
$S \leq 16$	S
$16 < S \leq 35$	16
$S > 35$	S/2

5.5.3 Distribution highlights of distribution wiring

1. When distributing wiring, select wirings with different colors for phase line, zero line and protection earth according to relevant regulations.
2. The power wire and control wire of concealed engineering is prohibited to bind together with refrigerant piping. It is necessary to pass through wire tube and be distributed separately, and the gap between control line and power wire should be 500mm at least.
3. When distributing wiring by passing through pipe, the following should be paid attention to:
 - 1) Metal wire tube could be used in indoor and outdoor, but it is not suitable to the place with acid – alkali corrosion.
 - 2) Plastic wire tube is generally used in indoor and place with corrosion, but it is not suitable to situation with mechanical damage.
 - 3) The wiring through pipe shall not be in the form with ends jointing. If there must be joint, connection box should be installed at the corresponding place.

- 4) The wiring with different voltage should not pass through the same wire tube.
- 5) Total sectional area of wiring through wire tube shall not exceed 40% valid area of stuffing tube.
- 6) Fixing point of wire tube support shall follow the standard below:

Normal diameter of wire tube Mm	Largest gap between fixed points of wire tube	
	Metal pipe	Plastic pipe
15~20	1.5m	1m
25~32	2m	1.5m
40~50	2.5m	2m

5.5.4 Outdoor unit power wiring selection

1) Separate Power Supply without power facility.

Model	Power	The shortest wiring diameter (mm)			Manual switch (A)		Creepage protector
		≤20m	≤50m	GND	Capacity	Fuse	
8KW	220V,1N~50Hz/ 220V,1N,60Hz	2*2.5	2*3.0	4.0	30	25A	<100mA,0.1sec
10.5KW		2*2.5	2*3.0	4.0	30	25A	<100mA,0.1sec
12KW		2*3.3	2*4.0	4.0	50	40A	<100mA,0.1sec
14KW		2*3.3	2*4.0	4.0	50	40A	<100mA,0.1sec
16KW		2*3.3	2*4.0	4.0	50	40A	<100mA,0.1sec

Model	Power	The shortest wiring diameter (mm)			Manual switch (A)		Creepage protector
		≤20m	≤50m	GND	Capacity	Fuse	
12KW	380~415V/3N/50Hz	4*3.3	4*4.0	4.0	30	25A	<100mA,0.1sec
14KW	380~415V/3N/50Hz	4*3.3	4*4.0	4.0	30	25A	<100mA,0.1sec
16KW	380~415V/3N/50Hz	4*3.3	4*4.0	4.0	30	25A	<100mA,0.1sec
18kW	380~415V/3N/50Hz	4*3.3	4*4.0	4.0	30	25A	<100mA,0.1sec

Note: The length in the table equals the value of power cord connecting outdoor units, indicating the condition that the voltage dropping range is within 2%. If the length exceeds the above figure, please select the wire diameter according to relevant standard.

2) With power facilities.

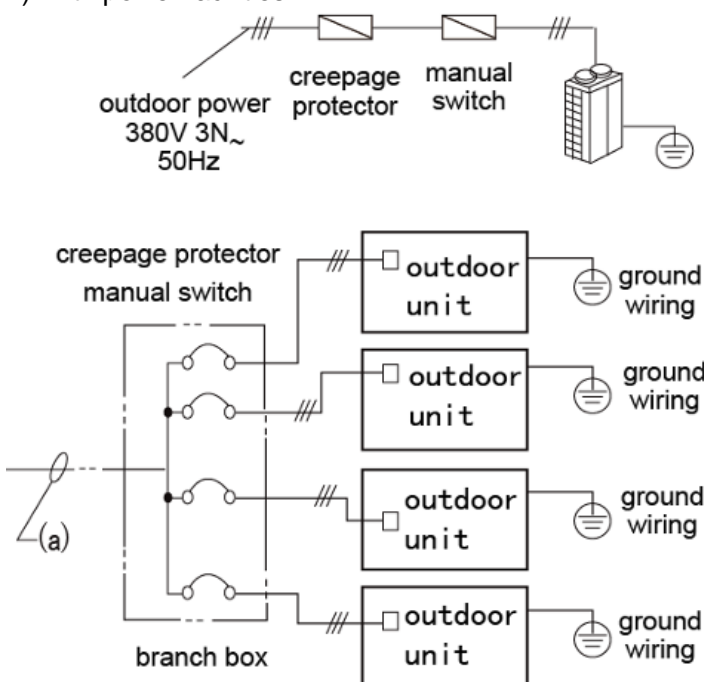

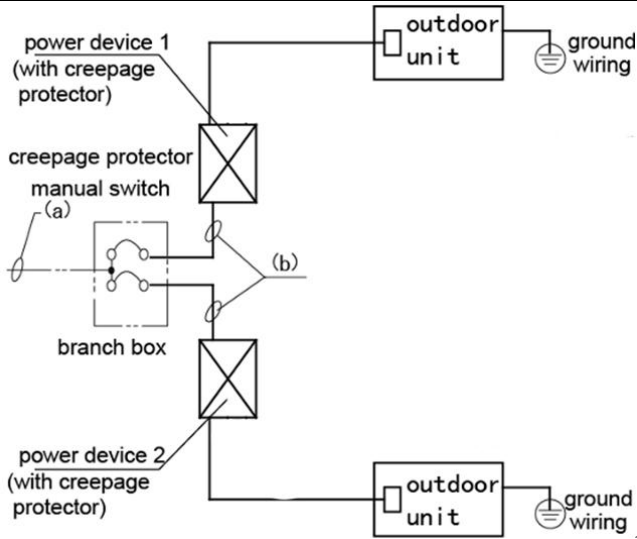

5.5.5 Indoor unit power wiring selection

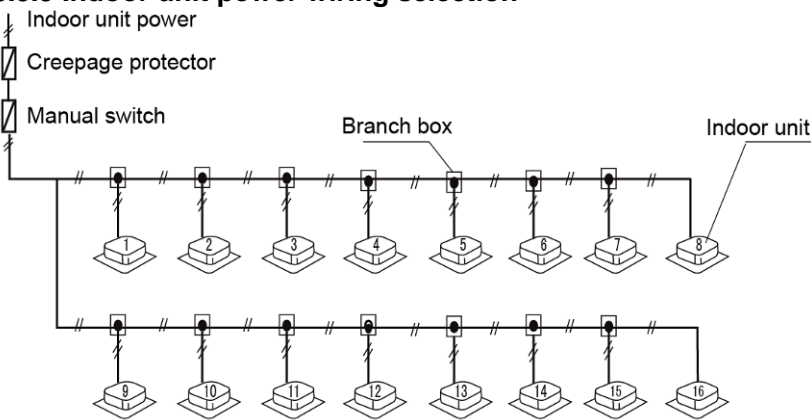

Note:

- 1) Set refrigerant piping system, signal wires between indoor unit, and that between outdoor units into one system.
- 2) Please do not put the signal wire and power wire in the same wire tube; keep distance between the two tubes. (Current capacity of power supply: less than 10A--300mm, less than 50A--500mm.)
- 3) Make sure to set address of outdoor unit in case of parallel multi-outdoor units.

CAUTION

- Please select power source for indoor unit and outdoor unit respectively
 - The power supply has specified branch circuit with leakage protector and manual switch.
- Indoor unit connect with power supply which is 220-240V~50Hz. Outdoor unit connect with power supply which is 380-415V~50Hz (Please set all the indoor unit power supply of one system into the same circuit. It should turn on or shut down the unit at the same time, otherwise, the service life would affect seriously, even the unit may not turn on.)
- Please put the connective wire system between indoor unit and outdoor unit with the refrigerant system together.
 - Use 3-core screened wire as indoor and outdoor control wire.
 - The installation should comply with relevant national electric standard.
 - Power wiring should be engaged by professional electrician.

6. Outdoor Unit Wiring

6.1 The Specification of Power

Table 6-1

Capacity		12kW-16kW	18kW
Outdoor Unit power	Phase	3 phase	3 phase
	Voltage and Frequency	380-415V~ 50Hz	380-415V~ 50Hz
	Power Wiring(mm ²)	5-core X2.5	5-core X2.5
Circuit Breaker/Fuse (A)		25	32
Indoor unit/Outdoor unit Signal wire (Weak electric signal) (mm ²)		3-core shielded wire 3X0.75	3-core shielded wire 3X0.75

CAUTION

A disconnection device having an air gap contact separation in all active conductors should be incorporated in the fixed wiring according to the National Wiring Regulation.

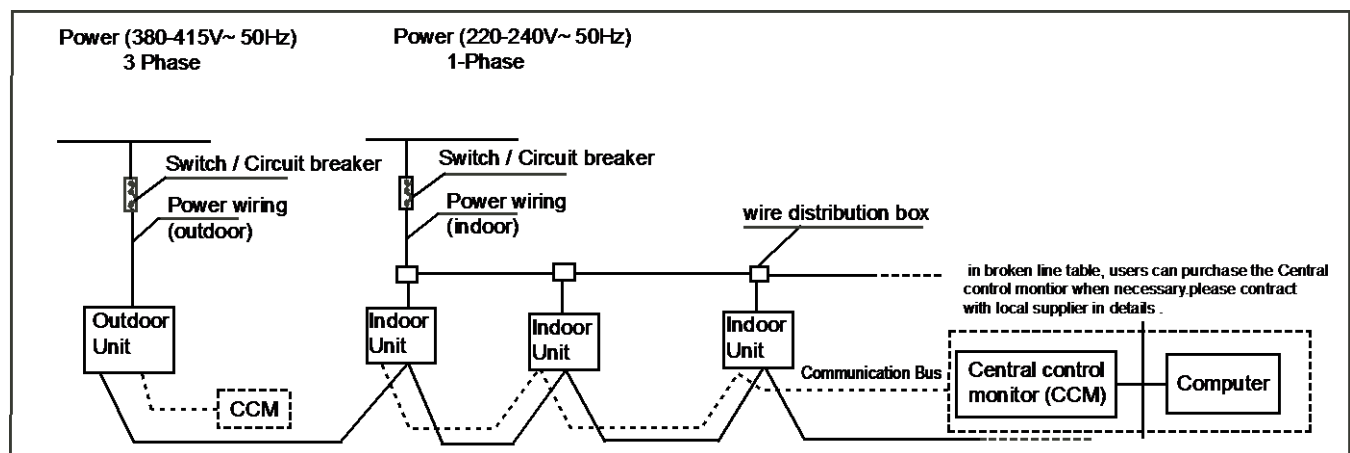

Fig.6-1

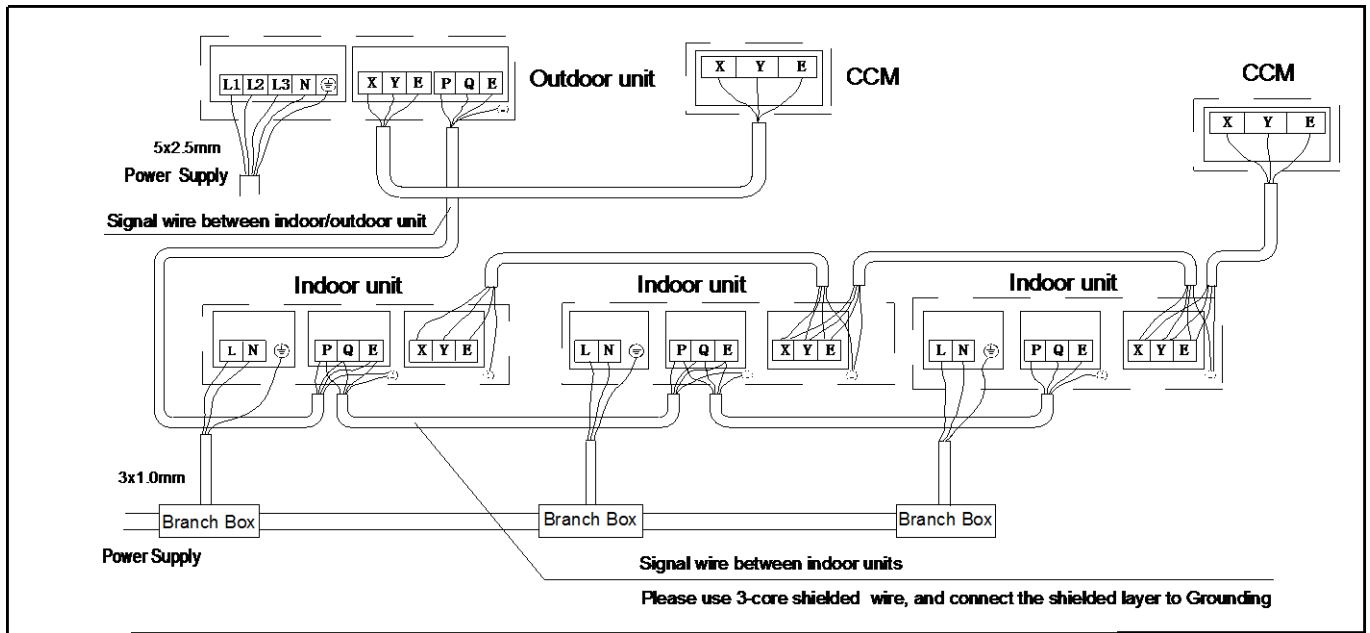

Fig.6-2

CAUTION

The reserved function is indicated in broken line table, users can select it when necessary.

Indoor/Outdoor Unit Signal Wire

Connect the wire according to their numbers. Wrong connection may cause malfunction.

Wiring Connection

Seal the wiring connection with the insulation material, or the condensing dew will be caused.

NOTE

The air-conditioners can connect with Central Control Monitor (CCM). Before operation, please wiring correctly and set system the air-conditioners can connect with Central Control Monitor (CCM). Before operation, please wiring correctly and set system

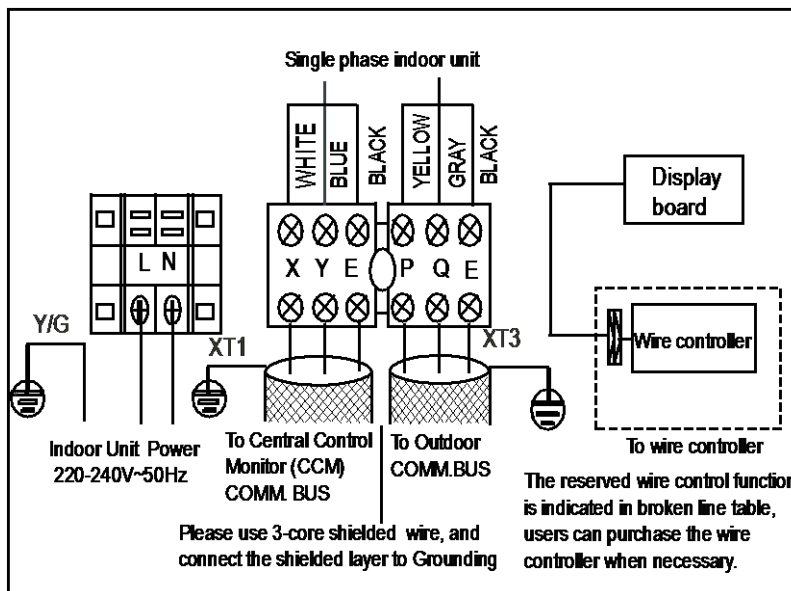

Fig.6-3

6.2 Indoor Unit Wiring

Power Supply

Table 6-2

Capacity (kW)		1.8~16
indoor Unit power	Phase	1- phase
	Frequency and Voltage	220-240V~ 50Hz
	Power Wiring(mm²)	3-corex1.0
Circuit Breaker (A)		16
Indoor unit/Outdoor unit Signal wire (Weak electric signal) (mm²)		3-core shielded wire 3X0.75

- 1.Signal wire is 3-core, polarized wire. Use 3-core shield wire to prevent interference. The grounding method now is grounding the closed end of the shield wire and opening (insulating) at the end. Shield is to be grounded.
- 2.The control between outdoor unit and indoor unit is BUS type. An address is set on field during the installation.

CAUTION

The wire diameter and continuous length are under the condition that the voltage vibration is within 2%. If the continuous length is exceed showing value, choose the wire diameter follow relevant regulation.

Indoor unit power supply wiring

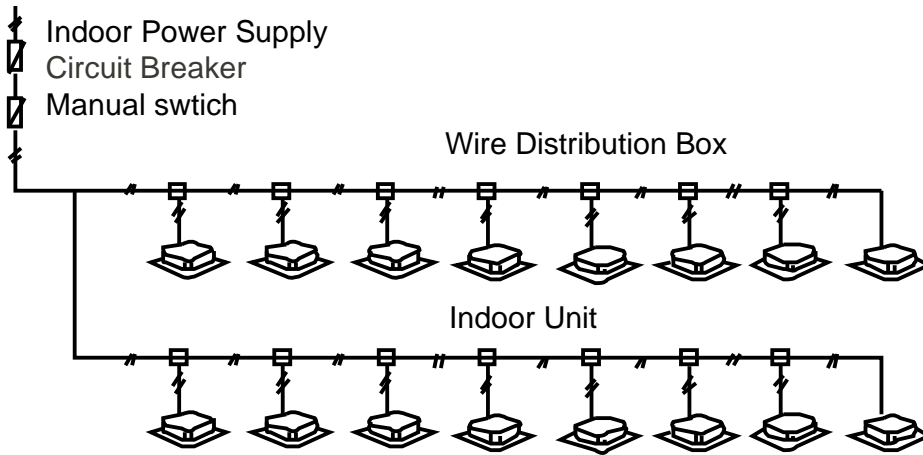
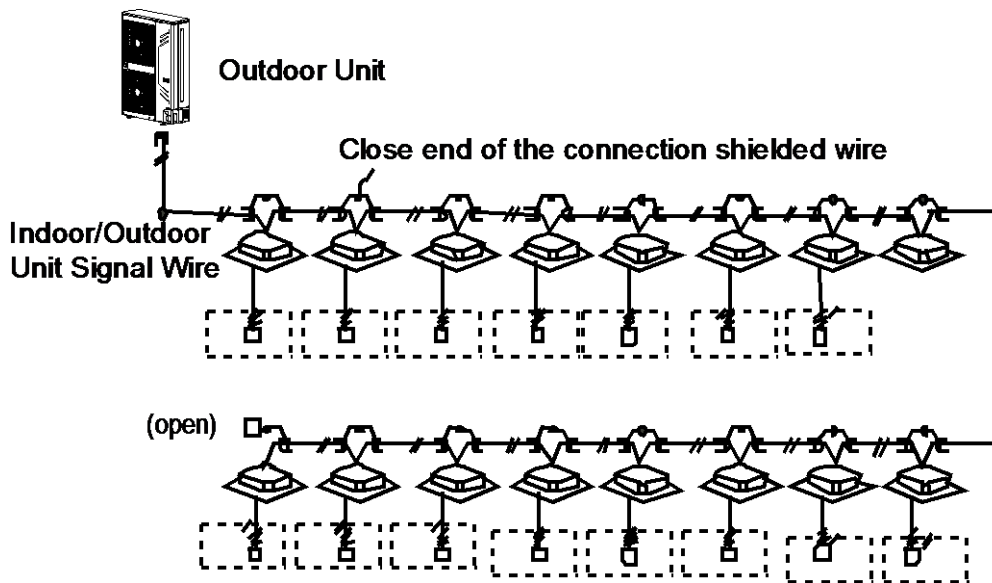

Fig.6-4

CAUTION

1. Refrigerant piping system, indoor unit-indoor unit connection signal wires and indoor unit-outdoor unit connection signal wire are in the same system.
2. When power cord is parallel with signal wire, please put them into separate wire distribution pipes, and leave a proper distance. (Reference distance: It is 300mm when current capacity of power cord is less than 10A, or 500mm when 50A).
Please use shield wire as indoor unit/outdoor unit signal wire.

Indoor/Outdoor unit signal wire wiring



in broken line table, users can purchase the wire controller when necessary.

Fig.6-5

7. Test Running

Operate according to “key points for test running” on the electric control box cover.

CAUTION

- Test running cannot start until the outdoor unit has been connected to the power for 12hours.
- Test running cannot start until all the valves are affirmed open.
- Never make the test running if the machine has malfunction.
- Make sure the communication between the indoor unit and outdoor unit is normal before test running.

8. Precautions on Refrigerant Leakage

This air conditioner (A/C) adopts innocuous and nonflammable refrigerant. The locating room of the A/C should be big enough that any refrigerant leakage is unable to reach critical thickness. So certain essential action can be taken on time.

Refrigerant critical thickness: 0.44[kg/m³] for R410A.

Confirm the critical thickness through follow steps, and take necessary actions.

1. Calculate the sum of the charge volume (A[kg]) Total Refrigerant volume of 10HP=factory refrigerant volume + super addition
2. Calculate the indoor cubage (B[m³]) (as the minimum cubage).
3. Calculate the refrigerant thickness

$$\frac{A[\text{kg}]}{B[\text{m}^3]} \leq \text{critical thickness}$$

Counter measure against over high thickness

1. Install mechanical ventilator to reduce the refrigerant thickness under critical level. (ventilate regularly)
2. Install leak alarm facility related to mechanical ventilator if you cannot regularly ventilate.

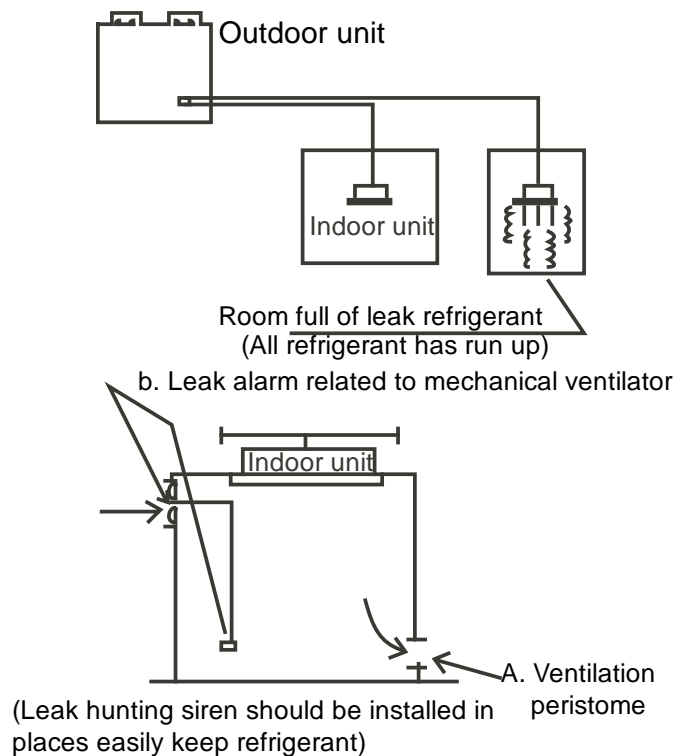

NOTE

Please press "constraint cool" button to carry out refrigerant recycling process. Keep the low pressure above 0.2MPa; otherwise compressor may be burnt out.