

1. Model Line Up

Outdoor units (Individual Unit):



2. Maximum Indoor Units Table

Capacity (HP)	Model	Max. indoor units nos.
18	MDVi-530W/DRN1-i	20
20	MDVi-560W/DRN1-i	24
30	MDVi-850W/DRN1-i(B)	32

3. Capacity Range of Indoor Units

Power supply of all the indoor units is 1 phase, 220-240V or 3 phase, 380-415V, 50Hz

Capacity (kW)	2.2	2.8	3.6	4.5	5.6	7.1	8.0	9.0	10.0	11.2	12.5	14.0	16.0	20.0	25.0	28.0
BTU/H	7500	9600	12300	15400	19100	24200	27300	30700	34100	38200	42600	47800	54600	68200	85300	95500
Ton	0.6	0.8	1	1.3	1.6	2.0	2.3	2.6	2.9	3.2	3.5	4.0	5.0	5.7	7.1	8
HP	0.8	1	1.25	1.6	2	2.5	2.8	3.2	3.6	4	4.4	5	6	8	9	10
INDEX	22	28	36	45	56	71	80	90	100	112	123	140	160	200	250	280
One-way Cassette		✓	✓	✓	✓	✓										
Two-way Cassette	✓	✓	✓	✓	✓	✓										
Compact Four-way Cassette	✓	✓	✓	✓												
Four-way Cassette Type	✓	✓	✓	✓	✓	✓	✓	✓	✓	✓		✓				
Low Static Pressure Duct *	✓	✓	✓	✓	✓											
Ductable Unit A5 Type	✓	✓	✓	✓	✓	✓	✓	✓	✓	✓		✓				
High Static Pressure Duct						✓	✓	✓	✓	✓		✓	✓	✓	✓	✓

Ceiling & Floor			✓	✓	✓	✓	✓	✓	✓	✓	✓		✓	✓			
Wall-mounted -S Type	✓	✓	✓	✓	✓												
Wall-mounted -C Type	✓	✓	✓	✓	✓												
Console	✓	✓	✓	✓													
Concealed Floor-standing	✓	✓	✓	✓	✓	✓	✓										
Exposed Floor-standing	✓	✓	✓	✓	✓	✓	✓										
Exposed Floor-standing (New panel)	✓	✓	✓	✓	✓	✓	✓										
Fresh Air processing Unit												✓	✓		✓	✓	✓

Part 2 Selection Procedure

1 Introduction.....24

2 Unit selection (Based on cooling load).....27

1 Introduction

1.1 Model Selection Procedure

Select the model and calculate the capacity for each refrigerant system according to the procedure shown below.

- Calculation of the indoor air-conditioning load, Calculate the maximum air-conditioning load for each room or zone.

Selection of an air conditioning system

- Select the ideal air conditioning system for air conditioning of each room or zone

Design of the control system

- Design a suitable control system for the selected air conditioning system

Preliminary selection of indoor and outdoor units

- Make preliminary selections that are within the allowable range for the system

Check of the tubing length and elevation difference

- Check that the length of refrigerant tubing and the elevation difference are within the allowable ranges

Calculation of the corrected outdoor unit capacity

- Capacity correction coefficient for model, outdoor temperature conditions, tubing length and elevation difference

Calculation of the actual capacity for each indoor unit

- Calculate the corrected indoor/outdoor capacity ratio, based on the corrected outdoor unit capacity and the total corrected capacity of all indoor units in the same system

Recheck of the actual capacity for each indoor unit

- If the capacity is inadequate, reexamine the unit combinations.

1.2 Indoor Unit Selection

Enter INDOOR UNIT CAPACITY TABLES at given indoor and outdoor temperature. Select the unit that the capacity is the nearest to and greater than given load.

Note:

Individual indoor unit capacity is subject to change by the combination. Actual capacity has to be calculated according to the combination by using outdoor unit capacity table.

1.2.1 Calculation of Actual Capacity of Indoor Unit

Because the capacity of a multi air-conditioner changes according to the temperature conditions, tubing length, elevation difference and other factors, select the correct model after taking into account the various correction values. When selecting The model, calculate the corrected capacities of the outdoor unit and each indoor unit. Use the corrected outdoor unit capacity and the total corrected capacity of all the indoor units to calculate the actual final capacity of each indoor unit.

Find the indoor unit capacity correction coefficient for the following items

- Capacity correction for the indoor unit temperature conditions
From the graph of capacity characteristics, use the indoor temperature to find the capacity correction coefficient.
- Capacity distribution ratio based on the indoor unit tubing length and elevation difference.
First, in the same way as for the outdoor unit, use the tubing length and elevation difference for each indoor unit to find the correction coefficient from the graph of capacity change characteristics

Capacity distribution ratio for each indoor unit = Correction coefficient for that indoor unit / Correction coefficient for the outdoor unit

1.3 Outdoor Unit Selection

In general, outdoor unit can be selected as follows though the location of the unit, zoning and usage of the rooms

may be considered.

The indoor and outdoor unit combination is determined that the sum of indoor unit capacity index is nearest to and smaller than the capacity index at 100% combination ratio of each outdoor unit. Up to 8~16 indoor units can be connected to one outdoor unit. It is recommended to choose a larger outdoor unit if the installation space is large enough.

If the combination ratio is greater than 100%, the indoor unit selection shall be reviewed by using actual capacity of each indoor unit.

OUTDOOR UNIT TOTAL CAPACITY INDEX TABLE

Outdoor Unit	Indoor Unit Combination Ratio (kW)								
	130%	120%	110%	100%	90%	80%	70%	60%	50%
18HP	69.2	63.8	58.5	53.2	47.9	42.6	37.2	31.9	26.6
20HP	72.8	67.2	61.6	56.0	50.4	44.8	39.2	33.6	28.0
30HP	109.2	100.8	92.4	84	75.6	67.2	58.8	50.4	42

INDOOR UNIT CAPACITY INDEX

Unit Size	Model 22	Model 28	Model 36	Model 45	Model 56	Model 71	Model 80	Model 90	Model 112	Model 140
Capacity Index (kW)	2.2	2.8	3.6	4.5	5.6	7.1	8.0	9.0	11.2	14.0
Unit Size	Model 160	Model 200	Model 250	Model 280						
Capacity Index (kW)	16	20	25	28						

1.4 Actual Performance Date

Use OUTDOOR UNIT CAPACITY TABLES.

Determine correct table according to the outdoor unit model and combination ratio.

Enter the table at given indoor and outdoor temperature and find the outdoor unit capacity and power input. The individual indoor unit capacity (power input) can be calculated as follows.

$$IUC = OUC \times INX / TNX$$

Where,

IUC: Each indoor unit capacity

OUC: Outdoor unit capacity

INX: Each indoor unit capacity index

TNX: Total capacity index

Then, correct the indoor unit capacity according to the piping length.

If the corrected capacity is smaller than the load, the size of indoor unit has to be increased and repeat the same selection procedure.

1.5 Variation in capacity in accordance with the length of refrigerant pipe

1.5.1 Cooling capacity modification

Modification coefficient of the length and height difference of refrigerant pipe:

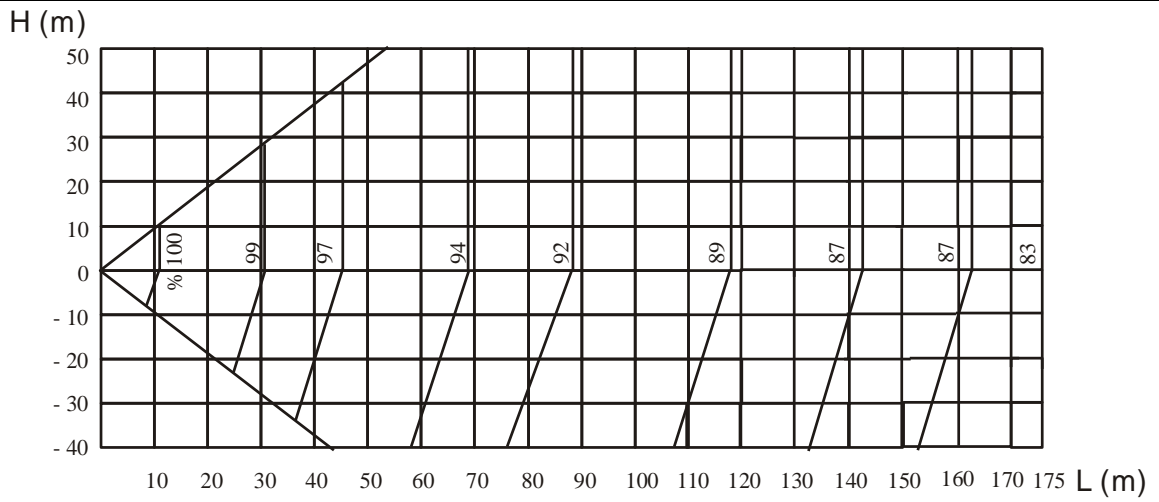

L: Refrigerant pipe equivalent length

H: Height difference between outdoor and indoor

1.5.2 Heating capacity modification

Modification coefficient of the length and height difference of refrigerant pipe:

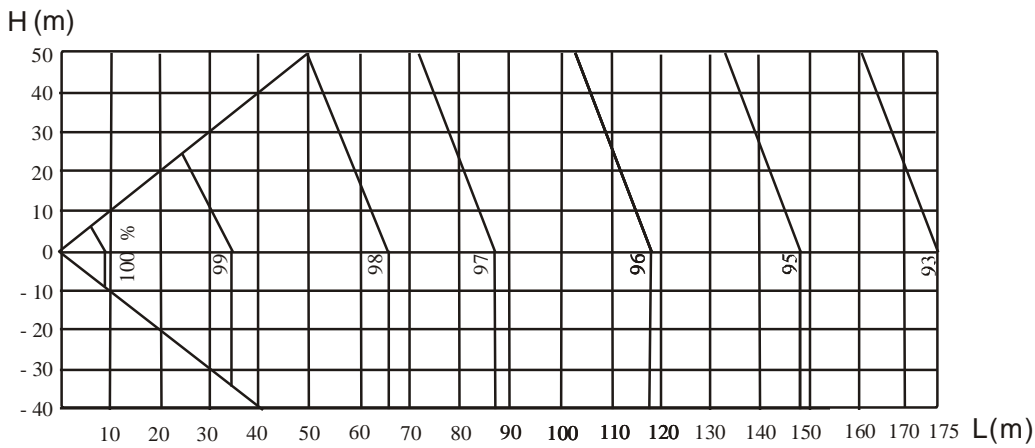

L: Refrigerant pipe length

H: Height difference between outdoor and indoor

2 Unit selection (Based on cooling load)

2.1 Given condition

2.1.1 Design condition (Cooling: Indoor 20°C (WB), Outdoor 35°C (DB))

2.1.2 Cooling load

Location	Room A	Room B	Room C	Room D	Room E	Room F
Load (kW)	2.1	2.8	3.5	4.6	5.8	7.2

2.1.3 Power supply unit: Outdoor 380~415V-3Ph-50Hz, Indoor 220~240V-1Ph-50Hz.

2.1.4 Pipe length: 50m

2.1.5 Height difference: 30m

2.2 Indoor unit selection

Select the suitable capacity for condition of 'Indoor 20°C (WB), Outdoor 35°C (DB)' using indoor unit capacity table. The selected result is as follows. (Assuming the indoor unit type is duct)

Location	Room A	Room B	Room C	Room D	Room E	Room F
Load (kW)	2.1	2.8	3.5	4.6	5.8	7.2
Unit size	22	28	36	45	56	71
Capacity (kW)	2.3	2.9	3.7	4.8	6.0	7.5

2.3 Outdoor unit selection

2.3.1 Assume the indoor unit and outdoor unit combination as follows

2.3.1.1 Calculate the total nominal capacity of indoor units in the combination according to the above table:

$$2.2 \times 1 + 2.8 \times 1 + 3.6 \times 1 + 4.5 \times 1 + 5.6 \times 1 + 7.1 \times 1 = 25.8 \text{ kW}$$

2.3.1.2 Select outdoor unit: MDV-280(10)W/DRN1(B) which has nominal cooling capacity: 28kW.

Calculate the proportion between ① and ②: $25.8/28 = 92\%$

2.3.2 Result : Because the proportion is within 50~130%, it is a "Right" selection.

2.3.3 Real function data with indoor unit combination

- For the 92% combination, calculate the cooling capacity of outdoor unit (MDV-280(10)W/DRN1(B)).

$$26.65 \text{ kW} \leftarrow 90\% \text{ (Indoor temperature : WB } 20^\circ\text{C, Outdoor temperature: DB } 35^\circ\text{C)}$$

$$29.61 \text{ kW} \leftarrow 100\% \text{ (Indoor temperature : WB } 20^\circ\text{C, Outdoor temperature: DB } 35^\circ\text{C)}$$

Then calculated the outdoor capacity in 92% combination index:

$$\text{Therefore: } 26.65 + \{(29.61 - 26.65) / 10\} \times 2 = 27.24;$$

- Outdoor unit (MDV-280(10)W/DRN1(B)) cooling temperature: DB 35°C
- Capacity modification coefficient with pipe length (50m) and height difference (30m): 0.958
- Each indoor unit cooling capacity

$$\text{MDV-D22T2: } 27.24 \times 22/258 \times 0.958 = 2.22 \text{ (kW)}$$

$$\text{MDV-D28T2: } 27.24 \times 28/258 \times 0.958 = 2.83 \text{ (kW)}$$

$$\text{MDV-D36T2: } 27.24 \times 36/258 \times 0.958 = 3.64 \text{ (kW)}$$

$$\text{MDV-D45T2: } 27.24 \times 45/258 \times 0.958 = 4.55 \text{ (kW)}$$

$$\text{MDV-D56T2: } 27.24 \times 56/258 \times 0.958 = 5.66 \text{ (kW)}$$

$$\text{MDV-D71T2: } 27.24 \times 71/258 \times 0.958 = 7.18 \text{ (kW)}$$

Location	Room A	Room B	Room C	Room D	Room E	Room F
----------	--------	--------	--------	--------	--------	--------

Load (kW)	2.1	2.8	3.5	4.6	5.8	7.2
Unit size	22	28	36	45	56	71
Capacity (kW)	2.22	2.83	3.64	4.55	5.66	7.18

2.4 Conclusion

Generally, we think this result is acceptable, so we can think we have accomplished the calculation. But if you think this result is not acceptable, you can repeat the above process.

Remark: In this sample, we don't consider the other capacity modification index and assume them are 1.0.

For more details about the effect factor such as outside ambient/inside ambient DB/WD , please refer to the performance table of indoor and outdoor units.

Part 3 Specification & Performance

1 Specifications.....	22
2 Dimensions.....	32
3 Piping Diagrams.....	40
4 Electric Characteristics	43
5 Wiring Diagrams and Field Wiring	44
6 Operation Limits.....	51
7 Capacity Tables	52
8 Sound Levels.....	100
9 Outdoor Fan Performance	102
10 Optional Accessories.....	103
11 Functional parts and safety devices.	104

1. Specifications

Model			MDV-530W/DRN1-i(B)	MDV-560W/DRN1-i(B)
Power supply		V-Ph-Hz	380~415V 3Ph ~ 50Hz	380~415V 3Ph ~ 50Hz
Cooling (*1)	Capacity	W	53000	56000
	Input	W	16000	17000
	EER	W/W	3.31	3.3
	IPLV	W/W	3.75	3.64
Heating (*2)	Capacity	W	59000	63000
	Input	W	14900	16000
	COP	W/W	3.96	3.94
Max. input consumption		W	24700	24700
Max. current		A	42	50
DC Inv. compressor	Model		E405DHD-36D2YG	E405DHD-36D2YG
	Quantities		1	1
	Type		DC Inv	DC Inv
	Brand		Hitachi	Hitachi
	Capacity	Btu/h	11800	11800
	Input	W	3665	3665
	Power supply	V-Ph-Hz	380-415V~3Ph, 50Hz	380-415V~3Ph, 50Hz
	Operating frequency	Hz	48~230	48~230
	Crankcase	W	33*2	33*2
	Refrigerant oil	ml	FVC68D / 500	FVC68D / 500
Fixed scroll compressor	Model		E605DH-59D2YG	E605DH-59D2YG
	Quantities		3	3
	Type		Fixed scroll	Fixed scroll
	Brand		Hitachi	Hitachi
	Capacity	W	15390×3	15390×3
	Input	W	5130×3	5130×3
	Power supply	V-Ph-Hz	380-415V~3Ph, 50Hz	380-415V~3Ph, 50Hz
	Locked rotor ampere (LRA)	A	62×3	62×3
	Thermal protector type		Inner	Inner
	Crankcase	W	33*3	33*3
	Refrigerant oil	ml	FVC68D / 500×3	FVC68D / 500×3
Outdoor fan motor	Model		YDK450-6C	YDK450-6C
	Type		AC, 3 phase	AC, 3 phase
	Brand		Da Yang	Weiling
	Quantities		2	2
	Insulation class		F	F
	Safe class		IPX4	IPX4
	Input	W	770×2	770×2
	Output	W	450×2	450×2
	Capacitor	uF	25 uF	25 uF
	Rated current	A	3.42×3	3.42×3
	Speed	r/min	840	840
Outdoor fan	material		Plastic	Plastic
	Type		Axial	Axial
	Fan Quantities		2	2
	Dimension(Dia.×H)	mm	700*202	700*202
	Vane Quantities		3	3
Outdoor coil	Number of rows		2	2
	Tube pitch(a)x row pitch(b)	mm	22×19	22×19
	Fin spacing	mm	1.6	1.6

			Hydrophilic aluminum	Hydrophilic aluminum
	Fin type (code)			
	Tube outside dia.	mm	Φ7.94	Φ7.94
	Tube type		Inner-grooved	Inner-grooved
	Coil length x height	mm	1864*1232* 2	1864*1232* 2
	Number of circuits		22	22
Outdoor air flow		m ³ /h	23000	23000
External static pressure		Pa	0~20 (default) 20~81.8 (optional)	0~20 (default) 20~81.8 (optional)
Outdoor sound level (*3)		dB(A)	63	63
Outdoor unit	Dimension(W*H*D)	mm	1960*1615*765	1960*1615*765
	Packing (W*H*D)	mm	2025*1815*830	2025*1815*830
	Net/Gross weight	Kg	460/485	460/485
Charged refrigerant type and volume		kg	R410A 18kg	R410A 18kg
Throttle type			EXV	EXV
Excessive operating pressure		MPa	4.4/2.6	4.4/2.6
Refrigerant piping	Liquid side/ Gas side	mm	Φ15.9/Φ31.8	Φ15.9/Φ31.8
	Oil balance pipe	mm	-	-
	Total pipe length(<30HP)	m	350	350
	The farthest pipe length(actual)	m	150	150
	The farthest pipe length (equivalent)	m	175	175
	The farthest equivalent pipe length from the 1st distributor	m	40	40
	Max. Vertical pipe length (When outdoor units is top)	m	70*	70*
	Max. Vertical pipe length (When outdoor units is bottom)	m	70	70
Max. drop between indoor units	m	15	15	
Connection wiring	Power wiring	mm ²	4×16+16(L≤20m); 4×25+16(L≤50m)	4×16+16(L≤20m); 4×25+16(L≤50m)
	Signal wiring	mm ²	3 core shielded wiring; wiring dia.≥0.75	3 core shielded wiring; wiring dia.≥0.75
Ambient temp. range - Cooling		°C	-5°C—48°C	-5°C—48°C
Ambient temp. range - Heating		°C	-20°C—21°C	-20°C—21°C

Notes:

- The cooling conditions: indoor temp.: 27°CDB(80.6°F), 19°CWB(60°F) outdoor temp.: 35°CDB(95°F) equivalent pipe length: 5m drop length: 0m.
 - The heating conditions: indoor temp.: 20°CDB(68°F), 15°CWB(44.6°F) outdoor temp.: 7°CDB(42.8°F) equivalent pipe length: 5m drop length: 0m.
 - Sound level: Anechoic chamber conversion value, measured at a point 1 m in front of the unit at a height of 1.5 m. During actual operation, these values are normally somewhat higher as a result of ambient conditions.
 - It's the dimension of connecting pipes between outdoor and first branch joint when the Max. Equivalent length of tubing is less than 90m.
 - The above data may be changed without notice for future improvement on quality and performance.
- * Level difference above 50m are not supported by default but are available on request for customized.

Model		MDV-850W/DRN1-i(B)
Power supply	V-Ph-Hz	380~415V 3Ph ~ 50Hz

Cooling (*1)	Capacity	W	85000
	Input	W	26600
	EER	W/W	3.2
	IPLV	W/W	1.98
Heating (*2)	Capacity	W	95000
	Input	W	24400
	COP	W/W	3.9
Max. input consumption		W	38390
Max. current		A	62.5
DC Inv. compressor	Model		E405DHD-36D2YG
	Quantities		1
	Type		DC Inv
	Brand		Hitachi
	Capacity	Btu/h	11800
	Input	W	3665
	Power supply	V-Ph-Hz	380-415V~3Ph, 50Hz
	Operating frequency	Hz	48~230
	Crankcase	W	33
	Refrigerant oil	ml	FVC68D / 500
Fixed scroll compressor	Model		E655DH-65D2YG(GC)
	Quantities		5
	Type		Fixed scroll
	Brand		Hitachi
	Capacity	Btu/h	17100×5
	Input	W	5740×5
	Power supply	V-Ph-Hz	380-415V~3Ph, 50Hz
	Locked rotor ampere (LRA)	A	68×5
	Thermal protector type		Inner
	Crankcase	W	33×5
	Refrigerant oil	ml	FVC68D / 500×5
Outdoor fan motor	Model		WZDK750-38G-5
	Type		DC Inverter
	Brand		Panasonic
	Quantities		2
	Insulation class		E
	Safe class		IPX4
	Input	W	474×2
	Output	W	750×2
	Capacitor		20 uF
	Rated current	A	5.82×2
	Speed	r/min	975
Outdoor fan	material		Plastic
	Type		Axial
	Fan Quantities		2+2
	Dimension(Dia.×H)	mm	Φ560*189/Φ562*162
	Vane Quantities		3/4
Outdoor coil	Number of rows		2
	Tube pitch(a)× row pitch(b)	mm	22×19
	Fin spacing	mm	1.6
	Fin type (code)		Hydrophilic aluminum
	Tube outside dia.	mm	Φ7.94
	Tube type		Inner-grooved
	Coil length x height	mm	2141*1232

	Number of circuits		22
Outdoor air flow		m ³ /h	27900
External static pressure		Pa	0~20 (default) 20~81.8 (optional)
Outdoor sound level (*3)		dB(A)	64
Outdoor unit	Dimension(W*H*D)	mm	2540*1615*765
	Packing (W*H*D)	mm	2600*1800*825
	Net/Gross weight	Kg	655/690
Charged refrigerant type and volume		kg	R410A 21kg
Throttle type			EXV
Excessive operating pressure		MPa	4.4/2.6
Refrigerant piping	Liquid side/ Gas side	mm	Φ22/Φ38
	Oil balance pipe	mm	
	Total pipe length(≥30HP)	m	500
	The farthest pipe length(actual)	m	150
	The farthest pipe length (equivalent)	m	175
	The farthest equivalent pipe length from the 1st distributor	m	40
	Max. Vertical pipe length (When outdoor units is top)	m	70*
	Max. Vertical pipe length (When outdoor units is bottom)	m	70
	Max. drop between indoor units	m	15
Connection wiring	Power wiring	mm ²	4×35+16(L≤20m); 4×50+16(L≤50m)
	Signal wiring	mm ²	3 core shielded wiring; wiring dia.≥0.75
Ambient temp. range - Cooling		℃	-5℃—48℃
Ambient temp. range - Heating		℃	-20℃—27℃

Notes:

1. The cooling conditions: indoor temp.: 27°CDB(80.6°F), 19°CWB(60°F) outdoor temp.: 35°CDB(95°F) equivalent pipe length: 5m drop length: 0m.
 2. The heating conditions: indoor temp.: 20°CDB(68°F), 15°CWB(44.6°F) outdoor temp.: 7°CDB(42.8°F) equivalent pipe length: 5m drop length: 0m.
 3. Sound level: Anechoic chamber conversion value, measured at a point 1 m in front of the unit at a height of 1.5 m. During actual operation, these values are normally somewhat higher as a result of ambient conditions.
 4. It's the dimension of connecting pipes between outdoor and first branch joint when the Max. Equivalent length of tubing is less than 90m.
 5. The above data may be changed without notice for future improvement on quality and performance.
- * Level difference above 50m is not supported by default but is available on request for customized.

2. Dimensions
2.3 18HP/20HP Dimensions:

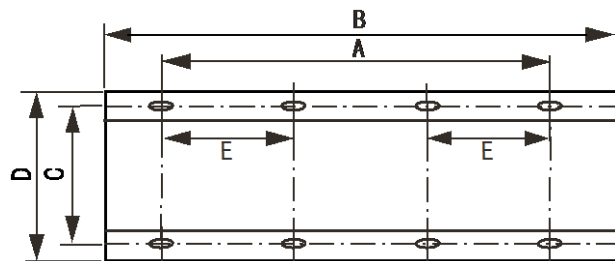
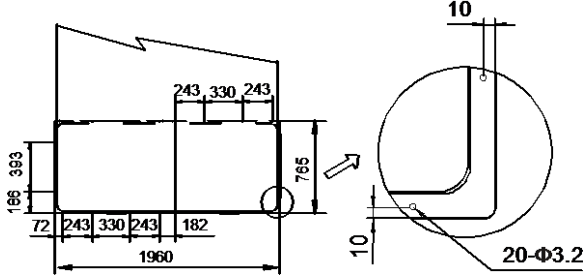
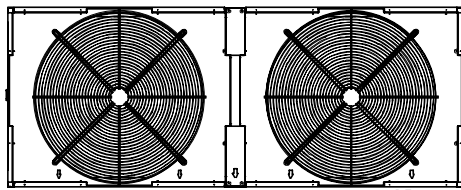
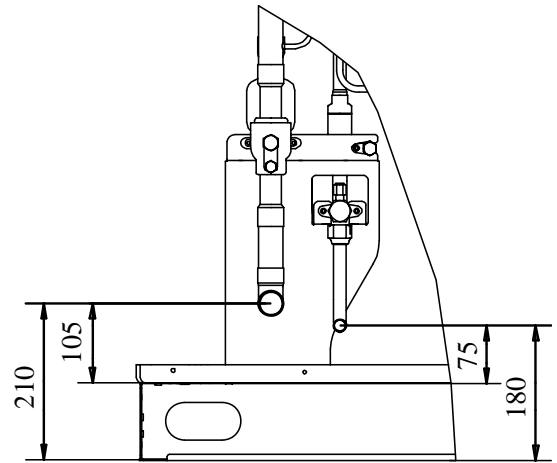
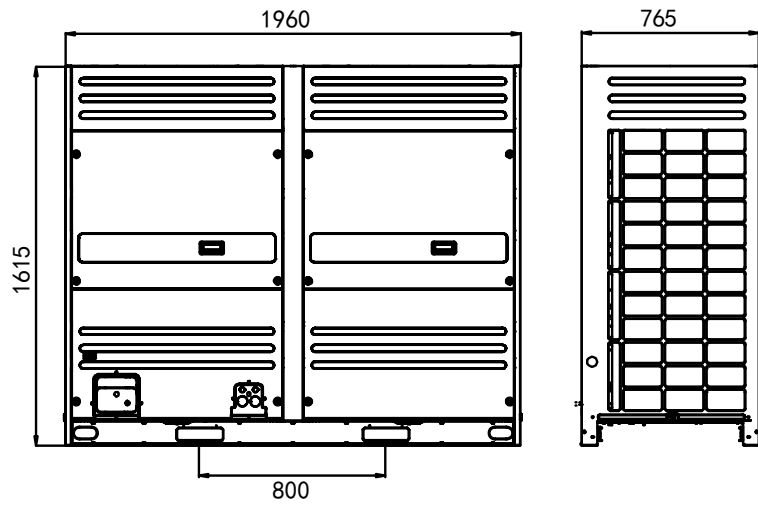

SIZE \ HP	18, 20
A	1830
B	1960
C	736
D	765
E	830

2.4 30HP Dimensions:

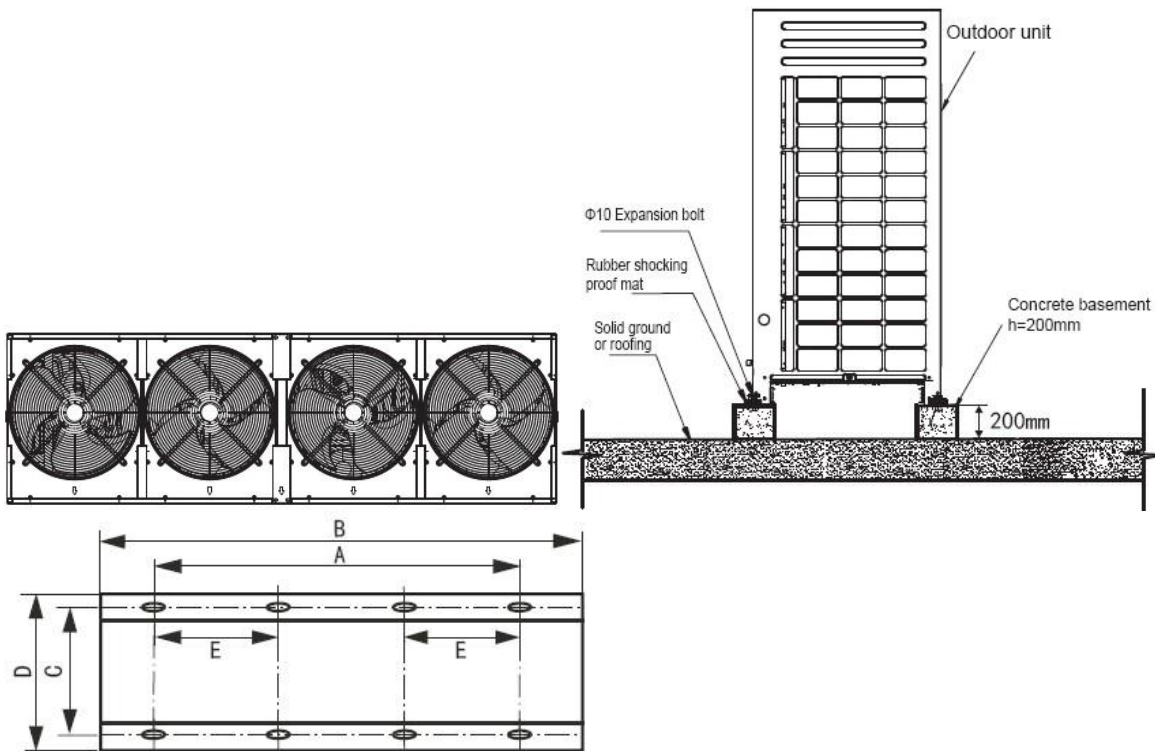
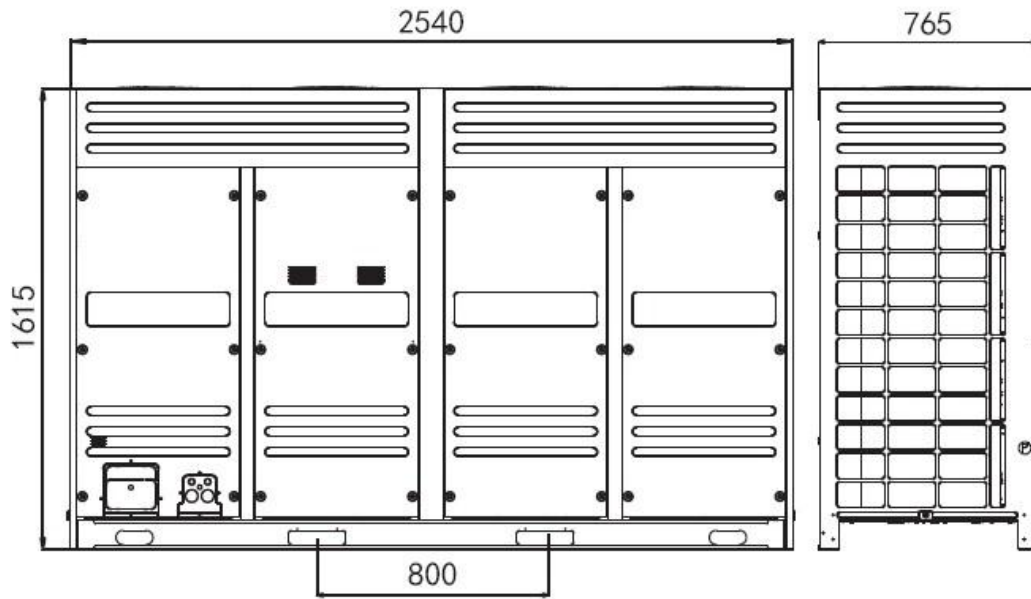

HP	30
A	2410
B	2540
C	736
D	765
E	950

2.5 Valve explanation

18,20HP

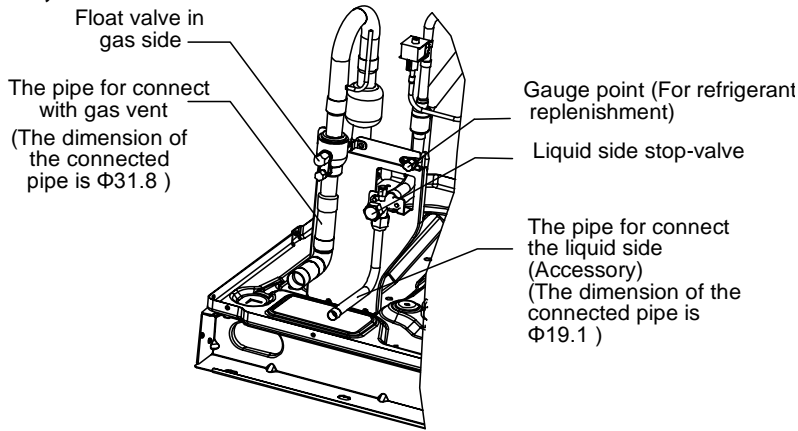

30HP

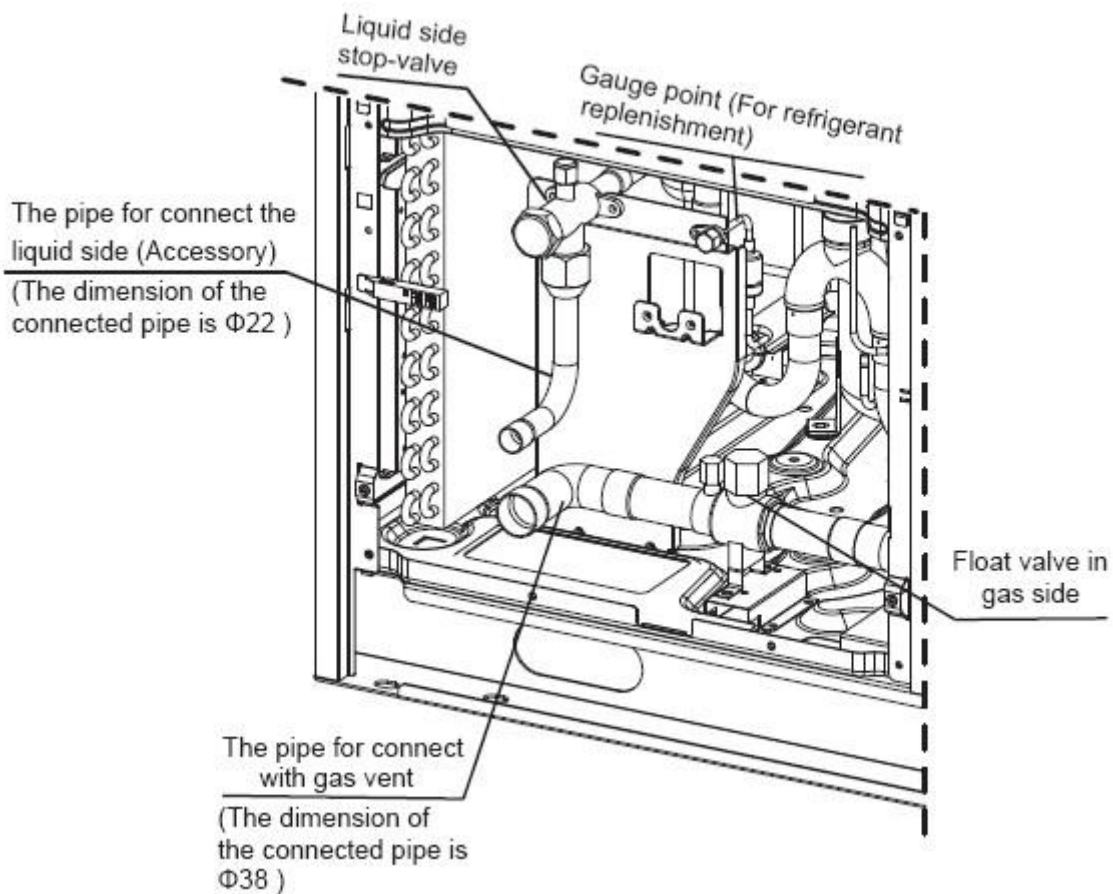

3. Piping Diagrams

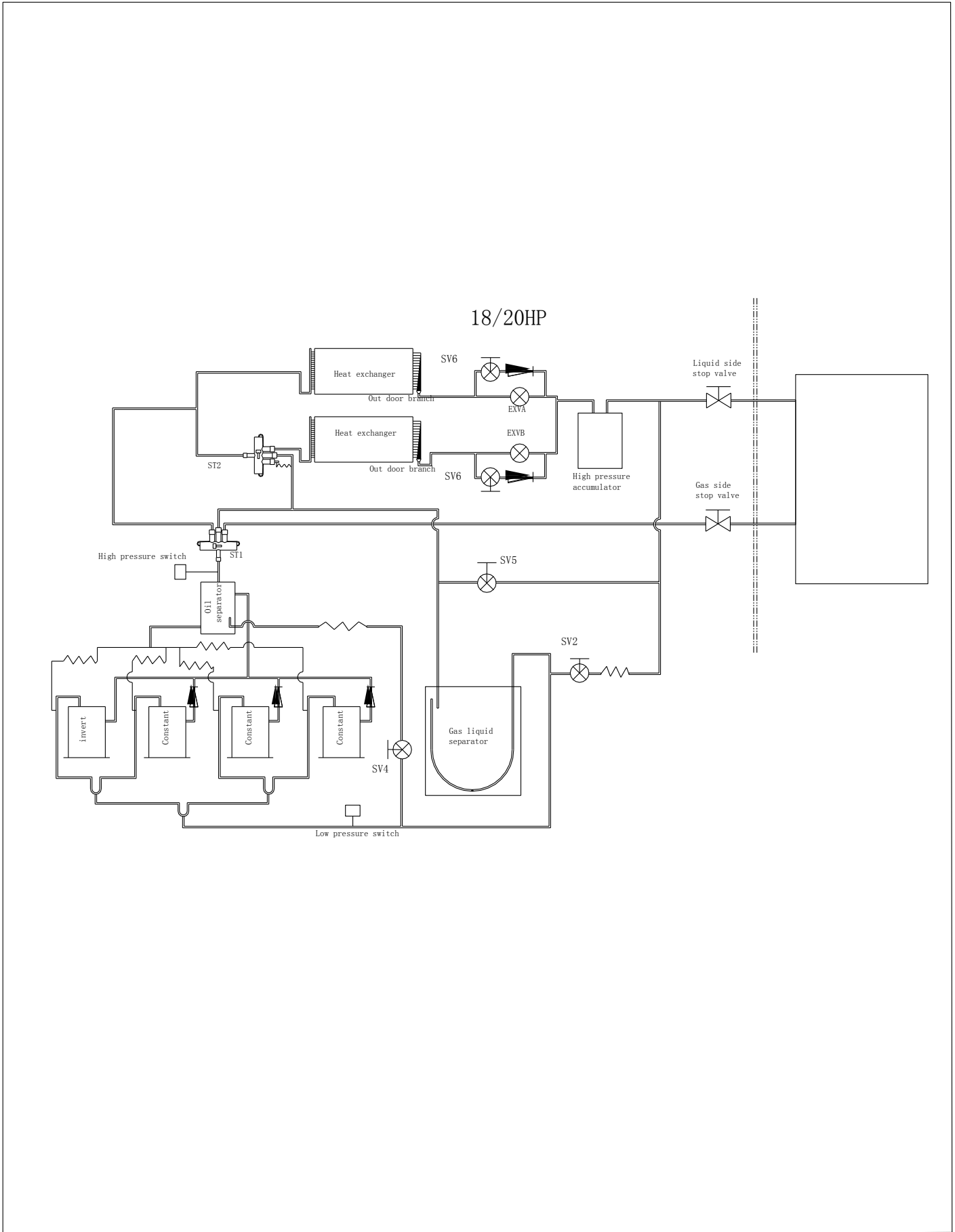

For 30HP

Capacity Tables

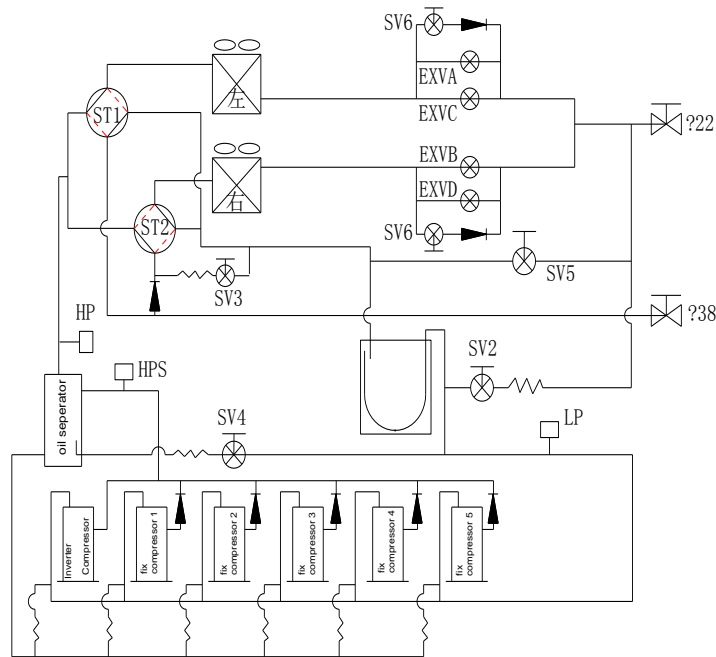

Key Components:

Oil Separator: It is used to separate oil from high pressure & temperature gas refrigerant that is pumped out from compressor. The separation efficiency is up to 99%, it makes the oil return back to each compressor very soon.

Liquid accumulator: It is used to store the overmuch liquid refrigerant, and guarantee the refrigerant from the outdoor to indoor unit is in liquid status.

Gas-liquid separator: It is used to store the liquid refrigerant and oil, it can protect the compressor from liquid hammer.

Four-way valve control (ST1): Closes in cooling mode and opens in heating mode

EXV (electromagnetic expansion valve) control:

- 1) Max. Open degree is 480 pulses.
- 2) Generally when system is electrified the EXV closes 700pulse first, then opens to 350 pulse and stand by. Then the unit is started, it opens to the right pulse.
- 3) When the running outdoor unit receives OFF signal, the EXV of auxiliary unit will stop while main unit is running and auxiliary unit is stopped at the same time. If all outdoor units are stopped, the EXV will close first, and then open to the pulse of stand-by.
- 4) 8HP/10HP/12HP V4+ has one EXV; 14/16/18/20HP V4+ has double EXVs, 30HP V4+ has four EXVs.

SV2: for spraying a little liquid refrigerant to cool compressor down. Open when any compressor discharge temperature is higher than 100°C

SV4: oil returning valve. Opens after the DC inverter compressor has been run for 5 minutes and then closes 15 minutes later. (For the system has only one outdoor unit).

Every 20 minutes, SV4 of each outdoor unit opens for 3 minutes. (For the system has more than one outdoor unit)

SV5: for defrosting. In defrosting mode, the opening of SV5 can cut the refrigerant flowing circle, so the defrosting process will takes less time. In cooling mode, it is always off.

SV6: for by-pass. Closes when the unit stands by and system in heating mode. Open when the discharge

temperature is over-high in cooling mode, and close when the unit is standby or system is in heating mode.

High pressure sensor: To supervisor the discharge pressure of the compressor and to control the DC fan speed.

4. Electric Characteristics

Model	Outdoor Unit				Power Supply			Compressor		OFM	
	Hz	Voltage	Min.	Max.	MCA	TOCA	MFA	MSC	RLA	KW	FLA
MDVi -530W/DRN1-i(B)	50	380~415	342	440	12	43	40	--/65×3	9+8x3	0.77×2	3.42×2
MDVi -560W/DRN1-i(B)	50	380~415	342	440	12.5	43	40	--/68×3	9x4	0.77×2	3.42×2
MDVi -850W/DRN1-i(B)	50	380~415	342	440	75	72	80	--/68×5	6+9.6 x5	2.3	13.88

Remark:

MCA: Min. Current Amps. (A)

TOCA: Total Over-current Amps. (A)

MFA: Max. Fuse Amps. (A)

MSC: Max. Starting Amps. (A)

RLA: Rated Locked Amps. (A)

OFM: Outdoor Fan Motor.

FLA: Full Load Amps. (A)

KW: Rated Motor Output (KW)

Notes:

1. RLA is based on the following conditions, Indoor temp. 27°C DB/19°C WB, Outdoor temp. 35°C DB
2. TOCA means the total value of each OC set.
3. MSC means the Max. current during the starting of compressor.
4. Voltage range. Units are suitable for use on electrical systems where voltage supplied to unit terminals is not below or above listed range limits.
5. Maximum allowable voltage variation between phases is 2%
6. Selection wire size based on the larger value of MCA or TOCA
7. MFA is used to select the circuit breaker and the ground fault circuit interrupter (earth circuit breaker).

5. Wiring Diagrams and Field Wiring

5.2 Wiring Diagram For 18/20HP

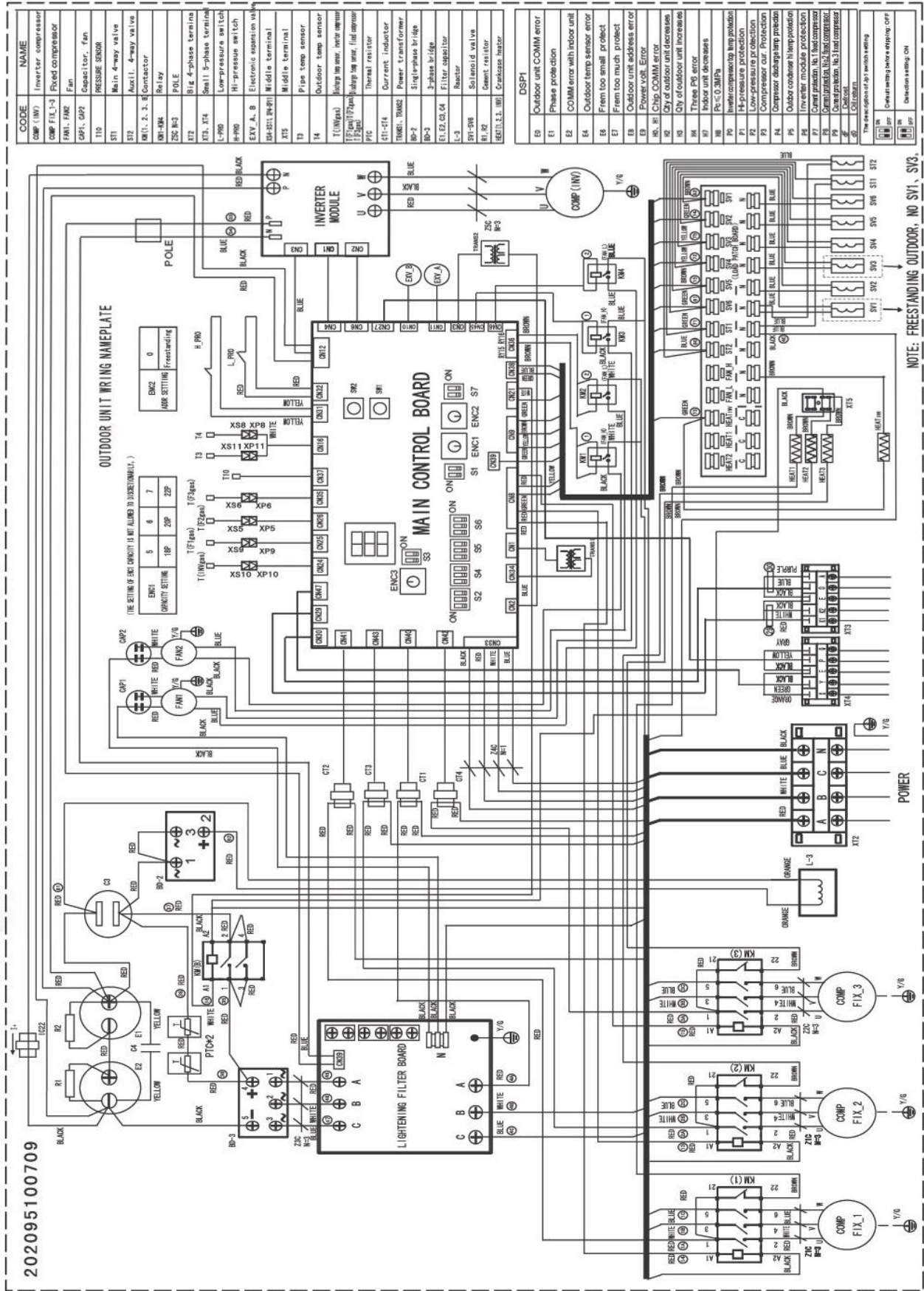

5.3 Wiring Diagram For 30HP

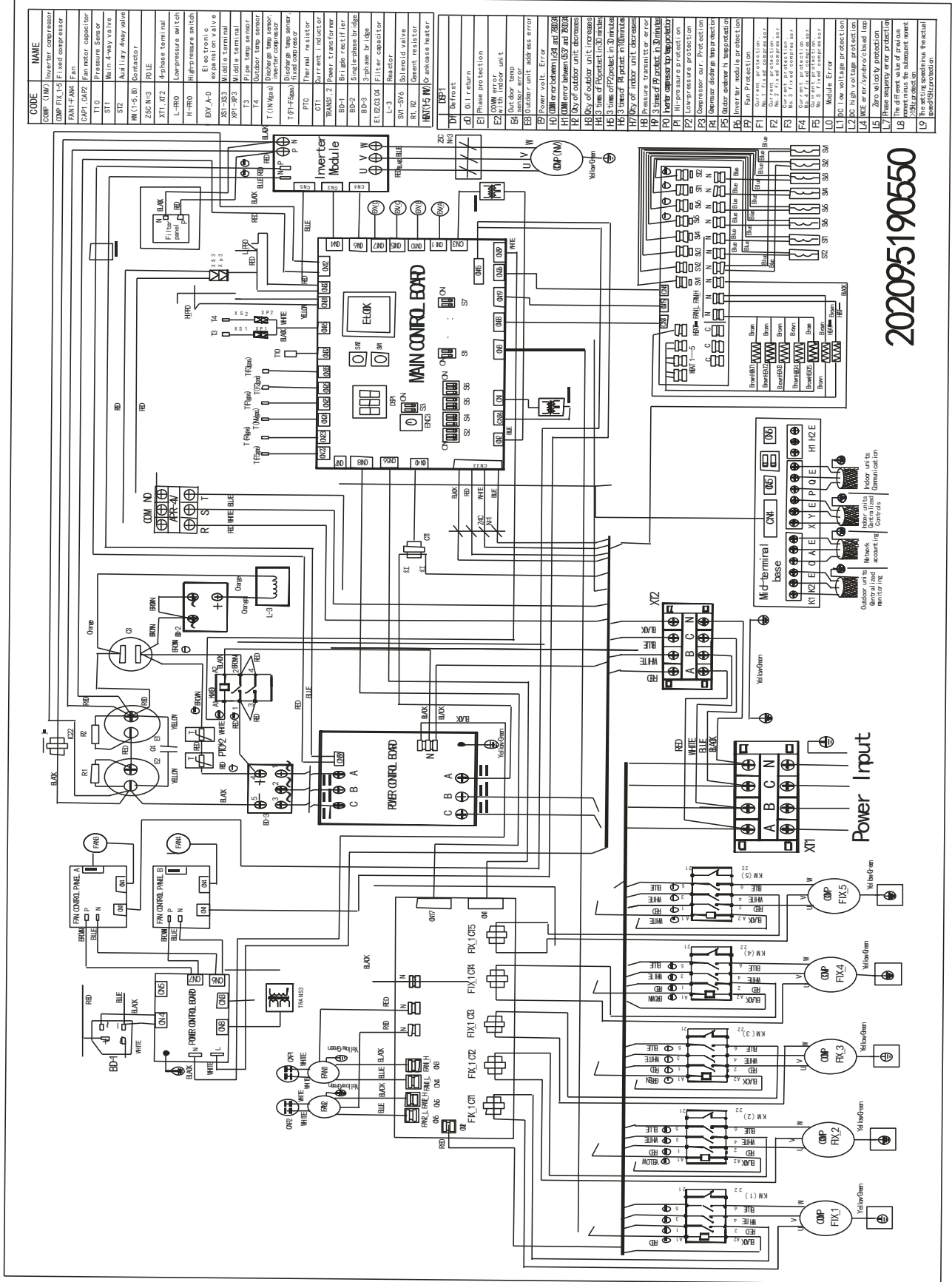

202095190550

5.4 Field Wiring

a) Terminal of Outdoor unit

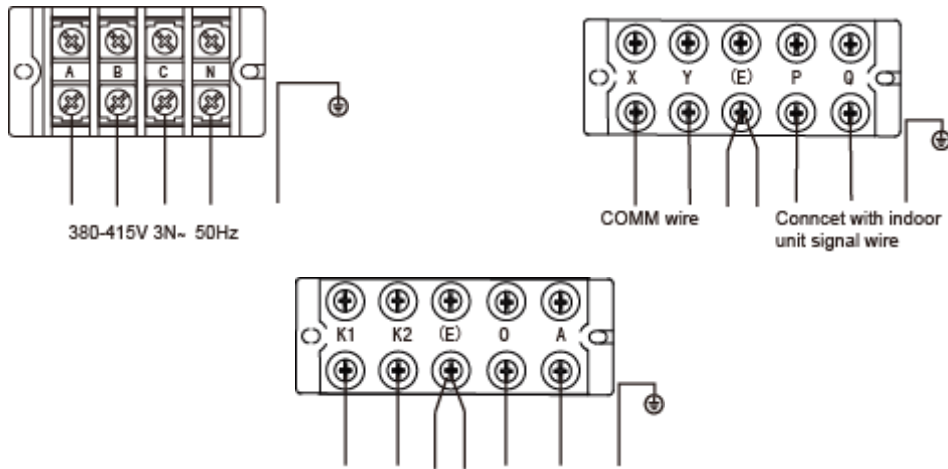

The special wire joint for Network Fee counting system

b) Wiring between Indoor and Outdoor unit

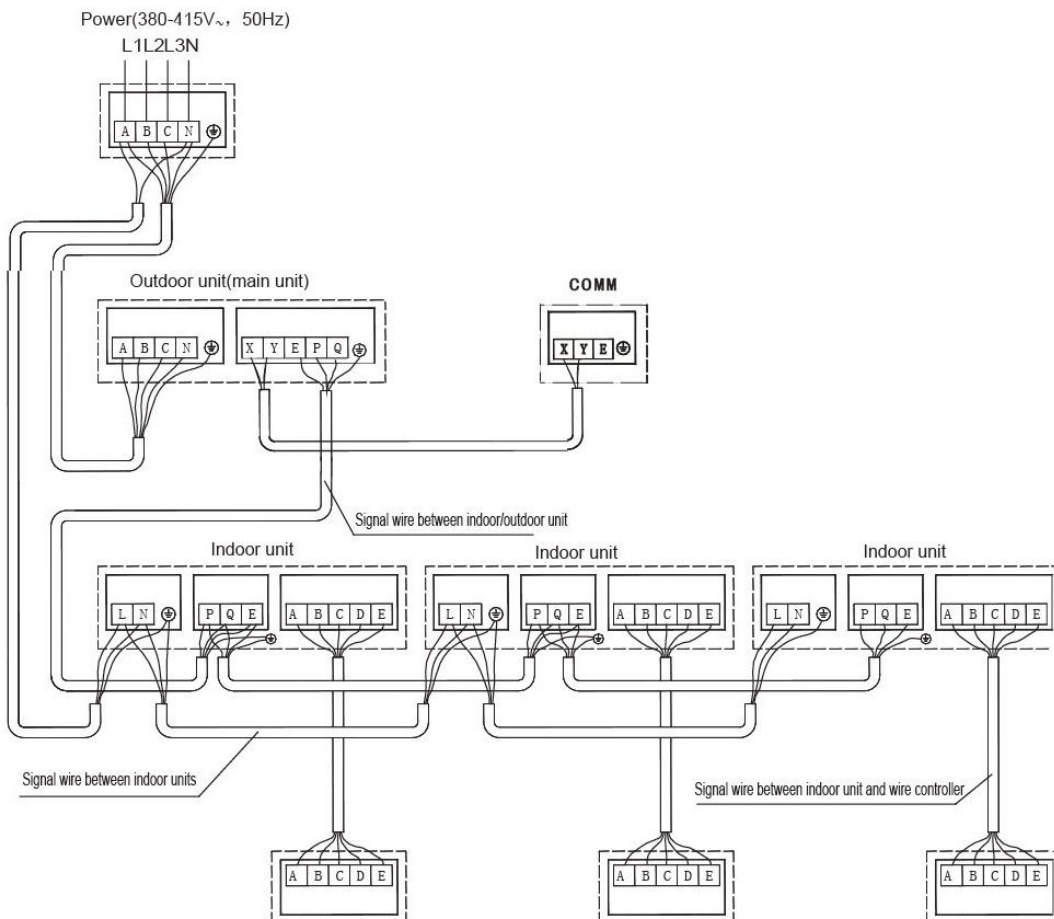

Note:

1. The signal connecting line between indoor and outdoor units and indoor units has polarity. When connecting, be careful to prevent error connection.

2. Signal line shall adopt three-core shielded wire with an area above 0.75 mm².
3. Do not bind signal line and copper pipe together with belting.
4. Make sure that the shield metal layer should be grounded well indoor control box in order to prevent interference.
5. it's forbidden to connect 200V or above high-volt live wire to the communication terminal.

5.5 Outdoor unit power wiring

5.3.1 Separate Power Supply (without power facility).m²

Model	Power	The shortest wiring dia. (mm)			Manual switch (A)		Creepage protector
		≤20m	≤50m	GND	Capacity	Fuse	
	380~415V 3N ~ 50Hz						
MDVi-530W/DRN1 -i(B)		4×16	4×25	16	80	70	<100mA, 0.1sec
MDVi-560W/DRN1 -i(B)		4×25	4×35	16	80	70	<100mA, 0.1sec
MDVi-850W/DRN1-i(B)		4×35	4×50	16	100	80	<100mA, 0.1sec

5.3.2 With power facilities:

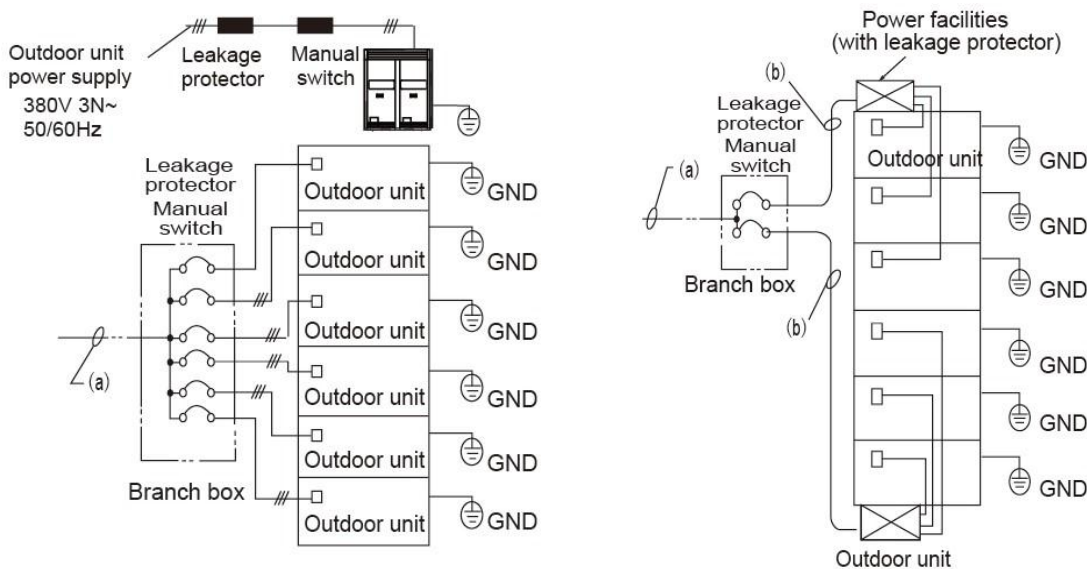

Note:

- 1, Select power cord for these models separately according to relevant standard. 8HP, 10HP, 12HP, 14HP, 16HP, 18HP, 20HP and 30HP.
 - 2, The wiring diameter and the length in the table indicate the condition that the voltage dropping range is within 2%. If the length exceeds the above figure, please select the wire diameter according to relevant standard.
 - 3, Select the wire diameter
- Power wiring refers to the main wire (a) connecting to branch box and the wiring (b) between branch box and power facilities. Please select the wire diameter according to the following requirement.
- 4, Diameter of main wire (a)
Depends on the horsepower of outdoor unit and following table.
 - 5, Wiring(b):between branch box and power equipment. Depends on the number of combined outdoor unit. If fewer than 5, the diameter is the same as that of main wire (a); if more than 6, there will be 2 electric control boxes, and the diameter of wiring depends on the total horsepower of outdoor units connecting to each electric control box and following table.

5.3.3 Reference table of the cable size for each capacity

Total capacity (HP)	Min. Diameter of wiring (mm ²) from weather proof isolator to ODU
---------------------	--

	Below 20 m	20 to 50 m
8	10	16
10	10	16
12	10	16
14	16	25
16	16	25
18	16	25
20	25	35
30	35	50

Remark: The above selection is just for reference, it should be considered that the cable layout, space between cable and surroundings, etc. for an actual electrical project

6. Operation Limits

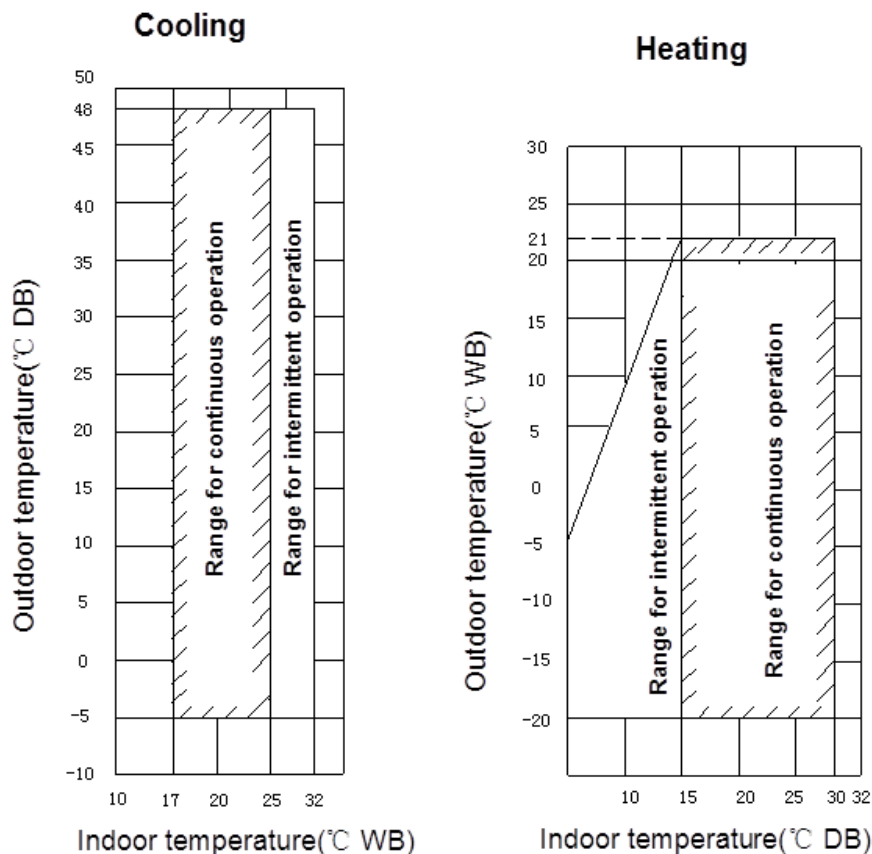

	Outdoor temp.	Indoor temp.	Room relative humidity
Cooling mode	-5°C ~ 48°C	17°C ~ 32°C	below 80%
Heating mode	-20°C ~ 21°C	15°C ~ 30°C	—

Notes:

1. If the unit is running outside the above condition, protective device will start, and even then the units take place abnormality running.
2. These figures base on the operation conditions between indoor units and outdoor units: Equivalent pipe length is 5m, and height difference is 0m.

Precaution:

The indoor relative humidity should be lower than 80%. If the air conditioner works in an environment with a relative humidity higher than mentioned above, the surface of the air conditioner may condensate. In this case, it is recommended to set the air speed of the indoor unit to high.

7. Capacity Tables

18HP Cooling mode

Combination (%) (Capacity index)	Outdoor temperature (°C DB)	Indoor temperature(°C WB)													
		DB:20.8,WB:14		DB:23.3,WB:16		DB:25.8,WB:18		DB:27,WB:19		DB:28.2,WB:20		DB:30.7,WB:22		DB:32,WB:24	
		TC	PI	TC	PI	TC	PI	TC	PI	TC	PI	TC	PI	TC	PI
		kW	kW	kW	kW	kW	kW	kW	kW	kW	kW	kW	kW	kW	kW
130%	10	46.56	7.38	55.46	9.01	64.35	10.72	66.82	10.96	67.57	10.74	69.28	10.29	70.98	9.81
	12	46.56	7.50	55.46	9.19	64.35	10.93	65.87	10.89	66.82	10.67	68.33	10.20	70.03	10.05
	14	46.56	7.66	55.46	9.36	64.17	11.06	65.11	10.93	65.87	10.61	67.57	10.52	69.28	10.63
	16	46.56	7.79	55.46	9.55	63.41	11.02	64.17	10.85	64.92	10.98	66.63	11.08	68.33	11.19
	18	46.56	7.94	55.46	9.75	62.46	11.43	63.22	11.49	64.17	11.56	65.87	11.67	67.57	11.78
	20	46.56	8.11	55.46	10.37	61.52	11.99	62.46	12.05	63.22	12.12	64.92	12.23	66.63	12.36
	21	46.56	8.32	55.46	10.74	61.14	12.27	62.08	12.34	62.84	12.40	64.54	12.53	66.25	12.64
	23	46.56	8.93	55.46	11.52	60.38	12.83	61.14	12.89	61.89	12.96	63.60	13.09	65.30	13.22
	25	46.56	9.53	55.46	12.34	59.43	13.39	60.19	13.46	61.14	13.54	62.84	13.67	64.54	13.80
	27	46.56	10.18	55.46	13.20	58.68	13.95	59.43	14.04	60.19	14.10	61.89	14.25	63.60	14.41
	29	46.56	10.87	55.46	14.10	57.73	14.51	58.49	14.60	59.43	14.69	61.14	14.84	62.84	14.99
	31	46.56	11.60	55.27	14.92	56.78	15.10	57.73	15.18	58.49	15.25	60.19	15.42	61.89	15.59
	33	46.56	12.36	54.32	15.48	56.03	15.66	56.78	15.74	57.73	15.83	59.43	16.00	60.95	16.17
	35	46.56	13.18	53.38	16.04	55.08	16.24	56.03	16.32	56.78	16.41	58.49	16.61	60.19	16.78
	37	46.56	14.02	52.62	16.63	54.32	16.82	55.08	16.91	56.03	17.02	57.54	17.21	59.24	17.40
	39	46.56	14.92	51.67	16.80	53.38	17.38	54.32	17.49	55.08	17.60	56.78	17.79	58.49	18.01
42	46.56	15.71	51.14	16.96	52.82	17.54	53.76	17.65	54.52	17.76	56.22	17.83	56.24	18.17	
44	46.56	16.50	50.61	17.13	52.26	17.64	53.20	17.82	53.40	17.81	54.18	17.89	54.91	18.25	
46	46.56	17.31	50.39	17.29	51.70	17.87	52.64	17.88	52.95	17.92	53.22	17.96	54.07	18.86	
120%	10	42.97	6.73	51.10	8.22	59.44	9.77	63.60	10.57	66.63	11.02	68.14	10.59	69.66	10.18
	12	42.97	6.86	51.10	8.37	59.44	9.96	63.60	10.76	65.68	10.95	67.19	10.55	68.71	10.11
	14	42.97	6.99	51.10	8.54	59.44	10.16	63.60	10.98	64.73	10.89	66.44	10.48	67.95	10.55
	16	42.97	7.12	51.10	8.71	59.44	10.35	63.22	11.06	63.98	10.91	65.49	11.02	67.01	11.10
	18	42.97	7.25	51.10	8.88	59.44	10.70	62.28	11.43	63.03	11.47	64.55	11.58	66.25	11.69
	20	42.97	7.40	51.10	9.23	59.44	11.51	61.52	11.99	62.28	12.03	63.79	12.14	65.31	12.25
	21	42.97	7.46	51.10	9.55	59.44	11.93	60.95	12.27	61.70	12.31	63.41	12.42	64.93	12.55
	23	42.97	7.98	51.10	10.24	59.44	12.77	60.19	12.81	60.95	12.87	62.46	13.00	63.98	13.11
	25	42.97	8.52	51.10	10.95	58.49	13.33	59.25	13.37	60.00	13.43	61.70	13.56	63.22	13.69
	27	42.97	9.10	51.10	11.71	57.73	13.87	58.49	13.95	59.25	14.02	60.76	14.15	62.28	14.27
	29	42.97	9.70	51.10	12.51	56.79	14.43	57.54	14.51	58.30	14.58	59.82	14.73	61.52	14.86
	31	42.97	10.35	51.10	13.35	55.84	15.01	56.79	15.07	57.54	15.16	59.06	15.31	60.57	15.46
	33	42.97	11.02	51.10	14.23	55.08	15.57	55.84	15.65	56.59	15.72	58.11	15.89	59.62	16.04
	35	42.97	11.73	51.10	15.18	54.13	16.13	54.89	16.22	55.84	16.30	57.35	16.48	58.87	16.65
	37	42.97	12.48	51.10	16.17	53.38	16.71	54.13	16.80	54.89	16.88	56.41	17.06	57.92	17.25
	39	42.97	13.28	50.92	17.08	52.43	17.27	53.19	17.38	53.95	17.47	55.65	17.66	57.16	17.83
42	42.97	13.77	50.37	17.24	51.88	17.44	52.64	17.54	53.40	17.63	55.10	17.73	54.97	18.01	
44	42.97	13.93	50.10	17.40	51.34	17.57	52.09	17.59	52.85	17.68	53.45	17.79	54.35	18.64	
46	42.97	14.09	49.82	17.57	50.90	17.76	51.54	17.87	52.47	17.90	52.91	17.84	53.87	18.81	
110%	10	39.37	6.10	46.95	7.44	54.52	8.84	58.30	9.55	62.08	10.29	66.82	10.91	68.34	10.54
	12	39.37	6.23	46.95	7.59	54.52	9.01	58.30	9.75	62.08	10.48	66.07	10.87	67.39	10.48
	14	39.37	6.34	46.95	7.72	54.52	9.19	58.30	9.92	62.08	10.68	65.12	10.80	66.63	10.46
	16	39.37	6.45	46.95	7.87	54.52	9.36	58.30	10.11	62.08	10.89	64.36	10.93	65.68	11.04
	18	39.37	6.58	46.95	8.02	54.52	9.55	58.30	10.39	62.08	11.41	63.41	11.49	64.93	11.60
	20	39.37	6.71	46.95	8.19	54.52	10.11	58.30	11.17	61.14	11.97	62.66	12.05	63.98	12.16
	21	39.37	6.77	46.95	8.43	54.52	10.48	58.30	11.58	60.76	12.25	62.09	12.33	63.60	12.44
	23	39.37	7.09	46.95	9.04	54.52	11.24	58.30	12.42	59.82	12.79	61.33	12.91	62.66	13.03
	25	39.37	7.57	46.95	9.66	54.52	12.01	58.30	13.31	59.06	13.35	60.38	13.48	61.90	13.59
	27	39.37	8.07	46.95	10.33	54.52	12.85	57.36	13.87	58.11	13.91	59.63	14.04	60.95	14.17
	29	39.37	8.60	46.95	11.02	54.52	13.74	56.60	14.43	57.36	14.49	58.68	14.62	60.20	14.75
	31	39.37	9.16	46.95	11.75	54.52	14.66	55.65	14.99	56.41	15.05	57.92	15.18	59.25	15.33
	33	39.37	9.75	46.95	12.53	54.14	15.46	54.89	15.55	55.65	15.61	56.98	15.76	58.49	15.92
	35	39.37	10.37	46.95	13.35	53.19	16.02	53.95	16.11	54.70	16.20	56.03	16.35	57.55	16.50
	37	39.37	11.04	46.95	14.21	52.43	16.60	53.19	16.67	53.76	16.76	55.28	16.93	56.60	17.08
	39	39.37	11.73	46.95	15.14	51.49	17.17	52.24	17.25	53.00	17.34	54.33	17.51	55.84	17.68
42	39.37	11.89	46.95	15.30	50.95	17.33	51.70	17.41	52.47	17.50	53.41	17.67	53.60	17.84	
44	39.37	12.05	46.95	15.46	50.41	17.49	51.16	17.57	51.93	17.66	52.91	17.72	53.06	18.49	
46	39.37	12.36	46.95	15.62	49.92	17.65	50.63	17.83	51.53	17.82	52.33	18.64	52.61	18.69	
100%	10	35.78	5.52	42.59	6.68	49.59	7.91	53.00	8.56	56.41	9.21	63.41	10.52	67.01	10.89

	12	35.78	5.61	42.59	6.81	49.59	8.06	53.00	8.71	56.41	9.38	63.41	10.72	66.06	10.82
	14	35.78	5.71	42.59	6.94	49.59	8.22	53.00	8.88	56.41	9.55	63.41	10.93	65.30	10.76
	16	35.78	5.82	42.59	7.07	49.59	8.39	53.00	9.06	56.41	9.75	63.03	11.06	64.36	10.95
	18	35.78	5.93	42.59	7.20	49.59	8.54	53.00	9.23	56.41	9.94	62.28	11.43	63.60	11.52
	20	35.78	6.04	42.59	7.35	49.59	8.80	53.00	9.70	56.41	10.65	61.33	11.97	62.65	12.08
	21	35.78	6.10	42.59	7.42	49.59	9.12	53.00	10.05	56.41	11.02	60.95	12.25	62.28	12.36
	23	35.78	6.25	42.59	7.91	49.59	9.77	53.00	10.76	56.41	11.82	60.19	12.81	61.33	12.92
	25	35.78	6.66	42.59	8.45	49.59	10.46	53.00	11.54	56.41	12.66	59.25	13.37	60.57	13.48
	27	35.78	7.12	42.59	9.01	49.59	11.17	53.00	12.33	56.41	13.54	58.30	13.93	59.63	14.06
	29	35.78	7.57	42.59	9.62	49.59	11.92	53.00	13.18	56.22	14.38	57.54	14.51	58.87	14.62
	31	35.78	8.06	42.59	10.26	49.59	12.72	53.00	14.06	55.46	14.94	56.60	15.07	57.92	15.20
	33	35.78	8.56	42.59	10.93	49.59	13.56	53.00	15.01	54.52	15.50	55.84	15.63	57.17	15.78
	35	35.78	9.10	42.59	11.62	49.59	14.47	53.00	16.00	53.57	16.06	54.89	16.21	56.22	16.35
	37	35.78	9.68	42.59	12.38	49.59	15.42	52.05	16.56	52.81	16.65	54.13	16.80	55.27	16.93
	39	35.78	10.28	42.59	13.15	49.59	16.41	51.29	17.12	51.86	17.21	53.19	17.36	54.52	17.53
	42	35.78	10.92	42.59	13.79	49.59	17.21	50.23	17.28	51.33	17.56	51.96	17.77	53.46	18.01
	44	35.78	11.56	42.59	14.43	49.59	17.44	49.17	17.60	50.85	17.72	53.19	18.00	52.09	18.17
	46	35.78	12.20	42.59	15.07	49.59	17.80	48.11	17.76	50.80	18.20	51.07	18.32	51.34	18.49
90%	10	32.18	4.94	38.43	5.95	44.67	7.03	47.70	7.59	50.73	8.15	56.97	9.31	63.22	10.50
	12	32.18	5.02	38.43	6.06	44.67	7.16	47.70	7.72	50.73	8.30	56.97	9.49	63.22	10.69
	14	32.18	5.11	38.43	6.17	44.67	7.29	47.70	7.87	50.73	8.45	56.97	9.66	63.22	10.89
	16	32.18	5.20	38.43	6.27	44.67	7.44	47.70	8.02	50.73	8.62	56.97	9.85	63.03	11.08
	18	32.18	5.28	38.43	6.40	44.67	7.57	47.70	8.17	50.73	8.80	56.97	10.05	62.28	11.43
	20	32.18	5.39	38.43	6.55	44.67	7.72	47.70	8.34	50.73	9.12	56.97	10.80	61.33	11.97
	21	32.18	5.43	38.43	6.60	44.67	7.85	47.70	8.62	50.73	9.44	56.97	11.19	60.95	12.25
	23	32.18	5.54	38.43	6.86	44.67	8.41	47.70	9.25	50.73	10.13	56.97	12.01	60.00	12.81
	25	32.18	5.84	38.43	7.33	44.67	8.99	47.70	9.90	50.73	10.82	56.97	12.85	59.25	13.37
	27	32.18	6.21	38.43	7.81	44.67	9.60	47.70	10.57	50.73	11.58	56.97	13.76	58.30	13.93
	29	32.18	6.62	38.43	8.32	44.67	10.24	47.70	11.28	50.73	12.38	56.41	14.38	57.54	14.49
	31	32.18	7.03	38.43	8.86	44.67	10.91	47.70	12.03	50.73	13.20	55.46	14.94	56.60	15.07
	33	32.18	7.46	38.43	9.42	44.67	11.64	47.70	12.83	50.73	14.08	54.70	15.52	55.84	15.63
	35	32.18	7.93	38.43	10.03	44.67	12.40	47.70	13.67	50.73	15.01	53.76	16.09	54.89	16.21
37	32.18	8.41	38.43	10.65	44.67	13.20	47.70	14.55	50.73	16.00	52.81	16.65	54.13	16.77	
39	32.18	8.93	38.43	11.34	44.67	14.04	47.70	15.50	50.73	17.03	52.06	17.23	53.19	17.36	
42	32.18	9.34	38.43	12.03	44.67	14.72	47.70	16.05	50.73	17.17	51.57	17.81	52.71	17.90	
44	32.18	10.02	38.43	12.71	44.67	15.40	47.70	16.60	50.73	17.83	51.28	17.98	52.04	18.18	
46	32.18	10.57	38.43	13.26	44.67	15.95	47.70	17.14	50.73	18.14	51.00	18.19	51.11	18.39	
80%	10	28.58	4.38	34.07	5.24	39.56	6.17	42.40	6.64	45.24	7.12	50.73	8.13	56.22	9.16
	12	28.58	4.44	34.07	5.33	39.56	6.27	42.40	6.77	45.24	7.27	50.73	8.28	56.22	9.34
	14	28.58	4.53	34.07	5.43	39.56	6.38	42.40	6.88	45.24	7.40	50.73	8.43	56.22	9.51
	16	28.58	4.59	34.07	5.52	39.56	6.51	42.40	7.01	45.24	7.53	50.73	8.60	56.22	9.68
	18	28.58	4.68	34.07	5.63	39.56	6.64	42.40	7.16	45.24	7.68	50.73	8.78	56.22	9.88
	20	28.58	4.77	34.07	5.74	39.56	6.77	42.40	7.29	45.24	7.83	50.73	9.10	56.22	10.57
	21	28.58	4.81	34.07	5.78	39.56	6.84	42.40	7.37	45.24	8.00	50.73	9.42	56.22	10.95
	23	28.58	4.90	34.07	5.91	39.56	7.16	42.40	7.85	45.24	8.56	50.73	10.09	56.22	11.75
	25	28.58	5.05	34.07	6.27	39.56	7.66	42.40	8.39	45.24	9.14	50.73	10.80	56.22	12.57
	27	28.58	5.37	34.07	6.68	39.56	8.15	42.40	8.95	45.24	9.77	50.73	11.54	56.22	13.46
	29	28.58	5.71	34.07	7.12	39.56	8.69	42.40	9.53	45.24	10.44	50.73	12.31	56.22	14.38
	31	28.58	6.06	34.07	7.57	39.56	9.25	42.40	10.16	45.24	11.13	50.73	13.15	55.27	14.94
	33	28.58	6.45	34.07	8.04	39.56	9.85	42.40	10.83	45.24	11.84	50.73	14.02	54.51	15.50
	35	28.58	6.84	34.07	8.56	39.56	10.48	42.40	11.52	45.24	12.61	50.73	14.94	53.57	16.06
37	28.58	7.25	34.07	9.08	39.56	11.15	42.40	12.27	45.24	13.43	50.73	15.94	52.81	16.63	
39	28.58	7.68	34.07	9.68	39.56	11.86	42.40	13.05	45.24	14.30	50.73	16.97	51.86	17.21	
42	28.58	7.91	34.07	9.80	39.56	12.09	42.40	13.51	45.24	14.64	50.73	17.55	51.44	17.61	
44	28.58	8.25	34.07	9.91	39.56	12.32	42.40	13.74	45.24	14.87	50.73	17.66	51.02	17.78	
46	28.58	8.37	34.07	10.03	39.56	12.56	42.40	14.08	45.24	15.15	50.73	17.93	50.59	18.19	
70%	10	24.99	3.86	29.91	4.57	34.64	5.33	37.10	5.74	39.56	6.15	44.29	6.99	49.21	7.85
	12	24.99	3.90	29.91	4.64	34.64	5.43	37.10	5.84	39.56	6.25	44.29	7.12	49.21	8.00
	14	24.99	3.97	29.91	4.72	34.64	5.52	37.10	5.93	39.56	6.36	44.29	7.25	49.21	8.15
	16	24.99	4.03	29.91	4.81	34.64	5.63	37.10	6.06	39.56	6.49	44.29	7.38	49.21	8.30
	18	24.99	4.10	29.91	4.90	34.64	5.74	37.10	6.17	39.56	6.60	44.29	7.53	49.21	8.47
	20	24.99	4.16	29.91	4.98	34.64	5.84	37.10	6.28	39.56	6.73	44.29	7.68	49.21	8.71
	21	24.99	4.21	29.91	5.02	34.64	5.89	37.10	6.34	39.56	6.79	44.29	7.78	49.21	9.01
	23	24.99	4.27	29.91	5.11	34.64	6.02	37.10	6.56	39.56	7.14	44.29	8.35	49.21	9.66
25	24.99	4.36	29.91	5.33	34.64	6.40	37.10	7.01	39.56	7.61	44.29	8.93	49.21	10.33	

	27	24.99	4.61	29.91	5.67	34.64	6.84	37.10	7.46	39.56	8.13	44.29	9.53	49.21	11.04
	29	24.99	4.90	29.91	6.02	34.64	7.27	37.10	7.96	39.56	8.65	44.29	10.16	49.21	11.80
	31	24.99	5.17	29.91	6.38	34.64	7.74	37.10	8.45	39.56	9.21	44.29	10.82	49.21	12.57
	33	24.99	5.50	29.91	6.79	34.64	8.24	37.10	8.99	39.56	9.81	44.29	11.54	49.21	13.41
	35	24.99	5.82	29.91	7.20	34.64	8.73	37.10	9.57	39.56	10.44	44.29	12.29	49.21	14.30
	37	24.99	6.15	29.91	7.63	34.64	9.29	37.10	10.16	39.56	11.11	44.29	13.09	49.21	15.22
	39	24.99	6.51	29.91	8.09	34.64	9.85	37.10	10.80	39.56	11.80	44.29	13.91	49.21	16.22
	42	24.99	6.90	29.91	8.47	34.64	10.24	37.10	11.28	39.56	12.27	44.29	14.67	49.21	17.17
	44	24.99	7.35	29.91	8.95	34.64	10.56	37.10	11.76	39.56	12.75	44.29	15.34	49.21	17.75
	46	24.99	7.68	29.91	9.33	34.64	11.00	37.10	12.14	39.56	13.14	44.29	15.82	49.21	18.13
60%	10	21.39	3.34	25.55	3.92	29.72	4.55	31.80	4.87	33.88	5.20	38.05	5.89	42.21	6.60
	12	21.39	3.41	25.55	3.99	29.72	4.64	31.80	4.96	33.88	5.28	38.05	5.99	42.21	6.71
	14	21.39	3.45	25.55	4.05	29.72	4.70	31.80	5.05	33.88	5.39	38.05	6.10	42.21	6.83
	16	21.39	3.49	25.55	4.12	29.72	4.79	31.80	5.13	33.88	5.48	38.05	6.21	42.21	6.96
	18	21.39	3.56	25.55	4.18	29.72	4.87	31.80	5.22	33.88	5.58	38.05	6.32	42.21	7.09
	20	21.39	3.60	25.55	4.27	29.72	4.96	31.80	5.33	33.88	5.69	38.05	6.45	42.21	7.24
	21	21.39	3.64	25.55	4.29	29.72	5.00	31.80	5.37	33.88	5.73	38.05	6.51	42.21	7.31
	23	21.39	3.69	25.55	4.38	29.72	5.09	31.80	5.48	33.88	5.84	38.05	6.77	42.21	7.78
	25	21.39	3.75	25.55	4.44	29.72	5.28	31.80	5.73	33.88	6.21	38.05	7.22	42.21	8.30
	27	21.39	3.90	25.55	4.72	29.72	5.63	31.80	6.12	33.88	6.62	38.05	7.70	42.21	8.86
	29	21.39	4.12	25.55	5.00	29.72	5.99	31.80	6.51	33.88	7.05	38.05	8.21	42.21	9.46
	31	21.39	4.38	25.55	5.30	29.72	6.36	31.80	6.92	33.88	7.50	38.05	8.73	42.21	10.07
	33	21.39	4.61	25.55	5.63	29.72	6.75	31.80	7.35	33.88	7.98	38.05	9.29	42.21	10.74
	35	21.39	4.89	25.55	5.97	29.72	7.16	31.80	7.80	33.88	8.47	38.05	9.90	42.21	11.43
	37	21.39	5.17	25.55	6.32	29.72	7.59	31.80	8.28	33.88	8.99	38.05	10.52	42.21	12.16
	39	21.39	5.45	25.55	6.68	29.72	8.04	31.80	8.77	33.88	9.55	38.05	11.17	42.21	12.94
	42	21.39	5.69	25.55	7.07	29.72	8.43	31.80	9.24	33.88	10.02	38.05	11.87	42.21	13.72
44	21.39	5.92	25.55	7.46	29.72	8.82	31.80	9.56	33.88	10.48	38.05	12.51	42.21	14.50	
46	21.39	6.24	25.55	7.80	29.72	9.13	31.80	9.95	33.88	11.03	38.05	12.96	42.21	15.28	
50%	10	17.89	2.89	21.39	3.34	24.80	3.82	26.50	4.08	28.20	4.31	31.61	4.85	35.21	5.41
	12	17.89	2.91	21.39	3.38	24.80	3.88	26.50	4.12	28.20	4.40	31.61	4.94	35.21	5.50
	14	17.89	2.95	21.39	3.43	24.80	3.92	26.50	4.20	28.20	4.46	31.61	5.02	35.21	5.61
	16	17.89	3.00	21.39	3.47	24.80	3.99	26.50	4.27	28.20	4.53	31.61	5.11	35.21	5.69
	18	17.89	3.04	21.39	3.54	24.80	4.05	26.50	4.33	28.20	4.61	31.61	5.20	35.21	5.80
	20	17.89	3.08	21.39	3.58	24.80	4.12	26.50	4.40	28.20	4.70	31.61	5.28	35.21	5.91
	21	17.89	3.10	21.39	3.62	24.80	4.16	26.50	4.44	28.20	4.74	31.61	5.35	35.21	5.97
	23	17.89	3.15	21.39	3.67	24.80	4.23	26.50	4.53	28.20	4.83	31.61	5.43	35.21	6.10
	25	17.89	3.19	21.39	3.73	24.80	4.31	26.50	4.61	28.20	4.98	31.61	5.71	35.21	6.51
	27	17.89	3.26	21.39	3.88	24.80	4.55	26.50	4.92	28.20	5.28	31.61	6.08	35.21	6.94
	29	17.89	3.43	21.39	4.10	24.80	4.83	26.50	5.22	28.20	5.63	31.61	6.47	35.21	7.40
	31	17.89	3.62	21.39	4.33	24.80	5.11	26.50	5.54	28.20	5.97	31.61	6.88	35.21	7.87
	33	17.89	3.84	21.39	4.59	24.80	5.43	26.50	5.86	28.20	6.34	31.61	7.31	35.21	8.37
	35	17.89	4.05	21.39	4.85	24.80	5.74	26.50	6.21	28.20	6.71	31.61	7.76	35.21	8.88
	37	17.89	4.27	21.39	5.13	24.80	6.08	26.50	6.58	28.20	7.11	31.61	8.24	35.21	9.44
	39	17.89	4.51	21.39	5.41	24.80	6.43	26.50	6.96	28.20	7.55	31.61	8.73	35.21	10.03
	42	17.89	4.75	21.39	5.72	24.80	6.74	26.50	7.40	28.20	7.98	31.61	9.35	35.21	10.65
44	17.89	5.00	21.39	6.03	24.80	7.05	26.50	7.83	28.20	8.17	31.61	9.97	35.21	11.27	
46	17.89	5.23	21.39	6.34	24.80	7.36	26.50	8.21	28.20	8.42	31.61	10.60	35.21	11.89	

Note:

- 1, [redacted] is shown as reference
- 2, In heating mode, avoid the outdoor air temperature range from -15 to -20 degree C, when selecting the models
- 3, The above table shows the average value of conditions may operate
- 4, It is recommended to connect less 130%

18HP Heating mode

Combination (Capacity index)	Outdoor air temp.		Indoor temperature(°C DB)											
			16		18		20		21		22		24	
	°C DB	°C WB	TC	PI	TC	PI	TC	PI	TC	PI	TC	PI	TC	PI
130%	-19.8	-20	-19.8	-20	38.21	1.05	38.02	1.13	37.84	1.20	37.84	1.24	37.65	1.28
	-18.8	-19	-18.8	-19	38.77	1.08	38.58	1.15	38.58	1.22	38.40	1.26	38.40	1.29
	-16.7	-17	-16.7	-17	40.27	1.13	40.08	1.20	39.89	1.27	39.89	1.30	39.89	1.34
	-13.7	-15	-13.7	-15	41.95	1.18	41.77	1.25	41.58	1.31	41.58	1.35	41.39	1.38
	-11.8	-13	-11.8	-13	43.64	1.23	43.64	1.30	43.45	1.36	43.27	1.39	43.27	1.43
	-9.8	-11	-9.8	-11	45.70	1.28	45.52	1.35	45.33	1.41	45.33	1.44	45.33	1.47
	-9.5	-10	-9.5	-10	46.82	1.31	46.64	1.37	46.45	1.43	46.45	1.46	46.26	1.49
	-8.5	-9.1	-8.5	-9.1	47.76	1.34	47.58	1.39	47.58	1.45	47.39	1.48	47.39	1.51
	-7	-7.6	-7	-7.6	49.45	1.37	49.45	1.43	49.26	1.49	49.26	1.52	49.07	1.54
	-5	-5.6	-5	-5.6	52.07	1.43	51.88	1.48	51.69	1.53	51.69	1.56	51.51	1.59
	-3	-3.7	-3	-3.7	54.51	1.47	54.32	1.52	54.32	1.58	54.13	1.60	54.13	1.63
	0	-0.7	0	-0.7	58.81	1.54	58.81	1.59	58.62	1.64	58.62	1.66	58.44	1.69
	3	2.2	3	2.2	63.49	1.61	63.31	1.65	63.12	1.70	63.12	1.72	63.12	1.74
	5	4.1	5	4.1	66.68	1.65	66.49	1.69	66.49	1.73	66.31	1.75	66.31	1.77
	7	6	7	6	70.05	1.69	69.86	1.73	69.86	1.77	69.67	1.79	69.67	1.81
	9	7.9	9	7.9	73.61	1.72	73.42	1.76	73.42	1.80	73.24	1.82	71.73	1.78
11	9.8	11	9.8	77.35	1.76	77.17	1.79	76.79	1.82	74.17	1.74	71.73	1.67	
13	11.8	13	11.8	81.47	1.79	81.28	1.82	76.79	1.70	74.17	1.63	71.73	1.57	
15	13.7	15	13.7	85.41	1.82	81.66	1.73	76.79	1.60	74.17	1.54	71.73	1.48	
120%	-19.8	-20	-19.8	-20	38.02	1.15	37.84	1.22	37.65	1.29	37.65	1.32	37.65	1.36
	-18.8	-19	-18.8	-19	38.59	1.17	38.40	1.24	38.40	1.31	38.21	1.34	38.21	1.38
	-16.7	-17	-16.7	-17	40.09	1.22	39.90	1.29	39.65	1.35	39.71	1.38	39.71	1.42
	-13.7	-15	-13.7	-15	41.77	1.27	41.58	1.33	41.40	1.39	41.40	1.43	41.40	1.46
	-11.8	-13	-11.8	-13	43.46	1.32	43.46	1.38	43.27	1.44	43.27	1.47	43.08	1.50
	-9.8	-11	-9.8	-11	45.51	1.37	45.33	1.42	45.33	1.48	45.14	1.51	45.14	1.54
	-9.5	-10	-9.5	-10	46.64	1.39	46.45	1.45	46.27	1.50	46.27	1.53	46.27	1.56
	-8.5	-9.1	-8.5	-9.1	47.58	1.41	47.39	1.47	47.39	1.52	47.20	1.55	47.20	1.58
	-7	-7.6	-7	-7.6	49.26	1.45	49.26	1.50	49.07	1.56	49.07	1.58	48.89	1.61
	-5	-5.6	-5	-5.6	51.88	1.50	51.69	1.55	51.51	1.60	51.51	1.62	51.51	1.65
	-3	-3.7	-3	-3.7	54.32	1.54	54.32	1.59	54.13	1.64	54.13	1.66	53.95	1.69
	0	-0.7	0	-0.7	58.63	1.61	58.63	1.65	58.44	1.70	58.44	1.72	58.25	1.74
	3	2.2	3	2.2	63.31	1.67	63.12	1.71	63.12	1.75	62.93	1.77	62.93	1.79
	5	4.1	5	4.1	66.49	1.70	66.31	1.74	66.31	1.78	66.12	1.80	66.12	1.82
	7	6	7	6	69.87	1.74	69.87	1.78	69.68	1.81	68.56	1.79	66.31	1.71
	9	7.9	9	7.9	73.43	1.77	73.24	1.81	70.80	1.75	68.56	1.68	66.31	1.61
11	9.8	11	9.8	77.17	1.81	75.30	1.77	70.80	1.64	68.56	1.58	66.31	1.52	
13	11.8	13	11.8	79.98	1.79	75.30	1.66	70.80	1.54	68.56	1.48	66.31	1.43	
15	13.7	15	13.7	79.98	1.68	75.30	1.57	70.80	1.46	68.56	1.40	66.31	1.34	
110%	-19.8	-20	-19.8	-20	37.83	1.25	37.65	1.32	37.46	1.38	37.46	1.41	37.48	1.44
	-18.8	-19	-18.8	-19	38.40	1.27	38.21	1.34	38.21	1.40	38.21	1.43	38.02	1.46
	-16.7	-17	-16.7	-17	39.89	1.32	39.71	1.38	40.26	1.44	39.52	1.46	39.52	1.50
	-13.7	-15	-13.7	-15	41.58	1.36	41.40	1.42	41.21	1.47	41.21	1.50	41.21	1.53
	-11.8	-13	-11.8	-13	43.27	1.41	43.27	1.46	43.08	1.52	43.08	1.54	42.89	1.57
	-9.8	-11	-9.8	-11	45.33	1.45	45.14	1.50	45.14	1.56	44.95	1.58	44.95	1.61
	-9.5	-10	-9.5	-10	46.45	1.47	46.26	1.52	46.07	1.58	46.07	1.60	46.07	1.63
	-8.5	-9.1	-8.5	-9.1	47.39	1.49	47.20	1.54	47.20	1.59	47.01	1.62	47.01	1.64
	-7	-7.6	-7	-7.6	49.07	1.53	49.07	1.58	48.89	1.62	48.89	1.65	48.89	1.67
	-5	-5.6	-5	-5.6	51.70	1.57	51.51	1.62	51.32	1.66	51.32	1.69	51.32	1.71
	-3	-3.7	-3	-3.7	54.13	1.61	54.13	1.65	53.95	1.70	53.95	1.72	53.76	1.74
	0	-0.7	0	-0.7	58.44	1.67	58.44	1.71	58.25	1.75	58.25	1.77	58.25	1.79
	3	2.2	3	2.2	63.12	1.73	62.93	1.76	62.93	1.80	62.75	1.82	60.69	1.75
	5	4.1	5	4.1	66.31	1.76	66.31	1.80	64.99	1.78	62.75	1.71	60.69	1.64
	7	6	7	6	69.67	1.79	69.12	1.81	64.99	1.67	62.75	1.61	60.69	1.54
	9	7.9	9	7.9	73.24	1.82	69.12	1.70	64.99	1.57	62.75	1.51	60.69	1.45
11	9.8	11	9.8	73.24	1.71	69.12	1.60	64.99	1.48	62.75	1.42	60.69	1.37	
13	11.8	13	11.8	73.24	1.61	69.12	1.50	64.99	1.39	62.75	1.34	60.69	1.29	
15	13.7	15	13.7	73.24	1.43	69.12	1.41	64.99	1.31	62.75	1.26	60.69	1.22	
100%	-19.8	-20	-19.8	-20	37.65	1.35	37.46	1.41	37.46	1.47	37.27	1.50	37.27	1.52

	-18.8	-19	-18.8	-19	38.21	1.37	38.21	1.43	38.02	1.48	38.02	1.51	37.84	1.54
	-16.7	-17	-16.7	-17	39.71	1.41	39.52	1.46	39.52	1.52	39.34	1.55	39.34	1.57
	-13.7	-15	-13.7	-15	41.39	1.45	41.21	1.50	41.02	1.56	41.02	1.58	41.02	1.61
	-11.8	-13	-11.8	-13	43.08	1.49	43.08	1.54	42.89	1.59	42.89	1.62	42.89	1.64
	-9.8	-11	-9.8	-11	45.14	1.53	44.95	1.58	44.95	1.63	44.95	1.65	44.76	1.68
	-9.5	-10	-9.5	-10	46.26	1.56	46.08	1.60	46.08	1.65	45.89	1.67	45.89	1.70
	-8.5	-9.1	-8.5	-9.1	47.20	1.57	47.01	1.62	47.01	1.66	47.01	1.69	46.83	1.71
	-7	-7.6	-7	-7.6	48.89	1.60	48.89	1.65	48.70	1.69	48.70	1.71	48.70	1.74
	-5	-5.6	-5	-5.6	51.51	1.64	51.32	1.69	51.32	1.73	51.14	1.75	51.14	1.77
	-3	-3.7	-3	-3.7	53.94	1.68	53.94	1.53	53.75	1.76	53.75	1.78	53.75	1.80
	0	-0.7	0	-0.7	58.25	1.74	58.25	1.77	58.06	1.81	57.13	1.78	55.25	1.71
	3	2.2	3	2.2	62.94	1.79	62.75	1.82	59.00	1.68	57.13	1.62	55.25	1.55
	5	4.1	5	4.1	66.12	1.82	62.75	1.71	59.00	1.58	57.13	1.52	55.25	1.46
	7	6	7	6	66.49	1.73	62.75	1.61	59.00	1.49	57.13	1.43	55.25	1.38
	9	7.9	9	7.9	66.49	1.62	62.75	1.51	59.00	1.40	57.13	1.33	55.25	1.30
	11	9.8	11	9.8	66.49	1.53	62.75	1.42	59.00	1.32	57.13	1.27	55.25	1.22
	13	11.8	13	11.8	66.49	1.43	62.75	1.34	59.00	1.25	57.13	1.20	55.25	1.16
	15	13.7	15	13.7	66.49	1.35	62.75	1.26	59.00	1.18	57.13	1.13	55.25	1.09
90%	-19.8	-20	-19.8	-20	37.39	1.46	37.21	1.51	37.21	1.56	37.02	1.58	37.02	1.61
	-18.8	-19	-18.8	-19	37.96	1.47	37.96	1.52	37.77	1.57	37.77	1.60	37.77	1.62
	-16.7	-17	-16.7	-17	39.45	1.51	39.26	1.56	39.26	1.60	39.26	1.63	39.08	1.65
	-13.7	-15	-13.7	-15	41.13	1.54	40.95	1.59	40.95	1.64	40.76	1.66	40.76	1.68
	-11.8	-13	-11.8	-13	42.81	1.58	42.81	1.63	42.63	1.67	42.63	1.69	42.63	1.71
	-9.8	-11	-9.8	-11	44.87	1.62	44.87	1.66	44.68	1.70	44.68	1.72	44.68	1.75
	-9.5	-10	-9.5	-10	46.00	1.64	45.81	1.68	45.81	1.72	45.62	1.74	45.62	1.76
	-8.5	-9.1	-8.5	-9.1	46.93	1.65	46.93	1.70	46.74	1.74	46.74	1.76	46.74	1.78
	-7	-7.6	-7	-7.6	48.61	1.68	48.61	1.72	48.43	1.76	48.43	1.78	48.43	1.80
	-5	-5.6	-5	-5.6	51.23	1.72	51.05	1.76	51.05	1.79	50.85	1.81	49.55	1.76
	-3	-3.7	-3	-3.7	53.66	1.75	53.66	1.79	53.10	1.79	51.23	1.72	49.55	1.65
	0	-0.7	0	-0.7	58.15	1.80	56.47	1.76	53.10	1.63	51.23	1.56	49.55	1.50
	3	2.2	3	2.2	59.83	1.72	56.47	1.60	53.10	1.48	51.23	1.43	49.55	1.37
	5	4.1	5	4.1	59.83	1.61	56.47	1.50	53.10	1.40	51.23	1.34	49.55	1.29
	7	6	7	6	59.83	1.52	56.47	1.42	53.10	1.32	51.23	1.27	49.55	1.22
	9	7.9	9	7.9	59.83	1.43	56.47	1.33	53.10	1.24	51.23	1.20	49.55	1.15
11	9.8	11	9.8	59.83	1.35	56.47	1.26	53.10	1.17	51.23	1.13	49.55	1.09	
13	11.8	13	11.8	59.83	1.27	56.47	1.19	53.10	1.10	51.23	1.07	49.55	1.03	
15	13.7	15	13.7	59.83	1.20	56.47	1.12	53.10	1.05	51.23	1.01	49.55	0.97	
80%	-19.8	-20	-19.8	-20	37.27	1.56	37.09	1.60	37.09	1.65	37.09	1.67	36.90	1.69
	-18.8	-19	-18.8	-19	37.84	1.57	37.84	1.62	37.65	1.66	37.65	1.68	37.65	1.70
	-16.7	-17	-16.7	-17	39.33	1.60	39.15	1.64	39.15	1.69	39.15	1.71	39.15	1.73
	-13.7	-15	-13.7	-15	41.02	1.64	40.83	1.68	40.83	1.72	40.83	1.74	40.64	1.76
	-11.8	-13	-11.8	-13	42.71	1.67	42.71	1.71	42.52	1.75	42.52	1.77	42.52	1.79
	-9.8	-11	-9.8	-11	44.76	1.70	44.76	1.74	44.58	1.78	44.58	1.80	44.20	1.79
	-9.5	-10	-9.5	-10	45.89	1.72	45.69	1.75	45.70	1.79	45.70	1.81	44.20	1.74
	-8.5	-9.1	-8.5	-9.1	46.83	1.73	43.52	1.77	46.64	1.81	45.70	1.76	44.20	1.69
	-7	-7.6	-7	-7.6	48.51	1.76	48.51	1.79	47.20	1.75	45.70	1.69	44.20	1.62
	-5	-5.6	-5	-5.6	51.13	1.79	50.20	1.78	47.20	1.65	45.70	1.58	44.20	1.52
	-3	-3.7	-3	-3.7	53.19	1.80	50.20	1.68	47.20	1.55	45.70	1.49	44.20	1.43
	0	-0.7	0	-0.7	53.19	1.63	50.20	1.52	47.20	1.41	45.70	1.36	44.20	1.31
	3	2.2	3	2.2	53.19	1.49	50.20	1.39	47.20	1.29	45.70	1.24	44.20	1.20
	5	4.1	5	4.1	53.19	1.40	50.20	1.31	47.20	1.22	45.70	1.17	44.20	1.13
	7	6	7	6	53.19	1.32	50.20	1.23	47.20	1.15	45.70	1.11	44.20	1.07
	9	7.9	9	7.9	53.19	1.25	50.20	1.16	47.20	1.09	45.70	1.05	44.20	1.01
11	9.8	11	9.8	53.19	1.18	50.20	1.10	47.20	1.03	45.70	0.99	44.20	0.96	
13	11.8	13	11.8	53.19	1.11	50.20	1.04	47.20	0.97	45.70	0.94	44.20	0.90	
15	13.7	15	13.7	53.19	1.05	50.20	0.98	47.20	0.92	45.70	0.89	44.20	0.86	
70%	-19.8	-20	-19.8	-20	37.00	1.66	36.81	1.69	36.81	1.74	36.81	1.76	36.81	1.78
	-18.8	-19	-18.8	-19	37.56	1.67	37.56	1.71	37.38	1.75	37.38	1.77	37.38	1.79
	-16.7	-17	-16.7	-17	39.06	1.70	39.06	1.74	38.87	1.77	38.87	1.79	38.50	1.60
	-13.7	-15	-13.7	-15	40.74	1.73	40.55	1.76	40.55	1.80	39.80	1.77	38.50	1.70
	-11.8	-13	-11.8	-13	42.42	1.76	42.42	1.79	41.30	1.75	39.80	1.68	38.50	1.61
	-9.8	-11	-9.8	-11	44.48	1.78	43.91	1.78	41.30	1.65	39.80	1.59	38.50	1.52
-9.5	-10	-9.5	-10	45.60	1.80	43.91	1.73	41.30	1.60	39.80	1.54	38.50	1.48	

	-8.5	-9.1	-8.5	-9.1	46.53	1.81	43.91	1.68	41.30	1.56	39.80	1.50	38.50	1.44
	-7	-7.6	-7	-7.6	46.53	1.73	43.91	1.61	41.30	1.49	39.80	1.44	38.50	1.38
	-5	-5.6	-5	-5.6	46.53	1.62	43.91	1.51	41.30	1.40	39.80	1.35	38.50	1.60
	-3	-3.7	-3	-3.7	46.53	1.53	43.91	1.43	41.30	1.33	39.80	1.28	38.50	1.23
	0	-0.7	0	-0.7	46.53	1.39	43.91	1.30	41.30	1.21	39.80	1.16	38.50	1.12
	3	2.2	3	2.2	46.53	1.27	43.91	1.19	41.30	1.11	39.80	1.07	38.50	1.03
	5	4.1	5	4.1	46.53	1.20	43.91	1.12	41.30	1.05	39.80	1.01	38.50	0.97
	7	6	7	6	46.53	1.13	43.91	1.06	41.30	0.99	39.80	0.96	38.50	0.92
	9	7.9	9	7.9	46.53	1.07	43.91	1.00	41.30	0.94	39.80	0.91	38.50	0.87
	11	9.8	11	9.8	46.53	1.01	43.91	0.95	41.30	0.89	39.80	0.86	38.50	0.83
	13	11.8	13	11.8	46.53	0.96	43.91	0.90	41.30	0.84	39.80	0.81	38.50	0.79
	15	13.7	15	13.7	46.53	0.91	43.91	0.85	41.30	0.80	39.80	0.77	38.50	0.75
60%	-19.8	-20	-19.8	-20	36.90	1.76	36.71	1.79	35.40	1.72	34.28	1.65	33.15	1.59
	-18.8	-19	-18.8	-19	37.46	1.77	37.46	1.80	35.40	1.69	34.28	1.62	33.15	1.55
	-16.7	-17	-16.7	-17	38.96	1.79	37.65	1.74	35.40	1.61	34.28	1.55	33.15	1.48
	-13.7	-15	-13.7	-15	39.90	1.77	37.65	1.65	35.40	1.53	34.28	1.47	33.15	1.41
	-11.8	-13	-11.8	-13	39.90	1.68	37.65	1.56	35.40	1.45	34.28	1.40	33.15	1.34
	-9.8	-11	-9.8	-11	39.90	1.58	37.65	1.48	35.40	1.37	34.28	1.32	33.15	1.27
	-9.5	-10	-9.5	-10	39.90	1.54	37.65	1.44	35.40	1.33	34.28	1.28	33.15	1.23
	-8.5	-9.1	-8.5	-9.1	39.90	1.50	37.65	1.40	35.40	1.30	34.28	1.25	33.15	1.20
	-7	-7.6	-7	-7.6	39.90	1.43	37.65	1.34	35.40	1.24	34.28	1.20	33.15	1.15
	-5	-5.6	-5	-5.6	39.90	1.35	37.65	1.26	35.40	1.17	34.28	1.13	33.15	1.09
	-3	-3.7	-3	-3.7	39.90	1.28	37.65	1.19	35.40	1.11	34.28	1.07	33.15	1.03
	0	-0.7	0	-0.7	39.90	1.16	37.65	1.09	35.40	1.02	34.28	0.98	33.15	0.95
	3	2.2	3	2.2	39.90	1.07	37.65	1.00	35.40	0.94	34.28	0.90	33.15	0.87
	5	4.1	5	4.1	39.90	1.01	37.65	0.95	35.40	0.89	34.28	0.86	33.15	0.83
	7	6	7	6	39.90	0.96	37.65	0.90	35.40	0.84	34.28	0.81	33.15	0.79
	9	7.9	9	7.9	39.90	0.91	37.65	0.85	35.40	0.80	34.28	0.77	33.15	0.74
11	9.8	11	9.8	39.90	0.86	37.65	0.81	35.40	0.76	34.28	0.73	33.15	0.71	
13	11.8	13	11.8	39.90	0.81	37.65	0.77	35.40	0.72	34.28	0.70	33.15	0.67	
15	13.7	15	13.7	39.90	0.77	37.65	0.73	35.40	0.68	34.28	0.66	33.15	0.64	
50%	-19.8	-20	-19.8	-20	33.23	1.60	31.37	1.49	29.50	1.38	28.38	1.33	27.45	1.28
	-18.8	-19	-18.8	-19	33.23	1.56	31.37	1.46	29.50	1.35	28.38	1.30	27.45	1.25
	-16.7	-17	-16.7	-17	33.23	1.49	31.37	1.39	29.50	1.29	28.38	1.25	27.45	1.20
	-13.7	-15	-13.7	-15	33.23	1.42	31.37	1.33	29.50	1.23	28.38	1.19	27.45	1.14
	-11.8	-13	-11.8	-13	33.23	1.35	31.37	1.26	29.50	1.17	28.38	1.13	27.45	1.09
	-9.8	-11	-9.8	-11	33.23	1.28	31.37	1.19	29.50	1.11	28.38	1.07	27.45	1.03
	-9.5	-10	-9.5	-10	33.23	1.24	31.37	1.16	29.50	1.08	28.38	1.04	27.45	1.01
	-8.5	-9.1	-8.5	-9.1	33.23	1.21	31.37	1.13	29.50	1.06	28.38	1.02	27.45	0.98
	-7	-7.6	-7	-7.6	33.23	1.16	31.37	1.09	29.50	1.01	28.38	0.98	27.45	0.94
	-5	-5.6	-5	-5.6	33.23	1.10	31.37	1.03	29.50	0.96	28.38	0.93	27.45	0.89
	-3	-3.7	-3	-3.7	33.23	1.04	31.37	0.97	29.50	0.91	28.38	0.88	27.45	0.85
	0	-0.7	0	-0.7	33.23	0.95	31.37	0.89	29.50	0.84	28.38	0.81	27.45	0.78
	3	2.2	3	2.2	33.23	0.88	31.37	0.82	29.50	0.77	28.38	0.75	27.45	0.72
	5	4.1	5	4.1	33.23	0.83	31.37	0.78	29.50	0.73	28.38	0.71	27.45	0.69
	7	6	7	6	33.23	0.79	31.37	0.74	29.50	0.70	28.38	0.68	27.45	0.65
	9	7.9	9	7.9	33.23	0.75	31.37	0.71	29.50	0.66	28.38	0.64	27.45	0.62
11	9.8	11	9.8	33.23	0.71	31.37	0.67	29.50	0.63	28.38	0.61	27.45	0.59	
13	11.8	13	11.8	33.23	0.68	31.37	0.64	29.50	0.60	28.38	0.58	27.45	0.57	
15	13.7	15	13.7	33.23	0.64	31.37	0.61	29.50	0.57	28.38	0.56	27.45	0.54	

Note:

- 1, [redacted] is shown as reference
- 2, In heating mode, avoid the outdoor air temperature range from -15 to -20 degree C, when selecting the models
- 3, The above table shows the average value of conditions may operate
- 4, It is recommended to connect less 130%

20HP Cooling mode

Combination (%) (Capacity index)	Outdoor temperature (°C DB)	Indoor temperature(°C WB)													
		DB:20.8,WB:14		DB:23.3,WB:16		DB:25.8,WB:18		DB:27,WB:19		DB:28.2,WB:20		DB:30.7,WB:22		DB:32,WB:24	
		TC	PI	TC	PI	TC	PI	TC	PI	TC	PI	TC	PI	TC	PI
		kW	kW	kW	kW	kW	kW	kW	kW	kW	kW	kW	kW	kW	kW
130%	10	49.20	7.84	58.60	9.58	67.99	11.39	70.60	11.64	71.40	11.41	73.20	10.93	75.00	10.43
	12	49.20	7.97	58.60	9.76	67.99	11.62	69.60	11.57	70.60	11.34	72.20	10.84	74.00	10.68
	14	49.20	8.13	58.60	9.94	67.80	11.75	68.80	11.62	69.60	11.27	71.40	11.18	73.20	11.30
	16	49.20	8.27	58.60	10.15	67.00	11.71	67.80	11.53	68.60	11.66	70.40	11.78	72.20	11.89
	18	49.20	8.43	58.60	10.36	66.00	12.14	66.80	12.21	67.80	12.28	69.60	12.40	71.40	12.51
	20	49.20	8.62	58.60	11.02	65.00	12.74	66.00	12.81	66.80	12.88	68.60	12.99	70.40	13.13
	21	49.20	8.84	58.60	11.41	64.60	13.04	65.60	13.11	66.40	13.18	68.20	13.31	70.00	13.43
	23	49.20	9.49	58.60	12.24	63.80	13.63	64.60	13.70	65.40	13.77	67.20	13.91	68.99	14.05
	25	49.20	10.13	58.60	13.11	62.80	14.23	63.60	14.30	64.60	14.39	66.40	14.53	68.20	14.66
	27	49.20	10.81	58.60	14.02	62.00	14.82	62.80	14.92	63.60	14.98	65.40	15.15	67.20	15.31
	29	49.20	11.55	58.60	14.98	61.00	15.42	61.80	15.51	62.80	15.60	64.60	15.76	66.40	15.92
	31	49.20	12.33	58.40	15.86	60.00	16.04	61.00	16.13	61.80	16.20	63.60	16.38	65.40	16.57
	33	49.20	13.13	57.40	16.45	59.20	16.63	60.00	16.73	61.00	16.82	62.80	17.00	64.40	17.19
	35	49.20	14.00	56.40	17.05	58.20	17.25	59.20	17.35	60.00	17.44	61.80	17.64	63.60	17.83
	37	49.20	14.89	55.60	17.67	57.40	17.87	58.20	17.96	59.20	18.08	60.80	18.29	62.60	18.49
	39	49.20	15.86	54.60	17.85	56.40	18.47	57.40	18.58	58.20	18.70	60.00	18.90	61.80	19.13
	42	49.20	16.69	54.03	18.02	55.81	18.64	56.81	18.76	57.61	18.87	59.40	18.94	59.43	19.31
	44	49.20	17.54	53.47	18.20	55.21	18.74	56.21	18.93	56.42	18.92	57.24	19.01	58.01	19.39
46	49.20	18.39	53.24	18.37	54.62	18.99	55.62	19.00	55.95	19.04	56.24	19.08	57.13	20.03	
120%	10	45.40	7.15	54.00	8.73	62.80	10.38	67.20	11.23	70.40	11.71	72.00	11.25	73.60	10.81
	12	45.40	7.29	54.00	8.89	62.80	10.58	67.20	11.43	69.40	11.64	71.00	11.20	72.60	10.75
	14	45.40	7.42	54.00	9.07	62.80	10.79	67.20	11.66	68.40	11.57	70.20	11.14	71.80	11.20
	16	45.40	7.56	54.00	9.26	62.80	11.00	66.80	11.75	67.60	11.59	69.20	11.71	70.80	11.80
	18	45.40	7.70	54.00	9.44	62.80	11.36	65.80	12.14	66.60	12.19	68.20	12.30	70.00	12.42
	20	45.40	7.86	54.00	9.81	62.80	12.23	65.00	12.74	65.80	12.78	67.40	12.90	69.00	13.01
	21	45.40	7.93	54.00	10.15	62.80	12.67	64.40	13.04	65.20	13.08	67.00	13.20	68.60	13.33
	23	45.40	8.48	54.00	10.88	62.80	13.56	63.60	13.61	64.40	13.68	66.00	13.82	67.60	13.93
	25	45.40	9.05	54.00	11.64	61.80	14.16	62.60	14.21	63.40	14.27	65.20	14.41	66.80	14.55
	27	45.40	9.67	54.00	12.44	61.00	14.73	61.80	14.82	62.60	14.89	64.20	15.03	65.80	15.17
	29	45.40	10.31	54.00	13.29	60.00	15.33	60.80	15.42	61.60	15.49	63.20	15.65	65.00	15.79
	31	45.40	11.00	54.00	14.18	59.00	15.95	60.00	16.01	60.80	16.11	62.40	16.27	64.00	16.43
	33	45.40	11.71	54.00	15.12	58.20	16.54	59.00	16.63	59.80	16.70	61.40	16.89	63.00	17.05
	35	45.40	12.46	54.00	16.13	57.20	17.13	58.00	17.23	59.00	17.32	60.60	17.51	62.20	17.69
	37	45.40	13.26	54.00	17.18	56.40	17.76	57.20	17.85	58.00	17.94	59.60	18.12	61.20	18.33
	39	45.40	14.11	53.80	18.15	55.40	18.35	56.20	18.47	57.00	18.56	58.80	18.76	60.40	18.95
	42	45.40	14.63	53.22	18.32	54.82	18.53	55.62	18.64	56.42	18.73	58.22	18.83	58.08	19.14
	44	45.40	14.80	52.94	18.49	54.24	18.66	55.04	18.69	55.84	18.78	56.48	18.90	57.42	19.81
46	45.40	14.97	52.64	18.66	53.78	18.87	54.46	18.99	55.44	19.02	55.90	18.95	56.92	19.98	
110%	10	41.60	6.48	49.60	7.90	57.60	9.39	61.60	10.15	65.60	10.93	70.60	11.59	72.20	11.20
	12	41.60	6.62	49.60	8.06	57.60	9.58	61.60	10.36	65.60	11.14	69.81	11.55	71.20	11.14
	14	41.60	6.74	49.60	8.20	57.60	9.76	61.60	10.54	65.60	11.34	68.80	11.48	70.40	11.11
	16	41.60	6.85	49.60	8.36	57.60	9.94	61.60	10.75	65.60	11.57	68.00	11.62	69.40	11.73
	18	41.60	6.99	49.60	8.52	57.60	10.15	61.60	11.04	65.60	12.12	67.00	12.21	68.60	12.33
	20	41.60	7.13	49.60	8.71	57.60	10.75	61.60	11.87	64.60	12.72	66.20	12.81	67.60	12.92
	21	41.60	7.19	49.60	8.96	57.60	11.14	61.60	12.30	64.20	13.01	65.60	13.11	67.20	13.22
	23	41.60	7.54	49.60	9.60	57.60	11.94	61.60	13.20	63.20	13.59	64.81	13.72	66.20	13.84
	25	41.60	8.04	49.60	10.26	57.60	12.76	61.60	14.14	62.40	14.18	63.80	14.32	65.40	14.44
	27	41.60	8.57	49.60	10.97	57.60	13.66	60.60	14.73	61.40	14.78	63.00	14.92	64.40	15.05
	29	41.60	9.14	49.60	11.71	57.60	14.59	59.80	15.33	60.60	15.40	62.00	15.53	63.60	15.67
	31	41.60	9.74	49.60	12.49	57.60	15.58	58.80	15.92	59.60	15.99	61.20	16.13	62.60	16.29
	33	41.60	10.36	49.60	13.31	57.20	16.43	58.00	16.52	58.80	16.59	60.20	16.75	61.80	16.91
	35	41.60	11.02	49.60	14.18	56.20	17.02	57.00	17.12	57.80	17.21	59.20	17.37	60.80	17.53
	37	41.60	11.73	49.60	15.10	55.40	17.64	56.20	17.71	56.80	17.80	58.40	17.99	59.80	18.15
	39	41.60	12.46	49.60	16.09	54.40	18.24	55.20	18.33	56.00	18.42	57.40	18.60	59.00	18.79
	42	41.60	12.63	49.60	16.26	53.83	18.41	54.63	18.50	55.43	18.59	56.43	18.78	56.63	18.96
	44	41.60	12.81	49.60	16.43	53.26	18.58	54.06	18.67	54.86	18.76	55.90	18.83	56.06	19.64
46	41.60	13.13	49.60	16.60	52.75	18.75	53.49	18.95	54.45	18.93	55.29	19.80	55.58	19.85	
100%	10	37.80	5.87	45.00	7.10	52.40	8.41	56.00	9.10	59.60	9.78	67.00	11.18	70.80	11.57
	12	37.80	5.96	45.00	7.24	52.40	8.57	56.00	9.26	59.60	9.97	67.00	11.39	69.80	11.50

	14	37.80	6.07	45.00	7.38	52.40	8.73	56.00	9.44	59.60	10.15	67.00	11.61	69.00	11.43
	16	37.80	6.19	45.00	7.51	52.40	8.91	56.00	9.62	59.60	10.36	66.60	11.75	68.00	11.64
	18	37.80	6.30	45.00	7.65	52.40	9.07	56.00	9.81	59.60	10.56	65.80	12.14	67.20	12.23
	20	37.80	6.42	45.00	7.81	52.40	9.35	56.00	10.31	59.60	11.32	64.80	12.72	66.20	12.83
	21	37.80	6.48	45.00	7.88	52.40	9.69	56.00	10.68	59.60	11.71	64.40	13.01	65.80	13.13
	23	37.80	6.64	45.00	8.41	52.40	10.38	56.00	11.43	59.60	12.55	63.60	13.61	64.80	13.72
	25	37.80	7.08	45.00	8.98	52.40	11.11	56.00	12.26	59.60	13.45	62.60	14.21	64.00	14.32
	27	37.80	7.56	45.00	9.58	52.40	11.87	56.00	13.11	59.60	14.39	61.60	14.80	63.00	14.94
	29	37.80	8.04	45.00	10.22	52.40	12.67	56.00	14.00	59.40	15.28	60.80	15.42	62.20	15.53
	31	37.80	8.57	45.00	10.91	52.40	13.52	56.00	14.94	58.60	15.88	59.80	16.01	61.20	16.15
	33	37.80	9.10	45.00	11.62	52.40	14.41	56.00	15.95	57.60	16.47	59.00	16.61	60.40	16.77
	35	37.80	9.67	45.00	12.35	52.40	15.37	56.00	17.00	56.60	17.07	58.00	17.23	59.40	17.37
	37	37.80	10.29	45.00	13.15	52.40	16.38	54.99	17.60	55.80	17.69	57.20	17.84	58.40	17.99
	39	37.80	10.93	45.00	13.98	52.40	17.44	54.20	18.19	54.80	18.28	56.20	18.44	57.60	18.63
	42	37.80	11.61	45.00	14.66	52.40	18.29	53.08	18.36	54.24	18.66	54.90	18.88	56.48	19.14
	44	37.80	12.29	45.00	15.34	52.40	18.53	51.96	18.70	53.73	18.83	56.20	19.12	55.04	19.31
46	37.80	12.97	45.00	16.02	52.40	18.91	50.84	18.87	53.68	19.34	53.96	19.46	54.24	19.65	
90%	10	34.00	5.25	40.60	6.32	47.20	7.47	50.40	8.06	53.60	8.66	60.20	9.90	66.80	11.16
	12	34.00	5.34	40.60	6.44	47.20	7.61	50.40	8.20	53.60	8.82	60.20	10.08	66.80	11.36
	14	34.00	5.43	40.60	6.55	47.20	7.74	50.40	8.36	53.60	8.98	60.20	10.26	66.80	11.57
	16	34.00	5.52	40.60	6.67	47.20	7.90	50.40	8.52	53.60	9.16	60.20	10.47	66.60	11.78
	18	34.00	5.61	40.60	6.80	47.20	8.04	50.40	8.68	53.60	9.35	60.20	10.68	65.80	12.14
	20	34.00	5.73	40.60	6.96	47.20	8.20	50.40	8.87	53.60	9.69	60.20	11.48	64.80	12.72
	21	34.00	5.77	40.60	7.01	47.20	8.34	50.40	9.16	53.60	10.04	60.20	11.89	64.40	13.01
	23	34.00	5.89	40.60	7.29	47.20	8.93	50.40	9.83	53.60	10.77	60.20	12.76	63.40	13.61
	25	34.00	6.21	40.60	7.79	47.20	9.55	50.40	10.52	53.60	11.50	60.20	13.65	62.60	14.20
	27	34.00	6.60	40.60	8.29	47.20	10.19	50.40	11.23	53.60	12.30	60.20	14.62	61.60	14.80
	29	34.00	7.03	40.60	8.84	47.20	10.88	50.40	11.98	53.60	13.15	59.60	15.28	60.80	15.39
	31	34.00	7.47	40.60	9.42	47.20	11.59	50.40	12.78	53.60	14.02	58.60	15.88	59.80	16.01
	33	34.00	7.93	40.60	10.01	47.20	12.37	50.40	13.63	53.60	14.96	57.80	16.49	59.00	16.61
	35	34.00	8.43	40.60	10.65	47.20	13.17	50.40	14.52	53.60	15.95	56.80	17.09	58.00	17.23
	37	34.00	8.93	40.60	11.32	47.20	14.02	50.40	15.46	53.60	17.00	55.80	17.69	57.20	17.82
	39	34.00	9.48	40.60	12.05	47.20	14.91	50.40	16.47	53.60	18.10	55.00	18.31	56.20	18.44
42	34.00	9.92	40.60	12.78	47.20	15.64	50.40	17.05	53.60	18.24	54.49	18.93	55.70	19.02	
44	34.00	10.65	40.60	13.50	47.20	16.37	50.40	17.63	53.60	18.95	54.19	19.10	54.99	19.32	
46	34.00	11.23	40.60	14.08	47.20	16.95	50.40	18.22	53.60	19.28	53.88	19.32	54.00	19.54	
80%	10	30.20	4.65	36.00	5.57	41.80	6.55	44.80	7.06	47.80	7.56	53.60	8.64	59.40	9.74
	12	30.20	4.72	36.00	5.66	41.80	6.67	44.80	7.19	47.80	7.72	53.60	8.80	59.40	9.92
	14	30.20	4.81	36.00	5.77	41.80	6.78	44.80	7.31	47.80	7.86	53.60	8.96	59.40	10.10
	16	30.20	4.88	36.00	5.87	41.80	6.92	44.80	7.45	47.80	8.00	53.60	9.14	59.40	10.29
	18	30.20	4.97	36.00	5.98	41.80	7.06	44.80	7.61	47.80	8.16	53.60	9.33	59.40	10.49
	20	30.20	5.06	36.00	6.09	41.80	7.19	44.80	7.74	47.80	8.32	53.60	9.67	59.40	11.23
	21	30.20	5.11	36.00	6.14	41.80	7.26	44.80	7.84	47.80	8.50	53.60	10.01	59.40	11.64
	23	30.20	5.20	36.00	6.28	41.80	7.61	44.80	8.34	47.80	9.10	53.60	10.72	59.40	12.49
	25	30.20	5.36	36.00	6.67	41.80	8.13	44.80	8.91	47.80	9.71	53.60	11.48	59.40	13.36
	27	30.20	5.71	36.00	7.10	41.80	8.66	44.80	9.51	47.80	10.38	53.60	12.26	59.40	14.30
	29	30.20	6.07	36.00	7.56	41.80	9.23	44.80	10.13	47.80	11.09	53.60	13.08	59.40	15.28
	31	30.20	6.44	36.00	8.04	41.80	9.83	44.80	10.79	47.80	11.82	53.60	13.98	58.40	15.88
	33	30.20	6.85	36.00	8.55	41.80	10.47	44.80	11.50	47.80	12.58	53.60	14.89	57.60	16.47
	35	30.20	7.26	36.00	9.10	41.80	11.13	44.80	12.23	47.80	13.40	53.60	15.88	56.60	17.07
	37	30.20	7.70	36.00	9.64	41.80	11.85	44.80	13.04	47.80	14.27	53.60	16.93	55.80	17.66
	39	30.20	8.16	36.00	10.29	41.80	12.60	44.80	13.86	47.80	15.19	53.60	18.03	54.80	18.28
42	30.20	8.40	36.00	10.41	41.80	12.85	44.80	14.35	47.80	15.56	53.60	18.64	54.35	18.71	
44	30.20	8.77	36.00	10.53	41.80	13.09	44.80	14.60	47.80	15.80	53.60	18.77	53.90	18.90	
46	30.20	8.89	36.00	10.65	41.80	13.35	44.80	14.96	47.80	16.10	53.60	19.05	53.46	19.33	
70%	10	26.40	4.10	31.60	4.86	36.60	5.66	39.20	6.09	41.80	6.53	46.80	7.42	52.00	8.34
	12	26.40	4.15	31.60	4.93	36.60	5.77	39.20	6.21	41.80	6.64	46.80	7.56	52.00	8.50
	14	26.40	4.22	31.60	5.02	36.60	5.87	39.20	6.30	41.80	6.76	46.80	7.70	52.00	8.66
	16	26.40	4.28	31.60	5.11	36.60	5.98	39.20	6.44	41.80	6.90	46.80	7.84	52.00	8.82
	18	26.40	4.35	31.60	5.20	36.60	6.09	39.20	6.55	41.80	7.01	46.80	8.00	52.00	9.00
	20	26.40	4.42	31.60	5.29	36.60	6.21	39.20	6.67	41.80	7.15	46.80	8.16	52.00	9.26
	21	26.40	4.47	31.60	5.34	36.60	6.26	39.20	6.74	41.80	7.22	46.80	8.27	52.00	9.58
	23	26.40	4.54	31.60	5.43	36.60	6.39	39.20	6.97	41.80	7.58	46.80	8.87	52.00	10.26
25	26.40	4.63	31.60	5.66	36.60	6.80	39.20	7.45	41.80	8.09	46.80	9.49	52.00	10.97	
27	26.40	4.90	31.60	6.03	36.60	7.26	39.20	7.93	41.80	8.64	46.80	10.13	52.00	11.73	

	29	26.40	5.20	31.60	6.39	36.60	7.72	39.20	8.45	41.80	9.19	46.80	10.79	52.00	12.53
	31	26.40	5.50	31.60	6.78	36.60	8.23	39.20	8.98	41.80	9.78	46.80	11.50	52.00	13.36
	33	26.40	5.84	31.60	7.22	36.60	8.75	39.20	9.55	41.80	10.43	46.80	12.26	52.00	14.25
	35	26.40	6.19	31.60	7.65	36.60	9.28	39.20	10.17	41.80	11.09	46.80	13.06	52.00	15.19
	37	26.40	6.53	31.60	8.11	36.60	9.87	39.20	10.79	41.80	11.80	46.80	13.91	52.00	16.18
	39	26.40	6.92	31.60	8.59	36.60	10.47	39.20	11.48	41.80	12.53	46.80	14.78	52.00	17.23
	42	26.40	7.33	31.60	9.00	36.60	10.88	39.20	11.99	41.80	13.04	46.80	15.59	52.00	18.25
	44	26.40	7.81	31.60	9.51	36.60	11.22	39.20	12.50	41.80	13.55	46.80	16.30	52.00	18.86
	46	26.40	8.16	31.60	9.91	36.60	11.69	39.20	12.90	41.80	13.96	46.80	16.81	52.00	19.26
60%	10	22.60	3.55	27.00	4.17	31.40	4.83	33.60	5.18	35.80	5.52	40.20	6.25	44.60	7.01
	12	22.60	3.62	27.00	4.24	31.40	4.92	33.60	5.27	35.80	5.61	40.20	6.37	44.60	7.12
	14	22.60	3.67	27.00	4.31	31.40	4.99	33.60	5.36	35.80	5.73	40.20	6.48	44.60	7.26
	16	22.60	3.71	27.00	4.38	31.40	5.09	33.60	5.45	35.80	5.82	40.20	6.60	44.60	7.40
	18	22.60	3.78	27.00	4.44	31.40	5.18	33.60	5.54	35.80	5.93	40.20	6.71	44.60	7.54
	20	22.60	3.83	27.00	4.54	31.40	5.27	33.60	5.66	35.80	6.05	40.20	6.85	44.60	7.70
	21	22.60	3.87	27.00	4.56	31.40	5.31	33.60	5.70	35.80	6.09	40.20	6.92	44.60	7.77
	23	22.60	3.92	27.00	4.65	31.40	5.41	33.60	5.82	35.80	6.21	40.20	7.19	44.60	8.27
	25	22.60	3.99	27.00	4.72	31.40	5.61	33.60	6.09	35.80	6.60	40.20	7.67	44.60	8.82
	27	22.60	4.15	27.00	5.02	31.40	5.98	33.60	6.51	35.80	7.03	40.20	8.18	44.60	9.41
	29	22.60	4.38	27.00	5.31	31.40	6.37	33.60	6.92	35.80	7.49	40.20	8.73	44.60	10.06
	31	22.60	4.65	27.00	5.64	31.40	6.76	33.60	7.35	35.80	7.97	40.20	9.28	44.60	10.70
	33	22.60	4.90	27.00	5.98	31.40	7.17	33.60	7.81	35.80	8.48	40.20	9.87	44.60	11.41
	35	22.60	5.20	27.00	6.35	31.40	7.61	33.60	8.29	35.80	9.00	40.20	10.52	44.60	12.14
	37	22.60	5.50	27.00	6.71	31.40	8.06	33.60	8.80	35.80	9.55	40.20	11.18	44.60	12.92
	39	22.60	5.80	27.00	7.10	31.40	8.54	33.60	9.32	35.80	10.15	40.20	11.87	44.60	13.74
	42	22.60	6.04	27.00	7.51	31.40	8.96	33.60	9.82	35.80	10.65	40.20	12.61	44.60	14.57
44	22.60	6.29	27.00	7.93	31.40	9.37	33.60	10.15	35.80	11.13	40.20	13.29	44.60	15.40	
46	22.60	6.62	27.00	8.29	31.40	9.71	33.60	10.57	35.80	11.72	40.20	13.77	44.60	16.23	
50%	10	18.90	3.07	22.60	3.55	26.20	4.05	28.00	4.33	29.80	4.58	33.40	5.15	37.20	5.75
	12	18.90	3.09	22.60	3.60	26.20	4.12	28.00	4.38	29.80	4.67	33.40	5.25	37.20	5.84
	14	18.90	3.14	22.60	3.64	26.20	4.17	28.00	4.47	29.80	4.74	33.40	5.34	37.20	5.96
	16	18.90	3.18	22.60	3.69	26.20	4.24	28.00	4.54	29.80	4.81	33.40	5.43	37.20	6.05
	18	18.90	3.23	22.60	3.76	26.20	4.31	28.00	4.60	29.80	4.90	33.40	5.52	37.20	6.16
	20	18.90	3.28	22.60	3.80	26.20	4.38	28.00	4.67	29.80	4.99	33.40	5.61	37.20	6.28
	21	18.90	3.30	22.60	3.85	26.20	4.42	28.00	4.72	29.80	5.04	33.40	5.68	37.20	6.35
	23	18.90	3.34	22.60	3.89	26.20	4.49	28.00	4.81	29.80	5.13	33.40	5.77	37.20	6.48
	25	18.90	3.39	22.60	3.96	26.20	4.58	28.00	4.90	29.80	5.29	33.40	6.07	37.20	6.92
	27	18.90	3.46	22.60	4.12	26.20	4.83	28.00	5.22	29.80	5.61	33.40	6.46	37.20	7.38
	29	18.90	3.64	22.60	4.35	26.20	5.13	28.00	5.54	29.80	5.98	33.40	6.87	37.20	7.86
	31	18.90	3.85	22.60	4.60	26.20	5.43	28.00	5.89	29.80	6.35	33.40	7.31	37.20	8.36
	33	18.90	4.08	22.60	4.88	26.20	5.77	28.00	6.23	29.80	6.73	33.40	7.77	37.20	8.89
	35	18.90	4.31	22.60	5.15	26.20	6.09	28.00	6.60	29.80	7.13	33.40	8.25	37.20	9.44
	37	18.90	4.54	22.60	5.45	26.20	6.46	28.00	6.99	29.80	7.56	33.40	8.75	37.20	10.03
	39	18.90	4.79	22.60	5.75	26.20	6.83	28.00	7.40	29.80	8.02	33.40	9.28	37.20	10.65
	42	18.90	5.05	22.60	6.08	26.20	7.16	28.00	7.86	29.80	8.48	33.40	9.94	37.20	11.31
44	18.90	5.32	22.60	6.41	26.20	7.49	28.00	8.32	29.80	8.68	33.40	10.60	37.20	11.97	
46	18.90	5.56	22.60	6.74	26.20	7.82	28.00	8.72	29.80	8.94	33.40	11.26	37.20	12.63	

Note:

- 1, [redacted] is shown as reference
- 2, In heating mode, avoid the outdoor air temperature range from -15 to -20 degree C, when selecting the models
- 3, The above table shows the average value of conditions may operate
- 4, It is recommended to connect less 130%

20HP Heating mode

Combination (Capacity index)	Outdoor air temp.		Indoor temperature(°C DB)											
			16		18		20		21		22		24	
	°C DB	°C WB	TC	PI	TC	PI	TC	PI	TC	PI	TC	PI	TC	PI
130%	-19.8	-20	40.80	11.30	40.60	12.09	40.40	12.90	40.40	13.30	40.20	13.69	40.20	14.50
	-18.8	-19	41.40	11.55	41.20	12.34	41.20	13.13	41.00	13.53	41.00	13.90	40.80	14.69
	-16.7	-17	43.00	12.09	42.80	12.84	42.60	13.61	42.60	13.98	42.60	14.36	42.40	15.11
	-13.7	-15	44.80	12.65	44.60	13.38	44.40	14.11	44.40	14.46	44.20	14.84	44.20	15.56
	-11.8	-13	46.60	13.22	46.60	13.92	46.40	14.61	46.20	14.96	46.20	15.31	46.00	16.00
	-9.8	-11	48.80	13.80	48.60	14.46	48.40	15.13	48.40	15.46	48.40	15.79	48.20	16.46
	-9.5	-10	50.00	14.09	49.80	14.73	49.60	15.38	49.60	15.71	49.40	16.02	49.40	16.66
	-8.5	-9.1	51.00	14.34	50.80	14.96	50.80	15.61	50.60	15.92	50.60	16.23	50.40	16.87
	-7	-7.6	52.80	14.75	52.80	15.38	52.60	15.98	52.60	16.29	52.40	16.58	52.20	17.20
	-5	-5.6	55.60	15.31	55.40	15.90	55.20	16.48	55.20	16.77	55.00	17.04	55.00	17.62
	-3	-3.7	58.20	15.81	58.00	16.37	58.00	16.91	57.80	17.20	57.80	17.47	57.60	18.02
	0	-0.7	62.80	16.58	62.80	17.10	62.60	17.60	62.60	17.79	62.40	18.12	62.40	18.62
	3	2.2	67.79	17.27	67.60	17.75	67.40	18.22	67.40	18.45	67.40	18.70	67.20	19.16
	5	4.1	71.20	17.70	71.00	18.16	71.00	18.60	70.80	18.83	70.80	19.05	70.60	19.49
	7	6	74.80	18.12	74.60	18.53	74.60	18.97	74.40	19.18	74.40	19.39	71.40	18.62
	9	7.9	78.60	18.49	78.40	18.91	78.40	19.30	78.20	19.51	76.60	19.10	71.40	17.50
11	9.8	82.60	18.87	82.40	19.24	82.00	19.49	79.20	18.72	76.60	17.95	71.40	16.48	
13	11.8	87.00	19.22	86.80	19.60	82.00	18.27	79.20	17.54	76.60	16.85	71.40	15.46	
15	13.7	91.20	19.55	87.20	18.56	82.00	17.20	79.20	16.54	76.60	15.88	71.40	14.59	
120%	-19.8	-20	40.60	12.39	40.40	13.11	40.20	13.86	40.20	14.21	40.20	14.59	40.00	15.33
	-18.8	-19	41.20	12.61	41.00	13.34	41.00	14.07	40.80	14.42	40.80	14.80	40.60	15.52
	-16.7	-17	42.80	13.11	42.60	13.82	42.34	14.50	42.40	14.86	42.40	15.21	42.20	15.90
	-13.7	-15	44.60	13.63	44.40	14.30	44.20	14.96	44.20	15.32	44.20	15.65	44.00	16.31
	-11.8	-13	46.41	14.15	46.41	14.80	46.20	15.44	46.20	15.77	46.00	16.08	46.00	16.73
	-9.8	-11	48.60	14.69	48.40	15.29	48.40	15.92	48.20	16.23	48.20	16.52	48.00	17.14
	-9.5	-10	49.81	14.96	49.60	15.56	49.40	16.14	49.40	16.46	49.40	16.75	49.20	17.35
	-8.5	-9.1	50.80	15.19	50.60	15.77	50.60	16.35	50.40	16.65	50.40	16.96	50.20	17.54
	-7	-7.6	52.60	15.58	52.60	16.14	52.40	16.71	52.40	17.00	52.20	17.27	52.20	17.83
	-5	-5.6	55.40	16.08	55.20	16.62	55.00	17.16	55.00	17.43	55.00	17.70	54.81	18.22
	-3	-3.7	58.00	16.56	58.00	17.08	57.80	17.58	57.80	17.83	57.60	18.10	57.60	18.60
	0	-0.7	62.60	17.27	62.60	17.75	62.40	18.20	62.40	18.45	62.20	18.68	62.20	19.16
	3	2.2	67.60	17.91	67.40	18.35	67.40	18.79	67.20	19.01	67.20	19.22	65.80	19.12
	5	4.1	71.00	18.31	70.80	18.72	70.80	19.14	70.60	19.35	70.60	19.55	65.80	17.95
	7	6	74.60	18.68	74.60	19.08	74.40	19.47	73.21	19.20	70.80	18.41	65.80	16.89
	9	7.9	78.41	19.06	78.20	19.43	75.60	18.79	73.21	18.04	70.80	17.31	65.80	15.90
11	9.8	82.40	19.39	80.40	19.06	75.60	17.66	73.21	16.98	70.80	16.29	65.80	14.98	
13	11.8	85.40	19.20	80.40	17.87	75.60	16.56	73.21	15.94	70.80	15.32	65.80	14.09	
15	13.7	85.40	18.08	80.40	16.83	75.60	15.63	73.21	15.02	70.80	14.44	65.80	13.30	
110%	-19.8	-20	40.40	13.47	40.20	14.13	40.00	14.82	40.00	15.15	40.02	15.48	39.80	16.17
	-18.8	-19	41.00	13.67	40.80	14.34	40.80	15.00	40.80	15.34	40.60	15.67	40.60	16.33
	-16.7	-17	42.60	14.13	42.40	14.77	42.99	15.42	42.20	15.73	42.20	16.06	42.00	16.69
	-13.7	-15	44.40	14.61	44.21	15.23	44.00	15.83	44.00	16.15	44.00	16.46	43.80	17.06
	-11.8	-13	46.20	15.11	46.20	15.69	46.00	16.27	46.00	16.56	45.80	16.85	45.80	17.45
	-9.8	-11	48.40	15.59	48.20	16.15	48.20	16.71	48.00	17.00	48.00	17.27	48.00	17.83
	-9.5	-10	49.60	15.83	49.40	16.37	49.20	16.94	49.20	17.20	49.20	17.48	49.00	18.02
	-8.5	-9.1	50.60	16.04	50.40	16.58	50.40	17.12	50.20	17.39	50.20	17.66	50.20	16.10
	-7	-7.6	52.40	16.42	52.40	16.91	52.20	17.43	52.20	17.70	52.20	17.95	52.00	18.47
	-5	-5.6	55.20	16.87	55.00	17.37	54.80	17.85	54.80	18.10	54.80	18.35	54.60	18.85
	-3	-3.7	57.80	17.31	57.80	17.77	57.60	18.24	57.60	18.47	57.40	18.70	57.40	19.18
	0	-0.7	62.40	17.95	62.40	18.39	62.20	18.83	62.20	19.03	62.20	19.26	60.40	18.89
	3	2.2	67.40	18.56	67.20	18.95	67.20	19.35	67.00	19.53	64.80	18.74	60.40	17.19
	5	4.1	70.80	18.91	70.80	19.30	69.40	19.12	67.00	18.35	64.80	17.62	60.40	16.17
	7	6	74.40	19.26	73.80	19.39	69.40	17.95	67.00	17.25	64.80	16.56	60.40	15.21
	9	7.9	78.20	19.57	73.80	18.22	69.40	16.89	67.00	16.23	64.80	15.59	60.40	14.34
11	9.8	78.20	18.41	73.80	17.14	69.40	15.90	67.00	15.29	64.80	14.69	60.40	13.53	
13	11.8	78.20	17.27	73.80	16.08	69.40	14.94	67.00	14.38	64.80	13.82	60.40	12.74	
15	13.7	78.20	15.34	73.80	15.17	69.40	14.11	67.00	13.57	64.80	13.07	60.40	12.05	

100%	-19.8	-20	40.20	14.55	40.00	15.15	40.00	15.77	39.80	16.08	39.80	16.37	39.60	17.00
	-18.8	-19	40.80	14.73	40.80	15.33	40.60	15.94	40.60	16.25	40.40	16.56	40.40	17.16
	-16.7	-17	42.40	15.15	42.20	15.73	42.20	16.31	42.00	16.60	42.00	16.89	42.00	17.48
	-13.7	-15	44.20	15.58	44.00	16.15	43.80	16.71	43.80	17.00	43.80	17.27	43.60	17.83
	-11.8	-13	46.00	16.04	46.00	16.56	45.80	17.10	45.80	17.37	45.80	17.64	45.60	18.18
	-9.8	-11	48.20	16.48	48.00	17.00	48.00	17.50	48.00	17.77	47.80	18.02	47.80	18.51
	-9.5	-10	49.40	16.71	49.20	17.20	49.20	17.70	49.00	17.95	49.00	18.20	48.80	18.70
	-8.5	-9.1	50.40	16.89	50.20	17.39	50.20	17.87	50.20	18.12	50.00	18.37	50.00	18.85
	-7	-7.6	52.20	17.23	52.20	17.70	52.00	18.16	52.00	18.41	52.00	18.64	51.80	19.12
	-5	-5.6	55.00	17.66	54.80	18.10	54.80	18.56	54.60	18.76	54.60	18.99	54.40	19.45
	-3	-3.7	57.60	18.06	57.60	18.40	57.40	18.91	57.40	19.12	57.40	19.32	55.00	18.51
	0	-0.7	62.20	18.64	62.20	19.03	62.00	19.43	61.00	19.12	59.00	18.33	55.00	16.81
	3	2.2	67.20	19.18	67.00	19.53	63.00	18.08	61.00	17.37	59.00	16.69	55.00	15.31
	5	4.1	70.60	19.53	67.00	18.35	63.00	17.00	61.00	16.35	59.00	15.71	55.00	14.44
	7	6	71.00	18.53	67.00	17.25	63.00	16.00	61.00	15.40	59.00	14.80	55.00	13.61
	9	7.9	71.00	17.41	67.00	16.23	63.00	15.07	61.00	14.32	59.00	13.94	55.00	12.84
11	9.8	71.00	16.40	67.00	15.29	63.00	14.21	61.00	13.67	59.00	13.15	55.00	12.13	
13	11.8	71.00	15.40	67.00	14.38	63.00	13.38	61.00	12.88	59.00	12.40	55.00	11.45	
15	13.7	71.00	14.52	67.00	13.57	63.00	12.63	61.00	12.18	59.00	11.72	55.00	10.85	
90%	-19.8	-20	39.93	15.63	39.73	16.17	39.73	16.73	39.53	17.00	39.53	17.29	39.53	17.83
	-18.8	-19	40.53	15.79	40.53	16.35	40.33	16.89	40.33	17.16	40.33	17.43	40.13	17.97
	-16.7	-17	42.13	16.19	41.92	16.71	41.92	17.23	41.92	17.50	41.73	17.75	41.73	18.26
	-13.7	-15	43.92	16.58	43.72	17.08	43.72	17.58	43.52	17.83	43.52	18.08	43.52	18.58
	-11.8	-13	45.72	16.98	45.72	17.45	45.52	17.93	45.52	18.18	45.52	18.41	45.32	18.89
	-9.8	-11	47.92	17.37	47.92	17.83	47.71	18.29	47.71	18.51	47.71	18.76	47.51	19.22
	-9.5	-10	49.11	17.58	48.92	18.04	48.92	18.47	48.72	18.70	48.72	18.93	48.72	19.37
	-8.5	-9.1	50.11	17.77	50.11	18.20	49.91	18.64	49.91	18.85	49.91	19.07	49.31	19.26
	-7	-7.6	51.91	18.06	51.91	18.47	51.71	18.91	51.71	19.12	51.71	19.32	49.31	18.39
	-5	-5.6	54.70	18.45	54.51	18.85	54.51	19.24	54.30	19.45	52.91	18.85	49.31	17.29
	-3	-3.7	57.30	18.81	57.30	19.18	56.70	19.26	54.70	18.49	52.91	17.75	49.31	16.29
	0	-0.7	62.09	19.34	60.29	18.87	56.70	17.48	54.70	16.79	52.91	16.12	49.31	14.81
	3	2.2	63.89	18.43	60.29	17.16	56.70	15.92	54.70	15.31	52.91	14.71	49.31	13.55
	5	4.1	63.89	17.33	60.29	16.14	56.70	15.00	54.70	14.42	52.91	13.88	49.31	12.78
	7	6	63.89	16.29	60.29	15.21	56.70	14.13	54.70	13.61	52.91	13.09	49.31	12.07
	9	7.9	63.89	15.36	60.29	14.32	56.70	13.32	54.70	12.84	52.91	12.36	49.31	11.41
11	9.8	63.89	14.46	60.29	13.51	56.70	12.59	54.70	12.13	52.91	11.68	49.31	10.80	
13	11.8	63.89	13.61	60.29	12.74	56.70	11.86	54.70	11.45	52.91	11.03	49.31	10.20	
15	13.7	63.89	12.86	60.29	12.03	56.70	11.24	54.70	10.85	52.91	10.45	49.31	9.68	
80%	-19.8	-20	39.80	16.71	39.60	17.18	39.60	17.68	39.60	17.93	39.40	18.18	39.40	18.66
	-18.8	-19	40.40	16.85	40.40	17.35	40.20	17.83	40.20	18.08	40.20	18.31	40.00	18.80
	-16.7	-17	42.00	17.20	41.80	17.66	41.80	18.14	41.80	18.37	41.80	18.60	41.60	19.05
	-13.7	-15	43.80	17.56	43.60	17.99	43.60	18.45	43.60	18.66	43.40	18.89	43.40	19.34
	-11.8	-13	45.60	17.91	45.60	18.35	45.40	18.76	45.40	18.97	45.40	19.20	44.00	18.68
	-9.8	-11	47.80	18.26	47.80	18.68	47.60	19.09	47.60	19.28	47.20	19.24	44.00	17.64
	-9.5	-10	49.00	18.45	48.79	18.85	48.80	19.24	48.80	19.45	47.20	18.68	44.00	17.12
	-8.5	-9.1	50.00	18.62	46.47	19.01	49.80	19.39	48.80	18.95	47.20	18.18	44.00	16.66
	-7	-7.6	51.80	18.89	51.80	19.26	50.40	18.85	48.80	18.10	47.20	17.37	44.00	15.94
	-5	-5.6	54.60	19.22	53.60	19.12	50.40	17.70	48.80	17.02	47.20	16.33	44.00	15.00
	-3	-3.7	56.80	19.32	53.60	17.99	50.40	16.66	48.80	16.04	47.20	15.40	44.00	14.17
	0	-0.7	56.80	17.54	53.60	16.33	50.40	15.17	48.80	14.61	47.20	14.03	44.00	12.92
	3	2.2	56.80	15.98	53.60	14.90	50.40	13.86	48.80	13.34	47.20	12.84	44.00	11.84
	5	4.1	56.80	15.04	53.60	14.05	50.40	13.07	48.80	12.59	47.20	12.14	44.00	11.20
	7	6	56.80	14.17	53.60	13.26	50.40	12.34	48.80	11.91	47.20	11.47	44.00	10.60
	9	7.9	56.80	13.38	53.60	12.51	50.40	11.66	48.80	11.24	47.20	10.85	44.00	10.04
11	9.8	56.80	12.63	53.60	11.82	50.40	11.03	48.80	10.64	47.20	10.26	44.00	9.52	
13	11.8	56.80	11.91	53.60	11.16	50.40	10.43	48.80	10.06	47.20	9.70	44.00	9.00	
15	13.7	56.80	11.26	53.60	10.58	50.40	9.89	48.80	9.54	47.20	9.20	44.00	8.56	
70%	-19.8	-20	39.51	17.79	39.31	18.20	39.31	18.64	39.31	18.85	39.31	19.07	38.31	18.87
	-18.8	-19	40.11	17.93	40.11	18.35	39.91	18.76	39.91	18.97	39.91	19.20	38.31	18.47
	-16.7	-17	41.71	18.22	41.71	18.64	41.51	19.03	41.51	19.24	41.11	17.14	38.31	17.62
	-13.7	-15	43.50	18.53	43.30	18.93	43.30	19.32	42.50	19.03	41.11	18.26	38.31	16.75
-11.8	-13	45.30	18.85	45.30	19.22	44.10	18.76	42.50	18.04	41.11	17.31	38.31	15.87	

	-9.8	-11	47.49	19.16	46.89	19.14	44.10	17.72	42.50	17.04	41.11	16.35	38.31	15.02
	-9.5	-10	48.69	19.32	46.89	18.58	44.10	17.20	42.50	16.54	41.11	15.89	38.31	14.61
	-8.5	-9.1	49.69	19.43	46.89	18.08	44.10	16.75	42.50	16.10	41.11	15.48	38.31	14.23
	-7	-7.6	49.69	18.55	46.89	17.27	44.10	16.02	42.50	15.42	41.11	14.82	38.31	13.63
	-5	-5.6	49.69	17.43	46.89	16.25	44.10	15.09	42.50	14.50	41.11	17.13	38.31	12.86
	-3	-3.7	49.69	16.42	46.89	15.31	44.10	14.23	42.50	13.69	41.11	13.17	38.31	12.16
	0	-0.7	49.69	14.94	46.89	13.96	44.10	12.99	42.50	12.51	41.11	12.05	38.31	11.14
	3	2.2	49.69	13.65	46.89	12.78	44.10	11.91	42.50	11.47	41.11	11.05	38.31	10.22
	5	4.1	49.69	12.88	46.89	12.05	44.10	11.26	42.50	10.85	41.11	10.45	38.31	9.68
	7	6	49.69	12.18	46.89	11.41	44.10	10.64	42.50	10.26	41.11	9.91	38.31	9.18
	9	7.9	49.69	11.51	46.89	10.78	44.10	10.08	42.50	9.72	41.11	9.39	38.31	8.71
	11	9.8	49.69	10.89	46.89	10.20	44.10	9.56	42.50	9.23	41.11	8.91	38.31	8.27
	13	11.8	49.69	10.29	46.89	9.66	44.10	9.04	42.50	8.75	41.11	8.44	38.31	7.85
	15	13.7	49.69	9.74	46.89	9.16	44.10	8.58	42.50	8.31	41.11	8.02	38.31	7.48
60%	-19.8	-20	39.40	18.87	39.20	19.22	37.80	18.49	36.60	17.76	35.40	17.06	33.00	15.65
	-18.8	-19	40.00	18.99	40.00	19.34	37.80	18.10	36.60	17.39	35.40	16.68	33.00	15.31
	-16.7	-17	41.60	19.24	40.20	18.64	37.80	17.27	36.60	16.60	35.40	15.94	33.00	14.65
	-13.7	-15	42.60	19.03	40.20	17.70	37.80	16.41	36.60	15.79	35.40	15.17	33.00	13.94
	-11.8	-13	42.60	18.01	40.20	16.77	37.80	15.56	36.60	14.98	35.40	14.40	33.00	13.32
	-9.8	-11	42.60	17.02	40.20	15.85	37.80	14.73	36.60	14.17	35.40	13.63	33.00	12.57
	-9.5	-10	42.60	16.54	40.20	15.42	37.80	14.32	36.60	13.80	35.40	13.26	33.00	12.22
	-8.5	-9.1	42.60	16.10	40.20	15.02	37.80	13.96	36.60	13.44	35.40	12.92	33.00	11.93
	-7	-7.6	42.60	15.40	40.20	14.38	37.80	13.36	36.60	12.88	35.40	12.38	33.00	11.45
	-5	-5.6	42.60	14.50	40.20	13.55	37.80	12.61	36.60	12.15	35.40	11.70	33.00	10.83
	-3	-3.7	42.60	13.69	40.20	12.80	37.80	11.93	36.60	11.51	35.40	11.07	33.00	10.24
	0	-0.7	42.60	12.51	40.20	11.72	37.80	10.93	36.60	10.56	35.40	10.16	33.00	9.41
	3	2.2	42.60	11.47	40.20	10.76	37.80	10.06	36.60	9.70	35.40	9.37	33.00	8.68
	5	4.1	42.60	10.85	40.20	10.18	37.80	9.52	36.60	9.20	35.40	8.87	33.00	8.25
	7	6	42.60	10.26	40.20	9.64	37.80	9.02	36.60	8.73	35.40	8.44	33.00	7.83
	9	7.9	42.60	9.72	40.20	9.14	37.80	8.56	36.60	8.29	35.40	8.00	33.00	7.46
11	9.8	42.60	9.23	40.20	8.68	37.80	8.14	36.60	7.88	35.40	7.60	33.00	7.11	
13	11.8	42.60	8.73	40.20	8.23	37.80	7.73	36.60	7.48	35.40	7.23	33.00	6.75	
15	13.7	42.60	8.31	40.20	7.81	37.80	7.36	36.60	7.13	35.40	6.90	33.00	6.44	
50%	-19.8	-20	35.49	17.16	33.49	15.98	31.50	14.84	30.30	14.30	29.31	13.73	27.31	12.65
	-18.8	-19	35.49	16.79	33.49	15.65	31.50	14.54	30.30	13.98	29.31	13.44	27.31	12.40
	-16.7	-17	35.49	16.02	33.49	14.94	31.50	13.90	30.30	13.38	29.31	12.88	27.31	11.89
	-13.7	-15	35.49	15.25	33.49	14.23	31.50	13.24	30.30	12.76	29.31	12.28	27.31	11.34
	-11.8	-13	35.49	14.48	33.49	13.53	31.50	12.59	30.30	12.13	29.31	11.68	27.31	10.80
	-9.8	-11	35.49	13.71	33.49	12.82	31.50	11.95	30.30	11.51	29.31	11.10	27.31	10.26
	-9.5	-10	35.49	13.34	33.49	12.47	31.50	11.64	30.30	11.22	29.31	10.80	27.31	9.99
	-8.5	-9.1	35.49	13.01	33.49	12.18	31.50	11.34	30.30	10.95	29.31	10.56	27.31	9.77
	-7	-7.6	35.49	12.47	33.49	11.68	31.50	10.89	30.30	10.51	29.31	10.14	27.31	9.39
	-5	-5.6	35.49	11.76	33.49	11.03	31.50	10.31	30.30	9.95	29.31	9.60	27.31	8.89
	-3	-3.7	35.49	11.14	33.49	10.45	31.50	9.77	30.30	9.43	29.31	9.10	27.31	8.46
	0	-0.7	35.49	10.22	33.49	9.60	31.50	9.00	30.30	8.69	29.31	8.39	27.31	7.81
	3	2.2	35.49	9.41	33.49	8.85	31.50	8.29	30.30	8.02	29.31	7.75	27.31	7.23
	5	4.1	35.49	8.93	33.49	8.39	31.50	7.88	30.30	7.63	29.31	7.38	27.31	6.88
	7	6	35.49	8.48	33.49	7.98	31.50	7.50	30.30	7.25	29.31	7.02	27.31	6.57
	9	7.9	35.49	8.04	33.49	7.58	31.50	7.13	30.30	6.92	29.31	6.69	27.31	6.25
11	9.8	35.49	7.65	33.49	7.21	31.50	6.79	30.30	6.59	29.31	6.38	27.31	5.96	
13	11.8	35.49	7.27	33.49	6.86	31.50	6.46	30.30	6.28	29.31	6.07	27.31	5.69	
15	13.7	35.49	6.92	33.49	6.55	31.50	6.17	30.30	5.98	29.31	5.80	27.31	5.44	

Note:

- 1, [] is shown as reference
- 2, In heating mode, avoid the outdoor air temperature range from -15 to -20 degree C, when selecting the models
- 3, The above table shows the average value of conditions may operate
- 4, It is recommended to connect less 130%

30HP cooling mode

Combination (%) (Capacity index)	Outdoor temperature (°C DB)	Indoor temperature(°C WB)													
		DB:20.8,WB:14		DB:23.3,WB:16		DB:25.8,WB:18		DB:27,WB:19		DB:28.2,WB:20		DB:30.7,WB:22		DB:32,WB:24	
		TC	PI	TC	PI	TC	PI	TC	PI	TC	PI	TC	PI	TC	PI
130%	10	74.68	1.23	88.94	1.50	103.21	1.78	107.16	1.82	108.37	1.79	111.10	1.71	113.84	1.63
	12	74.68	1.25	88.94	1.53	103.21	1.82	105.64	1.81	107.16	1.77	109.59	1.70	112.32	1.67
	14	74.68	1.27	88.94	1.56	102.91	1.84	104.42	1.82	105.64	1.76	108.37	1.75	111.10	1.77
	16	74.68	1.29	88.94	1.59	101.70	1.83	102.94	1.80	104.12	1.82	106.85	1.84	109.59	1.86
	18	74.68	1.32	88.94	1.62	100.18	1.90	101.30	1.91	102.91	1.92	105.64	1.94	108.37	1.96
	20	74.68	1.35	88.94	1.72	98.66	1.99	100.18	2.00	101.39	2.01	104.12	2.03	106.85	2.05
	21	74.68	1.38	88.94	1.79	98.05	2.04	99.57	2.05	100.78	2.06	103.51	2.08	106.24	2.10
	23	74.68	1.48	88.94	1.91	96.84	2.13	98.05	2.14	99.26	2.15	101.99	2.18	104.72	2.20
	25	74.68	1.58	88.94	2.05	95.32	2.23	96.53	2.24	98.05	2.25	100.78	2.27	103.51	2.29
	27	74.68	1.69	88.94	2.19	94.10	2.32	95.32	2.33	96.53	2.34	99.26	2.37	101.99	2.39
	29	74.68	1.81	88.94	2.34	92.59	2.41	93.80	2.43	95.32	2.44	98.05	2.47	100.78	2.49
	31	74.68	1.93	88.64	2.48	91.07	2.51	92.59	2.52	93.80	2.53	96.53	2.56	99.26	2.59
	33	74.68	2.05	87.12	2.57	89.85	2.60	91.07	2.62	92.59	2.63	95.32	2.66	97.74	2.69
	35	74.68	2.19	85.60	2.67	88.33	2.70	89.85	2.71	91.07	2.73	93.80	2.76	96.53	2.79
	37	74.68	2.33	84.39	2.76	87.12	2.80	88.33	2.81	89.85	2.83	92.28	2.86	95.01	2.89
	39	74.68	2.48	82.87	2.79	85.60	2.89	87.12	2.91	88.33	2.93	91.07	2.96	93.80	2.99
	42	74.68	2.61	82.02	2.82	84.70	2.92	86.22	2.93	87.44	2.95	90.17	2.96	90.20	3.02
	44	74.68	2.68	81.42	2.83	84.26	2.92	85.77	2.95	86.54	2.96	88.53	2.97	89.13	3.03
46	74.68	2.81	80.90	2.86	83.36	2.95	84.88	2.97	85.28	2.97	86.12	2.98	87.38	3.08	
120%	10	68.91	1.12	81.96	1.37	95.32	1.62	102.00	1.76	106.86	1.83	109.29	1.76	111.72	1.69
	12	68.91	1.14	81.96	1.39	95.32	1.66	102.00	1.79	105.34	1.82	107.76	1.75	110.19	1.68
	14	68.91	1.16	81.96	1.42	95.32	1.69	102.00	1.82	103.82	1.81	106.55	1.74	108.98	1.75
	16	68.91	1.18	81.96	1.45	95.32	1.72	101.30	1.84	102.60	1.81	105.03	1.83	107.46	1.85
	18	68.91	1.20	81.96	1.48	95.32	1.78	99.88	1.90	101.09	1.91	103.52	1.93	106.25	1.94
	20	68.91	1.23	81.96	1.53	95.32	1.91	98.66	1.99	99.88	2.00	102.30	2.02	104.73	2.04
	21	68.91	1.24	81.96	1.59	95.32	1.98	97.74	2.04	98.96	2.05	101.70	2.07	104.13	2.09
	23	68.91	1.33	81.96	1.70	95.32	2.12	96.54	2.13	97.74	2.14	100.17	2.16	102.60	2.18
	25	68.91	1.42	81.96	1.82	93.80	2.22	95.02	2.22	96.23	2.23	98.96	2.25	101.39	2.28
	27	68.91	1.51	81.96	1.95	92.59	2.31	93.80	2.32	95.02	2.33	97.45	2.35	99.88	2.37
	29	68.91	1.61	81.96	2.08	91.07	2.40	92.29	2.41	93.50	2.42	95.93	2.45	98.66	2.47
	31	68.91	1.72	81.96	2.22	89.55	2.50	91.07	2.51	92.29	2.52	94.72	2.55	97.14	2.57
	33	68.91	1.83	81.96	2.37	88.33	2.59	89.55	2.60	90.76	2.61	93.19	2.64	95.62	2.67
	35	68.91	1.95	81.96	2.52	86.82	2.68	88.03	2.70	89.55	2.71	91.98	2.74	94.41	2.77
	37	68.91	2.08	81.96	2.69	85.60	2.78	86.82	2.79	88.03	2.81	90.46	2.84	92.89	2.87
	39	68.91	2.21	81.66	2.84	84.09	2.87	85.31	2.89	86.52	2.90	89.25	2.94	91.68	2.96
	42	68.91	2.27	81.00	2.86	83.43	2.89	84.65	2.91	85.86	2.92	88.59	2.94	89.04	2.99
	44	68.91	2.30	80.57	2.88	82.77	2.91	83.98	2.92	85.20	2.93	87.05	2.95	87.66	3.05
46	68.91	2.33	80.13	2.91	81.98	2.94	83.10	2.95	84.45	2.96	85.29	2.96	86.78	3.11	
110%	10	63.14	1.01	75.29	1.24	87.43	1.47	93.50	1.59	99.57	1.71	107.17	1.81	109.60	1.75
	12	63.14	1.04	75.29	1.26	87.43	1.50	93.50	1.62	99.57	1.74	105.95	1.81	108.07	1.74
	14	63.14	1.05	75.29	1.28	87.43	1.53	93.50	1.65	99.57	1.77	104.43	1.80	106.86	1.74
	16	63.14	1.07	75.29	1.31	87.43	1.56	93.50	1.68	99.57	1.81	103.22	1.82	105.34	1.84
	18	63.14	1.09	75.29	1.33	87.43	1.59	93.50	1.73	99.57	1.90	101.70	1.91	104.13	1.93
	20	63.14	1.11	75.29	1.36	87.43	1.68	93.50	1.86	98.05	1.99	100.49	2.00	102.61	2.02
	21	63.14	1.13	75.29	1.40	87.43	1.74	93.50	1.93	97.45	2.04	99.58	2.05	102.00	2.07
	23	63.14	1.18	75.29	1.50	87.43	1.87	93.50	2.07	95.94	2.13	98.37	2.15	100.49	2.17
	25	63.14	1.26	75.29	1.61	87.43	2.00	93.50	2.21	94.72	2.22	96.84	2.24	99.27	2.26
	27	63.14	1.34	75.29	1.72	87.43	2.14	91.99	2.31	93.20	2.31	95.63	2.33	97.75	2.36
	29	63.14	1.43	75.29	1.83	87.43	2.28	90.77	2.40	91.99	2.41	94.11	2.43	96.54	2.45
	31	63.14	1.52	75.29	1.95	87.43	2.44	89.26	2.49	90.47	2.50	92.90	2.52	95.02	2.55
	33	63.14	1.62	75.29	2.08	86.82	2.57	88.04	2.58	89.26	2.60	91.38	2.62	93.81	2.65
	35	63.14	1.72	75.29	2.22	85.31	2.66	86.52	2.68	87.73	2.69	89.86	2.72	92.29	2.74
	37	63.14	1.84	75.29	2.36	84.09	2.76	85.31	2.77	86.22	2.79	88.65	2.81	90.77	2.84
	39	63.14	1.95	75.29	2.52	82.58	2.85	83.79	2.87	85.01	2.88	87.13	2.91	89.56	2.94
	42	63.14	1.97	75.29	2.54	81.93	2.87	83.14	2.89	84.36	2.90	86.02	2.93	86.86	2.96
	44	63.14	1.99	75.29	2.57	81.28	2.89	82.49	2.91	83.71	2.92	85.25	2.94	85.53	3.02
46	63.14	2.05	75.29	2.58	80.46	2.92	81.62	2.94	82.96	2.95	84.39	3.02	84.73	3.09	
100%	10	57.38	0.92	68.31	1.11	79.53	1.32	85.00	1.42	90.47	1.53	101.69	1.75	107.47	1.81
	12	57.38	0.93	68.31	1.13	79.53	1.34	85.00	1.45	90.47	1.56	101.69	1.78	105.94	1.80

	14	57.38	0.95	68.31	1.15	79.53	1.37	85.00	1.48	90.47	1.59	101.69	1.82	104.73	1.79
	16	57.38	0.97	68.31	1.18	79.53	1.39	85.00	1.51	90.47	1.62	101.09	1.84	103.22	1.82
	18	57.38	0.99	68.31	1.20	79.53	1.42	85.00	1.53	90.47	1.65	99.88	1.90	102.00	1.91
	20	57.38	1.00	68.31	1.22	79.53	1.46	85.00	1.61	90.47	1.77	98.35	1.99	100.48	2.01
	21	57.38	1.01	68.31	1.23	79.53	1.52	85.00	1.67	90.47	1.83	97.75	2.04	99.88	2.05
	23	57.38	1.04	68.31	1.32	79.53	1.62	85.00	1.79	90.47	1.96	96.53	2.13	98.35	2.15
	25	57.38	1.11	68.31	1.41	79.53	1.74	85.00	1.92	90.47	2.10	95.02	2.22	97.14	2.24
	27	57.38	1.18	68.31	1.50	79.53	1.86	85.00	2.05	90.47	2.25	93.50	2.32	95.63	2.34
	29	57.38	1.26	68.31	1.60	79.53	1.98	85.00	2.19	90.16	2.39	92.28	2.41	94.41	2.43
	31	57.38	1.34	68.31	1.71	79.53	2.11	85.00	2.34	88.94	2.48	90.77	2.51	92.89	2.53
	33	57.38	1.42	68.31	1.82	79.53	2.25	85.00	2.50	87.43	2.58	89.56	2.60	91.68	2.62
	35	57.38	1.51	68.31	1.93	79.53	2.41	85.00	2.66	85.91	2.67	88.03	2.70	90.16	2.72
	37	57.38	1.61	68.31	2.06	79.53	2.56	83.47	2.75	84.69	2.77	86.82	2.79	88.65	2.81
	39	57.38	1.71	68.31	2.19	79.53	2.73	82.26	2.85	83.17	2.86	85.31	2.89	87.43	2.91
	42	57.38	1.79	68.31	2.27	79.53	2.83	80.99	2.87	82.54	2.90	83.82	2.95	86.16	2.97
	44	57.38	1.87	68.31	2.35	79.53	2.88	79.71	2.90	81.94	2.93	84.32	2.97	84.64	3.01
	46	57.38	1.98	68.31	2.45	79.53	2.93	78.01	2.94	81.52	2.99	83.61	3.02	82.94	3.05
90%	10	51.61	0.82	61.63	0.99	71.64	1.17	76.50	1.26	81.36	1.35	91.37	1.55	101.39	1.75
	12	51.61	0.84	61.63	1.01	71.64	1.19	76.50	1.28	81.36	1.38	91.37	1.58	101.39	1.78
	14	51.61	0.85	61.63	1.03	71.64	1.21	76.50	1.31	81.36	1.41	91.37	1.61	101.39	1.81
	16	51.61	0.86	61.63	1.04	71.64	1.24	76.50	1.33	81.36	1.43	91.37	1.64	101.09	1.84
	18	51.61	0.88	61.63	1.06	71.64	1.26	76.50	1.36	81.36	1.46	91.37	1.67	99.88	1.90
	20	51.61	0.90	61.63	1.09	71.64	1.28	76.50	1.39	81.36	1.52	91.37	1.80	98.36	1.99
	21	51.61	0.90	61.63	1.10	71.64	1.30	76.50	1.43	81.36	1.57	91.37	1.86	97.75	2.04
	23	51.61	0.92	61.63	1.14	71.64	1.40	76.50	1.54	81.36	1.68	91.37	2.00	96.23	2.13
	25	51.61	0.97	61.63	1.22	71.64	1.49	76.50	1.65	81.36	1.80	91.37	2.14	95.02	2.22
	27	51.61	1.03	61.63	1.30	71.64	1.60	76.50	1.76	81.36	1.92	91.37	2.29	93.50	2.32
	29	51.61	1.10	61.63	1.38	71.64	1.70	76.50	1.87	81.36	2.06	90.46	2.39	92.28	2.41
	31	51.61	1.17	61.63	1.47	71.64	1.81	76.50	2.00	81.36	2.19	88.95	2.48	90.77	2.51
	33	51.61	1.24	61.63	1.57	71.64	1.94	76.50	2.13	81.36	2.34	87.73	2.58	89.55	2.60
	35	51.61	1.32	61.63	1.67	71.64	2.06	76.50	2.27	81.36	2.49	86.22	2.67	88.04	2.70
	37	51.61	1.40	61.63	1.77	71.64	2.19	76.50	2.42	81.36	2.66	84.69	2.77	86.82	2.79
	39	51.61	1.48	61.63	1.89	71.64	2.33	76.50	2.58	81.36	2.83	83.48	2.86	85.31	2.89
42	51.61	1.54	61.63	1.97	71.64	2.42	76.50	2.65	81.36	2.85	82.90	2.94	84.73	2.95	
44	51.61	1.61	61.63	2.06	71.64	2.50	76.50	2.71	81.36	2.91	82.48	2.98	84.00	3.00	
46	51.61	1.71	61.63	2.16	71.64	2.61	76.50	2.80	81.36	2.99	82.02	3.01	82.72	3.04	
80%	10	45.84	0.73	54.64	0.87	63.44	1.03	68.00	1.10	72.56	1.18	81.36	1.35	90.16	1.52
	12	45.84	0.74	54.64	0.89	63.44	1.04	68.00	1.13	72.56	1.21	81.36	1.38	90.16	1.55
	14	45.84	0.75	54.64	0.90	63.44	1.06	68.00	1.14	72.56	1.23	81.36	1.40	90.16	1.58
	16	45.84	0.76	54.64	0.92	63.44	1.08	68.00	1.17	72.56	1.25	81.36	1.43	90.16	1.61
	18	45.84	0.78	54.64	0.94	63.44	1.10	68.00	1.19	72.56	1.28	81.36	1.46	90.16	1.64
	20	45.84	0.79	54.64	0.95	63.44	1.13	68.00	1.21	72.56	1.30	81.36	1.51	90.16	1.76
	21	45.84	0.80	54.64	0.96	63.44	1.14	68.00	1.23	72.56	1.33	81.36	1.57	90.16	1.82
	23	45.84	0.81	54.64	0.98	63.44	1.19	68.00	1.30	72.56	1.42	81.36	1.68	90.16	1.95
	25	45.84	0.84	54.64	1.04	63.44	1.27	68.00	1.39	72.56	1.52	81.36	1.80	90.16	2.09
	27	45.84	0.89	54.64	1.11	63.44	1.36	68.00	1.49	72.56	1.62	81.36	1.92	90.16	2.24
	29	45.84	0.95	54.64	1.18	63.44	1.44	68.00	1.58	72.56	1.74	81.36	2.05	90.16	2.39
	31	45.84	1.01	54.64	1.26	63.44	1.54	68.00	1.69	72.56	1.85	81.36	2.19	88.64	2.48
	33	45.84	1.07	54.64	1.34	63.44	1.64	68.00	1.80	72.56	1.97	81.36	2.33	87.43	2.58
	35	45.84	1.14	54.64	1.42	63.44	1.74	68.00	1.91	72.56	2.10	81.36	2.48	85.91	2.67
	37	45.84	1.20	54.64	1.51	63.44	1.85	68.00	2.04	72.56	2.23	81.36	2.65	84.69	2.76
	39	45.84	1.28	54.64	1.61	63.44	1.97	68.00	2.17	72.56	2.38	81.36	2.82	83.18	2.86
42	45.84	1.31	54.64	1.62	63.44	2.00	68.00	2.23	72.56	2.42	81.36	2.89	82.67	2.91	
44	45.84	1.34	54.64	1.64	63.44	2.03	68.00	2.26	72.56	2.45	81.36	2.93	82.16	2.94	
46	45.84	1.38	54.64	1.66	63.44	2.07	68.00	2.31	72.56	2.50	81.36	2.96	81.14	2.99	
70%	10	40.07	0.64	47.96	0.76	55.56	0.89	59.50	0.95	63.44	1.02	71.04	1.16	78.93	1.30
	12	40.07	0.65	47.96	0.77	55.56	0.90	59.50	0.97	63.44	1.04	71.04	1.18	78.93	1.33
	14	40.07	0.66	47.96	0.79	55.56	0.92	59.50	0.99	63.44	1.06	71.04	1.20	78.93	1.36
	16	40.07	0.67	47.96	0.80	55.56	0.94	59.50	1.01	63.44	1.08	71.04	1.23	78.93	1.38
	18	40.07	0.68	47.96	0.81	55.56	0.95	59.50	1.03	63.44	1.10	71.04	1.25	78.93	1.41
	20	40.07	0.69	47.96	0.83	55.56	0.97	59.50	1.04	63.44	1.12	71.04	1.28	78.93	1.45
	21	40.07	0.70	47.96	0.84	55.56	0.98	59.50	1.05	63.44	1.13	71.04	1.29	78.93	1.50
	23	40.07	0.71	47.96	0.85	55.56	1.00	59.50	1.09	63.44	1.19	71.04	1.39	78.93	1.61
25	40.07	0.72	47.96	0.89	55.56	1.06	59.50	1.17	63.44	1.27	71.04	1.48	78.93	1.72	

	27	40.07	0.77	47.96	0.94	55.56	1.14	59.50	1.24	63.44	1.35	71.04	1.58	78.93	1.84
	29	40.07	0.81	47.96	1.00	55.56	1.21	59.50	1.32	63.44	1.44	71.04	1.69	78.93	1.96
	31	40.07	0.86	47.96	1.06	55.56	1.29	59.50	1.41	63.44	1.53	71.04	1.80	78.93	2.09
	33	40.07	0.91	47.96	1.13	55.56	1.37	59.50	1.49	63.44	1.63	71.04	1.92	78.93	2.23
	35	40.07	0.97	47.96	1.20	55.56	1.45	59.50	1.59	63.44	1.74	71.04	2.04	78.93	2.38
	37	40.07	1.02	47.96	1.27	55.56	1.55	59.50	1.69	63.44	1.85	71.04	2.18	78.93	2.53
	39	40.07	1.08	47.96	1.34	55.56	1.64	59.50	1.80	63.44	1.96	71.04	2.31	78.93	2.70
	42	40.07	1.13	47.96	1.39	55.56	1.69	59.50	1.86	63.44	2.02	71.04	2.41	78.93	2.82
	44	40.07	1.22	47.96	1.49	55.56	1.76	59.50	1.96	63.44	2.08	71.04	2.50	78.93	2.90
46	40.07	1.25	47.96	1.52	55.56	1.79	59.50	1.99	63.44	2.18	71.04	2.63	78.93	3.01	
60%	10	34.30	0.56	40.98	0.65	47.66	0.76	51.00	0.81	54.34	0.86	61.02	0.98	67.70	1.10
	12	34.30	0.57	40.98	0.66	47.66	0.77	51.00	0.82	54.34	0.88	61.02	1.00	67.70	1.11
	14	34.30	0.57	40.98	0.67	47.66	0.78	51.00	0.84	54.34	0.90	61.02	1.01	67.70	1.14
	16	34.30	0.58	40.98	0.68	47.66	0.80	51.00	0.85	54.34	0.91	61.02	1.03	67.70	1.16
	18	34.30	0.59	40.98	0.70	47.66	0.81	51.00	0.87	54.34	0.93	61.02	1.05	67.70	1.18
	20	34.30	0.60	40.98	0.71	47.66	0.82	51.00	0.89	54.34	0.95	61.02	1.07	67.70	1.20
	21	34.30	0.61	40.98	0.71	47.66	0.83	51.00	0.89	54.34	0.95	61.02	1.08	67.70	1.22
	23	34.30	0.61	40.98	0.73	47.66	0.85	51.00	0.91	54.34	0.97	61.02	1.13	67.70	1.29
	25	34.30	0.62	40.98	0.74	47.66	0.88	51.00	0.95	54.34	1.03	61.02	1.20	67.70	1.38
	27	34.30	0.65	40.98	0.79	47.66	0.94	51.00	1.02	54.34	1.10	61.02	1.28	67.70	1.47
	29	34.30	0.68	40.98	0.83	47.66	1.00	51.00	1.08	54.34	1.17	61.02	1.37	67.70	1.57
	31	34.30	0.73	40.98	0.88	47.66	1.06	51.00	1.15	54.34	1.25	61.02	1.45	67.70	1.67
	33	34.30	0.77	40.98	0.94	47.66	1.12	51.00	1.22	54.34	1.33	61.02	1.54	67.70	1.79
	35	34.30	0.81	40.98	0.99	47.66	1.19	51.00	1.30	54.34	1.41	61.02	1.65	67.70	1.90
	37	34.30	0.86	40.98	1.05	47.66	1.26	51.00	1.38	54.34	1.49	61.02	1.75	67.70	2.02
	39	34.30	0.91	40.98	1.11	47.66	1.34	51.00	1.46	54.34	1.59	61.02	1.86	67.70	2.15
42	34.30	0.94	40.98	1.16	47.66	1.39	51.00	1.52	54.34	1.65	61.02	1.94	67.70	2.25	
44	34.30	0.97	40.98	1.21	47.66	1.43	51.00	1.56	54.34	1.70	61.02	2.03	67.70	2.35	
46	34.30	1.01	40.98	1.27	47.66	1.49	51.00	1.62	54.34	1.79	61.02	2.12	67.70	2.48	
50%	10	28.69	0.48	34.30	0.56	39.77	0.63	42.50	0.68	45.23	0.72	50.70	0.81	56.47	0.90
	12	28.69	0.48	34.30	0.56	39.77	0.65	42.50	0.68	45.23	0.73	50.70	0.82	56.47	0.91
	14	28.69	0.49	34.30	0.57	39.77	0.65	42.50	0.70	45.23	0.74	50.70	0.84	56.47	0.93
	16	28.69	0.50	34.30	0.58	39.77	0.66	42.50	0.71	45.23	0.75	50.70	0.85	56.47	0.95
	18	28.69	0.51	34.30	0.59	39.77	0.67	42.50	0.72	45.23	0.77	50.70	0.86	56.47	0.96
	20	28.69	0.51	34.30	0.60	39.77	0.68	42.50	0.73	45.23	0.78	50.70	0.88	56.47	0.98
	21	28.69	0.52	34.30	0.60	39.77	0.69	42.50	0.74	45.23	0.79	50.70	0.89	56.47	0.99
	23	28.69	0.52	34.30	0.61	39.77	0.70	42.50	0.75	45.23	0.80	50.70	0.90	56.47	1.01
	25	28.69	0.53	34.30	0.62	39.77	0.72	42.50	0.77	45.23	0.83	50.70	0.95	56.47	1.08
	27	28.69	0.54	34.30	0.65	39.77	0.76	42.50	0.82	45.23	0.88	50.70	1.01	56.47	1.15
	29	28.69	0.57	34.30	0.68	39.77	0.80	42.50	0.87	45.23	0.94	50.70	1.08	56.47	1.23
	31	28.69	0.60	34.30	0.72	39.77	0.85	42.50	0.92	45.23	0.99	50.70	1.14	56.47	1.31
	33	28.69	0.64	34.30	0.76	39.77	0.90	42.50	0.97	45.23	1.05	50.70	1.22	56.47	1.39
	35	28.69	0.67	34.30	0.81	39.77	0.95	42.50	1.03	45.23	1.11	50.70	1.29	56.47	1.48
	37	28.69	0.71	34.30	0.85	39.77	1.01	42.50	1.09	45.23	1.18	50.70	1.37	56.47	1.57
	39	28.69	0.75	34.30	0.90	39.77	1.07	42.50	1.16	45.23	1.25	50.70	1.45	56.47	1.67
42	28.69	0.78	34.30	0.94	39.77	1.11	42.50	1.21	45.23	1.31	50.70	1.53	56.47	1.74	
44	28.69	0.83	34.30	1.00	39.77	1.15	42.50	1.27	45.23	1.34	50.70	1.61	56.47	1.82	
46	28.69	0.85	34.30	1.03	39.77	1.22	42.50	1.36	45.23	1.40	50.70	1.76	56.47	1.98	

Note:

- 1, [] is shown as reference
- 2, In heating mode, avoid the outdoor air temperature range from -15 to -20 degree C, when selecting the models
- 3, The above table shows the average value of conditions may operate
- 4, It is recommended to connect less than 130%

30HP heating mode

Combination (Capacity index)	Outdoor air temp.		Indoor temperature(°C DB)											
			16		18		20		21		22		24	
			TC	PI	TC	PI	TC	PI	TC	PI	TC	PI	TC	PI
°C DB	°C WB	kW	kW	kW	kW	kW	kW	kW	kW	kW	kW	kW	kW	
130%	-19.8	-20	61.52	1.72	61.22	1.84	60.92	1.97	60.92	2.03	60.62	2.09	60.62	2.21
	-18.8	-19	62.43	1.76	62.13	1.88	62.13	2.00	61.82	2.06	61.82	2.12	61.52	2.24
	-16.7	-17	64.84	1.84	64.54	1.96	64.23	2.08	64.23	2.13	64.23	2.19	63.94	2.30
	-13.7	-15	67.55	1.93	67.26	2.04	66.95	2.15	66.95	2.21	66.65	2.26	66.65	2.37
	-11.8	-13	70.27	2.02	70.27	2.12	69.97	2.23	69.66	2.28	69.66	2.34	69.36	2.44
	-9.8	-11	73.59	2.10	73.29	2.21	72.98	2.31	72.98	2.36	72.98	2.41	72.68	2.51
	-9.5	-10	75.39	2.15	75.10	2.25	74.79	2.34	74.79	2.40	74.49	2.44	74.49	2.54
	-8.5	-9.1	76.90	2.19	76.61	2.28	76.61	2.38	76.30	2.43	76.30	2.47	76.00	2.57
	-7	-7.6	79.62	2.25	79.62	2.34	79.32	2.44	79.32	2.48	79.01	2.53	78.71	2.62
	-5	-5.6	83.84	2.34	83.53	2.42	83.23	2.51	83.23	2.56	82.94	2.60	82.94	2.69
	-3	-3.7	87.76	2.41	87.46	2.50	87.46	2.58	87.16	2.62	87.16	2.66	86.85	2.75
	0	-0.7	94.69	2.53	94.69	2.61	94.39	2.68	94.39	2.71	94.10	2.76	94.10	2.84
	3	2.2	102.23	2.63	101.94	2.71	101.63	2.78	101.63	2.81	101.63	2.85	101.33	2.92
	5	4.1	107.36	2.70	107.06	2.77	107.06	2.84	106.76	2.87	106.76	2.91	106.46	2.97
	7	6	112.79	2.76	112.49	2.83	112.49	2.89	112.19	2.92	112.19	2.96	107.66	2.84
9	7.9	118.52	2.82	118.22	2.88	118.22	2.94	117.92	2.98	115.50	2.91	107.66	2.67	
11	9.8	124.55	2.88	124.26	2.93	123.65	2.97	119.43	2.86	115.50	2.74	107.66	2.51	
13	11.8	131.19	2.93	130.88	2.99	123.65	2.79	119.43	2.67	115.50	2.57	107.66	2.36	
15	13.7	137.52	2.98	131.49	2.83	123.65	2.62	119.43	2.52	115.50	2.42	107.66	2.22	
120%	-19.8	-20	61.22	1.89	60.92	2.00	60.62	2.11	60.62	2.17	60.62	2.22	60.32	2.34
	-18.8	-19	62.13	1.92	61.83	2.03	61.83	2.15	61.53	2.20	61.53	2.26	61.22	2.37
	-16.7	-17	64.55	2.00	64.24	2.11	63.84	2.21	63.94	2.27	63.94	2.32	63.64	2.42
	-13.7	-15	67.26	2.08	66.96	2.18	66.66	2.28	66.66	2.34	66.66	2.39	66.35	2.49
	-11.8	-13	69.98	2.16	69.98	2.26	69.67	2.35	69.67	2.41	69.37	2.45	69.37	2.55
	-9.8	-11	73.29	2.24	72.98	2.33	72.98	2.43	72.68	2.47	72.68	2.52	72.39	2.61
	-9.5	-10	75.10	2.28	74.80	2.37	74.50	2.46	74.50	2.51	74.50	2.55	74.19	2.65
	-8.5	-9.1	76.61	2.32	76.30	2.41	76.30	2.49	76.00	2.54	76.00	2.59	75.70	2.67
	-7	-7.6	79.32	2.38	79.32	2.46	79.02	2.55	79.02	2.59	78.72	2.63	78.72	2.72
	-5	-5.6	83.54	2.45	83.24	2.54	82.93	2.62	82.93	2.66	82.93	2.70	82.64	2.78
	-3	-3.7	87.47	2.53	87.47	2.60	87.16	2.68	87.16	2.72	86.86	2.76	86.86	2.84
	0	-0.7	94.40	2.63	94.40	2.71	94.10	2.78	94.10	2.81	93.80	2.85	93.80	2.92
	3	2.2	101.94	2.73	101.64	2.80	101.64	2.86	101.33	2.90	101.33	2.93	99.23	2.92
	5	4.1	107.07	2.79	106.76	2.86	106.76	2.92	106.46	2.95	106.46	2.98	99.23	2.74
	7	6	112.50	2.85	112.50	2.91	112.20	2.97	110.39	2.93	106.76	2.81	99.23	2.58
9	7.9	118.23	2.91	117.93	2.96	114.00	2.86	110.39	2.75	106.76	2.64	99.23	2.42	
11	9.8	124.26	2.96	121.24	2.91	114.00	2.69	110.39	2.59	106.76	2.48	99.23	2.28	
13	11.8	128.78	2.93	121.24	2.73	114.00	2.53	110.39	2.43	106.76	2.34	99.23	2.15	
15	13.7	128.78	2.76	121.24	2.57	114.00	2.38	110.39	2.29	106.76	2.20	99.23	2.03	
110%	-19.8	-20	60.92	2.05	60.62	2.15	60.32	2.26	60.32	2.31	60.34	2.36	60.02	2.47
	-18.8	-19	61.83	2.09	61.52	2.19	61.52	2.29	61.52	2.34	61.22	2.39	61.22	2.49
	-16.7	-17	64.24	2.15	63.94	2.25	64.83	2.35	63.64	2.40	63.64	2.45	63.34	2.54
	-13.7	-15	66.96	2.23	66.66	2.32	66.35	2.41	66.35	2.46	66.35	2.51	66.05	2.60
	-11.8	-13	69.67	2.30	69.67	2.39	69.36	2.48	69.36	2.53	69.06	2.57	69.06	2.66
	-9.8	-11	72.98	2.38	72.68	2.46	72.68	2.55	72.38	2.59	72.38	2.63	72.38	2.72
	-9.5	-10	74.79	2.41	74.49	2.50	74.19	2.58	74.19	2.62	74.19	2.67	73.89	2.75
	-8.5	-9.1	76.30	2.45	76.00	2.53	76.00	2.61	75.69	2.65	75.69	2.69	75.69	2.46
	-7	-7.6	79.01	2.50	79.01	2.58	78.72	2.66	78.72	2.70	78.72	2.74	78.42	2.82
	-5	-5.6	83.24	2.57	82.94	2.65	82.63	2.72	82.63	2.76	82.63	2.80	82.33	2.87
	-3	-3.7	87.16	2.64	87.16	2.71	86.86	2.78	86.86	2.82	86.56	2.85	86.56	2.92
	0	-0.7	94.09	2.74	94.09	2.80	93.80	2.87	93.80	2.90	93.80	2.94	91.08	2.88
	3	2.2	101.64	2.83	101.33	2.89	101.33	2.95	101.03	2.98	97.71	2.86	91.08	2.62
	5	4.1	106.77	2.88	106.77	2.94	104.65	2.92	101.03	2.80	97.71	2.69	91.08	2.47
	7	6	112.19	2.94	111.29	2.96	104.65	2.74	101.03	2.63	97.71	2.53	91.08	2.32
9	7.9	117.92	2.99	111.29	2.78	104.65	2.58	101.03	2.47	97.71	2.38	91.08	2.19	
11	9.8	117.92	2.81	111.29	2.61	104.65	2.42	101.03	2.33	97.71	2.24	91.08	2.06	
13	11.8	117.92	2.63	111.29	2.45	104.65	2.28	101.03	2.19	97.71	2.11	91.08	1.94	
15	13.7	117.92	2.34	111.29	2.31	104.65	2.15	101.03	2.07	97.71	1.99	91.08	1.84	
100%	-19.8	-20	60.62	2.22	60.32	2.31	60.32	2.41	60.01	2.45	60.01	2.50	59.72	2.59
	-18.8	-19	61.52	2.25	61.52	2.34	61.22	2.43	61.22	2.48	60.92	2.53	60.92	2.62

	-16.7	-17	63.94	2.31	63.63	2.40	63.63	2.49	63.34	2.53	63.34	2.58	63.34	2.66
	-13.7	-15	66.65	2.38	66.35	2.46	66.04	2.55	66.04	2.59	66.04	2.63	65.75	2.72
	-11.8	-13	69.37	2.45	69.37	2.53	69.07	2.61	69.07	2.65	69.07	2.69	68.76	2.77
	-9.8	-11	72.68	2.51	72.38	2.59	72.38	2.67	72.38	2.71	72.08	2.75	72.08	2.82
	-9.5	-10	74.49	2.55	74.20	2.62	74.20	2.70	73.89	2.74	73.89	2.78	73.59	2.85
	-8.5	-9.1	76.00	2.58	75.70	2.65	75.70	2.73	75.70	2.76	75.40	2.80	75.40	2.87
	-7	-7.6	78.72	2.63	78.72	2.70	78.41	2.77	78.41	2.81	78.41	2.84	78.11	2.92
	-5	-5.6	82.94	2.69	82.63	2.76	82.63	2.83	82.34	2.86	82.34	2.90	82.03	2.97
	-3	-3.7	86.86	2.75	86.86	2.80	86.55	2.88	86.55	2.92	86.55	2.95	86.24	3.02
	0	-0.7	93.79	2.84	93.79	2.90	93.49	2.96	91.99	2.92	88.97	2.80	82.94	2.56
	3	2.2	101.34	2.92	101.03	2.98	95.00	2.76	91.99	2.65	88.97	2.54	82.94	2.34
	5	4.1	106.46	2.98	101.03	2.80	95.00	2.59	91.99	2.49	88.97	2.40	82.94	2.20
	7	6	107.07	2.83	101.03	2.63	95.00	2.44	91.99	2.35	88.97	2.26	82.94	2.08
	9	7.9	107.07	2.66	101.03	2.47	95.00	2.30	91.99	2.18	88.97	2.13	82.94	1.96
	11	9.8	107.07	2.50	101.03	2.33	95.00	2.17	91.99	2.08	88.97	2.01	82.94	1.85
	13	11.8	107.07	2.35	101.03	2.19	95.00	2.04	91.99	1.96	88.97	1.89	82.94	1.75
	15	13.7	107.07	2.22	101.03	2.07	95.00	1.93	91.99	1.86	88.97	1.79	82.94	1.65
90%	-19.8	-20	60.21	2.38	59.91	2.47	59.91	2.55	59.61	2.59	59.61	2.64	59.61	2.72
	-18.8	-19	61.12	2.41	61.12	2.49	60.82	2.58	60.82	2.62	60.82	2.66	60.51	2.74
	-16.7	-17	63.53	2.47	63.22	2.55	63.22	2.63	63.22	2.67	62.92	2.71	62.92	2.79
	-13.7	-15	66.23	2.53	65.93	2.60	65.93	2.68	65.63	2.72	65.63	2.76	65.63	2.83
	-11.8	-13	68.94	2.59	68.94	2.66	68.64	2.73	68.64	2.77	68.64	2.81	68.34	2.88
	-9.8	-11	72.26	2.65	72.26	2.72	71.95	2.79	71.95	2.82	71.95	2.86	71.65	2.93
	-9.5	-10	74.06	2.68	73.76	2.75	73.76	2.82	73.46	2.85	73.46	2.89	73.46	2.95
	-8.5	-9.1	75.56	2.71	75.56	2.78	75.27	2.84	75.27	2.87	75.27	2.91	74.36	2.94
	-7	-7.6	78.28	2.75	78.28	2.82	77.98	2.88	77.98	2.92	77.98	2.95	74.36	2.80
	-5	-5.6	82.49	2.81	82.19	2.87	82.19	2.93	81.88	2.97	79.78	2.87	74.36	2.64
	-3	-3.7	86.41	2.87	86.41	2.92	85.50	2.94	82.49	2.82	79.78	2.71	74.36	2.48
	0	-0.7	93.63	2.95	90.92	2.88	85.50	2.67	82.49	2.56	79.78	2.46	74.36	2.26
	3	2.2	96.34	2.81	90.92	2.62	85.50	2.43	82.49	2.34	79.78	2.24	74.36	2.07
	5	4.1	96.34	2.64	90.92	2.46	85.50	2.29	82.49	2.20	79.78	2.12	74.36	1.95
	7	6	96.34	2.48	90.92	2.32	85.50	2.15	82.49	2.08	79.78	2.00	74.36	1.84
9	7.9	96.34	2.34	90.92	2.18	85.50	2.03	82.49	1.96	79.78	1.89	74.36	1.74	
11	9.8	96.34	2.21	90.92	2.06	85.50	1.92	82.49	1.85	79.78	1.78	74.36	1.65	
13	11.8	96.34	2.08	90.92	1.94	85.50	1.81	82.49	1.75	79.78	1.68	74.36	1.56	
15	13.7	96.34	1.96	90.92	1.83	85.50	1.71	82.49	1.65	79.78	1.59	74.36	1.48	
80%	-19.8	-20	60.02	2.55	59.71	2.62	59.71	2.70	59.71	2.73	59.41	2.77	59.41	2.85
	-18.8	-19	60.92	2.57	60.92	2.65	60.62	2.72	60.62	2.76	60.62	2.79	60.32	2.87
	-16.7	-17	63.33	2.62	63.03	2.69	63.03	2.77	63.03	2.80	63.03	2.84	62.73	2.91
	-13.7	-15	66.04	2.68	65.75	2.74	65.75	2.81	65.75	2.85	65.44	2.88	65.44	2.95
	-11.8	-13	68.76	2.73	68.76	2.80	68.46	2.86	68.46	2.89	68.46	2.93	66.35	2.85
	-9.8	-11	72.08	2.79	72.08	2.85	71.77	2.91	71.77	2.94	71.17	2.93	66.35	2.69
	-9.5	-10	73.89	2.81	73.58	2.87	73.59	2.93	73.59	2.97	71.17	2.85	66.35	2.61
	-8.5	-9.1	75.40	2.84	70.08	2.90	75.10	2.96	73.59	2.89	71.17	2.77	66.35	2.54
	-7	-7.6	78.11	2.88	78.11	2.94	76.00	2.87	73.59	2.76	71.17	2.65	66.35	2.43
	-5	-5.6	82.33	2.93	80.83	2.92	76.00	2.70	73.59	2.60	71.17	2.49	66.35	2.29
	-3	-3.7	85.65	2.95	80.83	2.74	76.00	2.54	73.59	2.45	71.17	2.35	66.35	2.16
	0	-0.7	85.65	2.67	80.83	2.49	76.00	2.31	73.59	2.23	71.17	2.14	66.35	1.97
	3	2.2	85.65	2.44	80.83	2.27	76.00	2.11	73.59	2.03	71.17	1.96	66.35	1.81
	5	4.1	85.65	2.29	80.83	2.14	76.00	1.99	73.59	1.92	71.17	1.85	66.35	1.71
	7	6	85.65	2.16	80.83	2.02	76.00	1.88	73.59	1.82	71.17	1.75	66.35	1.62
9	7.9	85.65	2.04	80.83	1.91	76.00	1.78	73.59	1.71	71.17	1.65	66.35	1.53	
11	9.8	85.65	1.93	80.83	1.80	76.00	1.68	73.59	1.62	71.17	1.57	66.35	1.45	
13	11.8	85.65	1.82	80.83	1.70	76.00	1.59	73.59	1.53	71.17	1.48	66.35	1.37	
15	13.7	85.65	1.72	80.83	1.61	76.00	1.51	73.59	1.45	71.17	1.40	66.35	1.31	
70%	-19.8	-20	59.58	2.71	59.28	2.78	59.28	2.84	59.28	2.87	59.28	2.91	57.78	2.88
	-18.8	-19	60.48	2.73	60.48	2.80	60.18	2.86	60.18	2.89	60.18	2.93	57.78	2.82
	-16.7	-17	62.89	2.78	62.89	2.84	62.59	2.90	62.59	2.93	61.98	2.61	57.78	2.69
	-13.7	-15	65.60	2.83	65.30	2.89	65.30	2.95	64.09	2.90	61.98	2.79	57.78	2.55
	-11.8	-13	68.30	2.87	68.30	2.93	66.50	2.86	64.09	2.75	61.98	2.64	57.78	2.42
	-9.8	-11	71.61	2.92	70.71	2.92	66.50	2.70	64.09	2.60	61.98	2.49	57.78	2.29
	-9.5	-10	73.42	2.95	70.71	2.83	66.50	2.62	64.09	2.52	61.98	2.42	57.78	2.23
	-8.5	-9.1	74.93	2.96	70.71	2.76	66.50	2.55	64.09	2.46	61.98	2.36	57.78	2.17
-7	-7.6	74.93	2.83	70.71	2.63	66.50	2.44	64.09	2.35	61.98	2.26	57.78	2.08	

	-5	-5.6	74.93	2.66	70.71	2.48	66.50	2.30	64.09	2.21	61.98	2.61	57.78	1.96
	-3	-3.7	74.93	2.50	70.71	2.34	66.50	2.17	64.09	2.09	61.98	2.01	57.78	1.85
	0	-0.7	74.93	2.28	70.71	2.13	66.50	1.98	64.09	1.91	61.98	1.84	57.78	1.70
	3	2.2	74.93	2.08	70.71	1.95	66.50	1.82	64.09	1.75	61.98	1.69	57.78	1.56
	5	4.1	74.93	1.96	70.71	1.84	66.50	1.72	64.09	1.65	61.98	1.59	57.78	1.48
	7	6	74.93	1.86	70.71	1.74	66.50	1.62	64.09	1.57	61.98	1.51	57.78	1.40
	9	7.9	74.93	1.76	70.71	1.64	66.50	1.54	64.09	1.48	61.98	1.43	57.78	1.33
	11	9.8	74.93	1.66	70.71	1.56	66.50	1.46	64.09	1.41	61.98	1.36	57.78	1.26
	13	11.8	74.93	1.57	70.71	1.47	66.50	1.38	64.09	1.33	61.98	1.29	57.78	1.20
	15	13.7	74.93	1.49	70.71	1.40	66.50	1.31	64.09	1.27	61.98	1.22	57.78	1.14
60%	-19.8	-20	59.41	2.88	59.11	2.93	57.00	2.82	55.19	2.71	53.38	2.60	49.76	2.39
	-18.8	-19	60.32	2.90	60.32	2.95	57.00	2.76	55.19	2.65	53.38	2.54	49.76	2.34
	-16.7	-17	62.73	2.93	60.62	2.84	57.00	2.63	55.19	2.53	53.38	2.43	49.76	2.23
	-13.7	-15	64.24	2.90	60.62	2.70	57.00	2.50	55.19	2.41	53.38	2.31	49.76	2.13
	-11.8	-13	64.24	2.75	60.62	2.56	57.00	2.37	55.19	2.28	53.38	2.20	49.76	2.03
	-9.8	-11	64.24	2.60	60.62	2.42	57.00	2.25	55.19	2.16	53.38	2.08	49.76	1.92
	-9.5	-10	64.24	2.52	60.62	2.35	57.00	2.18	55.19	2.10	53.38	2.02	49.76	1.86
	-8.5	-9.1	64.24	2.46	60.62	2.29	57.00	2.13	55.19	2.05	53.38	1.97	49.76	1.82
	-7	-7.6	64.24	2.35	60.62	2.19	57.00	2.04	55.19	1.96	53.38	1.89	49.76	1.75
	-5	-5.6	64.24	2.21	60.62	2.07	57.00	1.92	55.19	1.85	53.38	1.78	49.76	1.65
	-3	-3.7	64.24	2.09	60.62	1.95	57.00	1.82	55.19	1.76	53.38	1.69	49.76	1.56
	0	-0.7	64.24	1.91	60.62	1.79	57.00	1.67	55.19	1.61	53.38	1.55	49.76	1.44
	3	2.2	64.24	1.75	60.62	1.64	57.00	1.53	55.19	1.48	53.38	1.43	49.76	1.32
	5	4.1	64.24	1.65	60.62	1.55	57.00	1.45	55.19	1.40	53.38	1.35	49.76	1.26
	7	6	64.24	1.57	60.62	1.47	57.00	1.38	55.19	1.33	53.38	1.29	49.76	1.19
9	7.9	64.24	1.48	60.62	1.39	57.00	1.31	55.19	1.26	53.38	1.22	49.76	1.14	
11	9.8	64.24	1.41	60.62	1.32	57.00	1.24	55.19	1.20	53.38	1.16	49.76	1.08	
13	11.8	64.24	1.33	60.62	1.25	57.00	1.18	55.19	1.14	53.38	1.10	49.76	1.03	
15	13.7	64.24	1.27	60.62	1.19	57.00	1.12	55.19	1.09	53.38	1.05	49.76	0.98	
50%	-19.8	-20	53.51	2.62	50.51	2.44	47.50	2.26	45.70	2.18	44.19	2.09	41.19	1.93
	-18.8	-19	53.51	2.56	50.51	2.39	47.50	2.22	45.70	2.13	44.19	2.05	41.19	1.89
	-16.7	-17	53.51	2.44	50.51	2.28	47.50	2.12	45.70	2.04	44.19	1.96	41.19	1.81
	-13.7	-15	53.51	2.33	50.51	2.17	47.50	2.02	45.70	1.95	44.19	1.87	41.19	1.73
	-11.8	-13	53.51	2.21	50.51	2.06	47.50	1.92	45.70	1.85	44.19	1.78	41.19	1.65
	-9.8	-11	53.51	2.09	50.51	1.95	47.50	1.82	45.70	1.76	44.19	1.69	41.19	1.57
	-9.5	-10	53.51	2.03	50.51	1.90	47.50	1.77	45.70	1.71	44.19	1.65	41.19	1.52
	-8.5	-9.1	53.51	1.98	50.51	1.86	47.50	1.73	45.70	1.67	44.19	1.61	41.19	1.49
	-7	-7.6	53.51	1.90	50.51	1.78	47.50	1.66	45.70	1.60	44.19	1.55	41.19	1.43
	-5	-5.6	53.51	1.79	50.51	1.68	47.50	1.57	45.70	1.52	44.19	1.46	41.19	1.36
	-3	-3.7	53.51	1.70	50.51	1.59	47.50	1.49	45.70	1.44	44.19	1.39	41.19	1.29
	0	-0.7	53.51	1.56	50.51	1.46	47.50	1.37	45.70	1.32	44.19	1.28	41.19	1.19
	3	2.2	53.51	1.44	50.51	1.35	47.50	1.26	45.70	1.22	44.19	1.18	41.19	1.10
	5	4.1	53.51	1.36	50.51	1.28	47.50	1.20	45.70	1.16	44.19	1.12	41.19	1.05
	7	6	53.51	1.29	50.51	1.22	47.50	1.14	45.70	1.11	44.19	1.07	41.19	1.00
9	7.9	53.51	1.23	50.51	1.16	47.50	1.09	45.70	1.06	44.19	1.02	41.19	0.95	
11	9.8	53.51	1.17	50.51	1.10	47.50	1.04	45.70	1.00	44.19	0.97	41.19	0.91	
13	11.8	53.51	1.11	50.51	1.05	47.50	0.99	45.70	0.96	44.19	0.93	41.19	0.87	
15	13.7	53.51	1.06	50.51	1.00	47.50	0.94	45.70	0.91	44.19	0.88	41.19	0.83	

Note:

- 1, is shown as reference
- 2, In heating mode, avoid the outdoor air temperature range from -15 to -20 degree C, when selecting the models
- 3, The above table shows the average value of conditions may operate
- 4, It is recommended to connect less than 130%

8. Sound Levels

Standard of testing

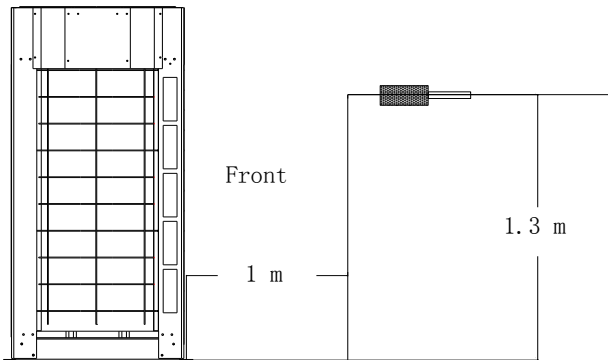

Test value

Outdoor unit (HP)	Noise level (dB)
8	57
10	57
12	58
14	60
16	60
18	63
20	63
30	64

Sound Curve:

18,20 HP

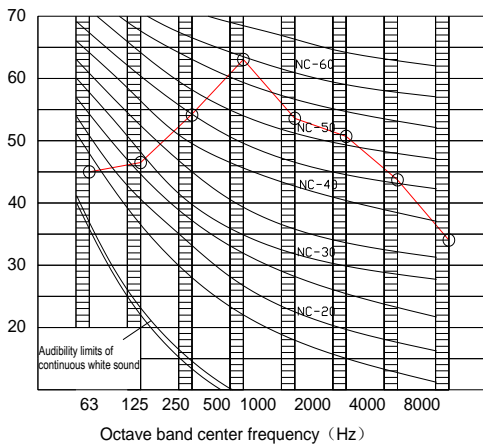

30HP

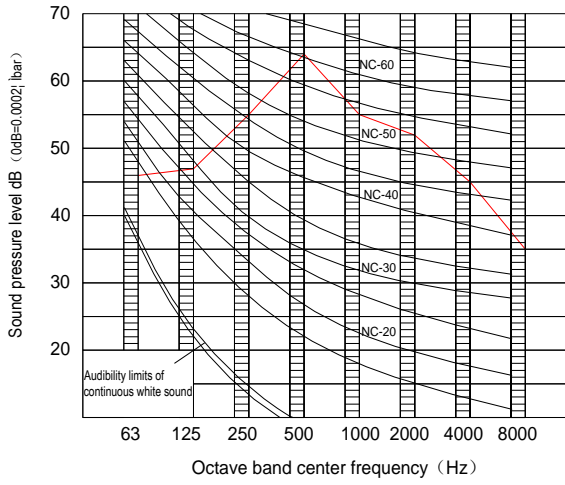

9. Outdoor Fan performance

9.1 18/20HP Curve diagram of static pressure, air flow volume:

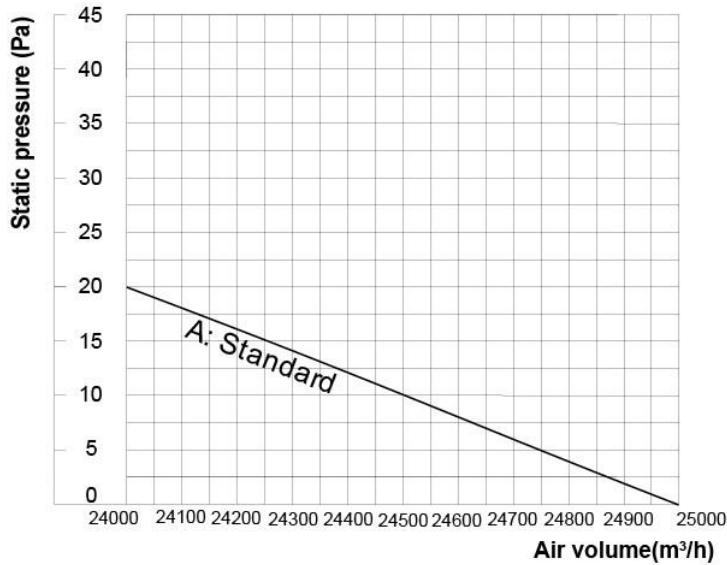

9.2 30HP Curve diagram of static pressure, air flow volume:

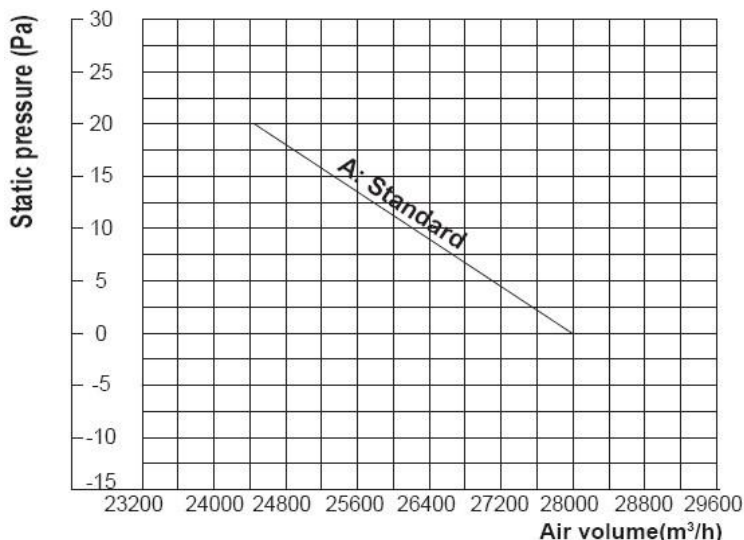

10 Accessories

10.1 Standard accessories

No	Name	Quantity	Purpose
1	Outdoor unit installation manual	1	/
2	Outdoor unit owner's manual	1	(Be sure to deliver it to the customer)
3	Indoor unit owner's manual	2	(Be sure to deliver it to the customer)
4	Screw bag	1	Spare
5	Toggling flathead screw	1	For toggling of indoor and outdoor unit
6	Gauge joint subassembly	1	For airtight test
7	Seal plug	4x2	For cleansing pipes
8	90° elbow	1	Pipe connecting
9	Connection pipe subassembly	1	For connecting liquid side
10	Indoor unit branch pipe installation manual	1	/

10.2 Optional accessories

Optional accessories	Model name	Function
Branch Joint of indoor side	FQZHN-01C	Distribute the refrigerant to Indoor Units and balance the resistance between each outdoor unit.
	FQZHN-02C	
	FQZHN-03C	
	FQZHN-04C	
	FQZHN-05C	
Outdoor controller	MD-CCM02/E	Monitor the outdoor operating parameter
Three phase electricity power protector	HYJ-IV202301600300	To stop the air-conditioner running in case of bad power supply such as Phase Error, Over-voltage, Under-voltage lose, phase lost and phase sequence inverse. Thus to protect the
Digital ammeter (WHM)	DTS634/DT636	Electricity Charge monitor

11 Functional parts and safety devices

Item	Symbol	Name	MDVi-530(18)W/DRN1-i(B)	MDVi-560(20)W/DRN1-i(B)	
Compressor	Inverter	Inverter compressor	E405DHD-36D2YG	E405DHD-36D2YG	
	FIX1	Fixed speed compressor	E605DH-59D2YG	E605DH-59D2YG	
	FIX2	Fixed speed compressor	E605DH-59D2YG	E605DH-59D2YG	
	FIX3	Fixed speed compressor	E605DH-59D2YG	E605DH-59D2YG	
	Compressor	Open temperature	120℃		
	Safety OLP	Starting current	--/62A/62A	--/62A/62A	
	CCH	Crank case heater	DJRD-515A-2000-33W *3		
Motor and Security Devices	Motor	Fan motor	Model		
			Output power	450W*2	450W*2
		Safety thermostat	On	145℃	
			Off	95℃	
	HP	High pressure switch	OFF: 4.4 (±0.1) MPA/ON: 3.2 (±0.1) MPA		
	LP	Low pressure switch	OFF: 0.05 (±0.05) MPA/ON: 0.15 (±0.05) MPA		
Temperature sensor	T3,T4	Temperature sensor (condenser outlet/ambient)	25℃=10KΩ		
	Discharge	Thermostat (Inverter/Fixed discharge)	BW130℃ ON:130℃ OFF:85℃		
Pressure	HPSH	High pressure sensor (discharge)	Model:YLCGQ-NSK-BD046I-U298		
Functional Parts	PMV	Electronic expansion valve	D32MISZ-1R (2 sets) Buer		
	4-W/V	4-way valve	STF-07N1 Foshan Hualu		
	SV	Solenoid valve	DXF-06V, etc. Changheng		

Item	Symbol	Name	MDVi-850(30)W/DRN1-i(B)		
Compressor	Inverter	Inverter compressor	E405DHD-36D2YG		
	FIX1	Fixed speed compressor	E655DH-65D2YG(GC)		
	FIX2	Fixed speed compressor	E655DH-65D2YG(GC)		
	FIX3	Fixed speed compressor	E655DH-65D2YG(GC)		
	FIX4	Fixed speed compressor	E655DH-65D2YG(GC)		
	FIX5	Fixed speed compressor	E655DH-65D2YG(GC)		
	Compressor	Open temperature	120℃		
	Safety OLP	Starting current	--/62A/62A		
	CCH	Crank case heater	DJRD-520A-2500-27.6W*4; DJRD-520A-1500-27.6W*3		
Motor and Security Devices	Motor	Fan motor	Model		
			Output power	750W*2	
		Safety thermostat	On	115℃	
			Off	/	
	HP	High pressure switch	OFF: 44 (±0.1) kg/cm ² /ON: 3.2 (±0.1) kg/cm ²		
	LP	Low pressure switch	OFF: 0.05 (±0.05) kg/cm ² /ON: 0.15 (±0.05) kg/cm ²		
Temperature sensor	T3,T4	Temperature sensor (condenser outlet/ambient)	25℃=10KΩ		
	Discharge	Thermostat (Inverter/Fixed discharge)	BW130℃ ON:130℃ OFF:85℃		
Pressure sensor	HPSH	High pressure sensor (discharge)	Model: YLCGQ-NSK-BD046I-U298Character: Vout=0.86*P+0.5 (MPa)		
Functional Parts	PMV	Electronic expansion valve	D32MISZ-1R Shanghai Yinzhou		
	4-W/V	4-way valve	STF-07N1 Foshan Hualu		
	SV	Solenoid valve	DXF-18A, etc. Hunan changzhou		

Legend: OLP : Over load protection

Part 4 Installation

1 Installation Introduction.....	107
2 Units Installation	117
2.1 Installation of Indoor Unit	117
2.2 Installation of Outdoor Unit	118
3 Refrigerant Pipe Engineering.....	126
3.1 Refrigerant Pipe Processing	126
3.2 Air Tight Test.....	136
3.3 Vacuum Drying	138
3.4 Recharge of Refrigerant	139
4 Drainage Pipe Engineering.....	141
5 Duct Engineering.	146
6 Heat Insulation Engineering.....	149
7 Electrical Engineering.....	152
8 Commissioning.	154

1. Installation Introduction

1.1 Select the Refrigerant Piping for V4+ modular type

1.1.1 Length and drop height permitted of the refrigerant piping

		Permitted length		Pipe
Pipe length	Total pipe length (actual length)	≤30HP	≤350 m	$L_1+L_2+L_3+...+$
		> 30HP	≤500 m	L_8+L_9 $+a +b +c+...+i +j$
	Farthest pipe length (m)	Actual length	≤150m	
Equivalent length		≤175m		
Equivalent length L of pipe from the first branch to the farthest one		≤40m		$L_6+L_7+L_8+L_9+j$
Drop height	Drop height between indoor unit and outdoor unit	Outdoor unit up	≤70m	=
		Outdoor unit down	≤50m	
	Drop height between indoor unit and indoor unit	≤15m		

Note: Each branch equals to 0.5m pipe length.

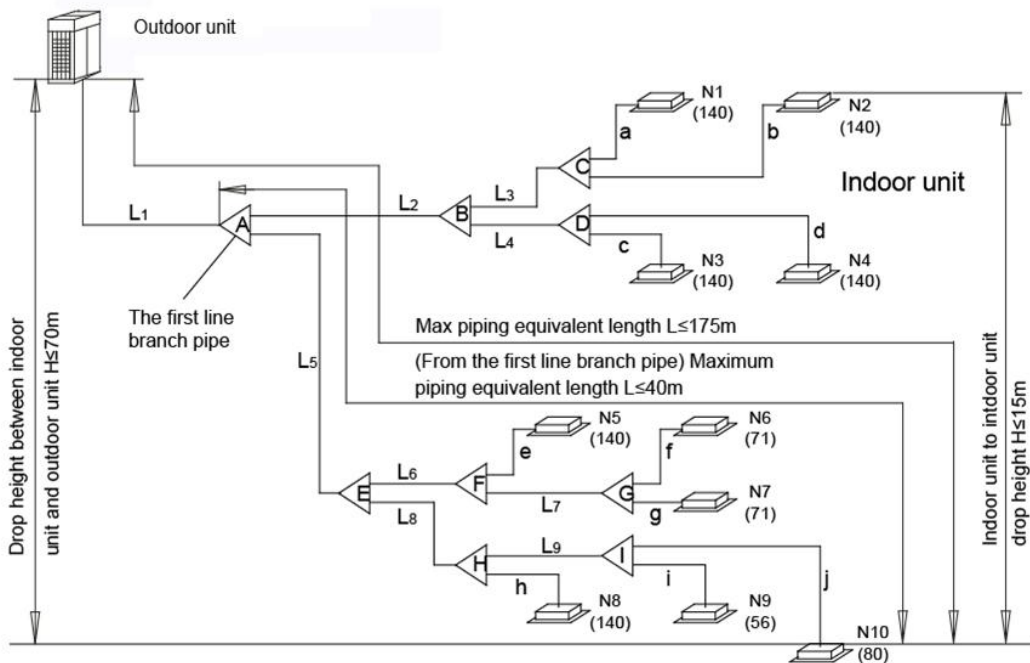

Note:

1. All branches must be purchased from Midea, otherwise system is induced to malfunction.

1.1.2 Select the refrigerant piping

Main Line	L1
Main Trunk	L2, L3, L4, L5, L6
Indoor unit branch pipe	a, b, c, d, e, f, g
Pipes between branch pipe and indoor unit	A, B, C, D, E, F

Note: The equivalent length for all liquid pipes is $L1+L2+L3...+L7+L8...+L9+0.5 \times 6$ (The equivalent length for each branch pipe is 0.5m)

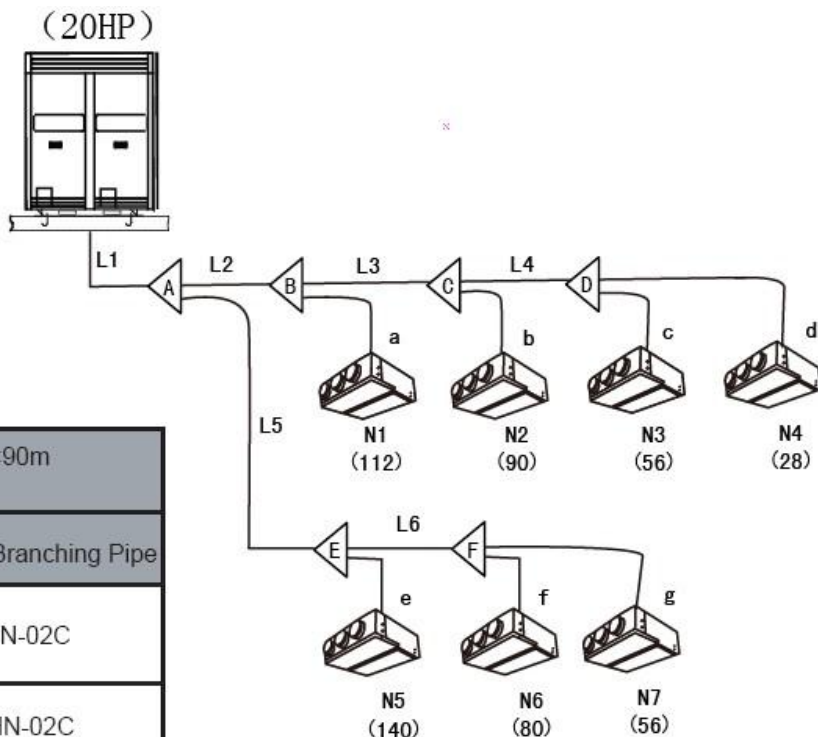

Size of joint pipes for R410A Outdoor unit

Model	The equivalent length for all pipes < 90m Size of main pipe (mm)		
	Gas side	Liquid side	The 1st Branching Pipe
8HP	Φ22.2	Φ12.7	FQZHN-02C
10HP	Φ25.4	Φ12.7	FQZHN-02C
12/14HP	Φ28.6	Φ12.7	FQZHN-03C
16HP	Φ28.6	Φ12.7	FQZHN-03C
18-20HP	Φ31.8	Φ15.9	FQZHN-03C
30HP	Φ34.9	Φ19.1	FQZHN-04C

Size of joint pipes for R410A indoor unit

Capacity of indoor unit (A)	Size of main pipe(mm)		Branch pipe
	Gas side	Liquid side	
A<166	Φ19.1	Φ9.5	FQZHN-01C
166≤A<230	Φ22.2	Φ9.5	FQZHN-02C
230≤A<330	Φ22.2	Φ12.7	FQZHN-02C
330≤A<460	Φ28.6	Φ12.7	FQZHN-03C
460≤A<660	Φ28.6	Φ15.9	FQZHN-03C
660≤A<920	Φ34.9	Φ19.1	FQZHN-04C

Size of joint pipes for R410A outdoor unit

Model	The equivalent length for all pipes≥90m Size of main pipe(mm)		
	Gas side	Liquid side	The 1st Branching Pipe
8HP	Φ25.4	Φ12.7	FQZHN-02C
10HP	Φ25.4	Φ12.7	FQZHN-02C
12/14HP	Φ31.8	Φ15.9	FQZHN-03C
16HP	Φ31.8	Φ19.1	FQZHN-03C
18-20HP	Φ31.8	Φ19.1	FQZHN-03C
30HP	Φ38.1	Φ22.2	FQZHN-04C

The dimension of indoor unit brunch pipe and the connective method

Indoor unit capacity A(×100W)	When branching pipe's length ≤10m		When branching pipe's length > 10m	
	Gas side	Liquid side	Gas side	Liquid side
A≤45	Φ12.7	Φ6.4	Φ15.9	Φ9.5
A≥56	Φ15.9	Φ9.5	Φ19.1	Φ12.7

Note: For ensuring the optimal efficiency of indoor unit, please limit the pipe length within 5m, otherwise, if the length exceed than 10m, would affect the unit efficiency. The length over than 20m is unallowable.

1.1.3 Pipe selection example

E.g. Take Fig. 5-4 the 20HP pipe as example verifies the selection of the pipe. (Provided that all equivalent length of the pipes are 90m, each branch pipe's length is 5m.)

- 1) Branch pipe a~g, which length are 8m. See Table 5-5 for the branch pipes a, b, c, e, f, g which diameters are Φ15.9/Φ9.5; the branch pipe d which diameter isΦ12.7/Φ6.4.
- 2) The main pipe L6 downstream with the indoor unit N6 and N7, the capacity of that is 80+56=136<168. Refer to table 5-4 for the main pipe L6 diameter is 15.9/Φ9.5. We select the FQZHN-01 for the branch pipe assembly F.
- 3) The main pipe L5 downstream with the indoor unit N5 ~ N7, the capacity of that is 140+80+56=276<330. Refer to table 5-4 for the main pipe L5 diameter is Φ22.2/Φ9.5. We select the FQZHN-02 for the branch pipe assembly E.
- 4) The main pipe L4 downstream with the indoor unit N3 and N4, the capacity of that is 140+80+56=276<330. Refer to table 5-4 for the main pipe L4 diameter is Φ15.9/Φ9.5. We select the FQZHN-01 for the branch pipe assembly D.
- 5) The main pipe L3 downstream with the indoor unit N2 ~ N4, the capacity of that is 90+56+28=174<224. Refer to table 5-4 for the main pipe L4 diameter is19.1/Φ9.5. We select the FQZHN-01 for the branch pipe assembly C.
- 6) The main pipe L2 downstream with the indoor unit N1 ~ N4, the capacity of that is 112+90+56+28=286<330. Refer to table 5-4 for the main pipe L2 diameter is Φ22.2/Φ9.5. We select the FQZHN-02 for the branch pipe assembly B.
- 7) The branch pipe assembly A downstream with the indoor unit N1 ~ N7, the capacity of that is 140+80+56+112+90+56+28=562<710. Refer to table 5-4, select the FQZHN-03 for the branch pipe assembly A.
- 8) Confirm the main pipe: For the reason of all equivalent length of the pipes in Fig. 5-2 are ≥90m, and the outdoor unit capacity is 20HP, thus we could find out the main pipe' s dimension is 31.8/Φ19.1 according to table.5-3

Note: For the detail dimension and installation information pipe, please read the branch pipe installation manual carefully.

Note:The branch joints must be the level laying ,otherwise can cause the cold intermediary assignment to be uneven! And multi-Taiwan parallel outdoor unit must be in the identical altitude.

1.3 Installation Procedure

1.3.1 Importance of the Installation Operation

Effect of installation issues on equipment:

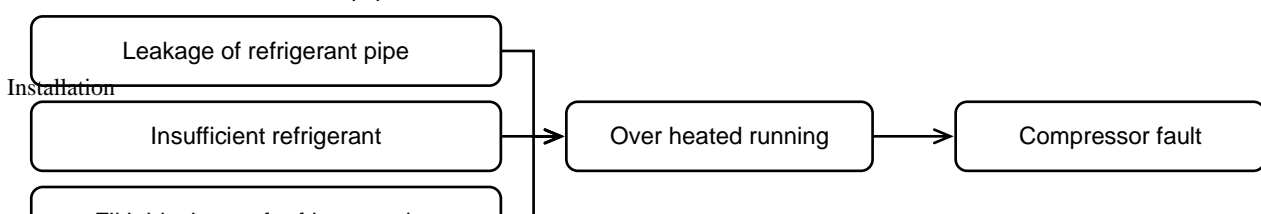

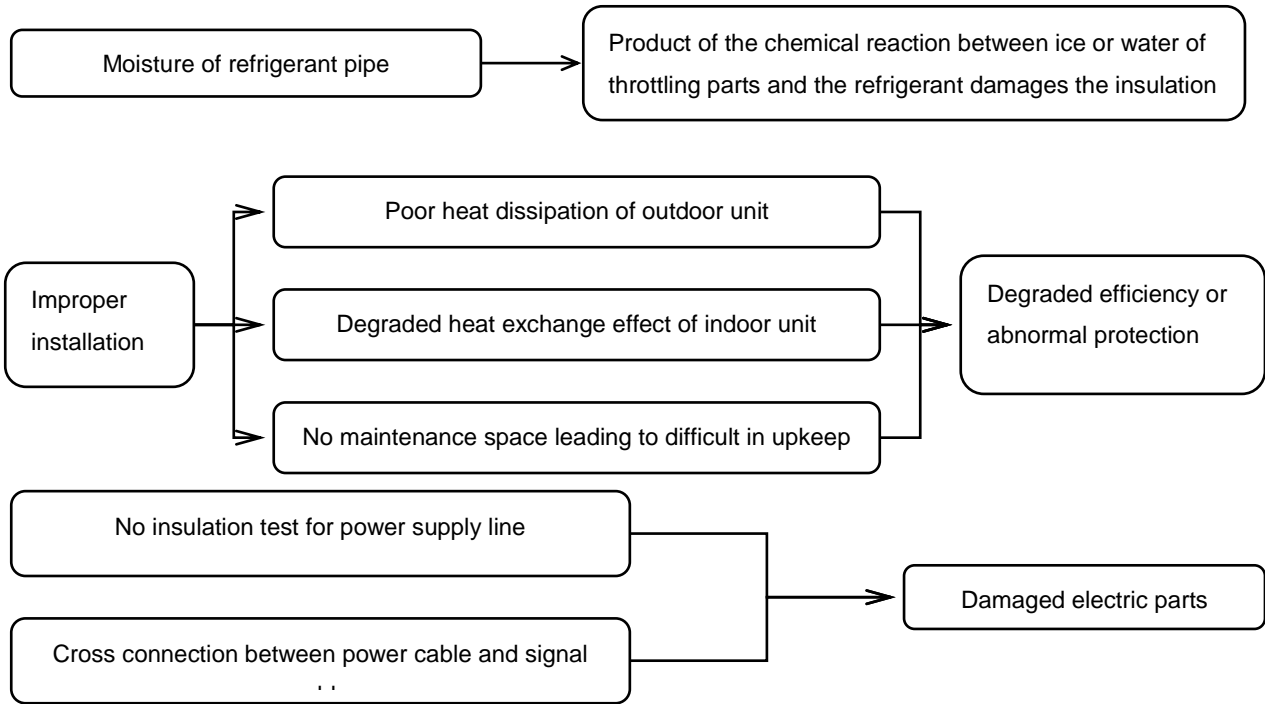

1.3.2 General procedure

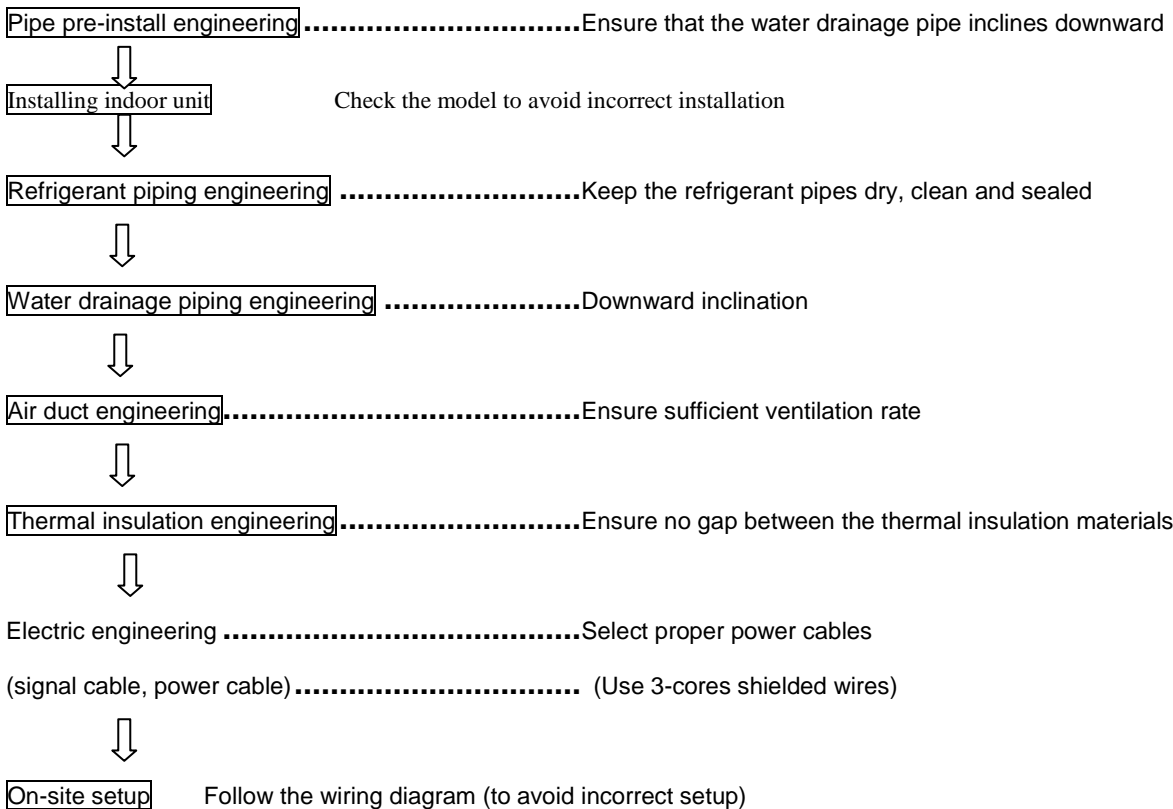

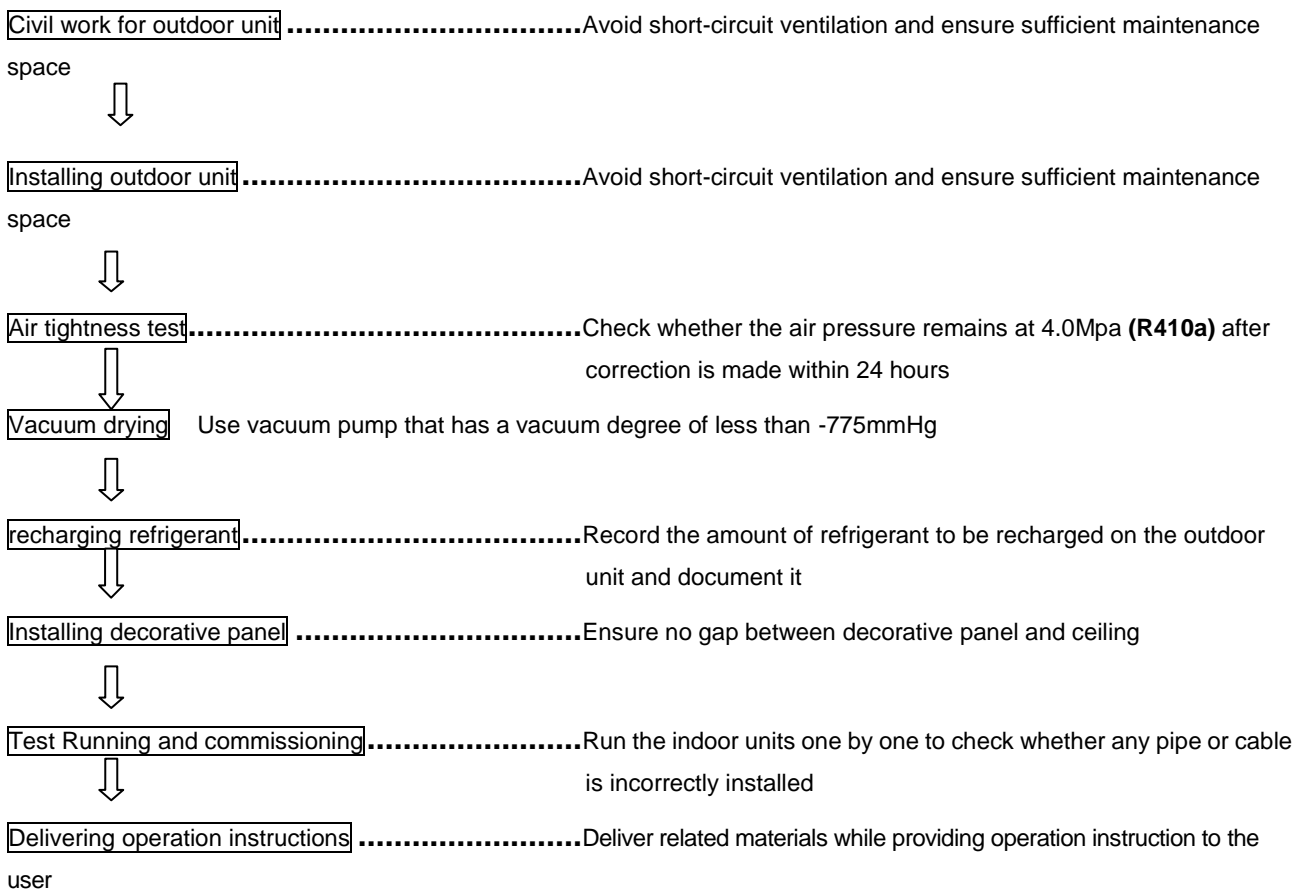

Note:The general procedure for refrigerant machine is subject to change according to the situation

1.3.2 Install indoor unit's procedure

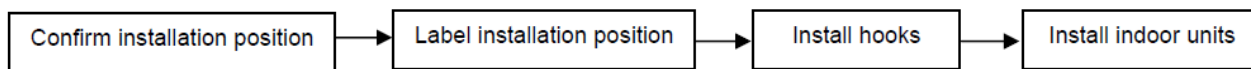

- Note:**
- 1.The hook must strong enough to sustain the weight of indoor unit.
 - 2.Check the models of indoor units before installation.
 - 3.Pay attention to the main devices, such as the pipeline.
 - 4.Hold enough places for maintenance.

1.3.3 Refrigerant pipe procedure

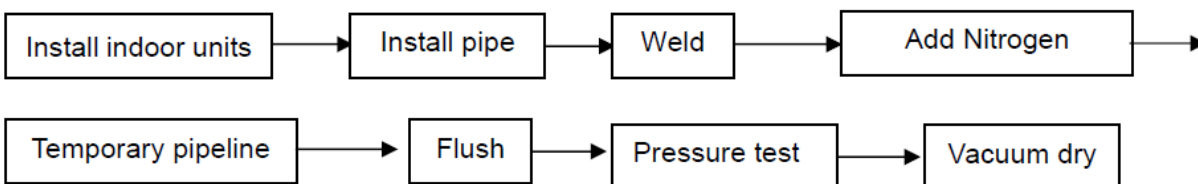

1.3.4 Drainage pipe procedure

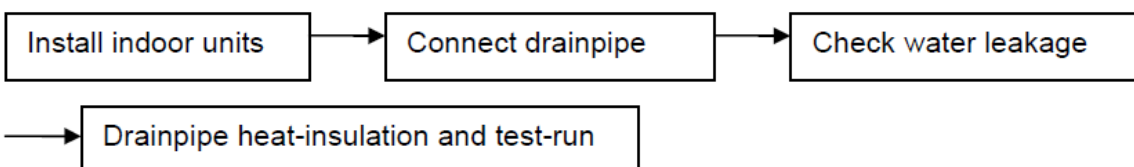

Note: It is no need to insulate the drainpipe if you choose the plastic pipe as drainpipe.

1.3.5 Electric wiring

1.3.5.1 Please select power supply for indoor unit and outdoor unit separately. Both indoor units and outdoor units should be grounded well.

1.3.5.2 The power supply should have specified branch circuit with leakage protector and manual switch.

1.3.5.3 Please put the connective wiring system between indoor unit and outdoor unit with refrigerant piping system together.

1.3.5.4 Power wiring should be done by professional electrician and complied with relevant National Electric Standard.

1.3.5.5 The power supply, leakage protector and manual switch of all the indoor units connecting to the same outdoor unit should be universal. (Please set all the indoor unit power supply of one system into the same circuit.)

1.3.5.6 It is suggested to use 3-core shielded wire as signal wire between indoor and outdoor units, multi-core wire is unavailable. Pay attention to the consistency. When signal wire parallel to the power wire, please keep enough distance (about 300mm at least) to prevent interference.

1.3.5.7 The power wire and signal wire can't be enlaced together.

1.3.6 Lay the indoor pipeline

Note: Collocate the air-outlet reasonably to prevent airflow short-circuit. Check the static pressure whether in the allowable range. The air filters should be easy to unpick and wash. Do pressure test on pipeline.

1.3.7 Heat-insulation procedure

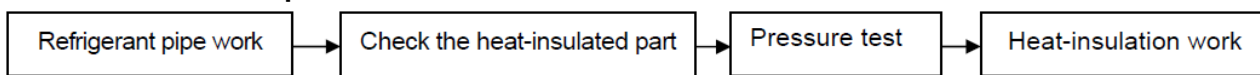

Note: For welding part, flare part and branch pipe, heat-insulation work must be done after finished the pressure test.

1.3.8 Install outdoor unit

Note: 1. Gutter must be set around the foundation to drain the condensation water.

2. When installing outdoor units at the roof, please check the strength of the roof and pay attention not to destroy the waterproof of the roof.

1.3.9 Recharge refrigerant procedure

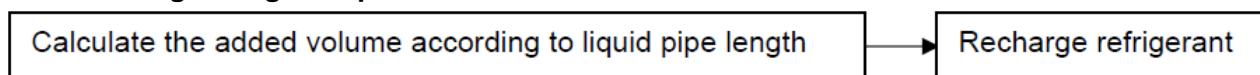

Note: Please calculate the additional amount of refrigerant according to the formula that we supply to you, and the calculation result must be correct

1.3.10 Main points of test running and Commissioning

Please check the following issues before turning on the power:

1.3.10.1 Vacuum dry: Make sure the vacuum degree accord with our requirement about 10^{-5} .

1.3.10.2 Wiring: Includes the power wiring and communication wiring; Recheck the connection according to our corresponding wire diagrams. Especially, please remember our communication wire is polar; it means you must connect the communication wire correspondingly to the terminal block.

1.3.10.3 Additional charge of refrigerant: Recheck the calculation formula and recalculate the total recharge volume according to our supplied formula.

1.3.10.4 Open the stop-valve of gas and liquid pipe with Allen key; Check leakage of stop-valve with soap water. Please confirm whether the outdoor unit has been connected to the power for 12hr before start test running.

Test running: Turn on all of the indoor units with cooling mode and set the temperature in 17degree with

high fan speed first, after the system operated, test following operation parameters of the system, including indoor units and outdoor units parameters.

1.4 Installation Preparation

1.4.1 Installation tools and instruments

All the necessary tools should be available, and their models and specifications should meet the installation and technical requirements. The instruments and meters should be tested or verified, and their scales and accuracy should meet the requirements. The common tools for installing refrigerant machine are listed below.

No.	Name	Specification/Model	No.	Name	Specification/Model
1	Pipe cutter		15	Electronic scale	
2	Steel saw		16	Stop	
3	Pipe bender	Spring, mechanic	17	Thermometer	
4	Pipe expander	Depend on the pipe diameter specification	18	Meter rule	
5	Flaring tool	Depend on the pipe diameter specification	19	Screw driver	"-", "+"
6	Brazing welder	Depend on the nozzle size	20	Adjustable spanner	
7	Scraper		21	Resistance tester	
8	File/Rasp		22	Electro probe	
9	Injection tube		23	Multimeter	
10	Double-ended pressure gauge	4.0MPa	24	Pressure reducing valve	
11	Pressure gauge	1.5MPa, 4.0MPa	25	Wire pliers	
12	Vacuum gauge	-756mmHg	26	Clamping pliers	
13	Vacuum pump	At least 4 liters/second	27	Hexagon ring spanner	
14	Horizontal rule		28	Torque wrench	

In addition, tools such as electric welder, cutter, A-shape ladder, electric drill, folding machine, forming machine, nitrogen cylinder are also generally used during the installation.

1.4.2 Audit of construction drawings

Before the engineering installation, read carefully the related drawings to understand the design intention, audit the drawings, and then work out a detailed engineering organization plan.

1. Make sure that the pipe diameters and branch pipe models meet the technical specifications.
2. Ratio of slope, drainage mode and thermal insulation of condensate water.
3. Making of air duct and air opening, and air ventilation organization.
4. Configuration specifications, model and control mode of power cables.
5. Making, total length and control mode of control cable.

The engineering construction staff should follow the construction drawing strictly during the construction. If any change is required, such change should be approved by the design department and be documented.

1.4.3. Construction organization plan

Construction organization plan serves as the comprehensive technical and economic documents that guide the construction preparation and scientific construction organization. A reasonable construction organization plan and careful implementation of it are essential to ensure smooth construction, shorten construction period, ensure construction quality, and improve economic results.

The construction plan should be concise and focuses on key procedures, construction method, and time coordination, space disposal of the construction around the features of the engineering, thus to ensure smooth construction operation.

1.4.4. Training of installation team

Establish sound training mechanisms. Service engineers are required to train installation team managers, work supervisors to train workers, and managers to train workers of special type. Establish a management mechanism in which pre-working training, before-shift disclosure and after-shift implementation are available.

1.4.5. Coordination with other sectors

Ensure smooth coordination and meticulous organization between these sectors: air conditioning, civil work, electricity, water supply and drainage, fire protection, decoration, intelligence, etc. Try best to lay pipes of the air conditioning system along the bottom of the beam. If pipes meet together at the same height, follow these principles:

1. Ensure that gravity pipes take precedence over water drainage pipes, air ducts and pressure pipes.
2. Ensure that large pipes take precedence over air ducts and small pipes.

1.4.6. Pipe pre-install engineering

1.4.6.1. Operation procedure

Raise requirements to the civil work sector and coordinate → Determine the position, size and quantity of the machines, and conduct pre-installing → Check the pre-installing results

1.4.6.2. Pipeline route

1. The pipe for condensate water should have a downward slope (the slope should be at least 1/100).
2. The diameter of the through hole for the refrigerant pipe should take the thickness of the thermal insulation material into consideration (it is recommended to lay the gas pipe and liquid pipe in two separate columns).
3. Note that sometimes through hole is not allowed because of the structure of the beam.

Highlights:

- 1) When selecting the parts to be pre-installed, ensure that the weight of the accessories is also calculated.

eg. Strengthen the transfixion hole

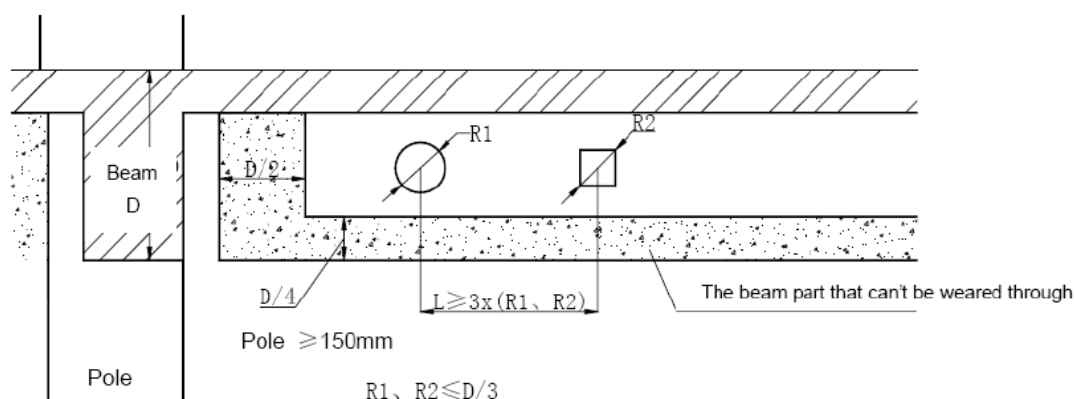

- 2) In a situation where metal parts to be pre-installed is not allowed, use expansion bolts while ensuring sufficient load-bearing capacity.

Caution: The above figure is for reference only. It is not recommended to dig holes on either the beam or the shear wall. If such operation is indeed needed, please consult the property owner (or manager) and the civil work sector, and get written approval from the competent authority.

1.4.7 Warning

- (1) Be sure only trained and qualified service personnel to install, repair or service the equipment. Improper installation, repair, and maintenance may result in electric shocks, short-circuit, leaks, fire or other damage to the equipment.
- (2) Install according to this installation instructions strictly.
If installation is defective, it will cause water leakage, electrical shock fire.
- (3) When installing the unit in a small room, take measures against to keep refrigerant concentration from exceeding allowable safety limits in the event of refrigerant leakage.
Contact the place of purchase for more information. Excessive refrigerant in a closed ambient can lead to oxygen deficiency.
- (4) Use the attached accessories parts and specified parts for installation. Otherwise, it will cause the set to fall, water leakage, electrical shock fire.
- (5) Install at a strong and firm location which is able to withstand the set's weight.
If the strength is not enough or installation is not properly done, the set will drop to cause injury.
- (6) The appliance must be installed 2.5m above floor.
- (7) The appliance shall not be installed in the laundry.
- (8) Before obtaining access to terminals, all supply circuits must be disconnected.
- (9) The appliance must be positioned so that the plug is accessible.
- (10) The enclosure of the appliance shall be marked by word, or by symbols, with the direction of the fluid flow.
- (11) For electrical work, follow the local national wiring standard, regulation and installation instruction. An independent circuit and single outlet must be used.
If electrical circuit capacity is not enough or defect in electrical work, it will cause electrical shock fire.
- (12) Use the specified cable and connect tightly and clamp the cable so that no external force will be acted on the terminal.
If connection or fixing is not perfect, it will cause heat-up or fire at the connection.
- (13) Wiring routing must be properly arranged so that control board cover is fixed properly.
If control board cover is not fixed perfectly, it will cause heat-up at connection point of terminal, fire or electrical shock.
- (14) If the supply cord is damaged, it must be replaced by the manufacture or its service agent or similarly qualified person in order to avoid a hazard.
- (15) An all-pole disconnection switch having a contact separation of at least 3mm in poles should be connected in fixed wiring.
- (16) When carrying out piping connection, take care not to let air substances go into refrigeration cycle. Otherwise, it will cause lower capacity, abnormal high pressure in the refrigeration cycle, explosion and injury.
- (17) Do not modify the length of the power supply cord or use of extension cord, and do not share the single outlet with other electrical appliances.
Otherwise, it will cause fire or electrical shock.
- (18) Carry out the specified installation work after taking into account strong winds, typhoons or earthquakes.
Improper installation work may result in the equipment falling and causing accidents.
Remark: Failure to observe a warning may result in death.

1.4.8 Caution

- (1) Ground the air conditioner.
Do not connect the ground wire to gas or water pipes, lightning rod or a telephone ground wire.
Incomplete grounding may result in electric shocks.

(2) Be sure to install an earth leakage breaker.

Failure to install an earth leakage breaker may result in electric shocks.

(3) Connect the outdoor unit wires, and then connect the indoor unit wires.

You are not allowed to connect the air conditioner with the power source until wiring and piping the air conditioner is done.

(4) While following the instructions in this installation manual, install drain piping in order to ensure proper drainage and insulate piping in order to prevent condensation.

Improper drain piping may result in water leakage and property damage.

(5) Install the indoor and outdoor units, power supply wiring and connecting wires at least 1 meter away from televisions or radios in order to prevent image interference or noise.

Depending on the radio waves, a distance of 1 meter may not be sufficient enough to eliminate the noise.

(6) The appliance is not intended for use by young children or infirm persons without supervision. Young children should be supervised to ensure that they do not play with the appliance.

(7) Don't install the air conditioner in the following locations:

There is petrolatum existing.

There is salty air surrounding (near the coast).

There is caustic gas (the sulfide, for example) existing in the air (near a hot spring).

The Volt vibrates violently (in the factories).

In buses or cabinets.

In kitchen where it is full of oil gas.

There is strong electromagnetic wave existing.

There are inflammable materials or gas.

There is acid or alkaline liquid evaporating.

Other special conditions.

(8) The insulation of the metal parts of the building and the air conditioner should comply with the regulation of National Electric Standard.

Remark: Failure to observe a caution may result in injury or damage to the equipment.

2. Units Installation

2.1. Installation of Indoor Unit

2.1.1 Installation procedure

Determine the installation position → Scribing and locating → Installing suspension road → Installing the indoor unit

2.1.2 Cautions for installation and check

1) Drawing check: Confirm the specification, model and installation direction of the set.

2) Height: Ensure that it closely fits the ceiling.

3) Suspension strength: The suspension road shall be strong enough to bear the weight twice of the indoor unit to ensure that no abnormal vibration or noise is generated when the set is running.

4) When installing the indoor unit, ensure that sufficient space is available for installing condensate water pipe.

5) Horizontal degree: It shall be kept within $\pm 1^\circ$.

Purpose: Ensure smooth drainage of condensate water. Also ensure stability of the machine body to induce the risks caused by vibration and noise.

Hidden trouble of incorrect operation: a. Water leakage; b. Abnormal vibration and noise

6) Ensure sufficient maintenance & upkeep is available (keep a large enough maintenance hole,

typically 400x400mm).

7) Avoid short-circuit ventilation.

Purpose: Ensure sufficient heat exchange of indoor unit and good air conditioning effect.

Risk of incorrect operation: Poor air conditioning effect; abnormal protection of the set.

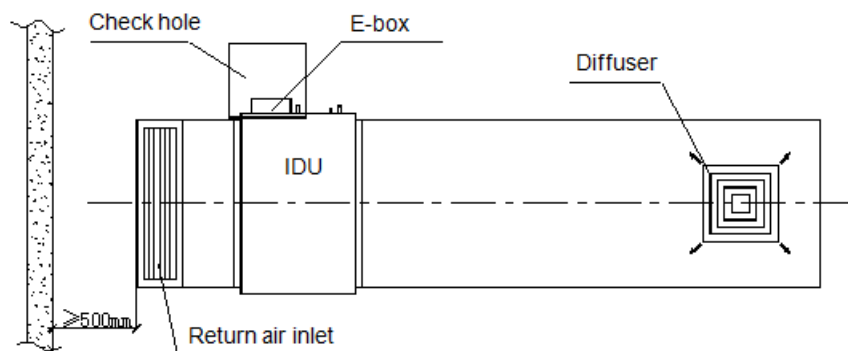

2.2. Installation of Outdoor Unit

2.2.1. Acceptance and unpacking

1. After the machine arrives, check whether it is damaged during the shipment. If the surface or inner side of the machine is damaged, submit a written report to the shipping company.
2. Check whether the model, specification and quantity of the equipment conform to the contract.
3. After removing the outer package, please keep the operation instructions well and count the accessories.

2.2.2. Hoisting outdoor unit

Do not remove any package before the hoisting. Use two ropes to hoist the machine, keep the machine in balance, and then raise it safely and steadily. In case of no package or if the package is damaged, use plates or packing material to protect it.

When conveying and hoisting the outdoor unit, keep it upright, ensure that the slope does not exceed 30°, and keep safety in mind.

2.2.3. Selecting installation position

1. Ensure that the outdoor unit is installed in a dry, well-ventilated place.
2. Ensure that the noise and exhaust ventilation of the outdoor unit do not affect the neighbors of the property owner or the surrounding ventilation.
3. Ensure that the outdoor unit is installed in a well-ventilated place that is possibly closest to the indoor unit.
4. Ensure that the outdoor unit is installed in a cool place without direct sunshine exposure or direct radiation of a high-temperature heat source.
5. Do not install the outdoor unit in a dirty or severely polluted place, so as to avoid blockage of the heat exchanger in the outdoor unit.
6. Do not install the outdoor unit in a place with oil pollution, salt or high content of harmful gases such as sulfurous gas.

2.2.4. Base for outdoor unit

1. A solid, correct base can:
 - 1) Avoid the outdoor unit from sinking.
 - 2) Avoid the abnormal noise generated due to base.
2. Base types
 - 1) Steel structure base
 - 2) Concrete base (see the figure below for the general making method)

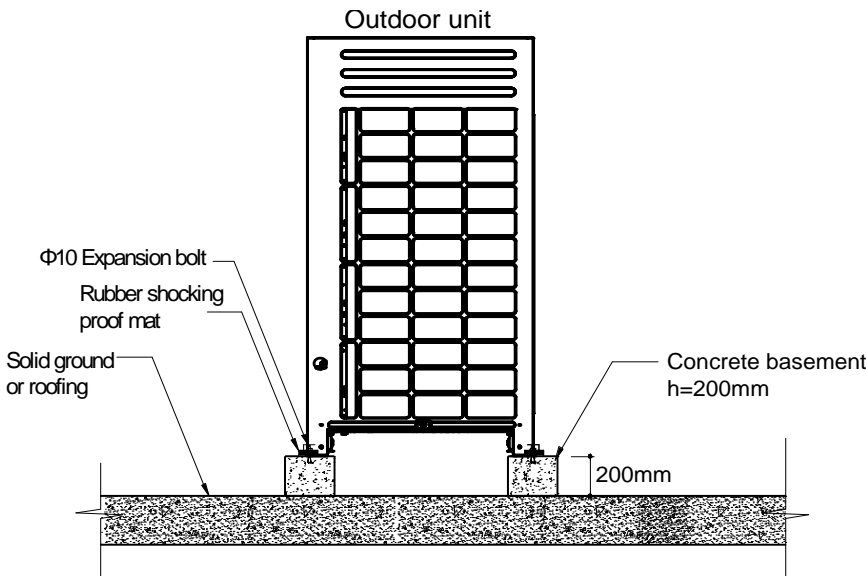

Remark:

The key points to make basement:

- 1) The master unit's basement must be made on the solid concrete ground. Refer to the structure diagram to make concrete basement in detail, or make after field measurements.
- 2) In order to ensure every point can contact equality, the basement should be on completely level.
- 3) If the basement is placed on the roofing, the detritus layer isn't needed, but the concrete surface must be flat. The standard concrete mixture ratio is cement 1/ sand 2/ carpolite 4, and adds Φ10 strengthen reinforcing steel bar, the surface of the cement and sand plasm must be flat, border of the basement must be chamfer angle.
- 4) In order to drain off the seeper around the equipment, a discharge ditch must be setup around the basement.
- 5) Please check the affordability of the roofing to ensure the load capacity.

2.2.5. Installation highlights for outdoor unit

1. Install vibration isolator or isolating pad between the set and the base by the design specification.
2. Ensure close between the outdoor unit and the base, or significant vibration and noise may occur.
3. Ensure that outdoor unit is well grounded.
4. Before commissioning, do not turn on the valves of the gas pipe and liquid pipe of the outdoor unit.
5. Ensure sufficient maintenance space is available at the installation site.

2.2.6. Installation space for outdoor unit.

1) One row:

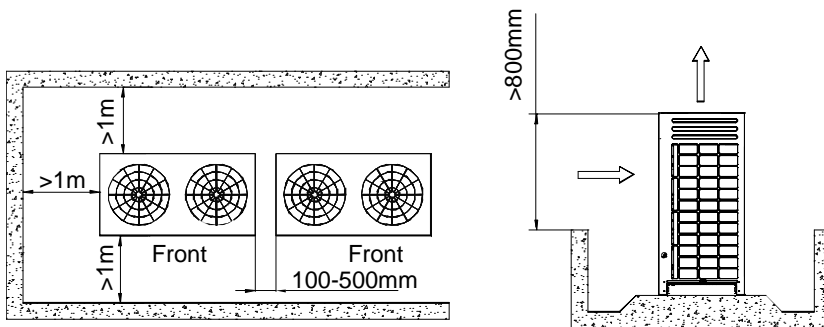

2) Two rows

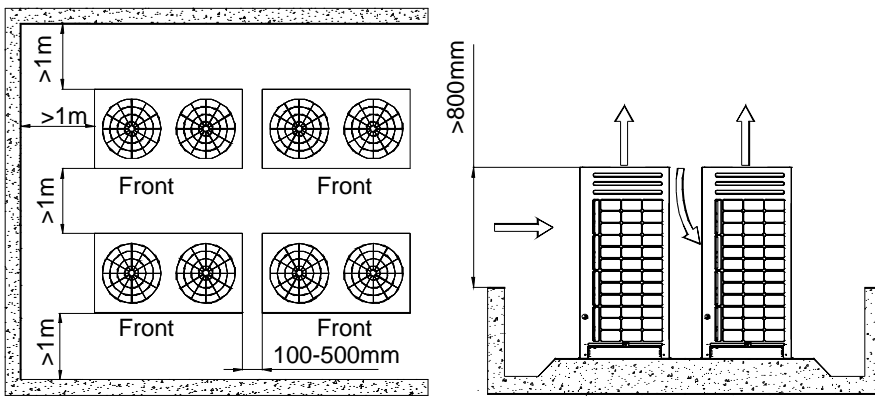

3) More than two rows

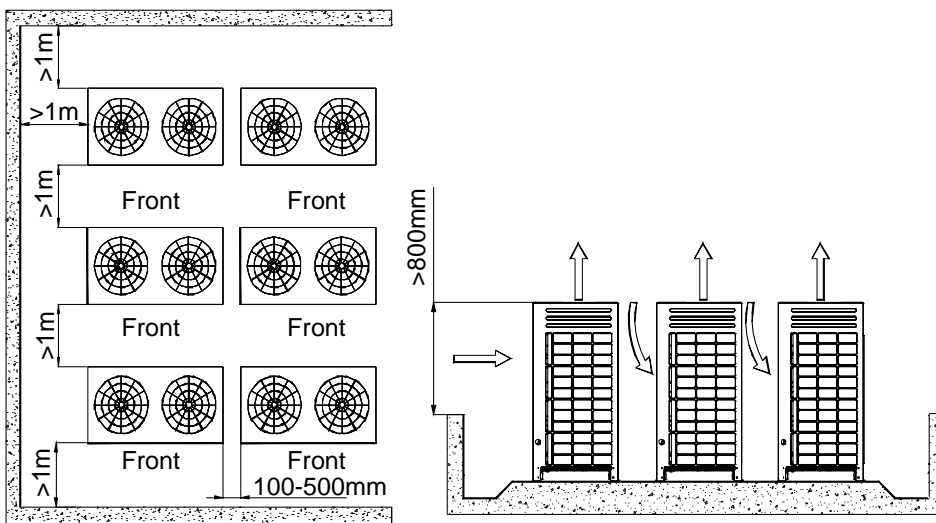

4) When the outdoor unit is lower than the surrounding obstacle,

Refer to the layout used when the outdoor unit is higher than the surrounding obstacle. However, to avoid cross connection of the outdoor hot air from affecting the heat exchange effect, please add an air director onto the exhaust hood of the outdoor unit to facilitate heat dissipation. See the figure below. The height of the air director is HD (namely H-h). Please make the air director onsite.

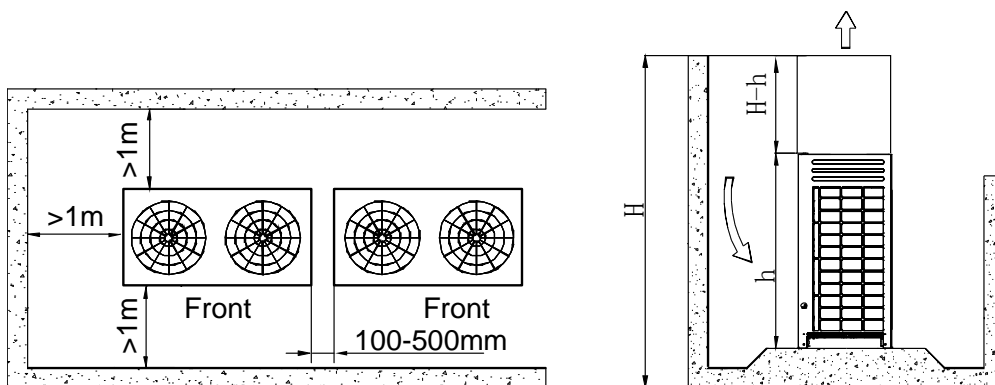

5) For limited space installation

If miscellaneous articles are piled around the outdoor unit, such articles must be 800mm below the top of the outdoor unit. Otherwise, a mechanic exhaust device must be added.

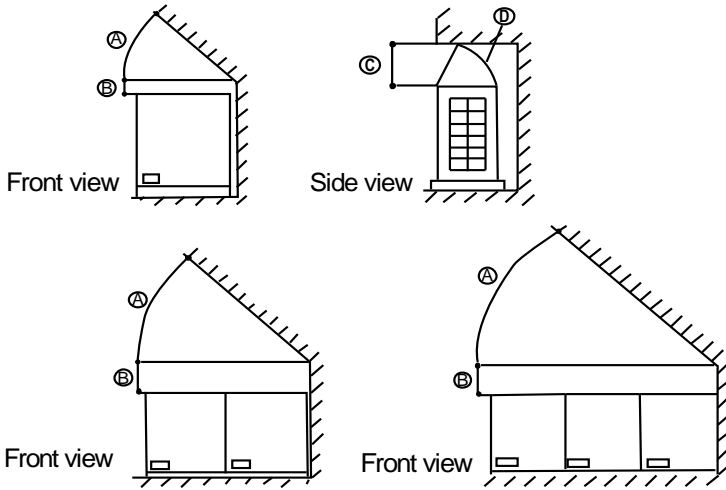

- (A) >45°
- (B) >300mm
- (C) >1000mm
- (D) Airflow deflector

6) Set the snow-proof facility

In snowy areas, facilities should be installed to prevent snow. (See the figure below) (defective facilities may cause malfunction.) Please lift the bracket higher and install snow shed at the air inlet and air outlet.

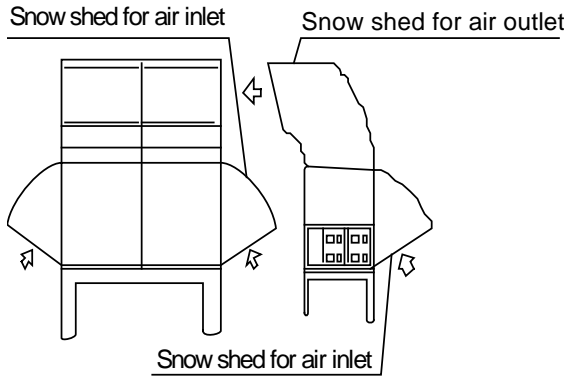

2.2.7. Mount the air deflector

2.2.7.3 Installation of MDVi-530W/DRN1-i, MDVi-560W/DRN1-i

Schedule 1:

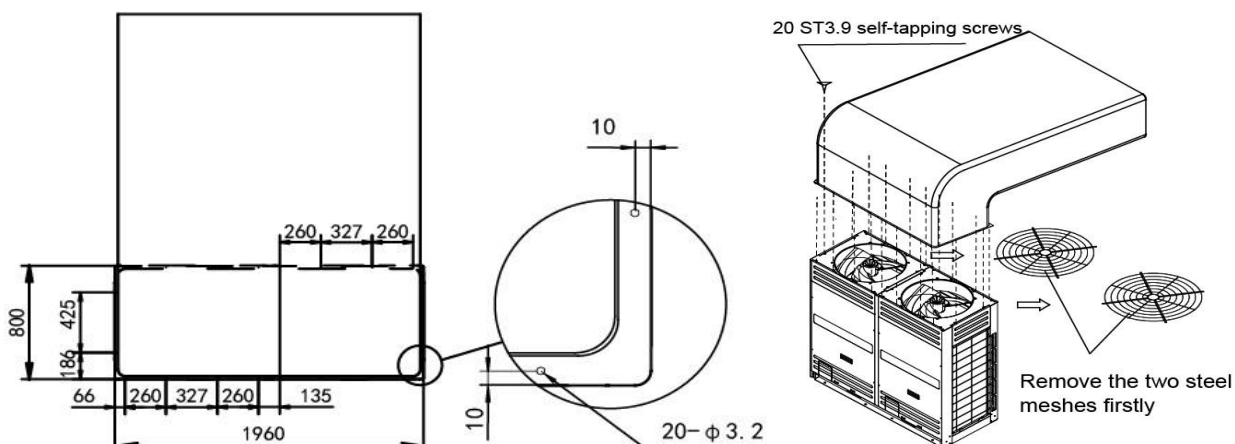
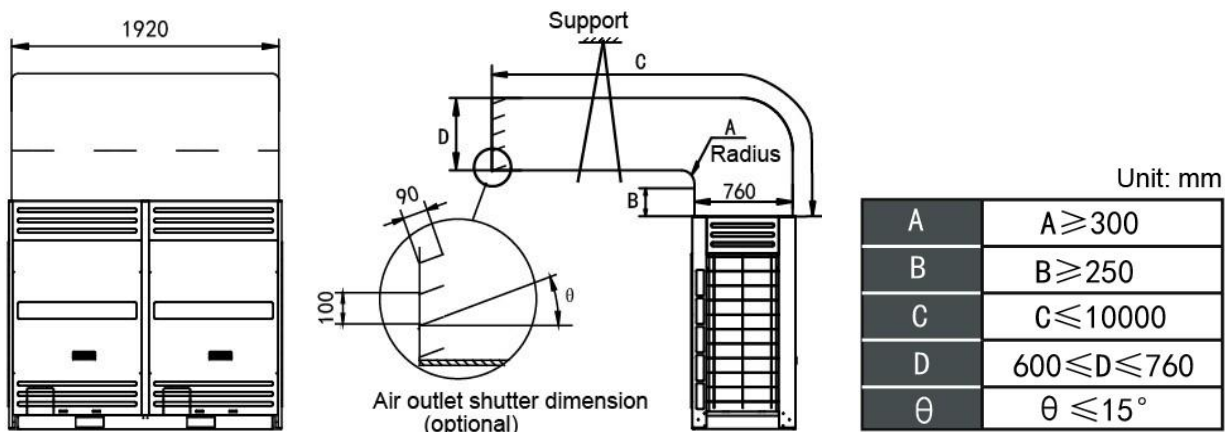

Schedule 2:

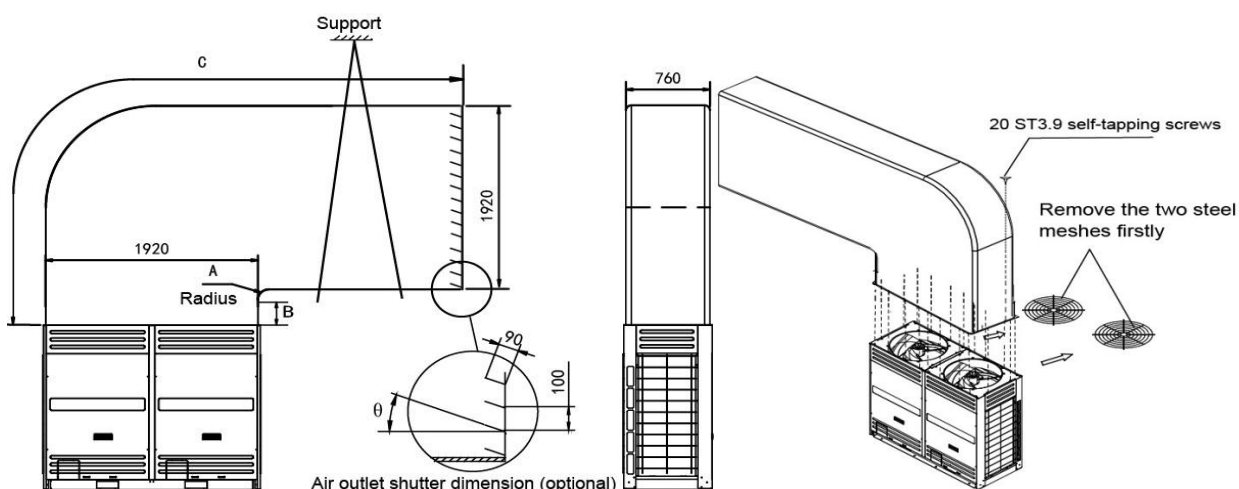

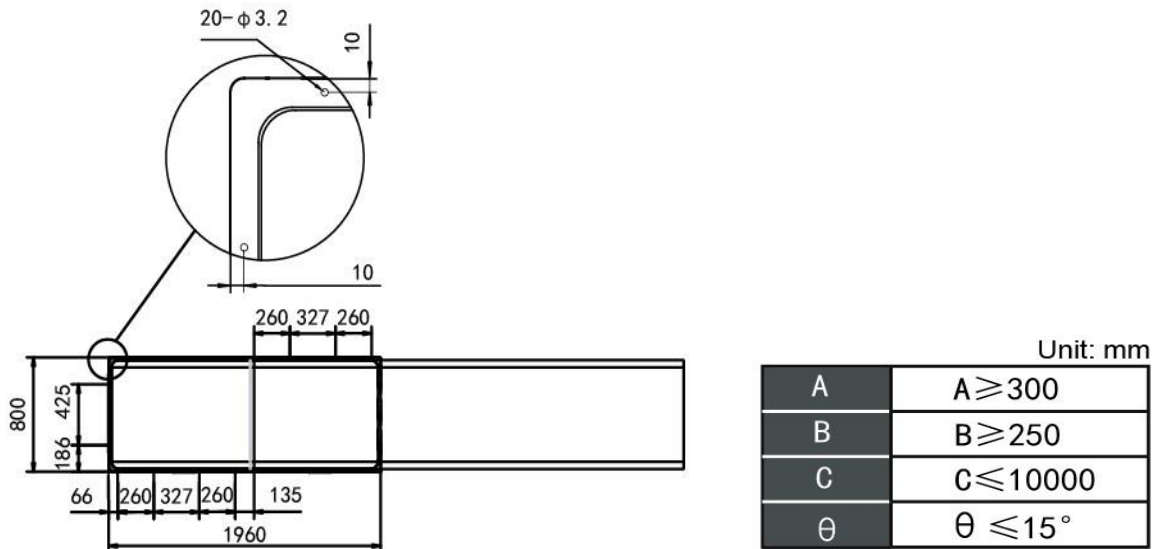

Note: Before install the air deflector, please ensuring the mesh enclosure has been took off; otherwise the air supply efficiency would be block down.

Once mounting the shutter to the unit, air volume, cooling (heating) capacity and efficiency would be block down, this affection enhance along with the angle of the shutter. Thus, we are not recommend you to mount the shutter, if necessary in use, please adjust the angle of shutter no larger than 15°. Only one bending site is allowed in the air duct, otherwise, device may be disoperation.

2.2.7.4 Installation of MDVi-850W/DRN1-i(B)

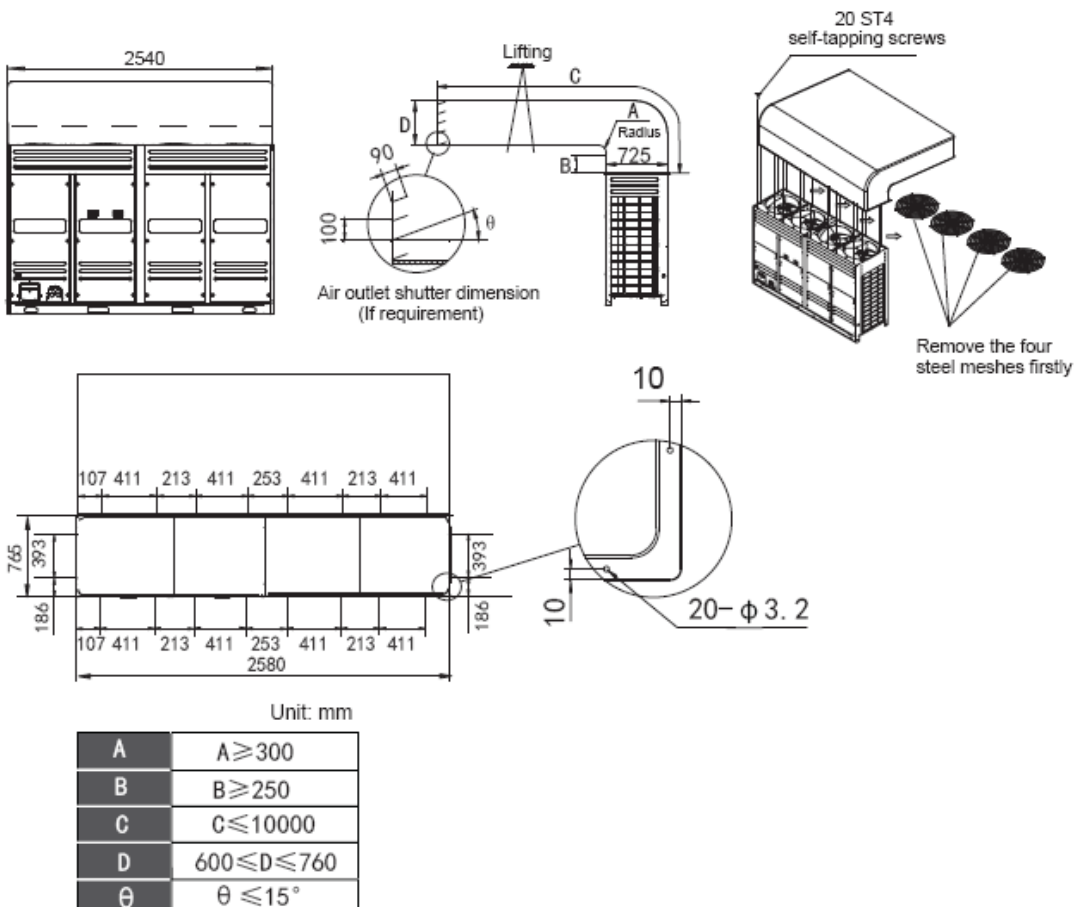

3. Refrigerant Pipe Engineering

3.1.Refrigerant Pipe Processing

3.1.1Basic requirements

3.1.1.1. Operation procedure

Determine the route and size of the pipeline according to the construction drawing → Make and installing

bracket, hanger and support → Make and arrange pipe accessories → Recharge nitrogen gas for protection

→ Brazing welding → Pipe flushing → air tightness test → Thermal insulation → Vacuum drying

3.1.1.2. Three principles for refrigerant piping

Item	Reasons	Countermeasure
Dry	The rain comes into/ Engineering water comes into/ Produced condensate water in the pipe	The process of tubing must be criterion → Blow cleanly → Vacuum
Cleanness	There are oxide produced by welding\Outside dust\ Sundries comes into	Charge nitrogen gas to prevent when welding → Blow cleanly Attention the cleanness during the piping process
Air tightness	Imprecision weld/ unqualified airproof to bell-mouth/Leakage of the fringe	Use the suited welding rod to weld Comply to the welding operation criteria Comply to bell-mouth connecting operation criteria Comply to the interface operation criteria → Air tightness test

Caution: Removing oil for copper pipe of a system that uses R410A

For the system that uses R410A, oil-free copper pipes should be selected (they can also be customized). If ordinary (oily) copper pipes are used, it must be cleaned with gauze that is dipped into tetrachloroethylene solution.

Purpose of cleansing copper pipe: Remove the lube (industrial oil used during the processing of the copper pipe) attached to the inner wall of the copper pipe. The ingredients of such lube are different from those of the lube used by the R410A refrigerant, and they will produce deposit through reaction, which may cause complicated system fault.

Special Note: Never use CCl4 for pipe cleansing and flushing, or the system will be seriously damaged.

3.1.1.3. Support for refrigerant pipe

1. Fixing horizontal pipe

When the air conditioner is running, the refrigerant pipe will deform (for example, shrunk/expanded or inclined downward). To avoid pipe damage, use hanger or support to support it (see the table below for the criteria).

Pipe Diameter (mm)	Less than Φ20	Φ20-40	Larger than Φ40
Interval between support points (m)	1	1.5	2

In general, gas pipe and liquid pipe should be suspended in parallel, and the interval between support points should be selected according to the diameter of the air pipe. Since the temperature of the flowing refrigerant will change as the operation and working condition change, which will result in hot expansion and cold shrinkage of the refrigerant pipe, so the pipe with thermal insulation should not be clamped tightly, otherwise the copper pipe may get broken due to stress concentration.

2. Fixing vertical pipe

Fix the pipe along the wall according to the pipeline route. Round log should be used at the pipe clip to

replace thermal insulation material, “U”-shape pipe should be fixed outside the round log, and the round log should be provided with anticorrosion treatment.

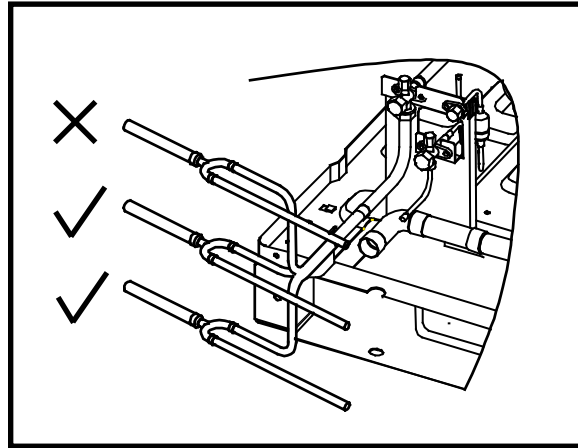

Pipe Diameter (mm)	Less than $\Phi 20$	$\Phi 20-40$	Larger than $\Phi 40$
Interval between support points (m)	1.5	2.0	2.5

3. Local fixing

To avoid stress concentration due to expansion and shrinkage of the pipe, it is usually required to conduct local fixing beside the wall through-holes of the branch pipe and end pipe.

3.1.1.4.. Requirements for installing branch pipe subassembly

When laying the branch pipe subassembly, pay attention to the following:

- 1) Do not replace branch pipe with tee pipe.
- 2) Follow the construction drawing and installation instructions to confirm the models of branch pipe subassembly as well as the diameters of main pipe and branch pipe.
- 3) Neither sharp bend (an angle of 90°) nor connection to other branch pipe subassembly is allowed at places within 500mm away from the branch pipe subassembly.
- 4) Try best to install the branch pipe subassembly at a place that facilitates welding (if doing so is impossible, it is recommended to prefabricate the subassembly).
- 5) Install vertical or horizontal branch joint, and ensure that the horizontal angle is within 10° . Refer to the right side picture:
- 6) For avoid oil accumulate at the outdoor unit, please install the branching pipes properly.

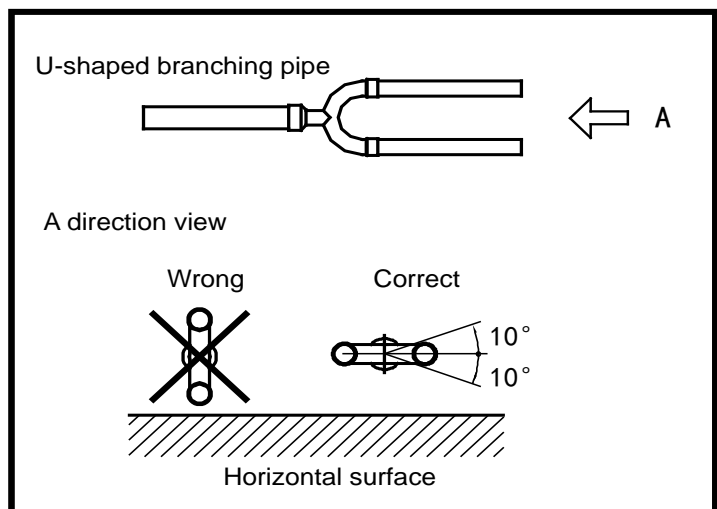
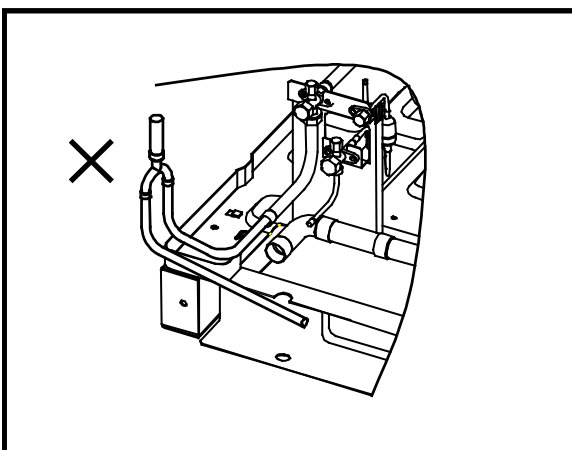

- 7) To ensure even diversion of refrigerant, pay attention to the distance between the branch pipe subassembly and the horizontal straight pipe.
 - a. Ensure that the distance between the bending point of copper pipe and the horizontal straight pipe section of the adjacent branch pipe is larger than or equal to 1m.

- b. Ensure that the distance between the horizontal straight pipe sections of the two adjacent branch pipes is larger than or equal to 1m.
- c. Ensure that the distance between the branch pipe and the horizontal straight pipe section used to connect the indoor unit is larger than or equal to 0.5m.

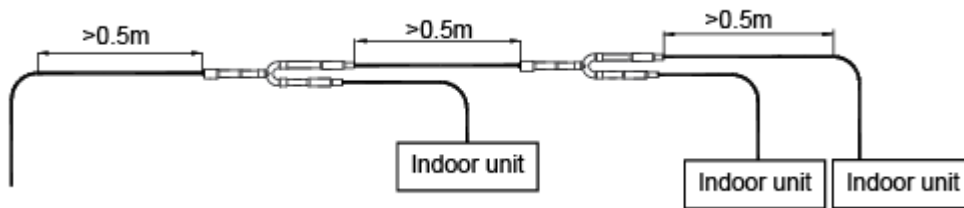

3.1.2. Storage and maintain of copper pipe

3.1.2.1. Pipe carriage and storage

1. Avoid the pipe from bending or deforming during the carriage.
2. Seal the openings of the copper pipe with end cover or adhesive tape during the storage.
3. Place the coil upright to avoid compressing deformation due to self weight.
4. Use wooden support to ensure that the copper pipe is higher than the ground, so as to make the pipe dust-proof and water-proof.
5. Take dust-proof and water-proof measures at both ends of the pipe.
6. Keep the pipes on special bracket or bench at specified place on the construction site.

3.1.2.2. Correct to seal the opening

1. There are two ways for opening sealing:

- 1) Sealing with cover or adhesive tape (suitable for short-term storage)
- 2) Sealing welding (suitable for long-term storage)

Caution: The openings of the copper pipe must be sealed at any time during the construction.

• Method of sealing with cover or adhesive tape

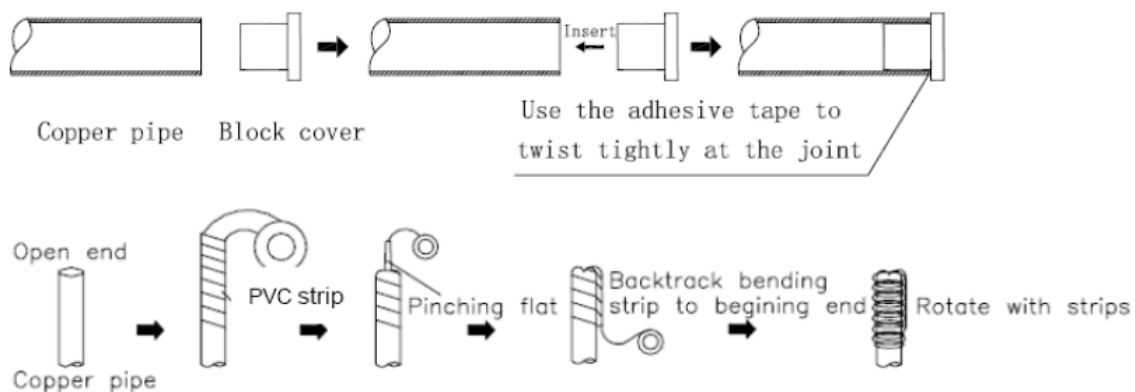

※It is recommended to seal the openings of the pipe with both cover and adhesive tape.

• Method of sealing welding



2. Special attention:

- 1) When putting the copper pipe through the hole in the wall (dirt is easy to enter into the pipe) .

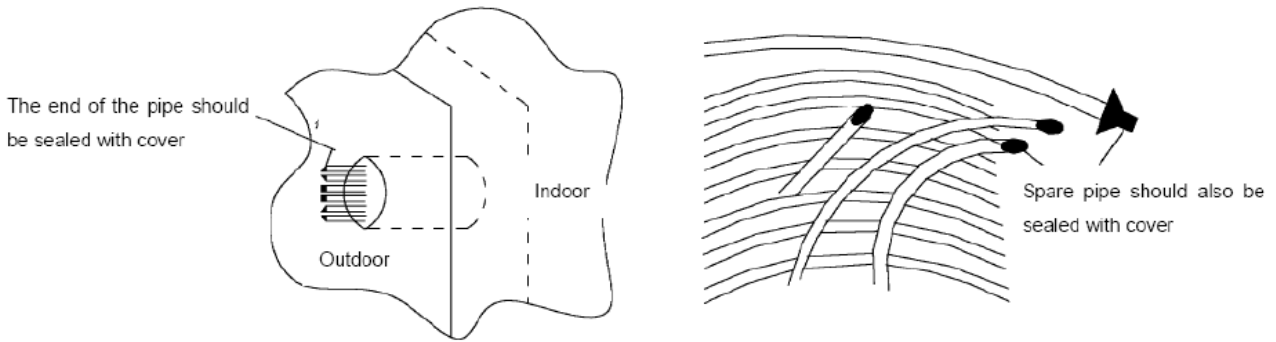

- 2) When the copper pipe goes outside the wall, ensure that no rain water can enter the pipe, particularly when the pipe is placed upright.
- 3) Before completing the pipe connection, seal the openings of the pipe with covers.
- 4) Place the openings of the pipe vertically or horizontally.

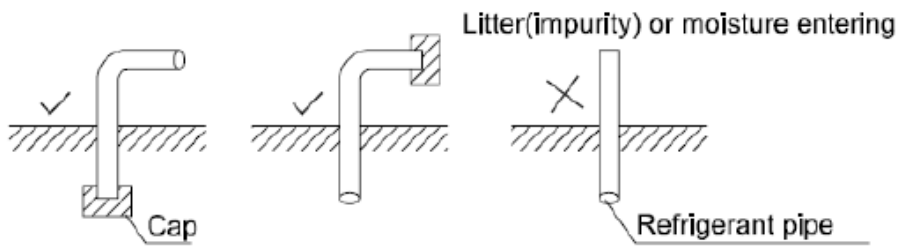

- 5) Before putting the pipe outside the wall, seal the opening of the pipe with a cover.

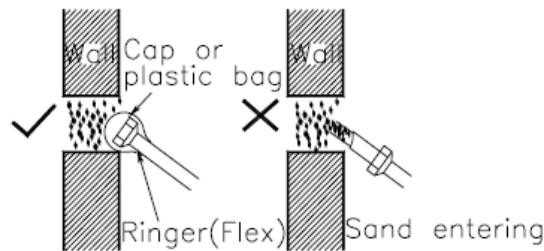

- 6) Do not place the pipe on the ground directly, or keep it away from ground friction.

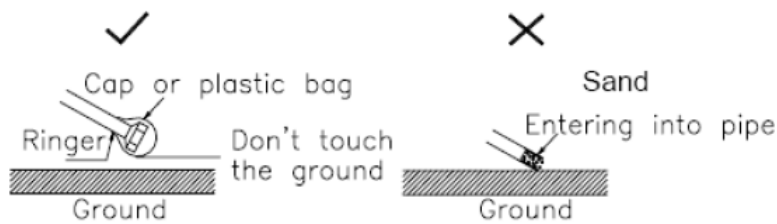

- 7) When conduct piping on a raining day, remember to seal the openings of the pipe first.

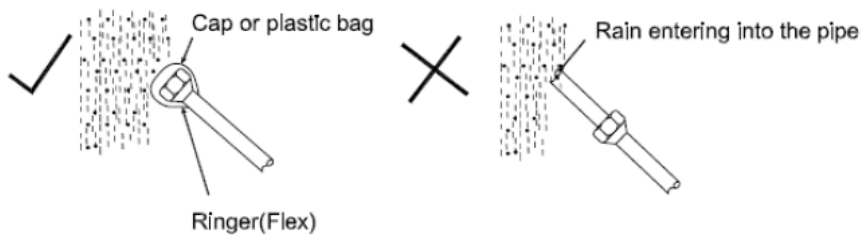

3.1.3 Processing of copper pipe

3.1.3.1. Pipe cutting

1. Tool

Use a pipe cutter instead of a saw or cutting machine to cut the pipe.

2. Correct operation procedure:

Rotate the pipe evenly and slowly, and apply force to it. Cut the pipe off while ensuring that it does not deform.

3. Risk if a saw or cutting machine is used to cut pipe:

Copper chip will enter the pipe (in this case, it will be very hard to clean up), or which may even enter the compressor or blocking the throttling unit.

3.1.3.2. Rectify opening of copper pipe

1. Purpose

Clear out the burr at the opening of the copper pipe, clean the inside of the pipe, and rectify the opening of the pipe, so as to avoid scratch at the opening to be sealed during flaring.

2. Operation procedure

- 1) Use a scraper to remove the inner spurs. When doing so, keep the opening of the pipe downwards to avoid copper chip from entering the pipe.
- 2) After the chamfering is completed, use veiling to remove the copper chip out of the pipe.
- 3) Ensure no scar of produced, so as to avoid the pipe from getting broken during flaring.
- 4) If the pipe end obviously deforms, cut the end off and then cut the pipe again.

3.1.3.3. Pipe expansion

1. Purpose: Expand the opening of the pipe so that another copper pipe can be inserted to replace direct connection and reduce welding spots.

2. Highlight: Ensure that the connection part is smooth and even; after cutting the pipe off, remove the inner spurs.

3. Operation method: Insert the expanding header of the pipe expander into the pipe to expand the pipe. After completing pipe expansion, rotate the copper pipe a small angle to rectify the straight line scratch left by the expanding header.

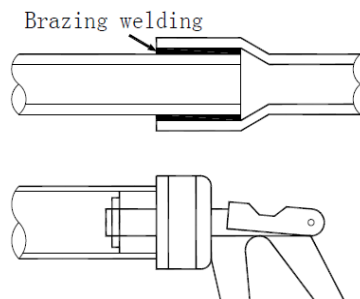

3.1.3.4. Opening bell-mouthed opening

1. Purpose: Flaring Bell-mouthed opening is used for screw thread connection.

2. Highlight:

- 1) Before performing the Bell-mouthed opening operation, perform fire annealing for the hard pipe.
- 2) Use pipe cutter to cut pipe to ensure even cross section and avoid refrigerant leakage; do not use a steel saw or metal cutting device to cut pipe, otherwise the cross section will get deformed and the copper chip will enter the pipe.
- 3) Remove burr carefully to avoid scar on the bell-mouthed opening, which may lead to refrigerant leakage.
- 4) When connecting pipes, use two spanners (one torque wrench and one non-adjustable spanner).
- 5) Before conducting opening bell-mouthed, install pipe onto the flaring nut.
- 6) Use proper torque to tighten the flaring nut.

Pipe Diameter	Torque		Legend
	(kgf-cm)	(N-cm)	
1/4" (6.35)	144~176	1420~1720	
3/8" (9.52)	333~407	3270~3990	
1/2" (12.7)	504~616	4950~6030	
5/8" (15.88)	630~770	6180~7540	
3/4" (19.05)	990~1210	9270~11860	

Caution: When you are tightening the flaring nut with a spanner, the tightening torque will be suddenly increased at a certain point. From this point, further tighten the flaring nut to the angles shown below.

Pipe Diameter	Angle of further tightening	Recommended length of tool lever
3/8" (9.52)	60°~90°	About 200mm
1/2" (12.7)	30°~60°	About 250mm
5/8" (15.88)	30°~60°	About 300mm

7) Check whether the surface of the flaring opening is damaged. The size of the flaring opening is as shown below.

Pipe Diameter	R410A	Legend
	Size of Flaring Opening (A)	
1/4" (6.35)	8.7~9.1	
3/8" (9.52)	12.8~13.2	
1/2" (12.7)	16.2~16.6	
5/8" (15.88)	19.3~19.7	
3/4" (19.05)	23.6~24.0	

Cautions:

- a. Apply some refrigeration oil onto the inner surface and outer surface of the flaring opening, to facilitate the connection or rotation of the flaring nut, ensure close sticking between the sealing surface and the bearing surface, and avoid pipe bending.
- b. Ensure that the flaring opening is not cracked or deformed, otherwise it cannot be sealed or, after the system runs for some time, refrigerant leakage will occur.

3.1.3.5. Pipe bending

1. Method

- 1) Manual bending: Suitable for thin copper pipes (φ6.35-φ12.7).
- 2) Mechanical bending: Suitable in a wide range of copper pipes (φ6.35-φ67). Spring bender, manual bender or electric bender is used.

Purpose: Reduce welding joints and required elbows, and improve engineering quality; In order to save material, no joint is needed.

2. Caution

- 1) When bending a copper pipe, ensure that there is no twinkle or deformation on the inner side of the pipe.
- 2) When using a spring bender, ensure that the bender is clean before inserting it in the copper pipe.
- 3) When using a spring bender, ensure that the bending angle does not exceed 90°, otherwise twinkle will

appear on the inner side of the pipe, and the pipe may easily get broken.

4) Ensure that the pipe does not sink during the bending process; ensure that the cross section of the bending pipe is larger than 2/3 of the original area, otherwise it cannot be used.

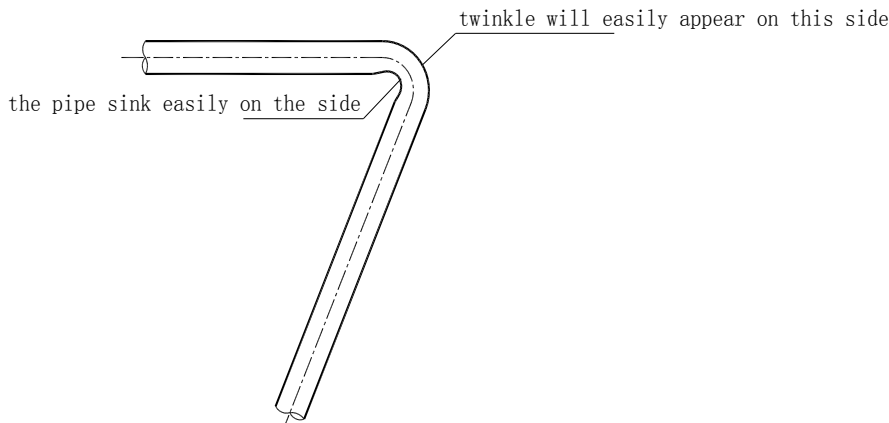

3.1.4 Brazing welding operation

3.1.4.1. Selecting refrigerant pipe

1. All pipe use shall comply with national or local standards (for example, pipe diameter, material, thickness, etc.)
2. Specification: Seamless phosphorus to oxygenate copper pipe
3. Try best to use straight pipe or coil and avoid too much brazing welding.

Note: Select the pipes according to the pipe diameters shown below (O—coil, 1/2H—straight pipe)

Outer Diameter	Material	Minimum Thickness	Outer Diameter	Material	Minimum Thickness	Outer Diameter	Material	Minimum Thickness
Φ6.35	O	0.8	Φ19.0	O	1.0	Φ38.0	1/2H	1.5
Φ9.52	O	0.8	Φ22.0	1/2H	1.2	Φ45.0	1/2H	1.5
Φ12.7	O	0.8	Φ25.0	1/2H	1.2	Φ54.0	1/2H	1.8
Φ15.9	O	1.0	Φ28.6	1/2H	1.3	Φ67.0	1/2H	1.8

3.1.4.2. Nitrogen filling for protecting copper pipe during brazing welding

1. Purpose: Avoid oxide scale from appearing on the inner wall of the copper pipe in the high temp.
2. Risks of non-protective welding:

If no sufficient nitrogen is charged into the refrigerant pipe being welded, oxides will be generated on the inner wall of the copper pipe. These oxides will block the refrigerant system, which will lead to all kinds of malfunctions such as burn-out the compressor, poor cooling efficiency.

To avoid these problems, charge nitrogen continuously into the refrigerant pipe during the brazing welding, and ensure that the nitrogen passes through the operating point until the welding is completed and the copper pipe cools down completely. The schematic diagram for nitrogen charging is shown below.

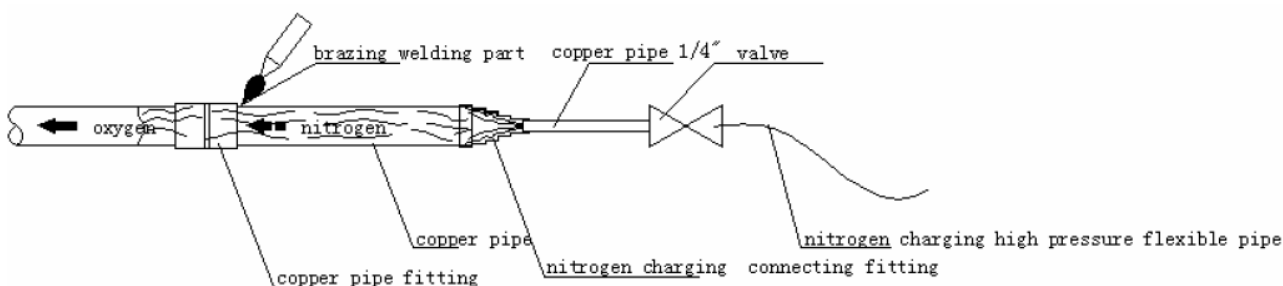

3. Making Nitrogen-Charging Pipe Joint

When welding the pipe joint, connect the nitrogen-charging joint to the pipe fittings to be welded.

The nitrogen-charging joint is shown below:

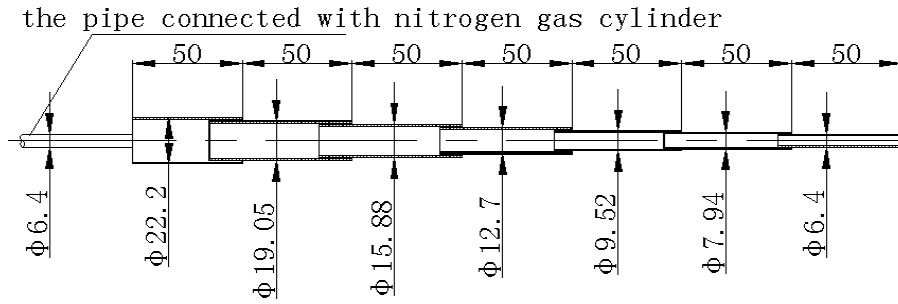

4. Cautions for Welding Pipe Fittings

- 1) Adopt transition pipe.
- 2) Charge nitrogen from the side of the short pipe, because short distance may result in perfectible nitrogen replacement effect.

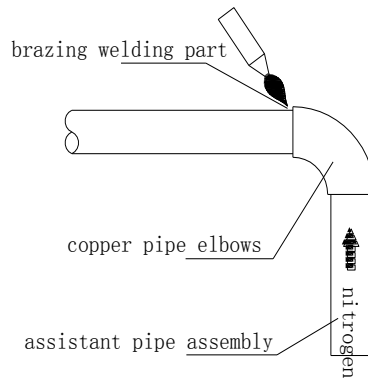
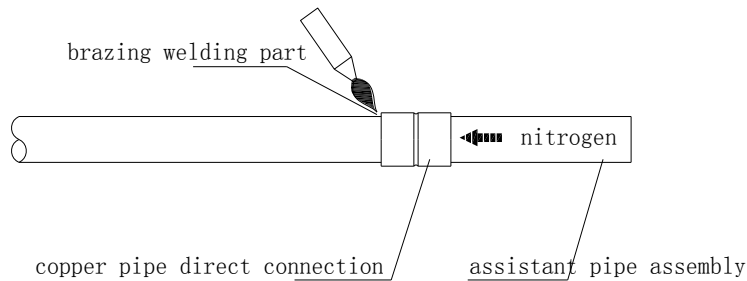

5. Standard operation of Brazing Welding

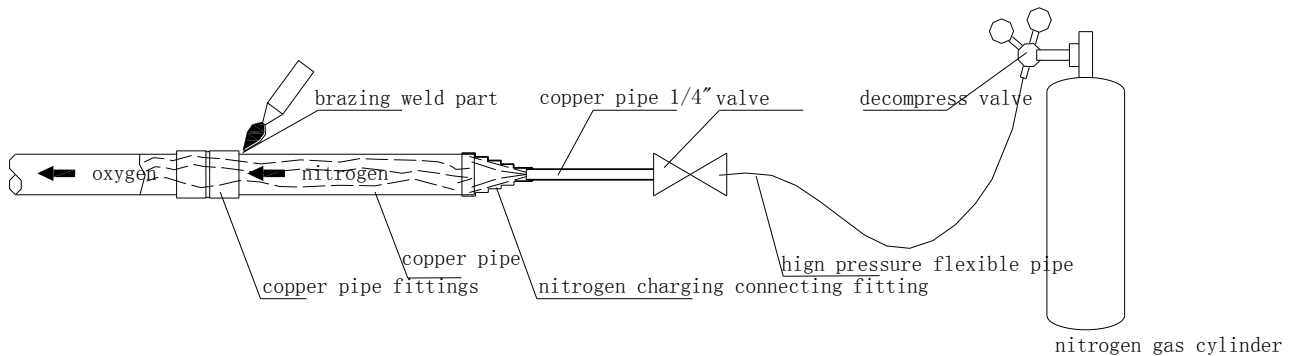

6. Highlight

- 1) Control the nitrogen pressure to be about 0.2-0.3kgf/cm² during the welding.
- 2) Ensure the gas is nitrogen; oxygen will easily leads explosion, so it is forbidden.
- 3) Use pressure reducing valve, and control the pressure of the charged nitrogen to be about 0.2kg/ cm².
- 4) Select a proper position for charging nitrogen.
- 5) Ensure that the nitrogen passes through the welding spots.
- 6) If the pipeline between the position for charging nitrogen and the welding spot is rather long, ensure that the nitrogen is charged for sufficient time so as to discharge all the air from the welding spot.
- 7) After completing the welding, charge the nitrogen continuously until the pipe cools down completely.
- 8) Try best to conduct welding downwards or horizontally and avoid face-down welding.

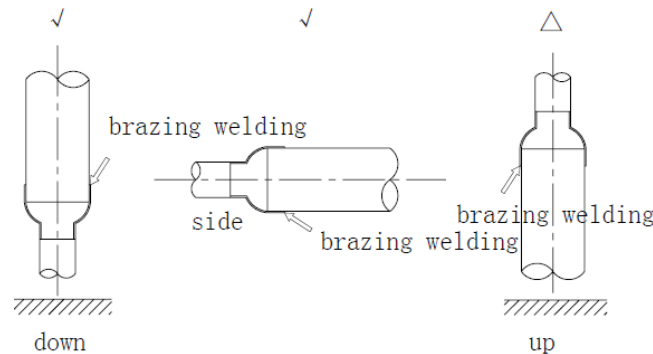

7. Cautions

- 1) Take fire-prevention measures when conducting welding (ensure that a fire extinguisher is available beside the operating position).
- 2) Avoid getting burnt.
- 3) Pay attention to the fit gap of the position where the pipe is inserted.

Note: The follow table shows the relation between the minimum embedded depth and gap at the copper pipe joint.

Type	Outer Diameter of Pipe (D) (mm)+	Minimum Inlaid Depth (B) (mm)	Gap A—D (mm)
	5<D<8	6	0.05—0.21
	8<D<12	7	
	11<D<16	8	0.05—0.27
	16<D<25	10	
	25<D<35	12	0.05—0.35
	35<D<45	14	

3.1.5 Pipe cleaning out

3.1.5.1. Flushing copper pipe

1. Function: use pressure gas to flush pipeline (raw material or welded assembly) for eliminating dust, trash and moisture. Solid impurity is hard to be washed out, so special attention shall be drawn to the protection of copper pipeline during construction.

2. Purpose

- 1) Eliminate oxide powder or part oxide layer in copper pipe.
- 2) Help to clear out dirt and humidity in pipe.

3. Risk in case of no flushing:

If the remaining solid impurity and moisture in pipeline could not be eliminated effectively, serious malfunctions shall happen, such as ice blockage, dirt blockage and compressor being jammed.

3.1.5.2. Procedure of flushing

1. Mounting pressure adjusting valve on nitrogen gas cylinder. The applied gas must be nitrogen. If

adopting polytetrafluoro ethylene or carbon dioxide, there is a risk of condensation. If using oxygen, there is a risk of explosion.

2. Making use of inflation tube to connect outlet of pressure adjusting valve and inlet at liquid pipe side of outdoor unit.

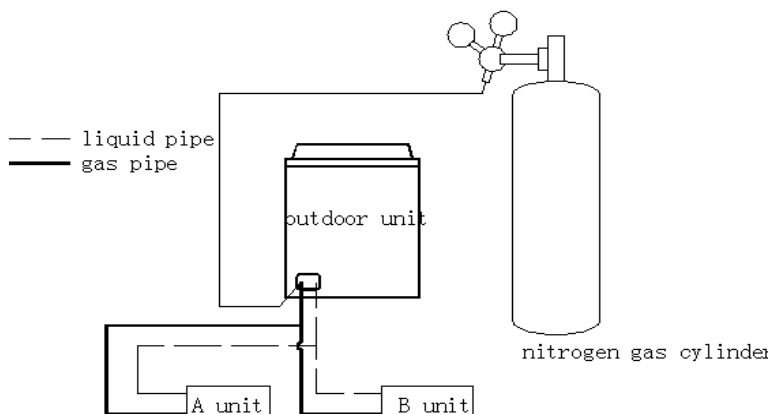

3. Use blind plug to block all connectors of liquid side copper line (including unit B) soundly, excluding indoor unit A.

4. Turn on nitrogen gas cylinder valve, and then pressurize to 5kgf/cm² gradually through adjusting valve.

5. Check whether nitrogen has passed through the liquid pipe at the side of indoor unit A. Connector at the side of indoor unit body has been covered by tape to prevent the entering of dirt.

3.1.5.3. Detailed steps for flushing

1. Hold proper blockage material (such as block bag and white cotton) to push against the main pipe opening at the gas side of indoor unit.

2. When pressure increases and hands could not push against the opening, suddenly release pipe opening (flushing for first time).

Repeat above step1 and step 2 to re-flush dirt (flushing for multi-times)

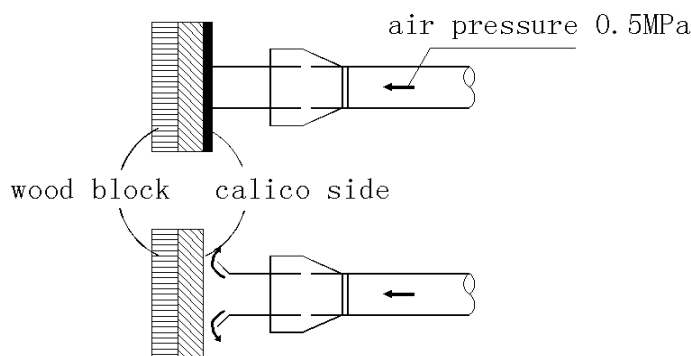

3. During flushing, place a piece of white cotton at the pipe opening for checking, and you shall find some humidity occasionally.

Way of thoroughly drying pipeline is as follows:

1) Making use of nitrogen gas to flush the inner part of pipe until no dirt and humidity.

2) Carry out vacuum drying operation (see vacuum drying of MDV refrigerant piping in detail).

3) Shut down nitrogen main valve.

4) Repeat above operations to the connected copper pipe of all indoor units.

5) Sequence of flushing: when pipeline has been connected to system, sequence of flushing is from far to near, that is, in light of principal unit, flushing from the farthest pipe opening to principal unit in turn (i.e.

1)-2)-3)-4)-5)-6)).

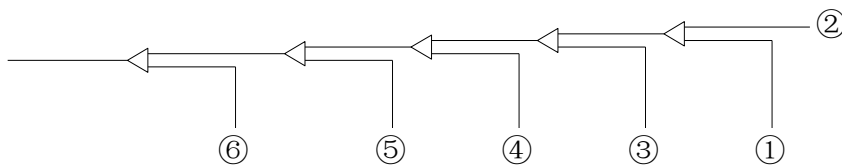

Caution: When flushing one pipe opening, block all pipe openings which are connected to this opening.
 6) After finishing flushing, seal soundly all openings linked with atmosphere to prevent the entering of dust, trash and moisture.

3.2. Air Tight Test

3.2.1 Purpose and operation procedure of air tightness test

3.2.1.1. Purpose

Search leak source, make sure there is no leakage in system to prevent system fault due to leakage of refrigerant.

3.2.1.2. Operation tips

Subsection detection, overall pressure-keeping, grading pressurization.

3.2.1.3. Operation procedure

1. After piping of indoor unit has been connected, weld port of high-pressure side piping.
2. Weld low-pressure side piping with connector for pressure gauge together.
3. Charge nitrogen slowly into pressure gauge connector to conduct air tightness test.
4. After making sure the air tightness test is qualified, weld low-pressure ball valve with low-pressure side piping and connect high-pressure valve with high-pressure side piping.

Note: It must not be allowed to charge nitrogen through ball valve after connecting low-pressure side piping with ball valve, that is, pressurizing ball valve directly is not allowed, otherwise ball valve shall be damaged and nitrogen shall leak into outdoor unit system through the ball valve.

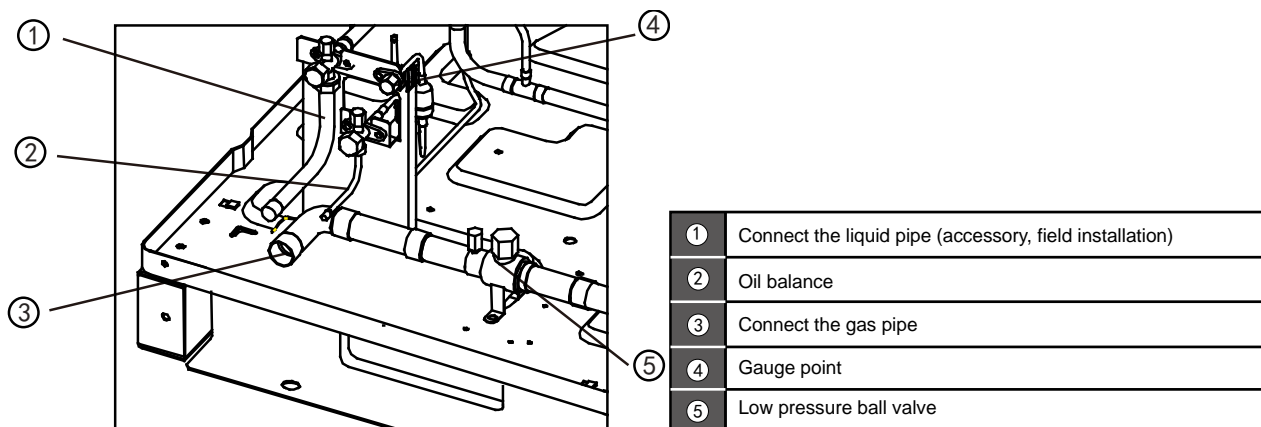

3.2.2 Operation of air tightness test

3.2.2.1. Operation procedure

1. When conducting air tightness test, make sure that gas pipe and liquid pipe are kept in full-shut status; otherwise, nitrogen might enter the circulation system of outdoor unit. Both gas valve and liquid valve need to be strengthened before pressurization d.
2. Each refrigerant system shall be slowly pressurized from the two sides of gas pipe and liquid pipe.
3. Make use of dry nitrogen as medium to conduct air tightness test. Phase-in control diagram of pressurization is as follows:

No.	Phase (phase-in pressurization)	Criteria
1	Phase 1: appear large leakage after over three minutes of pressurization with 3.0kgf/cm ² .	No pressure drop

2	Phase 2: appear major leakage after over three minutes of pressurization with 15.0kgf/cm ² .	after modification
3	Phase 3: appear small leakage after over 24 hours of pressurization with R410A: 40.0kgf/cm ² .	

3.2.2.2. Pressure observation

1. Pressurize to regulated value and maintain 24 hours. When modifying pressure according to variation of temperature, it is qualified if pressure drop does not happen. If pressure falls, find out the leak source and modify it.

2. Modification method

When ambient temperature difference is $\pm 1^{\circ}\text{C}$, the pressure difference shall be $\pm 0.1 \text{ kgf/cm}^2$.

Modification formula: Real value = pressure of pressurization + (temperature of pressurization – temperature during observation) $\times 0.1 \text{ kgf/cm}^2$

You can find out whether the pressure drops or not by comparing the modification value with pressurization value.

3. General ways for searching leak source

Conduct detection through three phases; find out leak source when pressure drop happens.

- 1) Audition detection-----hear large leakage sound
- 2) Hand-touching detection-----place hand at the joint of pipeline to feel whether there is leakage
- 3) Soap water detection-----bubbles shall burst out from leak source.
- 4) Detection by use of halogen leak detector

Using halogen leak detector when finding out pressure drop but not finding the leak source.

a. Keep nitrogen at 3.0kgf/cm².

b. Supplement refrigerant to 5.0kgf/cm².

c. Use halogen leak detector, methane leak detector and electric leak detector for detection.

d. If the leak source still could not be found, continuously pressurize to 40.0kgf/cm² (R410A) and then detect again.

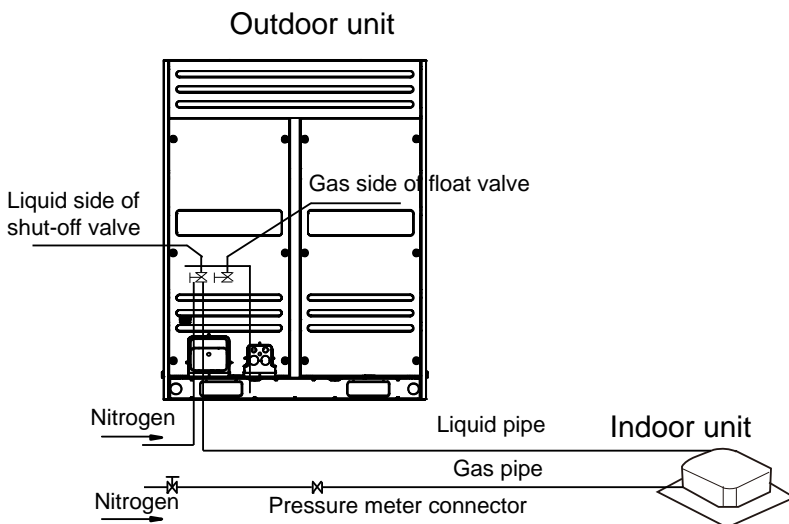

4. Caution

- 1) The air tightness test is conducted by pressurize nitrogen (R410A system: 40kgf/cm²).
- 2) It is not allowed to adopt oxide, flammable gas and toxic gas to conduct air tightness test.
- 3) Before pressure-keeping reading, let it rest for several minutes till pressure is stable, to record temperature, pressure value for future modification.
- 4) After pressure-keeping is over, release system pressure to 5~8 kgf/cm² and then conduct pressure-keeping and storage.
- 5) If pipeline is too long, conduct phase-in detection.
 - a. Inner side of pipeline

- b. Inner side of pipeline + upright
- c. Inner side of pipeline + upright+ outer side of pipeline

3.3. Vacuum Drying

3.3.1 Purpose and highlights of vacuum drying

3.3.1.1. Purpose of vacuum drying

1. Dehumidify the system to prevent ice-blockage and copperizing. Ice-blockage shall cause abnormal operation, while copperizing shall damage compressor.
2. Eliminating the non-condensable gas of system to prevent oxidizing components, system pressure fluctuation, and bad heat exchanging during the system operation.
3. Detect leak source from reverse rotate.

3.3.1.2. Selection of vacuum pump

1. The limit of vacuum degree is below -756mmHg.
2. The discharge of vacuum pump is over4L/s.
3. The precision of vacuum pump is over 0. 02mmHg.

Highlights of R410A system:

After the vacuum process of R410Arefrigerant circulation is over, vacuum pump stops running and the lubricant in vacuum pump shall flow back to air conditioning system, for the inner of pump soft pipe is in vacuum status. In addition, same situation shall happen if vacuum pump suddenly stops during operation. At this moment, different oils will mix, which induce the refrigerant circulating system to malfunction, so it is recommended to use one-way valve to prevent reverse flow of oil in vacuum pump.

3.3.1.3. Vacuum drying for pipe

Vacuum drying: Use vacuum pump to make the moisture (liquid) in pipeline change into steam, which will eliminate the moist of the pipeline and keep drying of pipe inner. Under atmospheric pressure, water’s boiling point(steam temperature) is 100°C, while its boiling point will decline when using vacuum pump reduce the pipeline pressure to vacuum. When the boiling point declines under outdoor temperature, moisture in pipe shall be evaporated.

Boiling Point of Water (°C)	Air Pressure (mmHg)	Vacuum Degree (mmHg)	Boiling Point of Water (°C)	Air Pressure (mmHg)	Vacuum Degree (mmHg)
40	55	-705	17. 8	15	-745
30	36	-724	15	13	-747
26. 7	25	-735	11. 7	10	-750
24. 4	23	-737	7. 2	8	-752
22. 2	20	-740	0	5	-755
20. 6	18	-742			

3.3.2 Operation procedure for vacuum drying

3.3.2.1. Methods of vacuum drying

By different construction environment, there are two kinds of vacuum drying ways: ordinary vacuum drying and special vacuum drying.

3.3.2.1.1. Ordinary vacuum drying

- 1) Firstly, connect the pressure gauge to the infusing mouth of gas pipe and liquid pipe, keep vacuum pump running for above 2 hours, and it is quality that vacuum degree of vacuum pump is below -755mmHg.
- 2) If the vacuum degree of vacuum pump could not be below -755mmHg after 2 hours of drying, system will continue drying for one hour.
- 3) If the vacuum degree of vacuum pump could not be below -755mmHg after 3 hours of drying, please check the system leakage source.

4) Vacuum placement test: when the vacuum degree reaches -755mmHg , keep rest for 1 hour. If the indicator of vacuum gauge does not go up, it is qualified. If going up, it indicates that there is moisture and leak source.

5) Vacuum drying shall be conduct from liquid pipe and gas pipe simultaneously. There are a lot of functional parts like valves, which could shut down the gas flow midway.

3.3.2.1.2. Special vacuum drying

This kind of vacuum drying method shall be adopted when:

- 1) Finding moisture during flushing refrigerant pipe.
- 2) Conducting construction on rainy day, because rain water might penetrated into pipeline.
- 3) Construction period is long, and rain water might penetrated into pipeline.
- 4) Rain water might penetrate into pipeline during construction.

Procedures of special vacuum drying are as follows:

- a. The first vacuum drying 2 hours.
- b. The second vacuum damage, filling nitrogen to 0.5Kgf/cm^2 .

Because nitrogen is dry gas, vacuum damage could achieve the effect of vacuum drying, but this method could not achieve drying thoroughly when there is too much moisture. Therefore, special attention shall be drawn to prevent the entering of water and the formation of condensate water.

- c. The second vacuum drying 1 hour.

It is qualified when vacuum degree is under -755mmHg ; if the vacuum degree is still above -755mmHg within 2 hours drying, please repeat the procedures of "vacuum damage---vacuum drying".

d. Vacuum placement test: when the vacuum degree reaches -755mmHg , keep rest for 1 hour. If the indicator of vacuum gauge does not go up, it is qualified. If going up, it indicates that there is moisture and leak source.

3.4. Recharged of Refrigerant

3.4.1 Operation procedure for recharging refrigerant

3.4.1.1. Operation procedure

Calculate the required refrigerant volume by the length of liquid pipe → recharging refrigerant.

※The refrigerant volume from factory does not include the recharged amount of the pipeline extending.

3.4.1.2. Detailed steps for recharging refrigerant

1. Make sure vacuum drying is qualified before recharging refrigerant.
2. Calculate the required refrigerant volume by the dia. and the length of liquid pipe.
3. Use electronic scale or fluid infusion apparatus to weight there charged refrigerant volume.
4. Use soft pipe to connect refrigerant cylinder, pressure gauge, and examine valve of outdoor unit. And recharge with liquid mode. Before recharging, eliminate the air in the soft pipe and pressure gauge's pipe.
5. After finishing the recharging, by the gas leak detector or soap water, to detect whether there is refrigerant leakage in expansion part of indoor and outdoor units.
6. Write the recharged refrigerant volume in the indicating plate of outdoor unit.

Caution

- 1) The recharged refrigerant volume must be calculated according to the formula in the technical reference of outdoor unit. It isn't allowed to calculate by running current, pressure and temperature. Because current and pressure is changeable due to the difference of temperature and length of pipeline.
- 2) In the cold ambient, use warm water and hot wind to warm up refrigerant storage cylinder, and don't allow heating up directly by flame.

3.4.1.3. Recharging of R410A refrigerant

If R410A refrigerant is adopted, the tool shall be different. Confirm the following items before Recharged:

- 1)The different vacuum pump with one-way valve.
- 2)The different pressure gauge: the nut of connector and pressure scale are different.
- 3)The different recharging soft pipe and connector.
- 4)The charging method is different. Recharge into the outdoor unit with liquid phase.
- 5)The different leak detector.

3.4.2 Calculating the recharged refrigerant volume

Calculate the recharged refrigerant volume by the length and dia. of liquid pipe of indoor units

R410A			
Diameter of Liquid Pipe	Equivalent Refrigerant for Pipe Length of 1m (kg/m)	Diameter of Liquid Pipe	Equivalent Refrigerant for Pipe Length of 1m (kg/m)
Φ6.4	0.023	Φ19.1	0.270
Φ9.5	0.060	Φ22.2	0.380
Φ12.7	0.120	Φ25.4	0.520
Φ15.9	0.170	Φ28.6	0.680

Calculating formula (R410A):

The recharged volume: $R \text{ (Kg)} = (L1 \times 0.023 \text{ kg/m}) + (L2 \times 0.060 \text{ kg/m}) + (L3 \times 0.120 \text{ kg/m}) + (L4 \times 0.180 \text{ kg/m}) + (L5 \times 0.270 \text{ kg/m}) + (L6 \times 0.380 \text{ kg/m}) + (L7 \times 0.520 \text{ kg/m}) + (L8 \times 0.680 \text{ kg/m})$

L1: Actual total length of Φ6.4 liquid pipe (m); L2: Actual total length of Φ9.5 liquid pipe (m);

L3: Actual total length of Φ12.7 liquid pipe (m); L4: Actual total length of Φ15.9 liquid pipe (m);

L5: Actual total length of Φ19.1 liquid pipe (m); L6: Actual total length of Φ22.2 liquid pipe (m);

L7: Actual total length of Φ25.4 liquid pipe (m); L8: Actual total length of Φ28.6 liquid pipe (m)

4. Drainage Pipe Engineering

4.1 Installation Highlights of Drainage Pipe

4.1.1. Installation principle of drainage pipe:

- 1) Slope; 2) reasonable pipe diameter; 3) nearby discharge

4.1.2. Installation highlights of drainage pipe:

1. Before installing condensate water pipeline, determine its route and elevation to avoid intersection with other pipelines and ensure slope is smooth and straight.
2. Make sure that the two horizontal fluid pipes shall avoid encountering, and preventing flow backwards and drainage difficulty.

a. Correct connection:

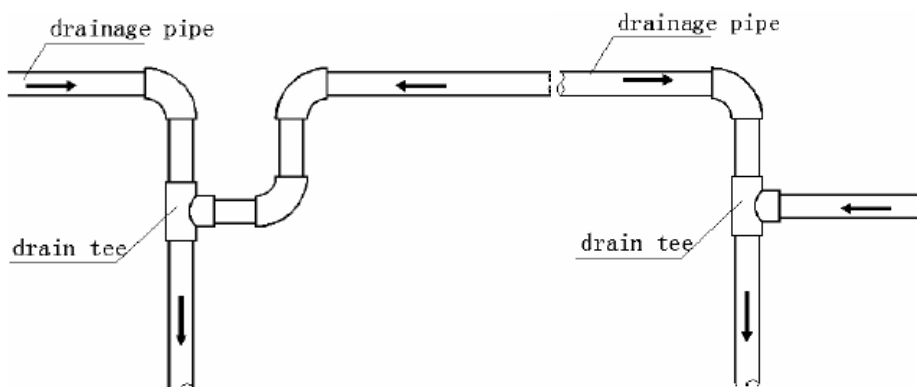

b. Incorrect connection:

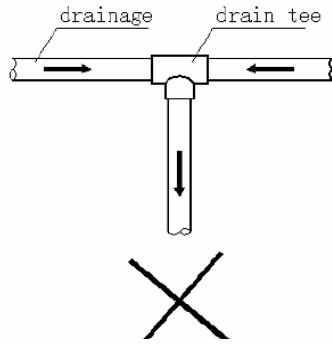

Advantages of correct connection:

1. Do not cause flow backwards of one pipe.
2. The slope of two pipes can be regulated separately.

Disadvantages of incorrect connection:

1. Interfere drainage.
2. The side of branch pipe with large quantity of fluid volume will flow to the side with small quantity, thus leading to the water backwards of branch pipe with small quantity.

3. Suspender gap:

In general, the horizontal gap is 0.8m-1m and the vertical gap is 1.5m-2.0m. Each vertical pipe shall be equipped with not less than two suspenders. Overlarge suspender gap for horizontal pipe shall create bending, thus leading to air resistance.

4. The highest point of drainage pipe shall be designed with air hole to ensure that condensate water could be discharged smoothly. The outlet air hole shall face down to prevent dirt entering pipe.
5. After finishing connection, conduct water passing test and overflowing water test to pipelines to check the smoothness of drainage and leakage of pipeline system.
6. Use specific glue to adhesive the seam of thermal insulation materials, and then bind with rubber or plastics adhesive tape. The width of the adhesive tape shall not be less than 50mm to ensure fastness and prevent condensation.
7. The drainage pipe of air conditioner shall be installed separately with other waste pipe, rainwater pipe and other drainage pipe in building.
8. The slope of drainage pipe shall be kept above 1/100.

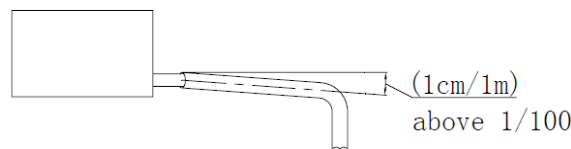

9. In case 1/100 slope can not need, consider to use larger-sized pipe and use its dia. To create slope.
10. Conflux towards horizontal pipe shall come from upside as much as possible. If it comes from transverse route, reflux is easy to be created.

11. The end of drainage pipe shall not contact with ground directly.

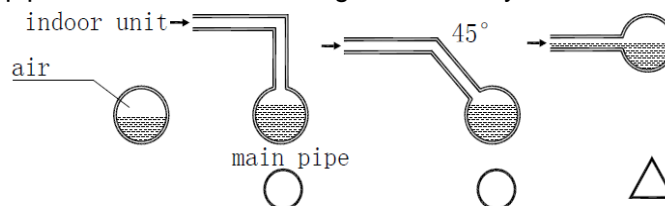

4.1.3. Caution

1. The drainage pipe diameter shall meet the draining requirement of indoor unit.
2. The outlet air vent cannot be installed nearby the lifting pump of the indoor unit.

3. Check whether condensate water pump can be started up and shut down normally by infusing water into the water-containing plate of indoor unit and powering on.
 4. All joints shall be firm (particularly PVC pipe).
 5. The drainage pipe is not allowed to turn to adverse slope, horizontal, and bending.
 6. Dimension of drainage pipe shall be not less than the connecting mouth size of drain piping to indoor unit.
 7. Work out thermal insulation of drainage pipe, otherwise it is easy to produce condensation. Thermal insulation processing shall be continued to the connecting part of indoor unit.
 8. Indoor units with different draining pattern shall not share the same concentrated drainage pipe.
 9. Discharge of condensate water cannot influence normal life and working of other people.
 10. As for long drainage pipe, hanging bolt shall be used to ensure 1/100 slope without bending PVC pipe.
- ✘The support gap of horizontal pipe is 0.8-1.0mm. If the gap is too large, it shall produce bending and air resistance, while air resistance could seriously influence smoothness of water flow to cause abnormal water level. As shown in following figure:

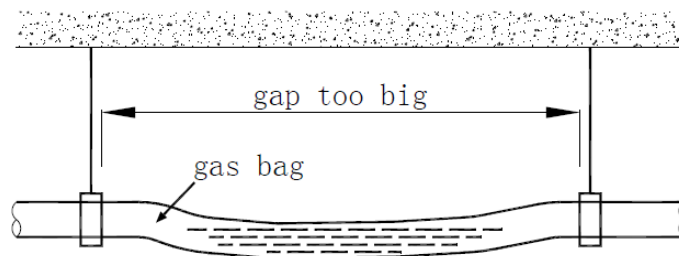

4.2 Water Storing Elbow of Drainage Pipe

4.2.1. To indoor unit with large negative pressure at the outlet of water-containing plate, the drainage pipe must be equipped with water storing elbow.

Function of water storing elbow:

When indoor unit is in motion, prevent generating negative pressure to cause drainage difficulty or blow water out of the air outlet.

Installation of water storing elbow:

1. Install water storing elbow as shown in following figure: H shall be above 50mm.
2. Install one water storing elbow for each unit.
3. When installation, consider it shall be convenient in future clean.

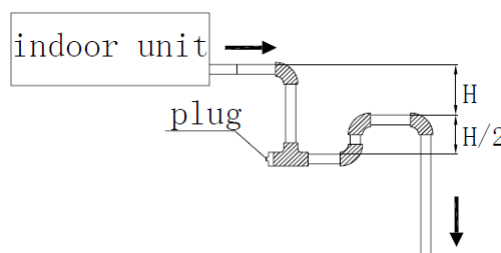

4.3 Concentrated Drainage Pipe

4.3.1. Pipeline diameter of concentrated drainage pipe

Select drainage pipe diameter according to indoor unit's combined flow volume.

E.g.If one 1HP unit with 2L/h discharging condensate water, the calculation of the combined flow volume of three 2HP units and two 1.5HP units is: $2HP \times 2L/h \times 3 + 1.5HP \times 2L/h \times 2 = 18L$

4.3.2. Relation between horizontal pipeline diameter and permitted displacement of condensate water

PVC piping	Inner diameter of piping (reference value: mm)	Inner diameter of piping (mm)	Permitted displacement(l/h)		Remark
			Slope 1:50	Slope 1:100	
PVC25	19	20	39	27	(Reference value) could not used for confluence pipe
PVC32	27	25	70	50	
PVC40	34	31	125	88	Could be used for confluence pipe
PVC50	44	40	247	175	
PVC63	56	51	473	334	

Attention: through converge point need use PVC40 or larger pipe.

4.3.3. Relation between vertical pipeline diameter and displacement of condensate water

PVC piping	Inner diameter of piping (reference value: mm)	Inner diameter of piping (mm)	Permitted displacement(l/h)	Remark
PVC25	19	20	220	(Reference value) could not used for confluence pipe
PVC32	27	25	410	
PVC40	34	31	730	Could be used for confluence pipe
PVC50	44	40	1440	
PVC63	56	51	2760	
PVC75	66	67	5710	
PVC90	79	77	8280	

Attention: through converge point need use PVC40 or larger pipe.

4.3.4. Operation process of concentrated drainage

Install indoor unit → connect drainage pipe → water passing test and overflowing water test → thermal insulation of drainage pipe

Caution:

- 1) Increase drainage point as much as possible and reduce quantity of connected indoor units, to ensure horizontal main drainage pipe not be too long.
- 2) Units with drainage pump and natural drainage shall converge to different drainage system separately.
- 3) Add two elbows at air outlet, and make sure its mouth faces down to prevent dirt and so on dropping into pipe to create blockage.

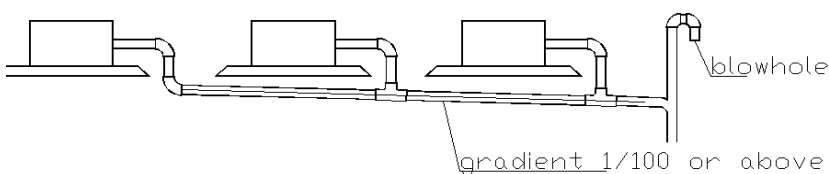

4.4 Lifting of Drainage Pipe (for the Unit with Lift Pump)

4.4.1. Installation of lift pipe

1. When connecting drainage pipe with indoor unit, use pipe clamp shipped with unit to fix. Glue splicing is not permitted for ensuring convenience in repairing.
2. To ensure 1/100 slope, total lift height of drainage pipe (H) shall depend on indoor unit's pump, and do not set vent pipe on the lifting pipe section. After lifting vertically, immediately place down inclined, otherwise it will cause error operation of switch at water pump. The connecting method is shown as

follows:

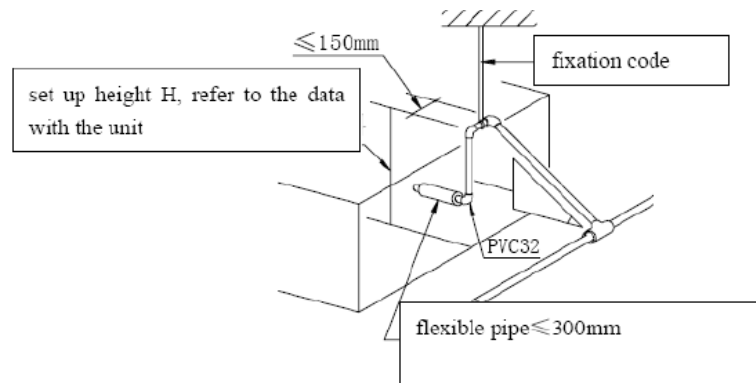

Note: Air outlet could not be installed on the lifting part; otherwise water shall be discharged to ceiling or could not be discharged.

4.5 Overflowing Water Test and Water Passing Test

4.5.1. Overflowing water test

After finishing the construction of drainage pipe system, fill the pipe with water and keep it for 24 hours to check whether there is leakage at joint section.

4.5.2. Water passing test

1. Natural drainage mode

Infuse water-containing plate with above 600ml water through check port slowly, and observe transparent hard pipe at drainage outlet to confirm whether it can discharge water.

2. Pump drainage mode

1) Remove plug of water level switch, remove water-finding cover and slowly infuse water-containing plate with about 2000ml water through water-finding port to prevent touching the motor of drainage pump.

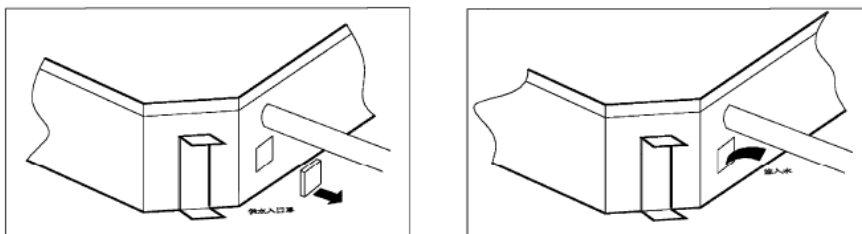

2) Power on and let the air conditioner operate for cooling. Check operation status of drainage pump, and then turn on water level switch, check operation sound of pump and observe transparent hard pipe at drainage outlet to confirm whether it can discharge water. (In light of the length of drainage pipe, water shall be discharged after delaying about 1 minute)

3) Stop the operation of air conditioner, turn down power supply and put water-finding cover to the original place.

a. After stopping the operation of air conditioner, check whether there is something abnormal 3 minutes later. If drainage pipe have not been distributed properly, over back-flow water shall cause the flashing of alarm indicator at remote-controlled receiving board and even water shall run over the water-containing plate.

b. Continuously add water until reaching alarm water level, check whether the drainage pump could discharge water at once. If water level does not decline under warning water level 3 minutes later, it shall cause shutdown of unit. When this situation happens, normal startup shall be carried out by turning down power supply and eliminating accumulated water.

Note: Drain plug at the main water-containing plate is used for eliminating accumulated water in

water-containing plate when maintaining air conditioner fault. During normal operation, the plug shall be filled in to prevent leakage.

5. Duct Engineering

5.1. Fabrication of Duct

1. The material, specification, performance and thickness of metal duct should be in accordance with the relevant regulations of present National Products Standard. The thickness of steel sheet or galvanized steel sheet should not be less than the regulation in table below:

Thickness of steel sheet duct (mm)

Diameter (D) or edge length (b) of duct	Circular duct	Rectangle duct	
		Middle/low pressure system	High pressure system
$D(b) \leq 320$	0.5	0.5	0.75
$320 < D(b) \leq 450$	0.6	0.6	0.75
$450 < D(b) \leq 630$	0.75	0.6	0.75
$630 < D(b) \leq 1000$	0.75	0.75	1.0
$1000 < D(b) \leq 1250$	1.0	1.0	1.0

2. The material, specification, performance and thickness of non-metal duct should be in compliance with design and regulations of present National Products Standard.

3. The body, frame, fixing material and sealed cushion of fire-proof air duct should be made of non-combustible materials. Its fire resistance rating should be in accordance with the design requirement.

4. The sheathing of composite duct should be made of non-combustible materials. Inner insulation material should be no burning or burning retardant with rating B1, and no harm to people's body.

5. The permitting deviation to outer diameter or long edge of duct: when no more than 300mm, it is 2mm; when more than 300mm, it is 3mm. The permitting deviation of pipe end flatness is 2mm.

Discrepancy between two diagonal lines of rectangle duct shall not be more than 3mm. Discrepancy between two diameters of any cross-cut circular flange shall not be more than 2mm.

5.2. Connection of Duct

1. Connection of metal duct

1) The seam of duct board splice should be stagger and cross-seam is not allowed.

2) Specification of metal duct flange shall not be less than the data as shown in table below.

Specification to flange and bolt of circular metal duct (mm)

Diameter of duct (D)	Specification of flange		Specification of bolt
	Flat steel	Angle steel	
$D \leq 140$	20 × 4	—	M6
$140 < D \leq 280$	25 × 4	—	
$280 < D \leq 630$	—	25 × 3	
$630 < D \leq 1250$	—	30 × 4	M8
$1250 < D \leq 2000$	—	40 × 4	

Specification to flange and bolt of rectangle metal duct (mm)

Dimension of long edge of duct (b)	Specification of flange (angle steel)	Specification of bolt
$B \leq 630$	25 × 3	M6
$630 < b \leq 1500$	30 × 3	M8
	40 × 4	
$2500 < b \leq 4000$	50 × 5	M10

3) Diameter of bolt and rivet to duct flange for middle/low pressure system should be no more than 150mm.

As for duct of high pressure system, it should be no more than 100mm.

4) Four angles of rectangle duct flange should be designed with screw hole.

5) When improving the strength of duct flange position by adopting reinforcement method, the applied condition corresponding to flange specification could be extended.

2. Connection of nonmetallic duct

Specification of flange should be in accordance with standard, gap of bolt hole should be no more than 120m. Four angles of rectangle duct flange should be designed with screw hole.

3. Strengthening of metal duct

When edge length of rectangle duct is more than 630mm, edge length of insulation duct is more than 800mm and length of pipe section is more than 1250mm, or single-edge level area of low pressure duct is more than 1.2 square meters and single-edge level area of high/middle pressure duct is more than 1.0 square meter, strengthening measures should be conducted.

4. Strengthening of nonmetallic duct

When diameter or edge length of HPVC duct is more than 500mm, the joint section of duct and flange should be equipped with strengthening board and the gap should not be more than 450mm.

5.3. Connecting Highlights of Duct

1. Supporting, hanging and mounting bracket should be made of angle steel. Position of expansion bolt should be correct, firm and reliable. The buried part could not be painted and oil pollution should be eliminated. Gap should be in accordance with regulation below:

1) If duct is installed horizontally, gap should be no more than 4m when diameter or edge length is less than or equal to 400mm, while the gap should be no more than 3m when diameter or edge length is more than 400mm.

2) If duct is installed vertically, gap should be no more than 4m and make sure there is at least 2 fixed points on single straight pipe.

2. Supporting, hanging and mounting bracket could not be installed at air opening, valve, checking door and automatically controlled device, and distance to air opening or plugged tube shall not be less than 200mm.

3. Hanging bracket should not be hung above flange.

4. Thickness of flange gasket should be 3-5mm. Gasket should be flat on flange and inserting to pipe is not allowed. Set up fixed points at proper place for hanging pipe to prevent vibration.

5. Vertical splice seam of duct should be stagger. Make sure there is no vertical seam at the bottom of duct installed horizontally. As for the installation of flexible short duct, keep proper tightness and no distortion.

6. All metal parts (including supporting, hanging and mounting bracket) on pipeline system engineering should be conducted anti-corrosion treatment.

5.4. Installation of Assembly

1. The regulating device of duct should be installed in place where is easy to operate, flexible and

reliable.

2. The air port should be installed firmly and air pipe should be connected tightly. Frame should be tightly contact with decorate of building. The appearance should be smooth and flat, and regulation is flexible.
3. If air port is installed horizontally, deviation of levelness is no more than 3/1000. If air port is installed vertically, deviation of perpendicular should be no more than 2/1000.
4. The same air port in same room should be installed at the same height, and put in order.

6. Heat Insulation Engineering

The insulation of refrigerating equipment and pipe is carried out through general insulation method, which binding the equipment and pipe with solid multi-hole insulation material and exploiting proper wet-proof and protection measures, called insulation structure. The form of insulation structure shall be different in light of different insulation materials. This is a traditional insulation method which is adopted very early. Although its insulation performance is general, but it is simply in structure, convenient in construction and cheap in price, so that it is widely used in refrigeration engineering.

6.1 Insulation of Refrigerant Piping

6.1.1. Operational procedure of refrigerant piping insulation

Construction of refrigerant pipe → insulation (excluding connecting section) → test for air sealing
→connecting section insulation

Connecting section: for instance, insulation construction just could be carried out after air tightness test at welding area, opening expending area and flange joint is successful.

6.1.2. Purpose of refrigerant piping insulation

1. During operation, temperature of gas pipe and liquid pipe shall be over-heating or over-cooling extremely. Therefore, it is necessary to carry out insulation; otherwise it shall reduce the performance of unit and burn compressor.
2. Gas pipe temperature is very low during cooling. If insulation is not enough, it shall form dew and cause leakage.
3. Temperature of outlet pipe (gas pipe) is very high (generally 50-100°C) during heating. Touching due to carelessness shall cause hurt, so it is necessary to take insulation measures to avoid getting hurt.

6.1.3. Selection of insulation materials for refrigerant piping

Adopt hole-closed foam insulation materials with level B1 of burning retardant and over 120°C of constant burning performance.

6.1.4. Thickness of insulation layer

1. When outer diameter of copper pipe (d) is less than or equal to 12.7mm, the thickness of insulation layer (δ) shall be above 15mm.

When outer diameter of copper pipe (d) is more than or equal to 15.88mm, the thickness of insulation layer (δ) shall be above 20mm.

2. In hot and wet environment, the above recommended value shall be increased one time.

Note: The outdoor pipeline shall be protected by metal case to proof sunshine, storm and air erosion, and prevent damage of external force or man-made destroy.

6.1.5. Installation and highlights of insulation construction

1. Example of wrong operation: Gas pipe and liquid pipe are carried out insulation together; causing the operation effect of air conditioner is bad.
2. Example of correct operation:
 - a. Gas pipe and liquid pipe are carried out heat insulation separately.

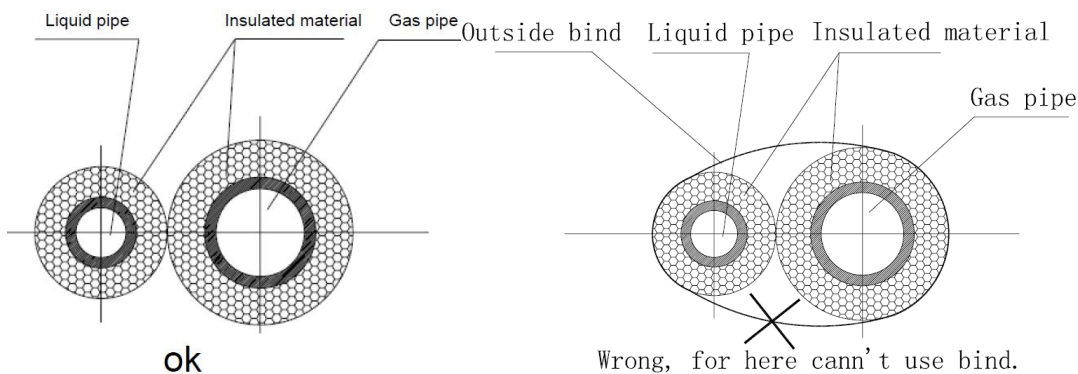

Note: After gas pipe and liquid pipe are carried out heat insulation separately, bind with tape. If it is bound over tightly, the spliced insulation joint shall be damaged.

b. The surrounding of pipe connecting section shall be carried out insulation entirely.

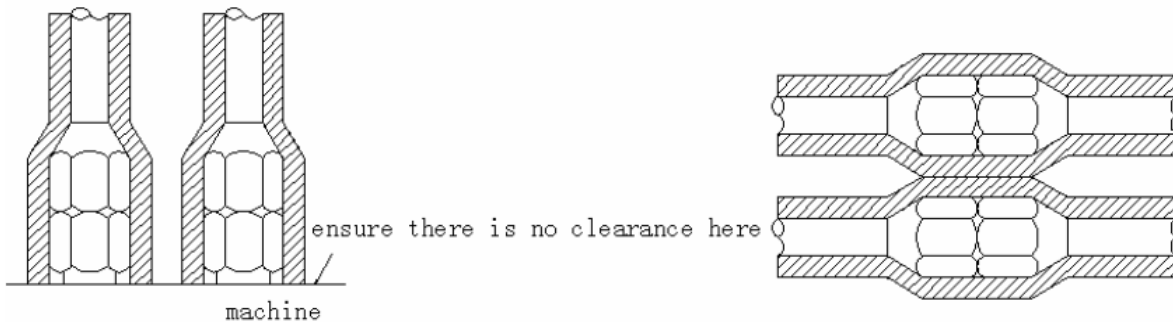

Highlights:

1. No gap in joint of insulation materials.
2. If the joint of insulation materials is linked tardily and tape is bound over tightly, shrinkage and leakage shall be produced easily to create phenomena of dew-drop. The over-tightened tape shall edge out air in material, leading to decrease the insulation effect at this part; meanwhile tape shall be easily aged and drop down.
3. In indoor shield space, it is no necessary to bind belting, so as to avoid influencing insulation effect.

Correct repairing method for insulation cotton: (see the figure below)

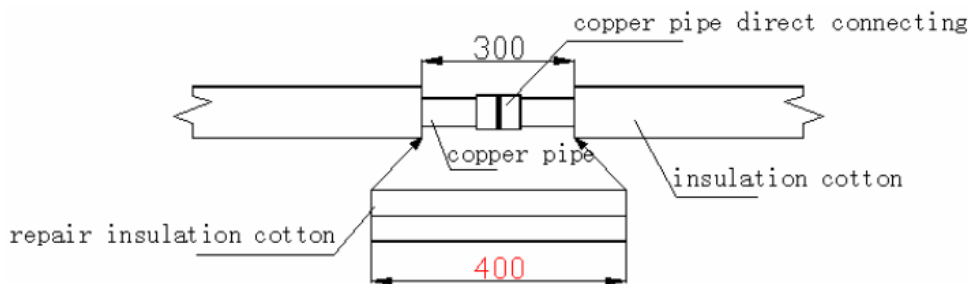

Firstly cut out the material longer than gap, expend the two ends and embed the insulated cotton, at last, paste joint with glue.

Highlights of insulation repairing:

1. Repaired length of insulation (insulation tube with filled gap) shall be 5-10cm longer than the length of gap under natural status.
2. Sliver the cut of insulation to be repaired and cross-section shall be even.
3. Insert gap with insulation for repairing and cross-section shall be pressed tightly.
4. All cross-section and cut need to be pasted with glue.
5. Finally, bind the seam with rubber/plastic tape.
6. Prohibit conducting insulation by using binder fabric in concealed section, so as to avoid influencing insulation effect.

6.2 Insulation of Condensate Water Pipe

6.2.1. Insulation of condensate water pipe

1. Select rubber/plastic tube with burning retardant of rating B1.
2. Thickness of insulation layer is usually above 10mm.
3. The insulation material at water outlet of unit body should be pasted with glue on the unit body, so as to avoid dewing and dripping.
4. Pipe installed in wall shall not be conduct insulation.
5. Use specific glue to paste the seam of insulation material, and then bind with cloth tape. The width of tape shall not be less than 5cm. Make sure it is firm and avoid dewing.

6.3 Insulation of Duct

I. Insulation of duct

1. Insulation of duct parts and equipment should be conducted after confirming that the leakage test and quality of duct is qualified.
2. Usually making use of centrifugal glass cotton, rubber/plastic material or other late-model insulation duct to conduct insulation.
3. Insulation layer should be even and tight. Crack, gap and other defects are not allowed.
4. The supporting, hanging and mounting bracket of duct should be set up to the outside of insulation layer, and insert bed timber between bracket and duct.
5. Thickness of insulation layer
 - 1) As for the inlet and outlet duct installed in room free of air conditioner, the thickness of insulation layer should be above 40mm when adopting centrifugal glass cotton for insulation.
 - 2) As for the inlet and outlet duct installed in room with air conditioner, the thickness of insulation layer should be above 25mm when adopting centrifugal glass cotton for insulation.
 - 3) When adopting rubber/plastic material and other materials, the thickness of insulation layer should become out in accordance with design requirement or calculation.

7. Electrical Engineering

Please refer to “Part 3. Outdoor Units Specification & Performance”.

Highlights of electrical installation

1. Purchased wiring, parts and materials should be in compliance with the local and national regulations.
2. All field wiring construction should be finished by qualified electrician.
3. Air conditioning equipment should be grounded according to the relevant local and national electrical regulations.
4. Current leakage protection switch should be installed (select current leakage breaker in light of the 1.5-2 times of total loading rated current.)
5. When connecting wiring and wire holder, use cable clamp to fix and make sure no exposure.
6. Refrigerant piping system and wiring system of indoor and outdoor unit belongs to the different system.
7. Do not connect the power wire to the terminal of signal wire.
8. When power wire is parallel with signal wire, put wires to their own wire tube and remain proper gap (the current capacity of power wire is: 10A below 300mm, 50A below 500mm).
9. Voltage discrepancy of power wire terminal (side of power transformer) and end voltage (side of unit) should be less than 2%. If its length could not be shortened, thicken the power wire. Voltage discrepancy between phases shall not pass 2% rated value and Current discrepancy between highest and lowest phase should be less than 3% rated value.

Selection of Wiring

1. The selection of wiring area shall in accordance with the requirements below:
 - 1) Voltage lose of wire shall meet the requirement of terminal voltage for normal operation and startup.
 - 2) The wiring current-carrying capacity determined by installed method and environment is not less than the largest current of unit.
 - 3) Wiring shall ensure the stability of movement and heating.
 - 4) The smallest sectional area should satisfy the requirement of mechanical strength.

Sectional area of core to phase line S(mm ²)	Smallest sectional area of PE line (mm ²)
S ≤ 16	S
16 < S ≤ 35	16
S > 35	S/2

When earth protection line (shortly called PE line) is made of material the same as phase line, the smallest sectional area of PE line should be in accordance with the regulation below:

Sectional area of core to phase line S(mm²) Smallest sectional area of PE line (mm²)

Distribution highlights of distribution wiring

1. When distributing wiring, select wirings with different colors for phase line, zero line and protection earth according to relevant regulations.
2. The power wire and control wire of concealed engineering is prohibited to bind together with refrigerant piping. It is necessary to pass through wire tube and be distributed separately, and the gap between control line and power wire should be 500mm at least.
3. When distributing wiring by passing through pipe, the following should be paid attention to:
 - 1) Metal wire tube could be used in indoor and outdoor, but it is not suitable to place with acid - alkali corrosion.
 - 2) Plastic wire tube is generally used in indoor and place with corrosion, but it is not suitable to situation with mechanical damage.
 - 3) The wiring through pipe shall not be in the form with ends jointing. If joint is a must, connection box

should be installed at the corresponding place.

- 4) The wiring with different voltage should not pass through the same wire tube.
- 5) Total sectional area of wiring through wire tube shall not exceed 40% valid area of stuffing tube.
- 6) Fixing point of wire tube support shall follow the standard below:

Nominal diameter of wire tube (mm)	Largest gap between fixed points of wire tube	
	Metal pipe	Plastic pipe
15-20	1.5	1
25-32	2	1.5
40-50	2.5	2

Nominal diameter of wire tube Largest gap between fixed points of wire tube

Control System and Installation

Connecting highlights of control line (RS-485 communication)

- 1. The control line should be shielded wire. Using other wiring shall create signal interference, thus leading to error operation.
 - 2. Single end to shield net of shielded wire should be grounded.
- Note: The shield net should be grounded at the wiring terminal of outdoor unit. The inlet and outlet wire net of indoor communication wire should be connected directly and could not be grounded, and form open circuit at the shield net of final indoor unit.
- 3. Control wire could not be bound together with refrigerant pipeline and power wire. When power wire and control wire is distributed in parallel form, keep gap between them above 300mm so as to preventing signal interference.
 - 4. Control wire could not form closed loop.
 - 5. Control wire has polarity, so be careful when connecting.

8. Commissioning and Trial Running

8.1 Work before Commissioning

8.1.1. Inspection and confirmation before Commissioning

- 1. Check and confirm that refrigeration pipe line and communication wire with indoor and outdoor unit have been connected to the same refrigeration system. Otherwise, operation troubles shall happen.
- 2. Power voltage is within ±10% of rated voltage.
- 3. Check and confirm that the power wire and control wire are correctly connected.
- 4. Check whether wire controller is properly connected.
- 5. Before powering on, confirm there is no short circuit to each line.
- 6. Check whether all units have passed nitrogen pressure-keeping test for 24 hours with R410A: 40kg/cm².
- 7. Confirm whether the system to Commissioning has been carried out vacuum drying and packed with refrigeration as required.

8.1.2. Preparation before Commissioning

- 1. Calculating the additional refrigerant quantity for each set of unit according to the actual length of liquid pipe.
- 2. Keep required refrigerant ready.
- 3. Keep system plan, system piping diagram and control wiring diagram ready.
- 4. Record the setting address code on the system plan.
- 5. Turn on power switches outdoor unit in advance, and keep connected for above 12 hours so that heater heating up refrigerant oil in compressor.
- 6. Turn on gas pipe stop valve, liquid pipe stop valve, oil balance valve and gas balance valve totally. If the above valves do not be turned on totally, the unit should be damaged.

7. Check whether the power phase sequence of outdoor unit is correct.
8. All dial switches to indoor and outdoor unit have been set according to the Technical Requirement of Product.

8.2 Commissioning of Trial Run

8.2.1. Commissioning for trial run of single unit.

1. Each independent refrigeration system (i.e. each outdoor unit) should be conducted trial operation.
2. Detection details of trial run:
 - 1) As for fan in unit, make sure the rotating route of its impeller is correct and impeller turns around smoothly. No abnormal vibration and noise.
 - 2) Check whether there is abnormal noise during operation of refrigerant system and compressor.
 - 3) Check outdoor unit whether it can detect each indoor unit.
 - 4) Check whether drainage is smooth and its lift pump can be in motion.
 - 5) Check whether microcomputer controller can be in motion normally and whether any trouble appears.
 - 6) Check whether operating current is within the allowed range.
 - 7) Check whether each operating parameter is within the range permitted by the equipment.

Note: When conducting trial run, separately test cooling mode and heating mode to judge the stability and reliability of system.

The commissioning report form is shown as follows:

Commissioning Report for MDV System

Date:

Item name:	
Address:	Tel:
Supplier:	Delivery date:
Installation section:	Principal:
Commissioning section:	Principal:
<p>Remark: recharged refrigeration quantity to system: kg</p> <p style="text-align: center;">Name of refrigerant: (R410A)</p>	

Installing section:
(seal)

Commissioning name:
(seal)

Signature:

Signature:

Date: _____

Date: _____

Test Data for Test Run of _____ System

Model of outdoor unit	Production series no.

Operation data of outdoor unit (Cooling)

Unit	No.1	No.2	No.3
Run Voltage V			
Total current of run A			
Operation current of compressor A			
High-pressure pressure Kg/cm ²			
Low-pressure pressure Kg/cm ²			
Inlet air temperature□°C			
Outlet air temperature°C			

Operation data of indoor unit

No.	Position	Model	Bar code of indoor unit	Inlet air temperature°C	Outlet air temperature°C
1					
2					
3					
4					
5					
6					
7					
8					
9					
10					
11					
12					
13					
14					
15					
16					

System parameter

SW1 : Used to query outdoor unit data.

Check point sequence and corresponding actuality is as follows:

SW2 : Used to query outdoor unit data. (18-20PH)

Check point sequence and corresponding actuality is as follows:

The 18HP-20HP Type:

No.	Normal Display	Content	Note	No.	Display content	Content	Note
0	0.--	ADDR of outdoor unit	0	14	4.--	Discharge temp, No.1 fixed compressor	Actual Value
1	1.--	Outdoor unit itself capacity	18,20	15	5.--	Discharge temp, No.2 fixed compressor	Actual Value
2	2.--	Qty. of outdoor unit	Effective to main unit	16	6.--	Discharge temp, No.3 fixed compressor	Actual Value
3	3.--	Total capacity of outdoor unit	Capacity requirement	17	7.--	Current, inverter compressor	Actual Value
4	4.--	Cap. REQT. of indoor units	Available for main unit	18	8.--	Current, No.1 fixed compressor	Actual Value
5	5.--	Cap. REQT. of main unit (after correction)	Available for main unit	19	9.--	Current, No.2 fixed compressor	Actual Value
6	6.--	Running mode	0,1,2,3,4	20	0.--	Current, No.3 fixed compressor	Actual Value
7	7.--	Actual running cap. of outdoor unit	Capacity requirement	21	1.--	Discharge pressure	Actual value × 0.1MPa
8	8.--	Fan speed	0,1,2,3,4,5,6	22	2.--	Opening degree, EXV A	Actual value × 8
9	9.--	T2 average temp	Actual value	23	3.--	Opening degree, EXV B	Actual value × 8
10	0.--	T3 pipe temp	Actual value	24	4.--	Qty. of indoor unit	Actual Value
11	1.--	RESERVE	/	25	5.--	The last error or protection code	No protection or error, display 00
12	2.--	T4 ambient temp	Actual value	26	6.--	--	Check end
13	3.--	Discharge temp, inverter compressor	Actual value				

Remark:

1) Normal display:

Display qty. of indoor units which could communicate with outdoor unit on standby mode. In case of cap.

Requirement, display running frequency of the inverter compressor.

2) Running mode:

0--OFF/FAN; 2--COOL; 3--HEAT; 4--Constraint cool

Fan speed: 0--left and right OFF; 1--left off and right low; 2--left off and

right high; 3--left low and right off; 4--left high and right off;

5--left low and right low; 6--left high and right high

3) ENC1:Outdoor unit capacity setting switch

ENC2:Outdoor unit address setting switch

ENC3: Network ADDR setting switch

SW1: constraint cool button

SW2: query button

The 30HP Type:

No.	Normal Display	Content	Note	No.	Display content	Content	Note
0	1.--	ADDR of outdoor unit	0	16	7.--	Discharge temp, No.4 fixed compressor	Actual value
1	2.--	Cap. of outdoor unit	28, 30, 32	17	8.--	Discharge temp, No.5 fixed compressor	Actual value
2	3.--	Qty. of outdoor unit	Effective to main unit	18	9.--	Current, inverter compressor	Actual value
3	4.--	Total cap. of outdoor units	Capacity requirement	19	0.--	Current, No.1 fixed compressor	Actual value
4	5.--	Cap. REQT. of indoor units	Effective to main unit	20	1.--	Current, No.2 fixed compressor	Actual value
5	6.--	Cap. REQT. of main unit (after correction)	Effective to main unit	21	2.--	Current, No.3 fixed compressor	Actual value
6	7.--	Running mode	0, 1, 2, 3, 4	22	3.--	Current, No.4 fixed compressor	Actual value
7	8.--	Actual running cap. of outdoor unit	Capacity requirement	23	4.--	Current, No.5 fixed compressor	Actual value
8	9.--	Fan speed	A/B:0, 1, 2, 3, 4, 5, 6, 7, 8, 9	24	5.--	Discharged pressure	Actual value ×0.1MPa
9	0.--	T2/T2B average	Actual value	25	6.--	Opening degree,	Actual value

						EXV A、C	×8
10	1.--	T3 pipe temp	Actual value	26	7.--	Opening degree, EXV B、D	Actual value ×8
11	2.--	T4 ambient temp	Actual value	27	8.--	The limitation of Indoor unit proformed mode	0, 1, 2, 3, 4
12	3.--	Discharge temp, inverter compressor	Actual value	28	9.--	Qty. of indoor unit	Actual value
13	4.--	Discharge temp, No.1 fixed compressor	Actual value	29	0.--	The last error or protection code	No protection or error display 00
14	5.--	Discharge temp, No.2 fixed compressor	Actual value	30	-----	--	Check end
15	6.--	Discharge temp, No.3 fixed compressor	Actual value				

Remarks:

1) Normal display:

Display qty. of indoor units which could communicate with outdoor unit on standby mode. In case of cap. requirement, display running frequency of the inverter compressor.

2) Running mode:

0--OFF/FAN; 2--COOL; 3--HEAT; 4--Constraint cool

3) Fan speed:

0-fan stop;

1~9 speed increase sequentially;

9 is the max. fan speed.

PMV opening: pulse count=displayed value×8

ENC3: Network ADDR setting switch

SW1: constraint cool button

SW2: query button

Part 5

Troubleshooting

1. Normal Air Conditioner Phenomenon 1181
2. Air Conditioner Protection in Common..... 1181
3. Malfunction Code and Troubleshooting 119

1. Normal Air Conditioner Phenomenon

1.1 When outdoor unit appears white vapor or water, the reasons is as follows:

- 1) The fan of outdoor unit stops to begin defrosting0.
- 2) The electromagnet valve sends out the noise when the defrosting begins and ends.
- 3) There is sound like water flowing when running or off; and the noise enlarges after running for 3 minutes. This is the sound of refrigerant flowing or discharging water gathered by dehumidifying.

1.2 Outdoor units send out the noise of “pupu”, for temperature changes to heat exchanger heat expanded or cool compact.

1.3 Indoor units send out odor smell, because it absorbs the smell of house, furniture or smoking.

1.4 The running light of indoor unit flickers, the reasons are generally as follows:

- 1) Power supply ever failed during running period.
- 2) For 1-to-several, the following induces the director lighting and the operation stopping
 - ①Other indoor units running at heating mode induce to this indoor unit cannot run at cooling mode
 - ②Setting mode conflicts with the fixed mode.
 - ③ Stop fan to prevent discharging cool air.

1.5 The “no priority” or “waiting” director light of operation board lights.

1.6 Auto running or stopping for the timer wrong operation.

1.7 Cannot run, the reasons are as follows:

- ①Power is off.
- ②Manual switch is pulled to off side.
- ③Fuse is cut.
- ④Protect device starts, at the same time running director lights.
- ⑤Timer’s setting time is over, at the time running director lights.

1.8 Heating or cooling is inefficient.

- ①Filter is block by duct or rubbish.
- ②The place of air deflector is unfit.
- ③Fan mode is “slight” or running mode is “fan”.
- ④Setting temperature is unfit.
- ⑤ Simultaneously choose the heating and cooling mode, at the time the “no priority” or “waiting” director light of panel lights.

2. Air Conditioner Protection in Common

2.1 Compressor protection.

When power is on, or machine stops then restarts right away, outdoor unit will run in 3 minutes to protect the compressor from too frequent starts and stops.

2.2 When the protection device functions, running stops. Refer to the following:

- ①forced to start but not possess the start article, and display light lights.
- ②When cooling running, inlet and outlet of outdoor unit are blocked, outside strong air blows into outdoor unit’s outlet.
- ③When heating running, dust adheres to air filter to block inlet or outlet of outdoor unit.

Note: when protecting, please cut manual power switch. After checking the reason and solving it, restart.

2.3 Power fails.

- ①If power supply fails while machine is running normally, system will record this.
- ②When the machine is powered on again, the running light of wire controller would flash to inform user about this.
- ③Press the on/off key of wire controller to confirm this before restart the system.

Note: When running, if system takes place mistaken operation or lighter, please pull down the power supply switch to cut it off. Before restarting machines, please press the on/off key again as above.

3. Malfunction Code and Troubleshooting

If there is phenomenon as follows, please stop air conditioner running and cut power supply and refer to the following. However, if the problem insists, please contact the customer service center of Midea commercial air conditioner company, and offer machine's model and detailed malfunction.

--	--	--

18-20HP

Code	Malfunction or protection	remark
E0	Outdoor unit communication error	Display in auxiliary unit only
E1	Phase squence error	
E2	Communication error between indoor unit and main unit	
E3	Reserve	
E4	Outdoor temp sensor error	
E5	Reserve	
E6	Reserve	
E7	Reserve	
E8	Outdoor unit address error	
E9	Voltage error	
H0	Communication error between DSP and 780034	
H1	Communication error between 0537 and 780034	
H2	Outdoor unit qty. decrease error	Display in main unit only
H3	Outdoor unit qty. increase error	Display in main unit only
H4	Three times of P6 protect in 30 minutes	
H5	Three times of P2 protect in 30 minutes	Must be re-powered on for the recovery
H6	Three times of P4 protect in 100 minutes	Must be re-powered on for the recovery
H7	Qty of indoor unit decreases	
H8	$P_c \leq 0.3\text{MPa}$	
P0	Inverter top temp. protection	
P1	High-pressure protection	
P2	Low-pressure protection	
P3	Compressor overcurrent protection	
P4	Compressor discharge temp. protection	
P5	Outdoor condenser high temp. protection	
P6	Inverter module protection	
P7	Current protection, No.1 fixed compressor	
P8	Current protection, No.2 fixed compressor	
P9	Current protection, No.3 fixed compressor	
L0	Module error	Display during spot inspecting
L1	DC busbar low voltage protection	Display during spot inspecting
L2	DC busbar high voltage protection	Display during

		spot inspecting
L3	Reserve	Display during spot inspecting
L4	MCE error/ synchronize/ closed loop	Display during spot inspecting
L5	Zero velocity protection	Display during spot inspecting
L6	Reserve	Display during spot inspecting
L7	Phase squence error protection	Display during spot inspecting
L8	The speed difference between the previous time and the following time > 15Hz protection	Display during spot inspecting
L9	The speed difference between the setting speed and actual speed>15Hz protection	Display during spot inspecting

For 30HP

Code	Malfunction or protection	remark
E0	Outdoor unit communication error	Display in auxiliary unit only
E1	Phase squence error	
E2	Communication error between indoor unit and main unit	
E3	Reserve	
E4	Outdoor temp sensor error	
E5	Reserve	
E6	Reserve	
E7	Reserve	
E8	Outdoor unit address error	
E9	Voltage error	
H0	Communication error between DSP and 780034	
H1	Communication error between 0537 and 780034	
H2	Outdoor unit qty. decrease error	Display in main unit only
H3	Outdoor unit qty. increase error	Display in main unit only
H4	Three times of P6 protect in 30 minutes	
H5	Three times of P2 protect in 30 minutes	Must be re-powered on for the recovery
H6	Three times of P4 protect in 100 minutes	Must be re-powered on for the recovery
H7	Qty of indoor unit decreases	
H8	$P_c \leq 0.3\text{MPa}$	
H9	P9 protection occur 3 times within 30 minutes	
P0	Inverter top temp. protection	
P1	High-pressure protection	
P2	Low-pressure protection	

P3	Compressor overcurrent protection	
P4	Compressor discharge temp. protection	
P5	Outdoor condenser high temp. protection	
P6	Inverter module protection	
P9	Fan protection	
F1	Current protection, No.1 fixed compressor	
F2	Current protection, No.2 fixed compressor	
F3	Current protection, No.3 fixed compressor	
F4	Current protection, No.4 fixed compressor	
F5	Current protection, No.5 fixed compressor	
L0	Module error	Display during spot inspecting
L1	DC busbar low voltage protection	Display during spot inspecting
L2	DC busbar high voltage protection	Display during spot inspecting
L3	Reserve	Display during spot inspecting
L4	MCE error/ synchronize/ closed loop	Display during spot inspecting
L5	Zero velocity protection	Display during spot inspecting
L6	Reserve	Display during spot inspecting
L7	Phase squence error protection	Display during spot inspecting
L8	The speed difference between the previous time and the following time > 15Hz protection	Display during spot inspecting
L9	The speed difference between the setting speed and actual speed>15Hz protection	Display during spot inspecting

3.2 "E1": Phase sequence malfunction

Outdoor Unit Display **E1**

Error Explanation A, B, C terminal of three-phase power supply correspond with U,V,W of the compressor. The compressor could work normally only when they make good matches.

Supposed Causes
1. Phase sequence of the electricity supply does not match.
2. In most circumstance, the reason is lack of power phase.

Troubleshooting

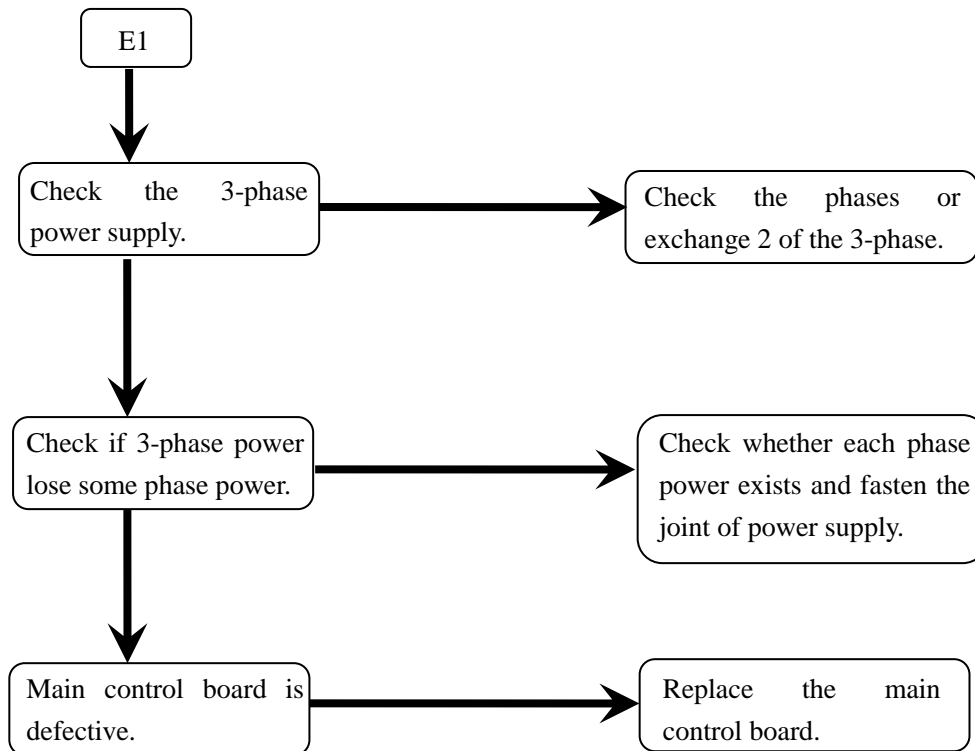

3.3 "E2": Communication failure between master ODU and IDU

Outdoor Unit Display	E2 (Master unit displays only)
Error Explanation	<ol style="list-style-type: none"> 1. Timer LED of indoor unit flashes quickly. 2. The number of indoor unit that displayed on outdoor unit changes . 3. Some of the indoor unit do not work, etc.
Supposed Causes	<ol style="list-style-type: none"> 1. IDU have the same address or the net address is set incorrectly. 2. The signal lines do not work well. 3. PQE bus is conducted somewhere.
Troubleshooting	<ol style="list-style-type: none"> 4.

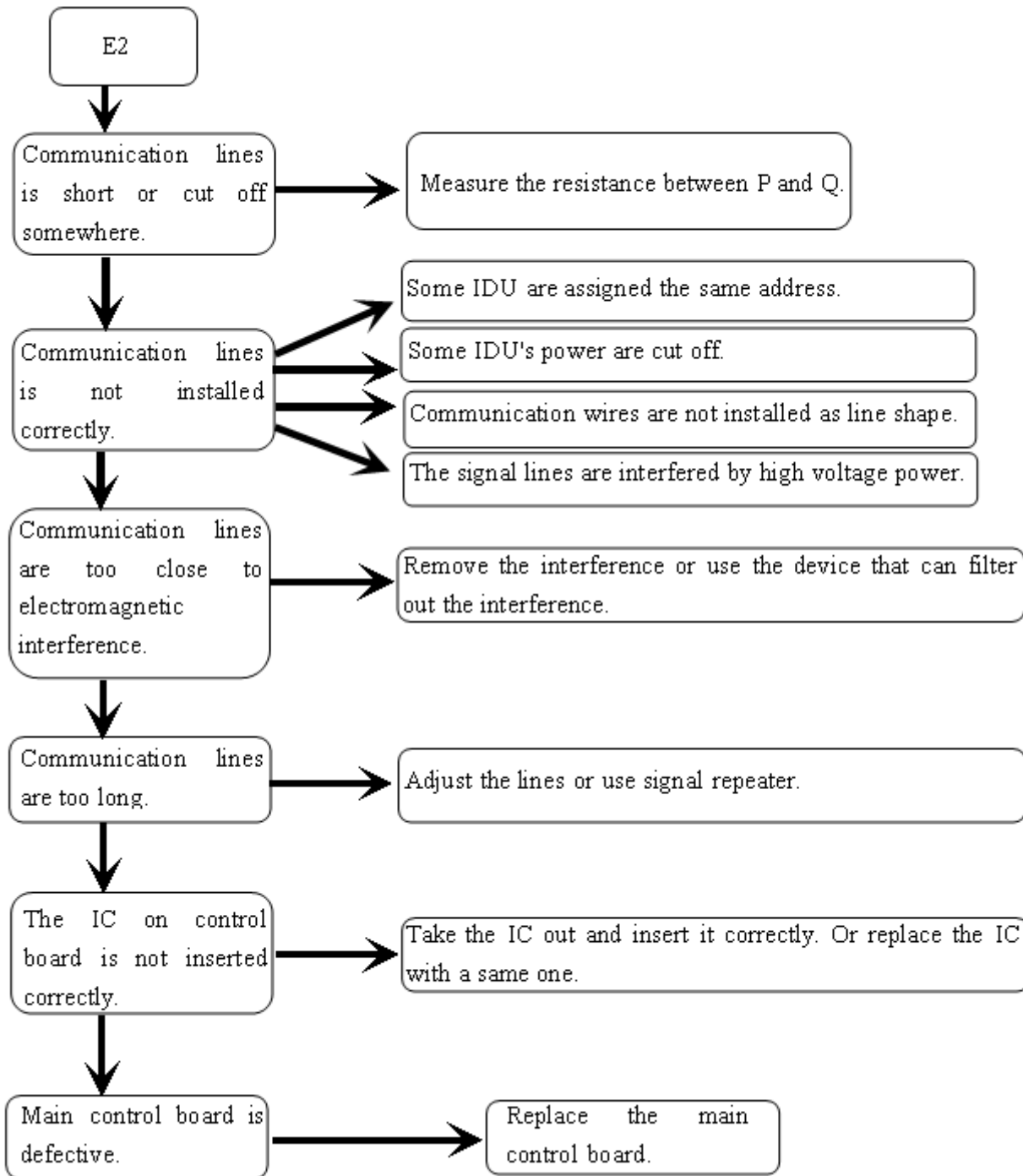

Remarks:

1. Press indoor unit's receiver button for 5 seconds, the indoor unit's communication address code is displayed; press it for 10 seconds, power code is displayed. Check every unit's address code. Codes are as

follows:

Director light	Running	Timer	Fan/defend cold fan	Warning
Code	8	4	2	1

Address	0	1	2	3	4	5	6	7	8	9
Capacity ($\times 100W$)	22	28	36	45	56	71	80	90	112	140
HP	0.8	1.0	1.2	1.6	2.0	2.5	3.0	3.2	4.0	5.0

- If the signal is weak, a 120Ω resistor should be installed at the end of P and Q line of indoor units, and another 120Ω resistor should be installed at the end of P and Q of outdoor units. Installation refers to the picture following:

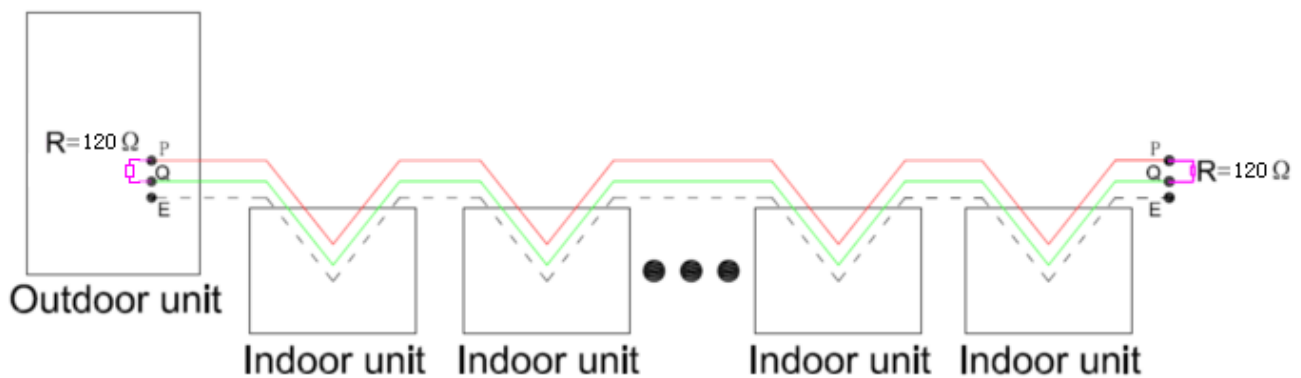

3.4 "E4": Ambient temp. sensor malfunction

Outdoor Unit Display **E4**

Error ODU displays E4.

Explanation

- Supposed Causes**
1. The sensor terminal is loose.
 2. The sensor circuit is short or open.
 3. The main control board's clamp diodes are short or open.

Troubleshooting

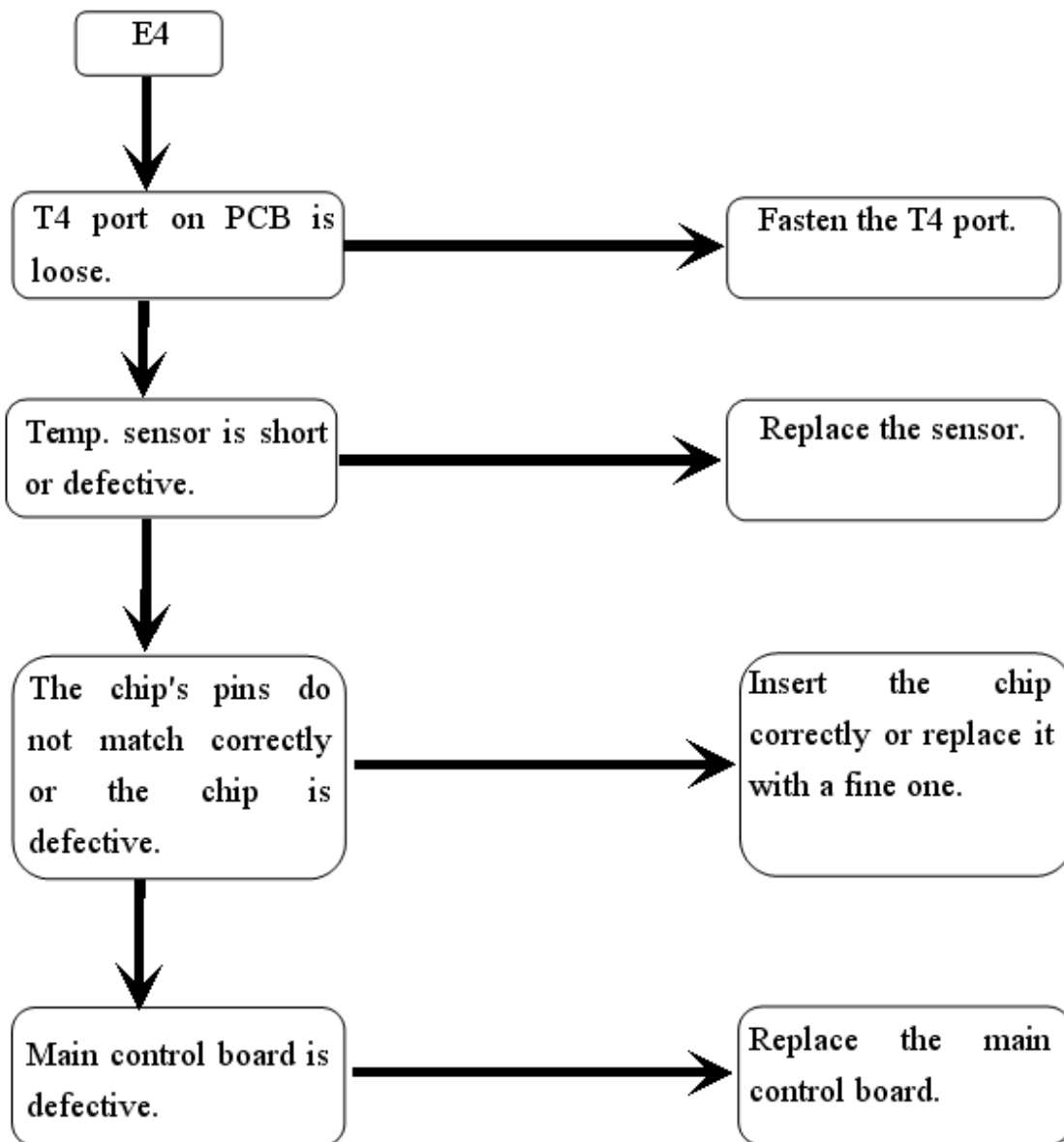

3.4 "E8": Outdoor unit address error

Outdoor Unit Display

E8

Error Explanation
ODU displays E8.

Supposed Causes
 1. Malfunction of chip or the foot of chip or the mistaken installation of the chip .
 2. PCB malfunction.

Troubleshooting

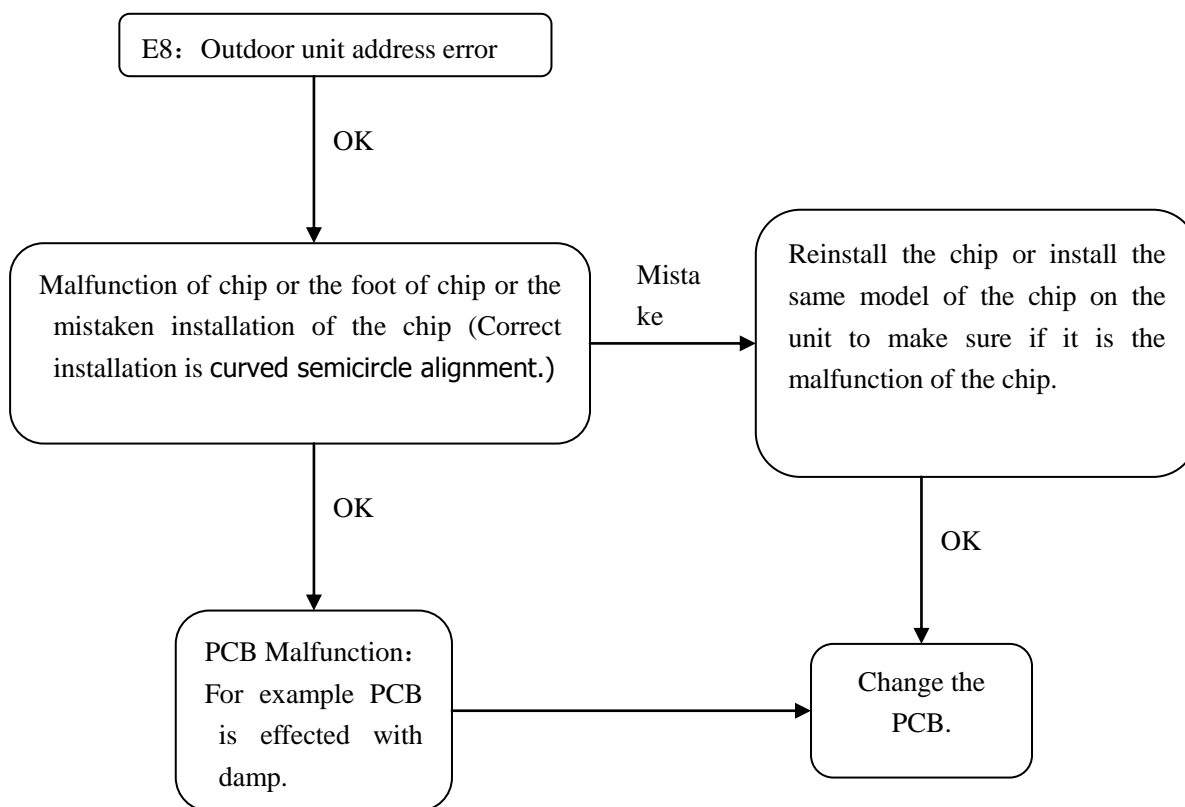

3.6 "E9": Voltage malfunction

Outdoor Unit Display **E9**

Error Explanation ODU displays E9. All the ODU standby.

Supposed Causes 1.The voltage of power supply is too high or too low. 2.The voltage of power supply fluctuates. 3.The IC is loose or main board fails.

Troubleshooting

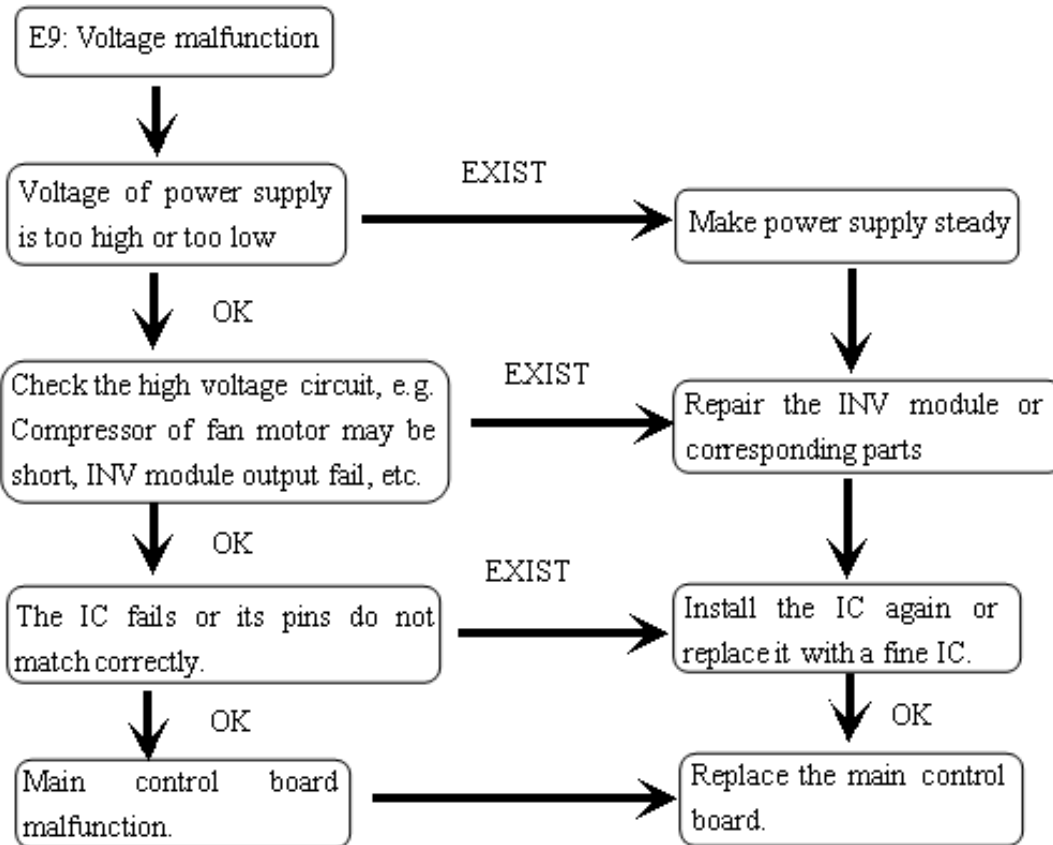

3.7 "H0": Communication malfunction between DSP and 780034

Outdoor Unit
Display

H0

Error Explanation DSP IC is used for providing running parameter to compressor. IC780034 send the system's parameter such as T3, T4, ODU power need, exhaust temp. etc. From which DSP IC calculates the compressor's frequency.

Supposed Causes

1. The power supply of DSP IC fails to work normally.
2. Defect of either the DSP or the 780034.
3. Disconnection of the IC 780034 pins.
4. Defect of main control board.
5. Environmental interference.

Troubleshooting Normally the only way to deal with is to replace the main control board.

3.8 H1: Communication malfunction between IC 0537 and IC 780034

Outdoor Unit
Display

H1

Error Explanation For V4 and V3 series, error happens between IC 9177 and IC 780034.
For V4+ series, error happens between IC 0537 and IC 780034.

Supposed Causes

1. IC 9177 or IC 0537 or IC 780034 is defective.
2. Disconnection of the pins of IC 780034.
3. Environment interference.

Troubleshooting Normally the only way to deal with is to replace the main control board.

3.10 "H7": Outdoor unit quantities decreasing malfunction

Outdoor Unit Display **H7**

Error Explanation ODU displays H7. All the ODU standby.

- Supposed Causes**
1. The communication terminal of IDU is loose.
 2. The voltage transformer of IDU is defective.
 3. IDU installation is not standard, which are not unified powered.
 4. The control board of IDU is defective.

Troubleshooting

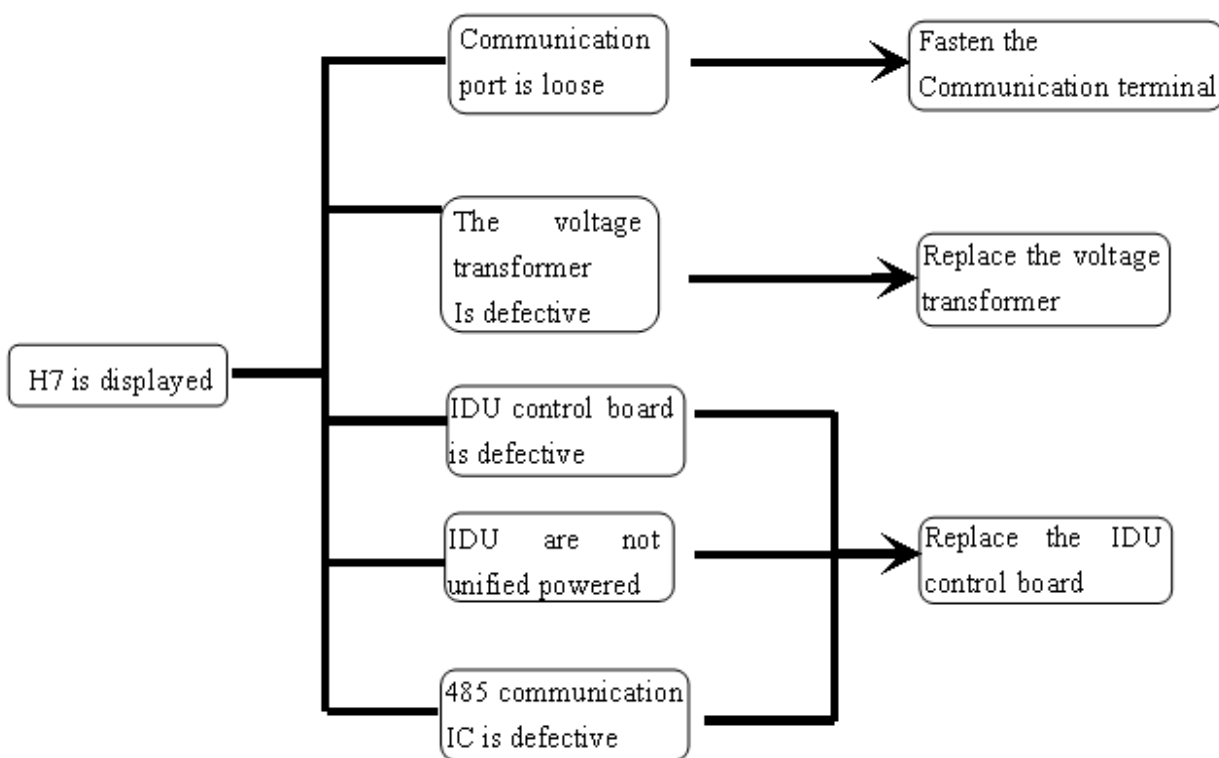

3.11 "P0": The sensor protection on the top of inv. Compressor

Outdoor Unit
Display

P0

Error
Explanation

One ODU displays P0 and changes to protecting standby state.

Supposed
Causes

1. Refrigerant is not enough.
2. Efficiency of outdoor heat exchange is low.
3. Refrigerant does not loops smoothly
4. Control board is defective

Troubleshooting

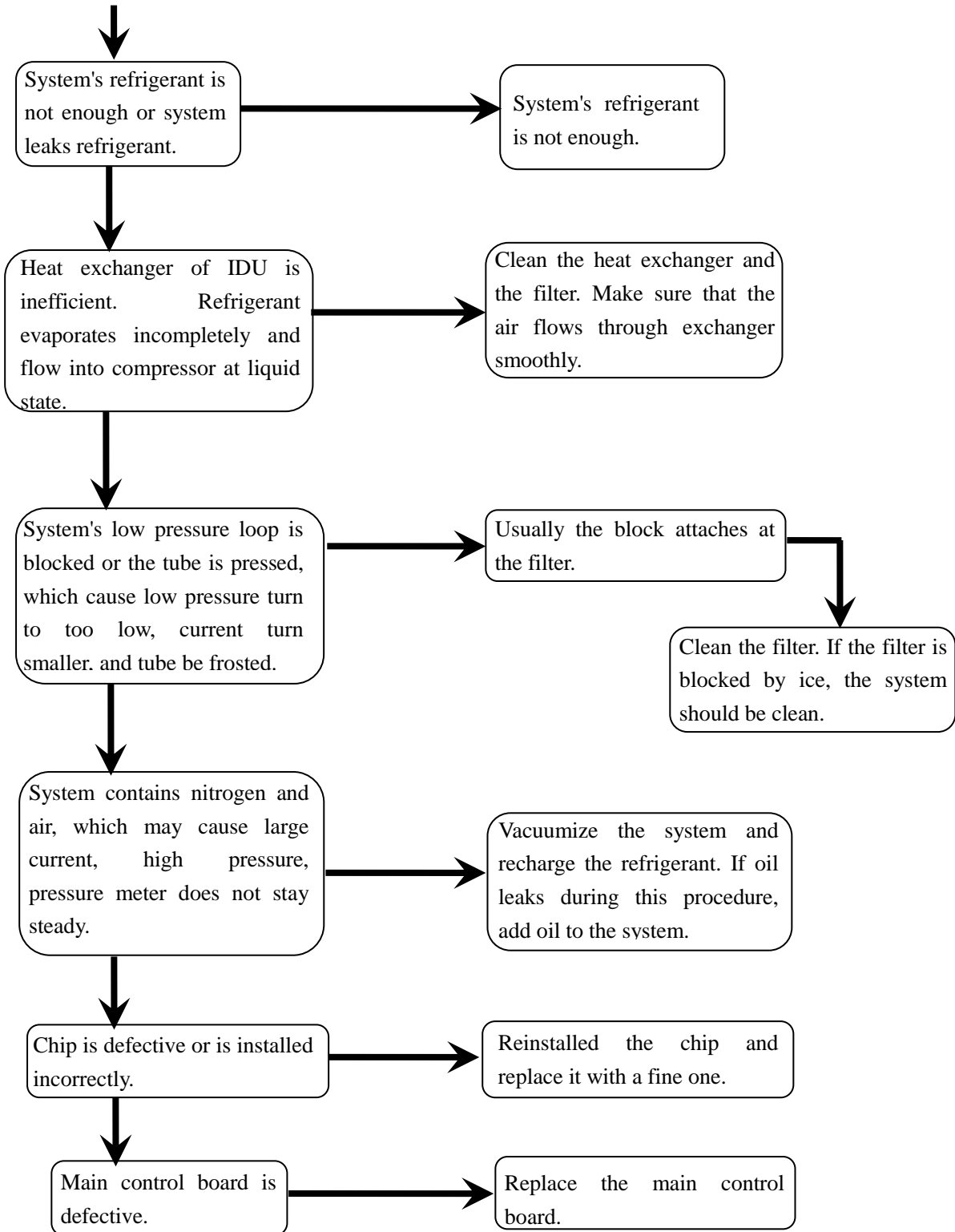

Remarks: When system appear 3 times P0 or P4 protection in 100 minutes, system will auto shut down and display H6 malfunction, which can recover only by restarting the machine. At this time, malfunction should be promptly treated to avoid further damage.

3.12 "P1": High pressure protection

Outdoor Unit
Display **P1**

Error Explanation One ODU displays P1 and changes to protecting standby state.

Supposed Causes

1. Refrigerant is excess.
2. Refrigerant does not loop smoothly.
3. The refrigerant loop contains air.
4. Control board is defective.

Troubleshooting

P1: High pressure protection(R22 refrigerant system protects at 3.3MPa, recovers at 2.4MPa ; R410 refrigerant system protects at 4.4MPa, recovers at 3.2MPa).

Heat exchanging of ODU is not efficient. This may be caused by dirty heat exchanger, abnormal ODU fan running, air flow keeping off to the heat exchanger, ODU are too near to each other.

Check the system and fixed up the error.

System's liquid refrigerant loop is blocked. This may be caused by blocked valve, pressed tube, closed blocked valve.

Check the system and get rid of the block, and make the loop smooth.

Refrigerant is excess. In this circumstance, the refrigerant's low pressure is high, so is the high pressure side, while the discharge temperature is low.

Discharge part of the refrigerant. Add some oil to the system if it leaks during the discharge.

System contains air or nitrogen. In this circumstance, the high pressure is high, the current is large, the discharge temperature is high, compressor makes noise, the pressure meter do not display steady.

Discharge all the refrigerant. Then vacuumize the system and refill the refrigerant. Add oil to the system if it leaks.

Chip is defective or incorrectly installed. Or the high pressure sensor is disconnected.

Reinstall the chip or replace it with a fine one.

Control board is defective.

Replace the main control board.

3.13 "P2": Low pressure protection

Outdoor Unit
Display **P2**

Error Explanation One ODU displays P2 and changes to protecting standby state.

Supposed Causes

1. Refrigerant is not enough.
2. Refrigerant does not loop smoothly.
3. Efficiency of indoor heat exchange is low.
4. Control board is not defective.

Troubleshooting

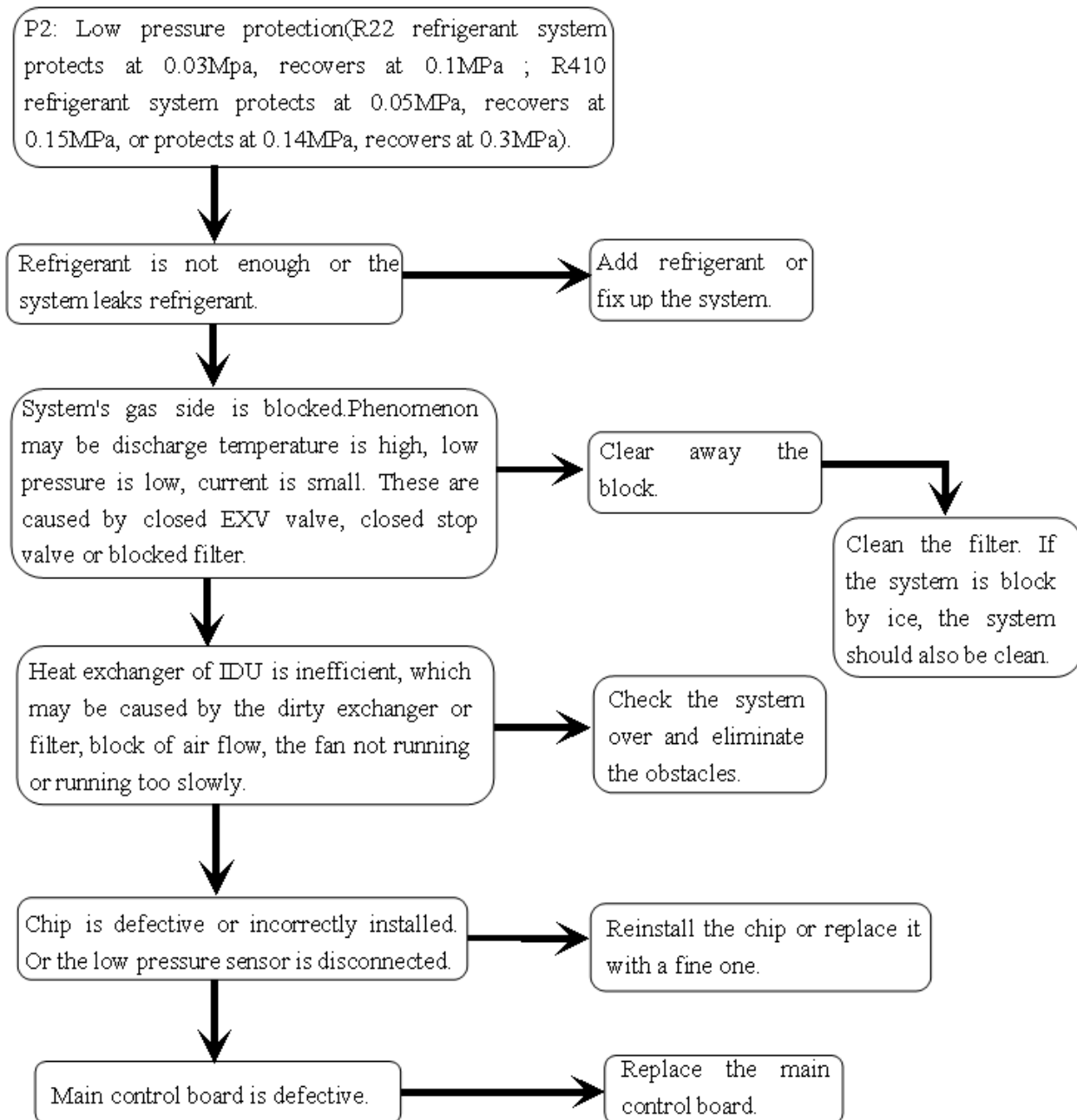

Remarks: When system appear 3 times P2 protection in 30 minutes, system will auto shut down and display H5 malfunction, which can recover only by restarting the machine . Malfunction should be promptly treated to avoid further damage.

3.14 "P3""F1""F2""F3""F4""F5": **Inv. compressor over current protection**

Outdoor Unit Display **P3,F1,F2,F3,F4 ,F5**

Error Explanation ODU displays P3,F1,F2,F3,F4,F5.

- Supposed Causes
1. Load on ODU is excess.
 2. Outdoor heat exchanging is not efficient.
 3. Refrigerant is excess.
 4. Compressor or its circuit is defective.
 5. Control board is defective.

Troubleshooting

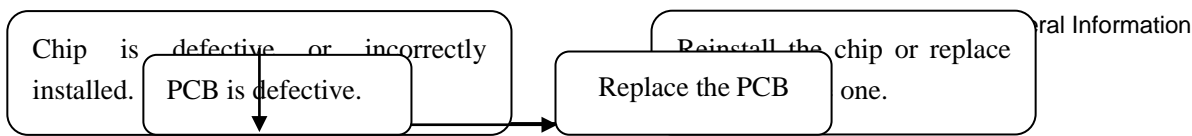

P3、F1、F2、F3、F4、F5: Inverter compressor over current protection (When current of BP compressor is higher than 11A, it will be protected if the current of one fixed compressor is higher than 16A.)

Check one by one to confirm the malfunction.

3.15 "P4": Discharge temp. sensor protection

Outdoor Unit Display **P4**

Error One ODU displays P4 and changes to protecting standby state.

Explanation

- Supposed Causes**
1. Refrigerant is not enough.
 2. Refrigerant does not loop smoothly.
 3. Compressor needs more oil.
 4. Control board is defective

Troubleshooting

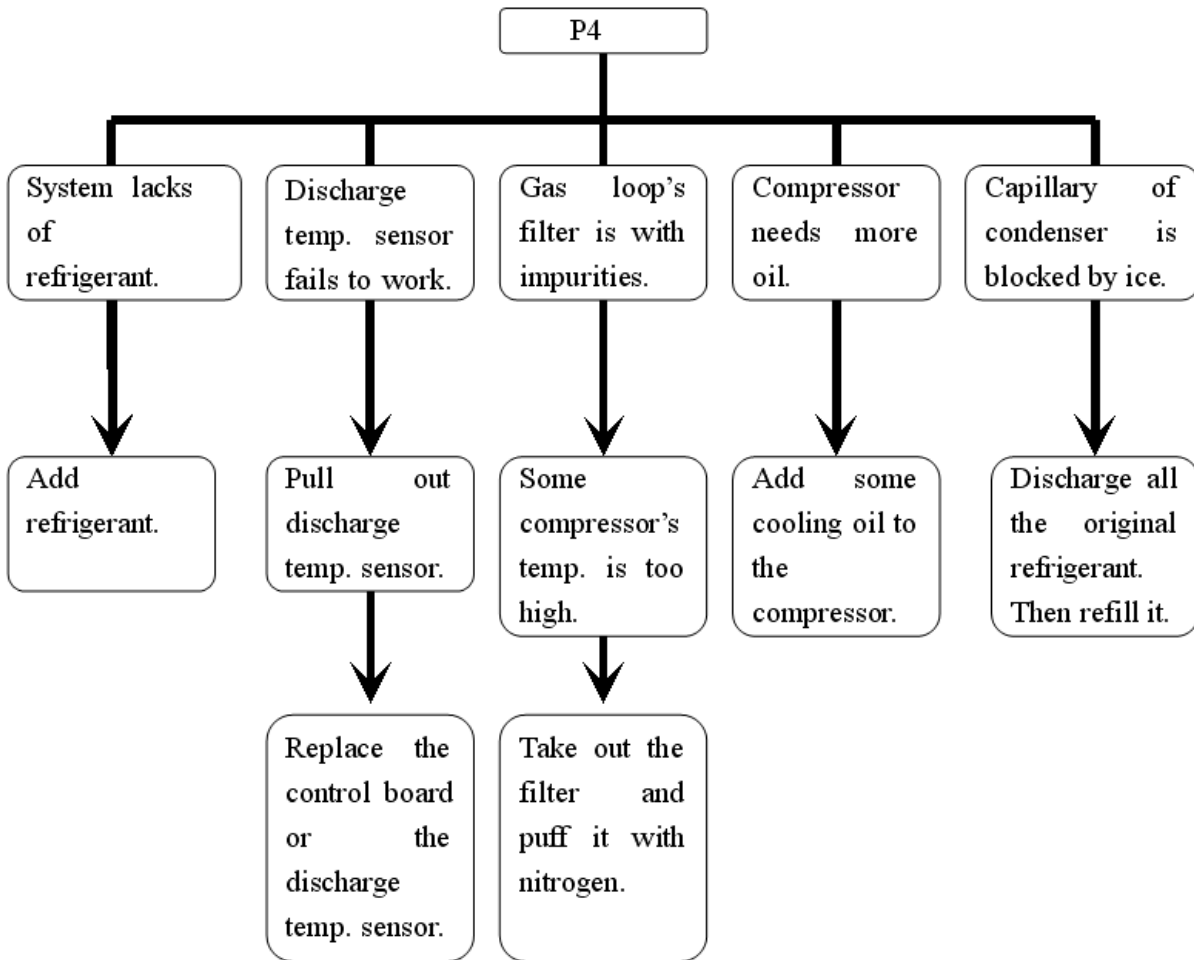

3.16 "P5": Pipe temp. sensor protection

Outdoor Unit
Display

P5

Error Explanation **One ODU displays P4 and changes to protecting standby state.**

Supposed Causes

1. System's load is excess.
2. Heat exchanging is not efficient.
3. Liquid refrigerant is blocked.
4. Refrigerant is mixed with impurities.

Troubleshooting

3.17 "P6": Module protection

Outdoor Unit Display **P6**

Error ODU displays P6.
Explanation

- Supposed Causes**
1. DC generatrix is not lined correctly.
 2. DC generatrix low or high voltage protection.
 3. MCE malfunction.
 4. Compressor's frequency changes incorrectly.

Troubleshooting

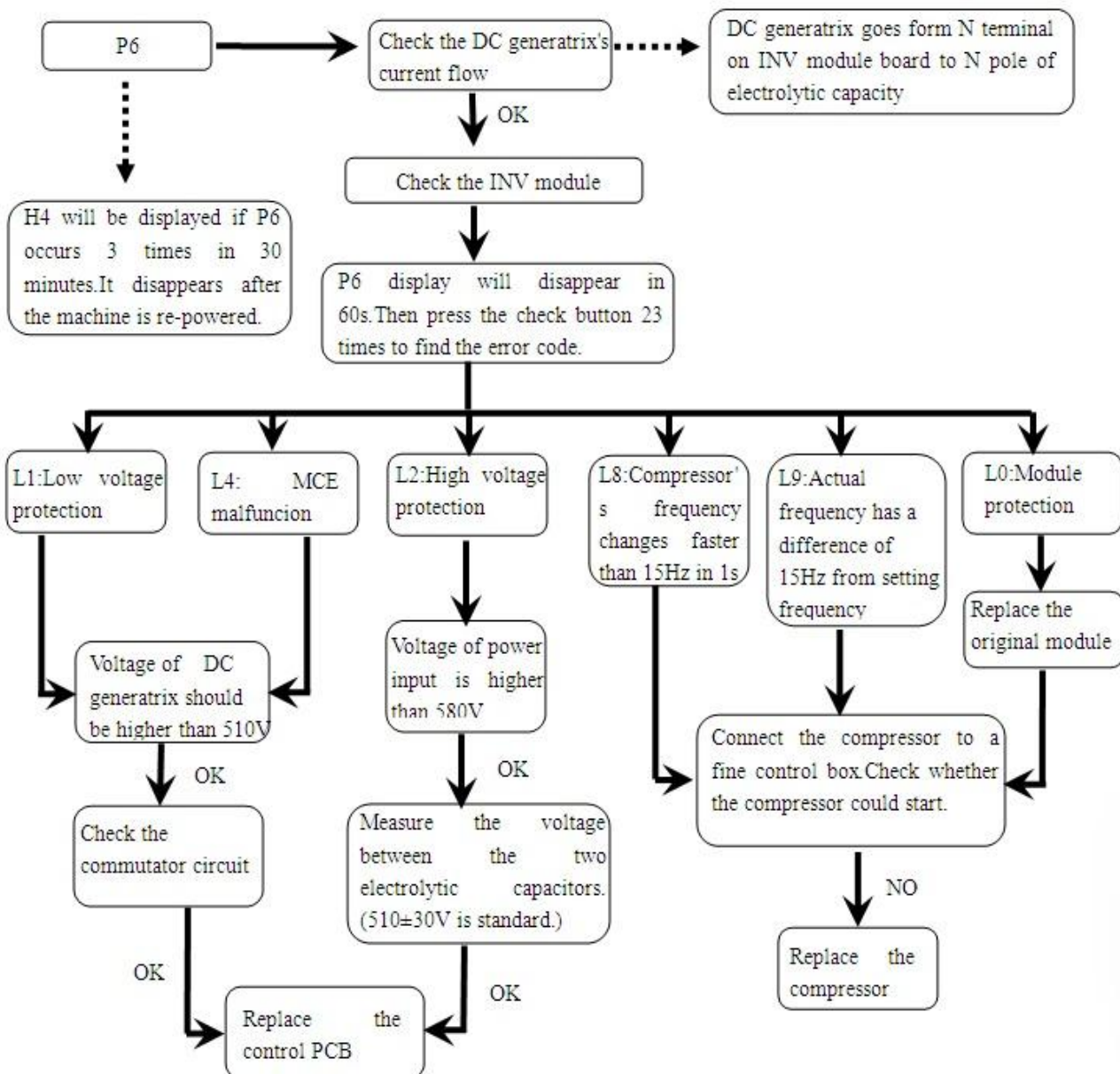

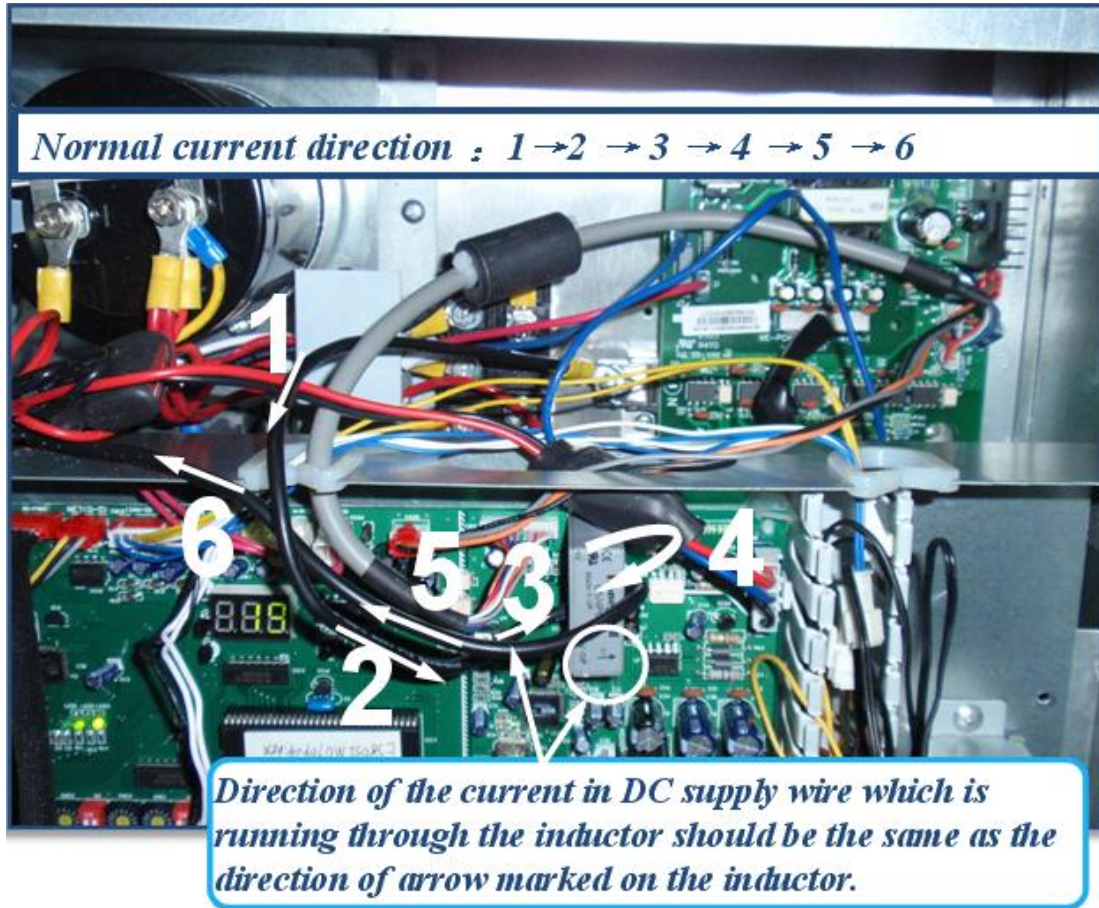

1.2 Voltage check of DC generatrix

1.2.1 Check the voltage of DC generatrix, which is normal between 510V and 580V. If less, go to next step.

1.2.2 Check the rectification circuit. Find out any loose in the circuit. Moreover check the filter board, rectifier stacks. Mind DC and AC switch on the meter while doing this.

1.2.3 If none of the above works, replace the main control board.

2 Voltage check of module

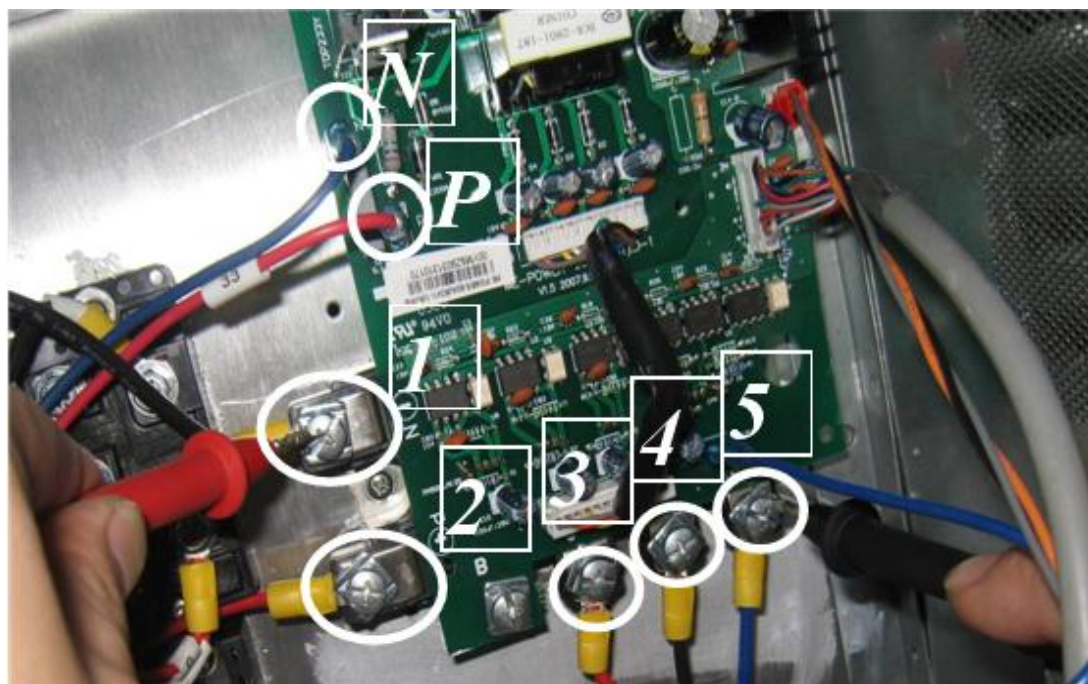

2.1 The voltage between N and P should be 1.41 times to local power supply.

2.2 The voltage between 1 and 2 should range from 510V to 580V

2.3 The resistance between 1,2,3,4,5 should be infinite. If any of them is about 0, which means the module has already been broken down, we need to replace the module.

3 Compressor's characteristics

3.1 Measure the resistance among the compressor's U,V,W respectively. The resistance should range from 0.9 to 5 Ohms and be the same.



Fig. A



Fig. B

3.2 Measure the resistance between the compressor's U,V,W and GND respectively. The resistance should be more or less mega-Ohms.



Fig. C



Fig. D

3.3 Measure the current of the compressor's U,V,W terminal respectively, which should be more or less the same, by e.g. current flow table clamp. They should be 4A at the frequency of 35 Hertz.

4 P6 appears after the compressor turns on with difficulties

4.1 Check the module according to step 3 first.

4.2 If the module works, make the machine standby for 4 hours with power supply, which can help heating the refrigerant and oil adequately.

4.3 Start the fixed frequency compressor only for 3S to 5S. The great startup pressure could wash the impurity away in the tube.

4.4 If the compressor's frequency climb to 37 Hertz or above in 2S after turning on, then there's something wrong with the compressor. Check the compressor.

4.5 If the compressor's current is normal, the malfunction appears on the control board. Please replace it.

5 The machine is powered on and P6 appears at once

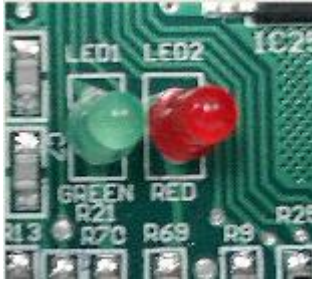

In normal situation:

LED 1: Flash in 1Hz (slowly flash) when standby

LED 1: On when running

LED 2: Off

Phenomenon A

LED 2 red ON

LED 1 green Flashes 8 times and stops for 1S, then repeat.

Error: Inverter module failure

Phenomenon B

LED 2 red ON

LED 1 green Flashes 9 times and stops for 1S, then repeat.

Error: Low voltage protection

Here are 3 circumstances:

- a) The voltage between the two electrolytic capacitors is less than 450V. The AC contactor should be picked up. If not, there's something wrong with the main control board or the PTC resistors, which need to be replaced correspondingly.
- b) Somewhere is loose in the circuit.
- c) The voltage between P and N of CN12 on the main control board should range from 450V to 570V. If the voltage between N terminal and middle terminal of CN12 is 15V while error displays, it means that the main control board fails. Please replace the main control board.

Phenomenon C

LED 2 red ON

LED1 Green Flashes 10 times and stops for 1S, then repeat.

Error: High voltage protection

Here are 2 circumstances:

6. Three-phase power supply 's voltage is more than 440V
7. Main control board fails. Please replace it.

3.18 "P7": Fixed 1 current protection

Outdoor Unit
Display **P7**

Error ODU displays P7.
Explanation

Supposed Causes

1. Load on ODU is excess.
2. Outdoor heat exchanging is not efficient.
3. Refrigerant is excess.
4. Compressor or its circuit is defective.
5. Control board is defective.

Troubleshooting

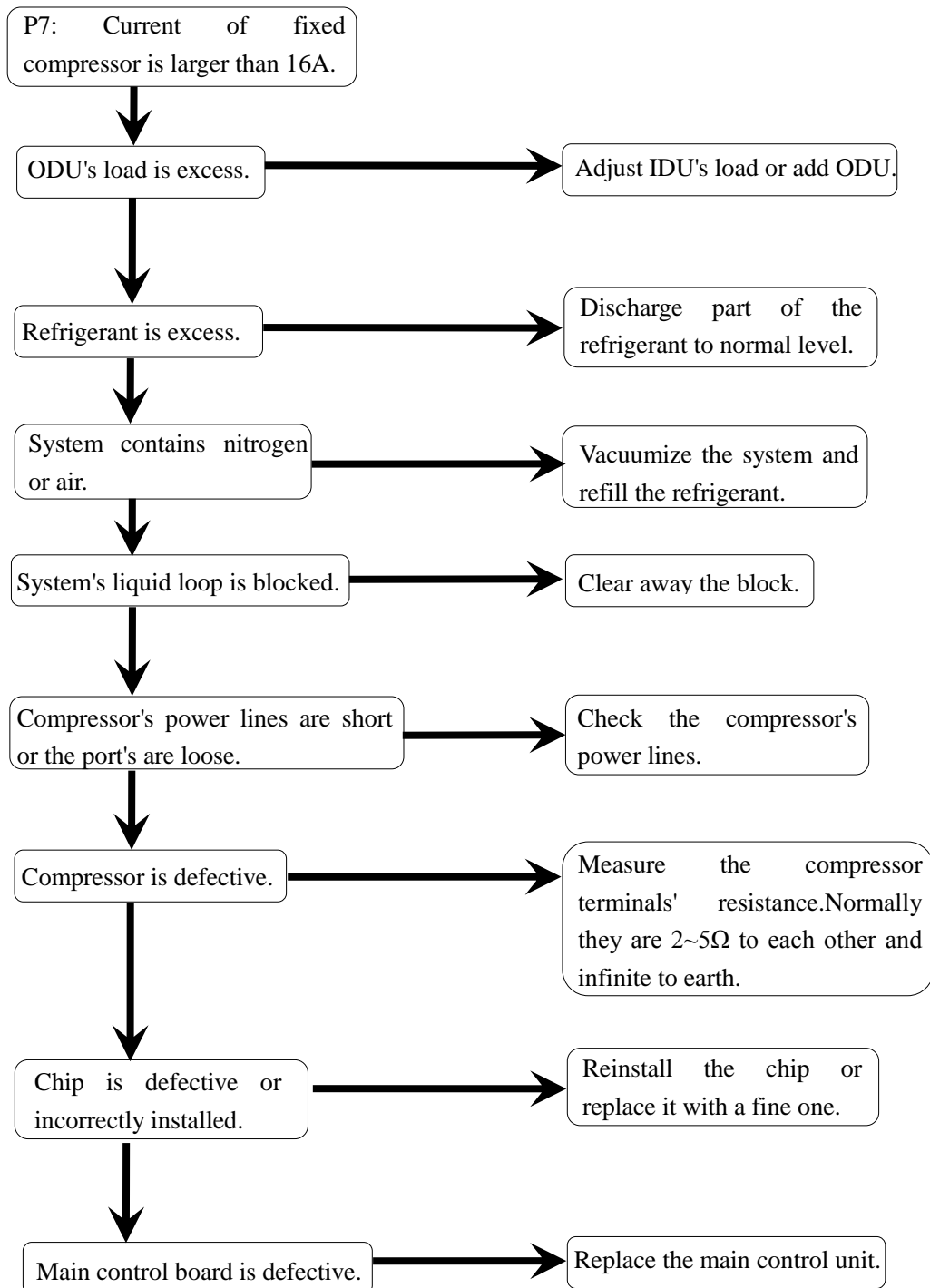

3.19 "P8": Fixed 2 current protection

Outdoor Unit
Display

P8

Error ODU displays P8.
Explanation

Supposed 1. Load on ODU is excess.
Causes 2. Outdoor heat exchanging is not efficient.
3. Refrigerant is excess.
4. Compressor or its circuit is defective.
5. Control board is defective.

Troubleshooting

3.20 "P9": Fan module protection

Outdoor Unit Display **P9(V4+)**

Error Explanation ODU displays P9. Only V4+ series system would display this code.

- Supposed Causes**
1. Control box is too hot.
 2. Fan is blocked or is defective or is not powered correctly.
 3. Signal line is loose.
 4. Fan module is defective.

Troubleshooting

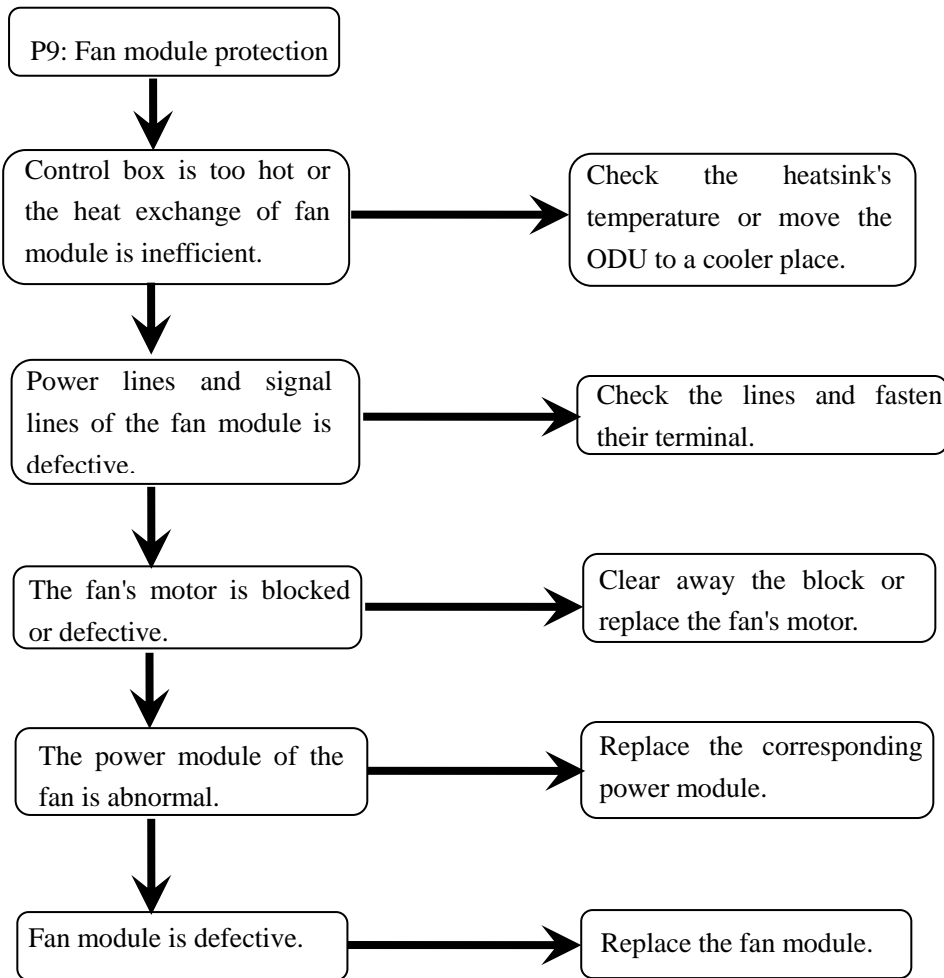

Remarks: If P9 occurs 3 times in 30 minutes, system will auto shut down and display H9 malfunction, which can recover only by restarting the machine. At this time, malfunction should be promptly treated to avoid further damage.

Part 6

Electric and Control System

1. Electric System.....	151
1.1 Wiring Diagrams and Field Wiring	1518
1.2 Description of Main Control Board of Outdoor unit	151
1.3 SW1 Query Instruction	Ошибка! Закладка не определена.
1.4 Description of Main Control Board of Indoor unit	157
1.5 Electric Wiring Installations.....	160
2. Control System.....	164
2.1 Control System Introduction	164
2.2 Wireless Remote Controller.....	171
2.3 Wired Controller	175
2.4 Central Control Monitor	183
2.5 Network Control System	209
2.6 Other Accessory	215

1. Electric System

1.1 Wiring Diagrams and Field Wiring

Wiring diagrams and field wiring please refer to “6. Wiring Diagrams and field wiring” of “Part 2 Specification & Performance”

1.2 Description of Main Control Board of Outdoor unit

18-20HP

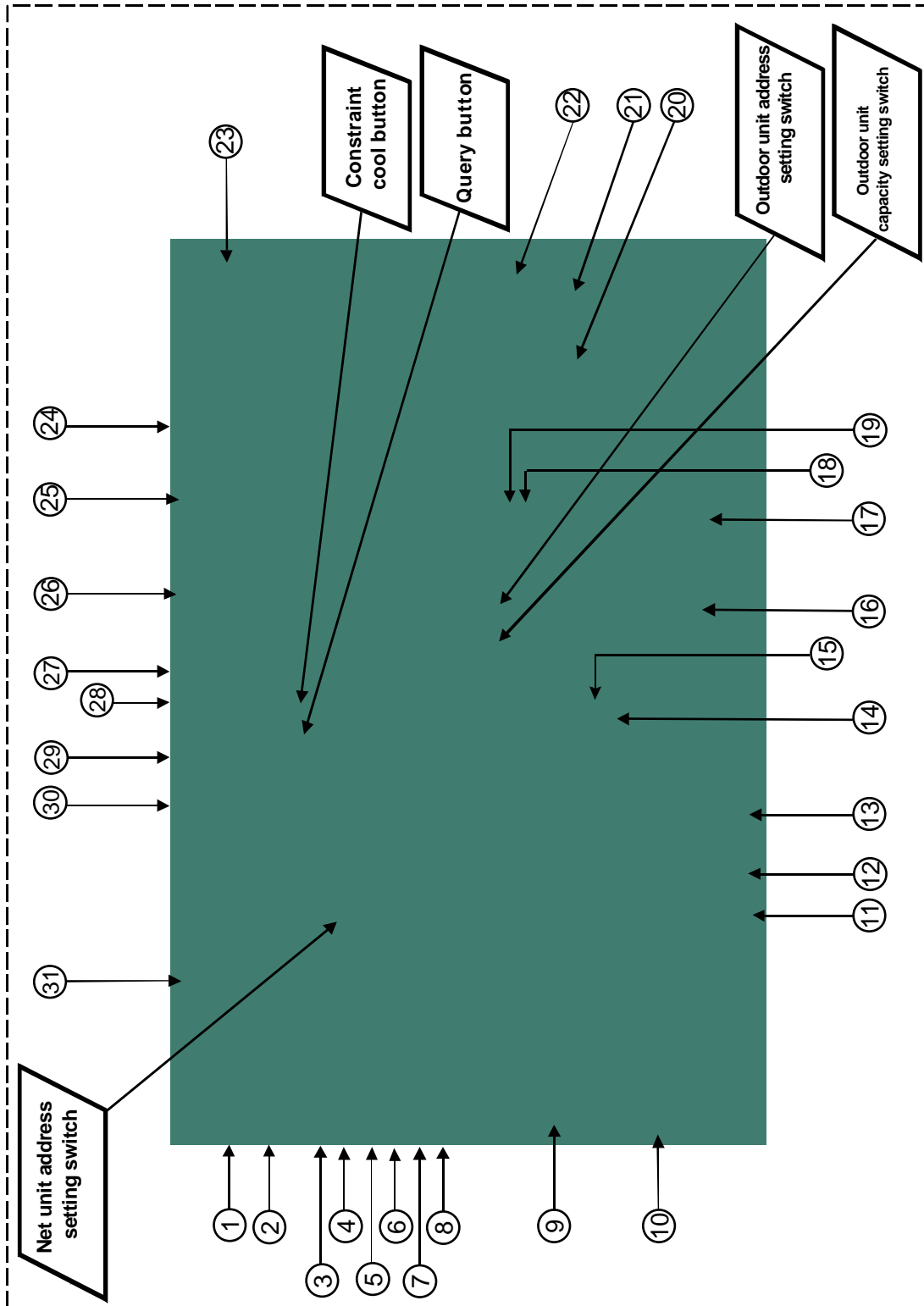

30HP

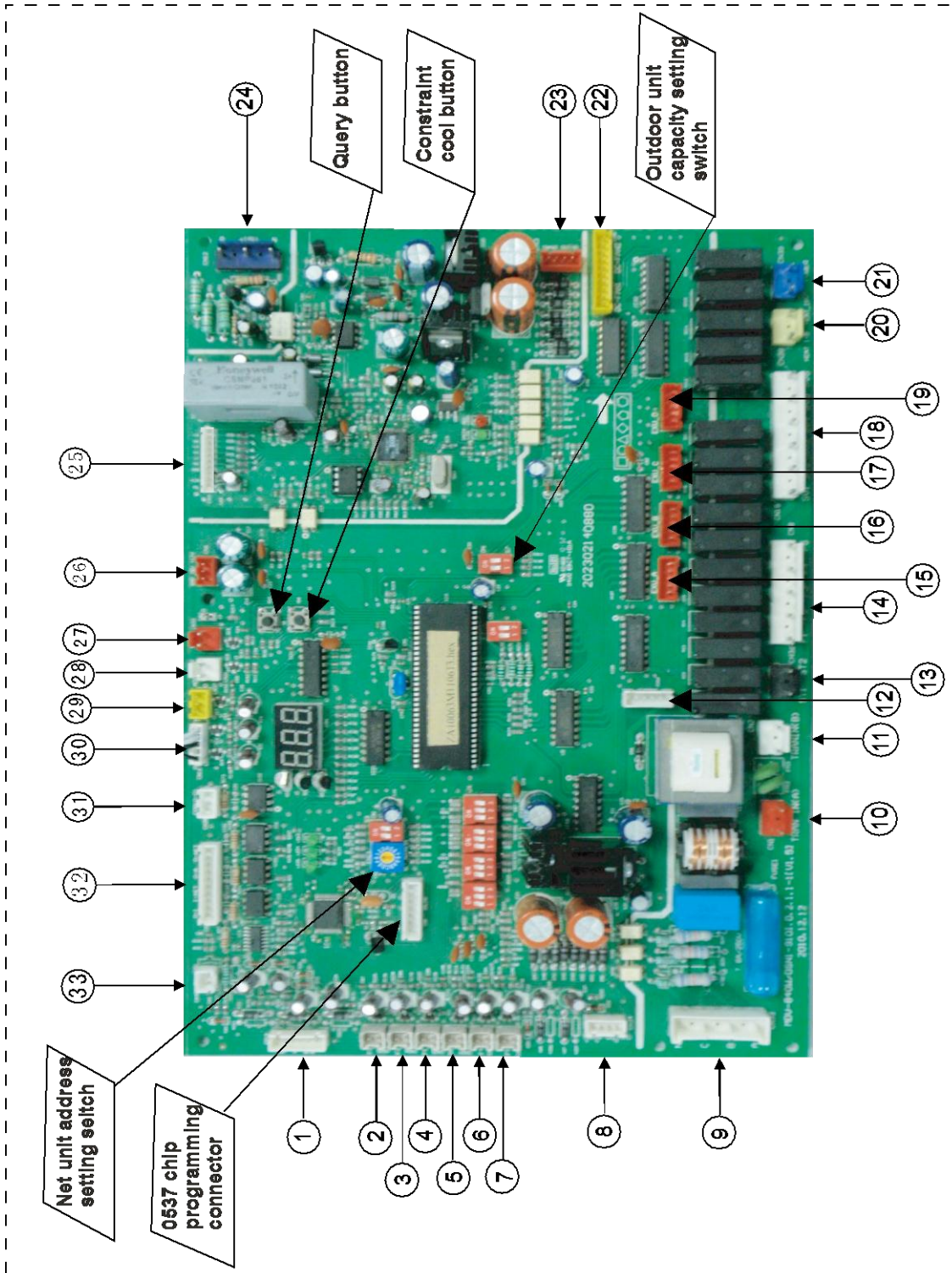

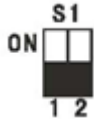

Dial codes definition

S1 definition

	
Starting time is set about 3 minutes	Starting time is set about 12 minutes(Default)

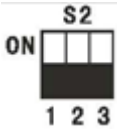
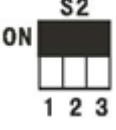
S2 definition

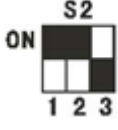

			
Night time selection is 6h/10h(default)	Night time selection is 8h/10h	Night time selection is 6h/12h	Night time selection is 8h/8h

S3 definition is reserved

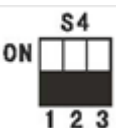
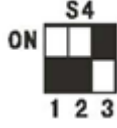

S4 definition

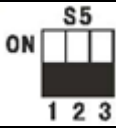
	
Static pressure mode is 0 MPa(default)	Static pressure mode is high pressure

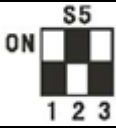
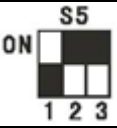
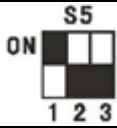
S5 definition

				
Heating prior(default)	Cooling prior	Starting time prior	Only respond to heating mode	Only respond to the cooling mode

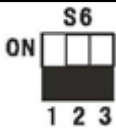
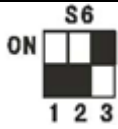
S6 definition – non-grouped keys

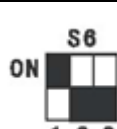
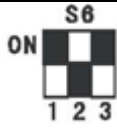
				
Night noise control mode and automatically assign address	Night noise control mode and manually assign address	Clear all the auto assigned address	Night noise control mode unused and automatically assign address	Night noise control mode unused and automatically assign address

S7 definition is reserved

The below is for 30HP.



ENC1: 0 indicates the master unit, 1-3 indicate slave unit.

ENC2: 0, 1, 2, 3, 4 individually correspond 8HP, 10HP, 12HP, 14HP, 16HP

ENC3: network address setting code

18-20HP

No.	Content	No.	Content
1	Curr. Detecting transformer, inverter compressor	17	Load output
2	Curr. Detecting transformer, No.1-3 fixed compressor	18	Low speed of left fan
3	Discharge temp detecting port, No.3 fixed compressor	19	High speed of left fan
4	Discharge temp detecting port, No.2 fixed compressor	20	Electric expansion valve A driving port
5	Discharge temp detecting port, No.1 fixed compressor	21	Electric expansion valve B driving port
6	Discharge temp detecting port, inverter compressor	22	Power output of No.2 transformer
7	Reserved	23	Driving port, inverter module
8	Reserved	24	Curr. Detecting transformer
9	Power output of No.1 transformer	25	Voltage detecting port, inverter module
10	Phase-sequence detecting port	26	Main board power connector
11	C-phase power supply	27	Signal input port, high-pressure detecting switch
12	Power input of No.1 transformer	28	Signal input port, low-pressure detecting switch
13	Power input of No.2 transformer	29	Pressure sensor
14	High speed of right fan	30	Detecting port, outdoor temp and outdoor condenser temp
15	Low speed of right fan	31	Outdoor unit to indoor unit communication and network communication port
16	Load output		

30HP

No.	Content	No.	Content
1	Curr. Detecting transformer, No.1-5 fixed compressor	18	Load output
2	Discharge temp detecting port, No.3 fixed compressor	19	Electric expansion valve D driving port
3	Discharge temp detecting port, No.2 fixed compressor	20	Load output
4	Discharge temp detecting port, No.1 fixed compressor	21	Load output
5	Discharge temp detecting port, inverter compressor	22	DC Fan control port
6	Discharge temp detecting port, No.4 fixed compressor	23	Power output of transformer B
7	Discharge temp detecting port, No.5 fixed compressor	24	Voltage detecting port, inverter module
8	Power output of transformer B	25	Driving port, inverter module
9	3-phase power supply	26	Main board power connect point
10	Power input of transformer A	27	Signal input port, low-pressure detecting switch
11	Power input of transformer B	28	Signal input port, high-pressure detecting switch
12	AC Fan control port	29	Pressure sensor
13	Load output	30	Outdoor temp & Outdoor condenser temp detecting port

14	Load output	31	Reserved
15	Electric expansion valve A driving port	32	Communication port
16	Electric expansion valve B driving port	33	Curr. Detecting transformer, inverter compressor
17	Electric expansion valve C driving port		

SW2 Query Instruction

The 18HP-20HP Type:

No.	Normal Display	Content	Note	No.	Display content	Content	Note
0	0.--	ADDR of outdoor unit	0	14	4.--	Discharge temp, No.1 fixed compressor	Actual Value
1	1.--	Outdoor unit itself capacity	18,20	15	5.--	Discharge temp, No.2 fixed compressor	Actual Value
2	2.--	Qty. of outdoor unit	Effective to main unit	16	6.--	Discharge temp, No.3 fixed compressor	Actual Value
3	3.--	Total capacity of outdoor unit	Capacity requirement	17	7.--	Current, inverter compressor	Actual Value
4	4.--	Cap. REQT. of indoor units	Available for main unit	18	8.--	Current, No.1 fixed compressor	Actual Value
5	5.--	Cap. REQT. of main unit (after correction)	Available for main unit	19	9.--	Current, No.2 fixed compressor	Actual Value
6	6.--	Running mode	0,1,2,3,4	20	0.--	Current, No.3 fixed compressor	Actual Value
7	7.--	Actual running cap. of outdoor unit	Capacity requirement	21	1.--	Discharge pressure	Actual value ×0.1MPa
8	8.--	Fan speed	0,1,2,3,4,5,6	22	2.--	Opening degree, EXV A	Actual value× 8
9	9.--	T2 average temp	Actual value	23	3.--	Opening degree, EXV B	Actual value× 8
10	0.--	T3 pipe temp	Actual value	24	4.--	Qty. of indoor unit	Actual Value
11	1.--	RESERVE	/	25	5.--	The last error or protection code	No protection or error, display 00
12	2.--	T4 ambient temp	Actual value	26	6.--	--	Check end
13	3.--	Discharge temp, inverter compressor	Actual value				

Remark:

1) Normal display:

General Information

Display qty. of indoor units which could communicate with outdoor unit on standby mode. In case of cap. Requirement, display running frequency of the inverter compressor.

2) Running mode:

0--OFF/FAN; 2--COOL; 3--HEAT; 4--Constraint cool

Fan speed: 0--left and right OFF; 1--left off and right low; 2--left off and right high; 3--left low and right off; 4--left high and right off;

5--left low and right low; 6--left high and right high

3) ENC1:Outdoor unit capacity setting switch

ENC2:Outdoor unit address setting switch

ENC3: Network ADDR setting switch

SW1: constraint cool button

SW2: query button

The 30HP Type:

No.	Normal Display	Content	Note	No.	Display content	Content	Note
0	1.--	ADDR of outdoor unit	0	16	7.--	Discharge temp, No.4 fixed compressor	Actual value
1	2.--	Cap. of outdoor unit	28, 30, 32	17	8.--	Discharge temp, No.5 fixed compressor	Actual value
2	3.--	Qty. of outdoor unit	Effective to main unit	18	9.--	Current, inverter compressor	Actual value
3	4.--	Total cap. of outdoor units	Capacity requirement	19	0.--	Current, No.1 fixed compressor	Actual value
4	5.--	Cap. REQT. of indoor units	Effective to main unit	20	1.--	Current, No.2 fixed compressor	Actual value
5	6.--	Cap. REQT. of main unit (after correction)	Effective to main unit	21	2.--	Current, No.3 fixed compressor	Actual value
6	7.--	Running mode	0, 1, 2, 3, 4	22	3.--	Current, No.4 fixed compressor	Actual value
7	8.--	Actual running cap. of outdoor unit	Capacity requirement	23	4.--	Current, No.5 fixed compressor	Actual value
8	9.--	Fan speed	A/B:0, 1, 2, 3, 4, 5, 6, 7, 8, 9	24	5.--	Discharged pressure	Actual value ×0.1MPa
9	0.--	T2/T2B average	Actual value	25	6.--	Opening degree, EXV A、C	Actual value ×8
10	1.--	T3 pipe temp	Actual value	26	7.--	Opening degree, EXV B、D	Actual value ×8
11	2.--	T4 ambient temp	Actual value	27	8.--	The limitation of Indoor unit proformed mode	0, 1, 2, 3, 4
12	3.--	Discharge temp, inverter	Actual value	28	9.--	Qty. of indoor unit	Actual value

		compressor					
13	4.--	Discharge temp, No.1 fixed compressor	Actual value	29	0.--	The last error or protection code	No protection or error display 00
14	5.--	Discharge temp, No.2 fixed compressor	Actual value	30	-----	_ _	Check end
15	6.--	Discharge temp, No.3 fixed compressor	Actual value				

Remarks:

4) Normal display:

Display qty. of indoor units which could communicate with outdoor unit on standby mode. In case of cap. requirement, display running frequency of the inverter compressor.

5) Running mode:

0--OFF/FAN; 2--COOL; 3--HEAT; 4--Constraint cool

6) Fan speed:

0-fan stop;

1~9 speed increase sequentially;

9 is the max. fan speed.

PMV opening: pulse count=displayed value×8

ENC3: Network ADDR setting switch

SW1: constraint cool button

SW2: query button

1.4 Description of Main Control Board of Indoor unit

There are two shapes of main control board that used to all types of indoor unit matching with V4+ outdoor unit.

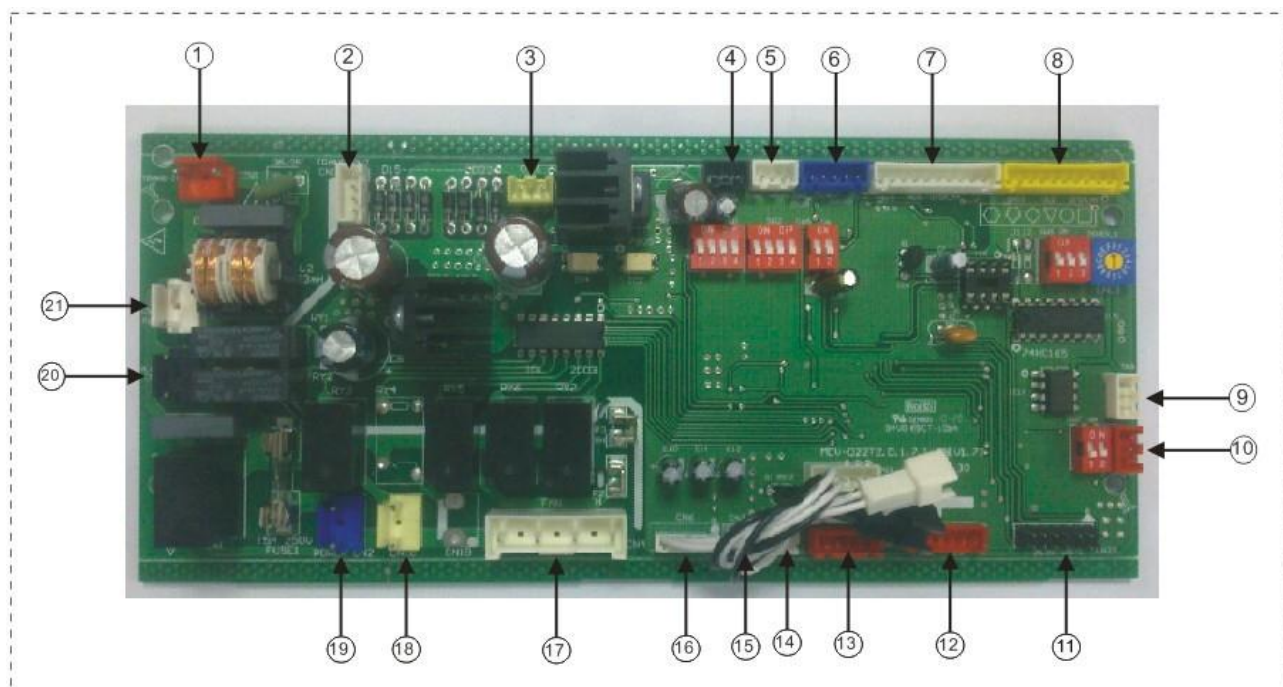

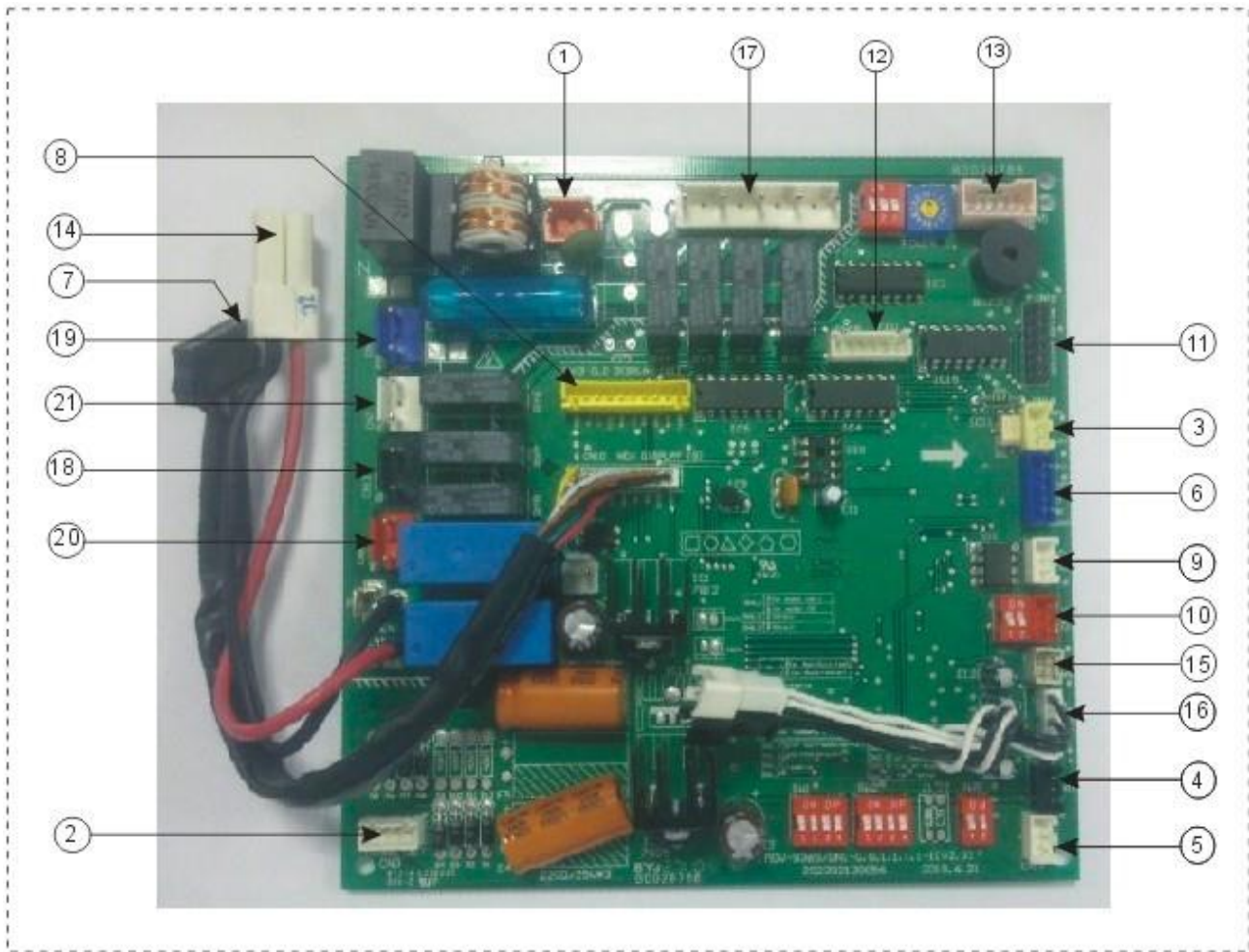

Shape 1







Shape 2

Dial codes definition

0/1 definition

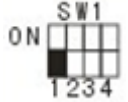
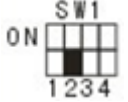
ON 	Means 0
ON 	Means 1

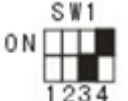

SW1 definition

ON 	1 means factory test mode 0 means default auto addressing mode	ON 	1 means DC fan is chosen 0 means AC fan is chosen
ON 	00 means DC fan static pressure is 0 (reserved)	ON 	01 means DC fan static pressure is 1 (reserved)
ON 	10 means DC fan static pressure is 2 (reserved)	ON 	11 means DC fan static pressure is 3 (reserved)

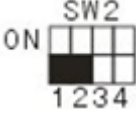
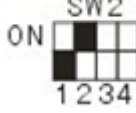
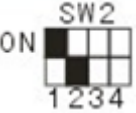
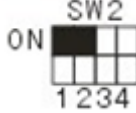
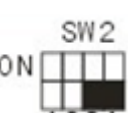
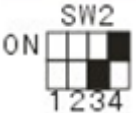
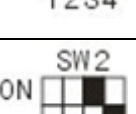
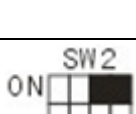

SW2 definition

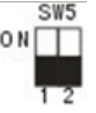
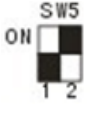
	00 means shutting down the unit to stop cold air at 15°C		01 means shutting down the unit to stop cold air at 20°C
	10 means shutting down the unit to stop cold air at 24°C		11 means shutting down the unit to stop cold air at 26°C
	00 means the time of stopping fan (when no capacity need) is 4 minutes		01 means the time of stopping fan (when no capacity need) is 8 minutes
	10 means the time of stopping fan (when no capacity need) is 12 minutes		11 means the time of stopping fan (when no capacity need) is 16 minutes

SW5 definition

	00 means temperature compensation value is 6°C under heating mode		01 means temperature compensation value is 2°C under heating mode
	10 means temperature compensation value is 4°C under heating mode		11 means temperature compensation value is 8°C under heating mode

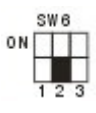

SW6 definition

	1 means old display panel 0 means new display panel		1 means auto air blow under auto mode 0 means auto air blow under non-auto mode
	reserved		

SW7 definition

	Normal configuration		Last unit of the network
---	----------------------	---	--------------------------

J1 J2 definition

	Without jumper J1 for auto restart function		With jumper J1 for non-auto restart function
	reserved		

Error code & indication

Without address when first time power on	Time LED and run LED flash together, or display FE
--	--

M_Home non-matching	4 LED flash together or display H0
Modes conflict	Defrost LED flashes or display E0
Communicative error between indoor and outdoor units	Timer LED flashes or display E1
Temperature sensor T1 error	Run LED flashes or display E2
Temperature sensor T2 error	Run LED flashes or display E3
Temperature sensor T2B error	Run LED flashes or display E4
EEPROM error	Defrost LED flash slowly or display E7
Outdoor unit error	Alarm LED flashes slowly or display Ed
Water level alarm	Alarm LED flash or display EE

Explanation of main board

No.	Content	No.	Content
1	Power input of transformer	12	Electric expansion valve drive port
2	Power output of transformer	13	Swing motor drive ports
3	Port for remote ON/OFF switch	14	Port for electric auxiliary heater
4	Port for infrared sensor	15	Indoor evaporator outlet pipe temp. detect port
5	Water level switch	16	Indoor ambient and evaporator middle part temp. detect port
6	Port for network module	17	Port for indoor fan motor
7	Port for new display board	18	Reserved
8	Port for old display board	19	Power input port
9	Communication port of X Y E	20	Port for alarm
10	Communication port of P Q E	21	Port for water pump
11	Port for on-line writing program	—	

New Added Function—Auto Addressing

- 1) New Auto-Addressing is just a newly designed indoor-address distributed method which will automatically done by outdoor unit, without manual addressing. When the unit is under testing, as the outdoor and indoor units are powered on simultaneously, the outdoor unit will automatically distribute different address to every indoor unit in less than 10 minutes.
- 2) With regarding to the customer’s desire of some kind fixed address or regular addresses for all indoor units, it can be achieved by wireless remote controller.



1.5 Electric Wiring Installations

1.5.1 Highlights of electrical installation

- 1) Please separately design the special power of indoor units and outdoor units.
- 2) The power adopts special circuit, and installs creepage protector and manual switch.
- 3) The indoor units’ power, creepage protector and manual switch connecting to the same outdoor unit must be general. All indoor units must be the same circuit, and must simultaneously on or off; otherwise,

system life will seriously effect, and appear the situation not to solve.

- 4) The communication line between indoor units and outdoor units please use 3 core shielded wiring, while don't use the multi core wiring without shielded affect, for the interference is reduced each other
- 5) Purchased wiring, parts and materials should be in compliance with the local and national regulations.
- 6) All field wiring construction should be finished by qualified electrician.
- 7) Air conditioning equipment should be grounded according to the relevant local and national electrical regulations.
- 8) Current leakage protection switch should be installed (select current leakage breaker in light of the 1.5-2 times of total loading rated current.)
- 9) When connecting wiring and wire holder, use cable clamp to fix and make sure no exposure.
- 10) Refrigerant piping system and wiring system of indoor and outdoor unit belongs to the different system.
- 11) Do not connect the power wire to the terminal of signal wire.
- 12) When power wire is parallel with signal wire, put wires to their own wire tube and remain proper gap (the current capacity of power wire is: 10A below 300mm, 50A below 500mm).
- 13) Voltage discrepancy of power wire terminal (side of power transformer) and end voltage (side of unit) should be less than 2%. If its length could not be shortened, thicken the power wire. Voltage discrepancy between phases shall not pass 2% rated value and Current discrepancy between highest and lowest phase should be less than 3% rated value.

1.5.2 Selection of wiring

1. The selection of wiring area shall in accordance with the requirements below:

- 1) Voltage lose of wire shall meet the requirement of terminal voltage for normal operation and startup.
- 2) The wiring current-carrying capacity determined by installed method and environment is not less than the largest current of unit.
- 3) Conductor shall ensure the stability of movement and heating.
- 4) The conductor's smallest sectional area should satisfy the requirement of mechanical strength.

When earth protection line (shortly called PE line) is made of material the same as phase line, the smallest sectional area of PE line should be in accordance with the regulation below:

Sectional area of core to phase line s(mm ²)	Smallest sectional area of PE line(mm ²)
$S \leq 16$	S
$16 < S \leq 35$	16
$S > 35$	S/2

1.5.3 Distribution highlights of distribution wiring

1. When distributing wiring, select wirings with different colors for phase line, zero line and protection earth according to relevant regulations.
2. The power wire and control wire of concealed engineering is prohibited to bind together with refrigerant piping. It is necessary to pass through wire tube and be distributed separately, and the gap between control line and power wire should be 500mm at least.
3. When distributing wiring by passing through pipe, the following should be paid attention to:
 - 1) Metal wire tube could be used in indoor and outdoor, but it is not suitable to the place with acid – alkali corrosion.
 - 2) Plastic wire tube is generally used in indoor and place with corrosion, but it is not suitable to situation with mechanical damage.
 - 3) The wiring through pipe shall not be in the form with ends jointing. If there must be joint, connection box should be installed at the corresponding place.
 - 4) The wiring with different voltage should not pass through the same wire tube.

5) Total sectional area of wiring through wire tube shall not exceed 40% valid area of stuffing tube.

6) Fixing point of wire tube support shall follow the standard below:

Normal diameter of wire tube Mm	Largest gap between fixed points of wire tube	
	Metal pipe	Plastic pipe
15~20	1.5m	1m
25~32	2m	1.5m
40~50	2.5m	2m

1.5.4 Outdoor unit power wiring selection

1) Separate Power Supply without power facility.

Model	Power	The shortest wiring dia. (mm)			Manual switch (A)		Creepage protector
		≤20m	≤50m	GND	Capacity	Fuse	
	380~415V 3N ~ 50Hz						
MDVi -530W/DRN1 -i(B)		4×16	4×25	16	100	70	<100mA, 0.1sec
MDVi -560W/DRN1 -i(B)		4×16	4×25	16	100	70	<100mA, 0.1sec
MDVi -850W/DRN1-i(B)		4×35	4×50	16	100	80	<100mA, 0.1sec

Note: The length in the table equals the value of power cord connecting outdoor units, indicating the condition that the voltage dropping range is within 2%. If the length exceeds the above figure, please select the wire diameter according to relevant standard.

2) With power facilities.

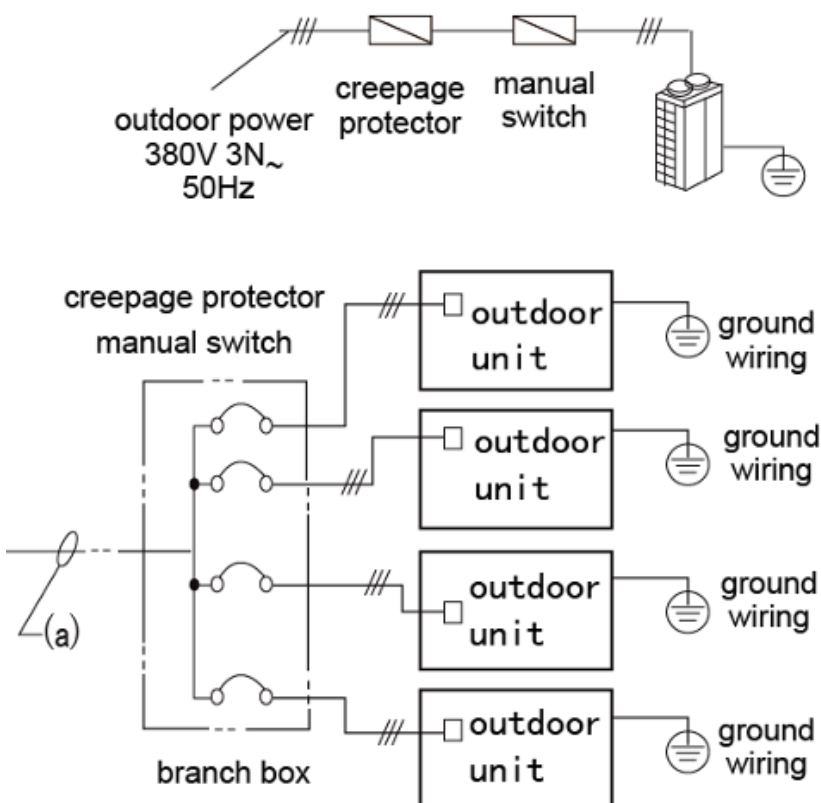

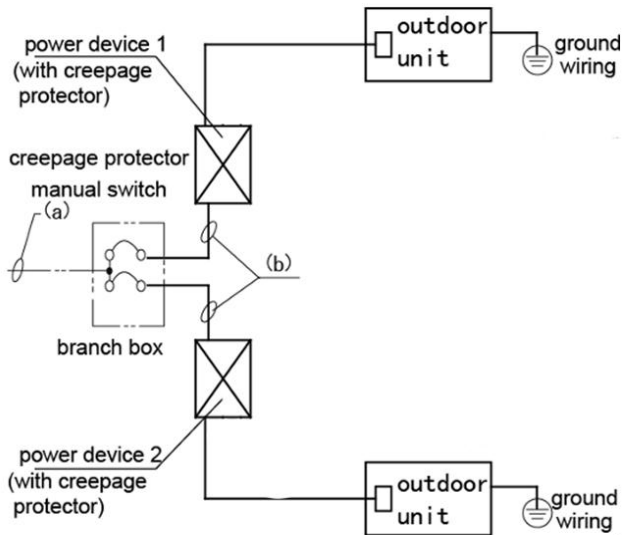

2.1) Select the wire diameter, refer to the following table. (\geq) (unit :mm²)

(unit: mm²)

Outdoor unit capacity	< 20M	< 50M	Outdoor unit capacity	< 20M	< 50M	Outdoor unit capacity	< 20M	< 50M
8	10	16	28	25	35	48	50	70
10	10	16	30	35	50	50	70	95
12	10	16	32	35	50	52	70	95
14	16	25	34	35	50	54	70	95
16	16	25	36	35	50	56	70	95
18	16	25	38	35	50	58	70	95
20	16	25	40	35	50	60	70	95
22	16	25	42	50	70	62	70	95
24	25	35	44	50	70	64	70	95
26	25	35	46	50	70		-	-

Power wiring refers to the main wire (a) connecting to branch box and the wiring (b) between branch box and power facilities. Please select the wire diameter according to the following requirement.

Diameter of main wire (a): Depends on the total horsepower of outdoor unit and the above table.

E.g. In system :(8Hp×1unit+8Hp×1unit+10Hp×1unit), total Hp=26Hp→ refer to the above table →size of wire=35 mm²(within 50m)

Diameter of wiring (b): between branch box and power equipment. Depend on the total horsepower of downward outdoor unit and the above table.

E.g. In system :(8Hp×1unit+8Hp×1unit+10Hp×1unit), total Hp=26Hp→refer to the above table→size of wire=35mm²(within 50m)

2.2) Select the capacity of manual switch and fuse of the branch box. Depend on the total horsepower.

Total capacity(HP)	Manual switch(A)	Fuse(A)	Total capacity(HP)	Manual switch(A)	Fuse(A)
10–14	75	60	29–36	150	120
15–18	100	75	37–47	200	150
19–28	150	100	48–50	200	175

1.5.5 Indoor unit power wiring selection

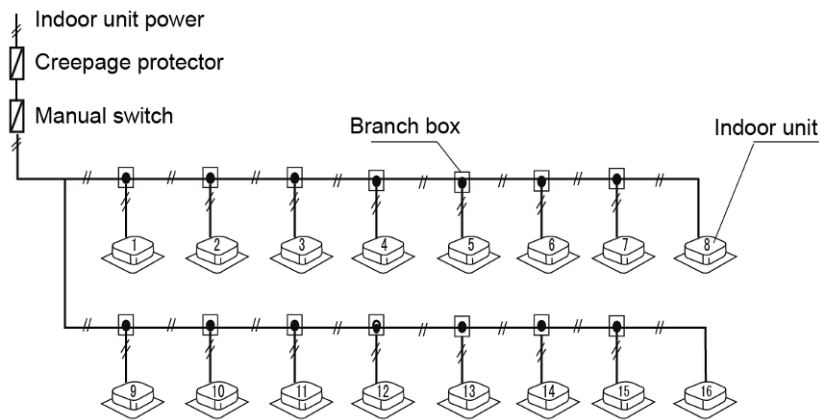

Note:

- 1) Set refrigerant piping system, signal wires between indoor-indoor unit, and that between outdoor-outdoor units into one system.
- 2) Please do not put the signal wire and power wire in the same wire tube; keep distance between the two tubes. (Current capacity of power supply: less than 10A--300mm, less than 50A--500mm.)
- 3) Make sure to set address of outdoor unit in case of parallel multi-outdoor units.

2. Control System

2.1 Control System Introduction

2.1.1 Connecting highlights of control line (RS-485 communication)

1. The control line should be shielded wire. Using other wiring shall create signal interference, thus leading to error operation.
2. The shielded nets at the two sides of shielded wires are either grounded to the earth, or connected with each other and jointed to the sheet metal along to the earth.
3. Control wire could not be bound together with refrigerant pipeline and power wire. When power wire and control wire is distributed in parallel form, keep gap between them above 300mm so as to preventing signal interference.
4. Control wire could not form closed loop.
5. Control wire has polarity, so be careful when connecting.

2.1.2 Selection of control wire specification

The ordinary shielded wire includes:

Model	Name
AVP	Copper core PVC insulation shielded wire
AVP-105	Heat-resistant 105°C PVC insulation shielded wire
RVP	PVC insulation shielded flexible wire
RVP-105	Heat-resistant 105°C PVC insulation shielded flexible wire
RVVP	PVC insulation shielded PVC sheath flexible wire
RVVP1	PVC insulation entangled shielded PVC sheath flexible wire

2.1.3 Signal wire of indoor/outdoor units

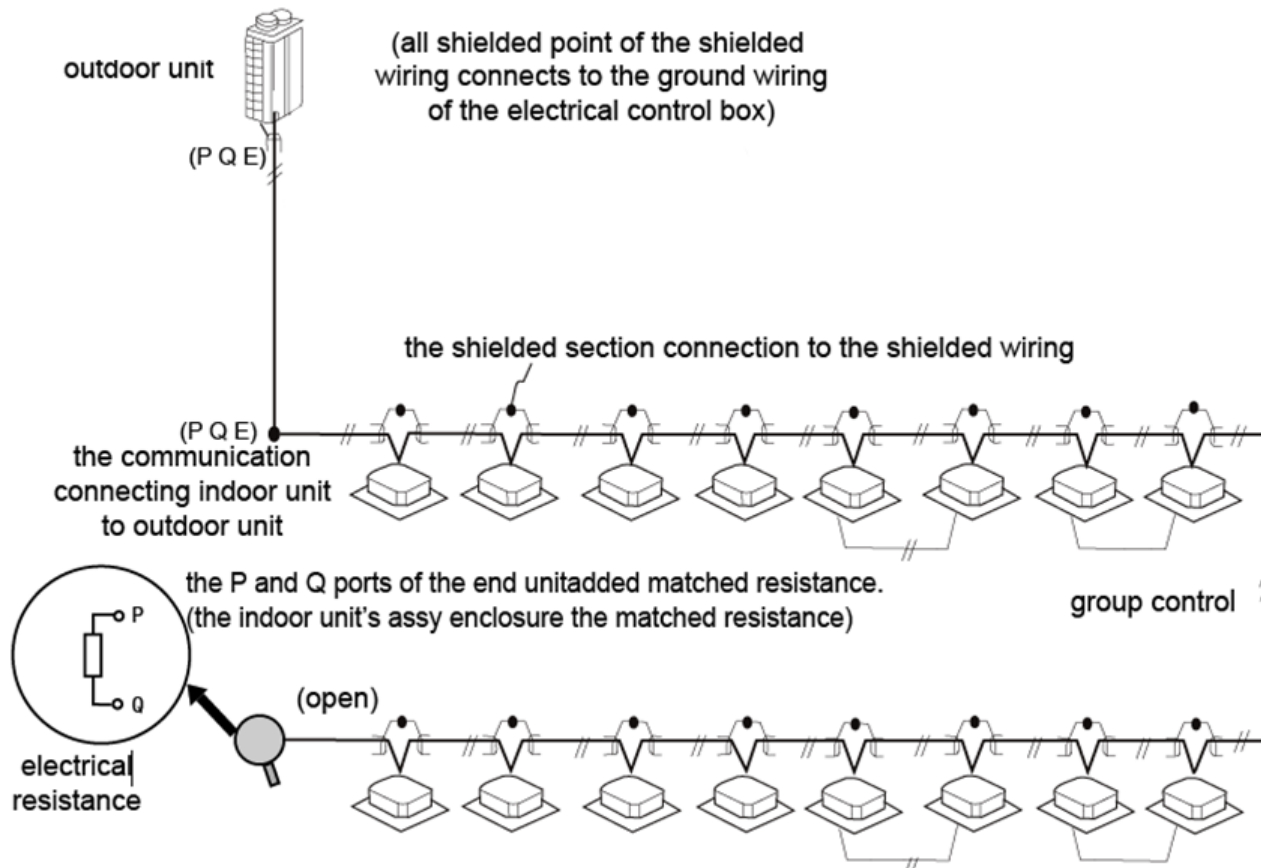

E.g. refer to the following example.

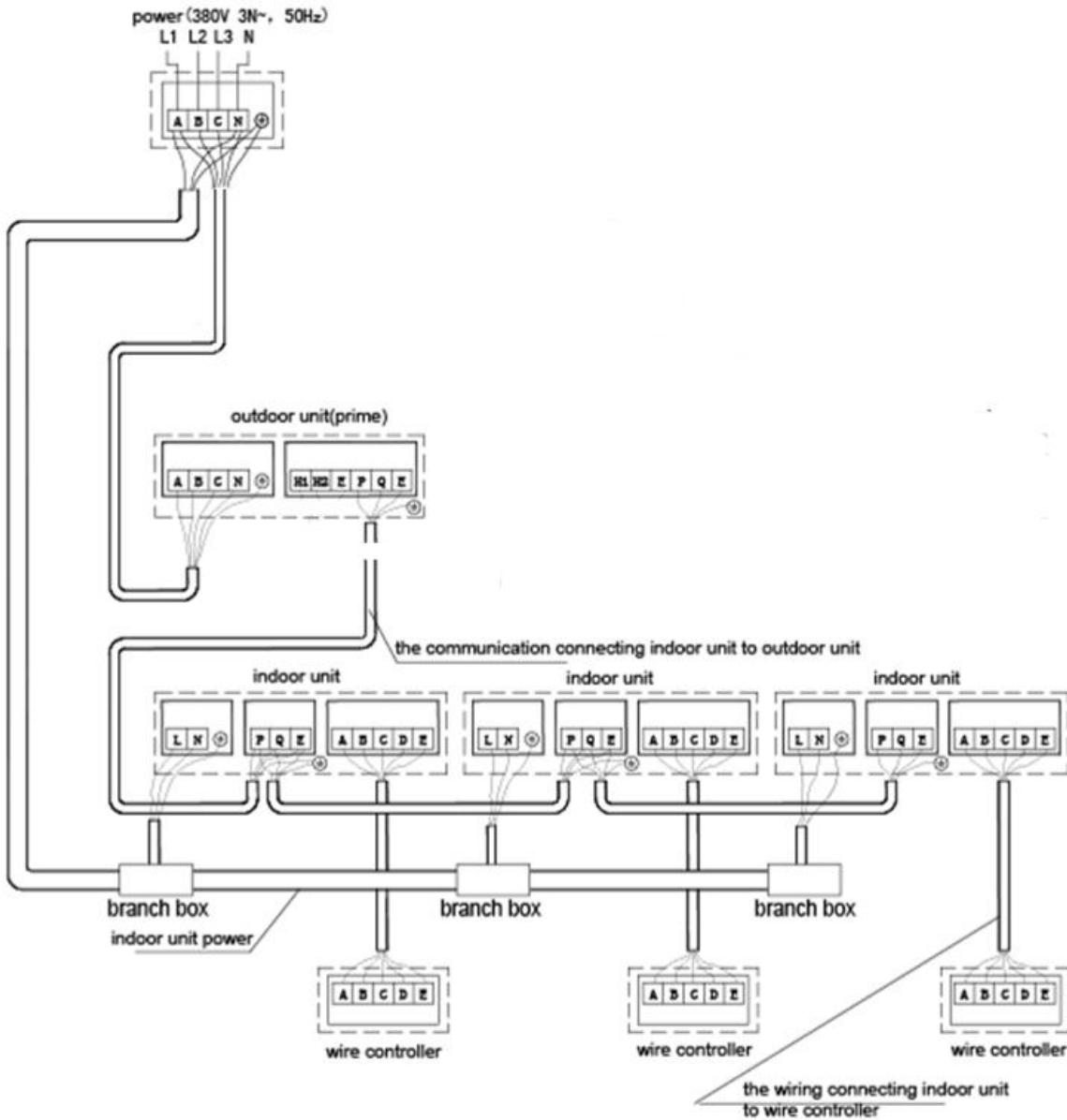

Note:

1. The signal connecting line between indoor and outdoor units and indoor units has polarity. When connecting, be careful to prevent error connection.
2. Signal wire shall adopt three-core shielded wire with the dia. no less than 0.75m².
3. The signal wire of indoor unit and outdoor unit must only connect to the prime outdoor unit.
4. Do not bind signal wire and copper pipe together with belting.

1) Correct connection

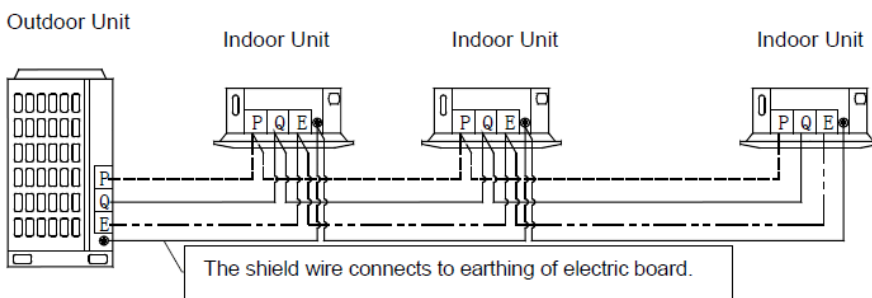

2) Typical wrong connection

- a. Loop connection of signal wire

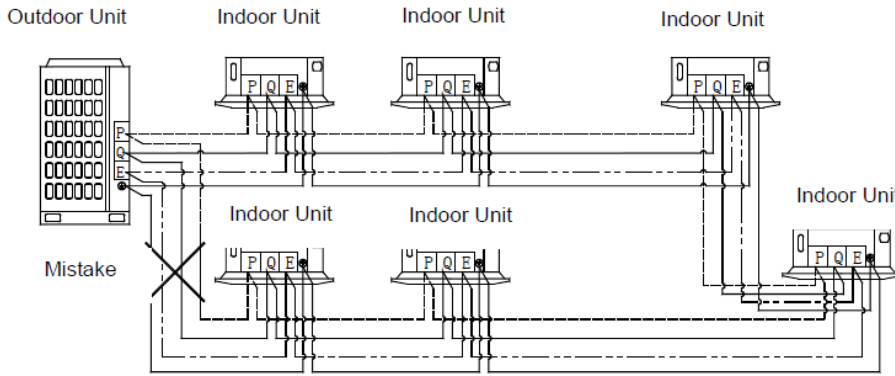

b. Star connection of signal wire

- Star connection of part signal wires

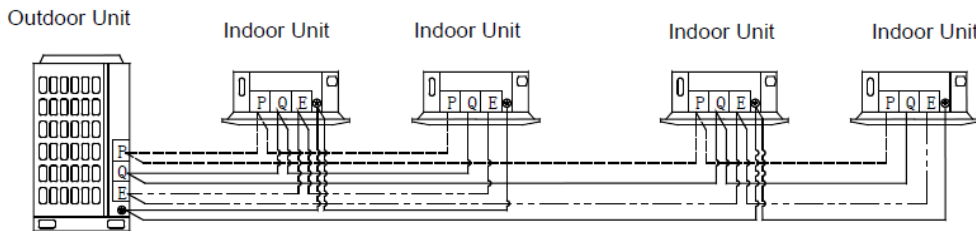

- Star connection of all signal wires

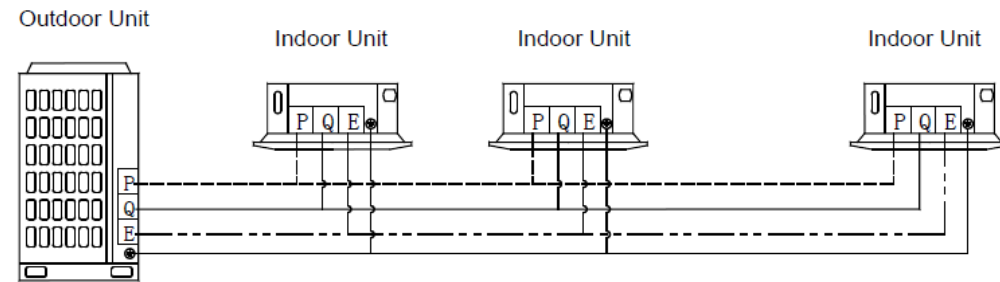

c. Reverse connection of signal wire

- Outdoor unit — indoor unit

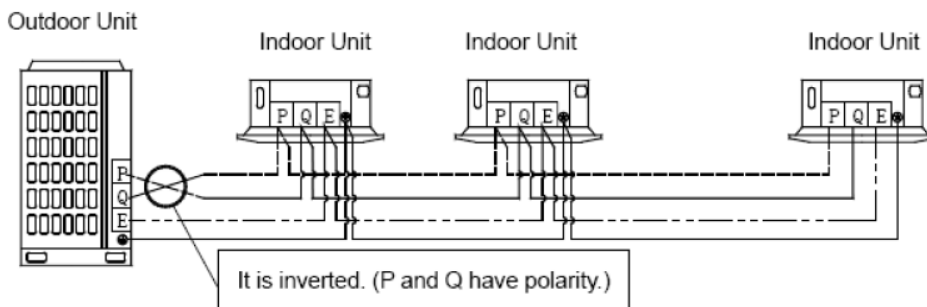

- Indoor unit — indoor unit

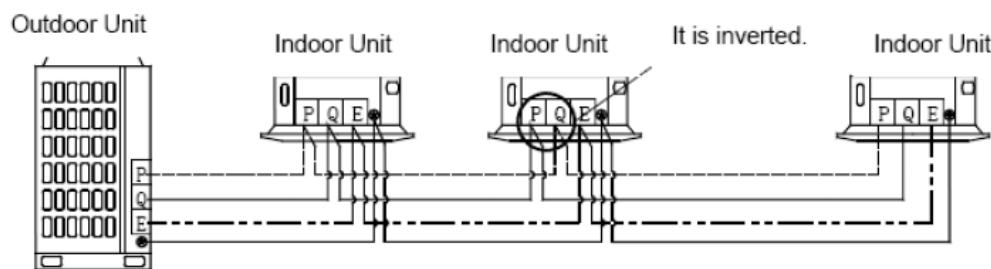

Caution: shielded layer should be connected to electrical panel.

2.1.4 Signal wire of centralized control

When centralized control is needed, one CCM03 (central controller of indoor unit) can only control the indoor units which are in the same refrigerant system **via the port X Y E of outdoor unit**. Outdoor unit will

automatically distribute the address to indoor units without any manual setting. Remote controller can enquiry and modify every indoor unit address.



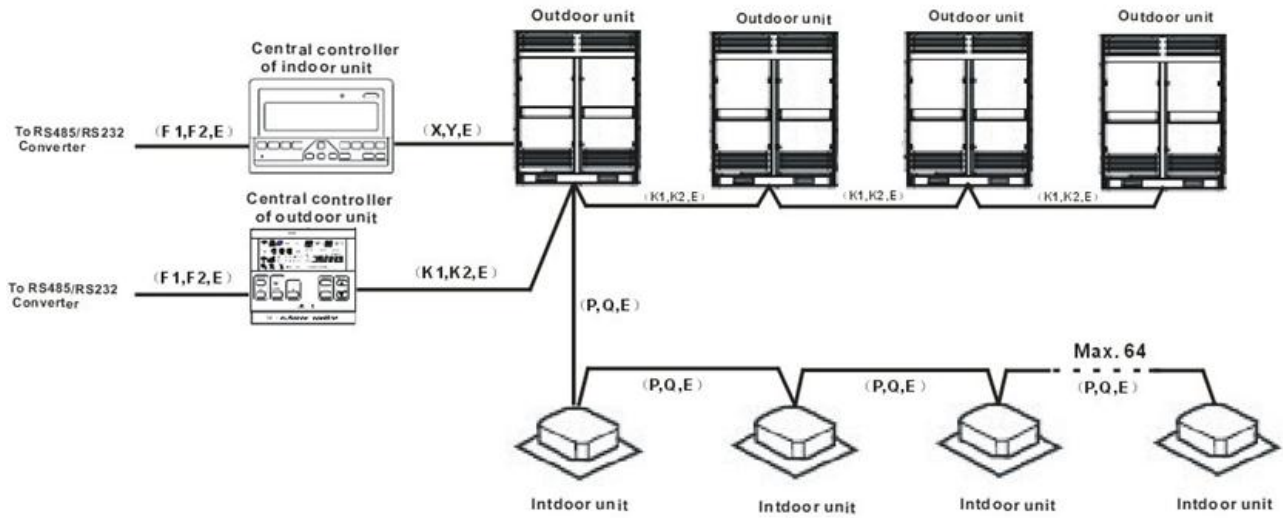



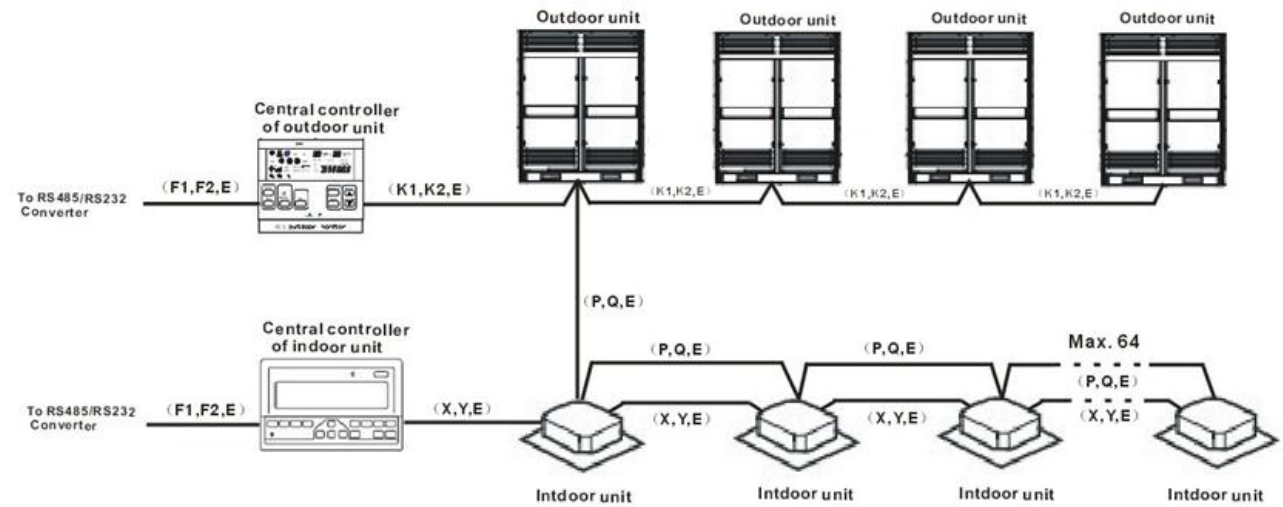

The diagram below shows the connection of signal wire in this case:













Besides, CCM03 can also connect indoor units **via the port X Y E of indoor unit**. However, one more group of wire(X Y E between indoor units) is needed; it is more complex and not suggested. Anyway, the diagram below shows the connection of signal wire in this case:









2.1.5 Controller introduction

Controller and assy.	Appearance	Model	Description
Wireless remote controller		R51C/BGE	More the following functions than general wireless remote controller: add water, add humid, exchange air, fresh air, and etc.
		R51I4/BGE	General functions with backlight and FOLLOW ME.
		R51D/E	General functions.
		R51/E	General functions and without economic mode.
		R71/(C)E	Based on R51C, button quantities reduce, but functions increase.
		R05/BGE	Big screen and LCD display, with back light display, clock function.
		R06/BGE	The function is the same as R05/BGE, and only the appearance is different.
		R06/BGCE	For cooling only mode. The function is the same as R05/BGE, and only the appearance is different.
		RM05/BG(T)E-A	General remote functions with address setting function,
		R11HG/E	General functions with time display.
Wired controller		KJR-10B/DP(T)-E	Connection needs that the indoor unit display panel contains a corresponding port.
		KJR-10B/DPC(T)-E	The function is generally the same as the KJR-10B/DP(T)-E, but excluding the heat mode.
		KJR-12B/DP(T)-E	This controller integrate FOLLOW ME function, others is the same with KJR-10B/DP(T)-E.
		KJR-12B/DPBG(T)-E	Based on the KJR-12B/DP(T)-E and designed with backlight.
		KJR-90A	All basic function is the same as KJR-10B/DP(T)-E.
		KJR-90A1-E	To avoid mode confliction running mode is fixed to cool mode, other functions are the same as KJR-90A.

Central control monitor		MD-CCM01/E	1st generation central control monitor of indoor unit. Control Max 64 indoor units. It may set and check only one indoor unit, and also set and check all indoor units in common. PC control function may connect 2nd generation or 3rd generation network control system.
		MD-CCM03/E (M)	2nd generation central control monitor of indoor unit. Add mode lock, big screen appearance, blue back light display, and mode memory function based on MD-CCM01/E.
		MD-CCM09/E	The weekly central controller of indoor unit. Control Max. 64 indoor units and possess week schedule function, but cannot connect network control system.
		KJR-90B/M	New general controller of indoor unit. It is only switch, which cannot change special mode, but it can simultaneously switch max. 16 indoor units.
		MD-CCM02/E	The central control monitor of outdoor unit. Monitor max. 32 outdoor units.
Building gateway		MD-CCM07/E	Building gateway connects to Lonworks® network for integrating to other BMS to realize air conditioner manage and control. It needn't match Midea network system and PC.
		MD-CCM08/E	Building gateway connects to BAKNET network for integrating to other BMS to realize air conditioner manage and control. It needn't match Midea network system and PC.
Network control software		MDV-WLJKXT/E(V3.1)(Firebird)	The 3 rd generation network control software with Firebird data. Add network fee charge function and connect the outdoor unit CCM based on the 2 nd generation network central control system. It may connect to 16 indoor unit CCM and 1024 indoor units, and also connect to 16 outdoor unit CCM and 128 refrigeration systems.
Hotel card-insert r assy.		MD-NIM05/E	Match hotel card system to control the air conditioner.
Digital ammeter		DTS634/DT636	Send the electric energy data to outdoor unit for realizing network fee charge function.
Infrared sensor		MD-NIM09/E	Automatically turn off and turn on the indoor unit, saving energy.

2.2 Wireless Remote Controller

Controller	Appearance	Model	Description
Wireless remote controller		R51C/BGE	More the following functions than general wireless remote controller: add water, add humid, exchange air, fresh air, and etc.
		R51D/E	General functions.
		R51/E	General functions and without economic mode.
		R51I4/BGE	General functions with backlight and FOLLOW ME.
		R71/(C)E	Based on R51C, button quantities reduce, but functions increase.
		R05/BGE	Big screen and LCD display, with back light display, clock function.
		R06/BGE	The function is the same as R05/BGE, and only the appearance is different.
		R06/BGCE	For cooling only mode. The function is the same as R05/BGE, and only the appearance is different.
		R11HG/E	General functions with time display.
		RM05/BG(T)E-A	General remote functions with address setting function,

2.2.3 Wireless remote controller R05/BGE, RM05/BG(T)E-A

Apply to Ceiling and floor type / four-way cassette type.

Model	R05/BGE
Rated Voltage	3.0V(2 pieces of LR03 7# batteries)
Lowest Voltage	2.4V
Effective Distance	8M~11M
Operation Condition	-5°C~60°C

2.2.3.1 Buttons and functions descriptions

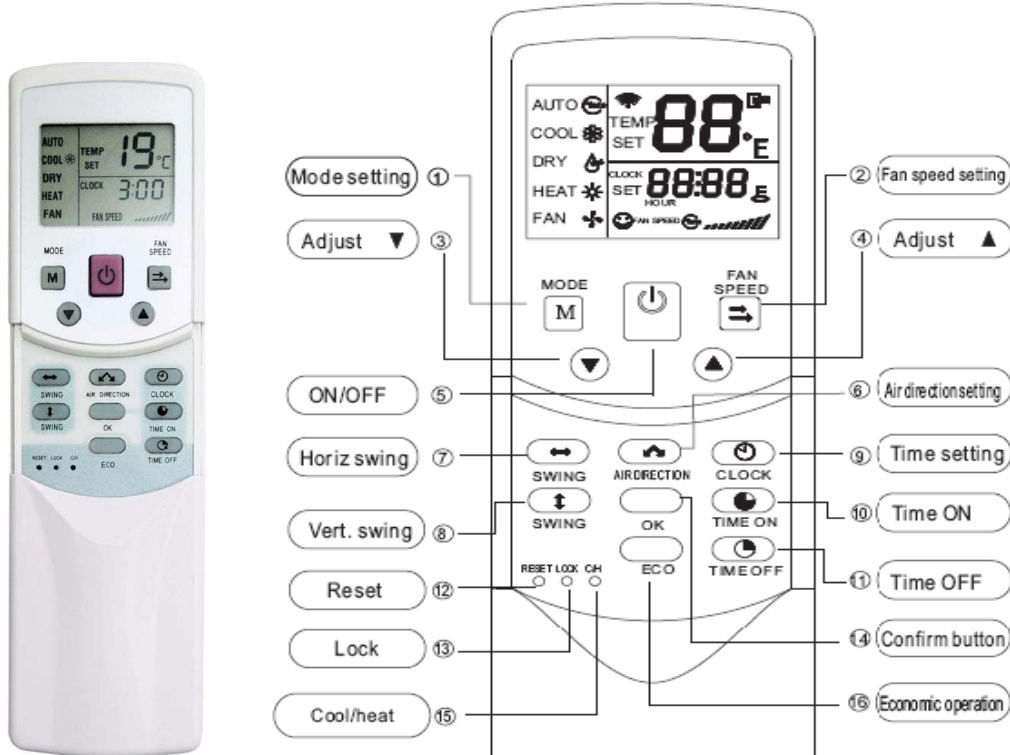

1. MODE: Each time you push the button, a mode is selected as the following figure indicates:

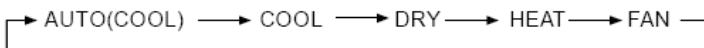

Note: "HEAT" is only for heat pump AC.

- 2. FAN SPEED:** This button is used for setting Fan Speed in the sequence that goes from AUTO, LOW, MED to HIGH, then back to Auto.
- 3. TEMP:** Push the TEMP button to decrease the indoor temperature setting or to adjust the TIMER in a counter-clockwise direction.
- 4. TEMP:** Push the button to increase the indoor temperature setting or to adjust the TIMER in a clockwise direction.
- 5. ON/OFF:** Push this button to start the unit operation. Push the button again to stop the unit operation.
- 6. SWING:** Push this switch button to change the louver angle.
- 7. CANCEL:** Push this button to cancel the TIMER settings.
- 8. Air direction:** Activate swing function of air deflector. Once pressed, air deflector will turn 6 degrees.
- 9. CLOCK:** Use to set the time.
- 10. TIME ON:** turn on the timer operation.
- 11. TIME OFF:** turn off the timer operation.

- 12. RESET:** Pushed, all current settings are cancelled and the control will return to the initial settings.
- 13. LOCK:** Push this button to lock in all the current settings. To change the settings, push the button once more.
- 14. OK:** Used to confirm the time settings and modification.
- 15. C/H:** Used this button to change the machine to Cooling mode or Cooling/Heating mode.
- 16. ECONOMIC RUNNING:** Push this button to go into the Energy-Saving operation mode.

2.2.3.2 LCD display indications:

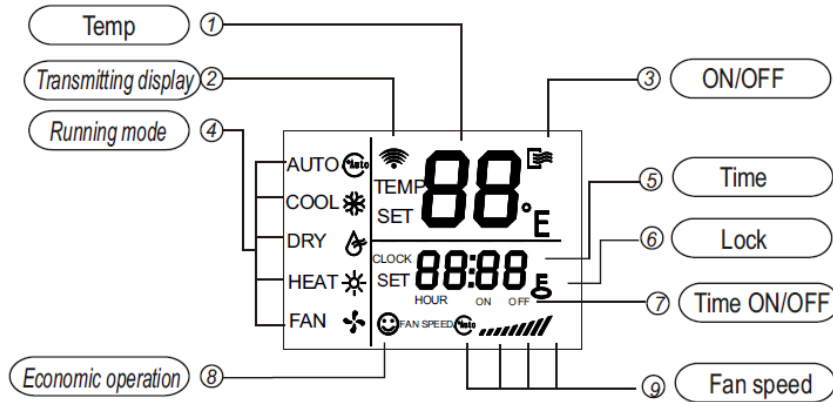









- % < **Temp:** Display the setting temperature.
- % < **Transmitting display:** This indicates that the remote controller is sending data.
- % < **ON/OFF:** This indicates that the machine is on .
- % < **Running mode:** This indicates the machine's running mode. Heating mode need the corresponding type of unit.
- % < **Time:** Display the current time. User could press the CLOCK button for 5s to make this flash, then user could adjust the time by using the ▲ and ▼ buttons. Once time is right, press the OK button to confirm it.
- % < **Lock:** When displayed, all the button is ineffective except the lock button.
- % < **Timer ON/OFF:** This indicates the timer is working or not.
- % < **Economic operation:** Indicates that whether the machine is working at the economic operation.
- % < **Fan speed:** Shows the indoor unit's fan speed. The longer it's displayed, the stronger the wind blows.

Note: RM05/BG(T)E-A is able to set the indoor units' addresses individually. The details please refer to the summary.

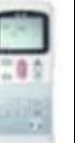
Summary:

Comparison of remote controllers

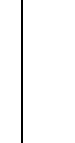
Function										
	R05/BGE	RM05/BG(T)E-A	R06/BGCE	R06/BGE	R11HG/E	R51C/BGE	R51D/E	R51/E	R51I4/BGE	R71A/E
On/Off	●	●	●	●	●	●	●	●	●	●
Cooling mode	●	●	●	●	●	●	●	●	●	●
Heating mode	●	●	—	●	●	●	●	●	●	●
Fan mode	●	●	●	●	●	●	●	●	●	●
Dehumidifying mode	●	●	●	●	●	●	●	●	●	●
Auto mode	●	●	●	●	●	●	●	●	●	●
Swing function	●	●	●	●	●	●	●	●	●	●
Economic mode	●	●	—	—	●	●	●	—	●	●
Remote controller lock	●	●	●	●	●	●	●	●	●	●
Fan speed control	●	●	●	●	●	●	●	●	●	●
Daily time setting	●	●	—	—	●	—	—	—	—	—
Background light	●	●	●	●	—	●	—	—	●	—
Current time	●	●	—	—	●	—	—	—	—	—
FOLLOW ME	—	—	—	—	—	—	—	—	●	—
Address setting	—	●	—	—	—	—	—	—	—	—

How to set address through Wireless Remote Controller



- 1) Press the LOCK button for more than 5 seconds, then the controller get into address setting mode.
- 2) Then press the ON/OFF button to start transmitting signal in the address setting mode. When working in address setting mode, press ON/OFF will not turn the controller off.
- 3) In the address setting mode, there are 2 main functions:

Querying mode: Please point the remote controller to the indoor unit, then press MODE button, the corresponding indoor unit will display its address.

Setting mode: Use the UP and DOWN buttons to choose an address you want. Then point the remote controller to the indoor unit and then press the FAN button to set the indoor unit's address. The corresponding indoor unit will display the new address and record it. After about 4 seconds, this displaying will fade out and the indoor unit turn to normal display mode.

4) After setting all the addresses, users can press the LOCK button for 5 seconds to quit the address setting mode.

2.3 Wired Controller

Controller	Appearance	Model	Description
Wired controller		KJR-10B/DP(T)-E	General control function. Connected to the indoor unit display panel's corresponding port.
		KJR-10B/DPC(T)-E	The function is generally the same as the KJR-10B/DP(T)-E, but excluding the heat mode.
		KJR-10B/DP(T)-E(Korean)	A Korean Edition bases on the KJR-10B/DP(T)-E.
		KJR-12B/DP(T)-E	This controller integrate FOLLOW ME function, others is the same with KJR-10B/DP(T)-E.
		KJR-12B/DPBG(T)-E	Bases on the KJR-12B/DP(T)-E and is with backlight, vertical and level swing function.
		Dun-KJR-12B/DP(T)-E	FOLLOW ME and configured with a 20M wire. There's no brand and backlight on it.
		KJR-90A	All basic function is the same as KJR-10B/DP(T)-E.
		KJR-90A1-E	To avoid mode confliction running mode is fixed to cool mode, other functions are the same as KJR-90A.

Safety precautions:

Please read this safety precaution carefully, before installation. Do observe the following safety precautions, for they are very important.

Confirm there is no abnormal phenomenon during test operation after installation completed, then hand the manual to the user.

Installation must be conducted by professionals;

Improper installation may cause electric shock or fire;

A random disassembly may cause abnormal operation or heating, which may result in fire.

Don't install it in a place where combustible gas easily leaks. Once combustible gas leaks and remains around Controller, fire may be caused.

Wire must be suitable for the current of Controller. Otherwise electricity leakage or heating may be caused, which may result in fire.

Wire must be suitable for controller, never bring outside force to bear on the terminal. Otherwise wire break or heating may be caused, which may result in fire.

Installation location:

Do not install it in a place with oil, steam or sulphur gas, or else deform or malfunction may occur.

Wire controller installation notice:

1. This installation manual contains information about the procedure of installing Wire Controller.
- Please refer to Indoor Unit Installation Manual for connecting between Wire Controller and Indoor Unit.
2. Circuit of Wire Controller is low voltage circuit. Never connect it with a standard 220V/380V circuit or put it into a same Wiring Tube with the circuit.
3. The shield cable must be connected stable to the ground, or transmission may fail.
4. Do not attempt to extend the shield cable by cutting, if it is necessary, use Terminal Connection Block to connect.
5. After finishing connection, do not use Megger to have the insulation check to the signal wire.

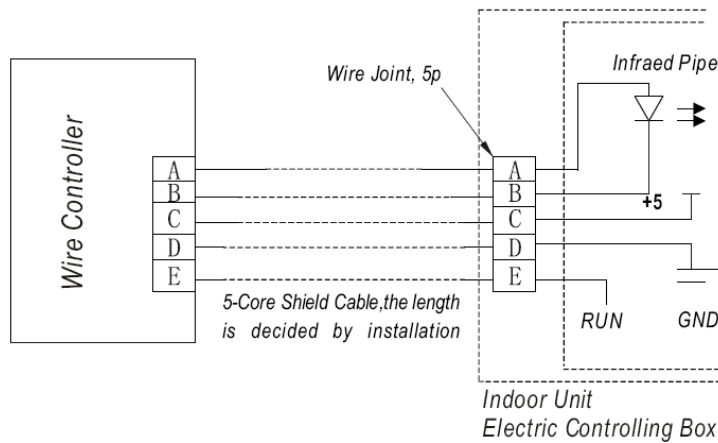

Note: When the air conditioner needs the constant frequency wire Controller, be sure adding a Wire Joint with 5 terminal named A, B, C, D, E in indoor unit, and fixing a infrared emitter whose anode and cathode connecting with A and B near the receiver in the Indoor Unit Switch Board, then connecting the terminal +5V, GND, Run in the Switch Board to C, D, E respectively.

2.3.1 Wired controller KJR-10B

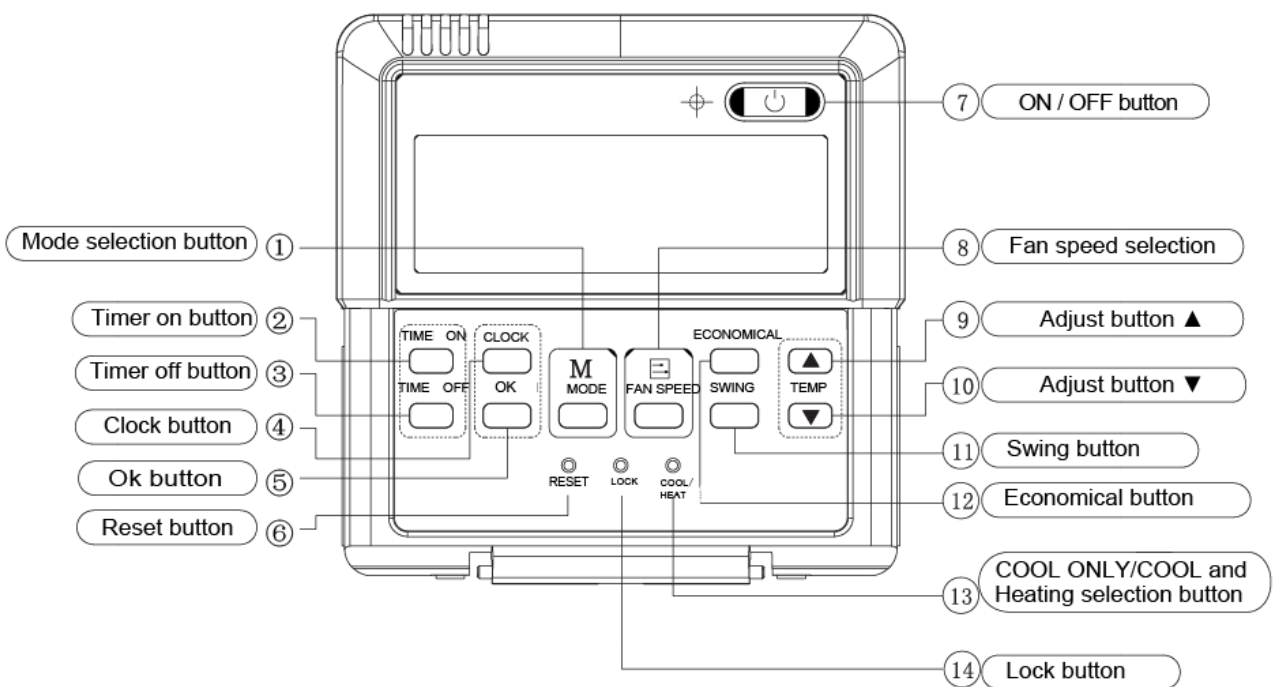

2.3

.1.1 Appearance

Apply to One-way/four way cassette/ Concealed duct/ Ceiling and floor/ Wall mounted type

Button ₁₃: For some machines with auxiliary electric heater, this button may help with change the machines in to cooling mode only. Factory default setting is cooling and heating mode both exist. Some types do not have this button.

2.3.1.2 Installation

Dimensions:120*120*15mm

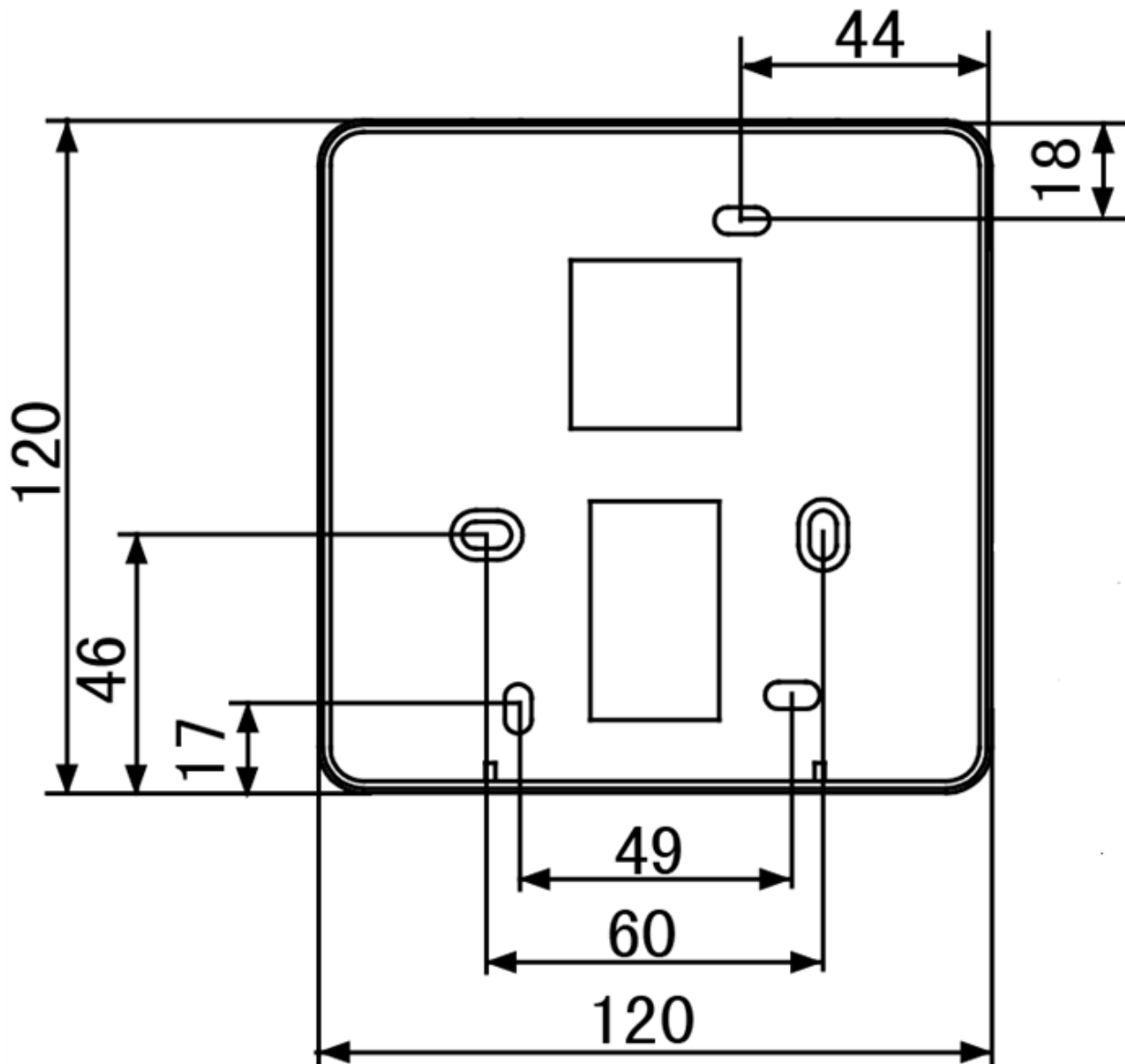

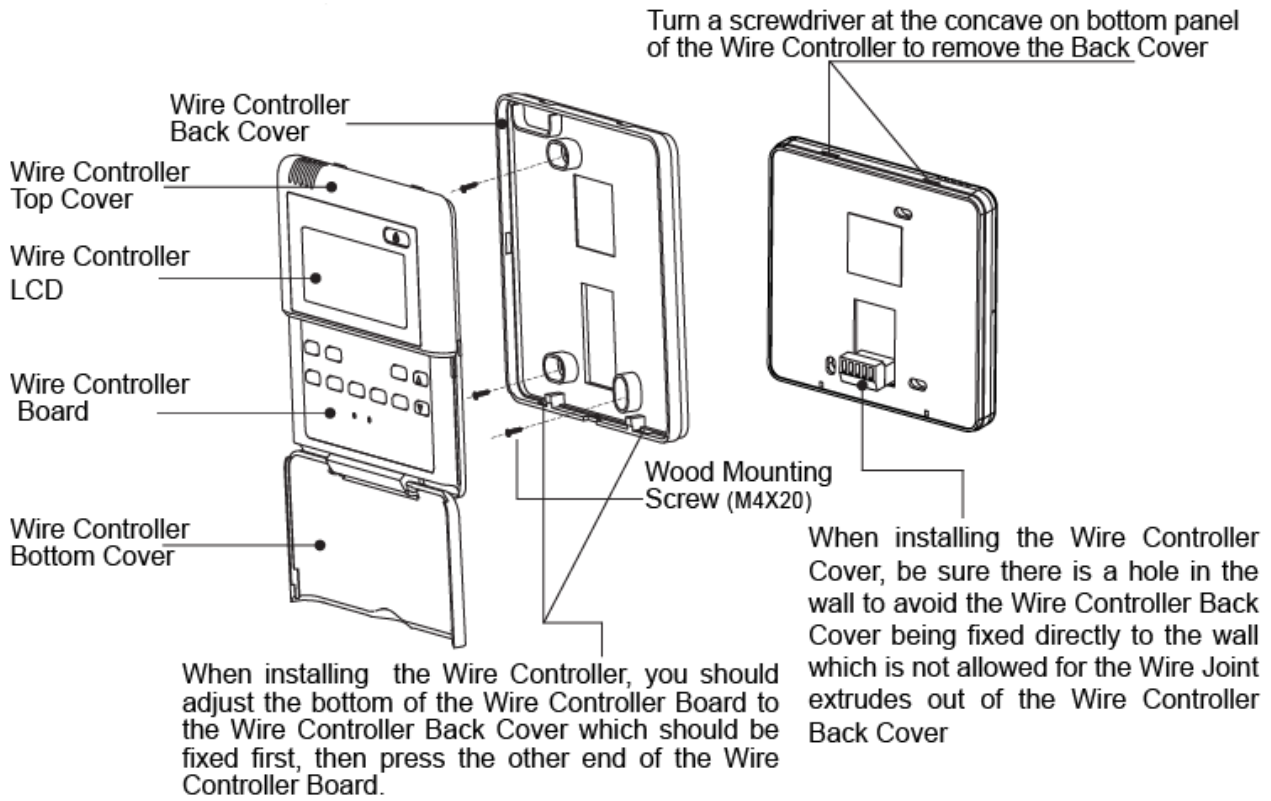

Preparation before Installation:

Make sure the following parts has been prepared.

NO.	Name	QTY.	Remarks
1	Wire Controller	1	With Cover
2	Wood Mounting Screw	3	M4×20(For mounting on the wall)
3	Mounting Screw	3	M4×25(For Mounting on the electrical switch box)
4	Installation Manual	1	-
5	Owner's Manual	1	-

Prepare for the following at installation site.

NO.	Name	QTY.		Remarks
		Install into the wall	Install on the wall	
1	5-core Shield Cable	1	1	0.05mm ² ×5 Cable no more than 15M
2	Switch Box	1	-	-
3	Wiring Tube(Insulating Sleeve and Tightening Screw)	1	-	-

Note: Do not turn screws too tightly, or else the cover would be sunk or the Liquid Crystal may be broken.

2.3.2 Wired controller KJR-12B

2.3.2.1 Appearance

Apply to the customized indoor unit.

Add ambient temperature displaying function based on KJR-10B/DP(T)-E.

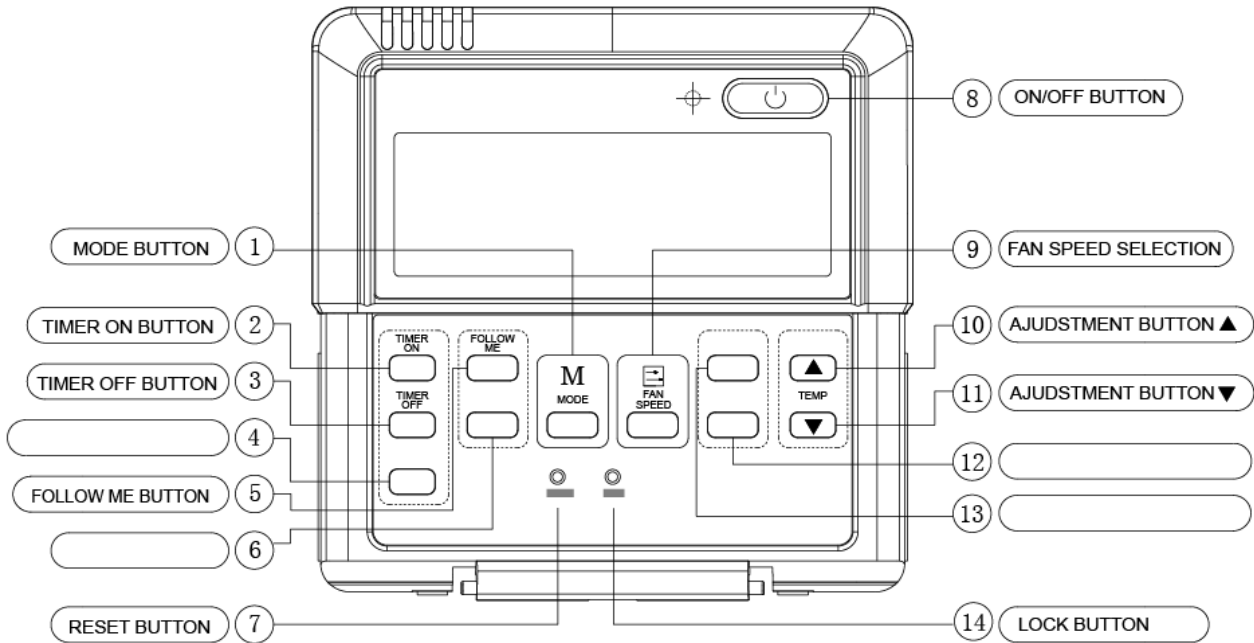

Button ○,4: This button is not designed on all the types. If exists, it stand for economic running mode.

Button ○,6: There are 2 type of this button.

AUXIL HEATER: Auxiliary electricity heater.

TURBO: In cooling mode, this button stands for powerful cooling mode, available to some mode designed with this function. In heating mode, this button will cause electric auxiliary ineffective.

Button ○,12: Pattern means the vertical swing function and "SWING" means the normal swing function.

Button ○,13: Pattern means the horizontal swing function and "ECO" means the economic function.

2.3.1.2 Installation

General Information

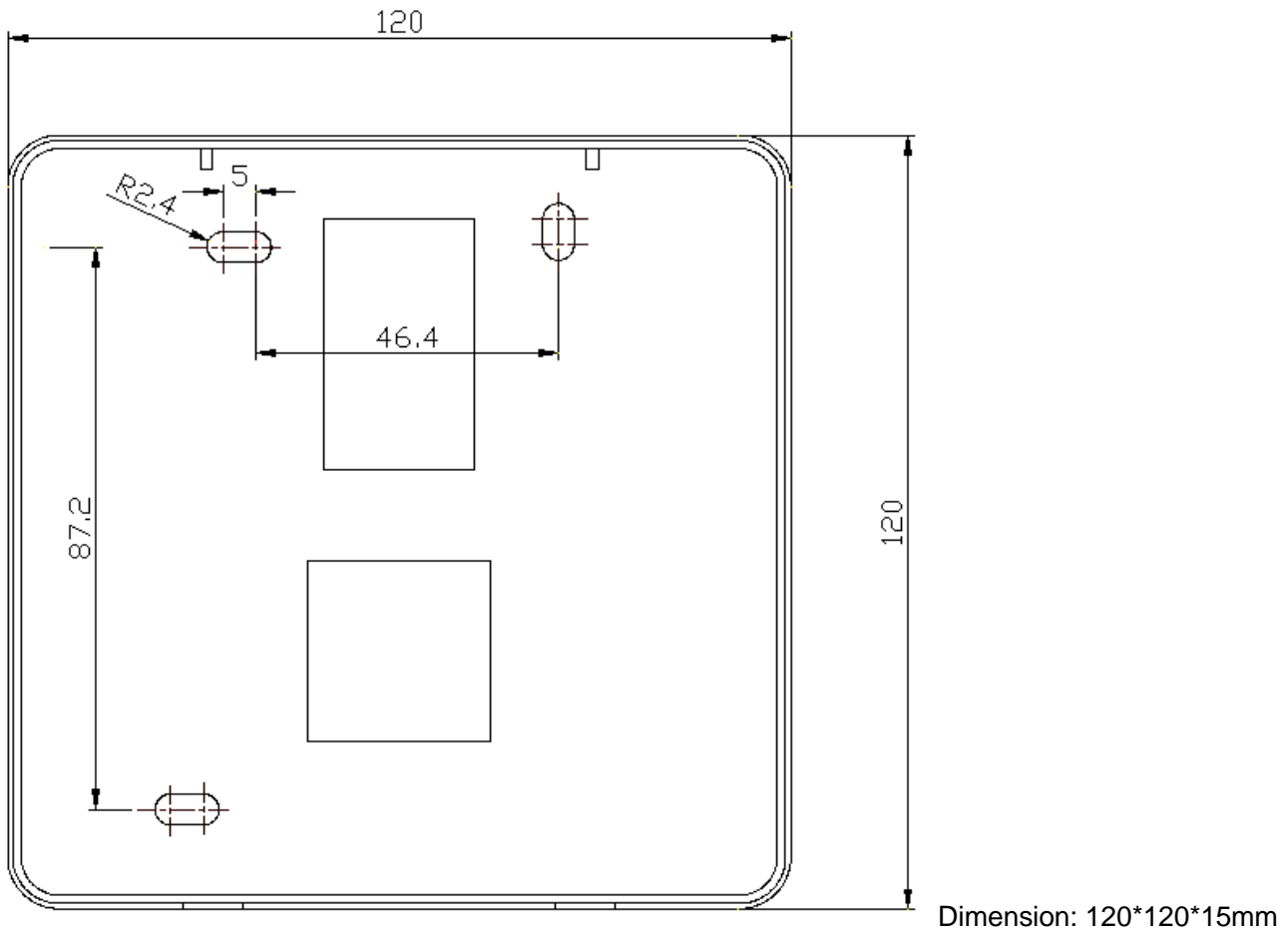

Installation of wire controller:

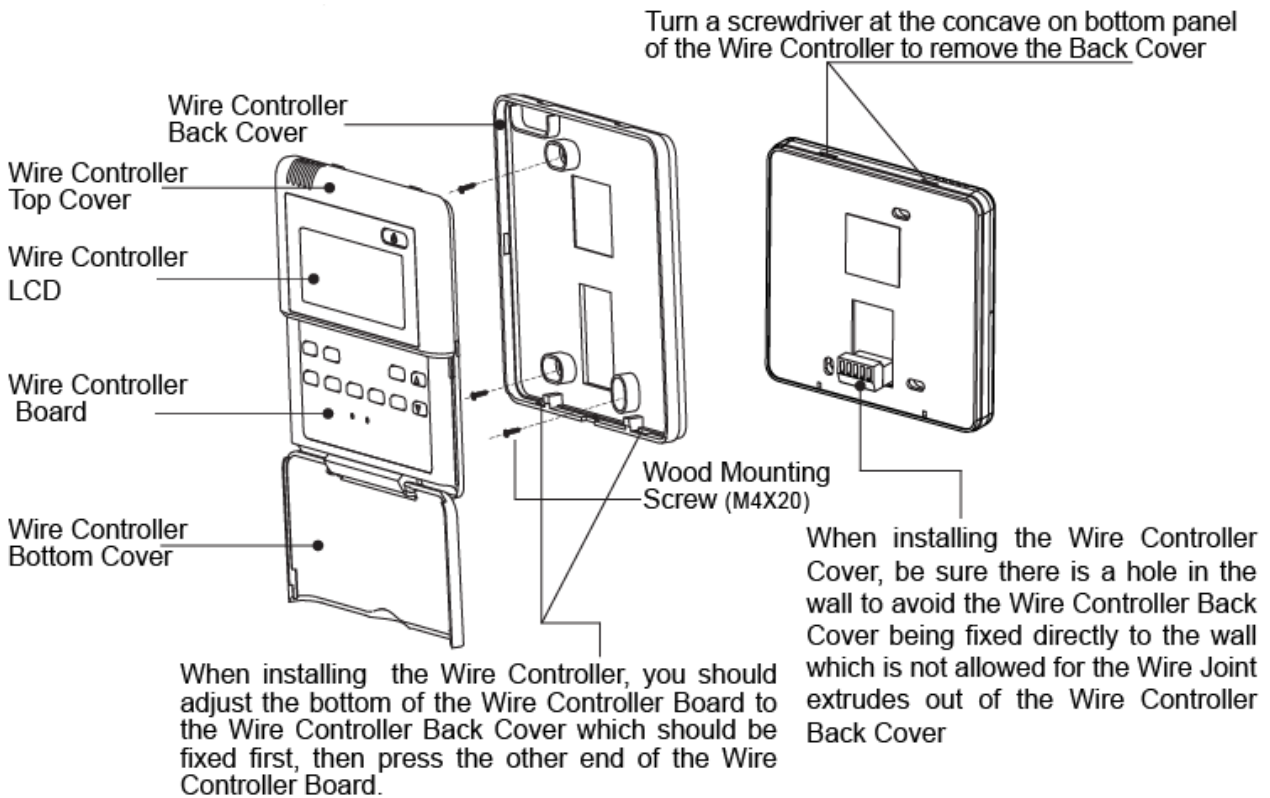

Preparation before Installation:

Make sure the following pasts has been prepared.

NO.	Name	QTY.	Remarks
1	Wire Controller	1	With Cover
2	Wood Mounting Screw	3	M4×20(For mounting on the wall)
3	Mounting Screw	3	M4×25(For Mounting on the electrical switch box)
4	Installation Manual	1	-
5	Owner's Manual	1	-

Prepare for the following at installation site.

NO.	Name	QTY.		Remarks
		Install into the wall	Install on the wall	
1	5-core Shield Cable	1	1	0.05mm ² ×5 Cable no more than 15M
2	Switch Box	1	-	-
3	Wiring Tube(Insulating Sleeve and Tightening Screw)	1	-	-

Note:

Never turn screws too tightly, or else the cover would be sunk or the Liquid Crystal breaks.







Installation of wired controller KJR-12B/DP(T)-E is the same to KJR-10B/DP(T)-E.

Summary

Comparison of wired controllers

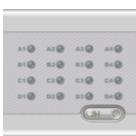
appearance								
Model	KJR-10B/ DP(T)-E	KJR-10B/ DPC(T)- E	KJR-10B/ DP(T)-E(Korean)	KJR-12B/ DP(T)-E	KJR-12B/ DPBG(T) -E	Dun-KJR -12B/DP(T)-E		
On/off	●	●	●	●	●	●		
Auto	●	●	●	●	●	●		
Cooling	●	●	●	●	●	●		
Dehumidify	●	●	●	●	●	●		
Fan	●	●	●	●	●	●		
Heating	●	-	●	●	●	●		
On/off Timer	●	●	●	●	●	●		
Temp. Setting	●	●	●	●	●	●		
Horizon Swing	●	●	●	●	●	●		
Vertical Swing	-	-	-	-	●	-		
Economical mode	●	●	●	●	●	●		
FOLLOW ME	-	-	-	●	●	●		
Backlight	-	-	-	-	●	-		
Powerful cooling	-	-	-	-	●	-		
Lock mode	●	●	●	●	●	●		
Cooling/Cooling & Heating Selection	●	-	●	-	-	-		
Electric Auxiliary Heating ON	-	-	-	-	-	●		

2.4 Central Control Monitor

Controller	Appearance	Model	Description
Centralized Controller		MD-CCM03/E(M)	No.2 generation central control monitor of indoor unit. Add mode lock, big screen appearance, blue back light display, and mode memory function based on MD-CCM01/E.
		MD-CCM09/E	The weekly schedule central controller of indoor unit. Control Max. 64 indoor units and possess week schedule function, but cannot connect network control system.
		KJR-90B/M	New general controller of indoor unit. It is only switch, which cannot change special mode, but it can simultaneously switch max. 16 indoor units.
		MD-CCM02/E	The central control monitor of outdoor unit. Monitor max. 32 outdoor units.
		KJRF-180A/M BT-E	Be able to control up 16 indoor units and a water heater, including one fresh air unit.
		KJR-31B/E	Be able to lock up to 64 indoor units' running mode to avoid modes conflict.

2.4.1 Central control monitor MD-CCM03/E(M)

Central control monitor MD-CCM03/E(M) is a remote wired controller that is used for controlling up to 64 indoor unit. Moreover, we could create our AC network with this device, including the PC central monitoring system and the BMS(Building Management System).



- Clear & bright LCD display screen,
- Background light, more parameters display
- Emergency ON/OFF control with simple dry contact input

- Memory function: It can record the running parameters (mode/fan speed/temp.) when using the controller to turn on the indoor units, all the unit will work as the last setting.
- Automatically record all setting info when lose power
- RS485 communication protocol

2.4.1.1 System configure

With MD-CCM03/E(M), we could both centrally control the indoor units and bridge up to 64 indoor units to the PC monitoring software or BMS. In fact, on the purpose of connecting the indoor units to the PC or the gateway, which makes the indoors units visible and can be controlled, MD-CCM03/E (M) is necessary.

1. All the indoor units and outdoor units are V4+ series, the topology of the network is as follows:

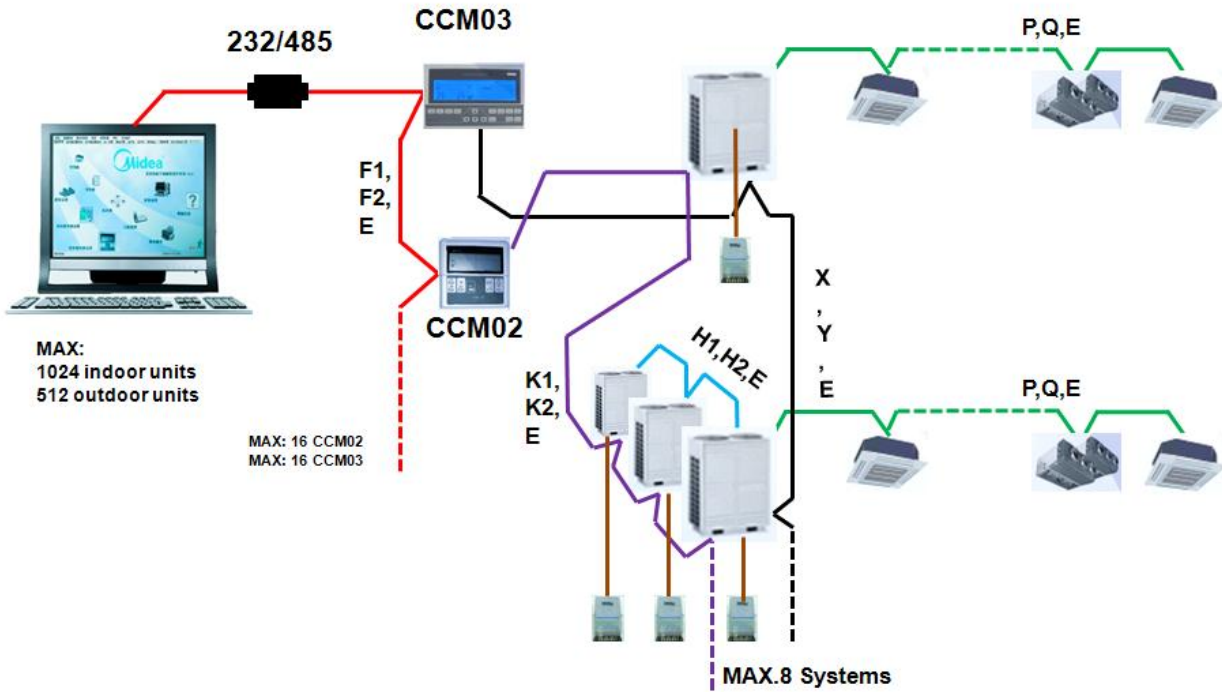

2. The indoor units contains any V4 series, the network topology is as follows:

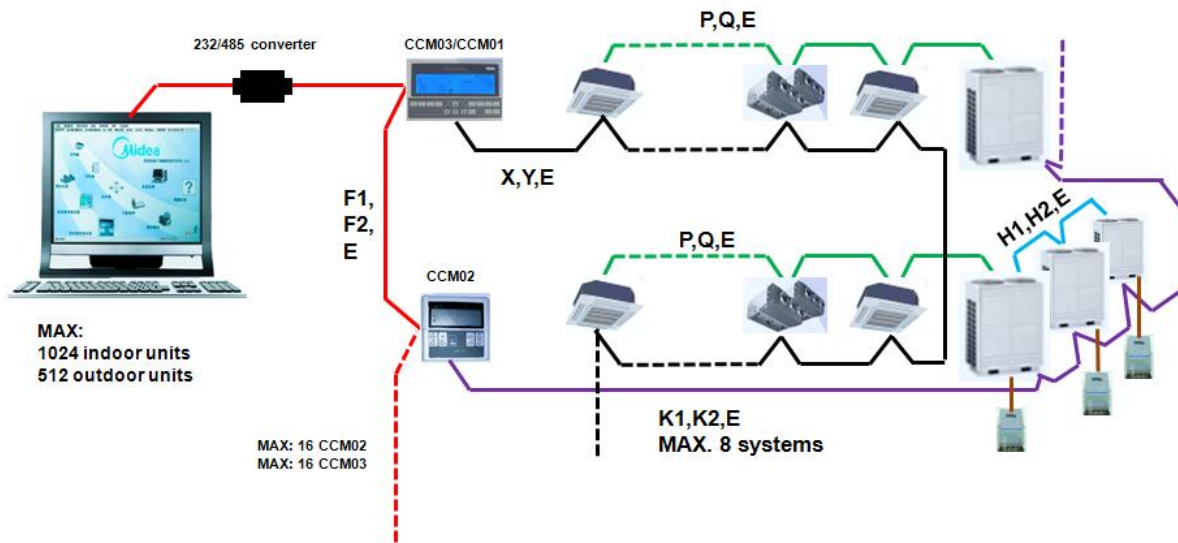

For the 2nd type of network topology, either of the connection below is available:

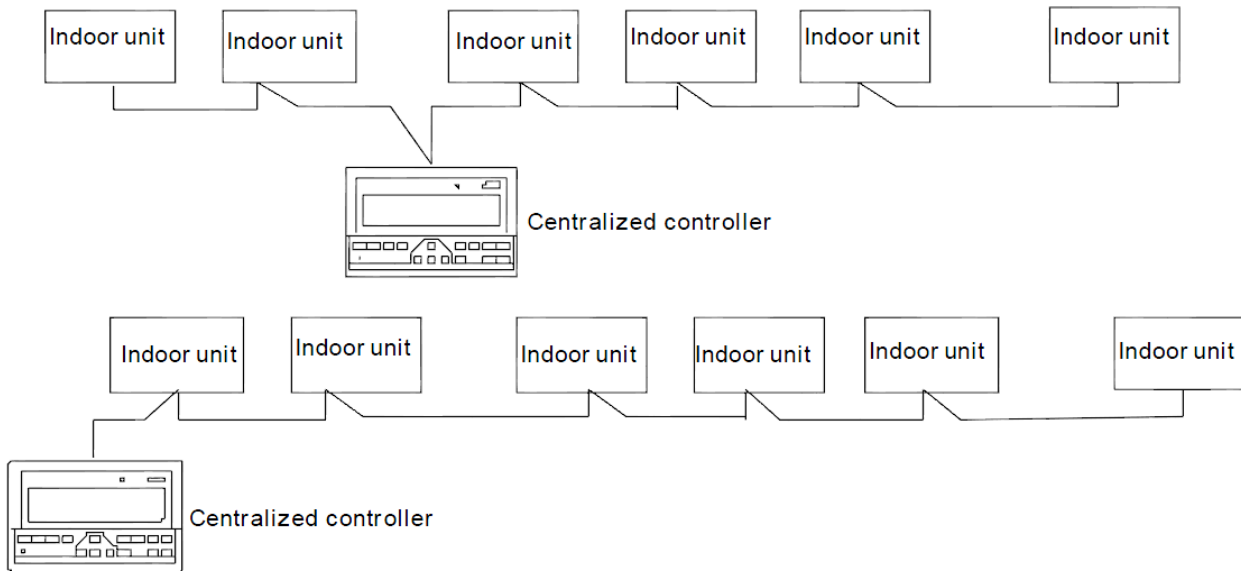

To establish a steady network the following should be noted

- The signal wire should be 3-core shielded wire and the wire should be provided by licensed electricians.
- To make signal transmission steady and to protect the facilities, the signal transmission wires should not be near to the power line. An interval of 300mm-500mm should exist between these two kinds of wires.
- The signal wire of each network should be less than 1,200m.
- The unit and the centralized controller should be connected hand-in-hand, which means that all the units' same port should be connected to a 3-core wire and the signal wire should be linear in topology. Or else, the facilities could not work normally.

2.4.1.2 Description Names and Functions

Keywords and general function description

1 Power on or reset

When the centralized controller is powered on or reset, all display segments of the LCD are luminous for 2 seconds and then goes off. 1 second later, the system enters the normal display status. The centralized controller is in the main page display status and displays the first page, and searches the in-service air conditioners in the network. Once the search is finished, the centralized controller enters the mode setting page, and sets the first in-service air conditioner by default.

2 Network area address of centralized controller

The local computer or gateway can be connected with 16 centralized controllers for communication. Each centralized controller serves as an area of the air conditioner network. The centralized controllers are differentiated by bit selection address. The configurable range is 0~15.

3 State indications

If any local keypad operation is setting the operation status of the air conditioner, the indicator is on when the signals are sent. Upon completion of the setting process, the indicator goes off. If an in-service air conditioner in the network is faulty, or the centralized controller network itself is faulty, the indicator will blink at 2Hz.

If one or more in-service air conditioners in the network are running, including under setting of timing

start/shutdown, the indicator will be luminous. Otherwise, the indicator is off.

4 Locking of centralized controller

After receiving the centralized controller locking command sent from the computer, the centralized controller disables the startup/shutdown and setting of the air conditioner, and sends commands to lock remote controllers of all air conditioners in the network of the centralized controller. After receiving the unlocking command, the centralized controller enables the startup/shutdown operation, and sends commands to unlock the remote controller of all air conditioners.

The locking status of the remote controller can be locked or unlocked by the computer or centralized controller separately. The locking status of the centralized controller is memorized after power failure of the centralized controller, and will not vanish after the power supply is restored, unless the command of unlocking is received.

5 Mode locking function

After the mode locking command is received, the command is forwarded to the air conditioner, and the centralized controller displays the mode locking flag. After the command of unlocking is received, the non-conflict mode can be selected freely. The centralized controller can also lock modes of all indoor units.

6 Emergent shutdown and compulsory startup

When the emergent shutdown switch of the centralized controller is shorted, all air conditioners in the network of the centralized controller will shut down compulsorily. The centralized controller and computer and all functional modules are disabled from startup and shutdown until the foregoing switch is open. When the compulsory startup switch of the centralized controller is shorted, all air conditioners in the network of the centralized controller will start up compulsorily. In default conditions, they will run in the cooling mode. The startup and shutdown operations of the centralized controller and the computer and all functional modules will be disabled (only the command of startup is sent to the air conditioner, without affecting operation of the remote controller after startup) until the foregoing switch is opened.

If the foregoing two switches are shorted in the same time, the emergent shutdown switch shall have preference.

Liquid Crystal Display:

Full display of LCD

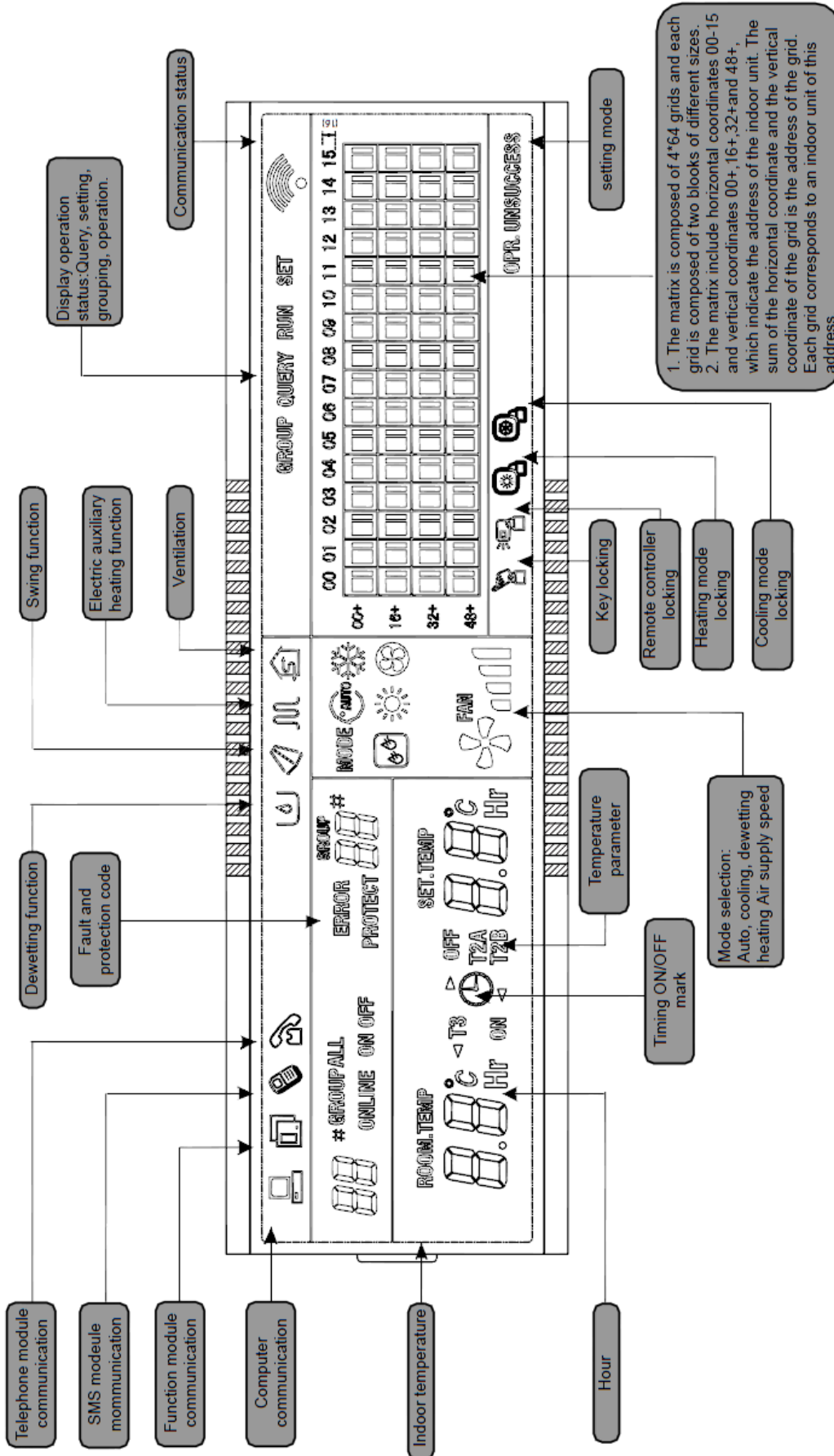

Note:

Each grid composes two blocks, whose sizes are different and indicates different status. Indications are as General Information

follows:

status \ Object	Constantly on	Slow blink	Fast blink	Disappeared
Big block	Unit is in service	Selected		Out of service
Small block	Power is on		Unit malfunction	Power is off

Buttons and Functions

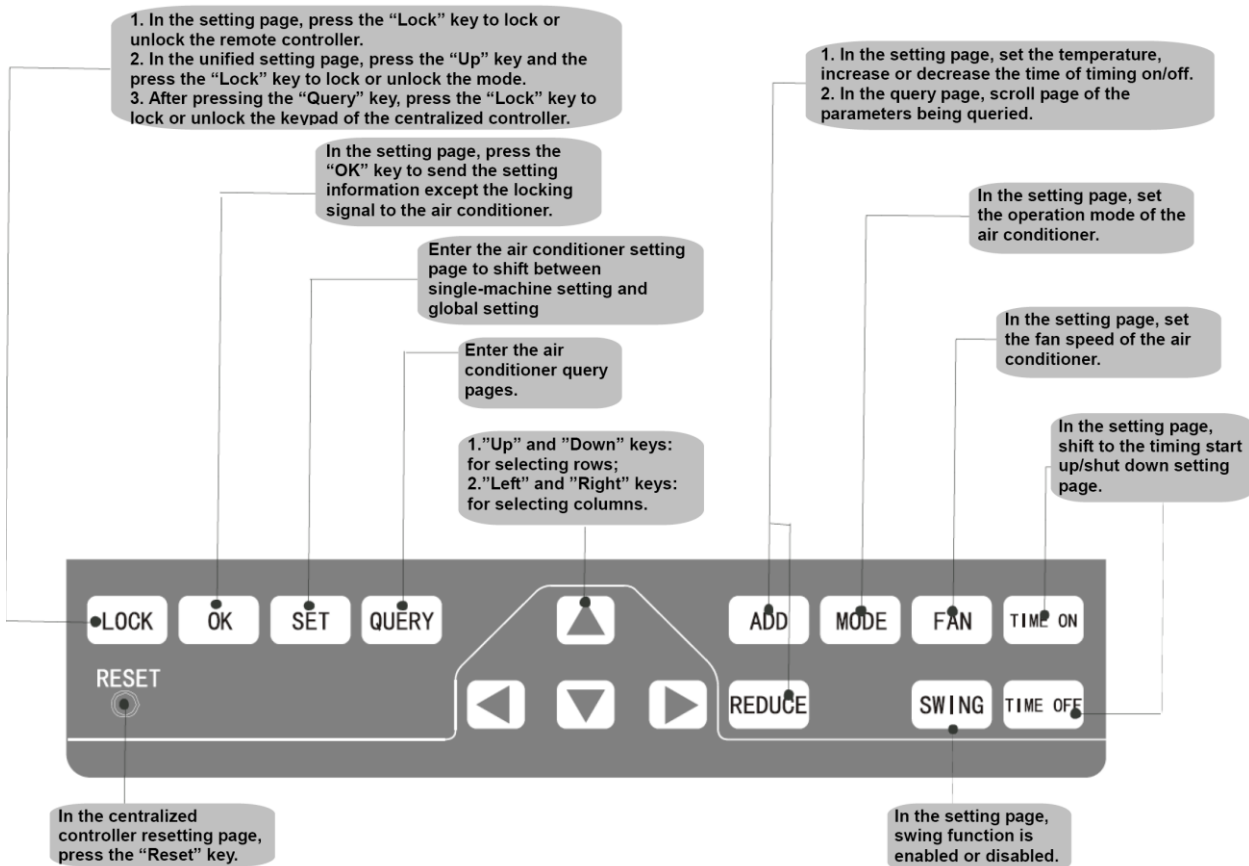

1) Query key

Any time when you press the key, the selected operation mode is to query the operation status of the air conditioner. By default, the first in-service air conditioner will be queried. Through the Increase and Decrease keys, you can change the parameter page to be queried; through the Up, Down, Left and Right keys, you can change to query status of other in-service air conditioners.

2) Set key

In other display mode, press the key to enter the setting mode. By default, it is single setting, and the first in-service air conditioner is displayed. In setting operation mode, press the key again, and the operation will be performed for all air conditioners in the network. Press the key repeatedly to shift between single setting and global setting.

→ Single → Global →

3) Mode key

In setting operation mode, press this key to set the operation

→ cooling → heating → supply air only → stop →

In other display mode, press the key to enter the setting mode. By default, it is single-machine setting, and the first in-service air conditioner is displayed.

4) Fan key

In setting operation mode, press this key to set the fan of the indoor unit of the air conditioner to run in the automatic, high, medium or low level of air.

→ auto → low → medium → high →

5) Time on key

In setting operation mode, press this key to set the timing startup of air conditioner; press the key again to exit the timing setting, and restore the normal temperature regulation operation mode.

→ time on → set temperature regulation →

6) Time off key

In setting operation mode, press this key to set the timing shutdown of air conditioner; press the key again to exit the timing setting, and restore the normal temperature regulation operation mode.

→ time on → set temperature regulation →

7) Swing

In setting operation mode, press this key to enable or disable the swing function. If all currently selected air conditioners have no swing function, no effect will result after pressing the key.

8) Leftward key

In the query mode, every time when you press the key, the operation status data of the previous air conditioner will be displayed. If it is currently on the first machine, press the key again, and the data of the last machine will be displayed. If you hold down this key, the address will decrease one by one.

In the setting mode, every time when you press the key, if it is in single operation mode, the air conditioner of the previous in-service address number will be selected. If it is in the global operation mode, no effect will result after the key is pressed.

In the main page, press the key to enter the query mode. By default, it is the first air conditioner in-service.

9) Rightward key

In the query mode, every time when you press the key, the operation status data of the last air conditioner will be displayed. If it is currently on the last machine, press the key, and the data of the first machine will be displayed. If you hold down this key, the address will increase one by one.

In the setting mode, every time when you press the key, if it is in the single operation mode, the air conditioner of the next in-service address number will be selected. If it is in the global operation mode, no effect will result after the key is pressed.

In the main page, press the key to enter the query mode. By default, it is the first in-service air conditioner.

10) Downward key

In the query mode, every time when you press the key, the operation status data of the air conditioner corresponding to the next row of the matrix will be displayed. If it is currently in the last row, press the key, and the data of the air conditioner corresponding to the first row will be displayed. If you hold down this key, the row will increase one by one.

In the setting mode, every time when you press the key, if it is in the single operation mode, the air conditioner corresponding to the last row will be selected. If it is in the global operation mode, no effect will

result after the key is pressed.

In the main page, press the key to enter the query mode. By default, it is the first in-service air conditioner.

11) Upward key

In the query mode, every time when you press the key, the operation status data of the air conditioner corresponding to the previous row of the matrix will be displayed. If it is currently in the first row, press the key, and the data of the air conditioner corresponding to the last row will be displayed. If you hold down this key, the row will decrease one by one. In the setting mode, every time when you press the key, if it is in the single operation mode, the air conditioner corresponding to the previous row will be selected. If it is in the global operation mode, no effect will result after the key is pressed.

In the main page, press the key to enter the query mode. By default, it is the first in-service air conditioner.

12) Add key

In the main page or the query mode, every time when you press the key, the data of the last page will be displayed. If it is now in the last page, press the key again, and the first page will be displayed.

In the setting mode, every time when you press the key, if it is in the temperature regulation mode, the set temperature will decrease by 1 °C until the highest allowed set temperature; if it is in the timing startup/shutdown time setting mode, select the upper-level set time, if no time is set, 0.0 will be displayed, if you hold down the key, the upper-level data will be selected consecutively.

The specific change mode is as follows:

0.0→0.5→1.0→1.5→2.0→2.5→3.0→3.5→4.0→4.5→5.0→5.5→6.0→6.5→7.0→7.5→ 8.0→8.5→9.0→
9.5→10→11→12→13→14→15→16→17→18→19→20→21→22→23→24

13) Reduce key

In the main page or the query mode, every time when you press this key, the data of the current page will be displayed. If it is now in the first page, press the key again, and the last page will be displayed.

In the setting mode, every time when you press the key, if it is in the temperature regulation mode, the set temperature will decrease by 1 degree until the lowest allowed set temperature; if it is in the timing startup/shutdown time setting mode, select the upper-level set time, if no time is set, 0.0 will be displayed, if you hold down the key, the upper-level data will be selected consecutively.

The specific change mode is as follows:

0.0← .5←1.0←1.5←2.0←2.5←3.0←3.5←4.0←4.5←5.0←5.5←6.0←6.5←7.0←7.5←8.0←8.5 ←9.0←
9.5←10←11←12←13←14←15←16←17←18←19←20←21←22←23←24

14) ON/OFF key

Any time when you press the key, the centralized startup/shutdown operation is performed for all current in-service air conditioners in the centralized controller network. If all in-service air conditioners in the network are in the power-off status, press the key to perform the startup operation.

If it is in the mode setting page currently, and the parameters such as startup mode, temperature and air speed are selected, the air conditioner will be started according to the selected parameters.

If no mode is selected currently, and the air conditioner is powered off or it is in other display page currently, and the default startup mode is: Cooling, strong air, set temperature 24°C, swing function enabled. The default startup mode is locked according to the system mode or judged according to other constraint conditions. If any conflict exists, the next conflict-free mode will apply automatically. If conflict exists for all modes, startup will be impossible. If one or more in-service air conditioners in the network (including in the timing process of timing startup/shutdown), pressing this key will shut down all air conditioners. When performing the shutdown operation, the shutdown command is issued to the air conditioners in the startup status only, and is not issued to those in the shutdown status.

15) Lock key

In the mode setting mode, press the Lock key, and the remote controller of the currently selected air conditioner will be locked/unlocked. The operation mode is: If you select single-machine setting, the operation is performed for the air conditioner of the current address only. If the remote controller of the air conditioner is locked currently, issue the lock command; otherwise, send the lock command. If you does not select the single-machine mode, and the remote controller of one or more currently selected air conditioners is locked, issue the unlock command; if the remote controllers of all currently selected air conditioners are in the non-locked status, issue the remote controller lock command. When the remote controller of the air conditioner is locked, the air conditioner does not receive remote control signals from the remote controller or wire controller until the remote controller is unlocked. Press the Query key and then press the Lock key, and the keys of the centralized controller will be locked or unlocked. If the keys are currently locked, press the foregoing keys concurrently again, and the keys will be unlocked; if the keys are currently unlocked, press the foregoing keys concurrently, and the keys will be locked. If the keys are locked, pressing of any key other than the Unlock key will be ineffective.

In the unified setting page, press the Up key and the Lock key concurrently to lock all air conditioner mode in the network. The mode locking is cancelled when the key is pressed again.

Note:

When you lock or cancel locking, the corresponding icon indication appears or disappears only after all the air conditioners in-service are set completely, as a result, it take a while to finish the mission. When the air conditioners in-service is many, wait patiently.

16) Confirmation key

In the setting mode, press the key to send the currently selected mode status and the auxiliary function status to the selected air conditioner, and display the mode setting operation results.

After you select the operation mode and auxiliary function status information of the air conditioner, if you do not press the confirmation key, the selected information will not be sent to the air conditioner, and will not affect the current operation of the air conditioner.

The operations of remote controller locking and unlocking do not need pressing the confirmation key. The command information is sent directly after the locking key is pressed.

17) Reset key

Anytime when the reset key is pressed, the centralized controller will reset. The result is the same as the result of restoring power-on after power failure.

2.4.1.3 Installation

Installation dimensions:
As shown in the figure
on the right side.

Installation screw
holes (4 holes)

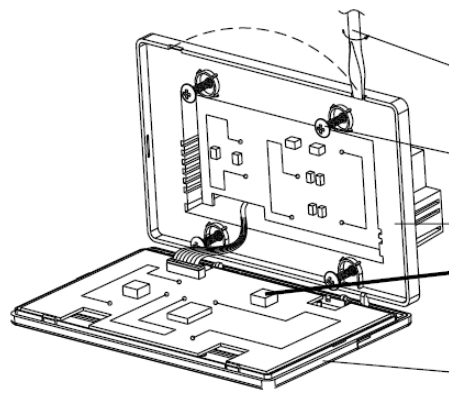
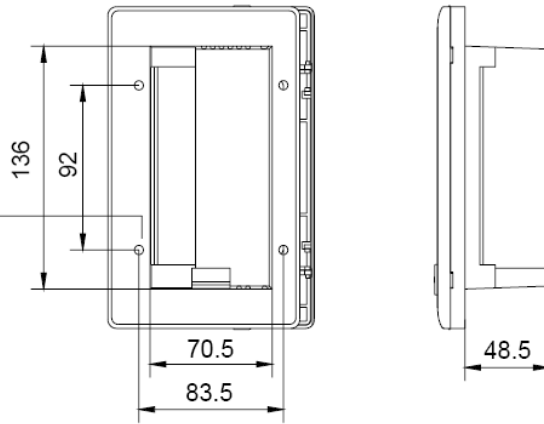

Rotate the flathead screwdriver slightly
to open the upper cover (at points).

Screws for fixing the centralized
controller (GB845/ST3.9*25)

Holder
Address
bits



Upper
cover

Bit location	Address range
~	00 ~ 15

Note: To differentiate each centralized controller, the controllers in the same RS-485 net should be with different address with each other.

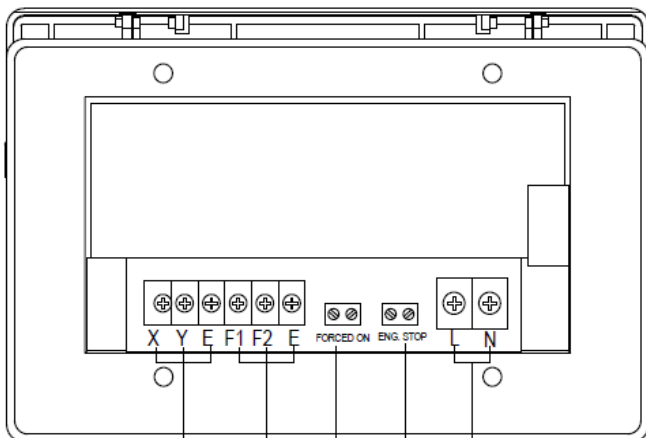

Emergent start switch
Emergent stop switch
Power cable interface of centralized controller (198V~242V) / (50 / 60HZ)
Communication interface with computer
Communication interface with indoor interface

RS232 Pin hole: for connection to computer COM port

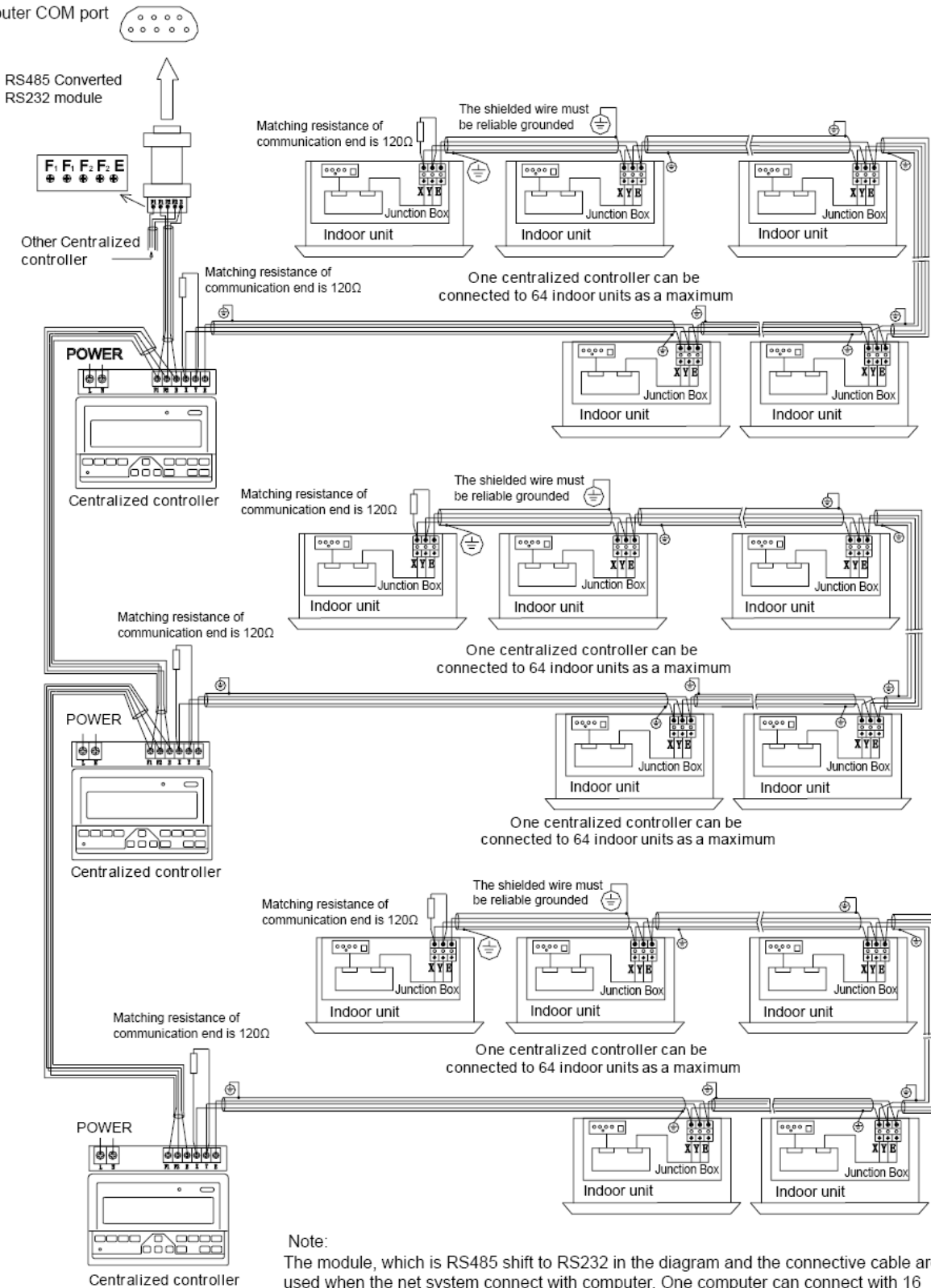

Note:

The module, which is RS485 shift to RS232 in the diagram and the connective cable are only used when the net system connect with computer. One computer can connect with 16 centralize controllers, namely 16X64=1024 indoor units could be controlled at mostly. The centralize controller to be distinguished by dial code address, the address setting range is from 0 to 15, thus in a network system without two centralize controller could be set in a same address.

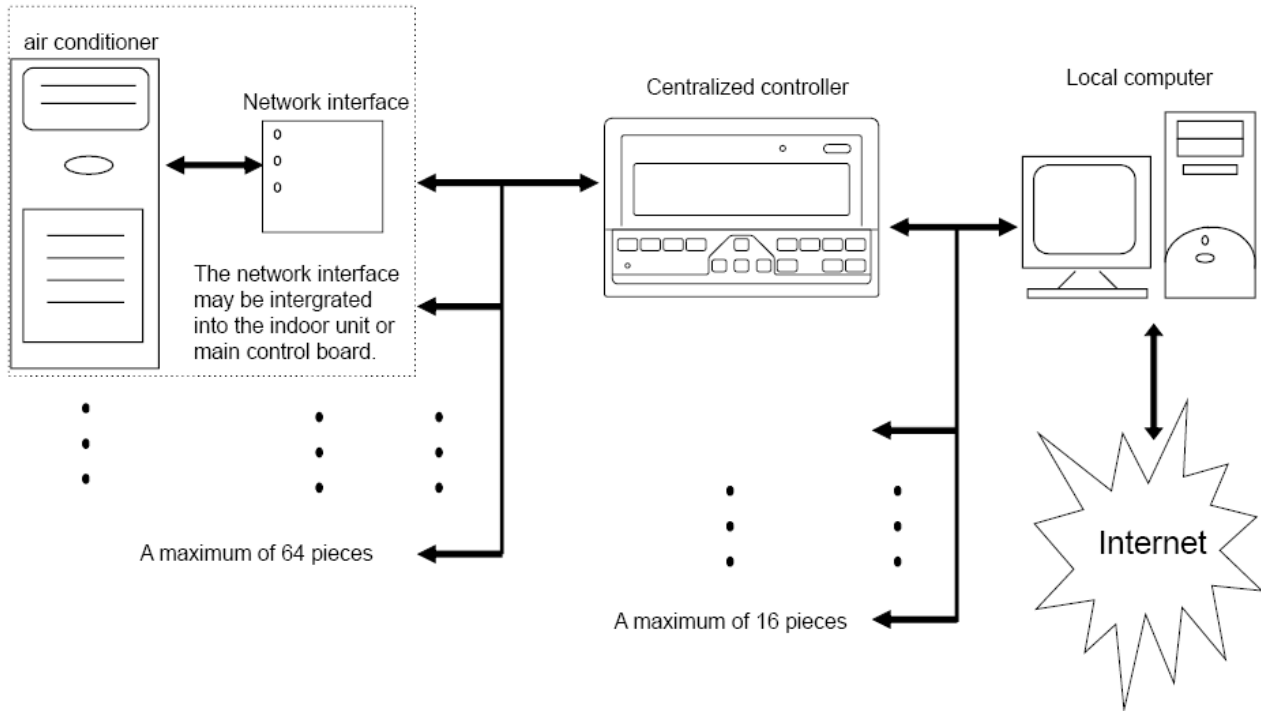

Before starting the net work, please confirm that every CCM03's address is different with each other.

2.4.1.4 Query and Error code

The CCM03 centralized controller offers the function of query of indoor units' running state and displays the error code when some of the indoor units fail down.

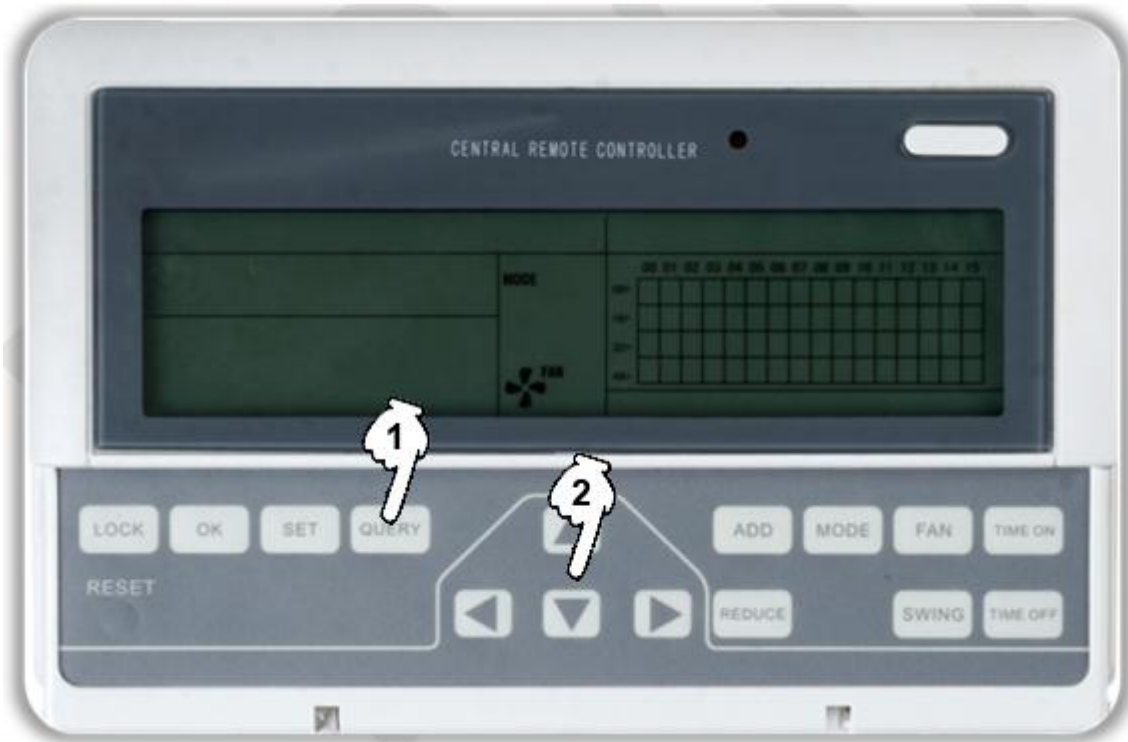

1. Press the query button to activate the query function. Firstly the display panel will display the 1st units' state.
2. Use the UP, DOWN, LEFT, RIGHT buttons to select the unit we want to query.

The indication of error codes are as the 2 tables below:

Fault code	Content
EF	Other faults
EE	Water level detection faults
ED	Outdoor unit fault
EC	Cleaning fault
EB	Inverter module protection
EA	Current of compressor is too large (4 Times)
E9	Fault of communication between main board and display board
E8	Wind blowing speed is out of control
E7	EEPROM error
E6	Detection of current direction alternating is abnormal
E5	T3 or T4 temp. sensor of discharge of compressor fails down
E4	T2B sensor fails to work normally
E3	T2A sensor fails to work normally
E2	T1 sensor fails to work normally
E1	Communication fault
E0	Phase sequence disorder or loss of power phase
07#	
06#	
05#	
04#	
03#	Communication mistake between centralized controller and PC(gateway)
02#	Communication mistake between centralized controller and functional module
01#	Communication mistake between centralized controller and network interface module
00#	Communication mistake between network interface module and main control board

Protection code	Content
PF	Other protection
PE	Reserved
PD	Reserved
PC	Reserved
PB	Reserved
PA	Reserved
P9	Reserved
P8	Compressor's current is too large
P7	Voltage of power supply is too high or too low
P6	Pressure of discharge is too low
P5	Pressure of discharge is too high
P4	Temp. of discharge pipe is abnormal

P3	Temp. of compressor is abnormal
P2	Condenser high-temperature protection
P1	Anti cool air or defrost protection
P0	Evaporator temperature protection

5. Make sure there is no joint in the middle of the shielded cable. If such a joint exists, use a socket to connect it.

2.4.5 Central control monitor MD-CCM02/E

MD-CCM02/E is a control monitoring device used to monitoring the outdoor units’ status. Moreover, MD-CCM02 is able to bridge the outdoor units to the gateway, and then realize the BMS monitoring, which makes the building management visible and one-station.



- RS485 communication protocol
- Up to 8 systems, max.32 outdoor units can be centralized monitor
- It can display the operating parameter of outdoor units
- It can display the error or protection code of outdoor units

2.4.4.1 System configure

With MD-CCM02/E, we could both centrally display the outdoor units’ running status and bridge up to 32 outdoor units to the PC monitoring software or BMS--Building Management System. In fact, for the purpose of connecting the indoor units to the PC or the gateway, which makes the outdoor units visible on the display panel, MD-CCM02/E is necessary.

The location of CCM02 in the network is as follows.

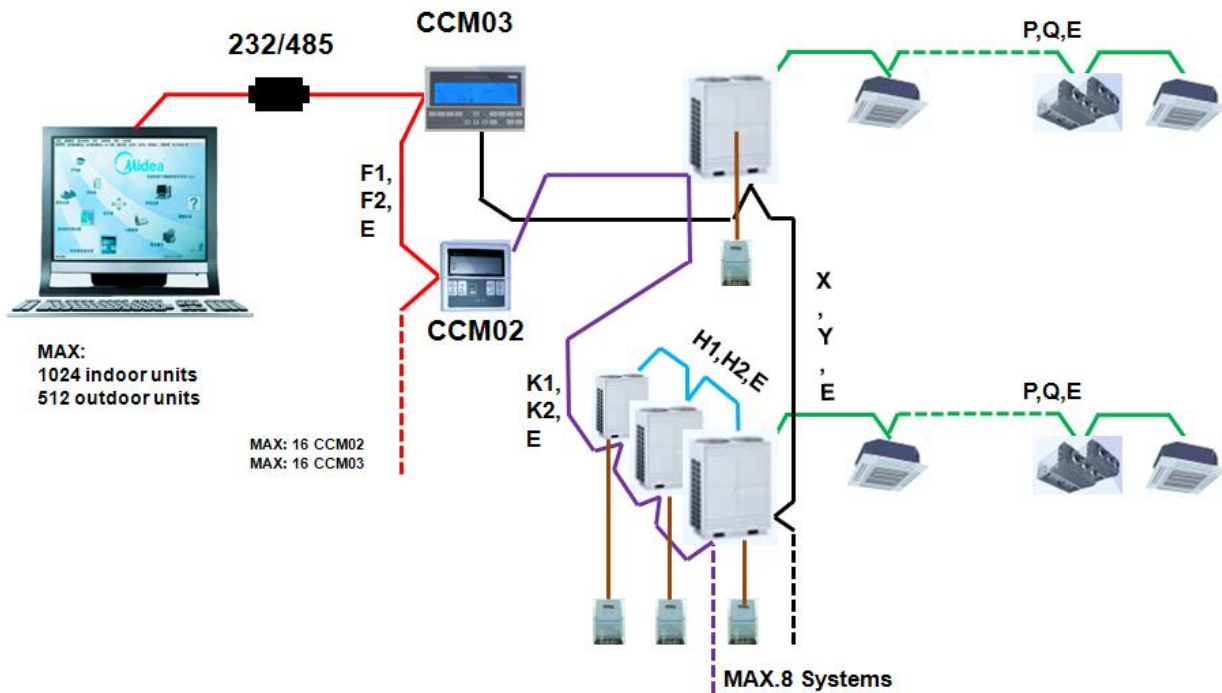

To establish a steady network the following should be noted

- The signal wire should be 3-core shielded wire and the wire should be provided by licensed electricians.
- To make signal transmission steady and to protect the facilities, the signal transmission wires should not be near to the power line. An interval of 300mm-500mm should exist between these two kinds of wires.
- The signal wire of each network should be less than 1,200m.
- The unit and the centralized controller should be connected hand-in-hand, which means that all the units' same port should be connected to a 3-core wire and the signal wire should be linear in topology. Or else, the facilities could not work normally.

2.4.5.1 Description of Names and Functions

Key Words and Basic Functions

After the CCM is power on or reset, all the segments on LCD will be displayed and last for 3 seconds. And then disappear for 2 seconds. After this, the controller's system runs at normal display mode, in which CCM would display the main page.

Network Area Address Setting

Up to 16 CCM02 can be connected to the gateway or the PC. Each CCM02 can be view as a secondary or sub-net of the network and distinguish themselves by their unique address. The address can be set in the key panel and it ranges from 16-31.

Address setting method:

To differentiate the CCM02 and CCM03, the addresses of CCM02 range from 16-31. Every time we press the address button of a CCM02, the corresponding CCM02's address increase by 1. When the address come to the end 31, press the key again could make the address back to the starting address 16.

Indicator Display

Indicator light will be on when the CCM02 is powered on.

General Information

CCM02 LOCKED

Press this button to start the lock mode. In lock mode, all the buttons cannot lock, except the LOCK button. Press LOCK button again to cancel this mode.

Electricity consumption query

CCM02 allows user check each outdoor units' electricity consumption. To realize this function, each outdoor unit should be installed with an ammeter. The ammeter DTS634/DT636 can be purchased from Midea Company.

Buttons and Functions

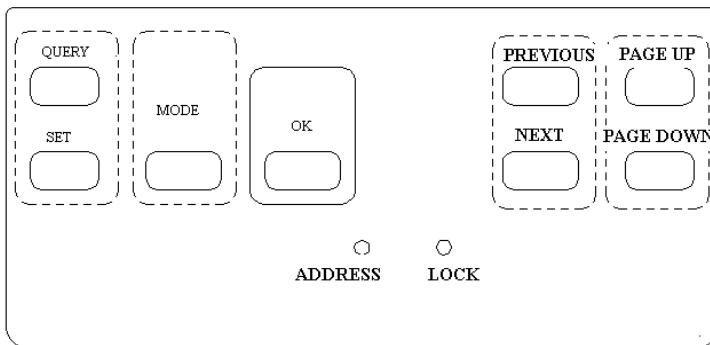

- 1) **QUERY**: Push it to enter into the query state
- 2) **PREVIOUS**: On the query state, press it to query in default the running status of a previous online air conditioner.
- 3) **NEXT**: On the query state, press it to query in default the running status of a previous online air conditioner.
- 4) **PAGE UP**: Press the PAGE UP button when choosing an online air conditioner on the query mode to display the parameters in previous page.
- 5) **PAGE DOWN**: Press the PAGE DOWN button when choosing an online air conditioner on the query mode to display the parameters in next page.
- 6) **SET**: Press SET button to enter into Set Page.
- 7) **MODE**: Pressing MODE button to enter into MODE setting function. Users can set the indoor unit to the Force Cool mode or OFF mode.
- 8) **OK**: Pressing OK button to confirm all settings and send the setting signals to the corresponding air-conditioners.
- 9) **LOCK**: Press this button to disable other buttons and prevent users from pressing the other button neglectfully. Press this button again to quit the lock status.
- 10) **ADDRESS**: In set page, pressing the SET button repeatedly, the address number will be increased by one. When the address is equal 31 and you press once more, the address will restart from 16.

Description of LCD Screen

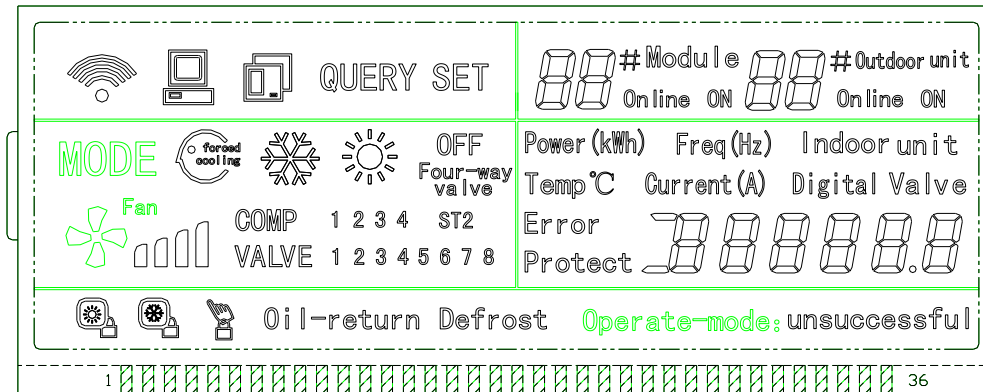

Data Delivering

1. Figure means CCM is sending query order;
2. Figure means CCM is in communication connection with PC, and it will be off in 20 seconds with no communication;
3. Figure means CCM is in communication connection with outdoor unit, and it will be off in 20 seconds with no communication
- 4 Press the OK button in setting page and waiting for 4 seconds, "successful" or "unsuccessful" will be shown in the operation state area.

Stand-by Page Display:

1. Figure means the total number of online modules;
2. Figure means the total number of online outdoor units;
3. Stand-by Page can display the address of CCM with the address format of "Addr xx" here "xx" equals the real address of CCM plus 16 so the range of "xx" is 16-31.

Query Page Display:

1. Query Page Display the symbol of query.
2. Displaying the selected outdoor unit with address of and .
3. Mode display: means cool, means heat, OFF means shut off, means cooling mode only, means heating mode only.
4. Fan Speed Display: means low speed, means middle speed, means high speed.
5. Compressor State Display "COMP. 1 2 3 4".
6. Electromagnetism Valve Display "EMV. 1 2 3 4 5 6".
7. 4-Ways Valve Display: St2 .
8. Defrost Display "Defrost".
9. Oil Return Display "OIL RETURN".
10. Page 0 displays the consumption of electric energy with: "ELECTRIC ENERGY kW/h" and the number.

11. Page1 displays the input power frequency with Frequency Hz and the number.
12. Page2 displays the total number of indoor units.
13. Page3 displays the temperature symbolic T3 "TEMP. °C", "T3" and the number.
14. Page4 displays the temperature symbolic T4 "TEMP. °C", "T4" and the number.
15. Page5 displays the temperature symbolic T6 "TEMP. °C", "T6" and the number.
16. Page6 displays the discharge temperature of compressor symbolic C1with"TEMP. °C", "C1" and the number.
17. Page7 displays the discharge temperature of compressor symbolic C2 with "TEMP. °C ", "C2" and the number.
18. Page8 displays the discharge temperature of compressor symbolic C3 with "TEMP. °C ", "C3" and the number.
19. Page9 displays the compressor current symbolic 1 with"CURRENTA", "1" and the number.
20. Page10 displays the compressor current symbolic 2 with "CURRENT A", "2" and the number.
21. Page11 displays the compressor current symbolic 3 with "CURRENTA", "3" and the number.
22. Page12 displays the digital capacity with "DIGITAL CAPACITY" and the number.
23. Page13 displays the openness of electromagnetism valve symbolic 1 with "VALVE OPENNESS", "1" and the number.
24. Page14 displays the openness of electromagnetism valve symbolic 2 with "VALVE OPENNESS", "2" and the number.
25. Page15 displays the most advanced malfunction with "MALFUNCTION" and the code.
26. Page16 displays the most advanced protection with "PROTECTION" and the code.

NOTE :

The page will increase or decrease by 1 every time you press "PAGE Up" or "PAGE DOWN"
Select the online outdoor unit by push the "previous" or "next" freely.

Set Page Display:

1. Set Page Displays "set";
2. Mode display: Pressing MODE button, and select Forced Cooling or OFF mode;
3. Set page displays the addresses of selected outdoor unit and module;
4. Pressing OK button to confirm all settings and send the signals to the corresponding air conditioners.
5. "successful" or "unsuccessful" will be displayed in the display panel to show whether the signals are accepted or not.

2.4.3.3 Installation of MD-CCM02**Dimensions: 120*120*15mm**

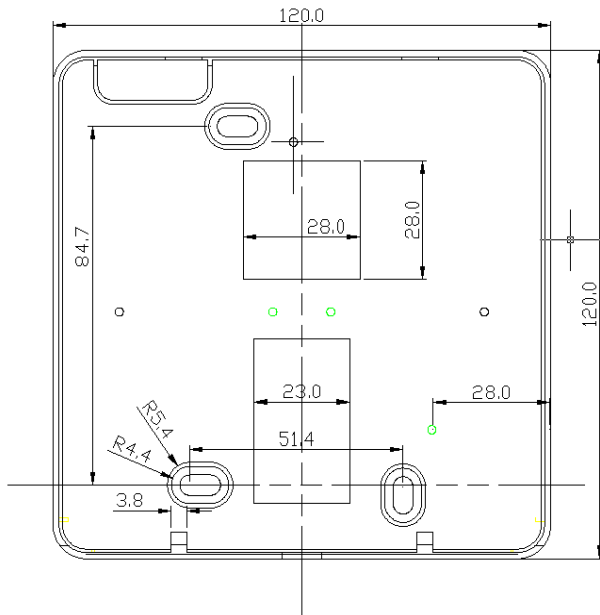

Structure and Composition

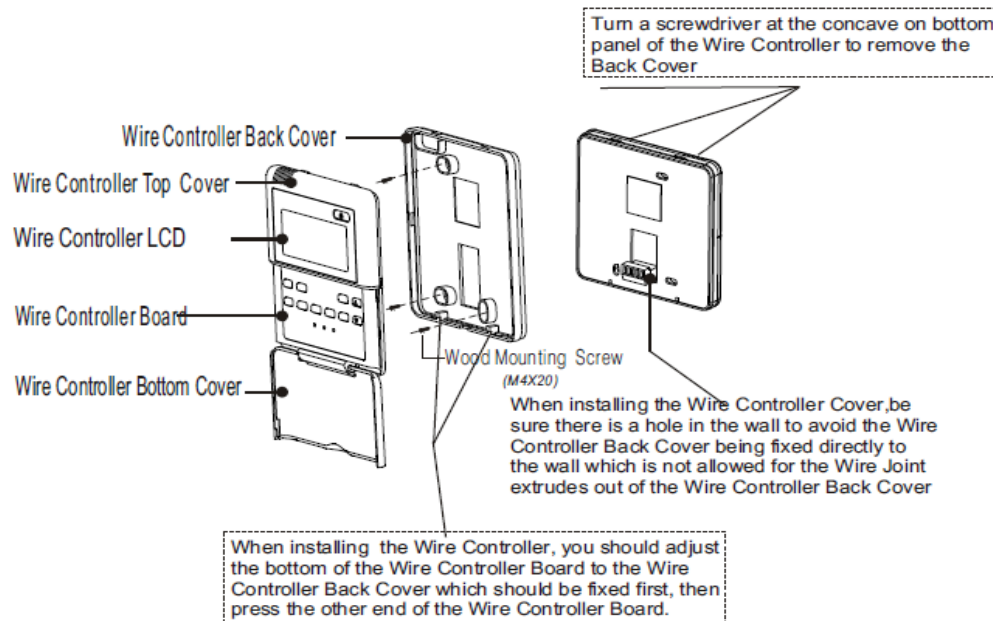

Wiring sketch map of MD-CCM02 and outdoor units

These 2 ways are both available

1st way:

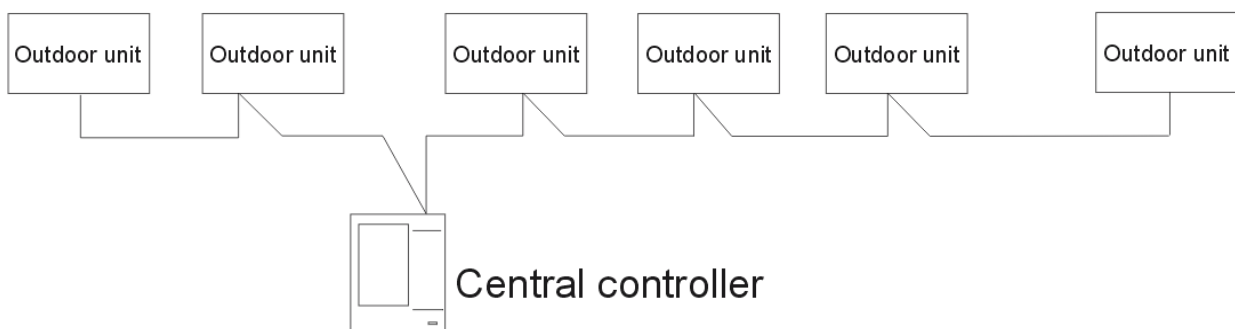

2nd way:

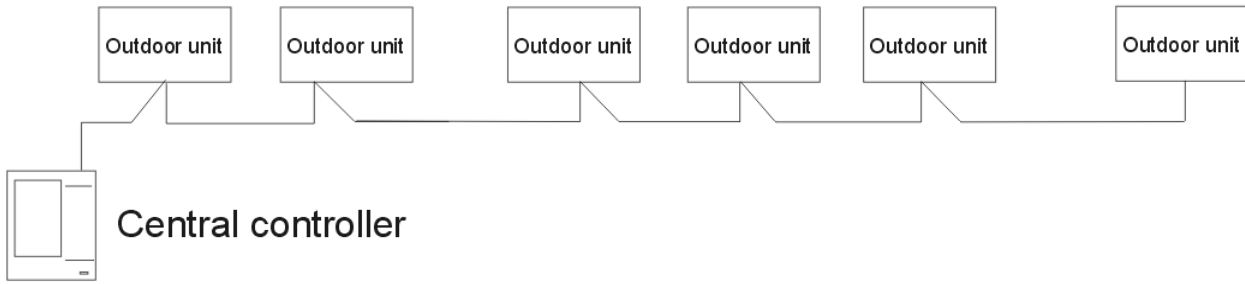

The MD-CCM02 wiring ports are as follows. F1, F2, E joints are used for PC connection. K1, K2, E joints are used for outdoor unit connections. E joint is the common terminal.

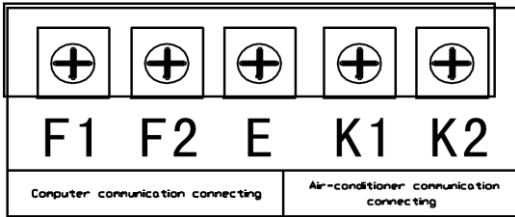

Power supply

MD-CCM02 uses a power adaptor to obtain power supply from the normal AC220V. Remember to connect the adaptor's connector.

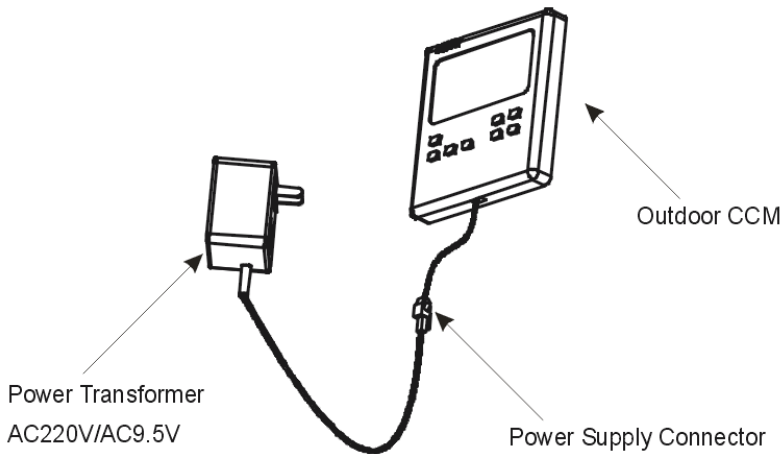

Wiring Sketch Map of Building Network Air-conditioning System

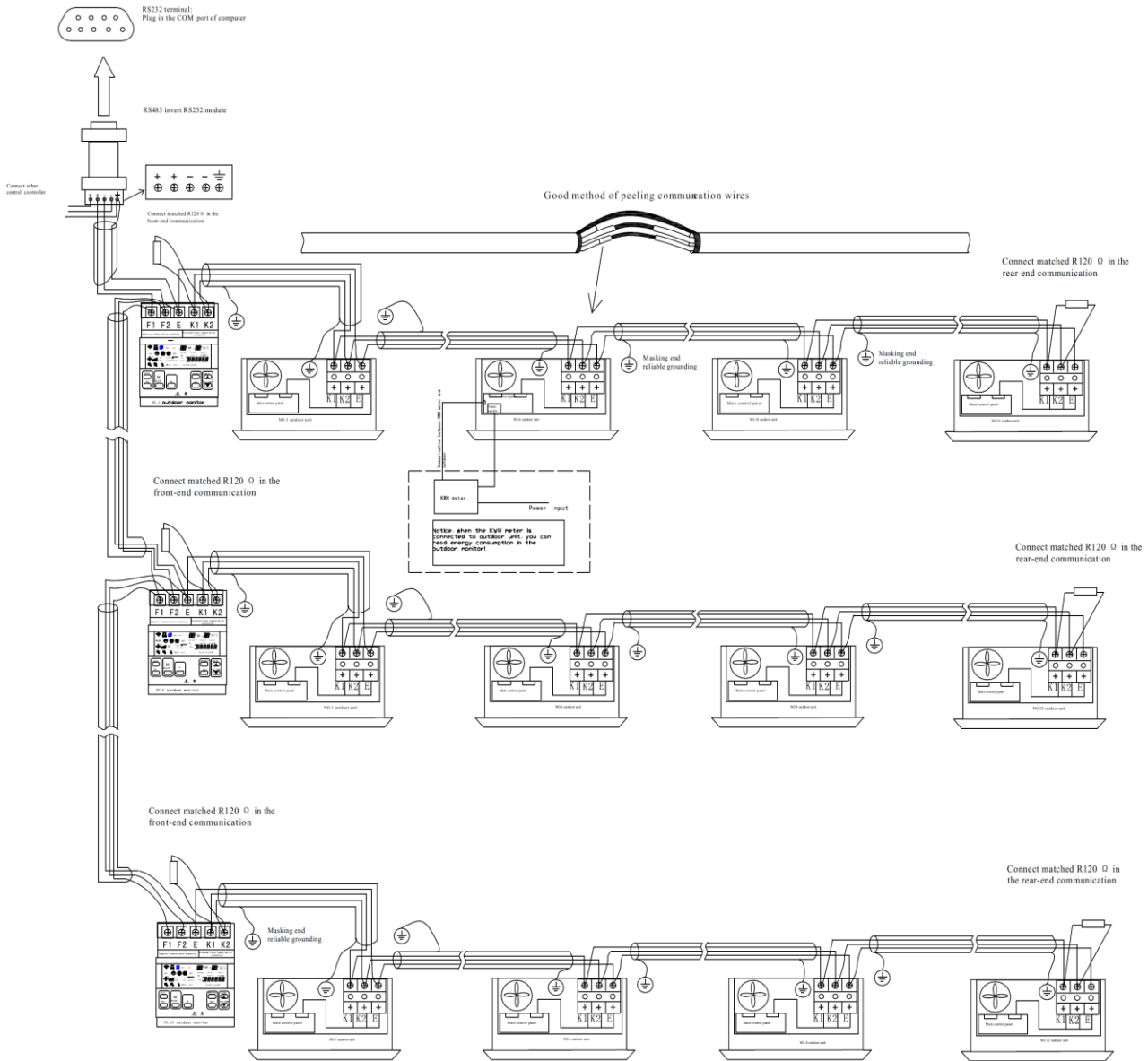

Notice

- (1) One computer can connect 16 outdoor central monitor
- (2) One outdoor central monitor can connect 8 refrigerant system
- (3) You need connect resistors 120 Ω in the start and end of each “K1, K2, E” net.
- (4) Communication wire masking end assure reliable grounding

Remarks

- (1) In the wiring, the part from Rs485 to Rs232 is only needed when connecting with PC. And one PC can connect maximum 16 outdoor MD-CCM02 and 16 indoor MD-CCM03. The addresses of MD-CCM03 ranges from 0 to 15, while the MD-CCM02 ones from 16 to 31.
- (2) One outdoor centralized monitoring MD-CCM02 can connect maximum 32 outdoor units, while one indoor MD-CCM03/E can connect maximum 64 indoor units.
- (3) The address of outdoor CCM and the address of outdoor units are set by manual. Please refer to their owner's manual for setting.

2.4.4.4 Query and error codes

Press QUERY button to start the query function. Then press the PREVOIS and NEXT buttons to select the outdoor unit that we want to check. Press the PAGE UP button 15 times to display the corresponding outdoor unit's error code or 16 times to display the protection code.

22.4.6 Mode Lock Controller KJR-31B/E

KJR-31B/E is a wired centralized mode lock controller. With this device, we could lock the mode of all the units connected to this controller to avoid mode conflict. When the mode conflict happens, e.g. some indoor units request cooling and some heating, the outdoor unit could only work in either mode. As a result, some of the indoor units could not work. By adopting this device, we could consider the environment and artificially determine whether the indoor units should work at cooling or heating mode.



- **New designed and graceful appearance**
- **Compactly functions and friendly user interface**
- **Easy networking**
- **Connected up to 64 indoor units**

2.4.6.1 System configure

Mode lock controller KJR-31B/E is only a compact indoor unit centralized controller, which cannot bridge the indoor units to the PC or BMS. Its network configuration is much the same as MD-CCM09. The following 2 ways is both available.

1st:

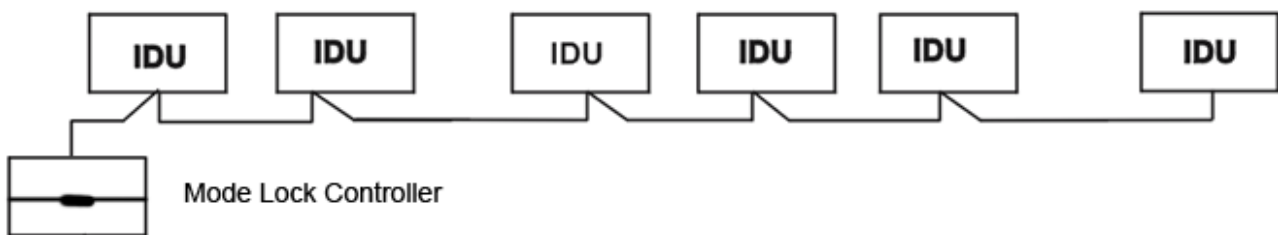

2nd:

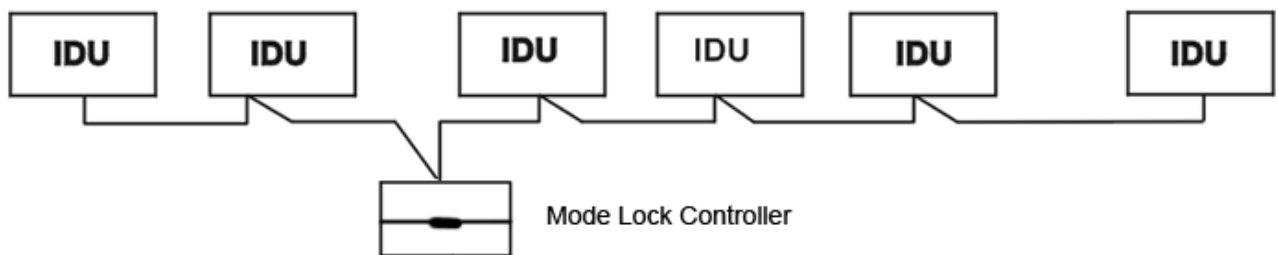

To establish a steady network the following should be noted

6. The signal cable and power cable of the central controller cannot be contained in the same cable tube. The distance between the signal cable tube and power cable tube shall be between 300mm -500mm at least.

7. The total signal cable length of the central controller shall not exceed 1,200m.

8. Make sure there is no joint in the middle of the shielded cable. If such a joint exists, use a socket to connect it.

2.4.6.2 Description Names and Functions

Buttons and indication lights

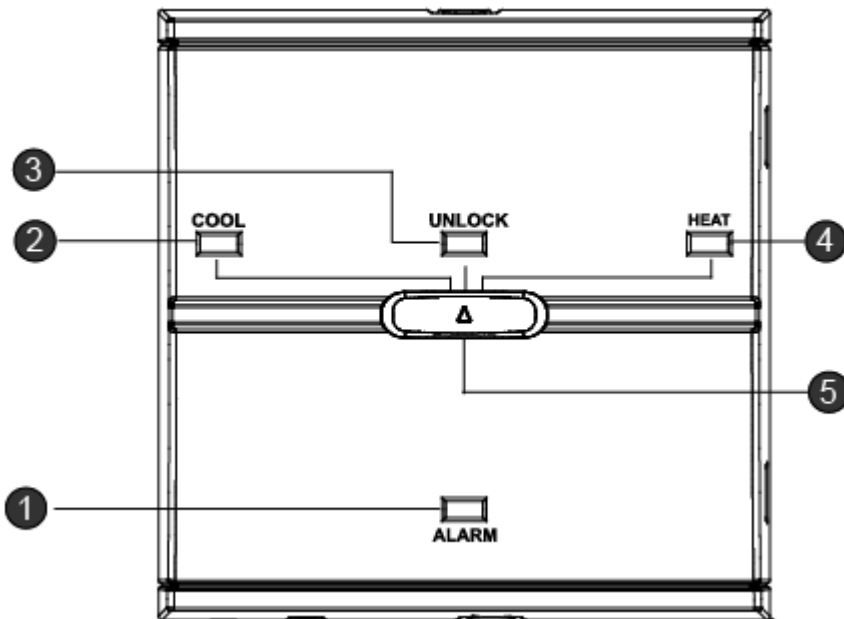

1 Alarm light

When the alarm lights are on, malfunctions occur on the indoor units. Please check the indoor unit and find the error code on the indoor unit's display panel. After solving the problem, the ALARM light will fade out.

2 COOL light

Push the mode switch leftwards to turn all the indoor units to cooling only mode and the COOL light will be on. This light indicates that all the indoor units are running at cooling mode. Users can only set the cooling parameter such as temperature and fan speed by other controller. If the user changes the units to the heating only mode, the indoor unit displays mode conflict error code. And then the corresponding unit turns off to prevent user's environment from being more unsatisfying.

3 UNLOCK light

Push the mode switch to the middle of the controller and the UNLOCK light will be on. In this mode, all the indoor units are freely to work at heating mode or cooling mode.

4 HEAT light

Push the mode switch leftwards to turn all the indoor units to heating only mode and the HEAT light will be on. This light indicates that all the indoor units are running at heating mode. Users can only set the heating parameter such as temperature and fan speed by other controller. If the user changes the units to the cooling only mode, the indoor unit displays mode conflict error code. And then the corresponding unit turns off to prevent user's environment from being more unsatisfying.

5 Mode switch

Mode switch is the only key on the controller. Slide this key and command all the indoor units to the corresponding mode to avoid mode conflict.

2.4.6.3 Installation

Dimension

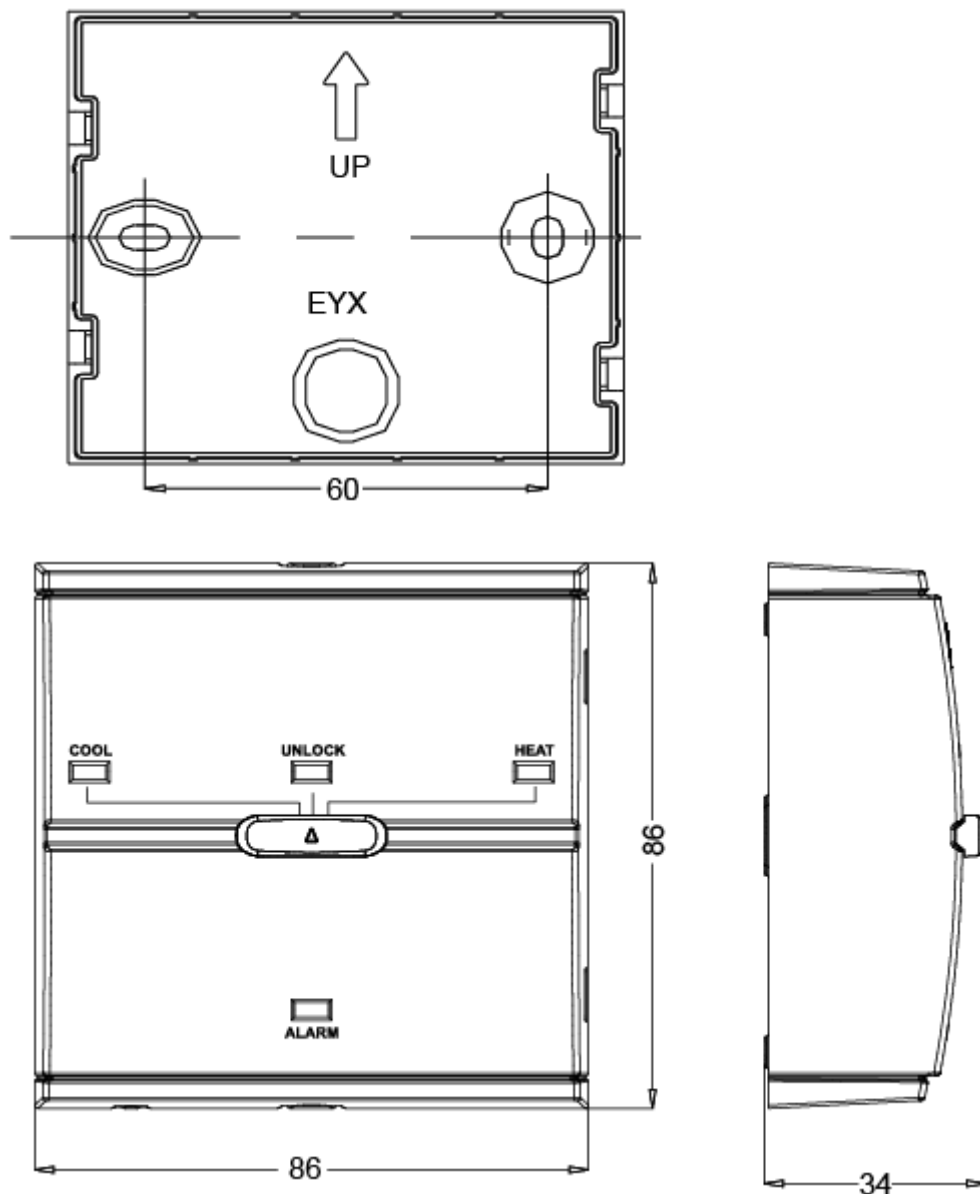

Controlling wiring connection

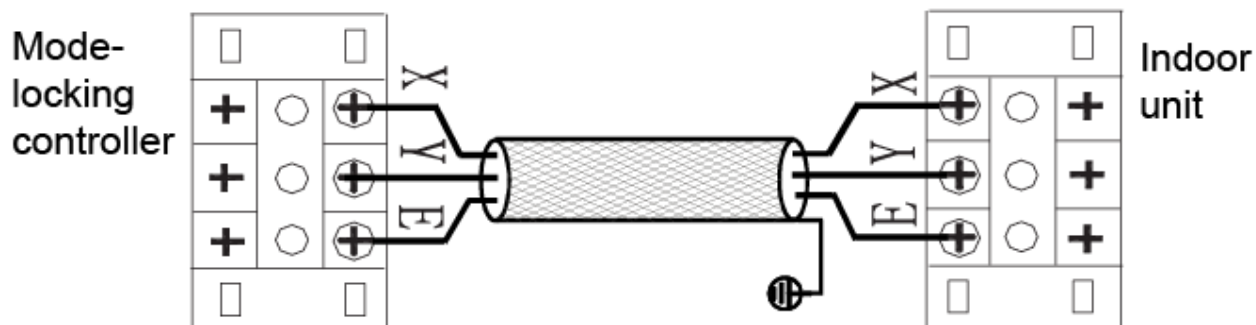

Tie the screw

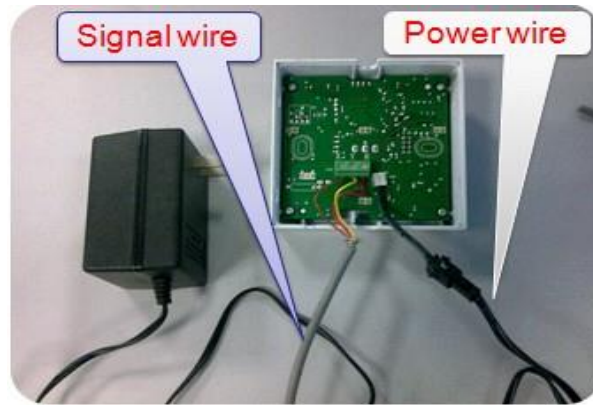
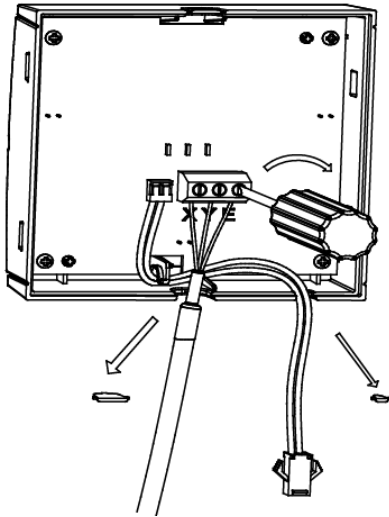

Assemble the front shell to the base

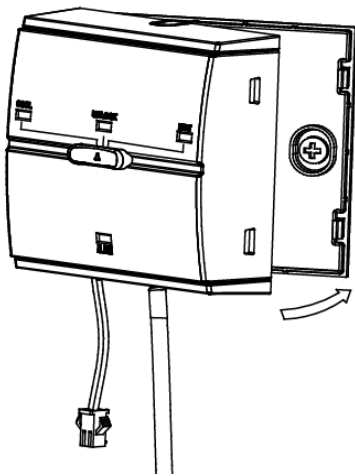

Connect the power adaptor to the controller

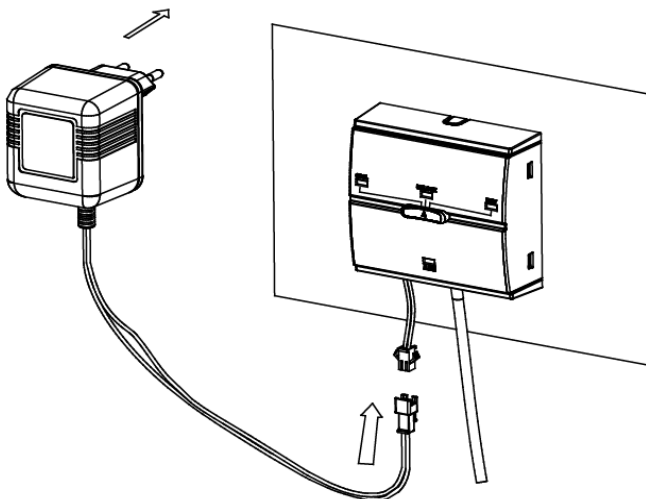

The power supply of the KJR-31B/E should be 220-240V 56/60Hz.

Summary:**Comparison of the centralized controller**

	CCM03				KJR-31B	CCM02
Time display	—				—	—
Keyboard locking	●				—	●
Querying	●				—	●
Swinging	●				—	—
Error code display	●				—	●
Error code light	—				—	—
Backlight	●				—	—
Schedule	—				—	—
FOLLOW ME	—				—	—
Fan control	●				—	—
Mode selection	●				●	—
Auto-start	●				—	—
Mode lock	●				●	—
Address equipped	●				—	●
Bride to gateway	●				—	●
Max. units	64				64	32

Note: RS-485 is the very communicative way that our units use. In one complete system, several RS-485 networks are built in side. For example, all the P, Q, E terminals compose a RS-485 network, and all the X, Y, E another. So is the K1, K2, E, and the F1, F2, E ones. Each RS-485 network should be connected in the hand-in-hand way. But the different RS-485 networks are separate.

2.5 Network Control System

Controller	Model	Description
Building gateway	MD-CCM08/E	Building gateway connects to BACnet network for integrating to other BMS to realize air-conditioning management and control. It needn't match Midea network system and PC.
Building gateway	MD-CCM07/E	Connect VRV to your BMS via LonWorks, Other systems such as those for fire and crime prevention can be easily interlocked with Midea's unit.
Network control software	MDV-WLJKXT/E(V3.1)(Firebird)	The 3 rd generation network control software with Firebird data. Add network fee charge function and connect the outdoor unit CCM based on the No.2 generation network central control system. It may connect to 16 indoor unit CCM and 1024 indoor units, and also connect to 16 outdoor unit CCM and 128 refrigeration systems.

2.5.1 Building gateway MD-CCM08/E

MD-CCM08/E is a gateway to connect the indoor units and outdoor units to the BACnet. BACnet stands for the Building Automation and Control Net work. MD-CCM08/E gathers the information of the IDU and ODU. Besides, MD-CCM08/E is able to send the command to the units.



- **Be able to bridge the indoor and outdoor units to the BACnet protocol BMS.**
- **Also be able to connect the indoor and outdoor units only, without the BMS.**
- **Contains 4 Groups of RS485 communication ports and able to connect up to 256 indoor units or 128 outdoor units instead.**
- **User can check the units' status and change their settings via local network.**
- **Compatible with Firebird.**

2.5.1.1 System configure

MD-CCM08 is able to connect up to 4 groups of RS-485 communicative network. Each of the RS-485 networks contains up to 64 indoor units or up to 32 outdoor units. The input of MD-CCM08/E should be directly connected to the CCM02 or CCM03.

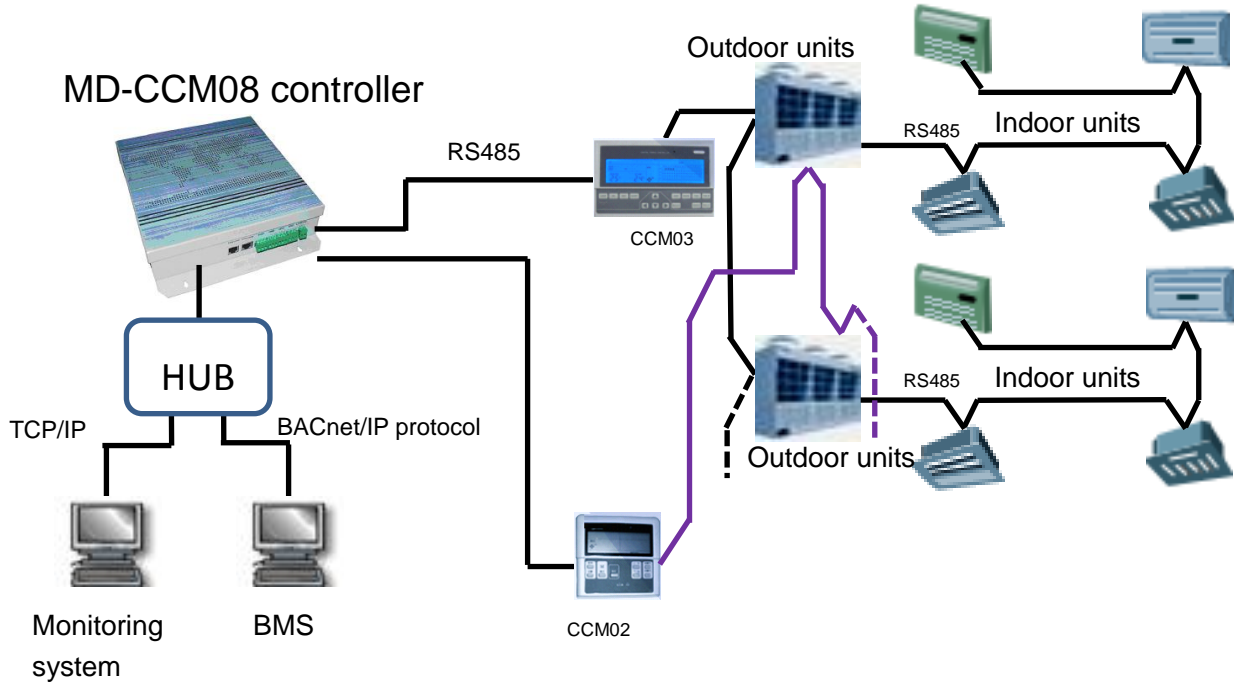

If there are a few MD-CCM08 applied in the system, the MD-CCM08 can be connected to the HUB and then connected to the monitoring system and BMS.

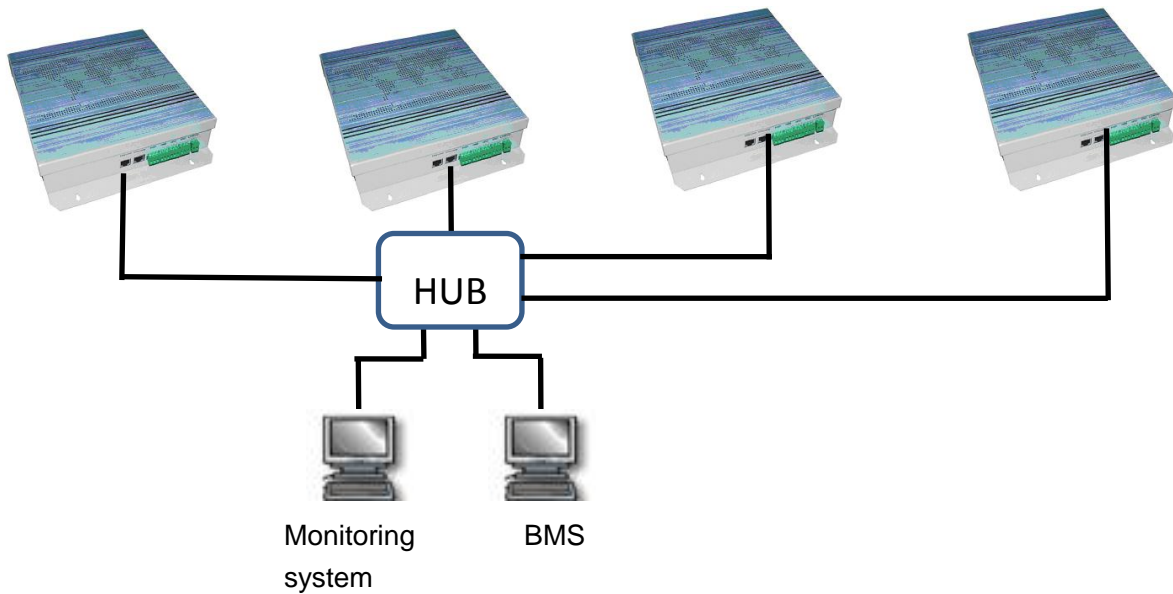

Note: MD-CCM08 and the BMS computer must be at the same subnet address field. Or else, the device cannot work normally. The default address of CCM08 is set to be under the segment “192.168.*.*”.

2.5.1.2 Connecting ports and functions

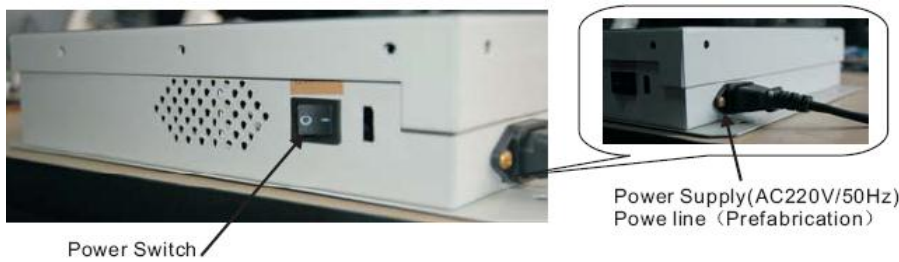
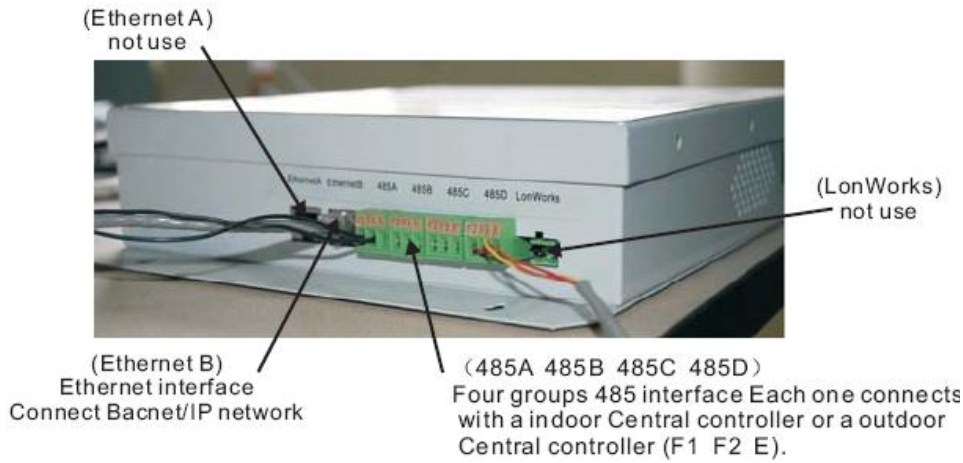

MD-CCM08 has some kinds of connecting ports. EthernetA and LonWorks ports are used for further function designed and do not function by now.

Ethernet B port is an Ethernet interface base on the BACnet network protocol. Connect this port with the BACnet HUB, then the device connect to the HUB can communicate with the MD-CCM08.

485A-485D: 4 groups of RS-485 communicative port. Each port can be connected to a MD-CCM02 or MD-CCM08 via the “F1, F2, E” terminals.

2.5.1.3 WEB access

MD-CCM08 can offer web service, which allows users access the gateway from the local computer network. Type the address of MD-CCM08 in the explorer’s address field and users can view then MD-CCM08’s connecting status or change the working status of the indoor units. The interfaces are as follows:

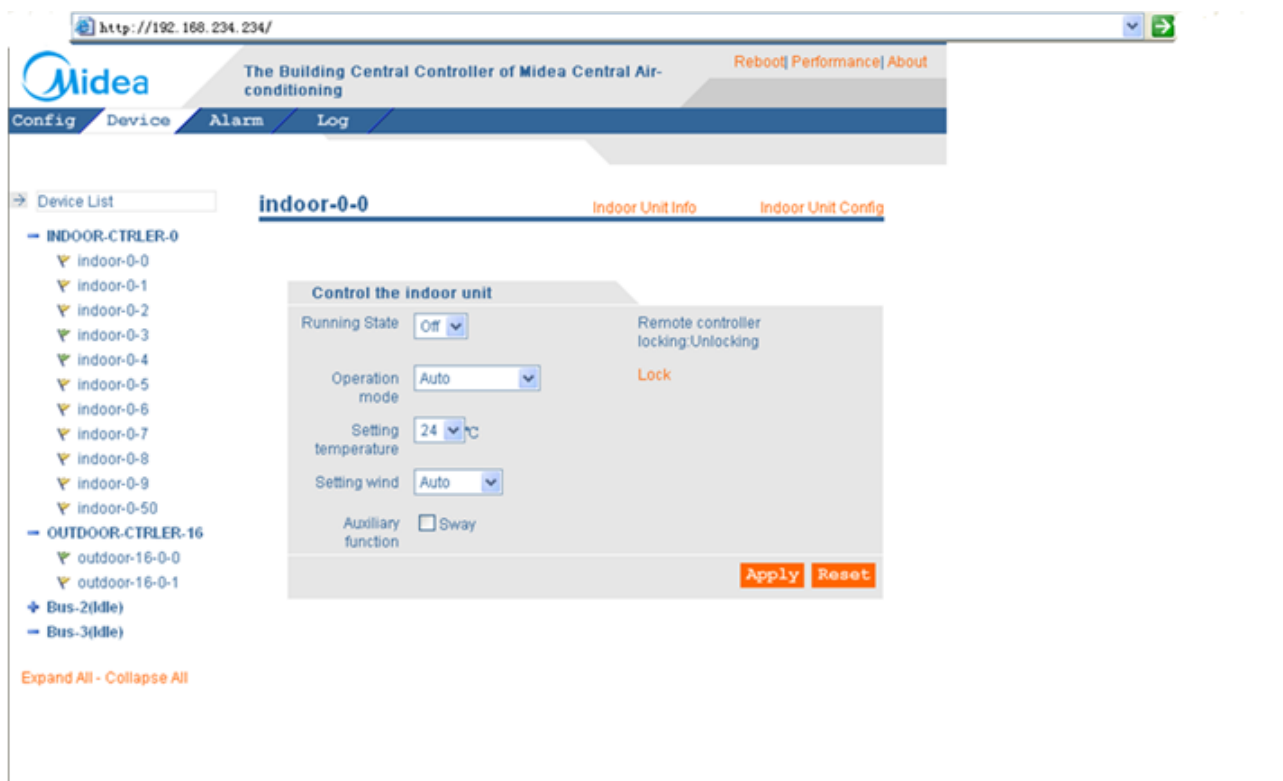
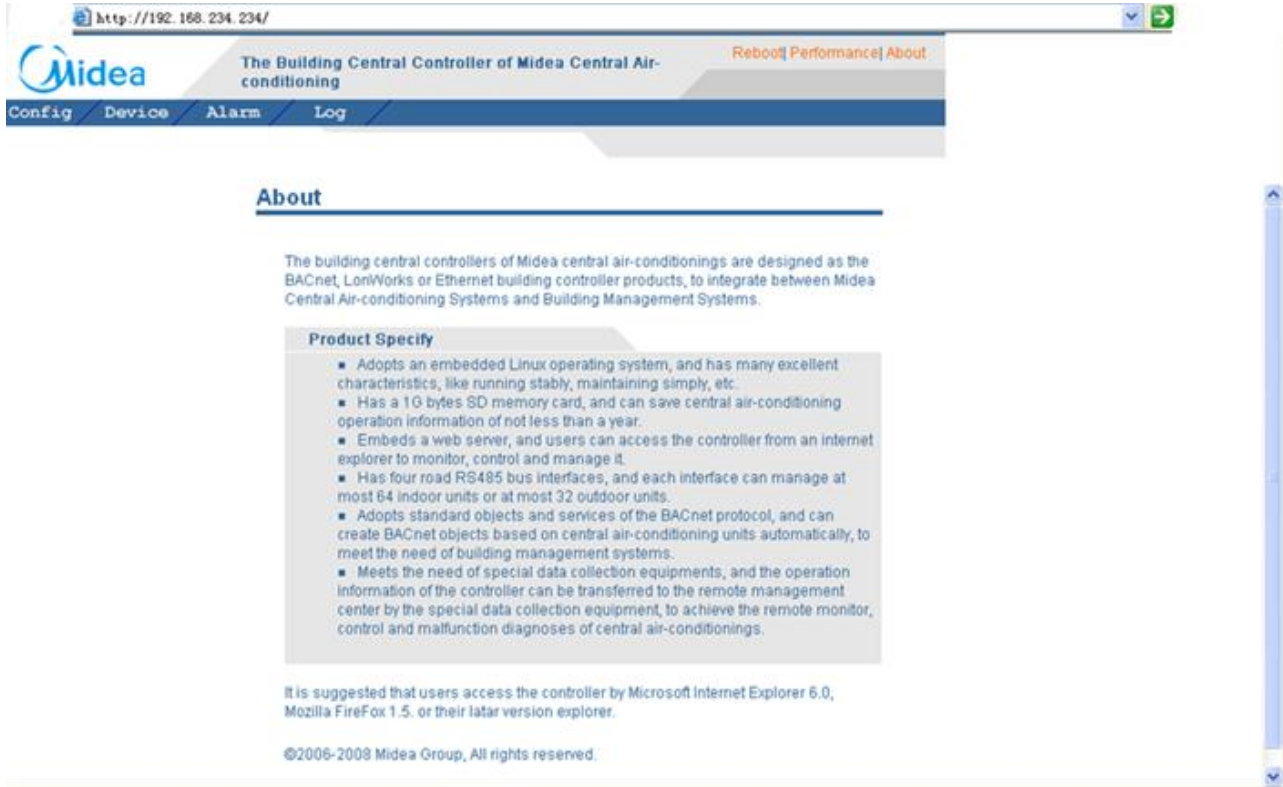





Note: The address “192.168.234.234” is not constant in every CCM08. Users can find the default address in the package. Please modify the address of MD-CCM08 and make sure that the address is in the same subnet with the BMS computer before used.

Moreover, the default administrator account to login the MD-CCM08 is “Admin”, default password “123456”. To save the air conditioner’s running data, an SD card is needed but not included in this product. Users can purchase one from the market. SD cards of different volume can save different periods of running data. Normally an SD card of 1 GB is able to save the data of more than 1 year.

2.5.1.4 Available BMS

MD-CCM08 has a wonderful adaptability to the BMS. It can be connected to many company’s building management system software. We can get the mainly supporting BMS information from the table bellow:

	Company	BMS software	Brand
1	SIMENS	APOGEE	
2	TRANE	Tracer Summit	
3	Honeywell	Alerton	
4	Schneider	Andover	
5	Johnson	METASYS	

2.5.2 Building gateway MD-CCM07/E

MD-CCM07/E is a gateway to connect the indoor units and outdoor units to the LonWorks network. MD-CCM07/E helps other LonWorks devices gathering the information from the Midea central A/C, and help setting the indoor units’ working mode. Compared with the MD-CCM07/E, MD-CCM08 needs a computer and the 3rd generation monitoring software.



**Connect Central A/C system to LonWorks network.
The core control module applies flash memory.
Easily download the program on line.
CCM07 applies nonpolar twisted pair lines, which makes connecting to LonWorks network easily.**

2.5.2.1 System configure

MD-CCM07 is a gateway from the 3rd network control software to the LonWorks, which can gather all the

units' information and control the indoor units. As a result, the indoor and outdoor units need firstly connecting to the computer to make a central monitoring system. The composition of the whole network is as follows:

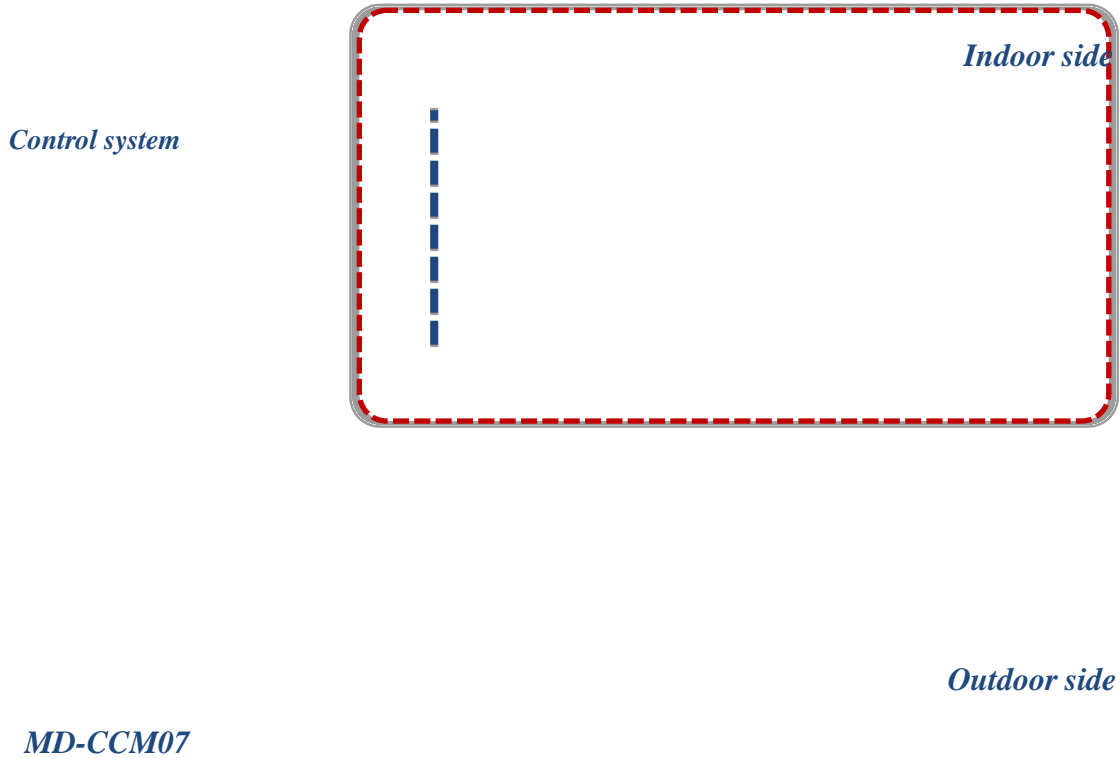

If there are a few MD-CCM07 devices to compose a LonWorks network, the LonWorks terminals of the MD-CCM07 are able to be connected in the hand-in-hand way.

2.5.2.2 Connecting ports and functions

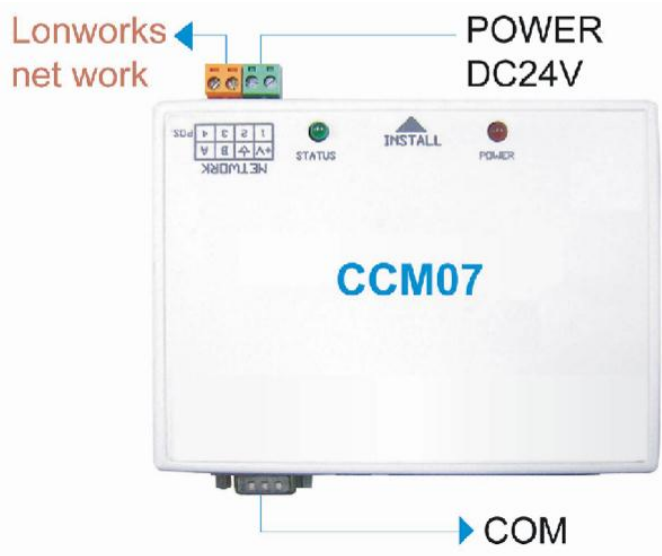

COM port: This port should be connected to the computer's COM port, using the RS-232 communicative standard.

LonWorks: This port uses a removable connecting way to help user connect the LonWorks network conveniently.

DC POWER: MD-CCM07 is an active gateway, so MD-CCM07 inquires a power supply of DC 24V. This port should be connected to the DC power adaptor.

2.5.2 Network control software MDV-WLJKXT/E(V3.1)(Firebird)

Please refer to “installation and operation manual” of “3rd generation network control software”.

2.6 Other Accessory

Assy.	Model	Description
Digital ammeter	DTS634/DT636	Send the electric energy data to outdoor unit for realizing network fee charge function.
Hotel card-inserter assy.	MD-NIM05/E	Match hotel card system to control the air conditioning.
Infrared sensor	MD-NIM09/E	Detects changes in infrared radiation which occur when there is movement by a person(or object).
Mode lock controller		

2.6.2 Hotel card-insert accessories MD-NIM05/E and MD-NIM05/E-1

MD-NIM05/E and MD-NIM05/E-1 are mainly designed for the hotel card-insert system. It offers a smart way to save energy and manage the air conditioners.

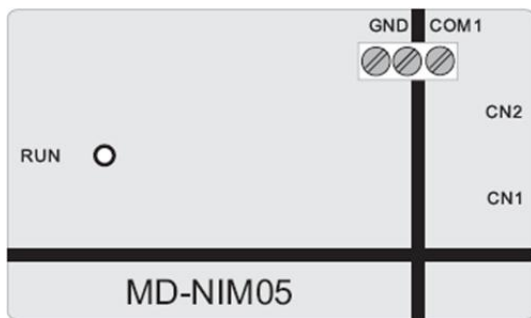

- **A smart way to save energy and money.**
- **Cooperates with the hotel card-insert system.**
- **Extra power supply is unnecessary.**
- **Connected but insulate to the card-insert system**
- **Easy to install.**

The main difference between MD-NIM05/E and MD-NIM05/E-1 is that MD-NIM05/E-1 is able to record the running status after power off and recover the unit to the previous running status. While MD-NIM05/E runs the unit to the default starting status after power off.

2.6.2.1 Wiring

When the card is inserted, to turn on the air conditioner, the terminal COM1 and GND should be connected or short. So the card-insert system should send the signal to the terminal COM1 and GND. The wiring diagram should be as follows.

Wiring diagram:

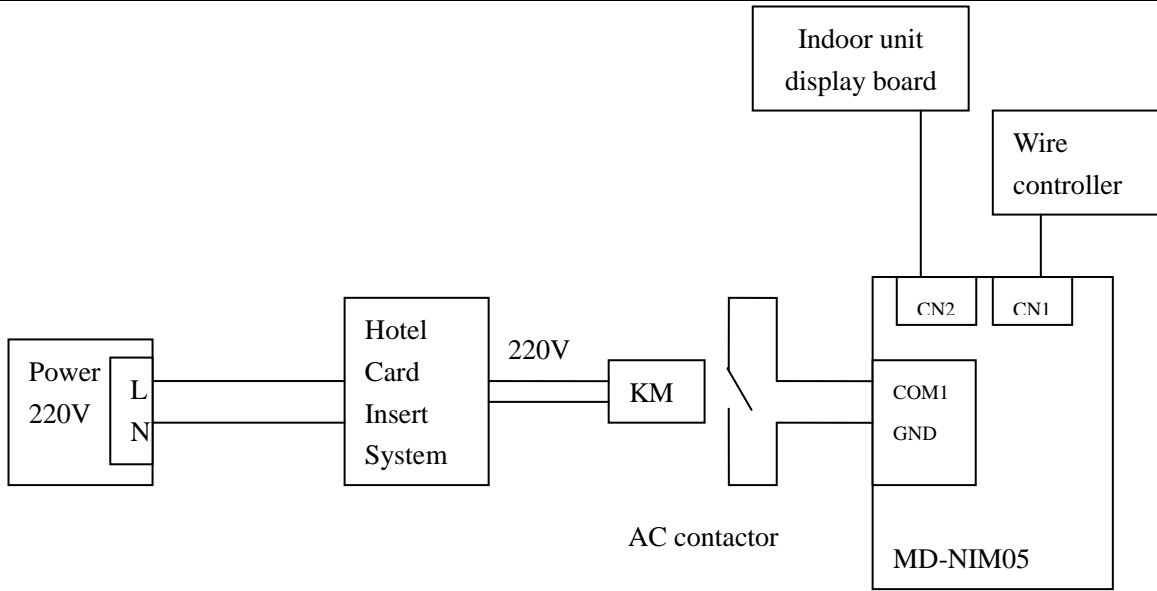

Note:

- 1) An AC contactor or a delay is necessary to transform the signal.
- 2) Wiring assy. 1 connects the CN1 of hotel card-insert assy. to wire controller of air conditioner.
- 3) Wiring assy. 2 connects the CN2 of hotel card-insert assy. to display board and main control board of air conditioner indoor unit.

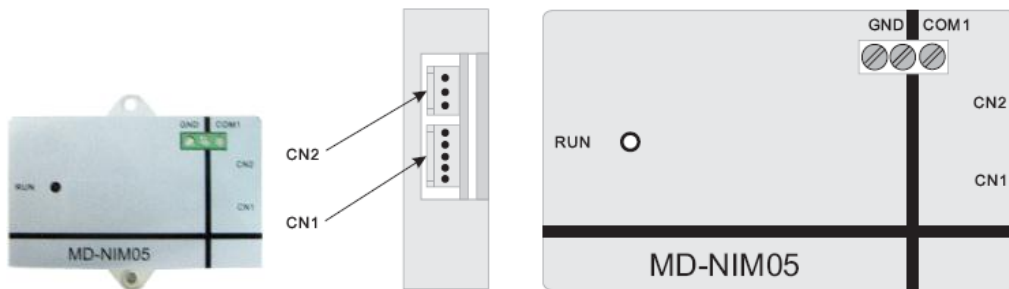

Note: COM1 and GND terminals should be short to work and not be connected to the power. The electricity voltage over 5V will probably damage the device or get the device burnt and cause fire.

2.6.2.2 Installation

Dimensions

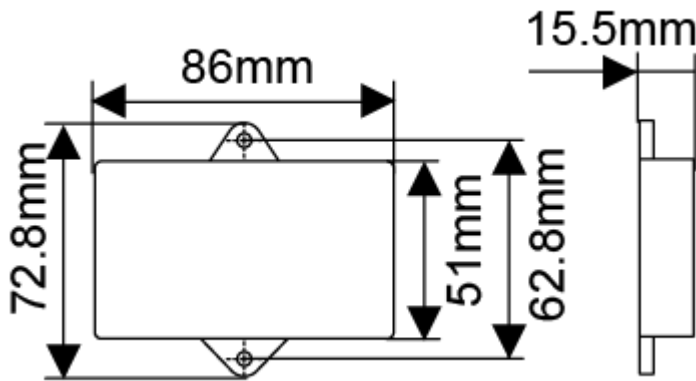

Wires

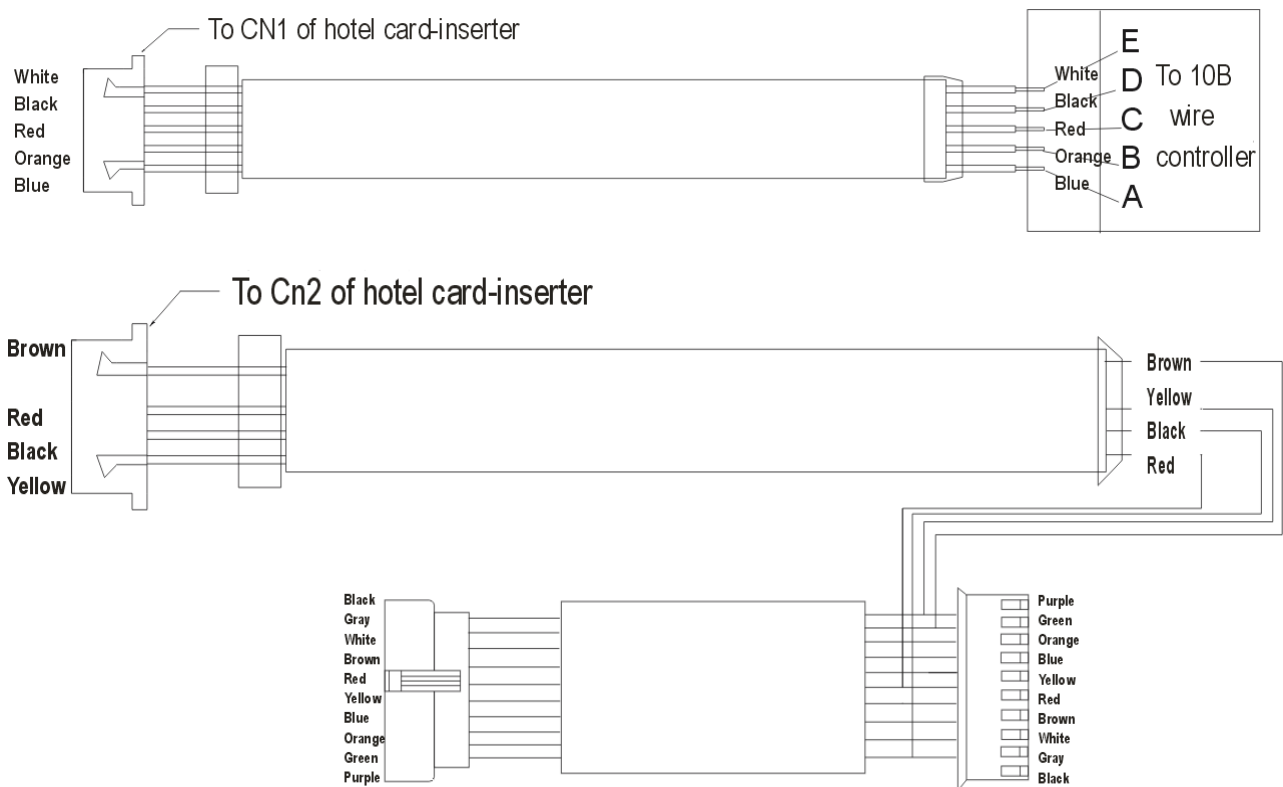

2.6.2.3 Operation description

- 1) Connect 5-place terminal at fixed rated wire controller via 5 terminals: A, B, C, D, E.
- 2) Connect LCD at main control panel of indoor unit via terminals REV, C, D, E.
- 3) Upon wiring according to the wiring diagram in, Please power to the wire controller and switch on it. When card has been inserted between in COM1 and GND, air conditioner is turn on and its operation mode could be set, the director lamp at wire controller is light-up.
- 4) When no card has been inserted between in COM1 and GND (i.e. It not be short connected), the ON/OFF button of wire controller cannot start air conditioner, but two beeps of air conditioner closed down signals be giving out and no lamp is light-up at wire controller.
- 5) User must apply wire controller to turn on air conditioner and set operation modes every time power is input. After then, operation modes of this performance would be memorized, although took off card and than insert it on again, as long as power does not be cut off from main unit. i.e. air conditioner will turn off when card is took off, while insert it on again unit will perform as per the last setting.

Notice: the first start-up of main unit and mode setting must apply wire controller.

- 6) System can receives signal delivering from fixed rated wire controller (KJR-10B), and transmits the signal

to indoor unit; it can also memorizes the latest ON/OFF information sending by wire controller (Timing information be transited but memorized.)

7) Upon powered to card-inserter, transited signal defaults as unit shutdown. Once take off the card, system will send signal of unit shutdown twice; till to the next time card is inserted, system will not start unit until 3 seconds later, because of memory information delivery.

2.6.3 Infrared Sensor MD-NIM09/E

CE-MD-NIM09/E is an infrared sensor, which is able to detect whether there is people nearby and auto change the air conditioner back to running mode. This humanistic device helps making a comfortable environment for the users and the turning down the conditioner automatically.



- **Be easy to install on the wall or ceiling.**
- **Be with a wide detective angle up to 100° .**
- **Detective distance is at least 4M, great sensibility.**
- **Be powered from the indoor unit display panel. Safe and extra power supply is unnecessary.**

2.6.3.1 Wiring of MD-NIM09/E

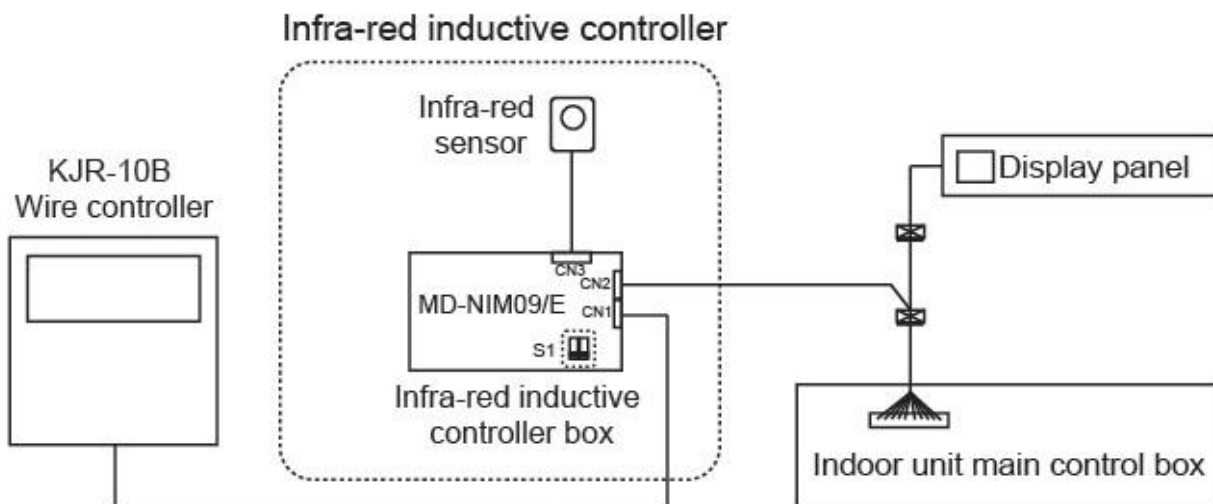

The infrared sensor MD-NIM09/E contains a sensor and a control box. The control box helps connecting the device to the wire controller and the indoor unit.



As show above, the MD-NIM09/E has 3 connecting port.

CN1 is used for connecting the wire controller.
 CN2 is used for connecting the indoor unit's display panel.
 CN3 is used for connecting the infrared sensor.

The switch S1 stands for:

ON  1 2	Turn off the indoor units in 1 hour after users leave.
ON  1 2	Turn off the indoor units in 0.5 hour after users leave.
ON  1 2	Reserved.

2.6.3.2 How to use?

The general function of MD-NIM09/E is turning down the indoor unit automatically. So users should run the indoor unit firstly and adjust the temperature, fan speed, etc, via the wire controller. Once set, users do not need to turn down the indoor unit. The MD-NIM09 will turn it down automatically after the users leave. Once the users come to the infrared sensor's detective area, the MD-NIM09 turn the indoor unit on and runs it at the status which is set previously..

2.6.3.3 Installation

Dimensions

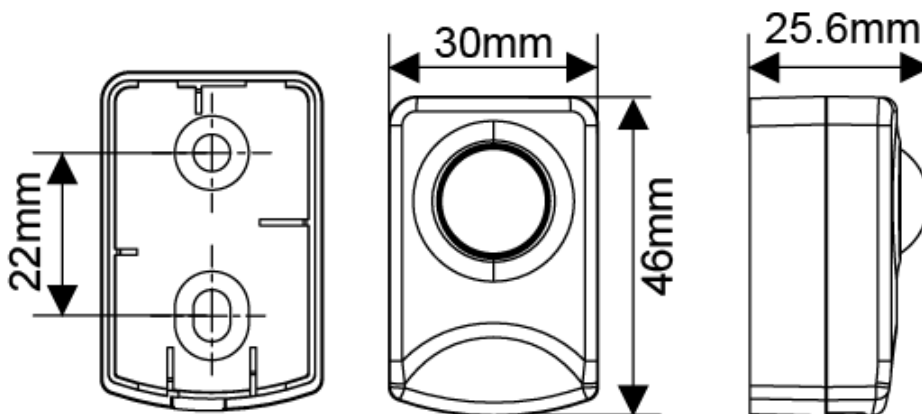

Infrared sensor

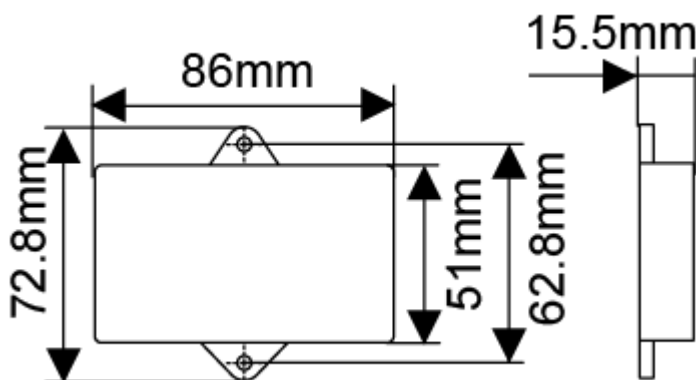

Control box

Connecting and Assembly

General Information

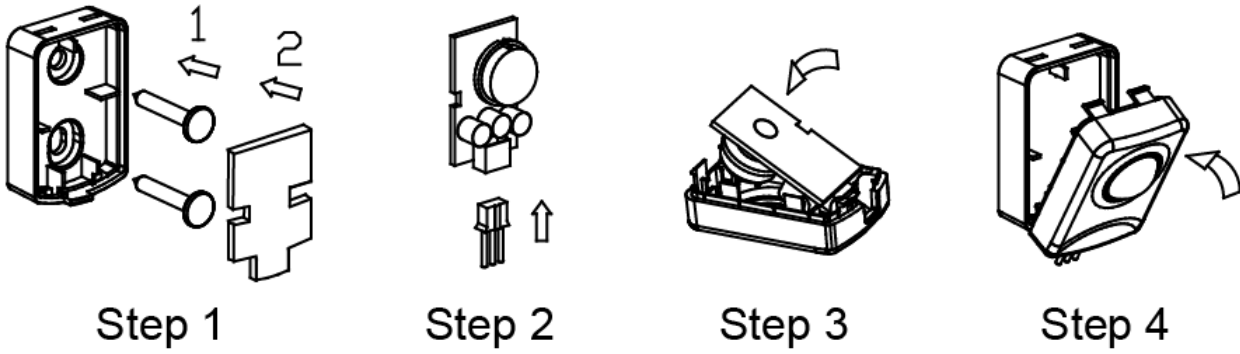

Wires

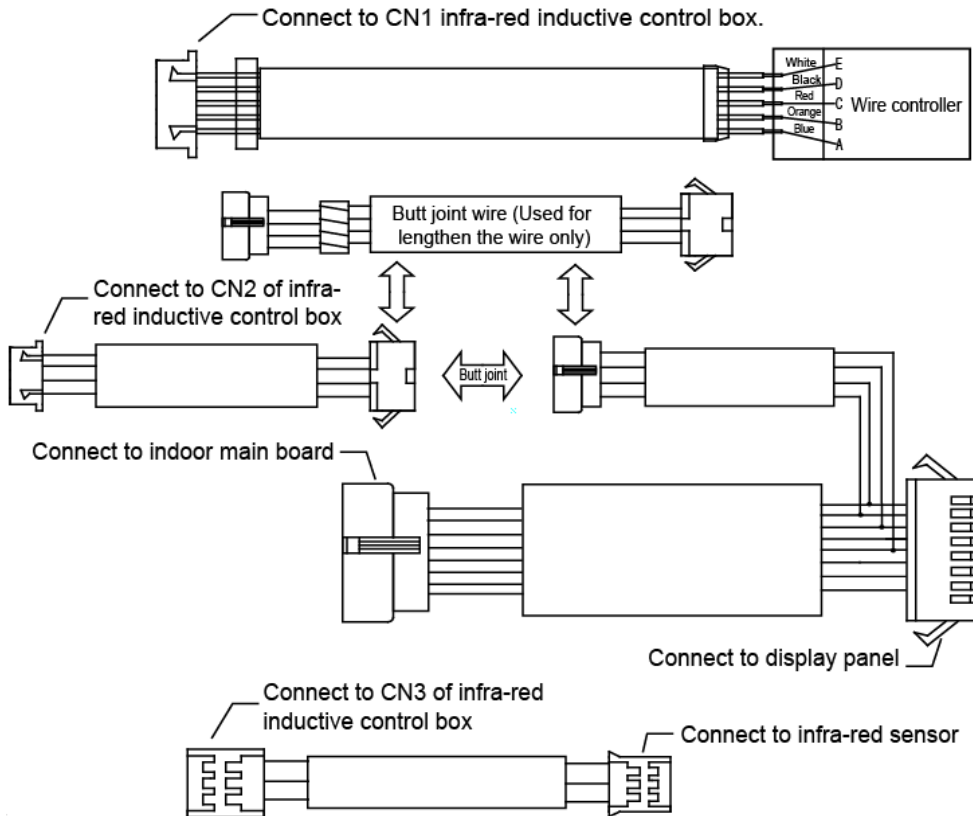

2.6.4 Computer diagnostic modules and software MCAC-DIAG/E

MCAC-DIAG/E is remote diagnostic software, which is able to inquire the outdoor unit's running status and make the running charts. This software takes advantage of the outdoor unit's K1, K2, E terminals. As a result, the centralized controller CCM02 is unable to connect to the outdoor units and unable to work with the network monitoring software.

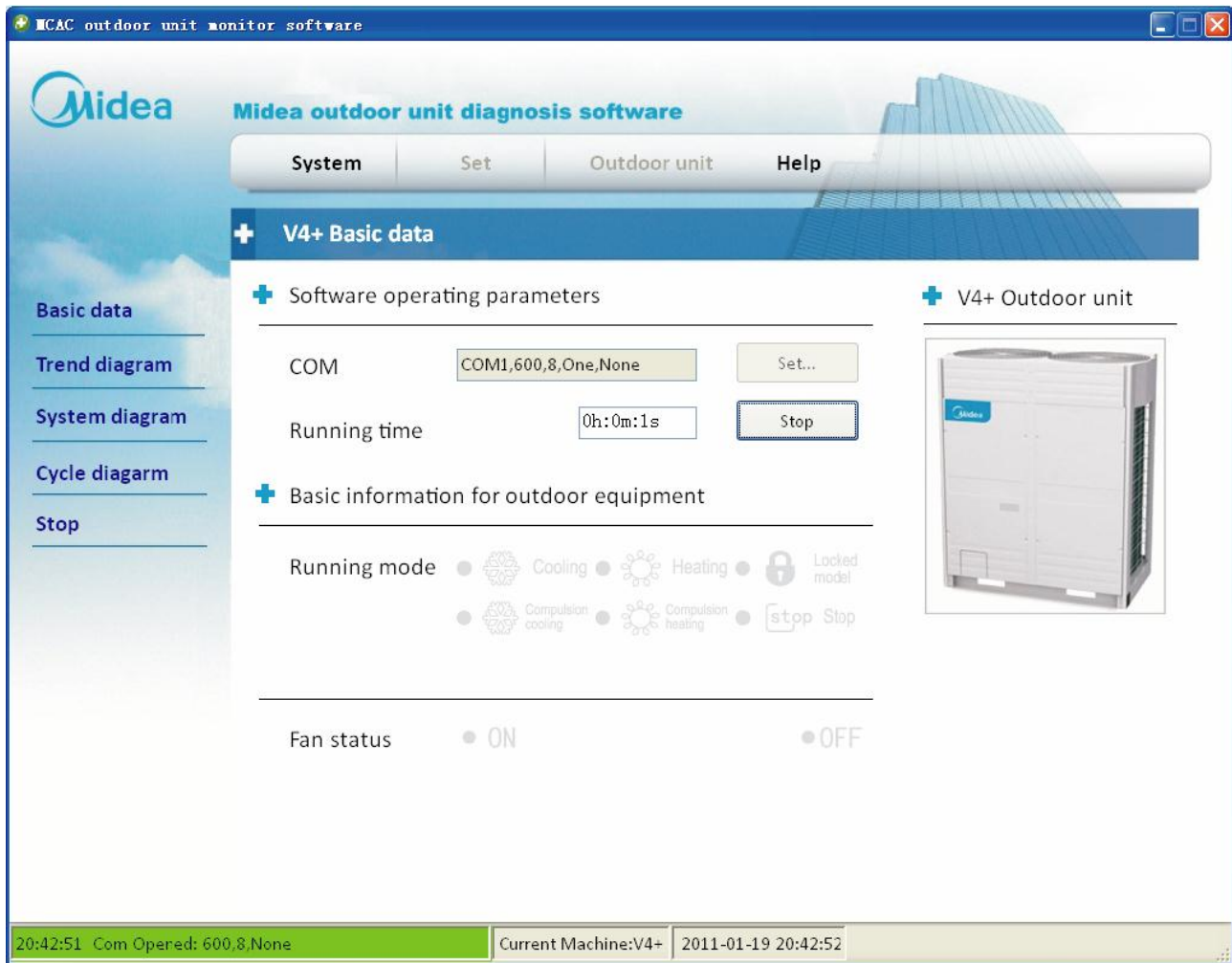

Please refer to “installation and operation manual” of the “Midea Outdoor Unit Diagnosis Software manual”.