

## Part 4 Installation

1. Precautions .....	44
2. Main units installation .....	45
3. Water system installation.....	50
3.1 Basic requirements of connection of chilled water pipes .....	50
3.2 Positions of water inlet, outlet and drainage port .....	51
3.3 Installation of drainage port connecting pipes.....	51
3.4 Installation of the main unit water pipelines .....	52
3.5 Installation & regulation guide for water flow switch.....	54
3.6 Operations and maintenance of double-pipe heat exchanger .....	55
3.7 System water quality requirements and management.....	56
4. Refrigerant Pipe Engineering.....	58
4.1 Length and drop height permitted of the refrigerant piping.....	58
4.2 Select the Refrigerant Piping Type .....	60
4.3 Size of joint pipes for indoor unit .....	60
4.4 Size of joint pipes for main unit .....	60
4.5 Branch pipes for main unit.....	61
4.6 Branch pipes for indoor unit .....	61
4.7 Example .....	62
4.8 Remove dirt or water in the piping .....	63
4.9 Gas tight test .....	63
4.10 Vacuum with vacuum pump.....	64
4.11 The installation key points of connective pipes between main units..	65
5. TRIAL RUN .....	67

# 1. Precautions

■ Be sure only trained and qualified service personnel to install, repair or service the equipment. Improper installation, repair, and maintenance may result in electric shocks, short-circuit, leaks, fire or other damage to the equipment.

If installation is defective, it will cause water leakage, electrical shock fire.

■ When installing the unit in a small room, take measures against to keep refrigerant concentration from exceeding allowable safety limits in the event of refrigerant leakage. Contact the place of purchase for more information. Excessive refrigerant in a closed ambient can lead to oxygen deficiency.

■ Use the attached accessories parts and specified parts for installation.

Otherwise, it will cause the set to fall, water leakage, electrical shock fire.

■ Install at a strong and firm location which is able to withstand the set's weight.

If the strength is not enough or installation is not properly done, the set will drop to cause injury.

■ The appliance shall be installed in accordance with national wiring regulations

■ The appliance shall not be installed in the laundry.

■ Before obtaining access to terminals, all supply circuits must be disconnected.

■ The appliance must be positioned so that the plug is accessible.

■ The enclosure of the appliance shall be marked by word, or by symbols, with the direction of the fluid flow.

■ For electrical work, follow the local national wiring standard, regulation and this installation instructions. An independent circuit and single outlet must be used.

If electrical circuit capacity is not enough or defect in electrical work, it will cause electrical shock fire.

■ Use the specified cable and connect tightly and clamp the cable so that no external force will be acted on the terminal.

If connection or fixing is not perfect, it will cause heat-up or fire at the connection.

■ Wiring routing must be properly arranged so that control board cover is fixed properly.

If control board cover is not fixed perfectly, it will cause heat-up at connection point of terminal, fire or electrical shock.

■ If the supply cord is damaged, it must be replaced by the manufacture or its service agent or similarly qualified person in order to avoid a hazard.

■ An all-pole disconnection device which has at least 3mm separation distance in all pole and a residual current device(RCD)with the rating of above 10mA shall be incorporated in the fixed wiring according to the national rule.

■ When carrying out piping connection, take care not let air substances go into refrigeration cycle. Otherwise, it will cause lower capacity, abnormal high pressure in the refrigeration cycle, explosion and injury.

■ Do not modify the length of the power supply cord or use of extension cord, and do not share the single outlet with other electrical appliances. Otherwise, it will cause fire or electrical shock.

■ Carry out the specified installation work after taking into account strong winds, typhoons or earthquakes.

Improper installation work may result in the equipment falling and causing accidents.

■ The temperature of refrigerant circuit will be high, please keep the interconnection cable away from the copper tube.

■ The power cord type designation is H07RN-F. Equipment complying with IEC 61000-3-12.

■ If the refrigerant leaks during installation, ventilate the area immediately.

Toxic gas may be produced if the refrigerant comes into the place contacting with fire.

■ After completing the installation work, check that the refrigerant does not leak.

Toxic gas may be produced if the refrigerant leaks into the room and comes into contact with a source of fire, such as a fan heater, stove or cooker.

## 2. Main units installation

### 2.1 Main unit combination

HP	Mode	Qty. of indoor unit	HP	Mode	Qty. of indoor unit
8	8HP×1	13	24	12HP×2	39
10	10HP×1	16	26	8HP×2+10HP	43
12	12HP×1	19	28	10HP×2+8HP	46
16	8HP×2	23	30	10HP×3	50
18	10HP+8HP	29	32	10HP×2+12HP	53
20	10HP+10HP	33	34	12HP×2+10HP	56
22	10HP+12HP	36	36	12HP×3	59

### 2.2 Dimension of main unit

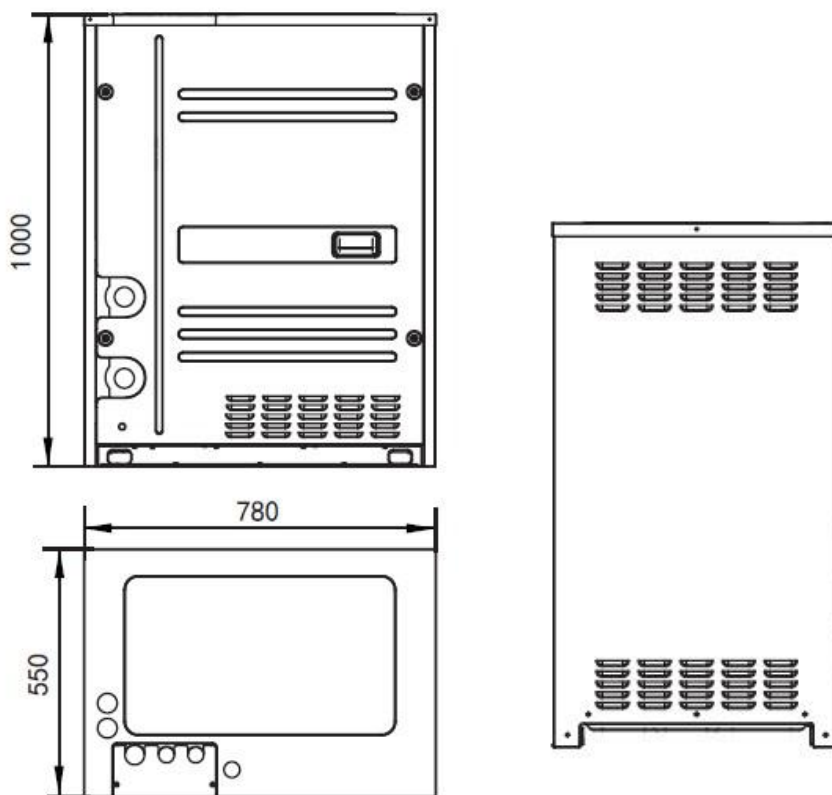

### 2.3 Selecting installation position

- Ensure that the main unit is installed in a place convenient to connect water, refrigerant and electricity.
- Ensure that the noise and exhaust ventilation of the main unit do not affect the neighbors of the property owner or the surrounding ventilation.
- Ensure that the main unit is installed in a well-ventilated place that is possibly closest to the indoor unit.
- Ensure that the main unit is installed in a cool place without direct sunshine exposure or direct radiation of high-temp heat source.
- Do not install the main unit in a dirty or severely polluted place, so as to avoid blockage of the heat exchanger in the main unit.
- Do not install the main unit in a place with oil pollution, salt or high content of harmful gases such as sulfurous gas.

## 2.4 Hoisting main unit

■ It is banned to take wooden cork base as the force bearing point of lifting up the unit during hoisting, the correct method is use the braces or lifting ropes which can bear the unit's weight and go through the lifting holes of the front and back bottom plates in the unit for hoisting.

■ It is banned to tear down any packages during hoisting installation; it should use two longer than 4m ropes to lift up the unit with the packages, and keep the unit in balance, lift it up stably. Under transporting the unit with no packages or the package has been damaged, it should use base plate or packaging materials for protection.

■ Pay attention to keep the main unit vertical during transportation, hoisting, and make sure the safety during transportation and hoisting.

## 2.5 Base for main unit

■ A solid, correct base can:

- Avoid the main unit from sinking.
- Avoid the abnormal noise generated due to base.

■ Base types

- Steel structure base
- Concrete base (see the figure below for the general making method)

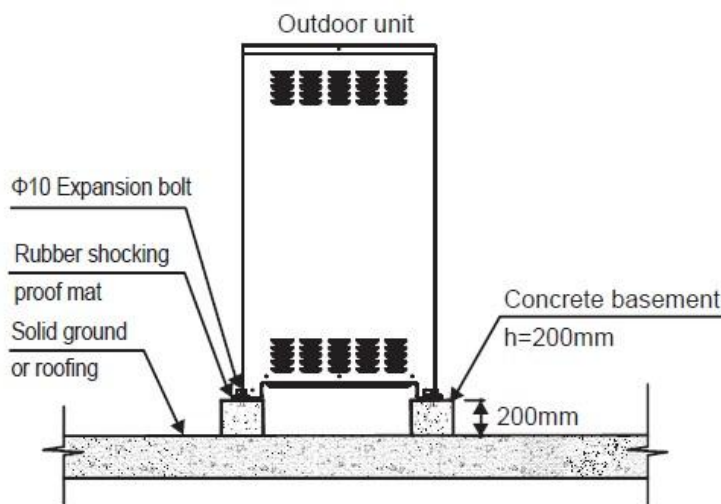

### CAUTION:

■ The key points to make basement:

- The master unit's basement must be made on the solid concrete ground . Refer to the structure diagram to make concrete basement in detail, or make after field measurements.
- In order to ensure every point can contact equality, the basement should be on completely level.
- If the basement is placed on the roofing, the detritus layer isn't needed, but the concrete surface must be flat. The standard concrete mixture ratio is cement 1/ sand 2/ carpolite 4, and add Φ10 strengthen reinforcing steel bar, the surface of the cement and sand plasm must be flat, border of the basement must be chamfer angle.
- Before construct the unit base, please ensure the base is directly supporting the rear and front folding edges of the bottom panel vertically, for the reason of these edges are the actual supported sites to the unit.
- In order to drain off the sweeper around the equipment, a discharge ditch must be setup around the basement.
- Please check the afford ability of the roofing to ensure the load capacity.

■ Position illustration of screw bolt (Unit: mm)

(Unit: mm)

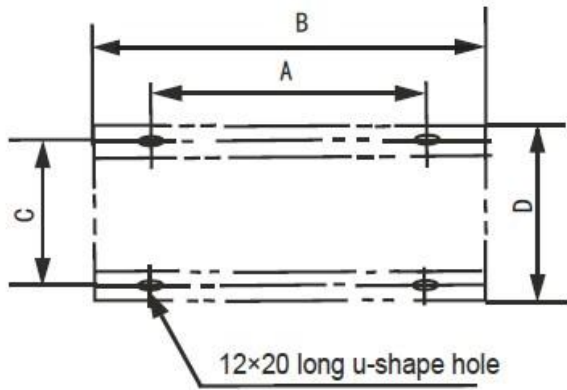

SIZE	HP	8,10,12
A		650
B		780
C		518
D		550

Centering position illustration of each connective pipe (Unit: mm)

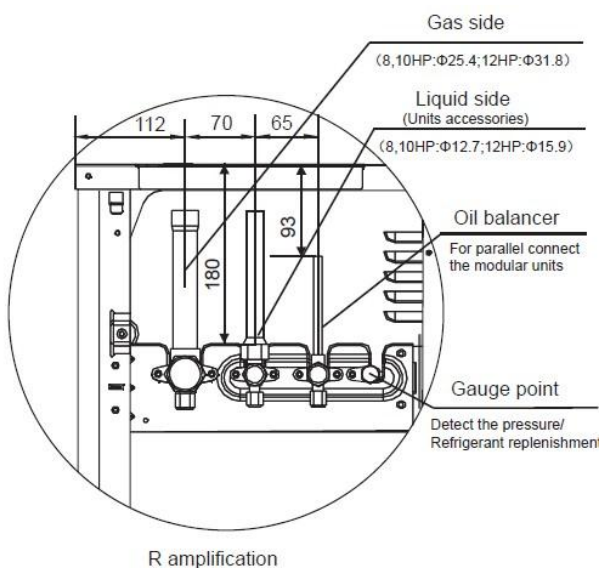
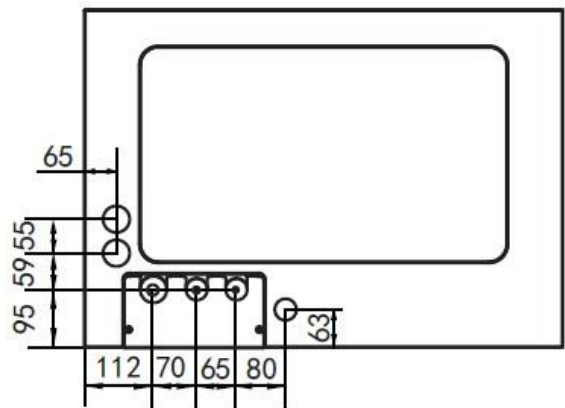
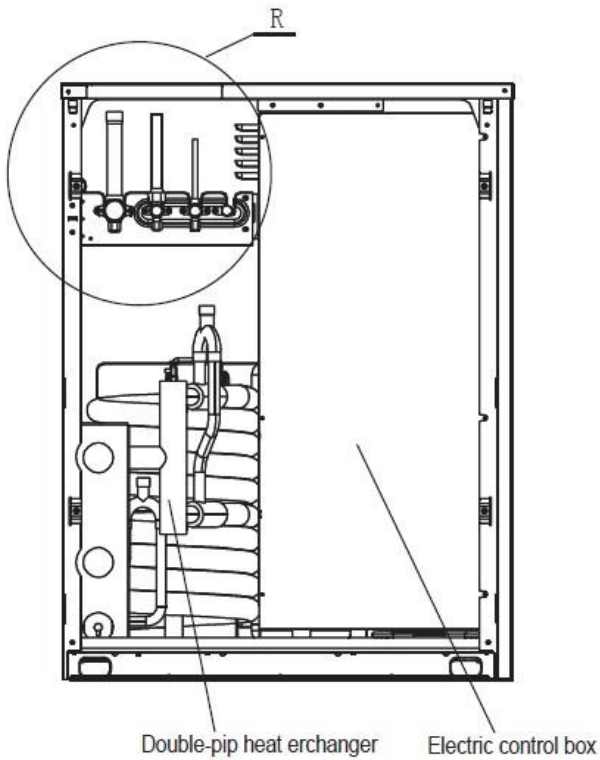

## 2.6 Main units' placement sequence & master and slave units' settings

A system, which provide with more than two main units, will be set as the followings method: The main units in this

system should place sequentially from the large to the small capacity; the largest capacity main unit must be mounted at the first branching site; and set the largest capacity main unit address as the master unit, while the other setting as the slave unit. Take 18HP (composed by 10HP, 8HP ) as an example:

- 1) Place the 10HP at a side of the first branching site.
- 2) Place the unit from the large capacity to the small (See the detail placement illustration).
- 3) Set 10HP as the master unit, while the 8HP as the aux. unit.

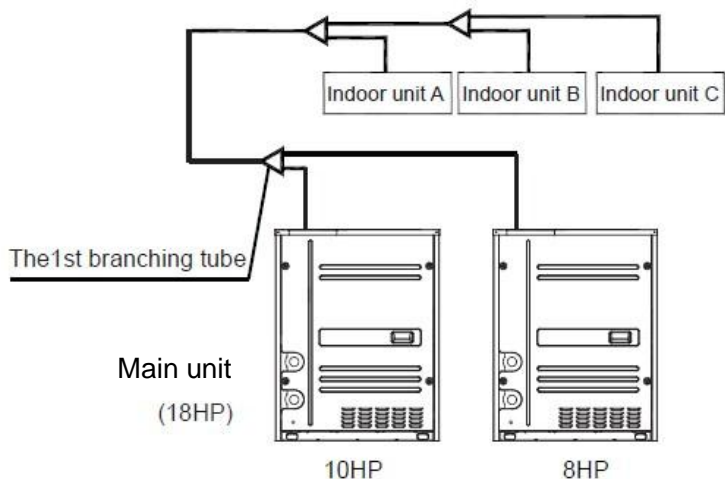

## 2.7 Installation space for main unit

- Ensure enough space for maintenance. The modules in the same system must be on the same height.
- When installing the unit, leave a space for maintenance. Install the power supply at the side of the main unit. For installation procedure, see the power supply device installation manual.

### ■ Installation space of single main unit

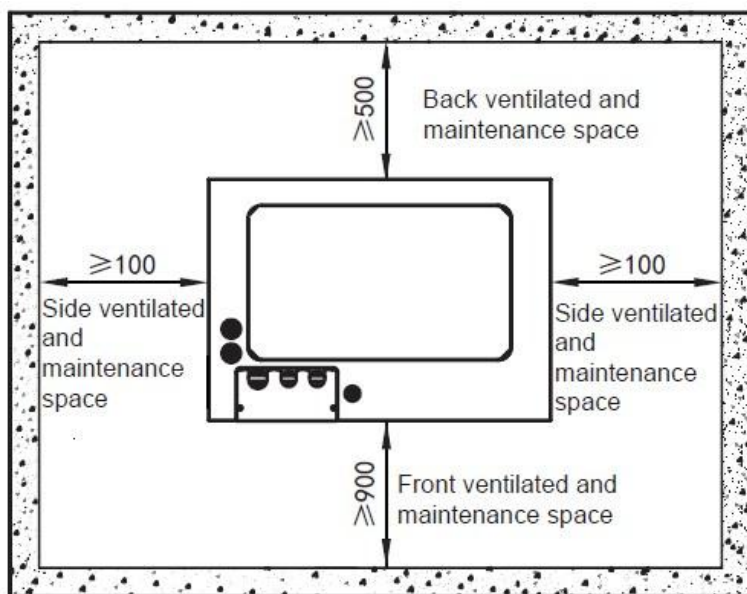

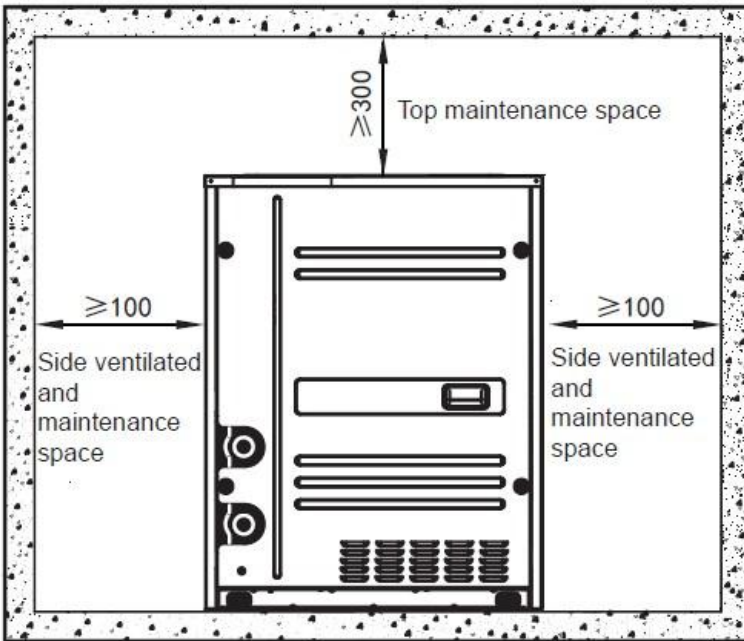

■ Installation space of several main units

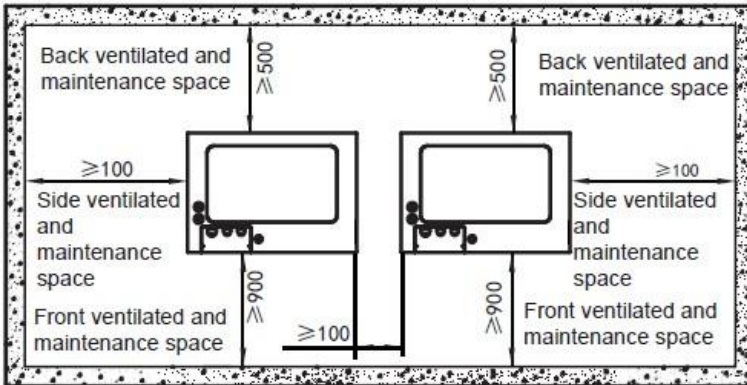

**CAUTION:**

When install several main units, please reserve the top maintenance space as the single main unit installation.



### 3. Water system installation

#### 3.1 Basic requirements of connection of chilled water pipes

**CAUTION:**

- After the unit is in place, chilled water pipes can be laid.
  - The relevant installation regulations should be abided with when conducting connection of water pipes.
  - All water pipes must conform to local rules and regulations of pipeline engineering.
  - The size of water pipe should be the same as or larger than the connector size of the unit (DN32).
  - The heat exchanger of the unit is double-pipe heat exchanger. There are different operation and maintenance methods between the double-pipe heat exchanger double-pipe heat exchanger and the other heat exchangers.
- 1) All connected water pipes should be thoroughly flushed, and cannot be cleaned after connected to the double-pipe heat exchanger of the unit, for in case any impurity been flushed into the heat exchanger. After connection, all the water pipes should be washed down, and no any impurity left.
  - 2) Water must enter the double-pipe heat exchanger through the inlet; otherwise the performance of the unit will decline.
  - 3) The inlet pipe of each double-pipe heat exchanger in the unit must be provided with a target flow switch, to realize flow-break protection for the unit. Both ends of the water flow switch must be supplied with horizontal straight pipe sections whose diameter is 5 times that of the inlet pipe. The water flow switch must be installed in strict accordance with “Installation & Regulation Guide for Water Flow Switch” (See Section 4-5).The wires of the water flow switch should be led to the electric cabinet through shielded cable (see Electric Wiring section for details). After the pipelines are installed, the water flow switch will be set properly according to the rated water flow of the unit.
  - 4) The pump installed in the water system should be equipped with starter and should be controlled by the unit. The unit only supplies the on, off controlling signal of water pump, and do not supply the power for the water pump.
  - 5) The pipes and their ports must be independently supported but should not be supported on the unit.
  - 6) The pipes and their ports of the double-pipe heat exchanger should be easy to disassemble for operation and cleaning, as well as inspection of port pipes of the evaporator.
  - 7) The inlet of the double-pipe heat exchanger should be provided with a water filter with more than 40 meshes per inch (in the accessories). The filter should be installed near to the inlet port as much as possible, and be under heat preservation. Periodically clean the water filter according to the blocking condition of the filter.
  - 8) The flexible connectors must be mounted between the double-pipe heat exchangers and the on-site pipes, to reduce transfer of vibration to the building.
  - 9) To facilitate maintenance, the inlet and outlet pipes should be provided with thermometer or manometer. The unit is not equipped with pressure and temperature instruments, so they need to be purchased by the user.
  - 10) All low positions of the water system should be provided with drainage valves, to drain water in the heat exchanger of water side and the system completely; and all high positions should be supplied with discharge valves, to facilitate expelling air from the pipeline. The discharge valves and drainage valves should not be under heat preservation, to facilitate maintenance.
  - 11) All possible water pipes in the system to be chilled should be under heat preservation.
  - 12) When the unit will not be used for a long time, water inside the unit should be drained and cut off the power. If the unit is not drained in winter, then the double-pipe heat exchanger and the water pipes system of the unit might be freezing and cracking under low temperature.



13) The rated water flow volume of different models are as follow:

Model	Rated water flow volume(m <sup>3</sup> /h)
8HP	5.4
10HP	6.0
12HP	7.2

**WARNING:**

- The water pipes network including water filters and heat exchangers should be periodically cleaned, otherwise, dreg or dirt may seriously damages the heat exchangers and water pipes.
- The installation persons or the users must ensure the quality of chilled water, and de-icing salt mixtures and air should be excluded from the water system, since they may oxidize and corrode steel parts inside the heat exchanger.

**3.2 Positions of water inlet, outlet and drainage port**

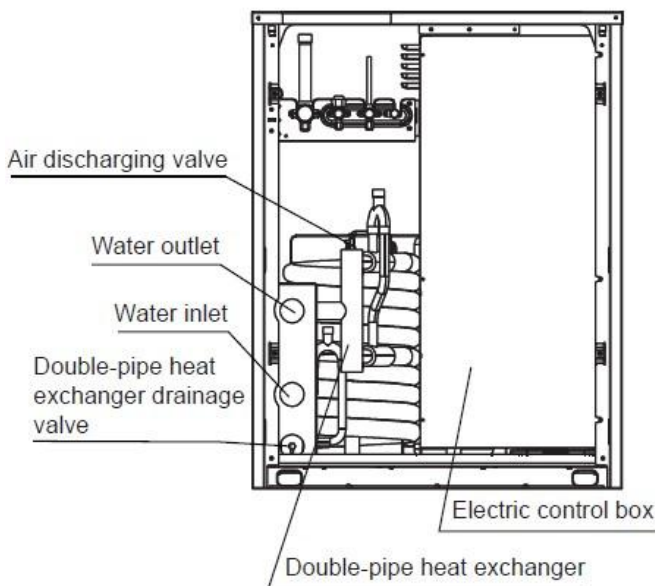

Fig.3-1

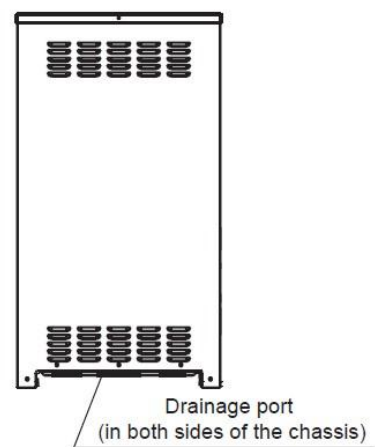
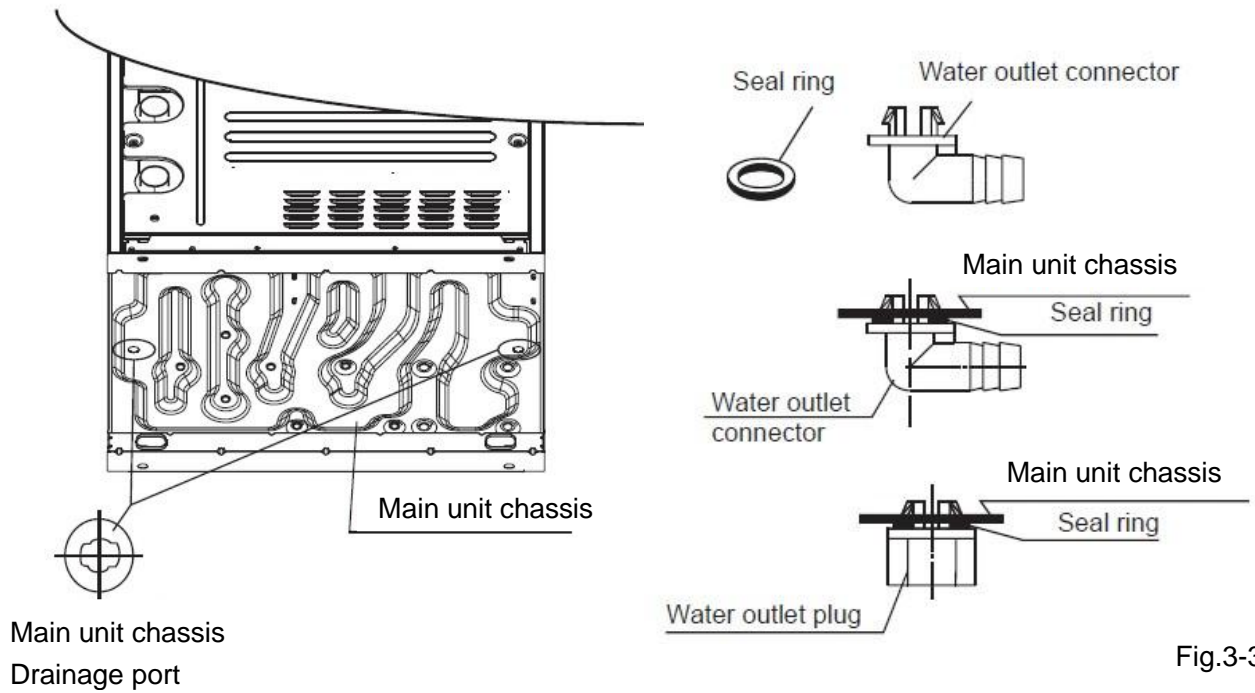

Fig.3-2

**3.3 Installation of drainage port connecting pipes**

According to the field installation condition, it is selected the side which is draining easily for installing the drainage port connecting pipes. During installation, the seal ring should be put on the water outlet connector, then install into the drainage hole in the chassis from the bottom of the unit, and then rotate 90° , to make it firmly assembled. And connect a drainage pipe (commercially available) with the water outlet connector, for draining the condensed water of the main unit out to the suitable place. Main unit chassis seal ring Water outlet connector main unit chassis drainage port water outlet connector main unit chassis seal ring water outlet plug main unit chassis seal.



**WARNING:**

It is needed to block the water outlet in the side which do not need to be connected with drainage pipes with water outlet plug and seal ring (see Fig.3-3), otherwise the condensed water produced during the system operation will drain near the installation place, to cause inconvenience.

**3.4 Installation of the main unit water pipelines**

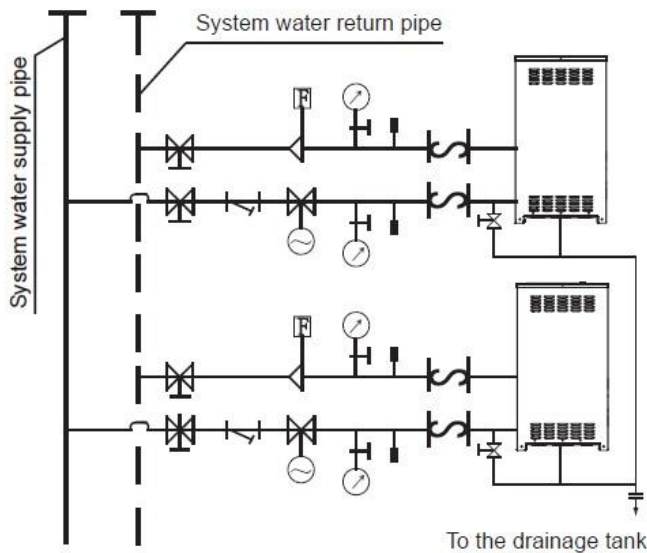

**Symbols description**

	Gate valve		Y-shape filter
	Pressure gage		Thermometer
	Water flow switch		Motorized valve
	Flexible connection		Drainage valve

Main unit side water pipelines connecting figure (Recommended)

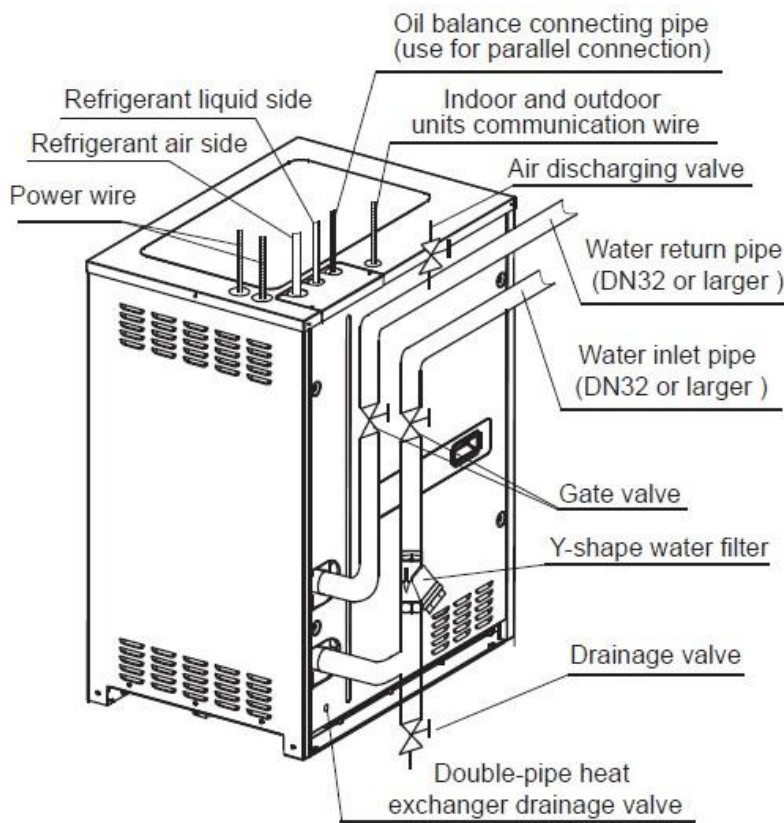

Fig.3-4 Direction schematic diagram of water system pipes

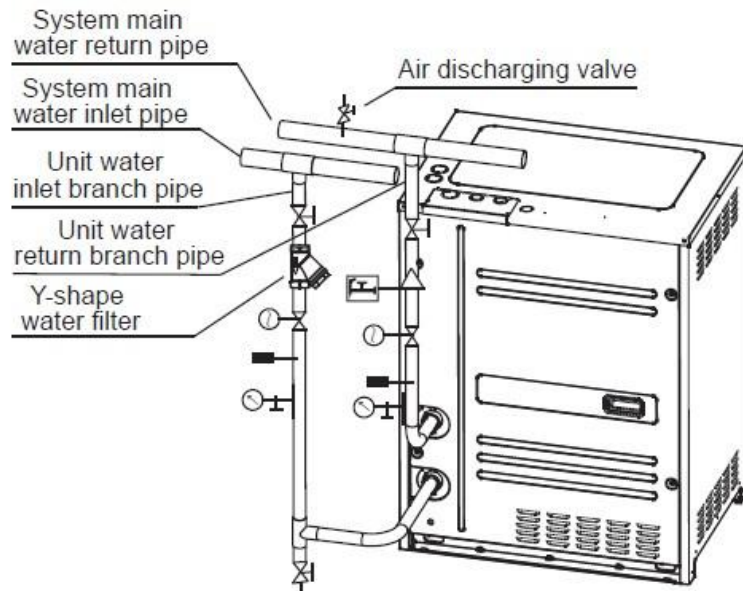







Fig.3-5

Symbols description

	Gate valve		Thermometer
	Pressure gage		Motorized valve
	Water flow switch		Drainage valve

As the above Fig.3-5, when horizontal installing the water system main water inlet pipe and main water return pipe, the water inlet branch pipe and water return branch pipe which connected with the unit must be separate connected from the vertically lower direction of main water inlet pipe and main water return pipe; if connected from the side direction and the top direction will affect the unit performance.

### **3.5 Installation & regulation guide for water flow switch**

3.5.1. Please carefully check flow switches before conducting installation of the water flow switch. Packing should be in good condition, and the appearance should be free of damage and deformation. If any problem, please contact the manufacturer.

3.5.2. Flow switches can be installed in the horizontal pipeline or the vertical pipeline with upward flowing direction but cannot be mounted in the pipeline with downward flowing direction. The inlet water of gravity should be taken into account when flow switches are installed in the pipeline with upward flowing direction.

3.5.3. Water flow switch must be installed on a section of straight-line pipeline, and its both ends must be supplied with straight-line pipes whose length is at least 5 times diameter of the pipe. In the meanwhile, the fluid flowing direction in the pipeline must be consistent with the direction of arrow on the switch. The connection terminal should be located where wiring connection can be easily done. (Fig.3-6).

3.5.4. Pay attention to the following items when conducting installation and wire connection:

- 1) Collision of the wrench with the soleplate of the flow switch is prohibited, since such collision may cause deformation and failure of the flow switch.
- 2) To avoid electric shock and damages to the devices, the power supply should be cut off, when wires are connected or adjustment is done.
- 3) When wiring connection is conducted, adjustment of other screws except connection terminals of micro switches and ground screws is prohibited. In the meanwhile, over great force should not applied when wires of micro switches are connected, otherwise micro switches may suffer displacement, thus leading to failure of flow switches.
- 4) Special grounding screws should be used for earth connection. Bolts should not be installed or removed at will; otherwise flow switches may suffer deformation and failure.
- 5) Flow switches have been set at minimal flow value prior to ex-factory. They should not be adjusted below the ex-factory setting value, or they may suffer failure. After installing flow switches, please press the flow switch lever several times to check them. When the lever is found not to respond with “clatter”, rotate the screw in a clockwise direction, until “clatter” occurs.
- 6) Be sure to determine the model of target slice according to the rated flow of the unit, the diameter of the outlet pipe and the adjustment range of the target slice of the flow switch. Besides, the target slice should not contact with other restrictors in the pipeline or on the inner wall of the pipeline, or the flow switch cannot be reset normally.

3.5.5. Determine whether the flow switch and the system connected with it are in good operation according to the measured value by flow meter, namely, when the measured value on flow meter is less than 50% of rated water flow of the unit, the water flow controller should be cut off and observed for 3 working periods, and it should be covered with flow switch shell timely.

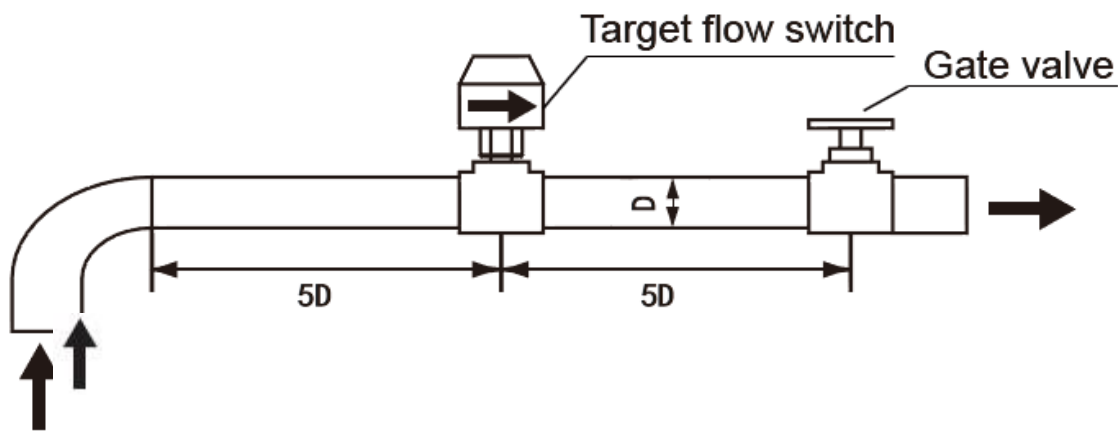

Fig.3-6

### 3.6 Operations and maintenance of double-pipe heat exchanger

#### 3.6.1 Operations of double-pipe heat exchanger

- 1) Please note that correctly install the water inlet and outlet pipes. The thread of water inlet and outlet are inner thread G1-1/4.
- 2) For the double-pipe heat exchanger is internal thread copper pipe, and for avoiding the impurities enter into and affect the performance then cause corrosion of the double-pipe heat exchanger, it must be installed the water filter (accessory) near the water inlet pipes of the unit.
- 3) Please use water pipes which conform to local rules and regulations of pipeline engineering. The size of water pipe should not smaller than the connector size of the unit (DN32).
- 4) Periodically clean the water filter according to the water quality situation and the blocking condition of the filter. Otherwise, it might damage the filter screen of the water filter because of the abnormal pressure.
- 5) When the unit will not be used for a long time in winter, water inside the double-pipe heat exchanger and the water pipes should be drained out in case for being frozen. The water inside the double-pipe heat exchanger can be drained out by its drainage valve, the drain age valve position as Fig.3-1 display. The user can take down the front plate and open the drainage valve for water draining, and also can without taking down the front plate then use a straight screwdriver to go through the small hole in the front plate and open the drainage for water draining, the small hole position as Fig.3-5 display.
- 6) According to the different water quality the situations of double-pipe heat exchanger and water system pipelines are different. For removing the scale, it is needed to periodically clean the double-pipe heat exchanger and water system pipelines. It is suggested that set isolating valves in the suitable places during water system installation and it is convenient to connect the cleaning system for cleaning.

#### 3.6.2 Double-pipe heat exchanger cleaning

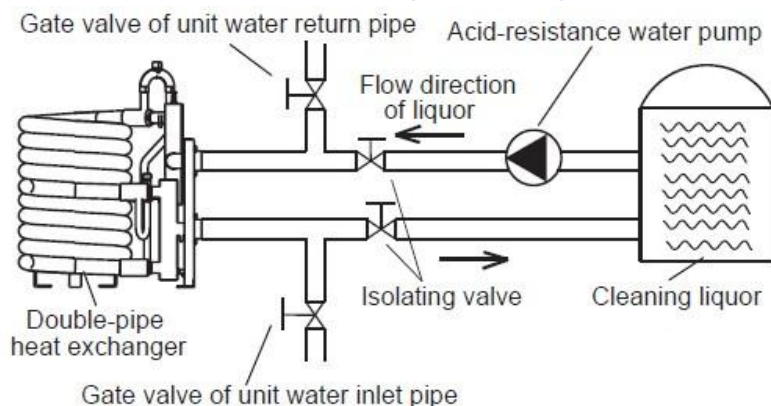

Fig.3-7 Cleaning system schematic diagram of double-pipe heat exchanger

### 3.6.2.1 Preparation of cleaning liquor:

- 1) The material of water side double-pipe is red copper, and for general corrosion situation it is suggested that use the pickle liquor with 5% oxalic acid, 1.2% buffer and 0.8% surfactant, and the temperature should be controlled in 60° C, that will has prefect cleaning effect.
- 2) If use hydrochloric acid as the cleaning liquor, for avoiding to the corrosion and shorten the working life of the heat exchanger, it should limit the concentration of the hydrochloric acid to be 3%~5%, and add corrosion inhibitor with 0.2%~0.3% concentration. When it is cleaning, pay attention to the PH value change, when the PH=8, then stop cleaning immediately. Then change to fresh water for cleaning.

### 3.6.2.2 Cleaning method:

- 1) Before connecting to the cleaning system, it must stop the unit operation, close the circulating water pump of water system, and close the gate valves in inlet and outlet water return pipes.
- 2) Correctly connect the cleaning system as the above figure 3-7, make the cleaning liquor counter flush the double-pipe heat exchanger (opposite the general flow direction).
- 3) Acid cleaning: After make sure it will not leak water, and then open the water pump to make the double-pipe heat exchanger fill with acid liquor, and close the water pump, and then let the double-pipe heat exchanger static state for 2h. And open the water pump continuously dynamic loop for 3~4h. During that every 0.5h, it is done both side alternative cleaning. During the acid cleaning, it should timely do sampling test for acid concentration, if the continuous twice testing concentration difference is lower than 0.2%, which means the acid cleaning finish reaction. Put the waste liquor to the waste liquor tank.
- 4) Neutralization: After acid cleaning, use NaOH, Na<sub>3</sub>PO<sub>4</sub> and soften liquid mixed accord to some proportion, and use dynamic loop to alkali cleaning for the heat exchanger, in order to alkalis counteract acids. Drain the waste liquor to the waste liquor tank.
- 5) Water cleaning: After alkali cleaning, use clean soften liquor repeatedly wash the heat exchanger for 0.5h, thoroughly wash the heat exchanger. Then drain the waste liquor to the waste liquor tank.
- 6) Passivating treatment : Expose the double-pipe heat exchanger in the air for 3~4h, or blow for 2h with high pressure air. Make the pipe surface form a oxidation passivating layer.
- 7) After cleaning, close the isolating valve, and take down the cleaning system devices and keeping properly for backup.
- 8) Please contact the waste liquor treating company to treat the collected waste liquor.
- 9) Connect the unit water system as the state before cleaning, thoroughly check the unit and assist devices whether work normally. Make sure there is no abnormal situation then re-operates the unit.

#### **WARNING:**

- The cleaning liquor flow direction must be correctly connected.
- Because different water quality and different using situations of the heat exchanger, the cleaning period and method will be big different, the above method is only for reference.
- The double-pipe heat exchanger is internal thread red copper pipe, so that it cannot use nitric acid as cleaning agent!
- The cleaning liquor and neutralization will be irritated and corrosive to human eyes and skin, so please do well protection measurements during the cleaning.
- It is strongly suggested that the user calls for professional cleaning company to do component analysis of the water quality and scale, and make a effective cleaning solution and method, then do the cleaning.

## **3.7 System water quality requirements and management**

3.7.1 The unit water system must select the closed cooling tower.

3.7.2 Circulating Chilled Water Processing Design Standard, other index also should meet with the Table.3-1

3.7.3 It should periodically to detect and handle the chilled water quality in the water system. When

handling the water, please make sure with the water dealing person to confirm that use any water scale inhibitor and antiseptic agent etc. will not have corrosion to the stainless steel and copper products.

Table.3-1

ITEMS	CONCENTRATION (mg/L)
Chromaticity	≤15, and cannot display other colors
Turbidity NTU	≤1
Smell	None
Visible objects	None
PH Value	7.5~9
Total hardness(Take CaCO <sub>3</sub> for calculation)	≤200
Fe	<0.5
AL	<0.2
Mn	<0.1
Cu	<0.2
Zn	≤0.1
Alkalinity concentration(HCO <sub>3</sub> <sup>-</sup> )	70~300
Sulfate radical (SO <sub>4</sub> <sup>2-</sup> )	<70
HCO <sub>3</sub> <sup>-</sup> /SO <sub>4</sub> <sup>2-</sup>	>1
Conductivity	10~500 μs/cm(20° C)
NH <sub>3</sub>	<0.1
CL	<100
Chlorine	<1
H <sub>2</sub> S	<0.05
Free carbon dioxide (CO <sub>2</sub> )	<5
Nitrate radical (NO <sub>3</sub> <sup>-</sup> )	<100
Suspended matter	≤20
Soluble solid	500~1000
Oxygen consumption (Take O <sub>2</sub> for calculation)	≤3
Ammonium ion (NH <sub>4</sub> <sup>+</sup> )	<1
SiO <sub>2</sub> (Ion state)	<50



## 4 Refrigerant Pipe Engineering

### 4.1 Length and drop height permitted of the refrigerant piping

Table.4-1

		Permitted value	piping
Pipe length	Total pipe length (Actual)	300m (Note1)	$L1+(L2+L3+L4+L5+L6+L7+L8+L9) \times 2+a+b+c+d+e+f+g+h+i+j$
	Maximum piping (L1)	Actual length	120m
		Equivalent length	150m
	Piping (farthest from the first line pipe branch) equivalent length(L2)		40m(90m,Note2)
Drop height	Indoor unit main unit drop height	Main unit up	H=50m
		Main unit down	H=40m
	Indoor unit to indoor unit drop height		H=30m

Table.4-2

No	Permitted value	Examples	Piping
1	The size of indoor unit main pipe should be bigger than the indoor unit aux. pipe. The indoor unit main pipe needn't increase when it is equal to main pipe .	L2~L9 need to increase the pipe diameter	$\phi 9.52 \rightarrow \phi 12.7$ $\phi 12.7 \rightarrow \phi 15.9$ $\phi 15.9 \rightarrow \phi 19.1$ $\phi 19.1 \rightarrow \phi 22.2$ $\phi 22.2 \rightarrow \phi 25.4$ $\phi 25.4 \rightarrow \phi 28.6$ $\phi 28.6 \rightarrow \phi 31.8$ $\phi 31.8 \rightarrow \phi 38.1$ $\phi 38.1 \rightarrow \phi 41.3$
2	The length of indoor unit aux. pipe is no longer than 40m.	$a,b,\dots,j \leq 40m$ .	Reference Fig.1-1
3	The distance difference between [the main unit to the farthest indoor unit] and [the main unit to the nearest indoor unit] is $\leq 40m$ .	If the farthest indoor unit is N10, the nearest indoor unit is N1, i.e. $(L1+L5+L8+L9+j) - (L1+L2+L3+a) \leq 40m$ .	

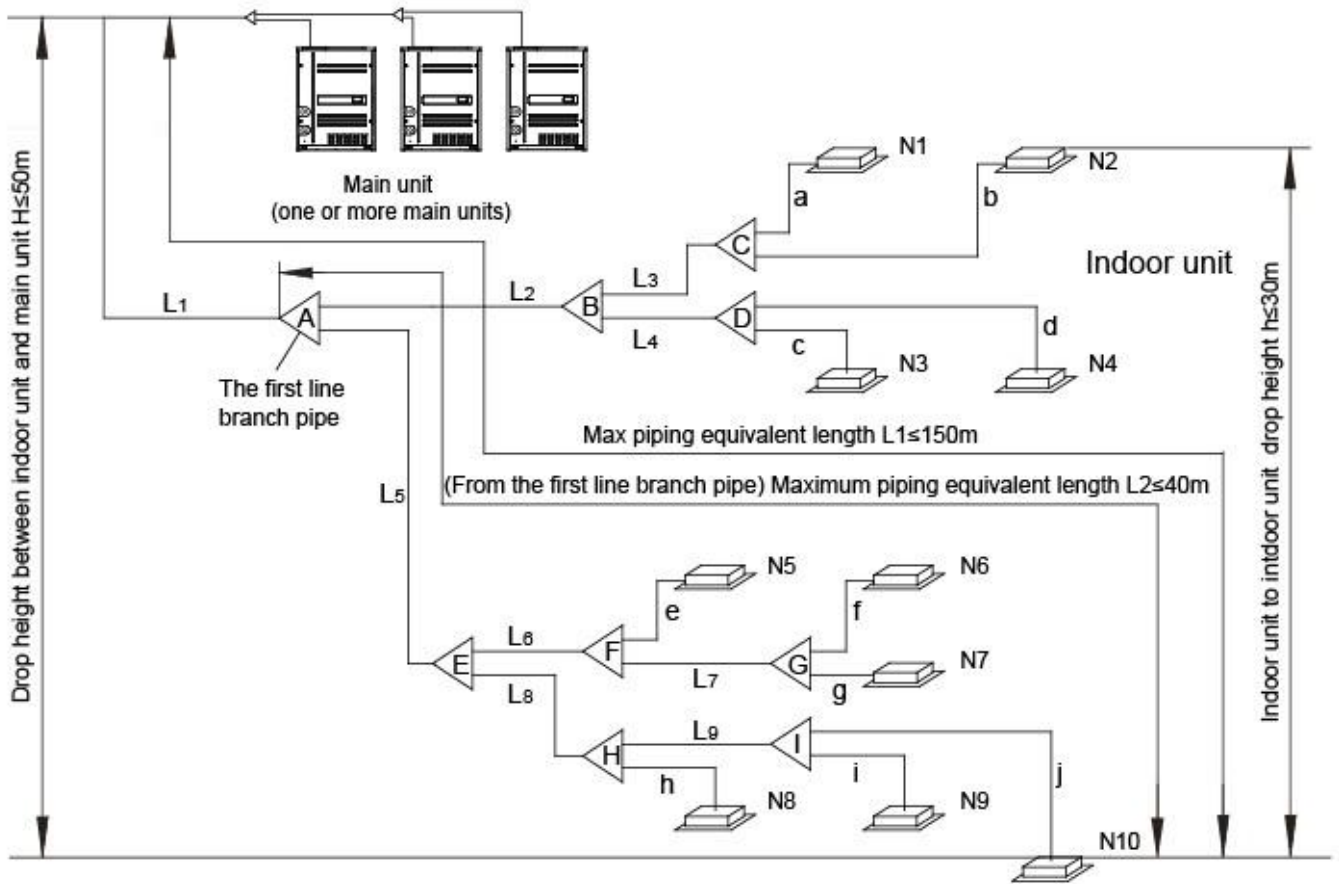

Fig.4-1

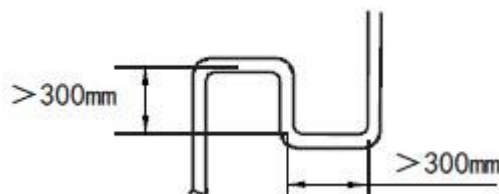

Fig.4-2

**CAUTION:**

1. All branch pipes must apply the branch pipes specified by Midea, otherwise, that will cause serious error of the system!
2. Indoor units should be placed as equally as possible at the both sides of the U-shape branch pipe.
3. When the main unit is over 20m from the above places, it is recommended to set a return oil bending every 10m of the air pipe in the main pipe, the return oil bending specification is as Fig. 4-2.

### 4.2 Select the Refrigerant Piping Type

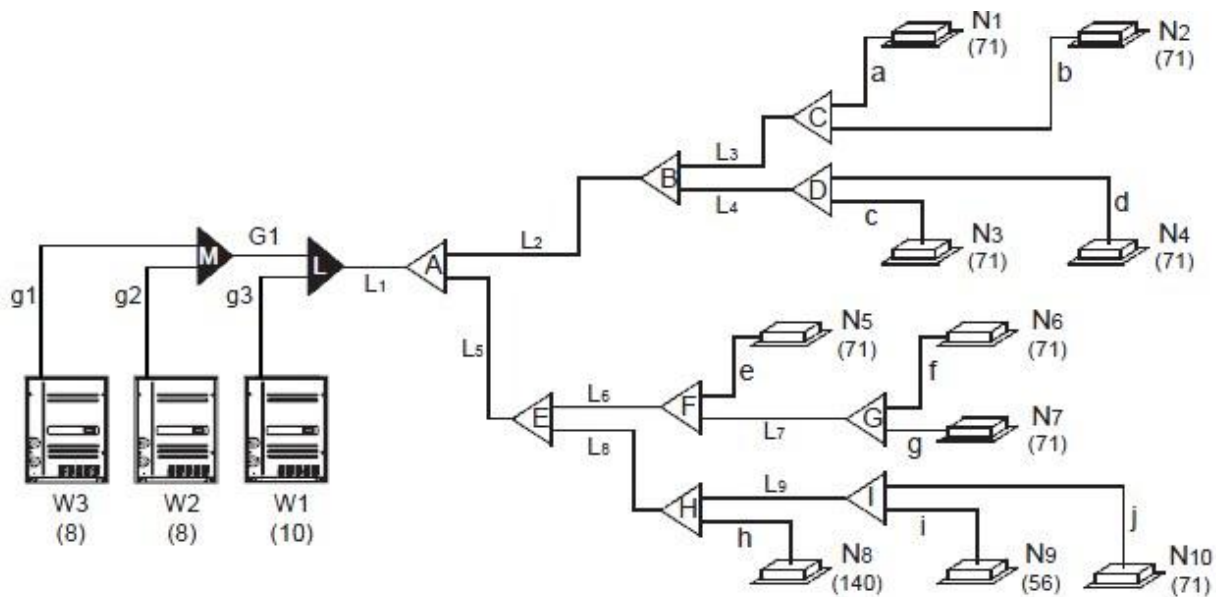

Fig.4-3

Table.4-3

Pipe name	Code (As per the Fig. 4-2)
Main pipe	L1
Indoor unit main pipe	L2~L9
Indoor unit aux. pipe	a, b, c, d, e, f, g, h, i, j
Indoor unit branching pipe assembly	A, B, C, D, E, F, G, H, I
Main unit branching pipe assembly	L, M
Main unit connective pipe	g1, g2, g3, G1

### 4.3 Size of joint pipes for indoor unit

Capacity of indoor unit (A)	Size of main pipe(mm)		Available branching pipe
	Gas side	Liquid side	
A < 166	Φ 15.9	Φ 9.5	FQZHN-01C
166 ≤ A < 230	Φ 19.1	Φ 9.5	FQZHN-01C
230 ≤ A < 330	Φ 22.2	Φ 9.5	FQZHN-02C
330 ≤ A < 460	Φ 28.6	Φ 12.7	FQZHN-03C
460 ≤ A < 660	Φ 28.6	Φ 15.9	FQZHN-03C
660 ≤ A < 920	Φ 31.8	Φ 19.1	FQZHN-03C
920 ≤ A < 1350	Φ 38.1	Φ 19.1	FQZHN-05C

e.x.1: Refer to Fig.4-2 , the capacity of downstream units to L2 is 71 × 4=284, i.e. the gas pipe for L2 is Φ 22.2, liquid pipe is Φ 9.5.

### 4.4 Size of joint pipes for main unit

Base on the following tables, select the diameters of the main unit connective pipes. In case of the main accessory pipe large than the main pipe, take the large one for the selection.

Example: parallel connect with the three main units 10+10+8 (the total capacity is 28HP), all indoor units total capacity is 812,provided that the equivalent length of all pipes are ≥90m, according to the Table 4-3 the main pipe diameter are Φ 31.8/Φ 22.2; in according to all indoor unit capacity 1360, we could find out the master unit diameter is Φ 31.8/Φ 19.1 base on Table 4-6. Take the large one for the selection, we

final confirm the main pipe diameter is  $\Phi 38.1/\Phi 22.2$ .

Table.4-5 Size of joint pipes for 410A main unit

Model	When the equivalent length of all liquid pipes < 90m, the size of main pipe(mm)		
	Gas side	Liquid side	The 1st branching pipe
8HP	$\Phi 22.2$	$\Phi 9.5$	FQZHN-02C
10HP	$\Phi 22.2$	$\Phi 9.5$	FQZHN-02C
12HP	$\Phi 25.4$	$\Phi 12.7$	FQZHN-02C
16HP	$\Phi 28.6$	$\Phi 12.7$	FQZHN-03C
18~22HP	$\Phi 28.6$	$\Phi 15.9$	FQZHN-03C
24HP	$\Phi 28.6$	$\Phi 15.9$	FQZHN-03C
26~32HP	$\Phi 31.8$	$\Phi 19.1$	FQZHN-03C
34~36HP	$\Phi 38.1$	$\Phi 19.1$	FQZHN-04C

Table.4-6 Size of joint pipes for 410A main unit

Model	When the equivalent length of all liquid pipes $\geq 90m$ , the size of main pipe(mm)		
	Gas side	Liquid side	The 1st branching pipe
8HP	$\Phi 22.2$	$\Phi 12.7$	FQZHN-02C
10HP	$\Phi 25.4$	$\Phi 12.7$	FQZHN-02C
12HP	$\Phi 28.6$	$\Phi 15.9$	FQZHN-03C
16HP	$\Phi 31.8$	$\Phi 15.9$	FQZHN-03C
18~22HP	$\Phi 31.8$	$\Phi 19.1$	FQZHN-03C
24HP	$\Phi 31.8$	$\Phi 19.1$	FQZHN-03C
26~32HP	$\Phi 38.1$	$\Phi 22.2$	FQZHN-04C
34~36HP	$\Phi 38.1$	$\Phi 22.2$	FQZHN-04C

### 4.5 Branch pipes for main unit

Table.4-7

Model	Main unit pipe connective opening dimension(mm)	
	Gas side	Liquid side
8HP, 10HP	$\Phi 25.4$	$\Phi 12.7$
12HP	$\Phi 31.8$	$\Phi 15.9$

### 4.6 Branch pipes for indoor unit

Base on Table 4-8 and Table 4-9 select the multi connecting pipes of main unit. Before installation, please read the Main unit Branching Pipe Installation Manual carefully.

Table.4-8 Main unit multi-connective pipe assembly (Illustration)

Main unit Qty.	Illustration
2 units	
3 units	

Table.4-9 Main unit multi-connective pipe assembly

Main unit Qty.	Main unit connective pipe diameter	Parallel connect with the branching pipes	Main pipe
2 units	g1, g2: 8, 10HP: $\Phi 25.4/\Phi 12.7$ ; 12HP: $\Phi 31.8/\Phi 15.9$	L: FQZHW-02N1C	Refer to Table 6-5 for main pipe dimension
3 units	g1, g2, g3: 8, 10HP: $\Phi 25.4/\Phi 12.7$ ; 12HP: $\Phi 31.8/\Phi 15.9$ ; G1: $\Phi 38.1/\Phi 19.1$	L+M: FQZHW-03N1C	

Note: The pipe assemblies in above table is special for this model, must be purchased separately

#### 4.7 Example

- 1) Take (10+8+8) HP that composed by three modules as an example to clarify the pipe selection.
- 2) Take Fig.4-4 as an example. Provided that the equivalent length of all pipes in this system is larger than 90m.

Table.4-10

Unit: mm

Indoor unit capacity A( $\times 100W$ )	When branching Pipe's length $\leq 10m$		When branching Pipe's length $> 10m$	
	Gas side	Liquid side	Gas side	Liquid side
$A \leq 45$	$\Phi 12.7$	$\Phi 6.4$	$\Phi 15.9$	$\Phi 9.5$
$A \geq 56$	$\Phi 15.9$	$\Phi 9.5$	$\Phi 19.1$	$\Phi 12.7$

A. The branching pipe at the inside of the unit. There are a~j branching pipes at the inside of the unit, the branching pipe diameter should be select as per Table 4-10.

B. Main pipe at the inside the unit (Refer to Table 1-4)

- 1) The main pipe L3 with N1, N2 downstream indoor units that total capacity is  $71 \times 2 = 142$ , the pipe L3 diameter is  $\Phi 15.9/\Phi 9.5$ , thus select FQZHN-01C for the branching pipe C.
- 2) The main pipe L4 with N3, N4 downstream indoor units that total capacity is  $71 \times 2 = 142$ , the pipe L3 diameter is  $\Phi 15.9/\Phi 9.5$ , thus select FQZHN-01C for the branching pipe D.
- 3) The main pipe L2 with N1~N4 downstream indoor units that total capacity is  $71 \times 4 = 284$ , the pipe L2 diameter is  $\Phi 22.2/\Phi 9.5$ , thus select FQZHN-02C for the branching pipe B.
- 4) The main pipe L7 with N6, N7 downstream indoor units that total capacity is  $56 + 71 = 127$ , the pipe L7 diameter is  $\Phi 15.9/\Phi 9.5$ , thus select FQZHN-01C for the branching pipe G.
- 5) The main pipe L6 with N5~N7 downstream indoor units that total capacity is  $56 + 71 \times 2 = 282$ , the pipe L6 diameter is  $\Phi 19.1/\Phi 9.5$ , thus select FQZHN-01C for the branching pipe F.
- 6) The main pipe L9 with N9, N10 downstream indoor units that total capacity is  $56 \times 2 = 112$ , the pipe L9 diameter is  $\Phi 15.9/\Phi 9.5$ , thus select FQZHN-01C for the branching pipe I.
- 7) The main pipe L8 with N8~N10 downstream indoor units that total capacity is  $112 + 56 \times 2 = 224$  the pipe L8 diameter is  $\Phi 19.1/\Phi 9.5$ , thus select FQZHN-01C for the branching pipe H.
- 8) The main pipe L5 with N5~N10 downstream indoor units that total capacity is  $112 + 56 \times 3 + 71 \times 2 = 366$ , the pipe L5 diameter is  $\Phi 28.6/\Phi 12.7$ , thus select FQZHN-03C for the branching pipe E.
- 9) The main pipe A with N1~N10 downstream indoor units that total capacity is  $56 \times 3 + 71 \times 6 + 112 = 706$ , thus select FQZHN-03C for the branching pipe A.

C Main pipe (Refer to Table 5-4, Table 5-5, Table 5-6): Main pipe L1 in the Fig.6-2, which upstream main units total capacity is  $10 + 8 + 8 = 26HP$ , base on table 6-5, the gas/liquid pipe diameter are  $\Phi 38.1/\Phi 22.2$ , total capacity of the downstream indoor unit is  $56 \times 3 + 71 \times 6 + 112 = 706$ , base on table 5-4, the gas/liquid

pipe diameter are  $\Phi 31.8/\Phi 19.1$ , take the large one for your selection, final confirm the main pipe diameter is: gas/liquid pipe  $\Phi 38.1/\Phi 22.2$ .

D Parallel connect the main units

- 1) The main unit linked by Pipe g1 is 8HP, parallel connects with main unit. the connective pipe diameter to be selected according to its connector size is  $\Phi 25.4/\Phi 12.7$ ;The main unit linked by Pipe g2 is 8HP, parallel connects with main unit. the connective pipe diameter to be selected according to its connector size is  $\Phi 25.4/\Phi 12.7$ ;The main unit linked by Pipe g3 is 10HP, parallel connects with main unit. the connective pipe diameter to be selected according to its connector size is  $\Phi 25.4/\Phi 12.7$ .
- 2) The upstream of G1 is the two parallel connected main units, refer to Table 5-9 select the three parallel connected main unit, the pipe diameter is  $\Phi 38.1/\Phi 19.1$ .
- 3) Parallel connect the three main units, refer to Table 5-7 should select FQZHW-03N1C for main unit connective pipes (L+M).

**4.8 Remove dirt or water in the piping**

1. Make sure there is no any dirt or water before connecting the piping to the main units.
2. Wash the piping with high pressure nitrogen, never use refrigerant of the main unit.

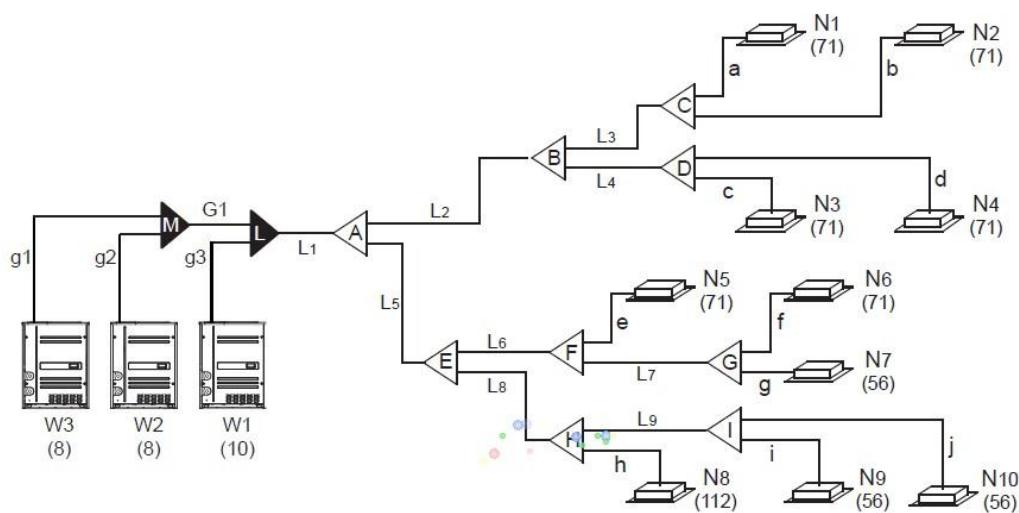

**4.9 Gas tight test**

- 1) Upon set up the indoor unit pipeline, please connect the Hi-pressure pipe with shut-off valve firstly.
- 2) Weld the pipe at the low pressure side to the meter connector.
- 3) Use the vacuum pump discharging air inside the liquid side shut-off valve and meter connector, until to the -0.1MPa.
- 4) Close the vacuum pump, charge 3.9MPa nitrogen gas from the piston of shut-off valve and from the meter connector. Pressure inside should be maintained at there no less than 24 hrs.

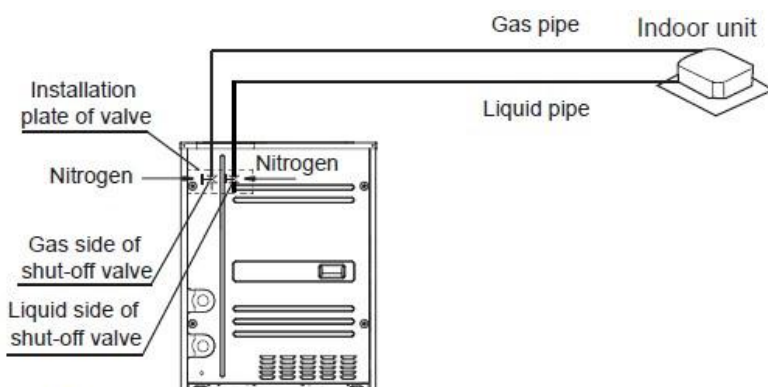

**CAUTION:**

1. Pressurized nitrogen (3.9MPa) is used for air tightness test.
2. It is not allow to use oxygen, combustibile gas or toxic gas to conduct the air tightness test.
3. When welding, please use wet cloth insulating the low pressure valve for protection.
4. For avoid the equipment be damaged, the pressure maintained time should not last too long.

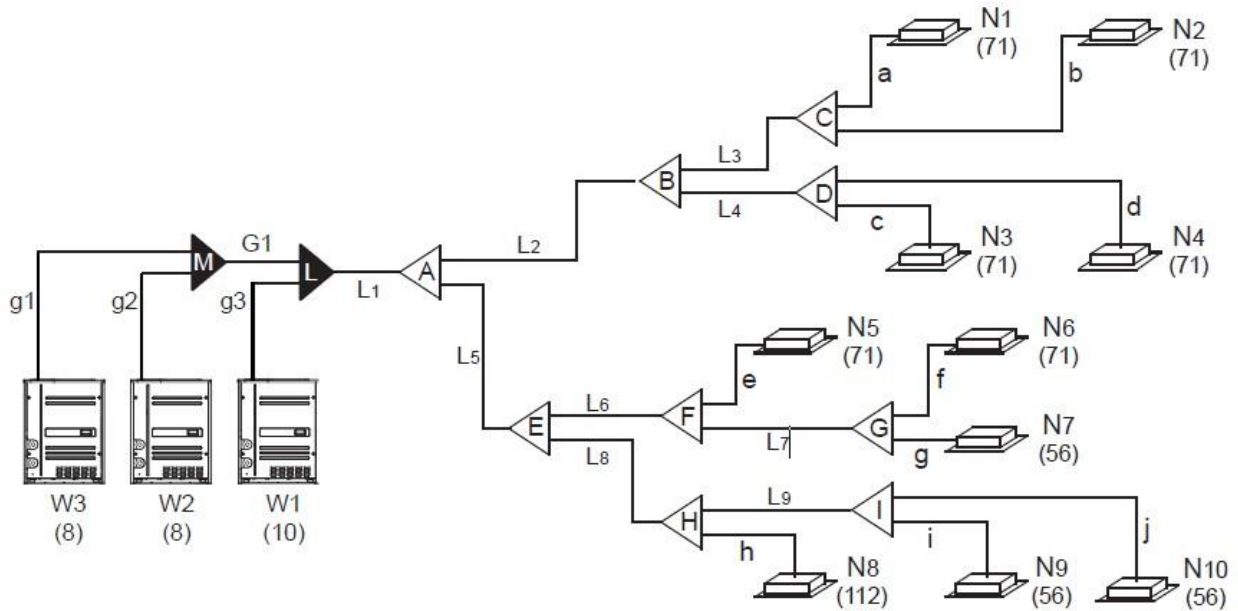

**4.10 Vacuum with vacuum pump**

1. Use the vacuum pump which vacuum level lower than -0.1MPa and the air discharge capacity above 40L/min.
2. The main unit is not necessary to vacuum, don't open the main unit gas and liquid pipe shut-off valves.
3. Make sure the vacuum pump could result as -0.1MPa or below after 2 hrs or above operation. If the pump operated 3 hrs or above could not achieve to -0.1MPa or below, please check whether water mix or gas leak inside of the pipe.

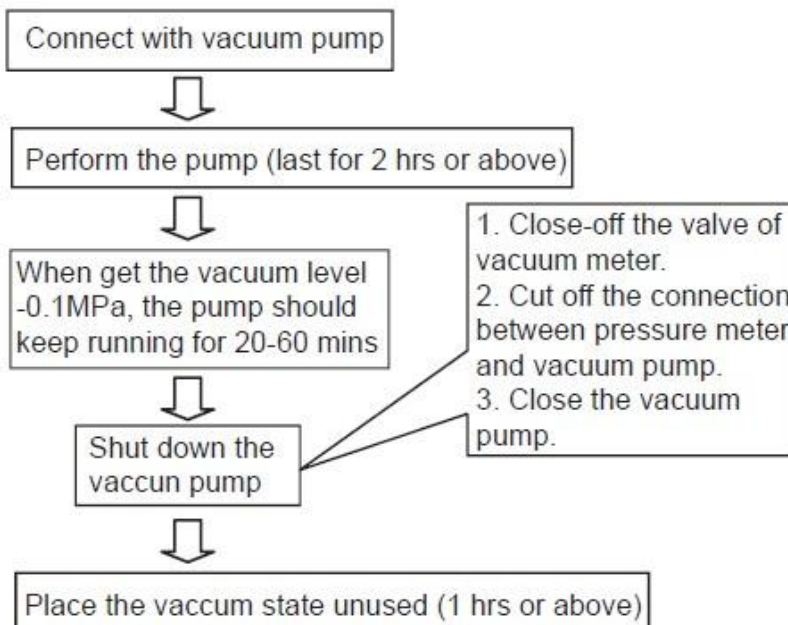



**CAUTION:**

1. Don't mix up the different refrigerants or abuse the tools and measurements which directly contact with refrigerants
2. Don't adopt refrigerant gas for air vacuuming.
3. If vacuum level could not get to -0.1MPa, please check whether resulted by leakage and confirm the leakage site. If no leakage, please operate the vacuum pump again 1 or 2 hrs.

Calculate the added refrigerant according to the diameter and the length of the liquid side pipe of the main/indoor unit connection. The refrigerant is R410A.

Table.4-11

Pipe size on liquid side	Refrigerant to be Added per meter
Φ 6.4	0.022kg
Φ 9.5	0.057kg
Φ 12.7	0.110kg
Φ 15.9	0.170kg
Φ 19.1	0.260kg
Φ 22.2	0.360kg
Φ 25.4	0.520kg
Φ 28.6	0.680kg

**4.11 The Installation key points of connective pipes between main units**

- 1) Connect the pipes between main units, the pipes should place horizontally (Fig.5-7, Fig.5-8), it is not allow the concave at junction site and set longer than 200mm bending pipes for saving oil.
- 2) All connective pipes between the main units are not allowed to over than the height of every outlets of the pipes(Refer to Fig.5-9, Fig.5-10).

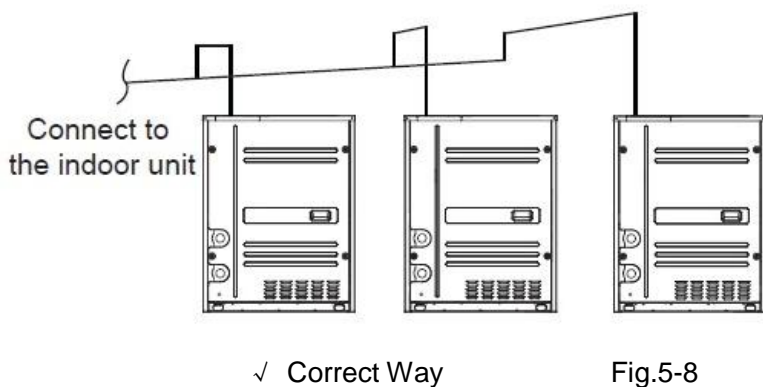
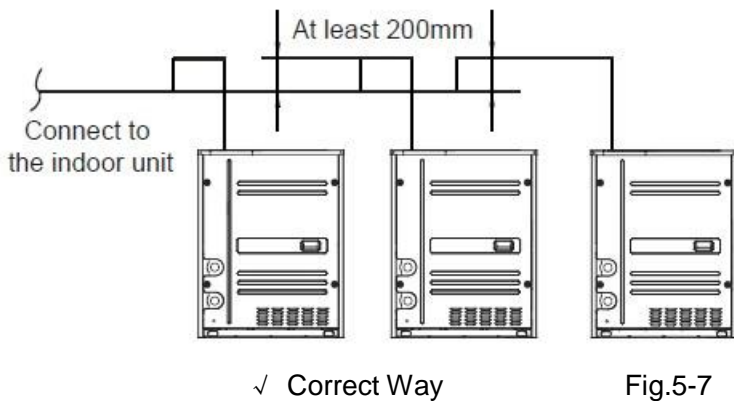

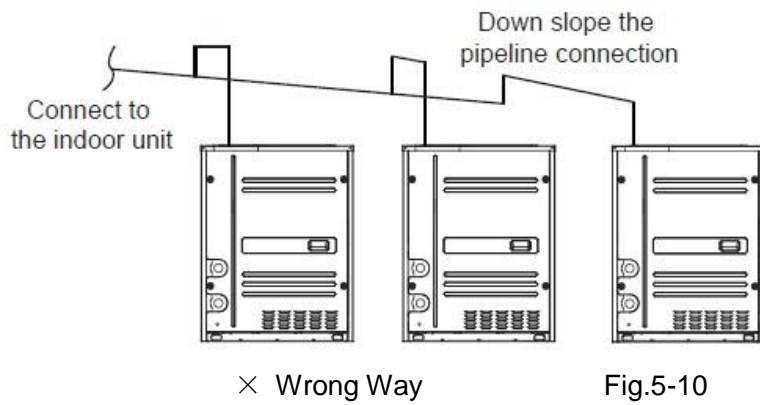
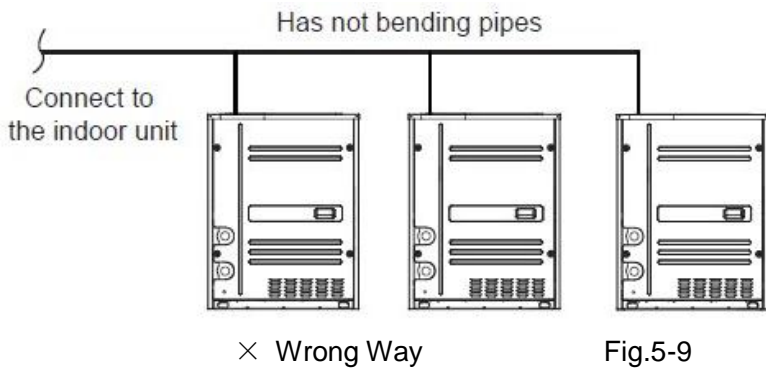

3) The branching pipe must be installed horizontally, error angle of it should not large than  $10^\circ$  . Otherwise, malfunction will be caused.

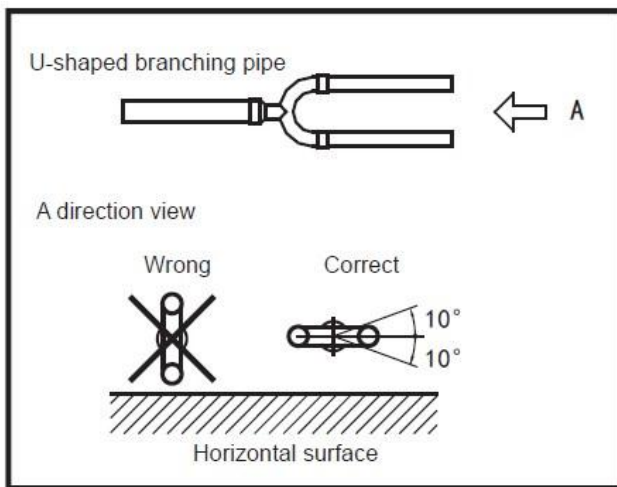

Fig.5-11

## 5. TRIAL RUN

### 5.1 Inspection and confirmation before commissioning

- 1) Check and confirm that refrigeration pipe line and communication wire with indoor and main unit have been connected to the same refrigeration system. Otherwise, operation troubles shall happen.
- 2) Power voltage is within  $\pm 10\%$  of rated voltage.
- 3) Check and confirm that the power wire and control wire are correctly connected.
- 4) Before powering on, confirm there is no short circuit to each line.
- 5) Check whether all units have passed nitrogen pressure-keeping test for 24 hours with R410A: 40kg/cm<sup>2</sup> .
- 6) Confirm whether the system to debugging has been carried out vacuum drying and packed with refrigeration as required.
- 7) Make sure all the water pipelines are correct, including the installation directions of water filter and water flow switch.
- 8) Check whether the water filter has been blocked, and clean the filter screen. If it is seriously blocked, then it should be checked whether the water quality has meet the requirements.
- 9) Open the gate valve, make sure the double-pipe heat exchanger have been filled with circulating water, and open the water pump and air discharge valve, after make sure the air in the water pipelines and unit has been drain out and then close the air discharge valve.
- 10) Check whether the pressure meters in the water inlet and water return pips of the unit, thermometer, water flow switch etc. work normally, and make sure the water pipelines system operate normal, and the water flow is suitable.

### 5.2 Preparation before debugging

- 1) Calculating the additional refrigerant quantity for each set of unit according to the actual length of liquid pipe.
- 2) Keep required refrigerant ready.
- 3) Keep system plan, system piping diagram and control wiring diagram ready.
- 4) Record the setting address code on the system plan.
- 5) Turn on power switches main unit in advance, and keep connected for above 12 hours so that heater heating up refrigerant oil in compressor.
- 6) Turn on air pipe stop valve, liquid pipe stop valve, oil balance valve and air balance valve totally. If the above valves do not be turned on totally, the unit should be damaged.
- 7) Check whether the power phase sequence of main unit is correct.
- 8) All dial switch to indoor and main unit have been set according to the Technical Requirement of Product.

### 5.3 Fill the name of connected system

To clearly identify the connected systems between two or more indoor units and main unit, select names for every system and record them on the nameplate on the outdoor electric control box cover.

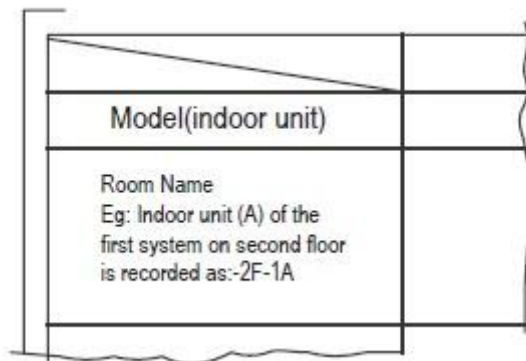

Fig.6-1

**5.4 Caution on refrigerant leakage**

- 1) This air conditioner adopts R410A as refrigerant, which is safe and noncombustible.
- 2) The room for air conditioner should be big enough that refrigerant leakage can not reach the critical thickness. Besides this, you can take some action on time.
- 3) Critical thickness-----the max thickness of Freon without any harm to person. R410A critical thickness: 0.3 [kg/m3]

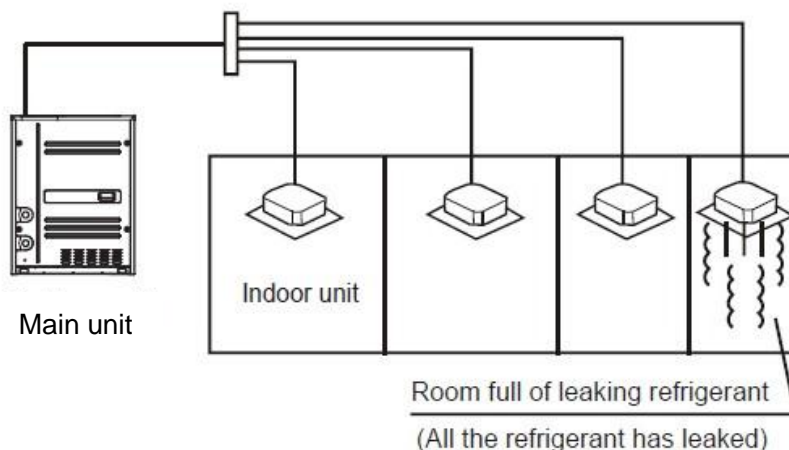

Fig.6-2

- 4) Calculate the critical thickness through following steps, and take necessary actions.
  - Calculate the sum of the charge volume (A[kg]) total refrigerant volume=refrigerant volume when delivered (nameplate)+super addition
  - Calculate the indoor cubage (B[m3]) (as the minimum cubage)
  - Calculate the refrigerant thickness.

$$\frac{A[\text{kg}]}{B[\text{m}^3]} \leq \text{Critical thickness: } 0.3 [\text{kg}/\text{m}^3]$$

5. Counter measure against over high thickness

- Install mechanical ventilator to reduce the refrigerant thickness under critical level. (ventilate regularly)
- Install leakage detector alarming device related to mechanical ventilator if you can not regularly ventilate.

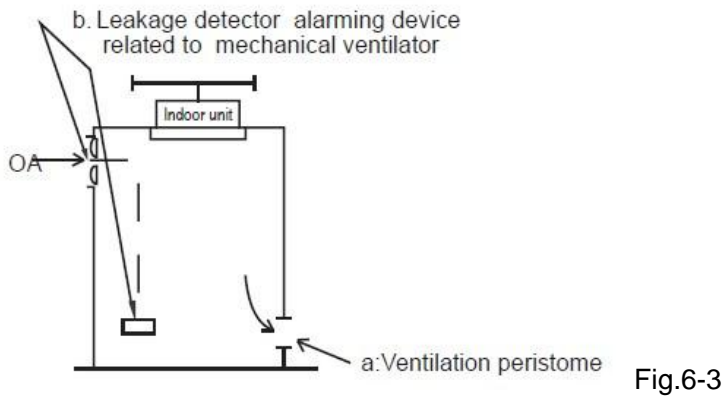

## Commissioning Report for Midea MDV Pro System

Date:dd mm yy

<b>Item name:</b>	
<b>Address:</b>	<b>Tel:</b>
<b>Supplier:</b>	<b>Delivery date: dd mm yy</b>
<b>Installation section:</b>	<b>Principal:</b>
<b>Commissioning section:</b>	<b>Principal:</b>
<b>Remark: recharged refrigeration quantity to system: kg</b>	
<b>Name of refrigerant:</b>	<b>(R22, R407C, R410A)</b>

Installing section:  
(seal)

Commissioning name:  
(seal)

Signature:

Signature:

Date: \_\_\_\_dd\_\_\_\_mm\_\_\_\_yy

Date: \_\_\_\_dd\_\_\_\_mm\_\_\_\_yy

## Test Data for Test Run of \_\_\_\_\_ System

<b>Model of main unit</b>	<b>Production series no.</b>

### Operation data of main unit (Cooling)

Unit	No.1	No.2	No.3
Run Voltage V			
Total current of run A			
Operation current of compressor A			
High-pressure pressure Kg/cm <sup>2</sup>			
Low-pressure pressure Kg/cm <sup>2</sup>			
Inlet air temperature °C			
Outlet air temperature °C			

### Operation data of indoor unit

No.	Position	Model	Bar code of indoor unit	Inlet air temperature °C	Outlet air temperature °C
1					
2					
3					
4					
5					
6					
7					
8					
9					
10					
11					
12					
13					
14					
15					
16					



**System parameter****SW1:**

(CHECK)——Used to query main unit data. Check point sequence and corresponding actuality is as follows:

No.	Display content	Note	No.	Display content	Remark
1	Main unit address	0,1,2,3	14	TSC1, water outlet temp. of upper pipe	Actual value
2	Capacity of main unit	8,10,12	15	TSC2, water outlet temp. of lower pipe	Actual value
3	Qty. of modular main unit	Effective to master unit	16	Current 1 of inverter compressor	Actual value
4	Total capacity of main unit	Capacity requirement	17	Current 2 of inverter compressor	Actual value
5	Total capacity requirement of indoor unit	Effective to master unit	18	High pressure	Actual value
6	Total capacity requirement of master unit after correction	Effective to master unit	19	Low pressure	Actual value
7	Operation mode	0,2,3,4	20	Opening degree of EEV A	Display value ×8
8	The actual operation capacity of main unit	Capacity requirement	21	Opening degree of EEV B	Display value ×8
9	Water flow switch	0-OFF,1-ON	22	Priority mode	0,1,2,3,4
10	T2B/T2 average temp.	Actual value	23	Quantity of communicated indoor units	Actual value
11	T5, inverter module temp.	Actual value	24	The qty. of installed indoor units	Actual value
12	T7, discharge temp. of inverter compressor	Actual value	25	The last time error or protective code	Without protection or error display code 00
13	TSJ, water inlet temp.	Actual value	26	——	Check end

Normal display:

- When in standby mode, it displays number of indoor units that can communicate with outdoor unit. When it is operating, it will display the rotation frequency of the compressor.
- Operating mode: 0---Off/Fan; 1---fan only; 2---Cooling; 3---Heating; 4---Forced cooling
- Water flow switch state:0---close;1---open.
- Priority mode:0---Heating priority mode;1---Cooling priority mode;2---Priority mode;3---Only respond the heating mode; 4---Only respond the cooling mode
- EXV opening angle: pulse count=display value×8. ENC1: Outdoor unit address setting switch,
- ENC1: Main unit address setting switch.  
ENC2: Main unit capacity setting switch.  
ECN3: Network address setting switch.  
S10, ENC4: combination setting the qty. of the installed indoor units.  
SW1: Query button;SW2:Constraint cooling.

Note: Setting 0 or 1, all mean install 1 set indoor unit.