

Contents

Part 1	General Information	1
Part 2	Outdoor Units	5
Part 3	Installation.....	80

Manufacture reserves the right to discontinue, or change at any time, specifications or designs without notices and without incurring obligations.

Part 1 General Information

1. Product Lineup	2
2. Nomenclature.....	3
3. Features.....	4

1. Product Lineup

Outdoor Units

MDV-V80W/N1	MDV-V105W/N1-B MDV-V105W/BDRN1
	
MDV-V105W/N1 MDV-V140W/N1 MDV-V140W/BDRN1 MDV-V160W/BDRN1	
	

Model name	Dimension (mm) Width*Height*Depth	Net/Gross weight (kg)	Power supply
MDV-V80W/N1	895*862*355	66/70	220-240V~50Hz
MDV-V105W/N1	940*1245*360	108/116	220-240V~50Hz
MDV-V105W/N1-B	990*966*354	78/89	220-240V~50Hz
MDV-V140W/N1	940*1245*360	108/116	220-240V~50Hz
MDV-V105W/BDRN1	990*966*354	104/111	380~415V-3ph-50Hz
MDV-V140W/BDRN1	940*1245*360	115/121	380~415V-3ph-50Hz
MDV-V160W/BDRN1-B	940*1245*360	125/138.5	380~415V-3ph-50Hz

2. Nomenclature

MDV – V 105 W / B D R N1-B

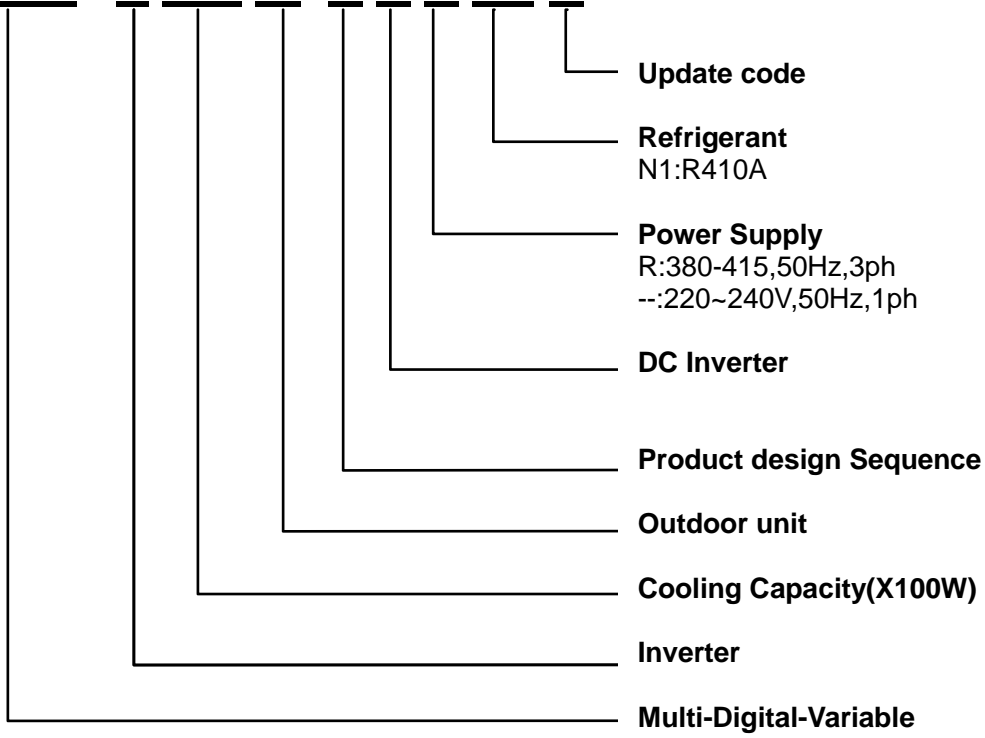

3. Features

1. From 2.2kW to 16kW with different type indoor units, it is full compliance with residential and light commercial place.
2. Only two main refrigerant lines (liquid pipe and gas pipe) are required in one system.
3. In some large residential spaces or some light commercial space, such as villa, restaurant, usually it need more than one indoor unit, so outside the building are also full of outdoor unit. Now Midea can provide an effective solution-Midea DC inverter mini system. Since now the beauty of the building will be back.

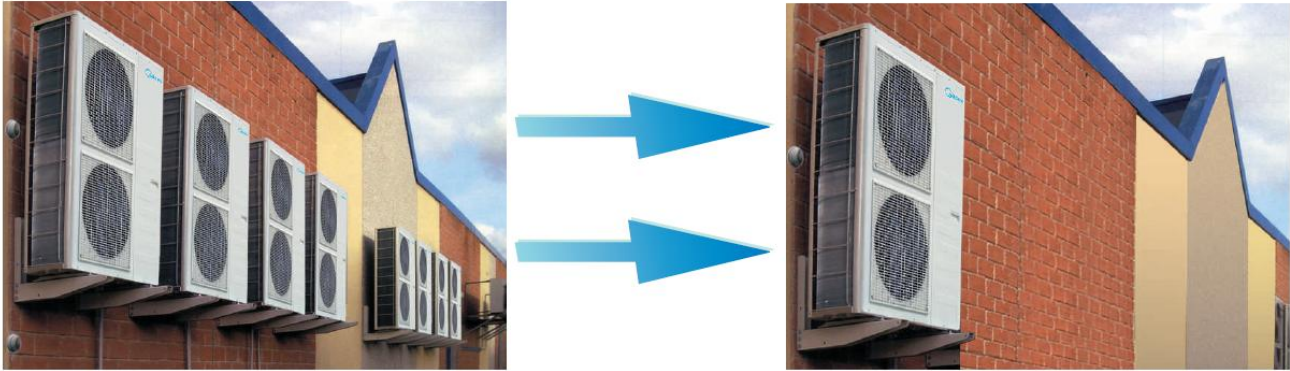

4. Indoor unit is over 50 models in 8 type variations can be choose, including 4-way cassette, 4-way cassette(Compact), duct, ceiling and floor, wall-mounted, floor-standing, give you the most fashionable and comfortable living space.
5. The outdoor unit can be used as unitary type outdoor unit or multi type outdoor unit. So there can be only one indoor unit matched with outdoor unit.
6. Indoor unit is the same as the inverter smart series, please refer to the inverter smart part.

Part 2 Outdoor Units

1. Specifications.....	6
2. Dimensions.....	9
3. Service Space.....	10
4. Piping Diagrams.....	11
5. Wiring Diagrams.....	12
6. Field Wiring	17
7. Capacity Tables	19
8. Electric Characteristics	55
9. Sound Levels.....	56
10. Operation Limits.....	57
11. Troubleshooting	58

1. Specifications

Sale Model			MDV-V80W/N1	MDV-V105W/N1	
Power supply		V-ph-Hz	220-240, 1, 50	220-240, 1, 50	
Cooling	Capacity	kW	8	10.5	
	Input	kW	2.56	3.26	
Heating	Capacity	kW	9	12.2	
	Input	W	2.71	3.38	
Max. input consumption		W	3766	5216	
Max. current		A	17.3	25.4	
Compressor	Model		TNB220FLHMC	TNB306FPGM	
	Type		Rotary	Rotary	
	Brand		MITSUBISHI	MITSUBISHI	
	Supplier		MITSUBISHI	MITSUBISHI	
	Capacity	Btu/h	24334	34100	
	Input	W	2200	3080	
	Rated current(RLA)	A	9.7	13.5	
	Refrigerant oil	ml	PVE 670ml	FV50S, 870	
Outdoor fan motor	Model		YDK75-6H-1	YDK100-6A(×2)	
	Brand		Welling	Welling	
	Input	W	168	185/120(×2)	
	Capacitor	uF	5	3.5uF/450V	
	Speed	r/min	877	860/610	
Outdoor coil	Number of rows		2	3	
	Tube pitch(a)x row pitch(b)	mm	22*19.05	25.4×22	
	Fin spacing	mm	1.7	1.5	
	Fin type (code)		Hydrophilic Aluminum	Hydrophilic aluminum	
	Tube outside dia.and type	mm		Φ7.94	Φ9.53
				Inner groove tube	Inner groove tube
	Coil length x height x width	mm	766*792*38.1	887×1220×66	
Number of circuits		8	8		
Outdoor air flow		m ³ /h	5966/4775	6500/4800	
Sound level (sound pressure)		dB(A)	57/54	57/54	
Outdoor unit	Dimension(WxHxD)	mm	895*862*355	940×1245×360	
	Packing (WxHxD)	mm	1043*915*395	1058×1380×438	
	Net/Gross weight	kg	66/70	108/116	
Refrigerant	Type		R410A	R410A	
	Charged volume	g	2800	4200	
Throttle type			Electronic expansion valve	Electronic expansion valve	
Design pressure		MPa	4.4/2.6	4.2/2.6	
Refrigerant piping	Liquid side/ Gas side	mm	Φ9.53/Φ15.9	Φ9.53/Φ15.9	
	Max. refrigerant pipe length	m	100	100	
	Max. difference in level	m	20	20	
Connection wiring	Power wiring	mm ²	3 core×4	3 core×4	
	Signal wiring	mm ²	3 core shielded wire, 3×0.5	3 core shielded wire, 3×0.5	
Ambient temp.		°C	(Cooling -15~43)(Heating -15~21)		
Application area		m ²	30~52.5	52.5~70	

Sale Model			MDV-V105W/N1-B	MDV-V140W/N1	
Power supply		V-ph-Hz	220-240, 1, 50	220-240, 1, 50	
Cooling	Capacity	kW	10.5	14	
	Input	kW	3.26	4.36	
Heating	Capacity	kW	12.2	15	
	Input	W	3.38	4.13	
Max. input consumption		W	4757	5770	
Max. current		A	19.6	27.1	
Compressor	Model		TNB220FLHMC	TNB306FPGM	
	Type		Rotary	Rotary	
	Brand		Mitsubishi	Mitsubishi	
	Supplier		Mitsubishi	Mitsubishi	
	Capacity	Btu/h	24350	34100	
	Input	W	2200	3080	
	Rated current(RLA)	A	9.7	13.5	
	Refrigerant oil	ml	FV50S, 870	FV50S, 870	
Outdoor fan motor	Model		YDK190-6E	YDK100-6A(×2)	
	Brand		Welling	Welling	
	Input	W	269	185/120(×2)	
	Capacitor	uF	10uF/450V	3.5uF/450V	
	Speed	r/min	800/636	860/610	
Outdoor coil	Number of rows		2	3	
	Tube pitch(a)x row pitch(b)	mm	22×19.05	25.4×22	
	Fin spacing	mm	1.7	1.5	
	Fin type (code)		Hydrophilic aluminum	Hydrophilic aluminum	
	Tube outside dia.and type	mm		Φ7.94	Φ9.53
				Inner groove tube	Inner groove tube
	Coil length x height x width	mm	885×880	887×1220×66	
Number of circuits		5	8		
Outdoor air flow		m ³ /h	5300	6500/4800	
Sound level (sound pressure)		dB(A)	57/54	57/54	
Outdoor unit	Dimension(WxHx D)	mm	990×966×354	940×1245×360	
	Packing (WxHx D)	mm	1120×1100×435	1058×1380×438	
	Net/Gross weight	kg	78/89	108/116	
Refrigerant	Type		R410A	R410A	
	Charged volume	g	3000	4800	
Throttle type			Electronic expansion valve	Electronic expansion valve	
Design pressure		MPa	4.4/2.6	4.2/2.6	
Refrigerant piping	Liquid side/ Gas side	mm	Φ9.53/Φ15.9	Φ9.53/Φ15.9	
	Max. refrigerant pipe length	m	100	100	
	Max. difference in level	m	20	20	
Connection wiring	Power wiring	mm ²	3 core×4	3 core×4	
	Signal wiring	mm ²	3 core shielded wire, 3×0.5	3 core shielded wire, 3×0.5	
Ambient temp.		℃	(Cooling -15~43)(Heating -15~21)		
Application area		m ²	52.5~70	70~93	

Sale Model			MDV-V105W/BDRN1	MDV-V140W/BDRN1	MDV-V160W/BDRN1-B
Power supply		V-Ph-Hz	380~415-3 -50	380~415-3 -50	380~415-3 -50
Cooling	Capacity	kW	10.5	14	15.5
	Input	kW	3.38	4.08	4.6
Heating	Capacity	kW	11.5	15.5	17.5
	Input	kW	3.61	4.12	4.83
Max. input consumption		W	6200	6600	7650
Max. current		A	12.5	12.5	13.7
Compressor	Model		E405DHD-38D2G	E405DHD-38D2G	ANB42FBEMT
	Type		Scroll	Scroll	Scroll
	Brand		HITACHI	HITACHI	MITSUBISHI
	Capacity	Btu/h	42300	42300	47440
	Input	W	3880	3880	4140
	Rated current(RLA)	A	9.4	9.4	15.2
	Crankcase	W	33	33	38
	Refrigerant oil	ml	1200	1200	MEL56/1700
Outdoor fan motor	Model		YDK250-6E	YDK100-6A(×2)	YDK100-6A(×2)
	Type		AC motor	AC motor	AC motor
	Brand		Welling	Welling	Welling
	Insulation class		B	B	B
	Safe class		IPX4	IPX4	IPX4
	Input	W	307/194	185/120(×2)	185/120(×2)
	Output	W	250	100(×2)	100(×2)
	Rated current	A	1.4	0.8(×2)	0.8(×2)
	Capacitor	uF	10	3.5(×2)	3.5(×2)
	Speed	r/min	740/530	860/610(×2)	860/610(×2)
Outdoor fan	Material		ASG20	ASG20	ASG20
	Type		Axial fan	Axial fan	Axial fan
	Diameter	mm	556	460	460
	Height	mm	169	152	152
Outdoor coil	Number of rows		2	2	3
	Tube pitch(a)x row pitch(b)	mm	25.4/22	25.4*22	22*19.05
	Fin spacing	mm	1.7	1.8	1.6
	Fin type (code)		Hydrophilic aluminum		
	Tube outside dia.and type	mm	Φ9.5	Φ9.5	Φ7.94
	Coil length x height	mm	888*915*44	887 x 1220 x 44	893 x 1188
	Number of circuits		6	8	8
Outdoor air flow		m ³ /h	5400/3900	6500/4300	6500/4300
Outdoor sound level(sound pressure level)		dB(A)	58/55	57/54	57/54
Outdoor unit	Dimension(W*H*D)	mm	990x 966x 354	940x 1245x 360	940x 1245x 360
	Packing (W*H*D)	mm	1120x 1100x 435	1058x 1380x 438	1077x1380x438
	Net/Gross weight	kg	104/111	115/121	125/138.5
Refrigerant	Type		R410A	R410A	R410A
	Charged volume	g	2800	4400	4500
Throttle type			Electron expansion valve		
Design pressure		MPa	4.2 / 2.0	4.2 / 2.0	4.4 / 2.6
Refrigerant piping	Liquid side/ Gas side	mm	Φ9.53/Φ15.9	Φ9.53/Φ15.9	Φ9.53/Φ15.9
	Max. refrigerant pipe enpth	m	100	100	100
	Max. difference in level	m	20	20	20
Connection wiring	Power wiring	mm ²	5 core x 2.5	5 core x 2.5	5 core x 2.5
	Signal wiring	mm ²	3 core shielded wire x 0.5		
Ambient temp		°C	(Cooling -15~43) (Heating -15~21)		

2. Dimensions

MDV-V80W/N1 MDV-V105W/N1-B MDV-V105W/BDRN1

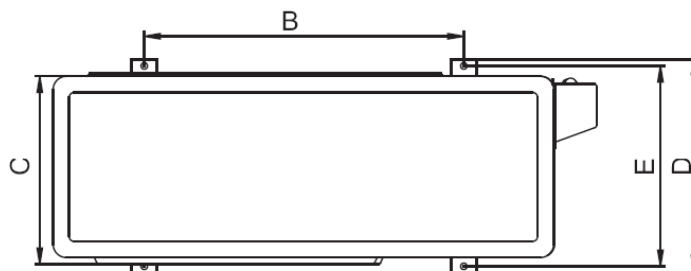
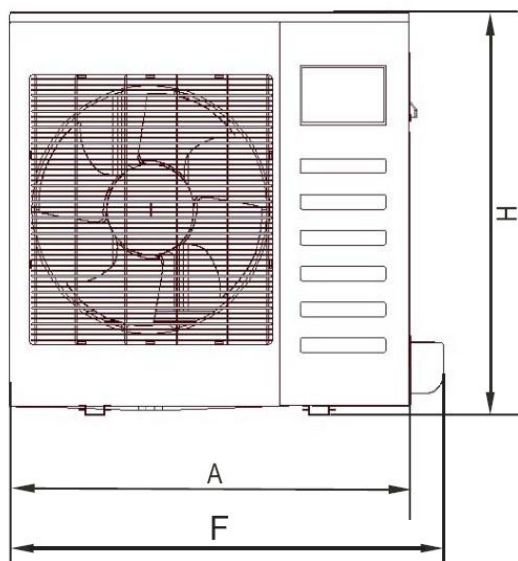

Unit:mm

MODEL	A	B	C	D	E	F	H
MDV-V80W/N1	895	590	313	355	333	975	862
MDV-V105W/N1-B	940	600	360	400	376	1020	1245
MDV-V105W/BDRN1	990	624	354	396	366	1075	966

MDV-V140W/BDRN1 MDV-V160W/BDRN1

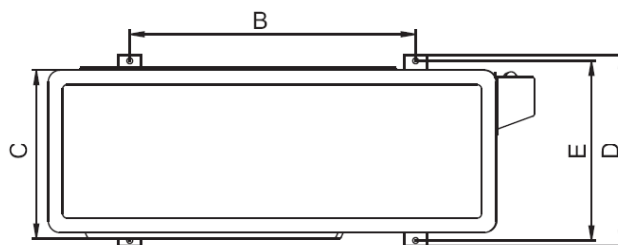
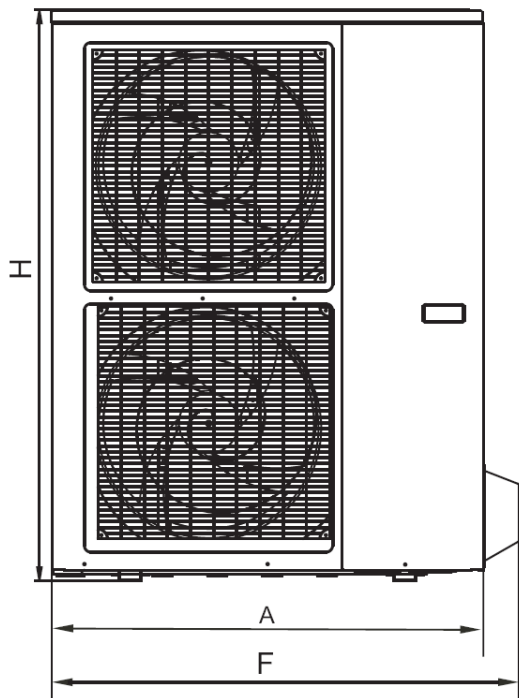

mm

MODEL	A	B	C	D	E	F	H
MDV-V105W/N1	940	600	360	400	376	1020	1245
MDV-V140W/N1	940	600	360	400	376	1020	1245
MDV-V140W/BDRN1	940	600	360	400	376	1020	1245
MDV-V160W/BDRN1-B	940	600	360	400	376	1020	1245

3. Service Space

- Single unit installation

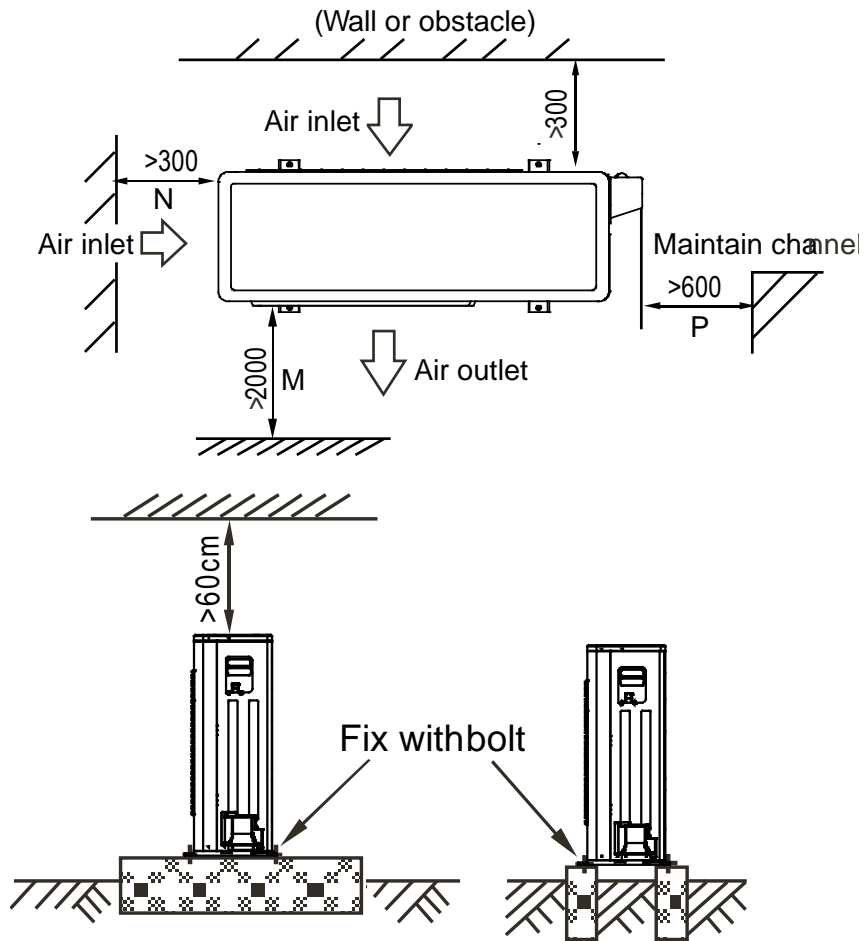

4. Piping Diagrams

MDV-V80W/N1 MDV-V105W/N1 MDV-V105W/N1-B MDV-V140W/N1

MDV-V105W/BDRN1 MDV-V140W/BDRN1 MDV-V160W/BDRN1-B

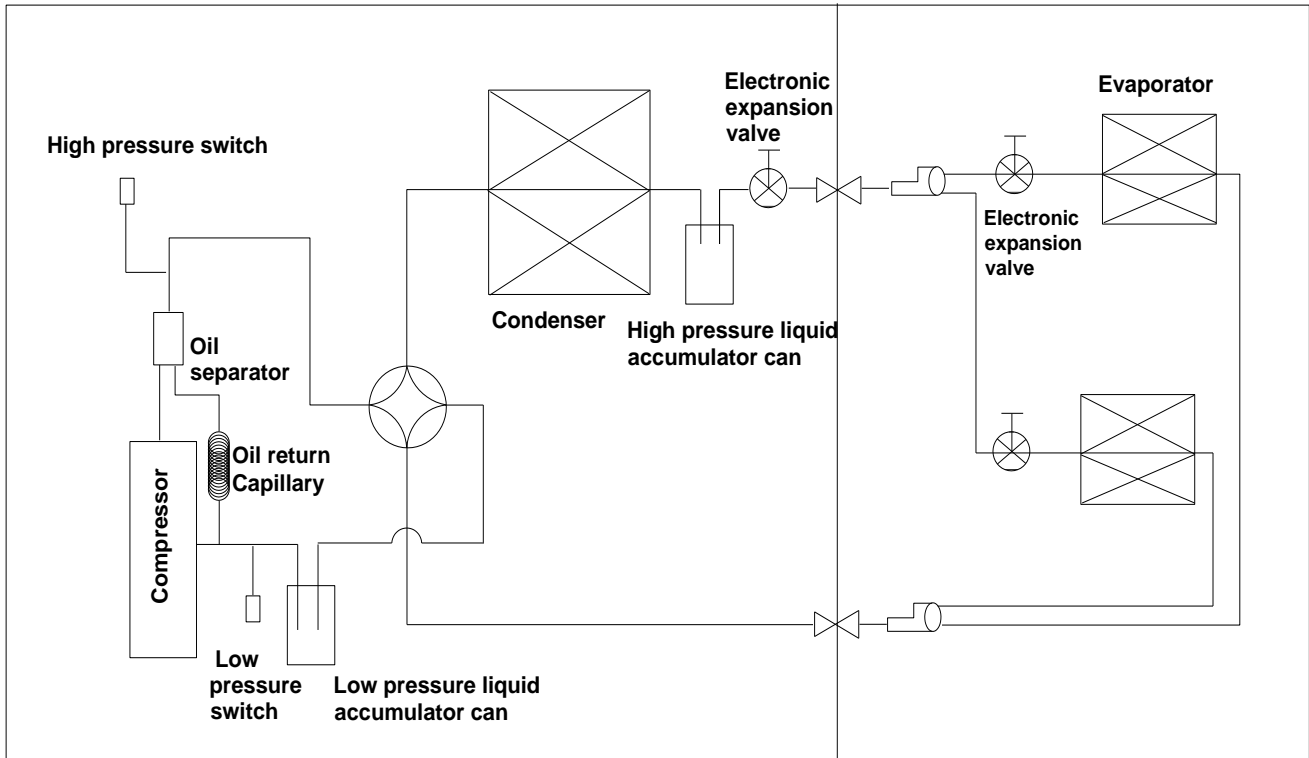

REMARK: for reference

5. Wiring Diagrams

MDV-V80W/N1

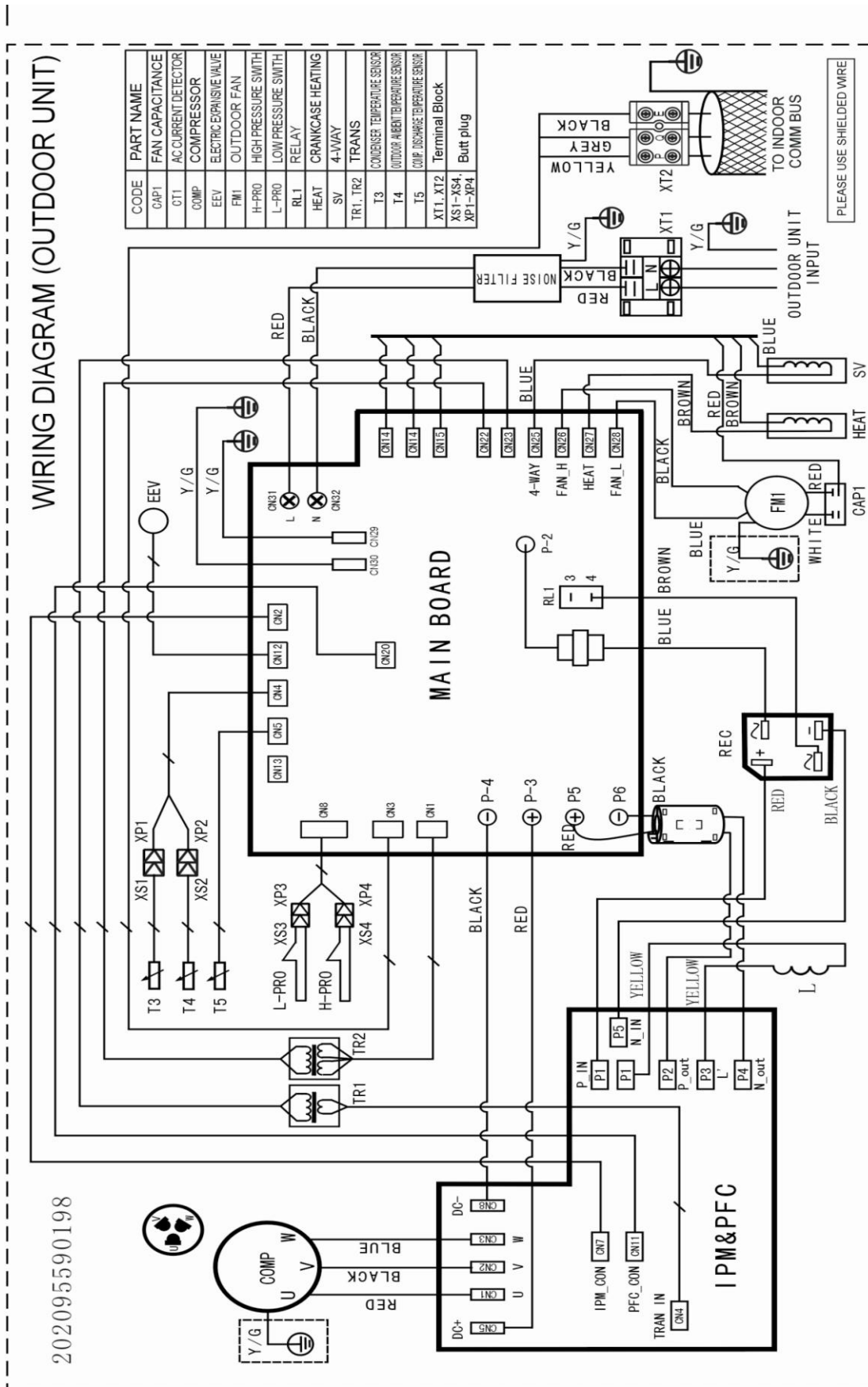

MDV-V105W/N1 MDV-V140W/N1

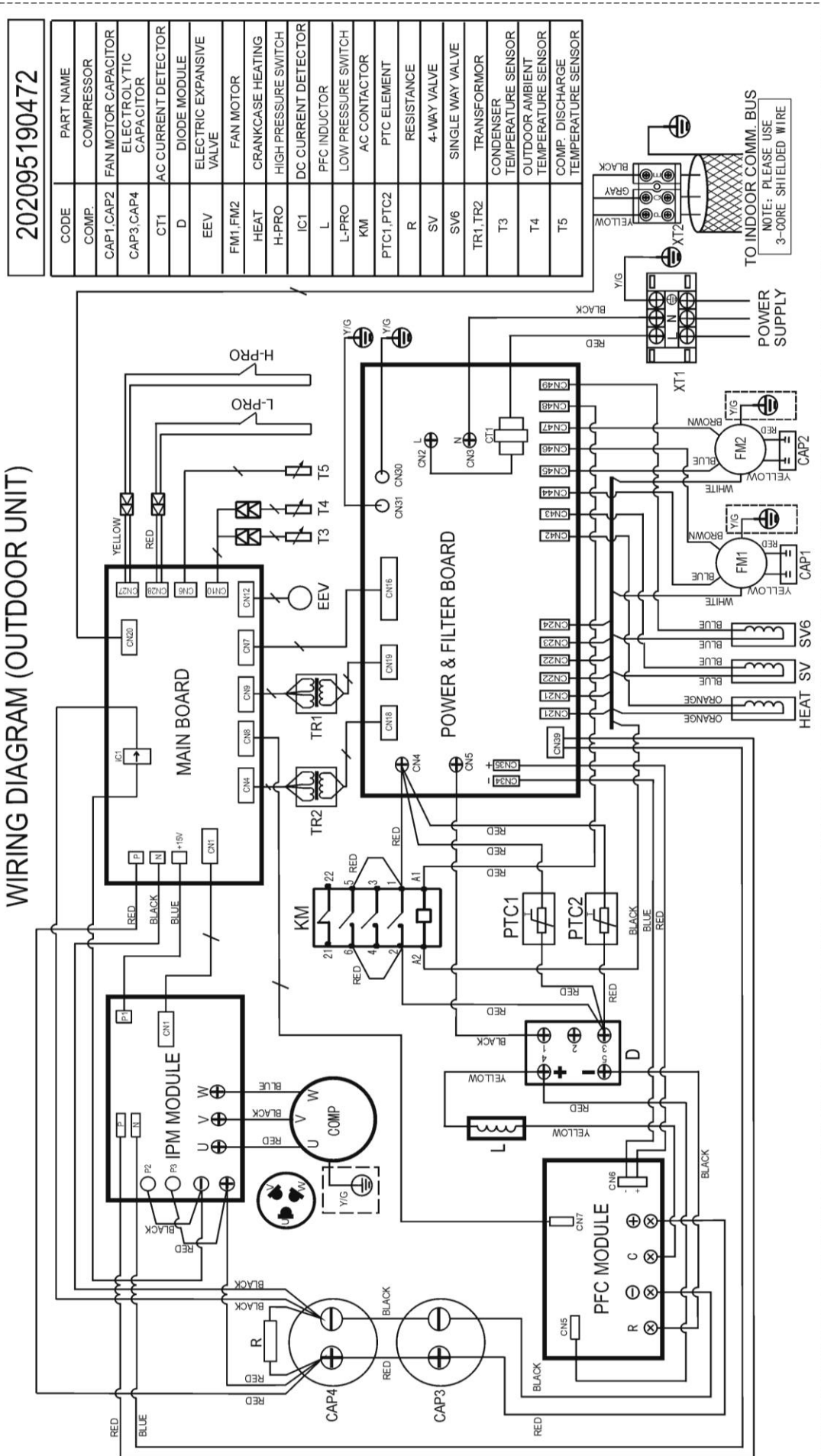

MDV-V105W/N1-B

WIRING DIAGRAM (OUTDOOR UNIT)

202095190263

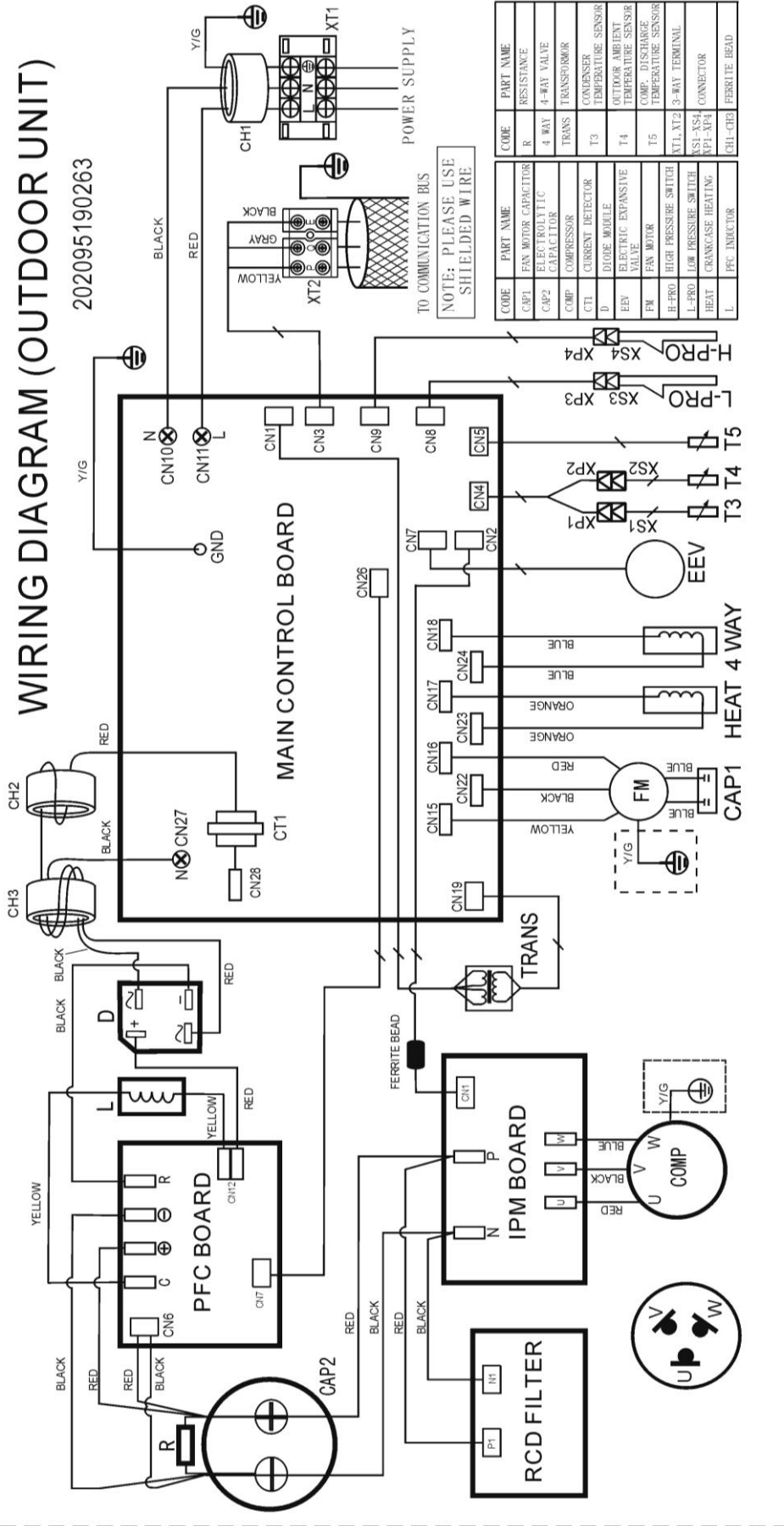

CODE	PART NAME	CODE	PART NAME
CAP1	FAN MOTOR CAPACITOR	R	RESISTANCE
CAP2	ELECTROLYTIC CAPACITOR	4-WAY	4-WAY VALVE
COMP	COMPRESSOR	TRANS	TRANSFORMER
CTL	CURRENT DETECTOR	T3	CONDENSER TEMPERATURE SENSOR
D	DIODE MODULE	T4	OUTDOOR AMBIENT TEMPERATURE SENSOR
EEV	ELECTRIC EXPANSIVE VALVE	T5	COMP. DISCHARGE TEMPERATURE SENSOR
FM	FAN MOTOR	ATL,AT2	3-WAY TERMINAL
H-PRO	HIGH PRESSURE SWITCH	ASI-XS4	CONNECTOR
L-PRO	LOW PRESSURE SWITCH	WPL-AP4	CONNECTOR
HEAT	CRANKCASE HEATING	CH1-CH3	FERRITE BEAD
L	IPFC INDUCTOR		

MDV-V105W/BDRN1

202095190222

WIRING DIAGRAM (OUTDOOR UNIT)

CODE	PART NAME
COMP.	COMPRESSOR
CAP1	FAN MOTOR CAPACITOR
CAP3,CAP4	450VDC CAPACITOR
CAP5	450VAC CAPACITOR
CT1	AC CURRENT DETECTOR
D1	3 PHASE RECTIFIER
D2	1 PHASE RECTIFIER
EEV	ELECTRIC EXPANSIVE VALVE
FAN	OUTDOOR FAN MOTOR
HEAT	CRANKCASE HEATING
SV	4-WAY VALVE
SV6	SINGLE WAY VALVE
H-PRO	HIGH PRESSURE SWITCH
IC1	DC CURRENT DETECTOR
L	REACTOR
L-PRO	LOW PRESSURE SWITCH
KM	AC CONTACTOR
PTC1,PTC2	PTC ELEMENT
R1,R2	RESISTANCE
TR1,TR2	TRANSFORMOR
T3	CONDENSER TEMPERATURE SENSOR
T4	OUTDOOR AMBIENT TEMPERATURE SENSOR
T5	TEMPERATURE SENSOR
CH1,CH2	COMP. DISCHARGE TEMPERATURE SENSOR
XT1	FERRITE BEAD
XT2	4-WAY TERMINAL
	3-WAY TERMINAL

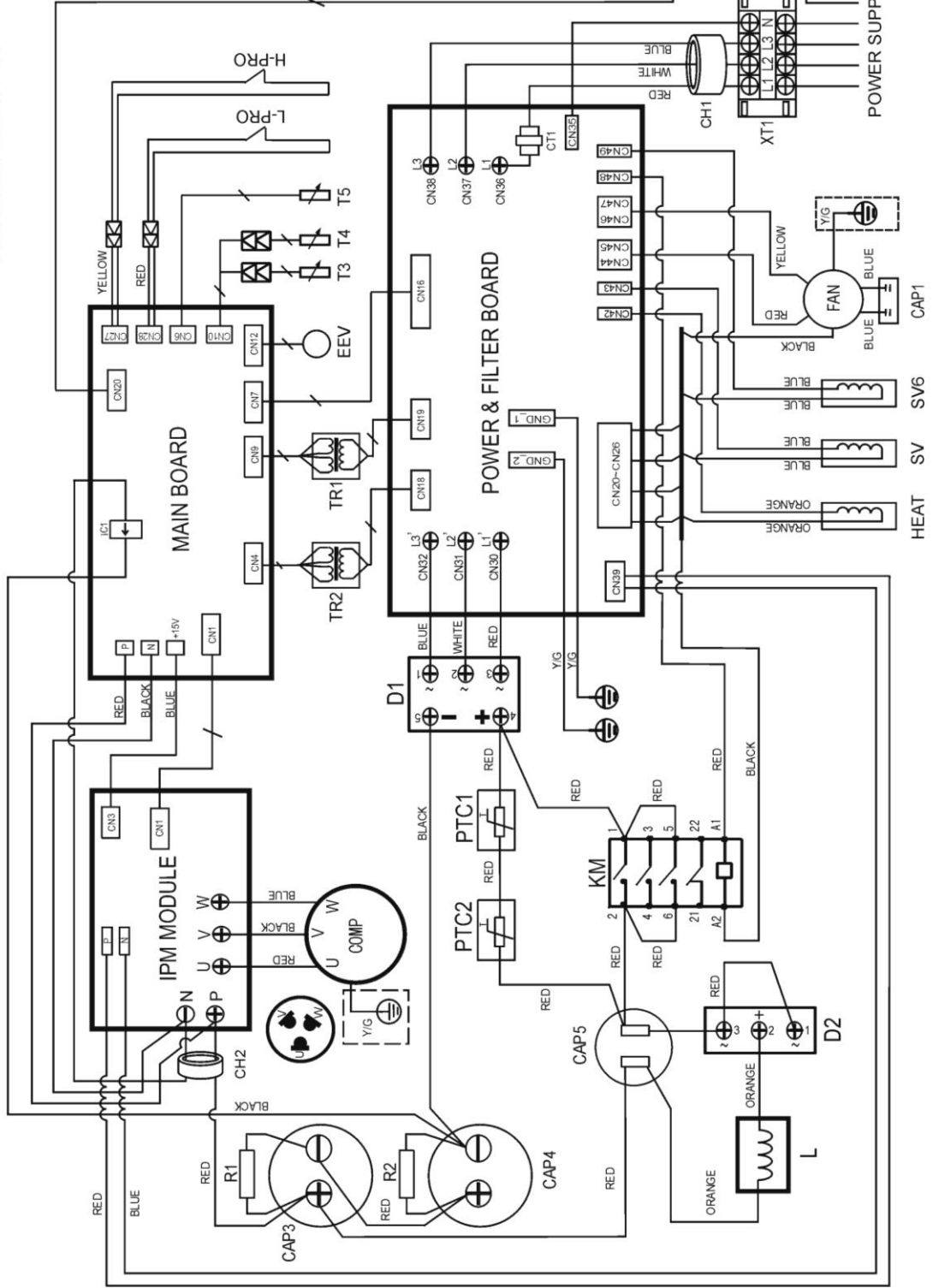

NOTE: PLEASE USE 3-CORE SHIELDED WIRE

MDV-V140W/BDRN1 MDV-V160W/BDRN1-B

WIRING DIAGRAM (OUTDOOR UNIT)

202095190017

CODE	PART NAME
COMP.	COMPRESSOR
CAP1,CAP2	FAN MOTOR CAPACITOR
CAP3,CAP4	450VDC CAPACITOR
CAP5	450VAC CAPACITOR
CT1	AC CURRENT DETECTOR
D1	3 PHASE RECTIFIER
D2	1 PHASE RECTIFIER
EEV	ELECTRIC EXPANSIVE VALVE
FAN1,FAN2	OUTDOOR FAN MOTOR
HEAT	CRANKCASE HEATING
SV	4-WAY VALVE
SV6	SINGLE WAY VALVE
H-PRO	HIGH PRESSURE SWITCH
IC1	DC CURRENT DETECTOR
L	REACTOR
L-PRO	LOW PRESSURE SWITCH
KM	AC CONTACTOR
PTC1,PTC2	PTC ELEMENT
R1,R2	RESISTANCE
TR1,TR2	TRANSFORMOR
T3	CONDENSER TEMPERATURE SENSOR
T4	OUTDOOR AMBIENT TEMPERATURE SENSOR
T5	COMP DISCHARGE TEMPERATURE SENSOR
CH1,CH2	FERRITE BEAD
XT1	4-WAY TERMINAL
XT2	3-WAY TERMINAL

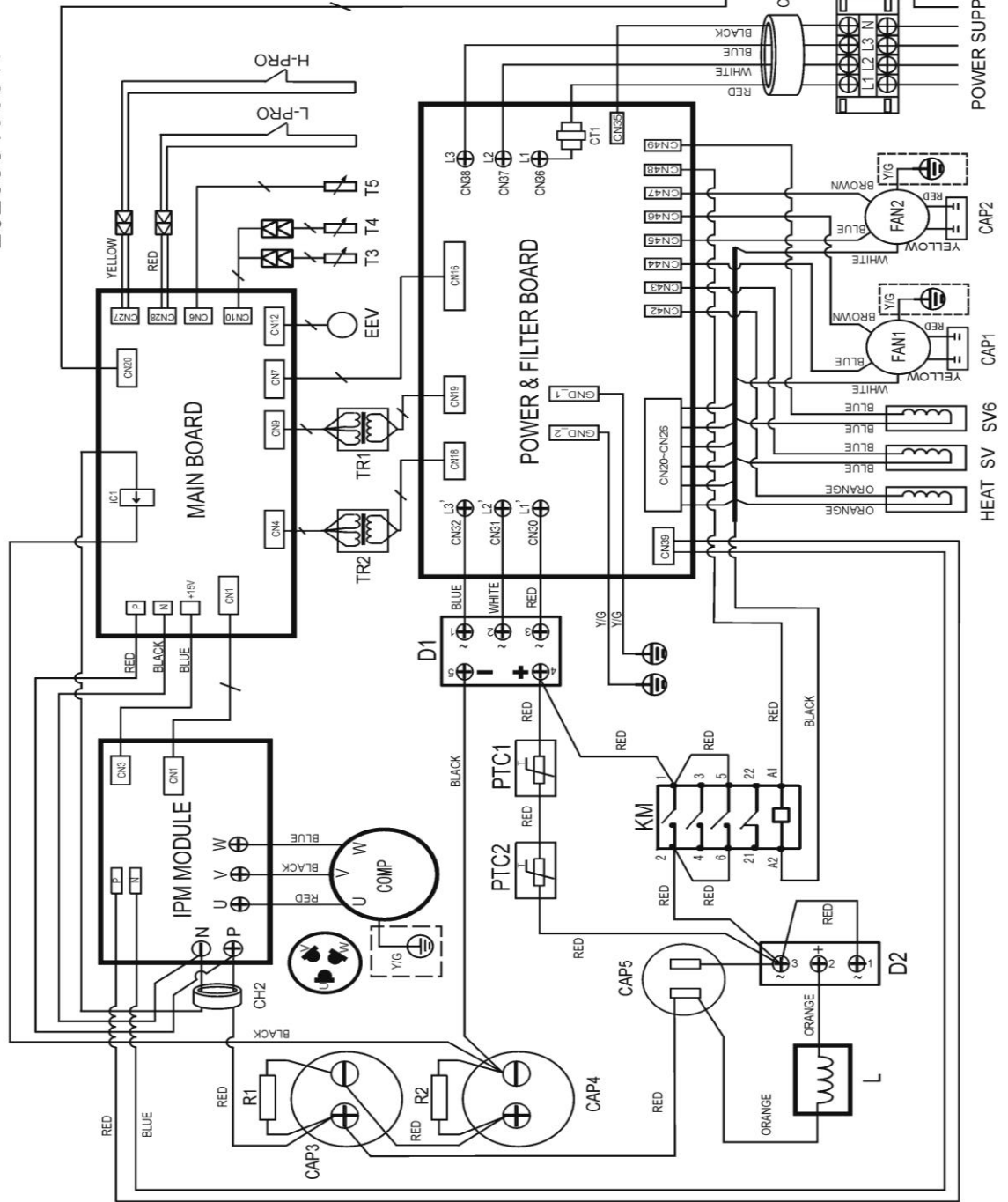

NOTE: PLEASE USE 3-CORE SHIELDED WIRE

6. Field Wiring

MDV-V80W/N1 MDV-V105W/N1 MDV-V105W/N1-B MDV-V140W/N1

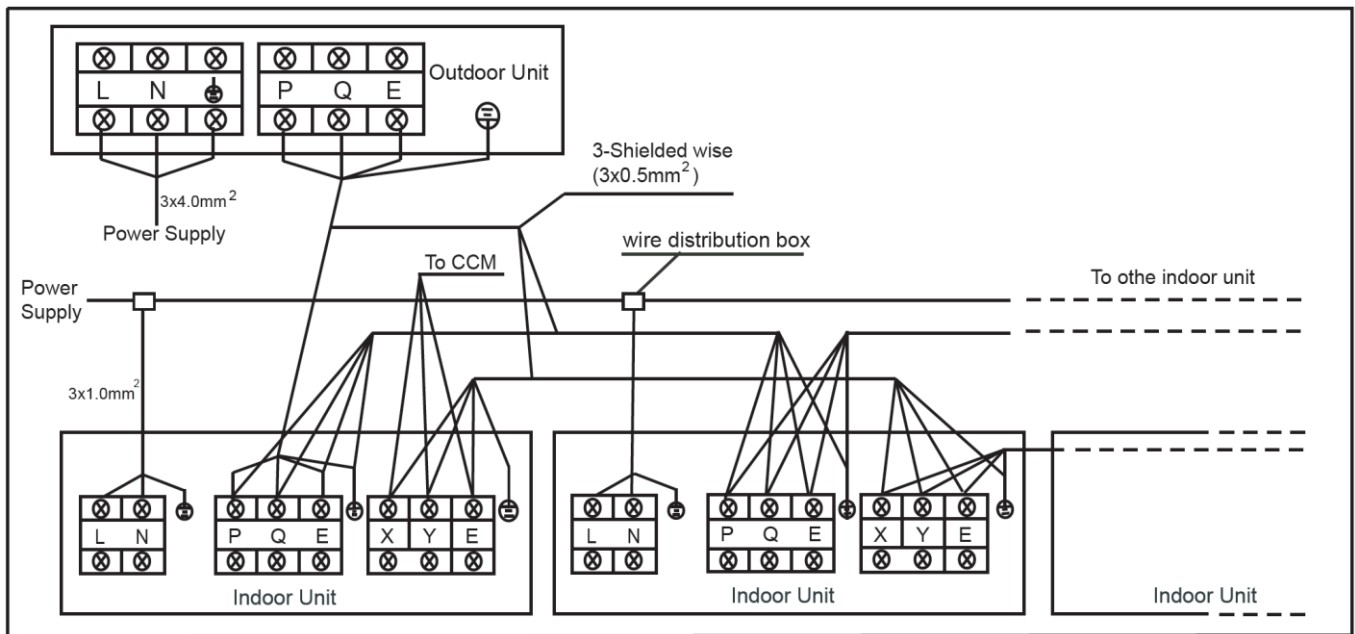
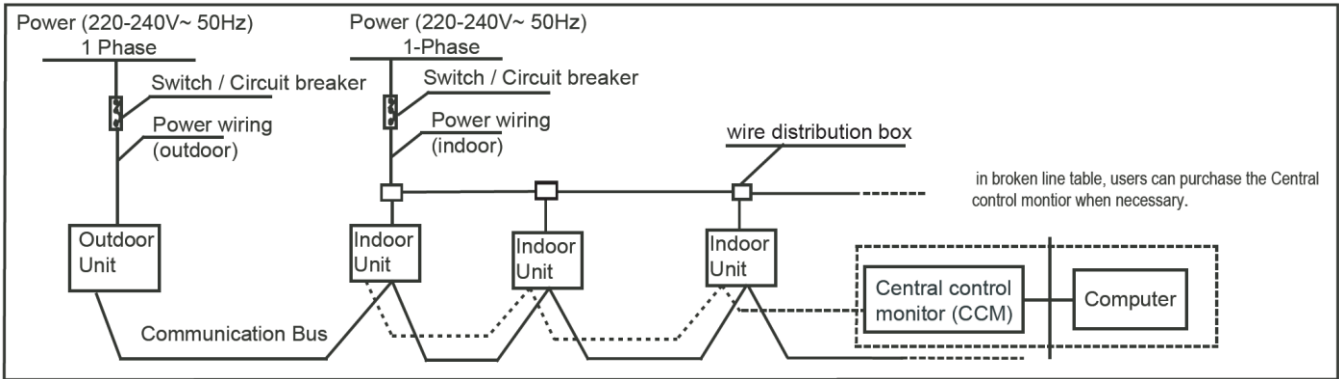

MDV-V105W/BDRN1 MDV-V140W/BDRN1 MDV-V160W/BDRN1-B

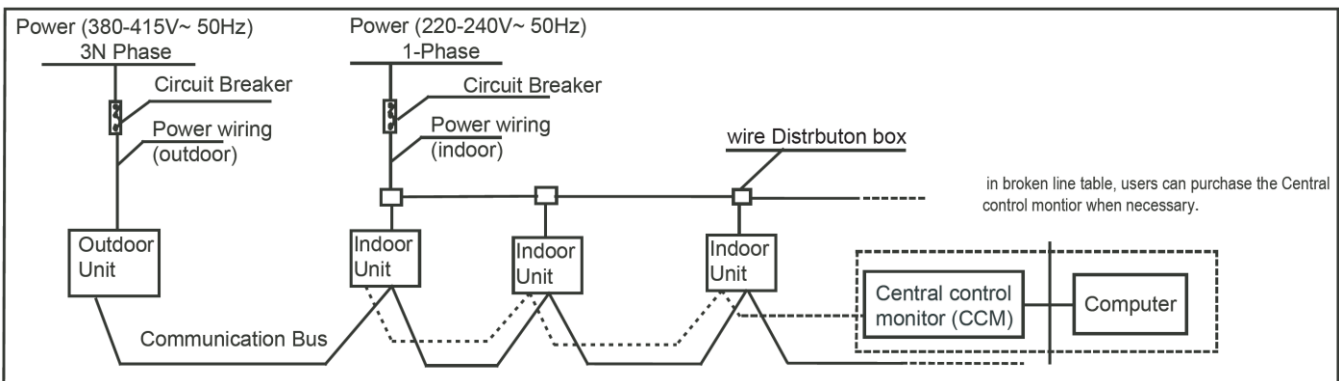

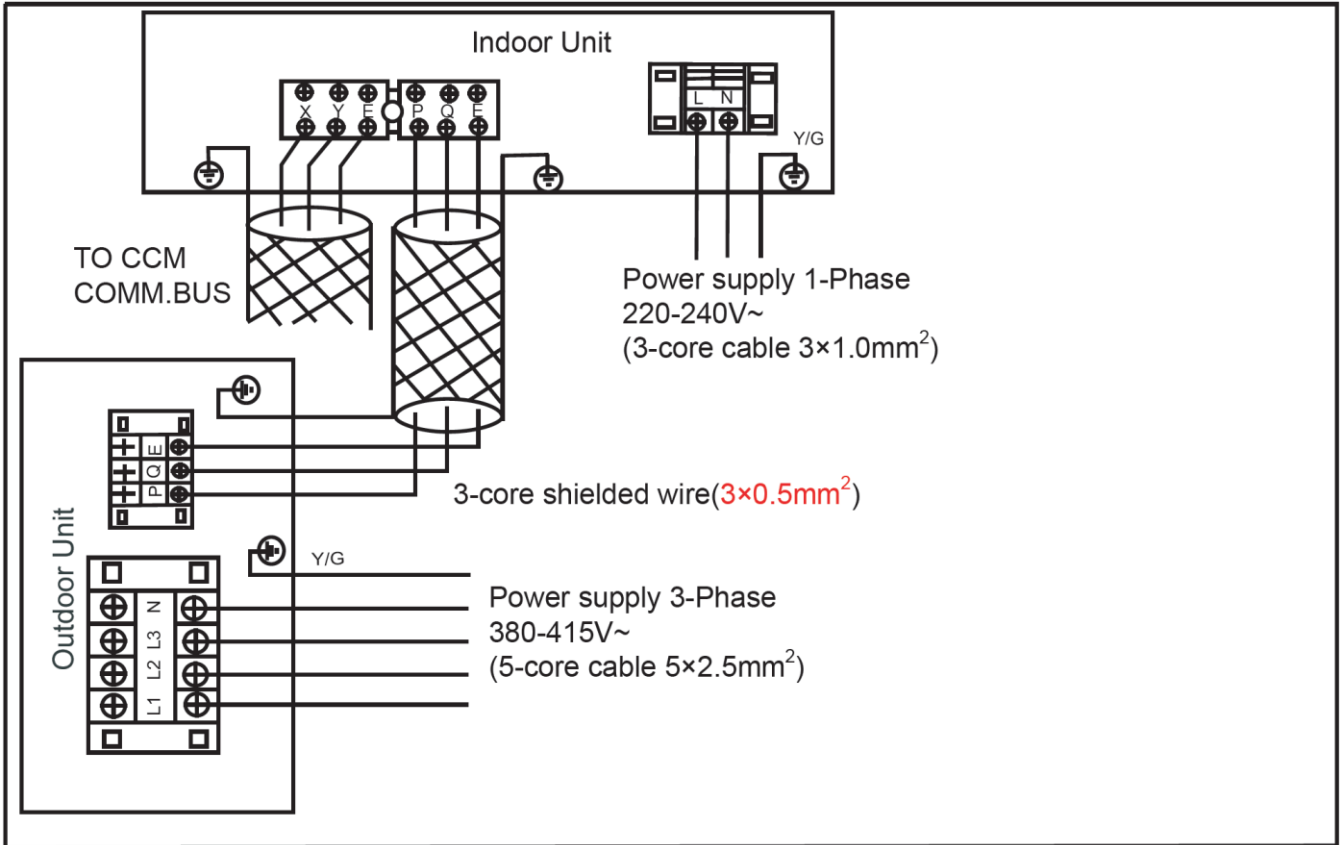

7. Capacity Tables

MDV-V80W/N1 Cooling

Combination (%) (Capacity index)	Outdoor temperature(°C DB)	Indoor temperature(°C WB)													
		14.00		16.00		18.00		19.00		20.00		22.00		24.00	
		TC	PI	TC	PI	TC	PI	TC	PI	TC	PI	TC	PI	TC	PI
		kW	kW	kW	kW	kW	kW	kW	kW	kW	kW	kW	kW	kW	kW
130%	10.00	7.03	1.18	8.37	1.44	9.71	1.71	10.09	1.75	10.20	1.72	10.46	1.65	10.71	1.57
	12.00	7.03	1.20	8.37	1.47	9.71	1.75	9.94	1.74	10.09	1.71	10.31	1.63	10.57	1.61
	14.00	7.03	1.23	8.37	1.50	9.69	1.77	9.83	1.75	9.94	1.70	10.20	1.68	10.46	1.70
	16.00	7.03	1.25	8.37	1.53	9.57	1.76	9.69	1.74	9.80	1.76	10.06	1.77	10.31	1.79
	18.00	7.03	1.27	8.37	1.56	9.43	1.83	9.54	1.84	9.69	1.85	9.94	1.87	10.20	1.88
	19.00	7.03	1.30	8.37	1.66	9.29	1.92	9.43	1.93	9.54	1.94	9.80	1.96	10.06	1.98
	21.00	7.03	1.33	8.37	1.72	9.23	1.96	9.37	1.97	9.49	1.98	9.74	2.00	10.00	2.02
	23.00	7.03	1.43	8.37	1.84	9.11	2.05	9.23	2.06	9.34	2.07	9.60	2.09	9.86	2.12
	25.00	7.03	1.53	8.37	1.97	8.97	2.14	9.09	2.15	9.23	2.17	9.49	2.19	9.74	2.21
	27.00	7.03	1.63	8.37	2.11	8.86	2.23	8.97	2.25	9.09	2.26	9.34	2.28	9.60	2.30
	29.00	7.03	1.74	8.37	2.26	8.71	2.32	8.83	2.34	8.97	2.35	9.23	2.37	9.49	2.40
	31.00	7.03	1.86	8.34	2.39	8.57	2.42	8.71	2.43	8.83	2.44	9.09	2.47	9.34	2.49
	33.00	7.03	1.98	8.20	2.48	8.46	2.50	8.57	2.52	8.71	2.53	8.97	2.56	9.20	2.59
	35.00	7.03	2.11	8.06	2.57	8.31	2.60	8.46	2.61	8.57	2.63	8.83	2.66	9.09	2.68
	37.00	7.03	2.24	7.94	2.66	8.20	2.69	8.31	2.71	8.46	2.72	8.69	2.75	8.94	2.78
39.00	7.03	2.39	7.80	2.69	8.06	2.78	8.20	2.80	8.31	2.82	8.57	2.85	8.83	2.88	
41.00	7.03	2.51	7.72	2.71	7.97	2.81	8.12	2.82	8.23	2.84	8.49	2.85	8.49	2.91	
43.00	7.03	2.58	7.66	2.73	7.93	2.81	8.07	2.84	8.14	2.85	8.33	2.86	8.39	2.91	
120%	10.00	6.49	1.08	7.71	1.31	8.97	1.56	9.60	1.69	10.06	1.76	10.29	1.69	10.51	1.63
	12.00	6.49	1.10	7.71	1.34	8.97	1.59	9.60	1.72	9.91	1.75	10.14	1.69	10.37	1.62
	14.00	6.49	1.12	7.71	1.37	8.97	1.62	9.60	1.76	9.77	1.74	10.03	1.68	10.26	1.69
	16.00	6.49	1.14	7.71	1.39	8.97	1.66	9.54	1.77	9.66	1.75	9.89	1.76	10.11	1.78
	18.00	6.49	1.16	7.71	1.42	8.97	1.71	9.40	1.83	9.51	1.84	9.74	1.85	10.00	1.87
	19.00	6.49	1.18	7.71	1.48	8.97	1.84	9.29	1.92	9.40	1.93	9.63	1.94	9.86	1.96
	21.00	6.49	1.19	7.71	1.53	8.97	1.91	9.20	1.96	9.31	1.97	9.57	1.99	9.80	2.01
	23.00	6.49	1.28	7.71	1.64	8.97	2.04	9.09	2.05	9.20	2.06	9.43	2.08	9.66	2.10
	25.00	6.49	1.36	7.71	1.75	8.83	2.13	8.94	2.14	9.06	2.15	9.31	2.17	9.54	2.19
	27.00	6.49	1.46	7.71	1.87	8.71	2.22	8.83	2.23	8.94	2.24	9.17	2.26	9.40	2.28
	29.00	6.49	1.55	7.71	2.00	8.57	2.31	8.69	2.32	8.80	2.33	9.03	2.36	9.29	2.38
	31.00	6.49	1.66	7.71	2.14	8.43	2.40	8.57	2.41	8.69	2.43	8.91	2.45	9.14	2.47
	33.00	6.49	1.76	7.71	2.28	8.31	2.49	8.43	2.50	8.54	2.52	8.77	2.54	9.00	2.57
	35.00	6.49	1.88	7.71	2.43	8.17	2.58	8.29	2.59	8.43	2.61	8.66	2.64	8.89	2.66
	37.00	6.49	2.00	7.71	2.59	8.06	2.67	8.17	2.69	8.29	2.70	8.51	2.73	8.74	2.76
39.00	6.49	2.13	7.69	2.73	7.91	2.76	8.03	2.78	8.14	2.79	8.40	2.83	8.63	2.85	
41.00	6.49	2.18	7.62	2.75	7.85	2.78	7.97	2.80	8.08	2.81	8.34	2.83	8.38	2.87	
43.00	6.49	2.22	7.58	2.77	7.79	2.80	7.90	2.81	8.02	2.82	8.19	2.84	8.25	2.93	
110%	10.00	5.94	0.98	7.09	1.19	8.23	1.41	8.80	1.53	9.37	1.65	10.09	1.75	10.31	1.69
	12.00	5.94	1.00	7.09	1.21	8.23	1.44	8.80	1.56	9.37	1.68	9.97	1.74	10.17	1.68
	14.00	5.94	1.01	7.09	1.24	8.23	1.47	8.80	1.59	9.37	1.71	9.83	1.73	10.06	1.67
	16.00	5.94	1.03	7.09	1.26	8.23	1.50	8.80	1.62	9.37	1.74	9.71	1.75	9.91	1.77
	18.00	5.94	1.05	7.09	1.28	8.23	1.53	8.80	1.66	9.37	1.83	9.57	1.84	9.80	1.86
	19.00	5.94	1.07	7.09	1.31	8.23	1.62	8.80	1.79	9.23	1.92	9.46	1.93	9.66	1.95
	21.00	5.94	1.08	7.09	1.35	8.23	1.68	8.80	1.85	9.17	1.96	9.37	1.97	9.60	1.99
	23.00	5.94	1.14	7.09	1.45	8.23	1.80	8.80	1.99	9.03	2.05	9.26	2.07	9.46	2.08
	25.00	5.94	1.21	7.09	1.55	8.23	1.92	8.80	2.13	8.91	2.14	9.11	2.16	9.34	2.17
	27.00	5.94	1.29	7.09	1.65	8.23	2.06	8.66	2.22	8.77	2.23	9.00	2.25	9.20	2.27
29.00	5.94	1.38	7.09	1.76	8.23	2.20	8.54	2.31	8.66	2.32	8.86	2.34	9.09	2.36	
31.00	5.94	1.47	7.09	1.88	8.23	2.35	8.40	2.40	8.51	2.41	8.74	2.43	8.94	2.45	

Capacity Tables

MHVAC-HTSM- 2011-07

	33.00	5.94	1.56	7.09	2.00	8.17	2.47	8.29	2.49	8.40	2.50	8.60	2.52	8.83	2.55
	35.00	5.94	1.66	7.09	2.14	8.03	2.56	8.14	2.58	8.26	2.59	8.46	2.62	8.69	2.64
	37.00	5.94	1.77	7.09	2.27	7.91	2.66	8.03	2.67	8.11	2.68	8.34	2.71	8.54	2.73
	39.00	5.94	1.88	7.09	2.42	7.77	2.75	7.89	2.76	8.00	2.77	8.20	2.80	8.43	2.83
	41.00	5.94	1.90	7.09	2.44	7.71	2.77	7.82	2.78	7.94	2.79	8.10	2.82	8.18	2.85
	43.00	5.94	1.92	7.09	2.47	7.65	2.79	7.76	2.80	7.88	2.81	8.02	2.83	8.05	2.91
100%	10.00	5.40	0.88	6.43	1.07	7.49	1.27	8.00	1.37	8.51	1.47	9.57	1.68	10.11	1.74
	12.00	5.40	0.90	6.43	1.09	7.49	1.29	8.00	1.39	8.51	1.50	9.57	1.71	9.97	1.73
	14.00	5.40	0.91	6.43	1.11	7.49	1.31	8.00	1.42	8.51	1.53	9.57	1.75	9.86	1.72
	16.00	5.40	0.93	6.43	1.13	7.49	1.34	8.00	1.45	8.51	1.56	9.51	1.77	9.71	1.75
	18.00	5.40	0.95	6.43	1.15	7.49	1.37	8.00	1.48	8.51	1.59	9.40	1.83	9.60	1.84
	19.00	5.40	0.97	6.43	1.18	7.49	1.41	8.00	1.55	8.51	1.70	9.26	1.91	9.46	1.93
	21.00	5.40	0.98	6.43	1.19	7.49	1.46	8.00	1.61	8.51	1.76	9.20	1.96	9.40	1.98
	23.00	5.40	1.00	6.43	1.27	7.49	1.56	8.00	1.72	8.51	1.89	9.09	2.05	9.26	2.07
	25.00	5.40	1.07	6.43	1.35	7.49	1.67	8.00	1.85	8.51	2.03	8.94	2.14	9.14	2.16
	27.00	5.40	1.14	6.43	1.44	7.49	1.79	8.00	1.97	8.51	2.17	8.80	2.23	9.00	2.25
	29.00	5.40	1.21	6.43	1.54	7.49	1.91	8.00	2.11	8.49	2.30	8.69	2.32	8.89	2.34
	31.00	5.40	1.29	6.43	1.64	7.49	2.04	8.00	2.25	8.37	2.39	8.54	2.41	8.74	2.43
	33.00	5.40	1.37	6.43	1.75	7.49	2.17	8.00	2.40	8.23	2.48	8.43	2.50	8.63	2.53
	35.00	5.40	1.46	6.43	1.86	7.49	2.32	8.00	2.56	8.09	2.57	8.29	2.59	8.49	2.62
37.00	5.40	1.55	6.43	1.98	7.49	2.47	7.86	2.65	7.97	2.66	8.17	2.69	8.34	2.71	
39.00	5.40	1.65	6.43	2.10	7.49	2.63	7.74	2.74	7.83	2.75	8.03	2.78	8.23	2.80	
41.00	5.40	1.72	6.43	2.18	7.49	2.72	7.62	2.76	7.77	2.80	7.89	2.84	8.11	2.86	
43.00	5.40	1.80	6.43	2.26	7.49	2.77	7.50	2.79	7.71	2.82	7.94	2.86	7.97	2.89	
90%	10.00	4.86	0.79	5.80	0.95	6.74	1.12	7.20	1.21	7.66	1.30	8.60	1.49	9.54	1.68
	12.00	4.86	0.80	5.80	0.97	6.74	1.15	7.20	1.23	7.66	1.33	8.60	1.52	9.54	1.71
	14.00	4.86	0.82	5.80	0.99	6.74	1.17	7.20	1.26	7.66	1.35	8.60	1.55	9.54	1.74
	16.00	4.86	0.83	5.80	1.00	6.74	1.19	7.20	1.28	7.66	1.38	8.60	1.58	9.51	1.77
	18.00	4.86	0.85	5.80	1.02	6.74	1.21	7.20	1.31	7.66	1.41	8.60	1.61	9.40	1.83
	19.00	4.86	0.86	5.80	1.05	6.74	1.24	7.20	1.34	7.66	1.46	8.60	1.73	9.26	1.91
	21.00	4.86	0.87	5.80	1.06	6.74	1.26	7.20	1.38	7.66	1.51	8.60	1.79	9.20	1.96
	23.00	4.86	0.89	5.80	1.10	6.74	1.35	7.20	1.48	7.66	1.62	8.60	1.92	9.06	2.05
	25.00	4.86	0.93	5.80	1.17	6.74	1.44	7.20	1.58	7.66	1.73	8.60	2.06	8.94	2.14
	27.00	4.86	0.99	5.80	1.25	6.74	1.54	7.20	1.69	7.66	1.85	8.60	2.20	8.80	2.23
	29.00	4.86	1.06	5.80	1.33	6.74	1.64	7.20	1.80	7.66	1.98	8.51	2.30	8.69	2.32
	31.00	4.86	1.12	5.80	1.42	6.74	1.75	7.20	1.93	7.66	2.11	8.37	2.39	8.54	2.41
	33.00	4.86	1.19	5.80	1.51	6.74	1.86	7.20	2.05	7.66	2.25	8.26	2.48	8.43	2.50
	35.00	4.86	1.27	5.80	1.60	6.74	1.98	7.20	2.19	7.66	2.40	8.11	2.57	8.29	2.59
37.00	4.86	1.35	5.80	1.70	6.74	2.11	7.20	2.33	7.66	2.56	7.97	2.66	8.17	2.68	
39.00	4.86	1.43	5.80	1.81	6.74	2.25	7.20	2.48	7.66	2.73	7.86	2.76	8.03	2.78	
41.00	4.86	1.48	5.80	1.90	6.74	2.33	7.20	2.55	7.66	2.74	7.80	2.83	7.97	2.84	
43.00	4.86	1.55	5.80	1.98	6.74	2.41	7.20	2.61	7.66	2.80	7.76	2.86	7.91	2.89	
80%	10.00	4.31	0.70	5.14	0.84	5.97	0.99	6.40	1.06	6.83	1.14	7.66	1.30	8.49	1.47
	12.00	4.31	0.71	5.14	0.85	5.97	1.00	6.40	1.08	6.83	1.16	7.66	1.32	8.49	1.49
	14.00	4.31	0.72	5.14	0.87	5.97	1.02	6.40	1.10	6.83	1.18	7.66	1.35	8.49	1.52
	16.00	4.31	0.73	5.14	0.88	5.97	1.04	6.40	1.12	6.83	1.20	7.66	1.38	8.49	1.55
	18.00	4.31	0.75	5.14	0.90	5.97	1.06	6.40	1.15	6.83	1.23	7.66	1.40	8.49	1.58
	19.00	4.31	0.76	5.14	0.92	5.97	1.08	6.40	1.17	6.83	1.25	7.66	1.46	8.49	1.69
	21.00	4.31	0.77	5.14	0.92	5.97	1.09	6.40	1.18	6.83	1.28	7.66	1.51	8.49	1.75
	23.00	4.31	0.78	5.14	0.95	5.97	1.15	6.40	1.26	6.83	1.37	7.66	1.61	8.49	1.88
	25.00	4.31	0.81	5.14	1.00	5.97	1.22	6.40	1.34	6.83	1.46	7.66	1.73	8.49	2.01
	27.00	4.31	0.86	5.14	1.07	5.97	1.30	6.40	1.43	6.83	1.56	7.66	1.85	8.49	2.15
	29.00	4.31	0.91	5.14	1.14	5.97	1.39	6.40	1.52	6.83	1.67	7.66	1.97	8.49	2.30
	31.00	4.31	0.97	5.14	1.21	5.97	1.48	6.40	1.63	6.83	1.78	7.66	2.10	8.34	2.39
	33.00	4.31	1.03	5.14	1.29	5.97	1.58	6.40	1.73	6.83	1.89	7.66	2.24	8.23	2.48
	35.00	4.31	1.09	5.14	1.37	5.97	1.68	6.40	1.84	6.83	2.02	7.66	2.39	8.09	2.57
39.00	4.31	1.23	5.14	1.55	5.97	1.90	6.40	2.09	6.83	2.29	7.66	2.72	7.83	2.75	
41.00	4.31	1.26	5.14	1.56	5.97	1.93	6.40	2.14	6.83	2.33	7.66	2.78	7.78	2.80	

	43.00	4.31	1.29	5.14	1.58	5.97	1.95	6.40	2.18	6.83	2.36	7.66	2.82	7.73	2.83
70%	10.00	3.77	0.62	4.51	0.73	5.23	0.85	5.60	0.92	5.97	0.98	6.69	1.12	7.43	1.26
	12.00	3.77	0.62	4.51	0.74	5.23	0.87	5.60	0.94	5.97	1.00	6.69	1.14	7.43	1.28
	14.00	3.77	0.63	4.51	0.76	5.23	0.88	5.60	0.95	5.97	1.02	6.69	1.16	7.43	1.30
	16.00	3.77	0.65	4.51	0.77	5.23	0.90	5.60	0.97	5.97	1.04	6.69	1.18	7.43	1.33
	18.00	3.77	0.66	4.51	0.78	5.23	0.92	5.60	0.99	5.97	1.06	6.69	1.20	7.43	1.36
	19.00	3.77	0.67	4.51	0.80	5.23	0.94	5.60	1.00	5.97	1.08	6.69	1.23	7.43	1.39
	21.00	3.77	0.67	4.51	0.80	5.23	0.94	5.60	1.01	5.97	1.09	6.69	1.25	7.43	1.44
	23.00	3.77	0.68	4.51	0.82	5.23	0.96	5.60	1.05	5.97	1.14	6.69	1.34	7.43	1.55
	25.00	3.77	0.70	4.51	0.85	5.23	1.02	5.60	1.12	5.97	1.22	6.69	1.43	7.43	1.65
	27.00	3.77	0.74	4.51	0.91	5.23	1.09	5.60	1.19	5.97	1.30	6.69	1.53	7.43	1.77
	29.00	3.77	0.78	4.51	0.96	5.23	1.16	5.60	1.27	5.97	1.38	6.69	1.63	7.43	1.89
	31.00	3.77	0.83	4.51	1.02	5.23	1.24	5.60	1.35	5.97	1.47	6.69	1.73	7.43	2.01
	33.00	3.77	0.88	4.51	1.09	5.23	1.32	5.60	1.44	5.97	1.57	6.69	1.85	7.43	2.15
	35.00	3.77	0.93	4.51	1.15	5.23	1.40	5.60	1.53	5.97	1.67	6.69	1.97	7.43	2.29
	37.00	3.77	0.98	4.51	1.22	5.23	1.49	5.60	1.63	5.97	1.78	6.69	2.09	7.43	2.44
	39.00	3.77	1.04	4.51	1.29	5.23	1.58	5.60	1.73	5.97	1.89	6.69	2.23	7.43	2.59
41.00	3.77	1.09	4.51	1.34	5.23	1.62	5.60	1.79	5.97	1.94	6.69	2.32	7.43	2.71	
43.00	3.77	1.18	4.51	1.43	5.23	1.69	5.60	1.88	5.97	2.00	6.69	2.40	7.43	2.79	
60%	10.00	3.23	0.53	3.86	0.63	4.49	0.73	4.80	0.78	5.11	0.83	5.74	0.94	6.37	1.06
	12.00	3.23	0.55	3.86	0.64	4.49	0.74	4.80	0.79	5.11	0.85	5.74	0.96	6.37	1.07
	14.00	3.23	0.55	3.86	0.65	4.49	0.75	4.80	0.81	5.11	0.86	5.74	0.98	6.37	1.09
	16.00	3.23	0.56	3.86	0.66	4.49	0.77	4.80	0.82	5.11	0.88	5.74	0.99	6.37	1.11
	18.00	3.23	0.57	3.86	0.67	4.49	0.78	4.80	0.83	5.11	0.89	5.74	1.01	6.37	1.13
	19.00	3.23	0.58	3.86	0.68	4.49	0.79	4.80	0.85	5.11	0.91	5.74	1.03	6.37	1.16
	21.00	3.23	0.58	3.86	0.69	4.49	0.80	4.80	0.86	5.11	0.92	5.74	1.04	6.37	1.17
	23.00	3.23	0.59	3.86	0.70	4.49	0.81	4.80	0.88	5.11	0.93	5.74	1.08	6.37	1.25
	25.00	3.23	0.60	3.86	0.71	4.49	0.85	4.80	0.92	5.11	0.99	5.74	1.16	6.37	1.33
	27.00	3.23	0.62	3.86	0.76	4.49	0.90	4.80	0.98	5.11	1.06	5.74	1.23	6.37	1.42
	29.00	3.23	0.66	3.86	0.80	4.49	0.96	4.80	1.04	5.11	1.13	5.74	1.31	6.37	1.51
	31.00	3.23	0.70	3.86	0.85	4.49	1.02	4.80	1.11	5.11	1.20	5.74	1.40	6.37	1.61
	33.00	3.23	0.74	3.86	0.90	4.49	1.08	4.80	1.18	5.11	1.28	5.74	1.49	6.37	1.72
	35.00	3.23	0.78	3.86	0.96	4.49	1.15	4.80	1.25	5.11	1.36	5.74	1.58	6.37	1.83
	37.00	3.23	0.83	3.86	1.01	4.49	1.21	4.80	1.32	5.11	1.44	5.74	1.68	6.37	1.95
	39.00	3.23	0.87	3.86	1.07	4.49	1.29	4.80	1.40	5.11	1.53	5.74	1.79	6.37	2.07
41.00	3.23	0.90	3.86	1.12	4.49	1.33	4.80	1.46	5.11	1.58	5.74	1.87	6.37	2.16	
43.00	3.23	0.93	3.86	1.16	4.49	1.38	4.80	1.50	5.11	1.64	5.74	1.95	6.37	2.26	
50%	10.00	2.70	0.46	3.23	0.53	3.74	0.61	4.00	0.65	4.26	0.69	4.77	0.78	5.31	0.87
	12.00	2.70	0.47	3.23	0.54	3.74	0.62	4.00	0.66	4.26	0.70	4.77	0.79	5.31	0.88
	14.00	2.70	0.47	3.23	0.55	3.74	0.63	4.00	0.67	4.26	0.71	4.77	0.80	5.31	0.90
	16.00	2.70	0.48	3.23	0.56	3.74	0.64	4.00	0.68	4.26	0.72	4.77	0.82	5.31	0.91
	18.00	2.70	0.49	3.23	0.57	3.74	0.65	4.00	0.69	4.26	0.74	4.77	0.83	5.31	0.93
	19.00	2.70	0.49	3.23	0.57	3.74	0.66	4.00	0.70	4.26	0.75	4.77	0.85	5.31	0.95
	21.00	2.70	0.50	3.23	0.58	3.74	0.67	4.00	0.71	4.26	0.76	4.77	0.86	5.31	0.96
	23.00	2.70	0.50	3.23	0.59	3.74	0.68	4.00	0.72	4.26	0.77	4.77	0.87	5.31	0.98
	25.00	2.70	0.51	3.23	0.60	3.74	0.69	4.00	0.74	4.26	0.80	4.77	0.91	5.31	1.04
	27.00	2.70	0.52	3.23	0.62	3.74	0.73	4.00	0.79	4.26	0.85	4.77	0.97	5.31	1.11
	29.00	2.70	0.55	3.23	0.66	3.74	0.77	4.00	0.83	4.26	0.90	4.77	1.03	5.31	1.18
	31.00	2.70	0.58	3.23	0.69	3.74	0.82	4.00	0.89	4.26	0.96	4.77	1.10	5.31	1.26
	33.00	2.70	0.61	3.23	0.73	3.74	0.87	4.00	0.94	4.26	1.01	4.77	1.17	5.31	1.34
	35.00	2.70	0.65	3.23	0.78	3.74	0.92	4.00	0.99	4.26	1.07	4.77	1.24	5.31	1.42
	37.00	2.70	0.68	3.23	0.82	3.74	0.97	4.00	1.05	4.26	1.14	4.77	1.32	5.31	1.51
	39.00	2.70	0.72	3.23	0.87	3.74	1.03	4.00	1.11	4.26	1.21	4.77	1.40	5.31	1.60
41.00	2.70	0.75	3.23	0.90	3.74	1.07	4.00	1.17	4.26	1.26	4.77	1.47	5.31	1.68	
43.00	2.70	0.80	3.23	0.97	3.74	1.10	4.00	1.22	4.26	1.29	4.77	1.55	5.31	1.75	

Heating

Combination (Capacity index)	Outdoor air temp.		Indoor temperature(°C DB)											
			16		18		20		21		22		24	
			TC	PI	TC	PI	TC	PI	TC	PI	TC	PI	TC	PI
°C DB	°C WB	kW	kW	kW	kW	kW	kW	kW	kW	kW	kW	kW	kW	
130%	-13.7	-15	6.40	2.14	6.37	2.27	6.34	2.39	6.34	2.45	6.31	2.51	6.31	2.64
	-11.8	-13	6.66	2.24	6.66	2.36	6.63	2.47	6.60	2.53	6.60	2.59	6.57	2.71
	-9.8	-11	6.97	2.34	6.94	2.45	6.91	2.56	6.91	2.62	6.91	2.67	6.89	2.79
	-9.5	-10	7.14	2.39	7.11	2.50	7.09	2.60	7.09	2.66	7.06	2.71	7.06	2.82
	-8.5	-9.1	7.29	2.43	7.26	2.53	7.26	2.64	7.23	2.70	7.23	2.75	7.20	2.86
	-7	-7.6	7.54	2.50	7.54	2.60	7.51	2.71	7.51	2.76	7.49	2.81	7.46	2.91
	-5	-5.6	7.94	2.59	7.91	2.69	7.89	2.79	7.89	2.84	7.86	2.89	7.86	2.98
	-3	-3.7	8.31	2.68	8.29	2.77	8.29	2.86	8.26	2.91	8.26	2.96	8.23	3.05
	0	-0.7	8.97	2.81	8.97	2.90	8.94	2.98	8.94	3.01	8.91	3.07	8.91	3.15
	3	2.2	9.68	2.92	9.66	3.01	9.63	3.09	9.63	3.13	9.63	3.17	9.60	3.25
	5	4.1	10.17	3.00	10.14	3.08	10.14	3.15	10.11	3.19	10.11	3.23	10.09	3.30
	7	6	10.69	3.07	10.66	3.14	10.66	3.21	10.63	3.25	10.63	3.28	10.20	3.15
	9	7.9	11.23	3.13	11.20	3.20	11.20	3.27	11.17	3.30	10.94	3.23	10.20	2.96
	11	9.8	11.80	3.20	11.77	3.26	11.71	3.30	11.31	3.17	10.94	3.04	10.20	2.79
	13	11.8	12.43	3.26	12.40	3.32	11.71	3.09	11.31	2.97	10.94	2.85	10.20	2.62
15	13.7	13.03	3.31	12.46	3.14	11.71	2.91	11.31	2.80	10.94	2.69	10.20	2.47	
120%	-13.7	-15	6.37	2.31	6.34	2.42	6.31	2.53	6.31	2.59	6.31	2.65	6.29	2.76
	-11.8	-13	6.63	2.40	6.63	2.51	6.60	2.62	6.60	2.67	6.57	2.72	6.57	2.83
	-9.8	-11	6.94	2.49	6.91	2.59	6.91	2.70	6.89	2.75	6.89	2.80	6.86	2.90
	-9.5	-10	7.12	2.53	7.09	2.64	7.06	2.73	7.06	2.79	7.06	2.84	7.03	2.94
	-8.5	-9.1	7.26	2.57	7.23	2.67	7.23	2.77	7.20	2.82	7.20	2.87	7.17	2.97
	-7	-7.6	7.51	2.64	7.51	2.73	7.49	2.83	7.49	2.88	7.46	2.92	7.46	3.02
	-5	-5.6	7.91	2.72	7.89	2.82	7.86	2.91	7.86	2.95	7.86	3.00	7.83	3.09
	-3	-3.7	8.29	2.81	8.29	2.89	8.26	2.98	8.26	3.02	8.23	3.07	8.23	3.15
	0	-0.7	8.94	2.92	8.94	3.01	8.91	3.08	8.91	3.13	8.89	3.16	8.89	3.25
	3	2.2	9.66	3.03	9.63	3.11	9.63	3.18	9.60	3.22	9.60	3.26	9.40	3.24
	5	4.1	10.14	3.10	10.11	3.17	10.11	3.24	10.09	3.28	10.09	3.31	9.40	3.04
	7	6	10.66	3.16	10.66	3.23	10.63	3.30	10.46	3.25	10.11	3.12	9.40	2.86
	9	7.9	11.20	3.23	11.17	3.29	10.80	3.18	10.46	3.06	10.11	2.93	9.40	2.69
	11	9.8	11.77	3.28	11.49	3.23	10.80	2.99	10.46	2.88	10.11	2.76	9.40	2.54
	13	11.8	12.20	3.25	11.49	3.03	10.80	2.81	10.46	2.70	10.11	2.59	9.40	2.39
15	13.7	12.20	3.06	11.49	2.85	10.80	2.65	10.46	2.54	10.11	2.45	9.40	2.25	
110%	-13.7	-15	6.34	2.47	6.32	2.58	6.29	2.68	6.29	2.73	6.29	2.79	6.26	2.89
	-11.8	-13	6.60	2.56	6.60	2.66	6.57	2.76	6.57	2.81	6.54	2.85	6.54	2.96
	-9.8	-11	6.91	2.64	6.89	2.73	6.89	2.83	6.86	2.88	6.86	2.92	6.86	3.02
	-9.5	-10	7.09	2.68	7.06	2.77	7.03	2.87	7.03	2.91	7.03	2.96	7.00	3.05
	-8.5	-9.1	7.23	2.72	7.20	2.81	7.20	2.90	7.17	2.95	7.17	2.99	7.17	2.73
	-7	-7.6	7.49	2.78	7.49	2.86	7.46	2.95	7.46	3.00	7.46	3.04	7.43	3.13
	-5	-5.6	7.89	2.86	7.86	2.94	7.83	3.02	7.83	3.07	7.83	3.11	7.80	3.19
	-3	-3.7	8.26	2.93	8.26	3.01	8.23	3.09	8.23	3.13	8.20	3.17	8.20	3.25
	0	-0.7	8.91	3.04	8.91	3.11	8.89	3.19	8.89	3.22	8.89	3.26	8.63	3.20
	3	2.2	9.63	3.14	9.60	3.21	9.60	3.28	9.57	3.31	9.26	3.17	8.63	2.91
	5	4.1	10.11	3.20	10.11	3.27	9.91	3.24	9.57	3.11	9.26	2.98	8.63	2.74
	7	6	10.63	3.26	10.54	3.28	9.91	3.04	9.57	2.92	9.26	2.81	8.63	2.58
	9	7.9	11.17	3.32	10.54	3.09	9.91	2.86	9.57	2.75	9.26	2.64	8.63	2.43
	11	9.8	11.17	3.12	10.54	2.90	9.91	2.69	9.57	2.59	9.26	2.49	8.63	2.29
	13	11.8	11.17	2.92	10.54	2.72	9.91	2.53	9.57	2.44	9.26	2.34	8.63	2.16
15	13.7	11.17	2.60	10.54	2.57	9.91	2.39	9.57	2.30	9.26	2.21	8.63	2.04	
100%	-13.7	-15	6.31	2.64	6.29	2.73	6.26	2.83	6.26	2.88	6.26	2.92	6.23	3.02
	-11.8	-13	6.57	2.72	6.57	2.81	6.54	2.90	6.54	2.94	6.54	2.99	6.51	3.08
	-9.8	-11	6.89	2.79	6.86	2.88	6.86	2.96	6.86	3.01	6.83	3.05	6.83	3.14

	-9.5	-10	7.06	2.83	7.03	2.91	7.03	3.00	7.00	3.04	7.00	3.08	6.97	3.17
	-8.5	-9.1	7.20	2.86	7.17	2.95	7.17	3.03	7.17	3.07	7.14	3.11	7.14	3.19
	-7	-7.6	7.46	2.92	7.46	3.00	7.43	3.08	7.43	3.12	7.43	3.16	7.40	3.24
	-5	-5.6	7.86	2.99	7.83	3.07	7.83	3.14	7.80	3.18	7.80	3.22	7.77	3.29
	-3	-3.7	8.23	3.06	8.23	2.78	8.20	3.20	8.20	3.24	8.20	3.27	7.86	3.14
	0	-0.7	8.89	3.16	8.89	3.22	8.86	3.29	8.71	3.24	8.43	3.10	7.86	2.85
	3	2.2	9.60	3.25	9.57	3.31	9.00	3.06	8.71	2.94	8.43	2.83	7.86	2.59
	5	4.1	10.09	3.31	9.57	3.11	9.00	2.88	8.71	2.77	8.43	2.66	7.86	2.45
	7	6	10.14	3.14	9.57	2.92	9.00	2.71	8.71	2.61	8.43	2.51	7.86	2.31
	9	7.9	10.14	2.95	9.57	2.75	9.00	2.55	8.71	2.42	8.43	2.36	7.86	2.18
	11	9.8	10.14	2.78	9.57	2.59	9.00	2.41	8.71	2.32	8.43	2.23	7.86	2.06
	13	11.8	10.14	2.61	9.57	2.44	9.00	2.27	8.71	2.18	8.43	2.10	7.86	1.94
	15	13.7	10.14	2.46	9.57	2.30	9.00	2.14	8.71	2.06	8.43	1.99	7.86	1.84
90%	-13.7	-15	6.27	2.81	6.25	2.89	6.25	2.98	6.22	3.02	6.22	3.06	6.22	3.15
	-11.8	-13	6.53	2.88	6.53	2.96	6.50	3.04	6.50	3.08	6.50	3.12	6.47	3.20
	-9.8	-11	6.85	2.94	6.85	3.02	6.82	3.10	6.82	3.14	6.82	3.18	6.79	3.26
	-9.5	-10	7.02	2.98	6.99	3.05	6.99	3.13	6.96	3.17	6.96	3.21	6.96	3.28
	-8.5	-9.1	7.16	3.01	7.16	3.08	7.13	3.16	7.13	3.19	7.13	3.23	7.04	3.26
	-7	-7.6	7.42	3.06	7.42	3.13	7.39	3.20	7.39	3.24	7.39	3.27	7.04	3.11
	-5	-5.6	7.81	3.13	7.79	3.19	7.79	3.26	7.76	3.29	7.56	3.19	7.04	2.93
	-3	-3.7	8.19	3.19	8.19	3.25	8.10	3.26	7.81	3.13	7.56	3.01	7.04	2.76
	0	-0.7	8.87	3.28	8.61	3.20	8.10	2.96	7.81	2.84	7.56	2.73	7.04	2.51
	3	2.2	9.13	3.12	8.61	2.91	8.10	2.70	7.81	2.59	7.56	2.49	7.04	2.29
	5	4.1	9.13	2.94	8.61	2.73	8.10	2.54	7.81	2.44	7.56	2.35	7.04	2.16
	7	6	9.13	2.76	8.61	2.58	8.10	2.39	7.81	2.31	7.56	2.22	7.04	2.04
	9	7.9	9.13	2.60	8.61	2.42	8.10	2.26	7.81	2.17	7.56	2.09	7.04	1.93
	11	9.8	9.13	2.45	8.61	2.29	8.10	2.13	7.81	2.06	7.56	1.98	7.04	1.83
	13	11.8	9.13	2.31	8.61	2.16	8.10	2.01	7.81	1.94	7.56	1.87	7.04	1.73
15	13.7	9.13	2.18	8.61	2.04	8.10	1.90	7.81	1.84	7.56	1.77	7.04	1.64	
80%	-13.7	-15	6.26	2.97	6.23	3.05	6.23	3.13	6.23	3.16	6.20	3.20	6.20	3.28
	-11.8	-13	6.51	3.03	6.51	3.11	6.49	3.18	6.49	3.21	6.49	3.25	6.29	3.16
	-9.8	-11	6.83	3.09	6.83	3.16	6.80	3.23	6.80	3.27	6.74	3.26	6.29	2.99
	-9.5	-10	7.00	3.13	6.97	3.19	6.97	3.26	6.97	3.29	6.74	3.16	6.29	2.90
	-8.5	-9.1	7.14	3.15	6.64	3.22	7.11	3.28	6.97	3.21	6.74	3.08	6.29	2.82
	-7	-7.6	7.40	3.20	7.40	3.26	7.20	3.19	6.97	3.07	6.74	2.94	6.29	2.70
	-5	-5.6	7.80	3.26	7.66	3.24	7.20	3.00	6.97	2.88	6.74	2.77	6.29	2.54
	-3	-3.7	8.11	3.27	7.66	3.05	7.20	2.82	6.97	2.72	6.74	2.61	6.29	2.40
	0	-0.7	8.11	2.97	7.66	2.77	7.20	2.57	6.97	2.47	6.74	2.38	6.29	2.19
	3	2.2	8.11	2.71	7.66	2.52	7.20	2.35	6.97	2.26	6.74	2.17	6.29	2.01
	5	4.1	8.11	2.55	7.66	2.38	7.20	2.21	6.97	2.13	6.74	2.06	6.29	1.90
	7	6	8.11	2.40	7.66	2.25	7.20	2.09	6.97	2.02	6.74	1.94	6.29	1.79
	9	7.9	8.11	2.27	7.66	2.12	7.20	1.97	6.97	1.90	6.74	1.84	6.29	1.70
	11	9.8	8.11	2.14	7.66	2.00	7.20	1.87	6.97	1.80	6.74	1.74	6.29	1.61
	13	11.8	8.11	2.02	7.66	1.89	7.20	1.77	6.97	1.70	6.74	1.64	6.29	1.52
15	13.7	8.11	1.91	7.66	1.79	7.20	1.68	6.97	1.62	6.74	1.56	6.29	1.45	
70%	-13.7	-15	6.21	3.14	6.19	3.21	6.19	3.27	6.07	3.22	5.87	3.09	5.47	2.84
	-11.8	-13	6.47	3.19	6.47	3.26	6.30	3.18	6.07	3.05	5.87	2.93	5.47	2.69
	-9.8	-11	6.78	3.24	6.70	3.24	6.30	3.00	6.07	2.89	5.87	2.77	5.47	2.54
	-9.5	-10	6.96	3.27	6.70	3.15	6.30	2.91	6.07	2.80	5.87	2.69	5.47	2.47
	-8.5	-9.1	7.10	3.29	6.70	3.06	6.30	2.84	6.07	2.73	5.87	2.62	5.47	2.41
	-7	-7.6	7.10	3.14	6.70	2.92	6.30	2.71	6.07	2.61	5.87	2.51	5.47	2.31
	-5	-5.6	7.10	2.95	6.70	2.75	6.30	2.56	6.07	2.46	5.87	2.40	5.47	2.18
	-3	-3.7	7.10	2.78	6.70	2.59	6.30	2.41	6.07	2.32	5.87	2.23	5.47	2.06
	0	-0.7	7.10	2.53	6.70	2.36	6.30	2.20	6.07	2.12	5.87	2.04	5.47	1.89
	3	2.2	7.10	2.31	6.70	2.16	6.30	2.02	6.07	1.94	5.87	1.87	5.47	1.73
	5	4.1	7.10	2.18	6.70	2.04	6.30	1.91	6.07	1.84	5.87	1.77	5.47	1.64
7	6	7.10	2.06	6.70	1.93	6.30	1.80	6.07	1.74	5.87	1.68	5.47	1.56	
9	7.9	7.10	1.95	6.70	1.83	6.30	1.71	6.07	1.65	5.87	1.59	5.47	1.47	

	11	9.8	7.10	1.84	6.70	1.73	6.30	1.62	6.07	1.56	5.87	1.51	5.47	1.40
	13	11.8	7.10	1.74	6.70	1.64	6.30	1.53	6.07	1.48	5.87	1.43	5.47	1.33
	15	13.7	7.10	1.65	6.70	1.55	6.30	1.45	6.07	1.41	5.87	1.36	5.47	1.27
60%	-13.7	-15	6.09	3.22	5.74	3.00	5.40	2.78	5.23	2.67	5.06	2.57	4.71	2.36
	-11.8	-13	6.09	3.05	5.74	2.84	5.40	2.64	5.23	2.54	5.06	2.44	4.71	2.26
	-9.8	-11	6.09	2.88	5.74	2.69	5.40	2.50	5.23	2.40	5.06	2.31	4.71	2.13
	-9.5	-10	6.09	2.80	5.74	2.61	5.40	2.42	5.23	2.34	5.06	2.25	4.71	2.07
	-8.5	-9.1	6.09	2.73	5.74	2.54	5.40	2.36	5.23	2.28	5.06	2.19	4.71	2.02
	-7	-7.6	6.09	2.61	5.74	2.44	5.40	2.26	5.23	2.18	5.06	2.10	4.71	1.94
	-5	-5.6	6.09	2.46	5.74	2.29	5.40	2.14	5.23	2.06	5.06	1.98	4.71	1.83
	-3	-3.7	6.09	2.32	5.74	2.17	5.40	2.02	5.23	1.95	5.06	1.88	4.71	1.73
	0	-0.7	6.09	2.12	5.74	1.98	5.40	1.85	5.23	1.79	5.06	1.72	4.71	1.59
	3	2.2	6.09	1.94	5.74	1.82	5.40	1.70	5.23	1.64	5.06	1.59	4.71	1.47
	5	4.1	6.09	1.84	5.74	1.72	5.40	1.61	5.23	1.56	5.06	1.50	4.71	1.40
	7	6	6.09	1.74	5.74	1.63	5.40	1.53	5.23	1.48	5.06	1.43	4.71	1.33
	9	7.9	6.09	1.65	5.74	1.55	5.40	1.45	5.23	1.40	5.06	1.35	4.71	1.26
	11	9.8	6.09	1.56	5.74	1.47	5.40	1.38	5.23	1.33	5.06	1.29	4.71	1.20
	13	11.8	6.09	1.48	5.74	1.39	5.40	1.31	5.23	1.27	5.06	1.22	4.71	1.14
15	13.7	6.09	1.41	5.74	1.32	5.40	1.25	5.23	1.21	5.06	1.17	4.71	1.09	
50%	-13.7	-15	5.07	2.58	4.78	2.41	4.50	2.24	4.33	2.16	4.19	2.08	3.90	1.92
	-11.8	-13	5.07	2.45	4.78	2.29	4.50	2.13	4.33	2.06	4.19	1.98	3.90	1.83
	-9.8	-11	5.07	2.32	4.78	2.17	4.50	2.02	4.33	1.95	4.19	1.88	3.90	1.74
	-9.5	-10	5.07	2.26	4.78	2.11	4.50	1.97	4.33	1.90	4.19	1.83	3.90	1.69
	-8.5	-9.1	5.07	2.20	4.78	2.06	4.50	1.92	4.33	1.85	4.19	1.79	3.90	1.65
	-7	-7.6	5.07	2.11	4.78	1.98	4.50	1.84	4.33	1.78	4.19	1.72	3.90	1.59
	-5	-5.6	5.07	1.99	4.78	1.87	4.50	1.75	4.33	1.69	4.19	1.63	3.90	1.51
	-3	-3.7	5.07	1.89	4.78	1.77	4.50	1.65	4.33	1.60	4.19	1.54	3.90	1.43
	0	-0.7	5.07	1.73	4.78	1.63	4.50	1.52	4.33	1.47	4.19	1.42	3.90	1.32
	3	2.2	5.07	1.59	4.78	1.50	4.50	1.40	4.33	1.36	4.19	1.31	3.90	1.22
	5	4.1	5.07	1.51	4.78	1.42	4.50	1.33	4.33	1.29	4.19	1.25	3.90	1.16
	7	6	5.07	1.44	4.78	1.35	4.50	1.27	4.33	1.23	4.19	1.19	3.90	1.11
	9	7.9	5.07	1.36	4.78	1.28	4.50	1.21	4.33	1.17	4.19	1.13	3.90	1.06
	11	9.8	5.07	1.30	4.78	1.22	4.50	1.15	4.33	1.12	4.19	1.08	3.90	1.01
	13	11.8	5.07	1.23	4.78	1.16	4.50	1.09	4.33	1.06	4.19	1.03	3.90	0.96
15	13.7	5.07	1.17	4.78	1.11	4.50	1.05	4.33	1.01	4.19	0.98	3.90	0.92	

MDV-V105W/N1 MDV-V105W/N1-B

Cooling

Combination (%) (Capacity index)	Outdoor temperature(°C DB)	Indoor temperature(°C WB)													
		14.00		16.00		18.00		19.00		20.00		22.00		24.00	
		TC	PI	TC	PI	TC	PI	TC	PI	TC	PI	TC	PI	TC	PI
		kW	kW	kW	kW	kW	kW	kW	kW	kW	kW	kW	kW	kW	kW
130%	10.00	7.97	1.19	9.41	1.48	10.85	1.77	11.51	1.92	12.17	2.07	12.44	2.08	12.70	2.10
	12.00	7.97	1.21	9.41	1.51	10.85	1.81	11.51	1.96	12.17	2.11	12.44	2.12	12.70	2.14
	14.00	7.97	1.23	9.41	1.54	10.85	1.84	11.51	1.99	12.17	2.15	12.44	2.16	12.70	2.18
	16.00	7.97	1.25	9.41	1.56	10.85	1.87	11.51	2.03	12.17	2.19	12.44	2.19	12.70	2.22
	18.00	7.97	1.28	9.41	1.59	10.85	1.90	11.51	2.07	12.17	2.23	12.44	2.23	12.70	2.26
	19.00	7.97	1.30	9.41	1.62	10.85	1.94	11.51	2.10	12.17	2.27	12.44	2.27	12.70	2.29
	21.00	7.97	1.39	9.41	1.73	10.85	2.08	11.51	2.25	12.17	2.43	12.44	2.44	12.70	2.46
	23.00	7.97	1.49	9.41	1.86	10.85	2.22	11.51	2.41	12.17	2.60	12.44	2.61	12.70	2.63
	25.00	7.97	1.60	9.41	1.99	10.85	2.38	11.51	2.58	12.17	2.78	12.44	2.79	12.70	2.82
	27.00	7.97	1.71	9.41	2.13	10.85	2.54	11.51	2.76	12.17	2.98	12.44	2.98	12.70	3.01
	29.00	7.97	1.82	9.41	2.27	10.85	2.72	11.51	2.95	12.17	3.18	12.44	3.19	12.70	3.22
	31.00	7.97	1.94	9.41	2.42	10.85	2.90	11.51	3.14	12.17	3.39	12.44	3.40	12.70	3.43
	33.00	7.97	2.07	9.41	2.58	10.85	3.09	11.51	3.35	12.17	3.61	12.44	3.62	12.70	3.65
	35.00	7.97	2.20	9.41	2.74	10.85	3.28	11.51	3.56	12.17	3.84	12.44	3.85	12.70	3.89
	37.00	7.97	2.34	9.41	2.92	10.85	3.49	11.51	3.79	12.17	4.08	12.44	4.10	12.70	4.14
	39.00	7.97	2.35	9.41	2.93	10.85	3.51	11.51	3.80	12.17	4.10	12.44	4.11	12.70	4.15
41.00	7.97	2.36	9.41	2.94	10.85	3.52	11.51	3.82	12.17	4.12	12.44	4.13	12.70	4.17	
43.00	7.97	2.37	9.41	2.96	10.85	3.54	11.51	3.84	12.17	4.14	12.44	4.15	12.70	4.19	
120%	10.00	7.84	1.18	9.26	1.47	10.67	1.76	11.32	1.90	11.98	2.05	12.24	2.06	12.50	2.08
	12.00	7.84	1.20	9.26	1.49	10.67	1.79	11.32	1.94	11.98	2.09	12.24	2.10	12.50	2.12
	14.00	7.84	1.22	9.26	1.52	10.67	1.82	11.32	1.98	11.98	2.13	12.24	2.14	12.50	2.16
	16.00	7.84	1.24	9.26	1.55	10.67	1.85	11.32	2.01	11.98	2.17	12.24	2.17	12.50	2.19
	18.00	7.84	1.26	9.26	1.58	10.67	1.89	11.32	2.05	11.98	2.21	12.24	2.21	12.50	2.23
	19.00	7.84	1.29	9.26	1.60	10.67	1.92	11.32	2.08	11.98	2.24	12.24	2.25	12.50	2.27
	21.00	7.84	1.38	9.26	1.72	10.67	2.06	11.32	2.23	11.98	2.40	12.24	2.41	12.50	2.44
	23.00	7.84	1.48	9.26	1.84	10.67	2.20	11.32	2.39	11.98	2.58	12.24	2.58	12.50	2.61
	25.00	7.84	1.58	9.26	1.97	10.67	2.36	11.32	2.56	11.98	2.76	12.24	2.76	12.50	2.79
	27.00	7.84	1.69	9.26	2.10	10.67	2.52	11.32	2.73	11.98	2.95	12.24	2.96	12.50	2.98
	29.00	7.84	1.80	9.26	2.25	10.67	2.69	11.32	2.92	11.98	3.15	12.24	3.16	12.50	3.19
	31.00	7.84	1.92	9.26	2.40	10.67	2.87	11.32	3.11	11.98	3.36	12.24	3.37	12.50	3.40
	33.00	7.84	2.05	9.26	2.55	10.67	3.06	11.32	3.32	11.98	3.57	12.24	3.58	12.50	3.62
	35.00	7.84	2.18	9.26	2.72	10.67	3.25	11.32	3.53	11.98	3.80	12.24	3.81	12.50	3.85
	37.00	7.84	2.32	9.26	2.89	10.67	3.46	11.32	3.75	11.98	4.04	12.24	4.06	12.50	4.10
	39.00	7.84	2.33	9.26	2.90	10.67	3.47	11.32	3.77	11.98	4.06	12.24	4.07	12.50	4.11
41.00	7.84	2.34	9.26	2.91	10.67	3.49	11.32	3.78	11.98	4.08	12.24	4.09	12.50	4.13	
43.00	7.84	2.35	9.26	2.93	10.67	3.51	11.32	3.80	11.98	4.10	12.24	4.11	12.50	4.15	
110%	10.00	7.71	1.17	9.10	1.45	10.50	1.74	11.14	1.89	11.78	2.03	12.03	2.04	12.29	2.06
	12.00	7.71	1.19	9.10	1.48	10.50	1.77	11.14	1.92	11.78	2.07	12.03	2.08	12.29	2.10
	14.00	7.71	1.21	9.10	1.51	10.50	1.80	11.14	1.96	11.78	2.11	12.03	2.11	12.29	2.14
	16.00	7.71	1.23	9.10	1.53	10.50	1.84	11.14	1.99	11.78	2.15	12.03	2.15	12.29	2.17
	18.00	7.71	1.25	9.10	1.56	10.50	1.87	11.14	2.03	11.78	2.18	12.03	2.19	12.29	2.21
	19.00	7.71	1.27	9.10	1.59	10.50	1.90	11.14	2.06	11.78	2.22	12.03	2.23	12.29	2.25
	21.00	7.71	1.37	9.10	1.70	10.50	2.04	11.14	2.21	11.78	2.38	12.03	2.39	12.29	2.41
	23.00	7.71	1.46	9.10	1.82	10.50	2.18	11.14	2.37	11.78	2.55	12.03	2.56	12.29	2.58
	25.00	7.71	1.56	9.10	1.95	10.50	2.33	11.14	2.53	11.78	2.73	12.03	2.74	12.29	2.76
	27.00	7.71	1.67	9.10	2.08	10.50	2.50	11.14	2.71	11.78	2.92	12.03	2.93	12.29	2.96
	29.00	7.71	1.79	9.10	2.23	10.50	2.66	11.14	2.89	11.78	3.12	12.03	3.13	12.29	3.16
	31.00	7.71	1.90	9.10	2.37	10.50	2.84	11.14	3.08	11.78	3.32	12.03	3.33	12.29	3.37
	33.00	7.71	2.03	9.10	2.53	10.50	3.03	11.14	3.28	11.78	3.54	12.03	3.55	12.29	3.58
	35.00	7.71	2.16	9.10	2.69	10.50	3.22	11.14	3.49	11.78	3.77	12.03	3.78	12.29	3.81

	37.00	7.71	2.30	9.10	2.86	10.50	3.43	11.14	3.71	11.78	4.00	12.03	4.02	12.29	4.06	
	39.00	7.71	2.31	9.10	2.87	10.50	3.44	11.14	3.73	11.78	4.02	12.03	4.03	12.29	4.07	
	41.00	7.71	2.32	9.10	2.89	10.50	3.46	11.14	3.75	11.78	4.04	12.03	4.05	12.29	4.09	
	43.00	7.71	2.33	9.10	2.90	10.50	3.47	11.14	3.77	11.78	4.06	12.03	4.07	12.29	4.11	
100%	10.00	7.27	1.09	8.58	1.36	9.90	1.62	10.50	1.76	11.10	1.90	11.35	1.90	11.59	1.92	
	12.00	7.27	1.11	8.58	1.38	9.90	1.65	10.50	1.79	11.10	1.93	11.35	1.94	11.59	1.96	
	14.00	7.27	1.13	8.58	1.41	9.90	1.68	10.50	1.83	11.10	1.97	11.35	1.97	11.59	1.99	
	16.00	7.27	1.15	8.58	1.43	9.90	1.71	10.50	1.86	11.10	2.00	11.35	2.01	11.59	2.03	
	18.00	7.27	1.17	8.58	1.46	9.90	1.74	10.50	1.89	11.10	2.04	11.35	2.04	11.59	2.06	
	19.00	7.27	1.19	8.58	1.48	9.90	1.77	10.50	1.92	11.10	2.07	11.35	2.08	11.59	2.10	
	21.00	7.27	1.27	8.58	1.59	9.90	1.90	10.50	2.06	11.10	2.22	11.35	2.23	11.59	2.25	
	23.00	7.27	1.36	8.58	1.70	9.90	2.04	10.50	2.21	11.10	2.38	11.35	2.39	11.59	2.41	
	25.00	7.27	1.46	8.58	1.82	9.90	2.18	10.50	2.36	11.10	2.55	11.35	2.56	11.59	2.58	
	27.00	7.27	1.56	8.58	1.95	9.90	2.33	10.50	2.53	11.10	2.72	11.35	2.73	11.59	2.76	
	29.00	7.27	1.67	8.58	2.08	9.90	2.49	10.50	2.70	11.10	2.91	11.35	2.92	11.59	2.95	
	31.00	7.27	1.78	8.58	2.22	9.90	2.65	10.50	2.88	11.10	3.10	11.35	3.11	11.59	3.14	
	33.00	7.27	1.89	8.58	2.36	9.90	2.83	10.50	3.06	11.10	3.30	11.35	3.31	11.59	3.35	
	35.00	7.27	2.01	8.58	2.51	9.90	3.01	10.50	3.26	11.10	3.51	11.35	3.53	11.59	3.56	
	37.00	7.27	2.14	8.58	2.67	9.90	3.20	10.50	3.47	11.10	3.74	11.35	3.75	11.59	3.79	
	39.00	7.27	2.15	8.58	2.68	9.90	3.21	10.50	3.48	11.10	3.75	11.35	3.77	11.59	3.80	
	41.00	7.27	2.16	8.58	2.69	9.90	3.23	10.50	3.50	11.10	3.77	11.35	3.78	11.59	3.82	
	43.00	7.27	2.17	8.58	2.71	9.90	3.24	10.50	3.51	11.10	3.79	11.35	3.80	11.59	3.84	
	90%	10.00	6.54	0.94	7.73	1.17	8.91	1.40	9.45	1.52	9.99	1.64	10.21	1.65	10.43	1.66
		12.00	6.54	0.96	7.73	1.19	8.91	1.43	9.45	1.55	9.99	1.67	10.21	1.68	10.43	1.69
14.00		6.54	0.98	7.73	1.22	8.91	1.46	9.45	1.58	9.99	1.70	10.21	1.71	10.43	1.72	
16.00		6.54	0.99	7.73	1.24	8.91	1.48	9.45	1.61	9.99	1.73	10.21	1.74	10.43	1.75	
18.00		6.54	1.01	7.73	1.26	8.91	1.51	9.45	1.63	9.99	1.76	10.21	1.77	10.43	1.78	
19.00		6.54	1.03	7.73	1.28	8.91	1.53	9.45	1.66	9.99	1.79	10.21	1.80	10.43	1.82	
21.00		6.54	1.10	7.73	1.37	8.91	1.64	9.45	1.78	9.99	1.92	10.21	1.93	10.43	1.95	
23.00		6.54	1.18	7.73	1.47	8.91	1.76	9.45	1.91	9.99	2.06	10.21	2.06	10.43	2.08	
25.00		6.54	1.26	7.73	1.57	8.91	1.88	9.45	2.04	9.99	2.20	10.21	2.21	10.43	2.23	
27.00		6.54	1.35	7.73	1.68	8.91	2.01	9.45	2.18	9.99	2.35	10.21	2.36	10.43	2.38	
29.00		6.54	1.44	7.73	1.80	8.91	2.15	9.45	2.33	9.99	2.51	10.21	2.52	10.43	2.55	
31.00		6.54	1.54	7.73	1.92	8.91	2.29	9.45	2.49	9.99	2.68	10.21	2.69	10.43	2.72	
33.00		6.54	1.64	7.73	2.04	8.91	2.44	9.45	2.65	9.99	2.86	10.21	2.86	10.43	2.89	
35.00		6.54	1.74	7.73	2.17	8.91	2.60	9.45	2.82	9.99	3.04	10.21	3.05	10.43	3.08	
37.00		6.54	1.85	7.73	2.31	8.91	2.76	9.45	3.00	9.99	3.23	10.21	3.24	10.43	3.27	
39.00	6.54	1.86	7.73	2.32	8.91	2.78	9.45	3.01	9.99	3.25	10.21	3.26	10.43	3.29		
41.00	6.54	1.87	7.73	2.33	8.91	2.79	9.45	3.02	9.99	3.26	10.21	3.27	10.43	3.30		
43.00	6.54	1.88	7.73	2.34	8.91	2.80	9.45	3.04	9.99	3.28	10.21	3.29	10.43	3.32		
80%	10.00	5.82	0.80	6.87	1.00	7.92	1.20	8.40	1.30	8.88	1.40	9.08	1.41	9.27	1.42	
	12.00	5.82	0.82	6.87	1.02	7.92	1.22	8.40	1.32	8.88	1.43	9.08	1.43	9.27	1.45	
	14.00	5.82	0.83	6.87	1.04	7.92	1.24	8.40	1.35	8.88	1.45	9.08	1.46	9.27	1.47	
	16.00	5.82	0.85	6.87	1.06	7.92	1.27	8.40	1.37	8.88	1.48	9.08	1.48	9.27	1.50	
	18.00	5.82	0.86	6.87	1.08	7.92	1.29	8.40	1.40	8.88	1.51	9.08	1.51	9.27	1.52	
	19.00	5.82	0.88	6.87	1.09	7.92	1.31	8.40	1.42	8.88	1.53	9.08	1.54	9.27	1.55	
	21.00	5.82	0.94	6.87	1.17	7.92	1.40	8.40	1.52	8.88	1.64	9.08	1.65	9.27	1.66	
	23.00	5.82	1.01	6.87	1.26	7.92	1.50	8.40	1.63	8.88	1.76	9.08	1.76	9.27	1.78	
	25.00	5.82	1.08	6.87	1.34	7.92	1.61	8.40	1.75	8.88	1.88	9.08	1.89	9.27	1.91	
	27.00	5.82	1.15	6.87	1.44	7.92	1.72	8.40	1.87	8.88	2.01	9.08	2.02	9.27	2.04	
	29.00	5.82	1.23	6.87	1.53	7.92	1.84	8.40	1.99	8.88	2.15	9.08	2.15	9.27	2.17	
	31.00	5.82	1.31	6.87	1.64	7.92	1.96	8.40	2.12	8.88	2.29	9.08	2.30	9.27	2.32	
	33.00	5.82	1.40	6.87	1.74	7.92	2.09	8.40	2.26	8.88	2.44	9.08	2.45	9.27	2.47	
	35.00	5.82	1.49	6.87	1.85	7.92	2.22	8.40	2.41	8.88	2.60	9.08	2.60	9.27	2.63	
	37.00	5.82	1.58	6.87	1.97	7.92	2.36	8.40	2.56	8.88	2.76	9.08	2.77	9.27	2.80	
39.00	5.82	1.59	6.87	1.98	7.92	2.37	8.40	2.57	8.88	2.77	9.08	2.78	9.27	2.81		
41.00	5.82	1.60	6.87	1.99	7.92	2.38	8.40	2.58	8.88	2.78	9.08	2.79	9.27	2.82		
43.00	5.82	1.60	6.87	2.00	7.92	2.39	8.40	2.60	8.88	2.80	9.08	2.81	9.27	2.83		

70%	10.00	5.09	0.68	6.01	0.84	6.93	1.01	7.35	1.09	7.77	1.18	7.94	1.18	8.11	1.20
	12.00	5.09	0.69	6.01	0.86	6.93	1.03	7.35	1.11	7.77	1.20	7.94	1.21	8.11	1.22
	14.00	5.09	0.70	6.01	0.87	6.93	1.05	7.35	1.14	7.77	1.22	7.94	1.23	8.11	1.24
	16.00	5.09	0.71	6.01	0.89	6.93	1.07	7.35	1.16	7.77	1.25	7.94	1.25	8.11	1.26
	18.00	5.09	0.73	6.01	0.91	6.93	1.08	7.35	1.18	7.77	1.27	7.94	1.27	8.11	1.28
	19.00	5.09	0.74	6.01	0.92	6.93	1.10	7.35	1.20	7.77	1.29	7.94	1.29	8.11	1.31
	21.00	5.09	0.79	6.01	0.99	6.93	1.18	7.35	1.28	7.77	1.38	7.94	1.39	8.11	1.40
	23.00	5.09	0.85	6.01	1.06	6.93	1.27	7.35	1.37	7.77	1.48	7.94	1.49	8.11	1.50
	25.00	5.09	0.91	6.01	1.13	6.93	1.36	7.35	1.47	7.77	1.58	7.94	1.59	8.11	1.60
	27.00	5.09	0.97	6.01	1.21	6.93	1.45	7.35	1.57	7.77	1.69	7.94	1.70	8.11	1.72
	29.00	5.09	1.04	6.01	1.29	6.93	1.55	7.35	1.68	7.77	1.81	7.94	1.81	8.11	1.83
	31.00	5.09	1.11	6.01	1.38	6.93	1.65	7.35	1.79	7.77	1.93	7.94	1.93	8.11	1.95
	33.00	5.09	1.18	6.01	1.47	6.93	1.76	7.35	1.91	7.77	2.05	7.94	2.06	8.11	2.08
	35.00	5.09	1.25	6.01	1.56	6.93	1.87	7.35	2.03	7.77	2.19	7.94	2.19	8.11	2.21
	37.00	5.09	1.33	6.01	1.66	6.93	1.99	7.35	2.16	7.77	2.32	7.94	2.33	8.11	2.35
	39.00	5.09	1.34	6.01	1.67	6.93	2.00	7.35	2.17	7.77	2.33	7.94	2.34	8.11	2.36
41.00	5.09	1.34	6.01	1.67	6.93	2.01	7.35	2.18	7.77	2.34	7.94	2.35	8.11	2.37	
43.00	5.09	1.35	6.01	1.68	6.93	2.01	7.35	2.19	7.77	2.36	7.94	2.36	8.11	2.39	
60%	10.00	4.36	0.56	5.15	0.70	5.94	0.84	6.30	0.91	6.66	0.98	6.81	0.98	6.95	0.99
	12.00	4.36	0.57	5.15	0.71	5.94	0.85	6.30	0.92	6.66	0.99	6.81	1.00	6.95	1.01
	14.00	4.36	0.58	5.15	0.72	5.94	0.87	6.30	0.94	6.66	1.01	6.81	1.02	6.95	1.03
	16.00	4.36	0.59	5.15	0.74	5.94	0.88	6.30	0.96	6.66	1.03	6.81	1.03	6.95	1.04
	18.00	4.36	0.60	5.15	0.75	5.94	0.90	6.30	0.97	6.66	1.05	6.81	1.05	6.95	1.06
	19.00	4.36	0.61	5.15	0.76	5.94	0.91	6.30	0.99	6.66	1.07	6.81	1.07	6.95	1.08
	21.00	4.36	0.66	5.15	0.82	5.94	0.98	6.30	1.06	6.66	1.14	6.81	1.15	6.95	1.16
	23.00	4.36	0.70	5.15	0.88	5.94	1.05	6.30	1.14	6.66	1.23	6.81	1.23	6.95	1.24
	25.00	4.36	0.75	5.15	0.94	5.94	1.12	6.30	1.22	6.66	1.31	6.81	1.32	6.95	1.33
	27.00	4.36	0.80	5.15	1.00	5.94	1.20	6.30	1.30	6.66	1.40	6.81	1.41	6.95	1.42
	29.00	4.36	0.86	5.15	1.07	5.94	1.28	6.30	1.39	6.66	1.50	6.81	1.50	6.95	1.52
	31.00	4.36	0.92	5.15	1.14	5.94	1.37	6.30	1.48	6.66	1.60	6.81	1.60	6.95	1.62
	33.00	4.36	0.97	5.15	1.21	5.94	1.45	6.30	1.58	6.66	1.70	6.81	1.71	6.95	1.72
	35.00	4.36	1.04	5.15	1.29	5.94	1.55	6.30	1.68	6.66	1.81	6.81	1.81	6.95	1.83
	37.00	4.36	1.10	5.15	1.37	5.94	1.65	6.30	1.78	6.66	1.92	6.81	1.93	6.95	1.95
	39.00	4.36	1.11	5.15	1.38	5.94	1.65	6.30	1.79	6.66	1.93	6.81	1.94	6.95	1.96
41.00	4.36	1.11	5.15	1.39	5.94	1.66	6.30	1.80	6.66	1.94	6.81	1.95	6.95	1.97	
43.00	4.36	1.12	5.15	1.39	5.94	1.67	6.30	1.81	6.66	1.95	6.81	1.96	6.95	1.97	
50%	10.00	3.64	0.45	4.29	0.57	4.95	0.68	5.25	0.73	5.55	0.79	5.67	0.79	5.79	0.80
	12.00	3.64	0.46	4.29	0.58	4.95	0.69	5.25	0.75	5.55	0.81	5.67	0.81	5.79	0.82
	14.00	3.64	0.47	4.29	0.59	4.95	0.70	5.25	0.76	5.55	0.82	5.67	0.82	5.79	0.83
	16.00	3.64	0.48	4.29	0.60	4.95	0.71	5.25	0.77	5.55	0.84	5.67	0.84	5.79	0.85
	18.00	3.64	0.49	4.29	0.61	4.95	0.73	5.25	0.79	5.55	0.85	5.67	0.85	5.79	0.86
	19.00	3.64	0.50	4.29	0.62	4.95	0.74	5.25	0.80	5.55	0.86	5.67	0.87	5.79	0.88
	21.00	3.64	0.53	4.29	0.66	4.95	0.79	5.25	0.86	5.55	0.93	5.67	0.93	5.79	0.94
	23.00	3.64	0.57	4.29	0.71	4.95	0.85	5.25	0.92	5.55	0.99	5.67	1.00	5.79	1.01
	25.00	3.64	0.61	4.29	0.76	4.95	0.91	5.25	0.99	5.55	1.06	5.67	1.07	5.79	1.08
	27.00	3.64	0.65	4.29	0.81	4.95	0.97	5.25	1.05	5.55	1.14	5.67	1.14	5.79	1.15
	29.00	3.64	0.70	4.29	0.87	4.95	1.04	5.25	1.12	5.55	1.21	5.67	1.22	5.79	1.23
	31.00	3.64	0.74	4.29	0.92	4.95	1.11	5.25	1.20	5.55	1.29	5.67	1.30	5.79	1.31
	33.00	3.64	0.79	4.29	0.98	4.95	1.18	5.25	1.28	5.55	1.38	5.67	1.38	5.79	1.40
	35.00	3.64	0.84	4.29	1.05	4.95	1.25	5.25	1.36	5.55	1.47	5.67	1.47	5.79	1.48
	37.00	3.64	0.89	4.29	1.11	4.95	1.33	5.25	1.45	5.55	1.56	5.67	1.56	5.79	1.58
	39.00	3.64	0.90	4.29	1.12	4.95	1.34	5.25	1.45	5.55	1.57	5.67	1.57	5.79	1.59
41.00	3.64	0.90	4.29	1.12	4.95	1.34	5.25	1.46	5.55	1.57	5.67	1.58	5.79	1.59	
43.00	3.64	0.91	4.29	1.13	4.95	1.35	5.25	1.47	5.55	1.58	5.67	1.58	5.79	1.60	



Heating

Combination (Capacity index)	Outdoor air temp.		Indoor temperature(°C DB)											
			16		18		20		21		22		24	
	°C DB	°C WB	TC	PI	TC	PI	TC	PI	TC	PI	TC	PI	TC	PI
			kW	kW	kW	kW	kW	kW	kW	kW	kW	kW	kW	kW
130%	-14.7	-15	8.52	2.96	8.52	3.03	8.52	3.09	8.18	2.95	7.84	2.82	7.17	2.55
	-12.6	-13	8.99	3.01	8.99	3.08	8.99	3.14	8.64	3.00	8.28	2.87	7.57	2.59
	-10.5	-11	9.47	3.06	9.47	3.13	9.47	3.19	9.09	3.05	8.72	2.91	7.97	2.63
	-9.5	-10	9.69	3.08	9.69	3.15	9.69	3.22	9.31	3.08	8.93	2.93	8.16	2.65
	-8.5	-9.1	9.92	3.11	9.92	3.17	9.92	3.24	9.53	3.10	9.13	2.96	8.35	2.67
	-7	-7.6	10.26	3.14	10.26	3.21	10.26	3.28	9.85	3.13	9.44	2.99	8.63	2.70
	-5	-5.6	10.71	3.19	10.71	3.26	10.71	3.33	10.29	3.18	9.86	3.03	9.01	2.74
	-3	-3.7	11.16	3.24	11.16	3.31	11.16	3.37	10.72	3.23	10.28	3.08	9.39	2.78
	0	-0.7	11.84	3.31	11.84	3.38	11.84	3.45	11.37	3.30	10.90	3.15	9.96	2.84
	3	2.2	12.52	3.38	12.52	3.45	12.52	3.52	12.02	3.37	11.52	3.21	10.53	2.90
	5	4.1	12.97	3.42	12.97	3.50	12.97	3.57	12.45	3.41	11.94	3.26	10.91	2.94
	7	6	13.42	3.47	13.42	3.54	13.42	3.62	12.89	3.46	12.35	3.30	11.29	2.98
	9	7.9	13.42	3.35	13.42	3.42	13.42	3.50	12.89	3.34	12.35	3.19	11.29	2.88
	11	9.8	13.42	3.24	13.42	3.31	13.42	3.37	12.89	3.23	12.35	3.08	11.29	2.78
	13	11.8	13.42	3.12	13.42	3.19	13.42	3.25	12.89	3.11	12.35	2.97	11.29	2.68
15	13.7	13.42	3.00	13.42	3.07	13.42	3.13	12.89	2.99	12.35	2.86	11.29	2.58	
120%	-14.7	-15	8.52	3.05	8.52	3.12	8.52	3.18	8.18	3.04	7.84	2.90	7.17	2.62
	-12.6	-13	8.99	3.10	8.99	3.17	8.99	3.23	8.64	3.09	8.28	2.95	7.57	2.67
	-10.5	-11	9.47	3.15	9.47	3.22	9.47	3.29	9.09	3.14	8.72	3.00	7.97	2.71
	-9.5	-10	9.69	3.18	9.69	3.24	9.69	3.31	9.31	3.17	8.93	3.02	8.16	2.73
	-8.5	-9.1	9.92	3.20	9.92	3.27	9.92	3.34	9.53	3.19	9.13	3.04	8.35	2.75
	-7	-7.6	10.26	3.24	10.26	3.30	10.26	3.37	9.85	3.23	9.44	3.08	8.63	2.78
	-5	-5.6	10.71	3.28	10.71	3.35	10.71	3.42	10.29	3.27	9.86	3.12	9.01	2.82
	-3	-3.7	11.16	3.33	11.16	3.40	11.16	3.47	10.72	3.32	10.28	3.17	9.39	2.87
	0	-0.7	11.84	3.40	11.84	3.48	11.84	3.55	11.37	3.39	10.90	3.24	9.96	2.93
	3	2.2	12.52	3.48	12.52	3.55	12.52	3.62	12.02	3.47	11.52	3.31	10.53	2.99
	5	4.1	12.97	3.52	12.97	3.60	12.97	3.67	12.45	3.51	11.94	3.35	10.91	3.03
	7	6	13.42	3.57	13.42	3.65	13.42	3.72	12.89	3.56	12.35	3.40	11.29	3.07
	9	7.9	13.42	3.45	13.42	3.53	13.42	3.60	12.89	3.44	12.35	3.28	11.29	2.97
	11	9.8	13.42	3.33	13.42	3.40	13.42	3.47	12.89	3.32	12.35	3.17	11.29	2.87
	13	11.8	13.42	3.21	13.42	3.28	13.42	3.35	12.89	3.20	12.35	3.06	11.29	2.76
15	13.7	13.42	3.09	13.42	3.16	13.42	3.22	12.89	3.08	12.35	2.94	11.29	2.66	
110%	-14.7	-15	8.52	3.14	8.52	3.21	8.52	3.27	8.18	3.13	7.84	2.99	7.17	2.70
	-12.6	-13	8.99	3.19	8.99	3.26	8.99	3.33	8.64	3.18	8.28	3.03	7.57	2.74
	-10.5	-11	9.47	3.24	9.47	3.31	9.47	3.38	9.09	3.23	8.72	3.08	7.97	2.79
	-9.5	-10	9.69	3.27	9.69	3.34	9.69	3.41	9.31	3.26	8.93	3.11	8.16	2.81
	-8.5	-9.1	9.92	3.29	9.92	3.36	9.92	3.43	9.53	3.28	9.13	3.13	8.35	2.83
	-7	-7.6	10.26	3.33	10.26	3.40	10.26	3.47	9.85	3.32	9.44	3.17	8.63	2.86
	-5	-5.6	10.71	3.38	10.71	3.45	10.71	3.52	10.29	3.37	9.86	3.21	9.01	2.90
	-3	-3.7	11.16	3.43	11.16	3.50	11.16	3.57	10.72	3.42	10.28	3.26	9.39	2.95
	0	-0.7	11.84	3.50	11.84	3.58	11.84	3.65	11.37	3.49	10.90	3.33	9.96	3.01
	3	2.2	12.52	3.58	12.52	3.65	12.52	3.73	12.02	3.56	11.52	3.40	10.53	3.07
	5	4.1	12.97	3.62	12.97	3.70	12.97	3.78	12.45	3.61	11.94	3.45	10.91	3.12
	7	6	13.42	3.67	13.42	3.75	13.42	3.83	12.89	3.66	12.35	3.49	11.29	3.16
	9	7.9	13.42	3.55	13.42	3.63	13.42	3.70	12.89	3.54	12.35	3.38	11.29	3.05
	11	9.8	13.42	3.43	13.42	3.50	13.42	3.57	12.89	3.42	12.35	3.26	11.29	2.95
	13	11.8	13.42	3.30	13.42	3.37	13.42	3.44	12.89	3.29	12.35	3.14	11.29	2.84
15	13.7	13.42	3.18	13.42	3.25	13.42	3.32	12.89	3.17	12.35	3.03	11.29	2.73	
100%	-14.7	-15	7.75	2.77	7.75	2.83	7.75	2.89	7.44	2.76	7.13	2.63	6.52	2.38
	-12.6	-13	8.18	2.81	8.18	2.87	8.18	2.93	7.85	2.81	7.53	2.68	6.88	2.42
	-10.5	-11	8.61	2.86	8.61	2.92	8.61	2.98	8.27	2.85	7.92	2.72	7.24	2.46

	-9.5	-10	8.81	2.88	8.81	2.94	8.81	3.01	8.46	2.87	8.11	2.74	7.41	2.48
	-8.5	-9.1	9.02	2.90	9.02	2.97	9.02	3.03	8.66	2.90	8.30	2.76	7.59	2.50
	-7	-7.6	9.33	2.94	9.33	3.00	9.33	3.06	8.96	2.93	8.59	2.79	7.85	2.53
	-5	-5.6	9.74	2.98	9.74	3.04	9.74	3.11	9.35	2.97	8.96	2.84	8.19	2.56
	-3	-3.7	10.15	3.02	10.15	3.09	10.15	3.15	9.74	3.01	9.34	2.88	8.54	2.60
	0	-0.7	10.76	3.09	10.76	3.16	10.76	3.22	10.34	3.08	9.91	2.94	9.05	2.66
	3	2.2	11.38	3.15	11.38	3.22	11.38	3.29	10.93	3.15	10.48	3.00	9.57	2.71
	5	4.1	11.79	3.20	11.79	3.27	11.79	3.33	11.32	3.19	10.85	3.04	9.92	2.75
	7	6	12.20	3.24	12.20	3.31	12.20	3.38	11.72	3.23	11.23	3.08	10.26	2.79
	9	7.9	12.20	3.13	12.20	3.20	12.20	3.27	11.72	3.12	11.23	2.98	10.26	2.69
	11	9.8	12.20	3.02	12.20	3.09	12.20	3.15	11.72	3.01	11.23	2.88	10.26	2.60
	13	11.8	12.20	2.92	12.20	2.98	12.20	3.04	11.72	2.91	11.23	2.77	10.26	2.51
	15	13.7	12.20	2.81	12.20	2.87	12.20	2.93	11.72	2.80	11.23	2.67	10.26	2.41
90%	-14.7	-15	6.97	2.46	6.97	2.51	6.97	2.56	6.69	2.45	6.42	2.34	5.86	2.11
	-12.6	-13	7.36	2.50	7.36	2.55	7.36	2.60	7.07	2.49	6.78	2.37	6.19	2.15
	-10.5	-11	7.75	2.54	7.75	2.59	7.75	2.64	7.44	2.53	7.13	2.41	6.52	2.18
	-9.5	-10	7.93	2.56	7.93	2.61	7.93	2.66	7.62	2.55	7.30	2.43	6.67	2.20
	-8.5	-9.1	8.12	2.57	8.12	2.63	8.12	2.68	7.79	2.57	7.47	2.45	6.83	2.21
	-7	-7.6	8.39	2.60	8.39	2.66	8.39	2.71	8.06	2.60	7.73	2.48	7.06	2.24
	-5	-5.6	8.76	2.64	8.76	2.70	8.76	2.76	8.42	2.63	8.07	2.51	7.37	2.27
	-3	-3.7	9.13	2.68	9.13	2.74	9.13	2.80	8.77	2.67	8.41	2.55	7.68	2.31
	0	-0.7	9.69	2.74	9.69	2.80	9.69	2.86	9.30	2.73	8.92	2.61	8.15	2.36
	3	2.2	10.24	2.80	10.24	2.86	10.24	2.92	9.83	2.79	9.43	2.66	8.62	2.41
	5	4.1	10.61	2.84	10.61	2.90	10.61	2.96	10.19	2.83	9.77	2.70	8.93	2.44
	7	6	10.98	2.87	10.98	2.94	10.98	3.00	10.54	2.87	10.11	2.73	9.24	2.47
	9	7.9	10.98	2.78	10.98	2.84	10.98	2.90	10.54	2.77	10.11	2.64	9.24	2.39
	11	9.8	10.98	2.68	10.98	2.74	10.98	2.80	10.54	2.67	10.11	2.55	9.24	2.31
	13	11.8	10.98	2.58	10.98	2.64	10.98	2.70	10.54	2.58	10.11	2.46	9.24	2.22
15	13.7	10.98	2.49	10.98	2.54	10.98	2.59	10.54	2.48	10.11	2.37	9.24	2.14	
80%	-14.7	-15	6.20	2.16	6.20	2.20	6.20	2.25	5.95	2.15	5.71	2.05	5.21	1.85
	-12.6	-13	6.54	2.19	6.54	2.24	6.54	2.28	6.28	2.18	6.02	2.08	5.50	1.88
	-10.5	-11	6.89	2.23	6.89	2.27	6.89	2.32	6.61	2.22	6.34	2.12	5.79	1.92
	-9.5	-10	7.05	2.24	7.05	2.29	7.05	2.34	6.77	2.24	6.49	2.13	5.93	1.93
	-8.5	-9.1	7.21	2.26	7.21	2.31	7.21	2.36	6.93	2.25	6.64	2.15	6.07	1.94
	-7	-7.6	7.46	2.29	7.46	2.34	7.46	2.38	7.17	2.28	6.87	2.18	6.28	1.97
	-5	-5.6	7.79	2.32	7.79	2.37	7.79	2.42	7.48	2.31	7.17	2.21	6.55	2.00
	-3	-3.7	8.12	2.35	8.12	2.40	8.12	2.45	7.80	2.35	7.47	2.24	6.83	2.02
	0	-0.7	8.61	2.41	8.61	2.46	8.61	2.51	8.27	2.40	7.93	2.29	7.24	2.07
	3	2.2	9.10	2.46	9.10	2.51	9.10	2.56	8.74	2.45	8.38	2.34	7.66	2.11
	5	4.1	9.43	2.49	9.43	2.54	9.43	2.60	9.06	2.48	8.68	2.37	7.93	2.14
	7	6	9.76	2.52	9.76	2.58	9.76	2.63	9.37	2.52	8.99	2.40	8.21	2.17
	9	7.9	9.76	2.44	9.76	2.49	9.76	2.54	9.37	2.43	8.99	2.32	8.21	2.10
	11	9.8	9.76	2.35	9.76	2.40	9.76	2.45	9.37	2.35	8.99	2.24	8.21	2.02
	13	11.8	9.76	2.27	9.76	2.32	9.76	2.37	9.37	2.26	8.99	2.16	8.21	1.95
15	13.7	9.76	2.18	9.76	2.23	9.76	2.28	9.37	2.18	8.99	2.08	8.21	1.88	
70%	-14.7	-15	5.42	1.86	5.42	1.90	5.42	1.94	5.21	1.85	4.99	1.77	4.56	1.60
	-12.6	-13	5.72	1.89	5.72	1.93	5.72	1.97	5.50	1.88	5.27	1.80	4.82	1.62
	-10.5	-11	6.03	1.92	6.03	1.96	6.03	2.00	5.79	1.91	5.55	1.82	5.07	1.65
	-9.5	-10	6.17	1.93	6.17	1.97	6.17	2.01	5.92	1.93	5.68	1.84	5.19	1.66
	-8.5	-9.1	6.31	1.95	6.31	1.99	6.31	2.03	6.06	1.94	5.81	1.85	5.31	1.67
	-7	-7.6	6.53	1.97	6.53	2.01	6.53	2.05	6.27	1.96	6.01	1.87	5.49	1.69
	-5	-5.6	6.82	2.00	6.82	2.04	6.82	2.08	6.55	1.99	6.27	1.90	5.73	1.72
	-3	-3.7	7.10	2.03	7.10	2.07	7.10	2.11	6.82	2.02	6.54	1.93	5.98	1.74
	0	-0.7	7.53	2.07	7.53	2.12	7.53	2.16	7.24	2.07	6.94	1.97	6.34	1.78
	3	2.2	7.97	2.12	7.97	2.16	7.97	2.21	7.65	2.11	7.33	2.01	6.70	1.82
	5	4.1	8.25	2.14	8.25	2.19	8.25	2.24	7.93	2.14	7.60	2.04	6.94	1.84
7	6	8.54	2.17	8.54	2.22	8.54	2.27	8.20	2.17	7.86	2.07	7.18	1.87	
9	7.9	8.54	2.10	8.54	2.15	8.54	2.19	8.20	2.09	7.86	2.00	7.18	1.81	

	11	9.8	8.54	2.03	8.54	2.07	8.54	2.11	8.20	2.02	7.86	1.93	7.18	1.74
	13	11.8	8.54	1.95	8.54	2.00	8.54	2.04	8.20	1.95	7.86	1.86	7.18	1.68
	15	13.7	8.54	1.88	8.54	1.92	8.54	1.96	8.20	1.88	7.86	1.79	7.18	1.62
60%	-14.7	-15	4.65	1.56	4.65	1.59	4.65	1.62	4.46	1.55	4.28	1.48	3.91	1.34
	-12.6	-13	4.91	1.58	4.91	1.62	4.91	1.65	4.71	1.58	4.52	1.51	4.13	1.36
	-10.5	-11	5.16	1.61	5.16	1.64	5.16	1.68	4.96	1.60	4.75	1.53	4.35	1.38
	-9.5	-10	5.29	1.62	5.29	1.66	5.29	1.69	5.08	1.62	4.87	1.54	4.45	1.39
	-8.5	-9.1	5.41	1.63	5.41	1.67	5.41	1.70	5.20	1.63	4.98	1.55	4.55	1.40
	-7	-7.6	5.60	1.65	5.60	1.69	5.60	1.72	5.37	1.65	5.15	1.57	4.71	1.42
	-5	-5.6	5.84	1.68	5.84	1.71	5.84	1.75	5.61	1.67	5.38	1.59	4.91	1.44
	-3	-3.7	6.09	1.70	6.09	1.74	6.09	1.77	5.85	1.70	5.61	1.62	5.12	1.46
	0	-0.7	6.46	1.74	6.46	1.77	6.46	1.81	6.20	1.73	5.95	1.65	5.43	1.49
	3	2.2	6.83	1.77	6.83	1.81	6.83	1.85	6.56	1.77	6.29	1.69	5.74	1.53
	5	4.1	7.07	1.80	7.07	1.84	7.07	1.88	6.79	1.79	6.51	1.71	5.95	1.55
	7	6	7.32	1.82	7.32	1.86	7.32	1.90	7.03	1.82	6.74	1.73	6.16	1.57
	9	7.9	7.32	1.76	7.32	1.80	7.32	1.84	7.03	1.76	6.74	1.68	6.16	1.52
	11	9.8	7.32	1.70	7.32	1.74	7.32	1.77	7.03	1.70	6.74	1.62	6.16	1.46
	13	11.8	7.32	1.64	7.32	1.67	7.32	1.71	7.03	1.63	6.74	1.56	6.16	1.41
15	13.7	7.32	1.58	7.32	1.61	7.32	1.65	7.03	1.57	6.74	1.50	6.16	1.36	
50%	-14.7	-15	3.87	1.26	3.87	1.28	3.87	1.31	3.72	1.25	3.57	1.20	3.26	1.08
	-12.6	-13	4.09	1.28	4.09	1.31	4.09	1.33	3.93	1.27	3.76	1.22	3.44	1.10
	-10.5	-11	4.30	1.30	4.30	1.33	4.30	1.35	4.13	1.30	3.96	1.24	3.62	1.12
	-9.5	-10	4.41	1.31	4.41	1.34	4.41	1.37	4.23	1.31	4.06	1.25	3.71	1.13
	-8.5	-9.1	4.51	1.32	4.51	1.35	4.51	1.38	4.33	1.32	4.15	1.26	3.79	1.13
	-7	-7.6	4.66	1.33	4.66	1.36	4.66	1.39	4.48	1.33	4.29	1.27	3.92	1.15
	-5	-5.6	4.87	1.35	4.87	1.38	4.87	1.41	4.68	1.35	4.48	1.29	4.10	1.16
	-3	-3.7	5.07	1.37	5.07	1.40	5.07	1.43	4.87	1.37	4.67	1.31	4.27	1.18
	0	-0.7	5.38	1.40	5.38	1.43	5.38	1.46	5.17	1.40	4.95	1.34	4.53	1.21
	3	2.2	5.69	1.43	5.69	1.46	5.69	1.49	5.46	1.43	5.24	1.36	4.79	1.23
	5	4.1	5.89	1.45	5.89	1.48	5.89	1.51	5.66	1.45	5.43	1.38	4.96	1.25
	7	6	6.10	1.47	6.10	1.50	6.10	1.54	5.86	1.47	5.62	1.40	5.13	1.27
	9	7.9	6.10	1.42	6.10	1.45	6.10	1.48	5.86	1.42	5.62	1.35	5.13	1.22
	11	9.8	6.10	1.37	6.10	1.40	6.10	1.43	5.86	1.37	5.62	1.31	5.13	1.18
	13	11.8	6.10	1.32	6.10	1.35	6.10	1.38	5.86	1.32	5.62	1.26	5.13	1.14
15	13.7	6.10	1.27	6.10	1.30	6.10	1.33	5.86	1.27	5.62	1.21	5.13	1.10	

MDV-V140W/N1

Cooling

Combination (%) (Capacity index)	Outdoor temperature(°C DB)	Indoor temperature(°C WB)													
		14.00		16.00		18.00		19.00		20.00		22.00		24.00	
		TC	PI	TC	PI	TC	PI	TC	PI	TC	PI	TC	PI	TC	PI
		kW	kW	kW	kW	kW	kW	kW	kW	kW	kW	kW	kW	kW	kW
130%	10.00	12.30	2.01	14.65	2.46	17.00	2.92	17.65	2.99	17.85	2.93	18.30	2.80	18.75	2.67
	12.00	12.30	2.04	14.65	2.50	17.00	2.98	17.40	2.97	17.65	2.91	18.05	2.78	18.50	2.74
	14.00	12.30	2.09	14.65	2.55	16.95	3.01	17.20	2.98	17.40	2.89	17.85	2.87	18.30	2.90
	16.00	12.30	2.12	14.65	2.60	16.75	3.00	16.95	2.96	17.15	2.99	17.60	3.02	18.05	3.05
	18.00	12.30	2.16	14.65	2.66	16.50	3.11	16.70	3.13	16.95	3.15	17.40	3.18	17.85	3.21
	19.00	12.30	2.21	14.65	2.83	16.25	3.27	16.50	3.28	16.70	3.30	17.15	3.33	17.60	3.37
	21.00	12.30	2.27	14.65	2.93	16.15	3.34	16.40	3.36	16.60	3.38	17.05	3.41	17.50	3.44
	23.00	12.30	2.43	14.65	3.14	15.95	3.50	16.15	3.51	16.35	3.53	16.80	3.57	17.25	3.60
	25.00	12.30	2.60	14.65	3.36	15.70	3.65	15.90	3.67	16.15	3.69	16.60	3.73	17.05	3.76
	27.00	12.30	2.77	14.65	3.60	15.50	3.80	15.70	3.83	15.90	3.84	16.35	3.88	16.80	3.93
	29.00	12.30	2.96	14.65	3.84	15.25	3.95	15.45	3.98	15.70	4.00	16.15	4.04	16.60	4.08
	31.00	12.30	3.16	14.60	4.07	15.00	4.11	15.25	4.14	15.45	4.15	15.90	4.20	16.35	4.25
	33.00	12.30	3.37	14.35	4.22	14.80	4.27	15.00	4.29	15.25	4.31	15.70	4.36	16.10	4.41
	35.00	12.30	3.59	14.10	4.37	14.55	4.42	14.80	4.45	15.00	4.47	15.45	4.53	15.90	4.57
	37.00	12.30	3.82	13.90	4.53	14.35	4.58	14.55	4.61	14.80	4.64	15.20	4.69	15.65	4.74
	39.00	12.30	4.07	13.65	4.58	14.10	4.74	14.35	4.77	14.55	4.80	15.00	4.85	15.45	4.91
41.00	12.30	4.28	13.51	4.62	13.95	4.78	14.20	4.81	14.40	4.84	14.85	4.86	14.86	4.95	
43.00	12.30	4.39	13.41	4.64	13.88	4.79	14.13	4.83	14.25	4.85	14.58	4.87	14.68	4.96	
120%	10.00	11.35	1.83	13.50	2.24	15.70	2.66	16.80	2.88	17.60	3.00	18.00	2.89	18.40	2.77
	12.00	11.35	1.87	13.50	2.28	15.70	2.71	16.80	2.93	17.35	2.98	17.75	2.87	18.15	2.76
	14.00	11.35	1.90	13.50	2.33	15.70	2.77	16.80	2.99	17.10	2.97	17.55	2.86	17.95	2.87
	16.00	11.35	1.94	13.50	2.37	15.70	2.82	16.70	3.01	16.90	2.97	17.30	3.00	17.70	3.03
	18.00	11.35	1.97	13.50	2.42	15.70	2.91	16.45	3.11	16.65	3.13	17.05	3.16	17.50	3.18
	19.00	11.35	2.02	13.50	2.51	15.70	3.14	16.25	3.27	16.45	3.28	16.85	3.31	17.25	3.34
	21.00	11.35	2.03	13.50	2.60	15.70	3.25	16.10	3.34	16.30	3.36	16.75	3.38	17.15	3.42
	23.00	11.35	2.17	13.50	2.79	15.70	3.48	15.90	3.49	16.10	3.51	16.50	3.54	16.90	3.57
	25.00	11.35	2.32	13.50	2.98	15.45	3.63	15.65	3.64	15.85	3.66	16.30	3.70	16.70	3.73
	27.00	11.35	2.48	13.50	3.19	15.25	3.78	15.45	3.80	15.65	3.82	16.05	3.85	16.45	3.89
	29.00	11.35	2.64	13.50	3.41	15.00	3.93	15.20	3.95	15.40	3.97	15.80	4.01	16.25	4.05
	31.00	11.35	2.82	13.50	3.64	14.75	4.09	15.00	4.11	15.20	4.13	15.60	4.17	16.00	4.21
	33.00	11.35	3.00	13.50	3.88	14.55	4.24	14.75	4.27	14.95	4.28	15.35	4.33	15.75	4.37
	35.00	11.35	3.20	13.50	4.14	14.30	4.39	14.50	4.42	14.75	4.44	15.15	4.49	15.55	4.54
	37.00	11.35	3.40	13.50	4.41	14.10	4.55	14.30	4.58	14.50	4.60	14.90	4.65	15.30	4.70
	39.00	11.35	3.62	13.45	4.65	13.85	4.71	14.05	4.74	14.25	4.76	14.70	4.81	15.10	4.86
41.00	11.35	3.72	13.34	4.69	13.74	4.74	13.94	4.77	14.14	4.79	14.59	4.83	14.67	4.90	
43.00	11.35	3.77	13.27	4.72	13.63	4.77	13.83	4.79	14.03	4.81	14.34	4.84	14.44	4.99	
110%	10.00	10.40	1.66	12.40	2.03	14.40	2.41	15.40	2.60	16.40	2.80	17.65	2.97	18.05	2.87
	12.00	10.40	1.70	12.40	2.07	14.40	2.46	15.40	2.66	16.40	2.86	17.45	2.96	17.80	2.86
	14.00	10.40	1.73	12.40	2.10	14.40	2.50	15.40	2.70	16.40	2.91	17.20	2.94	17.60	2.85
	16.00	10.40	1.76	12.40	2.14	14.40	2.55	15.40	2.76	16.40	2.97	17.00	2.98	17.35	3.01
	18.00	10.40	1.79	12.40	2.19	14.40	2.60	15.40	2.83	16.40	3.11	16.75	3.13	17.15	3.16
	19.00	10.40	1.83	12.40	2.23	14.40	2.76	15.40	3.04	16.15	3.26	16.55	3.28	16.90	3.31
	21.00	10.40	1.84	12.40	2.30	14.40	2.86	15.40	3.16	16.05	3.34	16.40	3.36	16.80	3.39
	23.00	10.40	1.93	12.40	2.46	14.40	3.06	15.40	3.38	15.80	3.48	16.20	3.52	16.55	3.55
	25.00	10.40	2.06	12.40	2.63	14.40	3.27	15.40	3.63	15.60	3.64	15.95	3.67	16.35	3.70
	27.00	10.40	2.20	12.40	2.81	14.40	3.50	15.15	3.78	15.35	3.79	15.75	3.83	16.10	3.86
	29.00	10.40	2.34	12.40	3.00	14.40	3.74	14.95	3.93	15.15	3.95	15.50	3.98	15.90	4.02
	31.00	10.40	2.50	12.40	3.20	14.40	4.00	14.70	4.08	14.90	4.10	15.30	4.14	15.65	4.18
	33.00	10.40	2.66	12.40	3.41	14.30	4.21	14.50	4.24	14.70	4.25	15.05	4.30	15.45	4.34
	35.00	10.40	2.83	12.40	3.64	14.05	4.37	14.25	4.39	14.45	4.41	14.80	4.45	15.20	4.50

	37.00	10.40	3.01	12.40	3.87	13.85	4.52	14.05	4.54	14.20	4.57	14.60	4.61	14.95	4.65
	39.00	10.40	3.20	12.40	4.13	13.60	4.68	13.80	4.70	14.00	4.72	14.35	4.77	14.75	4.82
	41.00	10.40	3.23	12.40	4.16	13.49	4.71	13.69	4.73	13.89	4.76	14.17	4.80	14.31	4.85
	43.00	10.40	3.26	12.40	4.21	13.39	4.74	13.59	4.77	13.79	4.79	14.04	4.82	14.09	4.95
100%	10.00	9.45	1.50	11.25	1.82	13.10	2.16	14.00	2.33	14.90	2.51	16.75	2.87	17.70	2.97
	12.00	9.45	1.53	11.25	1.86	13.10	2.20	14.00	2.37	14.90	2.56	16.75	2.92	17.45	2.95
	14.00	9.45	1.56	11.25	1.89	13.10	2.24	14.00	2.42	14.90	2.60	16.75	2.98	17.25	2.93
	16.00	9.45	1.59	11.25	1.93	13.10	2.29	14.00	2.47	14.90	2.66	16.65	3.01	17.00	2.98
	18.00	9.45	1.62	11.25	1.96	13.10	2.33	14.00	2.51	14.90	2.71	16.45	3.11	16.80	3.14
	19.00	9.45	1.65	11.25	2.00	13.10	2.40	14.00	2.64	14.90	2.90	16.20	3.26	16.55	3.29
	21.00	9.45	1.66	11.25	2.02	13.10	2.49	14.00	2.74	14.90	3.00	16.10	3.34	16.45	3.37
	23.00	9.45	1.70	11.25	2.16	13.10	2.66	14.00	2.93	14.90	3.22	15.90	3.49	16.20	3.52
	25.00	9.45	1.82	11.25	2.30	13.10	2.85	14.00	3.14	14.90	3.45	15.65	3.64	16.00	3.67
	27.00	9.45	1.94	11.25	2.46	13.10	3.04	14.00	3.36	14.90	3.69	15.40	3.80	15.75	3.83
	29.00	9.45	2.06	11.25	2.62	13.10	3.25	14.00	3.59	14.85	3.92	15.20	3.95	15.55	3.98
	31.00	9.45	2.20	11.25	2.80	13.10	3.47	14.00	3.83	14.65	4.07	14.95	4.11	15.30	4.14
	33.00	9.45	2.33	11.25	2.98	13.10	3.70	14.00	4.09	14.40	4.22	14.75	4.26	15.10	4.30
	35.00	9.45	2.48	11.25	3.17	13.10	3.94	14.00	4.36	14.15	4.38	14.50	4.42	14.85	4.45
	37.00	9.45	2.64	11.25	3.37	13.10	4.20	13.75	4.51	13.95	4.54	14.30	4.58	14.60	4.61
	39.00	9.45	2.80	11.25	3.58	13.10	4.47	13.55	4.67	13.70	4.69	14.05	4.73	14.40	4.78
41.00	9.45	2.93	11.25	3.72	13.10	4.64	13.34	4.70	13.59	4.76	13.81	4.84	14.19	4.88	
43.00	9.45	3.06	11.25	3.85	13.10	4.72	13.13	4.75	13.50	4.81	13.89	4.87	13.94	4.93	
90%	10.00	8.50	1.35	10.15	1.62	11.80	1.92	12.60	2.07	13.40	2.22	15.05	2.54	16.70	2.86
	12.00	8.50	1.37	10.15	1.65	11.80	1.95	12.60	2.10	13.40	2.26	15.05	2.59	16.70	2.91
	14.00	8.50	1.39	10.15	1.68	11.80	1.99	12.60	2.14	13.40	2.30	15.05	2.63	16.70	2.97
	16.00	8.50	1.42	10.15	1.71	11.80	2.03	12.60	2.19	13.40	2.35	15.05	2.69	16.65	3.02
	18.00	8.50	1.44	10.15	1.75	11.80	2.06	12.60	2.23	13.40	2.40	15.05	2.74	16.45	3.11
	19.00	8.50	1.47	10.15	1.79	11.80	2.10	12.60	2.27	13.40	2.49	15.05	2.94	16.20	3.26
	21.00	8.50	1.48	10.15	1.80	11.80	2.14	12.60	2.35	13.40	2.57	15.05	3.05	16.10	3.34
	23.00	8.50	1.51	10.15	1.87	11.80	2.29	12.60	2.52	13.40	2.76	15.05	3.27	15.85	3.49
	25.00	8.50	1.59	10.15	2.00	11.80	2.45	12.60	2.70	13.40	2.95	15.05	3.50	15.65	3.64
	27.00	8.50	1.69	10.15	2.13	11.80	2.61	12.60	2.88	13.40	3.16	15.05	3.75	15.40	3.80
	29.00	8.50	1.80	10.15	2.27	11.80	2.79	12.60	3.07	13.40	3.37	14.90	3.92	15.20	3.95
	31.00	8.50	1.92	10.15	2.42	11.80	2.97	12.60	3.28	13.40	3.60	14.65	4.07	14.95	4.11
	33.00	8.50	2.03	10.15	2.57	11.80	3.17	12.60	3.50	13.40	3.84	14.45	4.23	14.75	4.26
	35.00	8.50	2.16	10.15	2.73	11.80	3.38	12.60	3.73	13.40	4.09	14.20	4.38	14.50	4.42
	37.00	8.50	2.29	10.15	2.90	11.80	3.60	12.60	3.97	13.40	4.36	13.95	4.54	14.30	4.57
	39.00	8.50	2.43	10.15	3.09	11.80	3.83	12.60	4.22	13.40	4.64	13.75	4.69	14.05	4.73
41.00	8.50	2.52	10.15	3.23	11.80	3.96	12.60	4.34	13.40	4.67	13.65	4.81	13.96	4.84	
43.00	8.50	2.64	10.15	3.37	11.80	4.10	12.60	4.45	13.40	4.77	13.58	4.88	13.84	4.92	
80%	10.00	7.55	1.19	9.00	1.43	10.45	1.68	11.20	1.81	11.95	1.94	13.40	2.22	14.85	2.50
	12.00	7.55	1.21	9.00	1.45	10.45	1.71	11.20	1.85	11.95	1.98	13.40	2.26	14.85	2.54
	14.00	7.55	1.23	9.00	1.48	10.45	1.74	11.20	1.87	11.95	2.02	13.40	2.30	14.85	2.59
	16.00	7.55	1.25	9.00	1.50	10.45	1.77	11.20	1.91	11.95	2.05	13.40	2.34	14.85	2.64
	18.00	7.55	1.28	9.00	1.53	10.45	1.81	11.20	1.95	11.95	2.09	13.40	2.39	14.85	2.69
	19.00	7.55	1.30	9.00	1.56	10.45	1.85	11.20	1.99	11.95	2.13	13.40	2.48	14.85	2.88
	21.00	7.55	1.31	9.00	1.57	10.45	1.86	11.20	2.01	11.95	2.18	13.40	2.57	14.85	2.99
	23.00	7.55	1.33	9.00	1.61	10.45	1.95	11.20	2.14	11.95	2.33	13.40	2.75	14.85	3.20
	25.00	7.55	1.38	9.00	1.71	10.45	2.09	11.20	2.29	11.95	2.49	13.40	2.94	14.85	3.43
	27.00	7.55	1.46	9.00	1.82	10.45	2.22	11.20	2.44	11.95	2.66	13.40	3.14	14.85	3.67
	29.00	7.55	1.56	9.00	1.94	10.45	2.37	11.20	2.60	11.95	2.84	13.40	3.36	14.85	3.92
	31.00	7.55	1.65	9.00	2.06	10.45	2.52	11.20	2.77	11.95	3.03	13.40	3.58	14.60	4.07
	33.00	7.55	1.76	9.00	2.19	10.45	2.69	11.20	2.95	11.95	3.23	13.40	3.82	14.40	4.22
	35.00	7.55	1.86	9.00	2.33	10.45	2.86	11.20	3.14	11.95	3.44	13.40	4.07	14.15	4.38
	37.00	7.55	1.97	9.00	2.47	10.45	3.04	11.20	3.34	11.95	3.66	13.40	4.34	13.95	4.53
	39.00	7.55	2.09	9.00	2.64	10.45	3.23	11.20	3.56	11.95	3.90	13.40	4.62	13.70	4.69
41.00	7.55	2.14	9.00	2.66	10.45	3.28	11.20	3.65	11.95	3.97	13.40	4.74	13.62	4.77	
43.00	7.55	2.20	9.00	2.69	10.45	3.33	11.20	3.71	11.95	4.02	13.40	4.80	13.53	4.82	

70%	10.00	6.60	1.05	7.90	1.25	9.15	1.45	9.80	1.56	10.45	1.67	11.70	1.90	13.00	2.14
	12.00	6.60	1.06	7.90	1.26	9.15	1.48	9.80	1.59	10.45	1.70	11.70	1.94	13.00	2.18
	14.00	6.60	1.08	7.90	1.29	9.15	1.50	9.80	1.62	10.45	1.73	11.70	1.97	13.00	2.22
	16.00	6.60	1.10	7.90	1.31	9.15	1.53	9.80	1.65	10.45	1.77	11.70	2.01	13.00	2.26
	18.00	6.60	1.12	7.90	1.33	9.15	1.56	9.80	1.68	10.45	1.80	11.70	2.05	13.00	2.31
	19.00	6.60	1.13	7.90	1.36	9.15	1.59	9.80	1.71	10.45	1.83	11.70	2.09	13.00	2.37
	21.00	6.60	1.15	7.90	1.37	9.15	1.60	9.80	1.73	10.45	1.85	11.70	2.12	13.00	2.46
	23.00	6.60	1.16	7.90	1.39	9.15	1.64	9.80	1.79	10.45	1.95	11.70	2.27	13.00	2.63
	25.00	6.60	1.19	7.90	1.45	9.15	1.75	9.80	1.91	10.45	2.07	11.70	2.43	13.00	2.81
	27.00	6.60	1.26	7.90	1.55	9.15	1.86	9.80	2.03	10.45	2.22	11.70	2.60	13.00	3.01
	29.00	6.60	1.33	7.90	1.64	9.15	1.98	9.80	2.17	10.45	2.36	11.70	2.77	13.00	3.21
	31.00	6.60	1.41	7.90	1.74	9.15	2.11	9.80	2.30	10.45	2.51	11.70	2.95	13.00	3.43
	33.00	6.60	1.50	7.90	1.85	9.15	2.24	9.80	2.45	10.45	2.67	11.70	3.14	13.00	3.65
	35.00	6.60	1.59	7.90	1.96	9.15	2.38	9.80	2.61	10.45	2.84	11.70	3.35	13.00	3.90
	37.00	6.60	1.67	7.90	2.08	9.15	2.53	9.80	2.77	10.45	3.03	11.70	3.57	13.00	4.15
39.00	6.60	1.77	7.90	2.20	9.15	2.69	9.80	2.94	10.45	3.21	11.70	3.79	13.00	4.42	
41.00	6.60	1.85	7.90	2.28	9.15	2.76	9.80	3.04	10.45	3.31	11.70	3.95	13.00	4.61	
43.00	6.60	2.00	7.90	2.44	9.15	2.88	9.80	3.20	10.45	3.41	11.70	4.09	13.00	4.76	
60%	10.00	5.65	0.91	6.75	1.07	7.85	1.24	8.40	1.33	8.95	1.42	10.05	1.60	11.15	1.80
	12.00	5.65	0.93	6.75	1.09	7.85	1.26	8.40	1.35	8.95	1.44	10.05	1.63	11.15	1.83
	14.00	5.65	0.94	6.75	1.10	7.85	1.28	8.40	1.37	8.95	1.47	10.05	1.66	11.15	1.86
	16.00	5.65	0.95	6.75	1.12	7.85	1.30	8.40	1.40	8.95	1.49	10.05	1.69	11.15	1.90
	18.00	5.65	0.97	6.75	1.14	7.85	1.33	8.40	1.42	8.95	1.52	10.05	1.72	11.15	1.93
	19.00	5.65	0.98	6.75	1.16	7.85	1.35	8.40	1.45	8.95	1.55	10.05	1.76	11.15	1.97
	21.00	5.65	0.99	6.75	1.17	7.85	1.36	8.40	1.46	8.95	1.56	10.05	1.77	11.15	1.99
	23.00	5.65	1.00	6.75	1.19	7.85	1.39	8.40	1.49	8.95	1.59	10.05	1.84	11.15	2.12
	25.00	5.65	1.02	6.75	1.21	7.85	1.44	8.40	1.56	8.95	1.69	10.05	1.97	11.15	2.26
	27.00	5.65	1.06	6.75	1.29	7.85	1.53	8.40	1.67	8.95	1.80	10.05	2.10	11.15	2.41
	29.00	5.65	1.12	6.75	1.36	7.85	1.63	8.40	1.77	8.95	1.92	10.05	2.24	11.15	2.58
	31.00	5.65	1.19	6.75	1.45	7.85	1.73	8.40	1.89	8.95	2.04	10.05	2.38	11.15	2.74
	33.00	5.65	1.26	6.75	1.53	7.85	1.84	8.40	2.00	8.95	2.17	10.05	2.53	11.15	2.93
	35.00	5.65	1.33	6.75	1.63	7.85	1.95	8.40	2.13	8.95	2.31	10.05	2.70	11.15	3.11
	37.00	5.65	1.41	6.75	1.72	7.85	2.07	8.40	2.26	8.95	2.45	10.05	2.87	11.15	3.31
39.00	5.65	1.49	6.75	1.82	7.85	2.19	8.40	2.39	8.95	2.60	10.05	3.04	11.15	3.53	
41.00	5.65	1.53	6.75	1.90	7.85	2.27	8.40	2.49	8.95	2.70	10.05	3.19	11.15	3.68	
43.00	5.65	1.58	6.75	1.98	7.85	2.35	8.40	2.56	8.95	2.79	10.05	3.32	11.15	3.84	
50%	10.00	4.73	0.79	5.65	0.91	6.55	1.04	7.00	1.11	7.45	1.18	8.35	1.32	9.30	1.47
	12.00	4.73	0.79	5.65	0.92	6.55	1.06	7.00	1.12	7.45	1.20	8.35	1.35	9.30	1.50
	14.00	4.73	0.80	5.65	0.93	6.55	1.07	7.00	1.15	7.45	1.22	8.35	1.37	9.30	1.53
	16.00	4.73	0.82	5.65	0.95	6.55	1.09	7.00	1.16	7.45	1.23	8.35	1.39	9.30	1.55
	18.00	4.73	0.83	5.65	0.96	6.55	1.10	7.00	1.18	7.45	1.26	8.35	1.42	9.30	1.58
	19.00	4.73	0.84	5.65	0.98	6.55	1.12	7.00	1.20	7.45	1.28	8.35	1.44	9.30	1.61
	21.00	4.73	0.85	5.65	0.99	6.55	1.13	7.00	1.21	7.45	1.29	8.35	1.46	9.30	1.63
	23.00	4.73	0.86	5.65	1.00	6.55	1.15	7.00	1.23	7.45	1.32	8.35	1.48	9.30	1.66
	25.00	4.73	0.87	5.65	1.02	6.55	1.18	7.00	1.26	7.45	1.36	8.35	1.56	9.30	1.77
	27.00	4.73	0.89	5.65	1.06	6.55	1.24	7.00	1.34	7.45	1.44	8.35	1.66	9.30	1.89
	29.00	4.73	0.93	5.65	1.12	6.55	1.32	7.00	1.42	7.45	1.53	8.35	1.76	9.30	2.02
	31.00	4.73	0.99	5.65	1.18	6.55	1.39	7.00	1.51	7.45	1.63	8.35	1.87	9.30	2.14
	33.00	4.73	1.05	5.65	1.25	6.55	1.48	7.00	1.60	7.45	1.73	8.35	1.99	9.30	2.28
	35.00	4.73	1.10	5.65	1.32	6.55	1.56	7.00	1.69	7.45	1.83	8.35	2.12	9.30	2.42
	37.00	4.73	1.16	5.65	1.40	6.55	1.66	7.00	1.79	7.45	1.94	8.35	2.24	9.30	2.57
39.00	4.73	1.23	5.65	1.47	6.55	1.75	7.00	1.90	7.45	2.06	8.35	2.38	9.30	2.73	
41.00	4.73	1.28	5.65	1.54	6.55	1.81	7.00	1.99	7.45	2.15	8.35	2.51	9.30	2.86	
43.00	4.73	1.36	5.65	1.64	6.55	1.88	7.00	2.08	7.45	2.20	8.35	2.63	9.30	2.99	



Heating

Combination (Capacity index)	Outdoor air temp.		Indoor temperature(°C DB)											
			16		18		20		21		22		24	
	°C DB	°C WB	TC	PI	TC	PI	TC	PI	TC	PI	TC	PI	TC	PI
130%	-14.7	-15	10.67	3.27	10.62	3.45	10.57	3.64	10.57	3.73	10.52	3.83	10.52	4.02
	-12.6	-13	11.10	3.41	11.10	3.59	11.05	3.77	11.00	3.86	11.00	3.95	10.95	4.13
	-10.5	-11	11.62	3.56	11.57	3.73	11.52	3.90	11.52	3.99	11.52	4.08	11.48	4.25
	-9.5	-10	11.90	3.64	11.86	3.80	11.81	3.97	11.81	4.05	11.76	4.14	11.76	4.30
	-8.5	-9.1	12.14	3.70	12.10	3.86	12.10	4.03	12.05	4.11	12.05	4.19	12.00	4.36
	-7	-7.6	12.57	3.81	12.57	3.97	12.52	4.12	12.52	4.21	12.48	4.28	12.43	4.44
	-5	-5.6	13.24	3.95	13.19	4.10	13.14	4.25	13.14	4.33	13.10	4.40	13.10	4.55
	-3	-3.7	13.86	4.08	13.81	4.23	13.81	4.37	13.76	4.44	13.76	4.51	13.71	4.65
	0	-0.7	14.95	4.28	14.95	4.41	14.90	4.54	14.90	4.59	14.86	4.68	14.86	4.81
	3	2.2	16.14	4.46	16.10	4.58	16.05	4.70	16.05	4.76	16.05	4.83	16.00	4.95
	5	4.1	16.95	4.57	16.90	4.69	16.90	4.80	16.86	4.86	16.86	4.92	16.81	5.03
	7	6	17.81	4.68	17.76	4.78	17.76	4.90	17.71	4.95	17.71	5.00	17.00	4.81
	9	7.9	18.71	4.77	18.67	4.88	18.67	4.98	18.62	5.04	18.24	4.93	17.00	4.52
	11	9.8	19.67	4.87	19.62	4.97	19.52	5.03	18.86	4.83	18.24	4.63	17.00	4.25
	13	11.8	20.71	4.96	20.67	5.06	19.52	4.71	18.86	4.53	18.24	4.35	17.00	3.99
15	13.7	21.71	5.05	20.76	4.79	19.52	4.44	18.86	4.27	18.24	4.10	17.00	3.77	
120%	-14.7	-15	10.62	3.52	10.57	3.69	10.52	3.86	10.52	3.95	10.52	4.04	10.48	4.21
	-12.6	-13	11.05	3.65	11.05	3.82	11.00	3.99	11.00	4.07	10.95	4.15	10.95	4.32
	-10.5	-11	11.57	3.79	11.52	3.95	11.52	4.11	11.48	4.19	11.48	4.26	11.43	4.43
	-9.5	-10	11.86	3.86	11.81	4.02	11.76	4.17	11.76	4.25	11.76	4.32	11.71	4.48
	-8.5	-9.1	12.10	3.92	12.05	4.07	12.05	4.22	12.00	4.30	12.00	4.38	11.95	4.53
	-7	-7.6	12.52	4.02	12.52	4.17	12.48	4.31	12.48	4.39	12.43	4.46	12.43	4.60
	-5	-5.6	13.19	4.15	13.14	4.29	13.09	4.43	13.09	4.50	13.09	4.57	13.05	4.70
	-3	-3.7	13.81	4.27	13.81	4.41	13.76	4.54	13.76	4.60	13.71	4.67	13.71	4.80
	0	-0.7	14.91	4.46	14.91	4.58	14.86	4.70	14.86	4.76	14.81	4.82	14.81	4.95
	3	2.2	16.10	4.62	16.05	4.74	16.05	4.85	16.00	4.91	16.00	4.96	15.67	4.93
	5	4.1	16.91	4.73	16.86	4.83	16.86	4.94	16.81	4.99	16.81	5.05	15.67	4.63
	7	6	17.76	4.82	17.76	4.92	17.72	5.03	17.43	4.96	16.86	4.75	15.67	4.36
	9	7.9	18.67	4.92	18.62	5.02	18.00	4.85	17.43	4.66	16.86	4.47	15.67	4.10
	11	9.8	19.62	5.00	19.14	4.92	18.00	4.56	17.43	4.38	16.86	4.21	15.67	3.87
	13	11.8	20.33	4.96	19.14	4.61	18.00	4.27	17.43	4.11	16.86	3.95	15.67	3.64
15	13.7	20.33	4.67	19.14	4.34	18.00	4.03	17.43	3.88	16.86	3.73	15.67	3.43	
110%	-14.7	-15	10.57	3.77	10.53	3.93	10.48	4.09	10.48	4.17	10.48	4.25	10.43	4.40
	-12.6	-13	11.00	3.90	11.00	4.05	10.95	4.20	10.95	4.28	10.90	4.35	10.90	4.51
	-10.5	-11	11.52	4.02	11.48	4.17	11.48	4.31	11.43	4.39	11.43	4.46	11.43	4.60
	-9.5	-10	11.81	4.09	11.76	4.23	11.71	4.37	11.71	4.44	11.71	4.51	11.67	4.65
	-8.5	-9.1	12.05	4.14	12.00	4.28	12.00	4.42	11.95	4.49	11.95	4.56	11.95	4.16
	-7	-7.6	12.48	4.24	12.48	4.37	12.43	4.50	12.43	4.57	12.43	4.63	12.38	4.77
	-5	-5.6	13.14	4.36	13.10	4.48	13.05	4.61	13.05	4.67	13.05	4.74	13.00	4.87
	-3	-3.7	13.76	4.47	13.76	4.59	13.71	4.71	13.71	4.77	13.67	4.83	13.67	4.95
	0	-0.7	14.86	4.63	14.86	4.75	14.81	4.86	14.81	4.91	14.81	4.97	14.38	4.88
	3	2.2	16.05	4.79	16.00	4.89	16.00	4.99	15.95	5.04	15.43	4.84	14.38	4.44
	5	4.1	16.86	4.88	16.86	4.98	16.52	4.93	15.95	4.74	15.43	4.55	14.38	4.17
	7	6	17.71	4.97	17.57	5.00	16.52	4.63	15.95	4.45	15.43	4.28	14.38	3.93
	9	7.9	18.62	5.05	17.57	4.70	16.52	4.36	15.95	4.19	15.43	4.02	14.38	3.70
	11	9.8	18.62	4.75	17.57	4.43	16.52	4.10	15.95	3.95	15.43	3.79	14.38	3.49
	13	11.8	18.62	4.46	17.57	4.15	16.52	3.86	15.95	3.71	15.43	3.57	14.38	3.29
15	13.7	18.62	3.96	17.57	3.92	16.52	3.64	15.95	3.50	15.43	3.37	14.38	3.11	
100%	-14.7	-15	10.52	4.02	10.48	4.17	10.43	4.31	10.43	4.39	10.43	4.46	10.38	4.60
	-12.6	-13	10.95	4.14	10.95	4.27	10.91	4.41	10.91	4.48	10.91	4.55	10.86	4.69
	-10.5	-11	11.48	4.25	11.43	4.39	11.43	4.52	11.43	4.59	11.38	4.65	11.38	4.78
	-9.5	-10	11.76	4.31	11.72	4.44	11.72	4.57	11.67	4.63	11.67	4.70	11.62	4.83
	-8.5	-9.1	12.00	4.36	11.95	4.49	11.95	4.61	11.95	4.68	11.91	4.74	11.91	4.86
	-7	-7.6	12.43	4.45	12.43	4.57	12.38	4.69	12.38	4.75	12.38	4.81	12.33	4.93

	-5	-5.6	13.10	4.56	13.05	4.67	13.05	4.79	13.00	4.84	13.00	4.90	12.95	5.02
	-3	-3.7	13.71	4.66	13.71	4.23	13.67	4.88	13.67	4.93	13.67	4.99	13.10	4.78
	0	-0.7	14.81	4.81	14.81	4.91	14.76	5.02	14.52	4.93	14.05	4.73	13.10	4.34
	3	2.2	16.00	4.95	15.95	5.04	15.00	4.67	14.52	4.48	14.05	4.31	13.10	3.95
	5	4.1	16.81	5.04	15.95	4.74	15.00	4.39	14.52	4.22	14.05	4.05	13.10	3.73
	7	6	16.91	4.78	15.95	4.45	15.00	4.13	14.52	3.97	14.05	3.82	13.10	3.51
	9	7.9	16.91	4.49	15.95	4.19	15.00	3.89	14.52	3.70	14.05	3.60	13.10	3.31
	11	9.8	16.91	4.23	15.95	3.95	15.00	3.67	14.52	3.53	14.05	3.40	13.10	3.13
	13	11.8	16.91	3.97	15.95	3.71	15.00	3.45	14.52	3.33	14.05	3.20	13.10	2.96
	15	13.7	16.91	3.75	15.95	3.50	15.00	3.26	14.52	3.14	14.05	3.03	13.10	2.80
90%	-14.7	-15	10.46	4.28	10.41	4.41	10.41	4.54	10.36	4.60	10.36	4.67	10.36	4.79
	-12.6	-13	10.89	4.38	10.89	4.51	10.84	4.63	10.84	4.69	10.84	4.75	10.79	4.88
	-10.5	-11	11.41	4.48	11.41	4.60	11.36	4.72	11.36	4.78	11.36	4.84	11.31	4.96
	-9.5	-10	11.69	4.54	11.65	4.66	11.65	4.77	11.60	4.83	11.60	4.89	11.60	5.00
	-8.5	-9.1	11.93	4.59	11.93	4.70	11.88	4.81	11.88	4.86	11.88	4.92	11.74	4.97
	-7	-7.6	12.36	4.66	12.36	4.77	12.31	4.88	12.31	4.93	12.31	4.99	11.74	4.75
	-5	-5.6	13.02	4.76	12.98	4.86	12.98	4.97	12.93	5.02	12.60	4.86	11.74	4.46
	-3	-3.7	13.64	4.85	13.64	4.95	13.50	4.97	13.02	4.77	12.60	4.58	11.74	4.20
	0	-0.7	14.78	4.99	14.36	4.87	13.50	4.51	13.02	4.33	12.60	4.16	11.74	3.82
	3	2.2	15.21	4.76	14.36	4.43	13.50	4.11	13.02	3.95	12.60	3.80	11.74	3.50
	5	4.1	15.21	4.47	14.36	4.17	13.50	3.87	13.02	3.72	12.60	3.58	11.74	3.30
	7	6	15.21	4.20	14.36	3.93	13.50	3.65	13.02	3.51	12.60	3.38	11.74	3.12
	9	7.9	15.21	3.96	14.36	3.70	13.50	3.44	13.02	3.31	12.60	3.19	11.74	2.94
	11	9.8	15.21	3.73	14.36	3.49	13.50	3.25	13.02	3.13	12.60	3.01	11.74	2.79
	13	11.8	15.21	3.51	14.36	3.29	13.50	3.06	13.02	2.96	12.60	2.85	11.74	2.63
15	13.7	15.21	3.32	14.36	3.11	13.50	2.90	13.02	2.80	12.60	2.70	11.74	2.50	
80%	-14.7	-15	10.43	4.53	10.38	4.64	10.38	4.76	10.38	4.82	10.33	4.88	10.33	4.99
	-12.6	-13	10.86	4.62	10.86	4.74	10.81	4.84	10.81	4.90	10.81	4.96	10.48	4.82
	-10.5	-11	11.38	4.71	11.38	4.82	11.33	4.93	11.33	4.98	11.24	4.97	10.48	4.55
	-9.5	-10	11.67	4.76	11.62	4.86	11.62	4.97	11.62	5.02	11.24	4.82	10.48	4.42
	-8.5	-9.1	11.91	4.81	11.07	4.91	11.86	5.00	11.62	4.89	11.24	4.69	10.48	4.30
	-7	-7.6	12.33	4.88	12.33	4.97	12.00	4.86	11.62	4.67	11.24	4.48	10.48	4.11
	-5	-5.6	13.00	4.96	12.76	4.93	12.00	4.57	11.62	4.39	11.24	4.22	10.48	3.87
	-3	-3.7	13.52	4.99	12.76	4.64	12.00	4.30	11.62	4.14	11.24	3.97	10.48	3.66
	0	-0.7	13.52	4.53	12.76	4.22	12.00	3.92	11.62	3.77	11.24	3.62	10.48	3.34
	3	2.2	13.52	4.12	12.76	3.85	12.00	3.58	11.62	3.44	11.24	3.31	10.48	3.06
	5	4.1	13.52	3.88	12.76	3.63	12.00	3.37	11.62	3.25	11.24	3.13	10.48	2.89
	7	6	13.52	3.66	12.76	3.42	12.00	3.19	11.62	3.07	11.24	2.96	10.48	2.74
	9	7.9	13.52	3.45	12.76	3.23	12.00	3.01	11.62	2.90	11.24	2.80	10.48	2.59
	11	9.8	13.52	3.26	12.76	3.05	12.00	2.85	11.62	2.75	11.24	2.65	10.48	2.46
	13	11.8	13.52	3.07	12.76	2.88	12.00	2.69	11.62	2.60	11.24	2.50	10.48	2.32
15	13.7	13.52	2.91	12.76	2.73	12.00	2.55	11.62	2.46	11.24	2.38	10.48	2.21	
70%	-14.7	-15	10.36	4.78	10.31	4.89	10.31	4.99	10.12	4.91	9.79	4.71	9.12	4.32
	-12.6	-13	10.78	4.86	10.78	4.96	10.50	4.84	10.12	4.66	9.79	4.47	9.12	4.10
	-10.5	-11	11.31	4.95	11.16	4.94	10.50	4.57	10.12	4.40	9.79	4.22	9.12	3.88
	-9.5	-10	11.59	4.99	11.16	4.79	10.50	4.44	10.12	4.27	9.79	4.10	9.12	3.77
	-8.5	-9.1	11.83	5.01	11.16	4.67	10.50	4.32	10.12	4.16	9.79	4.00	9.12	3.67
	-7	-7.6	11.83	4.79	11.16	4.46	10.50	4.14	10.12	3.98	9.79	3.82	9.12	3.52
	-5	-5.6	11.83	4.50	11.16	4.19	10.50	3.89	10.12	3.74	9.79	4.42	9.12	3.32
	-3	-3.7	11.83	4.24	11.16	3.95	10.50	3.67	10.12	3.53	9.79	3.40	9.12	3.14
	0	-0.7	11.83	3.86	11.16	3.60	10.50	3.35	10.12	3.23	9.79	3.11	9.12	2.87
	3	2.2	11.83	3.52	11.16	3.30	10.50	3.07	10.12	2.96	9.79	2.85	9.12	2.64
	5	4.1	11.83	3.33	11.16	3.11	10.50	2.91	10.12	2.80	9.79	2.70	9.12	2.50
	7	6	11.83	3.14	11.16	2.94	10.50	2.75	10.12	2.65	9.79	2.56	9.12	2.37
	9	7.9	11.83	2.97	11.16	2.78	10.50	2.60	10.12	2.51	9.79	2.42	9.12	2.25
	11	9.8	11.83	2.81	11.16	2.63	10.50	2.47	10.12	2.38	9.79	2.30	9.12	2.13
	13	11.8	11.83	2.65	11.16	2.49	10.50	2.33	10.12	2.26	9.79	2.18	9.12	2.03
15	13.7	11.83	2.52	11.16	2.37	10.50	2.21	10.12	2.15	9.79	2.07	9.12	1.93	
60%	-14.7	-15	10.14	4.91	9.57	4.57	9.00	4.24	8.71	4.08	8.43	3.92	7.86	3.60
	-12.6	-13	10.14	4.65	9.57	4.33	9.00	4.02	8.71	3.87	8.43	3.72	7.86	3.44
	-10.5	-11	10.14	4.39	9.57	4.09	9.00	3.80	8.71	3.66	8.43	3.52	7.86	3.24
	-9.5	-10	10.14	4.27	9.57	3.98	9.00	3.70	8.71	3.56	8.43	3.42	7.86	3.15
	-8.5	-9.1	10.14	4.16	9.57	3.88	9.00	3.60	8.71	3.47	8.43	3.34	7.86	3.08

Capacity Tables

MHVAC-HTSM- 2011-07

	-7	-7.6	10.14	3.97	9.57	3.71	9.00	3.45	8.71	3.33	8.43	3.20	7.86	2.96
	-5	-5.6	10.14	3.74	9.57	3.50	9.00	3.26	8.71	3.14	8.43	3.02	7.86	2.79
	-3	-3.7	10.14	3.53	9.57	3.30	9.00	3.08	8.71	2.97	8.43	2.86	7.86	2.64
	0	-0.7	10.14	3.23	9.57	3.02	9.00	2.82	8.71	2.72	8.43	2.62	7.86	2.43
	3	2.2	10.14	2.96	9.57	2.78	9.00	2.60	8.71	2.50	8.43	2.42	7.86	2.24
	5	4.1	10.14	2.80	9.57	2.63	9.00	2.46	8.71	2.38	8.43	2.29	7.86	2.13
	7	6	10.14	2.65	9.57	2.49	9.00	2.33	8.71	2.25	8.43	2.18	7.86	2.02
	9	7.9	10.14	2.51	9.57	2.36	9.00	2.21	8.71	2.14	8.43	2.06	7.86	1.93
	11	9.8	10.14	2.38	9.57	2.24	9.00	2.10	8.71	2.03	8.43	1.96	7.86	1.83
	13	11.8	10.14	2.25	9.57	2.12	9.00	2.00	8.71	1.93	8.43	1.87	7.86	1.74
	15	13.7	10.14	2.15	9.57	2.02	9.00	1.90	8.71	1.84	8.43	1.78	7.86	1.66
50%	-14.7	-15	8.45	3.94	7.97	3.67	7.50	3.42	7.22	3.29	6.98	3.17	6.50	2.93
	-12.6	-13	8.45	3.74	7.97	3.49	7.50	3.25	7.22	3.13	6.98	3.01	6.50	2.79
	-10.5	-11	8.45	3.54	7.97	3.31	7.50	3.08	7.22	2.97	6.98	2.86	6.50	2.65
	-9.5	-10	8.45	3.44	7.97	3.22	7.50	3.00	7.22	2.90	6.98	2.79	6.50	2.58
	-8.5	-9.1	8.45	3.36	7.97	3.14	7.50	2.93	7.22	2.83	6.98	2.72	6.50	2.52
	-7	-7.6	8.45	3.22	7.97	3.01	7.50	2.81	7.22	2.71	6.98	2.62	6.50	2.42
	-5	-5.6	8.45	3.04	7.97	2.85	7.50	2.66	7.22	2.57	6.98	2.48	6.50	2.30
	-3	-3.7	8.45	2.87	7.97	2.70	7.50	2.52	7.22	2.43	6.98	2.35	6.50	2.18
	0	-0.7	8.45	2.64	7.97	2.48	7.50	2.32	7.22	2.24	6.98	2.17	6.50	2.02
	3	2.2	8.45	2.43	7.97	2.28	7.50	2.14	7.22	2.07	6.98	2.00	6.50	1.87
	5	4.1	8.45	2.31	7.97	2.17	7.50	2.03	7.22	1.97	6.98	1.90	6.50	1.78
	7	6	8.45	2.19	7.97	2.06	7.50	1.94	7.22	1.87	6.98	1.81	6.50	1.69
	9	7.9	8.45	2.08	7.97	1.96	7.50	1.84	7.22	1.79	6.98	1.73	6.50	1.61
	11	9.8	8.45	1.97	7.97	1.86	7.50	1.75	7.22	1.70	6.98	1.65	6.50	1.54
	13	11.8	8.45	1.88	7.97	1.77	7.50	1.67	7.22	1.62	6.98	1.57	6.50	1.47
15	13.7	8.45	1.79	7.97	1.69	7.50	1.59	7.22	1.54	6.98	1.50	6.50	1.41	

MDV-V105W/BDRN1

Cooling

Combination (Capacity index)	Outdoor temperature (°C DB)	Indoor temperature(°C WB)													
		14.00		16.00		18.00		19.00		20.00		22.00		24.00	
		TC	PI	TC	PI	TC	PI	TC	PI	TC	PI	TC	PI	TC	PI
		kW	kW	kW	kW	kW	kW	kW	kW	kW	kW	kW	kW	kW	kW
130%	10.00	7.97	1.23	9.41	1.54	10.85	1.84	11.51	1.99	12.17	2.15	12.44	2.16	12.70	2.18
	12.00	7.97	1.26	9.41	1.56	10.85	1.87	11.51	2.03	12.17	2.19	12.44	2.20	12.70	2.22
	14.00	7.97	1.28	9.41	1.59	10.85	1.91	11.51	2.07	12.17	2.23	12.44	2.24	12.70	2.26
	16.00	7.97	1.30	9.41	1.62	10.85	1.94	11.51	2.10	12.17	2.27	12.44	2.28	12.70	2.30
	18.00	7.97	1.32	9.41	1.65	10.85	1.97	11.51	2.14	12.17	2.31	12.44	2.32	12.70	2.34
	19.00	7.97	1.35	9.41	1.68	10.85	2.01	11.51	2.18	12.17	2.35	12.44	2.36	12.70	2.38
	21.00	7.97	1.44	9.41	1.80	10.85	2.15	11.51	2.34	12.17	2.52	12.44	2.53	12.70	2.55
	23.00	7.97	1.55	9.41	1.93	10.85	2.31	11.51	2.50	12.17	2.70	12.44	2.70	12.70	2.73
	25.00	7.97	1.16	9.41	2.06	10.85	2.47	11.51	2.68	12.17	2.89	12.44	2.89	12.70	2.92
	27.00	7.97	1.77	9.41	2.20	10.85	2.64	11.51	2.86	12.17	3.08	12.44	3.09	12.70	3.12
	29.00	7.97	1.89	9.41	2.35	10.85	2.82	11.51	3.06	12.17	3.29	12.44	3.30	12.70	3.34
	31.00	7.97	2.01	9.41	2.51	10.85	3.00	11.51	3.26	12.17	3.51	12.44	3.52	12.70	3.56
	33.00	7.97	2.14	9.41	2.67	10.85	3.20	11.51	3.47	12.17	3.74	12.44	3.75	12.70	3.79
	35.00	7.97	2.28	9.41	2.84	10.85	3.40	11.51	3.69	12.17	3.98	12.44	3.99	12.70	4.03
	37.00	7.97	2.43	9.41	3.02	10.85	3.62	11.51	3.93	12.17	4.23	12.44	4.25	12.70	4.29
39.00	7.97	2.44	9.41	3.04	10.85	3.64	11.51	3.94	12.17	4.25	12.44	4.26	12.70	4.31	
41.00	7.97	2.45	9.41	3.05	10.85	3.65	11.51	3.96	12.17	4.27	12.44	4.28	12.70	4.33	
43.00	7.97	2.46	9.41	3.06	10.85	3.67	11.51	3.98	12.17	4.29	12.44	4.30	12.70	4.35	
120%	10.00	7.84	1.22	9.26	1.52	10.67	1.82	11.32	1.97	11.98	2.13	12.24	2.14	12.50	2.16
	12.00	7.84	1.24	9.26	1.55	10.67	1.85	11.32	2.01	11.98	2.17	12.24	2.17	12.50	2.20
	14.00	7.84	1.27	9.26	1.58	10.67	1.89	11.32	2.05	11.98	2.21	12.24	2.21	12.50	2.24
	16.00	7.84	1.29	9.26	1.60	10.67	1.92	11.32	2.08	11.98	2.25	12.24	2.25	12.50	2.28
	18.00	7.84	1.31	9.26	1.63	10.67	1.96	11.32	2.12	11.98	2.29	12.24	2.29	12.50	2.32
	19.00	7.84	1.33	9.26	1.66	10.67	1.99	11.32	2.16	11.98	2.33	12.24	2.33	12.50	2.36
	21.00	7.84	1.43	9.26	1.78	10.67	2.13	11.32	2.31	11.98	2.49	12.24	2.50	12.50	2.53
	23.00	7.84	1.53	9.26	1.91	10.67	2.28	11.32	2.48	11.98	2.67	12.24	2.68	12.50	2.70
	25.00	7.84	1.64	9.26	2.04	10.67	2.44	11.32	2.65	11.98	2.86	12.24	2.87	12.50	2.89
	27.00	7.84	1.75	9.26	2.18	10.67	2.61	11.32	2.83	11.98	3.06	12.24	3.06	12.50	3.09
	29.00	7.84	1.87	9.26	2.33	10.67	2.79	11.32	3.03	11.98	3.26	12.24	3.27	12.50	3.30
	31.00	7.84	1.99	9.26	2.48	10.67	2.98	11.32	3.23	11.98	3.48	12.24	3.49	12.50	3.52
	33.00	7.84	2.12	9.26	2.65	10.67	3.17	11.32	3.44	11.98	3.71	12.24	3.72	12.50	3.75
	35.00	7.84	2.26	9.26	2.82	10.67	3.37	11.32	3.66	11.98	3.94	12.24	3.95	12.50	3.99
	37.00	7.84	2.40	9.26	2.99	10.67	3.59	11.32	3.89	11.98	4.19	12.24	4.21	12.50	4.25
39.00	7.84	2.41	9.26	3.01	10.67	3.60	11.32	3.91	11.98	4.21	12.24	4.22	12.50	4.26	
41.00	7.84	2.42	9.26	3.02	10.67	3.62	11.32	3.92	11.98	4.23	12.24	4.24	12.50	4.28	
43.00	7.84	2.44	9.26	3.04	10.67	3.63	11.32	3.94	11.98	4.25	12.24	4.26	12.50	4.30	
110%	10.00	7.71	0.62	9.11	0.77	10.50	0.92	11.14	1.00	11.78	1.08	12.04	1.08	12.29	1.09
	12.00	7.71	0.63	9.11	0.78	10.50	0.94	11.14	1.02	11.78	1.10	12.04	1.10	12.29	1.11
	14.00	7.71	0.64	9.11	0.80	10.50	0.95	11.14	1.04	11.78	1.12	12.04	1.12	12.29	1.13
	16.00	7.71	0.65	9.11	0.81	10.50	0.97	11.14	1.05	11.78	1.14	12.04	1.14	12.29	1.15
	18.00	7.71	0.66	9.11	0.83	10.50	0.99	11.14	1.07	11.78	1.16	12.04	1.16	12.29	1.17
	19.00	7.71	0.67	9.11	0.84	10.50	1.01	11.14	1.09	11.78	1.18	12.04	1.18	12.29	1.19
	21.00	7.71	0.72	9.11	0.90	10.50	1.08	11.14	1.17	11.78	1.26	12.04	1.26	12.29	1.28
	23.00	7.71	0.77	9.11	0.96	10.50	1.15	11.14	1.25	11.78	1.35	12.04	1.35	12.29	1.37
	25.00	7.71	0.83	9.11	1.03	10.50	1.24	11.14	1.34	11.78	1.44	12.04	1.45	12.29	1.46
	27.00	7.71	0.89	9.11	1.10	10.50	1.32	11.14	1.43	11.78	1.54	12.04	1.55	12.29	1.56
	29.00	7.71	0.95	9.11	1.18	10.50	1.41	11.14	1.53	11.78	1.65	12.04	1.65	12.29	1.67
	31.00	7.71	1.01	9.11	1.26	10.50	1.50	11.14	1.63	11.78	1.76	12.04	1.76	12.29	1.78
	33.00	7.71	1.07	9.11	1.34	10.50	1.60	11.14	1.74	11.78	1.87	12.04	1.88	12.29	1.90
35.00	7.71	1.14	9.11	1.42	10.50	1.70	11.14	1.85	11.78	1.99	12.04	2.00	12.29	2.02	

	37.00	7.71	1.22	9.11	1.51	10.50	1.81	11.14	1.97	11.78	2.12	12.04	2.13	12.29	2.15
	39.00	7.71	1.22	9.11	1.52	10.50	1.82	11.14	1.97	11.78	2.13	12.04	2.14	12.29	2.16
	41.00	7.71	1.23	9.11	1.53	10.50	1.83	11.14	1.98	11.78	2.14	12.04	2.15	12.29	2.17
	43.00	7.71	1.23	9.11	1.53	10.50	1.84	11.14	1.99	11.78	2.15	12.04	2.16	12.29	2.18
100%	10.00	7.27	1.13	8.58	1.41	9.90	1.68	10.50	1.83	11.10	1.97	11.35	1.97	11.59	1.99
	12.00	7.27	1.15	8.58	1.43	9.90	1.71	10.50	1.86	11.10	2.00	11.35	2.01	11.59	2.03
	14.00	7.27	1.17	8.58	1.46	9.90	1.75	10.50	1.89	11.10	2.04	11.35	2.05	11.59	2.07
	16.00	7.27	1.19	8.58	1.48	9.90	1.78	10.50	1.93	11.10	2.08	11.35	2.08	11.59	2.10
	18.00	7.27	1.21	8.58	1.51	9.90	1.81	10.50	1.96	11.10	2.11	11.35	2.12	11.59	2.14
	19.00	7.27	1.23	8.58	1.54	9.90	1.84	10.50	1.99	11.10	2.15	11.35	2.16	11.59	2.18
	21.00	7.27	1.32	8.58	1.65	9.90	1.97	10.50	2.14	11.10	2.30	11.35	2.31	11.59	2.33
	23.00	7.27	1.42	8.58	1.76	9.90	2.11	10.50	2.29	11.10	2.47	11.35	2.48	11.59	2.50
	25.00	7.27	1.51	8.58	1.89	9.90	2.26	10.50	2.45	11.10	2.64	11.35	2.65	11.59	2.68
	27.00	7.27	1.62	8.58	2.02	9.90	2.42	10.50	2.62	11.10	2.82	11.35	2.83	11.59	2.86
	29.00	7.27	1.73	8.58	2.15	9.90	2.58	10.50	2.80	11.10	3.02	11.35	3.02	11.59	3.05
	31.00	7.27	1.84	8.58	2.30	9.90	2.75	10.50	2.98	11.10	3.22	11.35	3.23	11.59	3.26
	33.00	7.27	1.96	8.58	2.45	9.90	2.93	10.50	3.18	11.10	3.43	11.35	3.44	11.59	3.47
	35.00	7.27	2.09	8.58	2.60	9.90	3.12	10.50	3.38	11.10	3.64	11.35	3.65	11.59	3.69
	37.00	7.27	2.22	8.58	2.77	9.90	3.31	10.50	3.59	11.10	3.88	11.35	3.89	11.59	3.92
	39.00	7.27	2.23	8.58	2.78	9.90	3.33	10.50	3.61	11.10	3.89	11.35	3.90	11.59	3.94
41.00	7.27	2.24	8.58	2.79	9.90	3.34	10.50	3.63	11.10	3.91	11.35	3.92	11.59	3.96	
43.00	7.27	2.25	8.58	2.81	9.90	3.36	10.50	3.64	11.10	3.93	11.35	3.94	11.59	3.98	
90%	10.00	6.54	0.98	7.73	1.21	8.91	1.45	9.45	1.58	9.99	1.70	10.21	1.71	10.43	1.72
	12.00	6.54	0.99	7.73	1.24	8.91	1.48	9.45	1.61	9.99	1.73	10.21	1.74	10.43	1.75
	14.00	6.54	1.01	7.73	1.26	8.91	1.51	9.45	1.64	9.99	1.76	10.21	1.77	10.43	1.79
	16.00	6.54	1.03	7.73	1.28	8.91	1.54	9.45	1.67	9.99	1.80	10.21	1.80	10.43	1.82
	18.00	6.54	1.05	7.73	1.30	8.91	1.56	9.45	1.69	9.99	1.83	10.21	1.83	10.43	1.85
	19.00	6.54	1.07	7.73	1.33	8.91	1.59	9.45	1.72	9.99	1.86	10.21	1.86	10.43	1.88
	21.00	6.54	1.14	7.73	1.42	8.91	1.70	9.45	1.85	9.99	1.99	10.21	2.00	10.43	2.02
	23.00	6.54	1.22	7.73	1.52	8.91	1.83	9.45	1.98	9.99	2.13	10.21	2.14	10.43	2.16
	25.00	6.54	1.31	7.73	1.63	8.91	1.95	9.45	2.12	9.99	2.28	10.21	2.29	10.43	2.31
	27.00	6.54	1.40	7.73	1.74	8.91	2.09	9.45	2.26	9.99	2.44	10.21	2.45	10.43	2.47
	29.00	6.54	1.49	7.73	1.86	8.91	2.23	9.45	2.42	9.99	2.61	10.21	2.61	10.43	2.64
	31.00	6.54	1.59	7.73	1.99	8.91	2.38	9.45	2.58	9.99	2.78	10.21	2.79	10.43	2.82
	33.00	6.54	1.70	7.73	2.11	8.91	2.53	9.45	2.75	9.99	2.96	10.21	2.97	10.43	3.00
	35.00	6.54	1.81	7.73	2.25	8.91	2.69	9.45	2.92	9.99	3.15	10.21	3.16	10.43	3.19
	37.00	6.54	1.92	7.73	2.39	8.91	2.87	9.45	3.11	9.99	3.35	10.21	3.36	10.43	3.39
	39.00	6.54	1.93	7.73	2.40	8.91	2.88	9.45	3.12	9.99	3.36	10.21	3.38	10.43	3.41
41.00	6.54	1.94	7.73	2.41	8.91	2.89	9.45	3.14	9.99	3.38	10.21	3.39	10.43	3.42	
43.00	6.54	1.95	7.73	2.43	8.91	2.90	9.45	3.15	9.99	3.40	10.21	3.41	10.43	3.44	
80%	10.00	5.82	0.83	6.87	1.04	7.92	1.24	8.40	1.35	8.88	1.45	9.08	1.46	9.27	1.47
	12.00	5.82	0.85	6.87	1.06	7.92	1.27	8.40	1.37	8.88	1.48	9.08	1.48	9.27	1.50
	14.00	5.82	0.86	6.87	1.08	7.92	1.29	8.40	1.40	8.88	1.51	9.08	1.51	9.27	1.53
	16.00	5.82	0.88	6.87	1.10	7.92	1.31	8.40	1.42	8.88	1.53	9.08	1.54	9.27	1.55
	18.00	5.82	0.89	6.87	1.11	7.92	1.33	8.40	1.45	8.88	1.56	9.08	1.57	9.27	1.58
	19.00	5.82	0.91	6.87	1.13	7.92	1.36	8.40	1.47	8.88	1.59	9.08	1.59	9.27	1.61
	21.00	5.82	0.98	6.87	1.22	7.92	1.46	8.40	1.58	8.88	1.70	9.08	1.71	9.27	1.72
	23.00	5.82	1.05	6.87	1.30	7.92	1.56	8.40	1.69	8.88	1.82	9.08	1.83	9.27	1.85
	25.00	5.82	1.12	6.87	1.39	7.92	1.67	8.40	1.81	8.88	1.95	9.08	1.96	9.27	1.98
	27.00	5.82	1.20	6.87	1.49	7.92	1.78	8.40	1.93	8.88	2.09	9.08	2.09	9.27	2.11
	29.00	5.82	1.28	6.87	1.59	7.92	1.90	8.40	2.07	8.88	2.23	9.08	2.23	9.27	2.26
	31.00	5.82	1.36	6.87	1.70	7.92	2.03	8.40	2.20	8.88	2.37	9.08	2.38	9.27	2.40
	33.00	5.82	1.45	6.87	1.81	7.92	2.16	8.40	2.35	8.88	2.53	9.08	2.54	9.27	2.56
	35.00	5.82	1.54	6.87	1.92	7.92	2.30	8.40	2.50	8.88	2.69	9.08	2.70	9.27	2.73
	37.00	5.82	1.64	6.87	2.04	7.92	2.45	8.40	2.65	8.88	2.86	9.08	2.87	9.27	2.90
	39.00	5.82	1.65	6.87	2.05	7.92	2.46	8.40	2.67	8.88	2.87	9.08	2.88	9.27	2.91
41.00	5.82	1.66	6.87	2.06	7.92	2.47	8.40	2.68	8.88	2.89	9.08	2.90	9.27	2.92	
43.00	5.82	1.66	6.87	2.07	7.92	2.48	8.40	2.69	8.88	2.90	9.08	2.91	9.27	2.94	

70%	10.00	5.09	0.70	6.01	0.87	6.93	1.05	7.35	1.14	7.77	1.22	7.94	1.23	8.11	1.24
	12.00	5.09	0.71	6.01	0.89	6.93	1.07	7.35	1.16	7.77	1.25	7.94	1.25	8.11	1.26
	14.00	5.09	0.73	6.01	0.91	6.93	1.09	7.35	1.18	7.77	1.27	7.94	1.27	8.11	1.29
	16.00	5.09	0.74	6.01	0.92	6.93	1.10	7.35	1.20	7.77	1.29	7.94	1.30	8.11	1.31
	18.00	5.09	0.75	6.01	0.94	6.93	1.12	7.35	1.22	7.77	1.31	7.94	1.32	8.11	1.33
	19.00	5.09	0.77	6.01	0.95	6.93	1.14	7.35	1.24	7.77	1.34	7.94	1.34	8.11	1.35
	21.00	5.09	0.82	6.01	1.02	6.93	1.23	7.35	1.33	7.77	1.43	7.94	1.44	8.11	1.45
	23.00	5.09	0.88	6.01	1.10	6.93	1.31	7.35	1.42	7.77	1.54	7.94	1.54	8.11	1.55
	25.00	5.09	0.94	6.01	1.17	6.93	1.40	7.35	1.52	7.77	1.64	7.94	1.65	8.11	1.66
	27.00	5.09	1.01	6.01	1.25	6.93	1.50	7.35	1.63	7.77	1.76	7.94	1.76	8.11	1.78
	29.00	5.09	1.07	6.01	1.34	6.93	1.60	7.35	1.74	7.77	1.87	7.94	1.88	8.11	1.90
	31.00	5.09	1.15	6.01	1.43	6.93	1.71	7.35	1.85	7.77	2.00	7.94	2.01	8.11	2.03
	33.00	5.09	1.22	6.01	1.52	6.93	1.82	7.35	1.98	7.77	2.13	7.94	2.14	8.11	2.16
	35.00	5.09	1.30	6.01	1.62	6.93	1.94	7.35	2.10	7.77	2.27	7.94	2.27	8.11	2.29
	37.00	5.09	1.38	6.01	1.72	6.93	2.06	7.35	2.24	7.77	2.41	7.94	2.42	8.11	2.44
39.00	5.09	1.39	6.01	1.73	6.93	2.07	7.35	2.25	7.77	2.42	7.94	2.43	8.11	2.45	
41.00	5.09	1.39	6.01	1.74	6.93	2.08	7.35	2.26	7.77	2.43	7.94	2.44	8.11	2.46	
43.00	5.09	1.40	6.01	1.74	6.93	2.09	7.35	2.27	7.77	2.44	7.94	2.45	8.11	2.47	
60%	10.00	4.36	0.58	5.15	0.72	5.94	0.87	6.30	0.94	6.66	1.01	6.81	1.02	6.95	1.03
	12.00	4.36	0.59	5.15	0.74	5.94	0.88	6.30	0.96	6.66	1.03	6.81	1.03	6.95	1.04
	14.00	4.36	0.60	5.15	0.75	5.94	0.90	6.30	0.97	6.66	1.05	6.81	1.05	6.95	1.06
	16.00	4.36	0.61	5.15	0.76	5.94	0.91	6.30	0.99	6.66	1.07	6.81	1.07	6.95	1.08
	18.00	4.36	0.62	5.15	0.78	5.94	0.93	6.30	1.01	6.66	1.09	6.81	1.09	6.95	1.10
	19.00	4.36	0.63	5.15	0.79	5.94	0.95	6.30	1.03	6.66	1.11	6.81	1.11	6.95	1.12
	21.00	4.36	0.68	5.15	0.85	5.94	1.01	6.30	1.10	6.66	1.19	6.81	1.19	6.95	1.20
	23.00	4.36	0.73	5.15	0.91	5.94	1.09	6.30	1.18	6.66	1.27	6.81	1.27	6.95	1.29
	25.00	4.36	0.78	5.15	0.97	5.94	1.16	6.30	1.26	6.66	1.36	6.81	1.36	6.95	1.38
	27.00	4.36	0.83	5.15	1.04	5.94	1.24	6.30	1.35	6.66	1.45	6.81	1.46	6.95	1.47
	29.00	4.36	0.89	5.15	1.11	5.94	1.33	6.30	1.44	6.66	1.55	6.81	1.56	6.95	1.57
	31.00	4.36	0.95	5.15	1.18	5.94	1.42	6.30	1.54	6.66	1.66	6.81	1.66	6.95	1.68
	33.00	4.36	1.01	5.15	1.26	5.94	1.51	6.30	1.64	6.66	1.76	6.81	1.77	6.95	1.79
	35.00	4.36	1.08	5.15	1.34	5.94	1.60	6.30	1.74	6.66	1.88	6.81	1.88	6.95	1.90
	37.00	4.36	1.14	5.15	1.42	5.94	1.71	6.30	1.85	6.66	1.99	6.81	2.00	6.95	2.02
39.00	4.36	1.15	5.15	1.43	5.94	1.71	6.30	1.86	6.66	2.00	6.81	2.01	6.95	2.03	
41.00	4.36	1.15	5.15	1.44	5.94	1.72	6.30	1.87	6.66	2.01	6.81	2.02	6.95	2.04	
43.00	4.36	1.16	5.15	1.44	5.94	1.73	6.30	1.88	6.66	2.02	6.81	2.03	6.95	2.05	
50%	10.00	3.64	0.47	4.29	0.59	4.95	0.70	5.25	0.76	5.55	0.82	5.67	0.82	5.79	0.83
	12.00	3.64	0.48	4.29	0.60	4.95	0.71	5.25	0.78	5.55	0.84	5.67	0.84	5.79	0.85
	14.00	3.64	0.49	4.29	0.61	4.95	0.73	5.25	0.79	5.55	0.85	5.67	0.85	5.79	0.86
	16.00	3.64	0.50	4.29	0.62	4.95	0.74	5.25	0.80	5.55	0.87	5.67	0.87	5.79	0.88
	18.00	3.64	0.51	4.29	0.63	4.95	0.75	5.25	0.82	5.55	0.88	5.67	0.88	5.79	0.89
	19.00	3.64	0.51	4.29	0.64	4.95	0.77	5.25	0.83	5.55	0.90	5.67	0.90	5.79	0.91
	21.00	3.64	0.55	4.29	0.69	4.95	0.82	5.25	0.89	5.55	0.96	5.67	0.96	5.79	0.97
	23.00	3.64	0.59	4.29	0.74	4.95	0.88	5.25	0.95	5.55	1.03	5.67	1.03	5.79	1.04
	25.00	3.64	0.63	4.29	0.79	4.95	0.94	5.25	1.02	5.55	1.10	5.67	1.10	5.79	1.12
	27.00	3.64	0.68	4.29	0.84	4.95	1.01	5.25	1.09	5.55	1.18	5.67	1.18	5.79	1.19
	29.00	3.64	0.72	4.29	0.90	4.95	1.08	5.25	1.17	5.55	1.26	5.67	1.26	5.79	1.27
	31.00	3.64	0.77	4.29	0.96	4.95	1.15	5.25	1.24	5.55	1.34	5.67	1.34	5.79	1.36
	33.00	3.64	0.82	4.29	1.02	4.95	1.22	5.25	1.32	5.55	1.43	5.67	1.43	5.79	1.45
	35.00	3.64	0.87	4.29	1.09	4.95	1.30	5.25	1.41	5.55	1.52	5.67	1.52	5.79	1.54
	37.00	3.64	0.93	4.29	1.15	4.95	1.38	5.25	1.50	5.55	1.62	5.67	1.62	5.79	1.64
39.00	3.64	0.93	4.29	1.16	4.95	1.39	5.25	1.51	5.55	1.62	5.67	1.63	5.79	1.64	
41.00	3.64	0.93	4.29	1.16	4.95	1.39	5.25	1.51	5.55	1.63	5.67	1.64	5.79	1.65	
43.00	3.64	0.94	4.29	1.17	4.95	1.40	5.25	1.52	5.55	1.64	5.67	1.64	5.79	1.66	

Heating

Combination (Capacity index)	Outdoor air temp.		Indoor temperature(°C DB)											
			16		18		20		21		22		24	
	°C DB	°C WB	TC	PI	TC	PI	TC	PI	TC	PI	TC	PI	TC	PI
130%	-14.7	-15	8.03	3.17	8.03	3.23	8.03	3.30	7.71	3.16	7.39	3.01	6.76	2.72
	-12.6	-13	8.48	3.22	8.48	3.29	8.48	3.36	8.14	3.21	7.81	3.06	7.13	2.77
	-10.5	-11	8.93	3.27	8.93	3.34	8.93	3.41	8.57	3.26	8.22	3.11	7.51	2.81
	-9.5	-10	9.14	3.29	9.14	3.37	9.14	3.44	8.78	3.28	8.41	3.13	7.69	2.83
	-8.5	-9.1	9.35	3.32	9.35	3.39	9.35	3.46	8.98	3.31	8.61	3.16	7.87	2.85
	-7	-7.6	9.67	3.36	9.67	3.43	9.67	3.50	9.29	3.35	8.90	3.19	8.14	2.89
	-5	-5.6	10.10	3.41	10.10	3.48	10.10	3.55	9.70	3.40	9.29	3.24	8.49	2.93
	-3	-3.7	10.52	3.46	10.52	3.53	10.52	3.60	10.10	3.45	9.69	3.29	8.85	2.97
	0	-0.7	11.16	3.53	11.16	3.61	11.16	3.68	10.72	3.52	10.27	3.36	9.39	3.04
	3	2.2	11.80	3.61	11.80	3.68	11.80	3.76	11.33	3.60	10.86	3.43	9.93	3.10
	5	4.1	12.22	3.66	12.22	3.73	12.22	3.81	11.74	3.64	11.25	3.48	10.28	3.14
	7	6	12.65	3.71	12.65	3.78	12.65	3.86	12.15	3.69	11.65	3.53	10.64	3.19
	9	7.9	12.65	3.58	12.65	3.66	12.65	3.73	12.15	3.57	11.65	3.41	10.64	3.08
	11	9.8	12.65	3.46	12.65	3.53	12.65	3.60	12.15	3.45	11.65	3.29	10.64	2.97
	13	11.8	12.65	3.33	12.65	3.40	12.65	3.47	12.15	3.32	11.65	3.17	10.64	2.87
15	13.7	12.65	3.21	12.65	3.28	12.65	3.34	12.15	3.20	11.65	3.05	10.64	2.76	
120%	-14.7	-15	8.03	3.26	8.03	3.33	8.03	3.40	7.71	3.25	7.39	3.10	6.76	2.80
	-12.6	-13	8.48	3.31	8.48	3.38	8.48	3.45	8.14	3.30	7.81	3.15	7.13	2.85
	-10.5	-11	8.93	3.37	8.93	3.44	8.93	3.51	8.57	3.36	8.22	3.20	7.51	2.89
	-9.5	-10	9.14	3.39	9.14	3.46	9.14	3.54	8.78	3.38	8.41	3.23	7.69	2.92
	-8.5	-9.1	9.35	3.42	9.35	3.49	9.35	3.56	8.98	3.41	8.61	3.25	7.87	2.94
	-7	-7.6	9.67	3.46	9.67	3.53	9.67	3.60	9.29	3.45	8.90	3.29	8.14	2.97
	-5	-5.6	10.10	3.51	10.10	3.58	10.10	3.66	9.70	3.50	9.29	3.34	8.49	3.02
	-3	-3.7	10.52	3.56	10.52	3.63	10.52	3.71	10.10	3.55	9.69	3.39	8.85	3.06
	0	-0.7	11.16	3.64	11.16	3.71	11.16	3.79	10.72	3.62	10.27	3.46	9.39	3.13
	3	2.2	11.80	3.71	11.80	3.79	11.80	3.87	11.33	3.70	10.86	3.53	9.93	3.19
	5	4.1	12.22	3.76	12.22	3.84	12.22	3.92	11.74	3.75	11.25	3.58	10.28	3.24
	7	6	12.65	3.81	12.65	3.90	12.65	3.98	12.15	3.80	11.65	3.63	10.64	3.28
	9	7.9	12.65	3.69	12.65	3.77	12.65	3.84	12.15	3.68	11.65	3.51	10.64	3.17
	11	9.8	12.65	3.56	12.65	3.63	12.65	3.71	12.15	3.55	11.65	3.39	10.64	3.06
	13	11.8	12.65	3.43	12.65	3.50	12.65	3.58	12.15	3.42	11.65	3.26	10.64	2.95
15	13.7	12.65	3.30	12.65	3.37	12.65	3.44	12.15	3.29	11.65	3.14	10.64	2.84	
110%	-14.7	-15	8.03	3.35	8.03	3.42	8.03	3.49	7.71	3.34	7.39	3.19	6.76	2.88
	-12.6	-13	8.48	3.41	8.48	3.48	8.48	3.55	8.14	3.40	7.81	3.24	7.13	2.93
	-10.5	-11	8.93	3.46	8.93	3.54	8.93	3.61	8.57	3.45	8.22	3.29	7.51	2.98
	-9.5	-10	9.14	3.49	9.14	3.56	9.14	3.64	8.78	3.48	8.41	3.32	7.69	3.00
	-8.5	-9.1	9.35	3.52	9.35	3.59	9.35	3.67	8.98	3.50	8.61	3.34	7.87	3.02
	-7	-7.6	9.67	3.55	9.67	3.63	9.67	3.71	9.29	3.54	8.90	3.38	8.14	3.06
	-5	-5.6	10.10	3.61	10.10	3.68	10.10	3.76	9.70	3.60	9.29	3.43	8.49	3.10
	-3	-3.7	10.52	3.66	10.52	3.74	10.52	3.82	10.10	3.65	9.69	3.48	8.85	3.15
	0	-0.7	11.16	3.74	11.16	3.82	11.16	3.90	10.72	3.73	10.27	3.56	9.39	3.22
	3	2.2	11.80	3.82	11.80	3.90	11.80	3.98	11.33	3.81	10.86	3.63	9.93	3.28
	5	4.1	12.22	3.87	12.22	3.95	12.22	4.04	11.74	3.86	11.25	3.68	10.28	3.33
	7	6	12.65	3.92	12.65	4.01	12.65	4.09	12.15	3.91	11.65	3.73	10.64	3.37
	9	7.9	12.65	3.79	12.65	3.87	12.65	3.95	12.15	3.78	11.65	3.61	10.64	3.26
	11	9.8	12.65	3.66	12.65	3.74	12.65	3.82	12.15	3.65	11.65	3.48	10.64	3.15
	13	11.8	12.65	3.53	12.65	3.60	12.65	3.68	12.15	3.52	11.65	3.36	10.64	3.03
15	13.7	12.65	3.40	12.65	3.47	12.65	3.54	12.15	3.39	11.65	3.23	10.64	2.92	
100%	-14.7	-15	7.30	2.96	7.30	3.02	7.30	3.08	7.01	2.95	6.72	2.81	6.14	2.54
	-12.6	-13	7.71	3.01	7.71	3.07	7.71	3.13	7.40	3.00	7.10	2.86	6.48	2.59
	-10.5	-11	8.11	3.06	8.11	3.12	8.11	3.19	7.79	3.05	7.47	2.91	6.83	2.63

	-9.5	-10	8.31	3.08	8.31	3.14	8.31	3.21	7.98	3.07	7.65	2.93	6.99	2.65
	-8.5	-9.1	8.50	3.10	8.50	3.17	8.50	3.23	8.16	3.09	7.83	2.95	7.15	2.67
	-7	-7.6	8.79	3.14	8.79	3.20	8.79	3.27	8.44	3.13	8.09	2.98	7.40	2.70
	-5	-5.6	9.18	3.18	9.18	3.25	9.18	3.32	8.81	3.17	8.45	3.03	7.72	2.74
	-3	-3.7	9.57	3.23	9.57	3.30	9.57	3.37	9.19	3.22	8.81	3.07	8.05	2.78
	0	-0.7	10.15	3.30	10.15	3.37	10.15	3.44	9.74	3.29	9.34	3.14	8.54	2.84
	3	2.2	10.73	3.37	10.73	3.44	10.73	3.51	10.30	3.36	9.87	3.21	9.02	2.90
	5	4.1	11.11	3.42	11.11	3.49	11.11	3.56	10.67	3.41	10.23	3.25	9.35	2.94
	7	6	11.50	3.46	11.50	3.54	11.50	3.61	11.04	3.45	10.59	3.29	9.67	2.98
	9	7.9	11.50	3.35	11.50	3.42	11.50	3.49	11.04	3.34	10.59	3.18	9.67	2.88
	11	9.8	11.50	3.23	11.50	3.30	11.50	3.37	11.04	3.22	10.59	3.07	9.67	2.78
	13	11.8	11.50	3.11	11.50	3.18	11.50	3.25	11.04	3.10	10.59	2.96	9.67	2.68
	15	13.7	11.50	3.00	11.50	3.06	11.50	3.13	11.04	2.99	10.59	2.85	9.67	2.58
90%	-14.7	-15	6.57	2.62	6.57	2.68	6.57	2.73	6.31	2.61	6.05	2.49	5.53	2.25
	-12.6	-13	6.94	2.67	6.94	2.72	6.94	2.78	6.66	2.66	6.39	2.54	5.84	2.29
	-10.5	-11	7.30	2.71	7.30	2.77	7.30	2.82	7.01	2.70	6.72	2.58	6.14	2.33
	-9.5	-10	7.48	2.73	7.48	2.79	7.48	2.85	7.18	2.72	6.88	2.60	6.29	2.35
	-8.5	-9.1	7.65	2.75	7.65	2.81	7.65	2.87	7.35	2.74	7.04	2.62	6.44	2.36
	-7	-7.6	7.91	2.78	7.91	2.84	7.91	2.90	7.60	2.77	7.28	2.65	6.66	2.39
	-5	-5.6	8.26	2.82	8.26	2.88	8.26	2.94	7.93	2.81	7.60	2.68	6.95	2.43
	-3	-3.7	8.61	2.86	8.61	2.92	8.61	2.99	8.27	2.85	7.93	2.72	7.24	2.46
	0	-0.7	9.13	2.93	9.13	2.99	9.13	3.05	8.77	2.92	8.41	2.78	7.68	2.52
	3	2.2	9.65	2.99	9.65	3.05	9.65	3.11	9.27	2.98	8.89	2.84	8.12	2.57
	5	4.1	10.00	3.03	10.00	3.09	10.00	3.16	9.60	3.02	9.21	2.88	8.41	2.60
	7	6	10.35	3.07	10.35	3.14	10.35	3.20	9.94	3.06	9.53	2.92	8.71	2.64
	9	7.9	10.35	2.97	10.35	3.03	10.35	3.09	9.94	2.96	9.53	2.82	8.71	2.55
	11	9.8	10.35	2.86	10.35	2.92	10.35	2.99	9.94	2.86	9.53	2.72	8.71	2.46
	13	11.8	10.35	2.76	10.35	2.82	10.35	2.88	9.94	2.75	9.53	2.63	8.71	2.37
15	13.7	10.35	2.66	10.35	2.71	10.35	2.77	9.94	2.65	9.53	2.53	8.71	2.29	
80%	-14.7	-15	5.84	2.30	5.84	2.35	5.84	2.40	5.61	2.30	5.38	2.19	4.91	1.98
	-12.6	-13	6.17	2.34	6.17	2.39	6.17	2.44	5.92	2.33	5.68	2.23	5.19	2.01
	-10.5	-11	6.49	2.38	6.49	2.43	6.49	2.48	6.23	2.37	5.98	2.26	5.46	2.05
	-9.5	-10	6.65	2.40	6.65	2.45	6.65	2.50	6.38	2.39	6.12	2.28	5.59	2.06
	-8.5	-9.1	6.80	2.41	6.80	2.47	6.80	2.52	6.53	2.41	6.26	2.30	5.72	2.08
	-7	-7.6	7.03	2.44	7.03	2.49	7.03	2.55	6.75	2.43	6.47	2.32	5.92	2.10
	-5	-5.6	7.34	2.48	7.34	2.53	7.34	2.58	7.05	2.47	6.76	2.36	6.18	2.13
	-3	-3.7	7.65	2.51	7.65	2.57	7.65	2.62	7.35	2.51	7.04	2.39	6.44	2.16
	0	-0.7	8.12	2.57	8.12	2.62	8.12	2.68	7.79	2.56	7.47	2.44	6.83	2.21
	3	2.2	8.58	2.62	8.58	2.68	8.58	2.74	8.24	2.62	7.90	2.50	7.22	2.26
	5	4.1	8.89	2.66	8.89	2.72	8.89	2.77	8.54	2.65	8.18	2.53	7.48	2.29
	7	6	9.20	2.70	9.20	2.75	9.20	2.81	8.83	2.69	8.47	2.56	7.74	2.32
	9	7.9	9.20	2.61	9.20	2.66	9.20	2.72	8.83	2.60	8.47	2.48	7.74	2.24
	11	9.8	9.20	2.51	9.20	2.57	9.20	2.62	8.83	2.51	8.47	2.39	7.74	2.16
	13	11.8	9.20	2.42	9.20	2.48	9.20	2.53	8.83	2.42	8.47	2.31	7.74	2.08
15	13.7	9.20	2.33	9.20	2.38	9.20	2.43	8.83	2.33	8.47	2.22	7.74	2.01	
70%	-14.7	-15	5.11	1.98	5.11	2.03	5.11	2.07	4.91	1.98	4.71	1.89	4.30	1.71
	-12.6	-13	5.40	2.02	5.40	2.06	5.40	2.10	5.18	2.01	4.97	1.92	4.54	1.73
	-10.5	-11	5.68	2.05	5.68	2.09	5.68	2.14	5.45	2.04	5.23	1.95	4.78	1.76
	-9.5	-10	5.82	2.06	5.82	2.11	5.82	2.15	5.58	2.06	5.35	1.96	4.89	1.77
	-8.5	-9.1	5.95	2.08	5.95	2.12	5.95	2.17	5.71	2.07	5.48	1.98	5.01	1.79
	-7	-7.6	6.15	2.10	6.15	2.15	6.15	2.19	5.91	2.10	5.67	2.00	5.18	1.81
	-5	-5.6	6.42	2.13	6.42	2.18	6.42	2.23	6.17	2.13	5.91	2.03	5.41	1.84
	-3	-3.7	6.70	2.17	6.70	2.21	6.70	2.26	6.43	2.16	6.16	2.06	5.63	1.86
	0	-0.7	7.10	2.21	7.10	2.26	7.10	2.31	6.82	2.21	6.54	2.10	5.97	1.90
	3	2.2	7.51	2.26	7.51	2.31	7.51	2.36	7.21	2.25	6.91	2.15	6.32	1.94
	5	4.1	7.78	2.29	7.78	2.34	7.78	2.39	7.47	2.28	7.16	2.18	6.54	1.97
7	6	8.05	2.32	8.05	2.37	8.05	2.42	7.73	2.31	7.41	2.21	6.77	2.00	
9	7.9	8.05	2.24	8.05	2.29	8.05	2.34	7.73	2.24	7.41	2.13	6.77	1.93	

	11	9.8	8.05	2.17	8.05	2.21	8.05	2.26	7.73	2.16	7.41	2.06	6.77	1.86
	13	11.8	8.05	2.09	8.05	2.13	8.05	2.18	7.73	2.08	7.41	1.99	6.77	1.80
	15	13.7	8.05	2.01	8.05	2.05	8.05	2.10	7.73	2.00	7.41	1.91	6.77	1.73
60%	-14.7	-15	4.38	1.66	4.38	1.70	4.38	1.73	4.21	1.66	4.03	1.58	3.69	1.43
	-12.6	-13	4.62	1.69	4.62	1.73	4.62	1.76	4.44	1.69	4.26	1.61	3.89	1.45
	-10.5	-11	4.87	1.72	4.87	1.75	4.87	1.79	4.68	1.71	4.48	1.63	4.10	1.48
	-9.5	-10	4.98	1.73	4.98	1.77	4.98	1.81	4.79	1.73	4.59	1.65	4.19	1.49
	-8.5	-9.1	5.10	1.74	5.10	1.78	5.10	1.82	4.90	1.74	4.70	1.66	4.29	1.50
	-7	-7.6	5.27	1.76	5.27	1.80	5.27	1.84	5.07	1.76	4.86	1.68	4.44	1.52
	-5	-5.6	5.51	1.79	5.51	1.83	5.51	1.87	5.29	1.78	5.07	1.70	4.63	1.54
	-3	-3.7	5.74	1.82	5.74	1.86	5.74	1.89	5.51	1.81	5.28	1.73	4.83	1.56
	0	-0.7	6.09	1.86	6.09	1.90	6.09	1.93	5.85	1.85	5.60	1.77	5.12	1.60
	3	2.2	6.44	1.89	6.44	1.94	6.44	1.98	6.18	1.89	5.92	1.80	5.41	1.63
	5	4.1	6.67	1.92	6.67	1.96	6.67	2.00	6.40	1.92	6.14	1.83	5.61	1.65
	7	6	6.90	1.95	6.90	1.99	6.90	2.03	6.63	1.94	6.35	1.85	5.80	1.67
	9	7.9	6.90	1.88	6.90	1.92	6.90	1.96	6.63	1.88	6.35	1.79	5.80	1.62
	11	9.8	6.90	1.82	6.90	1.86	6.90	1.89	6.63	1.81	6.35	1.73	5.80	1.56
	13	11.8	6.90	1.75	6.90	1.79	6.90	1.83	6.63	1.75	6.35	1.67	5.80	1.51
15	13.7	6.90	1.69	6.90	1.72	6.90	1.76	6.63	1.68	6.35	1.60	5.80	1.45	
50%	-14.7	-15	3.65	1.34	3.65	1.37	3.65	1.40	3.51	1.34	3.36	1.28	3.07	1.16
	-12.6	-13	3.85	1.37	3.85	1.39	3.85	1.42	3.70	1.36	3.55	1.30	3.24	1.17
	-10.5	-11	4.06	1.39	4.06	1.42	4.06	1.45	3.90	1.38	3.74	1.32	3.41	1.19
	-9.5	-10	4.15	1.40	4.15	1.43	4.15	1.46	3.99	1.39	3.82	1.33	3.49	1.20
	-8.5	-9.1	4.25	1.41	4.25	1.44	4.25	1.47	4.08	1.40	3.91	1.34	3.58	1.21
	-7	-7.6	4.40	1.42	4.40	1.46	4.40	1.49	4.22	1.42	4.05	1.36	3.70	1.23
	-5	-5.6	4.59	1.45	4.59	1.48	4.59	1.51	4.41	1.44	4.22	1.38	3.86	1.24
	-3	-3.7	4.78	1.47	4.78	1.50	4.78	1.53	4.59	1.46	4.40	1.40	4.02	1.26
	0	-0.7	5.07	1.50	5.07	1.53	5.07	1.56	4.87	1.49	4.67	1.43	4.27	1.29
	3	2.2	5.36	1.53	5.36	1.56	5.36	1.60	5.15	1.53	4.94	1.46	4.51	1.32
	5	4.1	5.56	1.55	5.56	1.58	5.56	1.62	5.34	1.55	5.12	1.48	4.67	1.33
	7	6	5.75	1.57	5.75	1.61	5.75	1.64	5.52	1.57	5.29	1.50	4.84	1.35
	9	7.9	5.75	1.52	5.75	1.55	5.75	1.58	5.52	1.52	5.29	1.45	4.84	1.31
	11	9.8	5.75	1.47	5.75	1.50	5.75	1.53	5.52	1.46	5.29	1.40	4.84	1.26
	13	11.8	5.75	1.41	5.75	1.44	5.75	1.47	5.52	1.41	5.29	1.35	4.84	1.22
15	13.7	5.75	1.36	5.75	1.39	5.75	1.42	5.52	1.36	5.29	1.30	4.84	1.17	

MDV-V140W/BDRN1

Cooling

Combination (Capacity index)	Outdoor temperature (°C DB)	Indoor temperature(°C WB)													
		14.00		16.00		18.00		19.00		20.00		22.00		24.00	
		TC	PI	TC	PI	TC	PI	TC	PI	TC	PI	TC	PI	TC	PI
		kW	kW	kW	kW	kW	kW	kW	kW	kW	kW	kW	kW	kW	kW
130%	10.00	10.63	1.49	12.55	1.85	14.47	2.22	15.35	2.41	16.23	2.59	16.59	2.60	16.94	2.63
	12.00	10.63	1.51	12.55	1.89	14.47	2.26	15.35	2.45	16.23	2.64	16.59	2.65	16.94	2.68
	14.00	10.63	1.54	12.55	1.92	14.47	2.30	15.35	2.50	16.23	2.69	16.59	2.70	16.94	2.73
	16.00	10.63	1.57	12.55	1.96	14.47	2.34	15.35	2.54	16.23	2.74	16.59	2.75	16.94	2.77
	18.00	10.63	1.60	12.55	1.99	14.47	2.38	15.35	2.59	16.23	2.79	16.59	2.80	16.94	2.82
	19.00	10.63	1.63	12.55	2.02	14.47	2.42	15.35	2.63	16.23	2.83	16.59	2.84	16.94	2.87
	21.00	10.63	1.74	12.55	2.17	14.47	2.60	15.35	2.82	16.23	3.04	16.59	3.05	16.94	3.08
	23.00	10.63	1.87	12.55	2.33	14.47	2.78	15.35	3.02	16.23	3.26	16.59	3.27	16.94	3.30
	25.00	10.63	1.40	12.55	2.49	14.47	2.98	15.35	3.23	16.23	3.48	16.59	3.49	16.94	3.53
	27.00	10.63	2.13	12.55	2.66	14.47	3.18	15.35	3.45	16.23	3.72	16.59	3.73	16.94	3.77
	29.00	10.63	2.28	12.55	2.84	14.47	3.40	15.35	3.69	16.23	3.98	16.59	3.99	16.94	4.03
	31.00	10.63	2.43	12.55	3.03	14.47	3.63	15.35	3.93	16.23	4.24	16.59	4.25	16.94	4.29
	33.00	10.63	2.59	12.55	3.23	14.47	3.86	15.35	4.19	16.23	4.52	16.59	4.53	16.94	4.57
	35.00	10.63	2.75	12.55	3.43	14.47	4.11	15.35	4.46	16.23	4.80	16.59	4.82	16.94	4.87
	37.00	10.63	2.93	12.55	3.65	14.47	4.37	15.35	4.74	16.23	5.11	16.59	5.13	16.94	5.18
39.00	10.63	2.94	12.55	3.67	14.47	4.39	15.35	4.76	16.23	5.13	16.59	5.15	16.94	5.20	
41.00	10.63	2.96	12.55	3.68	14.47	4.41	15.35	4.78	16.23	5.16	16.59	5.17	16.94	5.22	
43.00	10.63	2.97	12.55	3.70	14.47	4.43	15.35	4.80	16.23	5.18	16.59	5.20	16.94	5.25	
120%	10.00	10.46	1.47	12.34	1.84	14.23	2.20	15.10	2.38	15.97	2.57	16.32	2.58	16.66	2.60
	12.00	10.46	1.50	12.34	1.87	14.23	2.24	15.10	2.43	15.97	2.62	16.32	2.63	16.66	2.65
	14.00	10.46	1.53	12.34	1.90	14.23	2.28	15.10	2.47	15.97	2.66	16.32	2.67	16.66	2.70
	16.00	10.46	1.55	12.34	1.94	14.23	2.32	15.10	2.52	15.97	2.71	16.32	2.72	16.66	2.75
	18.00	10.46	1.58	12.34	1.97	14.23	2.36	15.10	2.56	15.97	2.76	16.32	2.77	16.66	2.80
	19.00	10.46	1.61	12.34	2.01	14.23	2.40	15.10	2.60	15.97	2.81	16.32	2.82	16.66	2.84
	21.00	10.46	1.73	12.34	2.15	14.23	2.57	15.10	2.79	15.97	3.01	16.32	3.02	16.66	3.05
	23.00	10.46	1.85	12.34	2.30	14.23	2.76	15.10	2.99	15.97	3.22	16.32	3.23	16.66	3.27
	25.00	10.46	1.98	12.34	2.46	14.23	2.95	15.10	3.20	15.97	3.45	16.32	3.46	16.66	3.49
	27.00	10.46	2.11	12.34	2.63	14.23	3.15	15.10	3.42	15.97	3.69	16.32	3.70	16.66	3.74
	29.00	10.46	2.26	12.34	2.81	14.23	3.37	15.10	3.65	15.97	3.94	16.32	3.95	16.66	3.99
	31.00	10.46	2.41	12.34	3.00	14.23	3.59	15.10	3.90	15.97	4.20	16.32	4.21	16.66	4.25
	33.00	10.46	2.56	12.34	3.19	14.23	3.83	15.10	4.15	15.97	4.47	16.32	4.49	16.66	4.53
	35.00	10.46	2.73	12.34	3.40	14.23	4.07	15.10	4.41	15.97	4.76	16.32	4.77	16.66	4.82
	37.00	10.46	2.90	12.34	3.62	14.23	4.33	15.10	4.69	15.97	5.06	16.32	5.08	16.66	5.13
39.00	10.46	2.91	12.34	3.63	14.23	4.35	15.10	4.72	15.97	5.08	16.32	5.10	16.66	5.15	
41.00	10.46	2.93	12.34	3.65	14.23	4.37	15.10	4.74	15.97	5.11	16.32	5.12	16.66	5.17	
43.00	10.46	2.94	12.34	3.66	14.23	4.39	15.10	4.76	15.97	5.13	16.32	5.15	16.66	5.20	
110%	10.00	10.29	0.74	12.14	0.93	14.00	1.11	14.85	1.21	15.71	1.30	16.05	1.30	16.39	1.32
	12.00	10.29	0.76	12.14	0.95	14.00	1.13	14.85	1.23	15.71	1.32	16.05	1.33	16.39	1.34
	14.00	10.29	0.77	12.14	0.96	14.00	1.15	14.85	1.25	15.71	1.35	16.05	1.35	16.39	1.36
	16.00	10.29	0.79	12.14	0.98	14.00	1.17	14.85	1.27	15.71	1.37	16.05	1.38	16.39	1.39
	18.00	10.29	0.80	12.14	1.00	14.00	1.19	14.85	1.29	15.71	1.40	16.05	1.40	16.39	1.41
	19.00	10.29	0.81	12.14	1.01	14.00	1.21	14.85	1.32	15.71	1.42	16.05	1.42	16.39	1.44
	21.00	10.29	0.87	12.14	1.09	14.00	1.30	14.85	1.41	15.71	1.52	16.05	1.53	16.39	1.54
	23.00	10.29	0.93	12.14	1.16	14.00	1.39	14.85	1.51	15.71	1.63	16.05	1.63	16.39	1.65
	25.00	10.29	1.00	12.14	1.25	14.00	1.49	14.85	1.62	15.71	1.74	16.05	1.75	16.39	1.77
	27.00	10.29	1.07	12.14	1.33	14.00	1.59	14.85	1.73	15.71	1.86	16.05	1.87	16.39	1.89
	29.00	10.29	1.14	12.14	1.42	14.00	1.70	14.85	1.85	15.71	1.99	16.05	2.00	16.39	2.02
	31.00	10.29	1.22	12.14	1.52	14.00	1.82	14.85	1.97	15.71	2.12	16.05	2.13	16.39	2.15
	33.00	10.29	1.30	12.14	1.62	14.00	1.93	14.85	2.10	15.71	2.26	16.05	2.27	16.39	2.29
35.00	10.29	1.38	12.14	1.72	14.00	2.06	14.85	2.23	15.71	2.41	16.05	2.41	16.39	2.44	

	37.00	10.29	1.47	12.14	1.83	14.00	2.19	14.85	2.37	15.71	2.56	16.05	2.57	16.39	2.59
	39.00	10.29	1.47	12.14	1.84	14.00	2.20	14.85	2.38	15.71	2.57	16.05	2.58	16.39	2.60
	41.00	10.29	1.48	12.14	1.84	14.00	2.21	14.85	2.39	15.71	2.58	16.05	2.59	16.39	2.61
	43.00	10.29	1.49	12.14	1.85	14.00	2.22	14.85	2.41	15.71	2.59	16.05	2.60	16.39	2.63
100%	10.00	9.70	1.36	11.45	1.70	13.20	2.03	14.00	2.20	14.81	2.38	15.13	2.38	15.45	2.41
	12.00	9.70	1.39	11.45	1.73	13.20	2.07	14.00	2.24	14.81	2.42	15.13	2.43	15.45	2.45
	14.00	9.70	1.41	11.45	1.76	13.20	2.11	14.00	2.28	14.81	2.46	15.13	2.47	15.45	2.49
	16.00	9.70	1.44	11.45	1.79	13.20	2.14	14.00	2.33	14.81	2.51	15.13	2.51	15.45	2.54
	18.00	9.70	1.46	11.45	1.82	13.20	2.18	14.00	2.37	14.81	2.55	15.13	2.56	15.45	2.58
	19.00	9.70	1.49	11.45	1.85	13.20	2.22	14.00	2.41	14.81	2.59	15.13	2.60	15.45	2.63
	21.00	9.70	1.59	11.45	1.99	13.20	2.38	14.00	2.58	14.81	2.78	15.13	2.79	15.45	2.82
	23.00	9.70	1.71	11.45	2.13	13.20	2.55	14.00	2.76	14.81	2.98	15.13	2.99	15.45	3.02
	25.00	9.70	1.83	11.45	2.28	13.20	2.73	14.00	2.96	14.81	3.19	15.13	3.20	15.45	3.23
	27.00	9.70	1.95	11.45	2.43	13.20	2.92	14.00	3.16	14.81	3.41	15.13	3.42	15.45	3.45
	29.00	9.70	2.09	11.45	2.60	13.20	3.11	14.00	3.38	14.81	3.64	15.13	3.65	15.45	3.69
	31.00	9.70	2.23	11.45	2.77	13.20	3.32	14.00	3.60	14.81	3.88	15.13	3.89	15.45	3.93
	33.00	9.70	2.37	11.45	2.95	13.20	3.54	14.00	3.84	14.81	4.13	15.13	4.15	15.45	4.19
	35.00	9.70	2.52	11.45	3.14	13.20	3.76	14.00	4.08	14.81	4.40	15.13	4.41	15.45	4.45
	37.00	9.70	2.68	11.45	3.34	13.20	4.00	14.00	4.34	14.81	4.68	15.13	4.69	15.45	4.74
	39.00	9.70	2.69	11.45	3.36	13.20	4.02	14.00	4.36	14.81	4.70	15.13	4.71	15.45	4.76
41.00	9.70	2.71	11.45	3.37	13.20	4.04	14.00	4.38	14.81	4.72	15.13	4.73	15.45	4.78	
43.00	9.70	2.72	11.45	3.39	13.20	4.06	14.00	4.40	14.81	4.74	15.13	4.76	15.45	4.80	
90%	10.00	8.73	1.18	10.30	1.47	11.88	1.76	12.60	1.90	13.32	2.05	13.61	2.06	13.90	2.08
	12.00	8.73	1.20	10.30	1.49	11.88	1.79	12.60	1.94	13.32	2.09	13.61	2.10	13.90	2.12
	14.00	8.73	1.22	10.30	1.52	11.88	1.82	12.60	1.98	13.32	2.13	13.61	2.14	13.90	2.16
	16.00	8.73	1.24	10.30	1.55	11.88	1.85	12.60	2.01	13.32	2.17	13.61	2.17	13.90	2.20
	18.00	8.73	1.26	10.30	1.58	11.88	1.89	12.60	2.05	13.32	2.21	13.61	2.21	13.90	2.23
	19.00	8.73	1.29	10.30	1.60	11.88	1.92	12.60	2.08	13.32	2.24	13.61	2.25	13.90	2.27
	21.00	8.73	1.38	10.30	1.72	11.88	2.06	12.60	2.23	13.32	2.40	13.61	2.41	13.90	2.44
	23.00	8.73	1.48	10.30	1.84	11.88	2.20	12.60	2.39	13.32	2.58	13.61	2.58	13.90	2.61
	25.00	8.73	1.58	10.30	1.97	11.88	2.36	12.60	2.56	13.32	2.76	13.61	2.77	13.90	2.79
	27.00	8.73	1.69	10.30	2.10	11.88	2.52	12.60	2.73	13.32	2.95	13.61	2.96	13.90	2.98
	29.00	8.73	1.80	10.30	2.25	11.88	2.69	12.60	2.92	13.32	3.15	13.61	3.16	13.90	3.19
	31.00	8.73	1.92	10.30	2.40	11.88	2.87	12.60	3.11	13.32	3.36	13.61	3.37	13.90	3.40
	33.00	8.73	2.05	10.30	2.55	11.88	3.06	12.60	3.32	13.32	3.57	13.61	3.59	13.90	3.62
	35.00	8.73	2.18	10.30	2.72	11.88	3.25	12.60	3.53	13.32	3.80	13.61	3.81	13.90	3.85
	37.00	8.73	2.32	10.30	2.89	11.88	3.46	12.60	3.75	13.32	4.04	13.61	4.06	13.90	4.10
	39.00	8.73	2.33	10.30	2.90	11.88	3.47	12.60	3.77	13.32	4.06	13.61	4.07	13.90	4.11
41.00	8.73	2.34	10.30	2.91	11.88	3.49	12.60	3.78	13.32	4.08	13.61	4.09	13.90	4.13	
43.00	8.73	2.35	10.30	2.93	11.88	3.51	12.60	3.80	13.32	4.10	13.61	4.11	13.90	4.15	
80%	10.00	7.76	1.01	9.16	1.25	10.56	1.50	11.20	1.63	11.84	1.75	12.10	1.76	12.36	1.78
	12.00	7.76	1.02	9.16	1.28	10.56	1.53	11.20	1.66	11.84	1.79	12.10	1.79	12.36	1.81
	14.00	7.76	1.04	9.16	1.30	10.56	1.56	11.20	1.69	11.84	1.82	12.10	1.82	12.36	1.84
	16.00	7.76	1.06	9.16	1.32	10.56	1.58	11.20	1.72	11.84	1.85	12.10	1.86	12.36	1.87
	18.00	7.76	1.08	9.16	1.35	10.56	1.61	11.20	1.75	11.84	1.88	12.10	1.89	12.36	1.91
	19.00	7.76	1.10	9.16	1.37	10.56	1.64	11.20	1.78	11.84	1.92	12.10	1.92	12.36	1.94
	21.00	7.76	1.18	9.16	1.47	10.56	1.76	11.20	1.91	11.84	2.05	12.10	2.06	12.36	2.08
	23.00	7.76	1.26	9.16	1.57	10.56	1.88	11.20	2.04	11.84	2.20	12.10	2.21	12.36	2.23
	25.00	7.76	1.35	9.16	1.68	10.56	2.01	11.20	2.18	11.84	2.35	12.10	2.36	12.36	2.38
	27.00	7.76	1.44	9.16	1.80	10.56	2.15	11.20	2.33	11.84	2.52	12.10	2.52	12.36	2.55
	29.00	7.76	1.54	9.16	1.92	10.56	2.30	11.20	2.49	11.84	2.69	12.10	2.70	12.36	2.72
	31.00	7.76	1.64	9.16	2.05	10.56	2.45	11.20	2.66	11.84	2.87	12.10	2.88	12.36	2.90
	33.00	7.76	1.75	9.16	2.18	10.56	2.61	11.20	2.83	11.84	3.05	12.10	3.06	12.36	3.09
	35.00	7.76	1.86	9.16	2.32	10.56	2.78	11.20	3.01	11.84	3.25	12.10	3.26	12.36	3.29
	37.00	7.76	1.98	9.16	2.47	10.56	2.95	11.20	3.20	11.84	3.45	12.10	3.47	12.36	3.50
	39.00	7.76	1.99	9.16	2.48	10.56	2.97	11.20	3.22	11.84	3.47	12.10	3.48	12.36	3.51
41.00	7.76	2.00	9.16	2.49	10.56	2.98	11.20	3.23	11.84	3.48	12.10	3.50	12.36	3.53	
43.00	7.76	2.01	9.16	2.50	10.56	2.99	11.20	3.25	11.84	3.50	12.10	3.51	12.36	3.55	

70%	10.00	6.79	0.85	8.01	1.05	9.24	1.26	9.80	1.37	10.36	1.48	10.59	1.48	10.81	1.50
	12.00	6.79	0.86	8.01	1.07	9.24	1.29	9.80	1.40	10.36	1.50	10.59	1.51	10.81	1.52
	14.00	6.79	0.88	8.01	1.09	9.24	1.31	9.80	1.42	10.36	1.53	10.59	1.54	10.81	1.55
	16.00	6.79	0.89	8.01	1.11	9.24	1.33	9.80	1.45	10.36	1.56	10.59	1.56	10.81	1.58
	18.00	6.79	0.91	8.01	1.13	9.24	1.36	9.80	1.47	10.36	1.59	10.59	1.59	10.81	1.61
	19.00	6.79	0.93	8.01	1.15	9.24	1.38	9.80	1.50	10.36	1.61	10.59	1.62	10.81	1.63
	21.00	6.79	0.99	8.01	1.24	9.24	1.48	9.80	1.60	10.36	1.73	10.59	1.74	10.81	1.75
	23.00	6.79	1.06	8.01	1.32	9.24	1.58	9.80	1.72	10.36	1.85	10.59	1.86	10.81	1.88
	25.00	6.79	1.14	8.01	1.42	9.24	1.70	9.80	1.84	10.36	1.98	10.59	1.99	10.81	2.01
	27.00	6.79	1.22	8.01	1.51	9.24	1.81	9.80	1.97	10.36	2.12	10.59	2.13	10.81	2.15
	29.00	6.79	1.30	8.01	1.62	9.24	1.94	9.80	2.10	10.36	2.26	10.59	2.27	10.81	2.29
	31.00	6.79	1.38	8.01	1.72	9.24	2.06	9.80	2.24	10.36	2.41	10.59	2.42	10.81	2.44
	33.00	6.79	1.47	8.01	1.84	9.24	2.20	9.80	2.38	10.36	2.57	10.59	2.58	10.81	2.60
	35.00	6.79	1.57	8.01	1.95	9.24	2.34	9.80	2.54	10.36	2.74	10.59	2.74	10.81	2.77
	37.00	6.79	1.67	8.01	2.08	9.24	2.49	9.80	2.70	10.36	2.91	10.59	2.92	10.81	2.95
39.00	6.79	1.67	8.01	2.09	9.24	2.50	9.80	2.71	10.36	2.92	10.59	2.93	10.81	2.96	
41.00	6.79	1.68	8.01	2.10	9.24	2.51	9.80	2.72	10.36	2.93	10.59	2.94	10.81	2.97	
43.00	6.79	1.69	8.01	2.11	9.24	2.52	9.80	2.74	10.36	2.95	10.59	2.96	10.81	2.99	
60%	10.00	5.82	0.70	6.87	0.87	7.92	1.05	8.40	1.13	8.88	1.22	9.08	1.23	9.27	1.24
	12.00	5.82	0.71	6.87	0.89	7.92	1.06	8.40	1.15	8.88	1.25	9.08	1.25	9.27	1.26
	14.00	5.82	0.73	6.87	0.91	7.92	1.08	8.40	1.18	8.88	1.27	9.08	1.27	9.27	1.28
	16.00	5.82	0.74	6.87	0.92	7.92	1.10	8.40	1.20	8.88	1.29	9.08	1.29	9.27	1.31
	18.00	5.82	0.75	6.87	0.94	7.92	1.12	8.40	1.22	8.88	1.31	9.08	1.32	9.27	1.33
	19.00	5.82	0.77	6.87	0.95	7.92	1.14	8.40	1.24	8.88	1.34	9.08	1.34	9.27	1.35
	21.00	5.82	0.82	6.87	1.02	7.92	1.22	8.40	1.33	8.88	1.43	9.08	1.44	9.27	1.45
	23.00	5.82	0.88	6.87	1.10	7.92	1.31	8.40	1.42	8.88	1.53	9.08	1.54	9.27	1.55
	25.00	5.82	0.94	6.87	1.17	7.92	1.40	8.40	1.52	8.88	1.64	9.08	1.65	9.27	1.66
	27.00	5.82	1.01	6.87	1.25	7.92	1.50	8.40	1.63	8.88	1.75	9.08	1.76	9.27	1.78
	29.00	5.82	1.07	6.87	1.34	7.92	1.60	8.40	1.74	8.88	1.87	9.08	1.88	9.27	1.90
	31.00	5.82	1.15	6.87	1.43	7.92	1.71	8.40	1.85	8.88	2.00	9.08	2.00	9.27	2.02
	33.00	5.82	1.22	6.87	1.52	7.92	1.82	8.40	1.97	8.88	2.13	9.08	2.13	9.27	2.16
	35.00	5.82	1.30	6.87	1.62	7.92	1.94	8.40	2.10	8.88	2.26	9.08	2.27	9.27	2.29
	37.00	5.82	1.38	6.87	1.72	7.92	2.06	8.40	2.23	8.88	2.41	9.08	2.42	9.27	2.44
39.00	5.82	1.39	6.87	1.73	7.92	2.07	8.40	2.24	8.88	2.42	9.08	2.43	9.27	2.45	
41.00	5.82	1.39	6.87	1.74	7.92	2.08	8.40	2.25	8.88	2.43	9.08	2.44	9.27	2.46	
43.00	5.82	1.40	6.87	1.74	7.92	2.09	8.40	2.26	8.88	2.44	9.08	2.45	9.27	2.47	
50%	10.00	4.85	0.57	5.72	0.71	6.60	0.85	7.00	0.92	7.40	0.99	7.56	0.99	7.72	1.00
	12.00	4.85	0.58	5.72	0.72	6.60	0.86	7.00	0.94	7.40	1.01	7.56	1.01	7.72	1.02
	14.00	4.85	0.59	5.72	0.73	6.60	0.88	7.00	0.95	7.40	1.03	7.56	1.03	7.72	1.04
	16.00	4.85	0.60	5.72	0.75	6.60	0.89	7.00	0.97	7.40	1.05	7.56	1.05	7.72	1.06
	18.00	4.85	0.61	5.72	0.76	6.60	0.91	7.00	0.99	7.40	1.06	7.56	1.07	7.72	1.08
	19.00	4.85	0.62	5.72	0.77	6.60	0.93	7.00	1.00	7.40	1.08	7.56	1.09	7.72	1.10
	21.00	4.85	0.67	5.72	0.83	6.60	0.99	7.00	1.08	7.40	1.16	7.56	1.16	7.72	1.17
	23.00	4.85	0.71	5.72	0.89	6.60	1.06	7.00	1.15	7.40	1.24	7.56	1.25	7.72	1.26
	25.00	4.85	0.76	5.72	0.95	6.60	1.14	7.00	1.23	7.40	1.33	7.56	1.33	7.72	1.35
	27.00	4.85	0.81	5.72	1.02	6.60	1.22	7.00	1.32	7.40	1.42	7.56	1.43	7.72	1.44
	29.00	4.85	0.87	5.72	1.08	6.60	1.30	7.00	1.41	7.40	1.52	7.56	1.52	7.72	1.54
	31.00	4.85	0.93	5.72	1.16	6.60	1.38	7.00	1.50	7.40	1.62	7.56	1.62	7.72	1.64
	33.00	4.85	0.99	5.72	1.23	6.60	1.47	7.00	1.60	7.40	1.72	7.56	1.73	7.72	1.75
	35.00	4.85	1.05	5.72	1.31	6.60	1.57	7.00	1.70	7.40	1.83	7.56	1.84	7.72	1.86
	37.00	4.85	1.12	5.72	1.39	6.60	1.67	7.00	1.81	7.40	1.95	7.56	1.96	7.72	1.98
39.00	4.85	1.12	5.72	1.40	6.60	1.68	7.00	1.82	7.40	1.96	7.56	1.97	7.72	1.98	
41.00	4.85	1.13	5.72	1.41	6.60	1.68	7.00	1.83	7.40	1.97	7.56	1.97	7.72	1.99	
43.00	4.85	1.13	5.72	1.41	6.60	1.69	7.00	1.83	7.40	1.98	7.56	1.98	7.72	2.00	

Heating

Combination (Capacity index)	Outdoor air temp.		Indoor temperature(°C DB)											
			16		18		20		21		22		24	
	°C DB	°C WB	TC	PI	TC	PI	TC	PI	TC	PI	TC	PI	TC	PI
			kW	kW	kW	kW	kW	kW	kW	kW	kW	kW	kW	kW
130%	-14.7	-15	10.83	3.61	10.83	3.69	10.83	3.77	10.40	3.60	9.97	3.44	9.11	3.11
	-12.6	-13	11.43	3.67	11.43	3.75	11.43	3.83	10.97	3.66	10.52	3.49	9.61	3.16
	-10.5	-11	12.03	3.73	12.03	3.81	12.03	3.89	11.55	3.72	11.08	3.55	10.12	3.21
	-9.5	-10	12.32	3.76	12.32	3.84	12.32	3.92	11.83	3.75	11.34	3.58	10.36	3.23
	-8.5	-9.1	12.60	3.79	12.60	3.87	12.60	3.95	12.10	3.78	11.60	3.60	10.60	3.26
	-7	-7.6	13.03	3.83	13.03	3.91	13.03	3.99	12.52	3.82	12.00	3.64	10.97	3.29
	-5	-5.6	13.61	3.89	13.61	3.97	13.61	4.05	13.07	3.88	12.53	3.70	11.45	3.34
	-3	-3.7	14.18	3.95	14.18	4.03	14.18	4.11	13.62	3.93	13.06	3.75	11.93	3.39
	0	-0.7	15.04	4.03	15.04	4.12	15.04	4.20	14.45	4.02	13.85	3.83	12.65	3.47
	3	2.2	15.90	4.12	15.90	4.20	15.90	4.29	15.27	4.10	14.64	3.92	13.38	3.54
	5	4.1	16.48	4.17	16.48	4.26	16.48	4.35	15.82	4.16	15.17	3.97	13.86	3.59
	7	6	17.05	4.23	17.05	4.32	17.05	4.41	16.37	4.22	15.70	4.02	14.34	3.64
	9	7.9	17.05	4.09	17.05	4.17	17.05	4.26	16.37	4.08	15.70	3.89	14.34	3.51
	11	9.8	17.05	3.95	17.05	4.03	17.05	4.11	16.37	3.93	15.70	3.75	14.34	3.39
	13	11.8	17.05	3.80	17.05	3.88	17.05	3.97	16.37	3.79	15.70	3.62	14.34	3.27
15	13.7	17.05	3.66	17.05	3.74	17.05	3.82	16.37	3.65	15.70	3.48	14.34	3.15	
120%	-14.7	-15	10.83	3.72	10.83	3.80	10.83	3.88	10.40	3.71	9.97	3.54	9.11	3.20
	-12.6	-13	11.43	3.78	11.43	3.86	11.43	3.94	10.97	3.77	10.52	3.60	9.61	3.25
	-10.5	-11	12.03	3.84	12.03	3.92	12.03	4.01	11.55	3.83	11.08	3.65	10.12	3.30
	-9.5	-10	12.32	3.87	12.32	3.95	12.32	4.04	11.83	3.86	11.34	3.68	10.36	3.33
	-8.5	-9.1	12.60	3.90	12.60	3.98	12.60	4.07	12.10	3.89	11.60	3.71	10.60	3.35
	-7	-7.6	13.03	3.94	13.03	4.03	13.03	4.11	12.52	3.93	12.00	3.75	10.97	3.39
	-5	-5.6	13.61	4.00	13.61	4.09	13.61	4.17	13.07	3.99	12.53	3.81	11.45	3.44
	-3	-3.7	14.18	4.06	14.18	4.15	14.18	4.23	13.62	4.05	13.06	3.86	11.93	3.49
	0	-0.7	15.04	4.15	15.04	4.24	15.04	4.33	14.45	4.14	13.85	3.95	12.65	3.57
	3	2.2	15.90	4.24	15.90	4.33	15.90	4.42	15.27	4.22	14.64	4.03	13.38	3.64
	5	4.1	16.48	4.30	16.48	4.39	16.48	4.48	15.82	4.28	15.17	4.09	13.86	3.69
	7	6	17.05	4.35	17.05	4.45	17.05	4.54	16.37	4.34	15.70	4.14	14.34	3.74
	9	7.9	17.05	4.21	17.05	4.30	17.05	4.39	16.37	4.19	15.70	4.00	14.34	3.62
	11	9.8	17.05	4.06	17.05	4.15	17.05	4.23	16.37	4.05	15.70	3.86	14.34	3.49
	13	11.8	17.05	3.92	17.05	4.00	17.05	4.08	16.37	3.90	15.70	3.72	14.34	3.37
15	13.7	17.05	3.77	17.05	3.85	17.05	3.93	16.37	3.76	15.70	3.59	14.34	3.24	
110%	-14.7	-15	10.83	3.83	10.83	3.91	10.83	3.99	10.40	3.81	9.97	3.64	9.11	3.29
	-12.6	-13	11.43	3.89	11.43	3.97	11.43	4.05	10.97	3.88	10.52	3.70	9.61	3.34
	-10.5	-11	12.03	3.95	12.03	4.04	12.03	4.12	11.55	3.94	11.08	3.76	10.12	3.40
	-9.5	-10	12.32	3.98	12.32	4.07	12.32	4.15	11.83	3.97	11.34	3.79	10.36	3.42
	-8.5	-9.1	12.60	4.01	12.60	4.10	12.60	4.18	12.10	4.00	11.60	3.82	10.60	3.45
	-7	-7.6	13.03	4.06	13.03	4.14	13.03	4.23	12.52	4.04	12.00	3.86	10.97	3.49
	-5	-5.6	13.61	4.12	13.61	4.20	13.61	4.29	13.07	4.10	12.53	3.92	11.45	3.54
	-3	-3.7	14.18	4.18	14.18	4.27	14.18	4.36	13.62	4.16	13.06	3.97	11.93	3.59
	0	-0.7	15.04	4.27	15.04	4.36	15.04	4.45	14.45	4.25	13.85	4.06	12.65	3.67
	3	2.2	15.90	4.36	15.90	4.45	15.90	4.54	15.27	4.34	14.64	4.15	13.38	3.75
	5	4.1	16.48	4.42	16.48	4.51	16.48	4.61	15.82	4.40	15.17	4.20	13.86	3.80
	7	6	17.05	4.48	17.05	4.57	17.05	4.67	16.37	4.46	15.70	4.26	14.34	3.85
	9	7.9	17.05	4.33	17.05	4.42	17.05	4.51	16.37	4.31	15.70	4.12	14.34	3.72
	11	9.8	17.05	4.18	17.05	4.27	17.05	4.36	16.37	4.16	15.70	3.97	14.34	3.59
	13	11.8	17.05	4.03	17.05	4.11	17.05	4.20	16.37	4.01	15.70	3.83	14.34	3.46
15	13.7	17.05	3.88	17.05	3.96	17.05	4.04	16.37	3.86	15.70	3.69	14.34	3.33	
100%	-14.7	-15	9.84	3.38	9.84	3.45	9.84	3.52	9.45	3.37	9.06	3.21	8.28	2.90
	-12.6	-13	10.39	3.43	10.39	3.50	10.39	3.58	9.98	3.42	9.56	3.26	8.74	2.95
	-10.5	-11	10.94	3.49	10.94	3.56	10.94	3.64	10.50	3.48	10.07	3.32	9.20	3.00

	-9.5	-10	11.20	3.51	11.20	3.59	11.20	3.66	10.75	3.50	10.31	3.34	9.42	3.02
	-8.5	-9.1	11.46	3.54	11.46	3.62	11.46	3.69	11.00	3.53	10.55	3.37	9.64	3.04
	-7	-7.6	11.85	3.58	11.85	3.66	11.85	3.73	11.38	3.57	10.91	3.41	9.97	3.08
	-5	-5.6	12.37	3.63	12.37	3.71	12.37	3.79	11.88	3.62	11.39	3.46	10.41	3.12
	-3	-3.7	12.89	3.69	12.89	3.76	12.89	3.84	12.38	3.67	11.87	3.51	10.85	3.17
	0	-0.7	13.67	3.77	13.67	3.85	13.67	3.93	13.13	3.75	12.59	3.58	11.50	3.24
	3	2.2	14.46	3.85	14.46	3.93	14.46	4.01	13.88	3.83	13.31	3.66	12.16	3.31
	5	4.1	14.98	3.90	14.98	3.98	14.98	4.06	14.38	3.89	13.79	3.71	12.60	3.35
	7	6	15.50	3.95	15.50	4.04	15.50	4.12	14.88	3.94	14.27	3.76	13.04	3.40
	9	7.9	15.50	3.82	15.50	3.90	15.50	3.98	14.88	3.81	14.27	3.63	13.04	3.28
	11	9.8	15.50	3.69	15.50	3.76	15.50	3.84	14.88	3.67	14.27	3.51	13.04	3.17
	13	11.8	15.50	3.55	15.50	3.63	15.50	3.70	14.88	3.54	14.27	3.38	13.04	3.06
	15	13.7	15.50	3.42	15.50	3.49	15.50	3.57	14.88	3.41	14.27	3.25	13.04	2.94
90%	-14.7	-15	8.86	2.99	8.86	3.06	8.86	3.12	8.51	2.98	8.15	2.85	7.45	2.57
	-12.6	-13	9.35	3.04	9.35	3.11	9.35	3.17	8.98	3.03	8.61	2.89	7.87	2.62
	-10.5	-11	9.84	3.09	9.84	3.16	9.84	3.22	9.45	3.08	9.06	2.94	8.28	2.66
	-9.5	-10	10.08	3.12	10.08	3.18	10.08	3.25	9.68	3.11	9.28	2.96	8.48	2.68
	-8.5	-9.1	10.31	3.14	10.31	3.21	10.31	3.27	9.90	3.13	9.49	2.99	8.68	2.70
	-7	-7.6	10.66	3.17	10.66	3.24	10.66	3.31	10.24	3.16	9.82	3.02	8.97	2.73
	-5	-5.6	11.13	3.22	11.13	3.29	11.13	3.36	10.69	3.21	10.25	3.06	9.37	2.77
	-3	-3.7	11.60	3.27	11.60	3.34	11.60	3.41	11.14	3.26	10.68	3.11	9.76	2.81
	0	-0.7	12.31	3.34	12.31	3.41	12.31	3.48	11.82	3.33	11.33	3.18	10.35	2.87
	3	2.2	13.01	3.41	13.01	3.48	13.01	3.55	12.49	3.40	11.98	3.24	10.95	2.93
	5	4.1	13.48	3.46	13.48	3.53	13.48	3.60	12.95	3.45	12.41	3.29	11.34	2.97
	7	6	13.95	3.50	13.95	3.58	13.95	3.65	13.40	3.49	12.84	3.33	11.74	3.01
	9	7.9	13.95	3.39	13.95	3.46	13.95	3.53	13.40	3.38	12.84	3.22	11.74	2.91
	11	9.8	13.95	3.27	13.95	3.34	13.95	3.41	13.40	3.26	12.84	3.11	11.74	2.81
	13	11.8	13.95	3.15	13.95	3.22	13.95	3.29	13.40	3.14	12.84	3.00	11.74	2.71
15	13.7	13.95	3.03	13.95	3.10	13.95	3.16	13.40	3.02	12.84	2.89	11.74	2.61	
80%	-14.7	-15	7.87	2.63	7.87	2.68	7.87	2.74	7.56	2.62	7.25	2.50	6.62	2.26
	-12.6	-13	8.31	2.67	8.31	2.73	8.31	2.79	7.98	2.66	7.65	2.54	6.99	2.30
	-10.5	-11	8.75	2.71	8.75	2.77	8.75	2.83	8.40	2.71	8.05	2.58	7.36	2.33
	-9.5	-10	8.96	2.74	8.96	2.79	8.96	2.85	8.60	2.73	8.25	2.60	7.54	2.35
	-8.5	-9.1	9.17	2.76	9.17	2.81	9.17	2.87	8.80	2.75	8.44	2.62	7.71	2.37
	-7	-7.6	9.48	2.79	9.48	2.85	9.48	2.91	9.10	2.78	8.73	2.65	7.97	2.40
	-5	-5.6	9.90	2.83	9.90	2.89	9.90	2.95	9.50	2.82	9.11	2.69	8.33	2.43
	-3	-3.7	10.31	2.87	10.31	2.93	10.31	2.99	9.90	2.86	9.50	2.73	8.68	2.47
	0	-0.7	10.94	2.93	10.94	2.99	10.94	3.06	10.51	2.92	10.07	2.79	9.20	2.52
	3	2.2	11.57	2.99	11.57	3.06	11.57	3.12	11.11	2.98	10.65	2.85	9.73	2.57
	5	4.1	11.98	3.04	11.98	3.10	11.98	3.16	11.51	3.03	11.03	2.89	10.08	2.61
	7	6	12.40	3.08	12.40	3.14	12.40	3.21	11.91	3.07	11.42	2.93	10.43	2.65
	9	7.9	12.40	2.97	12.40	3.04	12.40	3.10	11.91	2.96	11.42	2.83	10.43	2.56
	11	9.8	12.40	2.87	12.40	2.93	12.40	2.99	11.91	2.86	11.42	2.73	10.43	2.47
	13	11.8	12.40	2.77	12.40	2.83	12.40	2.88	11.91	2.76	11.42	2.63	10.43	2.38
15	13.7	12.40	2.66	12.40	2.72	12.40	2.78	11.91	2.66	11.42	2.53	10.43	2.29	
70%	-14.7	-15	6.89	2.26	6.89	2.31	6.89	2.36	6.62	2.26	6.34	2.15	5.80	1.95
	-12.6	-13	7.27	2.30	7.27	2.35	7.27	2.40	6.98	2.29	6.70	2.19	6.12	1.98
	-10.5	-11	7.66	2.34	7.66	2.39	7.66	2.44	7.35	2.33	7.05	2.22	6.44	2.01
	-9.5	-10	7.84	2.36	7.84	2.41	7.84	2.46	7.53	2.35	7.22	2.24	6.59	2.03
	-8.5	-9.1	8.02	2.37	8.02	2.42	8.02	2.47	7.70	2.37	7.38	2.26	6.75	2.04
	-7	-7.6	8.29	2.40	8.29	2.45	8.29	2.50	7.97	2.39	7.64	2.28	6.98	2.06
	-5	-5.6	8.66	2.44	8.66	2.49	8.66	2.54	8.32	2.43	7.97	2.32	7.29	2.09
	-3	-3.7	9.02	2.47	9.02	2.52	9.02	2.58	8.67	2.46	8.31	2.35	7.59	2.13
	0	-0.7	9.57	2.52	9.57	2.58	9.57	2.63	9.19	2.52	8.81	2.40	8.05	2.17
	3	2.2	10.12	2.58	10.12	2.63	10.12	2.69	9.72	2.57	9.32	2.45	8.51	2.22
	5	4.1	10.48	2.61	10.48	2.67	10.48	2.73	10.07	2.61	9.65	2.49	8.82	2.25
	7	6	10.85	2.65	10.85	2.71	10.85	2.76	10.42	2.64	9.99	2.52	9.13	2.28
9	7.9	10.85	2.56	10.85	2.62	10.85	2.67	10.42	2.55	9.99	2.44	9.13	2.20	

	11	9.8	10.85	2.47	10.85	2.52	10.85	2.58	10.42	2.46	9.99	2.35	9.13	2.13
	13	11.8	10.85	2.38	10.85	2.43	10.85	2.48	10.42	2.38	9.99	2.27	9.13	2.05
	15	13.7	10.85	2.29	10.85	2.34	10.85	2.39	10.42	2.29	9.99	2.18	9.13	1.97
60%	-14.7	-15	5.90	1.90	5.90	1.94	5.90	1.98	5.67	1.89	5.44	1.81	4.97	1.63
	-12.6	-13	6.23	1.93	6.23	1.97	6.23	2.01	5.99	1.92	5.74	1.84	5.24	1.66
	-10.5	-11	6.56	1.96	6.56	2.00	6.56	2.04	6.30	1.96	6.04	1.87	5.52	1.69
	-9.5	-10	6.72	1.98	6.72	2.02	6.72	2.06	6.45	1.97	6.19	1.88	5.65	1.70
	-8.5	-9.1	6.87	1.99	6.87	2.03	6.87	2.08	6.60	1.98	6.33	1.89	5.78	1.71
	-7	-7.6	7.11	2.01	7.11	2.06	7.11	2.10	6.83	2.01	6.55	1.92	5.98	1.73
	-5	-5.6	7.42	2.04	7.42	2.09	7.42	2.13	7.13	2.04	6.83	1.94	6.24	1.76
	-3	-3.7	7.74	2.07	7.74	2.12	7.74	2.16	7.43	2.07	7.12	1.97	6.51	1.78
	0	-0.7	8.20	2.12	8.20	2.16	8.20	2.21	7.88	2.11	7.55	2.01	6.90	1.82
	3	2.2	8.67	2.16	8.67	2.21	8.67	2.25	8.33	2.16	7.99	2.06	7.30	1.86
	5	4.1	8.99	2.19	8.99	2.24	8.99	2.29	8.63	2.19	8.27	2.09	7.56	1.89
	7	6	9.30	2.22	9.30	2.27	9.30	2.32	8.93	2.22	8.56	2.11	7.82	1.91
	9	7.9	9.30	2.15	9.30	2.19	9.30	2.24	8.93	2.14	8.56	2.04	7.82	1.85
	11	9.8	9.30	2.07	9.30	2.12	9.30	2.16	8.93	2.07	8.56	1.97	7.82	1.78
	13	11.8	9.30	2.00	9.30	2.04	9.30	2.08	8.93	1.99	8.56	1.90	7.82	1.72
15	13.7	9.30	1.92	9.30	1.96	9.30	2.01	8.93	1.92	8.56	1.83	7.82	1.65	
50%	-14.7	-15	4.92	1.53	4.92	1.57	4.92	1.60	4.73	1.53	4.53	1.46	4.14	1.32
	-12.6	-13	5.19	1.56	5.19	1.59	5.19	1.63	4.99	1.55	4.78	1.48	4.37	1.34
	-10.5	-11	5.47	1.58	5.47	1.62	5.47	1.65	5.25	1.58	5.03	1.51	4.60	1.36
	-9.5	-10	5.60	1.60	5.60	1.63	5.60	1.66	5.38	1.59	5.15	1.52	4.71	1.37
	-8.5	-9.1	5.73	1.61	5.73	1.64	5.73	1.68	5.50	1.60	5.27	1.53	4.82	1.38
	-7	-7.6	5.92	1.63	5.92	1.66	5.92	1.70	5.69	1.62	5.45	1.55	4.98	1.40
	-5	-5.6	6.19	1.65	6.19	1.69	6.19	1.72	5.94	1.65	5.69	1.57	5.20	1.42
	-3	-3.7	6.45	1.67	6.45	1.71	6.45	1.75	6.19	1.67	5.93	1.59	5.42	1.44
	0	-0.7	6.84	1.71	6.84	1.75	6.84	1.78	6.57	1.71	6.29	1.63	5.75	1.47
	3	2.2	7.23	1.75	7.23	1.78	7.23	1.82	6.94	1.74	6.65	1.66	6.08	1.50
	5	4.1	7.49	1.77	7.49	1.81	7.49	1.85	7.19	1.77	6.89	1.68	6.30	1.52
	7	6	7.75	1.80	7.75	1.83	7.75	1.87	7.44	1.79	7.13	1.71	6.52	1.54
	9	7.9	7.75	1.73	7.75	1.77	7.75	1.81	7.44	1.73	7.13	1.65	6.52	1.49
	11	9.8	7.75	1.67	7.75	1.71	7.75	1.75	7.44	1.67	7.13	1.59	6.52	1.44
	13	11.8	7.75	1.61	7.75	1.65	7.75	1.68	7.44	1.61	7.13	1.54	6.52	1.39
15	13.7	7.75	1.55	7.75	1.59	7.75	1.62	7.44	1.55	7.13	1.48	6.52	1.34	

MDV-V160W/BDRN1-B

Cooling

Combination (Capacity index)	Outdoor temperature (°C DB)	Indoor temperature(°C WB)													
		14.00		16.00		18.00		19.00		20.00		22.00		24.00	
		TC	PI	TC	PI	TC	PI	TC	PI	TC	PI	TC	PI	TC	PI
		kW	kW	kW	kW	kW	kW	kW	kW	kW	kW	kW	kW	kW	kW
130%	10.00	13.62	2.12	16.22	2.59	18.82	3.08	19.54	3.15	19.76	3.09	20.26	2.96	20.76	2.82
	12.00	13.62	2.16	16.22	2.64	18.82	3.14	19.26	3.13	19.54	3.07	19.98	2.93	20.48	2.89
	14.00	13.62	2.20	16.22	2.69	18.77	3.18	19.04	3.14	19.26	3.05	19.76	3.03	20.26	3.06
	16.00	13.62	2.24	16.22	2.75	18.54	3.17	18.77	3.12	18.99	3.16	19.49	3.19	19.98	3.22
	18.00	13.62	2.28	16.22	2.80	18.27	3.29	18.49	3.30	18.77	3.32	19.26	3.35	19.76	3.39
	19.00	13.62	2.33	16.22	2.98	17.99	3.45	18.27	3.47	18.49	3.48	18.99	3.52	19.49	3.55
	21.00	13.62	2.39	16.22	3.09	17.88	3.53	18.16	3.55	18.38	3.57	18.88	3.60	19.37	3.63
	23.00	13.62	2.57	16.22	3.31	17.66	3.69	17.88	3.71	18.10	3.73	18.60	3.76	19.10	3.80
	25.00	13.62	2.74	16.22	3.55	17.38	3.85	17.60	3.87	17.88	3.89	18.38	3.93	18.88	3.97
	27.00	13.62	2.93	16.22	3.79	17.16	4.01	17.38	4.04	17.60	4.05	18.10	4.10	18.60	4.14
	29.00	13.62	3.12	16.22	4.05	16.88	4.17	17.10	4.20	17.38	4.22	17.88	4.27	18.38	4.31
	31.00	13.62	3.34	16.16	4.29	16.61	4.34	16.88	4.36	17.10	4.38	17.60	4.43	18.10	4.48
	33.00	13.62	3.55	15.89	4.45	16.39	4.50	16.61	4.53	16.88	4.55	17.38	4.60	17.82	4.65
	35.00	13.62	3.79	15.61	4.61	16.11	4.67	16.39	4.69	16.61	4.72	17.10	4.77	17.60	4.82
	37.00	13.62	4.03	15.39	4.78	15.89	4.84	16.11	4.86	16.39	4.89	16.83	4.95	17.33	5.00
	39.00	13.62	4.29	15.11	4.83	15.61	5.00	15.89	5.03	16.11	5.06	16.61	5.11	17.10	5.18
41.00	13.62	4.52	14.96	4.88	15.45	5.04	15.72	5.07	15.94	5.11	16.44	5.13	16.45	5.22	
43.00	13.62	4.63	14.85	4.90	15.36	5.06	15.64	5.10	15.78	5.11	16.14	5.13	16.25	5.24	
120%	10.00	12.57	1.93	14.95	2.36	17.38	2.81	18.60	3.04	19.49	3.17	19.93	3.04	20.37	2.93
	12.00	12.57	1.97	14.95	2.41	17.38	2.86	18.60	3.09	19.21	3.15	19.65	3.03	20.09	2.91
	14.00	12.57	2.01	14.95	2.46	17.38	2.92	18.60	3.16	18.93	3.13	19.43	3.01	19.87	3.03
	16.00	12.57	2.05	14.95	2.50	17.38	2.98	18.49	3.18	18.71	3.14	19.15	3.17	19.60	3.19
	18.00	12.57	2.08	14.95	2.55	17.38	3.08	18.21	3.29	18.43	3.30	18.88	3.33	19.37	3.36
	19.00	12.57	2.13	14.95	2.65	17.38	3.31	17.99	3.45	18.21	3.46	18.66	3.49	19.10	3.52
	21.00	12.57	2.15	14.95	2.75	17.38	3.43	17.82	3.53	18.05	3.54	18.54	3.57	18.99	3.61
	23.00	12.57	2.29	14.95	2.94	17.38	3.67	17.60	3.68	17.82	3.70	18.27	3.74	18.71	3.77
	25.00	12.57	2.45	14.95	3.15	17.10	3.83	17.33	3.84	17.55	3.86	18.05	3.90	18.49	3.94
	27.00	12.57	2.62	14.95	3.37	16.88	3.99	17.10	4.01	17.33	4.03	17.77	4.07	18.21	4.10
	29.00	12.57	2.79	14.95	3.60	16.61	4.15	16.83	4.17	17.05	4.19	17.49	4.23	17.99	4.27
	31.00	12.57	2.98	14.95	3.84	16.33	4.31	16.61	4.33	16.83	4.36	17.27	4.40	17.71	4.45
	33.00	12.57	3.17	14.95	4.09	16.11	4.48	16.33	4.50	16.55	4.52	16.99	4.57	17.44	4.61
	35.00	12.57	3.37	14.95	4.36	15.83	4.64	16.05	4.66	16.33	4.69	16.77	4.74	17.22	4.79
	37.00	12.57	3.59	14.95	4.65	15.61	4.80	15.83	4.83	16.05	4.85	16.50	4.90	16.94	4.96
	39.00	12.57	3.82	14.89	4.91	15.33	4.97	15.56	5.00	15.78	5.02	16.27	5.08	16.72	5.13
41.00	12.57	3.92	14.77	4.95	15.21	5.00	15.44	5.03	15.66	5.06	16.15	5.09	16.24	5.17	
43.00	12.57	3.98	14.69	4.98	15.09	5.03	15.31	5.05	15.54	5.07	15.87	5.11	15.98	5.27	
110%	10.00	11.51	1.75	13.73	2.14	15.94	2.54	17.05	2.75	18.16	2.96	19.54	3.14	19.99	3.03
	12.00	11.51	1.79	13.73	2.18	15.94	2.59	17.05	2.80	18.16	3.01	19.32	3.12	19.71	3.01
	14.00	11.51	1.82	13.73	2.22	15.94	2.64	17.05	2.85	18.16	3.07	19.04	3.11	19.49	3.01
	16.00	11.51	1.85	13.73	2.26	15.94	2.69	17.05	2.91	18.16	3.13	18.82	3.14	19.21	3.17
	18.00	11.51	1.89	13.73	2.31	15.94	2.75	17.05	2.99	18.16	3.28	18.54	3.30	18.99	3.34
	19.00	11.51	1.93	13.73	2.36	15.94	2.91	17.05	3.21	17.88	3.44	18.32	3.47	18.71	3.50
	21.00	11.51	1.95	13.73	2.42	15.94	3.01	17.05	3.33	17.77	3.52	18.16	3.55	18.60	3.58
	23.00	11.51	2.04	13.73	2.60	15.94	3.23	17.05	3.57	17.49	3.68	17.94	3.71	18.32	3.74
	25.00	11.51	2.18	13.73	2.78	15.94	3.45	17.05	3.83	17.27	3.84	17.66	3.87	18.10	3.91
	27.00	11.51	2.32	13.73	2.97	15.94	3.70	16.77	3.99	17.00	4.00	17.44	4.04	17.83	4.07
	29.00	11.51	2.47	13.73	3.17	15.94	3.95	16.55	4.15	16.77	4.17	17.16	4.20	17.60	4.24
	31.00	11.51	2.63	13.73	3.38	15.94	4.22	16.28	4.31	16.50	4.33	16.94	4.36	17.33	4.41
33.00	11.51	2.80	13.73	3.60	15.83	4.45	16.05	4.47	16.28	4.49	16.66	4.53	17.11	4.58	
35.00	11.51	2.98	13.73	3.84	15.56	4.61	15.78	4.63	16.00	4.66	16.39	4.70	16.83	4.74	

	37.00	11.51	3.17	13.73	4.09	15.33	4.77	15.56	4.79	15.72	4.82	16.17	4.87	16.55	4.91
	39.00	11.51	3.37	13.73	4.35	15.06	4.94	15.28	4.96	15.50	4.98	15.89	5.03	16.33	5.08
	41.00	11.51	3.41	13.73	4.39	14.94	4.97	15.16	4.99	15.38	5.02	15.69	5.07	15.84	5.12
	43.00	11.51	3.44	13.73	4.44	14.82	5.00	15.04	5.03	15.26	5.05	15.55	5.09	15.60	5.22
100%	10.00	10.46	1.59	12.46	1.92	14.50	2.28	15.50	2.46	16.50	2.65	18.54	3.03	19.60	3.13
	12.00	10.46	1.61	12.46	1.96	14.50	2.32	15.50	2.50	16.50	2.70	18.54	3.08	19.32	3.11
	14.00	10.46	1.64	12.46	2.00	14.50	2.36	15.50	2.55	16.50	2.75	18.54	3.14	19.10	3.09
	16.00	10.46	1.67	12.46	2.03	14.50	2.41	15.50	2.60	16.50	2.80	18.43	3.18	18.82	3.15
	18.00	10.46	1.70	12.46	2.07	14.50	2.46	15.50	2.65	16.50	2.86	18.21	3.29	18.60	3.31
	19.00	10.46	1.74	12.46	2.11	14.50	2.53	15.50	2.79	16.50	3.06	17.94	3.44	18.32	3.47
	21.00	10.46	1.75	12.46	2.13	14.50	2.62	15.50	2.89	16.50	3.17	17.83	3.52	18.21	3.55
	23.00	10.46	1.80	12.46	2.28	14.50	2.81	15.50	3.09	16.50	3.40	17.60	3.68	17.94	3.71
	25.00	10.46	1.92	12.46	2.43	14.50	3.01	15.50	3.32	16.50	3.64	17.33	3.84	17.71	3.87
	27.00	10.46	2.05	12.46	2.59	14.50	3.21	15.50	3.55	16.50	3.89	17.05	4.00	17.44	4.04
	29.00	10.46	2.18	12.46	2.77	14.50	3.43	15.50	3.79	16.44	4.13	16.83	4.17	17.22	4.20
	31.00	10.46	2.32	12.46	2.95	14.50	3.66	15.50	4.04	16.22	4.30	16.55	4.33	16.94	4.37
	33.00	10.46	2.46	12.46	3.14	14.50	3.90	15.50	4.31	15.94	4.46	16.33	4.49	16.72	4.54
	35.00	10.46	2.62	12.46	3.34	14.50	4.16	15.50	4.60	15.67	4.62	16.05	4.66	16.44	4.70
	37.00	10.46	2.78	12.46	3.56	14.50	4.43	15.22	4.76	15.44	4.79	15.83	4.83	16.16	4.87
	39.00	10.46	2.96	12.46	3.78	14.50	4.72	15.00	4.92	15.17	4.95	15.56	4.99	15.94	5.04
	41.00	10.46	3.09	12.46	3.92	14.50	4.89	14.77	4.96	15.05	5.02	15.29	5.11	15.71	5.14
	43.00	10.46	3.23	12.46	4.06	14.50	4.98	14.54	5.01	14.94	5.07	15.38	5.14	15.43	5.20
	90%	10.00	9.41	1.42	11.24	1.71	13.06	2.02	13.95	2.18	14.84	2.34	16.66	2.68	18.49
12.00		9.41	1.44	11.24	1.74	13.06	2.06	13.95	2.22	14.84	2.39	16.66	2.73	18.49	3.07
14.00		9.41	1.47	11.24	1.77	13.06	2.10	13.95	2.26	14.84	2.43	16.66	2.78	18.49	3.13
16.00		9.41	1.49	11.24	1.80	13.06	2.14	13.95	2.31	14.84	2.48	16.66	2.83	18.43	3.19
18.00		9.41	1.52	11.24	1.84	13.06	2.18	13.95	2.35	14.84	2.53	16.66	2.89	18.21	3.29
19.00		9.41	1.55	11.24	1.88	13.06	2.22	13.95	2.40	14.84	2.62	16.66	3.11	17.94	3.44
21.00		9.41	1.56	11.24	1.90	13.06	2.26	13.95	2.48	14.84	2.72	16.66	3.22	17.83	3.52
23.00		9.41	1.59	11.24	1.97	13.06	2.42	13.95	2.66	14.84	2.91	16.66	3.45	17.55	3.68
25.00		9.41	1.68	11.24	2.11	13.06	2.58	13.95	2.85	14.84	3.11	16.66	3.69	17.33	3.84
27.00		9.41	1.79	11.24	2.24	13.06	2.76	13.95	3.04	14.84	3.33	16.66	3.96	17.05	4.00
29.00		9.41	1.90	11.24	2.39	13.06	2.94	13.95	3.24	14.84	3.56	16.50	4.14	16.83	4.17
31.00		9.41	2.02	11.24	2.55	13.06	3.14	13.95	3.46	14.84	3.79	16.22	4.30	16.55	4.33
33.00		9.41	2.14	11.24	2.71	13.06	3.35	13.95	3.69	14.84	4.05	16.00	4.46	16.33	4.49
35.00		9.41	2.28	11.24	2.88	13.06	3.56	13.95	3.93	14.84	4.31	15.72	4.62	16.05	4.66
37.00		9.41	2.42	11.24	3.06	13.06	3.79	13.95	4.18	14.84	4.60	15.44	4.79	15.83	4.82
39.00	9.41	2.57	11.24	3.26	13.06	4.04	13.95	4.46	14.84	4.90	15.22	4.95	15.56	4.99	
41.00	9.41	2.65	11.24	3.41	13.06	4.18	13.95	4.58	14.84	4.93	15.12	5.08	15.45	5.11	
43.00	9.41	2.78	11.24	3.56	13.06	4.33	13.95	4.69	14.84	5.03	15.04	5.15	15.32	5.19	
80%	10.00	8.36	1.26	9.96	1.51	11.57	1.77	12.40	1.91	13.23	2.05	14.84	2.34	16.44	2.63
	12.00	8.36	1.28	9.96	1.53	11.57	1.80	12.40	1.95	13.23	2.09	14.84	2.38	16.44	2.68
	14.00	8.36	1.30	9.96	1.56	11.57	1.84	12.40	1.98	13.23	2.13	14.84	2.42	16.44	2.73
	16.00	8.36	1.32	9.96	1.59	11.57	1.87	12.40	2.01	13.23	2.16	14.84	2.47	16.44	2.78
	18.00	8.36	1.35	9.96	1.62	11.57	1.91	12.40	2.06	13.23	2.21	14.84	2.52	16.44	2.84
	19.00	8.36	1.37	9.96	1.65	11.57	1.95	12.40	2.10	13.23	2.25	14.84	2.62	16.44	3.04
	21.00	8.36	1.38	9.96	1.66	11.57	1.97	12.40	2.12	13.23	2.30	14.84	2.71	16.44	3.15
	23.00	8.36	1.41	9.96	1.70	11.57	2.06	12.40	2.26	13.23	2.46	14.84	2.90	16.44	3.38
	25.00	8.36	1.45	9.96	1.80	11.57	2.20	12.40	2.41	13.23	2.63	14.84	3.11	16.44	3.61
	27.00	8.36	1.54	9.96	1.92	11.57	2.34	12.40	2.57	13.23	2.81	14.84	3.32	16.44	3.87
	29.00	8.36	1.64	9.96	2.05	11.57	2.50	12.40	2.74	13.23	3.00	14.84	3.54	16.44	4.14
	31.00	8.36	1.74	9.96	2.18	11.57	2.66	12.40	2.92	13.23	3.20	14.84	3.78	16.16	4.30
	33.00	8.36	1.85	9.96	2.31	11.57	2.83	12.40	3.11	13.23	3.40	14.84	4.03	15.94	4.46
	35.00	8.36	1.97	9.96	2.46	11.57	3.01	12.40	3.31	13.23	3.63	14.84	4.30	15.67	4.62
	37.00	8.36	2.08	9.96	2.61	11.57	3.21	12.40	3.53	13.23	3.86	14.84	4.58	15.44	4.78
39.00	8.36	2.21	9.96	2.78	11.57	3.41	12.40	3.75	13.23	4.11	14.84	4.88	15.17	4.95	
41.00	8.36	2.26	9.96	2.81	11.57	3.46	12.40	3.85	13.23	4.18	14.84	5.00	15.07	5.03	
43.00	8.36	2.32	9.96	2.83	11.57	3.51	12.40	3.92	13.23	4.24	14.84	5.06	14.98	5.09	

70%	10.00	7.31	1.11	8.75	1.31	10.13	1.53	10.85	1.65	11.57	1.77	12.95	2.01	14.39	2.26
	12.00	7.31	1.12	8.75	1.33	10.13	1.56	10.85	1.68	11.57	1.80	12.95	2.05	14.39	2.30
	14.00	7.31	1.14	8.75	1.36	10.13	1.59	10.85	1.70	11.57	1.83	12.95	2.08	14.39	2.34
	16.00	7.31	1.16	8.75	1.38	10.13	1.62	10.85	1.74	11.57	1.87	12.95	2.12	14.39	2.39
	18.00	7.31	1.18	8.75	1.41	10.13	1.65	10.85	1.77	11.57	1.90	12.95	2.16	14.39	2.44
	19.00	7.31	1.20	8.75	1.43	10.13	1.68	10.85	1.80	11.57	1.93	12.95	2.21	14.39	2.50
	21.00	7.31	1.21	8.75	1.44	10.13	1.69	10.85	1.82	11.57	1.95	12.95	2.24	14.39	2.59
	23.00	7.31	1.23	8.75	1.47	10.13	1.73	10.85	1.88	11.57	2.05	12.95	2.40	14.39	2.78
	25.00	7.31	1.25	8.75	1.53	10.13	1.84	10.85	2.01	11.57	2.19	12.95	2.57	14.39	2.97
	27.00	7.31	1.33	8.75	1.63	10.13	1.97	10.85	2.15	11.57	2.34	12.95	2.74	14.39	3.17
	29.00	7.31	1.41	8.75	1.73	10.13	2.09	10.85	2.29	11.57	2.49	12.95	2.92	14.39	3.39
	31.00	7.31	1.49	8.75	1.84	10.13	2.23	10.85	2.43	11.57	2.65	12.95	3.11	14.39	3.61
	33.00	7.31	1.58	8.75	1.95	10.13	2.37	10.85	2.59	11.57	2.82	12.95	3.32	14.39	3.86
	35.00	7.31	1.67	8.75	2.07	10.13	2.51	10.85	2.75	11.57	3.00	12.95	3.53	14.39	4.11
	37.00	7.31	1.77	8.75	2.19	10.13	2.67	10.85	2.92	11.57	3.19	12.95	3.76	14.39	4.38
	39.00	7.31	1.87	8.75	2.32	10.13	2.83	10.85	3.11	11.57	3.39	12.95	4.00	14.39	4.66
41.00	7.31	1.95	8.75	2.41	10.13	2.92	10.85	3.21	11.57	3.49	12.95	4.16	14.39	4.87	
43.00	7.31	2.11	8.75	2.57	10.13	3.04	10.85	3.38	11.57	3.60	12.95	4.32	14.39	5.02	
60%	10.00	6.26	0.96	7.47	1.13	8.69	1.31	9.30	1.40	9.91	1.49	11.13	1.69	12.34	1.90
	12.00	6.26	0.98	7.47	1.15	8.69	1.33	9.30	1.43	9.91	1.52	11.13	1.72	12.34	1.93
	14.00	6.26	0.99	7.47	1.17	8.69	1.35	9.30	1.45	9.91	1.55	11.13	1.75	12.34	1.96
	16.00	6.26	1.00	7.47	1.18	8.69	1.38	9.30	1.48	9.91	1.57	11.13	1.79	12.34	2.00
	18.00	6.26	1.02	7.47	1.20	8.69	1.40	9.30	1.50	9.91	1.61	11.13	1.82	12.34	2.04
	19.00	6.26	1.04	7.47	1.23	8.69	1.43	9.30	1.53	9.91	1.64	11.13	1.85	12.34	2.08
	21.00	6.26	1.05	7.47	1.23	8.69	1.44	9.30	1.54	9.91	1.65	11.13	1.87	12.34	2.10
	23.00	6.26	1.06	7.47	1.26	8.69	1.46	9.30	1.57	9.91	1.68	11.13	1.95	12.34	2.24
	25.00	6.26	1.08	7.47	1.28	8.69	1.52	9.30	1.65	9.91	1.79	11.13	2.08	12.34	2.39
	27.00	6.26	1.12	7.47	1.36	8.69	1.62	9.30	1.76	9.91	1.90	11.13	2.21	12.34	2.55
	29.00	6.26	1.18	7.47	1.44	8.69	1.72	9.30	1.87	9.91	2.03	11.13	2.36	12.34	2.72
	31.00	6.26	1.26	7.47	1.52	8.69	1.83	9.30	1.99	9.91	2.16	11.13	2.51	12.34	2.89
	33.00	6.26	1.33	7.47	1.62	8.69	1.94	9.30	2.11	9.91	2.29	11.13	2.67	12.34	3.09
	35.00	6.26	1.41	7.47	1.72	8.69	2.06	9.30	2.24	9.91	2.44	11.13	2.85	12.34	3.29
	37.00	6.26	1.49	7.47	1.82	8.69	2.18	9.30	2.38	9.91	2.58	11.13	3.02	12.34	3.50
	39.00	6.26	1.57	7.47	1.92	8.69	2.31	9.30	2.52	9.91	2.75	11.13	3.21	12.34	3.72
41.00	6.26	1.62	7.47	2.00	8.69	2.40	9.30	2.62	9.91	2.85	11.13	3.36	12.34	3.89	
43.00	6.26	1.67	7.47	2.09	8.69	2.48	9.30	2.70	9.91	2.95	11.13	3.50	12.34	4.06	
50%	10.00	5.23	0.83	6.26	0.96	7.25	1.10	7.75	1.17	8.25	1.24	9.24	1.39	10.30	1.56
	12.00	5.23	0.84	6.26	0.97	7.25	1.12	7.75	1.18	8.25	1.26	9.24	1.42	10.30	1.58
	14.00	5.23	0.85	6.26	0.99	7.25	1.13	7.75	1.21	8.25	1.28	9.24	1.44	10.30	1.61
	16.00	5.23	0.86	6.26	1.00	7.25	1.15	7.75	1.23	8.25	1.30	9.24	1.47	10.30	1.64
	18.00	5.23	0.87	6.26	1.02	7.25	1.17	7.75	1.25	8.25	1.33	9.24	1.49	10.30	1.67
	19.00	5.23	0.89	6.26	1.03	7.25	1.18	7.75	1.26	8.25	1.35	9.24	1.52	10.30	1.70
	21.00	5.23	0.89	6.26	1.04	7.25	1.20	7.75	1.28	8.25	1.36	9.24	1.54	10.30	1.72
	23.00	5.23	0.90	6.26	1.05	7.25	1.22	7.75	1.30	8.25	1.39	9.24	1.56	10.30	1.75
	25.00	5.23	0.92	6.26	1.07	7.25	1.24	7.75	1.33	8.25	1.43	9.24	1.64	10.30	1.87
	27.00	5.23	0.94	6.26	1.12	7.25	1.31	7.75	1.41	8.25	1.52	9.24	1.75	10.30	2.00
	29.00	5.23	0.99	6.26	1.18	7.25	1.39	7.75	1.50	8.25	1.62	9.24	1.86	10.30	2.13
	31.00	5.23	1.04	6.26	1.25	7.25	1.47	7.75	1.59	8.25	1.72	9.24	1.98	10.30	2.26
	33.00	5.23	1.10	6.26	1.32	7.25	1.56	7.75	1.69	8.25	1.82	9.24	2.10	10.30	2.41
	35.00	5.23	1.17	6.26	1.39	7.25	1.65	7.75	1.79	8.25	1.93	9.24	2.23	10.30	2.55
	37.00	5.23	1.23	6.26	1.48	7.25	1.75	7.75	1.89	8.25	2.05	9.24	2.37	10.30	2.72
	39.00	5.23	1.30	6.26	1.56	7.25	1.85	7.75	2.00	8.25	2.17	9.24	2.51	10.30	2.88
41.00	5.23	1.35	6.26	1.62	7.25	1.91	7.75	2.10	8.25	2.26	9.24	2.64	10.30	3.02	
43.00	5.23	1.44	6.26	1.73	7.25	1.98	7.75	2.19	8.25	2.32	9.24	2.78	10.30	3.15	

Heating

Combination (Capacity index)	Outdoor air temp.		Indoor temperature(°C DB)											
			16		18		20		21		22		24	
	°C DB	°C WB	TC	PI	TC	PI	TC	PI	TC	PI	TC	PI	TC	PI
			kW	kW	kW	kW	kW	kW	kW	kW	kW	kW	kW	kW
130%	-14.7	-15	12.44	3.82	12.39	4.04	12.33	4.26	12.33	4.37	12.28	4.48	12.28	4.70
	-12.6	-13	12.94	3.99	12.94	4.20	12.89	4.41	12.83	4.52	12.83	4.62	12.78	4.83
	-10.5	-11	13.56	4.17	13.50	4.37	13.44	4.57	13.44	4.67	13.44	4.77	13.39	4.97
	-9.5	-10	13.89	4.25	13.83	4.45	13.78	4.64	13.78	4.74	13.72	4.84	13.72	5.03
	-8.5	-9.1	14.17	4.33	14.11	4.52	14.11	4.71	14.06	4.80	14.06	4.90	14.00	5.09
	-7	-7.6	14.67	4.45	14.67	4.64	14.61	4.82	14.61	4.92	14.55	5.01	14.50	5.19
	-5	-5.6	15.44	4.62	15.39	4.80	15.33	4.97	15.33	5.06	15.28	5.14	15.28	5.32
	-3	-3.7	16.17	4.77	16.11	4.94	16.11	5.11	16.06	5.19	16.06	5.28	16.00	5.44
	0	-0.7	17.44	5.01	17.44	5.16	17.39	5.31	17.39	5.37	17.33	5.47	17.33	5.62
	3	2.2	18.83	5.21	18.78	5.36	18.72	5.50	18.72	5.57	18.72	5.65	18.67	5.78
	5	4.1	19.78	5.34	19.72	5.48	19.72	5.61	19.67	5.68	19.67	5.75	19.61	5.88
	7	6	20.78	5.47	20.72	5.60	20.72	5.73	20.67	5.79	20.67	5.85	19.83	5.62
	9	7.9	21.83	5.58	21.78	5.71	21.78	5.83	21.72	5.89	21.28	5.77	19.83	5.28
	11	9.8	22.94	5.70	22.89	5.81	22.78	5.88	22.00	5.65	21.28	5.42	19.83	4.97
	13	11.8	24.17	5.80	24.11	5.92	22.78	5.51	22.00	5.29	21.28	5.09	19.83	4.67
15	13.7	25.33	5.90	24.22	5.60	22.78	5.19	22.00	4.99	21.28	4.79	19.83	4.40	
120%	-14.7	-15	12.39	4.11	12.33	4.32	12.28	4.52	12.28	4.62	12.28	4.72	12.22	4.92
	-12.6	-13	12.89	4.27	12.89	4.47	12.83	4.66	12.83	4.76	12.78	4.85	12.78	5.05
	-10.5	-11	13.50	4.43	13.44	4.62	13.44	4.80	13.39	4.90	13.39	4.99	13.33	5.18
	-9.5	-10	13.83	4.52	13.78	4.70	13.72	4.87	13.72	4.97	13.72	5.06	13.67	5.24
	-8.5	-9.1	14.11	4.59	14.06	4.76	14.06	4.94	14.00	5.02	14.00	5.12	13.94	5.29
	-7	-7.6	14.61	4.70	14.61	4.87	14.56	5.04	14.56	5.13	14.50	5.21	14.50	5.38
	-5	-5.6	15.39	4.85	15.33	5.02	15.28	5.18	15.28	5.26	15.28	5.34	15.22	5.50
	-3	-3.7	16.11	5.00	16.11	5.16	16.06	5.31	16.06	5.38	16.00	5.46	16.00	5.61
	0	-0.7	17.39	5.21	17.39	5.36	17.33	5.49	17.33	5.57	17.28	5.64	17.28	5.78
	3	2.2	18.78	5.41	18.72	5.54	18.72	5.67	18.67	5.74	18.67	5.80	18.28	5.77
	5	4.1	19.72	5.53	19.67	5.65	19.67	5.78	19.61	5.84	19.61	5.90	18.28	5.42
	7	6	20.72	5.64	20.72	5.76	20.67	5.88	20.33	5.80	19.67	5.56	18.28	5.10
	9	7.9	21.78	5.75	21.72	5.87	21.00	5.67	20.33	5.45	19.67	5.23	18.28	4.80
	11	9.8	22.89	5.85	22.33	5.75	21.00	5.33	20.33	5.12	19.67	4.92	18.28	4.52
	13	11.8	23.72	5.80	22.33	5.39	21.00	5.00	20.33	4.81	19.67	4.62	18.28	4.25
15	13.7	23.72	5.46	22.33	5.08	21.00	4.72	20.33	4.54	19.67	4.36	18.28	4.01	
110%	-14.7	-15	12.33	4.41	12.28	4.60	12.22	4.78	12.22	4.87	12.22	4.97	12.17	5.15
	-12.6	-13	12.83	4.56	12.83	4.74	12.78	4.91	12.78	5.00	12.72	5.09	12.72	5.27
	-10.5	-11	13.44	4.70	13.39	4.87	13.39	5.04	13.33	5.13	13.33	5.21	13.33	5.38
	-9.5	-10	13.78	4.78	13.72	4.94	13.67	5.11	13.67	5.19	13.67	5.28	13.61	5.44
	-8.5	-9.1	14.06	4.84	14.00	5.01	14.00	5.17	13.94	5.25	13.94	5.33	13.94	4.86
	-7	-7.6	14.55	4.96	14.55	5.11	14.50	5.26	14.50	5.34	14.50	5.42	14.45	5.58
	-5	-5.6	15.33	5.09	15.28	5.24	15.22	5.39	15.22	5.46	15.22	5.54	15.17	5.69
	-3	-3.7	16.06	5.23	16.06	5.36	16.00	5.51	16.00	5.58	15.94	5.65	15.94	5.79
	0	-0.7	17.33	5.42	17.33	5.55	17.28	5.68	17.28	5.75	17.28	5.81	16.78	5.70
	3	2.2	18.72	5.60	18.67	5.72	18.67	5.84	18.61	5.90	18.00	5.66	16.78	5.19
	5	4.1	19.67	5.71	19.67	5.83	19.28	5.77	18.61	5.54	18.00	5.32	16.78	4.88
	7	6	20.67	5.81	20.50	5.85	19.28	5.42	18.61	5.21	18.00	5.00	16.78	4.59
	9	7.9	21.72	5.91	20.50	5.50	19.28	5.10	18.61	4.90	18.00	4.70	16.78	4.33
	11	9.8	21.72	5.56	20.50	5.18	19.28	4.80	18.61	4.62	18.00	4.43	16.78	4.08
	13	11.8	21.72	5.21	20.50	4.86	19.28	4.51	18.61	4.34	18.00	4.17	16.78	3.85
15	13.7	21.72	4.63	20.50	4.58	19.28	4.26	18.61	4.10	18.00	3.95	16.78	3.64	
100%	-14.7	-15	12.28	4.70	12.22	4.87	12.17	5.04	12.17	5.13	12.17	5.21	12.11	5.38
	-12.6	-13	12.78	4.84	12.78	5.00	12.72	5.16	12.72	5.24	12.72	5.33	12.67	5.49
	-10.5	-11	13.39	4.97	13.33	5.13	13.33	5.28	13.33	5.36	13.28	5.44	13.28	5.59
	-9.5	-10	13.72	5.04	13.67	5.19	13.67	5.34	13.61	5.42	13.61	5.50	13.56	5.65

	-8.5	-9.1	14.00	5.10	13.94	5.25	13.94	5.39	13.94	5.47	13.89	5.55	13.89	5.69
	-7	-7.6	14.50	5.20	14.50	5.34	14.44	5.48	14.44	5.56	14.44	5.63	14.39	5.77
	-5	-5.6	15.28	5.33	15.22	5.46	15.22	5.60	15.17	5.66	15.17	5.73	15.11	5.87
	-3	-3.7	16.00	5.45	16.00	4.95	15.94	5.71	15.94	5.77	15.94	5.83	15.28	5.59
	0	-0.7	17.28	5.63	17.28	5.75	17.22	5.87	16.95	5.77	16.39	5.53	15.28	5.07
	3	2.2	18.67	5.79	18.61	5.90	17.50	5.46	16.95	5.24	16.39	5.04	15.28	4.62
	5	4.1	19.61	5.90	18.61	5.54	17.50	5.13	16.95	4.94	16.39	4.74	15.28	4.36
	7	6	19.72	5.60	18.61	5.21	17.50	4.83	16.95	4.65	16.39	4.47	15.28	4.11
	9	7.9	19.72	5.26	18.61	4.90	17.50	4.55	16.95	4.32	16.39	4.21	15.28	3.88
	11	9.8	19.72	4.95	18.61	4.62	17.50	4.29	16.95	4.13	16.39	3.97	15.28	3.66
	13	11.8	19.72	4.65	18.61	4.34	17.50	4.04	16.95	3.89	16.39	3.74	15.28	3.46
	15	13.7	19.72	4.38	18.61	4.10	17.50	3.81	16.95	3.68	16.39	3.54	15.28	3.27
90%	-14.7	-15	12.20	5.01	12.14	5.16	12.14	5.31	12.09	5.38	12.09	5.46	12.09	5.61
	-12.6	-13	12.70	5.12	12.70	5.27	12.64	5.41	12.64	5.49	12.64	5.56	12.59	5.70
	-10.5	-11	13.31	5.24	13.31	5.38	13.25	5.52	13.25	5.59	13.25	5.66	13.20	5.80
	-9.5	-10	13.64	5.31	13.59	5.44	13.59	5.58	13.53	5.65	13.53	5.71	13.53	5.85
	-8.5	-9.1	13.92	5.36	13.92	5.49	13.86	5.63	13.86	5.69	13.86	5.76	13.70	5.81
	-7	-7.6	14.42	5.45	14.42	5.58	14.36	5.71	14.36	5.77	14.36	5.83	13.70	5.55
	-5	-5.6	15.20	5.57	15.14	5.69	15.14	5.81	15.08	5.87	14.70	5.69	13.70	5.22
	-3	-3.7	15.92	5.68	15.92	5.79	15.75	5.81	15.20	5.58	14.70	5.36	13.70	4.92
	0	-0.7	17.25	5.84	16.75	5.70	15.75	5.28	15.20	5.07	14.70	4.87	13.70	4.47
	3	2.2	17.75	5.56	16.75	5.18	15.75	4.80	15.20	4.62	14.70	4.44	13.70	4.09
	5	4.1	17.75	5.23	16.75	4.87	15.75	4.53	15.20	4.35	14.70	4.19	13.70	3.86
	7	6	17.75	4.92	16.75	4.59	15.75	4.27	15.20	4.11	14.70	3.95	13.70	3.64
	9	7.9	17.75	4.64	16.75	4.32	15.75	4.02	15.20	3.88	14.70	3.73	13.70	3.44
	11	9.8	17.75	4.37	16.75	4.08	15.75	3.80	15.20	3.66	14.70	3.53	13.70	3.26
	13	11.8	17.75	4.11	16.75	3.85	15.75	3.58	15.20	3.46	14.70	3.33	13.70	3.08
15	13.7	17.75	3.88	16.75	3.63	15.75	3.39	15.20	3.27	14.70	3.16	13.70	2.92	
80%	-14.7	-15	12.17	5.30	12.11	5.43	12.11	5.57	12.11	5.63	12.06	5.70	12.06	5.84
	-12.6	-13	12.67	5.41	12.67	5.54	12.61	5.66	12.61	5.73	12.61	5.80	12.22	5.64
	-10.5	-11	13.28	5.51	13.28	5.64	13.22	5.76	13.22	5.82	13.11	5.81	12.22	5.33
	-9.5	-10	13.61	5.57	13.55	5.69	13.56	5.81	13.56	5.87	13.11	5.64	12.22	5.17
	-8.5	-9.1	13.89	5.62	12.91	5.74	13.83	5.85	13.56	5.72	13.11	5.49	12.22	5.03
	-7	-7.6	14.39	5.70	14.39	5.81	14.00	5.69	13.56	5.46	13.11	5.24	12.22	4.81
	-5	-5.6	15.17	5.80	14.89	5.77	14.00	5.34	13.56	5.14	13.11	4.93	12.22	4.53
	-3	-3.7	15.78	5.83	14.89	5.43	14.00	5.03	13.56	4.84	13.11	4.65	12.22	4.28
	0	-0.7	15.78	5.29	14.89	4.93	14.00	4.58	13.56	4.41	13.11	4.23	12.22	3.90
	3	2.2	15.78	4.82	14.89	4.50	14.00	4.18	13.56	4.03	13.11	3.88	12.22	3.58
	5	4.1	15.78	4.54	14.89	4.24	14.00	3.95	13.56	3.80	13.11	3.66	12.22	3.38
	7	6	15.78	4.28	14.89	4.00	14.00	3.73	13.56	3.59	13.11	3.46	12.22	3.20
	9	7.9	15.78	4.04	14.89	3.78	14.00	3.52	13.56	3.39	13.11	3.27	12.22	3.03
	11	9.8	15.78	3.81	14.89	3.57	14.00	3.33	13.56	3.21	13.11	3.10	12.22	2.87
	13	11.8	15.78	3.59	14.89	3.37	14.00	3.15	13.56	3.04	13.11	2.93	12.22	2.72
15	13.7	15.78	3.40	14.89	3.19	14.00	2.99	13.56	2.88	13.11	2.78	12.22	2.58	
70%	-14.7	-15	12.08	5.60	12.03	5.71	12.03	5.83	11.81	5.75	11.42	5.51	10.64	5.06
	-12.6	-13	12.58	5.69	12.58	5.80	12.25	5.66	11.81	5.44	11.42	5.23	10.64	4.79
	-10.5	-11	13.19	5.78	13.03	5.78	12.25	5.35	11.81	5.14	11.42	4.94	10.64	4.53
	-9.5	-10	13.53	5.83	13.03	5.61	12.25	5.19	11.81	4.99	11.42	4.80	10.64	4.41
	-8.5	-9.1	13.80	5.86	13.03	5.46	12.25	5.06	11.81	4.86	11.42	4.67	10.64	4.30
	-7	-7.6	13.80	5.60	13.03	5.21	12.25	4.84	11.81	4.65	11.42	4.47	10.64	4.11
	-5	-5.6	13.80	5.26	13.03	4.90	12.25	4.55	11.81	4.38	11.42	5.17	10.64	3.88
	-3	-3.7	13.80	4.96	13.03	4.62	12.25	4.30	11.81	4.13	11.42	3.98	10.64	3.67
	0	-0.7	13.80	4.51	13.03	4.22	12.25	3.92	11.81	3.78	11.42	3.64	10.64	3.36
	3	2.2	13.80	4.12	13.03	3.86	12.25	3.59	11.81	3.46	11.42	3.34	10.64	3.09
	5	4.1	13.80	3.89	13.03	3.64	12.25	3.40	11.81	3.27	11.42	3.15	10.64	2.92
	7	6	13.80	3.68	13.03	3.44	12.25	3.21	11.81	3.10	11.42	2.99	10.64	2.77
9	7.9	13.80	3.47	13.03	3.26	12.25	3.04	11.81	2.94	11.42	2.84	10.64	2.63	
11	9.8	13.80	3.29	13.03	3.08	12.25	2.89	11.81	2.78	11.42	2.69	10.64	2.50	

	13	11.8	13.80	3.10	13.03	2.92	12.25	2.73	11.81	2.64	11.42	2.55	10.64	2.37
	15	13.7	13.80	2.94	13.03	2.77	12.25	2.59	11.81	2.51	11.42	2.42	10.64	2.26
60%	-14.7	-15	11.83	5.75	11.17	5.34	10.50	4.96	10.17	4.77	9.83	4.58	9.17	4.21
	-12.6	-13	11.83	5.44	11.17	5.06	10.50	4.70	10.17	4.52	9.83	4.35	9.17	4.02
	-10.5	-11	11.83	5.14	11.17	4.79	10.50	4.45	10.17	4.28	9.83	4.11	9.17	3.79
	-9.5	-10	11.83	4.99	11.17	4.65	10.50	4.32	10.17	4.16	9.83	4.00	9.17	3.69
	-8.5	-9.1	11.83	4.86	11.17	4.53	10.50	4.22	10.17	4.06	9.83	3.90	9.17	3.60
	-7	-7.6	11.83	4.65	11.17	4.34	10.50	4.03	10.17	3.89	9.83	3.74	9.17	3.46
	-5	-5.6	11.83	4.38	11.17	4.09	10.50	3.81	10.17	3.67	9.83	3.53	9.17	3.27
	-3	-3.7	11.83	4.13	11.17	3.86	10.50	3.60	10.17	3.47	9.83	3.34	9.17	3.09
	0	-0.7	11.83	3.78	11.17	3.54	10.50	3.30	10.17	3.19	9.83	3.07	9.17	2.84
	3	2.2	11.83	3.46	11.17	3.25	10.50	3.04	10.17	2.93	9.83	2.83	9.17	2.62
	5	4.1	11.83	3.27	11.17	3.07	10.50	2.87	10.17	2.78	9.83	2.68	9.17	2.49
	7	6	11.83	3.10	11.17	2.91	10.50	2.72	10.17	2.63	9.83	2.55	9.17	2.36
	9	7.9	11.83	2.94	11.17	2.76	10.50	2.58	10.17	2.50	9.83	2.41	9.17	2.25
	11	9.8	11.83	2.78	11.17	2.62	10.50	2.46	10.17	2.38	9.83	2.30	9.17	2.15
	13	11.8	11.83	2.63	11.17	2.48	10.50	2.33	10.17	2.26	9.83	2.18	9.17	2.04
15	13.7	11.83	2.51	11.17	2.36	10.50	2.22	10.17	2.15	9.83	2.08	9.17	1.94	
50%	-14.7	-15	9.86	4.60	9.30	4.30	8.75	4.00	8.42	3.85	8.14	3.71	7.59	3.42
	-12.6	-13	9.86	4.37	9.30	4.08	8.75	3.80	8.42	3.66	8.14	3.53	7.59	3.26
	-10.5	-11	9.86	4.14	9.30	3.87	8.75	3.61	8.42	3.47	8.14	3.35	7.59	3.10
	-9.5	-10	9.86	4.03	9.30	3.76	8.75	3.51	8.42	3.39	8.14	3.26	7.59	3.02
	-8.5	-9.1	9.86	3.93	9.30	3.68	8.75	3.42	8.42	3.31	8.14	3.19	7.59	2.95
	-7	-7.6	9.86	3.76	9.30	3.53	8.75	3.29	8.42	3.17	8.14	3.06	7.59	2.84
	-5	-5.6	9.86	3.55	9.30	3.33	8.75	3.11	8.42	3.00	8.14	2.90	7.59	2.68
	-3	-3.7	9.86	3.36	9.30	3.16	8.75	2.95	8.42	2.85	8.14	2.75	7.59	2.55
	0	-0.7	9.86	3.09	9.30	2.90	8.75	2.72	8.42	2.62	8.14	2.53	7.59	2.36
	3	2.2	9.86	2.84	9.30	2.67	8.75	2.50	8.42	2.42	8.14	2.34	7.59	2.18
	5	4.1	9.86	2.70	9.30	2.53	8.75	2.38	8.42	2.30	8.14	2.23	7.59	2.08
	7	6	9.86	2.56	9.30	2.41	8.75	2.26	8.42	2.19	8.14	2.12	7.59	1.98
	9	7.9	9.86	2.43	9.30	2.29	8.75	2.15	8.42	2.09	8.14	2.02	7.59	1.89
	11	9.8	9.86	2.31	9.30	2.18	8.75	2.05	8.42	1.99	8.14	1.93	7.59	1.80
	13	11.8	9.86	2.20	9.30	2.07	8.75	1.95	8.42	1.89	8.14	1.83	7.59	1.72
15	13.7	9.86	2.09	9.30	1.98	8.75	1.86	8.42	1.81	8.14	1.75	7.59	1.64	

8. Electric Characteristics

Model	Outdoor Unit				Power Supply		Compressor	OFM	
	Hz	Voltage	Min.	Max.	TOCA	MFA	RLA	kW	FLA
MDV-V80W/N1	50	220-240	198	253	20.5	50	9.7	0.168	0.78
MDV-V105W/N1	50	220-240	198	254	30	80	13.5	0.185	0.8
MDV-V105W/N1-B	50	220-240	198	254	25	50	9.7	0.269	1.22
MDV-V140W/N1	50	220-240	198	253	30	80	13.5	0.185	0.8
MDV-V105W/BDRN1	50	380-415V	342V	440V	18	30	9.4	0.2	1.4
MDV-V140W/BDRN1	50	380-415V	342V	440V	18	30	9.4	0.1	0.8x 2
MDV-V160W/BDRN1-B	50	380-415V	342V	440V	18	30	15.2	0.176*2	0.87 x 2

Remark:

TOCA: Total Over-current Amps. (A)

MFA: Max. Fuse Amps. (A)

RLA: Rated Locked Amps. (A)

OFM: Outdoor Fan Motor.

FLA: Full Load Amps. (A)

KW: Rated Motor Output (KW)

9. Sound Levels

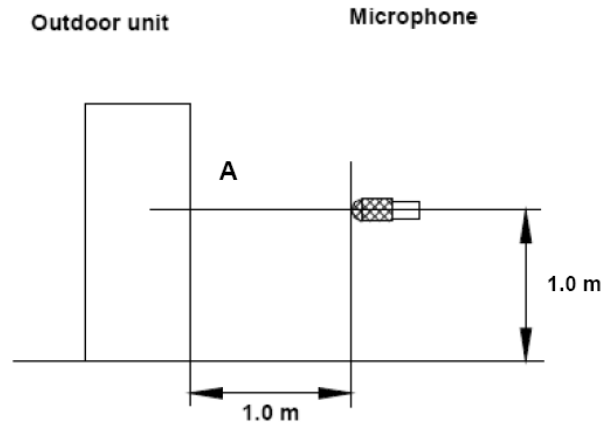

Model	Noise level dB(A)	
	High speed	Low speed
MDV-V80W/N1	57	54
MDV-V105W/N1	57	54
MDV-V105W/N1-B	57	54
MDV-V140W/N1	57	54
MDV-V105W/BDRN1	58	55
MDV-V140W/BDRN1	57	54
MDV-V160W/BDRN1-B	57	54

10.Operation Limits

Cooling

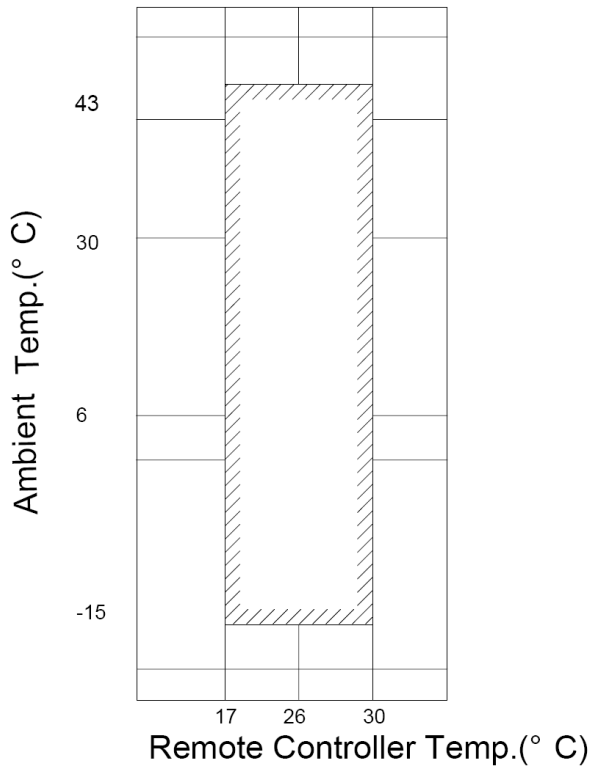

Heating

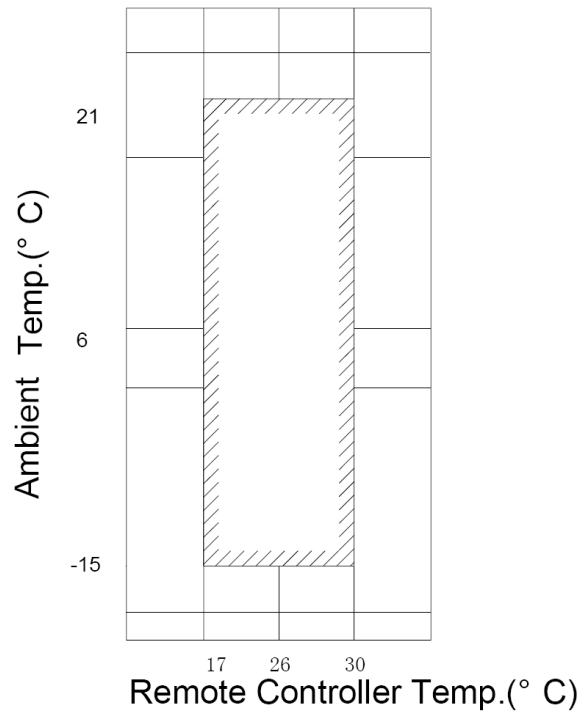

11.Troubleshooting

11.1 Troubles and causes of air conditioner

If one of the following malfunctions occur, stop operation, shut off the power, and contact with your dealer.

- The operation lamp is flashing rapidly (twice every second) This lamp is still flashing rapidly after turn off the power and turn on again.
- Remote controller receives malfunction or the button does not work well.
- A safety device such as a fuse, a breaker frequently actuates.
- Obstacles and water enter the unit.
- Water leaks from indoor unit.
- Other malfunctions.

If the system does not properly operate except the above mentioned cases or the above mentioned malfunctions is evident, investigate the system according to the following procedures.

Symptoms	Causes	Solution
Unit does not start	<ul style="list-style-type: none"> ● Power failure. ● Power switch is off. ● Fuse of power switch may have burned. ● Batteries of remote controller exhausted or other problem of controller. 	<ul style="list-style-type: none"> ● Wait for the comeback of power.. ● Switch on the power. ● Relocation. ● Replace the batteries or check the controller.
Air flowing normally but completely can it cooling	<ul style="list-style-type: none"> ● Temperature is not set correctly. ● Be in 3 minutes protection of compressor 	<ul style="list-style-type: none"> ● Set the temperature properly. ● Wait.
Units start or stop frequently	<ul style="list-style-type: none"> ● Refrigerant is too little or too much. ● Air or no concreting gas in the refrigerating circuit. ● Compressor is malfunction. ● Voltage is too high or too low. ● System circuit is blocked. 	<ul style="list-style-type: none"> ● Check leakage, and rightly recharge refrigerant. ● Vacuum and recharge refrigerant. ● Maintenance or change compressor. ● Install manostat. ● Find reasons and solution.
Low cooling effect	<ul style="list-style-type: none"> ● Outdoor unit and indoor unit heat exchanger is dirty. ● The air filter is dirty. ● Inlet/outlet of indoor/outdoor units is blocked. ● Doors and windows are open. ● Sunlight directly shine. ● Too much heat resource. ● Outdoor temp. is too high. ● Leakage of refrigerant or lack of refrigerant. 	<ul style="list-style-type: none"> ● Clean the heat exchanger. ● Clean the air filter. ● Eliminate all dirties and make air smooth. ● Close doors and windows. ● Make curtains in order to shelter from sunshine. ● Reduce heat source. ● AC cooling capacity reduces normal). ● Check leakage and rightly recharge refrigerant.
Low heating effect	<ul style="list-style-type: none"> ● Outdoor temperature is lower than 7 C ● Doors and windows not completely closed. ● Leakage of refrigerant or lack of refrigerant. 	<ul style="list-style-type: none"> ● Use heating device. ● Close doors and windows. ● Check leakage and rightly recharge refrigerant.

11.2 Troubles and causes of remote controller

Before asking for serving or repairing, check the following points.

Symptoms	Causes	Solution
The fan speed can not be changed.	Check whether the MODE indicated on the display is "AUTO"	When the automatic mode is selected, the air conditioner will automatically change the fan speed.
	Check whether the MODE indicated on the display is "DRY"	When dry operation is selected, the air conditioner automatically change the fan speed. The fan speed can be selected during "COOL" , "FAN ONLY", and "HEAT"
The remote controller signal is not transmitted even when the ON/OFF button is pushed.	Check whether the batteries in the remote controller are exhausted.	The power supply is off.
The TEMP .Indicator does not come on.	Check whether the MODE indicated on the display is FAN ONLY	The temperature cannot be set during FAN mode.
The indication on the display disappears after a lapse of time.	Check whether the timer operation has come to an end when the TIMER OFF is indicated on the display.	The air conditioner operation will stop up to the set time
The TIMER ON indicator goes off after a lapse of certain time.	Check whether the timer operation is started when the TIMER ON is indicated on the display.	Up to the set time, the air conditioner will automatically start and the appropriate indicator will go off.
No receiving tone sounds from the indoor unit even when the ON/OFF button is pressed.	Check whether the signal transmitter of the remote controller is properly directed to the infrared signal receiver of the indoor unit when the ON/OFF button is pressed.	Directly transmit the signal transmitter of the remote controller to the infrared signal receiver of the indoor unit, and then repeatedly push the ON/OFF button twice.

11.3 Malfunction Code of Indoor unit

(1) For the Four-way Cassette (New designed):

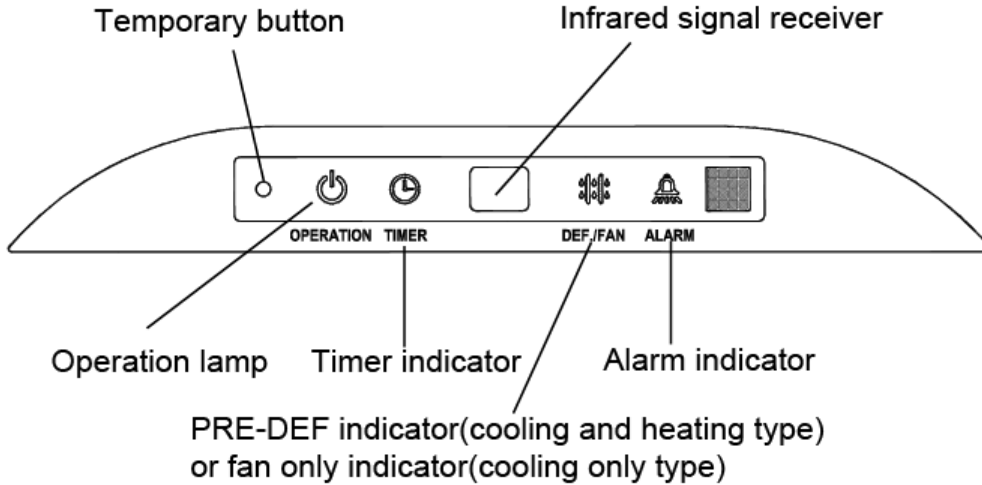

No.	Malfunction	Operation	Timer	DEF/FAN	Alarm	Code
1	Communication malfunction between in-outdoor unit		LED2 Quick-flash			E1
2	Room temperature sensor malfunction	LED1 Quick-flash				E2
3	Pipe temperature sensor malfunction	LED1 Quick-flash				E3
4	Pipe temperature sensor malfunction	LED1 Quick-flash				E4
5	Water level checking malfunction				LED4 Quick-flash	EE
6	EEPROM malfunction	LED1 Slow-flash				E7
7	Mode conflicts malfunction			LED3 Quick-flash		E0
8	Outdoor malfunction				LED4 Slow-flash	Ed

(2) For the Wall-mounted:

No.	Malfunction	Code
1	Communication malfunction between in-outdoor unit	E1
2	T1 Temp. sensor malfunction	E2
3	T2A Temp. sensor malfunction	E3
4	T2B Temp. sensor malfunction	E4
5	Outdoor Unit's (T3 or T4 or digital scroll compressor discharge) Temp. sensor malfunction	E5
6	Mode-confliction malfunction	E6
7	Phase sequence error or Lack of phase	E0
8	Water level checking malfunction	EE

(3) For the other type indoor unit:

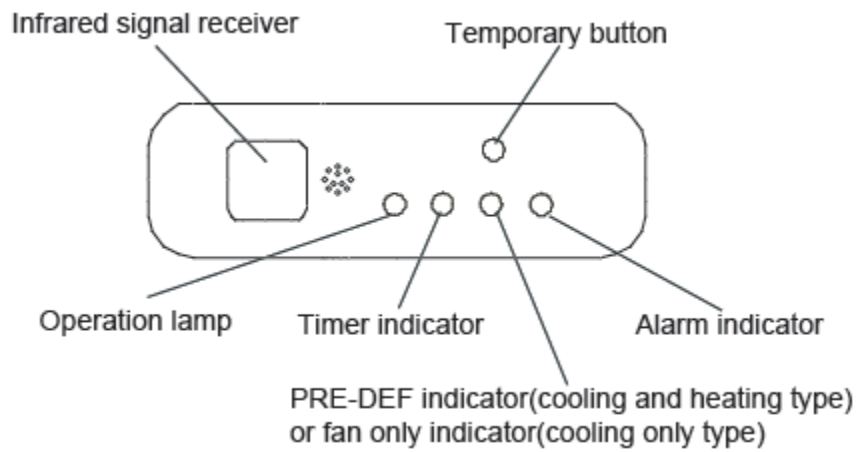

No	Display Contents	Malfunction
1	All lamps are off	Standing-by
2	Operation lamp is on	ON
3	PRE./DEF. lamp is on	Anti-cooling or Defrosting
4	Timer lamp is on	Timer function is on
5	Timer lamp flashes	Indoor/outdoor communication malfunction
6	Operation lamp flashes	Indoor unit's temp. Sensor malfunction
7	PRE/DEF. Lamp flashes	Mode-confliction malfunction
8	Alarm lamp flashes quickly	Water level checking malfunction
9	Alarm lamp flashes slowly	Outdoor malfunction or protection

① Indoor/outdoor communication malfunction

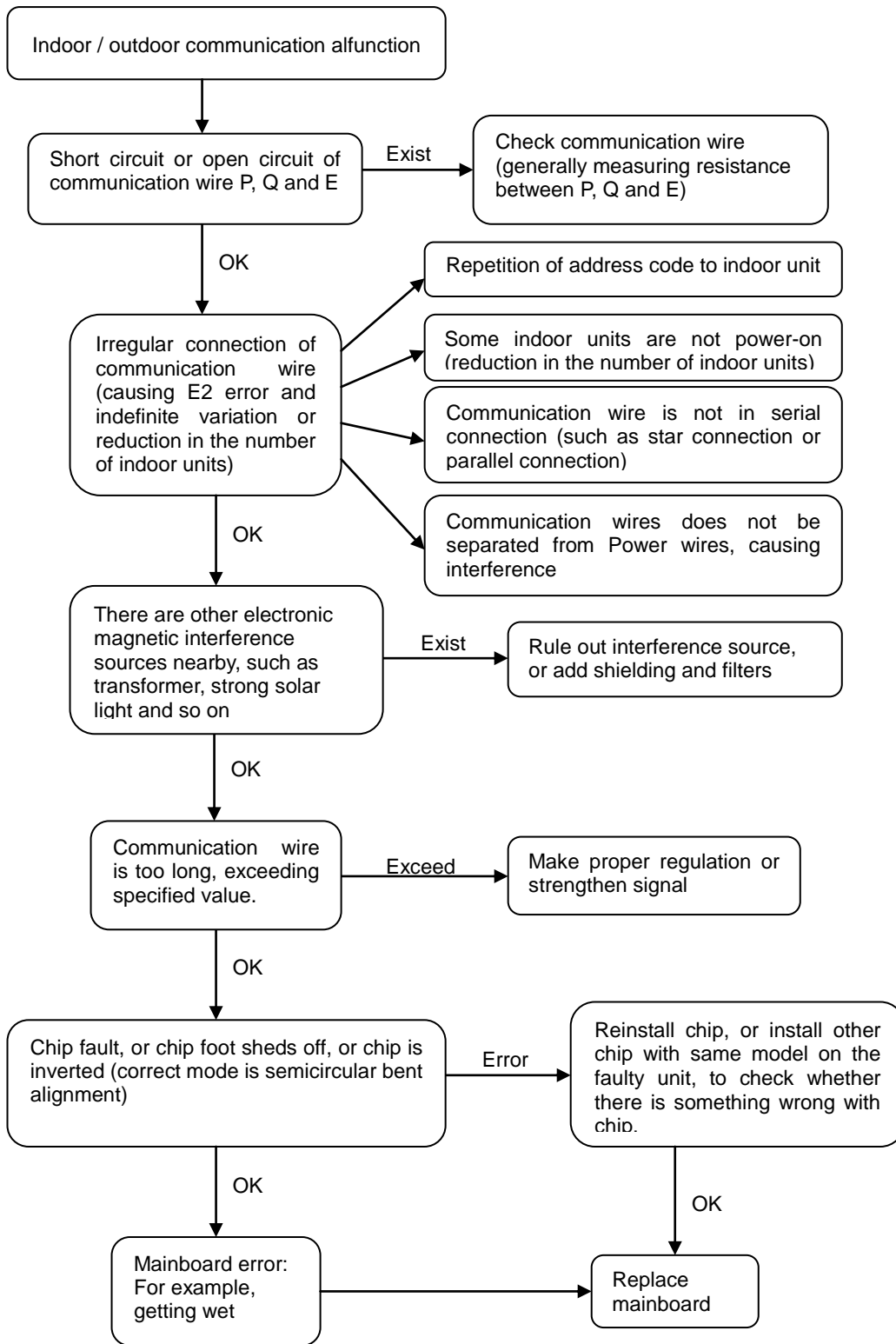

Note:

Press the "manual" button on remote control receiver of indoor unit in turn (display the address code of this indoor unit when pressing and holding for 5 seconds (display capacity code when pressing and holding for 10 seconds), check all address codes.

Codes to be inspected are as follows:

Indicator	OPERATION	TIMER	DEF / FAN	ALARM
Code	8	4	2	1

Address code	0	1	2	3	4	5	6	7	8	9
Capacity (x 100W)	22	28	36	45	56	71	80	90	112	140
Horsepower (HP)	0.8	1.0	1.2	1.6	2.0	2.5	3.0	3.2	4.0	5.0

For example: After pressing and holding for 5 seconds, "Operation" light and "Alarm" light is constant-on, which indicates that the address code is $(8 + 1) = 9$;

(Note: If the indicator is constant-on, calculate according to the above-mentioned formula. If the indicator is flashing, add 16 to the original calculated code, for example: After pressing and holding for 5 seconds, "Operation" light and "Alarm" light is flashing, which indicates that the address code is $16 + (8 + 1) = 25$.)

After pressing and holding for 10 seconds, "Operation" light and "Alarm" light is constant-on, which indicates that the address code is $(4 + 1) = 5$; indicating the capacity of this unit is $71 \times 100W$ (2.5 HP).

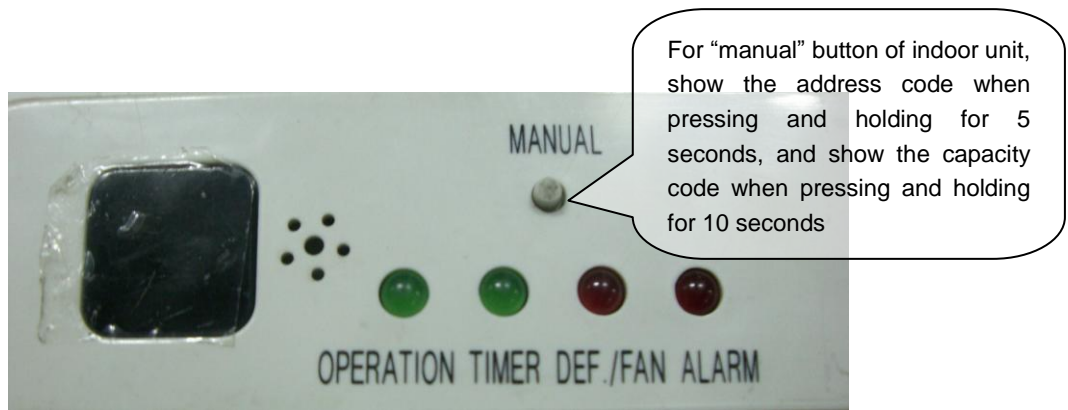

Signal wire must be shielded wire; indoor units must be connected in serial. At the end, connect a resistor on indoor unit or a capacitor between P and Q on outdoor unit.

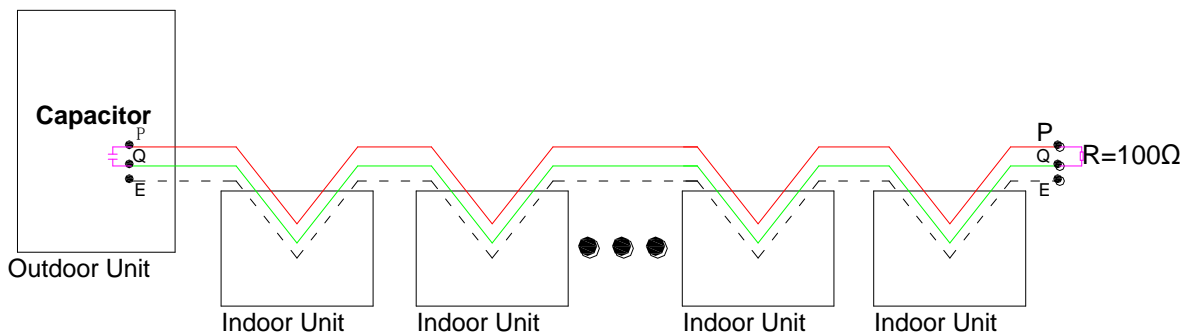

② Indoor unit's temp. Sensor malfunction

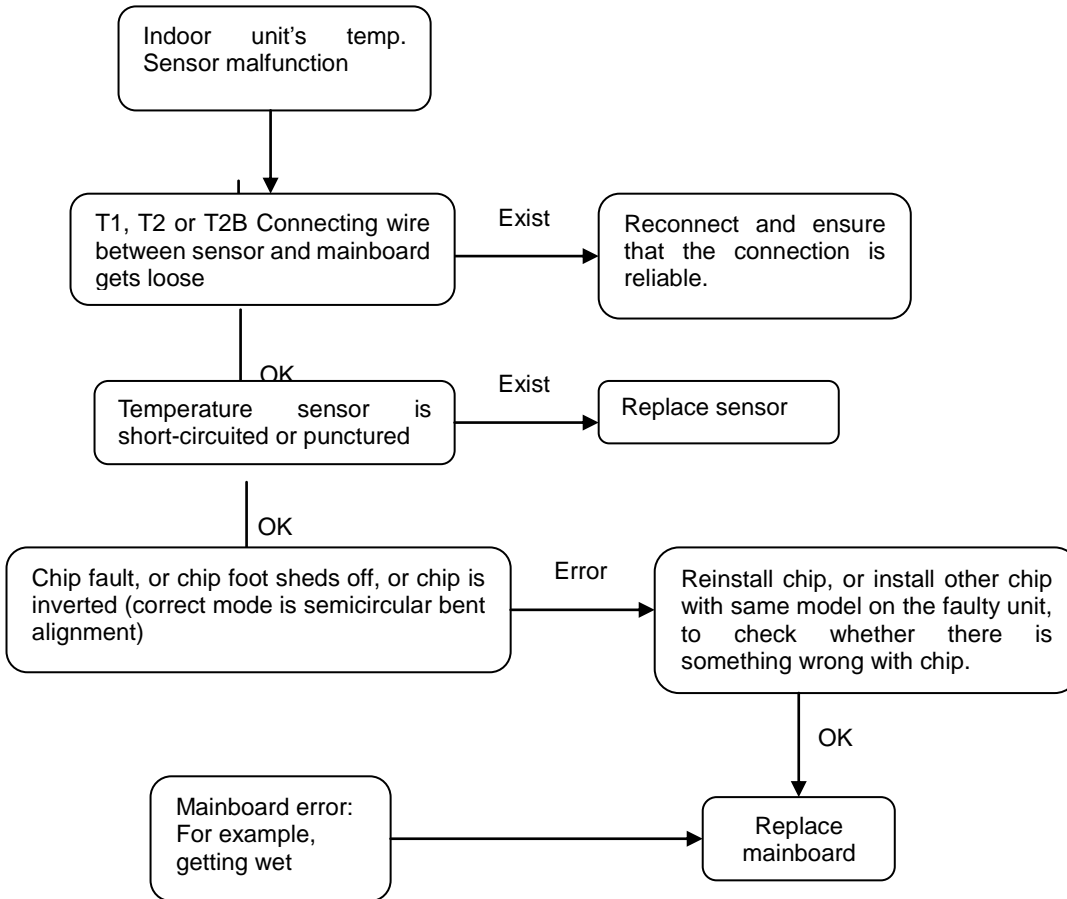

Caution: There are three temp. sensors in indoor unit, i.e. T1, T2 and T2B, of which fault in any one will cause operation light flashing and report error.

③ Mode-conflict malfunction

In the below table, “Yes” indicates existing mode conflict, “No” indicates no mode conflict.

	Cooling	Heating	Air-supply	OFF
Cooling	No	Yes	No	No
Heating	Yes	No	Yes	No
Air-supply	No	Yes	No	No
OFF	No	No	No	No

When indoor unit receiving heating operation instruction, it will transmit the operation mode signal to outdoor unit to conduct prior heating control, including:

In process of cooling and air-supply mode operation: After receiving the heating operation instruction, outdoor unit stops cooling and supplying air, and transfers to heating mode three minutes later after the shutdown of compressor; indoor unit required to conduct cooling and air-supply mode operation is on standby mode and displays mode conflict fault.

In process of heating mode operation: Ignore cooling and air-supply mode operation instruction, outdoor unit keeps on operating according to heating mode; Indoor unit with cooling and air-supply mode operation displays mode conflict fault. If heating mode operation stops (except that indoor unit reaches setting temperature because of heating), cooling and air-supply mode restarts up and conducts operation three minutes later.

④ Water-level switch malfunction

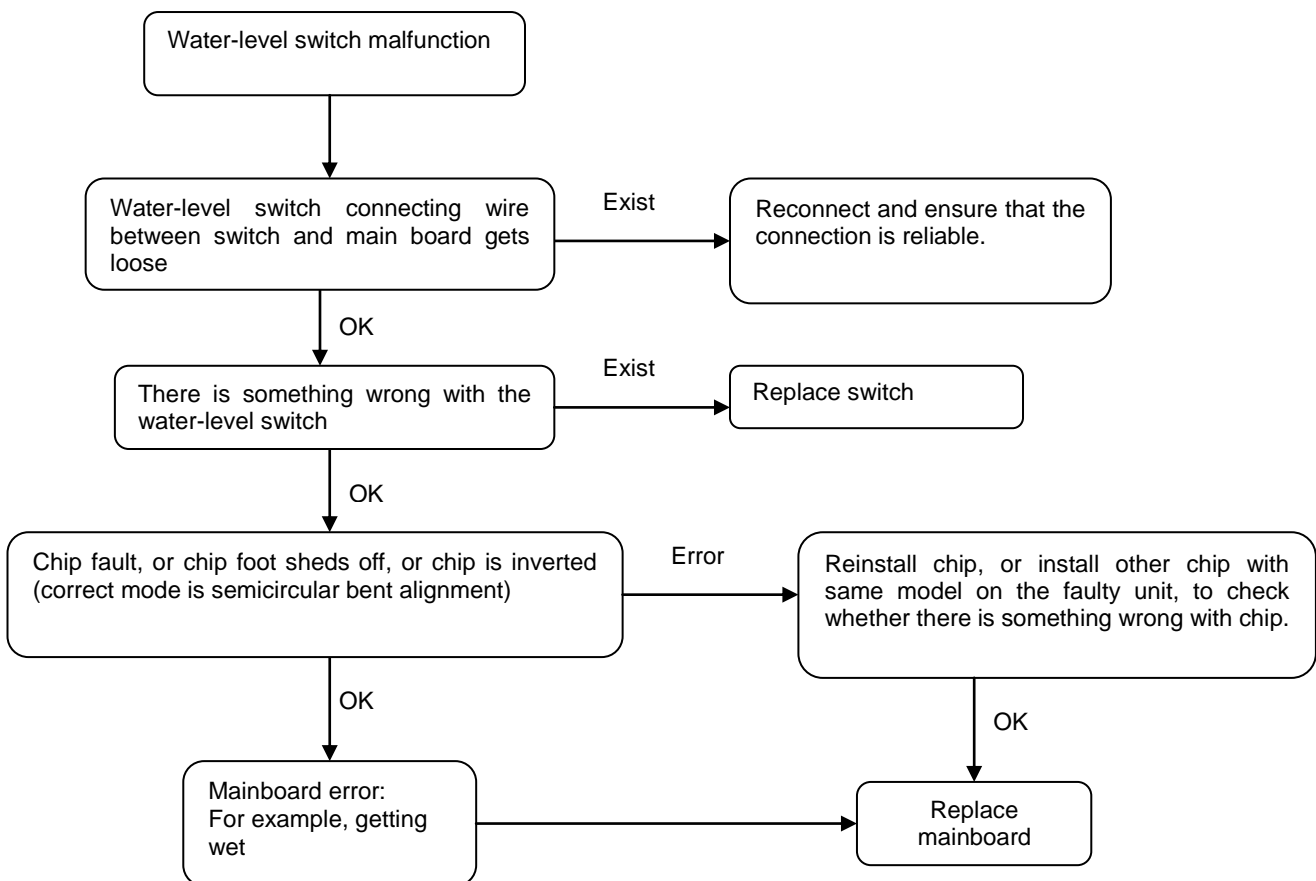

⑤ EEPROM malfunction

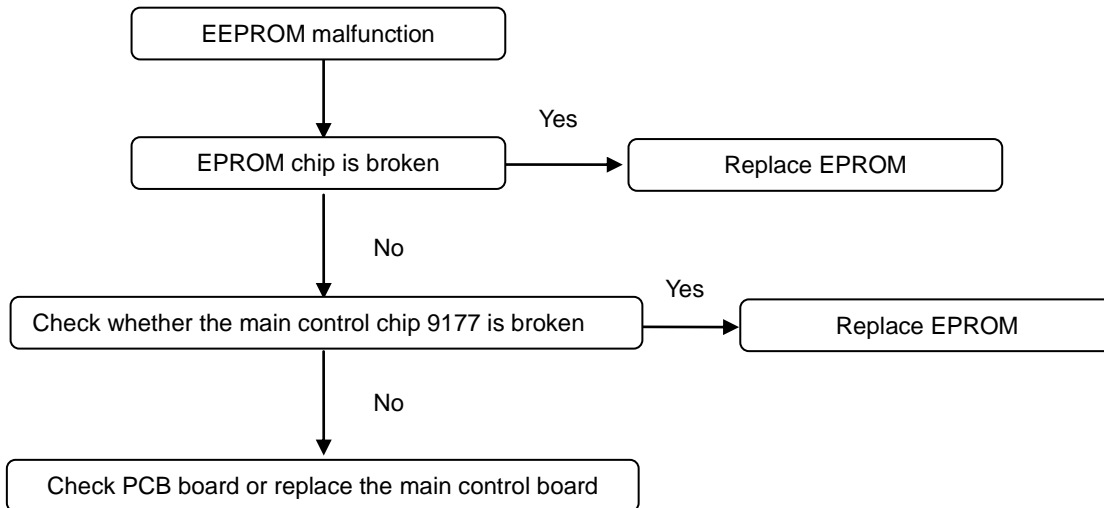

⑥ Outdoor malfunction or protection

Examine outdoor unit, and analyze according to actual condition

⑦ Congealing Dew or Water Leakage in Indoor Units

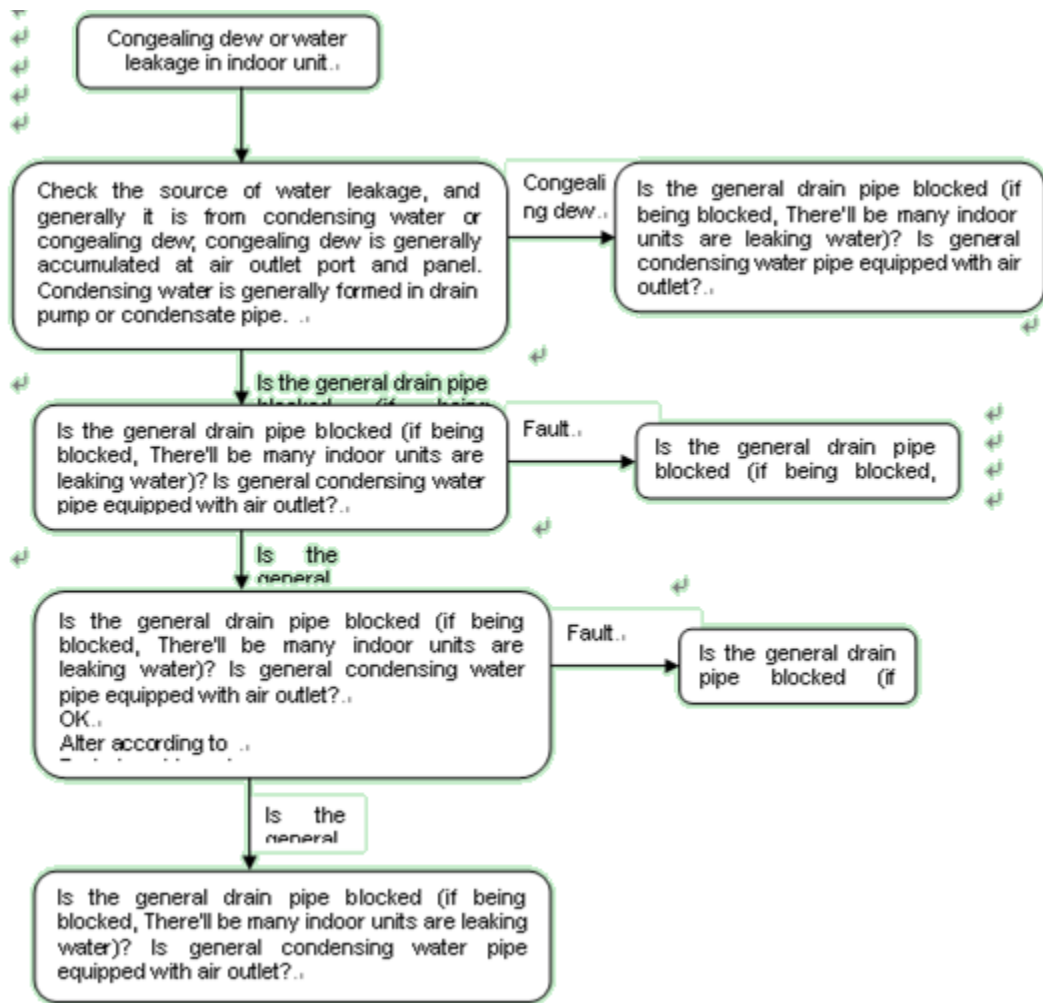

11.4 Malfunction Code of Outdoor unit

Display	Malfunction or Protection
E0	EEPROM malfunction
E2	Communication malfunction between indoor/outdoor units
E3	Communication malfunction between DSP/Outdoor units
E4	T4 temperature sensors malfunction
E5	Outdoor unit voltage protection
E6	PFC module protection (single-phase)
P1	High pressure protection
P2	Low pressure protection
P3	Compressor current protection
P4	Compressor discharge temperature protection
P5	Condenser high temperature protection
P6	IPM protection

1) E0 malfunction

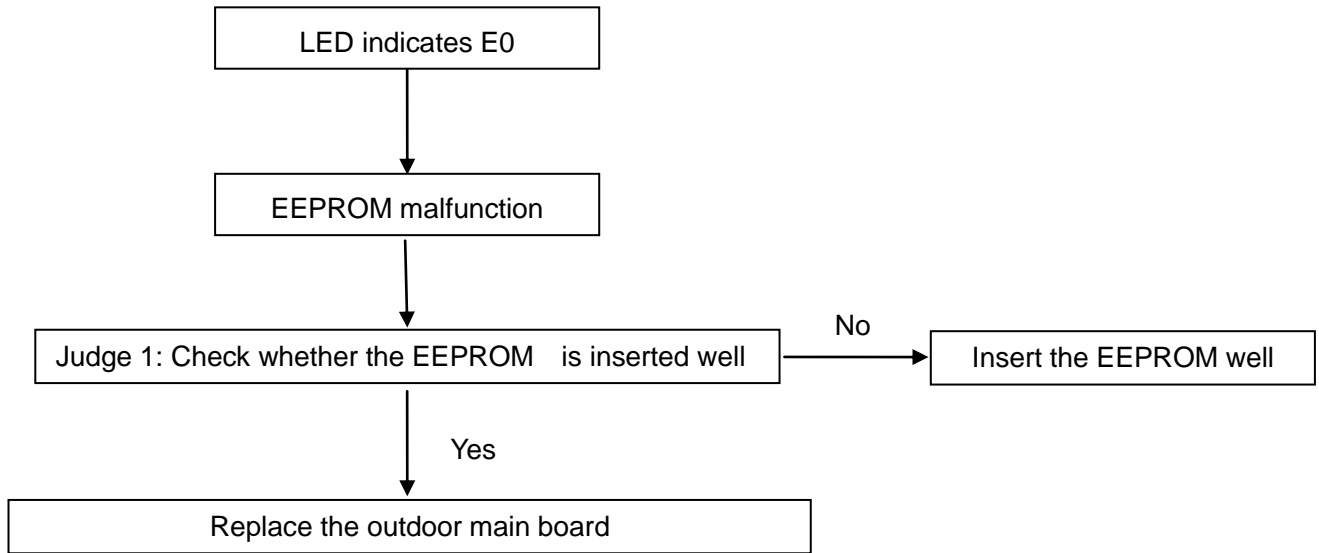

2) E2 malfunction

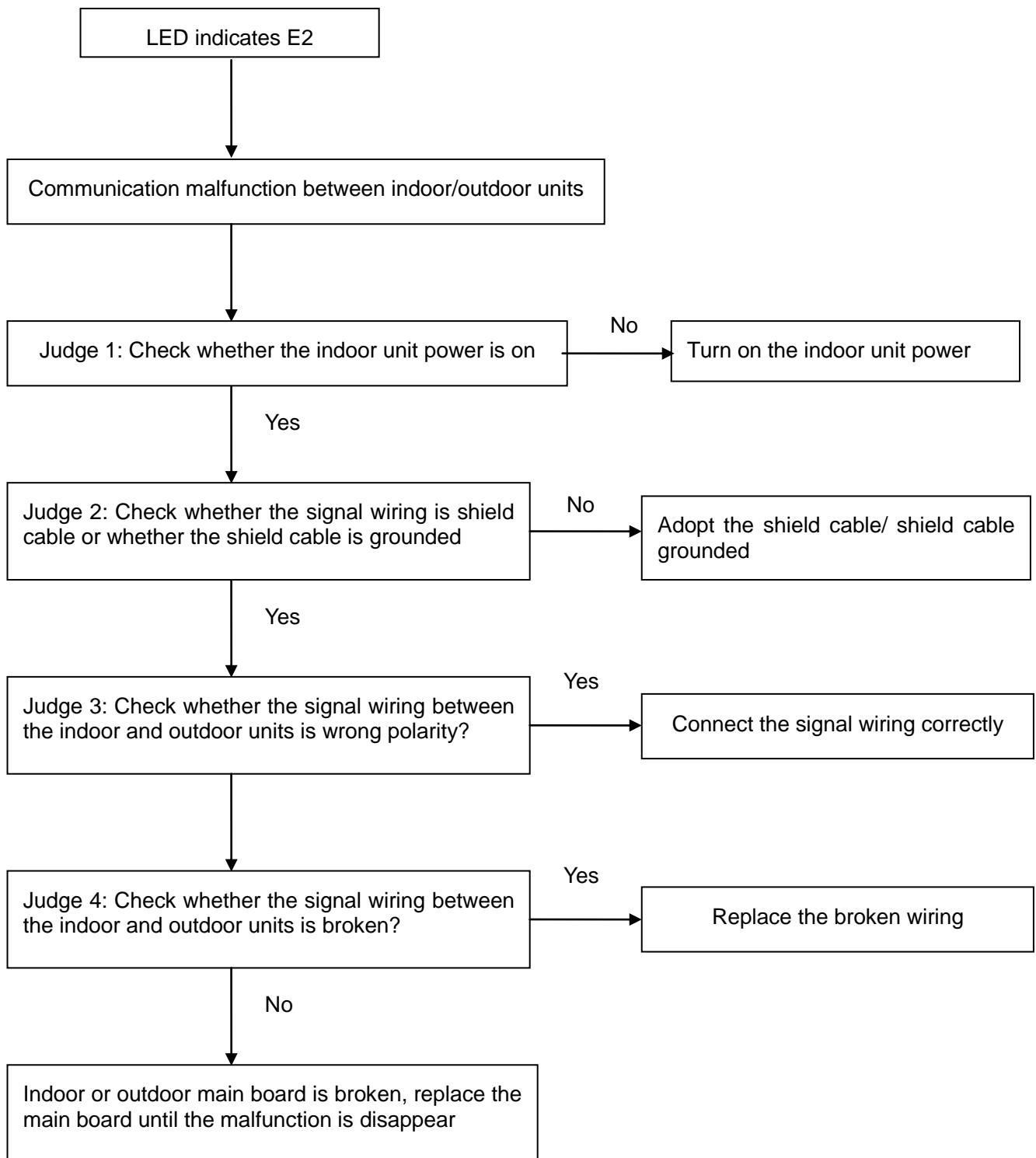

3) E3 malfunction

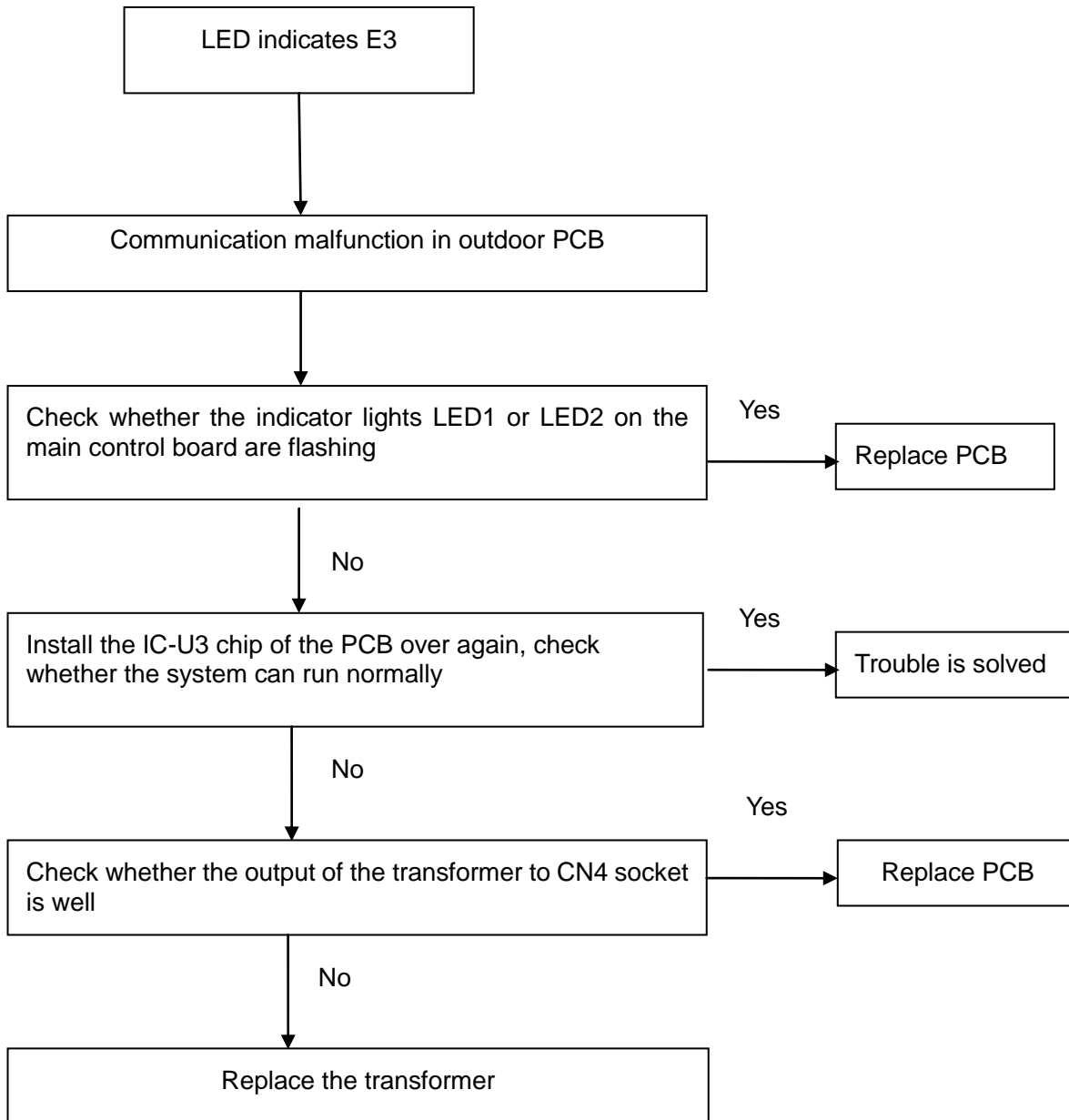

4) E4 malfunction

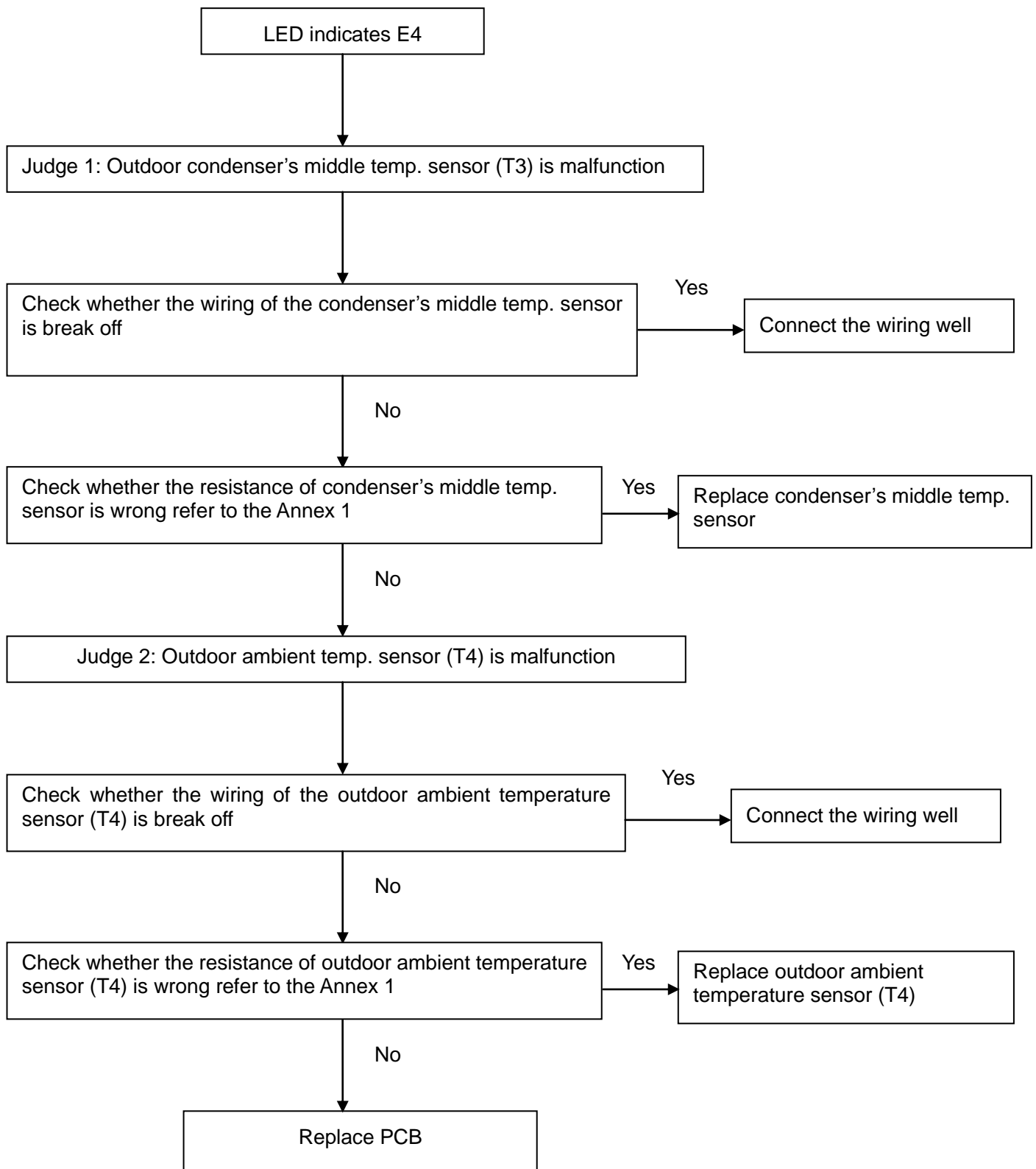

5) E5 malfunction

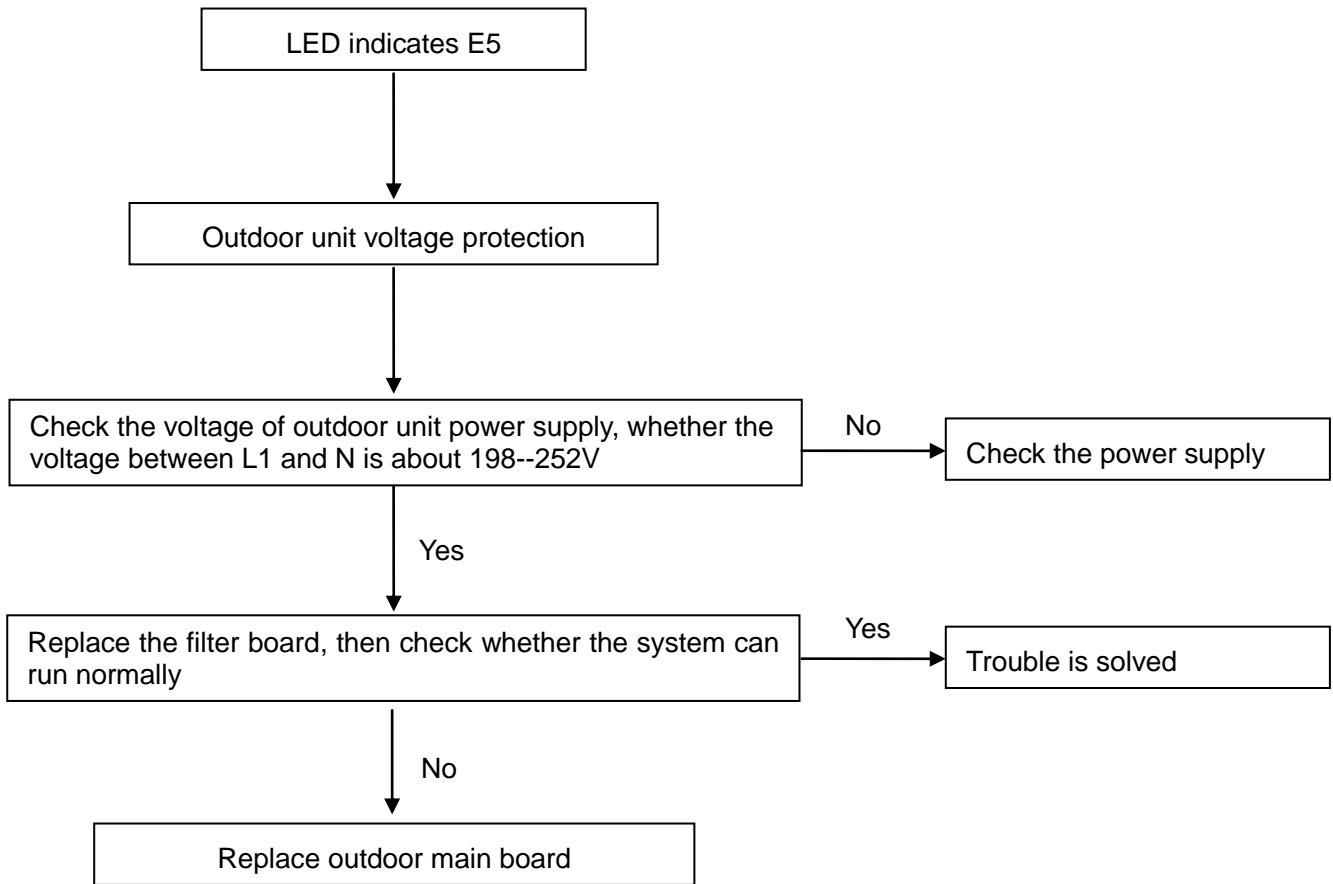

6) E6 malfunction(for single phase)

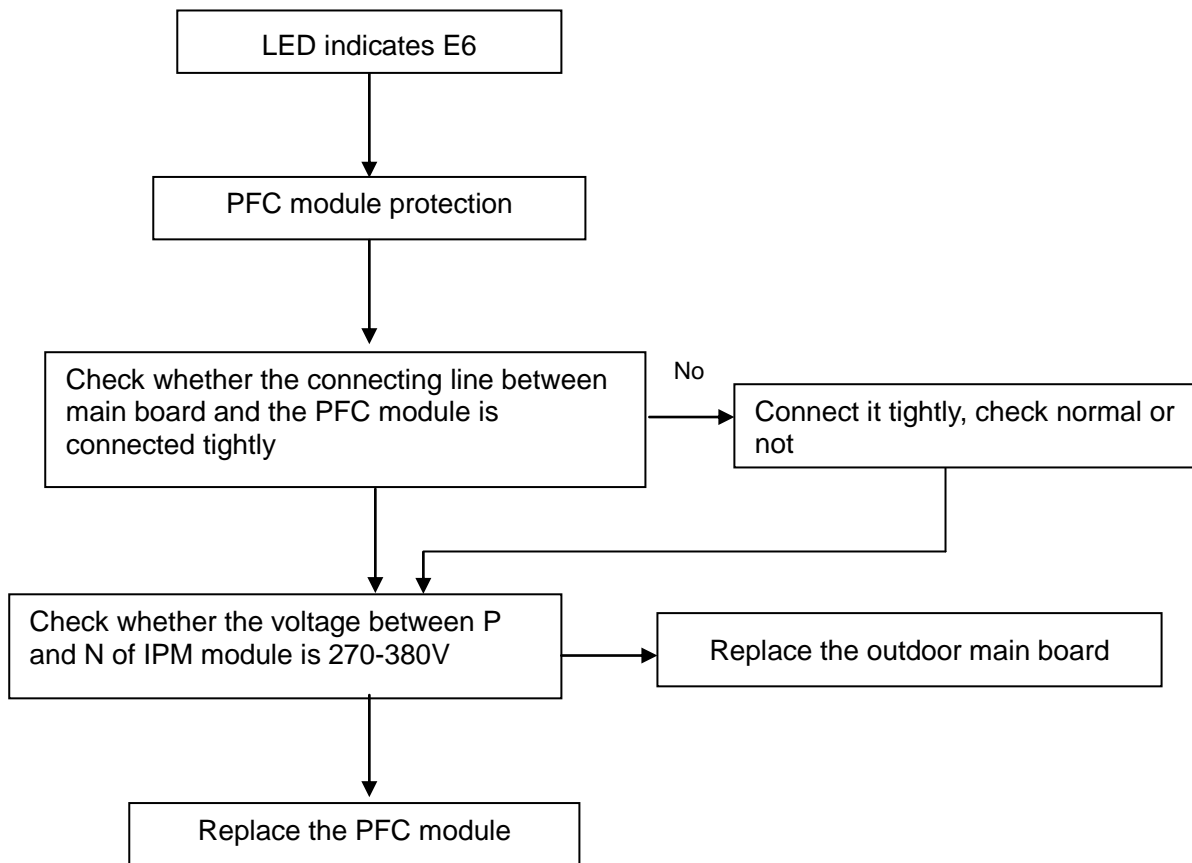

7) P1 malfunction

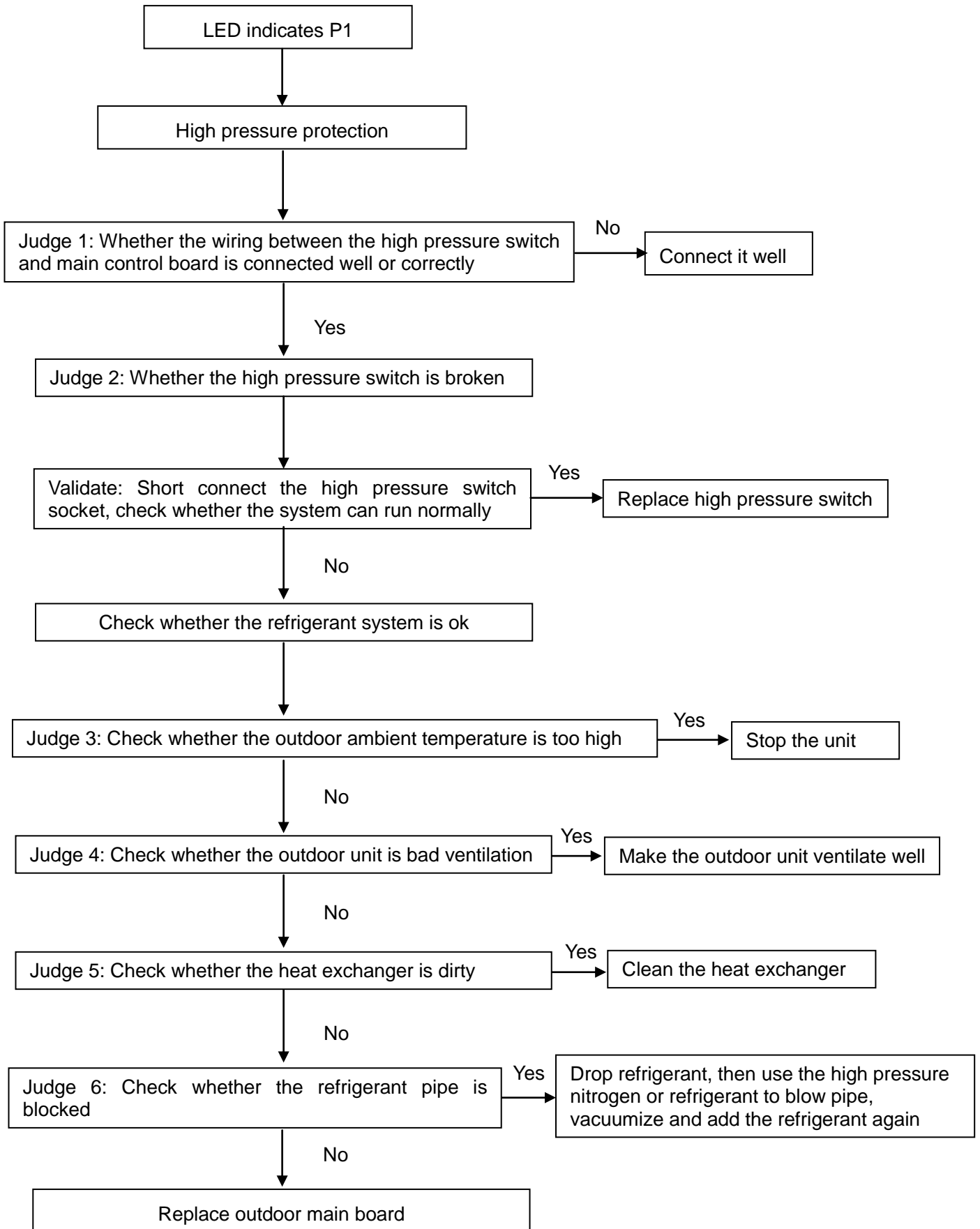

8) P2 malfunction

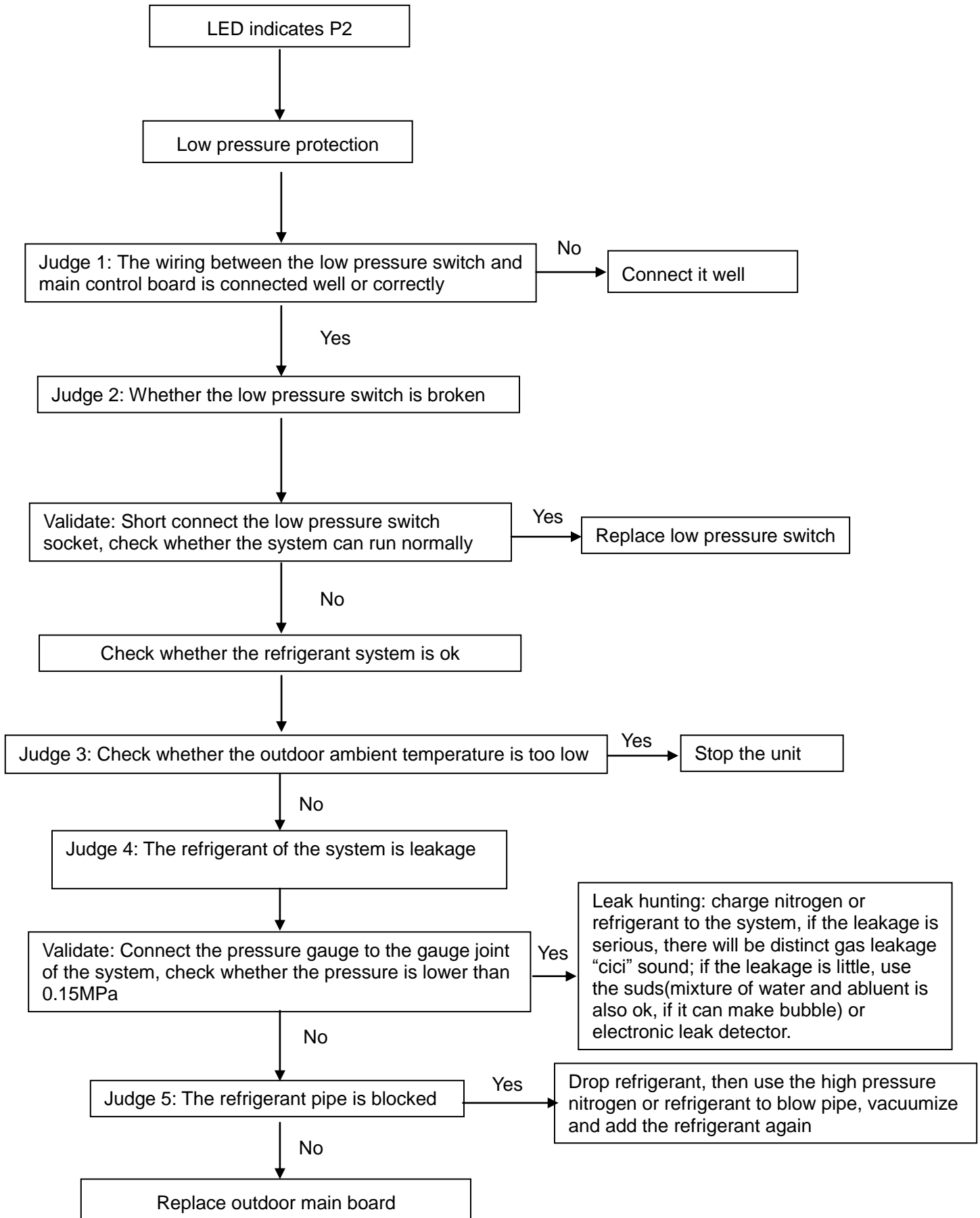

9) P3 malfunction

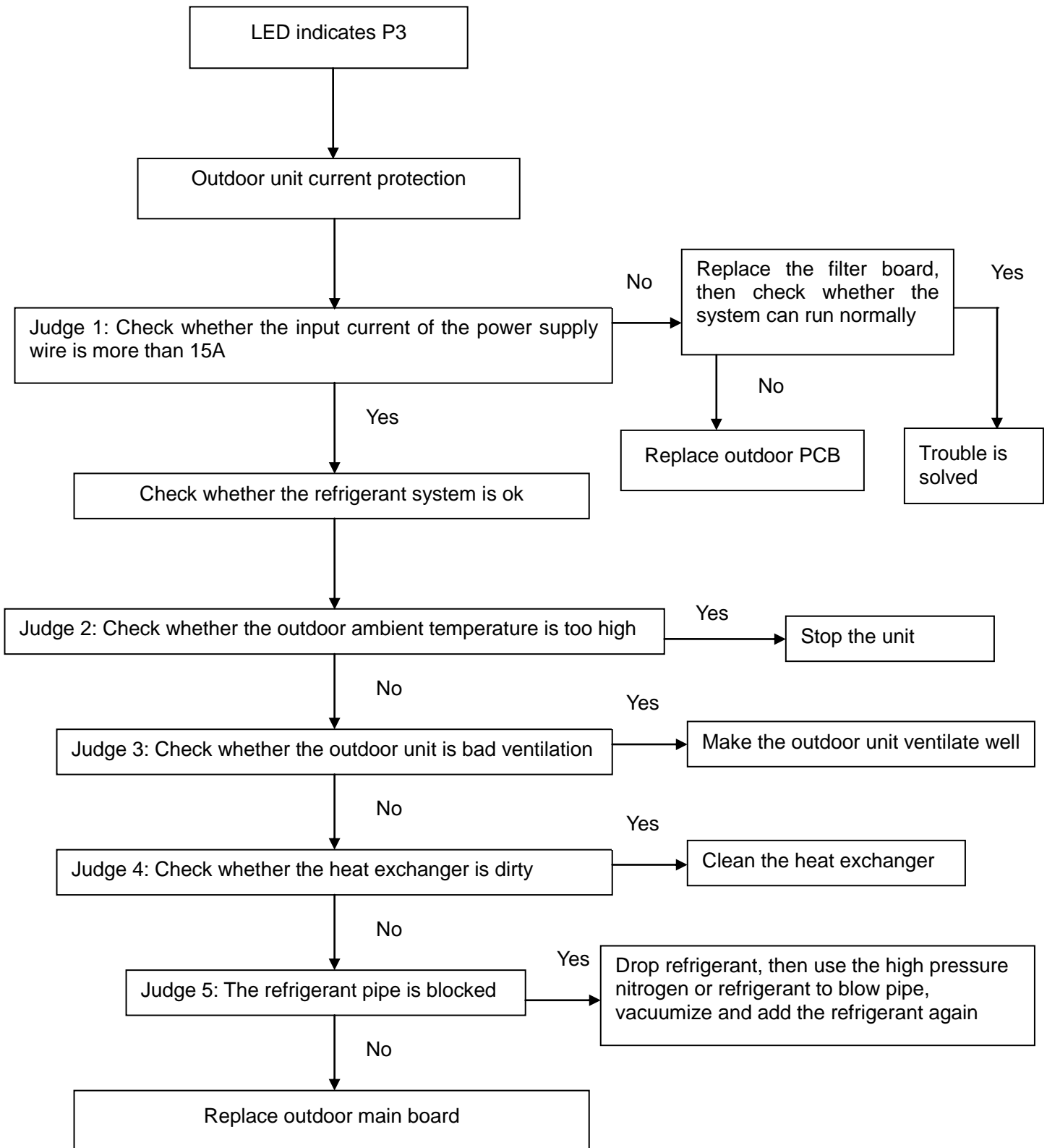

10) P4 malfunction

When compressor discharge temperature is more than 115°C, the unit will stop, and unit runs again when compressor discharge temperature is less than 90°C.

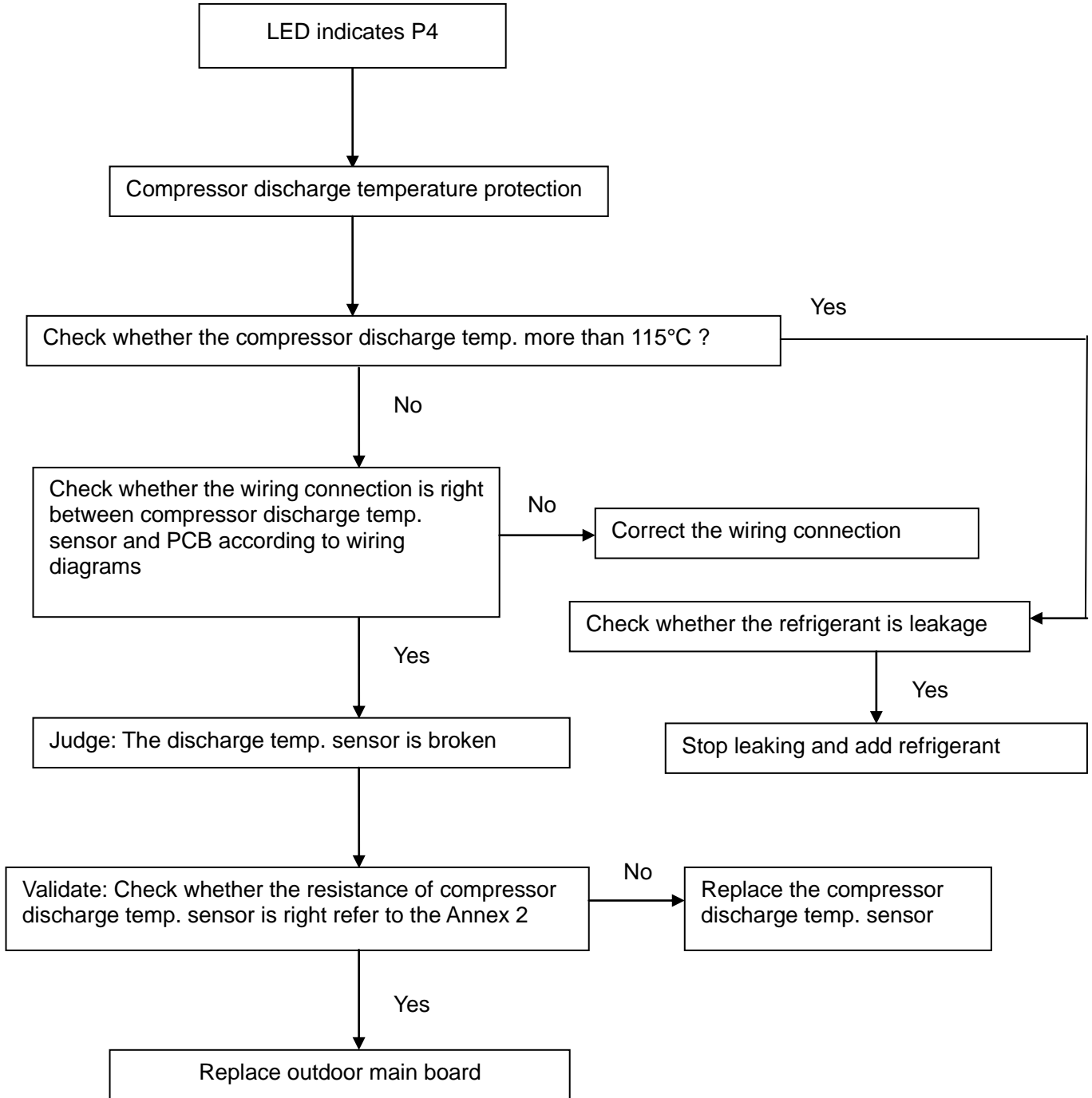

11) P5 malfunction

When condenser high temp. is more than 65°C, the unit will stop, and unit runs again when outdoor pipe temp. less than 52°C.

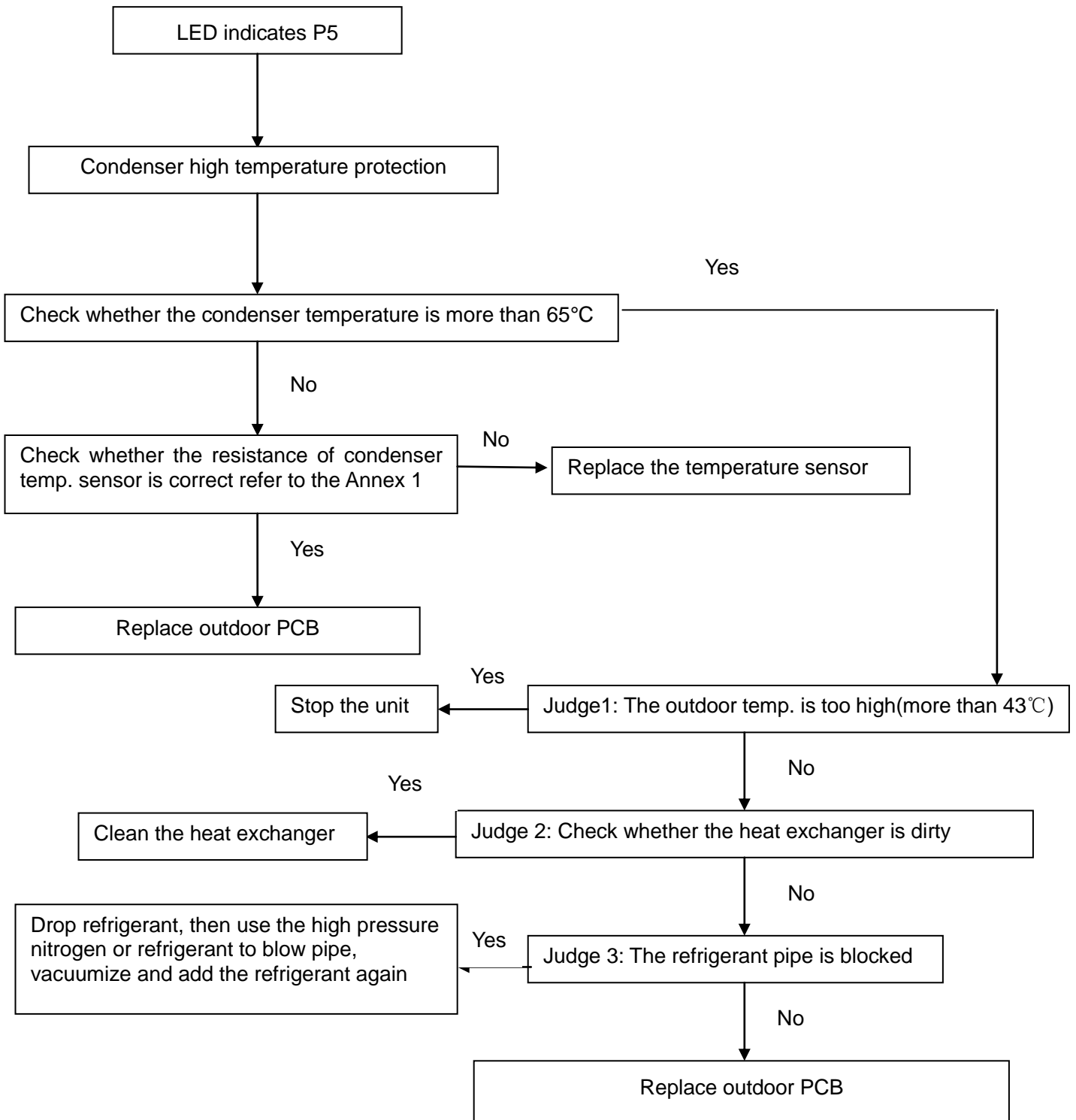

12) P6 malfunction

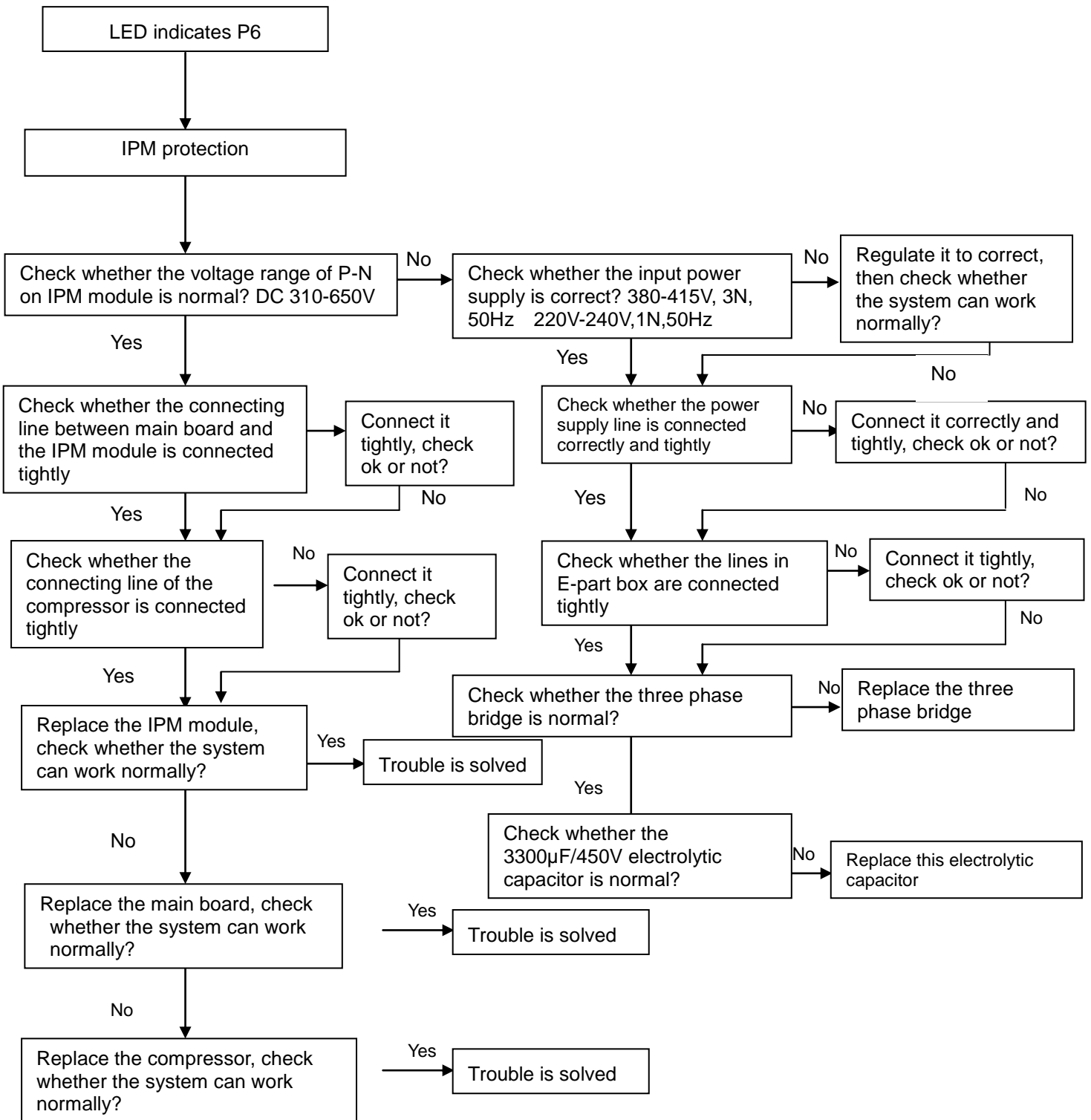

Part 3 Installation

1. Summarize of Installation.....	81
2. Installation of Indoor Unit.....	84
3. Installation of Outdoor Unit.....	86
4. Installation of Refrigerant Pipe	88
5. Processing & Installation of Drainage Pipe	92
6. Insulation Work	95
7. Electric Installation	97
8. Test Running	102
9. Precautions on Refrigerant Leakage	103

1. Summarize of Installation

1.1 Installation Procedure

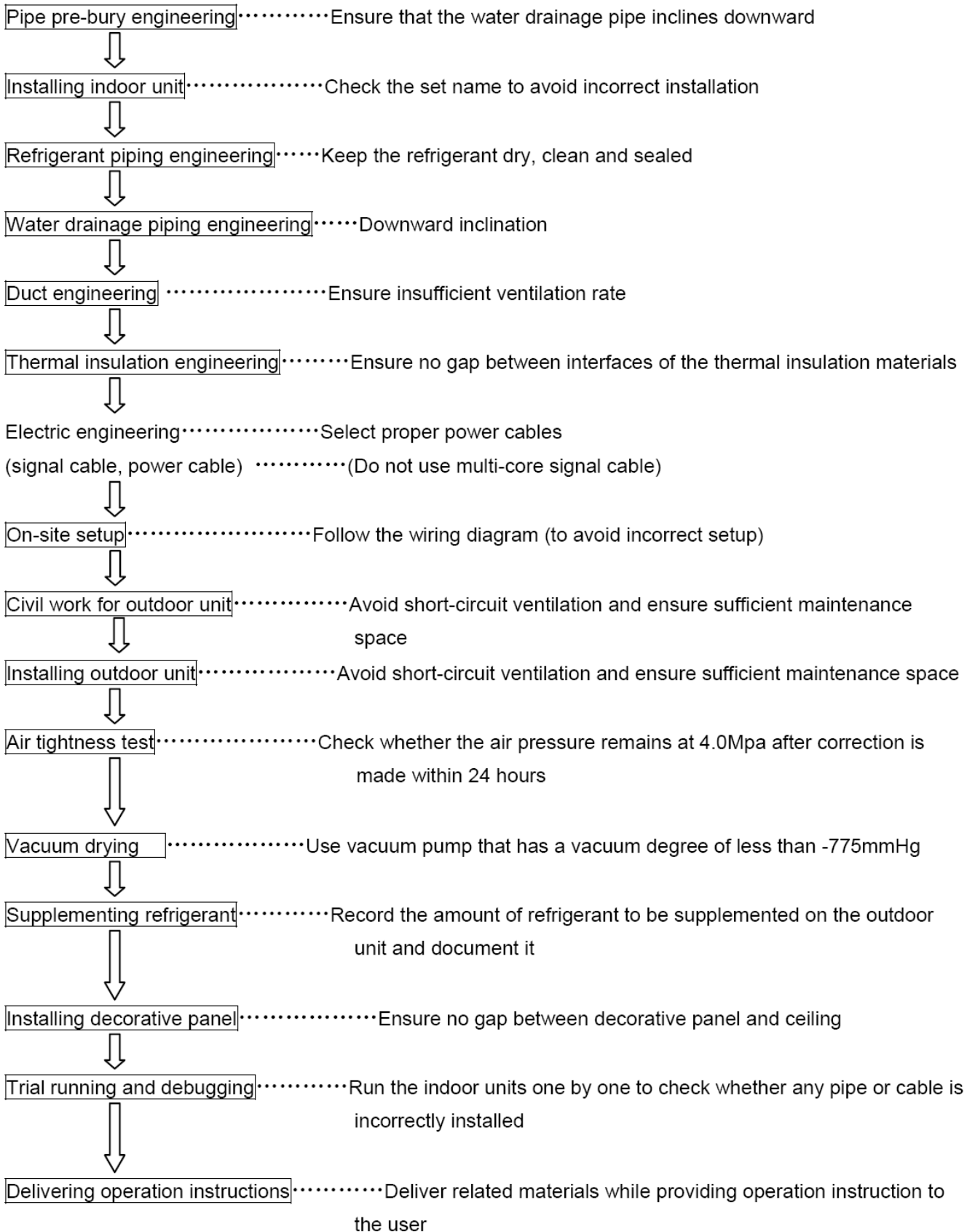

1.2 Install indoor units

Procedure:

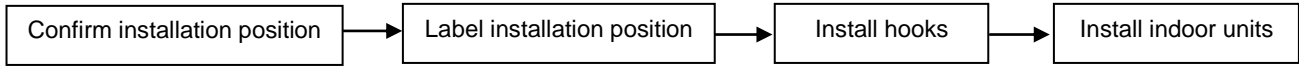

Note:

- (1) The hook must strong enough to sustain the weight of indoor unit.
- (2) Check the models of indoor units before installation.
- (3) Pay attention to the main devices, such as the pipeline.
- (4) Hold enough places for maintenance.

1.3 Refrigerant pipe

Procedure:

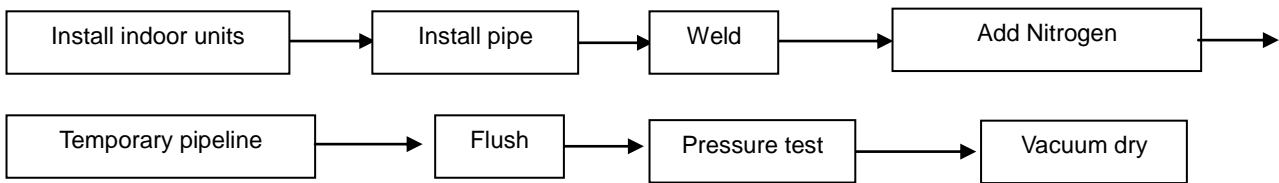

1.4 Drainage pipe

Procedure:

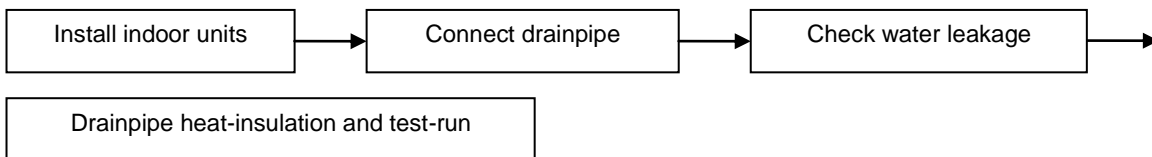

Note: It is no need to insulate the drainpipe if you choose the plastic pipe as drainpipe.

1.5 Electric wiring

- (1) Please select power supply for indoor unit and outdoor unit separately. Both indoor units and outdoor units should be grounded well.
- (2) The power supply should have specified branch circuit with leakage protector and manual switch.
- (3) Please put the connective wiring system between indoor unit and outdoor unit with refrigerant piping system together.
- (4) Power wiring should be done by professional electrician and complied with relevant National Electric Standard.
- (5) The power supply, leakage protector and manual of all the indoor units connecting to the same outdoor unit should be universal. (Please set all the indoor unit power supply of one system into the same circuit.)
- (6) It is suggested to use 3-core shielded wire as signal wire between indoor and outdoor units, multi-core wire is unavailable. Pay attention to the consistency. When signal wire parallel to the power wire, please keep enough distance (about 300mm at least) to prevent interference.
- (7) The power wire and signal wire can't be enlaced together.

1.6 Lay the indoor pipeline

Note:

Collocate the air-outlet reasonably to prevent airflow short-circuit. Check the static pressure whether in the allowable range. The air filters should be easy to unpick and wash. Do pressure test on pipeline.

1.7 Heat-insulation

Procedure:

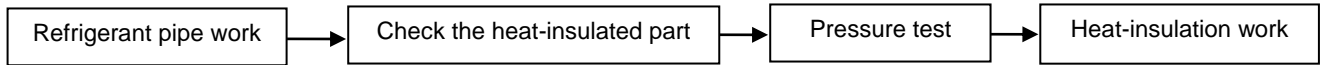

Note: For welding part, flare part and branch pipe, heat-insulation work must be done after finished the pressure test.

1.8 Install outdoor unit

Note:

- (1) Gutter must be set around the foundation to drain the condensation water.
- (2) When installing outdoor units at the roof, please check the strength of the roof and pay attention not to destroy the waterproof of the roof.

1.9 Recharge refrigerant

Procedure:

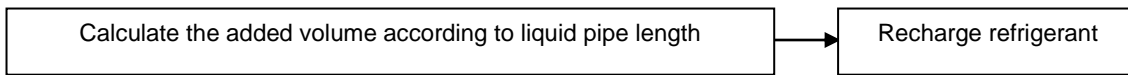

Note: Please calculate the additional amount of refrigerant according to the formula that we supply to you, and the calculation result must be correct

1.10 Main points of test running and debugging

Please check the following issues before turning on the power:

- (1). Vacuum dry:
Make sure the vacuum degree accord with our requirement about 10⁻⁵.
- (2). Wiring:
Includes the power wiring and communication wiring; Recheck the connection according to our corresponding wire diagrams. Especially, please remember our communication wire is polar; it means you must connect the communication wire correspondingly to the terminal block.
- (3). Additional charge of refrigerant:
Recheck the calculation formula and recalculate the total recharge volume according to our supplied formula.
- (4). Open the stop-valve of gas and liquid pipe with Allen key; Check leakage of stop-valve with soap water.

Please confirm whether the outdoor unit has been connected to the power for 12hr before start test running.

Test running:

Turn on all of the indoor units with cooling mode and set the temperature in 17degree with high fan speed first, after the system operated, test following operation parameters of the system, including indoor units and outdoor units parameters.

2.Installation of Indoor Unit

2.1 Hanging and Transportation

Please refer to Indoor unit Installation Manual.

2.2 Required Installation Place

Cassette Type

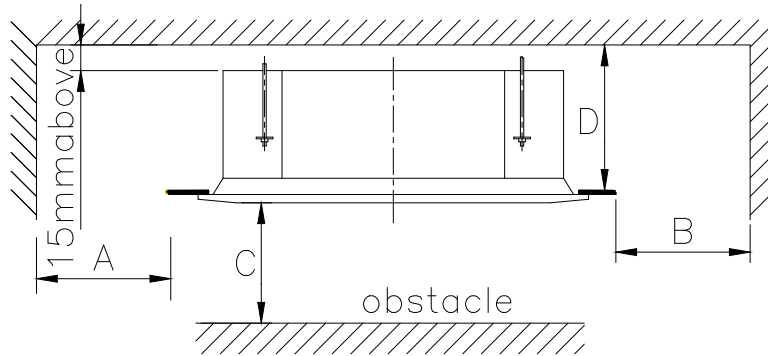

Type	A	B	C
One-way Cassette	1000mm above		
Four-way Cassette	1000mm above		2300mm above

2.2.1 Duct Type

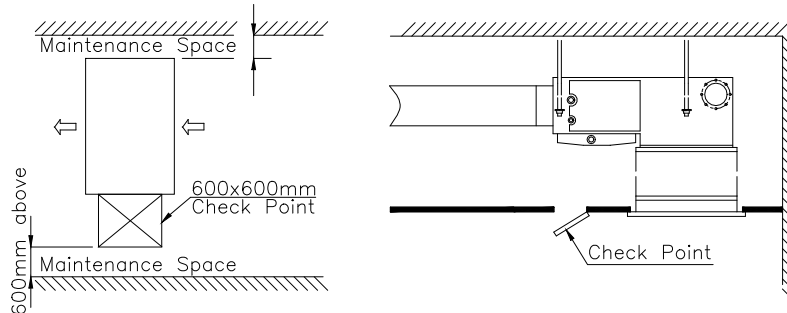

2.2.2 Wall Mounted Type

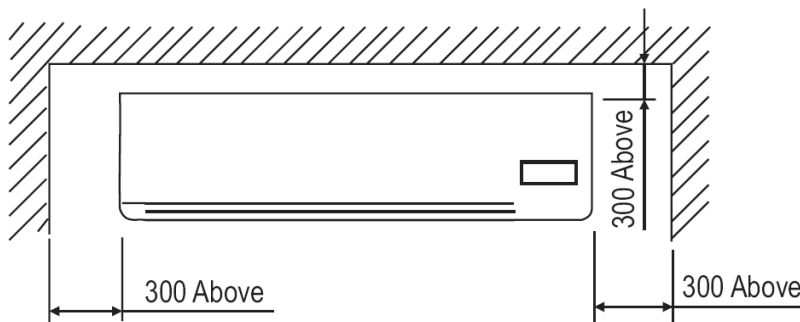

2.2.3 Ceiling and floor

Wall mounting installation:

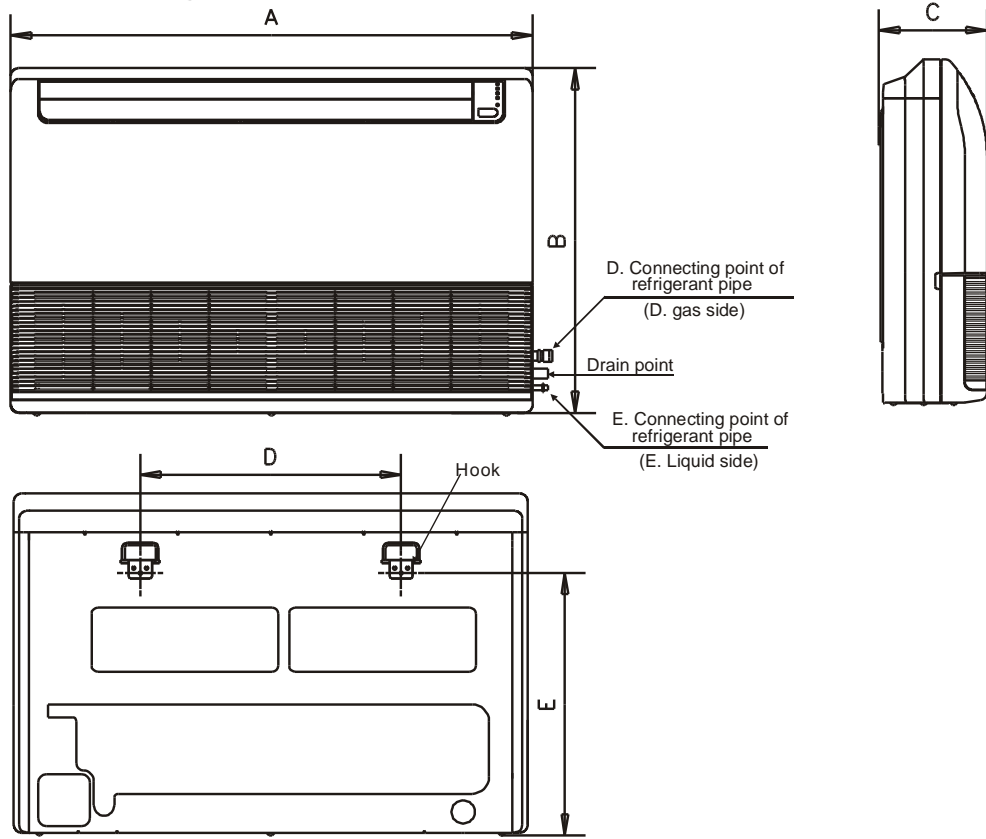

2.2.4 Ceiling installation:

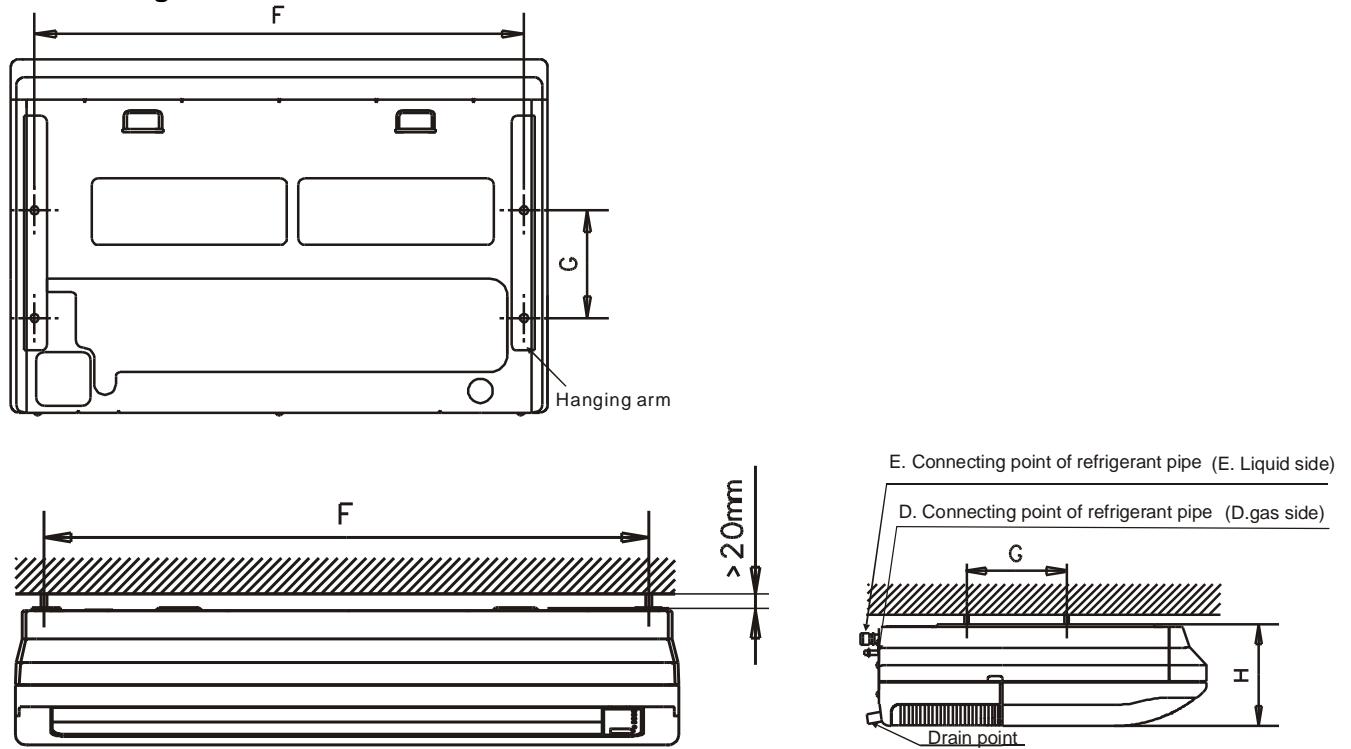

Capacity (W)	A	B	C	D	E	F	G	H
3600-7100	990	660	206	505	506	907	200	203
8000-10500	1280	660	206	795	506	1195	200	203
14000-16000	1670	680	244	1070	450	1542	200	240

3. Installation of Outdoor Unit

3.1 Installation place

Please keep away from the following place, or malfunction of the machine may be caused:

- There is combustible gas leakage.
- There is much oil (including engine oil) ingredient.
- There is salty air surrounding (near the coast)
- There is caustic gas (the sulfide, for example) existing in the air (near a hot spring)
- A place the heat air expelled out from the outdoor unit can reach your neighbor's window.
- A place that the noise interferes your neighbors every day life
- A place that is too weak to bear the weight of the unit
- Uneven place.
- Insufficient ventilation place.
- Near a private power station or high Frequency equipment.
- Install indoor unit, outdoor unit, power cord and connecting wire at least 1m away from TV set or radio to prevent noise or Install indoor unit, outdoor unit, power cord and connecting wire at least 1m away from TV set or radio to prevent noise or

The insulation of the metal parts of the building and the air conditioner should comply with the regulation of National Electric Standard.

CAUTION

Keep indoor unit, outdoor unit, power supply wiring and transmission wiring at least 1 meter away from televisions and radios. This is to prevent image interference and noise in those electrical appliances. (Noise may be generated depending on the conditions under which the electric wave is generated, even if 1 meter is kept.)

3.2 Installation space

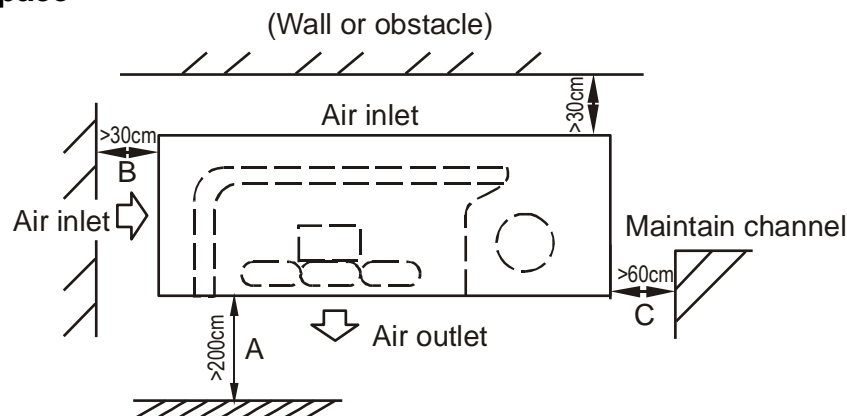

3.3 Moving and installation

- Since the gravity center of the unit is not at its physical center, so please be careful when lifting it with a sling.
- Never hold the inlet of the outdoor unit to prevent it from deforming.
- Do not touch the fan with hands or other objects.
- Do not lean it more than 45°, and do not lay it sidelong.
- Make concrete foundation according to the specifications of the outdoor units. (refer to Fig.5-4)
- Fasten the feet of this unit with bolts firmly to prevent it from collapsing in case of earthquake or strong wind. (refer to Fig.5-4)

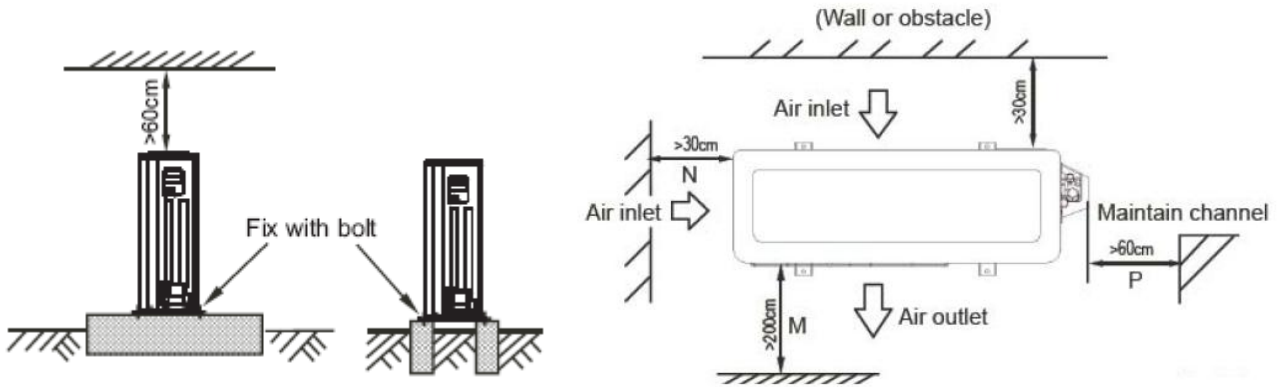

NOTE

All the pictures in this manual are for explanation purpose only. They may be slightly different from the air conditioner you purchased (depend on model).The actual shape shall Prevail.

4.Installation of Refrigerant Pipe

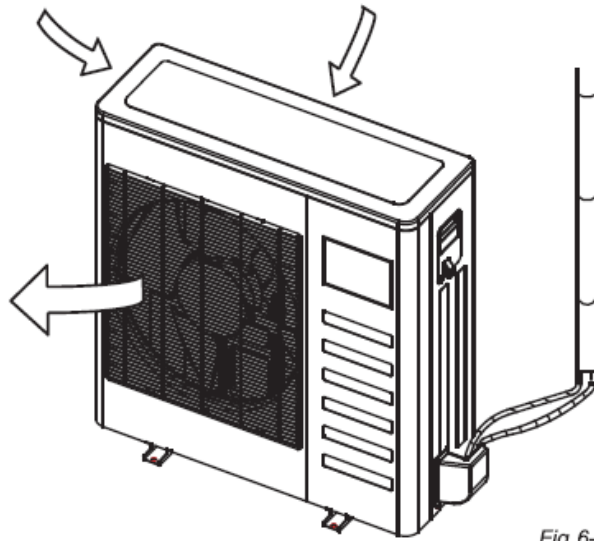
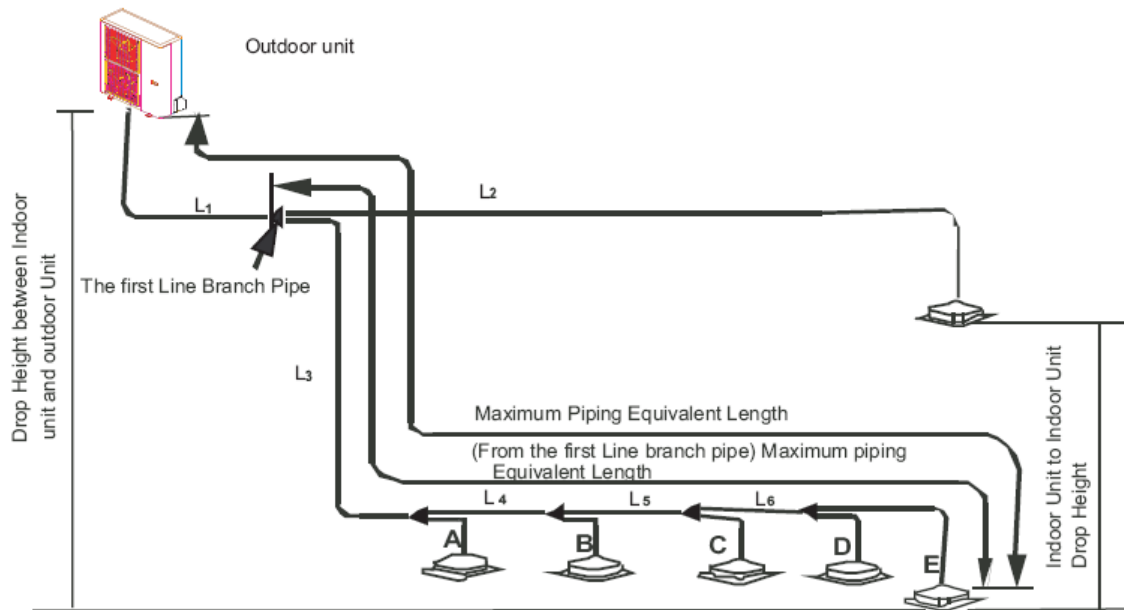

Fig.6-1

CAUTION

To prevent the refrigerant piping from oxidizing inside when welding, it is necessary to charge nitrogen, or oxide will chock the circulation system.

4.1 Length and Drop Height Permitted of the Refrigerant piping



			Permitted value	Piping
Pipe Length	Total Pipe Length (Actual)		≤100m	L1+L2+L3+L4+L5+L6 +A+B+C+D+E
	Maximum Piping(L)	Actual Length	≤45m	L1+L2+L3+L4+L5+L6+E
		Equivalent Length	≤50m	L3+L4+L5+L6+E
	Pipe length (from the first line branch to farthest indoor unit)		≤20m	/
Drop Height	Indoor Unit outdoor unit Drop Height	Outdoor Unit Up	20m	/
		Outdoor Unit Down	20m	/
	Indoor Unit to Indoor Unit Drop Height		8m	/

Note: Conversion of the equivalent length: Convert into the direct pipe length according to branch Junction 0.5m/l

4.2 Pipe size selection

4.2.1 Selection of the refrigerant pipe

Type of the pipe	Connecting part	No.
Main pipe	Between outdoor branch joint and first branch joint	1
Indoor main pipe	Between indoor branch joint	2
Indoor pipe	Between branch part and indoor unit	3

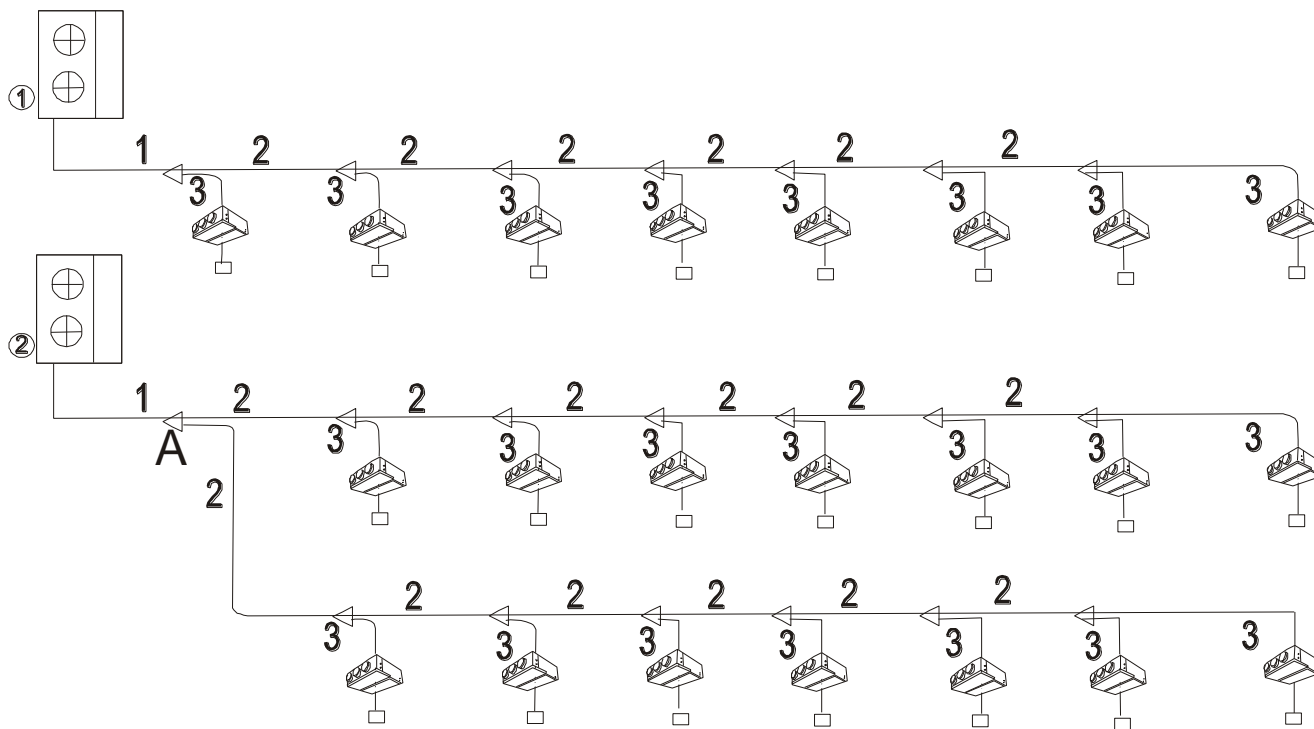

4.2.2 How to choose the Branch part and the refrigerant pipe?

According the total capacity of outdoor units to select the dimension of main pipe 1:

Refrigerant	Capacity of outdoor unit (kW)	Gas side	Liquid side
R410A	80	Φ15.9	Φ9.5
	10.5	Φ15.9	Φ9.5
	14	Φ15.9	Φ9.5
	16	Φ15.9	Φ9.5
Remarks	A converter pipe is needed for the connection between first branch joint and outdoor unit.		

Notes: Branch header must be connected with indoor units directly, the further branch connection is not allowed.

4.2.3 The maximum connection of indoor units:

Capacity of outdoor unit (kW)	Maximum Quantity of Indoor unit	Sum capacity of indoor unit (kW)
80	4	2.2~10
10.5	5	5.0~13.0
14	6	7.0~16.8
16	7	7.0~19.2

4.2.4 According the capacity of indoor units to select indoor main pipe 2 , main pipe 1 and branch joint:

Indoor main pipe dimension			
The total capacity of indoor units A	Gas Side(mm)	Liquid Side(mm)	The model of branch

			joint for indoor units
$A \leq 16.6kW$	$\Phi 19.1$	$\Phi 9.5$	FQZHN-01C
$16.6 \leq A \leq 230$	$\Phi 22.2$	$\Phi 9.5$	FQZHN-02C

4.2.5 Select the indoor pipe 3:

A: the total capacity and the gas side/liquid side pipe of indoor units

Pipe diameter (R410A)		
Indoor unit capacity (×100W)	Liquid pipe (mm)	Gas pipe (mm)
≤45	Φ6.4	Φ12.7
≥56	Φ9.5	Φ15.9

4.2.6 Modification main pipe 1:

According to the 4.2.2 and step 4.2.4 of calculation result, If the main pipe dimension according to outdoor capacity selection result are different from indoor capacity selection result, so the main pipe dimension you should selection bigger pipe.

4.2.7 Connecting method

3,4,5 HP Outdoor unit	Gas side	Liquid side
	Flaring nut	Flaring nut

4.2.8 The dimension of branch part

Branch list

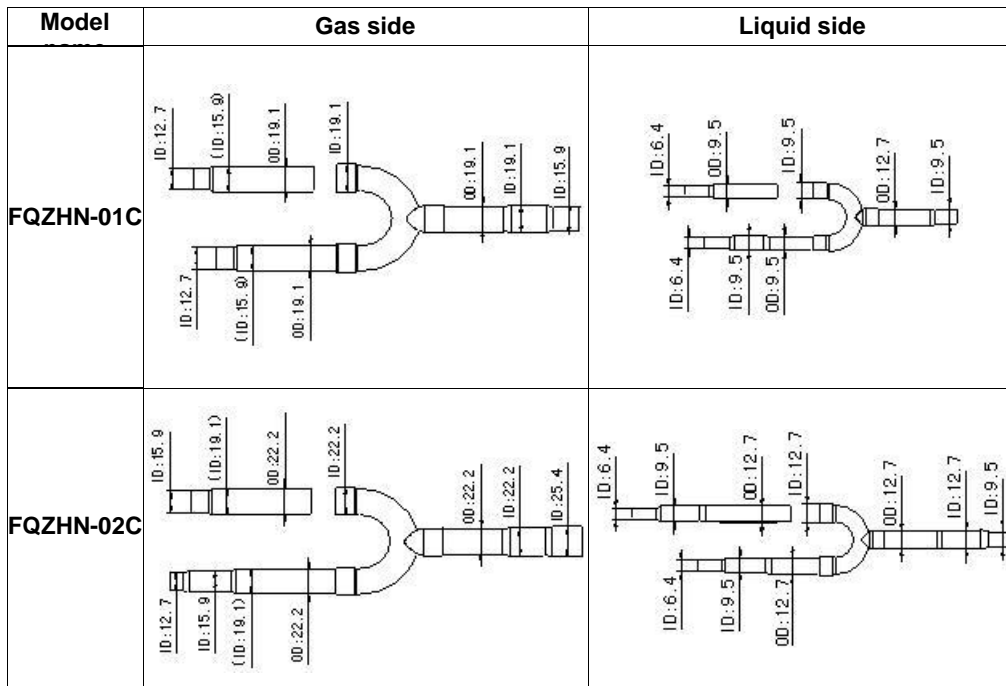

4.3 Refrigerant Amount to be added

Calculate the added refrigerant according to the diameter and the length of the liquid side pipe of the outdoor unit/indoor unit connection.

Table 6-8

Liquid Side Piping Diameter	Refrigerant to be added Per meter Piping
Φ6.4	0.022kg
Φ9.5	0.060kg
Φ12.7	0.110kg
Φ15.9	0.190kg
Φ19.1	0.290kg
Φ22.2	0.380kg

NOTE:

Additional refrigerant volume of branch pipe is 0.1kg per item (Consider the liquid side of branch pipe only)

5.Processing & Installation of Drainage Pipe

5.1 Gradients and Supporting

- 5.1.1 Keep the drainpipe sloping downwards at a gradient of at least 1/100. Keep the drainpipe as short as possible and eliminate the air bubble.
- 5.1.2 The horizontal drainpipe should be short. When the pipe is too long, a prop stand must be installed to keep the gradient of 1/100 and prevent bending. Refer to the following table for the specification of the prop stand.

	Diameter	Distance between the prop stands
Hard PVC pipe	25~40mm	1.5~2m

Precautions

- The diameter of drainpipe should meet the drainage requirement at least.
- The drainpipe should be heat-insulated to prevent atomization.
- Drainpipe should be installed before installing indoor unit. After powering on, there is some water in water-receiver plate. Please check if the drain pump can act correctly.
- All connection should be firm.
- Wipe color on PVC pipe to note connection.
- Climbing, horizontal and bending conditions are prohibited.
- The dimension of drainpipe can't less than the connecting dimension of indoor drainpipe.
- Heat-insulation should be done well to prevent condensation.
- Indoor units with different drainage type can't share one convergent drainpipe.

5.2 Drainpipe Trap

- 5.2.1 If the pressure at the connection of the drainpipe is negative, it needs to design drainpipe trap.
- 5.2.2 Every indoor unit needs one drainpipe trap.
- 5.2.3 A plug should be designed to do cleaning.

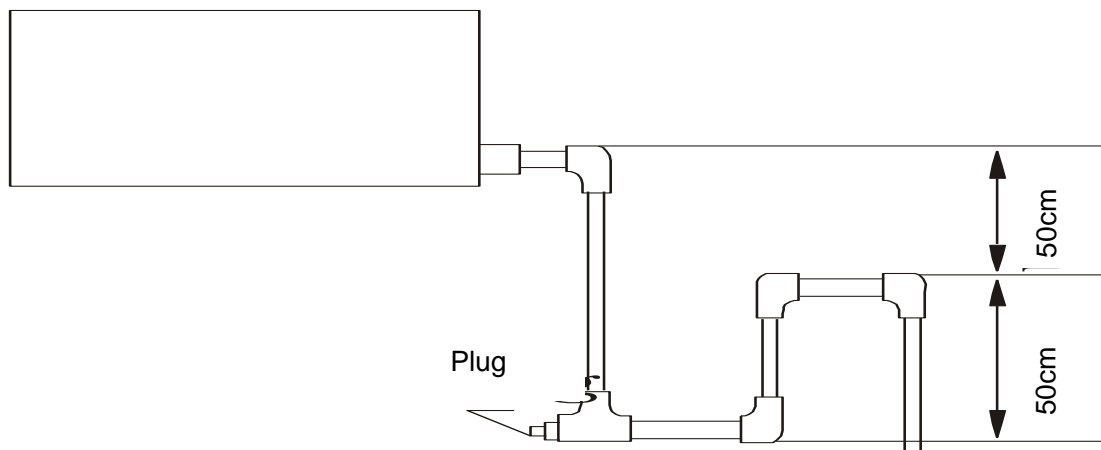

5.3 Upward drainage (drain pump)

5.3.1 For Four-way cassette(compact)

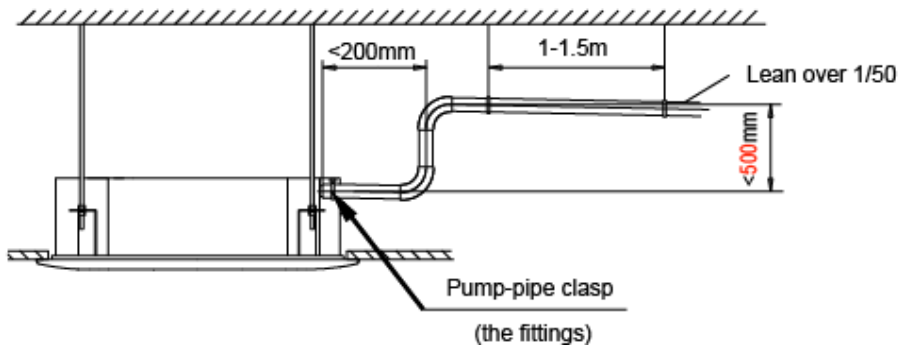

5.3.1 For Four-way cassette

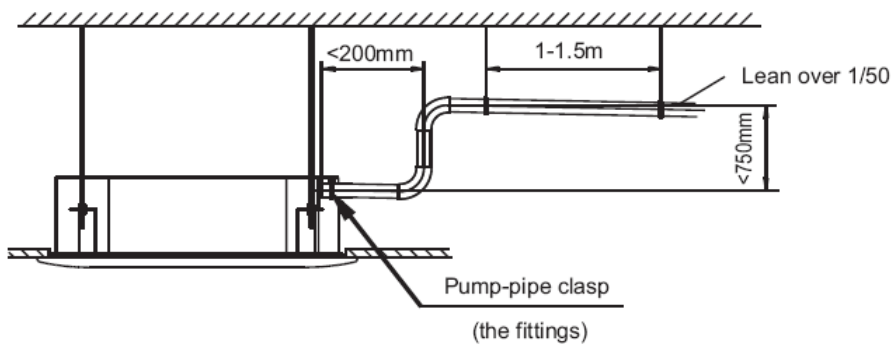

5.4 Convergent drainage

5.4.1 The number of indoor units should be as small as possible to prevent the traverse main pipe overlong.

5.4.2 Indoor unit with drain pump and indoor unit without drain pump should be in different drainage system.

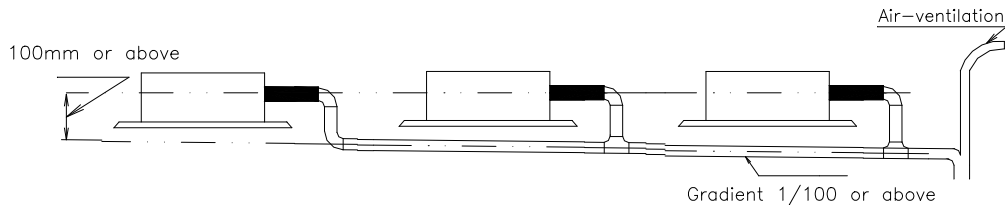

Selection the diameter

Number of connecting indoor units → Calculate drainage volume → Select the diameter

Calculate allowed volume = Total cooling capacity of indoor units (HP) × 2 (l/ hr)

	Allowed volume(lean 1/100) (l/ hr)	I.D. (mm)	Thick
Hard PVC	≤ 14	Φ25	3.0
Hard PVC	$14 < \leq 88$	Φ30	3.5
Hard PVC	$88 < \leq 334$	Φ40	4.0
Hard PVC	$175 < \leq 334$	Φ50	4.5
Hard PVC	$334 < \leq$	Φ80	6.0

5.5 Drainage test

5.5.1 Drainage without drain pump

After finishing drainpipe installation, pour some water into the water plate to check if the water flows smoothly.

5.5.2 Drainage with drain pump

5.5.2.1 Poke the Water Level Switch, remove the cover, and use water pipe to pour 2000ml water into the water plate through the water inlet.

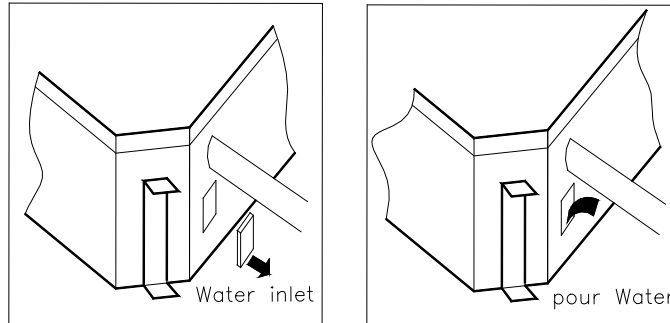

5.5.2.2 Turn on the power to cooling operation. Check the pump's operation and switch on the Water Level Switch. Check the pump's sound and look into the transparent hard pipe in the outlet at the same time to check if the water can discharge normally.

5.5.2.3 Stop the air conditioner running, turn off the power, and put back the cover.

- Stop the air conditioner. After 3 minutes, check if it has abnormality. If the collocation of drainpipes is illogical, the water will flow back overfull, which will cause the alarm lamp flashes, even circumfluence from the water plate.
- Keep on pouring water until it gives an alarm signal for high water level, check if the pump drains water at once. If the water level can't fall below the alarmed water level after 3 minutes, the air conditioner will stop (means this indoor unit stops, stand-by, but the outdoor unit still work if there is capacity requirement). Turn off the power and drain the remained water, then turn on the air conditioner.

Note:

the drain stopper in the main water plate is for maintenance. Stuff up the drain stopper to prevent water leakage.

6. Insulation Work

6.1 Insulation material and thickness

6.1.1 Insulation material

Insulation material should adopt the material, which is able to endure the pipe's temperature: no less than 70°C in the high-pressure side, no less than 120°C in the low-pressure side (For the cooling type machine, no requirements at the low-pressure side.)

Example: Heat pump type----Heat-resistant Polyethylene foam (withstand above 120°C)

Cooling only type---- Polyethylene foam (withstand above 100°C)

Thickness choice for insulation material

Insulation material thickness is as follows:

	Pipe diameter (mm)	Adiabatic material thickness
Refrigerant pipe	Φ6.4—Φ25.4	10mm
	Φ28.6—Φ38.0	15mm
	Φ38.0—Φ67.0	20mm
Drainage pipe	Inner diameterΦ20—Φ32	6mm

6.2 Refrigerant pipe insulation

6.2.1 Work Procedure

- Before laying the pipes, the non-jointing parts and non-connection parts should be heat insulated.
- After the gas proof test is eligible, the jointing area, expanding area and the flange area should be heat insulated

Insulation for non-jointing parts and non-connection parts

Wrong	Right	
Gas pipe and liquid pipe should not be put together to insulate	Insulate the gas pipe (Cooling only)	Insulate the gas pipe and the liquid pipe

For construction convenience, before laying pipes, use insulation material to insulate the pipes to be deal with, at the same time, at two tips of the pipe, remain some length not to be insulated, in order to be welded and check the leakage after laying the pipes.

Insulate for the jointing area, expanding area and the flange area

- Insulate for the jointing area, expanding area and the flange area should be done after checking leakage of the pipes
- Make sure there's no clearance in the joining part of the accessorial insulation material and local preparative insulation material.

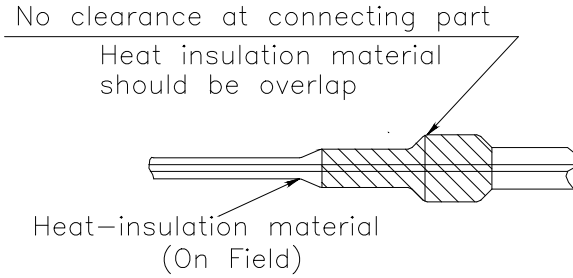

Enswathe disposal

After insulation of the pipes, do the enswathe disposal with binding belt, make sure it's tight.

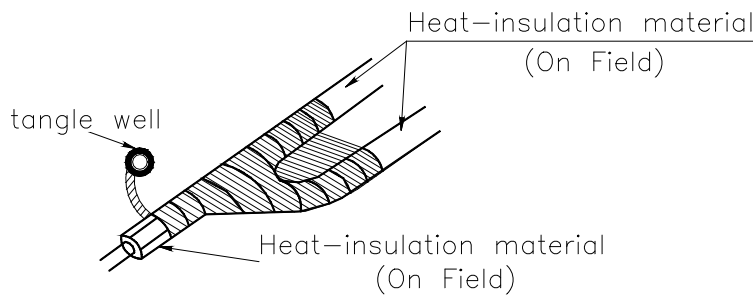

Drainage pipe insulation

The connection part should be insulated, or else water will be condensing at the non-insulation part.

6.4 Note

- 6.4.1 The jointing area, expanding area and the flange area should be heat insulated after passing the pressure test
- 6.4.2 The gas and liquid pipe should be heat insulated individually, the connecting part should be heat insulated individually.
- 6.4.3 Use the attached heat-insulation material to insulate the pipe connections (pipes' tie-in ,expand nut) of the indoor unit.

7. Electric Installation

CAUTION

- Please select power source for indoor unit and outdoor unit respectively
- The power supply has specified branch circuit with leakage protector and manual switch.
- Indoor unit connect with power supply which is 220-240V~50Hz. Outdoor unit connect with power supply which is 380-415V~50Hz (Please set all the indoor unit power of one system into the same branch circuit.)
- Please put the connective wire system between indoor unit and outdoor unit with the refrigerant system together.
- Use 3-core screened wire as indoor and outdoor control wire.
- The installation should comply with relevant national electric standard.
- Power wiring should be engaged by specialized electrician.

7.1 Outdoor Unit Wiring

The Specification of Power

Table 7-1

Capacity Kw		10.5-16.0
Outdoor Unit power	Phase	3 phase
	Frequency and Voltage	380-415V~ 50Hz
	Power Wiring(mm ²)	5-core X 2.5
Circuit Breaker		30
Indoor unit/Outdoor unit Signal wire (Weak electric signal) (mm ²)		3-core shielded wire 3X0.5

Capacity Kw		80	10.5	10.5-B	14
Outdoor Unit power	Phase	1 phase			
	Frequency and Voltage	220-240V~ 50Hz			
	Power Wiring(mm ²)	3-core X 4			
Circuit Breaker		50	80	50	80
Indoor unit/Outdoor unit Signal wire (Weak electric signal) (mm ²)		3-core shielded wire 3X0.5			

CAUTION

A disconnection device having an air gap contact separation in all active conductors should be incorporated in the fixed wiring according to the National Wiring Regulation.

For 10.5kW-16.0kW (3-phase)

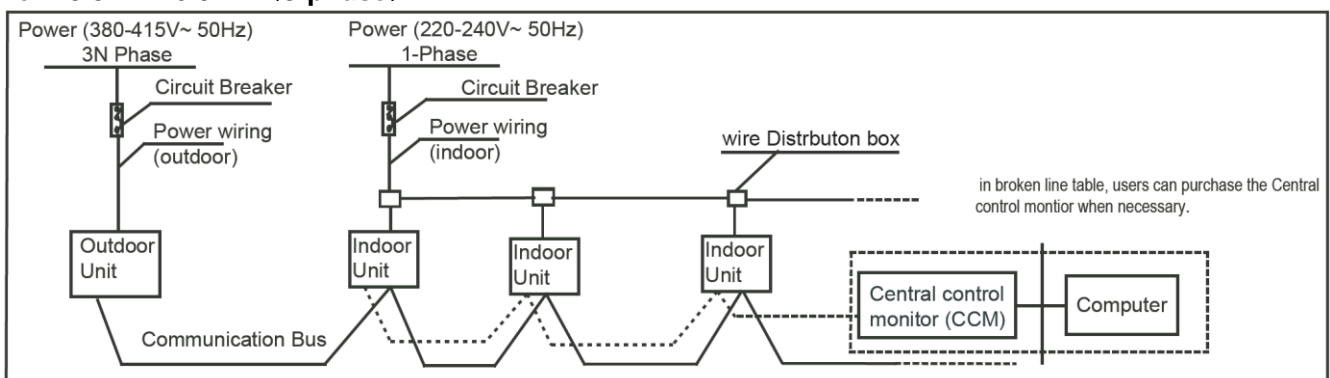

For 8kW-14kW (1-phase)

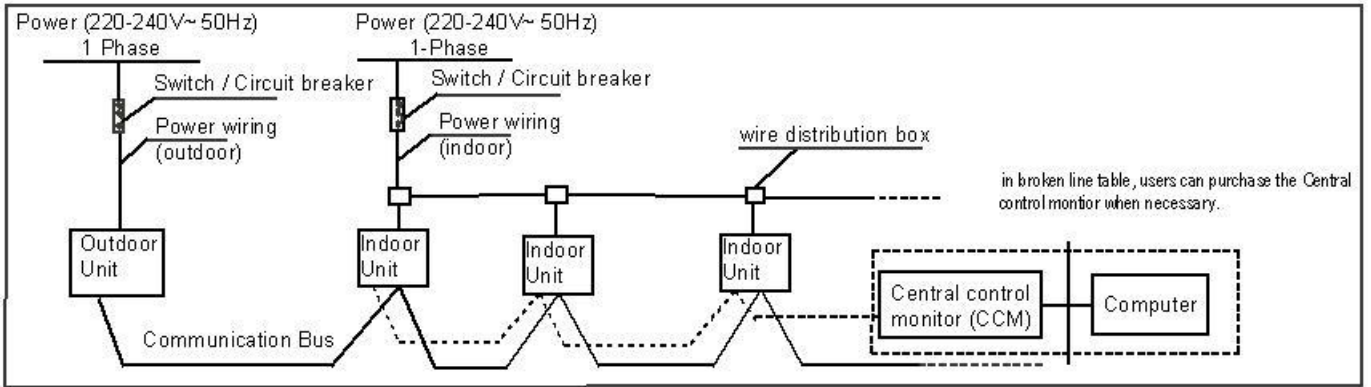
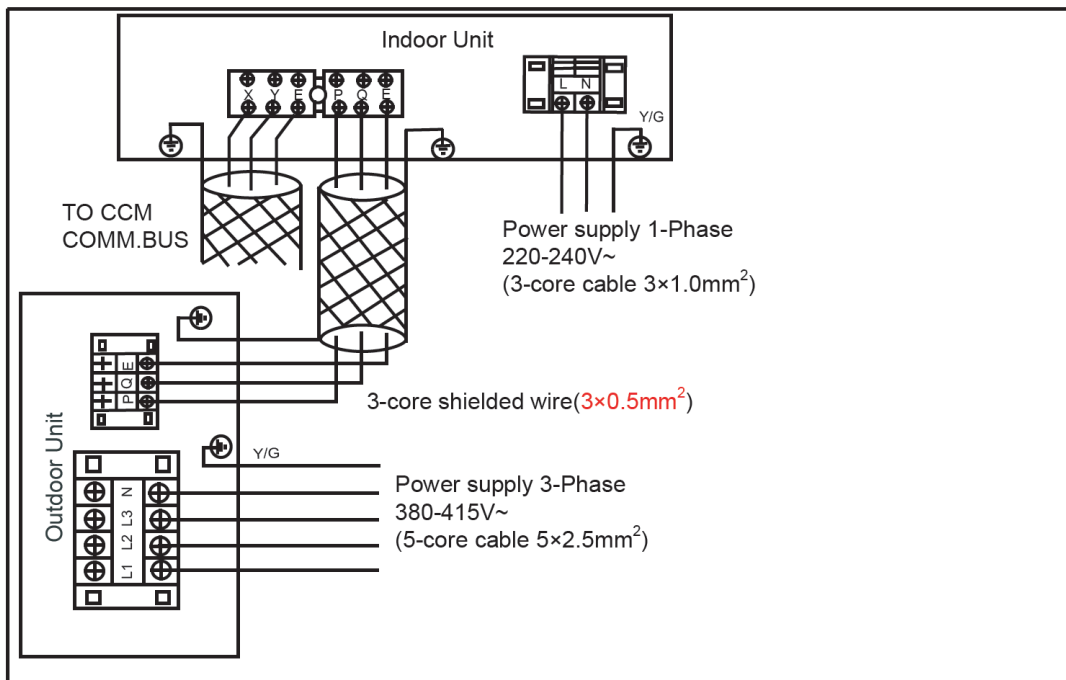

Fig.7-1

Power supply for 3- phase



Power supply for 1- phase

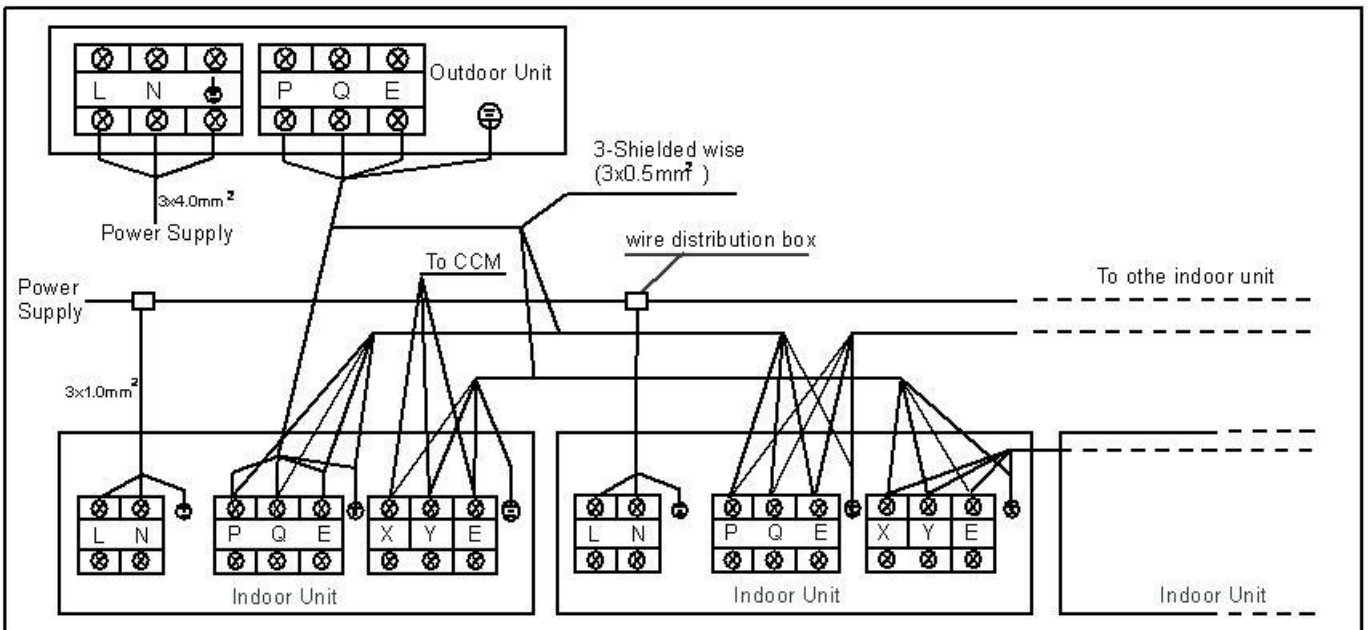

Fig.7-2

CAUTION

The reserved function is indicated in broken line table, users can select it when necessary.

Indoor/Outdoor Unit Signal Wire

Connect the wire according to their numbers.
Wrong connection may cause malfunction.

Wiring Connection

Seal the wiring connection with the insulation material, or the condensing dew will be caused.

NOTE

The air-conditioners can connect with Central Control Monitor (CCM). Before operation, please wiring correctly and set system
the air-conditioners can connect with Central Control Monitor (CCM). Before operation, please wiring correctly and set system

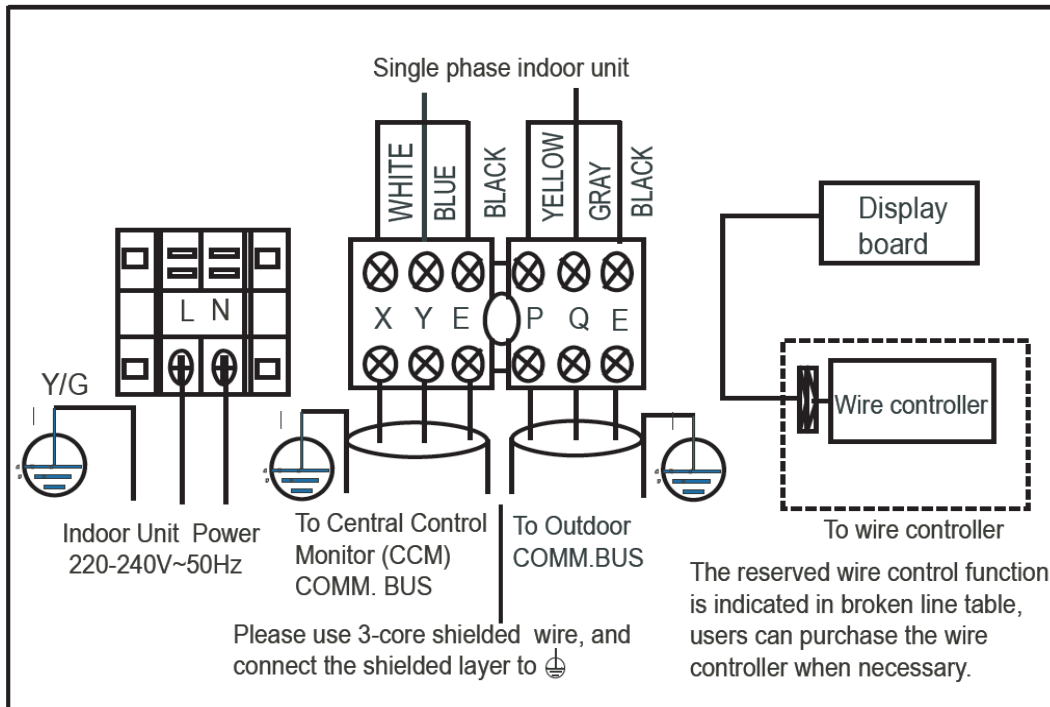

Fig.7-3

7.2 Indoor Unit Wiring

Power Supply

Table 7-2

Capacity (Btu/h)		36000~60000
indoor Unit power	Phase	1- phase
	Frequency and Voltage	220-240V~ 50Hz
	Power Wiring(mm²)	3-corex1.0
Circuit Breaker/Fuse (A)		15/15
Indoor unit/Outdoor unit Signal wire (Weak electric signal) (mm²)		3-core shielded wire 3X0.5

- 1.Signal wire is 3-core, polarized wire. Use 3-core shield wire to prevent interference. The grounding method now is grounding the closed end of the shield wire and opening (insulating) at the end. Shield is to be grounded.
- 2.The control between outdoor unit and indoor unit is BUS type. An address is set on field during the installation.

CAUTION

The wire diameter and continuous length is under the condition that the voltage vibration is within 2%. If the continuous length is exceed showing value, choose the wire diameter follow relevant regulation.

Indoor unit power supply wiring

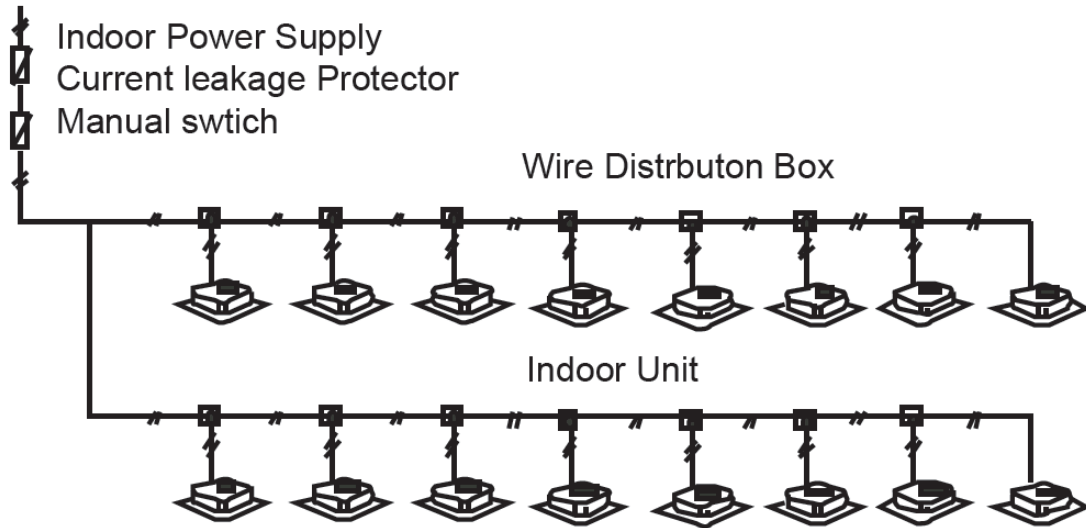

Fig.7-3

CAUTION

- 1. Refrigerant piping system, indoor unit-indoor unit connection signal wires and indoor unit-outdoor unit connection signal wire are in the same system.
- 2. When power cord is parallel with signal wire, please put them into separate wire distribution pipes, and leave a proper distance. (Reference distance: It is 300mm when current capacity of power cord is less than 10A, or 500mm when 50A).
Please use shield wire as indoor unit/outdoor unit signal wire.

Indoor/Outdoor unit signal wire wiring

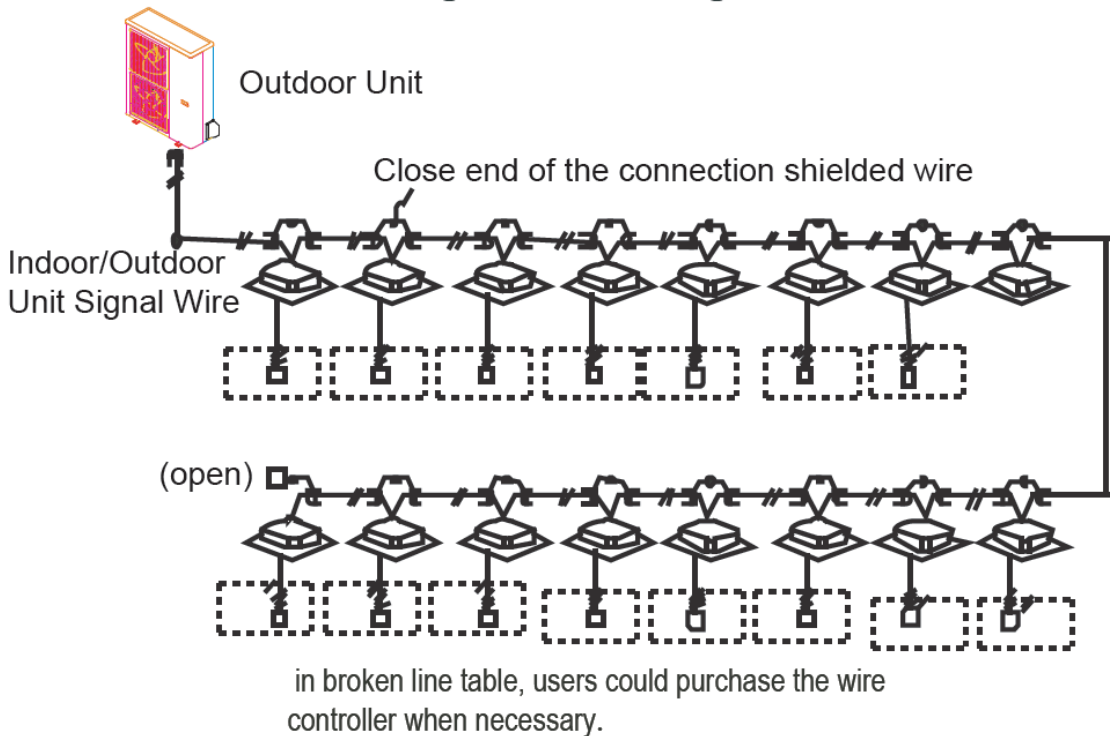

Fig.7-4

8. Test Running

Operate according to “gist for test running” on the electric control box cover.

CAUTION

- Test running can not start until the outdoor unit has been connected to the power for 12hr.
- Test running can not start until all the valves are affirmed open.
- Never make the forced running. (Or the protector sits back, danger will occur.)

9. Precautions on Refrigerant Leakage

This air conditioner (A/C) adopts innocuous and nonflammable refrigerant. The locating room of the A/C should be big enough that any refrigerant leakage is unable to reach critical thickness. So certain essential action can be taken on time.

Refrigerant critical thickness: 0.44[kg/m] for R410A.

Confirm the critical thickness through follow steps, and take necessary actions.

1. Calculate the sum of the charge volume (A[kg]) Total Refrigerant volume of 10HP=factory refrigerant volume + superaddition
2. Calculate the indoor cubage (B[m]) (as the minimum cubage).
3. Calculate the refrigerant thickness

$$\frac{A[\text{kg}]}{B[\text{m}^3]} \leq \text{critical thickness}$$

Counter measure against over high thickness

1. Install mechanical ventilator to reduce the refrigerant thickness under critical level. (ventilate regularly)
2. Install leak alarm facility related to mechanical ventilator if you can not regularly ventilate.

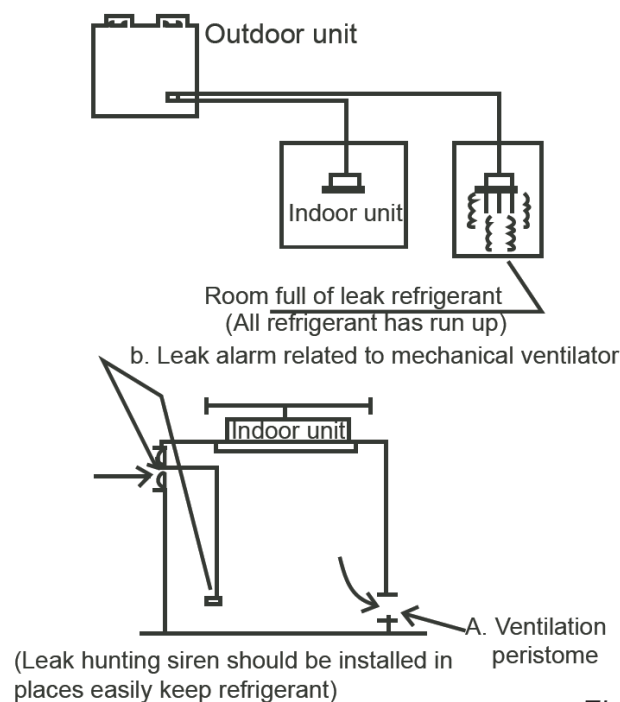

NOTE

Please press "constraint cool" button to carry out refrigerant recycling process. Keep the low pressure above 0.2MPa; otherwise compressor may be burnt out.