



**MDV**  
H V A C SYSTEMS

# **SERVICE MANUAL**

**MDV AIRCONDITIONER**  
**DC INVERTER**  
**SPLIT WALL-MOUNTED TYPE**

*MS9Vi-18HRDN1-QC2*

# CONTENTS

<b>1. Precaution</b> .....	<b>1</b>
1.1 Safety Precaution.....	1
1.2 Warning.....	1
<b>2. Function</b> .....	<b>4</b>
<b>3. Dimension</b> .....	<b>6</b>
3.1 Indoor Unit.....	6
MS9Vi-18HRDN1-QC2 .....	6
3.2 Outdoor Unit.....	7
MOCi-18HDN1-QC2 .....	7
<b>4. Specification</b> .....	<b>8</b>
<b>5. Refrigerant cycle diagram</b> .....	<b>9</b>
<b>6. Wiring diagram</b> .....	<b>10</b>
6.1 Indoor Unit.....	10
MS9Vi-18HRDN1-QC2.....	10
6.2 Outdoor Unit.....	11
MOCi-18HDN1-QC2 .....	11
<b>7. Installation details</b> .....	<b>12</b>
7.1 Wrench torque sheet for installation.....	12
7.2 Connecting the cables.....	12
7.3 Pipe length and the elevation.....	12
7.4 Air purging of the piping and indoor unit.....	12
7.5 Pumping down (Re-installation).....	14
7.6 Re-air purging (Re-installation).....	15
7.7 Balance refrigerant of the 2-way, 3-way valves.....	16
7.8 Evacuation.....	17
7.9 Gas charging.....	18
<b>8. Operation characteristics</b> .....	<b>20</b>
<b>9. Electronic function</b> .....	<b>22</b>
9.1 Abbreviation.....	22
9.2 Display function.....	22
9.3 Protection.....	22
9.4 Fan-Only Mode.....	23
9.5 Cooling Mode.....	24
9.6 Drying mode.....	25
9.7 Heating mode.....	25
9.8 Auto mode function.....	29
9.9 Forced operation function.....	30
9.10 Action of 4-way valve.....	30
9.11 Two speeds outdoor fan function.....	30
9.12 Timer function.....	30
9.13 Sleep function mode.....	31
9.14 Auto-Restart function.....	31

9.15 Ionizer function(optional).....	31
9.16 Outdoor chassis heating cable (optional).....	31
<b>10. Troubleshooting.....</b>	<b>32</b>
10.1 Indoor Unit Error Display.....	33
10.2 Diagnosis and Solution.....	34
10.3 Key parts checking.....	37

# 1. Precaution

## 1.1 Safety Precaution

- **To prevent injury to the user or other people and property damage, the following instructions must be followed.**
- **Incorrect operation due to ignoring instruction will cause harm or damage.**
- **Before service unit, be sure to read this service manual at first.**

## 1.2 Warning

### ➤ Installation

- **Do not use a defective or underrated circuit breaker. Use this appliance on a dedicated circuit.**

There is risk of fire or electric shock.

- **For electrical work, contact the dealer, seller, a qualified electrician, or an Authorized service center.**

Do not disassemble or repair the product, there is risk of fire or electric shock.

- **Always ground the product.**

There is risk of fire or electric shock.

- **Install the panel and the cover of control box securely.**

There is risk of fire of electric shock.

- **Always install a dedicated circuit and breaker.**

Improper wiring or installation may cause fore or electric shock.

- **Use the correctly rated breaker of fuse.**

There is risk of fire or electric shock.

- **Do not modify or extend the power cable.**

There is risk of fire or electric shock.

- **Do not install, remove, or reinstall the unit by yourself (customer).**

There is risk of fire, electric shock, explosion, or injury.

- **Be caution when unpacking and installing the product.**

Sharp edges could cause injury, be especially careful of the case edges and the fins on the condenser and evaporator.

- **For installation, always contact the dealer or an Authorized service center.**

There is risk of fire, electric shock, explosion, or injury.

- **Do not install the product on a defective installation stand.**

It may cause injury, accident, or damage to the product.

- **Be sure the installation area does not deteriorate with age.**

If the base collapses, the air conditioner could fall with it, causing property damage, product failure, and personal injury.

- **Do not let the air conditioner run for a long time when the humidity is very high and a door or a window is left open.**

Moisture may condense and wet or damage furniture.

- **Take care to ensure that power cable could not be pulled out or damaged during operation.**

There is risk of fire or electric shock.

- **Do not place anything on the power cable.**

There is risk of fire or electric shock.

- **Do not plug or unplug the power supply plug during operation.**

There is risk of fire or electric shock.

- **Do not touch (operation) the product with wet hands.**

There is risk of fire or electric shock.

- **Do not place a heater or other appliance near the power cable.**

There is risk of fire and electric shock.

- **Do not allow water to run into electric parts.**

It may cause fire, failure of the product, or electric shock.

- **Do not store or use flammable gas or**

**combustible near the product.**

There is risk of fire or failure of product.

■ **Do not use the product in a tightly closed space for a long time.**

Oxygen deficiency could occur.

■ **When flammable gas leaks, turn off the gas and open a window for ventilation before turn the product on.**

Do not use the telephone or turn switches on or off.

There is risk of explosion or fire.

■ **If strange sounds, or small or smoke comes from product. Turn the breaker off or disconnect the power supply cable.**

There is risk of electric shock or fire.

■ **Stop operation and close the window in storm or hurricane. If possible, remove the product from the window before the hurricane arrives.**

There is risk of property damage, failure of product, or electric shock.

■ **Do not open the inlet grill of the product during operation. (Do not touch the electrostatic filter, if the unit is so equipped.)**

There is risk of physical injury, electric shock, or product failure.

■ **When the product is soaked (flooded or submerged), contact an Authorized service center.**

There is risk of fire or electric shock.

■ **Be caution that water could not enter the product.**

There is risk of fire, electric shock, or product damage.

■ **Ventilate the product from time to time when operating it together with a stove, etc.**

There is risk of fire or electric shock.

■ **Turn the main power off when cleaning or maintaining the product.**

There is risk of electric shock.

■ **When the product is not be used for a long time, disconnect the power supply plug or turn off the breaker.**

There is risk of product damage or failure, or unintended operation.

■ **Take care to ensure that nobody could**

**step on or fall onto the outdoor unit.**

This could result in personal injury and product damage.

#### ➤ **CAUTION**

■ **Always check for gas (refrigerant) leakage after installation or repair of product.**

Low refrigerant levels may cause failure of product.

■ **Install the drain hose to ensure that water is drained away properly.**

A bad connection may cause water leakage.

■ **Keep level even when installing the product.**

To avoid vibration of water leakage.

■ **Do not install the product where the noise or hot air from the outdoor unit could damage the neighborhoods.**

It may cause a problem for your neighbors.

■ **Use two or more people to lift and transport the product.**

Avoid personal injury.

■ **Do not install the product where it will be exposed to sea wind (salt spray)**

It may cause corrosion on the product. Corrosion, particularly on the condenser and evaporator fins, could cause product malfunction or inefficient operation.

#### ➤ **Operational**

■ **Do not expose the skin directly to cool air for long periods of time. (Do not sit in the draft).**

This could harm to your health.

■ **Do not use the product for special purposes, such as preserving foods, works of art, etc. It is a consumer air conditioner, not a precision refrigerant system.**

There is risk of damage or loss of property.

■ **Do not block the inlet or outlet of air flow.**

It may cause product failure.

■ **Use a soft cloth to clean. Do not use harsh detergents, solvents, etc.**

There is risk of fire, electric shock, or damage to the plastic parts of the product.

■ **Do not touch the metal parts of the product when removing the air filter. They are very sharp.**

There is risk of personal injury.

■ **Do not step on or put anything on the product. (outdoor units)**

There is risk of personal injury and failure of product.

■ **Always insert the filter securely. Clean the filter every two weeks or more often if necessary.**

A dirty filter reduces the efficiency of the air conditioner and could cause product malfunction or damage.

■ **Do not insert hands or other object through air inlet or outlet while the product is operated.**

There are sharp and moving parts that could cause personal injury.

■ **Do not drink the water drained from the product.**

It is not sanitary could cause serious health issues.

■ **Use a firm stool or ladder when cleaning or maintaining the product.**

Be careful and avoid personal injury.

■ **Replace the all batteries in the remote control with new ones of the same type. Do not mix old and new batteries or different types of batteries.**

There is risk of fire or explosion.

■ **Do not recharge or disassemble the batteries. Do not dispose of battery in a fire.**

They may burn or explode.

■ **If the liquid from the batteries gets onto your skin or clothes, wash it well with clean water. Do not use the remote of the batteries have leaked.**

The chemical in batteries could cause burns or other health hazards

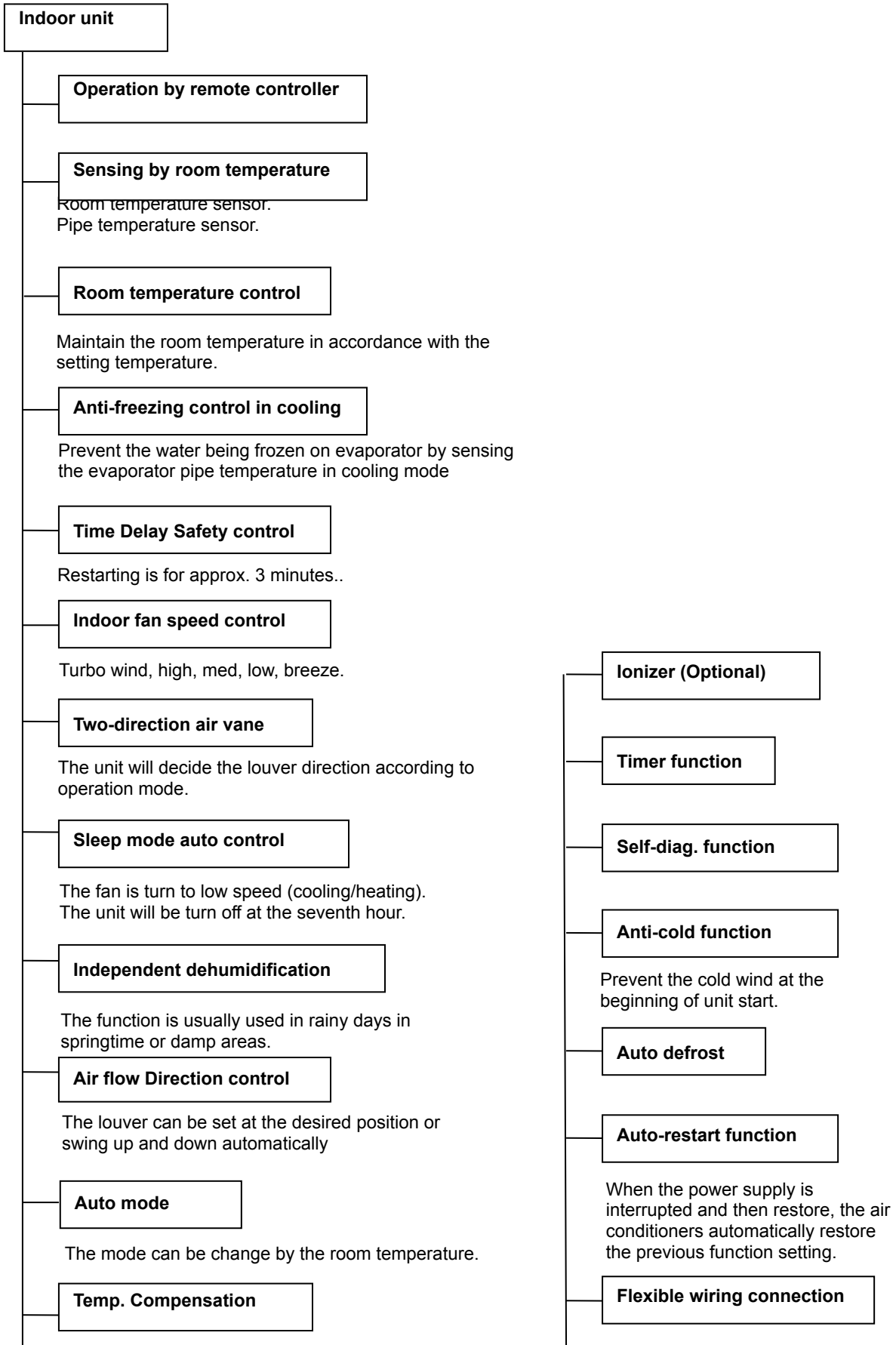

## Outdoor unit

### Power relay control

The unit has 3 mins delay between continuously ON/OFF operations.

### Low noise air flow system

Bird tail propeller fan makes the outdoor unit run more quietly.

### Hydrophilic aluminum fin

The hydrophilic fin can improve the heating efficiency at operation mode.

### 4 way valve control

It is only operated in the heating operation mode except defrosting operation.

### Anti-rust cabinet

Made from electrolytic zinc steel sheet and anti-rust coated components.

### Valve protection cover

It protects the valves and prevents water from dripping.

### Discharge pipe temperature protect

### Heating cable (Optional)

### Driving heating at -15℃



### 3. Dimension

#### 3.1 Indoor Unit

MS9Vi-18HRDN1-QC2

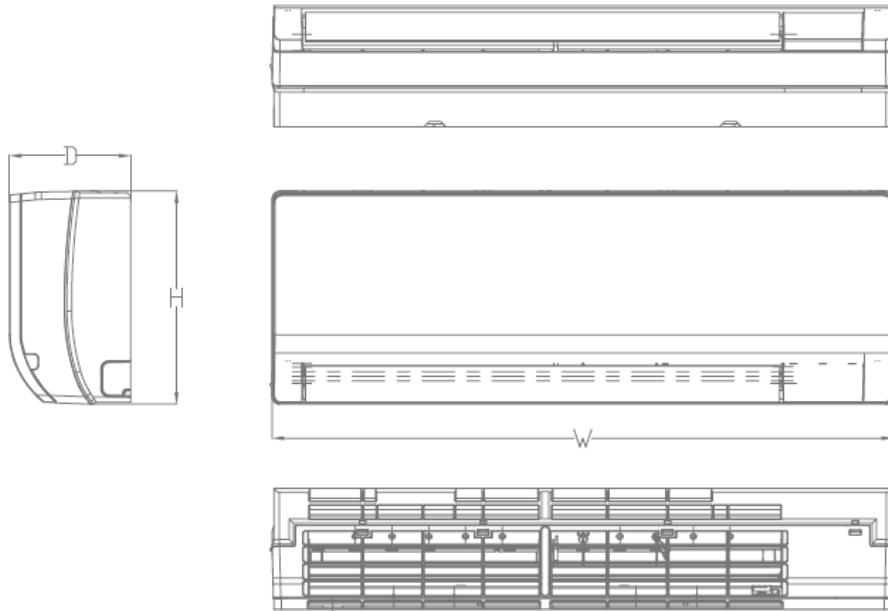

Model	W(mm)	H(mm)	D(mm)
MS9V-18HRDN1-QC2	995	290	200

### 3.2 Outdoor Unit

MOCi-18HDN1-QC2

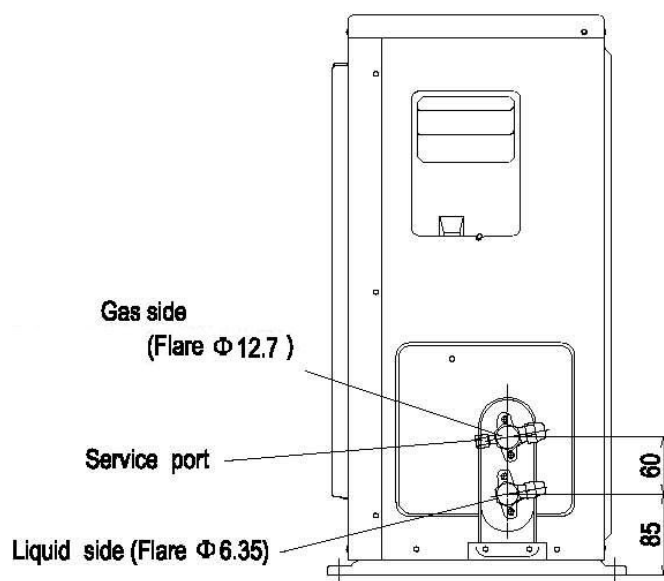
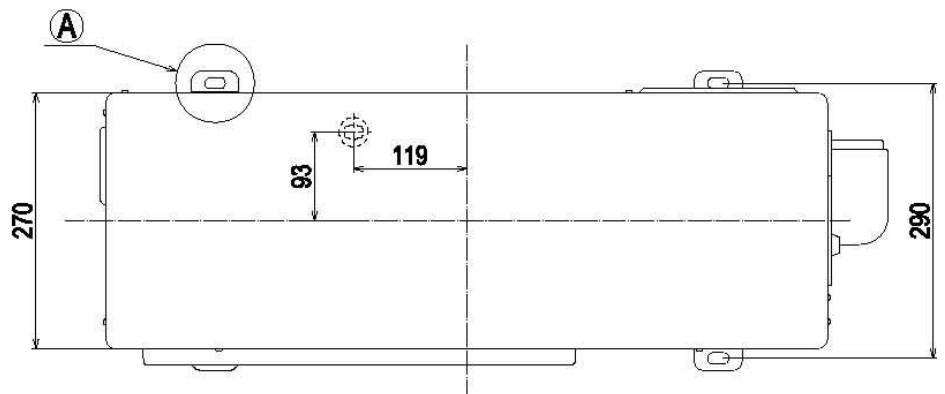
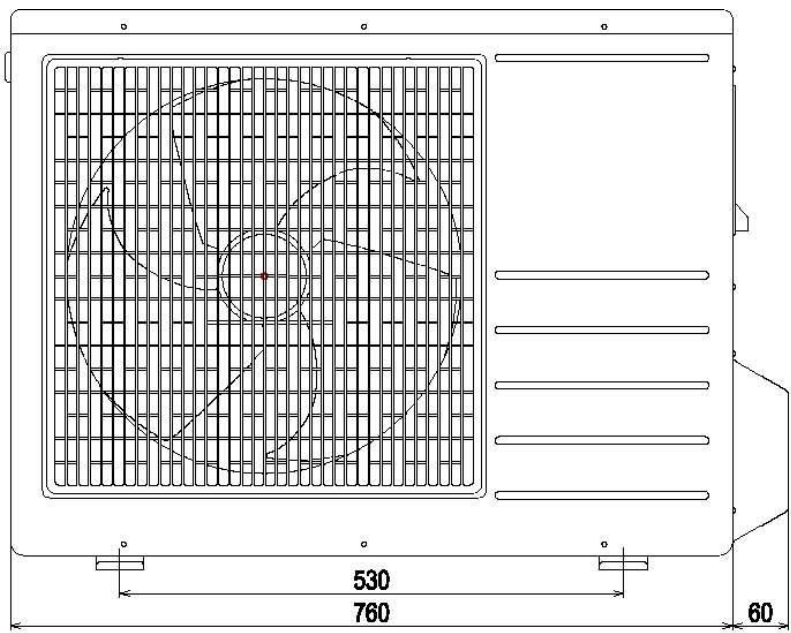
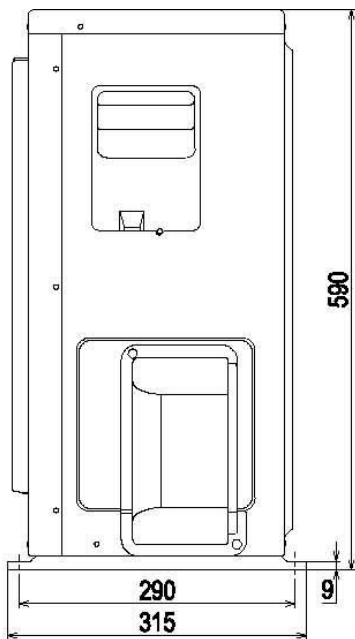

## 4. Specification

Indoor		MS9Vi-18HRDN1-QC2	
Outdoor		MOCi-18HDN1-QC2	
Power supply	Ph-V-Hz	1, 220-240V~, 50Hz	
Moisture Removal	L/h	1.5	
Max. input consumption	W	2760	
Max. current	A	12	
Compressor	Model	DA130S1C-20FZ	
	Type	Twin-rotary DC inverter	
	Brand	Toshiba	
	Capacity	W	3860
	Input	W	990
	Rated current(RLA)	A	4.97
	Thermal protector	1NT01L-4639 or KSD301	
	Capacitor	uF	No
Refrigerant oil	ml	500	
Indoor fan motor	Model	RPG28D	
	Brand	Welling	
	Input	W	58
	Capacitor	uF	1.5
	Speed(hi/mi/lo)	r/min	1200/1000/880
Indoor air flow (Hi/Mi/Lo)		m3/h	720/600/530
Indoor noise level (Hi/Mi/Lo)		dB(A)	40/34/28
Indoor unit	Dimension (W*H*D)	mm	995*292*200
	Packing (W*H*D)	mm	1070*370*275
	Net/Gross weight	Kg	11.5/14
Outdoor fan motor	Model	YDK24-6G	
	Brand	Welling	
	Input	W	67/48
	Capacitor	uF	2.5
	Speed	r/min	800/550
Outdoor air flow		m3/h	2000
Outdoor noise level		dB(A)	56
Outdoor unit	Dimension(W*H*D)	mm	760*590*285
	Packing (W*H*D)	mm	887*645*355
	Net/Gross weight	g	39.5/42
Refrigerant type R410A		g	1180
Refrigerant piping	Liquid side/ Gas side	mm	Φ6.35/Φ12.7
	Max. refrigerant pipe length	m	25
	Max. difference in level	m	10
Operation temp		□	17 ~ 30
Ambient temp temperature		□	-15 ~ 50

The above design and specifications are subject to change without prior notice for product improvement.

## 5. Refrigerant cycle diagram

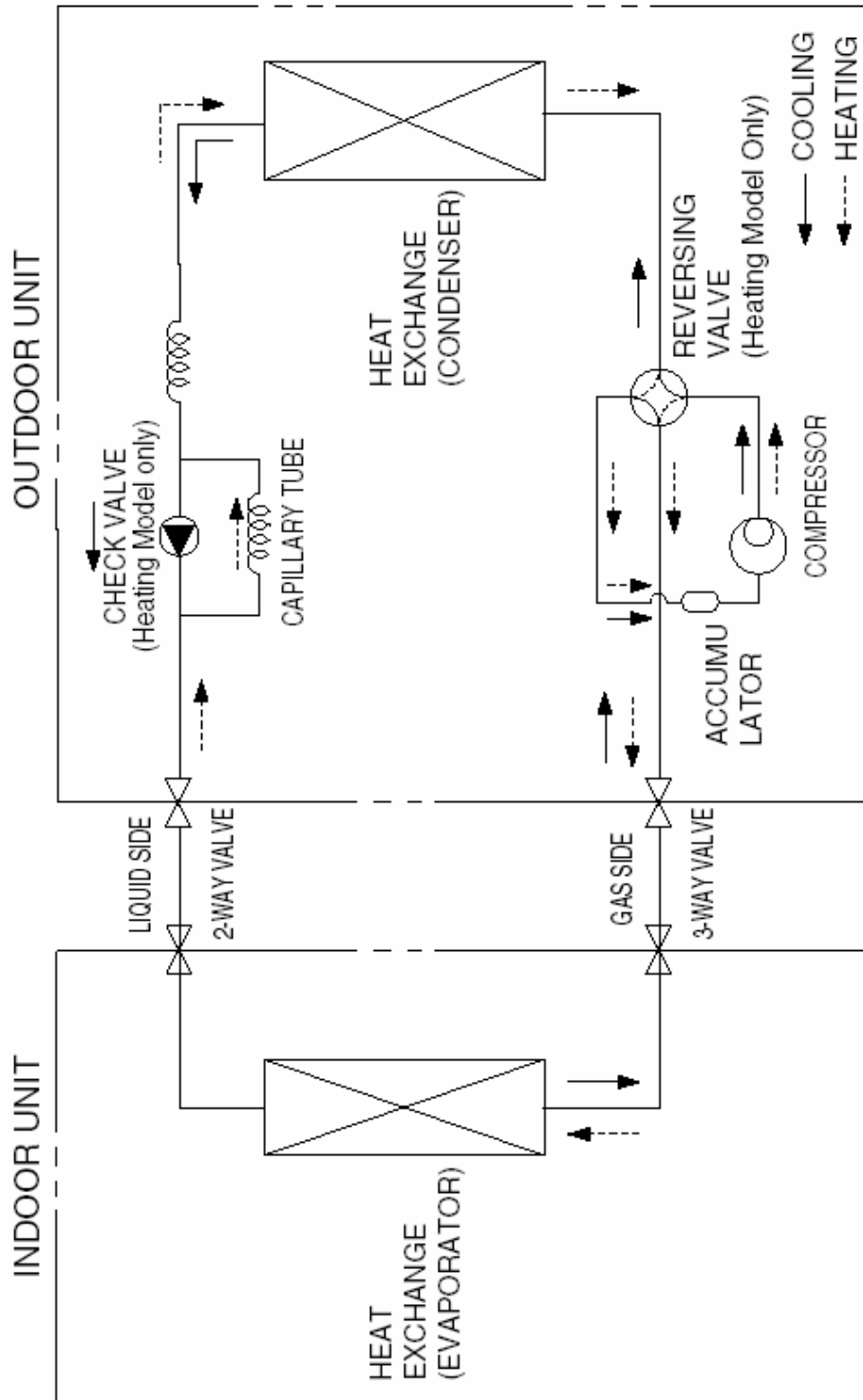

# 6. Wiring diagram

## 6.1 Indoor Unit

MS9Vi-18HRDN1-QC2

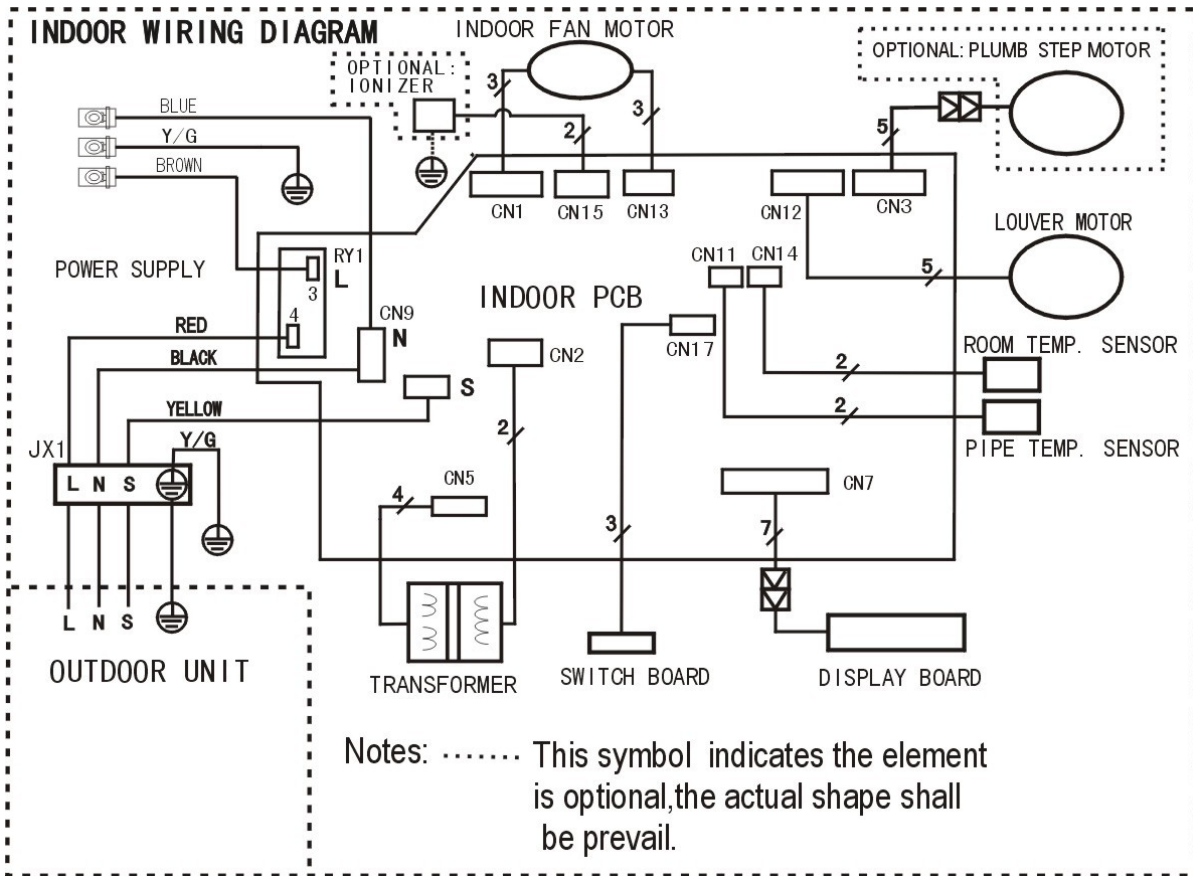

## 6.2 Outdoor Unit

MOCi-18HDN1-QC2

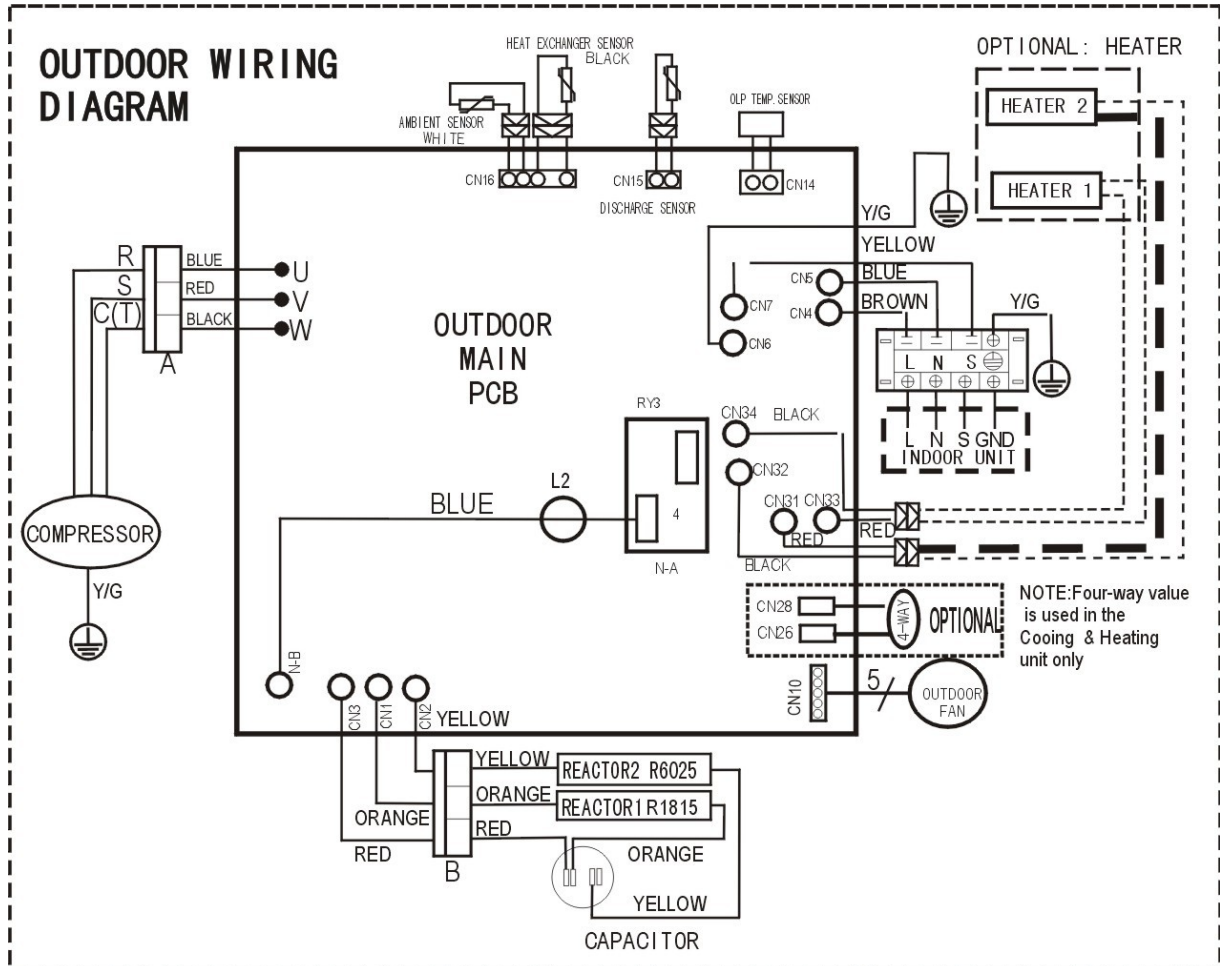

## 7. Installation details

### 7.1 Wrench torque sheet for installation

Outside diameter		Torque
mm	inch	Kgf.m
Φ6.35	1/4	1.8
Φ12.7	1/2	5.5

### 7.2 Connecting the cables

The power cord of connect should be selected according to the following specifications sheet.

Unit	Grade		
	9K	12K	18K
mm <sup>2</sup>	1.5	1.5	2.5

### 7.3 Pipe length and the elevation

Capacity Btu/h	Pipe size		Standard length (m)	Max. Elevation B (m)	Max. Length A (m)	Additional refrigeran t (g/m)
	Gas	Liquid				
18K	1/2" (Φ12.7)	1/4" (Φ6.35)	5	10	25	20

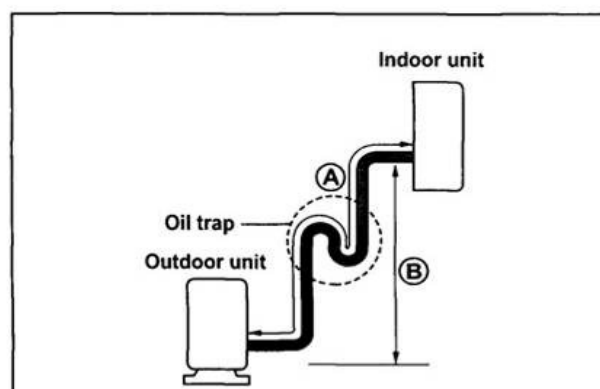
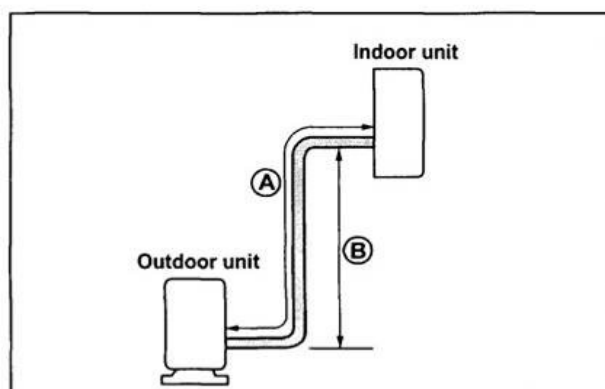

#### Caution:

Capacity is based on standard length and maximum allowance length is base of reliability.

Oil trap should be installed per 5-7 meters.

### 7.4 Air purging of the piping and indoor unit

#### Required tools:

Hexagonal wrench; adjustable wrench; torque wrenches, wrench to hold the joints and gas leak detector.

#### Note:

The air in the indoor unit and in the piping must be purged. If air remains in the refrigeration piping, it will affect the compressor, reduce the cooling capacity, and could lead to a malfunction of unit.

Be sure, using a torque wrench to tighten the service port cap (after using the service port), so that it prevents the gas leakage from the refrigeration cycle.

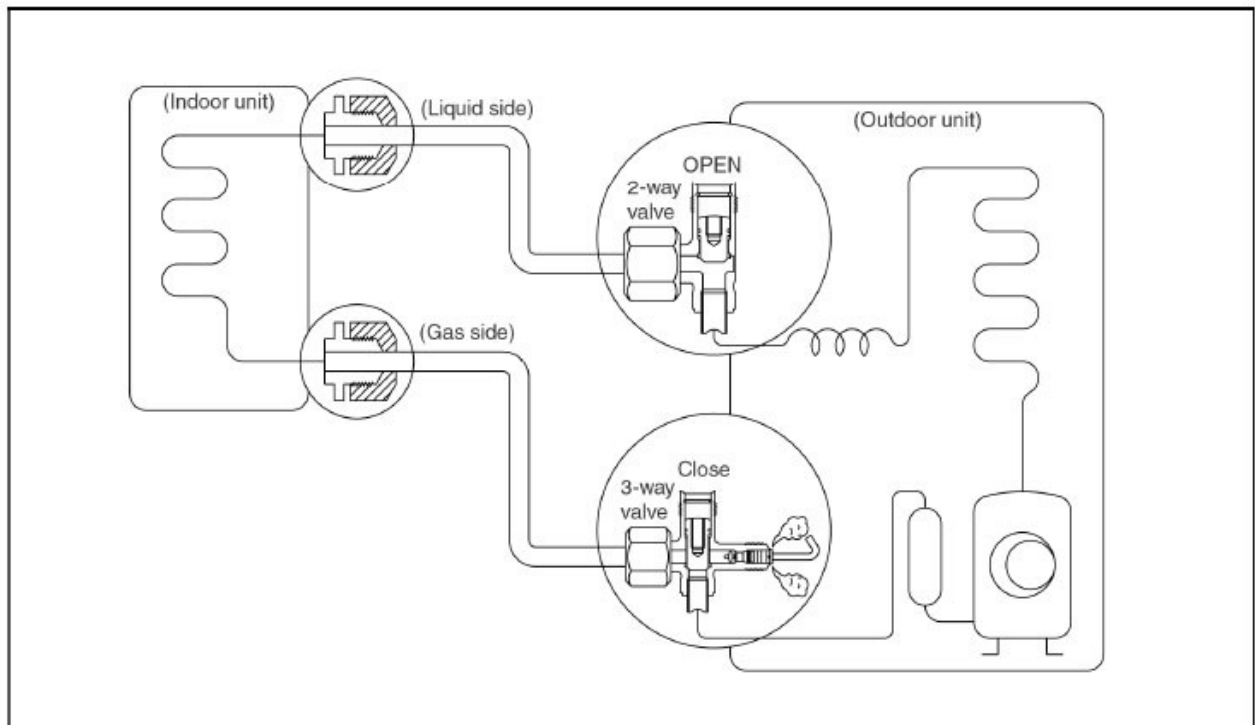

### Procedure

1. Recheck the piping connections.
2. Open the valve stem of the 2-way valve counterclockwise approximately 90°, wait 10 seconds, and then set it to closed position. Be sure to use a hexagonal wrench to operate the valve stem.
3. Check for gas leakage. Check the flare connection for gas leakage
4. Purge the air from the system. Set the 2-way valve to the open position and remove the cap from the 3-way valve's service port. Using the hexagonal wrench to press the valve core pin, discharge for three seconds and then wait for one minute.
5. Use torque wrench to tighten the service port cap to a torque of 1.8 kgf.m. (18N.m)
6. Set the 3-way valve to the opened position.
7. Mounted the valve stem nuts to the 2-way and 3-way valves.
8. Check for gas leakage. At this time, especially check for gas leakage from

the 2-way and 3-way stem nuts, and from the service port.

### Caution:

If gas leakage is discovered in step (3) above, take the following measures.

If the leaks stop when the piping connections are tightened further, continue working from step (4).

If the gas leaks do not stop when the connections are retightened, repair the location of the leak, discharge all of the gas through the service port, and then recharge with the specified amount of gas from a gas cylinder.



## 7.5 Pumping down (Re-installation)

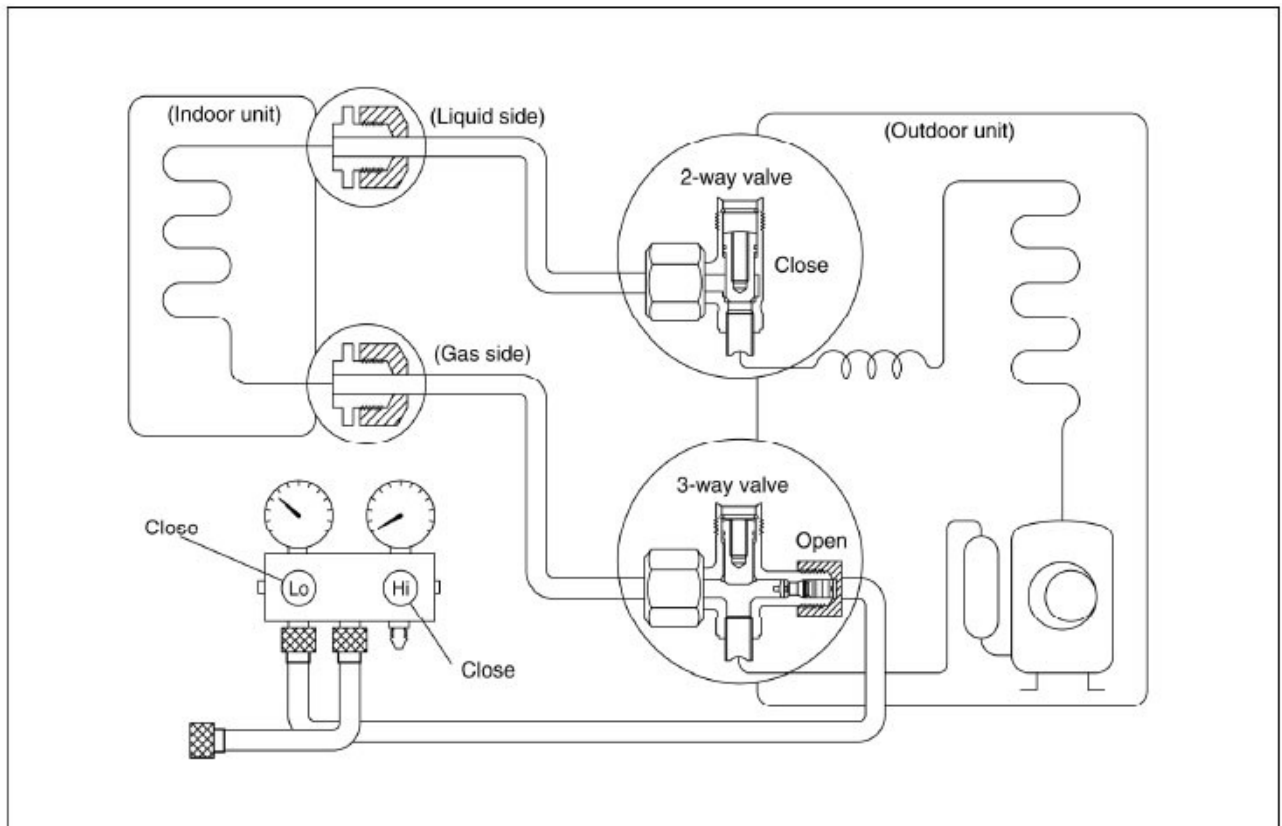

### Procedure

1. Confirm that both the 2-way and 3-way valves are set to the opened position.  
Remove the valve stem caps and confirm that the valve stems are in the opened position.  
Be sure to use a hexagonal wrench to operate the valve stems.
2. Operate the unit for 10 to 15 minutes.
3. Stop operation and wait for 3 minutes, then connect the charge set to the service port of the 3-way valve.  
Connect the charge hose with the push pin to the gas service port.
5. Air purging of the charge hose.  
Open the low-pressure valve on the charge set slightly to purge air from the charge hose.
6. Set the 2-way valve to the close position.
7. Operate the air conditioner at the cooling cycle and stop it when the gauge indicates 0.1MPa.
8. Immediately set the 3-way valve to the closed position.  
Do this quickly so that the gauge ends up indicating 0.3 to 0.5Mpa.  
Disconnect the charge set, and amount the 2-way and 3-way valve's stem nuts and service port caps.  
Use a torque wrench to tighten the service port cap to a torque of 1.8 kgf.m.  
Be sure to check for gas leakage.

## 7.6 Re-air purging (Re-installation)

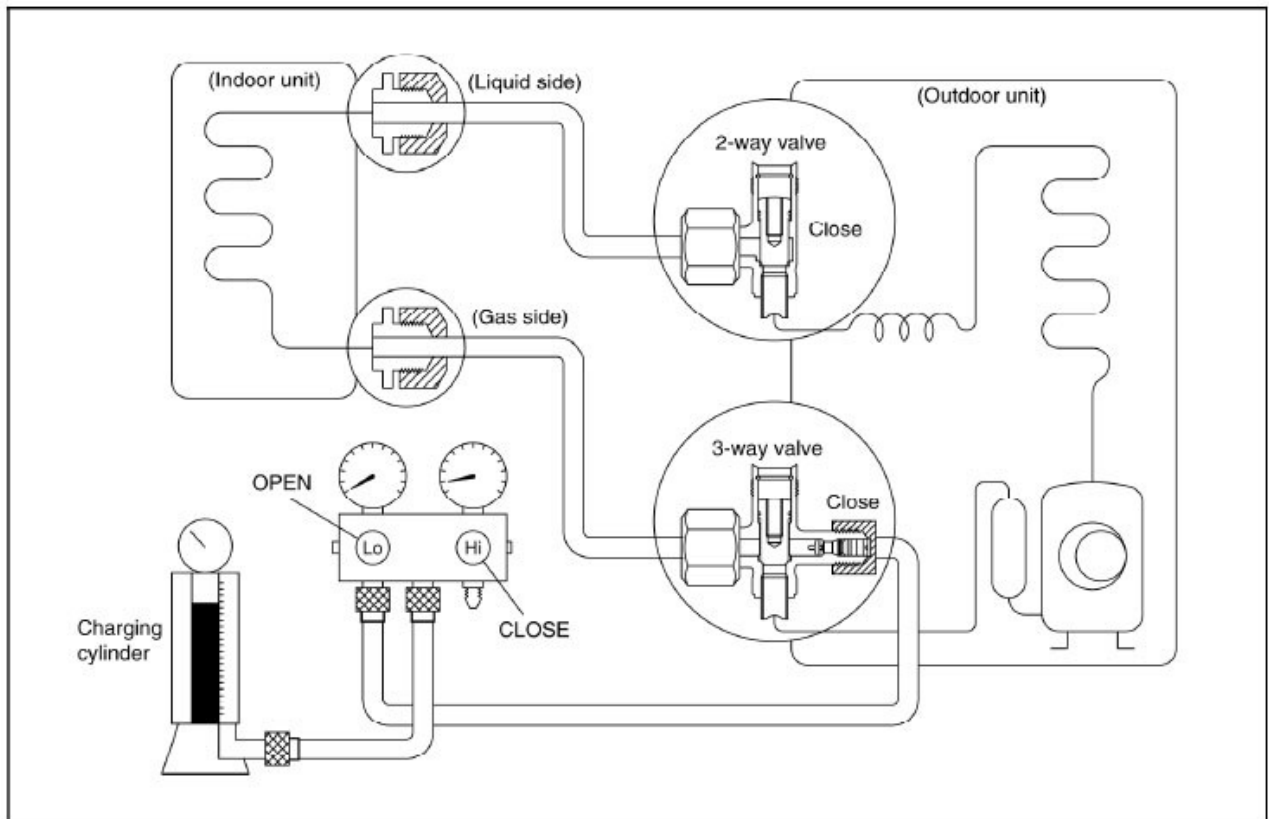

### Procedure:

1. Confirm that both the 2-way and 3-way valves are set to the closed position.
2. Connect the charge set and a charging cylinder to the service port of the 3-way valve.  
Leave the valve on the charging cylinder closed.
3. Air purging.  
Open the valves on the charging cylinder and the charge set. Purge the air by loosening the flare nut on the 2-way valve approximately 45° for 3 seconds then closing it for 1 minute; repeat 3 times.  
After purging the air, use a torque wrench to tighten the flare nut to on the 2-way valve.
4. Check the gas leakage.  
Check the flare connections for gas leakage.
5. Discharge the refrigerant.  
Close the valve on the charging cylinder and discharge the refrigerant until the gauge indicates 0.3 to 0.5 Mpa.
6. Disconnect the charge set and the charging cylinder, and set the 2-way and 3-way valves to the open position.  
Be sure to use a hexagonal wrench to operate the valve stems.
7. Mount the valve stems nuts and the service port cap.  
Be sure to use a torque wrench to tighten the service port cap to a torque 18N.m.  
Be sure to check the gas leakage.

## 7.7 Balance refrigerant of the 2-way, 3-way valves

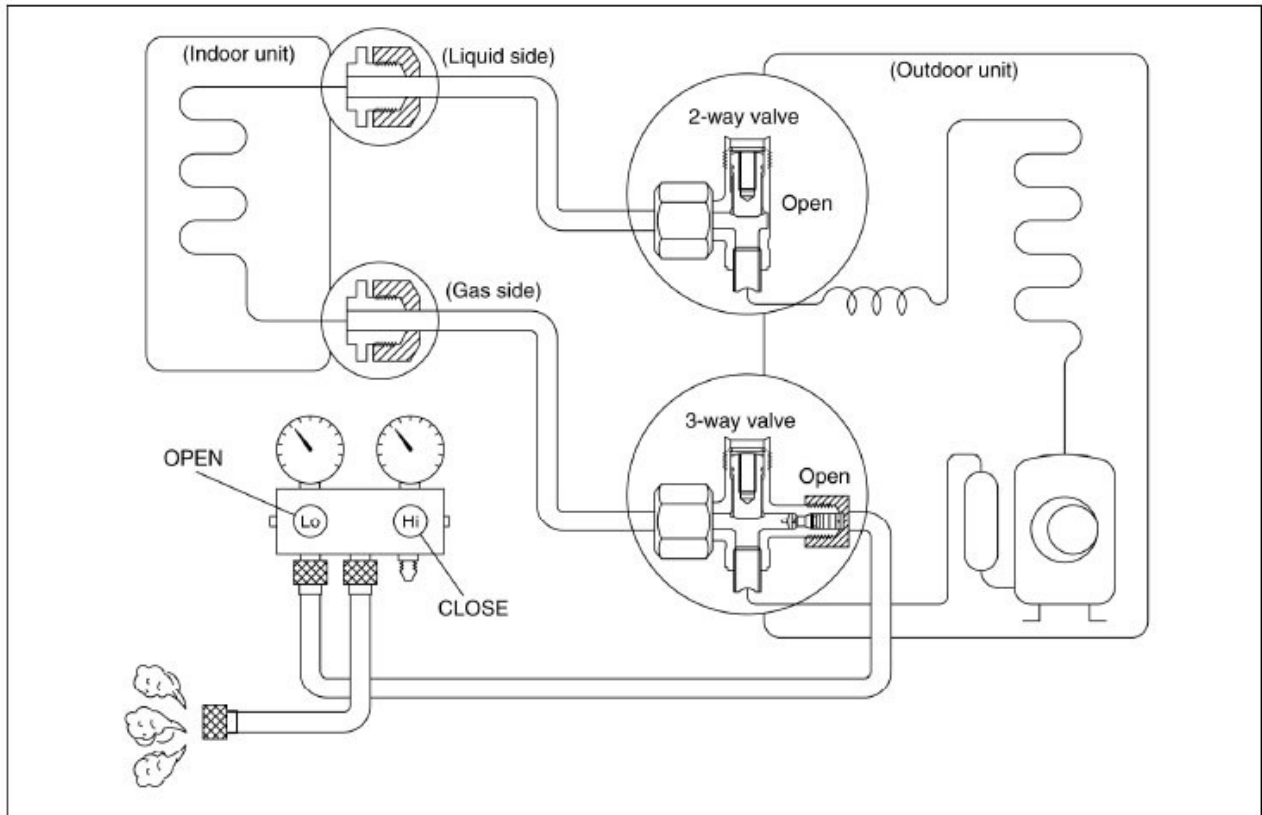

### Procedure:

1. Confirm that both the 2-way and 3-way valves are set to the open position.
2. Connect the charge set to the 3-way valve's service port.  
Leave the valve on the charge set closed.  
Connect the charge hose with the push pin to the service port.
3. Open the valves (Low side) on the charge set and discharge the refrigerant until the gauge indicates 0.05 to 0.1Mpa.  
If there is no air in the refrigeration cycle [the pressure when the air conditioner is not running is higher than 0.1Mpa, discharge the refrigerant until the gauge indicates 0.05 to 0.1 Mpa. If this is the case, it will not be necessary to apply a evacuation.  
Discharge the refrigeration gradually; if it is discharged too suddenly, the refrigeration oil will be discharged.

## 7.8 Evacuation

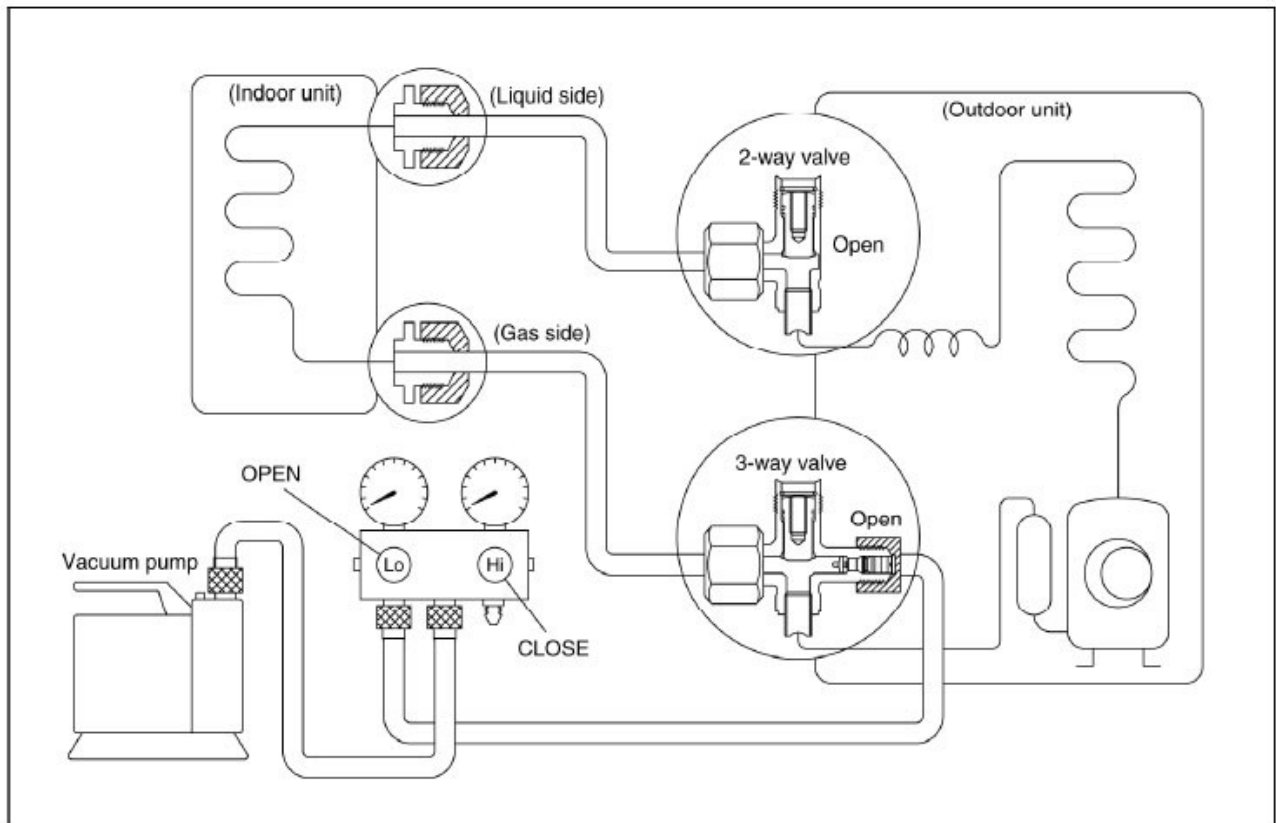

### Procedure:

1. Connect the vacuum pump to the charge set's centre hose.
2. Evacuation for approximately one hour.  
Confirm that the gauge needle has moved toward -0.1 Mpa (-76 cmHg) [vacuum of 4 mmHg or less].
3. Close the valve (Low side) on the charge set, turn off the vacuum pump, and confirm that the gauge needle does not move (approximately 5 minutes after turning off the vacuum pump).
4. Disconnect the charge hose from the vacuum pump.  
Vacuum pump oil, if the vacuum pump oil becomes dirty or depleted, replenish as needed.

## 7.9 Gas charging

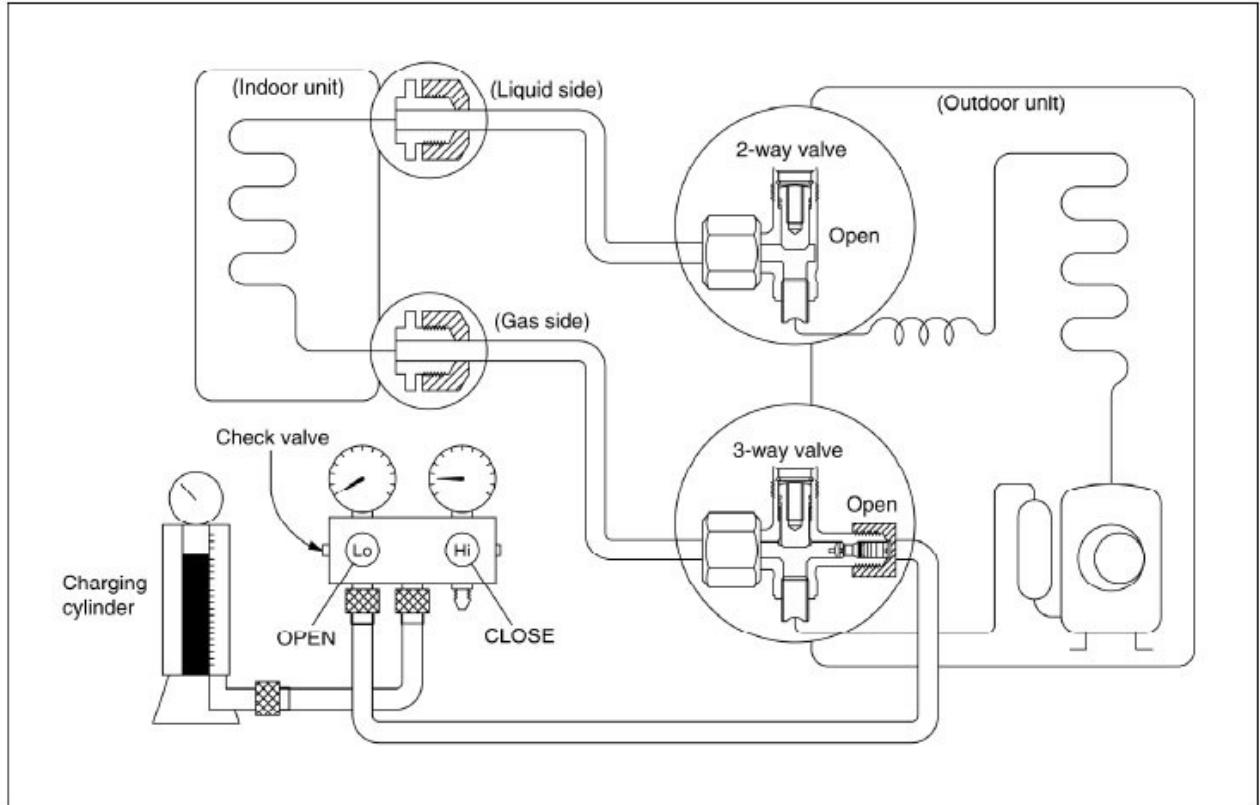

### Procedure:

1. Connect the charge hose to the charging cylinder.

Connect the charge hose which you disconnected from the vacuum pump to the valve at the bottom of the cylinder.

2. Purge the air from the charge hose.

Open the valve at the bottom of the cylinder and press the check valve on the charge set to purge the air (be careful of the liquid refrigerant).

3. Open the valves (Low side) on the charge set and charge the system with liquid refrigerant.

If the system cannot be charge with the specified amount of refrigerant, it can be charged with a little at a time (approximately 150g each time) while operating the air conditioner in the cooling cycle; however, one time is not sufficient, wait approximately 1 minute and then repeat the procedure.(pumping down-pin).

4. Immediately disconnect the charge hose from the 3-way valve's service port.

Stopping partway will allow the refrigerant to be discharged.

If the system has been charged with liquid refrigerant while operating the air conditioner, turn off the air conditioner before disconnecting the hose.

5. Mounted the valve stem caps and the service port

Use torque wrench to tighten the service port cap to a torque of 18N.m.

Be sure to check for gas leakage.

# 8. Operation characteristics

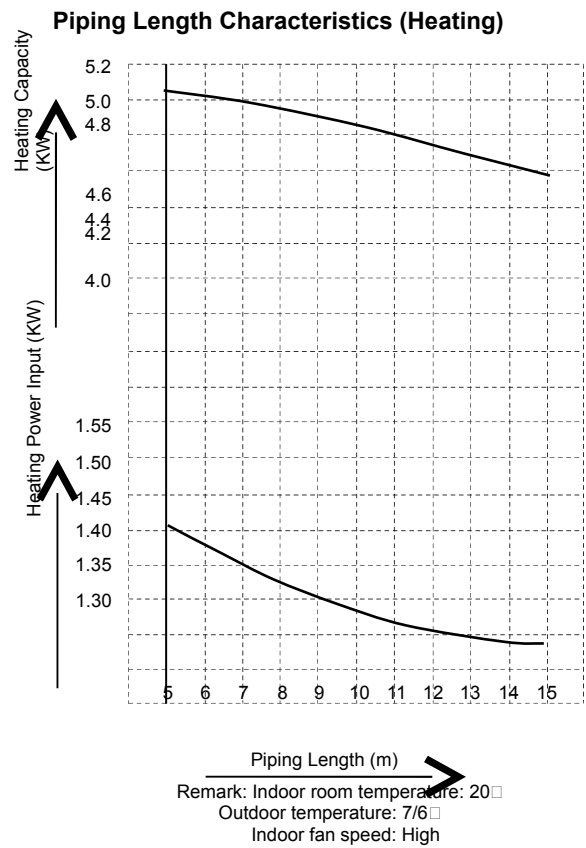
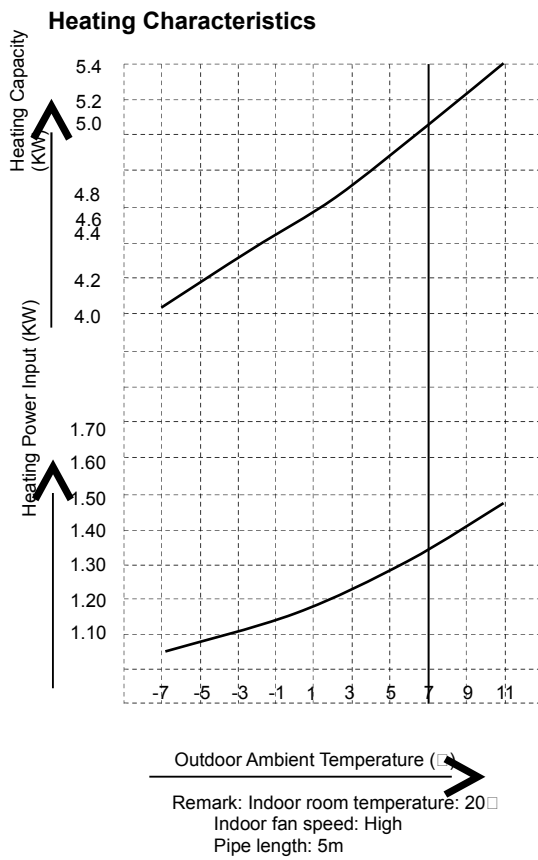
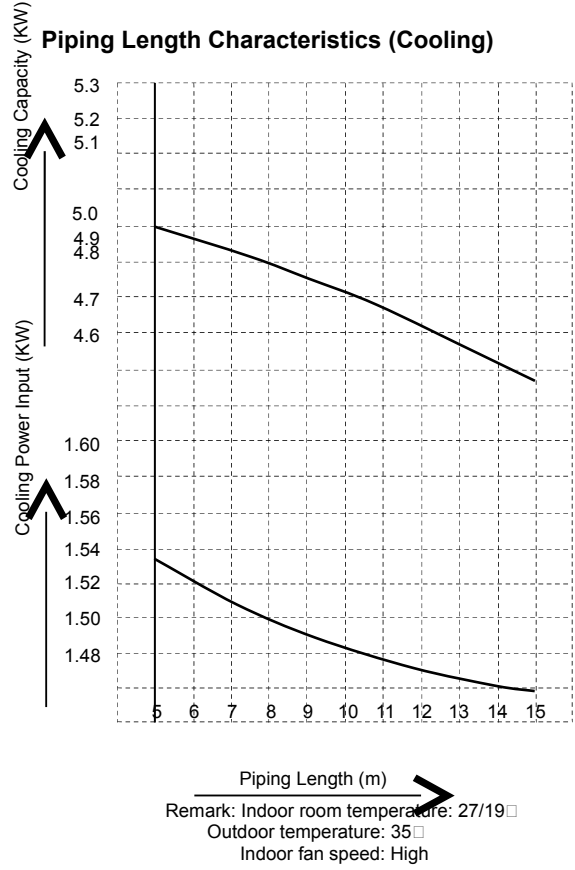
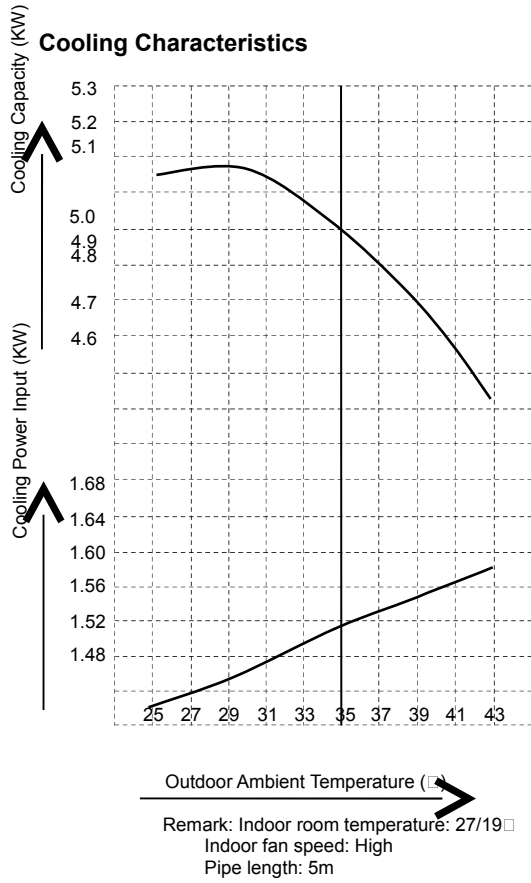

## 9. Electronic function

### 9.1 Abbreviation

- T1: Indoor ambient temperature
- T2: Pipe temperature of indoor heat exchanger
- T3: Pipe temperature of outdoor heat exchanger
- T4: Outdoor ambient temperature

### 9.2 Display function

#### 9.2.1 Icon explanation on indoor display board.

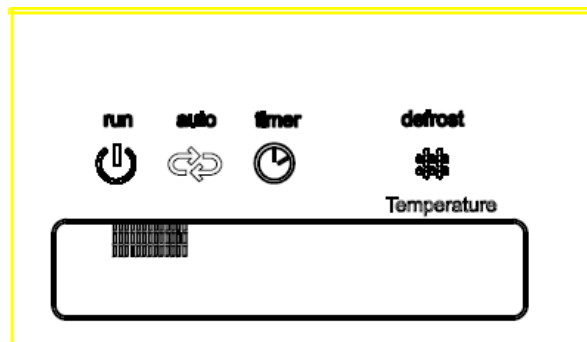

#### 1 Run indicator

Flash at 0.5Hz when the unit is standby. Illuminate when the unit is turned on.

#### ② Auto indicator

This indicator illuminates when the air conditioner is in AUTO operation.

#### ③ Timer indicator

This indicator illuminates when TIMER is set ON/OFF.

#### ④ Defrost Indicator

This indicator illuminates when the air conditioner starts defrosting automatically or when the warm air control feature is activated in heating mode.

#### ⑤ TEMPERATURE indicator

Usually it displays the temperature settings. When change the setting temperature, this indicator begins to flash, and stops 20 seconds later. It displays the room temperature when the air conditioner is in FAN only operation, and the range of that is 0~50℃. It will also display the error codes when malfunction or protection happen.

#### ⑥ Frequency indicator

This indicator appears only when the compressor is in operation and indicates the current operating frequency.

#### 9.2.2 LED display control function.

Pressing "LED display" button on remote controller will turn off all displays on indoor unit, while pressing once again, all displays will resume.

### 9.3 Protection

#### 9.3.1 Protection of compressor top temperature.

When the Over-load Protector is cut due to too high temperature of compressor top, the unit will stop. When the Over-load Protector is closed again due to decreasing of compressor top temperature, the unit will restart( in this case the compressor is restricted by Three Minutes Delay protection).

#### 9.3.2 Protection of discharge temperature (Td).

- 1) Compressor will stop immediately if  $T_d > 115^\circ\text{C}$  for 5s.
- 2) If  $90^\circ\text{C} \leq T_d \leq 115^\circ\text{C}$ , compressor will run with restricted frequency.
- 3) If  $T_d < 90^\circ\text{C}$ , compressor will restart or run without restricted frequency

#### 9.3.3 Three Minutes Delay at restart for compressor.

It will take 3 minutes every time when compressor starts.

It will take only 1 minute when the unit is powered on at first time.

#### 9.3.4 Temperature sensor protection at open circuit or short circuit.

#### 9.3.5 Protection of indoor fan speed.

When indoor fan speed is too low (lower than 300rpm for 50 seconds), the unit will stop and LED display error code and can't return to normal operation automatically.

#### 9.3.6 Cross Zero signal error warning.

If there are no Cross Zero signal or the alternation of Cross Zero signal is not correct, the unit will stop and LED display error code .

#### 9.3.7 Inverter module Protection.

Inverter module has a protection function against current, voltage and temperature. If these protections happened, the unit will stop and LED display error code .

#### 9.3.8 Indoor fan delayed open function.

When the unit is turned on at all modes, the indoor fan will operate 10 seconds later than the action of louver.

#### 9.3.9 Compressor preheating function.

- 1) Preheating permitting condition:

If  $T_4$ (outdoor ambient temperature)  $\leq 3^\circ\text{C}$  and the machine connects to power supply newly or if  $T_4 \leq 3^\circ\text{C}$  and compressor has stopped for over 3 hours, the compressor heating cable will work.

- 2) Preheating mode:

A weak current flows through the coil of compressor from the wiring terminal of compressor, then the compressor is heated without operation.

- 3) Preheating release condition:

If  $T_4 \geq 5^\circ\text{C}$  or user turns on the machine and compressor runs, preheating function will stop.

#### 9.3.10 Compressor heating cable

If outdoor temperature is lower than  $5^\circ\text{C}$ , the compressor heating cable begins to work. If outdoor temperature is higher than  $15^\circ\text{C}$ , the compressor heating cable stops working.

## 9.4 Fan-Only Mode

9.4.1 Temperature setting function is disabled, and no setting temperature display.

9.4.2 In this mode, the action of louver is the same as in cooling mode.

9.4.3 The action of auto fan in fan-only mode is the same as auto fan in cooling mode with  $24^\circ\text{C}$  setting temperature.

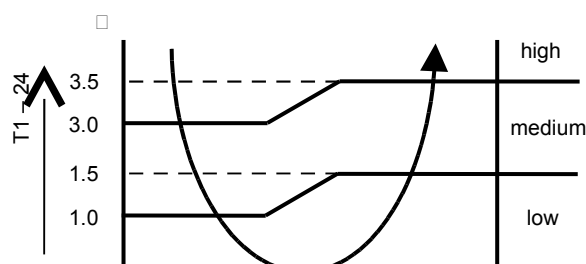



## 9.5 Cooling Mode

9.5.1 After starting, the operation frequency of compressor submits to following rule.

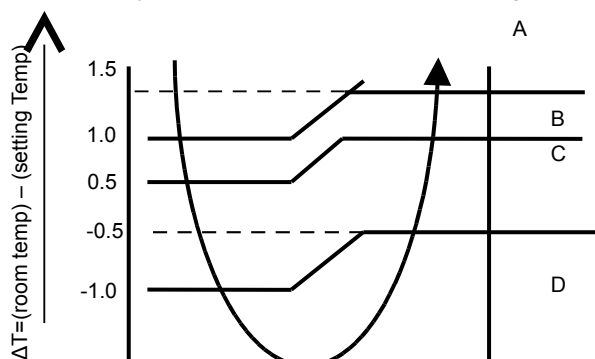

When the machine is running and  $\Delta T$ (=room temp. – setting temp.) changes, the frequency of compressor will rise or descend a grade (7 minutes after starting).

After starting, if  $\Delta T$  stays in a zone for 3 minutes, the frequency will change as follow:

Zone A : Current frequency rise a grade till the maximum grade F8.

Zone B: Keep the current frequency of compressor.

Zone C: Descend the current frequency of compressor until F1.

Zone D: Compressor stops after running as the minimum frequency F1 for 60 minutes or  $\Delta T$  is less than  $-2$ .

9.5.2 Indoor heat exchanger anti-freezing function.

If  $T_2$  is lower than  $0^\circ$ , the compressor stops and resumes when  $T_2 > 5^\circ$ .

9.5.3 Outdoor unit current control in cooling mode(refer to the parameter table)

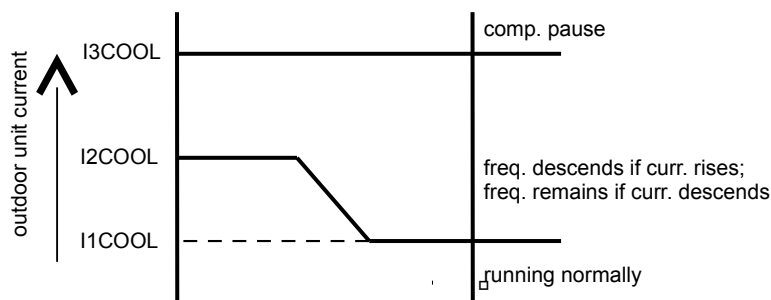

9.5.4 Rating capacity test function

1) Set the indoor unit with remote controller as: high fan, 17 in cooling mode, then press "TURBO" button on controller 6 times or more within 10 seconds(make sure indoor unit receives these signals), the machine will turn into rating capacity test mode, the buzzer will make a "di" sound for 2 seconds continuously. Also, indoor fan will change to rating speed, the frequency of compressor will be fixed as rating value. Any condition of above is not satisfied, the machine cannot be turned into rating capacity test mode.

2) The machine will quit from the rating capacity test mode if running for 5 hours or changing fan speed or setting temperature.

9.5.5 Turbo function(press the "TURBO" button on remote controller)

1) Elevate current frequency to a higher grade.

- 2) Indoor fan turns to turbo speed.
- 3) After running for 30 minutes the machine will turn back to previous setting mode.

9.5.6 Indoor fan operation rule.

- 1) In cooling mode, indoor fan runs all the time and the speed can be selected as high, medium, low and auto.
- 2) Auto fan in cooling mode acts as follow:

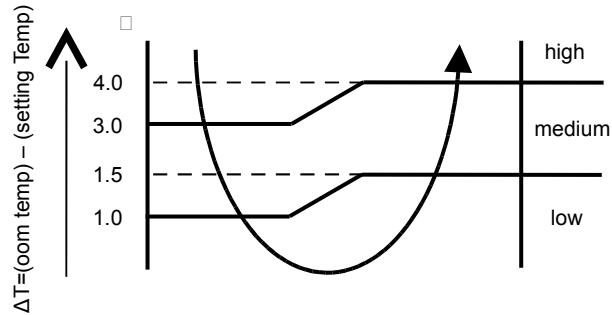

3 □ 52□

9.5.7 Condenser high temperature protection function(in cooling and drying mode)

If T3 □ 60□ for 5 seconds, compressor will stop immediately, and the machine will not resume until T

### 9.6 Drying mode

9.6.1 Indoor fan speed is fixed at breeze grade and can't be changed. The horizontal angle is the same as in cooling mode.

9.6.2 Room overlow temperature protection

In drying mode, if room temperature is lower than 10□, compressor will stop and not resume until room temperature climbs up to 12□

9.6.3 Evaporator anti-freezing protection, condenser high temperature protection and outdoor unit frequency limit are valid, and they are the same as that in cooling mode.

9.6.4 Horizontal louver action is the same as that in cooling mode.

### 9.7 Heating mode

9.7.1 Indoor fan action:

- 1) Anti-cold-wind function.

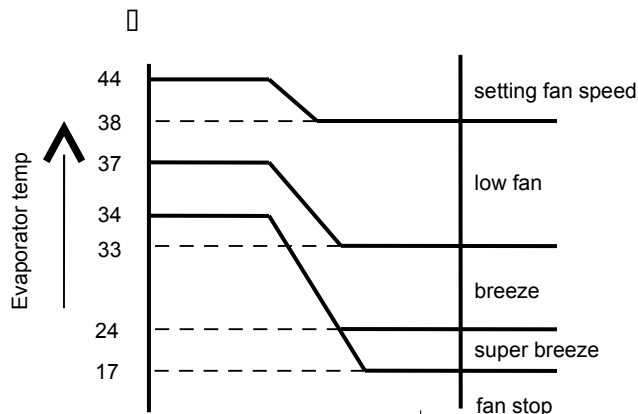

2) If the compressor stops caused by room temperature rising, indoor fan will be forced to run 127 seconds with breeze. During this period, anti-cold-wind is disabled. After this, anti-cold -wind function is available.

3) If the machine runs in rating capacity test mode, indoor fan runs with rating speed, and anti-cold-wind is disabled.

9.7.2 Indoor fan speed can be set as high, medium, low or auto grade, but anti-cold-wind function is preferential.  
Auto fan action in heating mode.

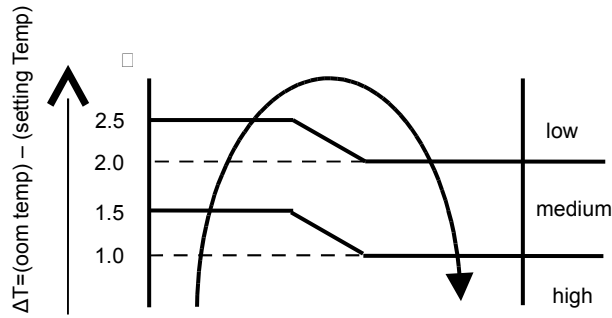

9.7.3 After start the operation frequency of compressor submits to following rule:

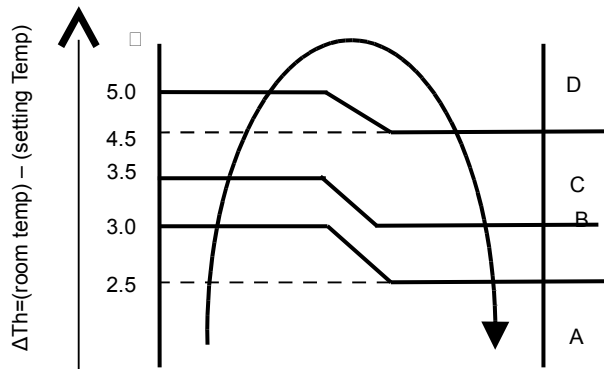

When the machine runs, if  $\Delta Th$  stays in a zone for 3 minutes, action of frequency is as follow:

- Zone A: Elevate the current frequency one grade, and not stop until the maximum grade.
- Zone B: Keep the current frequency.
- Zone C: Descend the current frequency one grade.
- Zone D: Compressor stops after running with F1 for 60 minutes or when  $\Delta Th \geq 6$

9.7.4 Outdoor unit current control in heating mode.

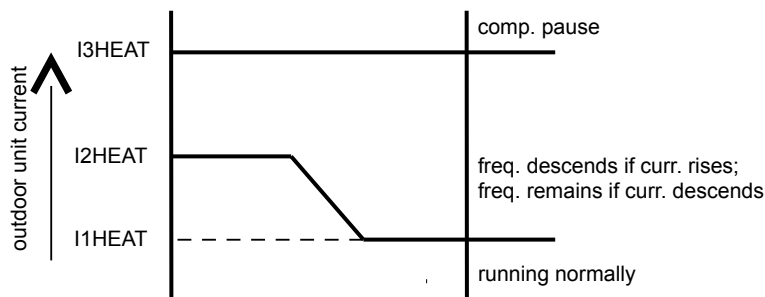

9.7.5 Indoor heat exchanger high temperature protection.

If  $T2 \geq 60^\circ$  the compressor will stop and not resume until  $T2 \leq 48^\circ$

9.7.6

Defrosting mode.

1) Condition of defrosting.

**Condition 1:** If  $T4 \leq 0^\circ$

When the units are running, if the following two items are satisfied the units start defrosting:

- a) The units runs with  $T3 \leq 3^\circ$  for 40 minutes and  $T3$  keeps lower than  $-6^\circ$  for more than 3 minutes.
- b) The units runs with  $T3 \leq 3^\circ$  for 80 minutes and  $T3$  keeps lower than  $-4^\circ$  for more than 3 minutes.

**Condition 2:** If  $T4 \leq 0^\circ$

The program judges according to the condition 1, if the two items are satisfied, then judges if  $T2$  has descended for more than  $5^\circ$  if it has the machine starts defrosting, or continues to judge  $T2$  and will not defrost until  $T2$  drops more than  $5^\circ$

**Condition 3:** No matter what value  $T4$  is, if the machine runs with  $T3 \leq 3^\circ$  for more than 120 minutes and  $T3$  keeps lower than  $-2^\circ$  for more than 3 minutes, the machine will defrost, no matter if  $T2$  drops for more than  $5^\circ$  or not.

2) Condition of ending defrosting.

If any one of following items is satisfied, defrosting will finish and the machine will turn to normal heating mode.

- a)  $T3$  rises to be higher than  $12^\circ$
- b)  $T3$  rises to be higher than  $8^\circ$  and remains for 80 seconds.
- c) The machine has run for 10 minutes in defrosting.

9.7.7

Defrosting action.

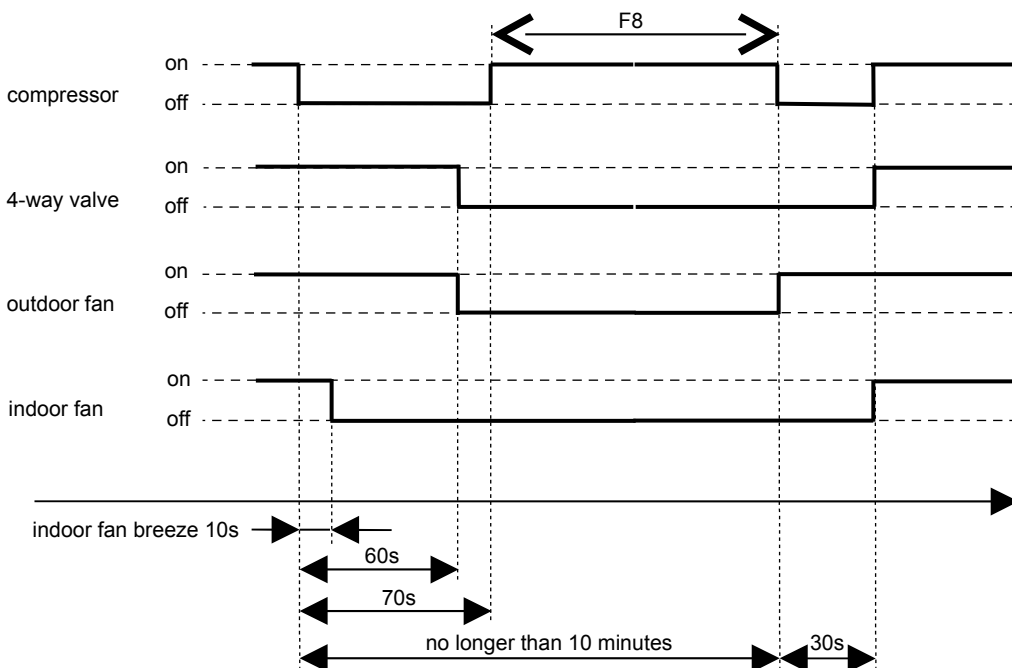

9.7.8 Rating capacity test function.

1) Set the indoor unit with remote controller as: high fan,  $30^\circ$  in heating mode, then press "TURBO" button on controller 6 times or more within 10 seconds (make sure indoor unit receives these signals), the machine will turn into rating capacity test mode, the buzzer will make a "di" sound for 2 seconds continuously. Also, indoor fan will change to rating speed, the frequency of compressor will be fixed as rating value. Any condition of above is not satisfied, the machine cannot be turned into rating capacity test mode.

2) The machine will quit from the rating capacity test mode if running for 5 hours or changing fan speed or setting temperature.

9.7.9 Turbo function in heating mode. (press the “TURBO” button on remote controller)

- 1) Elevate current frequency(excluding F8) to a higher grade. If indoor fan is in low speed or pause caused by defrosting or anti-cold-wind function, frequency of compressor will not be elevated one grade until these limit has been released.
- 2) Indoor fan changes to turbo speed and anti-cold-wind function is valid.

## 9.8 Auto mode function

9.8.1 This mode can be chosen with remote controller and the setting temperature can be changed between 17~30°C

In auto mode, the machine will choose cooling, heating or fan-only mode according to  $\Delta T(\Delta T = T1 - Ts)$ .

$\Delta T = T1 - Ts$	Running mode
$\Delta T \geq 4$	Cooling
$-1 \leq \Delta T \leq 1$	Fan-only
$\Delta T \leq -1$	Heating

9.8.2 Indoor fan will choose auto speed of relevant mode.

9.8.3 If the machine switches mode between heating and cooling, compressor will keep stopping for 15 minutes and then rechoose mode according to  $\Delta T$ .

9.8.4 If the setting temperature is modified, the machine will rechoose running function.

## 9.9 Forced operation function

9.9.1 Forced cooling and auto function can carry out with a touch button. In these two modes, the machine can be changed by remote controller to any other mode at any moment.

9.9.2 When the machine is off, pressing the touch button once, the unit will enter forced auto mode. When the machine is off, pressing the touch button twice within 5s, the unit will enter forced cooling mode. When the unit is running at forced auto or forced cooling mode, pressing the touch button continuously, the unit will be turned off.

9.9.3 In forced operation mode, all general protections is available.

9.9.4 In forced cooling mode, the unit will run with fixed frequency F2 at low speed. 30 minutes later, the unit will turn to normal auto mode with setting temperature 24°C

9.9.5 In forced auto mode, the unit will run with setting temperature 24°C

## 9.10 Action of 4-way valve

In cooling, drying, fan-only, or turning off mode, 4-way valve is off, while in heating mode 4-way valve is on. If the machine changes operation mode, 4-way valve will be delayed off 2 minutes after compressor stop. For defrosting, please refer to the passage “defrosting mode”.

## 9.11 Two speeds outdoor fan function

9.11.1 Outdoor fan starts at the same time with compressor, but stops 30 seconds later after compressor stop.

9.11.2 Outdoor fan action in heating mode(including heating in auto mode).

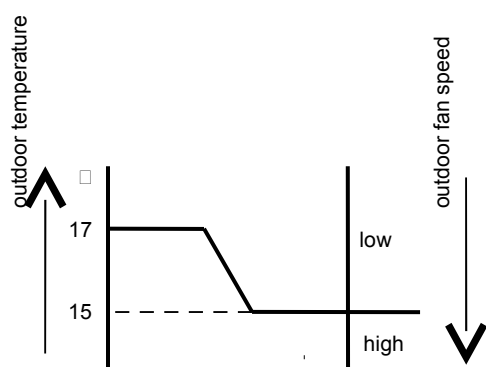

Outdoor fan action in heating mode (including heating in auto mode).

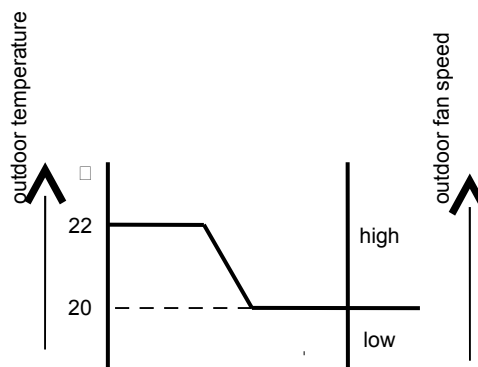

Outdoor fan action in cooling & drying mode (including cooling in auto & forced mode).

9.11.3 Outdoor fan action in cooling & drying mode(including cooling in auto & forced mode).

Please refer to the pic. above.

## 9.12 Timer function

9.12.1 Timing range is 24 hours, and the minimum resolution is 15 minutes.

9.12.2 Timer on. After turning off, the machine will turn on automatically when reaching the setting time.

9.12.3 Timer off. After turning on, the machine will turn off automatically when reaching the setting time.

9.12.4 Timer on/off. After turning off, the machine will turn on automatically when reaching the setting "on" time, and then turn off automatically when reaching the setting "off" time.

9.12.5 Timer off/on. After turning on, the machine will turn off automatically when reaching the setting "off" time, and then turn on automatically when reaching the setting "on" time.

9.12.6 The tolerance of Timer is 1 minute per hour.

## 9.13 Sleep function mode

9.13.1 Operation time in sleep mode is 7 hours. After 7 hours the machine quits this mode and turns off.

9.13.2 In cooling, heating or auto mode sleep function is available.

9.13.3 Operation process in sleep mode is as follow:

- 1) After pressing ECONOMIC or SLEEP button on controller, the machine will turn into sleep mode.
- 2) When cooling, the setting temperature rises 1℃(be lower than 30℃) every one hour, 2 hour later the rising stops and indoor fan is fixed as low speed.
- 3) When heating, the setting temperature descends 1℃(be lower than 30℃) every one hour, 2 hour later the descending stops and indoor fan is fixed as low speed, and anti-cold-wind is available.

9.13.4 If user uses timer on function in sleep mode, sleep function will pause and not resume until reaches the setting on time.

9.13.5 When user uses timer off function in sleep mode(or sleep function in timer off mode), if the timing time is less than 7 hours, sleep function will be cancelled when reaching the setting time. If the timing time is more than 7 hours, the machine will not stop until reaches the setting off time in sleep mode.

## 9.14 Auto-Restart function

The indoor unit is equipped with auto-restart function. In case of a sudden power failure, the setting conditions before the power failure will be restored. The unit will resume the previous operation setting automatically after 3 minutes when power returns.

## 9.15 Ionizer function(optional)

The indoor unit is equipped with ionizer, which is controlled by the CLEAN AIR button on the remote controller when the unit is turned on. Press the CLEAN AIR button to activate the function. Press it again to stop the function. During the time when ionizer being controlled by remote controller, ionizer will be turned off automatically, if indoor fan stops running due to malfunctions or anti-cold-wind. When indoor fan restarts after malfunctions being eliminated and anti-cold-wind being released, ionizer will be available again.

## 9.16 Outdoor chassis heating cable (optional)

Heating cable is fixed on outdoor chassis to help deicing and to avoid freezing. The heating cable's power is 85W, rated voltage is 220V-240V, and is controlled by program. If outdoor temperature is lower than 5℃, the heating cable will begin to work. If outdoor temperature is higher than 15℃, the heating cable will stop working.

# 10. Troubleshooting

### Safety

Because of there are capacitors in PCB and relative circuit in outdoor unit, even shut down the power supply, electricity power still are kept in capacitors, do not forget to discharge the electricity power in capacitor.

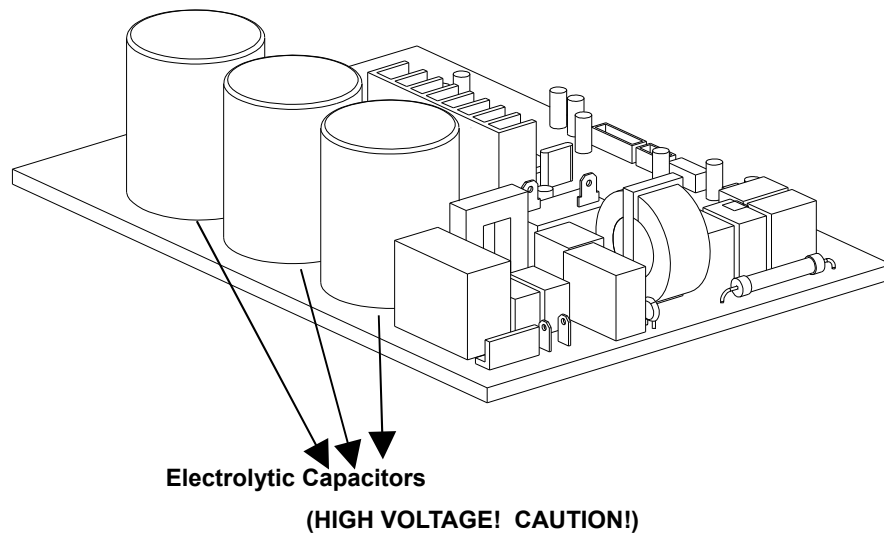

### Bulb (25-40W)

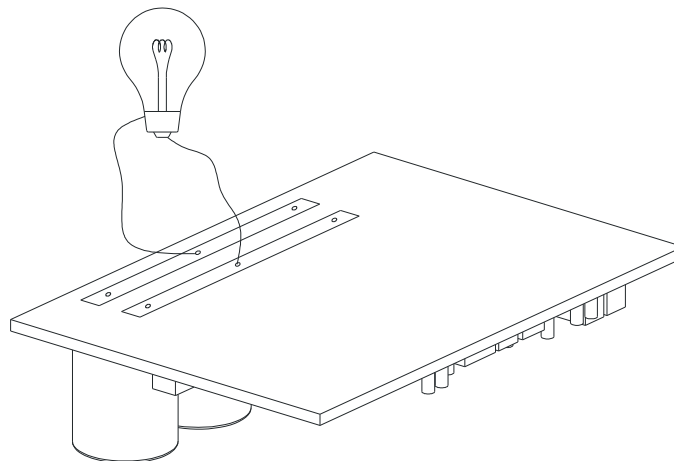

## 10.1 Indoor Unit Error Display

Display	LED STATUS
E0	EEPROM parameter error
E1	Indoor / outdoor units communication protection
E2	Zero-crossing signal error
E3	Indoor fan speed out of control
E5	Open or short circuit of outdoor temperature sensor
E6	Open or short circuit of room or evaporator temperature sensor
P0	Inverter module over-strong current protection
P1	Over voltage or too low voltage protection
P2	Temperature protection of compressor top.
P4	Inverter compressor drive error



## 10.2 Diagnosis and Solution

### 10.2.1 E0(EEPROM parameter error) error diagnosis and solution

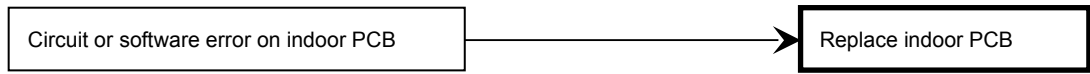

### 10.2.2 E1(indoor / outdoor units communication protection) error diagnosis and solution

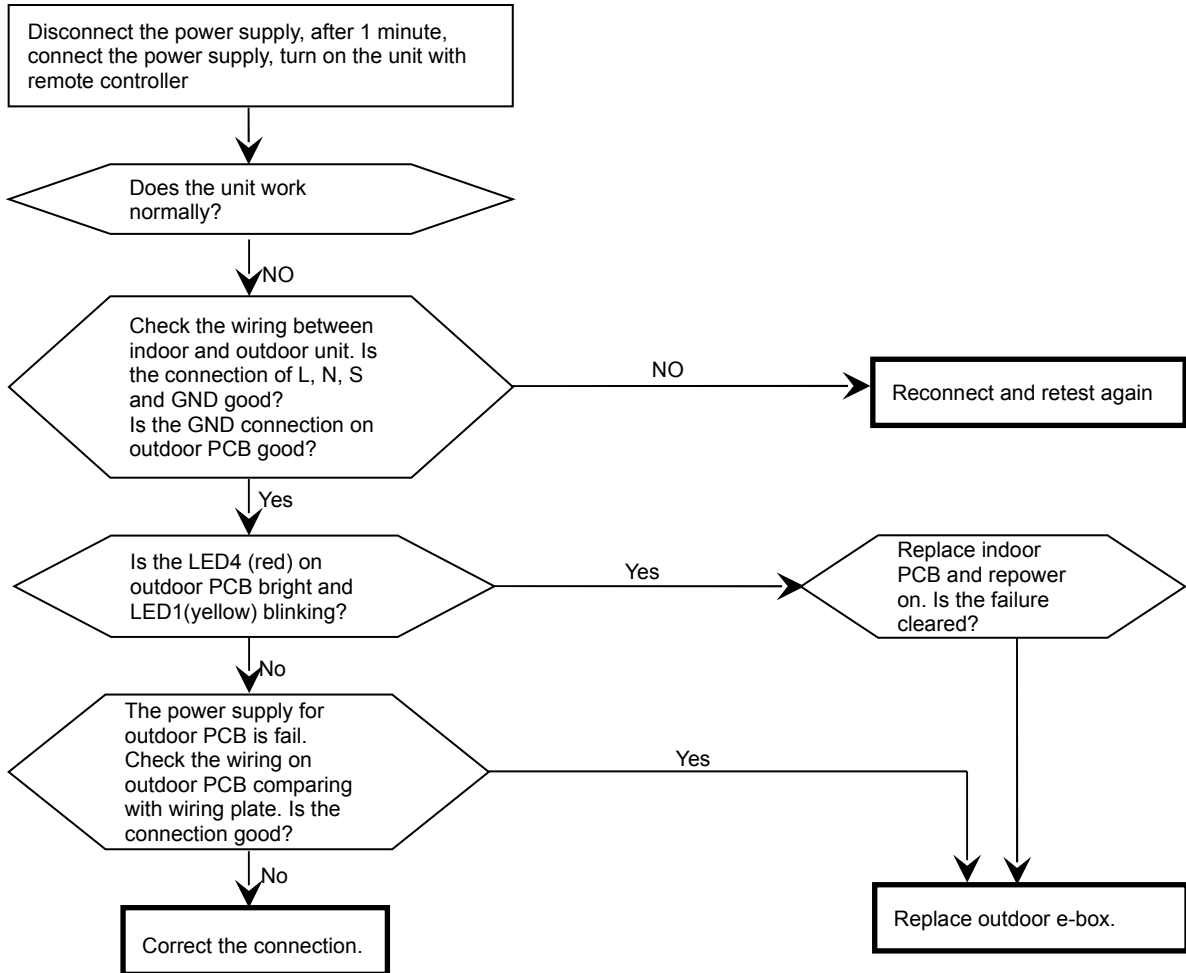

### 10.2.3 E2(zero-crossing signal error) diagnosis and solution

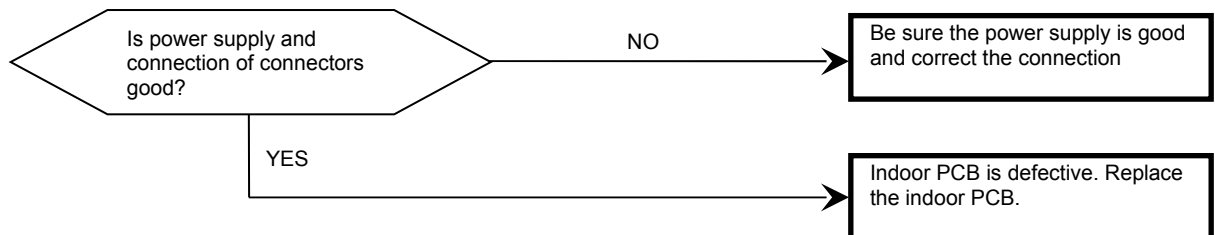

10.2.4 E3(indoor fan speed out of control) diagnosis and solution

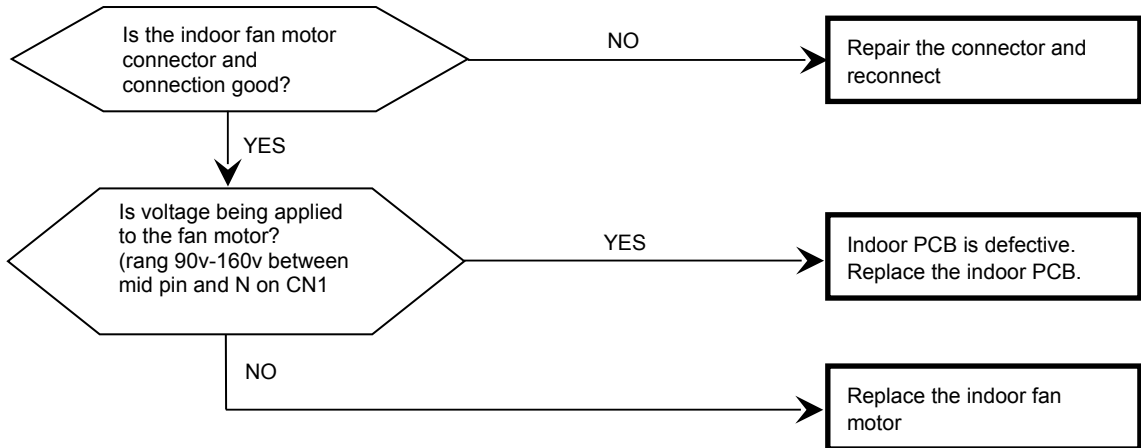

10.2.5 E5(Open or short circuit of outdoor temperature sensor) diagnosis and solution.

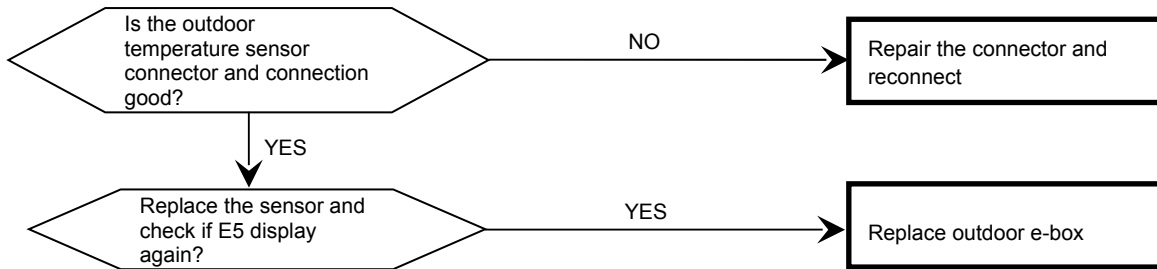

10.2.6 E6(open or short circuit of room or evaporator temperature sensor) diagnosis and solution.

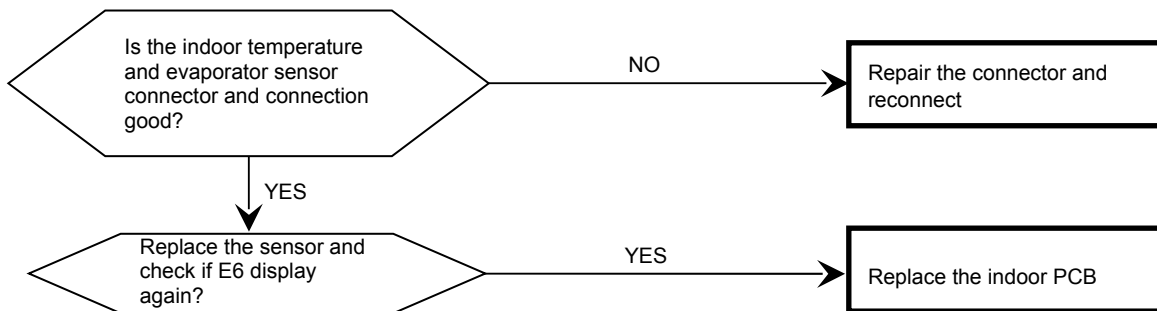

10.2.7 P0(Inverter module over-strong current protection) diagnosis and solution.

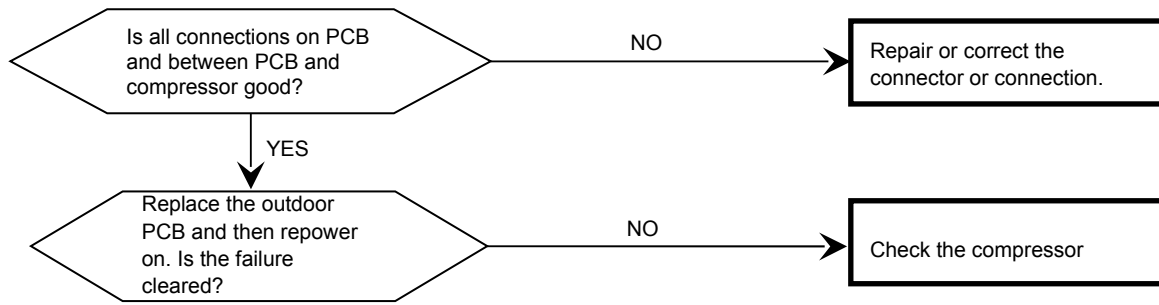

10.2.8 P1(over voltage or too low voltage protection) diagnosis and solution.

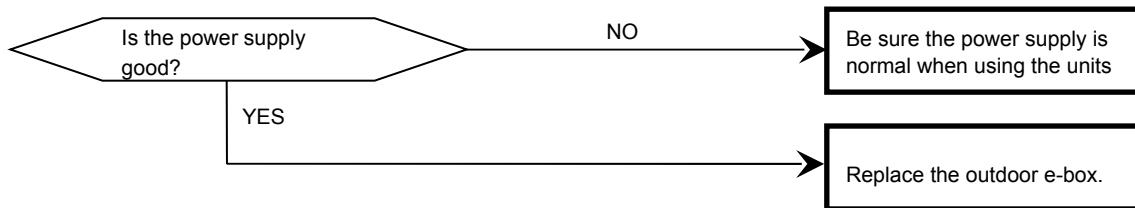

10.2.9 P2(temperature protection of compressor top) diagnosis and solution.

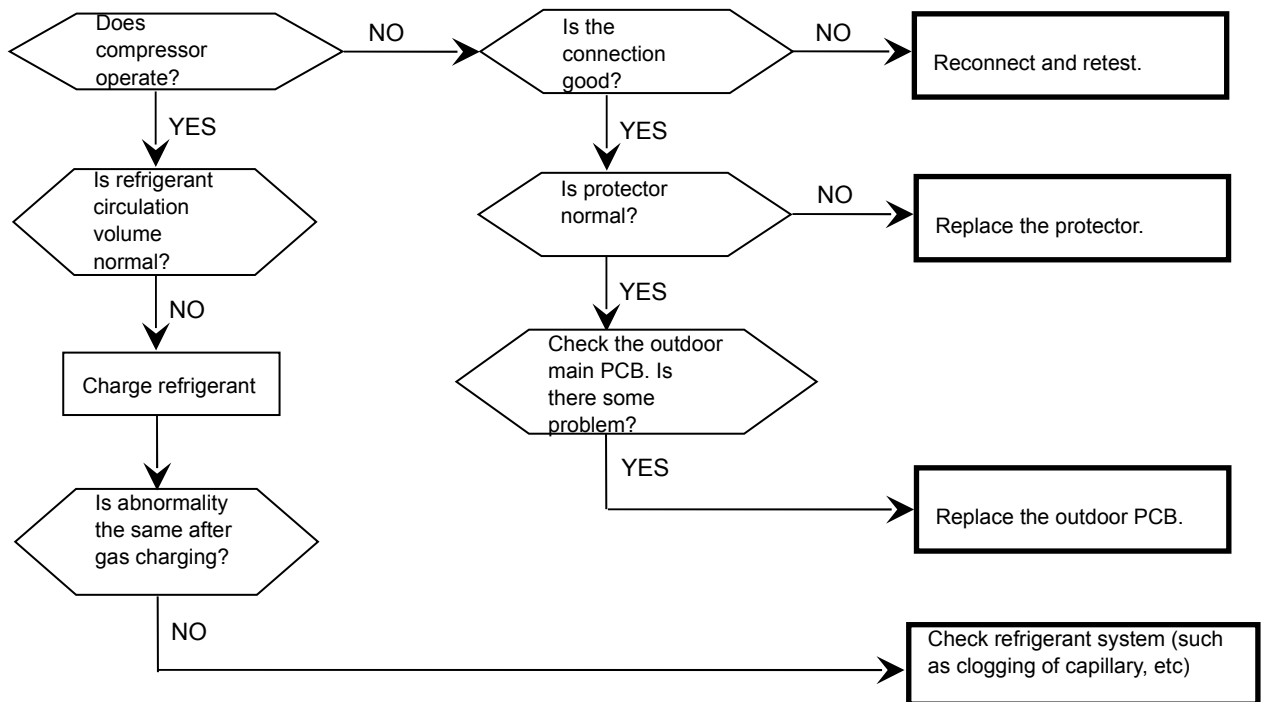

### 10.2.10 P4(inverter compressor drive error) diagnosis and solution.

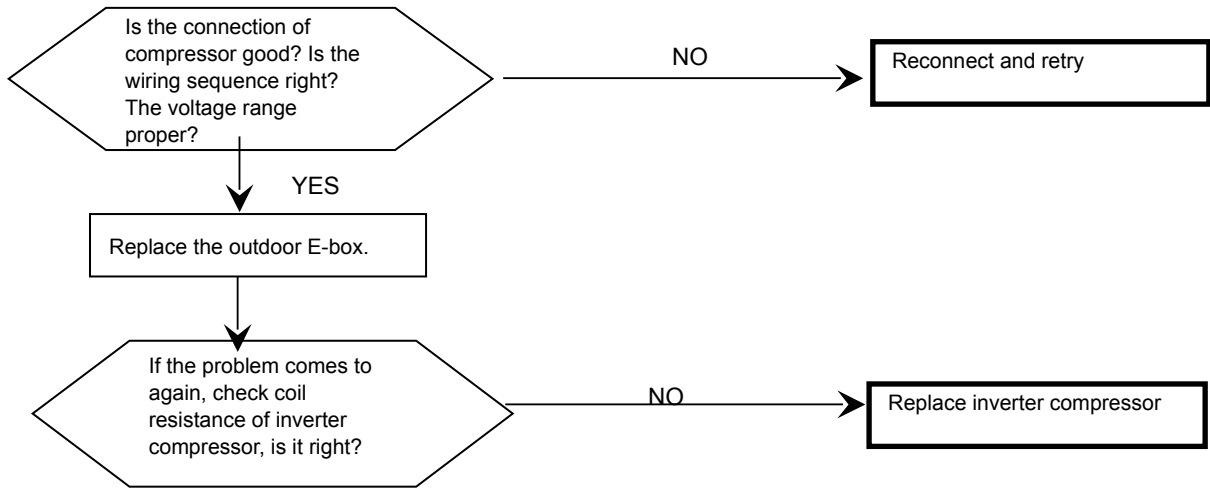

## 10.3 Key parts checking.

### 10.3.1. Compressor checking (Model: DA130S1C-20FZ)..

Measure the resistance value of each winding by using the multi-meter.

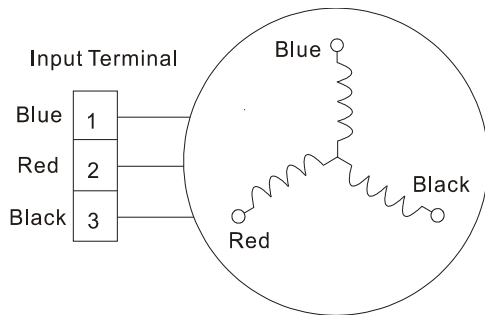

Position	Resistance Value
Blue - Red	0.95Ω (20□)
Blue - Black	
Red - Blue	

### 10.3.2 Outdoor Fan Motor (Model: YDK24-6G).

Measure the resistance value of each winding by using the multi-meter.

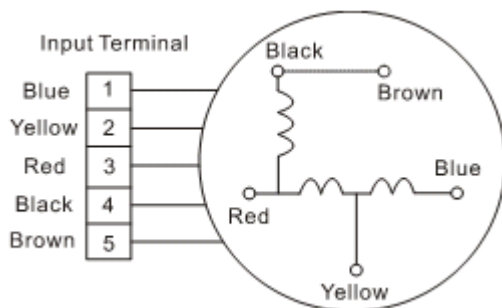

Position	Resistance Value
Black - Red	372Ω±8% (20□)
Red -Yellow	249Ω±8% (20□)
Yellow - Blue	249Ω ±8% (20□)

10.3.3 Indoor Fan Motor (Model: RPG28D).

Measure the resistance value of each winding by using the multi-meter.

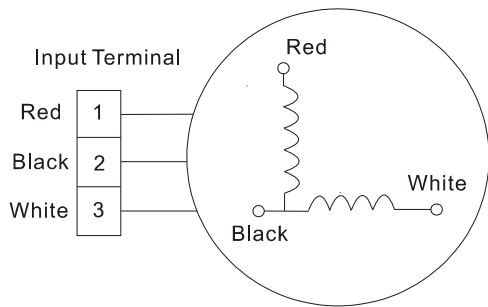

Position	Resistance Value
Black - Red	260Ω±8% (20Ω)
White - Black	385Ω±8% (20Ω)

10.3.4 Temperature Sensors.

- Room temp.(T1) sensor,
- Indoor coil temp.(T2) sensor,
- Outdoor coil temp.(T3) sensor,
- Outdoor ambient temp.(T4) sensor,
- Compressor exhaust temp.(Te) sensor.

Measure the resistance value of each winding by using the multi-meter.

Some frequently-used R-T data for T1, T2, T3 and T4 sensor:

Temperature (°C)	5	10	15	20	25	30	40	50	60
Resistance Value (KΩ)	26.9	20.7	16.1	12.6	10	8	5.2	3.5	2.4

Some frequently-used R-T data for Te sensor:

Temperature (°F)	5	15	25	35	60	70	80	90	100
Resistance Value (KΩ)	141.6	88	56.1	36.6	13.8	9.7	6.9	5	3.7

