

R INVERTER SERIES

Service Manual 2012

CONTENTS

1. Precaution	1
1.1 Safety Precaution.....	1
1.2 Warning	1
2. Function	5
3. Dimension	6
3.1 Indoor Unit.....	6
3.2 Outdoor Unit.....	7
4. Refrigerant Cycle Diagram	8
5. Wiring Diagram	9
5.1 Indoor Unit.....	9
5.2 Outdoor Unit.....	11
6 Installation Details	13
6.1 Wrench torque sheet for installation	13
6.2 Connecting the cables	13
6.3 Pipe length and the elevation	14
6.4 Installation for the first time	15
6.5 Adding the refrigerant after running the system for many years	18
6.6 Re-installation while the indoor unit need to be repaired	19
6.7 Re-installation while the outdoor unit need to be repaired	21
7. Operation characteristics	24
8. Electronic function	25
8.1 Abbreviation	25
8.2 Display function.....	25
8.3 Main Protection	26
8.4 Operation Modes and Functions.....	27
9. Troubleshooting	39
9.1 Indoor Unit Error Display.....	39
9.2 Diagnosis and Solution	40

1. Precaution

1.1 Safety Precaution

- **To prevent injury to the user or other people and property damage, the following instructions must be followed.**
- **Incorrect operation due to ignoring instruction will cause harm or damage.**
- **Before service the unit, be sure to read this service manual at first.**

1.2 Warning

➤ Installation

- **Do not use a defective or underrated circuit breaker. Use this appliance on a dedicated circuit.**

There is risk of fire or electric shock.

- **For electrical work, contact the dealer, seller, a qualified electrician, or an authorized service center.**

Do not disassemble or repair the product, there is risk of fire or electric shock.

- **Always ground the product.**

There is risk of fire or electric shock.

- **Install the panel and the cover of control box securely.**

There is risk of fire of electric shock.

- **Always install a dedicated circuit and breaker.**

Improper wiring or installation may cause fore or electric shock.

- **Use the correctly rated breaker of fuse.**

There is risk of fire or electric shock.

- **Do not modify or extend the power cable.**

There is risk of fire or electric shock.

- **Do not install, remove, or reinstall the unit by yourself (customer).**

There is risk of fire, electric shock, explosion, or injury.

- **Be caution when unpacking and installing the product.**

Sharp edges could cause injury, be especially careful of the case edges and the fins on the

condenser and evaporator.

- **For installation, always contact the dealer or an authorized service center.**
- **Do not install the product on a defective installation stand.**
- **Be sure the installation area does not deteriorate with age.**

If the base collapses, the air conditioner could fall with it, causing property damage, product failure, and personal injury.

- **Do not let the air conditioner run for a long time when the humidity is very high and a door or a window is left open.**

- **Take care to ensure that power cable could not be pulled out or damaged during operation.**

There is risk of fire or electric shock.

- **Do not place anything on the power cable.**

There is risk of fire or electric shock.

- **Do not plug or unplug the power supply plug during operation.**

There is risk of fire or electric shock.

- **Do not touch (operation) the product with wet hands.**

- **Do not place a heater or other appliance near the power cable.**

There is risk of fire and electric shock.

- **Do not allow water to run into electrical parts.**

It may cause fire, failure of the product, or electric shock.

- **Do not store or use flammable gas or combustible near the product.**

There is risk of fire or failure of product.

- **Do not use the product in a tightly closed space for a long time.**

Oxygen deficiency could occur.

- **When flammable gas leaks, turn off the gas and open a window for ventilation before turn the product on.**

- **If strange sounds or smoke comes from product, turn the breaker off or disconnect the power supply cable.**

There is risk of electric shock or fire.

- **Stop operation and close the window in storm or hurricane. If possible, remove the product from the window before the hurricane arrives.**

There is risk of property damage, failure of product, or electric shock.

- **Do not open the inlet grill of the product during operation. (Do not touch the electrostatic filter, if the unit is so equipped.)**

There is risk of physical injury, electric shock, or product failure.

- **When the product is soaked, contact an authorized service center.**

There is risk of fire or electric shock.

- **Be caution that water could not enter the product.**

There is risk of fire, electric shock, or product damage.

- **Ventilate the product from time to time when operating it together with a stove etc.**

There is risk of fire or electric shock.

- **Turn the main power off when cleaning or maintaining the product.**

There is risk of electric shock.

- **When the product is not be used for a long time, disconnect the power supply plug or turn off the breaker.**

There is risk of product damage or failure, or unintended operation.

- **Take care to ensure that nobody could step on or fall onto the outdoor unit.**

This could result in personal injury and product damage.

➤ CAUTION

- **Always check for gas (refrigerant) leakage after installation or repair of product.**

Low refrigerant levels may cause failure of product.

- **Install the drain hose to ensure that water is drained away properly.**

A bad connection may cause water leakage.

- **Keep level even when installing the product.**

It can avoid vibration of water leakage.

- **Do not install the product where the noise or hot air from the outdoor unit could damage the neighborhoods.**

It may cause a problem for your neighbors.

- **Use two or more people to lift and transport the product.**

- **Do not install the product where it will be exposed to sea wind (salt spray) directly.**

It may cause corrosion on the product. Corrosion, particularly on the condenser and evaporator fins,

could cause product malfunction or inefficient operation.

➤ **Operational**

- **Do not expose the skin directly to cool air for long time. (Do not sit in the draft).**
- **Do not use the product for special purposes, such as preserving foods, works of art etc.**

It is a consumer air conditioner, not a precision refrigerant system.

There is risk of damage or loss of property.

- **Do not block the inlet or outlet of air flow.**
- **Use a soft cloth to clean. Do not use harsh detergents, solvents, etc.**

There is risk of fire, electric shock, or damage to the plastic parts of the product.

■ **Do not touch the metal parts of the product when removing the air filter. They are very sharp.**

- **Do not step on or put anything on the product. (outdoor units)**
- **Always insert the filter securely. Clean the filter every two weeks or more often if**

necessary.

A dirty filter reduces the efficiency of the air conditioner and could cause product malfunction or damage.

■ **Do not insert hands or other objects through air inlet or outlet while the product is operated.**

- **Do not drink the water drained from the product.**
- **Use a firm stool or ladder when cleaning or maintaining the product.**

Be careful and avoid personal injury.

■ **Replace the all batteries in the remote control with new ones of the same type. Do not mix old and new batteries or different types of batteries.**

There is risk of fire or explosion.

- **Do not recharge or disassemble the batteries. Do not dispose of batteries in a fire.**

They may burn or explode.

■ **If the liquid from the batteries gets onto your skin or clothes, wash it well with clean water. Do not use the remote if the batteries have leaked.**

2. Function

Model Names of Indoor/Outdoor Units

DC Inverter	Capacity	Indoor units	Outdoor units
	9k	MSR1i-09HRDN1	MOAi-09HDN1
	12k	MSR1i-12HRDN1	MOBi-12HDN1
	18k	MSR1i-18HRDN1	MOC2i-18HDN1

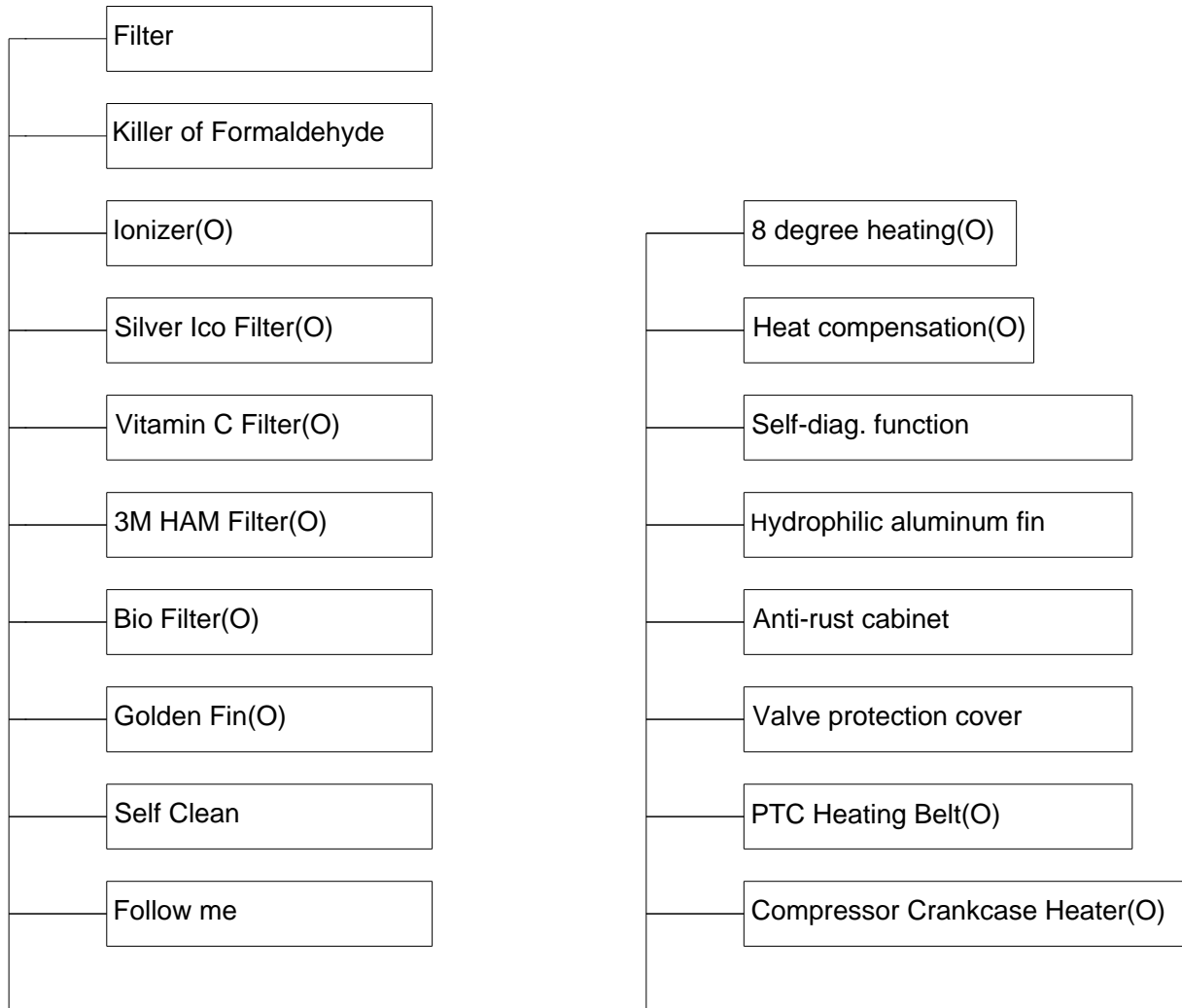

O: optional function

3. Dimension

3.1 Indoor Unit

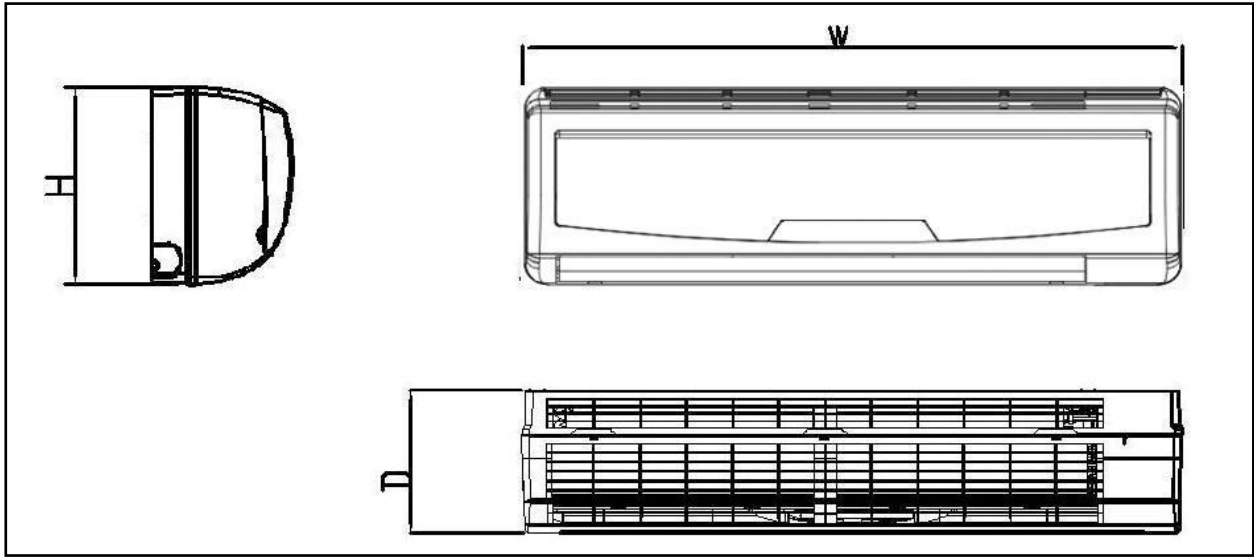

Model	W	D	H
MSR1i-09HRDN1	710	189	250
MSR1i-12HRDN1	790	196	275
MSR1i-18HRDN1	930	198	275

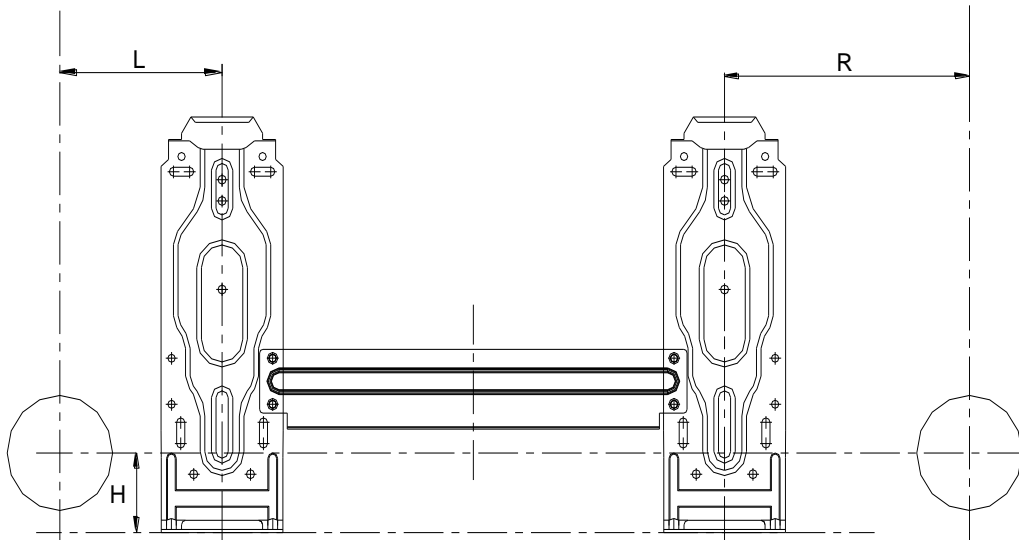

Model	R(mm)	L(mm)	H(mm)	Dimension of installation hole(mm)
MSR1i-09HRDN1	111.5	100	45	65
MSR1i-12HRDN1	83.5	100	45	
MSR1i-18HRDN1	207	150	45	

3.2 Outdoor Unit

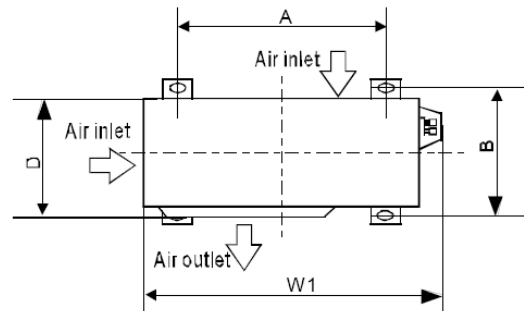
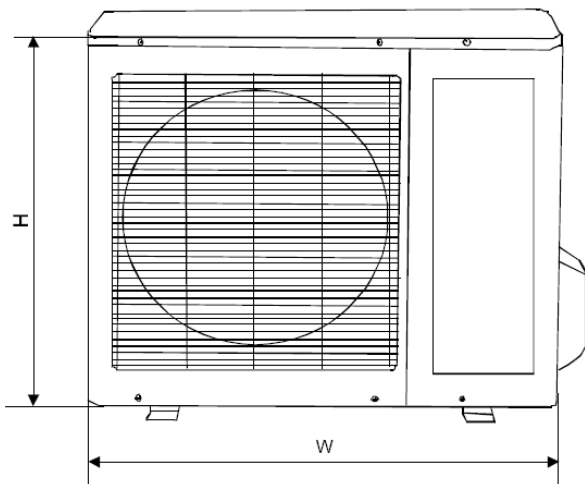
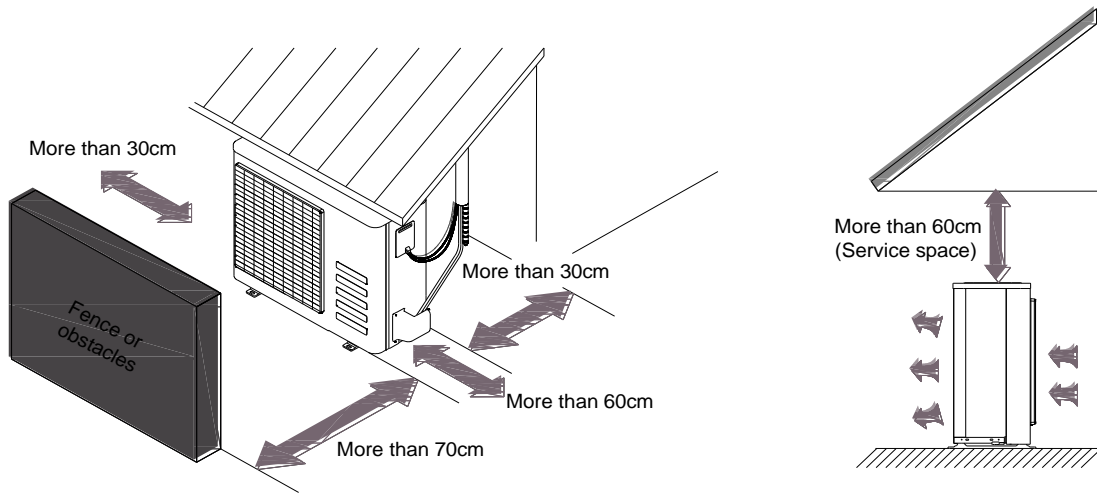

Model	W	D	H	W1	A	B
MOAi-09HDN1	700	240	540	757	458	250
MOBi-12HDN1	780	250	540	843	549	276
MOC2i-18HDN1	760	285	590	823	530	290

4. Refrigerant Cycle Diagram

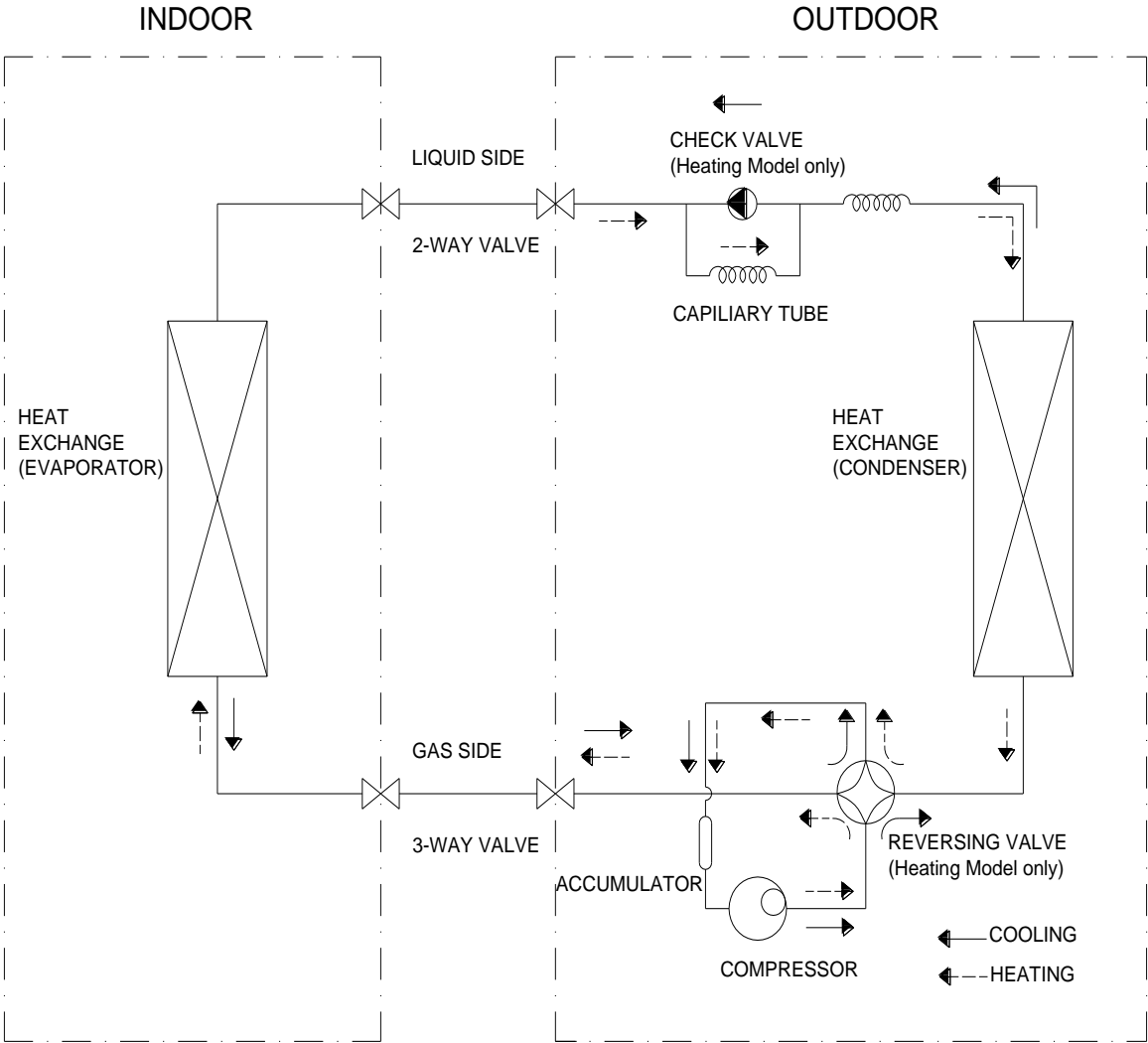

5. Wiring Diagram

5.1 Indoor Unit

MSR1i-09HRDN1, MSR1i-12HRDN1

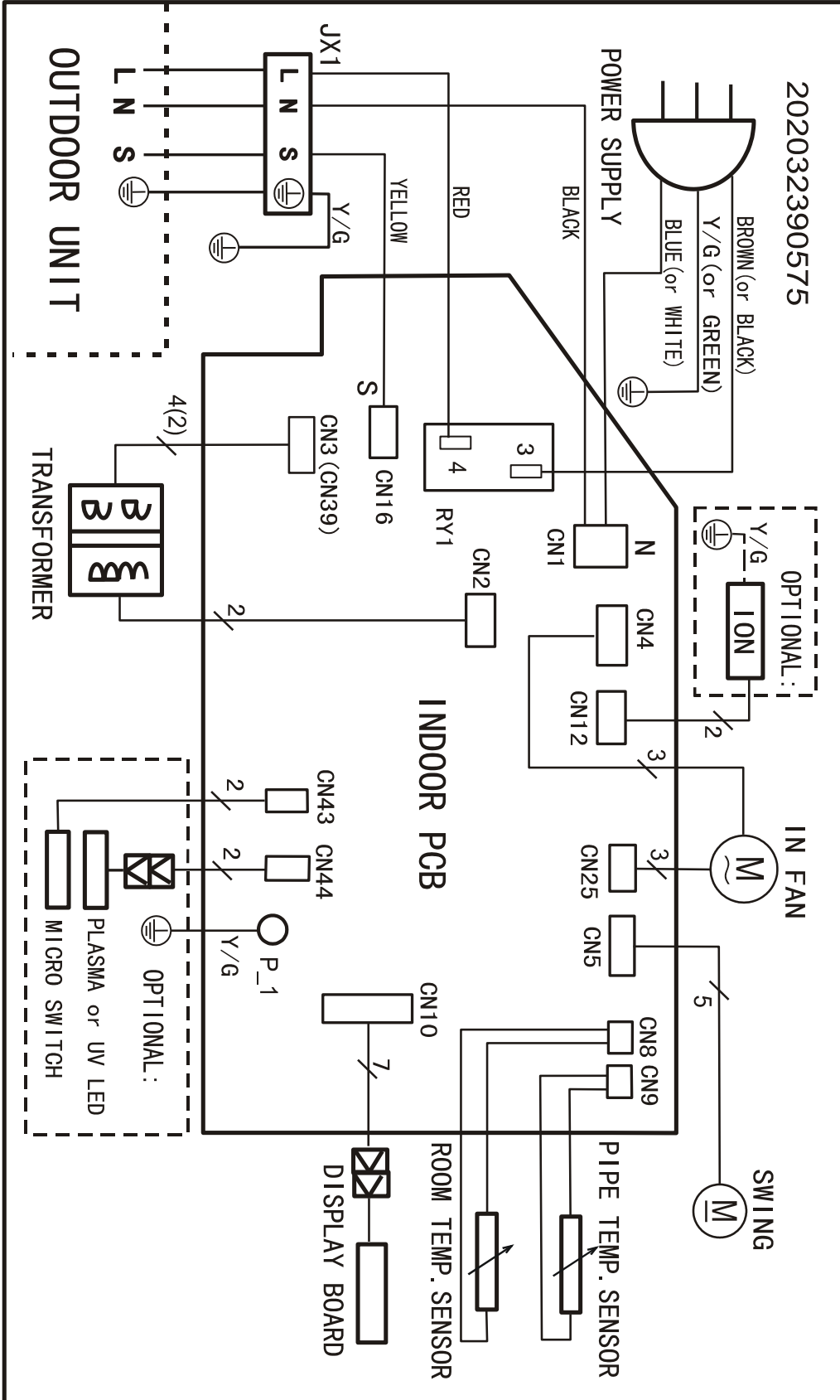

MSR1i-18HRDN1

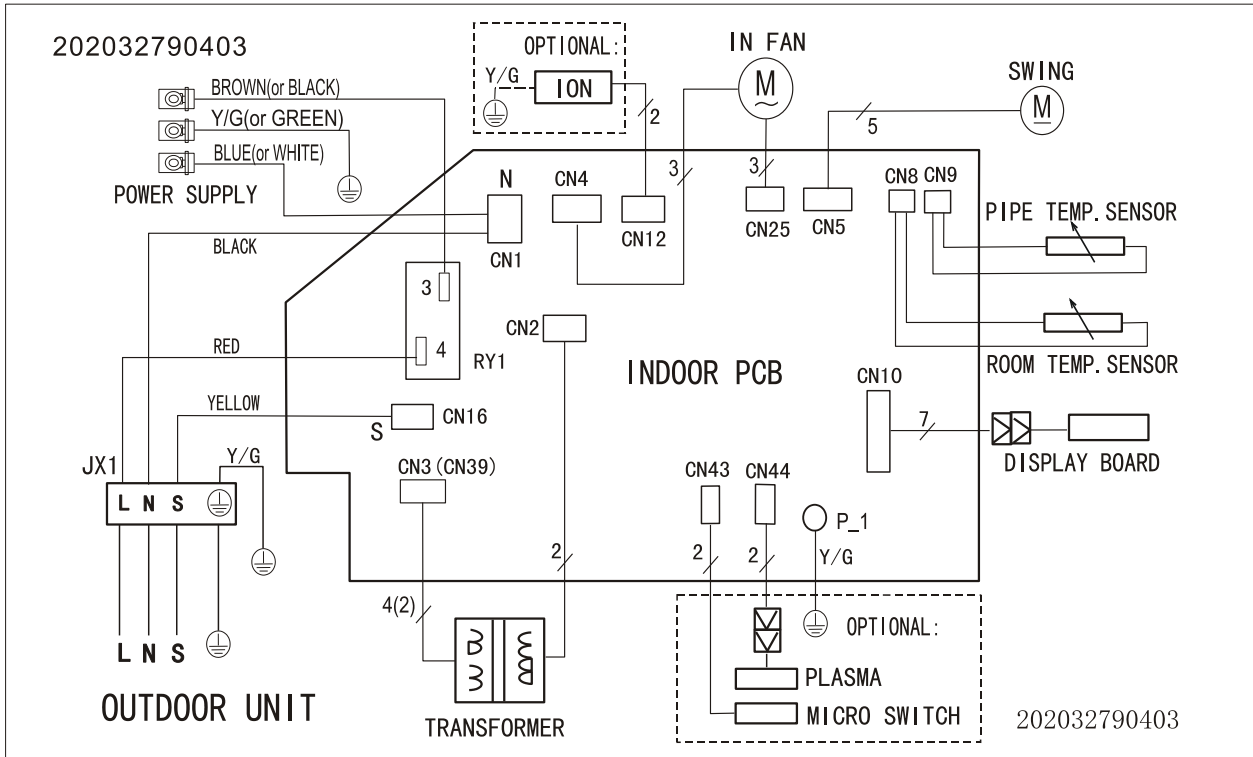

5.2 Outdoor Unit

MOAi-09HDN1, MOBi-12HDN1

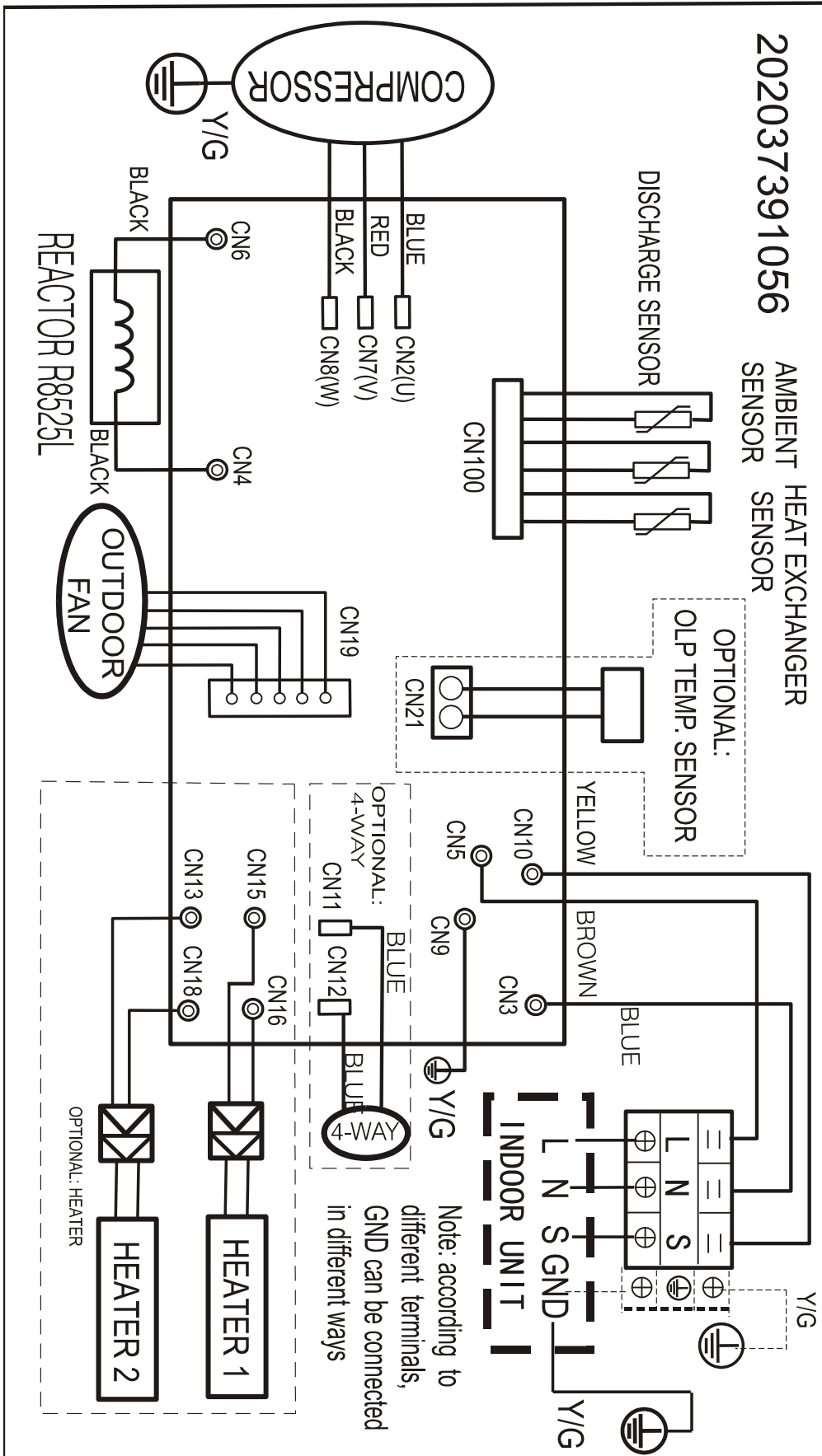

MOC2i-18HDN1

202037790069

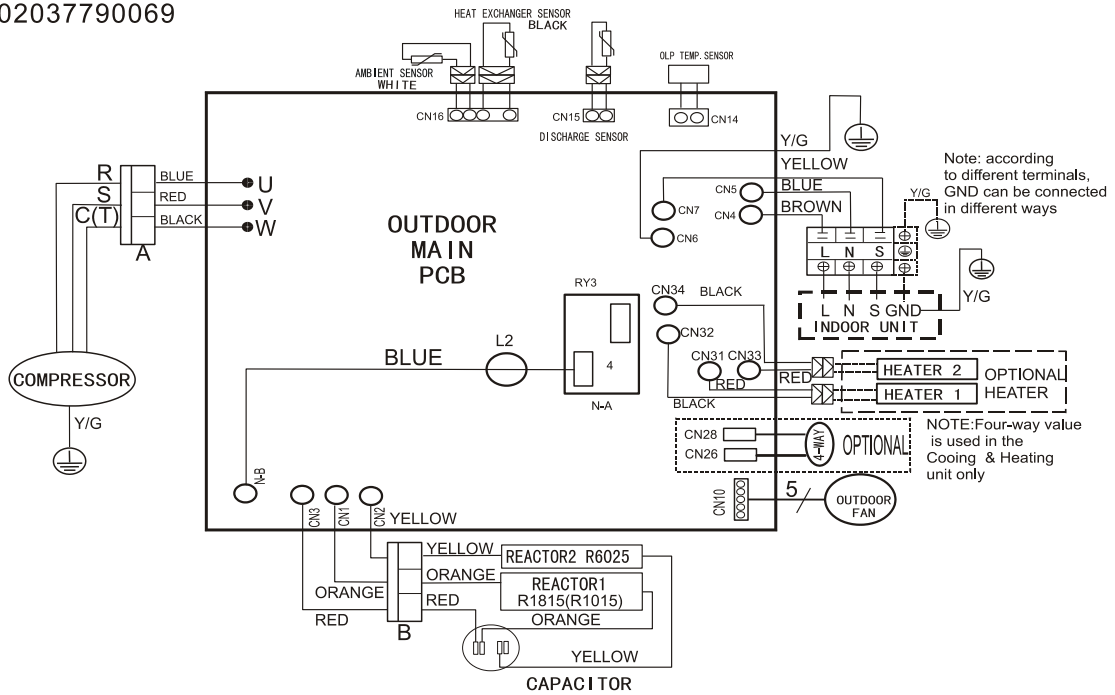

6 Installation Details

6.1 Wrench torque sheet for installation

Outside diameter		Torque	Additional tightening torque
mm	inch	N.cm	N.cm
Φ6.35	1/4	1500(153kgf.cm)	1600(163kgf.cm)
Φ9.52	3/8	2500(255kgf.cm)	2600(265kgf.cm)
Φ12.7	1/2	3500(357kgf.cm)	3600(367kgf.cm)
Φ16	5/8	4500(459kgf.cm)	4700(479kgf.cm)
Φ19	3/4	6500(663kgf.cm)	6700(683kgf.cm)

6.2 Connecting the cables

The power cord of connect should be selected according to the following specifications sheet.

Rated current of appliance	Nominal cross-sectional area (mm ²)
>3 and ≤6	0.75
>6 and ≤10	1
>10 and ≤16	1.5
>16 and ≤25	2.5

The cable size and the current of the fuse or switch are determined by the maximum current indicated on the nameplate which located on the side panel of the unit. Please refer to the nameplate before selecting the cable, fuse and switch.

6.3 Pipe length and the elevation

The pipe length and refrigerant amount:

Model	Pipe size		Standard length (m)	Max. Length A (m)	Max. Elevation B (m)	Additional refrigerant (g/m)
	Gas	Liquid				
MSR1i-09HRDN1 + MOAi-09HDN1	3/8" (Φ9.52)	1/4" (Φ6.35)	5	20	8	20
MSR1i-12HRDN1 + MOBi-12HDN1						
MSR1i-18HRDN1 + MOC2i-18HDN1	1/2" (Φ12.7)	1/4" (Φ6.35)	5	25	10	20

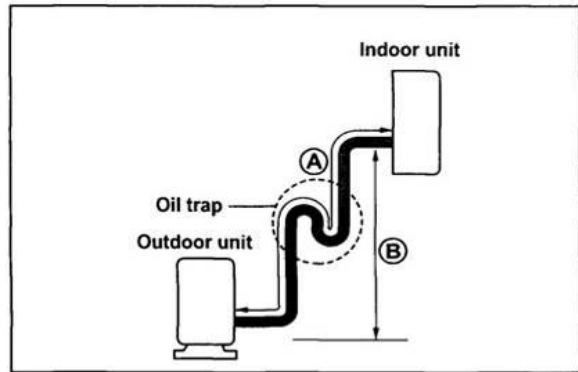
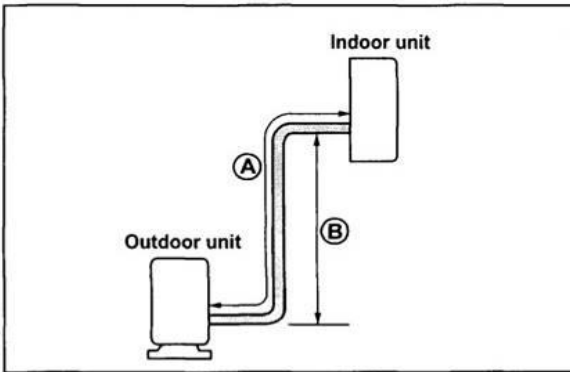

Caution:

The capacity test is based on the standard length and the maximum permissible length is based on the system reliability.

The oil trap should be installed per 5-7 meters.

6.4 Installation for the first time

Air and moisture in the refrigerant system have undesirable effects as below:

- Pressure in the system rises.
- Operating current rises.
- Cooling or heating efficiency drops.
- Moisture in the refrigerant circuit may freeze and block capillary tubing.
- Water may lead to corrosion of parts in the refrigerant system.

Therefore, the indoor units and the pipes between indoor and outdoor units must be leak tested and evacuated to remove gas and moisture from the system.

Gas leak check (Soap water method):

Apply soap water or a liquid neutral detergent on the indoor unit connections or outdoor unit connections by a soft brush to check for leakage of the connecting points of the piping. If bubbles come out, the pipes have leakage.

1. Air purging with vacuum pump

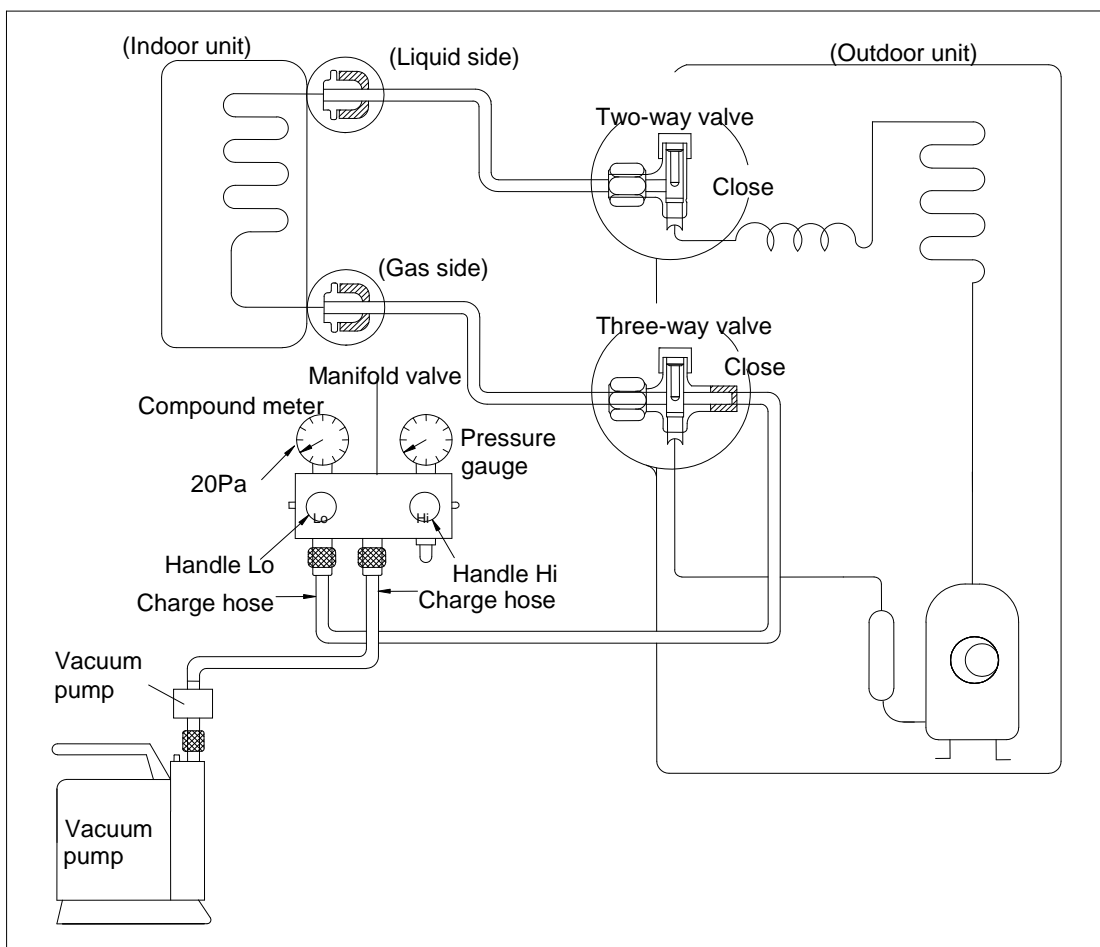

- 1) Completely tighten the flare nuts of the indoor and outdoor units, confirm that both the 2-way and 3-way valves are set to the closed position.
- 2) Connect the charge hose with the push pin of handle lo to the 3-way valves gas service port..
- 3) Connect the charge hose of handle hi connection to the vacuum pump.
- 4) Fully open the handle Lo of the manifold valve.
- 5) Operate the vacuum pump to evacuate.
- 6) Make evacuation for 30 minutes and check whether the compound meter indicates -0.1Mpa. If

the meter does not indicate -0.1Mpa after pumping 30 minutes, it should be pumped 20 minutes more. If the pressure can't achieve -0.1Mpa after pumping 50 minutes, please check if there are some leakage points.

Fully close the handle Lo valve of the manifold valve and stop the operation of the vacuum pump. Confirm that the gauge needle does not move (approximately 5 minutes after turning off the vacuum pump).

7) Turn the flare nut of the 3-way valves about 45° counterclockwise for 6 or 7seconds after the gas coming out, then tighten the flare nut again. Make sure the pressure display in the pressure indicator is a little higher than the atmosphere pressure. Then remove the charge hose from the 3 way valve.

8) Fully open the 2 way valve and 3 way valve and securely tighten the cap of the 3 way valve.

2. Air purging by refrigerant

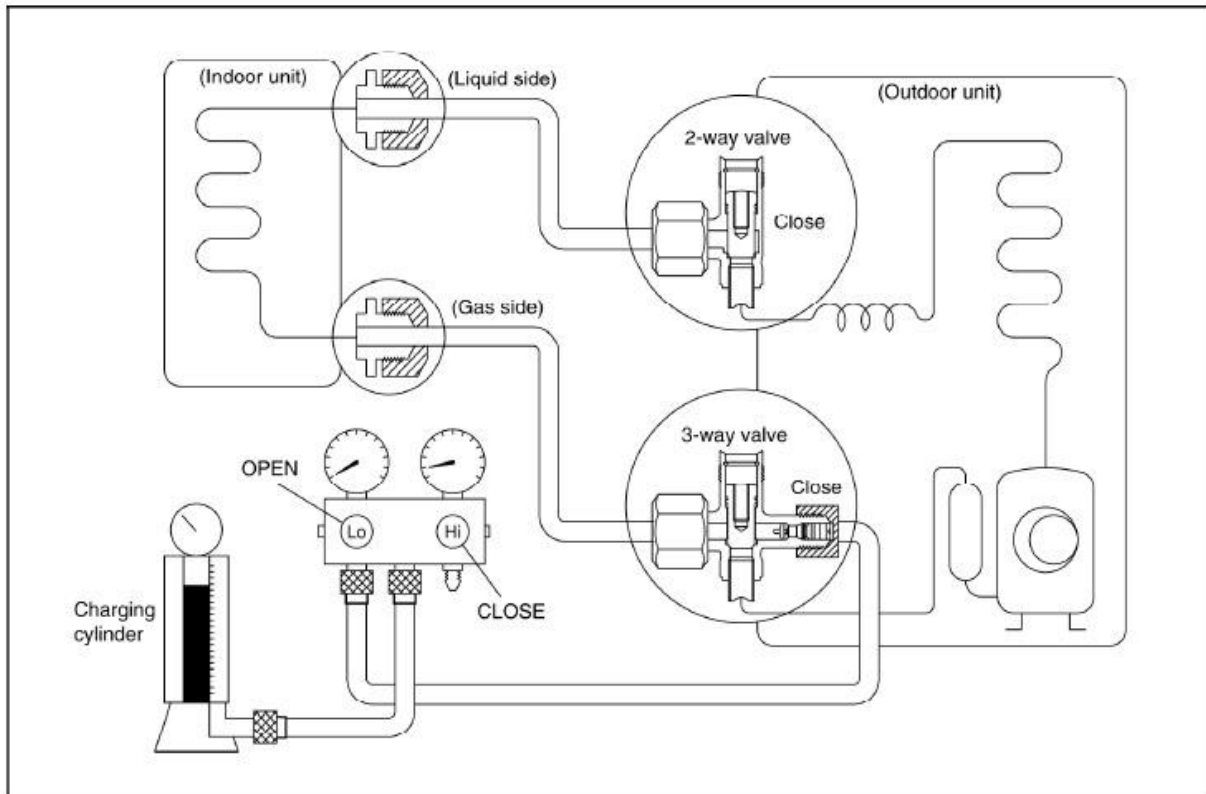

Procedure:

1). Confirm that both the 2-way and 3-way valves are set to the closed position.

2). Connect the charge set and a charging cylinder to the service port of the 3-way valve.

3). Air purging.

Open the valves on the charging cylinder and the charge set. Purge the air by loosening the flare nut on the 2-way valve approximately 45° for 3 seconds then closing it for 1 minute; repeat 3 times.

After purging the air, use a torque wrench to tighten the flare nut on the 2-way valve.

4). Check the gas leakage.

Check the flare connections for gas leakage.

5). Discharge the refrigerant.

Close the valve on the charging cylinder and discharge the refrigerant by loosening the flare nut on the 2-way valve approximately 45° until the gauge indicates 0.3 to 0.5 Mpa.

6). Disconnect the charge set and the charging cylinder, and set the 2-way and 3-way valves to the open position.

Be sure to use a hexagonal wrench to operate the valve stems.

7). Mount the valve stems nuts and the service port cap.

Be sure to use a torque wrench to tighten the service port cap to a torque 18N·m.

Be sure to check the gas leakage.

3. Adding the refrigerant if the pipe length >5m

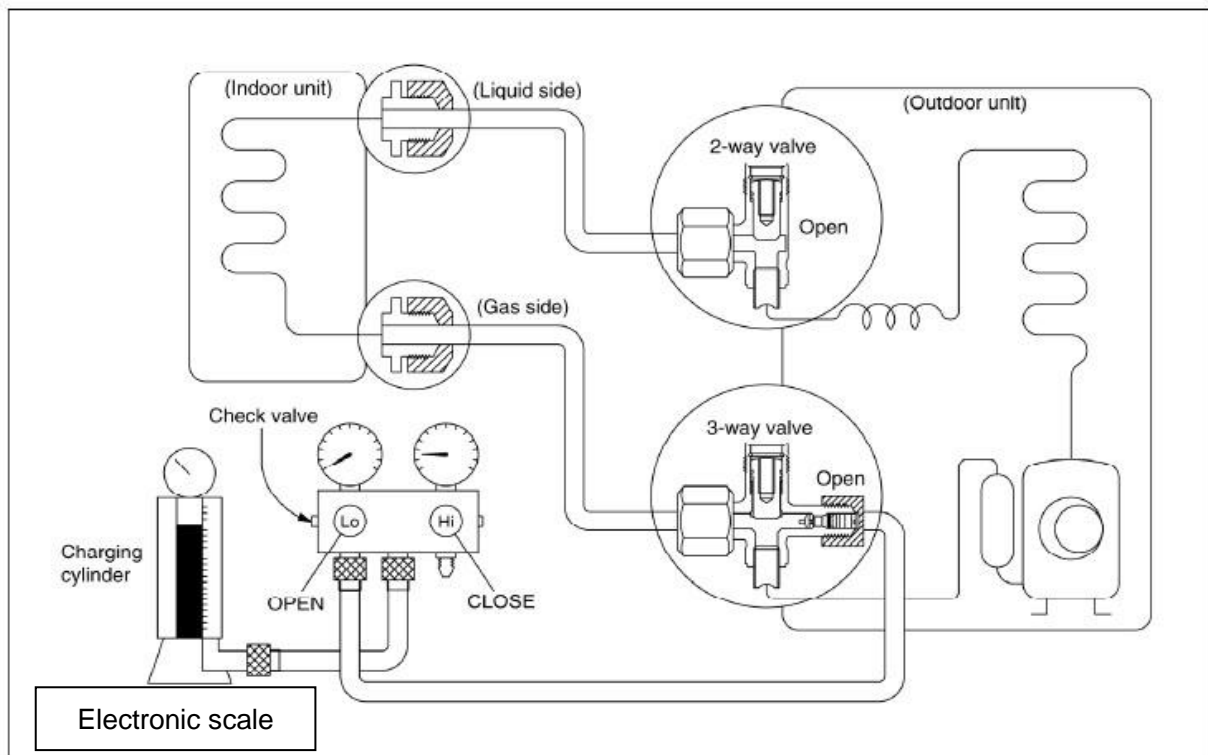

Procedure:

1). Connect the charge hose to the charging cylinder, open the 2-way valve and the 3-way valve.

Connect the charge hose which you disconnected from the vacuum pump to the valve at the bottom of the cylinder. If the refrigerant is R410A, make the cylinder bottom up to ensure the liquid charge.

2). Purge the air from the charge hose.

Open the valve at the bottom of the cylinder and press the check valve on the charge set to purge the air (be careful of the liquid refrigerant).

3) Put the charging cylinder onto the electronic scale and record the weight.

4) Operate the air conditioner at the cooling mode.

5) Open the valves (Low side) on the charge set and charge the system with liquid refrigerant.

6).When the electronic scale displays the proper weight (refer to the table), disconnect the charge hose from the 3-way valve's service port immediately and turn off the air conditioner before disconnecting the hose.

7). Mount the valve stem caps and the service port

Use torque wrench to tighten the service port cap to a torque of 18N.m.

Be sure to check for gas leakage.

6.5 Adding the refrigerant after running the system for many years

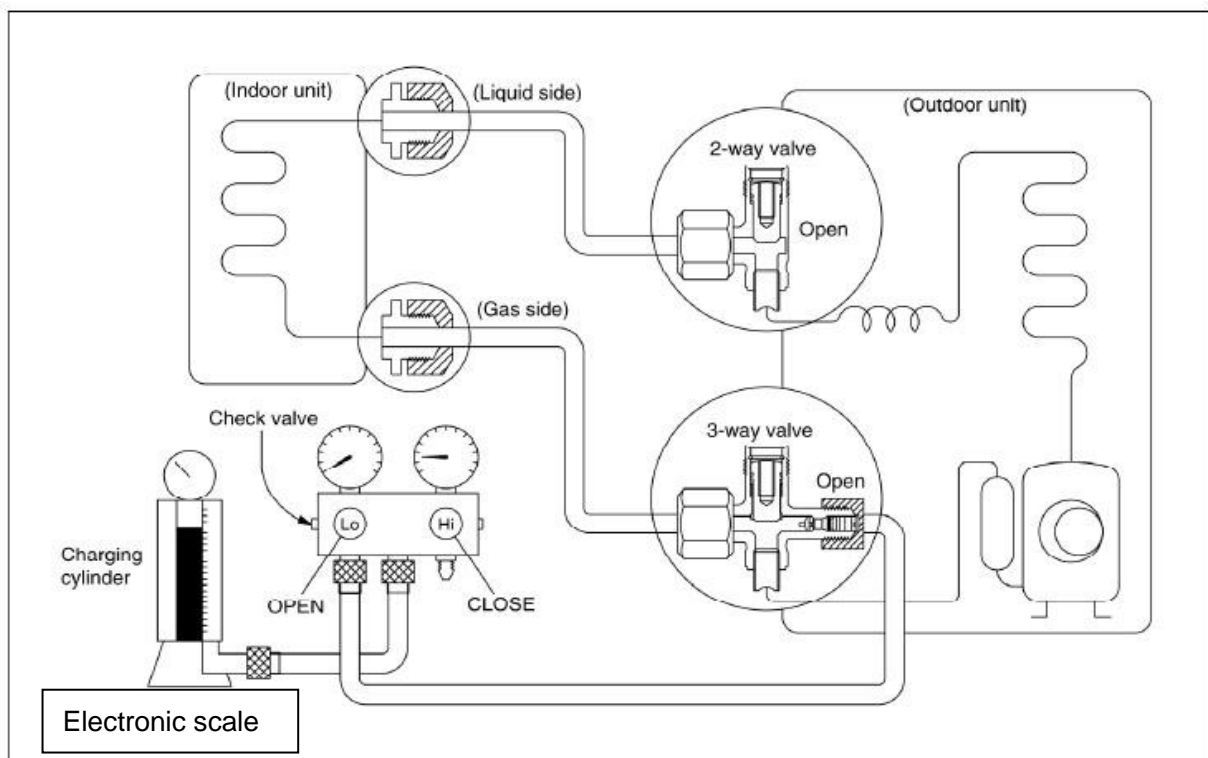

Procedure:

1). Connect the charge hose to the 3-way service port, open the 2-way valve and the 3-way valve.

Connect the charge hose to the valve at the bottom of the cylinder. If the refrigerant is R410A, make the cylinder bottom up to ensure liquid charge.

2). Purge the air from the charge hose.

Open the valve at the bottom of the cylinder and press the check valve on the charge set to purge the air (be careful of the liquid refrigerant).

3) Put the charging cylinder onto the electronic scale and record the weight.

4) Operate the air conditioner at the cooling mode.

5) Open the valves (Low side) on the charge set and charge the system with liquid refrigerant.

6).When the electronic scale displays the proper weight (refer to the gauge and the pressure of the low side), disconnect the charge hose from the 3-way valve's service port immediately and turn off the air conditioner before disconnecting the hose.

7). Mount the valve stem caps and the service port

Use torque wrench to tighten the service port cap to a torque of 18N.m.

Be sure to check for gas leakage.

6.6 Re-installation while the indoor unit need to be repaired

1. Collecting the refrigerant into the outdoor unit

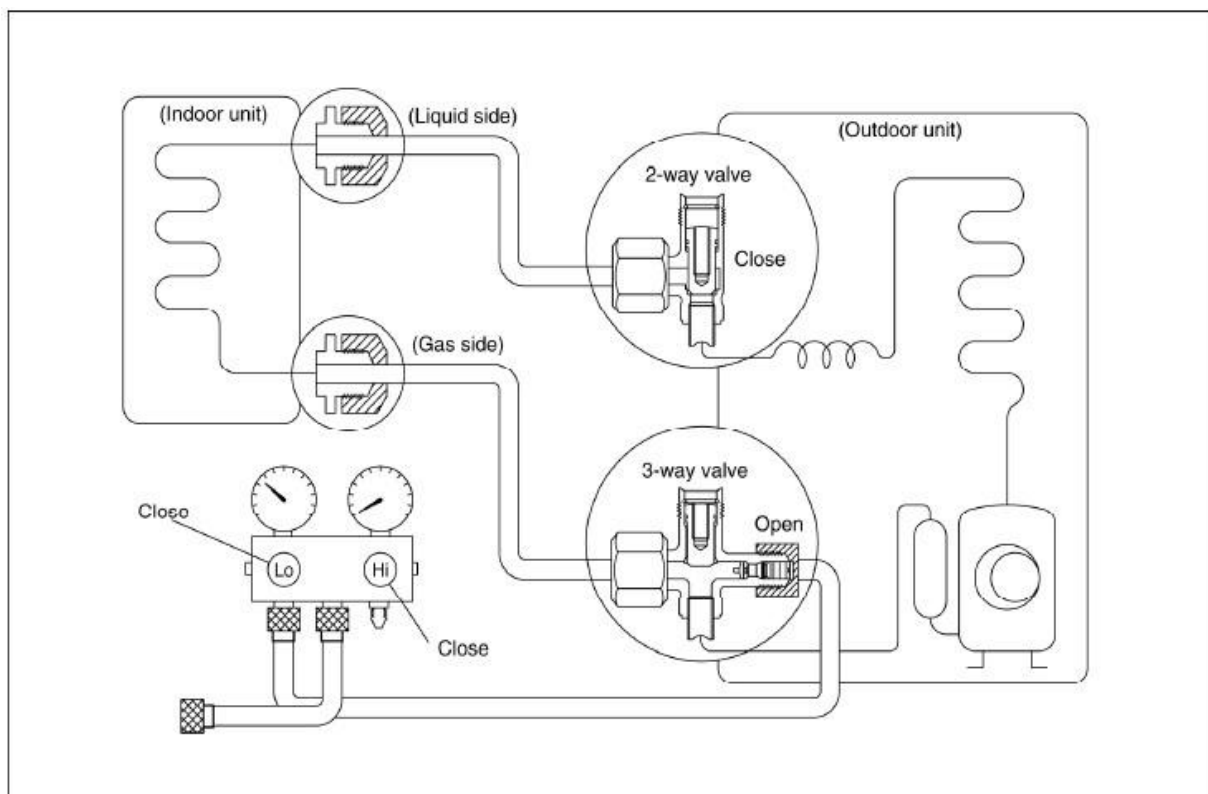

Procedure

1). Confirm that both the 2-way and 3-way valves are set to the opened position

Remove the valve stem caps and confirm that the valve stems are in the opened position.

Be sure to use a hexagonal wrench to operate the valve stems.

2). Connect the charge hose with the push pin of handle lo to the 3-way valves gas service port.

3). Air purging of the charge hose.

Open the handle Lo valve of the manifold valve slightly to purge air from the charge hose for 5 seconds and then close it quickly.

4). Set the 2-way valve to the close position.

5). Operate the air conditioner at the cooling cycle and stop it when the gauge indicates 0.1MPa.

6). Set the 3-way valve to the closed position immediately

Do this quickly so that the gauge ends up indicating 0.3 to 0.5Mpa.

Disconnect the charge set, and tighten the 2-way and 3-way valve's stem nuts.

Use a torque wrench to tighten the 3-way valves service port cap to a torque of 1.8 kgf.m.

Be sure to check for gas leakage.

2. Air purging by the refrigerant

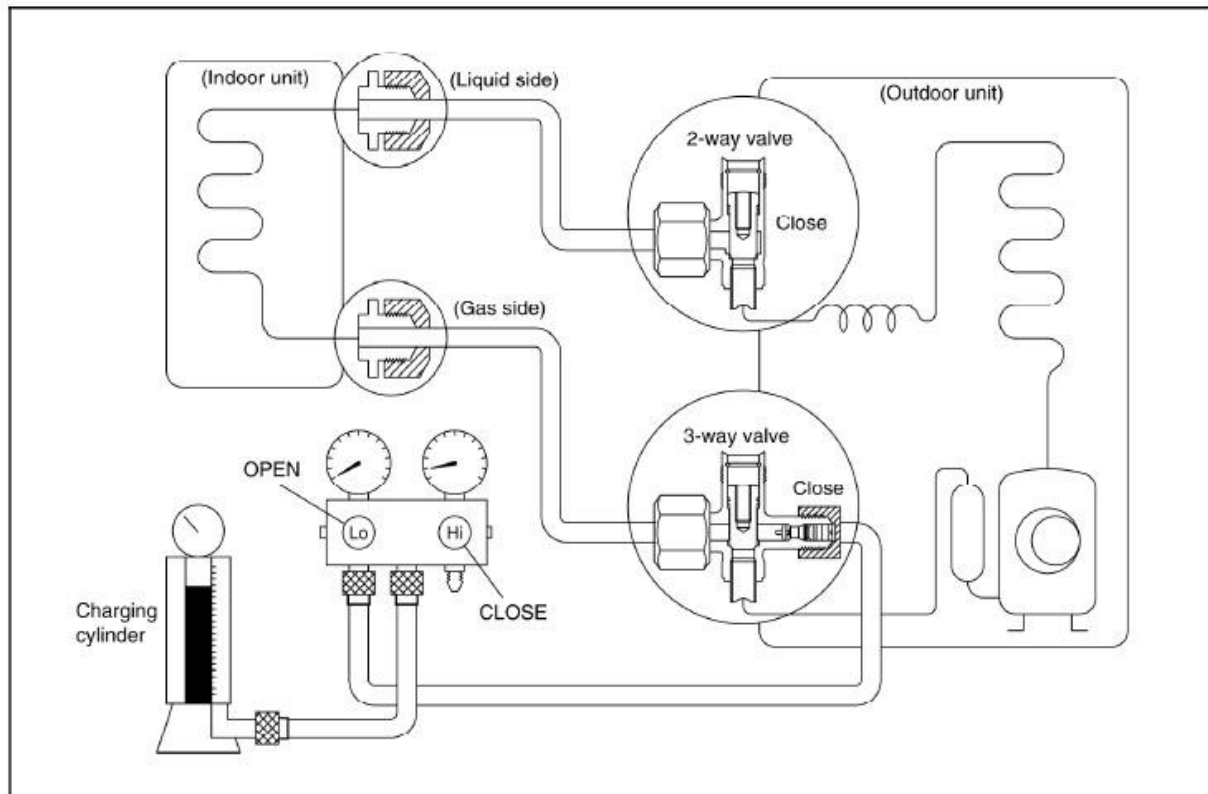

Procedure:

1). Confirm that both the 2-way and 3-way valves are set to the closed position.

2). Connect the charge set and a charging cylinder to the service port of the 3-way valve

Leave the valve on the charging cylinder closed.

3). Air purging.

Open the valves on the charging cylinder and the charge set. Purge the air by loosening the flare nut on the 2-way valve approximately 45° for 3 seconds then closing it for 1 minute; repeat 3 times.

After purging the air, use a torque wrench to tighten the flare nut on the 2-way valve.

4). Check the gas leakage

Check the flare connections for gas leakage.

5). Discharge the refrigerant.

Close the valve on the charging cylinder and discharge the refrigerant by loosening the flare nut on the 2-way valve approximately 45' until the gauge indicates 0.3 to 0.5 Mpa.

6). Disconnect the charge set and the charging cylinder, and set the 2-way and 3-way valves to the open position

Be sure to use a hexagonal wrench to operate the valve stems.

7). Mount the valve stems nuts and the service port cap

Be sure to use a torque wrench to tighten the service port cap to a torque 18N.m.

Be sure to check the gas leakage.

6.7 Re-installation while the outdoor unit need to be repaired

1. Evacuation for the whole system

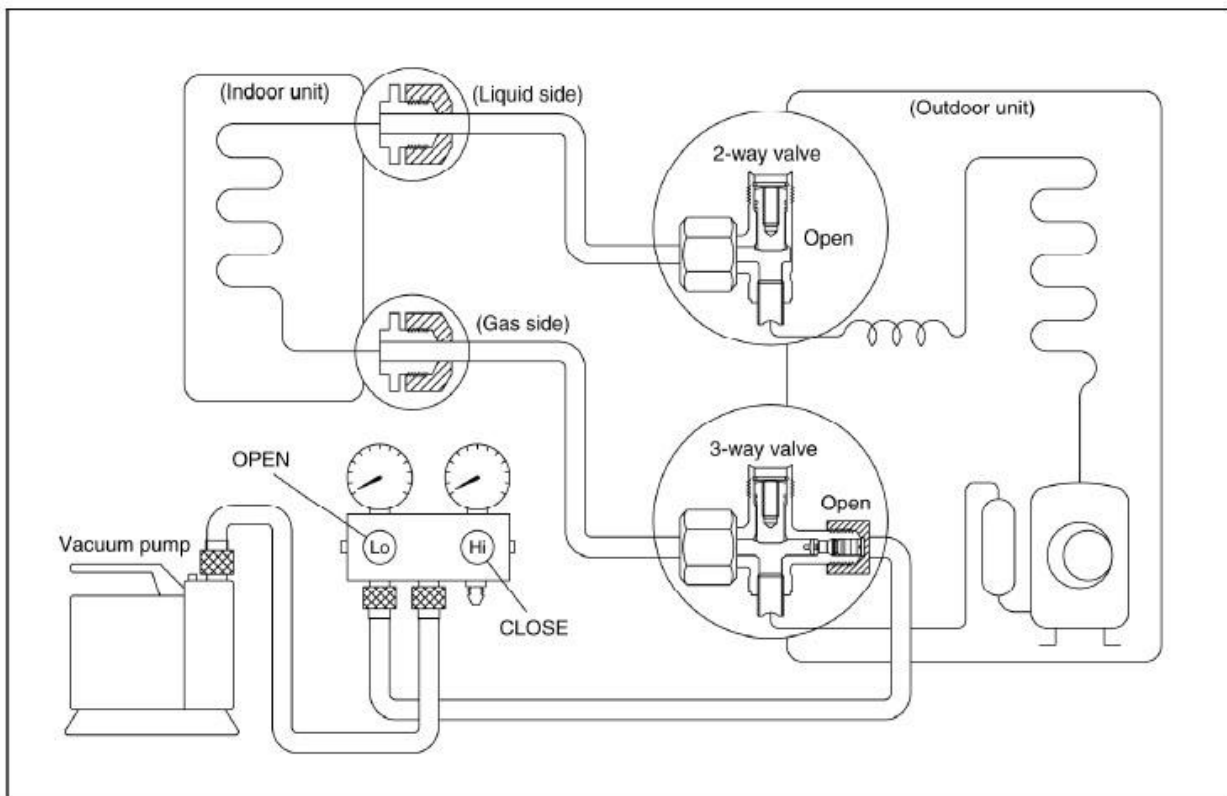

Procedure:

- 1). Confirm that both the 2-way and 3-way valves are set to the opened position.
- 2). Connect the vacuum pump to 3-way valve's service port.
- 3). Evacuation for approximately one hour. Confirm that the compound meter indicates -0.1Mpa.
- 4). Close the valve (Low side) on the charge set, turn off the vacuum pump, and confirm that the gauge needle does not move (approximately 5 minutes after turning off the vacuum pump).
- 5). Disconnect the charge hose from the vacuum pump.

2. Refrigerant charging

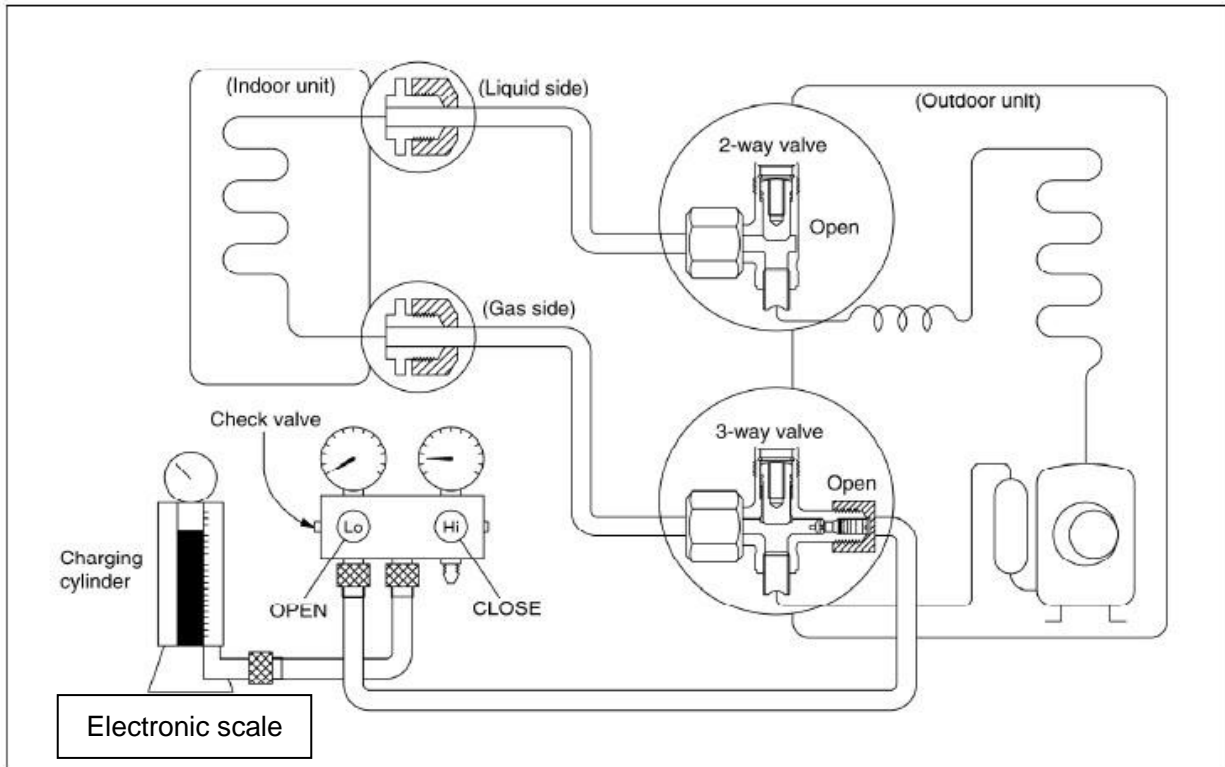

Procedure:

- 1). Connect the charge hose to the charging cylinder, open the 2-way valve and the 3-way valve
Connect the charge hose which you disconnected from the vacuum pump to the valve at the bottom of the cylinder. If the refrigerant is R410A, make the cylinder bottom up to ensure liquid charge.
- 2). Purge the air from the charge hose
Open the valve at the bottom of the cylinder and press the check valve on the charge set to purge the air (be careful of the liquid refrigerant).
- 3) Put the charging cylinder onto the electronic scale and record the weight.
- 4). Open the valves (Low side) on the charge set and charge the system with liquid refrigerant
If the system cannot be charge with the specified amount of refrigerant, or can be charged with a little at a time (approximately 150g each time) , operating the air conditioner in the cooling cycle; however, one time is not sufficient, wait approximately 1 minute and then repeat the procedure.
- 5).When the electronic scale displays the proper weight, disconnect the charge hose from the 3-way valve's service port immediately
If the system has been charged with liquid refrigerant while operating the air conditioner, turn off the air conditioner before disconnecting the hose.
- 6). Mounted the valve stem caps and the service port

Use torque wrench to tighten the service port cap to a torque of 18N.m.

Be sure to check for gas leakage

7. Operation characteristics

Temperature Mode	Cooling operation	Heating operation	Drying operation
Room temperature	$\geq 17^{\circ}\text{C}$	$\leq 30^{\circ}\text{C}$	$> 10^{\circ}\text{C}$
Outdoor temperature	$0^{\circ}\text{C} \sim 50^{\circ}\text{C}$	$-15^{\circ}\text{C} \sim 34^{\circ}\text{C}$	$0^{\circ}\text{C} \sim 50^{\circ}\text{C}$
	$-15^{\circ}\text{C} \sim 50^{\circ}\text{C}$ (For the models with low temperature cooling system)		

CAUTION:

1. If air conditioner is used beyond the above conditions, the certain protections may action.
2. Room relative humidity should be less than 80%. If the air conditioner operates in excess of this value, the surface of the air conditioner may attract condensation water. In this case, please set the vertical air louver to its maximum angle (vertically to the floor), and set the fan to high speed.

8. Electronic function

8.1 Abbreviation

T1: Indoor room temperature

T2: Coil temperature of evaporator

T3: Coil temperature of condenser

T4: Outdoor ambient temperature

T5: Compressor discharge temperature

8.2 Display function

8.2.1 Icon explanation on indoor display board.

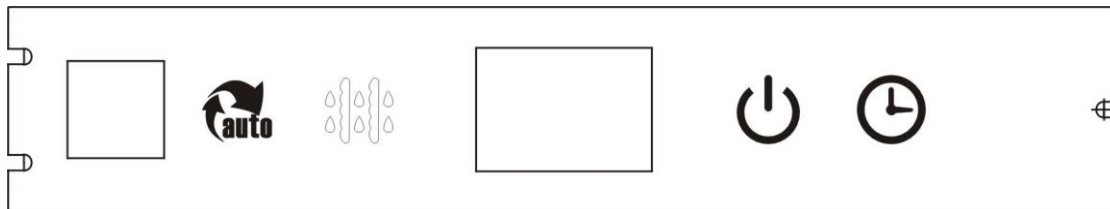

	Auto indicator: This indicator illuminates when the air conditioner is in AUTO operation.
	Timer indicator: This indicator illuminates when TIMER is set ON/OFF
	PRE.-DEF. Indicator: This indicator illuminates when the air conditioner starts defrosting automatically or when the warm air control feature is activated in heating mode.
	OPERATION indicator: This indicator illuminates when the air conditioner is running.

8.3 Main Protection

8.3.1 Three Minutes Delay at restart for compressor

1 minute delay for the 1st time start-up and 3 minutes delay for others.

8.3.2 Temperature protection of compressor top

The unit will stop working when the compressor top temp. protector cut off, and will restart after the compressor top temp. protector restart.

8.3.3 Temperature protection of compressor discharge

When the compressor discharge temp. is getting higher, the running frequency will be limited as below rules:

---Compressor discharge temp. $T_5 > 115^{\circ}\text{C}$ for 5s, compressor stops.

--- $108 < T_5 < 115^{\circ}\text{C}$, decrease the frequency to the lower level every 3 minutes.

--- $90 < T_5 < 105^{\circ}\text{C}$, keep running at the current frequency.

---- $T_5 < 90^{\circ}\text{C}$, no limit for frequency.

8.3.4 Fan Speed is out of control

When Indoor Fan Speed keeps too low (300RPM) for certain time, the unit will stop and the LED will display the failure

8.3.5 Inverter module Protection

The Inverter module has a protection function about current, voltage and temperature. If these protections happen, the corresponding code will display on indoor unit and the unit will stop working.

8.3.6 Indoor fan delayed open function

When the unit starts up, the louver will be active immediately and the indoor fan will open 10s later.

If the unit runs in heating mode, the indoor fan will be also controlled by anti-cold wind function.

8.3.7 Compressor preheating functions

Preheating permitting condition:

If T_4 (outdoor ambient temperature) $< 3^{\circ}\text{C}$ and the machine connects to power supply newly or if $T_4 < 3^{\circ}\text{C}$ and compressor has stopped for over 3 hours, the compressor heating cable will work.

Preheating mode:

A weak current flow through the coil of compressor from the wiring terminal of the compressor, then the compressor is heated without operation.

Preheating release condition:

If $T4 > 5^{\circ}\text{C}$ or the compressor starts running, the preheating function will stop.

8.3.8 Zero crossing detection error protection

If AC detects time interval is not correct for continuous 240s, the unit will stop and the LED will display the failure. The correct zero crossing signal time interval should be between 6-13ms.

8.4 Operation Modes and Functions

8.4.1 Fan mode

- (1) Outdoor fan and compressor stop.
- (2) Temperature setting function is disabled, and no setting temperature is displayed.
- (3) Indoor fan can be set to high/med/low/auto.
- (4) The louver operates same as in cooling mode.
- (5) Auto fan:

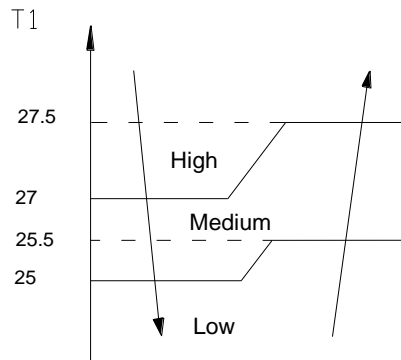

8.4.2 Cooling Mode

8.4.2.1 Compressor running rules

The maximum operation frequency of compressor after starting submits to following rule.

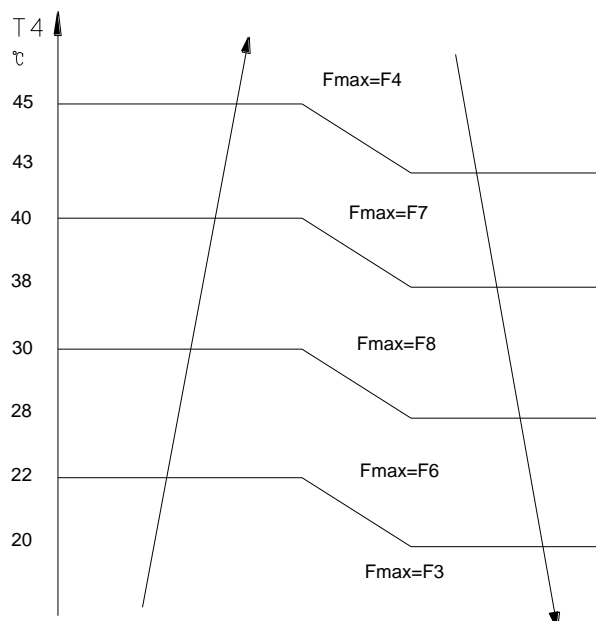

If users switch on AC by remote controller, the compressor will run at the Fmax frequency for 7 minutes according to the outdoor ambient temp. During the 7 minutes, the frequency limitation is active. 7 minutes later, the compressor running frequency will be controlled as below:

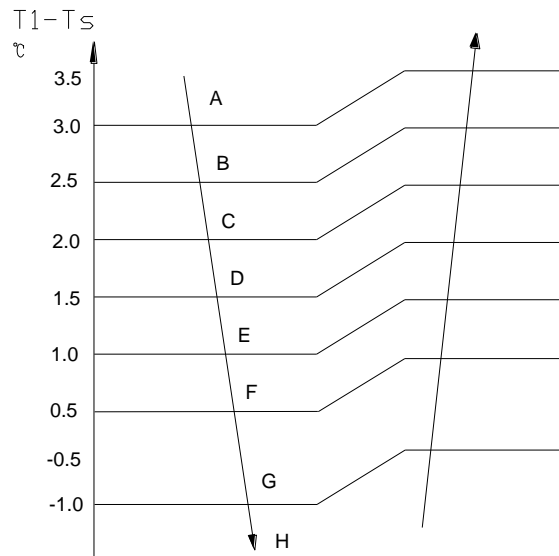

While

Temp. zone	A	B	C	D	E	F	G
Frequency	F8	F8	F7	F6	F5	F3	F1

Note:

When T1-Ts keeps in the same temp. zone for 3 minutes, the compressor will run as the below rules:

A~E: Increase the frequency to the higher level until to F8.

F: Keep the current frequency.

G: Decrease the frequency to the lower level until to F1.

H: Run at F1 for 1h.(if $T1-Ts < -2^{\circ}C$, the compressor will stop)

Meanwhile, the compressor running frequency is limited by the current.

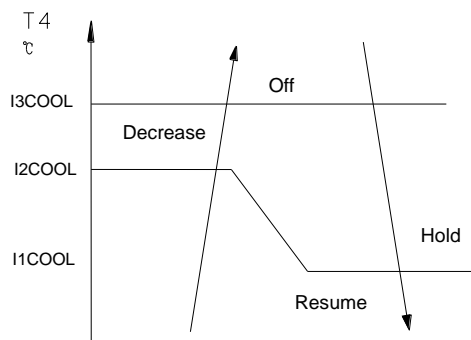

Off: Compressor stops.

Decrease: Decrease the running frequency to the lower level.

Hold: Keep the current frequency.

Resume: No limitation for frequency.

Note:

When AC is in “hold” zone for 3 minutes, the compressor frequency will rise to the higher level.(frequency will increase twice at most)

8.4.2.2 Outdoor fan running rules

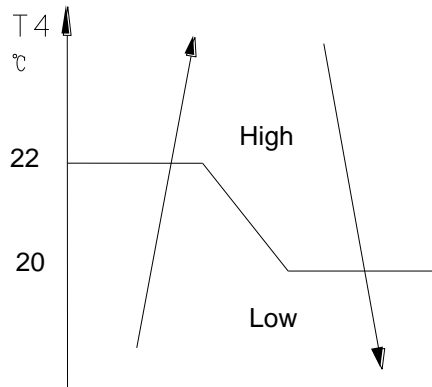

8.4.2.3 Indoor fan running rules

In cooling mode, indoor fan runs all the time and the speed can be selected as high, medium, low and auto.

Auto fan in cooling mode acts as follow:

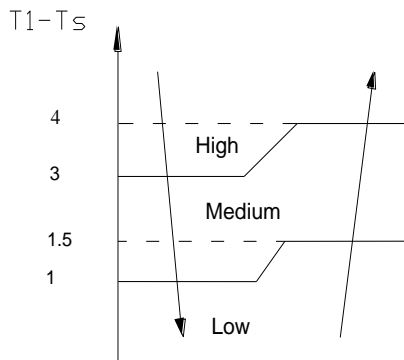

8.4.2.4 Condenser temperature protection

--- $55^{\circ}\text{C} < T_3 < 60^{\circ}\text{C}$, the compressor frequency will decrease to the lower level until to F1 and then runs at F1.If $T_3 < 54^{\circ}\text{C}$, the compressor will keep running at the current frequency.

--- $T_3 < 52^{\circ}\text{C}$, the compressor will not limit the frequency and resume to the former frequency.

--- $T_3 > 60^{\circ}\text{C}$ for 5 seconds, the compressor will stop until $T_3 < 52^{\circ}\text{C}$

8.4.2.5 Evaporator temperature protection

--- $T_2 < 0^{\circ}\text{C}$, the compressor will stop and restart when $T_2 \geq 5^{\circ}\text{C}$

--- $0^{\circ}\text{C} \leq T_2 < 4^{\circ}\text{C}$, the compressor frequency will be limited and decreased to the lower level

--- $4^{\circ}\text{C} \leq T_2 \leq 7^{\circ}\text{C}$, the compressor will keep the current frequency.

--- $T_2 > 7^{\circ}\text{C}$, the compressor frequency will not be limited.

8.4.3 Heating Mode

8.4.3.1 Compressor running rules

The maximum operation frequency of the compressor after starting submits to the following rule.

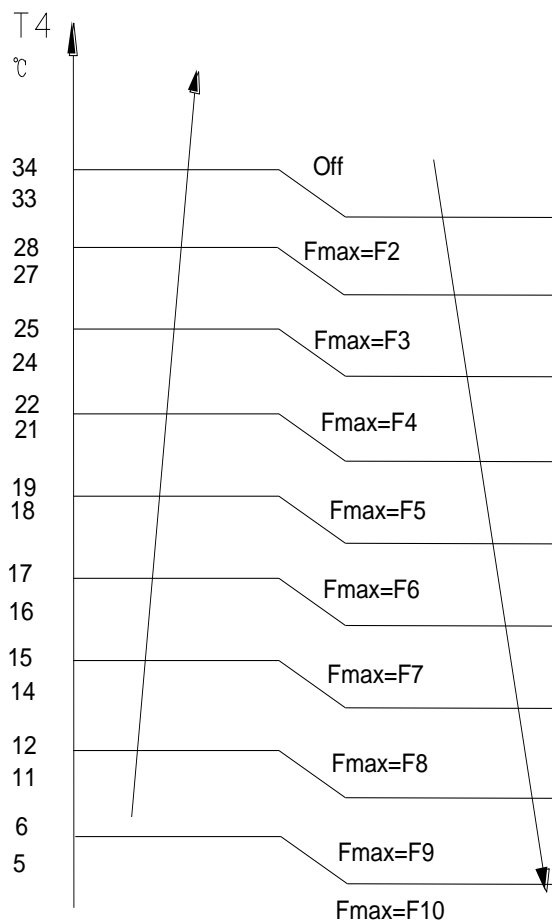

If users switch on AC by remote controller, the compressor will run at the F_{\max} frequency for 7 minutes according to outdoor ambient temp. During the 7 minutes, the frequency limitation is active.

7 minutes later, the compressor running frequency will be controlled as below:

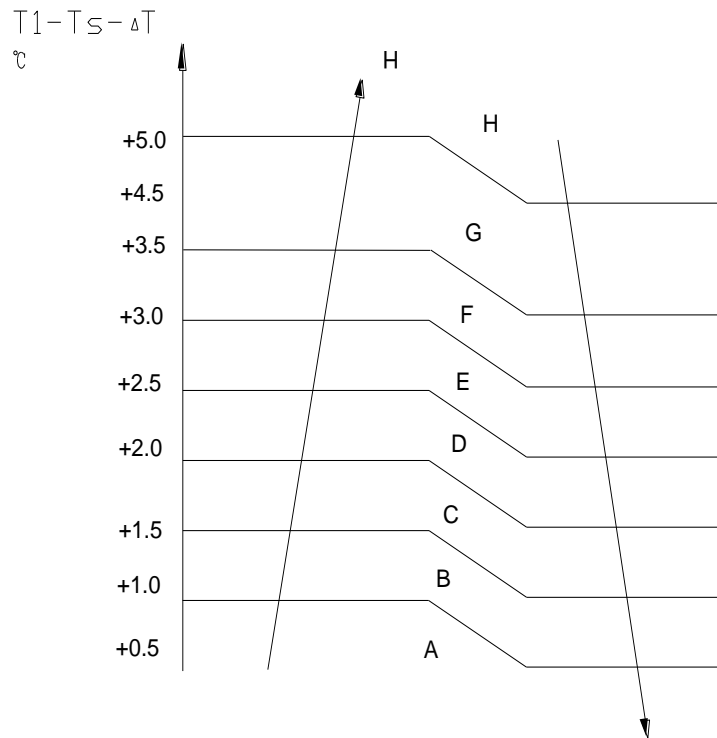

While

Temp. zone	A	B	C	D	E	F	G
Frequency	F10	F9	F8	F7	F5	F3	F1

$\Delta T = 0^\circ\text{C}$ as default.

Note:

When $T_1 - T_s$ keeps in the same temp. zone for 3 minutes, the compressor will run as the below rules:

A~E: Increase the frequency to the higher level until to F10.

F: Keep the current frequency.

G: Decrease the frequency to the lower level until to F1.

H: Run at F1 for 1h. (if $T_1 - T_s - \Delta T > 6^\circ\text{C}$, the compressor will stop)

Meanwhile, the compressor running frequency is limited by the current.

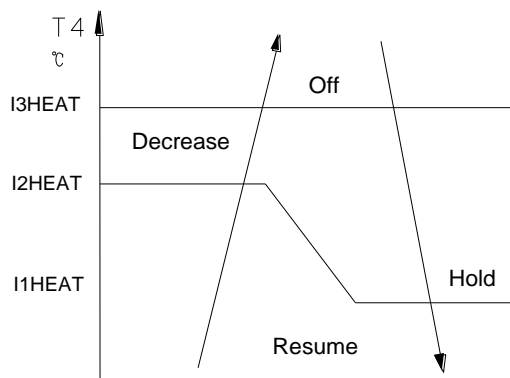

Off: Compressor stops.

Decrease: Decrease the running frequency to the lower level.

Hold: Keep the current frequency.

Resume: No limitation for frequency.

Note:

When AC is in “hold” zone for 3 minutes, the compressor frequency will rise to the higher level. (The frequency will increase twice at most)

8.4.3.2 Outdoor fan running rules

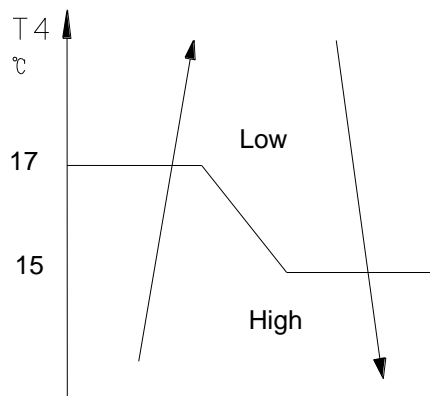

8.4.3.3 Indoor fan running rules

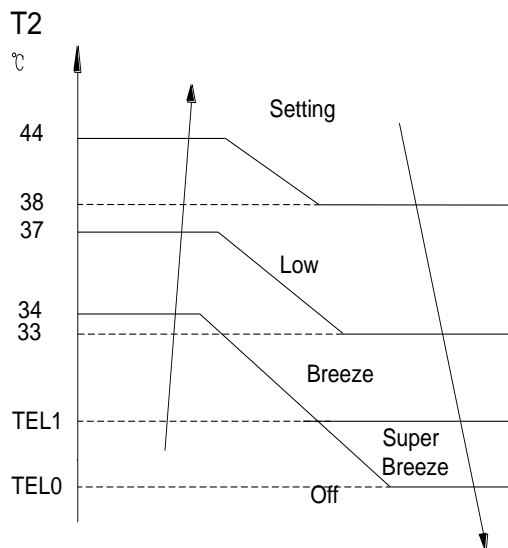

TEL1=24, TEL0=17.

If the compressor stops caused by the room temperature rising, the indoor fan will be forced to run 127 seconds with breeze. During this period, the anti-cold-wind is disabled.

If the machine runs in rating capacity test mode, the indoor fan will run with rating speed and the anti-cold-wind function is disabled.

Indoor fan speed can be set as high, medium, low or auto fan and the anti-cold-wind function is preferential.

Auto fan action in heating mode:

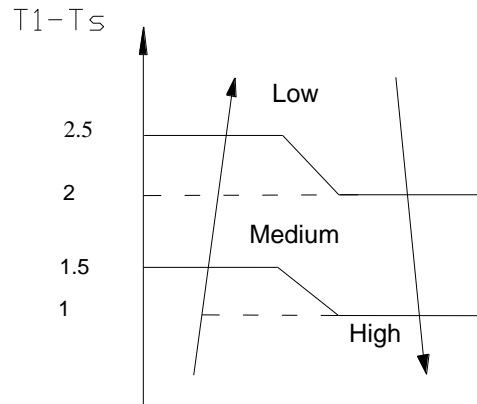

8.4.3.4 Defrosting mode

Condition of defrosting:

--- $T_4 > 0^\circ\text{C}$,

When the units are running, if the following two items are satisfied, the units start defrosting:

The units run with $T_3 < 3^\circ\text{C}$ for 40 minutes and T_3 keeps lower than $\text{TCDI}^\circ\text{C}$ for more than 3 minutes.

The units run with $T_3 < 3^\circ\text{C}$ for 80 minutes and T_3 keeps lower than $\text{TCDI} + 2^\circ\text{C}$ for more than 3 minutes.

While $\text{TCDI} = -6^\circ\text{C}$.

--- $T_4 < 0^\circ\text{C}$,

If the 1st condition and 2nd condition items are satisfied, then the program judges if T_2 has decreased more than 5°C . When T_2 has decreased more than 5°C , enter the defrosting mode.

---No matter what value T_4 is, if the machine runs with $T_3 < 3^\circ\text{C}$ for more than 120 minutes and T_3 keeps lower than $\text{TCDI} + 4^\circ\text{C}$ for more than 3 minutes, the machine will enter defrosting mode no matter if T_2 drops more than 5°C or not.

Condition of ending defrosting:

If any one of the following items is satisfied, the defrosting will finish and the machine will turn to normal heating mode.

--- T_3 rises to be higher than $\text{TCDE}1^\circ\text{C}$.

--- T_3 keeps to be higher than $\text{TCDE}2^\circ\text{C}$ for 80 seconds.

---The machine has run for 10 minutes in defrosting mode.

While $\text{TCDE}1 = 12^\circ\text{C}$, $\text{TCDE}2 = 8^\circ\text{C}$ for 9k models. $\text{TCDE}1 = 14^\circ\text{C}$, $\text{TCDE}2 = 8^\circ\text{C}$ for 12k models.

TCDE1=15°C, TCDE2=8°C for 18k model.

Defrosting action:

For 9k,12k models:

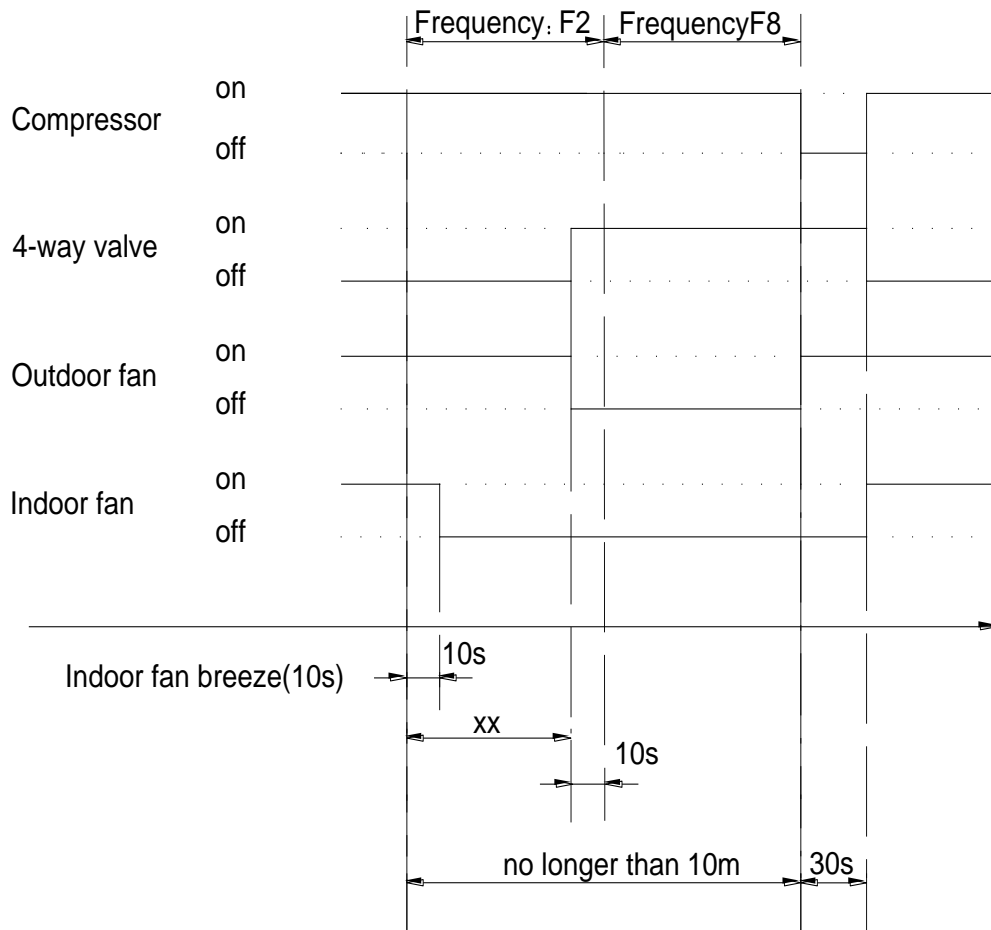

While $xx=60$.

For 18k model:

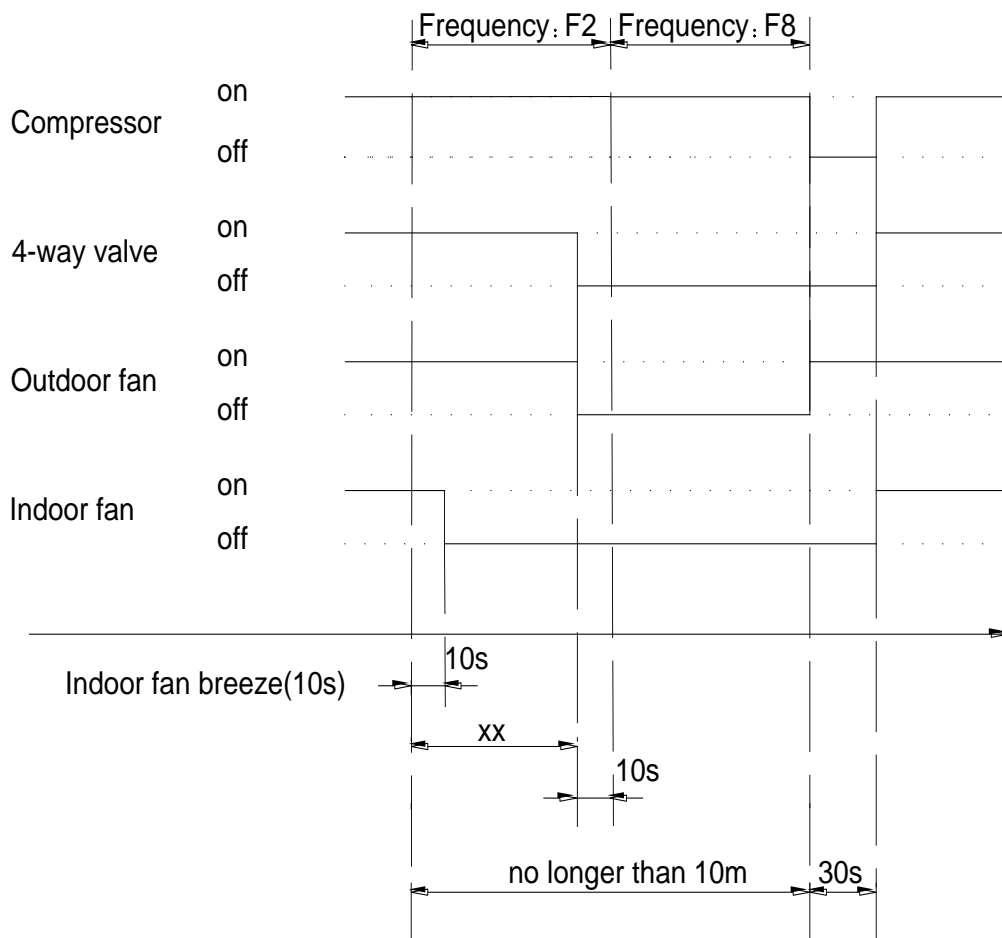

While $xx=60s$ for 18k.

8.4.3.5 Evaporator coil temperature protection

--- $T_2 > TEH_2^{\circ}C$, the compressor running frequency decreases to the lower level and runs for 20s.

When the frequency decreases to F_2 and the T_2 is still over $TEH_2^{\circ}C$ for 3 minutes, the compressor will stop.

--- $T_2 < 48^{\circ}C$ or T_2 stays in $48^{\circ}C \sim TEH_2^{\circ}C$ for 6 minutes, the frequency will not be limited by T_2 .

--- $T_2 > 60^{\circ}C$, the compressor will stop and restart when $T_2 < 48^{\circ}C$.

While $TEH_2=53^{\circ}C$

8.4.4 Auto-mode

This mode can be chosen with remote controller and the setting temperature can be changed between $17 \sim 30^{\circ}C$.

In auto mode, the machine will choose cooling, heating or fan-only mode according to ΔT ($\Delta T = T_1 - T_s$).

$\Delta T = T_1 - T_s$	Running mode
$\Delta T > 1^\circ\text{C}$	Cooling
$-1 < \Delta T \leq 1^\circ\text{C}$	Fan-only
$\Delta T \leq -1^\circ\text{C}$	Heating

Indoor fan will run at auto fan of the relevant mode.

The louver operates same as in relevant mode.

If the machine switches mode between heating and cooling, the compressor will keep stopping for 15 minutes and then choose mode according to $T_1 - T_s$.

If the setting temperature is modified, the machine will choose running function again.

8.4.5 Drying mode

8.4.5.1 Indoor fan speed is fixed at breeze and can't be changed. The louver angle is the same as in cooling mode.

8.4.5.2 Compressor running rules

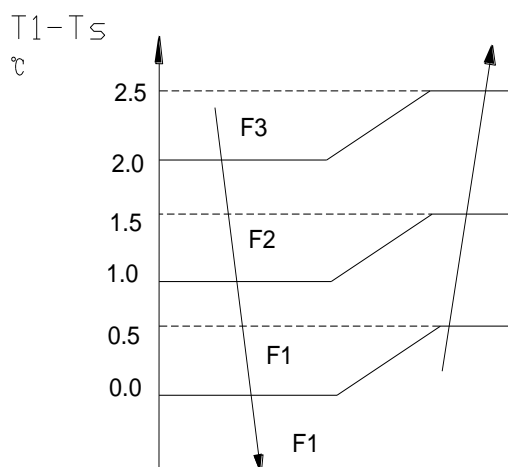

8.4.5.3 Low indoor room temperature protection

In drying mode, if room temperature is lower than 10°C , the compressor will stop and not resume until room temperature exceeds 12°C .

8.4.5.4 Evaporator anti-freezing protection, condenser high temperature protection and outdoor unit frequency limit are active and the same as that in cooling mode.

8.4.5.5 The outdoor fan operates the same as in cooling mode.

8.4.6 Forced operation function

8.4.6.1 Enter forced operation function:

When the machine is off, pressing the touch button will carry the machine to forced auto mode. If

pressing the button once again within 5 seconds, the machine will turn into forced cooling mode.

In forced auto, forced cooling or any other operation mode, pressing touch button will turn off the machine.

8.4.6.2 In forced operation mode, all general protections and remote control are available.

8.4.6.3 Operation rules:

Forced cooling mode:

The compressor runs at F2 frequency and indoor fan runs as breeze. After running for 30 minutes. the machine will turn to auto mode as 24°C setting temperature.

Forced auto mode:

The action of forced auto mode is the same as normal auto mode with 24°C setting temperature.

8.4.7 Timer function

8.4.7.1 Timing range is 24 hours.

8.4.7.2 Timer on. The machine will turn on automatically when reaching the setting time.

8.4.7.3 Timer off. The machine will turn off automatically when reaching the setting time.

8.4.7.4 Timer on/off. The machine will turn on automatically when reaching the setting “on” time, and then turn off automatically when reaching the setting “off” time.

8.4.7.5 Timer off/on. The machine will turn off automatically when reaching the setting “off” time, and then turn on automatically when reaching the setting “on” time.

8.4.7.6 The timer function will not change the AC current operation mode. Suppose AC is off now, it will not start up firstly after setting the “timer off” function. And when reaching the setting time, the timer LED will be off and the AC running mode has not been changed.

8.4.7.7 The setting time is relative time.

8.4.8 Sleep function mode

8.4.8.1 Operation time in sleep mode is 7 hours. After 7 hours the AC quits this mode and turns off.

8.4.8.2. Operation process in sleep mode is as follow:

When cooling, the setting temperature rises 1°C (be lower than 30°C) every one hour, 2 hours later the setting temperature stops rising and indoor fan is fixed as low speed.

When heating, the setting temperature decreases 1°C (be higher than 17°C) every one hour, 2 hours later the setting temperature stops rising and indoor fan is fixed as low speed. (Anti-cold wind function has the priority)

8.4.8.3 Timer setting is available

8.4.8.4 When user uses timer off function in sleep mode (or sleep function in timer off mode), if the timing is less than 7 hours, sleep function will be cancelled when reaching the setting time. If the timing is more than 7 hours, the machine will not stop until reaches the setting time in sleep mode.

8.4.9 Auto-Restart function

The indoor unit is equipped with auto-restart function, which is carried out through an auto-restart module. In case of a sudden power failure, the module memorizes the setting conditions before the power failure. The unit will resume the previous operation setting (not including swing function) automatically after 3 minutes when power returns.

If the memorization condition is forced cooling mode, the unit will run in cooling mode for 30 minutes and turn to auto mode as 24°C setting temp.

If AC is off before power off and AC is required to start up now, the compressor will have 1 minute delay when power on. Other conditions, the compressor will have 3 minutes delay when restarts.

8.4.10 8°C Heating(optional)

In heating operation, the preset temperature of the air conditioner can be as lower as 8°C, which keeps the room temperature steady at 8°C and prevents household things freezing when the house is unoccupied for a long time in severe cold weather.

9. Troubleshooting

9.1 Indoor Unit Error Display

Display	LED STATUS
E0	EEPROM parameter error
E1	Indoor unit and outdoor unit communication protection
E2	Zero-crossing signal error
E3	Indoor fan speed has been out of control
E5	Open or short circuit of outdoor temperature sensor or outdoor unit EEPROM parameter error
E6	Open or short circuit of room temperature sensor
P0	IPM malfunction
P1	Over voltage or too low voltage protection
P2	Temperature protection of compressor top(only for MSR1-18HRDN1-QC2(E))
P4	Inverter compressor drive error

Note: E4 & P3: Reserved function.

9.2 Diagnosis and Solution

9.2.1 EEPROM parameter error diagnosis and solution

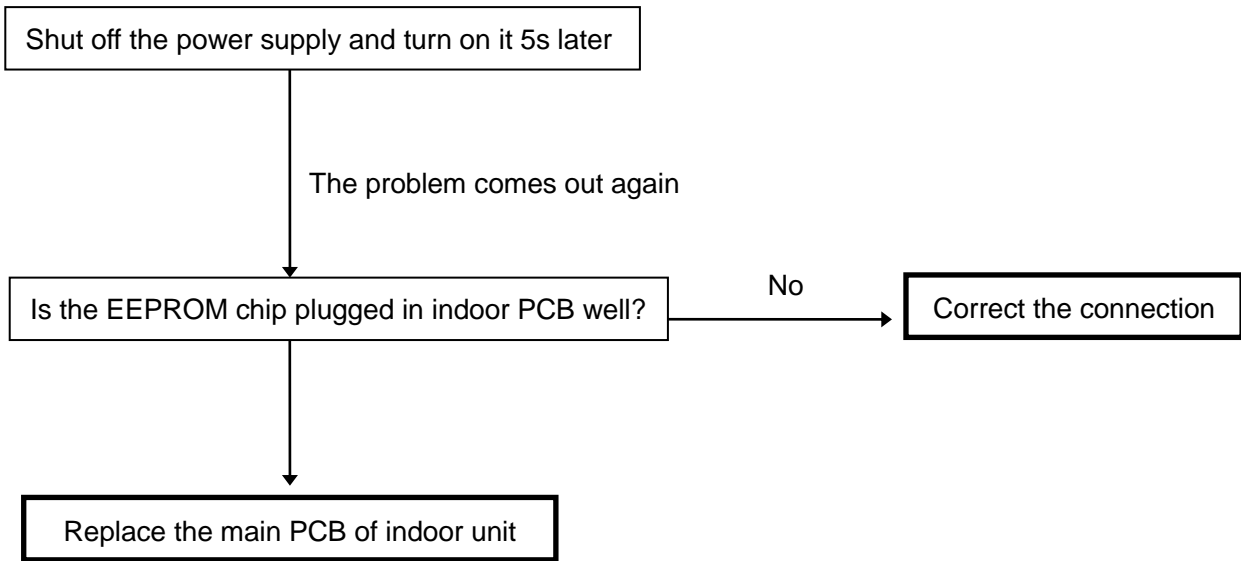

9.2.2 Indoor / outdoor unit's communication error diagnosis and solution

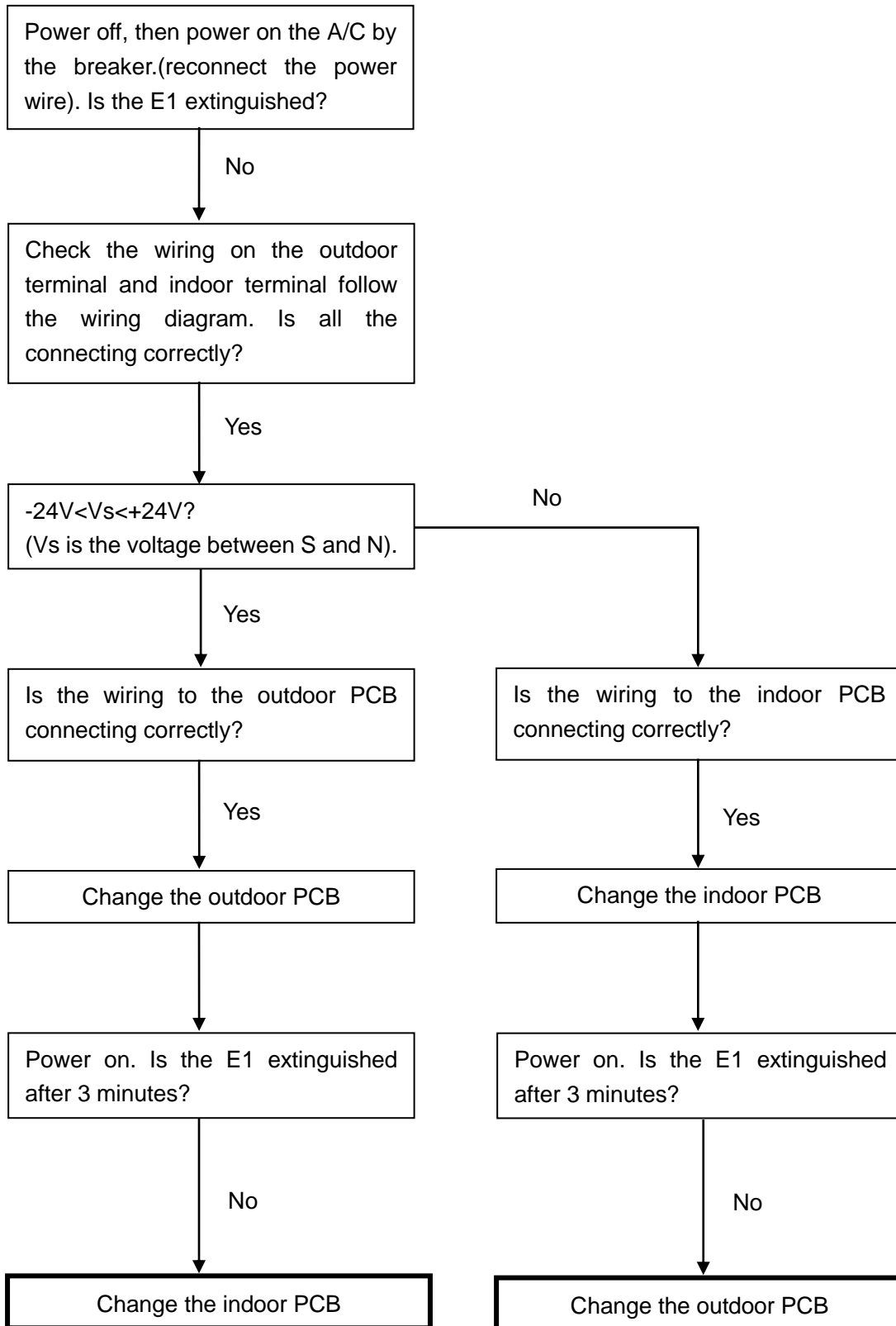

9.2.3 Indoor fan speed has been out of control diagnosis and solution

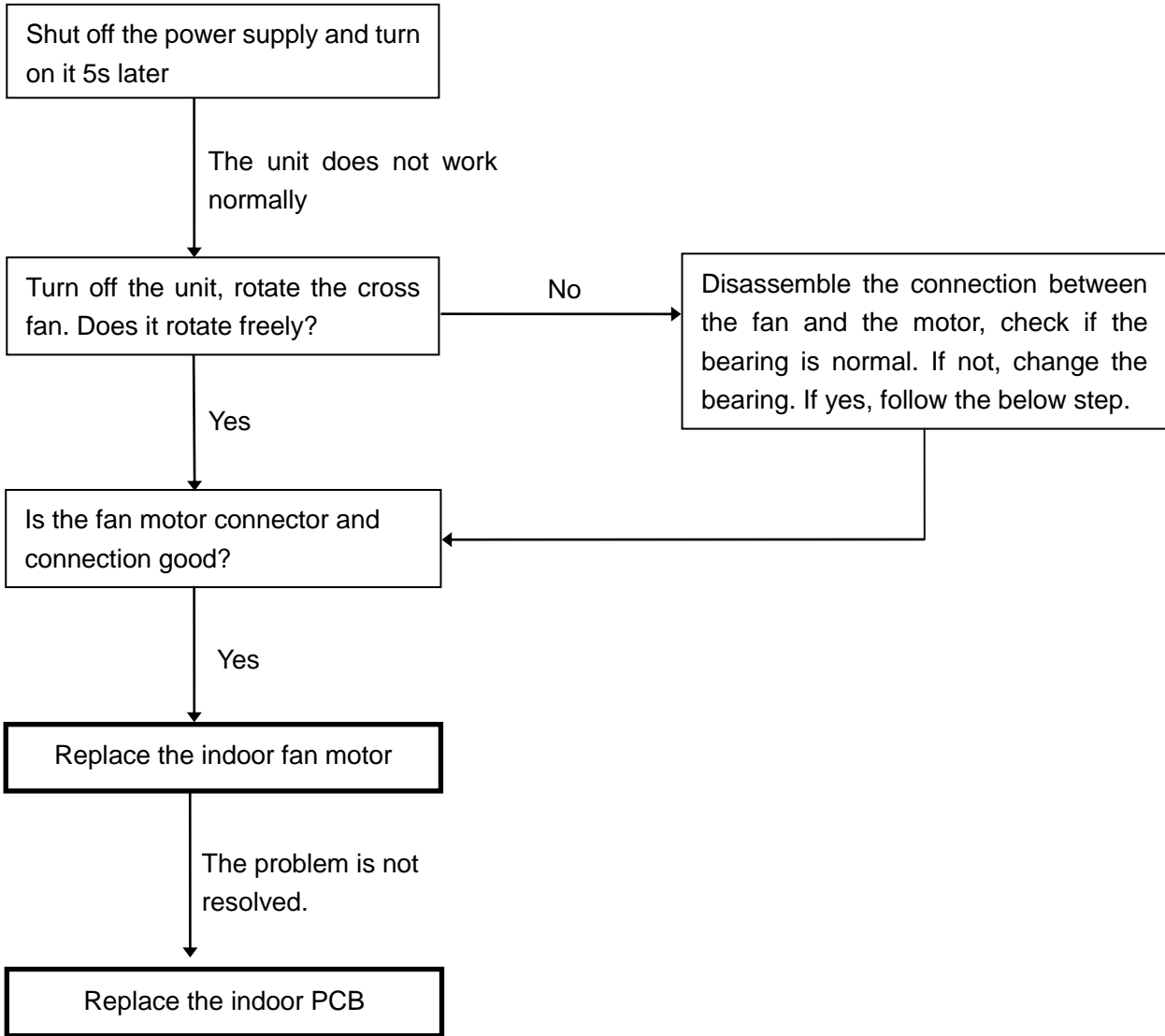

9.2.4 Open or short circuit of temperature sensor diagnosis and solution

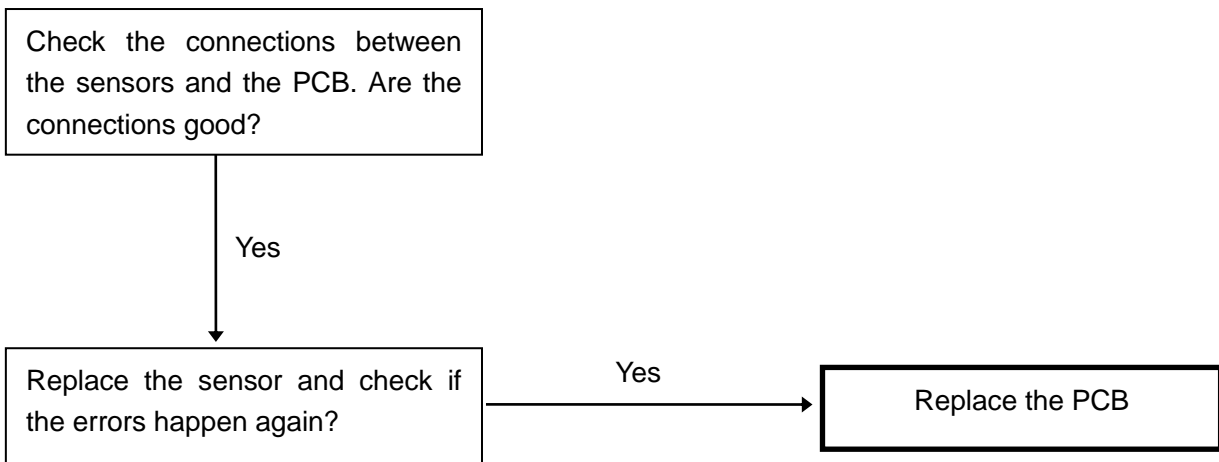

9.2.5 IPM malfunction diagnosis and solution

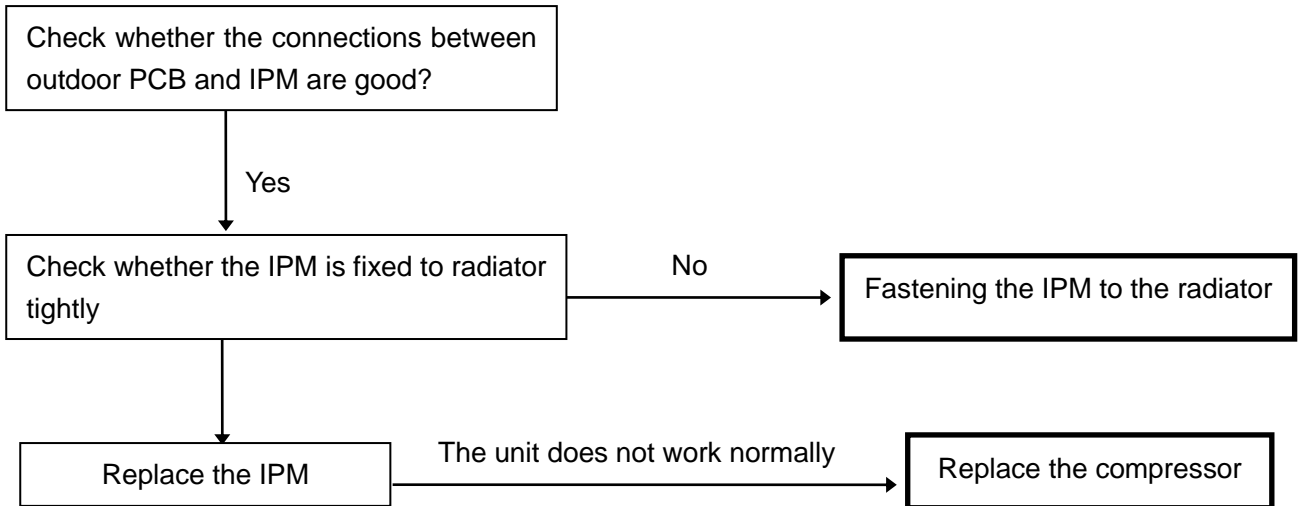

9.2.6 Over voltage or too low voltage protection diagnosis and solution

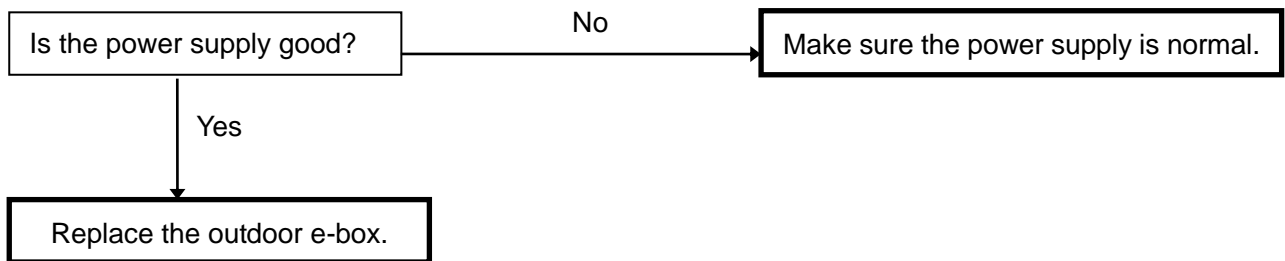

9.2.7 High temperature protection of compressor top diagnosis and solution

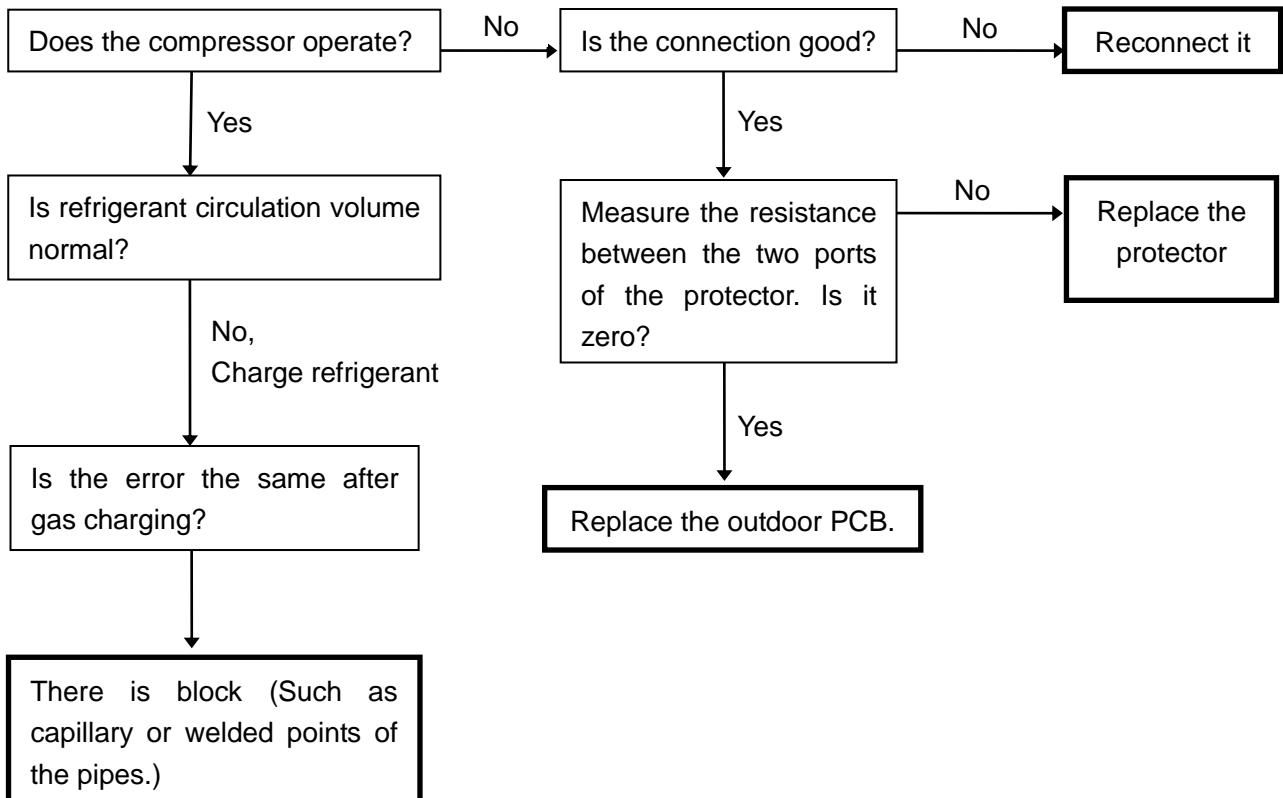

9.2.8 Inverter compressor drive error diagnosis and solution

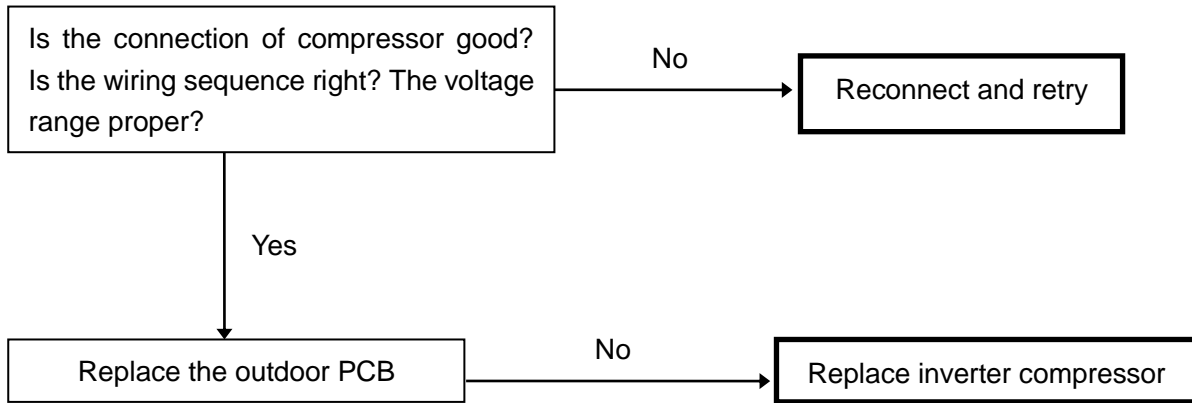

9.2.9 Zero crossing detection error diagnosis and solution

This is alarm signal when the main chip can't detect over-zero signal. When such failure occurs, the main control board must have fault.