

# SERVICE MANUAL

MDV AIRCONDITIONER  
EUROPE MARKET  
SPLIT WALL-MOUNTED TYPE

1A INVERTER SERIES

# CONTENTS

<b>1. Precaution</b> .....	<b>1</b>
1.1 Safety Precaution.....	1
1.2 Warning .....	1
<b>2. Function</b> .....	<b>6</b>
<b>3. Dimension</b> .....	<b>9</b>
3.1 Indoor Unit.....	9
3.2 Outdoor Unit.....	10
<b>4. Refrigerant Cycle Diagram</b> .....	<b>11</b>
<b>5. Wiring Diagram</b> .....	<b>12</b>
5.1 Indoor Unit.....	12
5.2 Outdoor Unit.....	14
<b>6. Installation details</b> .....	<b>17</b>
6.1 Wrench torque sheet for installation .....	17
6.2 Connecting the cables .....	17
6.3 Pipe length and the elevation .....	18
6.4 Air purging with vacuum pump.....	20
6.5 Pumping down (Re-installation).....	21
6.6 Re-air purging (Re-installation).....	22
6.7 Balance refrigerant of the 2-way, 3-way valves .....	23
6.8 Evacuation .....	24
6.9 Gas charging.....	25
<b>7. Operation characteristics</b> .....	<b>26</b>
<b>8. Electronic function</b> .....	<b>27</b>
8.1 Abbreviation .....	27
8.2 Display function.....	27
8.3 Main Protection .....	28
8.4 Operation Modes and Functions.....	29
<b>9. Troubleshooting</b> .....	<b>40</b>
9.1 Indoor Unit Error Display.....	40
9.2 Diagnosis and Solution .....	41

# 1. Precaution

## 1.1 Safety Precaution

- To prevent injury to the user or other people and property damage, the following instructions must be followed.

- Incorrect operation due to ignoring instruction will cause harm or damage.
- Before service unit, be sure to read this service manual at first.

## 1.2 Warning

### ➤ Installation

- Do not use a defective or underrated circuit breaker. Use this appliance on a dedicated circuit.

There is risk of fire or electric shock.

- For electrical work, contact the dealer, seller, a qualified electrician, or an authorized service center.

Do not disassemble or repair the product, there is risk of fire or electric shock.

- Always ground the product.

There is risk of fire or electric shock.

- Install the panel and the cover of control box securely.

There is risk of fire of electric shock.

- Always install a dedicated circuit and breaker.

Improper wiring or installation may cause fire or electric shock.

- Use the correctly rated breaker or fuse.

There is risk of fire or electric shock.

- Do not modify or extend the power cable.

There is risk of fire or electric shock.

- Do not install, remove, or reinstall the unit by yourself(customer).

There is risk of fire, electric shock, explosion, or injury.

- Be caution when unpacking and installing the product.

Sharp edges could cause injury, be especially careful of the case edges and the fins on the condenser and evaporator.

- **For installation, always contact the dealer or an Authorized service center.**

There is risk of fire, electric shock, explosion, or injury.

- **Do not install the product on a defective installation stand.**

It may cause injury, accident, or damage to the product.

- **Be sure the installation area does not deteriorate with age.**

If the base collapses, the air conditioner could fall with it, causing property damage, product failure, and personal injury.

- **Do not let the air conditioner run for a long time when the humidity is very high and a door or a window is left open.**

Moisture may condense and wet or damage furniture.

- **Take care to ensure that power cable could not be pulled out or damaged during operation.**

There is risk of fire or electric shock.

- **Do not place anything on the power cable.**

There is risk of fire or electric shock.

- **Do not plug or unplug the power supply plug during operation.**

There is risk of fire or electric shock.

- **Do not touch (operation) the product with wet hands.**

There is risk of fire or electric shock.

- **Do not place a heater or other appliance near the power cable.**

There is risk of fire and electric shock.

- **Do not allow water to run into electric parts.**

It may cause fire, failure of the product, or electric shock.

- **Do not store or use flammable gas or combustible near the product.**

There is risk of fire or failure of product.

- **Do not use the product in a tightly closed space for a long time.**

Oxygen deficiency could occur.

- **When flammable gas leaks, turn off the gas and open a window for ventilation before turn the product on.**

Do not use the telephone or turn switches on or off.

There is risk of explosion or fire.

- **If strange sounds, or small or smoke comes from product. Turn the breaker off or disconnect the power supply cable.**

There is risk of electric shock or fire.

- **Stop operation and close the window in storm or hurricane. If possible, remove the product from the window before the hurricane arrives.**

There is risk of property damage, failure of product, or electric shock.

- **Do not open the inlet grill of the product during operation. (Do not touch the electrostatic filter, if the unit is so equipped.)**

There is risk of physical injury, electric shock, or product failure.

- **When the product is soaked (flooded or submerged), contact an Authorized service center.**

There is risk of fire or electric shock.

- **Be caution that water could not enter the product.**

There is risk of fire, electric shock, or product damage.

- **Ventilate the product from time to time when operating it together with a stove, etc.**

There is risk of fire or electric shock.

- **Turn the main power off when cleaning or maintaining the product.**

There is risk of electric shock.

- **When the product is not be used for a long time, disconnect the power supply plug or turn off the breaker.**

There is risk of product damage or failure, or unintended operation.

- **Take care to ensure that nobody could step on or fall onto the outdoor unit.**

This could result in personal injury and product damage.

### ➤ **CAUTION**

- **Always check for gas (refrigerant) leakage after installation or repair of product.**

Low refrigerant levels may cause failure of product.

- **Install the drain hose to ensure that water is drained away properly.**

A bad connection may cause water leakage.

- **Keep level even when installing the product.**

It can avoid vibration of water leakage.

- **Do not install the product where the noise or hot air from the outdoor unit could damage**

## **the neighborhoods.**

It may cause a problem for your neighbors.

- **Use two or more people to lift and transport the product.**

Avoid personal injury.

- **Do not install the product where it will be exposed to sea wind (salt spray) directly.**

It may cause corrosion on the product. Corrosion, particularly on the condenser and evaporator fins, could cause product malfunction or inefficient operation.

## ➤ **Operational**

- **Do not expose the skin directly to cool air for long periods of time. (Do not sit in the draft).**

This could harm to your health.

- **Do not use the product for special purposes, such as preserving foods, works of art, etc.**

## **It is a consumer air conditioner, not a precision refrigerant system.**

There is risk of damage or loss of property.

- **Do not block the inlet or outlet of air flow.**

It may cause product failure.

- **Use a soft cloth to clean. Do not use harsh detergents, solvents, etc.**

There is risk of fire, electric shock, or damage to the plastic parts of the product.

- **Do not touch the metal parts of the product when removing the air filter. They are very sharp.**

There is risk of personal injury.

- **Do not step on or put anything on the product. (outdoor units)**

There is risk of personal injury and failure of product.

- **Always insert the filter securely. Clean the filter every two weeks or more often if necessary.**

A dirty filter reduces the efficiency of the air conditioner and could cause product malfunction or damage.

- **Do not insert hands or other object through air inlet or outlet while the product is operated.**

There are sharp and moving parts that could cause personal injury.

- **Do not drink the water drained from the product.**

It is not sanitary could cause serious health issues.

- **Use a firm stool or ladder when cleaning or maintaining the product.**

Be careful and avoid personal injury.

- **Replace the all batteries in the remote control with new ones of the same type. Do not mix old and new batteries or different types of batteries.**

There is risk of fire or explosion.

- **Do not recharge or disassemble the batteries. Do not dispose of batteries in a fire.**

They may burn or explode.

- **If the liquid from the batteries gets onto your skin or clothes, wash it well with clean water. Do not use the remote if the batteries have leaked.**

The chemical in batteries could cause burns or other health hazards

The designs, and information in this book are subject to change without notice for product improvement.

## 2. Function

### Model Names of Indoor/Outdoor Units

	Capacity	Indoor units	Outdoor units
3D Inverter	9k	MS1Ai-09HRFN1	MOC3i-09HFN1
	12k	MS1Ai-12HRFN1	MOC3i-12HFN1



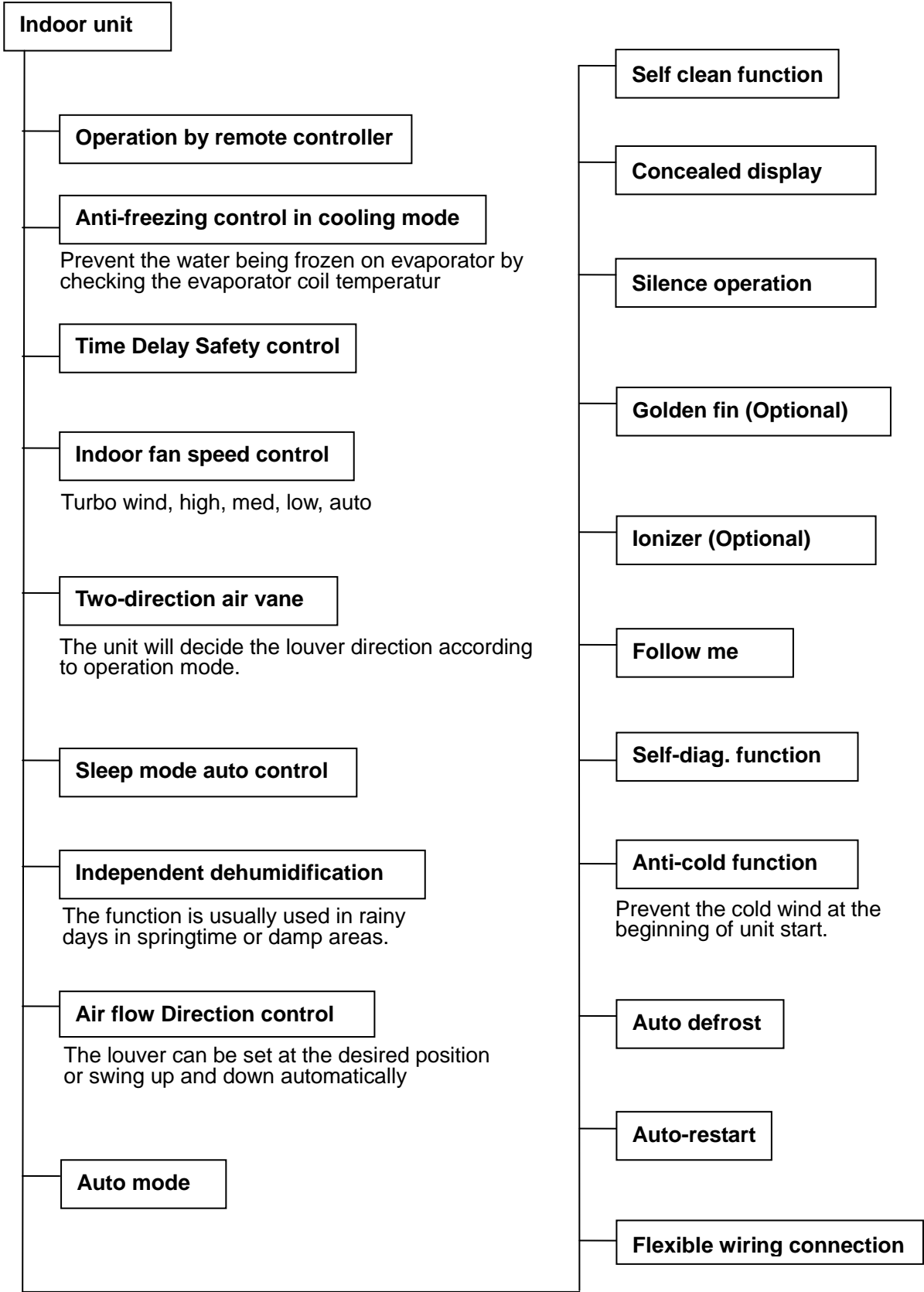

**Outdoor unit**

**Power relay control**

**Low noise air flow system**

**Hydrophilic aluminum fin**

The hydrophilic fin can improve the heating efficiency at operation mode.

**4 way valve control**

It is only operated in the heating operation mode except defrosting operation.

**Anti-rust cabinet**

Made from electrolytic zinc steel sheet and anti-rust coated components.

**Valve protection cover**

**Compressor crank case heater**

**Driving heating at -20°C for outdoor units**

### 3. Dimension

#### 3.1 Indoor Unit



For MS1Ai-09HRFN1, MS1Ai-12HRFN1 units,

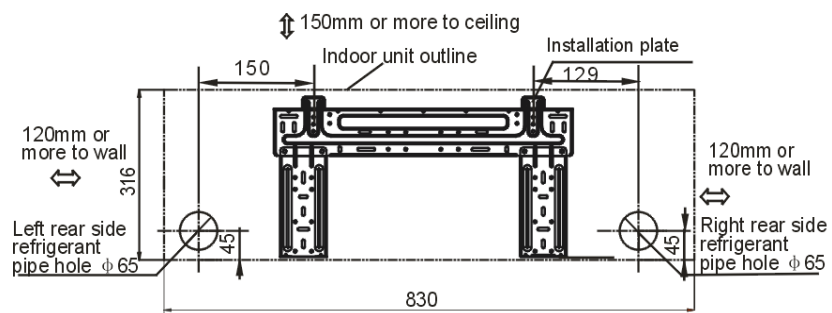

Model	Dimension (mm)		
	W	H	D
MS1Ai-09HRFN1	830	316	250
MS1Ai-12HRFN1	830	316	250

### 3.2 Outdoor Unit

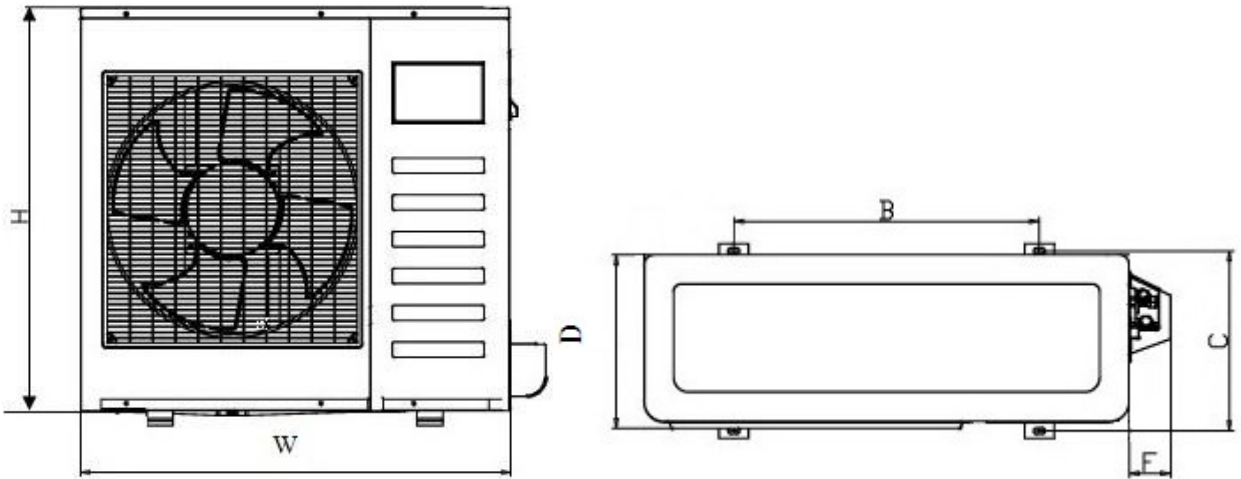
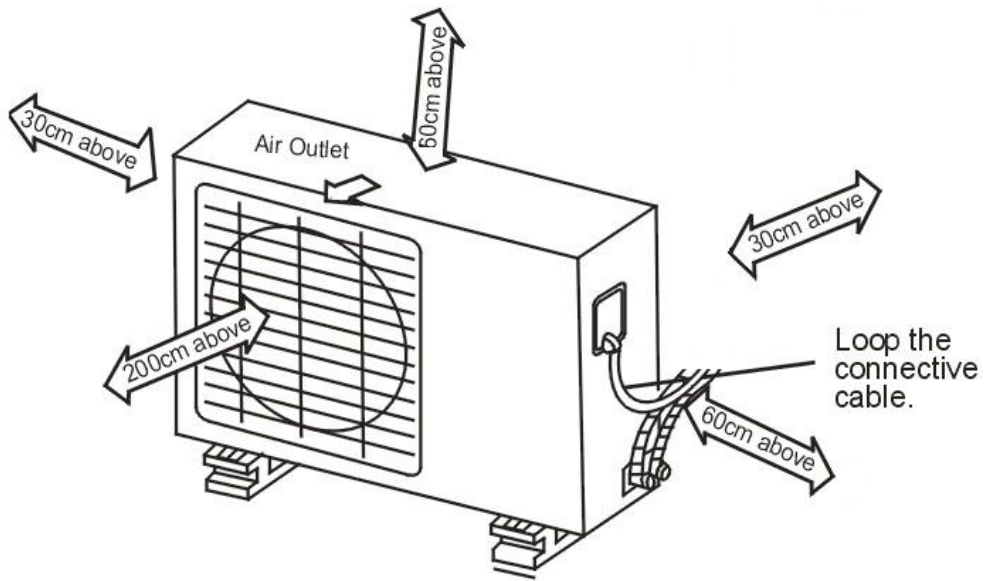

Model	W	H	D	B	C	F
MOC3i-09HFN1						
MOC3i-12HFN1	760	590	285	530	290	63

## 4. Refrigerant Cycle Diagram

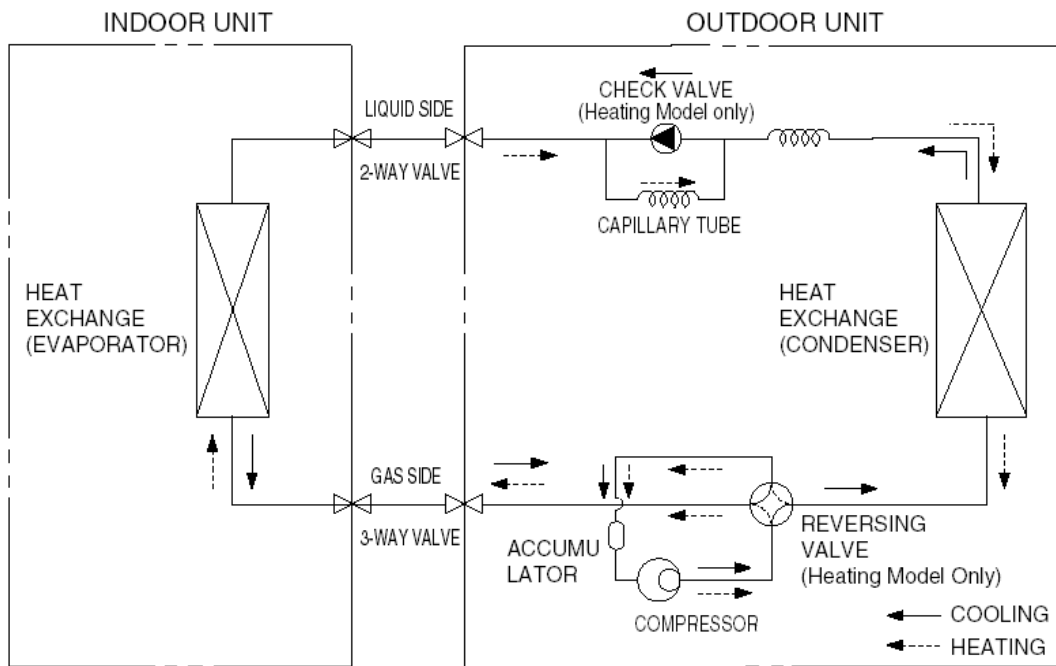

# 5. Wiring Diagram

## 5.1 Indoor Unit

MS1Ai-09HRFN1

MS1Ai-12HRFN1

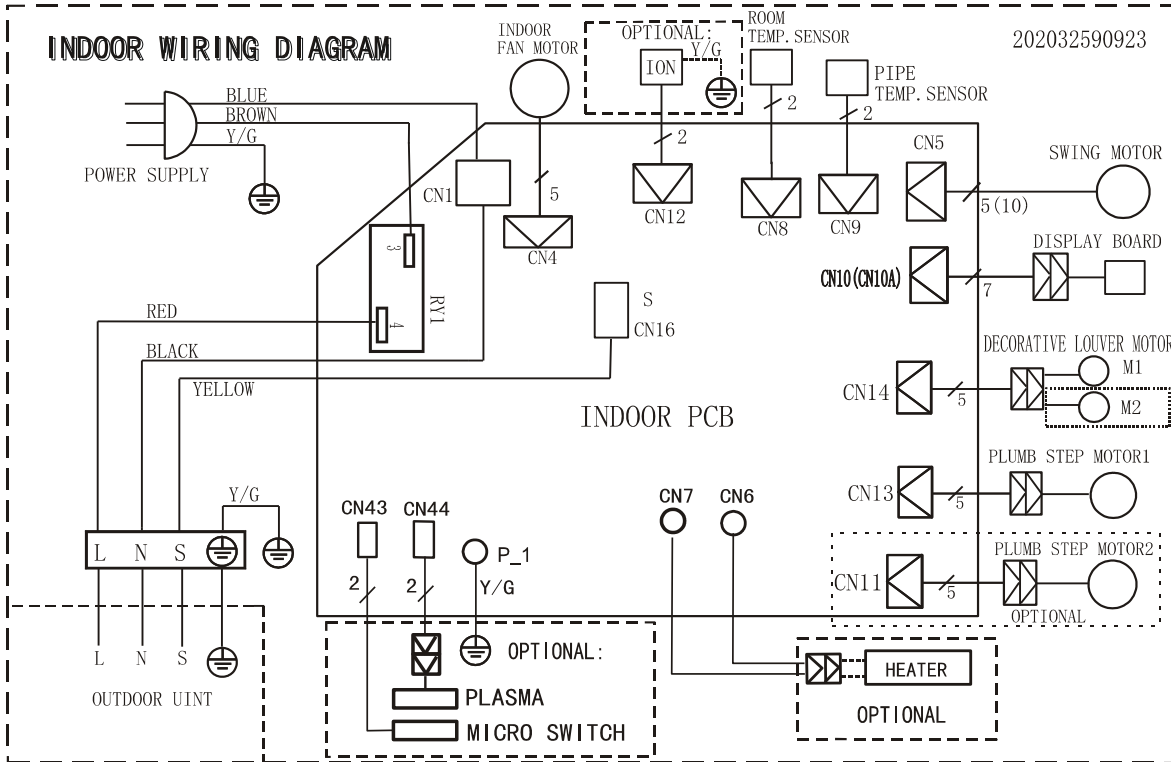

## 5.2 Outdoor Unit

MOC3i-09HFN1

MOC3i-12HFN1

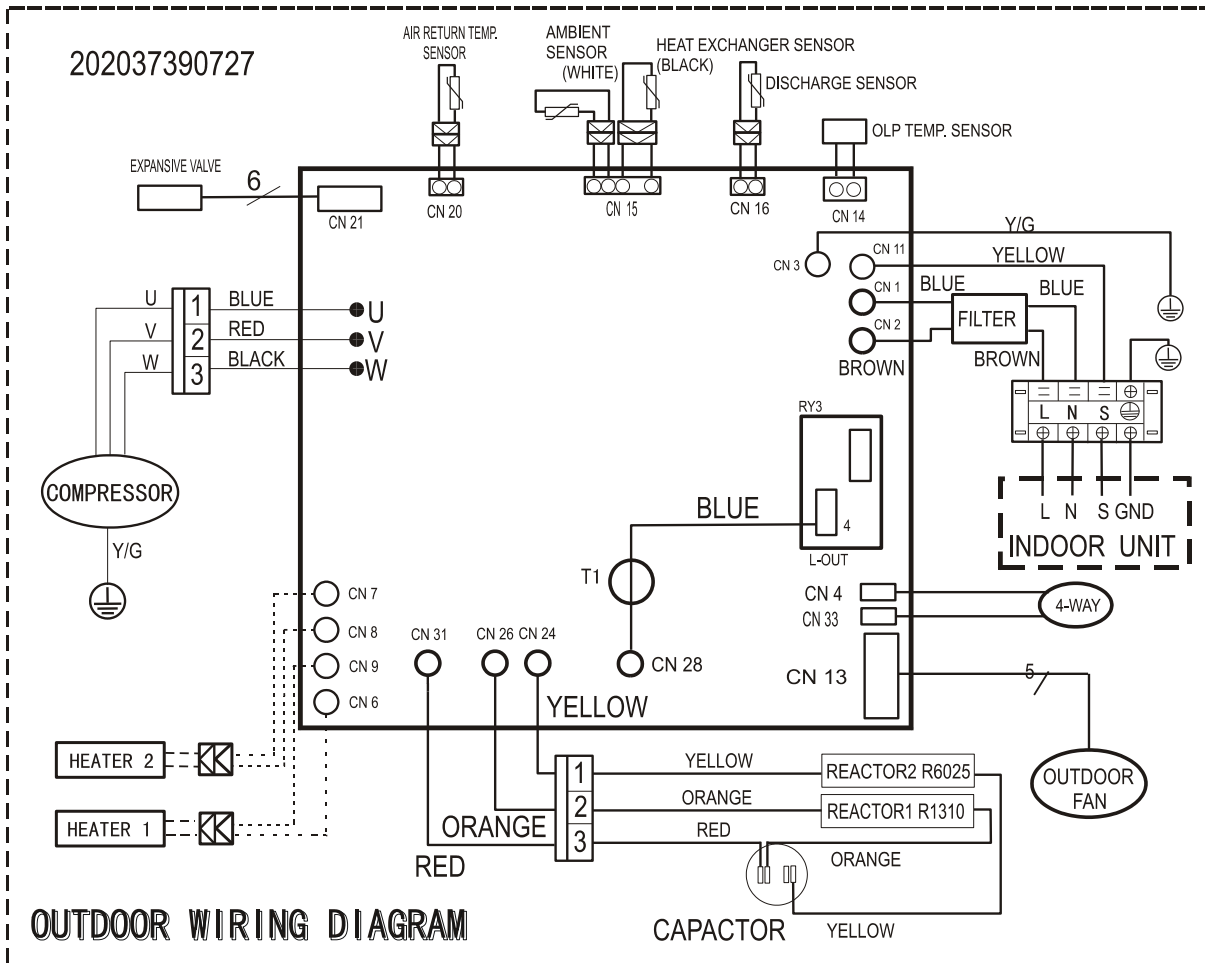

## 6. Installation details

### 6.1 Wrench torque sheet for installation

Outside diameter		Torque	Additional tightening torque
mm	inch	N.cm	N.cm
Φ6.35	1/4	1500 (153kgf.cm)	1600 (163kgf.cm)
Φ9.52	3/8	2500 (255kgf.cm)	2600 (265kgf.cm)

### 6.2 Connecting the cables

The power cord of connect should be selected according to the following specifications sheet.

Rated current of appliance	Nominal cross-sectional area (mm <sup>2</sup> )
>3 and ≤6	0.75
>6 and ≤10	1.0
>10 and ≤16	1.5
>16 and ≤25	2.5

The cable size and the current of the fuse or switch are determined by the maximum current indicated on the nameplate which located on the side panel of the unit. Please refer to the nameplate before selecting the cable, fuse and switch.



### 6.3 Pipe length and the elevation

The pipe length and refrigerant amount:

Model	Connective pipe length	Air purging	Additional amount of refrigerant
All	Less than 5m	Use vacuum pump	-----
MS1Ai-09HRFN1  MS1Ai-12HRFN1	More than 5m	Use vacuum pump	(Pipe length – 5) × 20g/m

Model		Standard length (m)	Max. Elevation B (m)	Max. Length A (m)
MS1Ai-09HRFN1	MS1Ai-12HRFN1	5	8	20

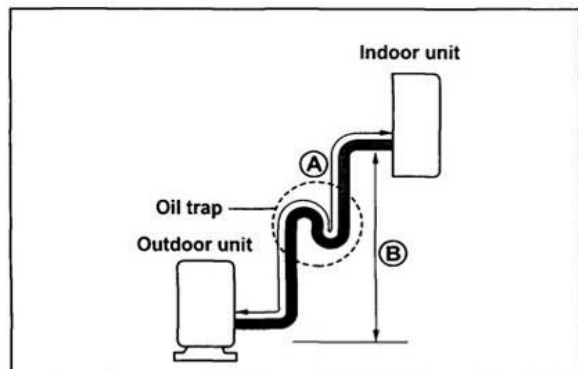
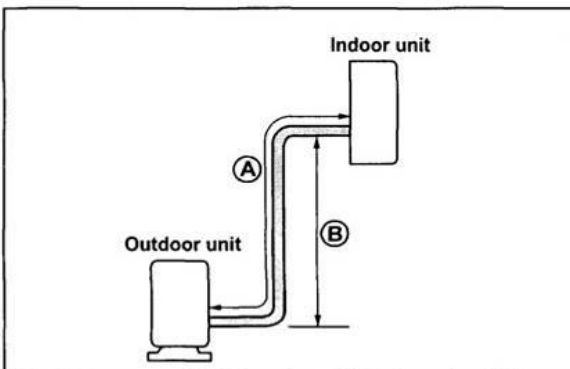

**Caution:**

Capacity test is based on standard length and maximum allowance length is based on system reliability. Oil trap should be installed per 5-7 meters.

## 6.4 Air purging with vacuum pump

Air and moisture in the refrigerant system have undesirable effects as below:

- Pressure in the system rises.
- Operating current rises.
- Cooling or heating efficiency drops.
- Moisture in the refrigerant circuit may freeze and block capillary tubing.
- Water may lead to corrosion of parts in the refrigerant system.

Therefore, the indoor units and the pipes between indoor and outdoor units must be leak tested and evacuated to remove gas and moisture from the system.

### Air purging with vacuum pump

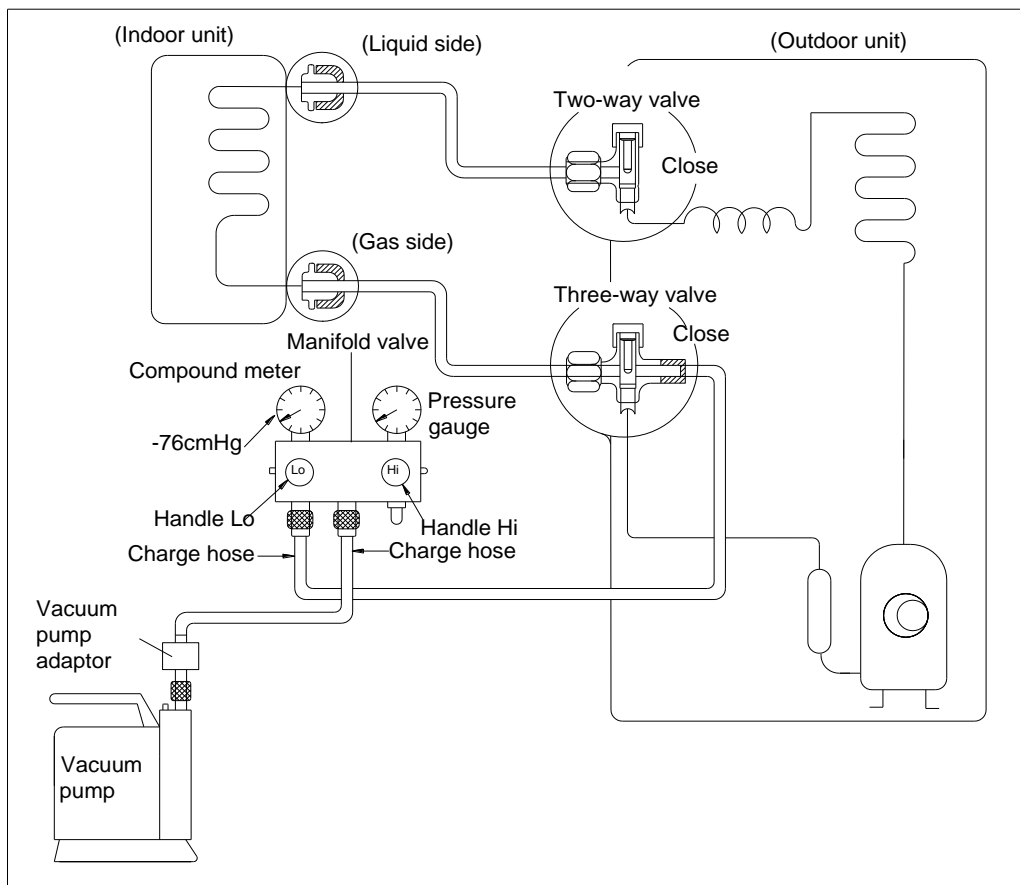

### Procedure

1. Completely tighten the flare nuts of the indoor and outdoor units, connect the manifold valve charge.
2. Connect the charge hose connection to the vacuum pump.
3. Fully open the handle Lo of the manifold valve.
4. Operate the vacuum pump to evacuate. After starting evacuation, slightly loose the flare nut of the Lo valve on the gas pipe side and check the air is entering. (Operation noise of the vacuum pump changes and a compound meter indicates 0 instead of minutes)
5. After the evacuation is complete, fully close the handle Lo valve of the manifold valve and stop the operation of the vacuum pump. Make evacuation for 15 minutes or more and check the compound meter indicates -76cmHg.
6. Turn the stem of the Hi valve about 45° counterclockwise for 6 or 7 seconds after the gas coming

out, then tighten the flare nut again. Make sure the pressure display in the pressure indicator is a little higher than the atmosphere pressure.

7. Remove the charge hose from the Lo pressure charge hose.
8. Fully open the Hi and Lo packed valve.
9. Securely tighten the cap of the packed valve.

### Gas leak check

Soap water method

Apply soap water or a liquid neutral detergent on the indoor unit connections or outdoor unit connections by a soft brush to check for leakage of the connecting points of the piping. If bubbles come out, the pipes have leakage.

## 6.5 Pumping down (Re-installation)

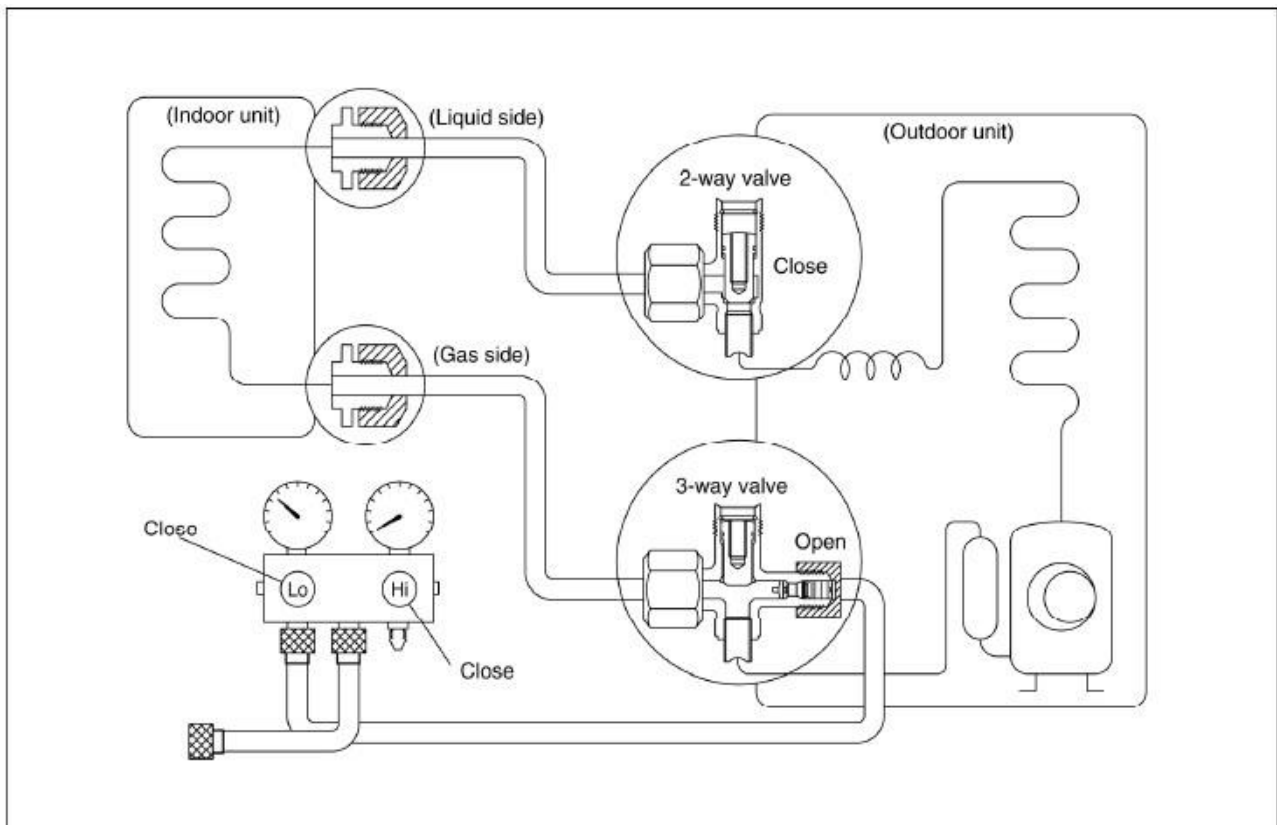

### Procedure

1. Confirm that both the 2-way and 3-way valves are set to the opened position.

Remove the valve stem caps and confirm that the valve stems are in the opened position.

Be sure to use a hexagonal wrench to operate the valve stems.

2. Operate the unit for 10 to 15 minutes.

3. Stop operation and wait for 3 minutes, then connect the charge set to the service port of the 3-way valve.

Connect the charge hose with the push pin to the gas service port.

4. Air purging of the charge hose.

- Open the low-pressure valve on the charge set slightly to purge air from the charge hose.
- Set the 2-way valve to the close position.
  - Operate the air conditioner at the cooling cycle and stop it when the gauge indicates 0.1MPa.
  - Set the 3-way valve to the closed position immediately.

Do this quickly so that the gauge ends up indicating 0.3 to 0.5Mpa.

Disconnect the charge set, and amount the 2-way and 3-way valve's stem nuts and service port caps.

Use a torque wrench to tighten the service port cap.

Be sure to check for gas leakage.

## 6.6 Re-air purging (Re-installation)

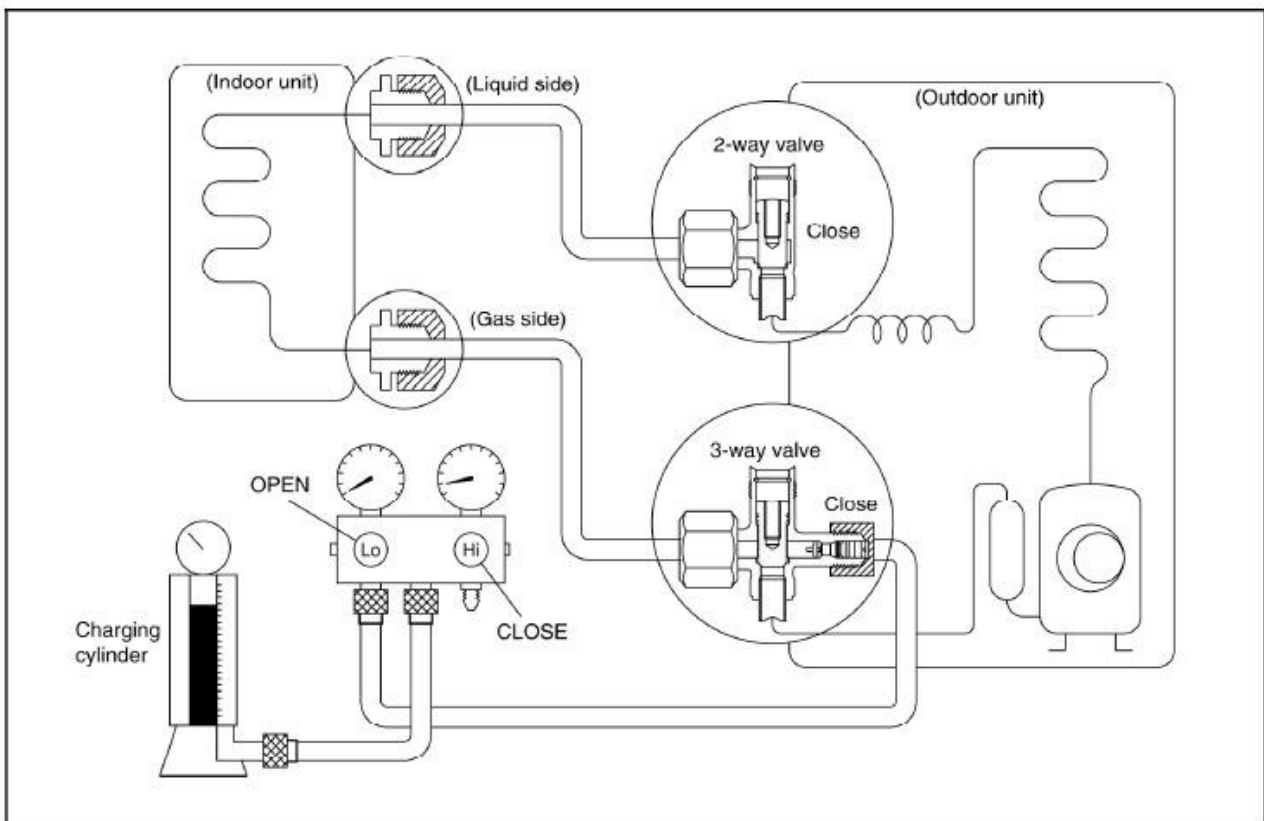

### Procedure:

- Confirm that both the 2-way and 3-way valves are set to the closed position.
- Connect the charge set and a charging cylinder to the service port of the 3-way valve.

Leave the valve on the charging cylinder closed.

### 3. Air purging.

Open the valves on the charging cylinder and the charge set. Purge the air by loosening the flare nut on the 2-way valve approximately 45° for 3 seconds then closing it for 1 minute; repeat 3 times.

After purging the air, use a torque wrench to tighten the flare nut to on the 2-way valve.

4. Check the gas leakage.

Check the flare connections for gas leakage.

5. Discharge the refrigerant.

Close the valve on the charging cylinder and discharge the refrigerant until the gauge indicates 0.3 to 0.5 Mpa.

6. Disconnect the charge set and the charging cylinder, and set the 2-way and 3-way valves to the open position.

Be sure to use a hexagonal wrench to operate the valve stems.

7. Mount the valve stems nuts and the service port cap.

Be sure to use a torque wrench to tighten the service port cap. Be sure to check the gas leakage.

## 6.8 Evacuation

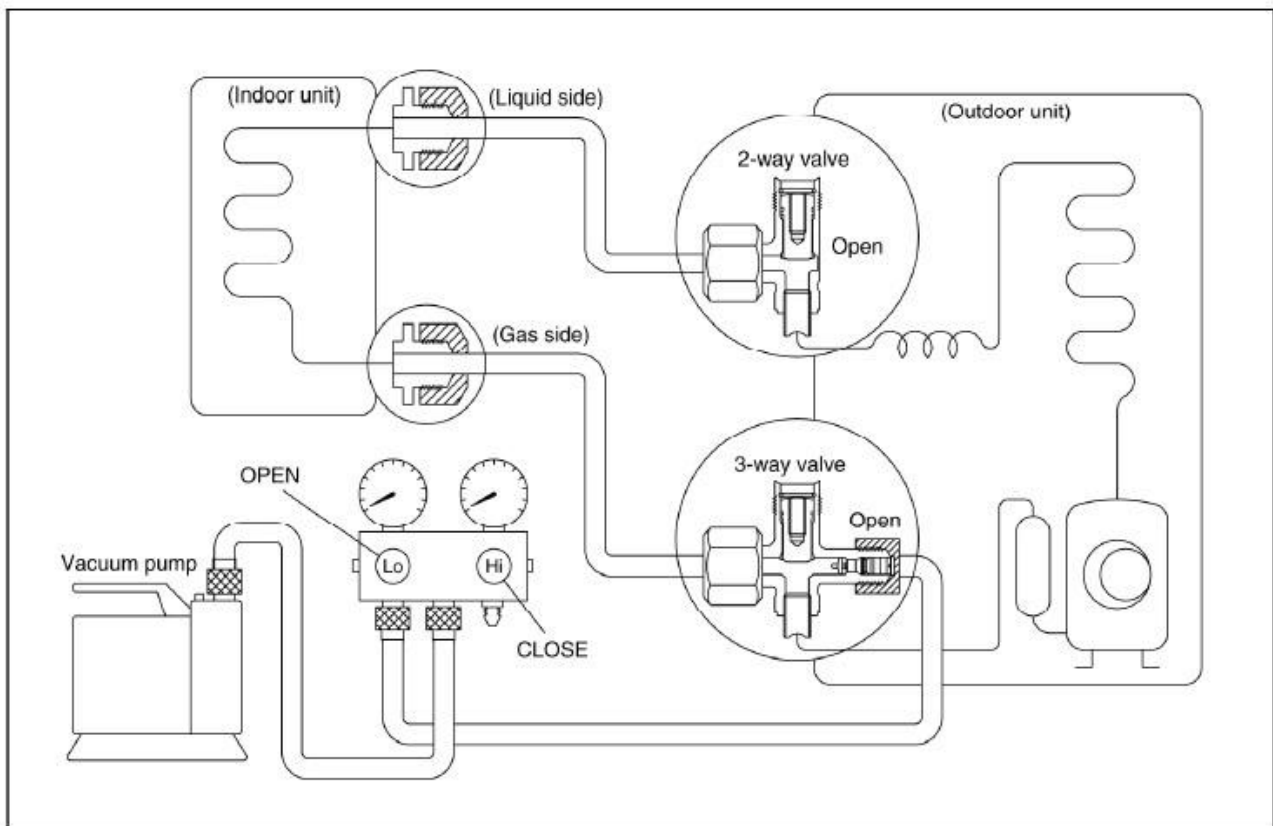

### Procedure:

1. Connect the vacuum pump to the charge set's center hose.

2. Evacuation for one hour approximately.

Confirm that the gauge needle has moved toward -0.1 Mpa (-76 cmHg) [vacuum of 4 mmHg or less].

3. Close the valve (Low side) on the charge set, turn off the vacuum pump, and confirm that the gauge needle does not move (approximately 5 minutes after turning off the vacuum pump).

4. Disconnect the charge hose from the vacuum pump.

## 6.9 Gas charging

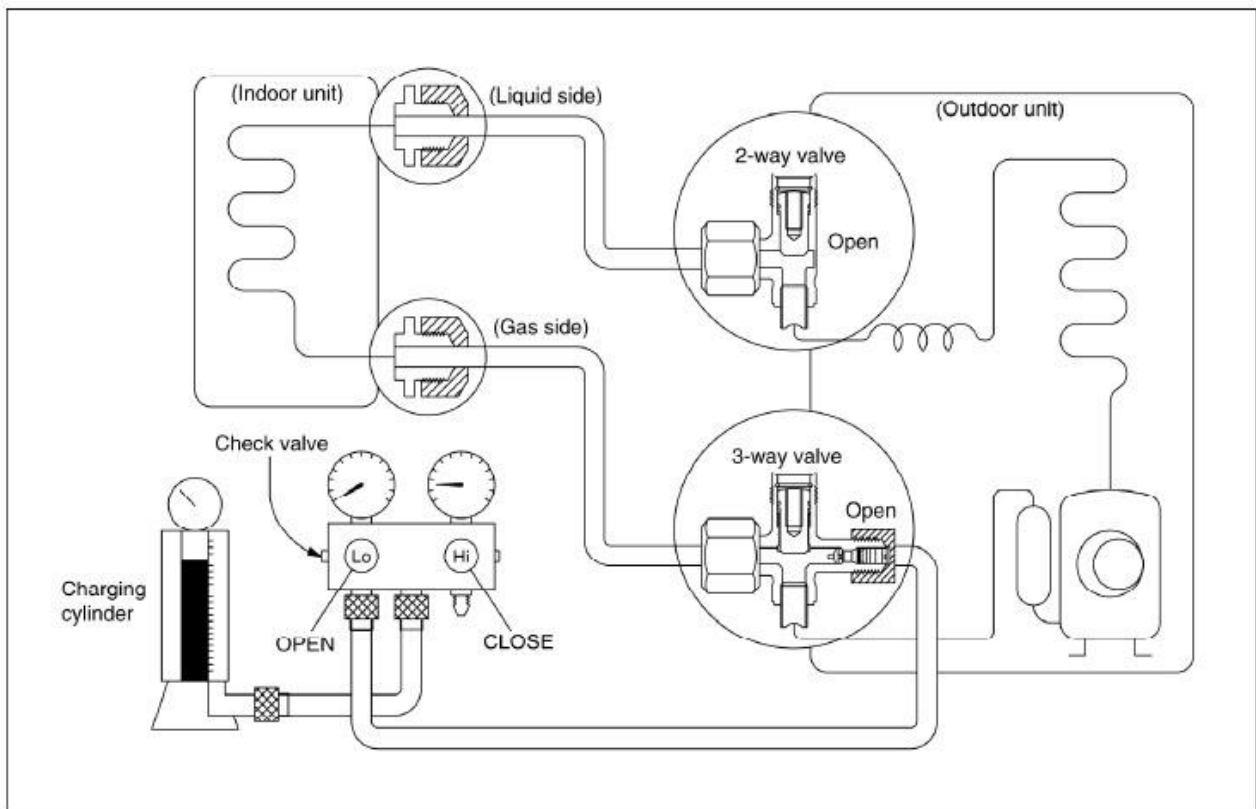

### Procedure:

1. Connect the charge hose to the charging cylinder.

Connect the charge hose which you disconnected from the vacuum pump to the valve at the bottom of the cylinder. If the refrigerant is R410A, make the cylinder bottom up to ensure liquid charge.

2. Purge the air from the charge hose.

Open the valve at the bottom of the cylinder and press the check valve on the charge set to purge the air (be careful of the liquid refrigerant).

3. Open the valves (Low side) on the charge set and charge the system with liquid refrigerant.

4. Disconnect the charge hose from the 3-way valve's service port immediately.

Stopping partway will allow the refrigerant to be discharged.

If the system has been charged with liquid refrigerant while operating the air conditioner, turn off the air conditioner before disconnecting the hose.

5. Mounted the valve stem caps and the service port

Use torque wrench to tighten the service port cap.

Be sure to check for gas leakage.

## 7. Operation characteristics

Temperature Mode	Cooling operation	Heating operation	Drying operation
Room temperature	$\geq 17^{\circ}\text{C}$	$\leq 30^{\circ}\text{C}$	$> 10^{\circ}\text{C}$
Outdoor temperature	$-15^{\circ}\text{C} \sim 50^{\circ}\text{C}$	$-20^{\circ}\text{C} \sim 34^{\circ}\text{C}$	$0^{\circ}\text{C} \sim 50^{\circ}\text{C}$

### CAUTION:

1. If air conditioner is used outside of the above conditions, certain safety protection features may come into operation and cause the unit to function abnormally.

2. Room relative humidity less than 80%. If the air conditioner operates in excess of this figure, the surface of the air conditioner may attract condensation. Please set the vertical air flow louver to its maximum angle (vertically to the floor), and set HIGH fan mode.

3. Optimum performance will be achieved within this operating temperature.

## 8. Electronic function

### 8.1 Abbreviation

T1: Indoor ambient temperature

T2: Coil temperature of indoor heat exchanger

T3: Coil temperature of outdoor heat exchanger







T4: Outdoor ambient temperature

T5: Compressor discharge temperature

### 8.2 Display function

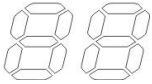
8.2.1 Icon explanation on indoor display board.



	<p><b>Auto indication lamp:</b> Lights up during the Auto operation.</p>
	<p><b>Defrost indication lamp:</b> This indicator illuminates when the air conditioner starts defrosting automatically or when the anti-cold wind function is activated in heating operation.</p>
	<p>DIGITAL DISPLAY indication lamp: <b>Displays current setting temperature or malfunction codes when the air conditioner is in operation.</b></p>
	<p><b>Run indication lamp:</b> This lamp illuminates when the air conditioner is in operation.</p>
	<p><b>Timer indication lamp:</b> Lights up during Timer operation.</p>
	<p><b>Ion indication lamp:</b> Illuminate when Ionizer/Plasma function is activated.</p>



## **8.3 Main Protection**

### **8.3.1 Three Minutes Delay at restart for compressor.**

---- 1 minute delay for the 1<sup>st</sup> time start-up and 3 minutes delay for others.

### **8.3.2 Temperature protection of compressor top.**

---- Top temp. protector cut off for 30s and restart the compressor with 3 minutes delay.

### **8.3.3 Temperature protection of compressor discharge.**

When the compressor discharge temp. is getting higher, the running frequency will be limited as below rules:

---- Compressor discharge temp.  $T_5 > 115^\circ\text{C}$  for 5s, compressor stops.

----  $108 < T_5 < 115^\circ\text{C}$ , decrease the frequency to the lower level every 3 minutes.

----  $90 < T_5 < 105^\circ\text{C}$ , keep running at the current frequency.

### **8.3.4 Fan Speed is out of control.**

----When Indoor Fan Speed keeps too low or too high for certain time, the unit will stop and the LED will display the failure

### **8.3.5 Inverter module Protection.**

----The Inverter module itself has a protection function against current, voltage and temperature. If these protections happen, the corresponding code will display on indoor unit.

### **8.3.6 Indoor fan delayed open function**

----When the system starts up, the louver will be active immediately and the indoor fan will open 10s later.

----If the system runs in heating mode, the indoor fan will be also controlled by anti-cold wind function.

### **8.3.7 Compressor preheating functions.**

----Preheating permitting condition:

If  $T_4$ (outdoor ambient temperature)  $< 3^\circ\text{C}$  and the machine connects to power supply newly or if  $T_4 < 3^\circ\text{C}$  and compressor has stopped for over 3 hours, the compressor heating cable will work.

----Preheating mode:

A weak current flow through the coil of compressor from the wiring terminal of compressor, then the compressor is heated without operation.

----Preheating release condition:

If  $T_4 > 5^\circ\text{C}$  or the compressor starts running, preheating function will stop.

## 8.4 Operation Modes and Functions

### 8.4.1 Fan mode.

- (1) Outdoor fan and compressor stop.
- (2) Temperature setting function is disabled, and no setting temperature is displayed.
- (3) Indoor fan can be set to high/med/low/auto.
- (4) The louver operates same as in cooling mode.
- (5) Auto fan:

The action of auto fan in fan-only mode is the same as auto fan in cooling mode with 24°C setting temperature.

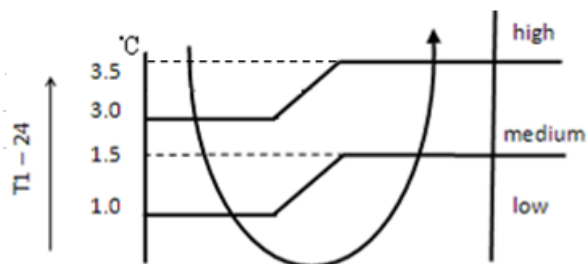

### 8.4.2 Cooling Mode

#### 8.4.2.1 Compressor running rules:

The operation frequency of compressor after starting submits to following rule.

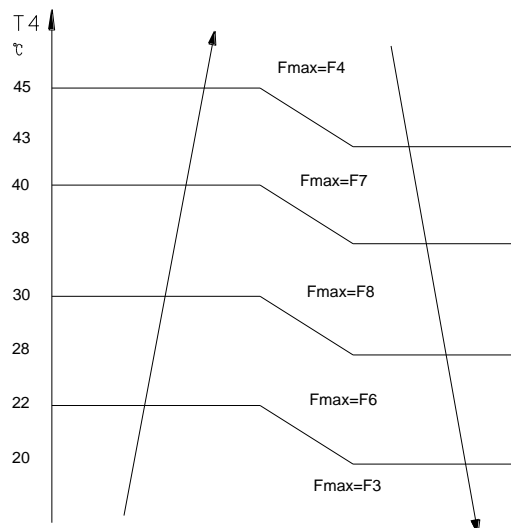

If users switch on AC by remote controller, the compressor will run at the Fmax frequency for 7 minutes according to outdoor ambient temp. During the 7 minutes, frequency limitation is active.

7 minutes later, the compressor running frequency will be controlled as below:

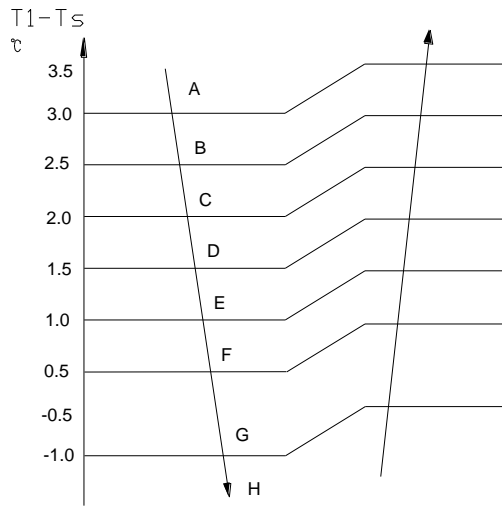

While

Temp.zone	A	B	C	D	E	F	G
Frequency	F8	F8	F7	F6	F5	F3	F1

**Note:**

When T1-Ts keeps in the same temp.zone for 3 minutes, the compressor will run as the below rules:

A~E: Increase the frequency to the higher level until to F8.

F: Keep the current frequency.

G: Decrease the frequency to the lower level until to F1.

H: Run at F1 for 1h.(if T1-Ts<-2°C, compressor will stop)

Meanwhile, the compressor running frequency is limited by the current.

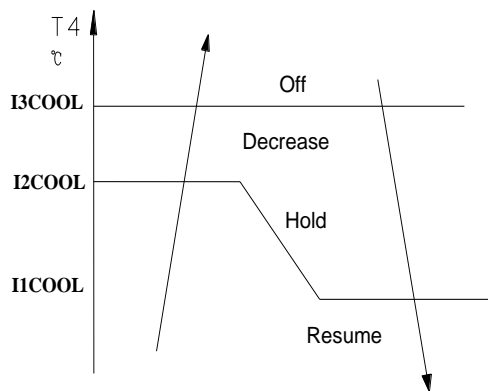

Off: Compressor stop.

Decrease: Decrease the running frequency to the lower level.

Hold:Keep the current frequency.

Resume:No limitation for frequency.

**Note:**

When AC is in “hold” zone for 3 minutes, the compressor frequency will rise to the higher level.(frequency will increase twice at most)

**8.4.2.2 Outdoor fan running rules:**

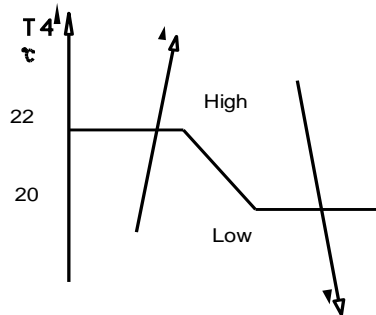

**8.4.2.3 Indoor fan running rules**

In cooling mode, indoor fan runs all the time and the speed can be selected as high, medium, low and auto.

Auto fan in cooling mode acts as follow:

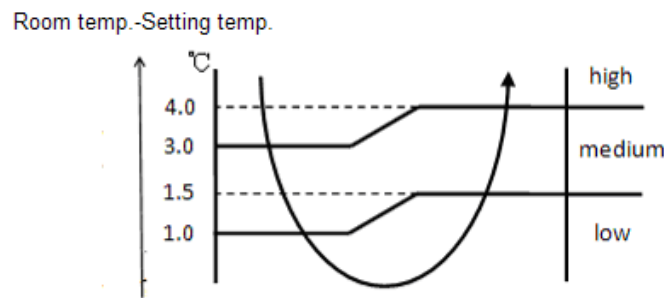

**8.4.2.4 Condenser high temperature T3 protection.**

When  $55^{\circ}\text{C} < T3 < 60^{\circ}\text{C}$ , the compressor frequency will decrease to the lower level until to F1 and then runs at F1.

When  $T3 < 54^{\circ}\text{C}$ , the compressor will keep running at the current frequency.

When  $T3 < 52^{\circ}\text{C}$ , the compressor will not limit the frequency and resume to the former frequency.

When  $T3 > 60^{\circ}\text{C}$  for 5 seconds, the compressor will stop until  $T3 < 52^{\circ}\text{C}$ .

**8.4.2.5 Evaporator low temperature T2 protection.**

When  $T2 < 0^{\circ}\text{C}$ , the compressor will stop and restart when  $T2 \geq -5^{\circ}\text{C}$ .

When  $0^{\circ}\text{C} \leq T2 < 4^{\circ}\text{C}$ , the compressor frequency will be limited and decreased to the lower level every minute.

When  $4^{\circ}\text{C} \leq T2 \leq 7^{\circ}\text{C}$ , the compressor will keep the current frequency.

When  $T2 > 7^{\circ}\text{C}$ , the compressor frequency will not be limited.

### 8.4.3 Heating Mode

#### 8.4.3.1 Compressor running rules:

The operation frequency of compressor after starting submits to following rule.

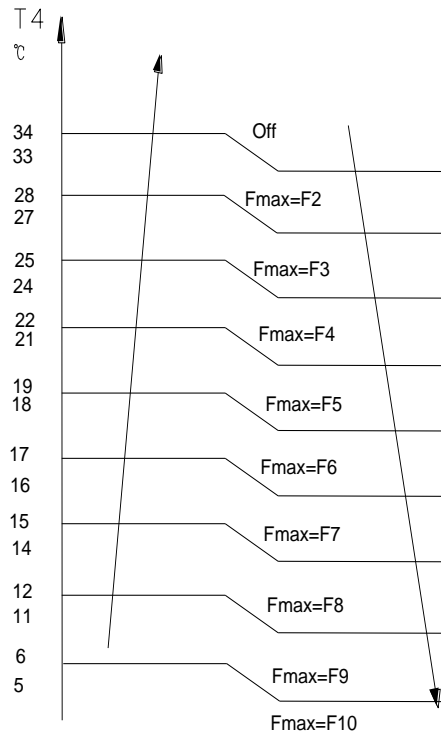

If users switch on AC by remote controller, the compressor will run at the Fmax frequency for 7 minutes according to outdoor ambient temp. During the 7 minutes, frequency limitation is active.

7 minutes later, the compressor running frequency will be controlled as below:

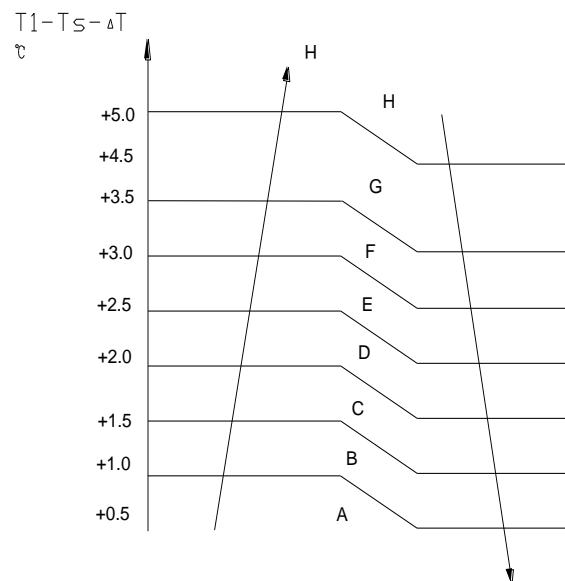

While

Temp.zon	A	B	C	D	E	F	G
Frequenc	F10	F9	F8	F7	F5	F3	F1

$\Delta T=0^{\circ}\text{C}$  as default.

**Note:**

When  $T_1-T_s$  keeps in the same temp. zone for 3 minutes, the compressor will run as the below rules:

A~E: Increase the frequency to the higher level until to F10.

F: Keep the current frequency.

G: Decrease the frequency to the lower level until to F1.

H: Run at F1 for 1h.(if  $T_1-T_s-\Delta T > 6^{\circ}\text{C}$ , compressor will stop)

Meanwhile, the compressor running frequency is limited by the current.

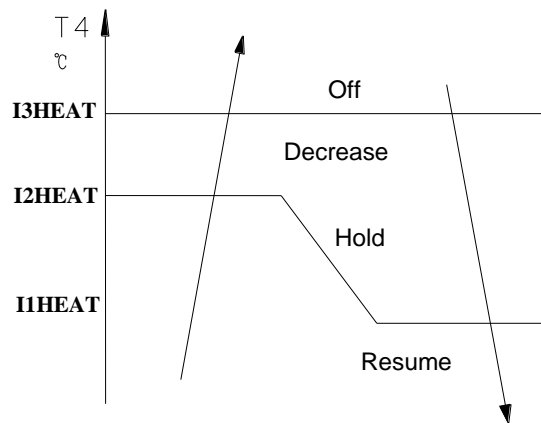

Off: Compressor stop.

Decrease: Decrease the running frequency to the lower level.

Hold: Keep the current frequency.

Resume: No limitation for frequency.

**Note:**

When AC is in "hold" zone for 3 minutes, the compressor frequency will rise to the higher level.(frequency will increase twice at most)

**8.4.3.2 Outdoor fan running rules:**

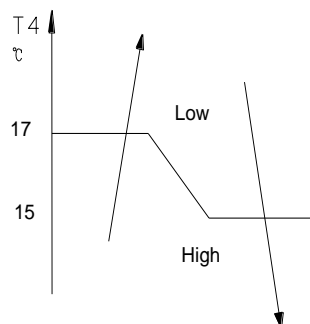

### 8.4.3.3 Indoor fan running rules:

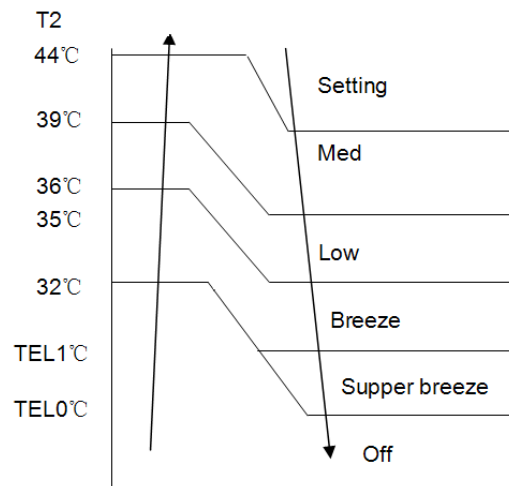

While

Model	TEL0 (°C)	TEL1 (°C)
All models	17	24

If the compressor stops caused by room temperature rising, the indoor fan will be forced to run 127 seconds with breeze. During this period, the anti-cold-wind is disabled.

If the machine runs in rating capacity test mode, the indoor fan will run with rating speed and the anti-cold-wind function is disabled.

Indoor fan speed can be set as high, medium, low or auto fan and the anti-cold-wind function is preferential.

Auto fan action in heating mode.

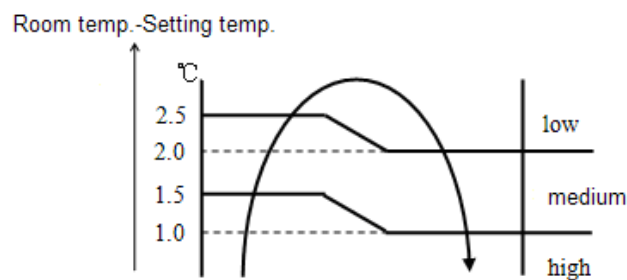

### 8.4.3.4 Defrosting mode:

#### Condition of defrosting:

Condition 1: If  $T_4 > 0^\circ\text{C}$ ,

When the units are running, if the following two items are satisfied, the units start defrosting:

The units run with  $T_3 < 3^\circ\text{C}$  for 40 minutes and  $T_3$  keeps lower than  $T_{CDI}$  for more than 3 minutes.

The units run with  $T_3 < 3^\circ\text{C}$  for 80 minutes and  $T_3$  keeps lower than  $T_{CDI} + 2^\circ\text{C}$  for more than 3 minutes. While  $T_{CDI} = -6^\circ\text{C}$ .

Condition 2: If  $T4 < 0^{\circ}\text{C}$ ,

If the 1<sup>st</sup> condition and 2<sup>nd</sup> condition items are satisfied, then the program judges if T2 has decreased more than  $5^{\circ}\text{C}$ . When T2 has decreased more than  $5^{\circ}\text{C}$ , enter the defrosting mode.

Condition 3: No matter what value T4 is, if the machine runs with  $T3 < 3^{\circ}\text{C}$  for more than 120 minutes and T3 keeps lower than  $\text{TCDI} + 4^{\circ}\text{C}$  for more than 3 minutes, the machine will enter defrosting mode no matter if T2 drops more than  $5^{\circ}\text{C}$  or not.

### Condition of ending defrosting:

If any one of the following items is satisfied, the defrosting will finish and the machine will turn to normal heating mode.

- T3 rises to be higher than  $\text{TCDE}1^{\circ}\text{C}$
- T3 keeps to be higher than  $\text{TCDE}2^{\circ}\text{C}$  for 80 seconds.
- The machine has run for 10 minutes in defrosting mode.

While  $\text{TCDE}1 = 12^{\circ}\text{C}$ ,  $\text{TCDE}2 = 8^{\circ}\text{C}$  for MS1A-09HRFN1-QE0, MS1A-12HRFN1-QD2, MS1A-18HRFN1-QC6 models.  $\text{TCDE}1 = 15^{\circ}\text{C}$ ,  $\text{TCDE}2 = 8^{\circ}\text{C}$  for MS1A-24HRFN1-QC2W model.

### Defrosting action:

For MS1A-09HRFN1-QE0, MS1A-12HRFN1-QD2 models:

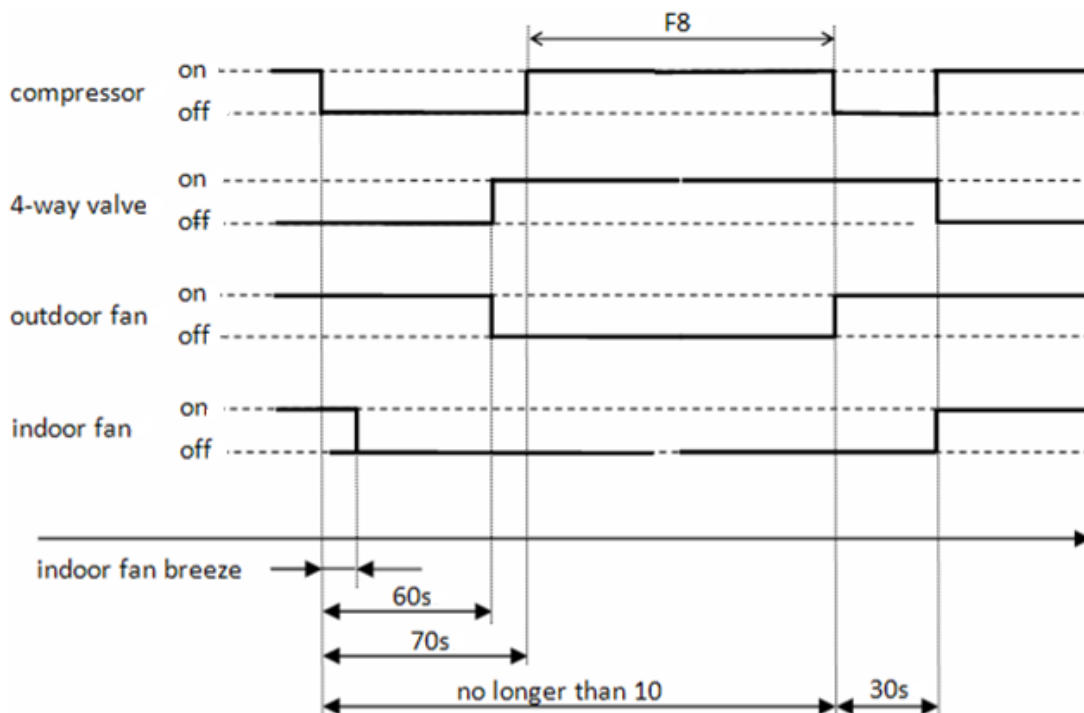



**8.4.3.5 High evaporator coil temp.T2 protection:**

(1)  $T_2 > TEH_2^{\circ}C$ , compressor running frequency decreases to the lower level and runs for 20s.

When the frequency decreases to F2 and the  $T_2$  is still over  $TEH_2^{\circ}C$  for 3 minutes, the compressor will stop.

(2) If  $T_2 < 48^{\circ}C$  or  $T_2$  stays in  $48^{\circ}C \sim TEH_2^{\circ}C$  for 6 minutes, the frequency will not be limited by  $T_2$ .

(3) If  $T_2 > 60^{\circ}C$ , the compressor will stop and restart when  $T_2 < 48^{\circ}C$

While  $TEH_2 = 53^{\circ}C$

**8.4.4 Auto-mode**

This mode can be chosen with remote controller and the setting temperature can be changed between  $17 \sim 30^{\circ}C$

In auto mode, the machine will choose cooling, heating or fan-only mode according to  $\Delta T$  ( $\Delta T = T_1 - T_s$ ).

$\Delta T = T_1 - T_s$	Running mode
$\Delta T > 1^{\circ}C$	Cooling
$-1 < \Delta T \leq 1^{\circ}C$	Fan-only
$\Delta T \leq -1^{\circ}C$	Heating

Indoor fan will run at auto fan of the relevant mode.

The louver operate same as in relevant mode.

If the machine switches mode between heating and cooling, the compressor will keep stopping for 15 minutes and then rechoose mode according to  $T_1 - T_s$ .

If the setting temperature is modified, the machine will rechoose running function.

### 8.4.5 Drying mode

8.4.5.1 Indoor fan speed is fixed at breeze and can't be changed. The louver angle is the same as in cooling mode.

8.4.5.2 Compressor running rules

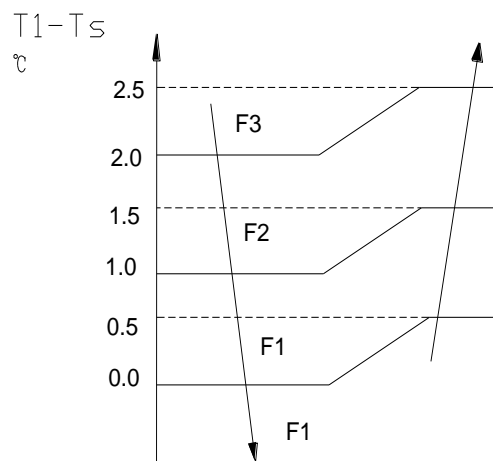

8.4.5.3 Room overflow temperature protection

In drying mode, if room temperature is lower than  $10^{\circ}\text{C}$ , the compressor will stop and not resume until room temperature exceeds  $12^{\circ}\text{C}$ .

8.4.5.4 Evaporator anti-freezing protection, condenser high temperature protection and outdoor unit frequency limit are active and the same as that in cooling mode.

8.4.5.5 The outdoor fan operates the same as in cooling mode.

### 8.4.6 Forced operation function

8.4.6.1 Enter forced operation function:

When the machine is off, pressing the touch button will carry the machine to forced auto mode, after this, if pressing the button once again within 5 seconds, the machine will turn into forced cooling mode.

In forced auto, forced cooling or any other operation mode, pressing touch button will turn off the machine.

8.4.6.2 In forced operation mode, all general protections and remote control are available.

8.4.6.3 Operation rules:

Forced cooling mode:

The compressor runs at F2 frequency and indoor fan runs as breeze. After running for 30 minutes, the

machine will turn to auto mode as 24°C setting temperature.

Forced auto mode:

The action of forced auto mode is the same as normal auto mode with 24°C setting temperature.

#### **8.4.7 Timer function**

8.4.7.1 Timing range is 24 hours.

8.4.7.2 Timer on. The machine will turn on automatically when reaching the setting time.

8.4.7.3 Timer off. The machine will turn off automatically when reaching the setting time.

8.4.7.4 Timer on/off. The machine will turn on automatically when reaching the setting “on” time, and then turn off automatically when reaching the setting “off” time.

8.4.7.5 Timer off/on. The machine will turn off automatically when reaching the setting “off” time, and then turn on automatically when reaching the setting “on” time.

8.4.7.6 The timer function will not change the AC current operation mode. Suppose AC is off now, it will not start up firstly after setting the “timer off” function. And when reaching the setting time, the timer LED will be off and the AC running mode has not been changed.

8.4.7.7 The setting time is relative time.

#### **8.4.8 Sleep function mode**

8.4.8.1 Operation time in sleep mode is 7 hours. After 7 hours the AC quits this mode and turns off.

8.4.8.2. Operation process in sleep mode is as follow:

When cooling, the setting temperature rises 1°C (be lower than 30°C) every one hour, 2 hours later the setting temperature stops rising and indoor fan is fixed as low speed.

When heating, the setting temperature decreases 1°C (be higher than 17°C) every one hour, 2 hours later the setting temperature stops rising and indoor fan is fixed as low speed. (Anti-cold wind function has the priority)

8.4.8.3 Timer setting is available

8.4.8.4 When user uses timer off function in sleep mode (or sleep function in timer off mode), if the timing is less than 7 hours, sleep function will be cancelled when reaching the setting time. If the timing is more than 7 hours, the machine will not stop until reaches the setting time in sleep mode.

#### **8.4.9 Auto-Restart function**

The indoor unit is equipped with auto-restart function, which is carried out through an auto-restart module. In case of a sudden power failure, the module memorizes the setting conditions before the

power failure. The unit will resume the previous operation setting (not including Swing function) automatically after 3 minutes when power returns.

If the memorization condition is forced cooling mode, the unit will run in cooling mode for 30 minutes and turn to auto mode as 24°C setting temp.

If AC is off before power off and AC is required to start up now, the compressor will have 1 minute delay when power on. Other conditions, the compressor will have 3 minutes delay when restarts.

#### **8.4.10 Ionizer/Plasma dust collector function (optional)**

The indoor unit is equipped with Ionizer, which is controlled by the CLEAN AIR button on the remote controller. When the unit is turned on, press the CLEAN AIR button to activate the function. Press it again to stop the function. During the time when Ionizer is controlled by remote controller, Ionizer will be turned off automatically if indoor fan stops running due to malfunctions or anti-cold-wind. When indoor fan restarts after malfunctions being eliminated and anti-cold-wind being released, Ionizer will be available again.

#### **8.4.11 Silence operation**

Press the "silence" button on remote controller to initiate SILENCE function. When the Silence function is activated, the compressor running frequency will keep lower than F2 and the indoor unit will bring faint breeze, which will reduce the noise to the lowest level and create a quiet and comfortable room for you.

## 9. Troubleshooting

### 9.1 Indoor Unit Error Display

Display	LED STATUS
E0	EEPROM parameter error
E1	Indoor / outdoor units communication protection
E2	Zero-crossing signal error
E3	Indoor fan speed out of control
E5	Open or short circuit of outdoor temperature sensor
E6	Open or short circuit of room or evaporator temperature sensor
E7	Outdoor fan speed out of control
P0	IBM malfunction or IGBT over-strong current protection
P1	Over voltage or too low voltage protection
P2	Temperature protection of compressor top.
P4	Inverter compressor drive error

**Note:** E4 & P3: Reserved function.

## 9.2 Diagnosis and Solution

### 9.2.1 EEPROM parameter error diagnosis and solution

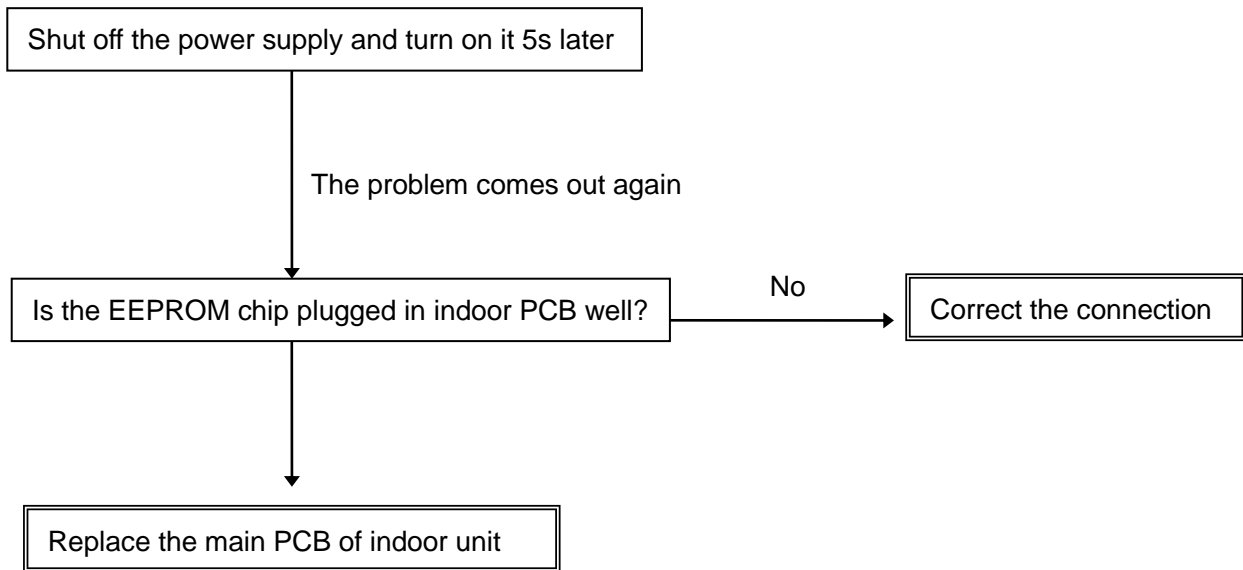

### 9.2.2 Indoor / outdoor units communication protection error diagnosis and solution

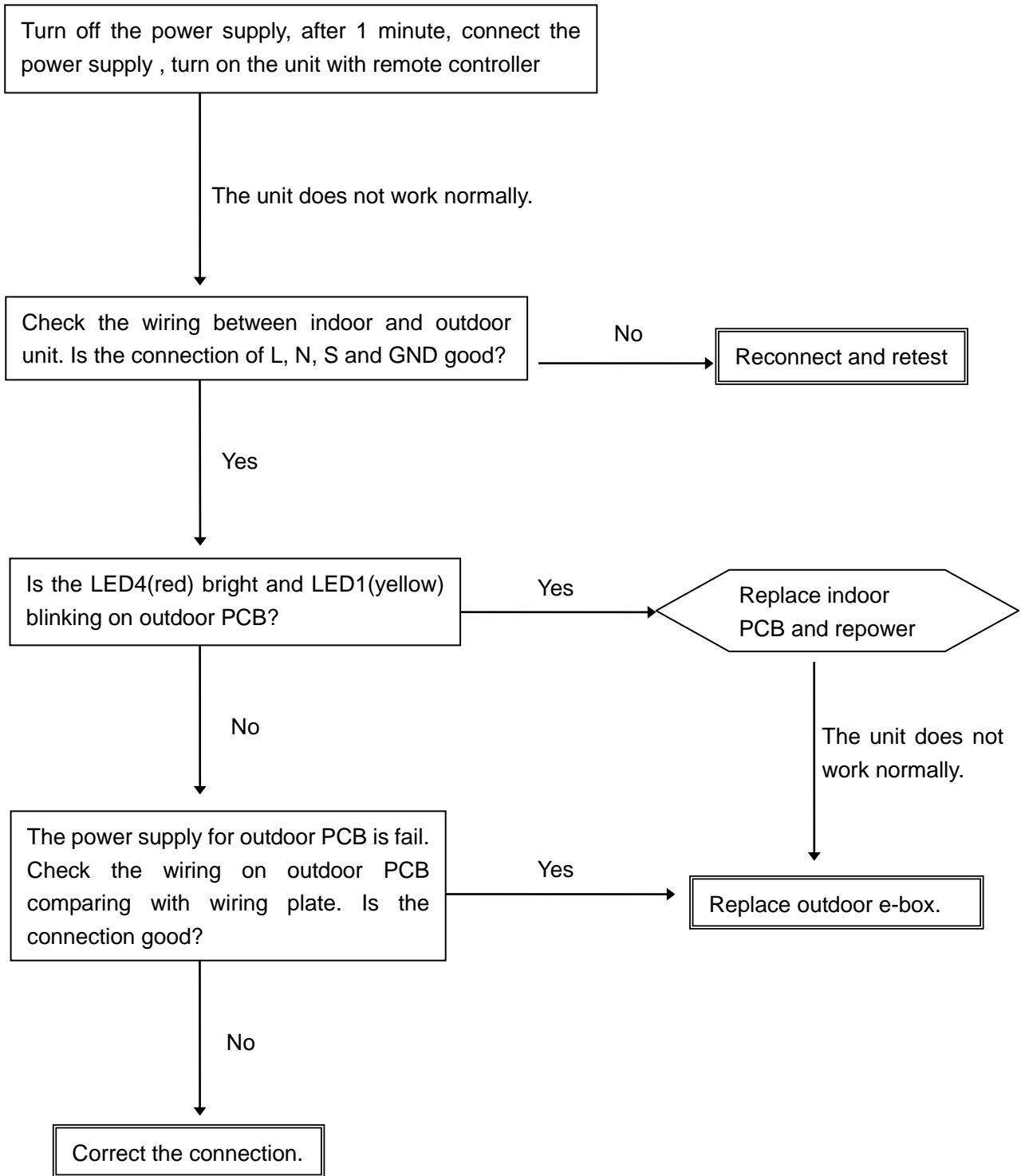

### 9.2.3 Fan speed out of control diagnosis

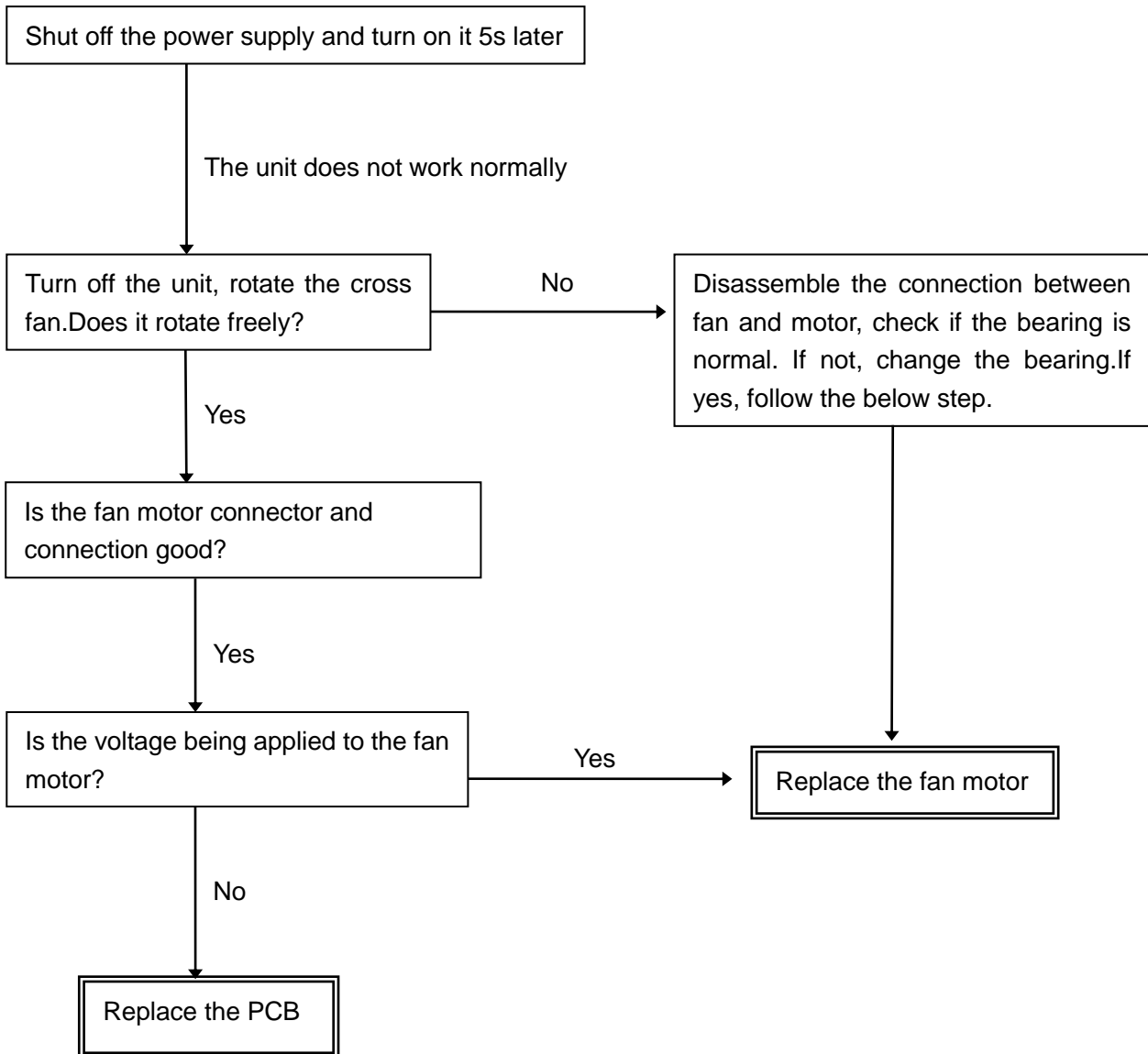

### 9.2.4 Open or short circuit of temperature sensor diagnosis and solution.

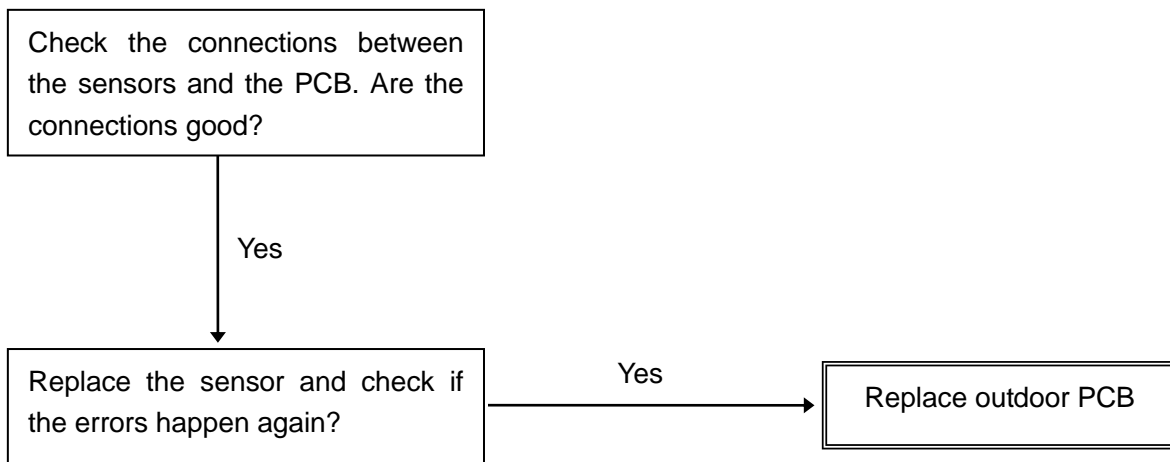



**9.2.5 IGBT over-strong current protection diagnosis and solution.**

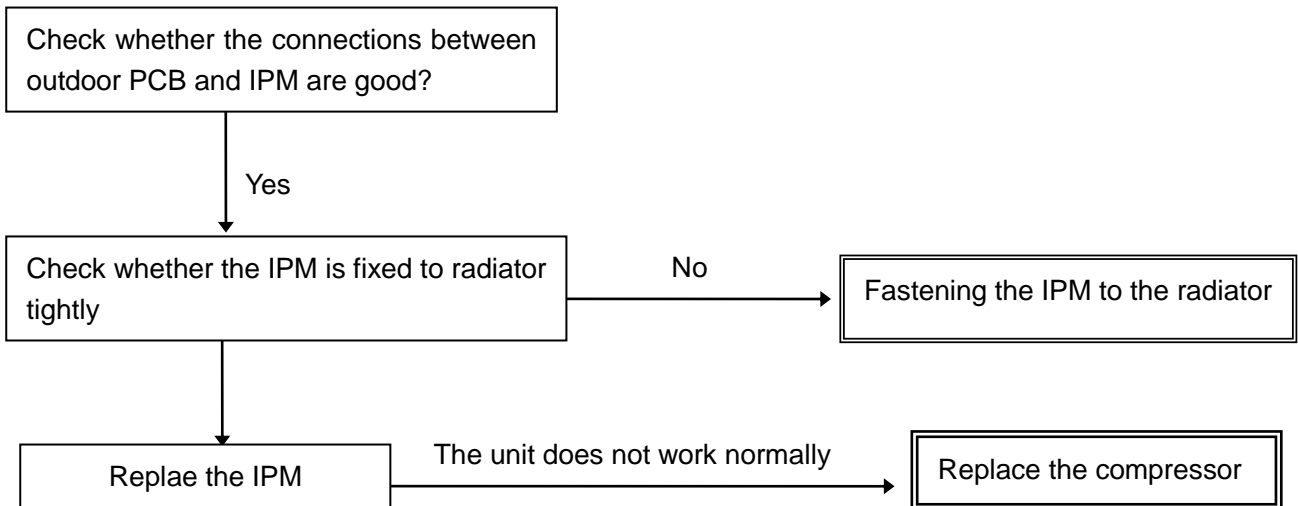

**9.2.6 Over voltage or too low voltage protection diagnosis and solution.**

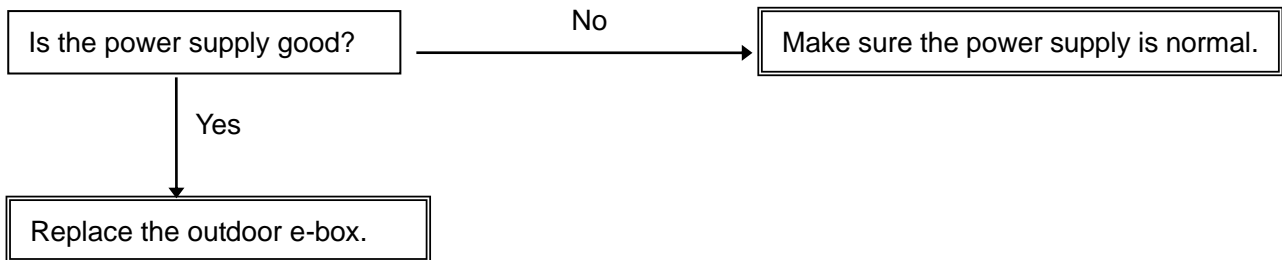

**9.2.7 High temperature protection of compressor top diagnosis and solution.**

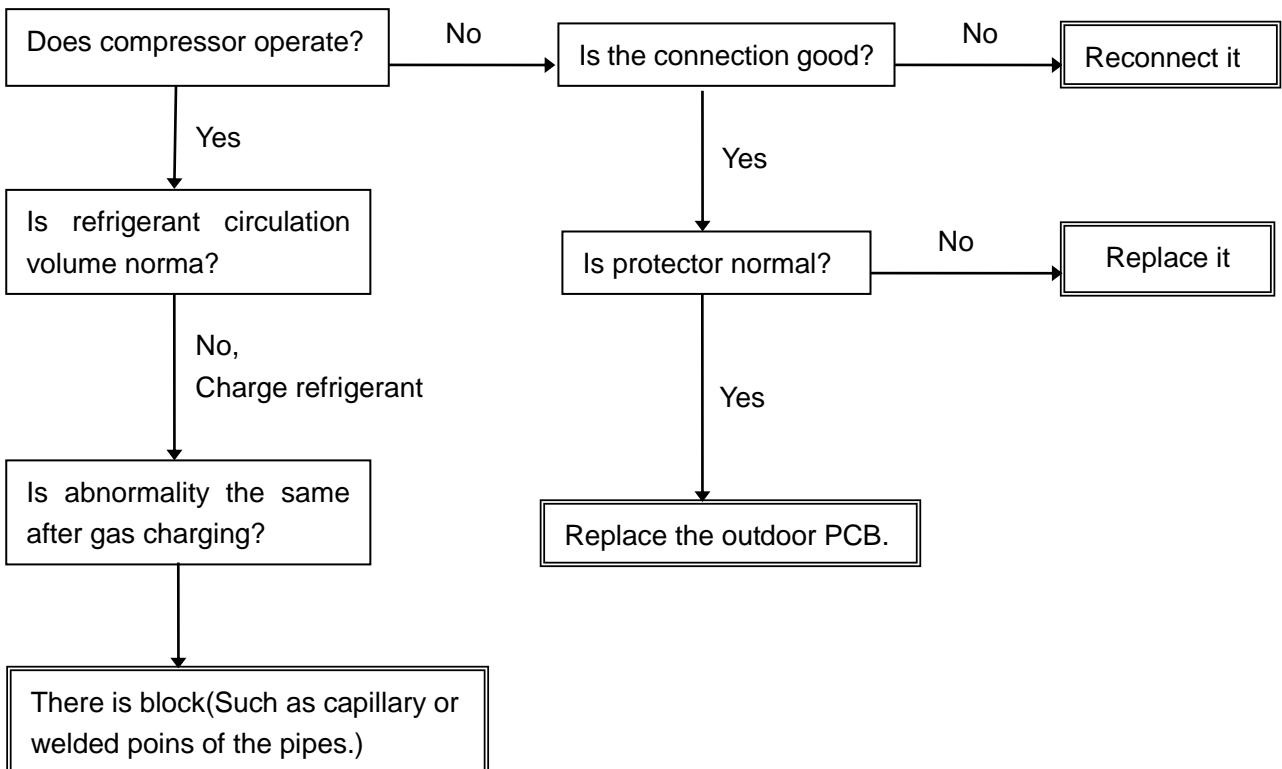

### 9.2.8 Inverter compressor drive error diagnosis and solution.

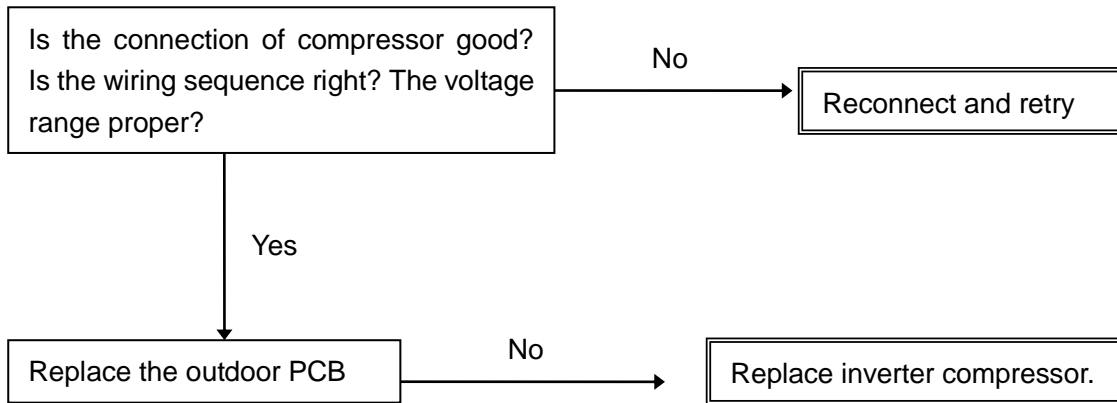

### 9.2.9 Zero crossing detection error

This is alarm signal when the main chip can't detect over-zero signal. When such failure occurs, the main control board must have fault.