

MULTI SPLIT TYPE, HEAT PUMP AIR CONDITIONERS

Technical service manual

R410A Multi DC inverter Indoor Unit

220~240V-1Ph-50Hz

Indoor Models

Cassette:

MDCA2I-07/09/12/18HRDN1

Console: MDFF-07/09/12/18HRDN1

A5 Duct: MDTBI-07/09/12/18HWDN1

3. Dimensions

3.1 Four-way cassette type(compact) (7000Btu/h/9000Btu/h /12000Btu/h /18000Btu/h) :

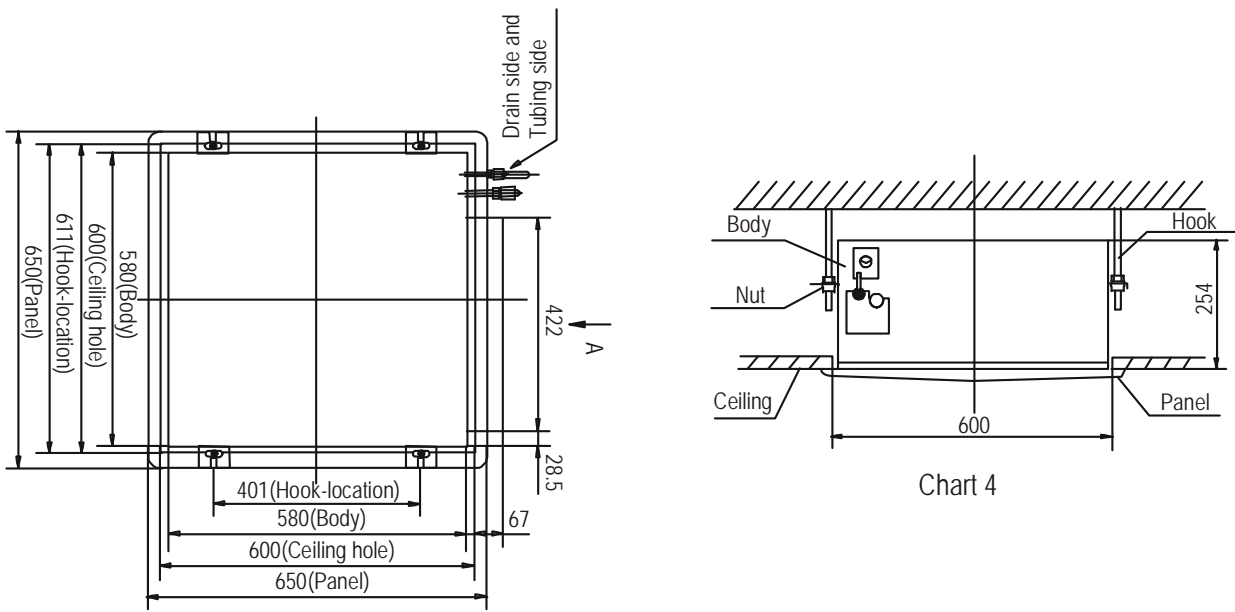
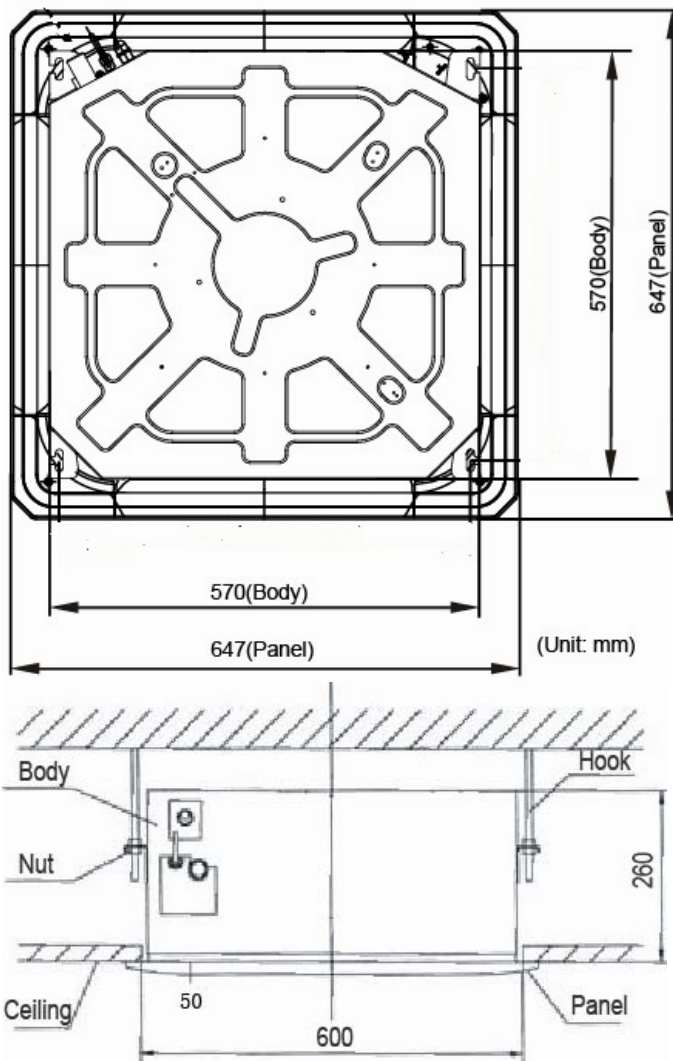

Chart 4

3.2 New Four-way cassette type(compact) (7000Btu/h/9000Btu/h /12000Btu/h /18000Btu/h) :



(Unit: mm)

3.4 A5 Duct

Outline dimension and air outlet opening size

Unit: mm

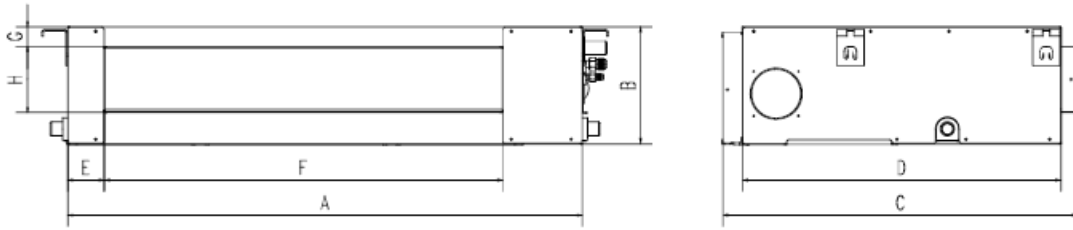

Air return opening size

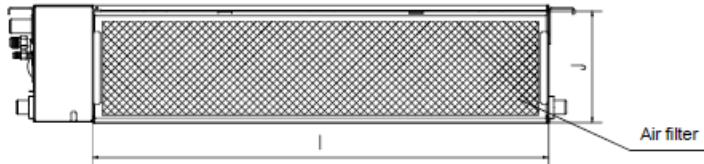

Position size of descensional ventilation opening

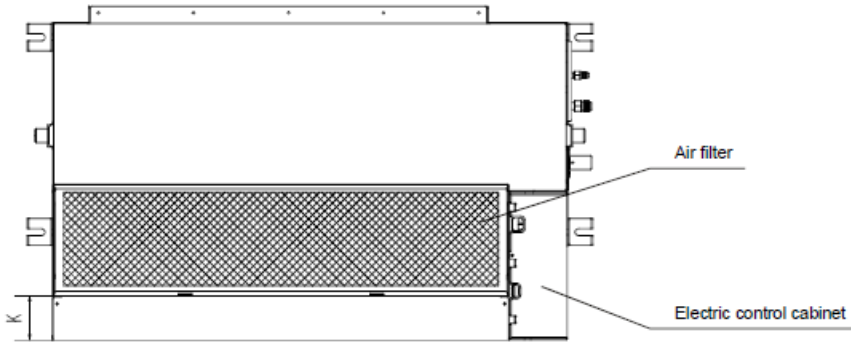

Size of mounted lug

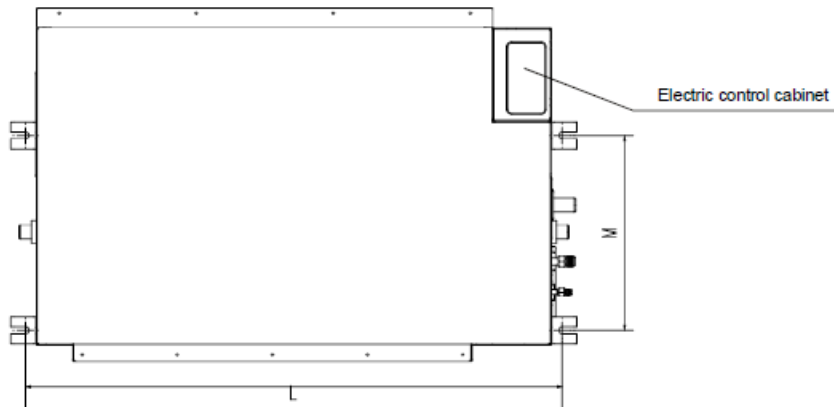

Capacity (KBtu)	Outline dimension(mm)				Air outlet opening size				Air return opening size			Size of outline dimension mounted plug	
	A	B	C	D	E	F	G	H	I	J	K	L	M
MDTBI-07HWDN1 MDTBI-09HWDN1 MDTBI-12HWDN1	700	210	635	570	65	493	35	119	595	200	80	740	350
MDTBI-18HWDN1	920	210	635	570	65	713	35	119	815	200	80	960	350

3.5 Console

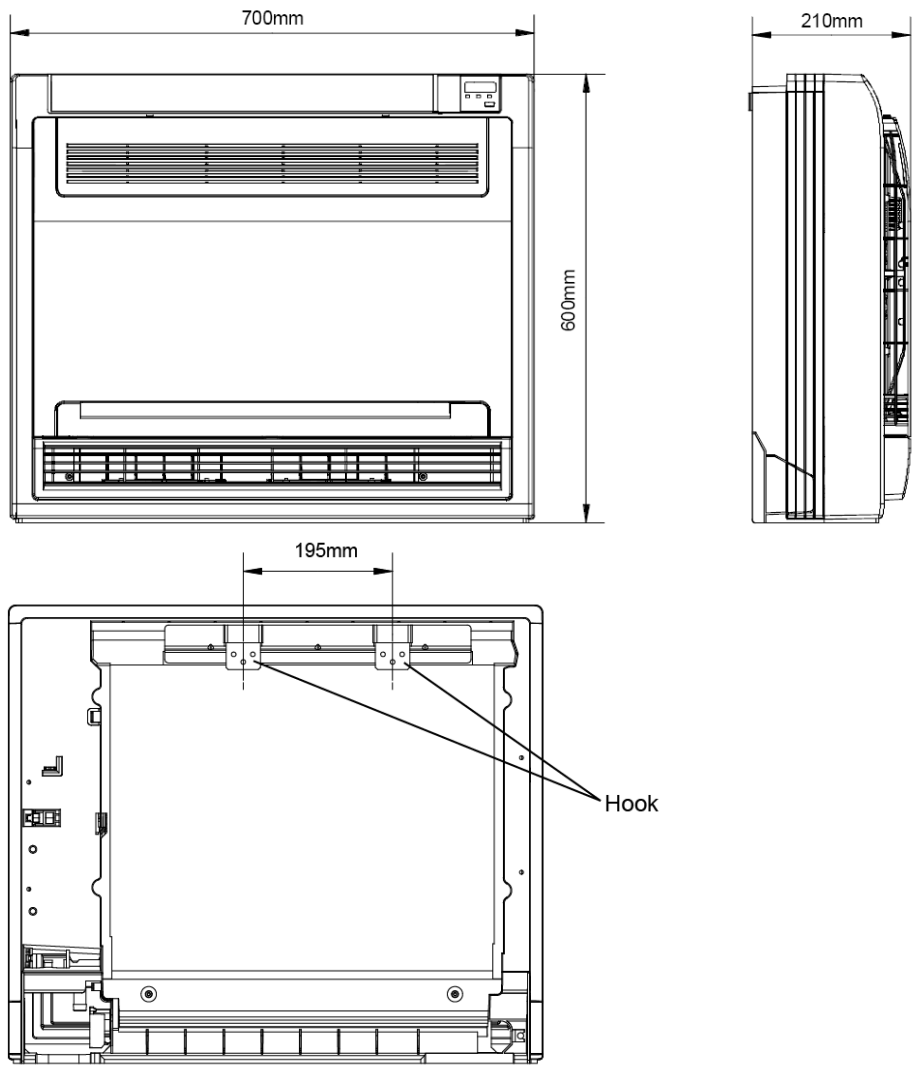

4. Service Space (unit: mm)

4.1 Four-way cassette(compact)

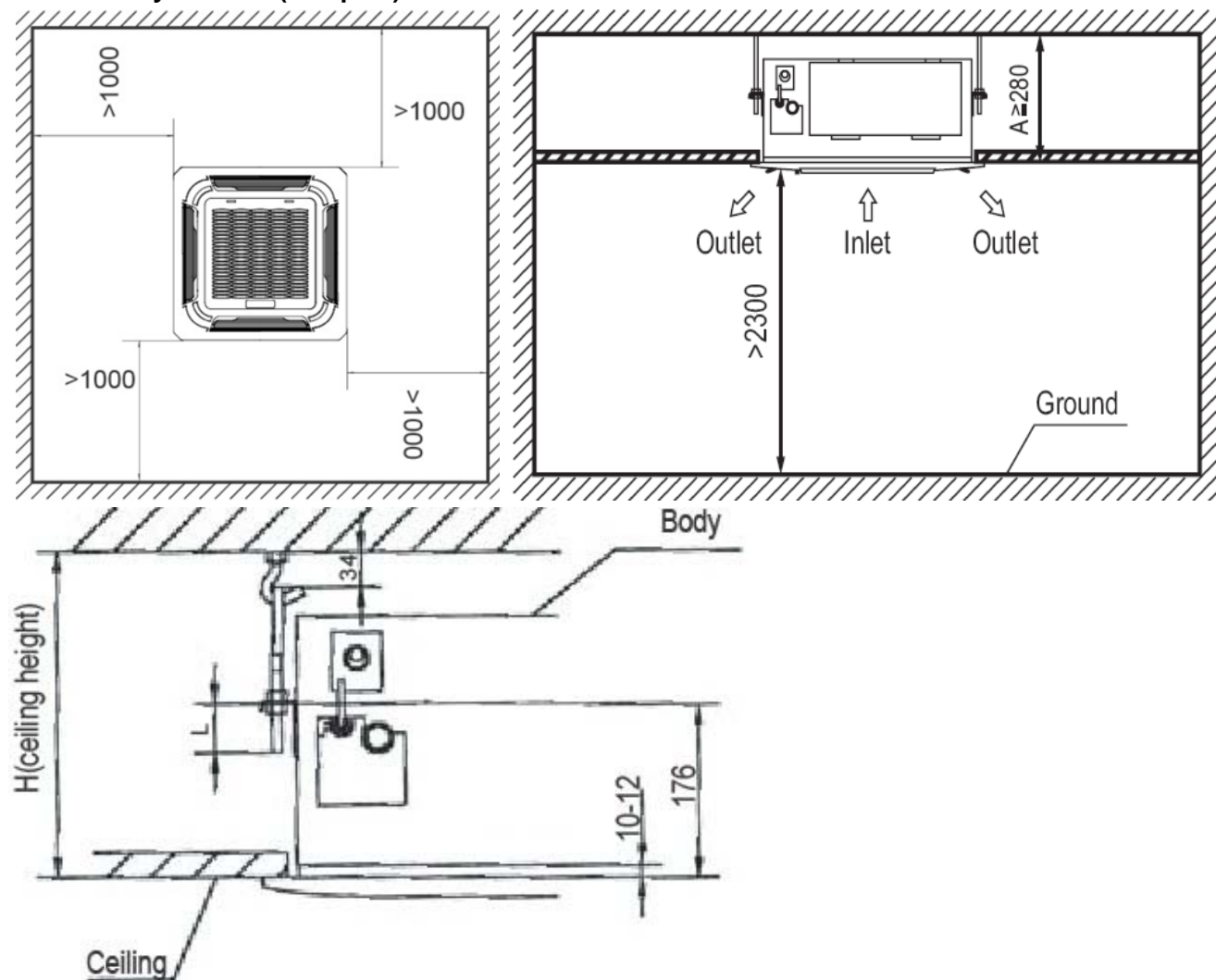

4.3 A5 Duct

Ensure enough space required for installation and maintenance.

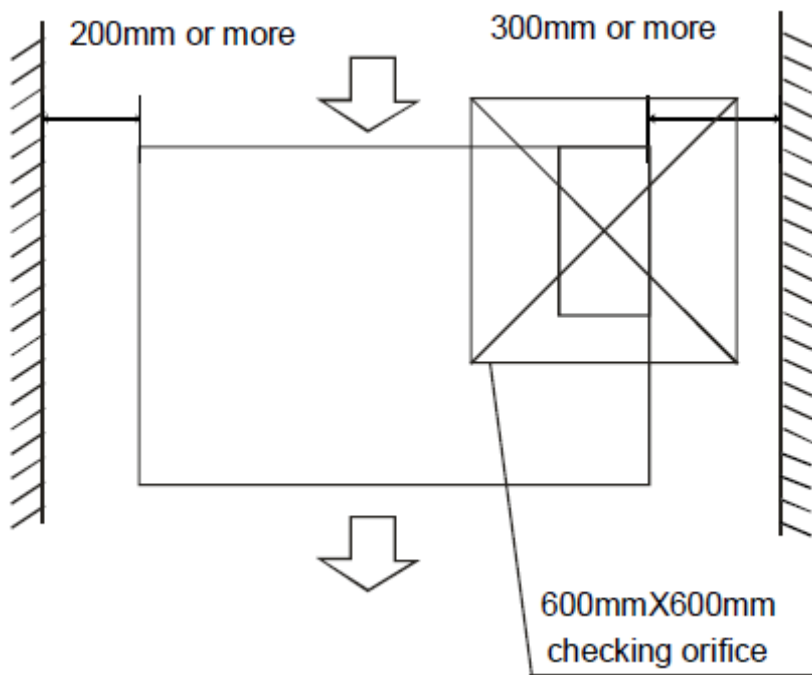

All the indoor units reserve the hole to joint the fresh air pipe. The hole size as following:

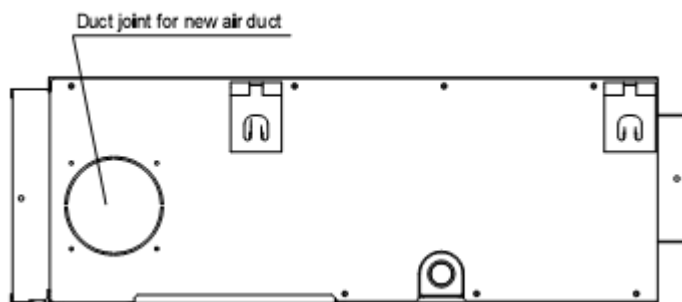

MODLE	
12-24	30-60
<p>Ø90mm 80mm 80mm</p>	<p>Ø125mm Ø160mm</p>

4.4 Console

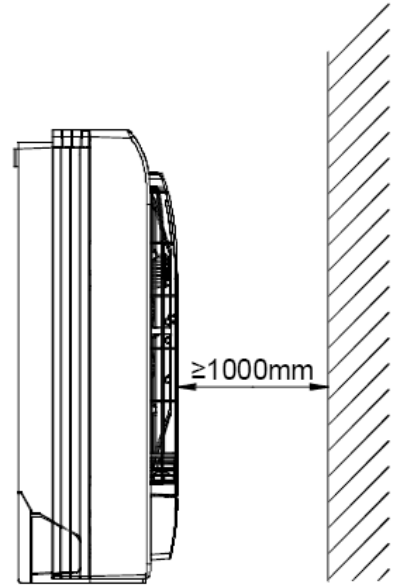
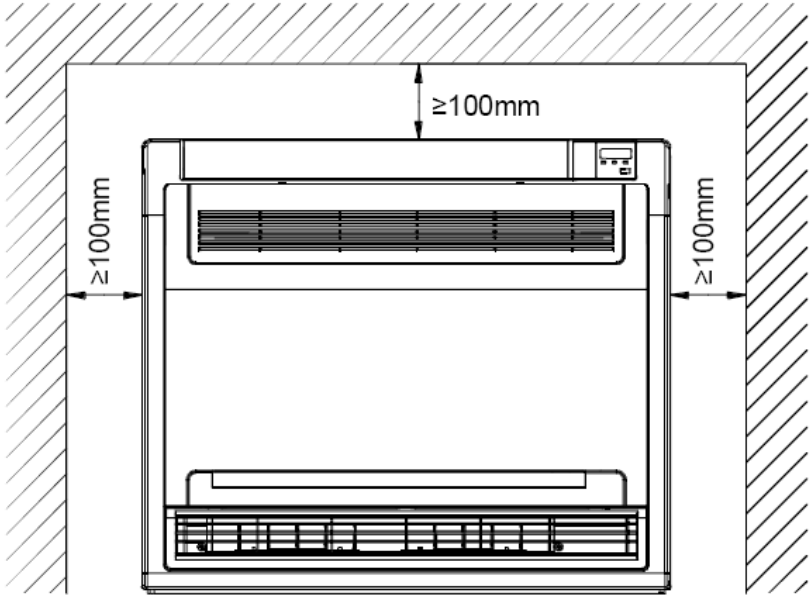

5. Wiring Diagram

5.2 MDCA2I-07HRDN1 MDCA2I-09HRDN1 MDCA2I-12HRDN1 MDCA2I-18HRDN1

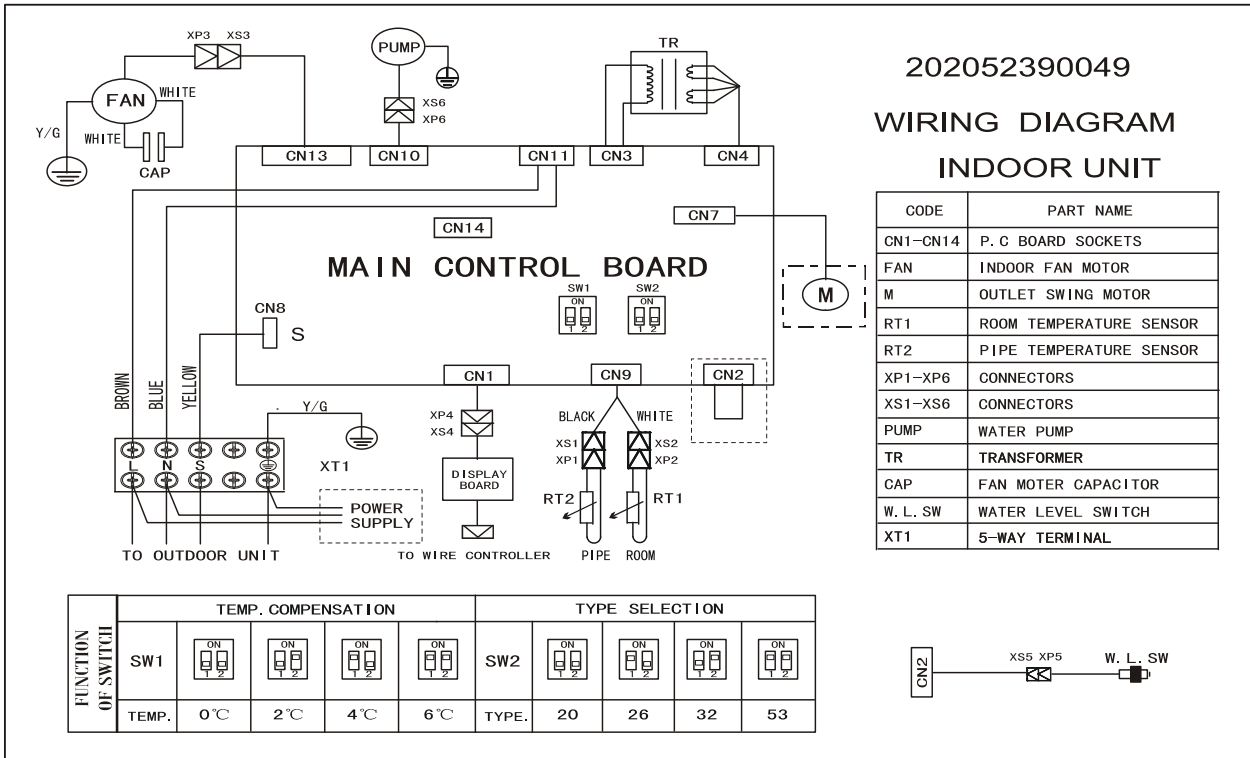

5.4 MDFF-07HRDN1 MDFF-09HRDN1 MDFF-12HRDN1 MDFF-18HRDN1

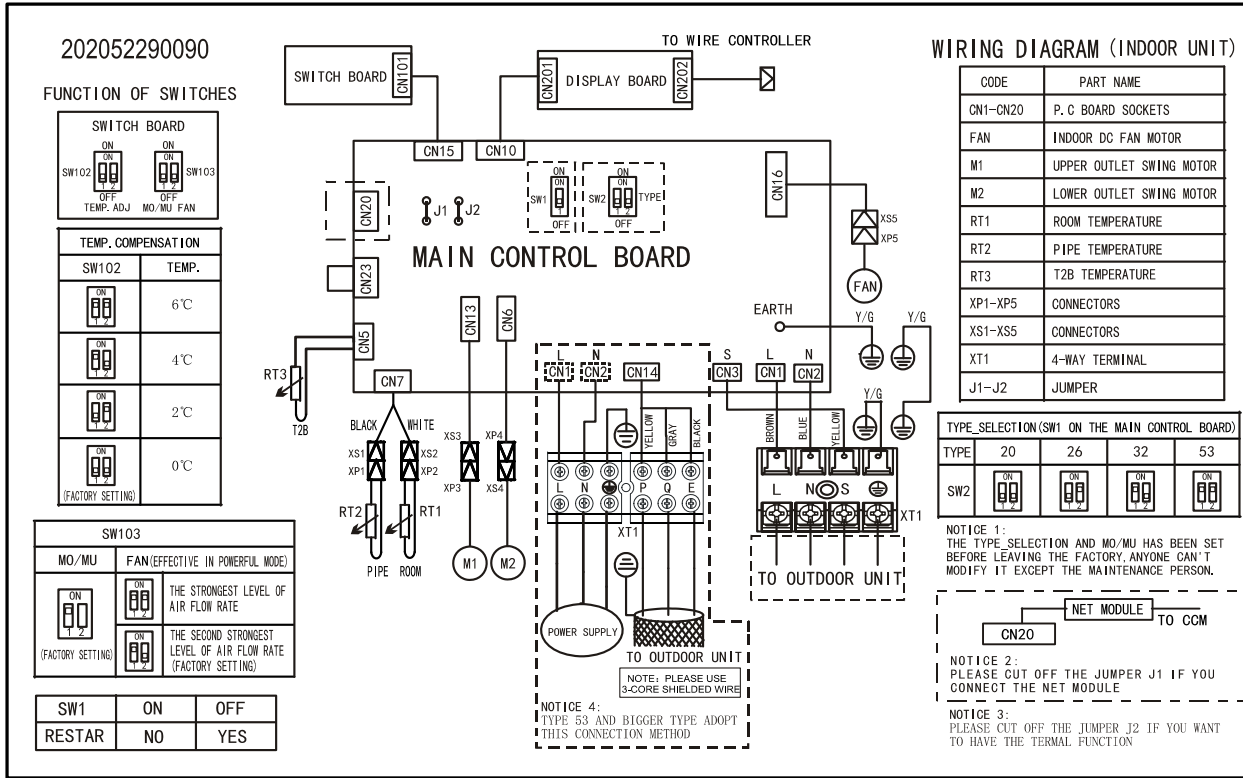

5.5 MDTBI-07HWDN1 , MDTBI-09HWDN1 , MDTBI-12HWDN1 , MDTBI-18HWDN1

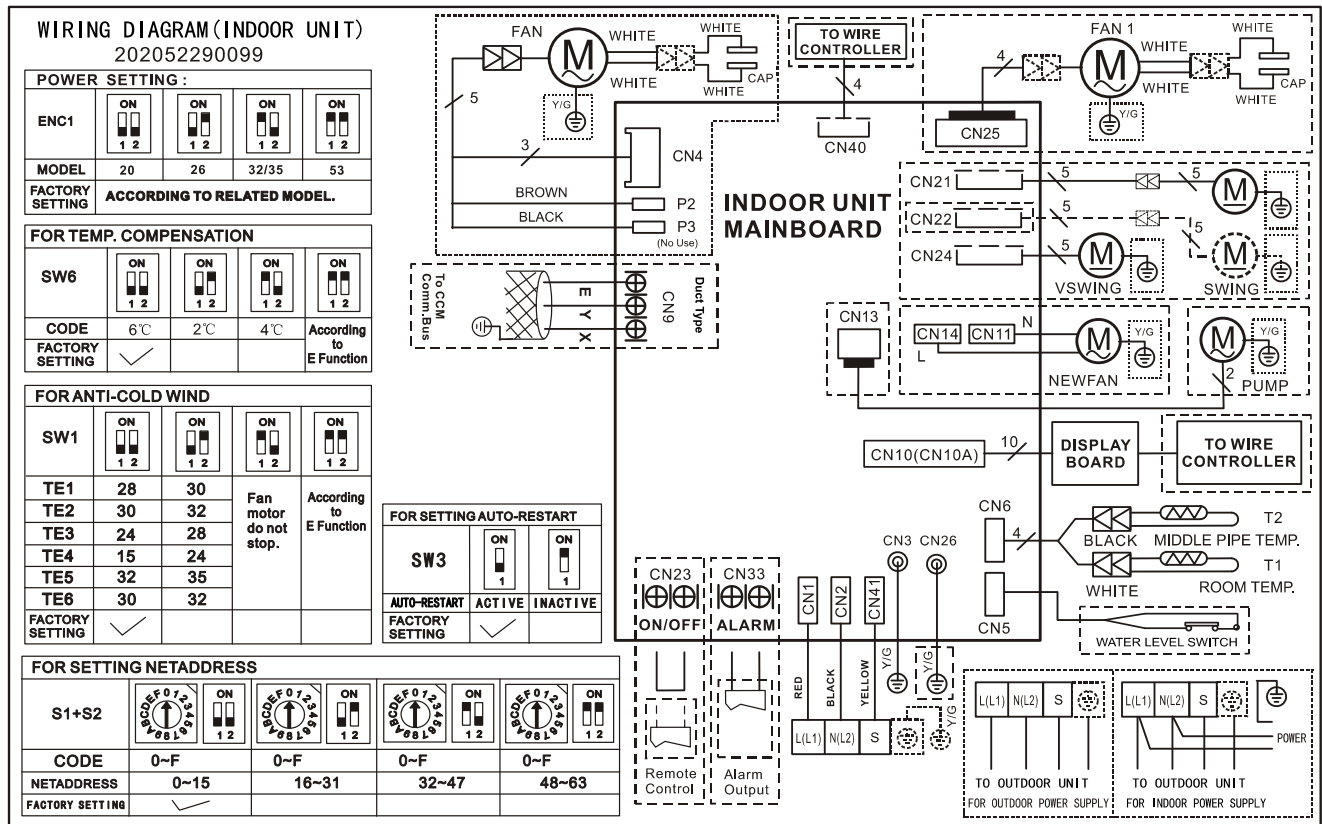

6. Operation temperature range

Mode \ Temperature	Cooling operation	Heating operation	Drying operation
Room temperature	$\geq 17^{\circ}\text{C}$	$\leq 30^{\circ}\text{C}$	$\geq 17^{\circ}\text{C}$
Outdoor temperature	$0^{\circ}\text{C} \sim 50^{\circ}\text{C}$	$-15^{\circ}\text{C} \sim 24^{\circ}\text{C}$	$0^{\circ}\text{C} \sim 50^{\circ}\text{C}$

CAUTION:

1. If the air conditioner is used beyond the above conditions, certain safety protection features may come into operation and cause the unit to operate abnormally.
2. The room relative humidity should be less than 80%. If the air conditioner operates beyond this figure, the surface of the air conditioner may attract condensation. Please set the vertical air flow louver to its maximum angle (vertically to the floor), and set HIGH fan mode.
3. The optimum performance will be achieved during this operating temperature zone.

7. Electronic function

7.3 Abbreviation

T1: Indoor room temperature

T2: Indoor evaporator temperature

TS: Setting temperature through the remote controller

7.2 Icon explanation on indoor display board

7.2.1 Four-way cassette (compact)

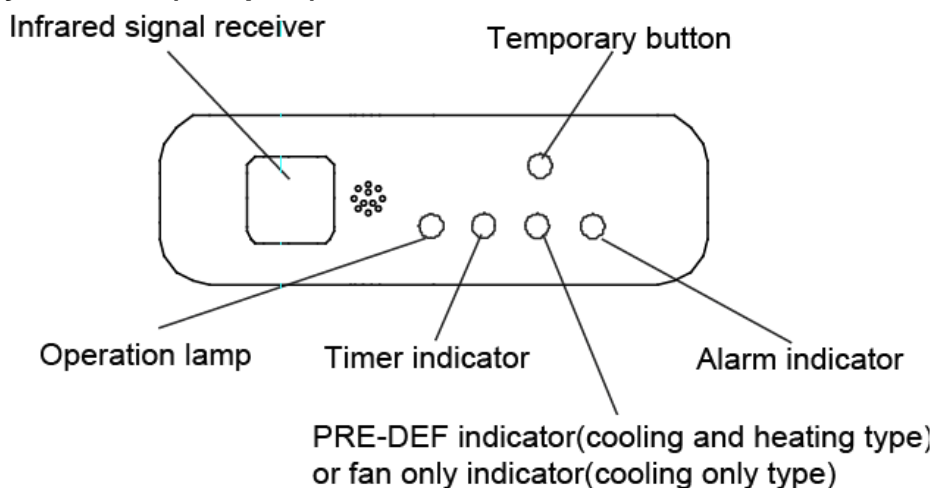

7.2.3 Console

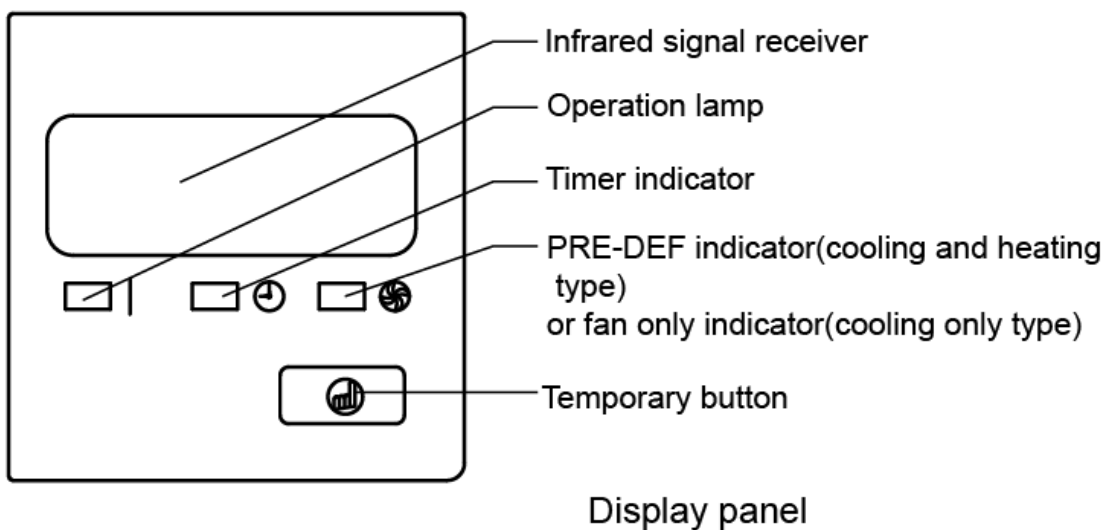

7.2.4 A5 Duct

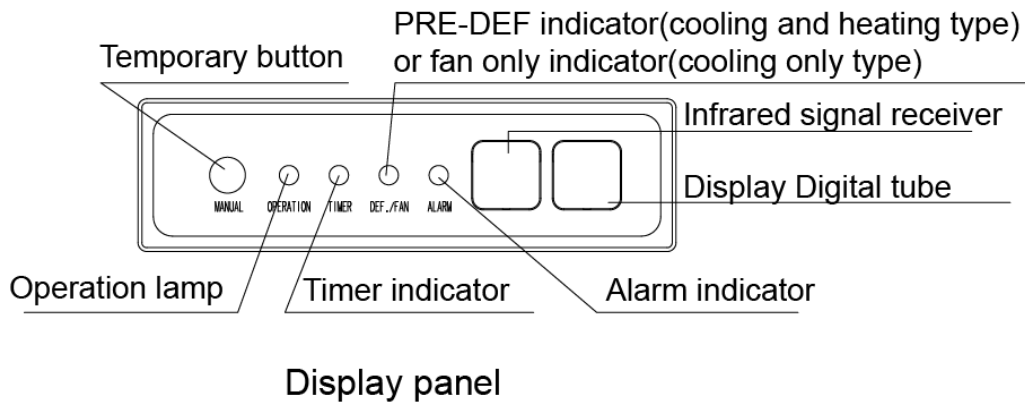

7.3 Main Protection

7.3.1 Sensor protection at open circuit and breaking disconnection.

7.3.2 The malfunction of correspondence in CMOS chip with EEPROM indication.

---- When the CMOS chip and EEPROM can't communicate during the time of using EEPROM to select parameter, the LED shows information of the malfunction (when use jump to select parameter, it doesn't have this function). After the showing, the unit can't go right to work except turning off.

7.3.3 Inverter module Protection (Only for console and A5 duct)

---- If inverter module protection happened, indoor unit gives an alarm. Voltage protection function doesn't action.

7.3.4 Indoor fan delayed open function (Only for console and A5 duct)

----When system starts up, the louver will be active immediately and the indoor fan will open 10s later..

----If the system runs in heating mode, the anti-cold wind function has priority.

7.4 Operation Modes and Functions

7.4.1 Fan-only mode

- (1) Outdoor fan and compressor stop.
- (2) Indoor fan can be set to high/med/low/auto.
- (3) The louver operates same as in cooling mode.
- (4) Auto fan in fan-only mode acts as follow:

For Console, Ceiling& floor and A5 Duct:

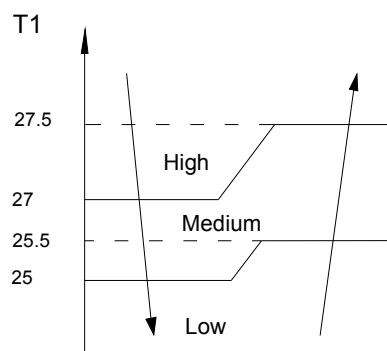

When $T1-24 \leq 27^\circ\text{C}$, transfer high to medium speed,
 When $T1 \leq 25^\circ\text{C}$, transfer medium speed to low.
 When $T1 > 25.5^\circ\text{C}$, transfer low to medium speed,
 When $T1 > 27.5^\circ\text{C}$, transfer medium speed to high.

For the other types:

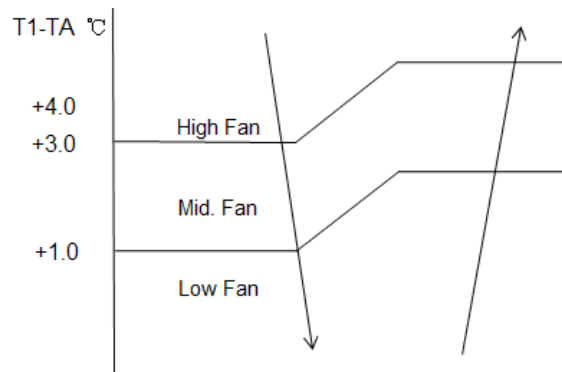

When $T1-TA \leq 3^\circ\text{C}$, transfer high to medium speed,
 When $T1-TA \leq 1^\circ\text{C}$, transfer medium speed to low.
 When $T1-TA > 1^\circ\text{C}$, transfer low to medium speed,
 When $T1-TA > 4^\circ\text{C}$, transfer medium speed to high.

For Four-way cassette (compact): $TA=23$

For New four-way cassette (compact)&A5 Duct: $TA=24$

(5) PTC function and sleep mode are invalid.

7.4.2 Cooling mode

(1) Indoor fan keeps running, fan speed can be set in high/mid/low/ Auto by using a remote controller:

(2) Auto fan in cooling mode acts as follow:

For Console:

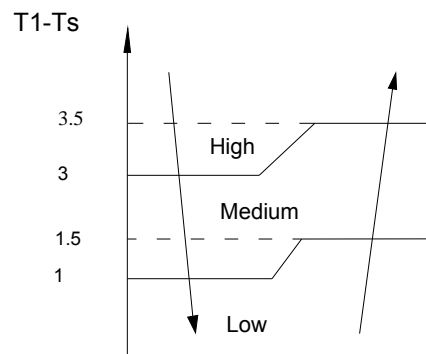

For Ceiling & floor & A5 duct:

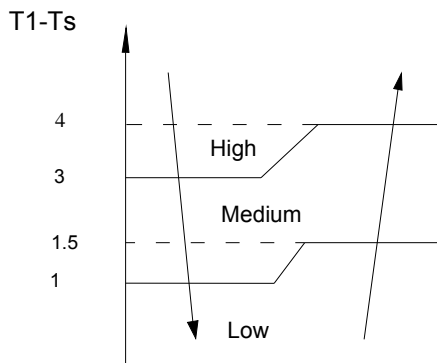

For the other types:

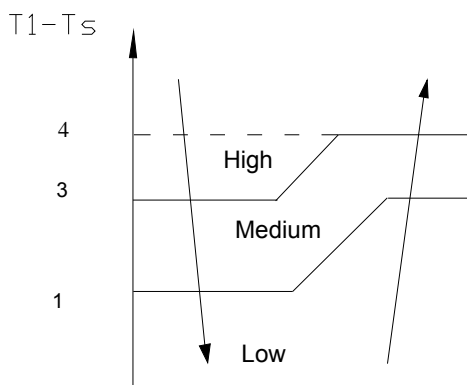

(3) Anti-freezing control to indoor evaporator in cooling mode

	Evaporator Temp.	Compressor
Console, ceiling & floor, A5 duct	$T_2 \leq 4^\circ\text{C}$	Off
	$T_2 > 8^\circ\text{C}$	On
The other types	$T_2 \leq 3^\circ\text{C}$	Off (After 3 minutes)
	$T_2 > 7^\circ\text{C}$	On

(4) PTC function is invalid and sleep mode can be set by using a remote controller.

7.4.3 Dehumidifying mode

- (1) Indoor fan speed is fixed in low speed (for console, it is fixed in breeze) and can't be changed.
- (2) In dehumidifying mode, the anti-freezing function of the indoor heat exchanger is the same as that of cooling mode.
- (3) Low indoor room temperature protection

In dehumidifying mode, if room temperature is lower than 10°C , the indoor fan will stop and not resume until room temperature exceeds 12°C .

7.4.4 Heating mode

(1) Indoor Fan actions in heating mode

Indoor Fan can be set at HIGH/MID/LOW/AUTO by using a remote controller, but Anti-cold wind function prevails.

Anti-cold wind control function in heating mode:

For console, ceiling & floor and A5 duct:

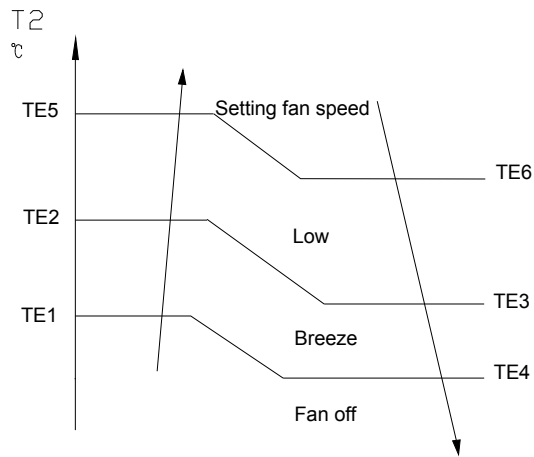

For the other types:

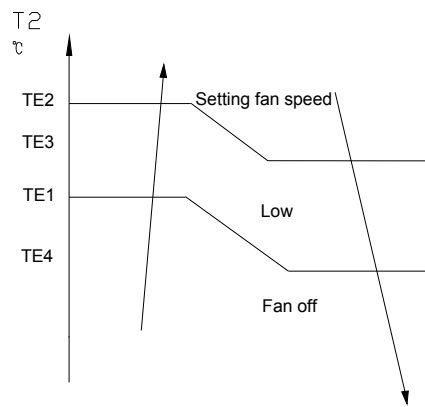

(2) Auto wind in heating mode
For Console:

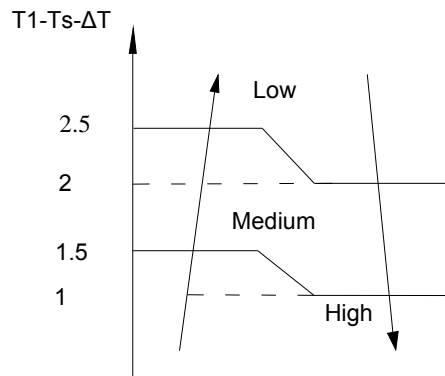

For Ceiling & floor and A5 duct:

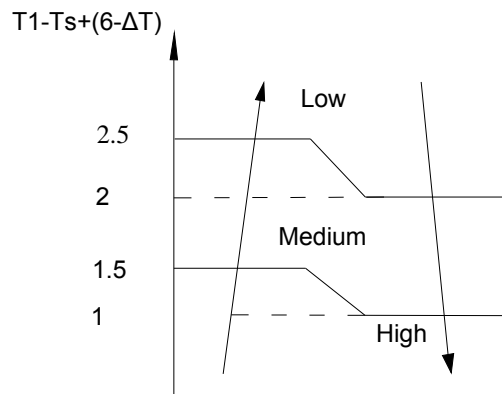

For the other types

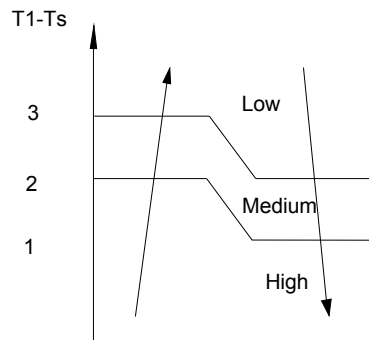

(3) Indoor evaporator high-temperature protection in heating mode
For Ceiling & floor and A5 duct:

$T_2 > 63^\circ\text{C}$, the compressor will stop and restart when $T_2 < 48^\circ\text{C}$.

For the other types

$T_2 > 60^\circ\text{C}$, the compressor will stop and restart when $T_2 < 48^\circ\text{C}$.

7.4.5 Prevent Over-Heating(except for old four-way cassette (compact))

For console and ceiling & floor: In heating mode, when the indoor unit has no capacity requirement due to indoor room temperature increased, the Indoor fan will run in breeze. (Anti-cold wind function has the priority)

For new four-way cassette (compact)&A5 Duct: In heating mode, when the indoor unit has no capacity requirement due to indoor room temperature increased, if outdoor fan and compressor stop, the Indoor fan will run in setting fan speed, otherwise, the Indoor fan will run in low. (Anti-cold wind function has the priority)

7.4.6 Defrosting

Defrosting operation (Available for heating only).

Defrosting Actions:

- a. Indoor fan switches off, anti-cold wind function is valid.
- b. After defrosting ends, indoor fan runs according to anti-cold wind function in heating mode.

7.4.7 Auto-mode

This mode can be chosen by remote controller and the setting temperature can be changed between $17\sim 30^\circ\text{C}$.

In auto mode, the machine will choose cooling, heating or fan-only mode according to the difference between T1 and TS.

$T_1 - T_S$	Running mode
$T_1 - T_S > 2^\circ\text{C}$	Cooling
$-1 < T_1 - T_S \leq 2^\circ\text{C}$	Fan-only
$T_1 - T_S \leq -1^\circ\text{C}$	Heating

Indoor fan will run in auto fan of the relevant mode.

The louver operates the same as in relevant mode.

If the machine switches mode between heating and cooling, the compressor will keep stopping for 15 minutes and then rechoose mode according to T1-TS.

If the setting temperature is modified, the machine will rechoose running function.

7.4.8 Forced operation function

(1) Enter forced operation function:

Pressing the touch button once, the machine will transfer into forced auto mode, if pressing the button once again, the machine will turn into forced cooling mode, the third pressing will stop the unit, and the fourth pressing is the start of the cycle of forced auto mode, forced cooling mode and stop. Refer the following chart:

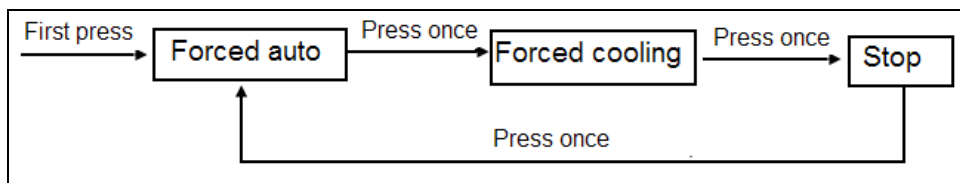

(2) In forced operation mode, all general protections and remote control are valid.

(3) Operation rules:

Forced cooling mode:

The indoor fan will work in low speed (For console, the indoor fan will work in breeze speed), compressor and outdoor fan open unconditionally, after 30mins, the unit will transfer into forced auto mode. All the protections are valid during forced cooling mode

When there's one indoor unit running in forced cooling, it is the master forced cooling unit. Other indoor units will run at forced cooling mode too and they will be the slave forced cooling units. The slave forced cooling units can not quit forced cooling mode until the master forced cooling unit quit.

The slave forced cooling units will not be controlled by other signals.

Forced auto mode:

The action of forced auto mode is the same as normal auto mode with 24°C setting temperature.

All the protections are valid during forced auto mode.

7.4.9 Timer Function

(1) Timing range is 24 hours, and the minimum resolution is 30 minutes.

(2) Timer on. After turning off, the machine will turn on automatically when reaching the setting time.

(3) Timer off. After turning on, the machine will turn off automatically when reaching the setting time.

(4) Timer on/off. After turning off, the machine will turn on automatically when reaching the setting "on" time, and then turn off automatically when reaching the setting "off" time.

(5) Timer off/on. After turning on, the machine will turn off automatically when reaching the setting "off" time, and then turn on automatically when reaching the setting "on" time.

(6) The setting time is relative time.

(7) The tolerance of timer is 1 minute per hour.

(8) The timer function will not change the AC current operation mode. Suppose AC is off now, it will not start up firstly after setting the “timer off” function. And when reaching the setting time, the timer LED will be off and the AC running mode has not been changed.

7.4.10 Sleep mode

(1) Operation time in sleep mode is 7 hours. After 7 hours the AC quits this mode and turns off.

(2) It is available at cooling, heating or auto mode.

(3) Operation process in sleep mode is as follow:

After pressing ECONOMIC or SLEEP button on controller, the machine will turn into sleep mode.

When cooling, the setting temperature rises 1°C (be lower than 30°C) every one hour, 2 hours later the setting temperature stops rising and indoor fan is fixed as low speed.

When heating, the setting temperature decreases 1°C (be higher than 17°C) every one hour, 2 hours later the setting temperature stops decreasing and indoor fan is fixed as low speed. (Anti-cold wind function has the priority)

When Auto, the sleep mode running function operates in accordance with selected running mode by auto mode.

(4) When user uses timer off function in sleep mode (or sleep function in timer off mode), if the timing is less than 7 hours, sleep function will be cancelled when reaching the setting time. If the timing is more than 7 hours, the machine will not stop until reaches the setting time in sleep mode. (Only for Console)

(5) For new four-way cassette (compact), when sleep function is cancelled, the indoor unit will not stop, for the other types, the indoor unit will stop.

7.4.11 Auto-Restart function

The indoor unit is equipped with auto-restart function, which is carried out through an auto-restart module. In case of a sudden power failure, the module memorizes the setting conditions before the power failure. The unit will resume the previous operation setting (not including Swing function) automatically after 3 minutes when power returns.

7.4.12 Mode conflict

The indoor units can not work cooling mode and heating at same time.

Heating mode has a priority.

(1) Definition

	Cooling mode	Heating Mode	Fan	Off
Cooling mode	No	Yes	No	No
Heating Mode	Yes	No	Yes	No
Fan	No	Yes	No	No
Off	No	No	No	No

No: No mode conflict;

Yes: Mode conflict

(2) Unit action

- In case of one Indoor unit working in cooling mode or fan mode, and another indoor unit is set to heating mode, the indoor unit working in cooling mode or fan mode will change to off. The outdoor unit will change to heating mode after compressor stop 3 minutes. .
- In case of one Indoor unit working in heating mode, and another indoor unit is set to cooling mode or fan mode, the indoor unit setting to cooling mode or fan mode will change to stand by. The outdoor unit will continue working in heating mode.

If heating mode stops (not including the indoor unit in heating mode reaching the set temperature), 3 minutes after the outdoor unit restarts and works in cooling mode or fan mode.