

Air to water heat pumps

MHZ “B” 011.1 ÷ 038.2

Cooling capacity from 40 to 140 kW

Heating capacity from 45 to 170 kW

50Hz – Refrigerant: HFC 407C

Scroll Compressors



Introduction

Purpose of the manual

The manual allows the installer and the operator to perform correctly all the operations referred to the installation and maintenance of the chiller without provoking any damages to the unit or to the qualified personnel.

Therefore the manual is a great help for the qualified personnel that have to arrange the equipment to provide the correct installation in accordance with local codes and regulation.

Inspection

When the equipment is received, all items on the bill of lading should be carefully checked to insure a complete shipment. All units should be carefully checked and all shipping damage should be reported to the carrier. The unit serial plate should be checked before unloading the unit to be sure that it agrees with the power supply available. Physical damage to unit after acceptance is not McQuay responsibility.

Responsibilities

McQuay Italia declines all present and future responsibilities referred to injuries to people and damage to things and unit, coming from operators negligence, the unrespected installation/maintenance data carrier in this manual, the lacking of the current regulations respect referred to the safety of the equipment and the qualified personnel.

Servicing and maintenance

Servicing and maintenance of these unit must carried out by experienced personnel with specifying training in refrigeration. Repeated check the safety devices and continous cycling of control components must be analyzed and corrected before being reset.

The simple design of the refrigeration circuit totally eliminates potential problems during normall unit operation. No maintenance work is needed on the refrigeration circuit as long as the unit is operating normally.

Characteristics

General description

McQuay International introduces their newest air to water heat pumps MHZ equipped with scroll compressors and electronic control system. McQuay have once again succeeded in developing a high quality product with extraordinary performance which is able to satisfy HVAC applications.

McQuay units are completely factory assembled, piped, wired and charged with refrigerant and shipped ready for the installation.

Each unit consists of scroll compressors, condenser coils with independent subcooler circuits, multiple propeller type direct drive condenser fans with independent fan motors, heavy-gauge weatherproof casing and weatherproof electrical control centre containing all necessary and operating controls and motor starting equipment.

MHZ units are high thermodynamic engineering products, studied with high accuracy in balancing compressors, condensers and evaporators in order to offer high performances and wide safety margins. The choose of the materials and the equipments adopted for the products has been made without any compromises, taking care of quality and long life purposes. The products meet ISO 9001 requirements, an assurance, beyond any doubts, of the high producing standards followed by McQuay.

Electrical data MHZ “B”

Unit size	011.1	013.1	017.1	020.1	022.2	025.2	029.2	033.2	036.2	038.2	
Standard voltage (1)	400 V - 3f - 50 Hz + NEUTRAL										
Nominal unit current (2)	A	32,3	37,8	45,4	54,8	64,1	75,9	83,9	93,5	99,4	109,8
Max compressor current (3)	A	29,3	35,4	44,4	54,6	61,0	74,4	83,8	95,2	98,0	109,6
Fans current	A	5,4	5,4	5,4	5,4	8,1	8,1	8,1	8,1	10,8	10,8
Max unit current (3)	A	34,7	40,8	49,8	60,0	69,1	82,5	91,9	103,3	108,8	120,4
Max unit inrush current (4)	A	151,6	154,3	203,1	207,8	186,2	195,0	246,0	253,2	260,4	268,2
Max unit current for wires sizing (5)	A	45,4	63,4	65,4	75,4	88,1	124,1	126,1	128,1	140,8	150,8

- Notes: (1) Allowed voltage tolerance $\pm 10\%$. Voltage unbalance between phases must be within $\pm 3\%$.
(2) Nominal current are based on: 12/7 °C entering/leaving evaporator water temperature and 35°C ambient temp.
(3) Maximum current are based on: 14/9 °C entering/leaving evaporator water temperature and 40°C ambient temp.
(4) Inrush current of biggest compressor + nominal absorbed current of the other compressors.
(5) Compressor FLA + fans current.

Operating limits summer conditions

MHZ	Entering evaporator water temperature		Leaving evap. water temp.(without glycol)		Evaporator water Δt		Ambient temperature	
	Min (°C)	Max (°C)	Min (°C)	Max (°C)	Min (°C)	Max (°C)	Min (°C)(*)	Max (°C)
011.1	8	20	4	15	4	8	15	42
013.1	8	20	4	15	4	8	15	42
017.1	8	20	4	15	4	8	14	42
020.1	8	20	4	15	4	8	12	40
022.2	8	20	4	15	4	8	15	42
025.2	8	20	4	15	4	8	13	40
029.2	8	15	4	10	4	8	12	40
033.2	8	15	4	10	4	8	10	40
036.2	8	20	4	15	4	8	15	42
038.2	8	20	4	15	4	8	15	40

(*) For ambient temperature down to -18°C low ambient kit is required (fan speed control)

Operating limits winter conditions

MHZ	Entering condenser water temperature		Leaving condenser water temperature		Condenser water Δt		Ambient temperature	
	Min (°C)	Max (°C)	Min (°C)	Max (°C)	Min (°C)	Max (°C)	Min (°C)	Max (°C)
011.1	25	45	28	50	4	8	-5	10
013.1	25	45	28	50	4	8	-5	10
017.1	25	45	28	50	4	8	-5	10
020.1	25	45	28	50	4	8	-5	10
022.2	25	45	28	50	4	8	-5	10
025.2	25	45	28	50	4	8	-5	10
029.2	25	45	28	50	4	8	-5	10
033.2	25	45	28	50	4	8	-5	10
036.2	25	45	28	50	4	8	-5	10
038.2	25	45	28	50	4	8	-5	10

Altitude correction factor

Elevation above sea level (m)	0	300	600	900	1200	1500	1800
Barometric pressure (mbar)	1013	977	942	908	875	843	812
Cooling cap. correction factor	1,000	0,991	0,981	0,972	0,962	0,953	0,943

Ethylene glycol and low ambient temperature correction factors

Air ambient temperature °C	-3	-8	-15	-23	-35
% of ethylene glycol correction factor	10	20	30	40	50
Cooling capacity correction factor	0,986	0,980	0,973	0,966	0,960
Flow rate correction factor	1,023	1,054	1,092	1,140	1,200
Water pressure drops correction factor	1,061	1,114	1,190	1,244	1,310

Low temperature operation performance factors

Ethylene glycol/water leaving temperature °C	2	0	-2	-6	-8
Cooling capacity correction factor	0,842	0,783	0,725	0,615	0,562
Power input compressors correction factor	0,950	0,934	0,918	0,870	0,845
Min % of ethylene glycol	10	20	20	30	30
Max air ambient temperature °C	40	40	38	34	32

Physical data MHZ “B” HFC 407C units

Unit size		011.1	013.1	017.1	020.1	022.2	
Cooling capacity (1)	kW	40,6	46,9	57,5	68,1	80,0	
Power input (1)	kW	14,1	17,2	22,4	27,8	29,9	
Heating capacity (2)	kW	46,0	54,0	67,4	80,0	91,4	
Power input (2)	kW	15,8	18,4	22,8	27,3	31,6	
Desuperheaters heating capacity (3)	kW	10,2	11,9	14,4	17,3	20,5	
Desuperheaters pressure drops (3)	kPa	12	16	13	18	16	
Scroll compressors							
No. of compressors / No of circuits		1 Tandem/1	1 Tandem/1	1 Tandem/1	1 Tandem/1	2 Tandem/2	
Oil charge	l	6,5	6,5	10,4	13,2	6,5+6,5	
No. of reduction steps		2	2	2	2	2	
Refrigerant charge	kg	6,5	7,0	8,0	10,0	12,5	
Plate heat exchangers							
Water volume	l	2,6	2,9	3,6	4,4	5,2	
Max. water pressure	bar	30	30	30	30	30	
Condenser fans							
No. of fans / Diameter		mm	2 / 630	2 / 630	2 / 630	2 / 630	3 / 630
Motor power / rotation regime	kW / rpm		0,6 / 880	0,6 / 880	0,6 / 880	0,6 / 880	0,6 / 880
Dimensions and weights							
Unit length	mm	2780	2780	2780	2780	3530	
Unit width	mm	1200	1200	1200	1200	1200	
Unit height	mm	1400	1400	1400	1400	1400	
Standard unit shipping weight	kg	462	586	620	684	754	
Unit with two pumps and tank weight	kg	512	676	710	784	854	

Unit size		025.2	029.2	033.2	036.2	038.2	
Cooling capacity (1)	kW	90,4	102,0	111,2	126,7	137,1	
Power input (1)	kW	36,8	42,1	48,6	50,5	55,8	
Heating capacity (2)	kW	106,5	121,1	132,7	152,7	166,7	
Power input (2)	kW	36,8	41,2	45,6	47,1	52,0	
Desuperheaters heating capacity (3)	kW	22,8	26,0	27,7	31,8	34,7	
Desuperheaters pressure drops (3)	kPa	18	17	22	22	23	
Scroll compressors							
No. of compressors / No of circuits		2 Tandem/2	2 Tandem/2	2 Tandem/2	2 Tandem/2	2 Tandem/2	
Oil charge	l	6,5+6,5	6,5+10,4	10,4+10,4	10,4+13,2	13,2+13,2	
No. of reduction steps		2	2	2	2	2	
Refrigerant charge	kg	15,0	18,5	20,5	25,5	25,5	
Plate heat exchange							
Water volume	l	5,8	6,8	7,6	9,7	9,7	
Max. water pressure	bar	30	30	30	30	30	
Condenser fans							
No. of fans / Diameter		mm	3 / 630	3 / 630	3 / 630	4 / 630	4 / 630
Motor power / rotation regime	kW / rpm		0,6 / 880	0,6 / 880	0,6 / 880	0,6 / 880	0,6 / 880
Dimensions and weights							
Unit length	mm	3530	3530	3530	4280	4280	
Unit width	mm	1200	1200	1200	1200	1200	
Unit height	mm	1400	1400	1400	1400	1400	
Standard unit shipping weight	kg	878	912	960	1140	1165	
Unit with two pumps and tank weight	kg	978	1012	1060	1240	1265	

- Notes:**
- (1) Nominal cooling capacity and power input are based on: 12/7 °C entering/leaving evaporator water temperature; 35°C ambient temperature.
 - (2) Nominal heating capacity and power input are based on: 40/45 °C entering/leaving condenser water temperature; 7°C ambient temperature, 90% H.R..
 - (3) Desuperheaters heating capacity and pressure drops are based on: 12/7°C entering/leaving evaporator water temperature; 40/45°C entering/leaving desuperheater water temperature; 35°C ambient temperature.

Safety measures

The unit must be suitably clamped to ground.

It is necessary to follow these cautions and warnings:

- The unit must be lifted only by using the proper tools able to support the weight of the unit.
- No admittance to unauthorized or unqualified personnel.
- No operation on electrical components is allowed without having switched off electricity supply.
- No operation on electrical components is allowed without using insulated platforms; no water or moisture should be present.
- All the operation on refrigerant circuit and pressurised components are to be performed by qualified personnel only.
- Compressor substitution or oil addition in this one must be performed by qualified personnel only.
- Sharp edges and coil surface are a potential injury hazard. Avoid contact with them.
- Disconnect all power to the unit while servicing condenser fan motors. Failure to do so may cause body injury.
- Avoid unrelated bodies into the water piping during the unit connection to the water system.
- It is necessary a mechanical filter for the piping connected to the exchangers entry.

Installation

Before any operation please check the instruction for use.

Warning

Installation and maintenance are to be performed only by qualified personnel who are familiar with local codes and regulations, and who are experienced with this type of equipment. Must be avoided the unit installation in places that could be considered dangerous for all the maintenance operations.

Transport

It is necessary to be sure of the stability of the unit during transportation. Therefore the unit is supplied with a transversal wooden beam placed on the unit base that must to be removed only after the final destination. In case the unit has to be moved again, a similar solution is necessary.

Handling and lifting

Care should be taken to avoid rough handling or shock due to the unit drop. Do not push or pull the unit from anything else than the base. When it is necessary to lift the unit suitable buttonholes are provided in unit base to arrange spreader bars and cables to prevent damage to the condenser coils or cabinet.

Location

The MHZ units are produced for outside installation on roofs, floors or below ground level on condition that the area is free from obstacles for the passage of the condensation air. The unit should be positioned on solid foundations and perfectly level; in the case of installation on roofs or floors, it may be advisable to arrange the use of suitable weight distribution beams. When the units are installed on the ground, a concrete base at least 250 mm wider and longer than the unit's footprint should be laid. Furthermore, this base should be sufficiently robust to withstand the unit weight mentioned in the technical data table. When the units are positioned in areas which are easily accessible by persons or animals, it is advisable to fit guards (option) to protect the condenser coil and the compressors.

Besides to obtain the best performance the location area it is necessary to follow the next precaution and advise:

- Avoid air flow recirculation.
- Take care that obstacle do not obstruct air flow.
- Breezy ambient is required to ensure the right air suction and delivery.
- To reduce noise and vibration a stiff floor is required.
- To avoid that condenser coils get dirty avoid dusty ambient.
- Chiller water must be quite clean and deprived of oil trace and rust particles. It is necessary a water filter on the entering water pipes.

Space requirements

The MHZ units are air-cooled, hence it is important to observe the minimum distances which guarantee the best ventilation of the condenser coils. Limitations of space reducing the air flow could cause significant reductions in cooling capacity, and increase in electricity consumption. The fans do not allow the use of ducts which have high flow resistance, hence it should be ensured that the output air cannot recycle itself inside the condenser coils. The units should be positioned such that there is sufficient distance between the coils and any obstacles to improve ventilation and also to facilitate inspection (fig. 1).

When two or more units are positioned side by side it is recommended that the condenser coils are at least 2500 mm distance from one another (fig. 2). Smaller distances could cause the recirculation of hot air. If the units are positioned in places surrounded by walls or obstacles of the same height as the units, the units should be at least 2000 mm from said obstacles (fig. 3). In the event the obstacles are higher than the units, the units should be at least 2500 mm from the obstacle (fig. 4). For other installation solutions, consult McQuay technicians.

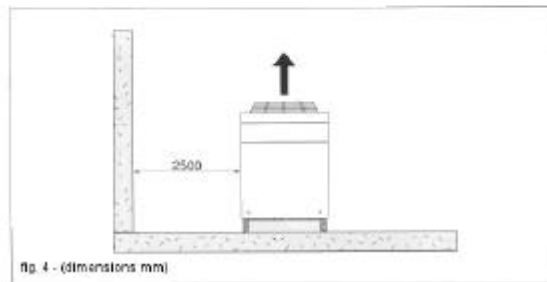
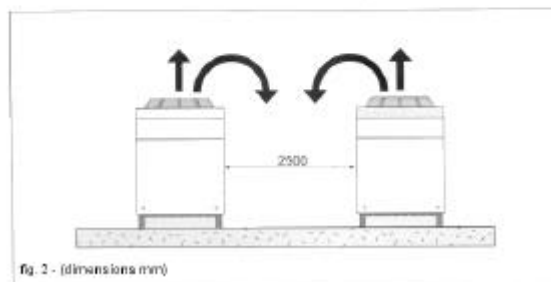
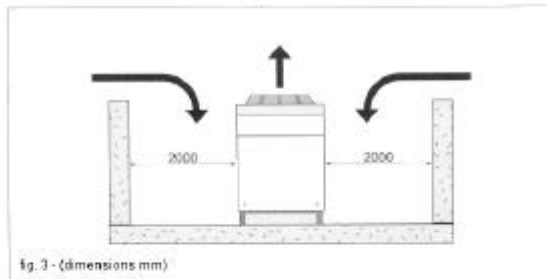
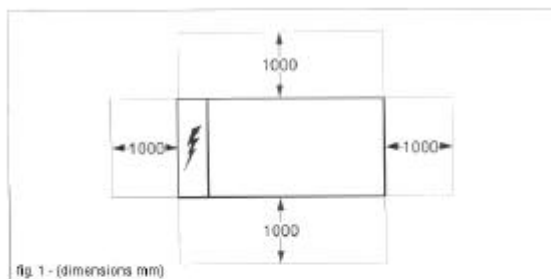

Acoustic protection

The low noise levels of the MHZ units means that they meet most of the most restrictive regulations. When the noise level must meet special requirements it will be necessary to pay the maximum attention to ensure the perfect insulation of the unit from the support base by applying appropriate vibration-dampening devices, applying vibration-dampening mounts on the water pipes and on the electrical connections (by the customer).

Water piping

- Shut-off valves should be provided at the unit so that normal servicing can be accomplished without draining the system.
- It is recommended that temperature and pressure indicators are installed at the heat exchangers inlet and outlet to aid the normal checking and servicing.
- It is recommended the installation of a wire mesh strainer at the pump suction to protect the pump and the exchangers from foreign matter.
- Before insulating the piping and filling the system, a preliminary leak check should be made.
- Vibration eliminators are recommended in all lines connected to the unit.
- Automatic flow control devices, although not furnished with the chiller as they are plant components, must be necessary be installed.

Evaporator and condenser water connections size are 2" for all MHZ units.

Freeze protection

If the unit is installed in an area where the ambient temperature can fall below 0°C, the heat exchanger, the piping and the inertial water tank can be damage by frost, despite the electric heater (standard supplied on the heat exchanger and the tank). In this case is recommended to add ethylene glycol with an adequate concentration (see

table on page 3) to protect the installation down to a temperature of 10 K below the lowest temperature likely to occur at the installation site (for example if the minimum forecast temperature is -13°C , must be considered a temperature of -23°C). If the unit is switched off and if the above-mentioned precautions are not followed, it is recommended to drain the hydraulic circuit.
 Damage due to freezing is not covered by the warranty.

Microprocessor MHZ 011.1 ÷ 020.1

Compact μ chiller is a versatile electronic controller as compact as a standard thermostat, specifically designed for the control of heat pumps.

Main functions

- Control of water temperature at evaporator inlet (inlet air)
- Time-based and/or temperature-based defrosting cycles
- Control of fan speed
- Full alarm management
- Can be linked up to serial line for supervisory telemaintenance control
- Can be linked up to an external terminal unit

Controlled devices

- Compressor
- Condensation fans
- Reverse cycle valve
- Water pump or supply fan (air-to-air)
- Antifreeze heaters
- Alarm signalling device

User interface

Display - The display consists of 3 digits, with the automatic display of the decimal point between -19.9 and $+19.9^{\circ}\text{C}$; outside this measurement range, the value is automatically displayed without decimal (although in its inside the machine is always operating by taking into account the decimal part). During the normal operation, the displayed value corresponds to the temperature being read by the probe B1, that is the evaporator water inlet temperature.

Status of the unit - The User is informed of the status of the unit by means of four LEDs on the display.

Meaning of LEDs in single-compressor units

LED	Flashing	Steady
Compressor	Request for compressor	Compressor actuated
Cooling	-	Cooling
Heating	-	Heating
X100	-	Visualized value x100

Parameters setting (see page 13)

Alarms and signalling

Any time an alarm condition is detected, the controller will prompt the following actions:

- the buzzer sounds
- the alarm relay energizes
- the temperature value blinks on display
- the alarm code appears on the LCD alternatively with the temperature value

After the alarms have been cleared either with automatic reset or by pressing the and buttons simultaneously for 5 seconds (for alarms with manual reset), the controller will restore normal operating conditions:

- the buzzer turns off
- the alarm relay disenergizes
- the temperature value blinks no longer
- the alarm code disappears from the LCD

If the alarm condition persists, the actions described above will be performed again.

Alarm table

Display	Tipo	comp.	pump	fan	resist.	valve	alarm
H1	high pressure	OFF	-	ON	-	-	ON
L1	low pressure	OFF	-	OFF	-	-	ON
t1	overload	OFF	OFF	OFF	-	-	ON
FL	flow detector	OFF	OFF	OFF	-	-	ON
E1,E2,E3	probe	OFF	OFF	OFF	-	-	ON
n1	automatic timer	-	-	-	-	-	-
EE	EEPROM run	-	-	-	-	-	-
EL	zero crossing	-	-	-	-	-	ON
d1	defrosting ON	-	-	-	-	-	-
r1	defrosting error	-	-	-	-	-	-
A1	antifreeze	OFF	-	OFF	-	-	ON
LO	low ambient temperature	-	-	-	-	-	ON
EU	low supply voltage	-	-	-	-	-	-
EO	high supply voltage	OFF	OFF	OFF	OFF	OFF	OFF
EP	EEPROM boot	OFF	OFF	OFF	OFF	OFF	OFF
Cn	discon. remote terminal	-	-	-	-	-	-
Ht	high temperature	-	-	-	-	-	ON

Electrical features

Power supply	
Voltage supply range	24V -15%...+10% 50/60 Hz (20,4V~ 26,4 Vac)
Maximum power absorbed by the device	3 W
Characteristics of the fuse (obligatory) to be inserted in series to the unit power supply	315mAT
Power driving	
Below, as "Group A" is defined the grouping of the following outputs	valve, pump, compressor, resistance
Max. current for each power connector	2 A
Relay output current (each relay, resistive load)	2A 250 V~
Relay output current (maximum 1 relay, resistive load)	3A 250 V~
Switching maximum number (each relay)	70000
Switching maximum number (each relay)	10 s

Microprocessor MHZ 022.2 ÷ 038.2

"µchiller" is based on two integrated systems (the 'Base' section including controller, inputs and outputs, and the 'terminal' section with User Interface functions). The Base and Terminal components can be enhanced by adding optional boards allowing further auxiliary functions.

Main board (single tandem)

The main board represents the core of the system, where the signals coming from the probes are processed. The modular structure of "µchiller" allows to get great flexibility and high performance. The compressor board, for example, can be upgraded by adding a module for the regulation of the capacity-controlled routine of the compressor or for the activation of a second tandem.

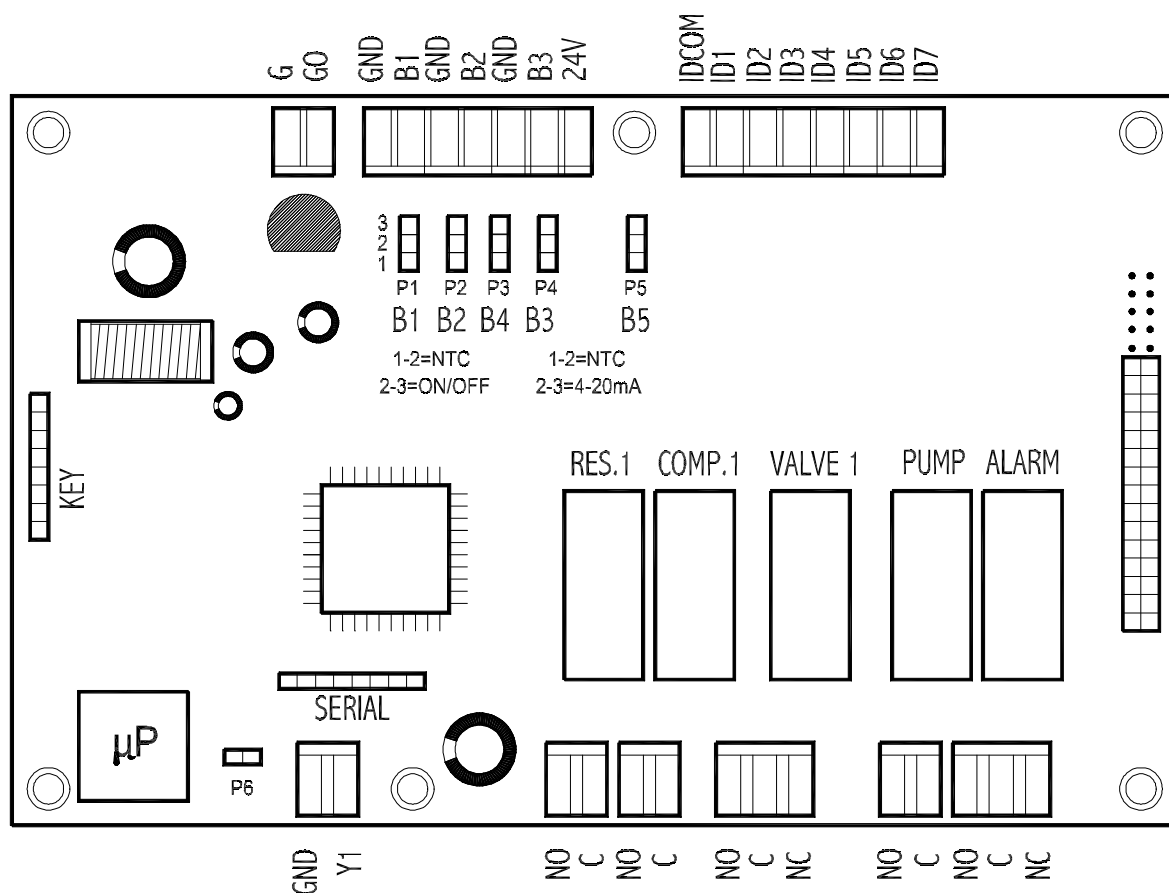

On this board you can locate clockwise the following connection “areas”:

- **G** and **G0** terminals for power source connection (24Vac)
- analog inputs (from **B1** to **B3**) for probe connection
- 24V terminal (with D.C.) for the supply of any pressure probes
- digital inputs (from **ID1** to **ID7**) for alarm connection
- jumper connector for expansion board connection
- digital relay outputs to manage any controlled device
- the **Y1 GND** analog output for the connection of the optional boards for the management of condensation fans (ON/OFF regulation mode or with continuous rotation speed variation)
- telephone connector for user terminal connection

Within the board itself you can also locate other four important areas:

- the **SERIAL** jumper for connection of an optional serial board for the interfacing to a supervisory and/or telemaintenance centralized system
- the **KEY** jumper for connection of an optional board (removable hardware key) for the immediate programming of all data
- **P1÷P5** pin-strips for the function mode selection of the analog inputs (B1÷B5)
- **P6** pin-strip relative to the Y1 analog output (to be normally left open, except in particular situations – see parameters F3 and F4).

The single compressor board has been designed so as to support two connected terminals, allowing therefore data access from two different points; it can also work without any connected terminal, ensuring this way a total safety to the data.

Second tandem board

It represents an expansion of the main board. The connection areas are the following (clockwise):

- analog inputs (**B4** and **B5**) for the probes connection (relative to the second circuit)
- 24V terminal (with D.C.) for the supply of any pressure probe
- digital inputs (from **ID8** to **ID11**) for safety connections (relative to the second circuit)
- digital relay outputs to manage any controlled device
- the **Y2 GND** analog output for the connection of the optional boards for the management of condensation fans (ON/OFF regulation mode or with continuous rotation speed variation)
- the flat cable for the connection to the single compressor main board
- **P1** pin-strip relative to the Y2 analog output (to be normally left open, except in particular situations – see parameters F3 and F4).

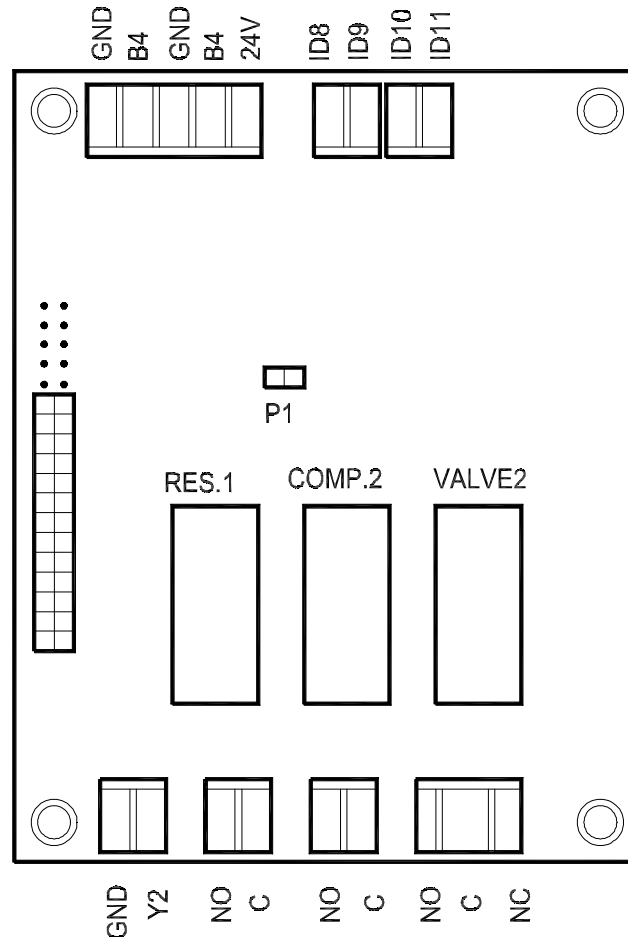

User Interface (Terminal)

The terminal allows the access to the data of the unit. On the terminal there are 5 LED indicators to indicate the status of the unit (Cooling/Heating), the status of the compressors (ON/OFF) and the timer for compressors/pump after 100 operating hours. An internal buzzer signals any maloperating in the unit.

Display - The display consists of 3 digits, with the automatic display of the decimal point between -19.9 and +19.9°C; outside this measurement range, the value is automatically displayed without decimal (although in its inside the machine is always operating by taking into account the decimal part). During the normal operation, the displayed value corresponds to the temperature being read by the probe B1, that is the evaporator water in-let temperature.

Status of the unit - The User is informed of the status of the unit by means of five LED indicators on the terminal display and two LED indicators (yellow and green) placed on the main board.

Meaning of LED indicators in single-compressor units

LED	Flashing	Steady
Tandem 1	Request for tandem 1	Tandem 1 actuated
Tandem 2	Request for tandem 2 Request for tandem 1 at 100%	Tandem 2 actuated Tandem 1 actuated at 100%
Cooling	-	Cooling
Heating	-	Heating
X100	-	Value X100

Yellow and green LED indicators on the main board - The yellow LED indicator informs the User of the correct operating of the unit. During normal operation it blinks every 1 second. In case of alarm condition it flashes more rapidly (about 2 times per second). In case of LED off the unit is not supplied. The green LED indicates that communication between unit and remote terminal is OK. In case of communication failure, the green LED turns off (usually due to a problem with the cable or to a not good contact between the cable and its relative female telephone connector on the main board or on the terminal).

Alarms and messages

Any time an alarm condition is detected, the controller will prompt the following actions:

- the buzzer sounds
- the alarm relay energizes
- the temperature value blinks on display
- the alarm code appears on the LCD alternatively with the temperature value.

After the alarms have been cleared either with automatic reset or by pressing the and keys simultaneously for 5s (for alarms with manual reset), the controller will restore normal operating conditions:

- the buzzer turns off
- the alarm relay disenergizes
- the temperature value blinks no longer
- the alarm code disappears from the LCD.

If the alarm condition persists, the actions described above will be performed again.

"µchiller" has 9 alarms detected by means of external digital contacts (24Vac); such external alarms are not detected with the unit in stand-by.

Alarm table

Type	Alarm	Reset	Message on display
High pressure circuit 1	open	manual	H1
Low pressure circuit 1	open	manual	L1
Tandem 1 overload	open	automatic	C1
Fan overload circuit 1	open	automatic	F1
Flow switch	open	manual	FL
High pressure circuit 2	open	manual	H2
Low pressure circuit 2	open	manual	L2
Tandem 2 overload	open	automatic	C2
Fan overload circuit 2	open	automatic	F2

Technical specifications

Power supply	
Power supply range	24V -15%...+10% 50/60 Hz (20,4V~ 26,4 Vac)
Minimum absorbed power	25 VA
Technical specifications	
Operating temperature	-10 ÷ 65°C
Operating umidity	90% U.R.
Index of protections	IP55

Buttons and relative messages on display Microprocessor MHZ 011.1÷038.2

Setting and displaying the set point and the main control parameters (DIRECT parameters).

The DIRECT parameters are set-points (Cooling and Heating) and main control parameters of the unit (Cooling and Heating differentials, 1 and 2 circuit water temperature, 1 and 2 circuit condensation temperature/pressure). If you press SEL for more than 5 seconds the display shows the code of the first parameter - the Cooling set-point - that can be modified. Pressing the ▲ and ▼ buttons allows to scroll all direct parameters. Press SEL again to display the required DIRECT parameter and modify its value (with the ▲ and ▼ buttons). Press PRG to store the modified parameters and exit the procedure, while the SEL button allows to return to the DIRECT parameters menu. On setting the parameters, the display will automatically flash after a few seconds if no buttons are pressed. If you do not press any button within 60 seconds after having entered this procedure, the unit will return to normal operation without storing the values of the modified parameters.

Setting and displaying USER parameters

These “working” parameters are protected by a password (**22**) to prevent any unauthorized access to the data. Press PRG for more than 5 seconds (the buzzer must be off) to enter the USER parameters (the unit “operating” parameters) menu and buttons ▲ and ▼ to select the password value, or, if the password is correct (22), press SEL to enter the USER parameter section. On setting the password, the display will automatically flash after a few seconds if no buttons are pressed. USER parameters selection: the display shows the code of the USER parameter that can be modified. Pressing the ▲ and ▼ buttons allows to scroll all USER parameters. Press SEL again to display the required USER parameter and modify its value (with the ▲ and ▼ buttons). Press PRG to store the modified parameters and exit the procedure, while the SEL button allows to return to the USER parameters menu.

Setting and displaying FACTORY-SET parameters

Factory-set parameters are configuration parameters and so they are protected by a password (**177**) to prevent any unauthorized access to the data. Press PRG and SEL simultaneously for more than 5 seconds to enter the factory-set parameters (unit configuration parameters) menu. This section is protected by a code (password), which is different from the USER one, to prevent any unauthorized access to the data. Setting the password: “00” flashes on the display. Pressing the ▲ and ▼ buttons will allow you to stop the blinking effect for a few seconds and select the password value (177); then press SEL to directly enter the factory-set parameters section. On setting the password, the display will automatically flash after a few seconds if no buttons are pressed. FACTORY-set parameters selection: the display shows the code of the factory-set parameter that can be modified. Pressing ▲ and ▼ allows to scroll all FACTORY-set parameters. Press SEL again to display the required FACTORY parameter and modify its value (with the ▲ and ▼ buttons). Press PRG to store the modified parameters and exit the procedure, while the SEL button allows to return to the FACTORY parameters menu.

Muting the BUZZER

Press the MUTE button to silence the buzzer.

Resetting ALARMS

Press ▲ and ▼ for more than 5 seconds to reset any alarm condition (manual reset). The relative LED light will turn off and the alarm relay will disenergize.

Forcing a DEFROSTING CYCLE

To force a defrosting cycle press the SEL and buttons ▲ for more than 5 seconds (if the temperature/pressure values of the outdoor exchanger are lower than the values set for the end of defrosting). In units with 2 Circuits the defrosting cycles will be simultaneous.

Enabling/disabling of COOLING operating mode

The cooling operating mode can be enabled/disabled by pressing the button ▲ for more than 5 s. It is not possible to directly pass from the heating to the cooling operating mode if before the heating mode is not unprimed: if the unit is actually operating in the heating mode, pressing the button will not swap the current mode.

Enabling/disabling of HEATING operating mode

The Heating operating mode can be enabled/disabled by pressing the button ▼ for more than 5 seconds. It is not possible to directly pass from the Cooling to the Heating operating mode: it is necessary to inhibit the Cooling mode.

Stand-by

To turn off the unit, deactivate the current operating mode (Cooling or Heating). When the µchiller is turned off, it keeps the the 4-way valves in the previous position for a period equal to pump OFF delay after the compressor is OFF.

Reset timers

When the display shows the operating hours of the compressor or of the pump, you can reset the timer by pressing the ▲ and ▼ buttons. In this case the unit will not prompt the relative compressors maintenance message.

Copying the KEY in the unit's eeprom

Press PRG and ▲ at µchiller start-up to copy the removable hardware key into the eeprom of the unit. When the procedure is over, the display will show 'CE' to confirm the operation.

Copying the unit's eeprom in the key

Press PRG and ▼ at µchiller start-up to copy the unit's eeprom into the removable hardware key. When the procedure is over, the display will show 'EC' to confirm the operation.

Setting DEFAULT PARAMETERS

Press the PRG button at µchiller start-up to set default parameters. Default parameters are based on FACTORY-set parameters and refer to DIRECT and USER parameters only. When the procedure is over, the display will show dF to confirm the operation.

Summary of the meaning of each button:

Button	Status of the unit	Effect after pressing the button
SEL	Normal operating condition (display shows the temperature of sensor B1) List of codes Displays values	after 5" DIRECT parameters appear displays value displays list of codes
PRG	Normal operating condition List of codes Displays values Buzzer sound	after 5" password for USER parameters stores parameters in eeprom stores parameters in eeprom silences the buzzer
▲	Normal operating condition List of codes Displays values	after 5" enables/inhibits Cooling mode displays the codes of the parameters increases value
▼	Normal operating condition List of codes Displays values	after 5" enables/inhibits Heating mode displays the codes of the parameters decreases value
PRG+SEL	Normal operating condition	after 5" password for FACTORY parameters
SEL+▲	Normal operating condition	after 5" forces a manual defrosting cycle
▲+▼	Normal operating condition Hour counter is shown	after 5" manual alarm reset hour counter zeroes down immediately
PRG	At start up	default parameters
PRG+▲	At start up	copies key on the unit's eeprom
PRG+▼	At start up	copies unit's eeprom on the key

Start up and shut down

Pre start-up

- With main switch Q10 open, check all electrical connections in control panel and starter to be sure they are tight and provide good electrical contact. Although connections are tightened at the factory, they may have loosened enough in shipment to cause a malfunction.
- Verify that the automatic circuit breaker Q9 is in OFF position.
- Check and inspect all water piping. Make sure flow direction is correct and piping is made to correct connection on evaporator and heat recovery exchanger.
- Check for inlet/outlet piping proper connections as indicated on the exchangers.
- Open all water flow valves to the heat recovery exchanger and evaporator.
- Check all pipings for leaks. Vent the air from the evaporator and heat recovery exchanger water circuit. The cooler circuits should contain clean and non corrosive water.
- Check pressure drop across evaporator and heat recovery exchanger, and see that water flow is correct for design flow rates and data.
- Check the actual unit line voltage to be sure it is the same you can read on the compressor nameplate within ±10% and that phase voltage unbalance does not exceed 3%.

- Verify that adequate power supply and capacity is available to handle load.

Start-up

Start-up must be performed by specialized personnel:

1. Open the compressor suction and discharge shut-off valves; always replace seal caps.
2. Open the manual liquid line shut-off valve.
3. Check to see that the automatic circuit breaker Q9 is in the OFF position.
4. Check to see that the main switch Q10 (unit ON/OFF switch) is in OFF position.
5. Verify crankcase heaters have operated at least 12 hours before start-up. Crankcase should be warm.
6. Start the auxiliary equipment for the installation by turning on the time clock, ambient thermostat and/or remote ON/OFF switch cooling and chilled water pump.
7. Check all the safety control.
8. Switch the main switch Q10 to ON.
9. Start the system by switching the unit circuit breakers Q9 to ON.

Emergency stop

A red switch is provided on control box, to allow the unit emergency stop. The unit must be restarted following this procedure:

1. Reset emergency stop switch Q11.
2. Repeat start-up procedure from beginning.

MHZ "B" Unit dimensions

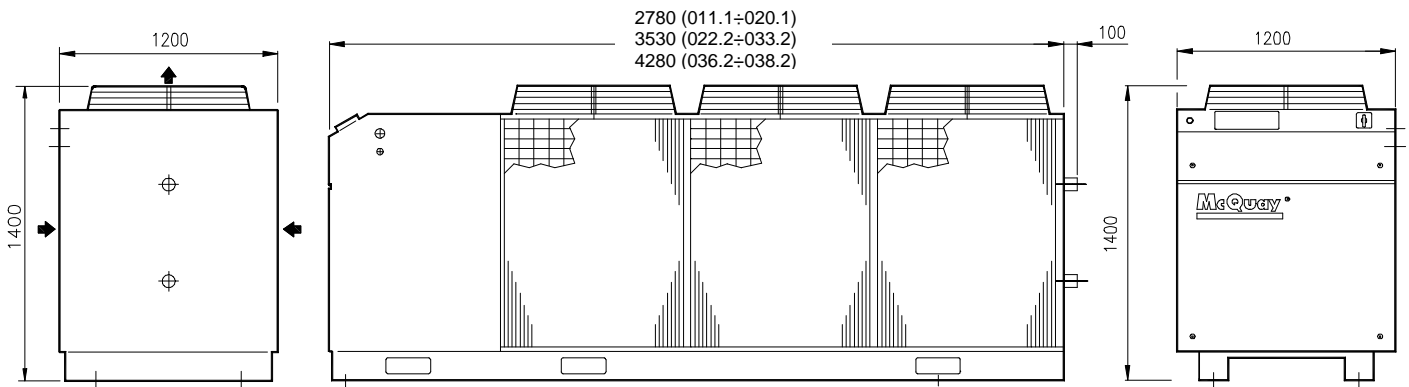

Fans Arrangement

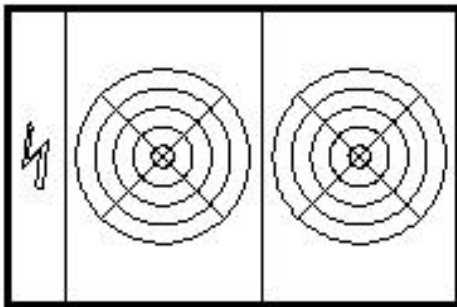

MHZ "B" 011.1 ÷ 020.1

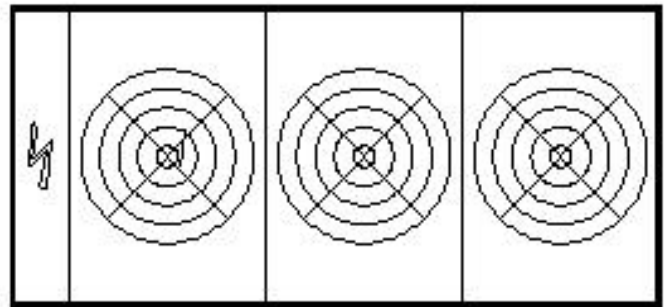

MHZ "B" 022.2 ÷ 033.2

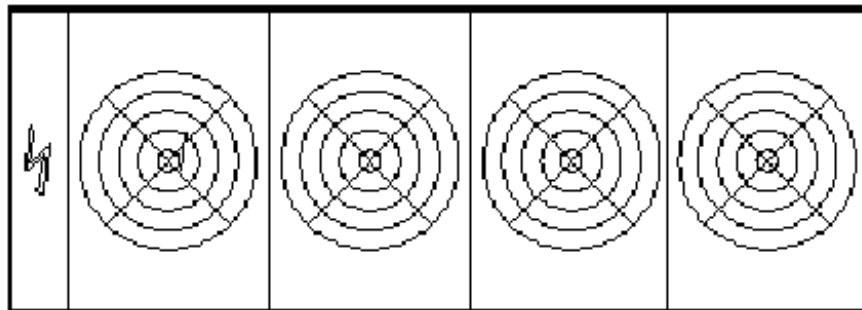

MHZ "B" 036.2 - 038.2

We reserve the right to make changes in design and construction at any time without notice, thus the cover picture is not binding.



McQuay Italia S.P.A.
S.S. Nettunense, km 12+300 – 00040 Cecchina (Roma) Italia – Tel. (06) 937311 – Fax (06) 9374014 – E-mail: mcquay@mcquayitalia.com