

Date: November 2004

Supersedes: 401B - 02/10 D

## Air to water heat pumps

**MHR 050.2÷110.2****Cooling capacity from 151 to 380 kW****Heating capacity from 186 to 372 kW****50 Hz - refrigerant: HCFC 22; HFC 407 C**

McQuay is participating in the Eurovent Certification Programme. Product are as listed in the Eurovent Directory of Certified Products and on the web site [www.eurovent-certification.com](http://www.eurovent-certification.com)



**McQuay**<sup>®</sup>  
Air Conditioning

# MHR - Air to water heat pumps

McQuay air to water heat pumps MHR equipped with scroll and reciprocating compressors are a new line of the proven range of air cooled units. They are manufactured by McQuay to satisfy the requirements of the consultants and the end user. McQuay MHR units are designed to minimise energy costs while maximising the refrigeration capacities. A wide range of accessories are available which can be utilised to engineer solutions for both the air conditioning and for industrial applications.

## Highly flexible design

The MHR units is available in 12 sizes covering a range from 151 to 380 kW nominal cooling capacity when equipped with special accessories they can operate with an external air temperature of -5°C and with coolant temperature between +15°C and -8°C. Many optional features can be added to fit all installation requirements.

## Low installation costs

The complete assembly of the units and function testing at the factory reduces the cost of installation on site. A rigid steel base distributes the weight of the unit to the support points and allows simple installation by an easy access to the lifting points. The units are designed with a single point three-phase mains connection for 400 Volt. A transformer, fitted as standard on the control panel, feeds the control system.

## Low maintenance costs

The microprocessor safety and control system allows the trouble shooting of any type of functional anomaly, enabling simpler, safer and timely intervention by the unit maintenance personnel. The oil heater in the sump on each compressor and a complete set of controls and safety devices protect the unit from abnormal operating conditions.

The design of the MHR unit, with two independent refrigerant circuits, increases the redundancy of the unit and allows maintenance while a part of the unit continues to function.

## Code requirements

Chiller rating: EN 12055.  
Pressure vessel approval: PED.  
Elect. & Safety Codes: IEC 204-1 CEI 44-5.  
Safety Codes: CEI-EN 60204-1.  
Quality Stds : ISO 9001 :2000.

## Factory testing

Each unit is pressure tested, vacuum tested, evacuated and charged with the refrigerant requested. It is then tested at the factory's test bench under the design conditions specified by the customer. Upon request, a second series of tests can be carried out witnessed by the customer. Before shipment, each unit is re-checked for pressure and refrigerant charge control.

# General characteristics

## Cabinet and structure

The cabinet is made of galvanised steel sheet and painted to provide a high resistance to corrosion. The unit base

frame has holes to lift the unit with ropes for an easy installation. The weight is uniformly distributed along the profiles of the base and this facilitates the arrangement of the unit's bases and the support structures. The electrical and control equipment is located inside cubicles which can be accessed by key locked doors complete with door interlocking on the power cabinet.

## Compressors

The compressors installed in the MHR units are of the semihermetic reciprocating type.

### Semi-hermetic reciprocating compressors

Consist of multiple cylinders with suction and discharge valves. The forced lubrication of the crankshaft bearings and of the big end bearings is achieved by using a gear pump which is independent of the compressor's direction of rotation. The crankshaft of each compressor is statically and dynamically balanced. In addition, each compressor is fitted with oil differential pressure switch. Each scroll or reciprocating compressor is charged with the necessary quantity of lubricant and supplied with the following accessories as standard: sump heater, electric motor protection module, discharge and suction shut-off valves (optional for reciprocating).

## Condenser / evaporator coils

The new MHR units are constructed with internally enhanced seamless copper tubes arranged in a staggered row pattern and mechanically expanded into McQuay lanced and rippled aluminium condenser fins with full fin collars. Each coil is provided with a drain pan. A drain nozzle is present for an easy drain connection.

## Fans

The fan are of the helical type with wing-profile blades to achieve a better performance. The direct coupling with the electrical motor eliminates any problems as regards the application of transmission devices and reduces the vibrations caused by the functioning. The motors are supplied as standard with IP54 protection (Insulation class F) and are of the three-phase type; they are protected against overloading and short circuits by circuit breakers located inside the electrical control panel. The fans operate in formed bell shaped orifices.

## Electrical control panel and control devices

The electrical components for both the power and the control are split into two sections on the main panel, accessed by individual key locked doors to prevent unauthorized entry. The panel is manufactured to ensure protection in all weather conditions (IP 54) and the doors are fitted with door-stays to prevent accidental closure. The power panel is fitted with a door interlocked mains isolator to prevent access while it is live. The electrical control panel complies with IEC204-1 safety norms.

**The power section includes:** contactors, fuses for compressors, fans circuit breakers and control circuit transformer. Additional space is provided for the installation of the various optional accessories provided to enhance the capabilities of the AG units.

**The control section includes:** the microprocessor regulator which carries out the following functions:

- access password to prevent unauthorised access
- water temperature control
- regulation of temperature set points
- start-up sequence delay device
- compressor functioning- fan on-off control
- antifreeze control
- antifreeze heater functioning
- general alarm
- differential pressure switch or pump failure alarm (opt.)

By means of automatic safety and protection devices the microprocessor controls the main components of the equipment such as: thermal protection of the electric motor windings, refrigerant and oil pressure monitoring. A microprocessor internal clock (optional) can be used to program the operating schedule of the chiller and the water circulating pumps in order to meet each specific building load profile precisely.

### Ambient condition

The MHR units can operate as standard with an external air temperature down to -5°C in winter condition. All units can function with an external air temperature of up to +42°C.

### Refrigerant circuit

The MHR units are equipped with a complete refrigerant circuit charge HCFC22. The circuit consists of insulated copper pipes on the suction line and is complete with suction shut-off valves (option for reciprocating), filter driers, moisture indicators, liquid sight glass, thermostatic expansion valves.

### LN Version

The MHR LN units are available only on summer operation and are supplied complete with: Sound proofing cabinets around the compressors, insulated with highly absorbent acoustic material. The cabinet frame is made of aluminium profiles ensuring proper sealing of the panels. Compressors are installed on rubber anti-vibration supports to avoid the transmission of vibrations to the frame. The fans running at lower RPM are controlled by an electronic regulator which provides continuous speed variation. This regulator maintains the functioning of the fans at reduced speed up to an external air temperature of +38°C. Above this temperature, in order to keep occasional functioning with a higher external air temperature, of up to +42°C, the regulator increases the fan RPM to be in line with the standard unit fan RPM. This system allows the continuous supply of the cooling load, even when the ambient temperature exceeds the limits envisaged for the LN version. In winter operation the LN is not working.

## Accessories and Options

**Compressor thermal overload relays** - Safety devices against compressor motor overloading in addition to the normal protection envisaged by the electrical windings.

**Phase monitor** - The phase monitor controls the voltage values on the supply line stopping the unit when the calibration threshold is reached ( $\pm 10\%$ ). This safety device is automatically reset.

**Ammeter and voltmeter** - Digital meters of unit drawn amperes and voltage values, installed on the electrical

control panel.

**Condenser power factor correction** - Installed on the electrical control panel to ensure it conforms to the plant rules. (McQuay advises maximum 0,9).

**Fan speed regulator** - This device allows the continuous variation of the fan speed, modifying the air flow according to the external temperature conditions down to -10°C (standard for the LN version).

**Condenser coil guards** - Metal protection guards fixed on all the external surface of the condenser coils.

**Compressor guards** - To prevent unauthorised access to the cooling unit components.

**Cu-Cu condensing coils** - To give better protection against corrosion by aggressive environments.

**Cu-Cu-Sn condensing coils** - To give better protection against corrosion in aggressive environments and by salty air.

**Alucoat condensing coils** - Fins are protected by a special epoxy paint with a high resistance to corrosion.

**Flow switch** - Supplied separately to be wired and installed on the evaporator water piping (by the customer).

**Suction shut-off valve** - Suction shut-off valve installed on the suction port (not available on MHRZ).

**Gauges** - Gauges to control high and low gas pressure and lubricant oil pressure (not available on MHRZ).

**Spreader bars** - Facilitate the lifting of the units keeping the ropes away from the unit's casing.

**Wooden box packing** - Self-supporting wooden box internally insulated and suitable for shipment by sea.

**Open Cage packing** - Protection with polythene and wooden cage for transport and protection before the installation.

**Rubber type antivibration mounts** - Supplied separately, these are positioned under the base of the unit during installation. Ideal to reduce the vibrations when the unit is floor mounted.

**Spring type antivibration mounts** - Supplied separately, these are positioned under the base of the unit during installation. Ideal for dampening vibrations for installation on roofs and metallic structures.

**TUV approval** - If required, the cooling units can be TUV tested and certified.

**Witness tests** - The units are normally tested at the test bench prior to the shipment. On request, a second test can be carried out, at customer's presence, in accordance with the procedures indicated on the test form.

## Selection Procedures

The procedure for selecting the cooling duty and the power absorbed by the compressors of the MHR units is indicated below.

1. The tables "Standard ratings" allow to determine the cooling capacity, power absorbed by the compressor motors and, with cooled water temperatures between +4°C and + 9°C, ambient air temperatures between +25°C and +42°C and leaving hot water temperatures between 40°C and 50°C.

2. Although the data can be interpolated, extrapolation is not permitted. For conditions other than those shown in the tables, contact McQuay.

3. The performance of the MHR units refers to 5°C of  $\Delta t$  of chilled water. The increase or reduction of the flow rate of chilled water produces a reduction and an increase in the cooling performance which is negligible. To ensure the correct functioning of the exchanger, it is advisable to

maintain the water's  $\Delta t$  within 3°C - 8°C.

4. The performance figures are based on Fouling factor of 0.044 m<sup>2</sup>°C/kW. In the event of different values, the correction coefficients indicated in Table 2 should be used.

5. The performance is influenced by air density. Table 3 gives the correction factors for the various altitudes above sea level.

6. The power absorbed values given in the standard performance tables refer to the compressors only. The current absorbed by the fans is given in the electrical characteristics table.

7. To obtain the flow resistance through the exchanger, use the diagrams on page 12.

8. The use of ethylene glycol to protect the evaporator and the hydraulic circuit from freezing when the external temperature is below 0°C when the unit is switched off, affects the unit's performance. Cooling capacity, coolant flow and pressure drop variations are in accordance with the correction coefficients given in Table 4. Ethylene glycol should be used in the cases when the MHR cooling unit has to cool the liquid at temperatures of less than +4°C for HCFC 22. To select a unit for cooling nonfreezing mixtures at temperatures of less than those shown in the table.

### Example of selection of an MHR unit

Data:

Cooling capacity required: 230 kW

Ambient air temperature: +35°C (summer)

Temperature of cooled water: from 12 to 7°C

Temperature of hot water: from 40 to 45°C

Ambient air temperature: +5°C (winter)

Refrigerant: HCFC22

Maximum sound level 80 dB(A) at 1 metre distance

Fouling factor: 0.132 m<sup>2</sup>°C/kW

Altitude above sea level: 600 m

Glycol content: none

1. The correction coefficient for fouling 0.132 m<sup>2</sup>°C/kW (Table 2) is 0.975.

2. The correction coefficient for installation at 600 m above sea level (Table 3) is 0.986.

3. The corrected cooling capacity is 230 kW/0.975/0.986 = 239.2 kW.

4. The cooling unit to satisfy this capacity is MHR 070.2 ST 022. This unit will have the following operating data:

Cooling capacity:

251.0 kW x 0.975 x 0.986 = 241,3 kW

Power absorbed by compressors:

79.3 kW x 0.986 x 1.009 = 79.3 kW.

Chilled water flow rate: 238,6 kW/4.186/(12-7) = 11.45 l/s.

Heating capacity:

253,2 kW x 0.975 x 0.979 = 241,7 kW.

Flow rate of recovered hot water:

307.9 kW/4.186 x (45-40) = 11,54 l/s.

Pressure drop indicated by the diagram on page 12 with a cooled water flow of 11,45 l/s on the straight line corresponding to the unit MHR 070.2 we find a pressure drop of 51 kPa with a flow of 11,54 l/s has a pressure drop of 52 kPa.

### Water content in cooling circuits

The cooled water distribution circuits should have a minimum water content to avoid excessive intermittent operation of the compressors. In fact, each time the compressor starts up, an excessive quantity of oil goes from the compressor's sump and simultaneously there is a rise in the temperature of the compressor motor's stator due to the inrush current during the start-up. To prevent

damage to the compressors, McQuay has envisaged the application of a device to limit frequent stops and restarts. During the span of one hour there will be no more than 6 starts of the compressor. The plant side should therefore ensure that the overall water content allows a more constant functioning of the unit and consequently greater environmental comfort. The minimum installation water content envisaged should be calculated with a certain approximation using this formula:

$$(1) Q = (P \times p)/25$$

where:

Q = minimum content of the plant expressed in litres.

P = cooling capacity of the plant expressed in W

p = minimum unloading capacity percentage

A plant with a 230 kW cooling capacity in which the cooling unit MHR 070.2 ST 022 equipped with two compressors is applied, should have a minimum content of water calculated on the basis of the minimum cooling capacity, which for this type of equipment is 25% of the nominal capacity.

$$Q = (230000 \times 0.25)/25 = 2300 \text{ l}$$

For a more accurate determination of the quantity of water, it is advisable to contact the designer of the plant. When the sum of the water content of the evaporator, the pipes of the hydraulic circuit and the terminals (coils, exchangers, etc.) is lower than the value obtained.

**Table 1 – Operating limits**

	°C	Cooling		Heating	
		min	max	min	max
Water inlet temp. R22	°C	-5	20	25	45
Water inlet temp. R407C	°C	-5	20	25	40
Water outlet temp. R22	°C	-8	15	28	50
Water outlet temp. R407C	°C	-8	15	28	45
Water $\Delta t$	°C	4	6	4	6
Ambient temperature	°C	-18	42	-5	15

**Table 2 – Fouling factor**

Fouling factor m <sup>2</sup> °C/kW	Cooling capacity factor	Power input correction factor
0,044	1,000	1,000
0,132	0,975	0,986
0,308	0,919	0,939

**Table 3 – Altitude correction factors**

Elvation above sea level (m)	0	300	600	900	1200	1500	1800
Barometric pressure (mbar)	1013	977	942	908	875	843	812
Cooling cap.correction factor	1,000	0,993	0,986	0,979	0,973	0,967	0,960
Power input correction factor	1,000	1,005	1,009	1,015	1,021	1,026	1,031

**Table 5 – Ethylene glycol and low ambient temperature correction factors**

Air ambient temperature °C	-3	-8	-14	-22	-33
% of ethylene glycol by weight	10	20	30	40	50
Cooling capacity correction factor	0,991	0,982	0,972	0,961	0,946
Power input correction factor	0,996	0,992	0,986	0,976	0,966
Flow rate correction factor	1,013	1,040	1,074	1,121	1,178
Water pressure drops correction factor	1,070	1,129	1,181	1,263	1,308

## Installation notes

### Handling

All moving and handling may damage the unit if some conditions are not scrupulously observed. The units should be lifted with a crane using long ropes anchored to the holes on the frame of the unit's base and by using the upper spacer bars to prevent the ropes from damaging the condenser coils.

### Location

The MHR units are produced for outside installation on roofs, floors or below ground level on condition that the area is free from obstacles for the passage of the condensation air. The unit should be positioned on solid foundations and perfectly level; in the case of installation on roofs or floors, it may be advisable to arrange the use of suitable weight distribution beams. When the units are installed on the ground, a concrete base at least 250 mm wider and longer than the unit's footprint should be laid. Furthermore, this base should be sufficiently robust to withstand the unit weight mentioned in the technical data table.

When the units are positioned in areas which are easily accessible by persons or animals, it is advisable to fit guards to protect the condenser coil guards and, when necessary, also guards to protect the compressor.

### Space requirements

The MHR units are air-cooled, hence it is important to observe the minimum distances which guarantee the best ventilation of the coils. Limitations of space reducing the air flow could cause significant reductions in capacity, an

increase in electricity consumption and, in some cases, the unit may stop functioning as a result of the high condensation pressure. The fans do not allow the use of ducts which have high flow resistance, hence it should be ensured that the output air cannot recycle itself inside the condenser coils. The units should be positioned such that there is sufficient distance between the coils and any obstacles to improve ventilation and also to facilitate inspection. When two or more units are positioned side by side it is recommended that the condenser coils are at least 2500 mm distance from one another. Smaller distances could cause the recirculation of hot air. If the units are positioned in places surrounded by walls or obstacles of the same height as the units, the units should be at least 2000 mm from said obstacles. In the event the obstacles are higher than the units, the units should be at least 2500 mm from the obstacle. For other installation solutions, consult McQuay technicians.

### Acoustic protection

The low noise levels of the MHR units means that they meet most of the most restrictive regulations, thanks to the availability of two versions with different sound levels: the standard version (ST) and the low noise version (LN). When the noise level must meet special requirements it will be necessary to pay the maximum attention to ensure the perfect insulation of the unit from the support base by applying appropriate vibration-dampening devices, applying vibration-dampening mounts on the water pipes and on the electrical connections.

## Nomenclature

### Air to water heat pumps

**Compressor type:** Reciprocating semi-hermetic  
**Size:** Ton  
**N° of compressors**  
**Version:** ST Standard  
 LN Low noise  
**Refrigerant:** 022 HCFC 22  
 407 HFC 407C

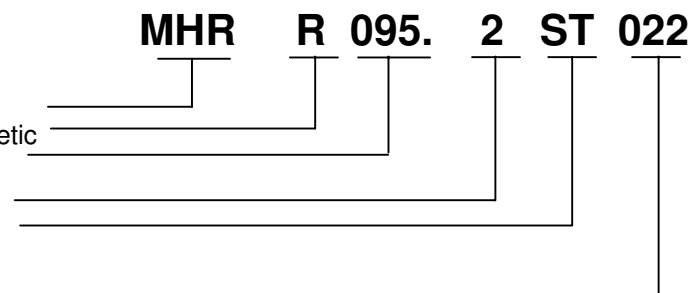

## Physical data MHR ST 050.2÷110.2

"MHR ST" unit size		050.2	055.2	060.2	065.2	070.2	075.2
Cooling capacity HFC 407C (1)	kW	163,4	180,8	198,1	224,7	243,5	258,2
Power input HFC 407C (1)	kW	57,9	63,2	68,5	72,0	79,3	80,6
Heating capacity HFC 407C (2)	kW	176,0	191,8	207,6	230,6	253,5	263,7
Power input HFC 407C (2)	kW	51,9	56,5	61,1	67,6	73,0	74,4
Cooling capacity HCFC 22 (1)	kW	168,4	186,3	204,2	231,6	251,0	266,2
Power input HCFC 22 (1)	kW	57,9	63,2	68,5	71,9	79,2	80,6
Heating capacity HCFC 22 (2)	kW	185,3	201,9	218,5	242,7	266,8	277,5
Power input HCFC 22 (2)	kW	51,9	56,5	61,1	67,6	73,0	74,3
Compressor type / N° of compressors		recip / 2	recip / 2	recip / 2	recip / 2	recip / 2	recip / 2
N° of circuits		2	2	2	2	2	2
N° of reduction steps		4	4	4	4	4	4
<b>Condenser fans</b>							
N° of fans / Nominal fan power input	kW	4 / 2,1	4 / 2,1	4 / 2,1	4 / 2,1	4 / 2,1	4 / 2,1
Total air flow	m <sup>3</sup> /s	26,1	25,5	25,3	25,3	25,3	39,1
<b>Evaporator</b>							
N° of evaporators		1	1	1	1	1	1
Max operating pressure	bar	10,5	10,5	10,5	10,5	10,5	10,5
Water volume	l	60	60	60	100	100	90
<b>Condenser coil</b>							
N° of condenser coils		2	4	4	4	4	4
<b>Weight</b>							
Operating weight	kg	1600	2000	2080	2130	2210	2220
Shipping weight	kg	1520	1940	2020	2030	2110	2130

"MHR ST" unit size		080.2	085.2	090.2	095.2	100.2	110.2
Cooling capacity HFC 407C (1)	kW	270,7	298,0	312,0	328,2	348,5	368,8
Power input HFC 407C (1)	kW	86,6	94,0	97,0	104,0	110,5	117,0
Heating capacity HFC 407C (2)	kW	278,1	302,7	305,2	328,7	341,1	353,4
Power input HFC 407C (2)	kW	79,9	86,8	85,1	92,0	97,0	102,0
Cooling capacity HCFC 22 (1)	kW	279,1	307,2	321,6	338,3	359,2	380,1
Power input HCFC 22 (1)	kW	56,6	94,0	97,0	104,0	110,5	117,0
Heating capacity HCFC 22 (2)	kW	292,7	318,6	321,3	346,0	359,0	372,0
Power input HCFC 22 (2)	kW	79,9	86,8	85,1	92,0	97,0	102,0
Compressor type / N° of compressors		recip / 2	recip / 2	recip / 2	recip / 2	recip / 2	recip / 2
N° of circuits		2	2	2	2	2	2
N° of reduction steps		4	4	4	4	4	4
<b>Condenser fans</b>							
N° of fans / Nominal fan power input	kW	6 / 2,1	6 / 2,1	6 / 2,1	6 / 2,1	6 / 2,1	6 / 2,1
Total air flow	m <sup>3</sup> /s	39,1	39,1	39,1	39,1	39,1	39,1
<b>Evaporator</b>							
N° of evaporators		1	1	1	1	1	1
Max operating pressure	bar	10,5	10,5	10,5	10,5	10,5	10,5
Water volume	l	90	90	90	90	90	90
<b>Condenser coil</b>							
N° of condenser coils		4	4	4	4	4	4
<b>Weight</b>							
Operating weight	kg	2950	2990	3000	3600	3600	3600
Shipping weight	kg	2860	2900	2915	3515	3515	3515

**Notes:** (1) Nominal cooling capacity are based on: 12/7°C entering/leaving evaporator water temperature; 35°C ambient temperature.  
(2) Heating capacity based on 40/45°C hot water temperature, air ambient temperature 7°C 90% R.H.

## Sound pressure levels MHR ST 050.2 ÷ 110.2

Unit size	Sound pressure level at 1 m from the unit in free field ( rif. $2 \times 10^{-5}$ )								
	63 Hz	125 Hz	250 Hz	500 Hz	1000 Hz	2000 Hz	4000 Hz	8000 Hz	dBA
MHR ST 050.2	73,5	74,0	76,0	75,0	74,0	72,0	63,0	58,5	78,5
MHR ST 055.2	74,5	75,0	77,0	76,0	75,0	73,0	64,0	59,5	79,5
MHR ST 060.2	74,5	75,0	77,0	76,0	75,0	73,0	64,0	59,5	79,5
MHR ST 065.2	74,5	75,0	77,0	76,0	75,0	73,0	64,0	59,5	79,5
MHR ST 070.2	74,5	75,0	77,0	76,0	75,0	73,0	64,0	59,5	79,5
MHR ST 075.2	74,5	75,0	77,0	76,0	75,0	73,0	64,0	59,5	79,5
MHR ST 080.2	74,5	75,0	77,0	76,0	75,0	73,0	64,0	59,5	79,5
MHR ST 085.2	74,5	75,0	77,0	76,0	75,0	73,0	64,0	59,5	79,5
MHR ST 090.2	74,5	75,0	77,0	76,0	75,0	73,0	64,0	59,5	79,5
MHR ST 095.2	76,5	78,5	79,5	79,5	78,0	74,5	71,0	69,5	82,5
MHR ST 100.2	76,5	78,5	79,5	79,5	78,0	74,5	71,0	69,5	82,5
MHR ST 110.2	76,5	78,5	79,5	79,5	78,0	74,5	71,0	69,5	82,5

## Sound pressure levels MHR LN 050.2 ÷ 110.2

Unit size	Sound pressure level at 1 m from the unit in free field ( rif. $2 \times 10^{-5}$ )								
	63 Hz	125 Hz	250 Hz	500 Hz	1000 Hz	2000 Hz	4000 Hz	8000 Hz	dBA
MHR LN 050.2	70,0	70,0	69,0	67,0	65,0	62,0	58,0	53,0	70,0
MHR LN 055.2	70,0	70,0	69,0	67,0	65,0	62,0	58,0	53,0	70,0
MHR LN 060.2	71,0	71,0	71,0	68,5	66,0	62,5	58,0	53,0	71,0
MHR LN 065.2	71,0	71,0	72,0	69,5	67,0	63,5	59,0	53,0	72,0
MHR LN 070.2	71,0	71,0	72,0	69,5	67,0	63,5	59,0	53,0	72,0
MHR LN 075.2	71,0	71,0	72,0	69,5	67,0	63,5	59,0	53,0	72,0
MHR LN 080.2	71,0	71,0	72,0	69,5	67,0	63,5	59,0	53,0	72,0
MHR LN 085.2	71,0	71,0	72,0	69,5	67,0	63,5	59,0	53,0	72,0
MHR LN 090.2	71,0	71,0	72,0	69,5	67,0	63,5	59,0	53,0	72,0
MHR LN 095.2	74,0	75,0	74,5	71,5	68,0	64,5	59,5	53,5	73,5
MHR LN 100.2	74,0	75,0	74,5	71,5	68,0	64,5	59,5	53,5	73,5
MHR LN 110.2	74,0	75,0	74,5	71,5	68,0	64,5	59,5	53,5	73,5

## Electrical data MHR ST 080.2 ÷ 110.2

"MHR ST" unit size HCFC 22		050.2	055.2	060.2	065.2	070.2	075.2
Standard voltage		400 V – 3f – 50 Hz (1)					
Total compr. absorbed current nom. cond. (2)	A	102,8	107,7	112,6	128,9	150,4	152,4
Max absorbed current each compressor (3)	A	65,5/65,5	65,5/70,5	70,5/70,5	70,5/92	92/92	92/92
Max inrush current bigger compressor PW	A	202,0	247,0	247,0	286,0	286,0	286,0
Total fans absorbed current nom. cond. (2)	A	15,2	15,2	15,2	15,2	15,2	15,2
Total unit absorbed current nom. cond. (2)	A	118,0	122,9	127,8	144,1	165,6	167,6
Max unit absorbed current (3)	A	146,2	151,2	159,2	177,7	199,2	199,2
Max unit inrush current PW (5)	A	274,5	320,5	325,5	370,5	392,0	392,0

"MHR ST" unit size HCFC 22		080.2	085.2	090.2	095.2	100.2	110.2
Standard voltage		400 V – 3f – 50 Hz (1)					
Total compr. absorbed current nom. cond. (2)	A	164,2	178,0	182,6	180,8	192,1	203,4
Max absorbed current each compressor (3)	A	92/112	112/112	112/112	98/98	98/114	114/114
Max inrush current bigger compressor PW	A	347,0	347,0	347,0	345,0	537,0	537,0
Total fans absorbed current nom. cond. (2)	A	22,8	22,8	22,8	22,8	22,8	22,8
Total unit absorbed current nom. cond. (2)	A	187,0	200,8	205,4	203,6	214,9	226,2
Max unit absorbed current (3)	A	216,8	246,8	246,8	218,8	234,8	250,8
Max unit inrush current PW (5)	A	462,0	482,0	482,0	466,0	657,0	673,8

Notes: (1) Allowed voltage tolerance  $\pm 10\%$ .

(2) Absorbed current nominal condition (summer): 12/7°C entering/leaving evaporator water temp.; 35°C ambient temperature.

(3) Absorbed current max. condition: 9°C leaving evaporator water temperature; 42°C ambient temperature.

(5) PW = Part winding starting, only for second compressor.



# Standard ratings MHR ST 050.2 ÷ 080.2 HCFC 22

Unit size	Evap. leaving water temp. °C	AIR AMBIENT TEMPERATURE - °C									
		25		30		35		38		42	
		Cooling capacity kW	Power input kW	Cooling capacity kW	Power input kW	Cooling capacity kW	Power input kW	Cooling capacity kW	Power input kW	Cooling capacity kW	Power input kW
050.2	4	170,1	44,9	163,1	50,8	156,2	56,5	149,3	62,4	147,0	64,4
	5	174,1	45,2	167,1	51,2	160,2	57,0	153,3	63,0	151,0	65,0
	6	178,2	45,6	171,2	51,5	164,3	57,5	157,4	63,5	155,1	65,5
	7	182,4	45,8	175,4	51,8	168,5	57,9	161,6	64,0	159,3	66,0
	8	186,6	46,0	179,6	52,2	172,7	58,3	165,8	64,4	163,5	66,5
	9	190,6	46,3	183,6	52,5	176,7	58,7	169,7	65,0	167,3	67,0
055.2	4	188,1	49,0	180,4	55,5	172,7	61,7	165,1	68,2	162,6	70,3
	5	192,6	49,4	184,9	55,9	177,2	62,3	169,6	68,7	167,1	70,9
	6	197,1	49,8	189,3	56,3	181,7	62,8	174,1	69,3	171,5	71,5
	7	201,8	50,0	194,0	56,6	186,4	63,2	178,7	69,9	176,2	72,1
	8	206,4	50,3	198,7	57,0	191,0	63,7	183,4	70,3	180,8	72,6
	9	210,9	50,5	203,1	57,3	195,5	64,1	187,7	70,9	185,1	73,2
060.2	4	206,2	53,1	197,7	60,1	189,3	66,9	181,0	73,9	178,2	76,2
	5	211,1	53,5	202,6	60,6	194,2	67,5	185,9	74,5	183,1	76,9
	6	216,0	54,0	207,5	61,0	199,1	68,1	190,8	75,1	188,0	77,5
	7	221,1	54,2	212,6	61,4	204,3	68,5	195,9	75,7	193,1	78,1
	8	226,2	54,5	217,8	61,8	209,4	69,0	201,0	76,2	198,2	78,7
	9	231,1	54,7	222,6	62,1	214,3	69,5	205,7	76,9	202,9	79,3
065.2	4	233,8	55,8	224,2	63,2	214,7	70,3	205,2	77,6	202,1	80,0
	5	239,4	56,2	229,8	63,6	220,3	70,9	210,8	78,2	207,6	80,7
	6	245,0	56,7	235,3	64,0	225,8	71,5	216,4	78,9	213,2	81,4
	7	250,8	56,9	241,1	64,4	231,6	72,0	222,1	79,5	218,9	82,0
	8	256,6	57,2	246,9	64,9	237,4	72,5	227,9	80,1	224,7	82,6
	9	262,1	57,5	252,4	65,2	243,0	73,0	233,2	80,7	230,1	83,3
070.2	4	253,4	61,4	243,0	69,6	232,6	77,4	222,4	85,5	219,0	88,2
	5	259,4	61,9	249,0	70,1	238,7	78,1	228,4	86,2	225,0	88,9
	6	265,5	62,4	255,0	70,5	244,7	78,7	234,5	86,9	231,0	89,7
	7	271,7	62,7	261,3	71,0	251,0	79,3	240,7	87,6	237,0	90,3
	8	278,0	63,0	267,6	71,5	257,3	79,8	247,0	88,2	243,5	91,0
	9	284,0	63,3	273,6	71,9	263,3	80,4	252,8	88,9	249,3	91,8
075.2	4	268,7	62,5	257,7	70,8	246,7	78,7	235,9	86,9	232,3	89,7
	5	275,1	63,0	264,1	71,3	253,1	79,4	242,3	87,7	238,6	90,4
	6	281,5	63,5	270,5	71,8	259,5	80,1	248,7	88,4	245,0	91,2
	7	288,2	63,7	277,1	72,2	266,2	80,6	255,3	89,1	251,6	91,9
	8	294,9	64,1	283,8	72,7	272,9	81,2	261,9	89,7	258,3	92,6
	9	301,2	64,4	290,1	73,1	279,3	81,8	268,1	90,5	264,4	93,3
080.2	4	281,8	67,2	270,2	76,0	258,7	84,6	247,3	93,4	243,5	96,3
	5	288,5	67,7	276,9	76,6	265,4	85,3	254,0	94,2	250,2	97,2
	6	295,2	68,2	283,6	77,1	272,1	86,0	260,7	95,0	256,9	98,0
	7	302,2	68,5	290,6	77,6	279,1	86,6	267,6	95,7	263,8	98,7
	8	309,1	68,9	297,5	78,1	286,1	87,2	274,6	96,4	270,8	99,5
	9	315,8	69,2	304,2	78,6	292,8	87,8	281,1	97,2	277,2	100,3

- Notes:**
- (1) Ratings based on evaporator fouling factor of 0,44x10<sup>-4</sup>°C/W, evaporator temperature drop of 6°C and sea level altitude.
  - (2) Interpolation is allowed, extrapolation is not permitted. Please contact McQuay for performance outside the standard ratings.
  - (3) The power input is for compressors only.

## Standard ratings MHR ST 085.2 ÷ 110.2 HCFC 22

Unit size	Evap. leaving water temp. °C	AIR AMBIENT TEMPERATURE - °C									
		25		30		35		38		42	
		Cooling capacity kW	Power input kW	Cooling capacity kW	Power input kW	Cooling capacity kW	Power input kW	Cooling capacity kW	Power input kW	Cooling capacity kW	Power input kW
085.2	4	310,1	72,9	297,4	82,5	284,7	91,8	272,2	101,3	268,0	104,5
	5	317,5	73,4	304,7	83,1	292,1	92,6	279,6	102,2	275,4	105,4
	6	324,9	74,0	312,1	83,6	299,5	93,4	287,0	103,1	282,8	106,3
	7	332,6	74,3	319,8	84,1	307,2	94,0	294,6	103,9	290,4	107,1
	8	340,3	74,7	327,5	84,7	314,9	94,6	302,3	104,6	298,1	107,9
	9	347,6	75,1	334,8	85,2	322,3	95,3	309,4	105,4	305,1	108,8
090.2	4	324,7	75,2	311,4	85,1	298,1	94,7	285,0	104,6	280,6	107,9
	5	332,5	75,8	319,1	85,7	305,9	95,5	292,7	105,5	288,3	108,8
	6	340,2	76,4	326,8	86,3	313,6	96,4	300,5	106,4	296,0	109,7
	7	348,2	76,7	334,9	86,9	321,7	97,0	308,5	107,2	304,0	110,6
	8	356,3	77,1	342,9	87,4	329,7	97,7	316,5	107,9	312,1	111,4
	9	363,9	77,5	350,6	88,0	337,4	98,4	323,9	108,8	319,5	112,3
095.2	4	341,6	80,6	327,5	91,3	313,6	101,5	299,8	112,1	295,2	115,6
	5	349,7	81,2	335,6	91,9	321,8	102,4	307,9	113,1	303,3	116,6
	6	357,8	81,9	343,8	92,5	329,9	103,3	316,1	114,0	311,4	117,6
	7	366,3	82,2	352,3	93,1	338,4	104,0	324,5	114,9	319,8	118,5
	8	374,8	82,7	360,7	93,7	346,8	104,7	332,9	115,7	328,3	119,4
	9	382,8	83,1	368,8	94,3	355,0	105,4	340,7	116,7	336,1	120,4
100.2	4	362,7	85,6	347,7	97,0	333,0	107,9	318,3	119,1	313,4	122,9
	5	371,3	86,3	356,4	97,6	341,6	108,8	327,0	120,1	322,1	123,9
	6	379,9	87,0	365,0	98,3	350,3	109,7	335,6	121,2	330,7	125,0
	7	388,9	87,3	374,0	98,9	359,3	110,5	344,5	122,1	339,6	125,9
	8	397,9	87,8	383,0	99,6	368,3	111,3	353,5	122,9	348,6	126,8
	9	406,5	88,3	391,6	100,2	376,9	112,0	361,8	123,9	356,8	127,9
110.2	4	383,8	90,7	368,0	102,7	352,4	114,2	336,9	126,1	331,7	130,1
	5	392,9	91,4	377,1	103,4	361,5	115,2	346,0	127,2	340,8	131,2
	6	402,1	92,1	386,3	104,1	370,6	116,2	355,1	128,3	349,9	132,3
	7	411,6	92,5	395,8	104,7	380,2	117,0	364,6	129,3	359,3	133,3
	8	421,1	93,0	405,3	105,5	389,7	117,8	374,1	130,2	368,8	134,3
	9	430,1	93,5	414,3	106,1	398,8	118,6	382,8	131,2	377,6	135,4

- Notes:** (1) Ratings based on evaporator fouling factor of 0,44x10<sup>-4</sup>°C/W, evaporator temperature drop of 6°C and sea level altitude.  
(2) Interpolation is allowed, extrapolation is not permitted. Please contact McQuay for performance outside the standard ratings.  
(3) The power input is for compressors only.

## Standard ratings MHR LN 050.2 ÷ 080.2 HCFC 22

Unit size	Evap. leaving water temp. °C	AIR AMBIENT TEMPERATURE - °C									
		25		30		35		38 (*)		42 (*)	
		Cooling capacity kW	Power input kW	Cooling capacity kW	Power input kW	Cooling capacity kW	Power input kW	Cooling capacity kW	Power input kW	Cooling capacity kW	Power input kW
050.2	4	163,3	46,2	156,6	52,4	149,9	58,2	146,0	61,9	147,0	64,4
	5	167,2	46,6	160,4	52,7	153,8	58,7	149,8	62,4	151,0	65,0
	6	171,1	47,0	164,3	53,1	157,7	59,2	153,7	62,9	155,1	65,5
	7	175,1	47,2	168,4	53,4	161,7	59,7	157,8	63,4	159,3	66,0
	8	179,2	47,4	172,4	53,8	165,8	60,1	161,8	63,9	163,5	66,5
	9	183,0	47,7	176,3	54,1	169,7	60,5	165,6	64,3	167,3	67,0
055.2	4	180,6	50,5	173,2	57,2	165,8	63,6	161,4	67,6	162,6	70,3
	5	184,9	50,9	177,5	57,6	170,1	64,1	165,7	68,1	167,1	70,9
	6	189,2	51,3	181,8	58,0	174,4	64,7	170,0	68,7	171,5	71,5
	7	193,7	51,5	186,3	58,3	178,9	65,1	174,5	69,2	176,2	72,1
	8	198,2	51,8	190,7	58,7	183,4	65,6	179,0	69,7	180,8	72,6
	9	202,4	52,0	195,0	59,1	187,7	66,0	183,2	70,2	185,1	73,2
060.2	4	197,9	54,7	189,8	62,0	181,7	68,9	176,9	73,2	178,2	76,2
	5	202,7	55,2	194,5	62,4	186,5	69,5	181,7	73,9	183,1	76,9
	6	207,4	55,6	199,2	62,8	191,2	70,1	186,4	74,5	188,0	77,5
	7	212,3	55,8	204,1	63,2	196,1	70,6	191,2	75,0	193,1	78,1
	8	217,2	56,1	209,0	63,6	201,0	71,1	196,2	75,6	198,2	78,7
	9	221,9	56,4	213,7	64,0	205,7	71,6	200,8	76,1	202,9	79,3
065.2	4	224,5	57,4	215,2	65,0	206,1	72,4	200,6	76,9	202,1	80,0
	5	229,8	57,9	220,6	65,5	211,4	73,0	206,0	77,5	207,6	80,7
	6	235,2	58,4	225,9	66,0	216,8	73,6	211,3	78,2	213,2	81,4
	7	240,7	58,6	231,5	66,4	222,3	74,1	216,9	78,8	218,9	82,0
	8	246,3	58,9	237,0	66,8	227,9	74,6	222,4	79,3	224,7	82,6
	9	251,6	59,2	242,3	67,2	233,3	75,1	227,6	79,9	230,1	83,3
070.2	4	243,3	63,3	233,2	71,7	223,3	79,7	217,4	84,7	219,0	88,2
	5	249,0	63,8	239,0	72,2	229,1	80,4	223,2	85,4	225,0	88,9
	6	254,8	64,3	244,8	72,7	234,9	81,1	229,0	86,2	231,0	89,7
	7	260,9	64,5	250,9	73,1	241,0	81,7	235,0	86,8	237,3	90,3
	8	266,9	64,9	256,9	73,6	247,0	82,2	241,1	87,4	243,5	91,0
	9	272,6	65,2	262,6	74,0	252,8	82,8	246,7	88,1	249,3	91,8
075.2	4	258,0	64,4	247,4	72,9	236,9	81,1	230,6	86,2	232,3	89,7
	5	264,1	64,9	253,5	73,4	243,0	81,8	236,8	86,9	238,6	90,4
	6	270,3	65,4	259,6	73,9	249,2	82,5	242,9	87,6	245,0	91,2
	7	276,7	65,6	266,0	74,4	255,6	83,1	249,3	88,3	251,6	91,9
	8	283,1	66,0	272,5	74,8	261,9	83,6	255,7	88,9	258,3	92,6
	9	289,1	66,3	278,5	75,3	268,1	84,2	261,6	89,6	264,4	93,3
080.2	4	270,5	69,2	259,4	78,3	248,4	87,1	241,8	92,6	243,5	96,3
	5	276,9	69,7	265,8	78,9	254,8	87,9	248,2	93,4	250,2	97,2
	6	283,4	70,3	272,2	79,4	261,2	88,6	254,7	94,2	256,9	98,0
	7	290,1	70,5	278,9	79,9	267,9	89,2	261,3	94,9	263,8	98,7
	8	296,8	70,9	285,7	80,4	274,6	89,9	268,0	95,5	270,8	99,5
	9	303,2	71,3	292,0	80,9	281,1	90,5	274,3	96,2	277,2	100,3

(\*) Unit noise level above 38°C corresponds to the ST version.

## Standard ratings MHR LN 085.2 ÷ 110.2 HCFC 22

Unit size	Evap. leaving water temp. °C	AIR AMBIENT TEMPERATURE - °C									
		25		30		35		38 (*)		42 (*)	
		Cooling capacity kW	Power input kW	Cooling capacity kW	Power input kW	Cooling capacity kW	Power input kW	Cooling capacity kW	Power input kW	Cooling capacity kW	Power input kW
085.2	4	297,7	75,1	285,5	85,1	273,4	94,6	266,1	100,5	268,0	104,5
	5	304,8	75,7	292,6	85,6	280,4	95,4	273,2	101,4	275,4	105,4
	6	311,9	76,3	299,6	86,2	287,5	96,3	280,3	102,3	282,8	106,3
	7	319,3	76,6	307,0	86,8	294,9	96,9	287,7	103,0	290,4	107,1
	8	326,7	77,0	314,4	87,4	302,3	97,6	295,0	103,7	298,1	107,9
	9	333,7	77,4	321,4	87,9	309,4	98,3	301,9	104,5	305,1	108,8
090.2	4	311,7	77,5	298,9	87,7	286,2	97,6	278,7	103,7	280,6	107,9
	5	319,2	78,1	306,3	88,3	293,6	98,4	286,1	104,5	288,3	108,8
	6	326,6	78,7	313,7	88,9	301,1	99,2	293,5	105,4	296,0	109,7
	7	334,3	79,0	321,5	89,5	308,8	99,9	301,2	106,2	304,0	110,6
	8	342,0	79,4	329,2	90,1	316,5	100,6	308,9	106,9	312,1	111,4
	9	349,4	79,8	336,6	90,6	324,0	101,3	316,2	107,8	319,5	112,3
095.2	4	327,9	83,0	314,4	94,0	301,1	104,6	293,1	111,1	295,2	115,6
	5	335,7	83,7	322,2	94,7	308,9	105,5	300,9	112,1	303,3	116,6
	6	343,5	84,3	330,0	95,3	316,7	106,4	308,7	113,0	311,4	117,6
	7	351,7	84,7	338,2	95,9	324,8	107,1	316,8	113,9	319,8	118,5
	8	359,8	85,2	346,3	96,5	333,0	107,9	325,0	114,6	328,3	119,4
	9	367,5	85,6	354,0	97,1	340,8	108,6	332,6	115,5	336,1	120,4
100.2	4	348,2	88,2	333,8	99,9	319,7	111,1	311,2	118,1	313,4	122,9
	5	356,5	88,9	342,1	100,6	328,0	112,1	319,5	119,1	322,1	123,9
	6	364,8	89,6	350,4	101,3	336,3	113,0	327,8	120,1	330,7	125,0
	7	373,4	90,0	359,1	101,9	344,9	113,8	336,4	121,0	339,6	125,9
	8	382,0	90,5	367,7	102,6	353,5	114,6	345,0	121,8	348,6	126,8
	9	390,2	90,9	375,9	103,2	361,8	115,4	353,1	122,8	356,8	127,9
110.2	4	368,4	93,4	353,3	105,8	338,3	117,7	329,3	125,0	331,7	130,1
	5	377,2	94,1	362,0	106,5	347,0	118,7	338,1	126,1	340,8	131,2
	6	386,0	94,9	370,8	107,2	355,8	119,7	346,9	127,1	349,9	132,3
	7	395,1	95,2	379,9	107,9	365,0	120,5	356,0	128,1	359,3	133,3
	8	404,2	95,8	389,1	108,6	374,1	121,3	365,1	129,0	368,8	134,3
	9	412,9	96,3	397,8	109,3	382,9	122,2	373,6	130,0	377,6	135,4

(\*) Unit noise level above 38°C corresponds to the ST version.

## Heating capacity ratings MHR ST 050.2 ÷ 110.2 HCFC 22

Unit size	Leaving water temperature °C	AIR AMBIENT TEMPERATURE - °C									
		-5		0		5		7		10	
		Heating capacity kW	Power input kW	Heating capacity kW	Power input kW	Heating capacity kW	Power input kW	Heating capacity kW	Power input kW	Heating capacity kW	Power input kW
050.2	35	140,6	40,3	163,1	43,5	186,4	46,7	195,9	48,0	210,5	49,7
	40	135,8	41,3	158,1	45,0	181,4	48,5	190,7	49,9	205,3	51,9
	45	130,3	42,3	152,5	46,5	175,8	50,3	185,3	51,9	199,8	54,1
	50	124,2	43,3	146,8	48,0	169,9	52,2	179,2	53,9	193,6	54,3
055.2	35	153,2	43,9	177,7	47,3	203,1	50,8	213,4	52,2	229,4	54,1
	40	148,0	44,9	172,2	49,0	197,7	52,8	207,8	54,4	223,7	56,5
	45	141,9	46,0	166,2	50,6	191,6	54,8	201,9	56,5	217,6	58,9
	50	135,3	47,2	159,9	52,2	185,1	56,8	195,2	58,6	211,0	59,1
060.2	35	165,8	47,5	192,3	51,2	219,8	54,9	231,0	56,5	248,2	58,5
	40	160,2	48,6	186,4	53,0	213,9	57,1	224,8	58,8	242,1	61,1
	45	153,6	49,8	179,8	54,7	207,4	59,3	218,5	61,1	235,5	63,7
	50	146,4	51,0	173,1	56,5	200,4	61,4	211,3	63,4	228,3	63,9
065.2	35	184,2	52,5	213,6	56,6	244,2	60,8	256,5	62,5	275,7	64,7
	40	177,9	53,7	207,0	58,7	237,6	63,2	249,7	65,0	268,9	67,6
	45	170,6	55,1	199,7	60,6	230,3	65,6	242,7	67,6	261,6	70,5
	50	162,6	56,4	192,2	62,5	222,6	67,9	234,7	70,2	253,6	70,7
070.2	35	202,5	56,7	234,8	61,2	268,4	65,6	282,0	67,5	303,1	69,9
	40	195,6	58,0	227,6	63,4	261,2	68,3	274,5	70,2	295,6	73,0
	45	187,6	59,5	219,6	65,4	253,2	70,8	266,8	73,0	287,6	76,1
	50	178,8	61,0	211,3	67,5	244,7	73,4	258,0	75,8	278,8	76,4
075.2	35	210,7	57,8	244,3	62,3	279,2	66,8	293,4	68,7	315,3	71,2
	40	203,5	59,1	236,8	64,5	271,7	69,5	285,6	71,5	307,6	74,4
	45	195,1	60,6	228,4	66,6	263,4	72,1	277,6	74,4	299,2	77,6
	50	186,0	62,1	219,8	68,7	254,5	74,7	268,4	77,2	290,1	77,8
080.2	35	222,2	62,1	257,6	67,0	294,5	71,8	309,4	73,8	332,5	76,5
	40	214,5	63,5	249,7	69,4	286,6	74,7	301,2	76,9	324,3	79,9
	45	205,8	65,1	240,9	71,6	277,8	77,5	292,7	79,9	315,5	83,3
	50	196,1	66,7	231,8	73,8	268,4	80,3	283,0	82,9	305,9	83,6
085.2	35	241,8	67,4	280,4	72,7	320,5	78,0	336,8	80,2	361,9	83,1
	40	233,5	69,0	271,8	75,3	311,9	81,2	327,8	83,5	353,0	86,8
	45	224,0	70,7	262,2	77,8	302,4	84,2	318,6	86,8	343,5	90,5
	50	213,5	72,5	252,3	80,2	292,2	87,2	308,1	90,1	332,9	90,8
090.2	35	243,9	66,1	282,7	71,3	323,2	76,5	339,6	78,6	365,0	81,4
	40	235,5	67,7	274,1	73,9	314,6	79,6	330,6	81,9	356,0	85,1
	45	225,9	69,4	264,4	76,2	304,9	82,5	321,3	85,1	346,4	88,8
	50	215,3	71,1	254,5	78,6	294,6	85,5	310,7	88,3	335,8	89,0
095.2	35	262,6	71,5	304,5	77,1	348,1	82,7	365,7	85,0	393,1	88,0
	40	253,6	73,1	295,1	79,9	338,7	86,0	356,0	88,5	383,4	92,0
	45	243,2	75,0	284,8	82,4	328,4	89,2	346,0	92,0	373,0	96,0
	50	231,8	76,8	274,0	85,0	317,3	92,5	334,6	95,5	361,6	96,2
100.2	35	272,4	75,3	315,9	81,2	361,1	87,2	379,4	89,6	407,8	92,8
	40	263,1	77,1	306,2	84,1	351,4	90,6	369,4	93,3	397,7	97,0
	45	252,3	79,0	295,4	86,9	340,6	94,0	359,0	97,0	387,0	101,1
	50	240,5	80,9	284,3	89,6	329,2	97,4	347,1	100,6	375,1	101,4
110.2	35	282,3	79,2	327,3	85,4	374,2	91,6	393,2	94,2	422,5	97,6
	40	282,6	81,0	317,3	88,5	364,1	95,3	382,7	98,1	412,1	102,0
	45	261,5	83,1	306,1	91,3	353,0	98,9	372,0	102,0	401,0	106,3
	50	249,2	85,1	294,6	94,2	341,1	102,5	359,7	105,8	388,7	106,6

# Standard ratings MHR ST 050.2 ÷ 080.2 HFC 407C

Unit size	Evap. leaving water temp. °C	AIR AMBIENT TEMPERATURE - °C									
		25		30		35		38		42	
		Cooling capacity kW	Power input kW	Cooling capacity kW	Power input kW	Cooling capacity kW	Power input kW	Cooling capacity kW	Power input kW	Cooling capacity kW	Power input kW
050.2	4	165,0	44,9	158,2	50,8	151,5	56,5	144,8	62,4	142,6	64,4
	5	168,9	45,2	162,1	51,2	155,4	57,0	148,7	63,0	146,5	65,0
	6	172,8	45,6	166,0	51,5	159,3	57,5	152,7	63,5	150,4	65,5
	7	176,9	45,8	170,1	51,8	163,4	57,9	156,7	64,0	154,5	66,0
	8	181,0	46,0	174,2	52,2	167,5	58,3	160,8	64,4	158,6	66,5
055.2	4	182,5	49,0	175,0	55,5	167,6	61,7	160,2	68,2	157,7	70,3
	5	186,8	49,4	179,3	55,9	171,9	62,3	164,5	68,7	162,0	70,9
	6	191,2	49,8	183,7	56,3	176,2	62,8	168,9	69,3	166,4	71,5
	7	195,7	50,0	188,2	56,6	180,8	63,2	173,3	69,9	170,9	72,1
	8	200,2	50,3	192,7	57,0	185,3	63,7	177,9	70,3	175,4	72,6
060.2	4	204,5	50,5	197,0	57,3	189,6	64,1	182,0	70,9	179,5	73,2
	4	200,0	53,1	191,8	60,1	183,6	66,9	175,6	73,9	172,9	76,2
	5	204,8	53,5	196,5	60,6	188,4	67,5	180,3	74,5	177,6	76,9
	6	209,5	54,0	201,3	61,0	193,2	68,1	185,1	75,1	182,3	77,5
	7	214,5	54,2	206,3	61,4	198,1	68,5	190,0	75,7	187,3	78,1
065.2	8	219,5	54,5	211,2	61,8	203,1	69,0	194,9	76,2	192,2	78,7
	9	224,2	54,7	215,9	62,1	207,8	69,5	199,5	76,9	196,8	79,3
	4	226,8	55,8	217,5	63,2	208,2	70,3	199,1	77,6	196,0	80,0
	5	232,2	56,2	222,9	63,6	213,6	70,9	204,5	78,2	201,4	80,7
	6	237,6	56,7	228,3	64,0	219,0	71,5	209,9	78,9	206,8	81,4
070.2	7	243,2	56,9	233,9	64,4	224,7	72,0	215,4	79,5	212,4	82,0
	8	248,9	57,2	239,5	64,9	230,3	72,5	221,1	80,1	218,0	82,6
	9	254,2	57,5	244,9	65,2	235,7	73,0	226,2	80,7	223,2	83,3
	4	245,8	61,4	235,7	69,6	225,7	77,4	215,7	85,5	212,4	88,2
	5	251,6	61,9	241,5	70,1	231,5	78,1	221,6	86,2	218,3	88,9
075.2	6	257,5	62,4	247,4	70,5	237,4	78,7	227,4	86,9	224,1	89,7
	7	263,6	62,7	253,5	71,0	243,5	79,3	233,5	87,6	230,1	90,3
	8	269,7	63,0	259,6	71,5	249,6	79,8	239,6	88,2	236,2	91,0
	9	275,5	63,3	265,4	71,9	255,4	80,4	245,2	88,9	241,8	91,8
	4	260,7	62,5	249,9	70,8	239,3	78,7	228,8	86,9	225,3	89,7
080.2	5	266,9	63,0	256,1	71,3	245,5	79,4	235,0	87,7	231,5	90,4
	6	273,1	63,5	262,4	71,8	251,7	80,1	241,2	88,4	237,7	91,2
	7	279,5	63,7	268,8	72,2	258,2	80,6	247,6	89,1	244,1	91,9
	8	286,0	64,1	275,3	72,7	264,7	81,2	254,1	89,7	250,5	92,6
	9	292,2	64,4	281,4	73,1	270,9	81,8	260,0	90,5	256,5	93,3
080.2	4	273,3	67,2	262,1	76,0	250,9	84,6	239,9	93,4	236,2	96,3
	5	279,8	67,7	268,6	76,6	257,4	85,3	246,4	94,2	242,7	97,2
	6	286,3	68,2	275,1	77,1	263,9	86,0	252,9	95,0	249,2	98,0
	7	293,1	68,5	281,8	77,6	270,7	86,6	259,6	95,7	255,9	98,7
	8	299,9	68,9	288,6	78,1	277,5	87,2	266,4	96,4	262,7	99,5
9	306,3	69,2	295,1	78,6	284,0	87,8	272,6	97,2	268,9	100,3	

- Notes:**
- (1) Ratings based on evaporator fouling factor of 0,44x10<sup>-4</sup>°C/W, evaporator temperature drop of 6°C and sea level altitude.
  - (2) Interpolation is allowed, extrapolation is not permitted. Please contact McQuay for performance outside the standard ratings.
  - (3) The power input is for compressors only.

# Standard ratings MHR ST 085.2 ÷ 110.2 HFC 407C

Unit size	Evap. leaving water temp. °C	AIR AMBIENT TEMPERATURE - °C									
		25		30		35		38		42	
		Cooling capacity kW	Power input kW	Cooling capacity kW	Power input kW	Cooling capacity kW	Power input kW	Cooling capacity kW	Power input kW	Cooling capacity kW	Power input kW
085.2	4	300,8	72,9	288,4	82,5	276,2	91,8	264,0	101,3	260,0	104,5
	5	308,0	73,4	295,6	83,1	283,4	92,6	271,2	102,2	267,1	105,4
	6	315,2	74,0	302,8	83,6	290,5	93,4	278,4	103,1	274,3	106,3
	7	322,6	74,3	310,2	84,1	298,0	94,0	285,8	103,9	281,7	107,1
	8	330,1	74,7	317,7	84,7	305,5	94,6	293,2	104,6	289,1	107,9
	9	337,2	75,1	324,8	85,2	312,6	95,3	300,1	105,4	296,0	108,8
090.2	4	315,0	75,2	302,0	85,1	289,2	94,7	276,5	104,6	272,2	107,9
	5	322,5	75,8	309,5	85,7	296,7	95,5	284,0	105,5	279,7	108,8
	6	330,0	76,4	317,0	86,3	304,2	96,4	291,5	106,4	287,2	109,7
	7	337,8	76,7	324,8	86,9	312,0	97,0	299,2	107,2	294,9	110,6
	8	345,6	77,1	332,6	87,4	319,8	97,7	307,0	107,9	302,7	111,4
	9	353,0	77,5	340,1	88,0	327,3	98,4	314,2	108,8	309,9	112,3
095.2	4	331,3	80,6	317,7	91,3	304,2	101,5	290,8	112,1	286,4	115,6
	5	339,2	81,2	325,6	91,9	312,1	102,4	298,7	113,1	294,2	116,6
	6	347,1	81,9	333,5	92,5	320,0	103,3	306,6	114,0	302,1	117,6
	7	355,3	82,2	341,7	93,1	328,2	104,0	314,7	114,9	310,2	118,5
	8	363,5	82,7	349,9	93,7	336,4	104,7	322,9	115,7	318,4	119,4
	9	371,4	83,1	357,7	94,3	344,3	105,4	330,5	116,7	326,0	120,4
100.2	4	351,8	85,6	337,3	97,0	323,0	107,9	308,8	119,1	304,0	122,9
	5	360,2	86,3	345,7	97,6	331,4	108,8	317,2	120,1	312,4	123,9
	6	368,5	87,0	354,1	98,3	339,8	109,7	325,5	121,2	320,8	125,0
	7	377,2	87,3	362,8	98,9	348,5	110,5	334,2	122,1	329,4	125,9
	8	386,0	87,8	371,5	99,6	357,3	111,3	342,9	122,9	338,1	126,8
	9	394,3	88,3	379,9	100,2	365,6	112,0	350,9	123,9	346,1	127,9
110.2	4	372,3	90,7	357,0	102,7	341,8	114,2	326,8	126,1	321,7	130,1
	5	381,1	91,4	365,8	103,4	350,7	115,2	335,6	127,2	330,6	131,2
	6	390,0	92,1	374,7	104,1	359,5	116,2	344,4	128,3	339,4	132,3
	7	399,3	92,5	383,9	104,7	368,8	117,0	353,7	129,3	348,5	133,3
	8	408,5	93,0	393,1	105,5	378,0	117,8	362,9	130,2	357,7	134,3
	9	417,2	93,5	401,9	106,1	386,8	118,6	371,3	131,2	366,3	135,4

- Notes:** (1) Ratings based on evaporator fouling factor of 0,44x10<sup>-4</sup>°C/W, evaporator temperature drop of 6°C and sea level altitude.  
(2) Interpolation is allowed, extrapolation is not permitted. Please contact McQuay for performance outside the standard ratings.  
(3) The power input is for compressors only.

## Standard ratings MHR LN 050.2 ÷ 080.2 HFC 407C

Unit size	Evap. leaving water temp. °C	AIR AMBIENT TEMPERATURE - °C									
		25		30		35		38 (*)		42 (*)	
		Cooling capacity kW	Power input kW	Cooling capacity kW	Power input kW	Cooling capacity kW	Power input kW	Cooling capacity kW	Power input kW	Cooling capacity kW	Power input kW
050.2	4	158,4	46,2	151,9	52,4	145,4	58,2	141,6	61,9	142,6	64,4
	5	162,2	46,6	155,6	52,7	149,2	58,7	145,3	62,4	146,5	65,0
	6	165,9	47,0	159,4	53,1	153,0	59,2	149,1	62,9	150,4	65,5
	7	169,9	47,2	163,3	53,4	156,9	59,7	153,0	63,4	154,5	66,0
	8	173,8	47,4	167,3	53,8	160,8	60,1	157,0	63,9	158,6	66,5
	9	177,5	47,7	171,0	54,1	164,6	60,5	160,6	64,3	162,3	67,0
055.2	4	175,2	50,5	168,0	57,2	160,9	63,6	156,6	67,6	157,7	70,3
	5	179,4	50,9	172,2	57,6	165,0	64,1	160,8	68,1	162,0	70,9
	6	183,5	51,3	176,3	58,0	169,2	64,7	164,9	68,7	166,4	71,5
	7	187,9	51,5	180,7	58,3	173,5	65,1	169,3	69,2	170,9	72,1
	8	192,2	51,8	185,0	58,7	177,9	65,6	173,6	69,7	175,4	72,6
	9	196,4	52,0	189,1	59,1	182,1	66,0	177,7	70,2	179,5	73,2
060.2	4	192,0	54,7	184,1	62,0	176,3	68,9	171,6	73,2	172,9	76,2
	5	196,6	55,2	188,7	62,4	180,9	69,5	176,2	73,9	177,6	76,9
	6	201,2	55,6	193,2	62,8	185,4	70,1	180,8	74,5	182,3	77,5
	7	205,9	55,8	198,0	63,2	190,2	70,6	185,5	75,0	187,3	78,1
	8	210,7	56,1	202,8	63,6	195,0	71,1	190,3	75,6	192,2	78,7
	9	215,2	56,4	207,3	64,0	199,5	71,6	194,7	76,1	196,8	79,3
065.2	4	217,7	57,4	208,8	65,0	199,9	72,4	194,6	76,9	196,0	80,0
	5	222,9	57,9	214,0	65,5	205,1	73,0	199,8	77,5	201,4	80,7
	6	228,1	58,4	219,1	66,0	210,3	73,6	205,0	78,2	206,8	81,4
	7	233,5	58,6	224,5	66,4	215,7	74,1	210,4	78,8	212,4	82,0
	8	238,9	58,9	229,9	66,8	221,1	74,6	215,8	79,3	218,0	82,6
	9	244,0	59,2	235,1	67,2	226,3	75,1	220,8	79,9	223,2	83,3
070.2	4	236,0	63,3	226,2	71,7	216,6	79,7	210,9	84,7	212,4	88,2
	5	241,6	63,8	231,9	72,2	222,3	80,4	216,5	85,4	218,3	88,9
	6	247,2	64,3	237,5	72,7	227,9	81,1	222,2	86,2	224,1	89,7
	7	253,0	64,5	243,3	73,1	233,7	81,7	228,0	86,8	230,1	90,3
	8	258,9	64,9	249,2	73,6	239,6	82,2	233,8	87,4	236,2	91,0
	9	264,5	65,2	254,7	74,0	245,2	82,8	239,3	88,1	241,8	91,8
075.2	4	250,2	64,4	239,9	72,9	229,8	81,1	223,7	86,2	225,3	89,7
	5	256,2	64,9	245,9	73,4	235,7	81,8	229,6	86,9	231,5	90,4
	6	262,2	65,4	251,9	73,9	241,7	82,5	235,6	87,6	237,7	91,2
	7	268,4	65,6	258,1	74,4	247,9	83,1	241,8	88,3	244,1	91,9
	8	274,6	66,0	264,3	74,8	254,1	83,6	248,0	88,9	250,5	92,6
	9	280,5	66,3	270,2	75,3	260,0	84,2	253,8	89,6	256,5	93,3
080.2	4	262,4	69,2	251,6	78,3	240,9	87,1	234,5	92,6	236,2	96,3
	5	268,6	69,7	257,8	78,9	247,1	87,9	240,8	93,4	242,7	97,2
	6	274,9	70,3	264,1	79,4	253,4	88,6	247,0	94,2	249,2	98,0
	7	281,4	70,5	270,6	79,9	259,9	89,2	253,5	94,9	255,9	98,7
	8	287,9	70,9	277,1	80,4	266,4	89,9	260,0	95,5	262,7	99,5
	9	294,1	71,3	283,3	80,9	272,7	90,5	266,1	96,2	268,9	100,3

(\*) Unit noise level above 38°C corresponds to the ST version.



## Standard ratings MHR LN 085.2 ÷ 110.2 HFC 407C

Unit size	Evap. leaving water temp. °C	AIR AMBIENT TEMPERATURE - °C									
		25		30		35		38 (*)		42 (*)	
		Cooling capacity kW	Power input kW	Cooling capacity kW	Power input kW	Cooling capacity kW	Power input kW	Cooling capacity kW	Power input kW	Cooling capacity kW	Power input kW
085.2	4	288,8	75,1	276,9	85,1	265,2	94,6	258,2	100,5	260,0	104,5
	5	295,7	75,7	283,8	85,6	272,0	95,4	265,0	101,4	267,1	105,4
	6	302,5	76,3	290,7	86,2	278,9	96,3	271,9	102,3	274,3	106,3
	7	309,7	76,6	297,8	86,8	286,1	96,9	279,0	103,0	281,7	107,1
	8	316,9	77,0	305,0	87,4	293,2	97,6	286,2	103,7	289,1	107,9
	9	323,7	77,4	311,8	87,9	300,1	98,3	292,9	104,5	296,0	108,8
090.2	4	302,4	77,5	289,9	87,7	277,6	97,6	270,3	103,7	272,2	107,9
	5	309,6	78,1	297,1	88,3	284,8	98,4	277,5	104,5	279,7	108,8
	6	316,8	78,7	304,3	88,9	292,0	99,2	284,7	105,4	287,2	109,7
	7	324,3	79,0	311,8	89,5	299,5	99,9	292,2	106,2	294,9	110,6
	8	331,8	79,4	319,3	90,1	307,0	100,6	299,7	106,9	302,7	111,4
	9	338,9	79,8	326,5	90,6	314,2	101,3	306,7	107,8	309,9	112,3
095.2	4	318,1	83,0	305,0	94,0	292,0	104,6	284,3	111,1	286,4	115,6
	5	325,7	83,7	312,6	94,7	299,6	105,5	291,9	112,1	294,2	116,6
	6	333,2	84,3	320,1	95,3	307,2	106,4	299,5	113,0	302,1	117,6
	7	341,1	84,7	328,0	95,9	315,1	107,1	307,3	113,9	310,2	118,5
	8	349,0	85,2	335,9	96,5	323,0	107,9	315,2	114,6	318,4	119,4
	9	356,5	85,6	343,4	97,1	330,5	108,6	322,6	115,5	326,0	120,4
100.2	4	337,8	88,2	323,8	99,9	310,1	111,1	301,9	118,1	304,0	122,9
	5	345,8	88,9	331,8	100,6	318,2	112,1	309,9	119,1	312,4	123,9
	6	353,9	89,6	339,9	101,3	326,2	113,0	318,0	120,1	320,8	125,0
	7	362,2	90,0	348,3	101,9	334,6	113,8	326,3	121,0	329,4	125,9
	8	370,5	90,5	356,7	102,6	342,9	114,6	334,7	121,8	338,1	126,8
	9	378,5	90,9	364,6	103,2	350,9	115,4	342,5	122,8	346,1	127,9
110.2	4	357,3	93,4	342,7	105,8	328,2	117,7	319,4	125,0	321,7	130,1
	5	365,9	94,1	351,1	106,5	336,6	118,7	328,0	126,1	330,6	131,2
	6	374,4	94,9	359,7	107,2	345,1	119,7	336,5	127,1	339,4	132,3
	7	383,2	95,2	368,5	107,9	354,1	120,5	345,3	128,1	348,5	133,3
	8	392,1	95,8	377,4	108,6	362,9	121,3	354,1	129,0	357,7	134,3
	9	400,5	96,3	385,9	109,3	371,4	122,2	362,4	130,0	366,3	135,4

(\*) Unit noise level above 38°C corresponds to the ST version.

## Heating capacity ratings MHR ST 050.2 ÷ 110.2 HFC 407C

Unit size	Leaving water temperature °C	AIR AMBIENT TEMPERATURE - °C									
		-5		0		5		7		10	
		Heating capacity kW	Power input kW	Heating capacity kW	Power input kW	Heating capacity kW	Power input kW	Heating capacity kW	Power input kW	Heating capacity kW	Power input kW
050.2	35	133,6	40,3	154,9	43,5	177,1	46,7	186,1	48,0	200,0	49,7
	40	129,0	41,3	150,2	45,0	172,3	48,5	181,1	49,9	195,0	51,9
	45	123,8	42,3	144,9	46,5	167,1	50,3	176,0	51,9	189,8	54,1
055.2	35	145,6	43,9	168,8	47,3	193,0	50,8	202,7	52,2	217,9	54,1
	40	140,6	44,9	163,6	49,0	187,8	52,8	197,4	54,4	212,5	56,5
	45	134,8	46,0	157,9	50,6	182,0	54,8	191,8	56,5	206,8	58,9
060.2	35	157,5	47,5	182,7	51,2	208,8	54,9	219,4	56,5	235,8	58,5
	40	152,2	48,6	177,1	53,0	203,2	57,1	213,6	58,8	230,0	61,1
	45	145,9	49,8	170,8	54,7	197,0	59,3	207,6	61,1	223,8	63,7
065.2	35	175,0	52,5	202,9	56,6	231,9	60,8	243,7	62,5	261,9	64,7
	40	169,0	53,7	196,7	58,7	225,7	63,2	237,3	65,0	255,5	67,6
	45	162,1	55,1	189,8	60,6	218,8	65,6	230,6	67,6	248,5	70,5
070.2	35	192,4	56,7	223,0	61,2	255,0	65,6	267,9	67,5	287,9	69,9
	40	185,8	58,0	216,2	63,4	248,1	68,3	260,8	70,2	280,8	73,0
	45	178,2	59,5	208,6	65,4	240,5	70,8	253,5	73,0	273,2	76,1
075.2	35	200,1	57,8	232,1	62,3	265,3	66,8	278,7	68,7	299,6	71,2
	40	193,3	59,1	224,9	64,5	258,2	69,5	271,3	71,5	292,2	74,4
	45	185,4	60,6	217,0	66,6	250,2	72,1	263,7	74,4	284,3	77,6
080.2	35	211,1	62,1	244,7	67,0	279,7	71,8	293,9	73,8	315,9	76,5
	40	203,8	63,5	237,2	69,4	272,2	74,7	286,1	76,9	308,1	79,9
	45	195,5	65,1	228,8	71,6	263,9	77,5	278,1	79,9	299,8	83,3
085.2	35	229,7	67,4	266,3	72,7	304,5	78,0	319,9	80,2	343,8	83,1
	40	221,9	69,0	258,2	75,3	296,3	81,2	311,4	83,5	335,4	86,8
	45	212,8	70,7	249,1	77,8	287,2	84,2	302,7	86,8	326,3	90,5
090.2	35	231,7	66,1	268,6	71,3	307,1	76,5	322,6	78,6	346,7	81,4
	40	223,7	67,7	260,4	73,9	298,8	79,6	314,1	81,9	338,2	85,1
	45	214,6	69,4	251,2	76,2	289,7	82,5	305,2	85,1	329,0	88,8
095.2	35	249,5	71,5	289,3	77,1	330,7	82,7	347,4	85,0	373,4	88,0
	40	240,9	73,1	280,4	79,9	321,8	86,0	338,2	88,5	364,2	92,0
	45	231,1	75,0	270,5	82,4	311,9	89,2	328,7	92,0	354,3	96,0
100.2	35	258,8	75,3	300,1	81,2	343,0	87,2	360,4	89,6	387,4	92,8
	40	249,9	77,1	290,9	84,1	333,8	90,6	350,9	93,3	377,8	97,0
	45	239,7	79,0	280,6	86,9	323,6	94,0	341,1	97,0	367,7	101,1
110.2	35	268,2	79,2	310,9	85,4	355,5	91,6	373,5	94,2	401,4	97,6
	40	259,0	81,0	301,4	88,5	345,9	95,3	363,6	98,1	391,5	102,0
	45	248,4	83,1	290,8	91,3	335,4	98,9	353,4	102,0	381,0	106,3

# Water pressure drop

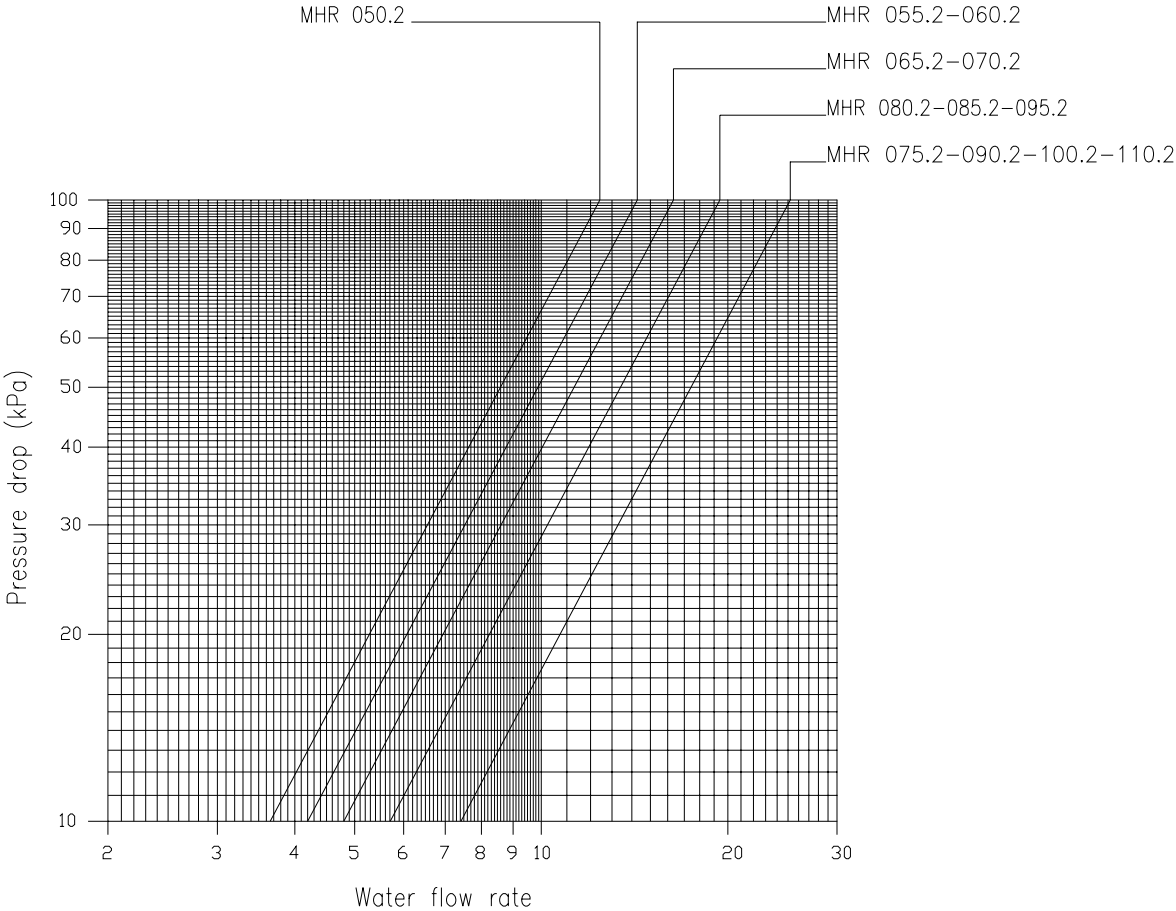

# Dimensions MHR ST, LN 050.2+060.2

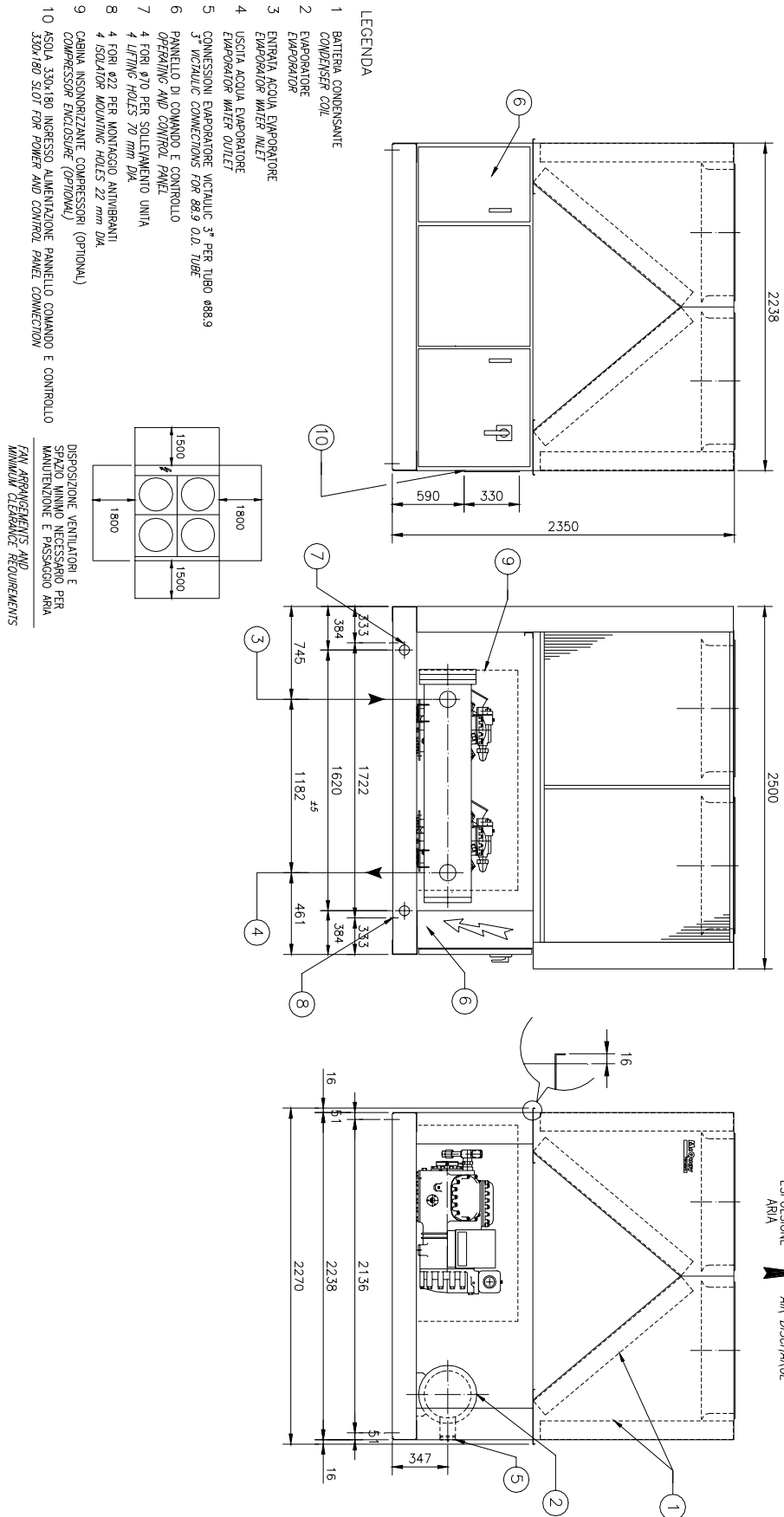

# Dimensions MHR ST, LN 065.2+075.2

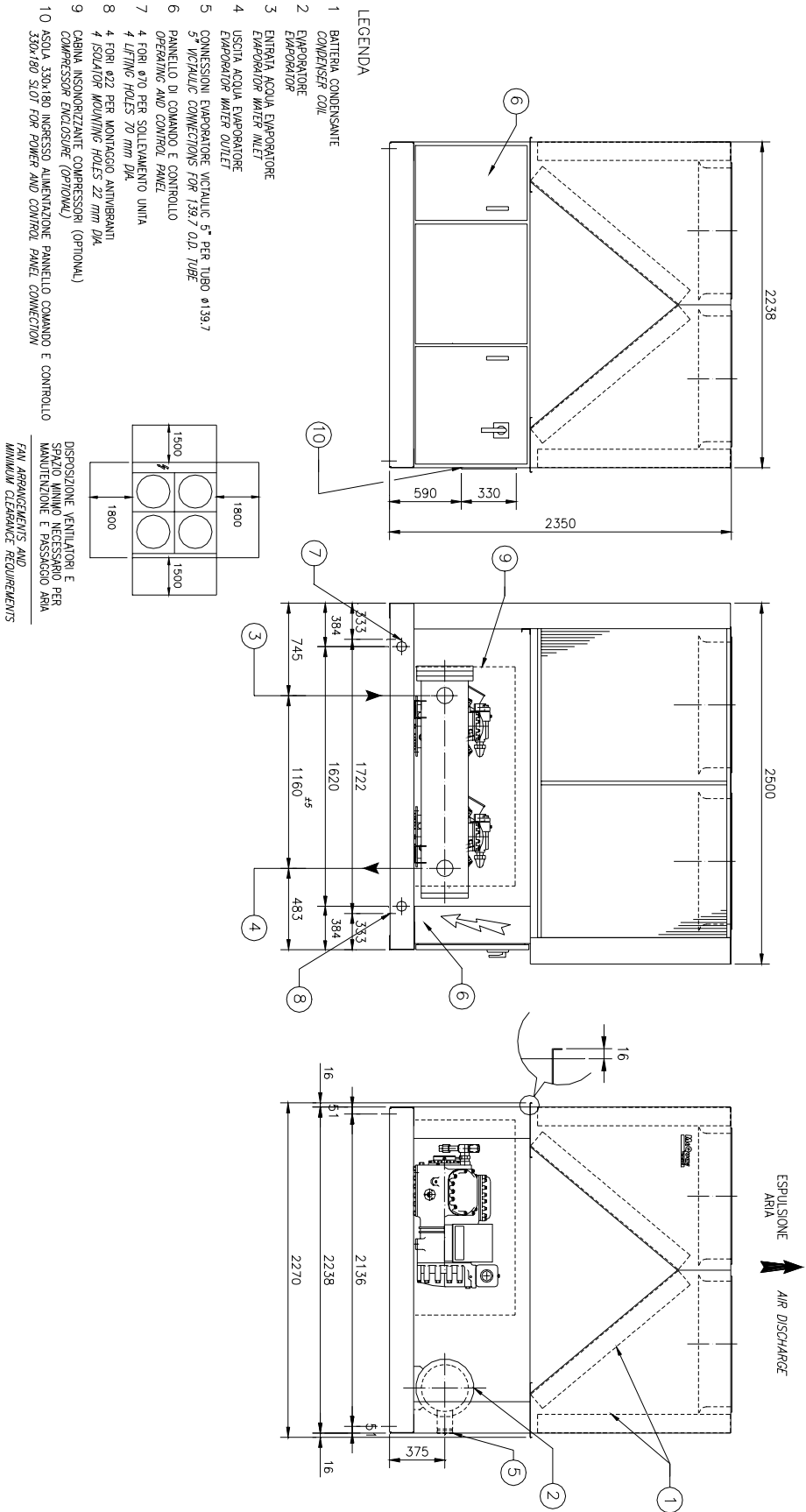

# Dimensions MHR ST, LN 080.2+090.2

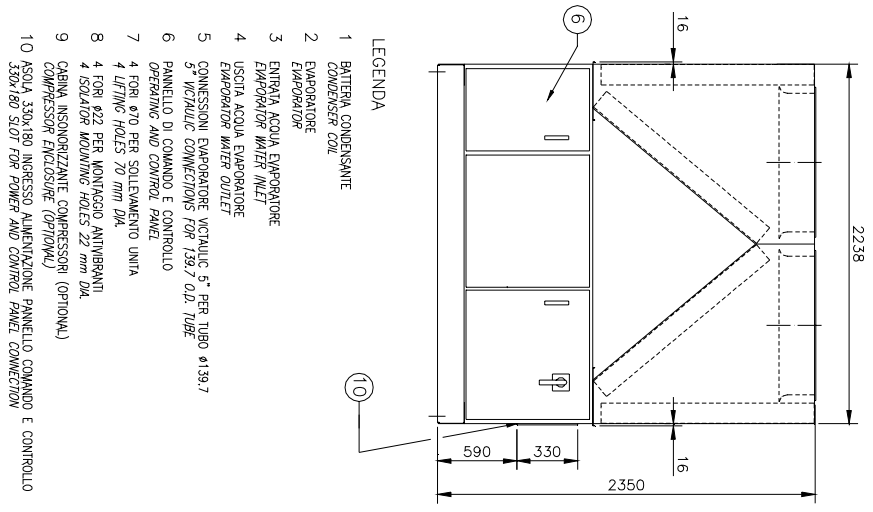

- LEGENDA**
- 1 BATTERIA CONDENSANTE  
CONDENSER COIL
  - 2 EVAPORATORE  
EVAPORATOR
  - 3 ENTRATA ACQUA EVAPORATORE  
EVAPORATOR WATER INLET
  - 4 USCITA ACQUA EVAPORATORE  
EVAPORATOR WATER OUTLET
  - 5 CONNESSIONI EVAPORATORE VITRULIC 5" PER TUBO Ø139.7  
5" VITRULIC CONNECTIONS FOR 139.7 O.D. TUBE
  - 6 PANNELLO DI COMANDO E CONTROLLO  
OPERATING AND CONTROL PANEL
  - 7 4 FORI Ø70 PER SOLLEVAMENTO UNITÀ  
4 LIFTING HOLES 70 mm DIA.
  - 8 4 FORI Ø22 PER MONTAGGIO ANTIVIBRANTI  
4 ISOLATOR MOUNTING HOLES 22 mm DIA.
  - 9 CABINA INSONORIZZANTE COMPRESSORI (OPZIONALE)  
COMPRESSOR ENCLOSURE (OPTIONAL)
  - 10 ASOLA 330x180 INGRESSO ALIMENTAZIONE PANNELLO COMANDO E CONTROLLO  
330x180 SLOT FOR POWER AND CONTROL PANEL CONNECTION

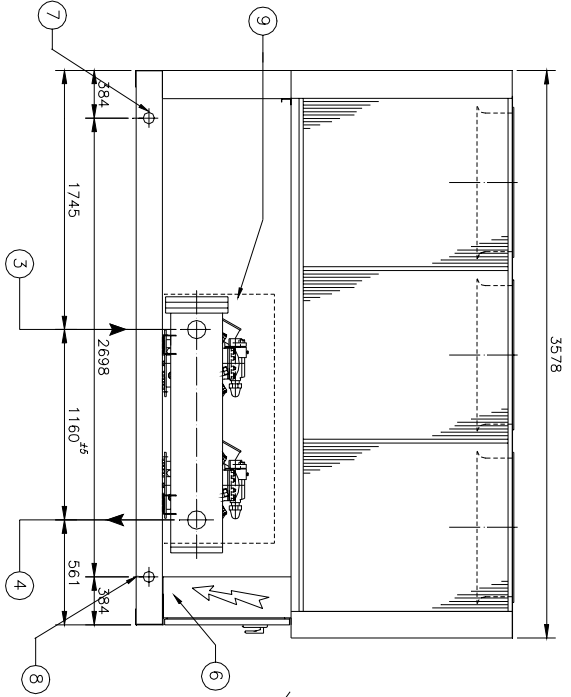

DISPOSIZIONE VENTILATORI E SPAZIO MINIMO NECESSARIO PER MANUTENZIONE E PASSAGGIO ARIA  
FAN ARRANGEMENTS AND MINIMUM CLEARANCE REQUIREMENTS

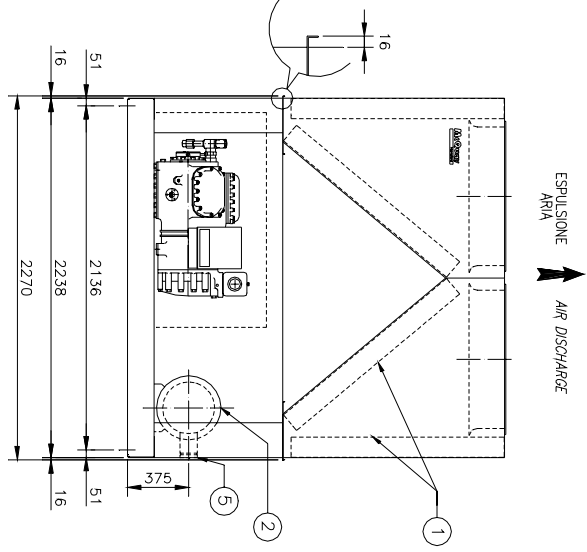
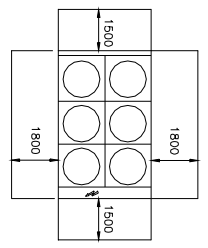

# Dimensions MHR ST, LN 095.2+110.2

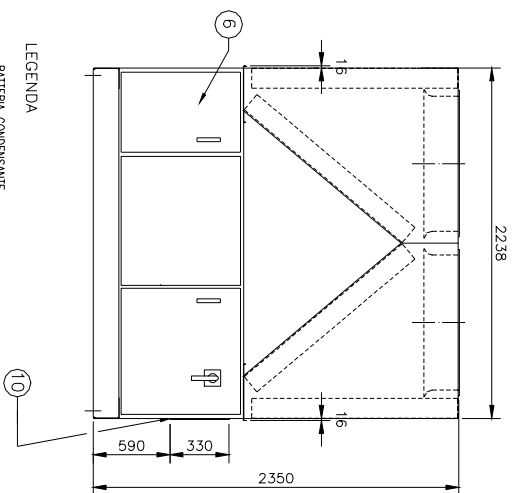

- LEGENDA
- BATTERIA CONDENSANTE
- 1 EVAPORATORE
  - 2 EVAPORATORE
  - 3 ENTRATA ACQUA EVAPORATORE
  - 4 EVAPORATOR WATER INLET
  - 5 USCITA ACQUA EVAPORATORE
  - 4 EVAPORATOR WATER OUTLET
  - 6 CONNESSIONI EVAPORATORE VERTICALI 5" PER TUBO Ø139,7
  - 5 WIRTAHIC CONNECTIONS FOR 139,7 O.D. TUBE
  - 6 PANNELLO DI COMANDO E CONTROLLO OPERATIVO AND CONTROL PANEL
  - 4 FORI Ø70 PER SOLLEVAMENTO UNITA
  - 4 LIFTING HOLES 70 mm DIA.
  - 7 4 FORI Ø22 PER MONTAGGIO ANTIMIBRANTI
  - 4 ISOLATOR MOUNTING HOLES 22 mm DIA.
  - 8 CABINA INSORRIZZANTE COMPRESSORI (OPZIONALE)
  - 9 COMPRESSOR ENCLOSURE (OPTIONAL)
  - 10 ASOLA 330x180 INGRESSO ALIMENTAZIONE PANNELLO COMANDO E CONTROLLO
  - 330x180 SLOT FOR POWER AND CONTROL PANEL CONNECTION

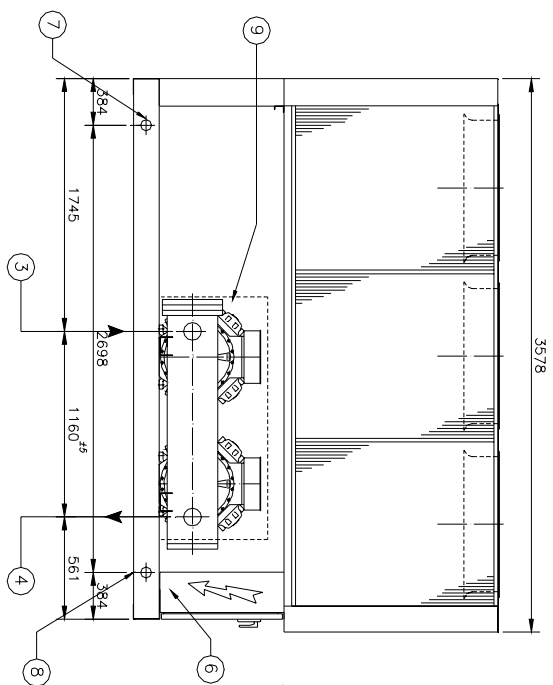

DISPOSIZIONE VENTILATORI E PANNELLO NECESSARIO PER MANUTENZIONE E PULIZIONE PER AIR ARRANGEMENTS AND MAINTENANCE REQUIREMENTS

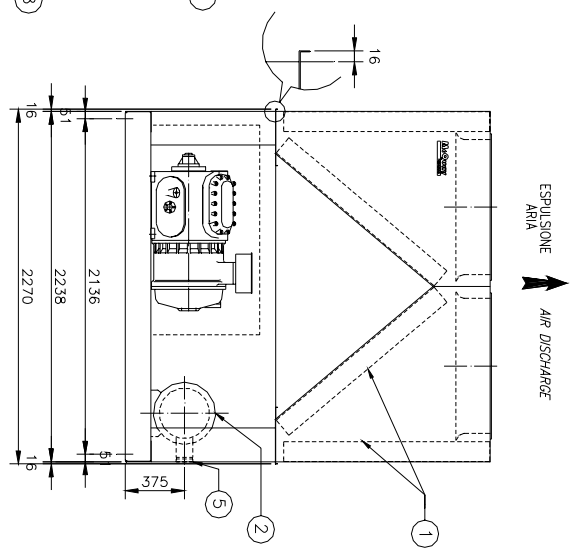
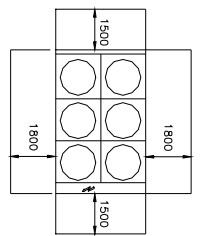

We reserve the right to make changes in design and construction at any time without notice, thus the cover picture is not binding.

McQuay partecipa al programma di  
Certificazione Eurovent.  
I prodotti interessati figurano nella Guida  
Eurovent dei Prodotti Certificati.



McQuay is participating in the Eurovent  
Certification Programme  
Product are as listed in the Eurovent  
Directory of Certified Products

**McQuay**<sup>®</sup>  
International

McQuay Italia S.P.A.

S.S. Nettunense, km 12+300 – 00040 Cecchina (Roma) Italia – Tel. (06) 937311 – Fax (06) 9374014 – Email: [info@mcquayeuropa.com](mailto:info@mcquayeuropa.com)  
[www.mcquayeuropa.com](http://www.mcquayeuropa.com)