

Data: November 2004

Supersedes: 509 B 04/02 A

## Air cooled screw chillers

**Energypus “B” 081.2÷142.2**

**Standard Efficiency – Cooling capacity from 300 to 525 kW**

**High Efficiency – Cooling capacity from 323 to 546 kW**

**High Ambient – Cooling capacity from 318 to 540 kW**

**50Hz – Refrigerant: HFC 134a**

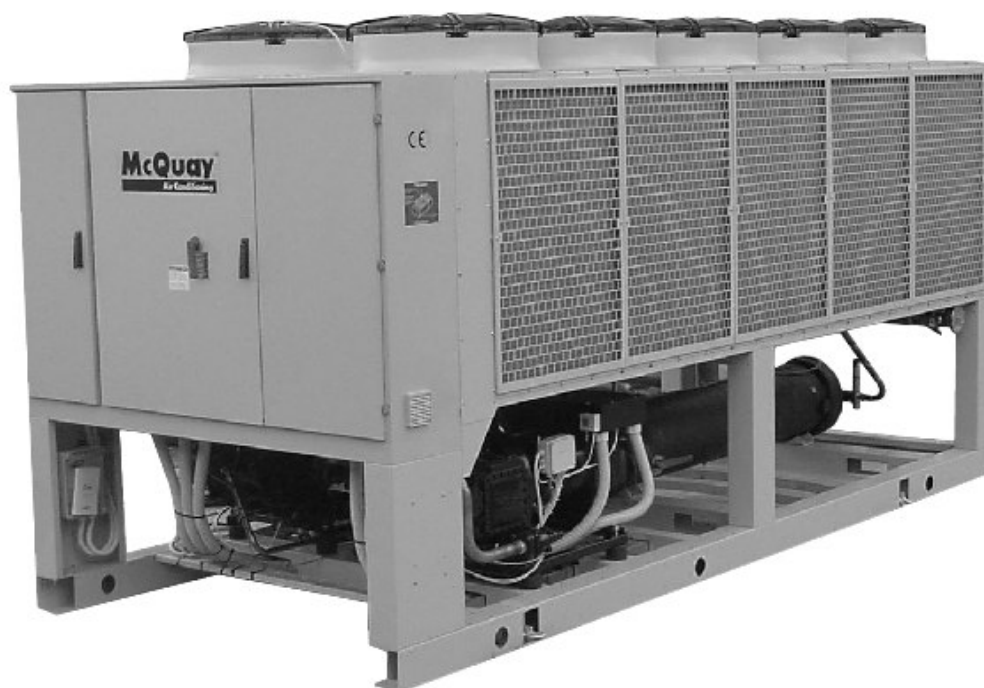

McQuay is participating in the Eurovent Certification Programme. Product are as listed in the Eurovent Directory of Certified Products and on the web site [www.eurovent-certification.com](http://www.eurovent-certification.com)



**McQuay**<sup>®</sup>  
Air Conditioning

# New air cooled screw chillers McQuay Energyplus “B”

McQuay International introduces their newest air cooled screw chillers equipped with new single screw compressors, the first in cooling capacity range 300 kW – 550 kW.

McQuay air cooled ENERGYPLUS “B” are a new range of chillers using the last generation of McQuay Frame 3200 single screw compressors. They are manufactured by McQuay to satisfy the requirements of the consultants and the end user. McQuay ENERGYPLUS “B” units are designed to minimise energy costs while maximising the refrigeration capacities. Once again McQuay has developed a line of chillers unsurpassed in performance and quality that will meet the most stringent requirements of comfort cooling, ice storage and process applications.

McQuay’s chiller design experience, combined with outstanding features makes the Energyplus “B” chiller unmatched in the industry.

## Lower noise – higher flexibility

The McQuay original compressor design with a single screw and twin rotors allows a constant gas flow. This compression process completely eliminates gas pulsations.

The twin gas compressor discharge chambers are designed to act as attenuators, based on the harmonic wave principle with destructive interference, thus always resulting almost equal to zero. The extremely low noise compressor performance allows the use of ENERGYPLUS “B” chiller for all applications.

The reduced level of vibrations produced from the ENERGYPLUS “B” chillers offers a surprisingly quiet operation eliminating the noise transmission through the structure and the chilled water piping system.

## Code requirements

All ENERGYPLUS “B” units are designed and manufactured in accordance with applicable selections of the following which are equivalent to American Air-conditioning industry applicable codes:

Rating of chillers: EN 12055.

Construction of pressure vessel: TUV Standards (on request).

Electrical codes: IEC 204-1 CEI 44-5 Elect. & Safety Codes

Safety Codes: CEI-EN 60204–1 Codes.

Manufacturing Quality Stds: ISO 9001:2000.

## Infinitely variable capacity control

Cooling capacity control is infinitely variable by means of a capacity slide controlled by microprocessor system. Each unit has infinitely variable capacity control from 100% to 12.5%. This modulation allows the compressor capacity to exactly match the building cooling load. The result is a decrease in chiller energy costs, particularly at the part-load conditions at which the chiller operates most of the time.

Additionally, in some case there should be the possibility to avoid inertial tank in the water circuit.

## 11 different lines

ENERGYPLUS “B” 3200 line is available with two different efficiencies in order to satisfy every kind of requirements.

Acoustic flexibility up to 65 dBA thanks to different noise level versions:

- **SE Standard Efficiency**

- **ST** Standard noise – 79,0 ÷ 80,0 dBA
- **CN** Sound proof cabinet on compressors – 77,0 ÷ 78,0 dBA
- **LN** Low noise – 75,0 ÷ 76,0 dBA
- **XN** Extra low noise – 71,0 ÷ 72,0 dBA
- **XXN** Super quiet – 65,0 dBA

- **XE High Efficiency with high COP**

- **ST** Standard noise – 79,0 ÷ 80,0 dBA
- **CN** Sound proof cabinet on compressors – 77,0 ÷ 78,0 dBA
- **LN** Low noise – 75,0 ÷ 76,0 dBA
- **XN** Extra low noise – 71,0 ÷ 72,0 dBA

## **HA High Ambient Applications (suitable for all high ambient application)**

- **ST** Standard noise – 79,0 ÷ 80,0 dBA
- **CN** Sound proof cabinet on compressors – 77,0 ÷ 78,0 dBA

## **Noise version description**

**CN** - The compressors are fitted inside a cabinet which is sound insulated with highly absorbent acoustic material.

**LN** – Condenser fans rotating at 700 rpm. No sound proof cabinet. Discharge flexible pipes.

**XN** – Version including sound proof cabinet, fans having 700 rpm and discharge flexible pipes.

**XXN** – Version including sound proof cabinet, fans having 500 rpm and discharge flexible pipes. Some sizes are equipped with oversized condensing section.

## **Unmatched serviceability**

Field serviceability has not been sacrificed. Inspection covers allows visual inspection of the main screw and gaterotors.

## **Outstanding reliability features**

Full factory testing of all the units ensures a trouble free start-up. Extensive test makes certain that each safety and operating control is properly adjusted, and operates correctly.

## **General characteristics**

### **Cabinet and structure**

The cabinet of ENERGYPLUS “B” units is made of galvanized steel sheet and painted to provide a high resistance to corrosion. The unit base frame has holes to lift the unit with ropes for an easy installation. The weight is uniformly distributed along the profiles of the base and this facilitates the arrangement of the unit.

### **Screw compressors with integrated oil separator**

The newest Stargate™ single-screw compressor (Frame 3200) has a well balanced compression mechanism which cancels the screw rotor load in both the radial and axial directions. Inherent to the basic single-screw compressor design is the virtually load-free operation, that gives main bearing design life of 3-4 times greater than twin-screws, and eliminates expensive and complicated thrust balancing schemes. The two exactly opposed gaterotors create two exactly opposed compression cycles. Compression is made at the lower and upper parts of the screw rotor at the same time, thus cancelling the radial loads. Energyplus “B”o, both ends of the screw rotor are subjected to suction pressure only, which cancels the axial loads and eliminates the huge thrust loads inherent in twin-screw compressors.

Compressors are provided with an integrated high efficiency oil separator to maximise oil separation. Compressors have an infinitely variable capacity control down to 25% of its total capacity. This control is made by means of capacity slides controlled by microprocessors.

Standard start is star-delta type; Soft start type is available (as option) in order to have lower inrush current.

### **Ecological HFC 134a refrigerant**

McQuay has designed and optimized Stargate™ compressors to operate with HFC 134a, ecological refrigerant with zero ODP (Ozone Depletion Potential) and very low GWP (Global Warming Potential) that means low TEWI (Total Equivalent Warming Impact).

### **Evaporator**

The units is supplied with new optimised counter-flow evaporator single refrigerant pass. It is direct expansion with refrigerant inside the tubes and water outside (shell side) with carbon steel tube sheets, with straight copper tubes that are spirally wound internally for higher efficiencies, expanded on the tube plates. The external shell, is linked with an electrical heater to prevent freezing down to -28 °C ambient temperature, commanded by a thermostat and is covered with a closed cell insulation material. Each evaporator have 2 refrigerant circuits one for each compressor. Each evaporator is manufactured in accordance to PED approval.

## Condenser coils

The new ENERGYPLUS "B" units are constructed with internally enhanced seamless copper tubes arranged in a staggered row pattern and mechanically expanded into McQuay lanced and rippled aluminium condenser fins with full fin collars. An integral subcooler circuit provides sub-cooling to effectively eliminate liquid flashing and increases in cooling capacity without increasing the power input.

## Condenser coil fans

The condenser fans are helical type with wing-profile blades to achieve a better performance. The direct coupling with the electrical motor eliminates any problems with regard to the application of transmission devices reducing vibrations caused by the functioning. The three-phase type motors are supplied as standard with IP54 protection (Insulation class F); they are protected against overloading and short circuits by circuit breakers located inside the electrical control panel.

With this new chiller line (McPower with HFC 407C ) McQuay International starts to use a different fan shape (*see image on the right*). The fans, with their blades, are installed immediately at the top of the condenser coils in a circular metal baseframe with metal grill. This allows noise reduction on the top side of the chiller and a better performance of the highest condenser tube rows for a consequent higher air velocity. The chiller height doesn't change thanks to a new condenser coil design.

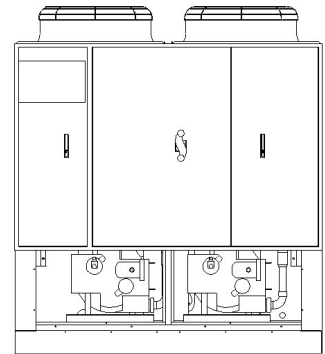

## Expansion device

Energyplus "B" is equipped with a thermostatic expansion valve. Electronic expansion device (EEXV) will be available as option.

## Electrical control panel

Power and control are located into two sections of the main panel that is manufactured to insure protection for all weather conditions.

The power panel is fitted with an interlocked door main isolator to prevent access while power supply is on. Electrical panel is IP54.

**Power section includes** - The power section includes contactors, all compressors fuses, fans circuit breaker (magneto-thermal), and control circuit transformer. Additional space is provided for an easy installation of the various optional accessories provided to enhance the ENERGYPLUS "B" units capabilities.

## Intelligent Compressor Start Mode

Control software includes an intelligent compressor start mode that is unloading the first compressor to 75% during the start of compressor n° 2, in order to reduce inrush current.

## Certifications

All the ENERGYPLUS "B" units are CE marked (89/392).

McQuay Italia obtained ISO 9001:2000 certification.

## Water content in cooling circuits

The cooled water distribution circuits should have a minimum water content to avoid excessive compressors start and stop.

In fact, each time the compressor starts up, an excessive quantity of oil goes from the compressor sump and simultaneously there is a rise in the temperature of the compressor motor's stator due to the inrush current during the start-up. To prevent damage to the compressors, McQuay has envisaged the application of a device to limit frequent stops and restarts.

During the span of one hour there will be no more than 6 starts of the compressor. The plant side should therefore ensure that the overall water content allows a more constant functioning of the unit and consequently greater environmental comfort. The minimum installation water content envisaged should be calculated with a certain approximation using this simplified formula:

$$(1) \quad Q = 35,83 \times \frac{P \text{ (kW)}}{\Delta T (^{\circ}\text{C})} \times \frac{1}{N}$$

where:

Q = Minimum content of the plant expressed in litres

P = Cooling capacity of the plant expressed in kW

$\Delta T$  = Entering/leaving water temperature difference of the evaporator expressed in  $^{\circ}\text{C}$

N = Number of compressors.

For a more accurate determination of the quantity of water, it is advisable to contact the designer of the plant.

## MicroTech II C Plus controller

MicroTech II C Plus controller is installed as standard on all the units; it can be used to modify unit set points and check control parameters. A display illustrates the machine's operating status, programable values and setpoints e.g. temperatures, and pressures of fluids (water, refrigerant and air). Device controls maximise the McQuay chillers energy efficiency and reliability characteristics. It uses sophisticated software with predictive logic to select the most energy efficient combination of compressor, EEXV and condenser fan to keep stable operating conditions and maximise energy efficiency. The compressors are automatically rotated to ensure equal operating hours. MicroTech II protects critical components in response to external signEnergyplus "B" from its system sensors measuring: motor temperatures, refrigerant gas and oil pressures, correct phase sequence and evaporator.

### Control section - main features:

- Management of the compressor capacity slide and fans modulation according to the distributed multiprocessor logic system
- Chillers enabled to work in partial failure condition thanks to the distributed multiprocessor logic system
- Full routine operation at condition of:
  - High ambient temperature value
  - High thermal load
  - High evaporator entering water temperature (start-up)
- Display of evaporator entering/leaving water temperature
- Display of condensing-evaporating temperature and pressure, suction and discharge superheat for each circuit
- Leaving water cooled temperature regulation. Temperature tolerance=0,1  $^{\circ}\text{C}$
- Compressors and evaporator/condenser pumps hours counter
- Display of Status Safety Devices
- Start up numbers and compressors working hours equalization
- Excellent management of compressors load
- Fans management according to condensing pressure

- Automatic re-start in case of power supply interruption (adjustable)
- Soft Load
- Return Reset
- AOT Reset (optional)
- Setpoint Reset (optional)
- Demand limit or Current limit (optional)
- Speedtrol control (optional)

### **Safety for each refrigerant circuit**

High pressure (pressure switch)  
 Low pressure (pressure switch)  
 Oil differential pressure switch  
 Compressor thermal (optional)  
 Condensation fan Magneto-thermal  
 High Discharge Temperature on the compressor  
 Phase Monitor  
 Star / Delta Transition Failed  
 Low Delta Pressure between Suction and Discharge  
 Low pressure ratio  
 High oil pressure drop  
 Low oil pressure

### **System security**

Phase monitor  
 Freeze protection

### **Regulation type**

Proportional + integral + derivative regulation on the leaving water evaporator output probe.

### **Condensation**

The condensation can be carried out according to temperature or pressure. The fans can be managed according to ON/OFF mode or with a 0/10 V modulating signal or both (SPEEDTROL).

### **MicroTech II C Plus terminal**

The MicroTech II C Plus terminal has following features:

- 4-lines by 20-character liquid crystal display back lighting
- Removable and remote key-pad
- Key-pad consisting of 15 keys “ clear language display ”
- Memory to protect the data
- General faults alarm relays
- 4-level password access to modify the setting
- Service report displaying all running hours and general conditions
- Alarm history memory to allow an easy fault analysis

## MicroPlant™: Solution for: tele-maintenance and supervisory systems

MicroTech II can be monitored locally or via modem by MicroPlant™ supervision program, that runs on PC systems under Windows '95 – '98.

### MicroPlant™ is the best solution:

- To centralise all the information in just one local and/or remote PC
- To check all the parameters for each unit connected
- Data logging of temperature - pressure
- Printouts of alarms, parameters and graphs
- To control several plants located in different geographical areas from a central station
- To manage the Service centers

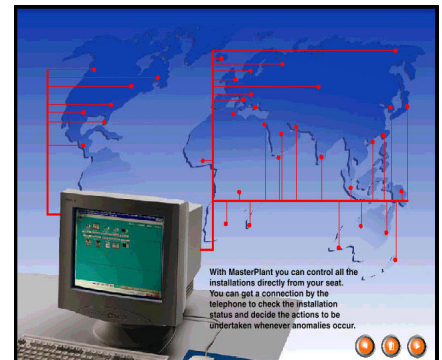

### MicroPlant™ allows:

- Visualization of all working conditions for each controller
- Visualization of their graphics
- Display, print-out of the actual alarms
- Connection between local and remote computer via telephone line (Modem)
- unit ON/OFF
- Set-Point change

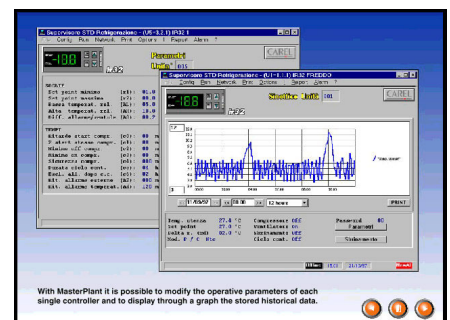

## MicroTech II C Plus remote control

Compatibility with supervisory systems is becoming increasingly important in HVAC. MicroTech II C Plus allows easy interfacing with BMS (Building Management Systems), the external world that can be:

- Full compatible Siemens, Johnson;
- Every MODBUS compatible system; ( Satchwell, Honeywell )
- BacNet point to point, ECHELON FTT10. ( available on request )

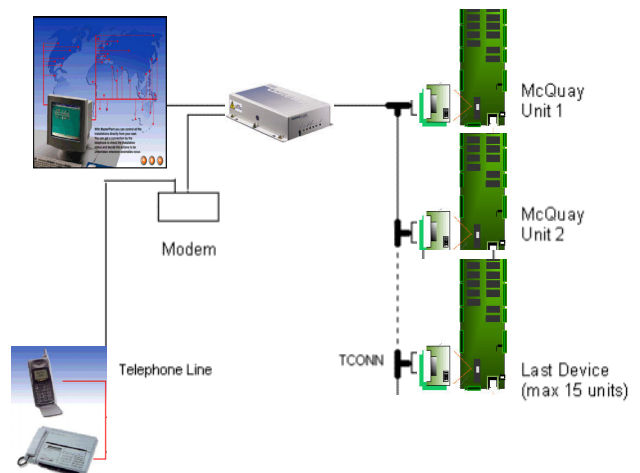

## Standard Accessories (furnished on basic unit)

**Star Delta Compressors starter** – For low inrush current and reduced starting torque.

**Phase monitor** – The phase monitor controls that phases sequence is correct and controls phase loss

**Evaporator electric heater** – Electric heater controlled by a thermostat to protect the evaporator from freezing down to -28°C ambient temperature.

**Evaporator connection water side Victaulic** – Hydraulic joint with gasket for an easy and quick water connection.

**General fault relay** – Contactor for the alarm warning.

**Discharge line shut off valves** – Installed on the discharge port of the compressor.

**External high static pressure fans** – For all the applications where a higher fans lift is required (not available for XXN version – see table 8 and 9, pag.11). This feature is valid only when fans run at full speed.

**Alarm from external device** – Microprocessor is able to receive an alarm signal from an external device (pump etc...). User can decide if this alarm signal will stop or not the unit.

## Options (on request)

**100% total heat recovery R** – Realized with shell and tube heat exchangers to produce hot water up to 55°C. The heat exchangers are mounted on the refrigerant circuits parallel to the condenser coils to remove all the condensation heat. With this option the length of units equipped with 4,6 and 8 fans must be increased of 1250mm. For units equipped with 10 fans the length remains unchanged.

**25% partial heat recovery D** – Produced with plate to plate heat exchangers installed between the compressor discharge and the condenser coil. These allow hot water to be produced up to a maximum temperature of 55°C.

**Compressor thermal overload relays** - Safety devices against compressor motor overloading in addition to the normal protection envisaged by the electrical windings.

**Ammeter and voltmeter** - Digital meters of unit drawn amperes and voltage values, installed on the electrical control panel.

**Condenser power factor correction** - Installed on the electrical control panel to ensure it conforms to the plant rules. (McQuay advises maximum 0,9).

**Brine double set point version (CB)** - Dual leaving glycol mixture temperature setpoints. The lower setpoint can go down to -8°C.

**Absorbed Current Limit / Display** – This options allows to monitor the chiller absorbed current with possibility to set a limit value. This option excludes the Demand Limit.

**250 Pa lift fans** – For all the applications where a higher fans lift is required (not available for LN, XN and XXN version).(Fan speed controller not available with this option)

**Fan speed control device** - This device allows the continuous variation of the fan speed, modifying the air flow according to the external temperature conditions. It allows the unit working with air temperature down to -10°C.

**Speedtrol** – Continuous fan speed modulation on the first fan of each circuit. It allows the unit working with air temperature down to -18 °C.

**Fan Silent Mode** - The microprocessor clock switches the fan at low speed according to the client setting (i.e. Night & Day), providing that the ambient temperature/condensing pressure is allowing the speed change. It allows a perfect condensing control down to -10°C

**Condenser coil guards** - Metal protection guards fixed on all the external surface of the condenser coils.

**Evaporator area guards** – Metal protection guards around evaporator area.

**Cu-Cu condensing coils** - To give better protection against corrosion by aggressive environments.

**Cu-Cu-Sn condensing coils** - To give better protection against corrosion in aggressive environments and by salty air.

**Alucoat condensing coils** - Fins are protected by a special acrylic paint with a high resistance to corrosion.

**Flow switch** - Supplied separately to be wired and installed on the evaporator water piping (by the customer).

**Suction line shut off valve** – Suction shut-off valve installed on the suction port of the compressor to facilitate maintenance operation.



**Spreader bars** - Facilitate the lifting of the units keeping the ropes away from the unit's casing.

**Under/Over Voltage** – This device control the voltage value and stop the chiller when this exceeds limits set by customer.

**Rubber type antivibration mounts** - Supplied separately, these are positioned under the base of the unit during installation. Ideal to reduce the vibrations when the unit is floor mounted.

**Spring type antivibration mounts** - Supplied separately, these are positioned under the base of the unit during installation. Ideal for dampening vibrations for installation on roofs and metallic structures.

**Soft start** – Electronic starting device to reduce inrush current and to start compressors gradually, with very low mechanical stress. An overload protection is included (no need of compressors thermal relays).

**Witness tests** - Every unit is always tested at the test bench prior to the shipment. On request, a second test can be carried out, at customer's presence, in accordance with the procedures indicated on the test form. (Not available for units with Glycol mixtures).

**Water circulation pump** – The pump is unit mounted for chillers with 6,8 and 10 fans. Hydronic kit consists of: one centrifugal pump direct driven, expansion tank, water feed circuit with pressure gauge, safety valve. The pump motor is protected by a circuit breaker installed in control panel. The kit is assembled and wired to the control panel. About units with 4 fans (ENERGYPLUS "B" 081.2 SE ST / CN – ENERGYPLUS "B" 081.2 SE LN / XN) pump is mounted on a metal base frame (1000 x 1000 mm) placed on unit shorter side (that without panel control). See pag. 28 for more information.

**Two water circulation pumps** – Pumps units are unit mounted for chillers with 6,8 and 10 fans. Hydronic kit consists of: two centrifugal pumps direct driven, expansion tank, water feed circuit with pressure gauge, safety valve, check valves, shut-off valves. The pumps motors are protected by circuit breakers installed in control panel. The kit is assembled and wired to the control panel. About units with 4 fans (ENERGYPLUS "B" 081.2 SE ST / CN – ENERGYPLUS "B" 081.2 SE LN / XN) pumps are mounted on a metal base frame (1000 x 1000 mm) placed on unit shorter side (that without panel control). See pag. 28 for more information.

## Installation notes

### Handling

Care should be taken to avoid rough handling or shock due to dropping the unit. Do not push or pull the unit from anything other than the base, and block the pushing vehicle away from the unit to prevent damage to the cabinet. Never allow the unit fall during unloading or moving as this may result in serious damage. To lift the unit, holes are provided in the base of the unit. Spreader bar and cables should be arranged to prevent damage to the condenser coil or unit cabinet.

### Location

The ENERGYPLUS "B" units are produced for outside installation on roofs, floors or below ground level on condition that the area is free from obstacles for the passage of the condenser air. The unit should be positioned on solid foundations and perfectly level; in the case of installation on roofs or floors, it may be advisable to arrange the use of suitable weight distribution beams. When the units are installed on the ground, a concrete base at least 250 mm wider and longer than the unit's footprint should be laid. Furthermore, this base should withstand the unit weight mentioned in the technical data table. When the units are positioned in areas which are easily accessible by persons or animals, it is advisable to fit guards to protect the condenser coil guards and, when necessary, Energyplus "B"o guards to protect the evaporator area.

### Space requirements

The ENERGYPLUS "B" units are air-cooled, hence it is important to observe the minimum distances which guarantee the best ventilation of the condenser coils. Limitations of space reducing the air flow could cause significant reductions in cooling capacity and an increase in electricity consumption.

To determinate unit placement, careful consideration must be given to assure a sufficient air flow across the condenser heat transfer surface. Two conditions must be avoided to achieve the best performance: warm air recirculation and coil starvation.

Both these conditions cause an increase of condensing pressures that results in reductions in unit efficiency and capacity. The ENERGYPLUS "B" chiller performance is less affected in poor air flow situations because of its special condensing coil geometry.

Moreover McQuay's unique microprocessor has the ability to calculate the operating environment of the chiller and the capacity to optimize its performance staying on-line during abnormal conditions.

Each side of the unit must be accessible after installation for periodic service. Fig.1 shows you minimum recommended clearance requirements.

Vertical condenser air discharge must be unobstructed because the unit would have its capacity and efficiency significantly reduced.

If the units are positioned in places surrounded by walls or obstacles of the same height as the units, the units should be at least 2500 mm from obstacles (fig.2). In the event the obstacles are higher than the units, the units should be at least 3000 mm from the obstacle (fig.4). Units installed closer than the minimum recommended distance to a wall or other vertical riser may experience a combination of coil starvation and warm air recirculation, thus causing reduction in unit capacity and efficiency reductions. Once again, the microprocessor will allow the chiller to stay on line, producing the maximum available capacity, even at less than recommended lateral clearances.

When two or more units are positioned side by side it is recommended that the condenser coils are at least 3600 mm distance from one another (fig.3); strong wind could be the cause of air warm recirculation.

For other installation solutions, consult McQuay technicians.

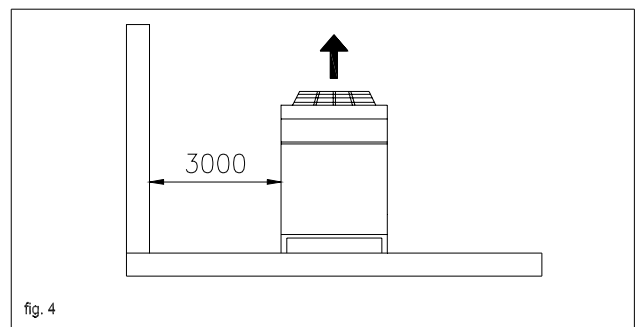
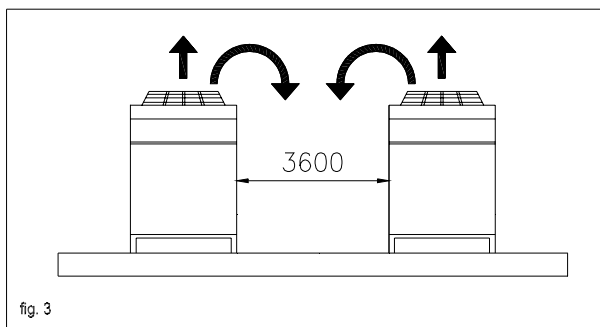
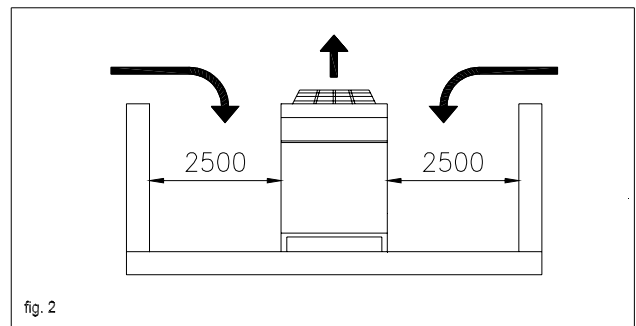
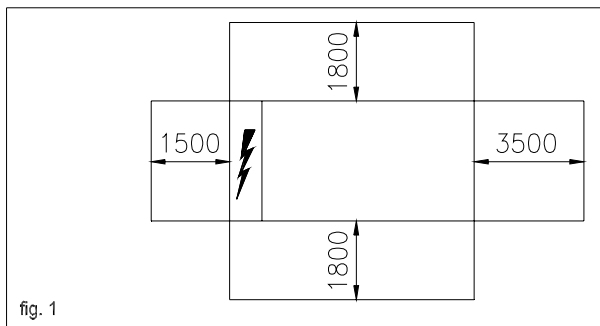

## Acoustic protection

The low noise levels of the ENERGYPLUS "B" units means that they meet the most restrictive regulations, thanks to the availability of four versions with different sound levels. When the noise level must meet special requirements it will be necessary to pay the maximum attention to ensure the perfect insulation of the unit from the support base by applying appropriate vibration-dampening devices, applying vibration-dampening mounts on the water pipes and on the electrical connections.

**Table 1 – Operating limits – ENERGYPLUS “B” SE**

Unit version		ST/CN	LN	XN	XXN
Max ambient temperature	°C	+ 45	+ 40	+ 40	+ 40
Min ambient temperature (1)	°C	+ 10	+ 5	+ 5	+ 5
Max leaving evaporator water temperature	°C	+ 10	+ 10	+ 10	+ 10
Min leaving evap. water temp.(without glycol)	°C	+ 4	+ 4	+ 4	+ 4
Min leaving evap. water temp.(with glycol)	°C	- 8	- 8	- 8	- 8
Max evaporator ΔT	°C	8	8	8	8
Min evaporator ΔT	°C	4	4	4	4

**Note:** (1) When air temperature is lower than +10°C (ST – CN) or +5°C (LN – XN – XXN) you need the fan speed control device. Speedrol allows unit running with air temperature down to –18°C; fan speed modulation or fan silent mode allows unit running with air temperature down to –10°C.

**Table 2 – Operating limits – ENERGYPLUS “B” XE**

Unit version		ST/CN	LN	XN
Max ambient temperature	°C	+ 50	+ 45	+ 45
Min ambient temperature (1)	°C	+ 10	+ 5	+ 5
Max leaving evaporator water temperature	°C	+ 10	+ 10	+ 10
Min leaving evap. water temp.(without glycol)	°C	+ 4	+ 4	+ 4
Min leaving evap. water temp.(with glycol)	°C	- 8	- 8	- 8
Max evaporator ΔT	°C	8	8	8
Min evaporator ΔT	°C	4	4	4

**Note:** (1) When air temperature is lower than +10°C (ST – CN) or +5°C (LN – XN) you need the fan speed control device. Speedrol allows unit running with air temperature down to –18°C; fan speed modulation or fan silent mode allows unit running with air temperature down to –10°C.

**Table 3 – Operating limits – ENERGYPLUS “B” HA**

Unit version		ST/CN
Max ambient temperature	°C	+ 50
Min ambient temperature	°C	+ 10
Max leaving evaporator water temperature	°C	+ 10
Min leaving evap. water temp.(without glycol)	°C	+ 4
Min leaving evap. water temp.(with glycol)	°C	- 8
Max evaporator ΔT	°C	8
Min evaporator ΔT	°C	4

**Table 4 – Evaporator fouling factors**

Fouling factors m <sup>2</sup> °C / kW	Cooling capacity correction factor	Power input correction factor	COP correction factor
0,0176	1,000	1,000	1,000
0,0440	0,978	0,986	0,992
0,0880	0,957	0,974	0,983
0,1320	0,938	0,962	0,975

**Table 5 – Altitude correction factors**

Elvation above sea level (m)	0	300	600	900	1200	1500	1800
Barometric pressure (mbar)	1013	977	942	908	875	843	812
Cooling cap.correction factor	1,000	0,993	0,986	0,979	0,973	0,967	0,960
Power input correction factor	1,000	1,005	1,009	1,015	1,021	1,026	1,031

**Table 6 – Ethylene glycol and low ambient temperature correction factors**

Air ambient temperature °C	-3	-8	-15	-23	-35
% of ethylene glycol by weight	10	20	30	40	50
Cooling capacity correction factor	0,991	0,982	0,972	0,961	0,946
Power input correction factor	0,996	0,992	0,986	0,976	0,966
Flow rate correction factor	1,013	1,040	1,074	1,121	1,178
Water pressure drops correction factor	1,070	1,129	1,181	1,263	1,308

**Table 7 – Low temperature operation performance factors**

Ethylene glycol/water leaving temperature °C	2	0	-2	-4	-6	-8
Max air ambient temperature °C (SE-ST)	40	39	38	37	36	35
Max air ambient temperature °C (XE-ST)	44	43	42	41	40	39
Cooling capacity correction factor	0,842	0,785	0,725	0,670	0,613	0,562
Power input compressors correction factor	0,95	0,94	0,92	0,89	0,87	0,84
Min. % of ethylene glycol	10	20	20	30	30	30

Low temperature operation performance factors must be applied to the nominal performance data to have the adjusted value (12/7°C, design ambient temperature).

## Nomenclature

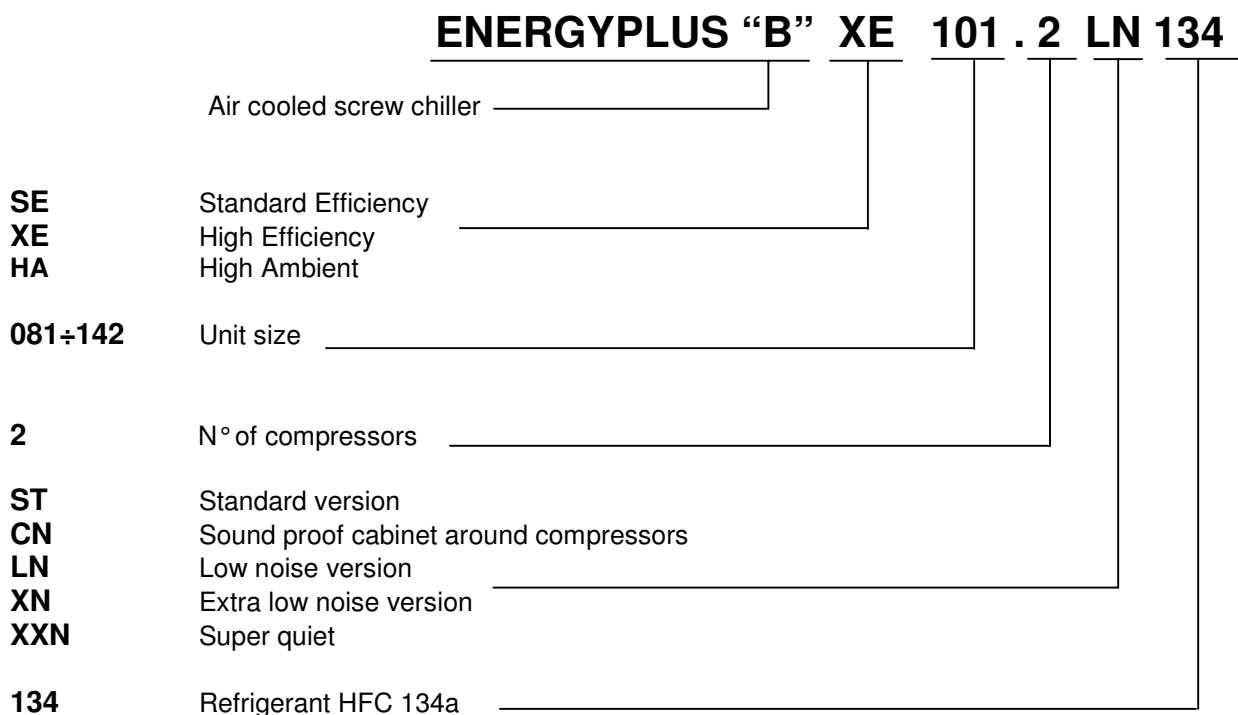

## Physical data ENERGYPLUS “B” SE ST / CN HFC 134a

ENERGYPLUS “B” Unit Size		081.2	094.2	101.2	114.2	125.2	142.2
Cooling capacity (1)	kW	301,1	347,0	370,7	408,0	452,0	524,8
Power input (1)	kW	114,6	117,5	131,1	147,2	164,4	173,4
COP		2,63	2,95	2,83	2,77	2,75	3,02
McQuay Screw compressors	No.	2	2	2	2	2	2
Refrigerant circuits	No.	2	2	2	2	2	2
Refrigerant charge HFC 134a	kg	70	75	80	85	85	90
Oil charge	l	20	20	20	20	20	20
Min % of capacity reduction	%	12,5%	12,5%	12,5%	12,5%	12,5%	12,5%

### Condenser fans

No. of fans / nominal power fan	kW	4 / 1,6	6 / 1,6	6 / 1,6	6 / 1,6	6 / 1,6	8 / 1,6
Fan speed	rpm	900	900	900	900	900	900
Diameter	mm	800	800	800	800	800	800
Total air flow	m <sup>3</sup> /s	20,2	32,1	32,1	31,2	30,2	42,8

### Evaporator

Evaporators / water volume	No./l	1 / 198	1 / 181	1 / 181	1 / 181	1 / 227	1 / 273
Max operating pressure	bar	10,5	10,5	10,5	10,5	10,5	10,5
Water connection diameter	mm	139,7	139,7	139,7	139,7	139,7	139,7

### Condenser coil

Coil type	Lanced fins – Internally spiral wound tubes						
-----------	---	--	--	--	--	--	--

### Weight and dimensions

Standard unit shipping weight	kg	3250	3515	3515	3515	3565	3895
Standard unit shipping weight ( CN )	kg	3510	3775	3775	3775	3825	4195
Standard unit operating weight	kg	3448	3696	3696	3696	3792	4168
Standard unit operating weight ( CN )	kg	3708	3956	3956	3956	4052	4468
Unit length	mm	2790	3460	3460	3460	3460	4355
Unit width	mm	2230	2230	2230	2230	2230	2230
Unit height	mm	2520	2520	2520	2520	2520	2520

Note: (1) Nominal cooling capacity and power input are based on: 12/7 °C entering/leaving evaporator water temperature; 35°C ambient temperature. The power input is for compressor only.

## Electrical data ENERGYPLUS “B” SE ST / CN HFC 134a

ENERGYPLUS “B” Unit Size		081.2	094.2	101.2	114.2	125.2	142.2
Standard voltage (1)		400 V – 3ph – 50 Hz					
Nominal unit current (2)	A	201	205	223	247	270	285
Max compressor current (3)	A	241	247	273	304	335	369
Fans current	A	16	24	24	24	24	32
Max unit current (3)	A	257	271	297	328	349	401
Max unit inrush current (4)	A	405	413	424	424	447	463
Max unit current for wires sizing (5)	A	264	295	318	336	354	428

- Notes: (1) Allowed voltage tolerance  $\pm 10\%$ . Voltage unbalance between phases must be within  $\pm 3\%$ .  
(2) Nominal current are based on: 12/7 °C entering/leaving evaporator water temperature and 35°C ambient temp.  
(3) Maximum current are based on: 15/10 °C entering/leaving evaporator water temperature and 45°C ambient temp.  
(4) Inrush current of biggest compressor + 75% of nominal absorbed current of the other compressor (see pag. 4 “Intelligent Start Compressor Mode”) + fans current.  
(5) Compressor FLA + fans current.

## Physical data ENERGYPLUS “B” SE LN / XN HFC 134a

ENERGYPLUS “B” Unit Size		081.2	094.2	101.2	114.2	125.2	142.2
Cooling capacity (1)	kW	287,4	337,3	359,4	402,7	433,2	512,6
Power input (1)	kW	123,0	123,7	138,6	158,8	176,5	186,1
COP		2,34	2,73	2,59	2,54	2,45	2,75
McQuay Screw compressors	No.	2	2	2	2	2	2
Refrigerant circuits	No.	2	2	2	2	2	2
Refrigerant charge HFC 134a	kg	70	75	80	85	85	90
Oil charge	l	20	20	20	20	20	20
Min % of capacity reduction	%	12.5%	12.5%	12.5%	12.5%	12.5%	12,5%

### Condenser fans

No. of fans / nominal power fan	kW	4 / 1	6 / 1	6 / 1	6 / 1	6 / 1	8 / 1
Fan speed	rpm	700	700	700	700	700	700
Diameter	mm	800	800	800	800	800	800
Total air flow	m <sup>3</sup> /s	15	23,7	23,7	23,1	24,5	31,7

### Evaporator

Evaporators / water volume	No./l	1 / 198	1 / 181	1 / 181	1 / 181	1 / 227	1 / 273
Max operating pressure	bar	10,5	10,5	10,5	10,5	10,5	10,5
Water connection diameter	mm	139,7	139,7	139,7	139,7	139,7	139,7

### Condenser coil

Coil type	Lanced fins – Internally spiral wound tubes						
-----------	---	--	--	--	--	--	--

### Weight and dimensions

Standard unit shipping weight	kg	3250	3515	3515	3515	3565	3895
Standard unit shipping weight ( XN )	kg	3510	3775	3775	3775	3825	4195
Standard unit operating weight	kg	3448	3696	3696	3696	3792	4168
Standard unit operating weight ( XN )	kg	3708	3956	3956	3956	4052	4468
Unit length	mm	2790	3460	3460	3460	3460	4355
Unit width	mm	2230	2230	2230	2230	2230	2230
Unit height	mm	2520	2520	2520	2520	2520	2520

**Note:** (1) Nominal cooling capacity and power input are based on: 12/7 °C entering/leaving evaporator water temperature; 35°C ambient temperature. The power input is for compressor only.

## Electrical data ENERGYPLUS “B” SE LN / XN HFC 134a

ENERGYPLUS “B” Unit Size		081.2	094.2	101.2	114.2	125.2	142.2
Standard voltage (1)		400 V – 3ph – 50 Hz					
Nominal unit current (2)	A	212	213	234	262	288	304
Max compressor current (3)	A	237	239	264	297	328	354
Fans current	A	9	14	14	14	14	18
Max unit current (3)	A	246	252	277	311	342	372
Max unit inrush current (4)	A	403	408	419	419	446	458
Max unit current for wires sizing (5)	A	257	285	308	326	344	414

**Notes:** (1) Allowed voltage tolerance  $\pm 10\%$ . Voltage unbalance between phases must be within  $\pm 3\%$ .

(2) Nominal current are based on: 12/7 °C entering/leaving evaporator water temperature and 35°C ambient temp.

(3) Maximum current are based on: 15/10 °C entering/leaving evaporator water temperature and 40°C ambient temp.

(4) Inrush current of biggest compressor + 75% of nominal absorbed current of the other compressor (see pag. 4 “Intelligent Start Compressor Mode”) + fans current.

(5) Compressor FLA + fans current.

## Physical data ENERGYPLUS “B” SE XXN HFC 134a

ENERGYPLUS “B” Unit Size		081.2	094.2	101.2	114.2	125.2	142.2
Cooling capacity (1)	kW	294,1	330,7	363,3	409,5	447,8	516,9
Power input (1)	kW	118,6	127,7	136,0	149,4	161,5	189,0
COP		2,48	2,59	2,67	2,74	2,77	2,74
McQuay Screw compressors	No.	2	2	2	2	2	2
Refrigerant circuits	No.	2	2	2	2	2	2
Refrigerant charge HFC 134a	kg	80	85	90	95	100	110
Oil charge	l	20	20	20	20	20	20
Min % of capacity reduction	%	12.5%	12.5%	12.5%	12.5%	12.5%	12,5%

### Condenser fans

No. of fans / nominal power fan	kW	6 / 0,74	7 / 0,74	8 / 0,74	9 / 0,74	10 / 0,74	10 / 0,74
Fan speed	rpm	500	500	500	500	500	500
Diameter	mm	800	800	800	800	800	800
Total air flow	m <sup>3</sup> /s	23,7	27,7	31,7	35,6	39,6	39,6

### Evaporator

Evaporators / water volume	No./l	1 / 192	1 / 192	1 / 190	1 / 225	1 / 221	1 / 265
Max operating pressure	bar	10,5	10,5	10,5	10,5	10,5	10,5
Water connection diameter	mm	139,7	139,7	139,7	139,7	139,7	139,7

### Condenser coil

Coil type	Lanced fins – Internally spiral wound tubes						
-----------	---	--	--	--	--	--	--

### Weight and dimensions

Standard unit shipping weight	kg	3720	4000	4110	4335	4435	4535
Standard unit operating weight	kg	3912	4192	4300	4560	4656	4800
Unit length	mm	3460	4355	4355	5255	5255	5255
Unit width	mm	2230	2230	2230	2230	2230	2230
Unit height	mm	2520	2520	2520	2520	2520	2520

**Note:** (1) Nominal cooling capacity and power input are based on: 12/7 °C entering/leaving evaporator water temperature; 35°C ambient temperature. The power input is for compressor only.

## Electrical data ENERGYPLUS “B” SE XXN HFC 134a

ENERGYPLUS “B” Unit Size		081.2	094.2	101.2	114.2	125.2	142.2
Standard voltage (1)		400 V – 3ph – 50 Hz					
Nominal unit current (2)	A	207	220	232	255	274	309
Max compressor current (3)	A	231	247	261	288	310	361
Fans current	A	9	11	12	14	15	15
Max unit current (3)	A	240	257	273	301	325	376
Max unit inrush current (4)	A	401	403	416	418	440	458
Max unit current for wires sizing (5)	A	257	282	306	326	345	411

**Notes:** (1) Allowed voltage tolerance  $\pm 10\%$ . Voltage unbalance between phases must be within  $\pm 3\%$ .

(2) Nominal current are based on: 12/7 °C entering/leaving evaporator water temperature and 35°C ambient temp.

(3) Maximum current are based on: 15/10 °C entering/leaving evaporator water temperature and 40°C ambient temp.

(4) Inrush current of biggest compressor + 75% of nominal absorbed current of the other compressor (see pag. 4 “Intelligent Start Compressor Mode”) + fans current.

(5) Compressor FLA + fans current.

## Physical data ENERGYPLUS “B” XE ST / CN HFC 134a

ENERGYPLUS “B” Unit Size		081.2	094.2	101.2	114.2	125.2	142.2
Cooling capacity (1)	kW	323,2	366,0	392,6	456,4	491,6	546,2
Power input (1)	kW	103,8	115,4	128,8	135,1	150,5	158,7
COP		3,11	3,17	3,05	3,38	3,27	3,44
McQuay Screw compressors	No.	2	2	2	2	2	2
Refrigerant circuits	No.	2	2	2	2	2	2
Refrigerant charge HFC 134a	kg	70	80	80	85	90	100
Oil charge	l	20	20	20	20	20	20
Min % of capacity reduction	%	12,5%	12,5%	12,5%	12,5%	12,5%	12,5%

### Condenser fans

No. of fans / nominal power fan	kW	6 / 1,6	6 / 1,6	6 / 1,6	8 / 1,6	8 / 1,6	10 / 1,6
Fan speed	rpm	900	900	900	900	900	900
Diameter	mm	800	800	800	800	800	800
Total air flow	m <sup>3</sup> /s	33,2	31,6	31,6	44,2	44,2	52,8

### Evaporator

Evaporators / water volume	No./l	1 / 181	1 / 227	1 / 227	1 / 205	1 / 205	1 / 265
Max operating pressure	bar	10,5	10,5	10,5	10,5	10,5	10,5
Water connection diameter	mm	139,7	139,7	139,7	139,7	139,7	139,7

### Condenser coil

Coil type	Lanced fins – Internally spiral wound tubes						
-----------	---	--	--	--	--	--	--

### Weight and dimensions

Standard unit shipping weight	kg	3515	3565	3565	3855	3855	4235
Standard unit shipping weight ( CN )	kg	3775	3825	3825	4155	4155	4535
Standard unit operating weight	kg	3696	3792	3792	4060	4060	4500
Standard unit operating weight ( CN )	kg	3956	4052	4052	4360	4360	4800
Unit length	mm	3460	3460	3460	4355	4355	5255
Unit width	mm	2230	2230	2230	2230	2230	2230
Unit height	mm	2520	2520	2520	2520	2520	2520

**Note:** (1) Nominal cooling capacity and power input are based on: 12/7 °C entering/leaving evaporator water temperature; 35°C ambient temperature. The power input is for compressor only.

## Electrical data ENERGYPLUS “B” XE ST / CN HFC 134a

ENERGYPLUS “B” Unit Size		081.2	094.2	101.2	114.2	125.2	142.2
Standard voltage (1)		400 V – 3ph – 50 Hz					
Nominal unit current (2)	A	186	202	219	235	259	262
Max compressor current (3)	A	239	262	290	313	348	378
Fans current	A	24	24	24	32	32	40
Max unit current (3)	A	263	286	314	339	357	418
Max unit inrush current (4)	A	405	405	422	430	450	459
Max unit current for wires sizing (5)	A	272	295	318	344	362	436

**Notes:** (1) Allowed voltage tolerance ± 10%. Voltage unbalance between phases must be within ± 3%.

(2) Nominal current are based on: 12/7 °C entering/leaving evaporator water temperature and 35°C ambient temp.

(3) Maximum current are based on: 15/10 °C entering/leaving evaporator water temperature and 50°C ambient temp.

(4) Inrush current of biggest compressor + 75% of nominal absorbed current of the other compressor (see pag. 4 “Intelligent Start Compressor Mode”) + fans current.

(5) Compressor FLA + fans current.



## Physical data ENERGYPLUS “B” XE LN / XN HFC 134a

ENERGYPLUS “B” Unit Size		081.2	094.2	101.2	114.2	125.2	142.2
Cooling capacity (1)	kW	315,1	354,8	379,5	444,9	478,2	537,1
Power input (1)	kW	108,7	122,0	136,6	141,5	158,3	168,1
COP		2,90	2,91	2,78	3,14	3,02	3,19
McQuay Screw compressors	No.	2	2	2	2	2	2
Refrigerant circuits	No.	2	2	2	2	2	2
Refrigerant charge HFC 134a	kg	70	80	80	85	90	100
Oil charge	l	20	20	20	20	20	20
Min % of capacity reduction	%	12,5%	12,5%	12,5%	12,5%	12,5%	12,5%

### Condenser fans

No. of fans / nominal power fan	kW	6 / 1	6 / 1	6 / 1	8 / 1	8 / 1	10 / 1
Fan speed	rpm	700	700	700	700	700	700
Diameter	mm	800	800	800	800	800	800
Total air flow	m <sup>3</sup> /s	23,7	22,5	22,5	31,7	31,7	39,6

### Evaporator

Evaporators / water volume	No./l	1 / 181	1 / 227	1 / 227	1 / 205	1 / 205	1 / 265
Max operating pressure	bar	10,5	10,5	10,5	10,5	10,5	10,5
Water connection diameter	mm	139,7	139,7	139,7	139,7	139,7	139,7

### Condenser coil

Coil type	Lanced fins – Internally spiral wound tubes						
-----------	---	--	--	--	--	--	--

### Weight and dimensions

Standard unit shipping weight	kg	3515	3565	3565	3855	3855	4235
Standard unit shipping weight ( XN )	kg	3775	3825	3825	4155	4155	4535
Standard unit operating weight	kg	3696	3792	3792	4060	4060	4500
Standard unit operating weight ( XN )	kg	3956	4052	4052	4360	4360	4800
Unit length	mm	3460	3460	3460	4355	4355	5255
Unit width	mm	2230	2230	2230	2230	2230	2230
Unit height	mm	2520	2520	2520	2520	2520	2520

**Note:** (1) Nominal cooling capacity and power input are based on: 12/7 °C entering/leaving evaporator water temperature; 35°C ambient temperature. The power input is for compressor only.

## Electrical data ENERGYPLUS “B” XE LN / XN HFC 134a

ENERGYPLUS “B” Unit Size		081.2	094.2	101.2	114.2	125.2	142.2
Standard voltage (1)		400 V – 3ph – 50 Hz					
Nominal unit current (2)	A	193	211	230	245	271	277
Max compressor current (3)	A	230	254	282	300	335	357
Fans current	A	14	14	14	18	18	23
Max unit current (3)	A	244	268	296	319	343	380
Max unit inrush current (4)	A	399	399	417	421	442	450
Max unit current for wires sizing (5)	A	262	285	308	330	348	419

**Notes:** (1) Allowed voltage tolerance  $\pm 10\%$ . Voltage unbalance between phases must be within  $\pm 3\%$ .

(2) Nominal current are based on: 12/7 °C entering/leaving evaporator water temperature and 35°C ambient temp.

(3) Maximum current are based on: 15/10 °C entering/leaving evaporator water temperature and 45°C ambient temp.

(4) Inrush current of biggest compressor + 75% of nominal absorbed current of the other compressor (see pag. 4 “Intelligent Start Compressor Mode”) + fans current.

(5) Compressor FLA + fans current.

## Physical data ENERGYPLUS “B” HA HFC 134a

ENERGYPLUS “B” Unit Size		081.2	094.2	101.2	114.2	125.2	142.2
Cooling capacity (1)	kW	318,3	353,1	378,0	444,2	477,5	539,6
Power input (1)	kW	103,0	113,6	126,6	133,5	148,6	158,0
COP		3,09	3,11	2,99	3,33	3,21	3,42
McQuay Screw compressors	No.	2	2	2	2	2	2
Refrigerant circuits	No.	2	2	2	2	2	2
Refrigerant charge HFC 134a	kg	70	80	80	85	90	100
Oil charge	l	20	20	20	20	20	20
Min % of capacity reduction	%	12,5%	12,5%	12,5%	12,5%	12,5%	12,5%

### Condenser fans

No. of fans / nominal power fan	kW	6 / 1,6	6 / 1,6	6 / 1,6	8 / 1,6	8 / 1,6	10 / 1,6
Fan speed	rpm	900	900	900	900	900	900
Diameter	mm	800	800	800	800	800	800
Total air flow	m <sup>3</sup> /s	33,2	31,6	31,6	44	44	55,3

### Evaporator

Evaporators / water volume	No./l	1 / 181	1 / 227	1 / 227	1 / 205	1 / 205	1 / 265
Max operating pressure	bar	10,5	10,5	10,5	10,5	10,5	10,5
Water connection diameter	mm	139,7	139,7	139,7	139,7	139,7	139,7

### Condenser coil

Coil type	Lanced fins – Internally spiral wound tubes						
-----------	---	--	--	--	--	--	--

### Weight and dimensions

Standard unit shipping weight	kg	3515	3565	3565	3855	3855	4235
Standard unit operating weight	kg	3696	3792	3792	4060	4060	4500
Unit length	mm	3460	3460	3460	4355	4355	5255
Unit width	mm	2230	2230	2230	2230	2230	2230
Unit height	mm	2520	2520	2520	2520	2520	2520

**Note:** (1) Nominal cooling capacity and power input are based on: 12/7 °C entering/leaving evaporator water temperature; 35 °C ambient temperature. The power input is for compressor only.

## Electrical data ENERGYPLUS “B” HA HFC 134a

ENERGYPLUS “B” Unit Size		081.2	094.2	101.2	114.2	125.2	142.2
Standard voltage (1)		400 V – 3ph – 50 Hz					
Nominal unit current (2)	A	186	200	217	232	255	261
Max compressor current (3)	A	238	261	288	310	344	376
Fans current	A	24	24	24	32	32	40
Max unit current (3)	A	262	285	312	342	357	416
Max unit inrush current (4)	A	405	405	421	429	448	459
Max unit current for wires sizing (5)	A	272	295	318	344	362	436

**Notes:** (1) Allowed voltage tolerance  $\pm 10\%$ . Voltage unbalance between phases must be within  $\pm 3\%$ .

(2) Nominal current are based on: 12/7 °C entering/leaving evaporator water temperature and 35 °C ambient temp.

(3) Maximum current are based on: 15/10 °C entering/leaving evaporator water temperature and 50 °C ambient temp.

(4) Inrush current of biggest compressor + 75% of nominal absorbed current of the other compressor (see pag. 4 “Intelligent Start Compressor Mode”) + fans current.

(5) Compressor FLA + fans current.

## Sound pressure level ENERGYPLUS “B” SE, XE, HA ST

Energyplus “B” Unit size	Sound pressure level at 1 m from the unit in free field (rif. $2 \times 10^{-5}$ Pa)								
	63 Hz	125 Hz	250 Hz	500 Hz	1000 Hz	2000 Hz	4000 Hz	8000 Hz	dBA
081.2	64,8	73,6	71,7	78,6	71,5	73,0	60,2	52,0	79,0
094.2	65,0	73,8	71,8	78,5	71,6	73,1	60,5	51,8	79,0
101.2	64,9	73,7	71,9	78,8	71,3	72,9	60,6	52,5	79,0
114.2	65,2	74,0	72,0	79,3	71,7	73,3	60,9	53,0	79,5
125.2	66,0	74,5	72,8	79,8	71,9	73,9	61,8	54,0	80,0
142.2	65,8	74,4	73,0	79,7	72,0	74,0	61,9	54,5	80,0

## Sound pressure level ENERGYPLUS “B” SE, XE, HA CN

Energyplus “B” Unit size	Sound pressure level at 1 m from the unit in free field (rif. $2 \times 10^{-5}$ Pa)								
	63 Hz	125 Hz	250 Hz	500 Hz	1000 Hz	2000 Hz	4000 Hz	8000 Hz	dBA
081.2	62,8	71,6	71,1	76,8	68,8	70,9	58,2	50,0	77,0
094.2	62,5	71,7	71,3	76,7	68,9	71,0	58,0	50,8	77,0
101.2	62,9	71,9	70,5	77,0	68,5	70,8	58,5	50,4	77,0
114.2	63,0	72,1	71,6	77,1	69,8	71,5	58,6	51,5	77,5
125.2	63,4	72,3	72,2	77,9	70,2	71,5	58,9	51,0	78,0
142.2	63,5	72,5	72,5	77,5	70,6	71,8	59,2	52,1	78,0

## Sound pressure level ENERGYPLUS “B” SE, XE, LN

Energyplus “B” Unit size	Sound pressure level at 1 m from the unit in free field (rif. $2 \times 10^{-5}$ Pa)								
	63 Hz	125 Hz	250 Hz	500 Hz	1000 Hz	2000 Hz	4000 Hz	8000 Hz	dBA
081.2	55,8	66,2	67,0	74,8	66,4	69,4	54,7	46,3	75,0
094.2	56,0	66,7	67,5	75,1	66,8	70,1	55,0	46,7	75,5
101.2	56,2	66,9	67,4	75,0	66,9	70,2	55,1	47,0	75,5
114.2	56,3	66,5	67,5	75,2	66,5	70,3	55,0	47,1	75,5
125.2	56,5	66,9	67,9	75,7	67,0	70,6	55,5	47,5	76,0
142.2	56,8	70,0	67,7	75,5	67,3	70,7	55,7	48,0	76,0

## Sound pressure level ENERGYPLUS “B” SE, XE, XN

Energyplus “B” Unit size	Sound pressure level at 1 m from the unit in free field (rif. $2 \times 10^{-5}$ Pa)								
	63 Hz	125 Hz	250 Hz	500 Hz	1000 Hz	2000 Hz	4000 Hz	8000 Hz	dBA
081.2	56,4	69,6	69,5	70,5	65,6	61,4	54,1	43,8	71,0
094.2	56,4	69,6	69,0	71,0	65,2	61,2	53,8	43,8	71,0
101.2	56,8	70,0	69,5	71,5	65,6	61,5	54,0	44,0	71,5
114.2	56,5	70,5	69,5	71,5	65,6	61,7	54,5	45,0	71,5
125.2	56,5	70,0	69,1	71,8	65,4	61,3	54,6	45,5	71,5
142.2	57,0	71,0	69,6	72,2	65,9	61,5	55,0	45,6	72,0

## Sound pressure level ENERGYPLUS “B” SE XXN

Energyplus “B” Unit size	Sound pressure level at 1 m from the unit in free field (rif. $2 \times 10^{-5}$ Pa)								
	63 Hz	125 Hz	250 Hz	500 Hz	1000 Hz	2000 Hz	4000 Hz	8000 Hz	dBA
081.2	62,0	60,1	63,5	62,8	59,9	58,1	46,9	36,5	65,0
094.2	62,5	59,5	64,0	62,5	59,2	58,7	49,0	39,0	65,0
101.2	62,5	59,5	63,5	62,3	60,4	58,5	46,4	36,0	65,0
114.2	62,0	60,1	63,5	62,8	59,9	58,1	46,9	36,5	65,0
125.2	63,0	59,0	63,0	62,0	60,0	59,0	46,0	36,5	65,0
142.2	61,0	58,0	63,0	64,0	58,5	58,0	49,5	38,6	65,0

**Note:** Average sound pressure level rated in accordance to ISO 3744, free field semispheric conditions.

**Note:** Sound pressure levels are referred to ENERGYPLUS “B” Units furnished without water pump.

**Sound pressure level correction factor for different distances ENERGYPLUS “B” SE ST, CN, LN, XN**

ENERGYPLUS S “B” Unit size	Distance (m)					
	1	5	10	15	20	25
081.2	0	8,0	12,9	16,0	18,3	20,1
094.2	0	7,8	12,6	15,7	18,0	19,8
101.2	0	7,8	12,6	15,7	18,0	19,8
114.2	0	7,8	12,6	15,7	18,0	19,8
125.2	0	7,8	12,6	15,7	18,0	19,8
142.2	0	7,6	12,3	15,3	17,6	19,4

**Sound pressure level correction factor for different distances ENERGYPLUS “B” XE ST, CN, LN, XN; ENERGYPLUS “B” HA ST, CN**

ENERGYPLUS S “B” Unit size	Distance (m)					
	1	5	10	15	20	25
081.2	0	7,8	12,6	15,7	18,0	19,8
094.2	0	7,6	12,3	15,3	17,6	19,4
101.2	0	7,6	12,3	15,3	17,6	19,4
114.2	0	7,3	12,0	15,0	17,2	19,0
125.2	0	7,3	12,0	15,0	17,2	19,0
142.2	0	7,3	12,0	15,0	17,2	19,0

**Correction factor for different distances ENERGYPLUS “B” SE XXN**

ENERGYPLUS S “B” Unit size	Distance (m)					
	1	5	10	15	20	25
081.2	0	7,8	12,6	15,7	18,0	19,8
094.2	0	7,8	12,6	15,7	18,0	19,8
101.2	0	7,8	12,6	15,7	18,0	19,8
114.2	0	7,6	12,3	15,3	17,6	19,4
125.2	0	7,6	12,3	15,3	17,6	19,4
142.2	0	7,3	12,0	15,0	17,2	19,0

**Note:** The values reported in tables must be subtracted to those declared at 1 meter in free field semispheric conditions.

## Standard ratings ENERGYPLUS “B” SE 081.2 ÷ 142.2 ST, CN

Unit size	Evaporator leaving water temp. (°C)	AIR AMBIENT TEMPERATURE - °C									
		25		30		35		40		45	
		Cooling capacity (kW)	Power input (kW)	Cooling capacity (kW)	Power input (kW)	Cooling capacity (kW)	Power input (kW)	Cooling capacity (kW)	Power input (kW)	Cooling capacity (kW)	Power input (kW)
081.2	4	304,6	90,4	290,2	99,7	275,1	109,9	259,1	121,2	242,1	133,7
	5	313,4	91,8	298,7	101,2	283,3	111,4	267,0	122,7	249,6	135,2
	6	322,5	93,3	307,4	102,7	291,7	113,0	275,0	124,3	257,3	136,7
	7	331,6	94,8	316,3	104,3	301,1	114,6	283,1	125,9	265,0	138,4
	8	340,8	96,4	325,2	105,9	308,7	116,2	291,3	127,6	272,8	140,1
	9	350,3	98,0	334,2	107,5	317,4	117,9	299,6	129,3	280,8	141,8
	10	359,7	99,6	343,4	109,2	326,1	119,7	308,1	131,1	288,9	143,6
094.2	4	349,3	92,7	333,7	102,4	317,3	112,9	300,2	124,6	282,1	137,5
	5	359,7	94,1	343,8	103,8	327,1	114,4	309,5	126,1	291,2	139,0
	6	370,3	95,5	354,1	105,3	336,9	115,9	319,1	127,6	300,3	140,5
	7	381,2	97,0	364,5	106,8	347,0	117,5	328,8	129,2	309,5	142,1
	8	392,0	98,5	375,0	108,3	357,2	119,0	338,5	130,8	318,9	143,7
	9	403,1	100,0	385,7	109,9	367,5	120,7	348,5	132,5	328,4	145,4
	10	414,3	101,5	396,5	111,5	378,0	122,3	358,6	134,2	338,1	147,1
101.2	4	374,3	103,4	357,3	114,2	339,6	126,0	321,0	139,1	301,4	153,6
	5	385,2	105,0	367,9	115,8	349,9	127,7	330,9	140,8	310,9	155,3
	6	396,5	106,6	378,7	117,5	360,3	129,4	340,8	142,5	320,5	157,0
	7	407,7	108,3	389,7	119,2	370,7	131,2	351,0	144,3	330,2	158,8
	8	419,3	110,0	400,8	121,0	381,5	133,0	361,3	146,1	340,1	160,6
	9	430,8	111,7	411,9	122,7	392,3	134,8	371,7	148,0	350,1	162,5
	10	442,6	113,5	423,4	124,6	403,2	136,7	382,2	149,9	360,2	164,4
114.2	4	412,9	116,0	393,9	128,0	374,0	141,3	353,1	156,1	331,2	172,5
	5	424,8	117,8	405,5	129,9	385,1	143,2	363,9	158,0	341,6	174,3
	6	437,0	119,6	417,3	131,8	396,6	145,1	374,9	159,9	352,0	176,3
	7	449,4	121,5	429,1	133,7	408,0	147,1	385,9	161,9	362,6	178,3
	8	461,9	123,4	441,3	135,7	419,7	149,2	397,1	164,0	373,4	180,3
	9	474,6	125,4	453,5	137,7	431,6	151,3	408,5	166,1	384,2	182,5
	10	487,4	127,4	465,9	139,8	443,4	153,4	419,9	168,3	395,2	184,6
125.2	4	458,3	129,7	436,8	143,0	414,2	157,7	390,5	174,0	365,6	192,2
	5	471,8	131,7	449,7	145,1	426,6	159,9	402,5	176,2	377,1	194,4
	6	485,3	133,9	462,7	147,3	439,2	162,1	414,5	178,4	388,6	196,6
	7	499,0	136,1	476,0	149,5	452,0	164,4	426,8	180,8	400,3	198,9
	8	512,9	138,3	489,4	151,9	464,9	166,7	439,2	183,1	412,1	201,2
	9	526,9	140,6	503,0	154,2	478,0	169,2	451,7	185,6	424,2	203,7
	10	541,2	143,0	516,7	156,6	491,2	171,6	464,4	188,1	436,3	206,2
142.2	4	519,3	129,5	499,8	148,1	481,6	167,5	462,3	188,4	439,2	210,9
	5	533,5	131,9	514,2	150,1	496,0	169,4	476,3	190,4	452,4	213,4
	6	547,8	134,2	528,8	152,1	510,4	171,4	490,2	192,6	465,9	216,0
	7	562,3	136,6	543,4	154,1	524,8	173,4	504,4	194,8	479,3	218,7
	8	576,9	138,9	558,3	156,2	539,8	175,4	518,9	197,1	493,1	221,6
	9	591,8	141,3	573,4	158,3	554,8	177,6	533,6	199,6	507,2	224,6
	10	607,0	143,7	588,9	160,6	570,3	179,9	548,6	202,2	521,5	227,9

**Note:** The power input is for compressor only; cooling cap. and power input referred to evap. fouling factor=0,0176m<sup>2</sup> °C/kW.

## Standard ratings ENERGYPLUS "B" SE 081.2 ÷ 142.2 LN, XN

Unit size	Evaporator leaving water temp. (°C)	AIR AMBIENT TEMPERATURE - °C							
		25		30		35		40	
		Cooling capacity (kW)	Power input (kW)	Cooling capacity (kW)	Power input (kW)	Cooling capacity (kW)	Power input (kW)	Cooling capacity (kW)	Power input (kW)
081.2	4	294,3	97,0	279,5	106,8	264,0	117,7	247,4	129,7
	5	302,7	98,6	287,6	108,5	271,6	119,4	254,7	131,5
	6	311,2	100,3	295,8	110,3	279,5	121,2	262,2	133,3
	7	319,8	102,1	304,0	112,1	287,4	123,0	269,6	135,1
	8	328,4	103,8	312,4	113,9	295,4	124,9	277,3	137,0
	9	337,3	105,7	320,8	115,8	303,5	126,9	285,0	139,0
	10	346,2	107,6	329,3	117,8	311,5	128,9	292,7	141,0
094.2	4	341,4	97,6	325,5	107,6	308,8	118,7	291,4	130,9
	5	351,4	99,1	335,2	109,2	318,2	120,3	300,3	132,5
	6	361,6	100,7	345,0	110,8	327,6	122,0	309,4	134,2
	7	371,9	102,3	355,0	112,5	337,3	123,7	318,6	135,9
	8	382,4	104,0	365,1	114,2	346,9	125,4	327,9	137,7
	9	393,0	105,7	375,3	116,0	356,8	127,2	337,4	139,6
	10	403,7	107,4	385,7	117,8	366,8	129,1	346,9	141,4
101.2	4	365,0	109,2	347,8	120,5	329,6	132,9	310,6	146,7
	5	375,6	111,0	357,9	122,3	339,5	134,8	320,0	148,5
	6	386,3	112,8	368,2	124,2	349,3	136,7	329,6	150,4
	7	397,1	114,7	378,6	126,1	359,4	138,6	339,3	152,4
	8	408,0	116,6	389,2	128,0	369,6	140,6	348,9	154,4
	9	419,2	118,5	399,9	130,0	379,9	142,7	358,8	156,5
	10	430,4	120,5	410,8	132,1	390,3	144,8	368,8	158,7
114.2	4	410,8	125,2	390,5	137,9	369,3	151,9	347,0	167,5
	5	422,7	127,4	401,9	140,1	380,3	154,2	357,5	169,7
	6	434,8	129,6	413,6	142,4	391,4	156,4	368,1	172,0
	7	447,0	131,8	425,4	144,7	402,7	158,8	378,9	174,4
	8	459,4	134,1	437,2	147,0	414,1	161,2	389,9	176,8
	9	471,8	136,5	449,2	149,5	425,6	163,7	400,9	179,3
	10	484,5	138,9	461,4	151,9	437,2	166,2	412,0	181,9
125.2	4	443,1	139,0	421,1	153,2	397,8	168,9	373,5	186,3
	5	455,7	141,4	433,2	155,6	409,5	171,3	384,7	188,8
	6	468,5	143,8	445,5	158,1	421,4	173,9	396,0	191,3
	7	481,4	146,3	457,9	160,6	433,2	176,5	407,4	193,9
	8	494,6	148,9	470,5	163,3	445,3	179,1	418,8	196,6
	9	507,7	151,5	483,2	166,0	457,5	181,9	430,5	199,4
	10	521,1	154,2	496,0	168,7	469,8	184,7	442,3	202,3
142.2	4	508,0	139,9	489,5	158,9	471,0	179,2	449,8	201,0
	5	522,1	142,3	503,7	161,1	484,9	181,4	463,1	203,6
	6	536,2	144,7	518,0	163,3	498,8	183,7	476,4	206,3
	7	550,6	147,0	532,2	165,6	512,6	186,1	489,8	209,1
	8	565,1	149,4	546,8	167,9	527,1	188,7	503,5	212,1
	9	580,0	151,9	561,8	170,3	541,7	191,3	517,3	215,3
	10	595,1	154,4	577,0	172,9	556,6	194,2	531,6	218,7

**Note:** The power input is for compressor only; cooling cap. and power input referred to evap. fouling factor=0,0176m<sup>2</sup> °C/kW.

## Standard ratings ENERGYPLUS “B” SE 081.2 ÷ 142.2 XXN

Unit size	Evaporator leaving water temp. (°C)	AIR AMBIENT TEMPERATURE - °C							
		25		30		35		40	
		Cooling capacity (kW)	Power input (kW)	Cooling capacity (kW)	Power input (kW)	Cooling capacity (kW)	Power input (kW)	Cooling capacity (kW)	Power input (kW)
081.2	4	299,7	93,5	285,2	103,0	269,9	113,5	253,6	125,2
	5	308,4	95,0	293,5	104,6	277,8	115,2	261,2	126,8
	6	317,1	96,6	301,9	106,2	285,9	116,8	268,9	128,5
	7	326,0	98,2	310,5	107,9	294,1	118,5	276,8	130,2
	8	335,1	99,9	319,1	109,6	302,4	120,3	284,7	132,0
	9	344,1	101,6	327,9	111,4	310,8	122,1	292,7	133,8
	10	353,3	103,4	336,7	113,2	319,3	124,0	300,8	135,7
094.2	4	336,1	100,7	320,0	111,0	303,1	122,4	285,4	134,9
	5	345,9	102,4	329,5	112,7	312,3	124,1	294,1	136,7
	6	355,8	104,1	339,0	114,5	321,4	125,9	302,9	138,5
	7	365,8	105,8	348,7	116,3	330,7	127,7	311,7	140,3
	8	376,0	107,6	358,5	118,1	340,1	129,6	320,8	142,2
	9	386,3	109,4	368,4	120,0	349,7	131,5	329,9	144,2
	10	396,7	111,2	378,4	121,9	359,3	133,5	339,2	146,2
101.2	4	368,2	107,2	351,0	118,3	333,1	130,5	314,2	144,0
	5	378,9	108,9	361,4	120,1	343,0	132,3	323,7	145,8
	6	389,8	110,7	371,8	121,9	353,1	134,2	333,5	147,7
	7	400,8	112,5	382,4	123,7	363,3	136,0	343,2	149,6
	8	411,9	114,3	393,2	125,6	373,7	138,0	353,2	151,6
	9	423,2	116,1	404,0	127,5	384,1	139,9	363,2	153,6
	10	434,5	118,0	415,1	129,5	394,7	142,0	373,4	155,6
114.2	4	414,8	118,0	395,2	130,0	374,8	143,3	353,5	158,0
	5	427,0	119,9	407,1	132,0	386,2	145,3	364,4	160,0
	6	439,4	121,8	419,1	134,0	397,8	147,3	375,5	162,0
	7	452,0	123,8	431,2	136,0	409,5	149,4	386,7	164,1
	8	464,8	125,9	443,5	138,2	421,3	151,6	398,1	166,3
	9	477,7	128,0	456,0	140,3	433,3	153,8	409,6	168,6
	10	490,8	130,1	468,6	142,5	445,4	156,1	421,2	170,9
125.2	4	453,3	127,4	432,2	140,5	410,2	155,0	387,1	171,1
	5	466,6	129,5	445,1	142,6	422,6	157,1	399,0	173,2
	6	480,0	131,5	458,1	144,7	435,1	159,3	411,1	175,4
	7	493,7	133,6	471,3	146,9	447,8	161,5	423,3	177,6
	8	507,5	135,8	484,6	149,1	460,7	163,8	435,6	179,9
	9	521,5	138,0	498,1	151,4	473,7	166,1	448,2	182,3
	10	535,7	140,3	511,8	153,8	486,9	168,5	460,8	184,7
142.2	4	512,2	142,3	493,6	161,3	474,5	181,6	452,6	203,7
	5	526,5	144,7	507,9	163,6	488,6	184,0	465,9	206,4
	6	540,9	147,1	522,4	165,8	502,6	186,4	479,2	209,3
	7	555,5	149,6	537,0	168,2	516,9	189,0	492,9	212,3
	8	570,4	152,0	551,8	170,6	531,4	191,7	506,6	215,5
	9	585,5	154,6	567,0	173,2	546,2	194,5	520,7	218,9
	10	601,1	157,3	582,5	175,9	561,3	197,6	535,2	222,6

**Note:** The power input is for compressor only; cooling cap. and power input referred to evap. fouling factor=0,0176m<sup>2</sup> °C/kW.

## Standard ratings ENERGYPLUS "B" XE 081.2 ÷ 142.2 ST, CN

Unit size	Evaporator leaving water temp. (°C)	AIR AMBIENT TEMPERATURE - °C											
		25		30		35		40		45		50	
		Cooling capac. (kW)	Power input (kW)	Cooling capac. (kW)	Power input (kW)	Cooling capac. (kW)	Power input (kW)	Cooling capac. (kW)	Power input (kW)	Cooling capac. (kW)	Power input (kW)	Cooling capac. (kW)	Power input (kW)
081.2	4	324,3	82,0	310,1	90,5	295,1	99,8	279,4	110,1	262,8	121,5	245,3	134,0
	5	334,2	83,2	319,6	91,8	304,3	101,1	288,3	111,4	271,4	122,7	253,5	135,2
	6	344,2	84,4	329,3	93,0	313,7	102,4	297,4	112,7	280,0	124,0	261,7	136,5
	7	354,5	85,7	339,2	94,3	323,2	103,7	306,5	114,1	288,9	125,4	270,2	137,9
	8	364,8	86,9	349,2	95,7	332,9	105,1	315,8	115,5	297,8	126,8	278,7	139,3
	9	375,3	88,3	359,3	97,0	342,7	106,5	325,3	116,9	306,8	128,3	287,4	140,7
	10	386,0	89,6	369,7	98,4	352,7	108,0	334,8	118,4	316,1	129,8	296,2	142,2
094.2	4	367,6	91,3	350,9	100,7	333,7	110,9	315,6	122,2	296,7	134,6	276,9	148,4
	5	378,9	92,7	361,9	102,1	344,3	112,4	325,8	123,7	306,5	136,1	286,2	149,8
	6	390,5	94,1	373,2	103,6	355,1	113,9	336,2	125,2	316,5	137,6	295,7	151,3
	7	402,3	95,6	384,5	105,1	366,0	115,4	346,7	126,8	326,6	139,2	305,3	152,8
	8	414,2	97,1	396,1	106,6	377,2	117,0	357,4	128,4	336,8	140,8	315,1	154,4
	9	426,3	98,6	407,7	108,2	388,4	118,7	368,3	130,0	347,2	142,5	325,1	156,1
	10	438,6	100,1	419,7	109,8	399,9	120,3	379,4	131,7	357,7	144,2	335,2	157,8
101.2	4	395,3	101,8	377,3	112,2	358,5	123,6	338,8	136,2	318,3	150,1	296,7	165,5
	5	407,3	103,4	388,8	113,9	369,6	125,3	349,5	137,9	328,7	151,8	306,6	167,1
	6	419,6	105,0	400,7	115,5	381,0	127,0	360,6	139,6	339,2	153,5	316,7	168,8
	7	432,0	106,7	412,7	117,2	392,6	128,8	371,6	141,4	349,8	155,3	326,9	170,6
	8	444,6	108,4	424,8	119,0	404,3	130,6	382,9	143,2	360,6	157,1	337,2	172,4
	9	457,3	110,1	437,1	120,8	416,2	132,4	394,3	145,1	371,5	159,0	347,6	174,2
	10	470,3	111,8	449,6	122,6	428,2	134,3	405,9	147,0	382,6	160,9	358,2	176,2
114.2	4	457,3	106,9	436,9	117,9	415,8	129,9	393,8	143,2	370,8	157,9	346,6	174,1
	5	471,6	108,5	450,8	119,5	429,1	131,6	406,6	144,9	383,0	159,5	358,5	175,7
	6	486,0	110,1	464,7	121,2	442,7	133,3	419,6	146,6	395,5	161,2	370,4	177,4
	7	500,7	111,8	479,0	122,9	456,4	135,1	432,9	148,4	408,3	163,0	382,6	179,1
	8	515,8	113,4	493,5	124,7	470,4	136,9	446,4	150,2	421,3	164,8	395,0	181,0
	9	530,9	115,2	508,2	126,5	484,6	138,7	460,0	152,1	434,4	166,7	407,6	182,8
	10	546,3	116,9	523,1	128,3	499,0	140,6	473,9	154,0	447,7	168,7	420,3	184,8
125.2	4	493,7	119,1	471,7	131,3	448,7	144,7	424,6	159,6	399,4	176,0	373,0	194,3
	5	508,8	120,9	486,3	133,2	462,7	146,6	438,2	161,5	412,4	177,9	385,6	196,1
	6	524,2	122,8	501,2	135,1	477,1	148,6	452,0	163,4	425,8	179,8	398,3	198,0
	7	539,8	124,7	516,2	137,0	491,6	150,5	466,0	165,4	439,2	181,8	411,1	199,9
	8	555,7	126,6	531,5	139,0	506,4	152,6	480,3	167,5	452,9	183,9	424,2	202,0
	9	571,6	128,6	547,1	141,1	521,4	154,7	494,7	169,6	466,7	186,0	427,0	203,0
	10	588,0	130,6	562,8	143,2	536,7	156,8	509,4	171,8	480,8	188,2	430,0	204,0
142.2	4	542,1	117,3	519,9	135,2	500,7	153,7	482,3	173,4	461,8	194,7	436,8	217,9
	5	556,6	119,7	534,8	137,1	515,8	155,4	497,1	175,0	476,2	196,5	450,6	220,1
	6	571,2	122,2	549,8	139,0	530,9	157,0	512,1	176,6	490,8	198,3	464,5	222,5
	7	586,0	124,7	564,9	141,0	546,2	158,7	527,2	178,3	505,6	200,2	478,6	224,9
	8	600,9	127,1	580,3	143,0	561,8	160,5	542,7	180,1	520,7	202,3	493,1	227,5
	9	616,2	129,6	596,1	145,0	577,7	162,3	558,5	182,0	536,1	204,5	507,9	230,3
	10	631,9	132,2	612,2	147,2	594,0	164,2	574,8	184,0	552,0	206,8	523,2	233,2

**Note:** The power input is for compressor only; cooling cap. and power input referred to evap. fouling factor=0,0176m<sup>2</sup> °C/kW.



## Standard ratings ENERGYPLUS “B” XE 081.2 ÷ 142.2 LN, XN

Unit size	Evaporator leaving water temp. (°C)	AIR AMBIENT TEMPERATURE - °C									
		25		30		35		40		45	
		Cooling capacity (kW)	Power input (kW)	Cooling capacity (kW)	Power input (kW)	Cooling capacity (kW)	Power input (kW)	Cooling capacity (kW)	Power input (kW)	Cooling capacity (kW)	Power input (kW)
081.2	4	317,7	85,9	303,2	94,7	288,0	104,4	272,1	115,1	255,2	126,9
	5	327,3	87,2	312,4	96,1	296,9	105,8	280,6	116,5	263,3	128,3
	6	336,9	88,6	321,8	97,5	306,0	107,2	289,3	118,0	271,6	129,7
	7	346,8	90,0	331,3	98,9	315,1	108,7	298,0	119,5	280,0	131,2
	8	356,8	91,4	340,9	100,4	324,3	110,2	306,9	121,0	288,5	132,8
	9	366,9	92,8	350,7	101,9	333,8	111,8	315,9	122,6	297,2	134,4
	10	377,2	94,3	360,6	103,5	343,4	113,4	325,2	124,2	306,0	136,0
094.2	4	358,4	96,5	341,6	106,2	324,0	116,9	305,7	128,7	286,3	141,7
	5	369,3	98,0	352,1	107,8	334,1	118,6	315,3	130,4	295,6	143,4
	6	380,3	99,6	362,7	109,5	344,4	120,2	325,2	132,1	305,0	145,1
	7	391,5	101,3	373,6	111,2	354,8	122,0	335,2	133,8	314,6	146,8
	8	403,0	102,9	384,5	112,9	365,4	123,8	345,3	135,6	324,2	148,6
	9	414,5	104,6	395,7	114,7	376,1	125,6	355,6	137,5	334,1	150,5
	10	426,3	106,4	407,0	116,5	386,9	127,5	366,0	139,4	344,1	152,4
101.2	4	384,5	108,0	366,1	118,9	347,0	130,8	327,1	144,1	306,1	158,7
	5	396,0	109,8	377,3	120,7	357,7	132,7	337,3	146,0	315,8	160,6
	6	407,6	111,6	388,5	122,6	368,6	134,6	347,7	147,9	325,8	162,5
	7	419,5	113,4	399,8	124,5	379,5	136,6	358,2	149,9	335,8	164,5
	8	431,4	115,4	411,4	126,5	390,5	138,6	368,8	151,9	346,0	166,6
	9	443,6	117,3	423,0	128,5	401,7	140,7	379,5	154,1	356,2	168,7
	10	455,9	119,3	434,9	130,6	413,1	142,8	390,4	156,2	366,6	170,8
114.2	4	447,8	112,0	427,2	123,3	405,8	135,8	383,6	149,6	360,2	164,9
	5	461,6	113,7	440,6	125,2	418,6	137,7	395,9	151,5	372,0	166,7
	6	475,5	115,5	454,0	127,0	431,7	139,6	408,3	153,4	384,0	168,6
	7	489,7	117,4	467,8	128,9	444,9	141,5	421,1	155,3	396,2	170,6
	8	504,2	119,2	481,6	130,9	458,3	143,5	434,0	157,4	408,5	172,6
	9	518,8	121,2	495,8	132,8	471,9	145,6	447,0	159,4	421,1	174,7
	10	533,6	123,1	510,1	134,9	485,7	147,7	460,2	161,6	433,8	176,8
125.2	4	482,6	125,2	460,2	137,9	436,9	151,9	412,4	167,4	386,9	184,6
	5	497,2	127,2	474,3	139,9	450,5	153,9	425,5	169,5	399,3	186,6
	6	512,0	129,2	488,6	142,0	464,2	156,1	438,7	171,6	412,0	188,8
	7	526,9	131,3	503,1	144,2	478,2	158,3	452,1	173,8	424,8	191,0
	8	542,1	133,5	517,7	146,4	492,2	160,6	465,7	176,1	437,9	193,2
	9	557,6	135,7	532,6	148,7	506,6	162,9	479,4	178,5	451,1	195,6
	10	573,1	137,9	547,7	151,0	521,1	165,3	493,4	180,9	464,4	198,0
142.2	4	531,4	125,4	510,9	143,5	492,3	162,6	473,2	182,9	451,1	205,0
	5	545,9	127,8	525,6	145,5	507,2	164,4	487,7	184,8	464,8	207,3
	6	560,5	130,2	540,5	147,5	522,0	166,2	502,3	186,8	478,9	209,6
	7	575,2	132,6	555,6	149,5	537,1	168,1	517,0	188,8	493,1	212,1
	8	590,1	135,0	570,9	151,5	552,4	170,0	532,1	190,9	507,6	214,6
	9	605,4	137,4	586,5	153,7	568,1	172,1	547,5	193,2	522,4	217,4
	10	621,1	139,9	602,5	155,9	584,1	174,3	563,3	195,7	537,6	220,4

**Note:** The power input is for compressor only; cooling cap. and power input referred to evap. fouling factor=0,0176m<sup>2</sup> °C/kW.

## Standard ratings ENERGYPLUS “B” HA 081.2 ÷ 142.2

Unit size	Evaporator leaving water temp. (°C)	AIR AMBIENT TEMPERATURE - °C											
		25		30		35		40		45		50	
		Cooling capac. (kW)	Power input (kW)	Cooling capac. (kW)	Power input (kW)	Cooling capac. (kW)	Power input (kW)	Cooling capac. (kW)	Power input (kW)	Cooling capac. (kW)	Power input (kW)	Cooling capac. (kW)	Power input (kW)
081.2	4	319,2	81,4	305,3	89,9	290,9	99,3	275,5	109,6	259,5	121,0	242,2	133,5
	5	328,9	82,6	314,6	91,1	299,8	100,5	284,2	110,8	267,8	122,2	250,2	134,7
	6	338,6	83,7	324,1	92,3	308,9	101,7	293,1	112,1	276,2	123,5	258,3	136,0
	7	348,5	84,9	333,7	93,6	318,3	103,0	302,0	113,4	284,8	124,8	266,5	137,3
	8	358,6	86,2	343,5	94,9	327,6	104,4	311,0	114,8	293,5	126,1	274,9	138,6
	9	368,8	87,4	353,3	96,2	337,2	105,7	320,3	116,1	302,4	127,5	283,4	140,0
	10	379,2	88,7	363,4	97,6	346,9	107,1	329,6	117,6	311,3	129,0	292,0	141,5
094.2	4	354,4	89,7	338,8	99,1	322,7	109,4	305,8	120,7	287,9	133,3	269,1	147,2
	5	365,1	91,0	349,2	100,4	332,6	110,8	315,4	122,1	297,3	134,7	278,0	148,5
	6	375,9	92,3	359,7	101,8	342,8	112,2	325,2	123,5	306,6	136,1	287,0	149,9
	7	386,9	93,7	370,3	103,2	353,1	113,6	335,2	125,0	316,2	137,5	296,2	151,4
	8	398,1	95,0	381,3	104,6	363,6	115,1	345,2	126,5	325,8	139,1	305,4	152,8
	9	409,5	96,4	392,2	106,1	374,2	116,6	355,4	128,1	335,7	140,6	314,9	154,4
	10	420,9	97,9	403,4	107,6	385,0	118,1	365,8	129,6	345,7	142,2	324,5	156,0
101.2	4	380,2	99,9	363,4	110,3	345,8	121,8	327,5	134,5	308,2	148,5	287,9	164,0
	5	391,4	101,3	374,3	111,8	356,4	123,3	337,7	136,0	317,9	150,1	297,3	165,6
	6	402,9	102,8	385,4	113,4	367,1	124,9	348,0	137,6	327,9	151,7	306,7	167,1
	7	414,5	104,3	396,6	115,0	378,0	126,6	358,5	139,3	337,9	153,3	316,4	168,8
	8	426,3	105,9	408,0	116,6	388,9	128,2	369,1	141,0	348,2	155,0	326,1	170,4
	9	438,3	107,5	419,6	118,2	400,2	129,9	379,8	142,7	358,5	156,8	336,0	172,2
	10	450,3	109,1	431,2	119,9	411,4	131,7	390,7	144,5	369,0	158,6	346,1	174,0
114.2	4	444,8	105,5	425,5	116,5	405,3	128,6	384,3	142,0	362,3	156,7	339,3	173,1
	5	458,3	107,0	438,6	118,1	418,0	130,2	396,6	143,5	374,1	158,3	350,6	174,6
	6	472,1	108,6	451,9	119,7	430,9	131,8	409,1	145,2	386,1	159,9	362,0	176,2
	7	486,2	110,1	465,6	121,3	444,2	133,5	421,8	146,9	398,4	161,6	373,8	177,9
	8	500,4	111,7	479,3	123,0	457,5	135,2	434,6	148,6	410,8	163,3	385,7	179,6
	9	514,8	113,3	493,4	124,7	471,0	137,0	447,6	150,4	423,3	165,1	397,7	181,3
	10	529,5	115,0	507,6	126,4	484,7	138,7	461,0	152,2	436,1	167,0	410,0	183,2
125.2	4	479,3	117,4	458,3	129,7	436,5	143,1	413,6	158,1	389,7	174,7	364,4	193,1
	5	493,7	119,1	472,3	131,4	450,0	144,9	426,6	159,9	402,2	176,4	376,4	194,8
	6	508,2	120,9	486,5	133,2	463,7	146,8	439,8	161,7	414,9	178,2	388,6	196,6
	7	523,1	122,6	500,7	135,0	477,5	148,6	453,3	163,6	427,8	180,1	401,0	198,4
	8	538,1	124,5	515,3	136,9	491,6	150,6	466,8	165,5	440,8	182,1	413,5	200,3
	9	553,4	126,3	530,1	138,8	505,9	152,5	480,6	167,5	454,1	184,1	420,3	202,3
	10	568,8	128,2	545,1	140,8	520,4	154,5	494,6	169,6	467,6	186,1	425,2	204,3
142.2	4	535,9	116,2	513,9	134,4	495,0	153,1	476,8	172,8	456,8	194,0	432,4	217,1
	5	550,2	118,7	528,6	136,3	509,8	154,7	491,4	174,4	470,9	195,8	445,8	219,3
	6	564,6	121,1	543,3	138,2	524,6	156,3	506,1	176,0	485,3	197,6	459,6	221,6
	7	579,1	123,5	558,1	140,1	539,6	158,0	521,0	177,6	499,8	199,5	473,4	224,0
	8	593,7	125,9	573,2	142,1	554,8	159,7	536,1	179,3	514,5	201,4	487,5	226,5
	9	608,6	128,4	588,5	144,1	570,4	161,4	551,6	181,1	529,6	203,5	502,0	229,2
	10	623,8	130,9	604,3	146,1	586,2	163,3	567,3	183,0	545,1	205,8	516,9	232,0

**Note:** The power input is for compressor only; cooling cap. and power input referred to evap. fouling factor=0,0176m<sup>2</sup> °C/kW.

# Total heat recovery ratings

## Energypius "B" SE 081.2 ÷ 142.2 ST/LN/XN

Unit size	Evaporator leaving water temperature °C	HEAT RECOVERY LEAVING WATER TEMPERATURE °C											
		40			45			50			55		
		Cooling capac. (kW)	Power input (kW)	Heat recov. (kW)	Cooling capac. (kW)	Power input (kW)	Heat recov. (kW)	Cooling capac. (kW)	Power input (kW)	Heat recov. (kW)	Cooling capac. (kW)	Power input (kW)	Heat recov. (kW)
081.2	4	286,2	95,8	382,0	271,4	105,9	377,3	255,8	117,0	372,8	239,2	129,3	368,5
	5	295,6	96,7	392,3	280,5	106,8	387,3	264,5	117,9	382,4	247,6	130,1	377,7
	6	305,2	97,7	402,9	289,8	107,7	397,5	273,5	118,8	392,3	256,2	131,0	387,2
	7	315,0	98,6	413,6	299,2	108,7	407,9	282,6	119,7	402,3	265,0	131,9	396,9
	8	325,0	99,6	424,6	308,9	109,6	418,5	291,9	120,7	412,6	274,0	132,8	406,8
	9	335,1	100,6	435,7	318,7	110,7	429,4	301,4	121,7	423,1	283,1	133,8	416,9
	10	345,5	101,6	447,1	328,7	111,7	440,4	311,0	122,7	433,7	292,4	134,8	427,2
094.2	4	318,5	104,9	423,4	302,1	116,0	418,1	284,8	128,1	412,9	266,6	141,6	408,2
	5	329,1	105,9	435,0	312,3	116,9	429,2	294,6	129,1	423,7	276,1	142,5	418,6
	6	339,8	106,9	446,7	322,6	117,9	440,5	304,6	130,0	434,6	285,7	143,4	429,1
	7	350,7	108,0	458,7	333,2	119,0	452,2	314,8	131,1	445,9	295,5	144,4	439,9
	8	361,8	109,0	470,8	343,9	120,0	463,9	325,2	132,1	457,3	305,5	145,4	450,9
	9	373,1	110,1	483,2	354,9	121,1	476,0	335,7	133,2	468,9	315,6	146,5	462,1
	10	384,6	111,2	495,8	366,0	122,3	488,3	346,5	134,3	480,8	326,0	147,6	473,6
101.2	4	346,7	113,6	460,3	329,0	125,6	454,6	310,5	138,9	449,4	291,1	153,6	444,7
	5	358,1	114,7	472,8	340,0	126,7	466,7	321,1	139,9	461,0	301,4	154,5	455,9
	6	369,7	115,7	485,4	351,2	127,7	478,9	332,0	140,9	472,9	311,8	155,5	467,3
	7	381,4	116,8	498,2	362,6	128,8	491,4	343,0	142,0	485,0	322,4	156,5	478,9
	8	393,4	117,9	511,3	374,2	129,9	504,1	354,2	143,1	497,3	333,2	157,6	490,8
	9	405,6	119,1	524,7	386,0	131,1	517,1	365,6	144,3	509,9	344,2	158,7	502,9
	10	418,0	120,2	538,2	398,0	132,3	530,3	377,2	145,4	522,6	355,3	159,9	515,2
114.2	4	386,6	124,4	511,0	367,0	137,6	504,6	346,4	152,3	498,7	324,9	168,5	493,4
	5	399,2	125,6	524,8	379,2	138,7	517,9	358,3	153,3	511,6	336,3	169,5	505,8
	6	412,1	126,7	538,8	391,7	139,9	531,6	370,3	154,4	524,7	347,9	170,5	518,4
	7	425,2	127,9	553,1	404,4	141,0	545,4	382,6	155,6	538,2	359,7	171,6	531,3
	8	438,6	129,1	567,7	417,3	142,3	559,6	395,0	156,7	551,7	371,7	172,7	544,4
	9	452,1	130,3	582,4	430,4	143,5	573,9	407,7	158,0	565,7	384,0	173,9	557,9
	10	465,9	131,6	597,5	443,8	144,8	588,6	420,6	159,2	579,8	396,4	175,1	571,5
125.2	4	421,6	134,8	556,4	400,5	149,2	549,7	378,3	165,3	543,6	355,1	183,1	538,2
	5	435,3	136,0	571,3	413,7	150,4	564,1	391,1	166,4	557,5	367,4	184,1	551,5
	6	449,2	137,2	586,4	427,2	151,6	578,8	404,2	167,5	571,7	380,0	185,1	565,1
	7	463,3	138,4	601,7	440,9	152,8	593,7	417,4	168,7	586,1	392,8	186,2	579,0
	8	477,7	139,7	617,4	454,8	154,0	608,8	430,9	169,9	600,8	405,8	187,4	593,2
	9	492,3	141,0	633,3	469,0	155,3	624,3	444,6	171,1	615,7	419,0	188,6	607,6
	10	507,1	142,3	649,4	483,4	156,7	640,1	458,6	172,5	631,1	432,5	189,9	622,4
142.2	4	443,5	136,7	580,2	420,4	151,0	571,4	396,2	166,8	563,0	371,0	184,4	555,4
	5	458,4	138,0	596,4	434,8	152,2	587,0	410,1	168,0	578,1	384,3	185,5	569,8
	6	473,6	139,3	612,9	449,5	153,5	603,0	424,3	169,3	593,6	398,0	186,7	584,7
	7	489,0	140,7	629,7	464,4	154,9	619,3	438,7	170,6	609,3	411,8	187,9	599,7
	8	504,8	142,1	646,9	479,7	156,3	636,0	453,4	172,0	625,4	426,0	189,2	615,2
	9	520,8	143,5	664,3	495,2	157,8	653,0	468,4	173,4	641,8	440,4	190,6	631,0
	10	537,2	145,0	682,2	511,0	159,2	670,2	483,6	174,9	658,5	455,1	192,1	647,2

# Total heat recovery ratings

## Energypus "B" SE 081.2 ÷ 142.2 XXN

Unit size	Evaporator leaving water temperature °C	HEAT RECOVERY LEAVING WATER TEMPERATURE °C											
		40			45			50			55		
		Cooling capac. (kW)	Power input (kW)	Heat recov. (kW)	Cooling capac. (kW)	Power input (kW)	Heat recov. (kW)	Cooling capac. (kW)	Power input (kW)	Heat recov. (kW)	Cooling capac. (kW)	Power input (kW)	Heat recov. (kW)
081.2	4	290,4	96,2	386,6	275,2	106,3	381,5	259,1	117,3	376,4	242,2	129,6	371,8
	5	300,0	97,2	397,2	284,5	107,2	391,7	268,1	118,2	386,3	250,8	130,4	381,2
	6	309,9	98,1	408,0	294,0	108,1	402,1	277,3	119,2	396,5	259,6	131,3	390,9
	7	320,0	99,1	419,1	303,7	109,1	412,8	286,6	120,1	406,7	268,6	132,3	400,9
	8	330,2	100,1	430,3	313,6	110,1	423,7	296,2	121,1	417,3	277,8	133,2	411,0
	9	340,6	101,1	441,7	323,7	111,2	434,9	305,9	122,2	428,1	287,1	134,2	421,3
	10	351,3	102,2	453,5	334,0	112,3	446,3	315,8	123,3	439,1	296,6	135,3	431,9
094.2	4	322,6	105,3	427,9	305,8	116,3	422,1	288,1	128,4	416,5	269,6	141,8	411,4
	5	333,4	106,3	439,7	316,2	117,3	433,5	298,2	129,4	427,6	279,2	142,8	422,0
	6	344,4	107,3	451,7	326,8	118,3	445,1	308,4	130,4	438,8	289,0	143,7	432,7
	7	355,5	108,4	463,9	337,6	119,4	457,0	318,8	131,5	450,3	299,0	144,7	443,7
	8	366,9	109,5	476,4	348,6	120,5	469,1	329,4	132,6	462,0	309,2	145,8	455,0
	9	378,5	110,6	489,1	359,8	121,6	481,4	340,2	133,7	473,9	319,6	146,9	466,5
	10	390,3	111,8	502,1	371,2	122,8	494,0	351,2	134,8	486,0	330,2	148,0	478,2
101.2	4	351,5	114,1	465,6	333,4	126,0	459,4	314,5	139,3	453,8	294,6	153,9	448,5
	5	363,2	115,1	478,3	344,7	127,1	471,8	325,4	140,3	465,7	305,1	154,9	460,0
	6	375,1	116,2	491,3	356,2	128,2	484,4	336,4	141,4	477,8	315,8	155,9	471,7
	7	387,2	117,4	504,6	367,8	129,3	497,1	347,7	142,5	490,2	326,6	156,9	483,5
	8	399,4	118,5	517,9	379,7	130,5	510,2	359,2	143,6	502,8	337,6	158,0	495,6
	9	412,0	119,7	531,7	391,8	131,7	523,5	370,8	144,8	515,6	348,9	159,2	508,1
	10	424,7	120,9	545,6	404,1	132,9	537,0	382,7	146,0	528,7	360,3	160,4	520,7
114.2	4	404,9	126,1	531,0	383,6	139,1	522,7	352,7	153,6	516,3	338,1	169,6	507,7
	5	418,6	127,3	545,9	396,8	140,3	537,1	367,1	154,8	531,9	350,3	170,7	521,0
	6	432,6	128,5	561,1	410,3	141,6	551,9	381,9	156,0	547,9	362,8	171,9	534,7
	7	446,9	129,8	576,7	424,1	142,9	567,0	397,0	157,2	564,2	375,6	173,1	548,7
	8	461,4	131,2	592,6	438,2	144,2	582,4	412,4	158,6	581,0	388,6	174,3	562,9
	9	476,2	132,5	608,7	452,4	145,6	598,0	428,0	159,9	597,9	401,8	175,7	577,5
	10	491,3	133,9	625,2	467,0	147,0	614,0	444,0	161,3	615,3	415,3	177,0	592,3
125.2	4	443,5	136,7	580,2	420,4	151,0	571,4	396,2	166,8	563,0	371,0	184,4	555,4
	5	458,4	138,0	596,4	434,8	152,2	587,0	410,1	168,0	578,1	384,3	185,5	569,8
	6	473,6	139,3	612,9	449,5	153,5	603,0	424,3	169,3	593,6	398,0	186,7	584,7
	7	489,0	140,7	629,7	464,4	154,9	619,3	438,7	170,6	609,3	411,8	187,9	599,7
	8	504,8	142,1	646,9	479,7	156,3	636,0	453,4	172,0	625,4	426,0	189,2	615,2
	9	520,8	143,5	664,3	495,2	157,8	653,0	468,4	173,4	641,8	440,4	190,6	631,0
	10	537,2	145,0	682,2	511,0	159,2	670,2	483,6	174,9	658,5	455,1	192,1	647,2
142.2	4	448,9	137,1	586,0	425,2	151,4	576,6	400,6	167,2	567,8	374,8	184,7	559,5
	5	464,1	138,5	602,6	440,0	152,7	592,7	414,8	168,4	583,2	388,4	185,8	574,2
	6	479,6	139,8	619,4	455,0	154,0	609,0	429,2	169,7	598,9	402,3	187,1	589,4
	7	495,5	141,2	636,7	470,3	155,4	625,7	444,0	171,1	615,1	416,5	188,4	604,9
	8	511,6	142,7	654,3	485,8	156,9	642,7	459,0	172,5	631,5	430,9	189,7	620,6
	9	528,0	144,2	672,2	501,7	158,4	660,1	474,3	174,0	648,3	445,7	191,1	636,8
	10	544,8	145,7	690,5	517,9	159,9	677,8	489,9	175,5	665,4	460,7	192,6	653,3

# Total heat recovery ratings

## Energypus "B" XE 081.2 ÷ 142.2 ST/LN/XN

Unit size	Evaporator leaving water temperature °C	HEAT RECOVERY LEAVING WATER TEMPERATURE °C											
		40			45			50			55		
		Cooling capac. (kW)	Power input (kW)	Heat recov. (kW)	Cooling capac. (kW)	Power input (kW)	Heat recov. (kW)	Cooling capac. (kW)	Power input (kW)	Heat recov. (kW)	Cooling capac. (kW)	Power input (kW)	Heat recov. (kW)
081.2	4	290,4	96,2	386,6	275,2	106,3	381,5	259,1	117,3	376,4	242,2	129,6	371,8
	5	300,0	97,2	397,2	284,5	107,2	391,7	268,1	118,2	386,3	250,8	130,4	381,2
	6	309,9	98,1	408,0	294,0	108,1	402,1	277,3	119,2	396,5	259,6	131,3	390,9
	7	320,0	99,1	419,1	303,7	109,1	412,8	286,6	120,1	406,7	268,6	132,3	400,9
	8	330,2	100,1	430,3	313,6	110,1	423,7	296,2	121,1	417,3	277,8	133,2	411,0
	9	340,6	101,1	441,7	323,7	111,2	434,9	305,9	122,2	428,1	287,1	134,2	421,3
	10	351,3	102,2	453,5	334,0	112,3	446,3	315,8	123,3	439,1	296,6	135,3	431,9
094.2	4	326,1	105,6	431,7	308,9	116,6	425,5	290,9	128,7	419,6	272,0	142,1	414,1
	5	337,1	106,7	443,8	319,5	117,6	437,1	301,1	129,7	430,8	281,8	143,0	424,8
	6	348,2	107,7	455,9	330,3	118,7	449,0	311,5	130,7	442,2	291,8	144,0	435,8
	7	359,7	108,8	468,5	341,3	119,8	461,1	322,1	131,8	453,9	302,0	145,0	447,0
	8	371,3	109,9	481,2	352,5	120,9	473,4	332,9	132,9	465,8	312,4	146,1	458,5
	9	383,1	111,1	494,2	364,0	122,1	486,1	344,0	134,1	478,1	323,0	147,3	470,3
	10	395,2	112,2	507,4	375,6	123,2	498,8	355,2	135,3	490,5	333,7	148,4	482,1
101.2	4	355,7	114,5	470,2	337,2	126,4	463,6	317,8	139,6	457,4	297,6	154,2	451,8
	5	367,6	115,5	483,1	348,7	127,5	476,2	328,9	140,6	469,5	308,3	155,2	463,5
	6	379,7	116,7	496,4	360,4	128,6	489,0	340,2	141,7	481,9	319,1	156,2	475,3
	7	392,0	117,8	509,8	372,3	129,8	502,1	351,7	142,9	494,6	330,2	157,3	487,5
	8	404,6	119,0	523,6	384,4	130,9	515,3	363,4	144,0	507,4	341,4	158,4	499,8
	9	417,4	120,2	537,6	396,8	132,2	529,0	375,3	145,2	520,5	352,9	159,6	512,5
	10	430,4	121,4	551,8	409,4	133,4	542,8	387,4	146,5	533,9	364,5	160,8	525,3
114.2	4	404,9	126,1	531,0	383,6	139,1	522,7	361,3	153,6	514,9	338,1	169,6	507,7
	5	418,6	127,3	545,9	396,8	140,3	537,1	374,1	154,8	528,9	350,3	170,7	521,0
	6	432,6	128,5	561,1	410,3	141,6	551,9	387,1	156,0	543,1	362,8	171,9	534,7
	7	446,9	129,8	576,7	424,1	142,9	567,0	400,4	157,2	557,6	375,6	173,1	548,7
	8	461,4	131,2	592,6	438,2	144,2	582,4	413,9	158,6	572,5	388,6	174,3	562,9
	9	476,2	132,5	608,7	452,4	145,6	598,0	427,7	159,9	587,6	401,8	175,7	577,5
	10	491,3	133,9	625,2	467,0	147,0	614,0	441,7	161,3	603,0	415,3	177,0	592,3
125.2	4	443,5	136,7	580,2	420,4	151,0	571,4	396,2	166,8	563,0	371,0	184,4	555,4
	5	458,4	138,0	596,4	434,8	152,2	587,0	410,1	168,0	578,1	384,3	185,5	569,8
	6	473,6	139,3	612,9	449,5	153,5	603,0	424,3	169,3	593,6	398,0	186,7	584,7
	7	489,0	140,7	629,7	464,4	154,9	619,3	438,7	170,6	609,3	411,8	187,9	599,7
	8	504,8	142,1	646,9	479,7	156,3	636,0	453,4	172,0	625,4	426,0	189,2	615,2
	9	520,8	143,5	664,3	495,2	157,8	653,0	468,4	173,4	641,8	440,4	190,6	631,0
	10	537,2	145,0	682,2	511,0	159,2	670,2	483,6	174,9	658,5	455,1	192,1	647,2
142.2	4	448,9	137,1	586,0	425,2	151,4	576,6	400,6	167,2	567,8	374,8	184,7	559,5
	5	464,1	138,5	602,6	440,0	152,7	592,7	414,8	168,4	583,2	388,4	185,8	574,2
	6	479,6	139,8	619,4	455,0	154,0	609,0	429,2	169,7	598,9	402,3	187,1	589,4
	7	495,5	141,2	636,7	470,3	155,4	625,7	444,0	171,1	615,1	416,5	188,4	604,9
	8	511,6	142,7	654,3	485,8	156,9	642,7	459,0	172,5	631,5	430,9	189,7	620,6
	9	528,0	144,2	672,2	501,7	158,4	660,1	474,3	174,0	648,3	445,7	191,1	636,8
	10	544,8	145,7	690,5	517,9	159,9	677,8	489,9	175,5	665,4	460,7	192,6	653,3

# Total heat recovery ratings

## Energypus "B" HA 081.2 ÷ 142.2

Unit size	Evaporator leaving water temperature °C	HEAT RECOVERY LEAVING WATER TEMPERATURE °C											
		40			45			50			55		
		Cooling capac. (kW)	Power input (kW)	Heat recov. (kW)	Cooling capac. (kW)	Power input (kW)	Heat recov. (kW)	Cooling capac. (kW)	Power input (kW)	Heat recov. (kW)	Cooling capac. (kW)	Power input (kW)	Heat recov. (kW)
081.2	4	286,2	95,8	382,0	271,4	105,9	377,3	255,8	117,0	372,8	239,2	129,3	368,5
	5	295,6	96,7	392,3	280,5	106,8	387,3	264,5	117,9	382,4	247,6	130,1	377,7
	6	305,2	97,7	402,9	289,8	107,7	397,5	273,5	118,8	392,3	256,2	131,0	387,2
	7	315,0	98,6	413,6	299,2	108,7	407,9	282,6	119,7	402,3	265,0	131,9	396,9
	8	325,0	99,6	424,6	308,9	109,6	418,5	291,9	120,7	412,6	274,0	132,8	406,8
	9	335,1	100,6	435,7	318,7	110,7	429,4	301,4	121,7	423,1	283,1	133,8	416,9
	10	345,5	101,6	447,1	328,7	111,7	440,4	311,0	122,7	433,7	292,4	134,8	427,2
094.2	4	293,0	94,6	387,6	277,8	104,5	382,3	261,9	115,4	377,3	245,1	127,5	372,6
	5	302,8	95,5	398,3	287,3	105,3	392,6	271,0	116,2	387,2	253,9	128,3	382,2
	6	312,8	96,4	409,2	297,0	106,2	403,2	280,4	117,1	397,5	262,8	129,1	391,9
	7	323,0	97,3	420,3	306,8	107,2	414,0	289,9	118,0	407,9	272,0	130,0	402,0
	8	333,4	98,2	431,6	316,9	108,1	425,0	299,6	119,0	418,6	281,3	130,9	412,2
	9	344,0	99,2	443,2	327,1	109,1	436,2	309,4	120,0	429,4	290,8	131,9	422,7
	10	354,7	100,2	454,9	337,6	110,1	447,7	319,5	121,0	440,5	300,5	132,9	433,4
101.2	4	346,7	113,6	460,3	329,0	125,6	454,6	310,5	138,9	449,4	291,1	153,6	444,7
	5	358,1	114,7	472,8	340,0	126,7	466,7	321,1	139,9	461,0	301,4	154,5	455,9
	6	369,7	115,7	485,4	351,2	127,7	478,9	332,0	140,9	472,9	311,8	155,5	467,3
	7	381,4	116,8	498,2	362,6	128,8	491,4	343,0	142,0	485,0	322,4	156,5	478,9
	8	393,4	117,9	511,3	374,2	129,9	504,1	354,2	143,1	497,3	333,2	157,6	490,8
	9	405,6	119,1	524,7	386,0	131,1	517,1	365,6	144,3	509,9	344,2	158,7	502,9
	10	418,0	120,2	538,2	398,0	132,3	530,3	377,2	145,4	522,6	355,3	159,9	515,2
114.2	4	391,7	124,9	516,6	371,6	138,1	509,7	350,6	152,6	503,2	328,6	168,8	497,4
	5	404,6	126,0	530,6	384,1	139,2	523,3	362,7	153,7	516,4	340,2	169,8	510,0
	6	417,8	127,2	545,0	396,8	140,3	537,1	375,0	154,8	529,8	352,0	170,9	522,9
	7	431,2	128,4	559,6	409,8	141,6	551,4	387,5	156,0	543,5	364,1	172,0	536,1
	8	444,8	129,6	574,4	423,0	142,8	565,8	400,3	157,2	557,5	376,4	173,2	549,6
	9	458,7	130,9	589,6	436,5	144,1	580,6	413,2	158,5	571,7	388,9	174,4	563,3
	10	472,8	132,2	605,0	450,1	145,4	595,5	426,4	159,8	586,2	401,6	175,6	577,2
125.2	4	427,6	135,3	562,9	406,0	149,7	555,7	383,3	165,7	549,0	359,5	183,4	542,9
	5	441,6	136,5	578,1	419,5	150,9	570,4	396,4	166,8	563,2	372,1	184,5	556,6
	6	455,9	137,7	593,6	433,3	152,1	585,4	409,7	168,0	577,7	385,0	185,5	570,5
	7	470,3	139,0	609,3	447,4	153,4	600,8	423,3	169,2	592,5	398,1	186,7	584,8
	8	485,1	140,3	625,4	461,6	154,6	616,2	437,1	170,4	607,5	411,4	187,9	599,3
	9	500,1	141,6	641,7	476,2	156,0	632,2	451,2	171,8	623,0	424,9	189,1	614,0
	10	515,3	143,0	658,3	490,9	157,4	648,3	465,4	173,1	638,5	438,7	190,5	629,2
142.2	4	443,5	136,7	580,2	420,4	151,0	571,4	396,2	166,8	563,0	371,0	184,4	555,4
	5	458,4	138,0	596,4	434,8	152,2	587,0	410,1	168,0	578,1	384,3	185,5	569,8
	6	473,6	139,3	612,9	449,5	153,5	603,0	424,3	169,3	593,6	398,0	186,7	584,7
	7	489,0	140,7	629,7	464,4	154,9	619,3	438,7	170,6	609,3	411,8	187,9	599,7
	8	504,8	142,1	646,9	479,7	156,3	636,0	453,4	172,0	625,4	426,0	189,2	615,2
	9	520,8	143,5	664,3	495,2	157,8	653,0	468,4	173,4	641,8	440,4	190,6	631,0
	10	537,2	145,0	682,2	511,0	159,2	670,2	483,6	174,9	658,5	455,1	192,1	647,2

# Partial heat recovery ratings

## Energypus “B” 081.2 ÷ 142.2

Unit size		HEAT RECOVERY LEAVING WATER TEMPERATURE °C		
		45	50	55
		Heating capacity (kW)	Heating capacity (kW)	Heating capacity (kW)
081.2	Evaporator leaving water temp. 7 °C ΔT 5 °C – ambient temperature 35 °C	38	29	20
094.2		42	32	22
101.2		46	35	24
114.2		52	40	27
125.2		58	44	30
142.2		58	44	30

### Water pump diagram

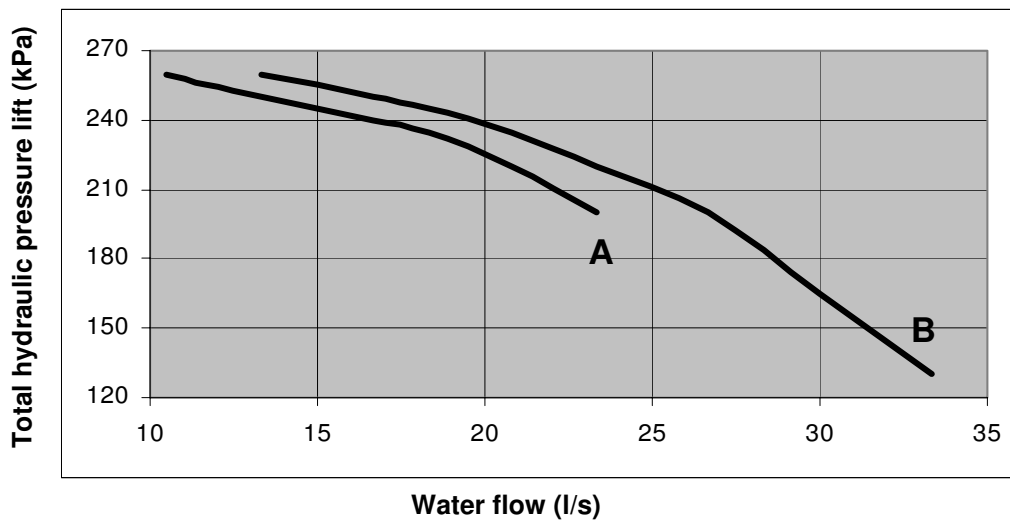

Type pump	Unit models	Motor power	AMPS	Electric protection	Voltage
		kW	A		V / Hz
<b>A</b>	081.2 - 101.2 SE 081.2 - 125.2 XE	7,5	16,0	IP54	400/3/50
<b>B</b>	114.2 - 142.2 SE 142.2 XE	7,5	16,0	IP54	400/3/50

**Note:** to have the useful hydraulic lift is necessary to subtract the evaporator pressure drop to the total hydraulic lift.

# Evaporator pressure drop – ENERGYPLUS “B” SE ST, CN, LN, XN, XXN; ENERGYPLUS “B” XE ST, CN, LN, XN; ENERGYPLUS “B” HA

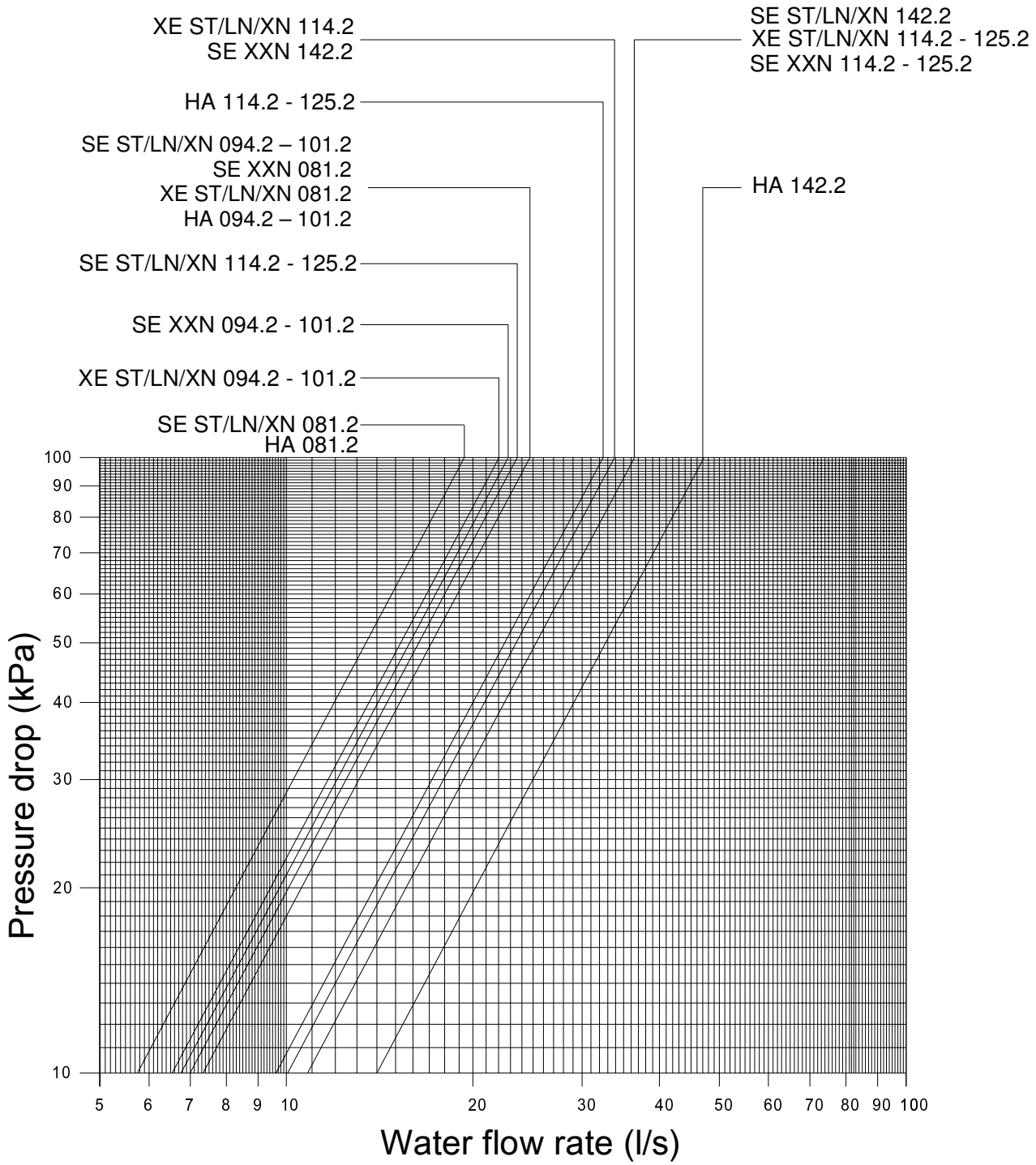



**Total heat recovery pressure drop – Energyplus “B” SE ST, CN, LN, XN, XXN; Energyplus “B” XE ST, CN, LN, XN; Energyplus “B” HA**

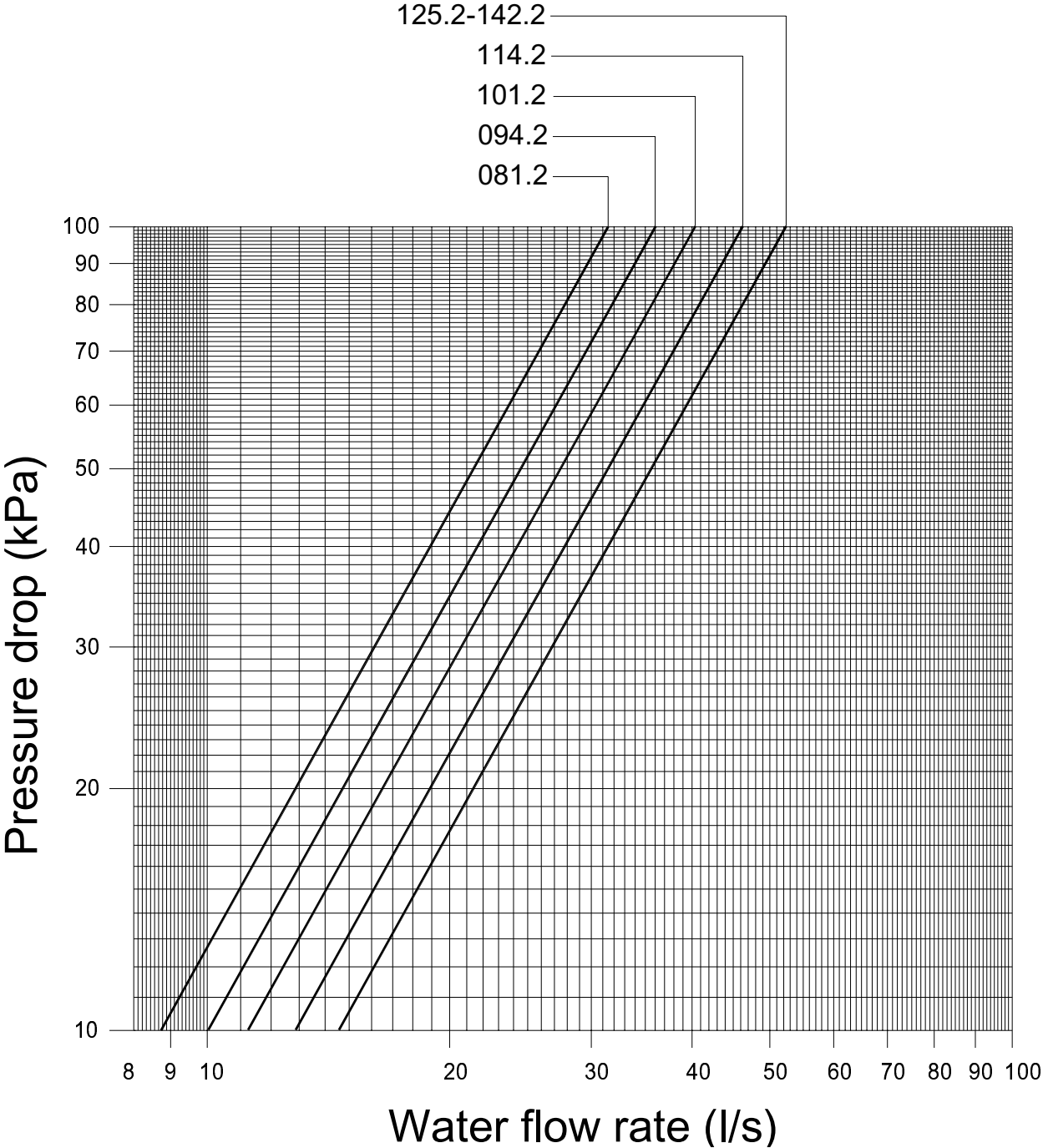

**Partial heat recovery pressure drop – Energyplus “B” SE ST, CN, LN, XN, XXN; Energyplus “B” XE ST, CN, LN, XN; Energyplus “B” HA**

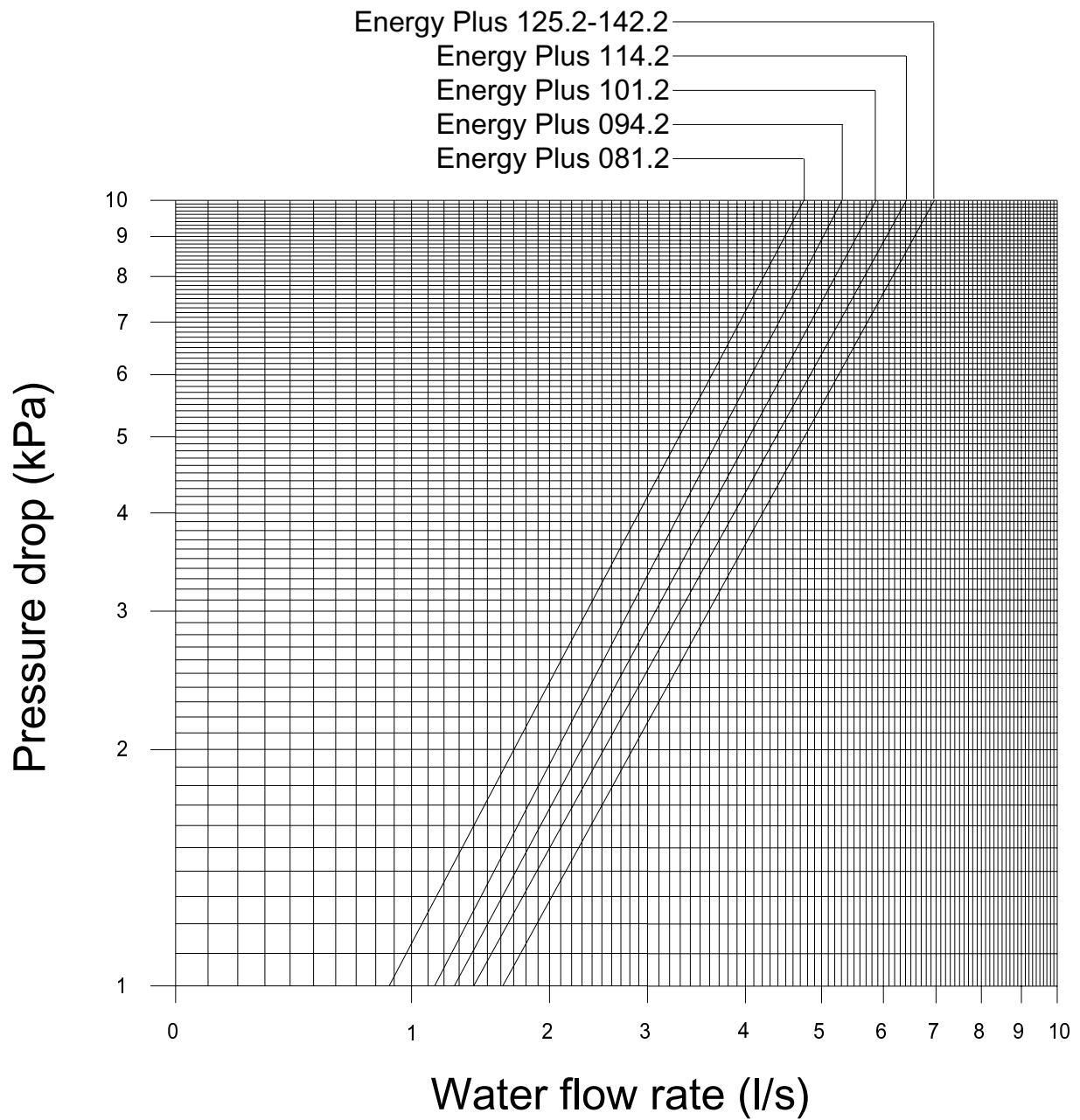

# Dimensions Energyplus "B" SE, XE, HA 081.2 ÷ 142.2 ST – CN – LN – XN – XXN

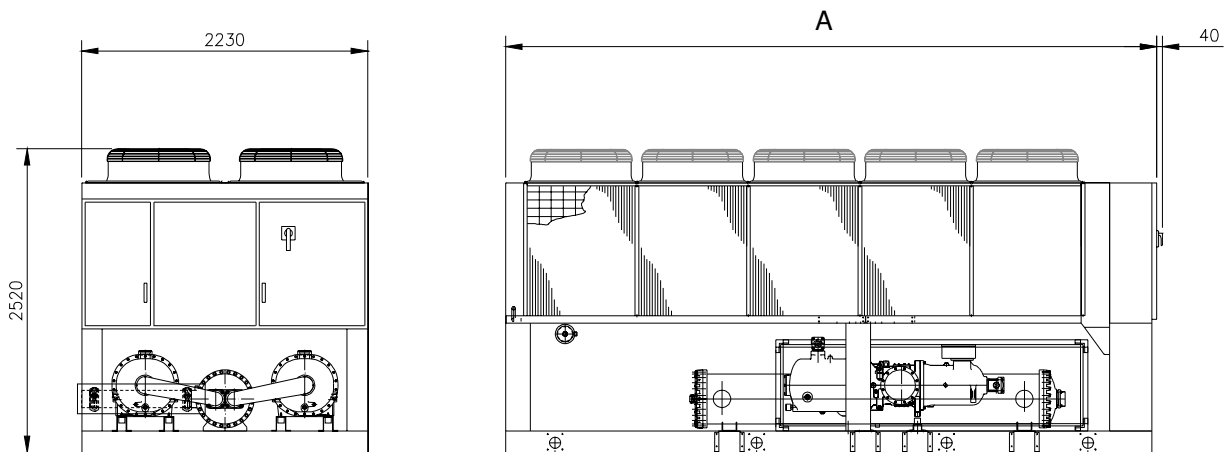

ENERGYPLUS "B" SE Units	Length – A (mm)	Width – B (mm)	Height (mm)
<b>ST-CN-LN-XN</b>			
ENERGYPLUS "B" SE 081.2	2790	2230	2520
ENERGYPLUS "B" SE 094.2 – 101.2 – 114.2 – 125.2	3460	2230	2520
ENERGYPLUS "B" SE 142.2	4355	2230	2520
<b>XXN</b>			
ENERGYPLUS "B" SE 081.2	3460	2230	2520
ENERGYPLUS "B" SE 094.2 – 101.2	4355	2230	2520
ENERGYPLUS "B" SE 114.2 – 125.2 – 142.2	5255	2230	2520

ENERGYPLUS "B" XE Units	Length – A (mm)	Width – B (mm)	Height (mm)
<b>ST-CN-LN-XN</b>			
ENERGYPLUS "B" XE 081.2 – 101.2	3460	2230	2520
ENERGYPLUS "B" XE 114.2 – 125.2	4355	2230	2520
ENERGYPLUS "B" XE 142.2	5255	2230	2520

ENERGYPLUS "B" HA Units	Length – A (mm)	Width – B (mm)	Height (mm)
<b>ST-CN</b>			
ENERGYPLUS "B" SE 081.2 – 094.2 – 101.2	3460	2230	2520
ENERGYPLUS "B" SE 114.2 – 125.2	4355	2230	2520
ENERGYPLUS "B" SE 142.2	5255	2230	2520

# Technical Specification for Energyplus “B” – Air Cooled Screw Chiller

To supply and install, where specified in the project n° ..... unit(s) air cooled water chiller with cooling capacity of ..... kW, to cool ..... l/sec. of water from ..... °C to ..... °C working with ..... °C ambient temperature.

The unit should work with electricity at ..... V, 3ph, 50Hz. The electrical power absorbed should not exceed ..... kW. The units COP will be at least ..... at the working conditions of the project. Part load COP will be at least ..... at the working conditions of the project.

The units will have 2 independent refrigerant circuits, and the respective electronic microprocessor will allow the starting of the compressors. Each chiller will be factory assembled on a robust baseframe made of zinc coated steel, protected by an epoxy paint.

The unit will be tested at full load in the factory at the nominal working conditions and water temperatures. Before shipment a full test will be held to avoid any losses. Chiller will be delivered to the job site completely assembled and charged with refrigerant and oil.

Comply with the manufacturer instructions for rigging and handling equipment.

## GENERAL

All units should be designed and manufactured in accordance with applicable selections of the following which are equivalent to American Air-conditioning industry applicable codes:

Rating of chillers	EN 12055
Construction of pressure vessel	TUV Standards (on request)
Electrical codes	IEC 204-1 CEI 44-5 Elect. & Safety Codes
Safety Codes	CEI-EN 60204–1 Codes
Manufacturing Quality Stds	ISO 9001:2000

## REFRIGERANT

Only HFC 134a will be accepted

## UNIT DESCRIPTION

Each chiller consist of multiple semi-hermetic rotary screw compressor, direct expansion avaporator, air-cooled condenser section, control system and all components necessary for safe and controlled unit operation.

## NOISE LEVEL AND VIBRATIONS

Sound pressure level at 1 meter distance in free field, semispheric conditions, shall not exceed .....dBA. The sound pressure levels must be rated in accordance to ISO 3744. Other types of rating unacceptable. Vibration level should not exceed 2 mm/s.

## DIMENSIONS

Unit length shall not exceed ..... mm, unit width shall not exceed ..... mm, unit height shall not exceed ..... mm.

## CHILLER COMPONENTS

### Compressors

- ✓ The compressors shall be field serviceable, semi-hermetic, single-screw type with one main helical rotor meshing with two opposed gaterotor. If a twin-screw compressor is used, the manufacturer shall provide an external 5-year part and labor warranty covering all moving parts due to the large bearing load inherent with this design.  
The two exactly opposed gaterotors create two exactly opposed compression cycles which results in balanced forces acting on the compressor. The gaterotors will be constructed of a carbon impregnated engineered composite material. The gaterotor supports will be constructed of cast iron.
- ✓ The oil injection shall be used for these compressors in order to get high COP also at high condensing pressure and low sound pressure levels in each load condition.

- ✓ Refrigerant system differential pressure shall provide oil flow through service replaceable, 0.5 micron, full flow, cartridge type oil filter internal to compressor. Filter bypass or oil pump not acceptable.
- ✓ The compressor's oil cooling must be realized by liquid injection. External dedicated heat exchanger and additional piping to carry the oil from the compressor to heat exchanger and viceversa will be not accepted.
- ✓ The compressor shall be provided with an integrated, high efficiency, oil separator and with built-in oil filter.
- ✓ The compressor shall be direct electrical drive, without gear transmission between the screw and the electrical motor. The motor's compressor shall be designed for star/delta. Soft start should be available as option.
- ✓ The compressor casing shall be provided with ports to realize economized refrigerant cycles.
- ✓ Shall be present two thermal protection realized by a thermistor for high temperature protection to motor and a thermistor for discharge gas high temperature protection.
- ✓ The compressor shall be provided with an automatic spring return of capacity control valve to the minimum load position to ensure compressor starting always at minimum motor load.

### **Evaporator**

- ✓ The units shall be supplied with shell and tubes counter-flow evaporator single refrigerant pass. It will be direct expansion with refrigerant inside the tubes and water outside (shell side) with carbon steel tube sheets, with straight copper tubes that are spirally wound internally for higher efficiencies, expanded on the tube plates.
- ✓ The external shell, shall be linked with an electrical heater to prevent freezing to -28 C ambient temperature, commanded by a thermostat and shall be insulated with flexible, closed cell polyurethane insulation material.
- ✓ The evaporator will have 2 circuits, one for each compressor and shall be single refrigerant pass.
- ✓ If a plate to plate heat exchanger is used, the manufacturer shall provide to furniture an adequate buffer tank to avoid frequently compressors star-stop and to allow a good evaporator leaving water temperature control. The manufacturer also shall provide to furniture a feed water line filter, a monitoring system of the refrigerant pressure drop inside the plate to plate heat exchanger and a system to protect the component from hydraulic pressure waves caused by water circulation pump stop.
- ✓ Evaporator is manufactured in accordance to PED approval.

### **Condenser coil**

- ✓ The condenser coils are constructed with internally enhanced seamless copper tubes having a "W" configuration and arranged in a staggered row pattern and mechanically expanded into lanced and rippled aluminium fins with full fin collars for higher efficiencies. The space between the fins are given by a collar that will increase the surface area in connection with the tubes, protecting them from ambient corrosion.
- ✓ The coils will have an integral subcooler circuit which provides sufficient subcooling to effectively eliminate the possibility of liquid flashing and increase the unit's efficiency of 5-7% without an increase in power absorbed, and the surface area will be designed in order to have an air velocity not higher than 2.8 m/sec.

### **Condenser fans**

- ✓ The fans used in conjunction with the condenser coils, shall be helical type with aerofoil blades for higher efficiencies and lower noise. Each fan shall be equipped with a heavy-gauge fan guard.
- ✓ The air discharge shall be vertical and each fan must be coupled to the electrical motor, supplied as standard to IP54 and capable to work to ambient temperatures of -40 C to +55 C. There is also an accident protection within the motors.

### **Refrigerant circuit**

- ✓ The unit must have refrigerant circuits completely independent of each other with one compressor per circuit.

- ✓ Each circuit shall include an: electronic expansion valve, compressor discharge shut-off valve, a liquid line shut-off valve with charging connection, replaceable core filter-drier, sight glass with moisture indicator and insulated suction line. Suction line shut-off valve should be available as option.

### **Regulation of cooling capacity**

- ✓ Each unit will have a microprocessor for the control of compressor slide valve's position (2 slide valves, one for each compressor's cycles).
- ✓ The slides shall have a stepless motion that allows a unit's operation with infinitely variable capacity control down to 12,5% (2 compressors) of the cooling capacity. The chiller shall be capable of stable operation to a minimum of 12,5% of full load without hot gas bypass.
- ✓ Step unloading unacceptable because of evaporator leaving water temperature fluctuation and low compressor's efficiency at partial load.
- ✓ The system shall stage the unit based on the leaving water temperature.

### **Condensation control**

- ✓ The units will be provided with an automatic control for condensing pressure which ensures the working at low external temperatures down to +10 C, because of the ON/OFF of the condenser fans, to maintain condensing pressure. Fan speed control, to allow unit's operation with very low ambient temperature, should be available as option.

### **Control panel**

- ✓ Field power connections, control interlock terminals, and unit control system should be centrally located in an electric panel (IP 54).
- ✓ The Power components and control equipment shall be separately mounted in different compartments of the control panel.
- ✓ The Compressor starting method will be star/delta, with an option for Softstart.
- ✓ Power and starting controls should include fuses and contactors for the compressor and fan motor windings.
- ✓ Operating and safety controls should include energy saving; emergency stop switch; thermal overload protection for each compressor motor; high and low pressure cut-out switch (for each refrigerant circuit); anti-freeze thermostat; cut-out switch for each compressor.
- ✓ All of the information regarding the unit shall be shown on a display with a built-in calendar and clock that will provide unit scheduling throughout the year.
- ✓ The following features and functions shall be included:
  - resetting chilled water temperature by controlling the return water temperature or by a remote 4-20 mA DC signal;
  - soft load function to prevent the system from operating at full load during the chilled fluid pulldown period;
  - password protection of critical parameters of control;
  - discharge pressure control through intelligent cycling or speed variation of the condenser fans.
  - start-to-start and stop-to-start timers to provide minimum compressor off-time with maximum motor protection;
  - communication capability with a PC or remote monitoring;
  - lead-lag selection by manual or automatically by circuit run hours;
  - double set point for brine unit version;
  - scheduling via internal time clock to allow programming of a yearly start-stop schedule accommodating weekends and holidays.

## **Display Capabilities**

The controller as a minimum shall be capable of monitoring and displaying the following data: -

### Operating Conditions

Entering Evaporator fluid Temp.  
Leaving Evaporator fluid Temp.  
Operating Chilled Fluid Setpoint  
Oil / Discharge gas Press. (per comp.)  
Condensing Press. (per comp.)  
Evaporator Press. (per comp.)  
Unit Enabled  
Compressor Enabled  
Water Setpoint Reset  
Demand Limit or Current Limit  
(Site Selectable)

### Alarms

Phase Monitor  
Freeze Protection  
Evaporator Flow  
Low Gas Pressure (per comp.)  
Transition Fault, (per comp.)  
Oil Diff. press. (per comp.)  
Low Oil Pressure (per comp.)  
High Gas Pressure Trip (per comp.)  
Motor Overload, (per comp.)  
Transducer faults  
Units Off-Line  
External fault  
Processor Faults  
Maintenance requirements

## **Standard Customer Interfaces**

The controller as a minimum shall be capable of providing the following interlocks: -

Chiller Enable Signal: Digital Input,  
contact must be capable of handling 110 Volts, 50HZ, 1 Amp.

Chiller Common Fault: Volt free, normally open, digital contact,  
Must be capable of switching 250 V, 50 HZ, 10 Amp.

Pump Enable Signal:: Volt free, normally open, digital contact,  
Must be capable of switching 250 V, 50 HZ, 10 Amp.

Setpoint Override:: 4 – 20 mA DC analogue input signal.

Demand Limit:: 4 – 20 mA DC analogue input signal.

Or

Current Limit:: 4 – 20 mA DC analogue input signal.

## **Optional Customer Interfaces**

Compressor Running Signals: Volt free, normally open, digital contact,  
Capable of switching 250 V, 50 HZ, 10 Amp.

## **Optional High Level Communications Interface**

Using ModBus, Lonworks or Bacnet protocols

We reserve the right to make changes in design and construction at any time without notice, thus the cover picture is not binding.



**McQuay**<sup>®</sup>  
International

**McQuay Italia S.P.A.**

S.S. Nettunense, km 12+300 – 00040 Cecchina (Roma) Italia – Tel. (06) 937311 – Fax (06) 9374014 – Email: [info@mcquayeuropa.com](mailto:info@mcquayeuropa.com)

[www.mcquayeuropa.com](http://www.mcquayeuropa.com)