

Air cooled screw chillers

ALS 081.2 ÷ 142.2



Introduction

Purpose of the manual

The manual allows the installer and the operator to perform correctly all the operations required for the installation and maintenance of the chiller without provoking any damages to the unit or to the qualified personnel. Therefore the manual is essential to help qualified personnel that have to arrange the equipment to provide the correct installation in accordance with local codes and regulation.

Inspection

When the equipment is received, all items on the bill of lading should be carefully checked to insure a complete shipment. All units should be carefully checked and all shipping damage should be reported to the carrier. The unit serial plate should be checked before unloading the unit to be sure that it agrees with the power supply available. Physical damage to unit after acceptance is not McQuay's responsibility.

Responsibilities

McQuay Italia declines all present and future responsibilities referred to injuries to people and damage to things and unit, coming from operators negligence, the unrespected installation/maintenance data carrier in this manual, the lacking of the current regulations respect referred to the safety of the equipment and the qualified personnel.

Servicing and maintenance

Servicing and maintenance of these units must be carried out by experienced personnel with specific training in refrigeration. Regular checking of safety devices should be carried out but routine maintenance should be carried out in line with the recommendations list in the main section.

The simple design of the refrigeration circuit minimizes potential problems during normal unit operation.

Characteristics

General description

McQuay air-cooled water chillers are complete, self-contained automatic refrigerating units that include the latest in engineering components arranged to provide a compact and efficient unit. Each unit is completely assembled, factory wired, evacuated, charged, tested and comes complete and ready for installation. Each unit consists of multiple air-cooled condensers with integral subcooler sections, multiple accessible semi-hermetic single-screw compressors, multiple circuit shell-and-tube evaporator, and complete refrigerant piping. Liquid line components included are manual liquid line shutoff valves, charging valves, filter-driers, sightglass/moisture indicators, and electronic expansion valves. Other features include compressor heaters, an evaporator heater for low ambient water freeze protection, automatic one time pumpdown of refrigerant circuit upon circuit shutdown, and an advanced fully integrated microprocessor control system.

Safety measures

The unit must be suitably clamped to the ground.

It is necessary to follow these cautions and warnings:

- The unit must be lifted only by using the proper tools able to support the weight of the unit.
- No admittance to unauthorized or unqualified personnel should be allowed.
- No operation on electrical components is allowed without having switched off electricity supply.
- No operation on electrical components is allowed without using insulated platforms; no water or moisture should be present.
- All the operation on refrigerant circuit and pressurised components are to be performed by qualified personnel only.
- Compressor substitution or oil addition must be performed by qualified personnel only.
- Sharp edges and coil surface are a potential injury hazard. Avoid contact with them.
- Disconnect all power to the unit while servicing condenser fan motors. Failure to do so may cause body injury.
- Avoid contamination of unrelated bodies into the water piping during the unit connection to the water system.
- It is necessary that a mechanical filter is fitted to the piping connected to the exchangers entry.

Installation

Before any operation please check the instruction for use.

Warning

Installation and maintenance are to be performed only by qualified personnel who are familiar with local codes and regulations, and who are experienced with this type of equipment. Must be avoided the installation of the unit in places that could be considered dangerous for maintenance operations.

Transport

It is necessary to be sure of the stability of the unit during transportation. Therefore the unit is supplied with a transversal wooden beam placed on the unit base that must to be removed only after the final destination. In case the unit has to be moved again, a similar solution is necessary.

Handling and lifting

Care should be taken to avoid rough handling or shock due to the unit drop. Do not push or pull the unit from anything else than the base, and block the pushing vehicle away from the unit to prevent damage to the sheetmetal cabinet and end frame (see Figure 1).

Never allow any part of the unit to fall during unloading or moving as this may result in serious damage.

To lift the unit suitable holes are provided in unit base and spreader bars and cables should be used to prevent damage to the condenser coils or cabinet (see Figure 2).

BLOCKING REQ'D ACROSS FULL WIDTH

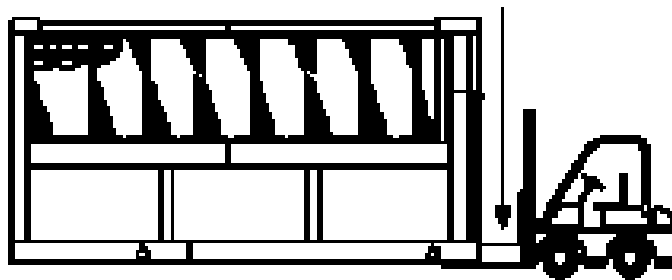

Fig. 1 - Suggested pushing arrangement

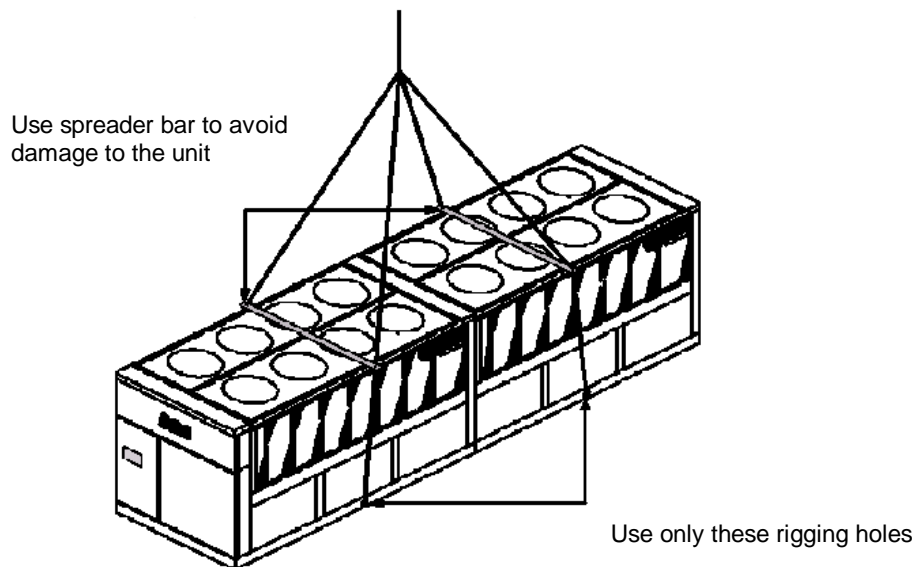

Fig. 2 – Suggested lifting arrangement

Location

The ALS units are produced for outside installation on roofs, floors or below ground level on condition that the area is free from obstacles for the passage of the condenser air. The unit should be positioned on solid foundations and perfectly level; in the case of installation on roofs or floors, it may be advisable to arrange the use of suitable weight distribution beams. When the units are installed on the ground, a concrete base at least 250 mm wider and longer than the unit's footprint should be laid. Furthermore, this base should withstand the unit weight mentioned in the technical data table. When the units are positioned in areas which are easily accessible by persons or animals, it is advisable to fit guards to protect the condenser coil guards and, when necessary, also guards to protect the evaporator area.

Besides to obtain the best performance the location area it is necessary to follow the next precaution and advise:

- Avoid air flow recirculation.
- Take care that obstacles do not obstruct air flow.
- A free air flow is required to ensure the right air suction and delivery.
- To reduce noise and vibration a stiff floor is required.
- To avoid that condenser coils get dirty avoid dusty ambient.
- Chiller water must be quite clean and all trace of oil and rust particles removed. It is necessary to fit a water filter on the entering water pipes.

Space requirements

The ALS units are air-cooled, hence it is important to observe the minimum distances which guarantee the best ventilation of the condenser coils. Limitations of space reducing the air flow could cause significant reductions in cooling capacity and an increase in electricity consumption.

To determinate unit placement, careful consideration must be given to assure a sufficient air flow across the condenser heat transfer surface. Two conditions must be avoided to achieve the best performance: warm air recirculation and coil starvation.

Both these conditions cause an increase of condensing pressures that results in reductions in unit efficiency and capacity. The ALS chiller performance is less affected in poor air flow situations because of its special condensing coil geometry.

Moreover McQuay's unique microprocessor has the ability to calculate the operating environment of the chiller and the capacity to optimize its performance staying on-line during abnormal conditions.

Each side of the unit must be accessible after installation for periodic service. Fig.3 shows you minimum recommended clearance requirements.

Vertical condenser air discharge must be unobstructed because the unit would have its capacity and efficiency significantly reduced.

If the units are positioned in places surrounded by walls or obstacles of the same height as the units, the units should be at least 2500 mm from obstacles (fig.4). In the event the obstacles are higher than the units, the units should be at least 3000 mm from the obstacle (fig.5). Units installed closer than the minimum recommended distance to a wall or other vertical riser may experience a combination of coil starvation and warm air recirculation, thus causing reduction in unit capacity and efficiency reductions. Once again, the microprocessor will allow the chiller to stay on line, producing the maximum available capacity, even at less than recommended lateral clearances.

When two or more units are positioned side by side it is recommended that the condenser coils are at least 3600 mm distance from one another (fig.6).

For other installation solutions, consult McQuay technicians.

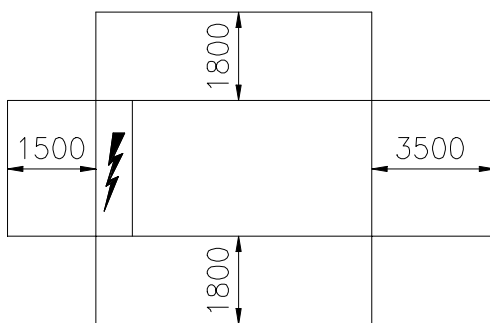

Figure 3

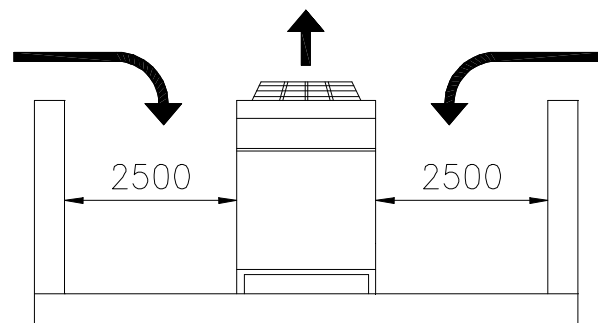

Figure 4

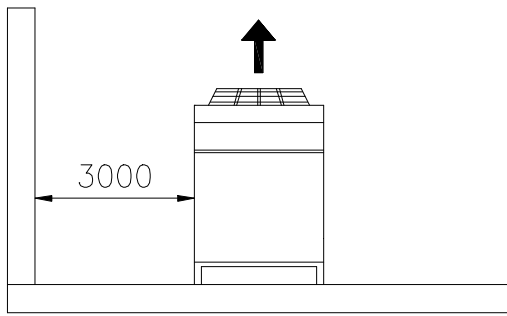

Figure 5

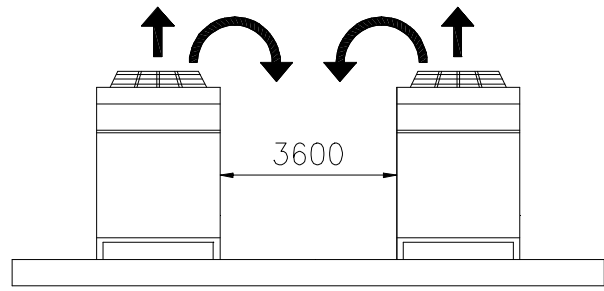

Figure 6

Acoustic protection

When the noise level must meet special requirements it will be necessary to pay the maximum attention to ensure the perfect insulation of the unit from the support base by applying appropriate vibration-dampening devices, applying vibration-dampening mounts on the water pipes and on the electrical connections.

Water piping

Due to the variety of piping practices, it is advisable to follow the recommendations of local authorities. They can supply the installer with the proper building and safety codes required for a safe and proper installation.

Basically, the piping should be designed with a minimum number of bends and changes in elevation to keep system cost down and performance up. It should contain:

1. Vibration eliminators to reduce vibration and noise transmission to the building.
2. Shutoff valves to isolate the unit from the piping system during unit servicing.
3. Manual or automatic air vent valves at the high points of the system. Drains at the low parts in the system. The evaporator should not be the highest point in the piping system.
4. Some means of maintaining adequate system water pressure (e.g., expansion tank or regulating valve).
5. Water temperature and pressure indicators located at the unit to aid in unit servicing.
6. A strainer or some means of removing foreign matter from the water before it enters the pump. The strainer should be placed far enough upstream to prevent cavitation at the pump inlet (consult pump manufacturer for recommendations). The use of a strainer will prolong pump life and help maintain high system performance levels.
7. A strainer should also be placed in the supply water line just prior to the inlet of the evaporator. This will aid in preventing foreign material from entering and decreasing the performance of the evaporator.
8. The shell-and-tube evaporator has a thermostat and heating cable to prevent freeze-up down to -28°C. Any water piping to the unit must also be protected to prevent freezing.
9. If the unit is used as a replacement chiller on a previously existing piping system, the system should be thoroughly flushed prior to unit installation and then regular chilled water analysis and chemical water treatment is recommended immediately at equipment start-up.
10. In the event glycol is added to the water system, as an afterthought for freeze protection, recognize that the refrigerant suction pressure will be lower, cooling performance less, and water side pressure drop greater. System safety devices such as freeze protection and low pressure protection must be reset.

Prior to insulating the piping and filling the system, a preliminary leak check should be made.

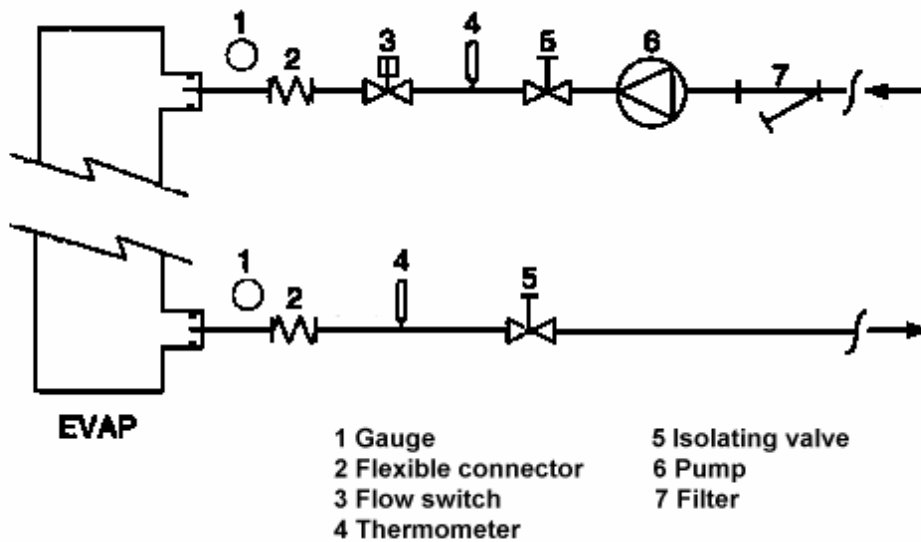

Figure 7 - Typical chilled water piping connection scheme

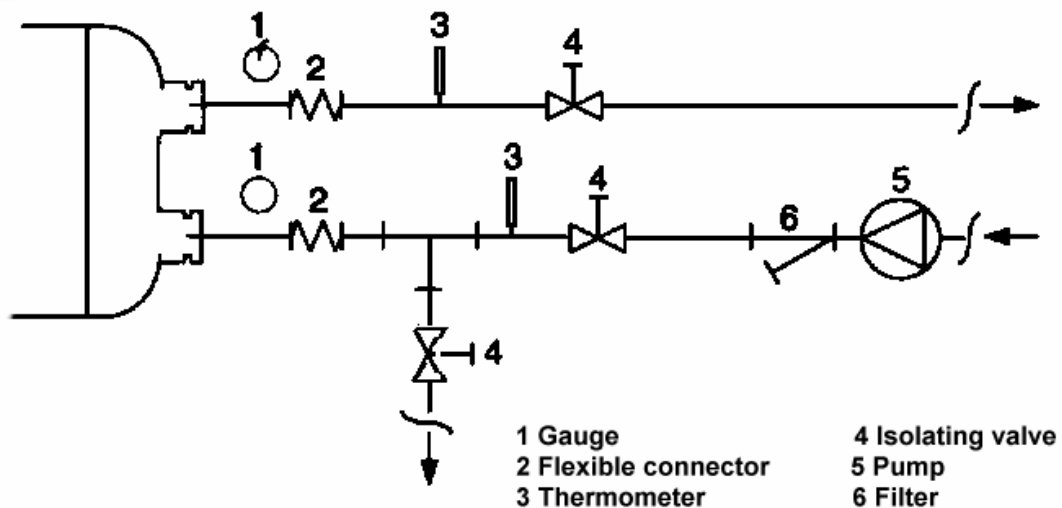

Figure 8 - Typical heat recovery piping connection scheme

Evaporator Freeze Protection

All evaporators come equipped with thermostatically controlled heat tapes that provide freeze protection down to -28°C. However, this should not be the only method of freeze protection. Unless the evaporator is flushed and drained as is described below in note 4, two or more of the remaining three recommendations must be followed as part of the system design:

1. Continuous circulation of water through the piping and the heat exchanger.
2. The inclusion of glycol solution in the chilled water circuit.
3. The addition of insulation and heat to the exposed piping.
4. Draining and flushing the chiller vessel with glycol during subfreezing weather.

It is the responsibility of the installing contractor and/or on-site maintenance personnel to insure that this additional protection is provided. Routine checks should be made to insure adequate freeze protection is maintained. Failure to do so may result in damage to unit components. Freeze damage is not considered a warranty failure.

Flow Switch

A water flow switch must be mounted in either the entering or leaving water line to insure that there will be adequate water flow to the evaporator before the unit can start. This will safeguard against slugging the compressors on start-up. It also serves to shut down the unit in the event that water flow is interrupted to guard against evaporator freeze-up. A flow switch is available from McQuay and it is a "paddle" type switch and adaptable to any pipe size from 1" (25mm) to 8" (203mm) nominal.

Certain minimum flow rates are required to close the switch and are listed in Table 1.

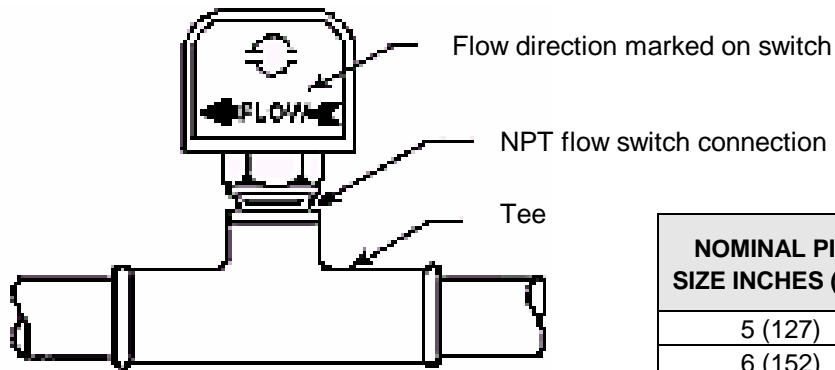

Figure 7 – Flow Switch

| NOMINAL PIPE SIZE INCHES (mm) | MINIMUM REQUIRED FLOW TO ACTIVATE SWITCH (LITERS PER SECONDS) |
|-------------------------------|---|
| 5 (127) | 3.7 |
| 6 (152) | 5.0 |
| 8 (203) | 8.8 |

Table 1

Operating limits – ALS SE

| Unit version | | ST/CN | LN | XN | XXN |
|---|----|-------|------|------|------|
| Max ambient temperature | °C | + 45 | + 40 | + 40 | + 40 |
| Min ambient temperature (1) | °C | + 10 | + 5 | + 5 | + 5 |
| Max entering evaporator water temperature | °C | + 20 | + 20 | + 20 | + 20 |
| Min leaving evap. water temp.(without glycol) | °C | + 4 | + 4 | + 4 | + 4 |
| Min leaving evap. water temp.(with glycol) | °C | - 8 | - 8 | - 8 | - 8 |
| Max evaporator ? T | °C | 8 | 8 | 8 | 8 |
| Min evaporator ? T | °C | 4 | 4 | 4 | 4 |

Note: (1) When air temperature is lower than +10°C (ST – CN) or +5°C (LN – XN – XXN) you need the fan speed control device. It allows the unit working with air temperature down to –18°C.

Operating limits – ALS XE

| Unit version | | ST/CN | LN | XN |
|---|----|-------|------|------|
| Max ambient temperature | °C | + 50 | + 45 | + 45 |
| Min ambient temperature (1) | °C | + 10 | + 5 | + 5 |
| Max entering evaporator water temperature | °C | + 20 | + 20 | + 20 |
| Min leaving evap. water temp.(without glycol) | °C | + 4 | + 4 | + 4 |
| Min leaving evap. water temp.(with glycol) | °C | - 8 | - 8 | - 8 |
| Max evaporator ? T | °C | 8 | 8 | 8 |
| Min evaporator ? T | °C | 4 | 4 | 4 |

Note: (1) When air temperature is lower than +10°C (ST – CN) or +5°C (LN – XN) you need the fan speed control device. It allows the unit working with air temperature down to –18°C.

Operating limits – ALS HA

| Unit version | | ST/CN |
|---|----|-------|
| Max ambient temperature | °C | + 50 |
| Min ambient temperature | °C | + 10 |
| Max entering evaporator water temperature | °C | + 20 |
| Min leaving evap. water temp.(without glycol) | °C | + 4 |
| Min leaving evap. water temp.(with glycol) | °C | - 8 |
| Max evaporator ? T | °C | 8 |
| Min evaporator ? T | °C | 4 |

Physical data ALS SE ST / CN HFC 134a

| ALS Unit Size | | 081.2 | 094.2 | 101.2 | 114.2 | 125.2 | 142.2 |
|-----------------------------|-----|-------|-------|-------|-------|-------|-------|
| Cooling capacity (1) | kW | 301,1 | 347,0 | 370,7 | 408,0 | 452,0 | 524,8 |
| Power input (1) | kW | 114,6 | 117,5 | 131,1 | 147,2 | 164,4 | 173,4 |
| COP | | 2,63 | 2,95 | 2,83 | 2,77 | 2,75 | 3,02 |
| McQuay Screw compressors | No. | 2 | 2 | 2 | 2 | 2 | 2 |
| Refrigerant circuits | No. | 2 | 2 | 2 | 2 | 2 | 2 |
| Refrigerant charge HFC 134a | kg | 70 | 70 | 80 | 80 | 100 | 100 |
| Oil charge | l | 20 | 20 | 20 | 20 | 20 | 20 |
| Min % of capacity reduction | % | 12,5% | 12,5% | 12,5% | 12,5% | 12,5% | 12,5% |

Condenser fans

| | | | | | | | |
|---------------------------------|-------------------|---------|---------|---------|---------|---------|---------|
| No. of fans / nominal power fan | kW | 4 / 1,6 | 6 / 1,6 | 6 / 1,6 | 6 / 1,6 | 6 / 1,6 | 8 / 1,6 |
| Fan speed | rpm | 900 | 900 | 900 | 900 | 900 | 900 |
| Diameter | mm | 800 | 800 | 800 | 800 | 800 | 800 |
| Total air flow | m ³ /s | 21,7 | 33,8 | 33,8 | 33,2 | 32,6 | 45,0 |

Evaporator

| | | | | | | | |
|----------------------------|-------|---------|---------|---------|---------|---------|---------|
| Evaporators / water volume | No./l | 1 / 198 | 1 / 181 | 1 / 181 | 1 / 181 | 1 / 227 | 1 / 273 |
| Max operating pressure | bar | 10,5 | 10,5 | 10,5 | 10,5 | 10,5 | 10,5 |
| Water connection diameter | mm | 139,7 | 139,7 | 139,7 | 139,7 | 139,7 | 139,7 |

Condenser coil

| | | | | | | | |
|-----------|---|--|--|--|--|--|--|
| Coil type | Lanced fins – Internally spiral wound tubes | | | | | | |
|-----------|---|--|--|--|--|--|--|

Weight and dimensions

| | | | | | | | |
|---------------------------------------|----|------|------|------|------|------|------|
| Standard unit shipping weight | kg | 3250 | 3515 | 3515 | 3515 | 3565 | 3895 |
| Standard unit shipping weight (CN) | kg | 3510 | 3775 | 3775 | 3775 | 3825 | 4195 |
| Standard unit operating weight | kg | 3448 | 3696 | 3696 | 3696 | 3792 | 4168 |
| Standard unit operating weight (CN) | kg | 3708 | 3956 | 3956 | 3956 | 4052 | 4468 |
| Unit length | mm | 2790 | 3460 | 3460 | 3460 | 3460 | 4355 |
| Unit width | mm | 2225 | 2225 | 2225 | 2225 | 2225 | 2225 |
| Unit height | mm | 2500 | 2500 | 2500 | 2500 | 2500 | 2500 |

Note: (1) Nominal cooling capacity and power input are based on: 12/7 °C entering/leaving evaporator water temperature; 35°C ambient temperature. The power input is for compressor only.

Electrical data ALS SE ST / CN HFC 134a

| ALS Unit Size | | 081.2 | 094.2 | 101.2 | 114.2 | 125.2 | 142.2 |
|---------------------------------------|---|---------------------|-------|-------|-------|-------|-------|
| Standard voltage (1) | | 400 V – 3ph – 50 Hz | | | | | |
| Nominal unit current (2) | A | 201 | 205 | 223 | 247 | 270 | 285 |
| Max compressor current (3) | A | 241 | 247 | 273 | 305 | 335 | 369 |
| Fans current | A | 20 | 30 | 30 | 30 | 30 | 40 |
| Max unit current (3) | A | 261 | 277 | 303 | 335 | 365 | 409 |
| Max unit inrush current (4) | A | 386 | 390 | 395 | 399 | 412 | 418 |
| Max unit current for wires sizing (5) | A | 270 | 300 | 320 | 350 | 380 | 390 |

Notes: (1) Allowed voltage tolerance $\pm 10\%$. Voltage unbalance between phases must be within $\pm 3\%$.

(2) Nominal current are based on: 12/7 °C entering/leaving evaporator water temperature and 35°C ambient temp.

(3) Maximum current are based on: 15/10 °C entering/leaving evaporator water temperature and 45°C ambient temp.

(4) Inrush current of biggest compressor + 75% of nominal absorbed current of the other compressor (see pag. 4 "Intelligent Start Compressor Mode") + fans current.

(5) Compressor FLA + fans current.

Physical data ALS SE LN / XN HFC 134a

| ALS Unit Size | | 081.2 | 094.2 | 101.2 | 114.2 | 125.2 | 142.2 |
|-----------------------------|-----|-------|-------|-------|-------|-------|-------|
| Cooling capacity (1) | kW | 287,4 | 337,3 | 359,4 | 402,7 | 433,2 | 512,6 |
| Power input (1) | kW | 123,0 | 123,7 | 138,6 | 158,8 | 176,5 | 186,1 |
| COP | | 2,34 | 2,73 | 2,59 | 2,54 | 2,45 | 2,75 |
| McQuay Screw compressors | No. | 2 | 2 | 2 | 2 | 2 | 2 |
| Refrigerant circuits | No. | 2 | 2 | 2 | 2 | 2 | 2 |
| Refrigerant charge HFC 134a | kg | 70 | 70 | 80 | 80 | 100 | 100 |
| Oil charge | l | 20 | 20 | 20 | 20 | 20 | 20 |
| Min % of capacity reduction | % | 12.5% | 12.5% | 12.5% | 12.5% | 12.5% | 12,5% |

Condenser fans

| | | | | | | | |
|---------------------------------|-------------------|-------|-------|-------|-------|-------|-------|
| No. of fans / nominal power fan | kW | 4 / 1 | 6 / 1 | 6 / 1 | 6 / 1 | 6 / 1 | 8 / 1 |
| Fan speed | rpm | 700 | 700 | 700 | 700 | 700 | 700 |
| Diameter | mm | 800 | 800 | 800 | 800 | 800 | 800 |
| Total air flow | m ³ /s | 17,3 | 27 | 27 | 26,5 | 25,9 | 36,0 |

Evaporator

| | | | | | | | |
|----------------------------|-------|---------|---------|---------|---------|---------|---------|
| Evaporators / water volume | No./l | 1 / 198 | 1 / 181 | 1 / 181 | 1 / 181 | 1 / 227 | 1 / 273 |
| Max operating pressure | bar | 10,5 | 10,5 | 10,5 | 10,5 | 10,5 | 10,5 |
| Water connection diameter | mm | 139,7 | 139,7 | 139,7 | 139,7 | 139,7 | 139,7 |

Condenser coil

| | | | | | | | |
|-----------|---|--|--|--|--|--|--|
| Coil type | Lanced fins – Internally spiral wound tubes | | | | | | |
|-----------|---|--|--|--|--|--|--|

Weight and dimensions

| | | | | | | | |
|---------------------------------------|----|------|------|------|------|------|------|
| Standard unit shipping weight | kg | 3250 | 3515 | 3515 | 3515 | 3565 | 3895 |
| Standard unit shipping weight (XN) | kg | 3510 | 3775 | 3775 | 3775 | 3825 | 4195 |
| Standard unit operating weight | kg | 3448 | 3696 | 3696 | 3696 | 3792 | 4168 |
| Standard unit operating weight (XN) | kg | 3708 | 3956 | 3956 | 3956 | 4052 | 4468 |
| Unit length | mm | 2790 | 3460 | 3460 | 3460 | 3460 | 4355 |
| Unit width | mm | 2225 | 2225 | 2225 | 2225 | 2225 | 2225 |
| Unit height | mm | 2500 | 2500 | 2500 | 2500 | 2500 | 2500 |

Note: (1) Nominal cooling capacity and power input are based on: 12/7 °C entering/leaving evaporator water temperature; 35°C ambient temperature. The power input is for compressor only.

Electrical data ALS SE LN / XN HFC 134a

| ALS Unit Size | | 081.2 | 094.2 | 101.2 | 114.2 | 125.2 | 142.2 |
|---------------------------------------|---|---------------------|-------|-------|-------|-------|-------|
| Standard voltage (1) | | 400 V – 3ph – 50 Hz | | | | | |
| Nominal unit current (2) | A | 212 | 213 | 234 | 262 | 288 | 304 |
| Max compressor current (3) | A | 237 | 240 | 264 | 297 | 328 | 354 |
| Fans current | A | 20 | 30 | 30 | 30 | 30 | 40 |
| Max unit current (3) | A | 257 | 270 | 294 | 327 | 358 | 394 |
| Max unit inrush current (4) | A | 390 | 394 | 399 | 403 | 419 | 425 |
| Max unit current for wires sizing (5) | A | 270 | 300 | 320 | 350 | 380 | 390 |

Notes: (1) Allowed voltage tolerance $\pm 10\%$. Voltage unbalance between phases must be within $\pm 3\%$.

(2) Nominal current are based on: 12/7 °C entering/leaving evaporator water temperature and 35°C ambient temp.

(3) Maximum current are based on: 15/10 °C entering/leaving evaporator water temperature and 40°C ambient temp.

(4) Inrush current of biggest compressor + 75% of nominal absorbed current of the other compressor (see pag. 4 "Intelligent Start Compressor Mode") + fans current.

(5) Compressor FLA + fans current.

Physical data ALS SE XXN HFC 134a

| ALS Unit Size | | 081.2 | 094.2 | 101.2 | 114.2 | 125.2 | 142.2 |
|-----------------------------|-----|-------|-------|-------|-------|-------|-------|
| Cooling capacity (1) | kW | 294,1 | 330,7 | 363,3 | 409,5 | 447,8 | 516,9 |
| Power input (1) | kW | 118,6 | 127,7 | 136,0 | 149,4 | 161,5 | 189,0 |
| COP | | 2,48 | 2,59 | 2,67 | 2,74 | 2,77 | 2,74 |
| McQuay Screw compressors | No. | 2 | 2 | 2 | 2 | 2 | 2 |
| Refrigerant circuits | No. | 2 | 2 | 2 | 2 | 2 | 2 |
| Refrigerant charge HFC 134a | kg | 70 | 70 | 80 | 80 | 100 | 100 |
| Oil charge | l | 20 | 20 | 20 | 20 | 20 | 20 |
| Min % of capacity reduction | % | 12.5% | 12.5% | 12.5% | 12.5% | 12.5% | 12,5% |

Condenser fans

| No. of fans / nominal power fan | kW | 6 / 0,74 | 7 / 0,74 | 8 / 0,74 | 9 / 0,74 | 10 / 0,74 | 10 / 0,74 |
|---------------------------------|-------------------|----------|----------|----------|----------|-----------|-----------|
| Fan speed | rpm | 500 | 500 | 500 | 500 | 500 | 500 |
| Diameter | mm | 800 | 800 | 800 | 800 | 800 | 800 |
| Total air flow | m ³ /s | 19,3 | 22,5 | 25,7 | 26,3 | 26,9 | 32,1 |

Evaporator

| | | | | | | | |
|----------------------------|-------|---------|---------|---------|---------|---------|---------|
| Evaporators / water volume | No./l | 1 / 192 | 1 / 192 | 1 / 190 | 1 / 225 | 1 / 221 | 1 / 265 |
| Max operating pressure | bar | 10,5 | 10,5 | 10,5 | 10,5 | 10,5 | 10,5 |
| Water connection diameter | mm | 139,7 | 139,7 | 139,7 | 139,7 | 139,7 | 139,7 |

Condenser coil

| | | | | | | | |
|-----------|---|--|--|--|--|--|--|
| Coil type | Lanced fins – Internally spiral wound tubes | | | | | | |
|-----------|---|--|--|--|--|--|--|

Weight and dimensions

| | | | | | | | |
|--------------------------------|----|------|------|------|------|------|------|
| Standard unit shipping weight | kg | 3720 | 4000 | 4110 | 4335 | 4435 | 4535 |
| Standard unit operating weight | kg | 3912 | 4192 | 4300 | 4560 | 4656 | 4800 |
| Unit length | mm | 3460 | 4355 | 4355 | 5255 | 5255 | 5255 |
| Unit width | mm | 2225 | 2225 | 2225 | 2225 | 2225 | 2225 |
| Unit height | mm | 2500 | 2500 | 2500 | 2500 | 2500 | 2500 |

Note: (1) Nominal cooling capacity and power input are based on: 12/7 °C entering/leaving evaporator water temperature; 35°C ambient temperature. The power input is for compressor only.

Electrical data ALS SE XXN HFC 134a

| ALS Unit Size | | 081.2 | 094.2 | 101.2 | 114.2 | 125.2 | 142.2 |
|---------------------------------------|---|---------------------|-------|-------|-------|-------|-------|
| Standard voltage (1) | | 400 V – 3ph – 50 Hz | | | | | |
| Nominal unit current (2) | A | 207 | 220 | 232 | 255 | 273 | 309 |
| Max compressor current (3) | A | 231 | 247 | 261 | 288 | 310 | 361 |
| Fans current | A | 30 | 35 | 40 | 45 | 50 | 50 |
| Max unit current (3) | A | 261 | 282 | 301 | 333 | 360 | 411 |
| Max unit inrush current (4) | A | 389 | 393 | 398 | 402 | 414 | 427 |
| Max unit current for wires sizing (5) | A | 280 | 305 | 330 | 365 | 400 | 400 |

Notes: (1) Allowed voltage tolerance $\pm 10\%$. Voltage unbalance between phases must be within $\pm 3\%$.

(2) Nominal current are based on: 12/7 °C entering/leaving evaporator water temperature and 35°C ambient temp.

(3) Maximum current are based on: 15/10 °C entering/leaving evaporator water temperature and 40°C ambient temp.

(4) Inrush current of biggest compressor + 75% of nominal absorbed current of the other compressor (see pag. 4 "Intelligent Start Compressor Mode") + fans current.

(5) Compressor FLA + fans current.

Physical data ALS XE ST / CN HFC 134a

| ALS Unit Size | | 081.2 | 094.2 | 101.2 | 114.2 | 125.2 | 142.2 |
|-----------------------------|-----|-------|-------|-------|-------|-------|-------|
| Cooling capacity (1) | kW | 323,2 | 366,0 | 392,6 | 456,4 | 491,6 | 546,2 |
| Power input (1) | kW | 103,8 | 115,4 | 128,8 | 135,1 | 150,5 | 158,7 |
| COP | | 3,11 | 3,17 | 3,05 | 3,38 | 3,27 | 3,44 |
| McQuay Screw compressors | No. | 2 | 2 | 2 | 2 | 2 | 2 |
| Refrigerant circuits | No. | 2 | 2 | 2 | 2 | 2 | 2 |
| Refrigerant charge HFC 134a | kg | 70 | 70 | 80 | 80 | 100 | 100 |
| Oil charge | l | 20 | 20 | 20 | 20 | 20 | 20 |
| Min % of capacity reduction | % | 12,5% | 12,5% | 12,5% | 12,5% | 12,5% | 12,5% |

Condenser fans

| No. of fans / nominal power fan | kW | 6 / 1,6 | 6 / 1,6 | 6 / 1,6 | 8 / 1,6 | 8 / 1,6 | 10 / 1,6 |
|---------------------------------|-------------------|---------|---------|---------|---------|---------|----------|
| Fan speed | rpm | 900 | 900 | 900 | 900 | 900 | 900 |
| Diameter | mm | 800 | 800 | 800 | 800 | 800 | 800 |
| Total air flow | m ³ /s | 33,8 | 32,6 | 32,6 | 46,7 | 46,7 | 56,3 |

Evaporator

| Evaporators / water volume | No./l | 1 / 181 | 1 / 227 | 1 / 227 | 1 / 205 | 1 / 205 | 1 / 265 |
|----------------------------|-------|---------|---------|---------|---------|---------|---------|
| Max operating pressure | bar | 10,5 | 10,5 | 10,5 | 10,5 | 10,5 | 10,5 |
| Water connection diameter | mm | 139,7 | 139,7 | 139,7 | 139,7 | 139,7 | 139,7 |

Condenser coil

| | | | | | | | |
|-----------|---|--|--|--|--|--|--|
| Coil type | Lanced fins – Internally spiral wound tubes | | | | | | |
|-----------|---|--|--|--|--|--|--|

Weight and dimensions

| | | | | | | | |
|---------------------------------------|----|------|------|------|------|------|------|
| Standard unit shipping weight | kg | 3515 | 3565 | 3565 | 3855 | 3855 | 4235 |
| Standard unit shipping weight (CN) | kg | 3775 | 3825 | 3825 | 4155 | 4155 | 4535 |
| Standard unit operating weight | kg | 3696 | 3792 | 3792 | 4060 | 4060 | 4500 |
| Standard unit operating weight (CN) | kg | 3956 | 4052 | 4052 | 4360 | 4360 | 4800 |
| Unit length | mm | 3460 | 3460 | 3460 | 4355 | 4355 | 5255 |
| Unit width | mm | 2225 | 2225 | 2225 | 2225 | 2225 | 2225 |
| Unit height | mm | 2500 | 2500 | 2500 | 2500 | 2500 | 2500 |

Note: (1) Nominal cooling capacity and power input are based on: 12/7 °C entering/leaving evaporator water temperature; 35°C ambient temperature. The power input is for compressor only.

Electrical data ALS XE ST / CN HFC 134a

| ALS Unit Size | | 081.2 | 094.2 | 101.2 | 114.2 | 125.2 | 142.2 |
|---------------------------------------|---|---------------------|-------|-------|-------|-------|-------|
| Standard voltage (1) | | 400 V – 3ph – 50 Hz | | | | | |
| Nominal unit current (2) | A | 186 | 202 | 219 | 235 | 259 | 262 |
| Max compressor current (3) | A | 239 | 262 | 290 | 313 | 348 | 378 |
| Fans current | A | 30 | 30 | 30 | 40 | 40 | 50 |
| Max unit current (3) | A | 269 | 292 | 320 | 353 | 388 | 428 |
| Max unit inrush current (4) | A | 381 | 385 | 393 | 397 | 408 | 412 |
| Max unit current for wires sizing (5) | A | 280 | 300 | 320 | 360 | 390 | 400 |

Notes: (1) Allowed voltage tolerance $\pm 10\%$. Voltage unbalance between phases must be within $\pm 3\%$.

(2) Nominal current are based on: 12/7 °C entering/leaving evaporator water temperature and 35°C ambient temp.

(3) Maximum current are based on: 15/10 °C entering/leaving evaporator water temperature and 50°C ambient temp.

(4) Inrush current of biggest compressor + 75% of nominal absorbed current of the other compressor (see pag. 4 "Intelligent Start Compressor Mode") + fans current.

(5) Compressor FLA + fans current.

Physical data ALS XE LN / XN HFC 134a

| ALS Unit Size | | 081.2 | 094.2 | 101.2 | 114.2 | 125.2 | 142.2 |
|-----------------------------|-----|-------|-------|-------|-------|-------|-------|
| Cooling capacity (1) | kW | 315,1 | 354,8 | 379,5 | 444,9 | 478,2 | 537,1 |
| Power input (1) | kW | 108,7 | 122,0 | 136,6 | 141,5 | 158,3 | 168,1 |
| COP | | 2,90 | 2,91 | 2,78 | 3,14 | 3,02 | 3,19 |
| McQuay Screw compressors | No. | 2 | 2 | 2 | 2 | 2 | 2 |
| Refrigerant circuits | No. | 2 | 2 | 2 | 2 | 2 | 2 |
| Refrigerant charge HFC 134a | kg | 70 | 70 | 80 | 80 | 100 | 100 |
| Oil charge | l | 20 | 20 | 20 | 20 | 20 | 20 |
| Min % of capacity reduction | % | 12,5% | 12,5% | 12,5% | 12,5% | 12,5% | 12,5% |

Condenser fans

| | | | | | | | |
|---------------------------------|-------------------|-------|-------|-------|-------|-------|--------|
| No. of fans / nominal power fan | kW | 6 / 1 | 6 / 1 | 6 / 1 | 8 / 1 | 8 / 1 | 10 / 1 |
| Fan speed | rpm | 700 | 700 | 700 | 700 | 700 | 700 |
| Diameter | mm | 800 | 800 | 800 | 800 | 800 | 800 |
| Total air flow | m ³ /s | 33,8 | 32,6 | 32,6 | 46,7 | 46,7 | 45,1 |

Evaporator

| | | | | | | | |
|----------------------------|-------|---------|---------|---------|---------|---------|---------|
| Evaporators / water volume | No./l | 1 / 181 | 1 / 227 | 1 / 227 | 1 / 205 | 1 / 205 | 1 / 265 |
| Max operating pressure | bar | 10,5 | 10,5 | 10,5 | 10,5 | 10,5 | 10,5 |
| Water connection diameter | mm | 139,7 | 139,7 | 139,7 | 139,7 | 139,7 | 139,7 |

Condenser coil

| | | | | | | | |
|-----------|---|--|--|--|--|--|--|
| Coil type | Lanced fins – Internally spiral wound tubes | | | | | | |
|-----------|---|--|--|--|--|--|--|

Weight and dimensions

| | | | | | | | |
|---------------------------------------|----|------|------|------|------|------|------|
| Standard unit shipping weight | kg | 3515 | 3565 | 3565 | 3855 | 3855 | 4235 |
| Standard unit shipping weight (XN) | kg | 3775 | 3825 | 3825 | 4155 | 4155 | 4535 |
| Standard unit operating weight | kg | 3696 | 3792 | 3792 | 4060 | 4060 | 4500 |
| Standard unit operating weight (XN) | kg | 3956 | 4052 | 4052 | 4360 | 4360 | 4800 |
| Unit length | mm | 3460 | 3460 | 3460 | 4355 | 4355 | 5255 |
| Unit width | mm | 2225 | 2225 | 2225 | 2225 | 2225 | 2225 |
| Unit height | mm | 2500 | 2500 | 2500 | 2500 | 2500 | 2500 |

Note: (1) Nominal cooling capacity and power input are based on: 12/7 °C entering/leaving evaporator water temperature; 35°C ambient temperature. The power input is for compressor only.

Electrical data ALS XE LN / XN HFC 134a

| ALS Unit Size | | 081.2 | 094.2 | 101.2 | 114.2 | 125.2 | 142.2 |
|---------------------------------------|---|---------------------|-------|-------|-------|-------|-------|
| Standard voltage (1) | | 400 V – 3ph – 50 Hz | | | | | |
| Nominal unit current (2) | A | 193 | 211 | 230 | 245 | 271 | 277 |
| Max compressor current (3) | A | 230 | 254 | 282 | 300 | 335 | 357 |
| Fans current | A | 30 | 30 | 30 | 40 | 40 | 50 |
| Max unit current (3) | A | 260 | 284 | 312 | 340 | 375 | 407 |
| Max unit inrush current (4) | A | 383 | 387 | 397 | 400 | 413 | 415 |
| Max unit current for wires sizing (5) | A | 280 | 300 | 320 | 360 | 390 | 400 |

Notes: (1) Allowed voltage tolerance $\pm 10\%$. Voltage unbalance between phases must be within $\pm 3\%$.

(2) Nominal current are based on: 12/7 °C entering/leaving evaporator water temperature and 35°C ambient temp.

(3) Maximum current are based on: 15/10 °C entering/leaving evaporator water temperature and 45°C ambient temp.

(4) Inrush current of biggest compressor + 75% of nominal absorbed current of the other compressor (see pag. 4 "Intelligent Start Compressor Mode") + fans current.

(5) Compressor FLA + fans current.

Physical data ALS HA HFC 134a

| ALS Unit Size | | 081.2 | 094.2 | 101.2 | 114.2 | 125.2 | 142.2 |
|-----------------------------|-----|-------|-------|-------|-------|-------|-------|
| Cooling capacity (1) | kW | 318,3 | 353,1 | 378,0 | 444,2 | 477,5 | 539,6 |
| Power input (1) | kW | 103,0 | 113,6 | 126,6 | 133,5 | 148,6 | 158,0 |
| COP | | 3,09 | 3,11 | 2,99 | 3,33 | 3,21 | 3,42 |
| McQuay Screw compressors | No. | 2 | 2 | 2 | 2 | 2 | 2 |
| Refrigerant circuits | No. | 2 | 2 | 2 | 2 | 2 | 2 |
| Refrigerant charge HFC 134a | kg | 70 | 70 | 80 | 80 | 100 | 100 |
| Oil charge | l | 20 | 20 | 20 | 20 | 20 | 20 |
| Min % of capacity reduction | % | 12,5% | 12,5% | 12,5% | 12,5% | 12,5% | 12,5% |

Condenser fans

| No. of fans / nominal power fan | kW | 6 / 1,6 | 6 / 1,6 | 6 / 1,6 | 8 / 1,6 | 8 / 1,6 | 10 / 1,6 |
|---------------------------------|-------------------|---------|---------|---------|---------|---------|----------|
| Fan speed | rpm | 900 | 900 | 900 | 900 | 900 | 900 |
| Diameter | mm | 800 | 800 | 800 | 800 | 800 | 800 |
| Total air flow | m ³ /s | 33,8 | 32,6 | 32,6 | 46,7 | 46,7 | 56,3 |

Evaporator

| Evaporators / water volume | No./l | 1 / 181 | 1 / 227 | 1 / 227 | 1 / 205 | 1 / 205 | 1 / 265 |
|----------------------------|-------|---------|---------|---------|---------|---------|---------|
| Max operating pressure | bar | 10,5 | 10,5 | 10,5 | 10,5 | 10,5 | 10,5 |
| Water connection diameter | mm | 139,7 | 139,7 | 139,7 | 139,7 | 139,7 | 139,7 |

Condenser coil

| | |
|-----------|---|
| Coil type | Lanced fins – Internally spiral wound tubes |
|-----------|---|

Weight and dimensions

| | | | | | | | |
|--------------------------------|----|------|------|------|------|------|------|
| Standard unit shipping weight | kg | 3515 | 3565 | 3565 | 3855 | 3855 | 4235 |
| Standard unit operating weight | kg | 3696 | 3792 | 3792 | 4060 | 4060 | 4500 |
| Unit length | mm | 3460 | 3460 | 3460 | 4355 | 4355 | 5255 |
| Unit width | mm | 2225 | 2225 | 2225 | 2225 | 2225 | 2225 |
| Unit height | mm | 2500 | 2500 | 2500 | 2500 | 2500 | 2500 |

Note: (1) Nominal cooling capacity and power input are based on: 12/7 °C entering/leaving evaporator water temperature; 35°C ambient temperature. The power input is for compressor only.

Electrical data ALS HA HFC 134a

| ALS Unit Size | | 081.2 | 094.2 | 101.2 | 114.2 | 125.2 | 142.2 |
|---------------------------------------|---|---------------------|-------|-------|-------|-------|-------|
| Standard voltage (1) | | 400 V – 3ph – 50 Hz | | | | | |
| Nominal unit current (2) | A | 186 | 200 | 217 | 232 | 255 | 261 |
| Max compressor current (3) | A | 238 | 261 | 288 | 310 | 344 | 376 |
| Fans current | A | 30 | 30 | 30 | 40 | 40 | 50 |
| Max unit current (3) | A | 268 | 291 | 318 | 350 | 384 | 426 |
| Max unit inrush current (4) | A | 381 | 385 | 392 | 393 | 407 | 410 |
| Max unit current for wires sizing (5) | A | 280 | 300 | 320 | 360 | 390 | 400 |

Notes: (1) Allowed voltage tolerance $\pm 10\%$. Voltage unbalance between phases must be within $\pm 3\%$.

(2) Nominal current are based on: 12/7 °C entering/leaving evaporator water temperature and 35°C ambient temp.

(3) Maximum current are based on: 15/10 °C entering/leaving evaporator water temperature and 50°C ambient temp.

(4) Inrush current of biggest compressor + 75% of nominal absorbed current of the other compressor (see pag. 4 "Intelligent Start Compressor Mode") + fans current.

(5) Compressor FLA + fans current.

Evaporator Pressure Drop ALS 081.2 – 142.2

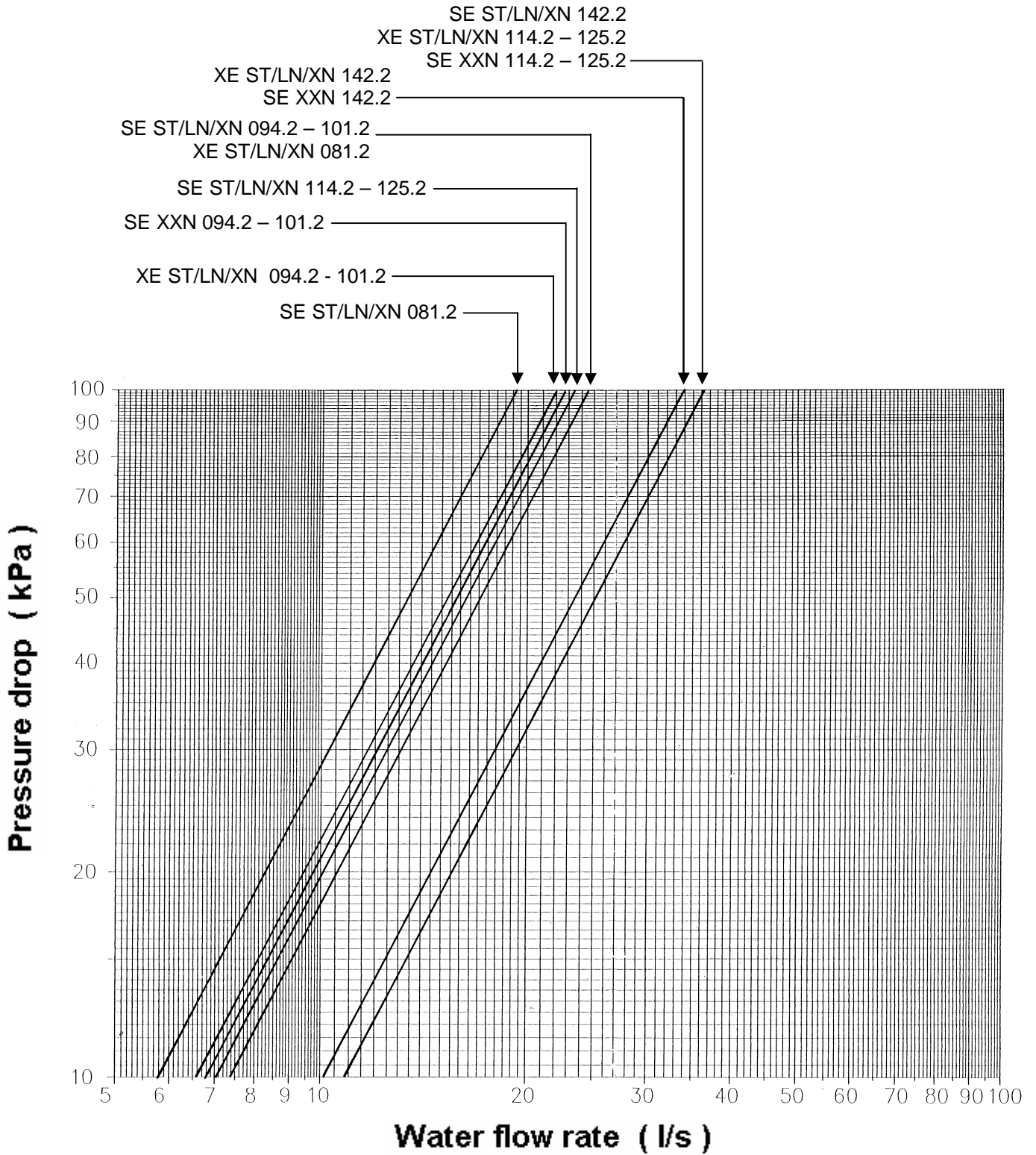

Evaporator water flow

Balance the chilled water flow through the evaporator. The flow rates must fall between the minimum and maximum values. Flow rates below the minimum values shown will result in laminar flow that will reduce efficiency, cause erratic operation of the electronic expansion valve and could cause low temperature cutouts. On the other hand flow rates exceeding the maximum values shown can cause erosion on the evaporator water connections and tubes. Measure the chilled water pressure drop through the evaporator at field installed pressure taps. It is important not to include valve or strainer pressure drop in these readings. Variable chilled water flow through the evaporator while the compressors are operating is not recommended. Set points are based upon a constant flow and variable temperature.

| Size ALS SE | Min. water flow (l/s) | Max. water flow (l/s) | Size ALS XE | Min. water flow (l/s) | Max. water flow (l/s) |
|--------------|-----------------------|-----------------------|--------------|-----------------------|-----------------------|
| 081.2 | 8.9 | 17.2 | 081.2 | 9.6 | 18.5 |
| 094.2 | 10.4 | 19.9 | 094.2 | 10.9 | 20.9 |
| 101.2 | 11.1 | 21.3 | 101.2 | 11.7 | 22.5 |
| 114.2 | 12.2 | 23.4 | 114.2 | 13.6 | 26.1 |
| 125.2 | 13.5 | 25.9 | 125.2 | 14.7 | 28.2 |
| 142.2 | 15.6 | 30.0 | 142.2 | 16.3 | 31.3 |

Screw compressors

The newest Stargate™ single-screw compressor has a well balanced compression mechanism which cancels the screw rotor load in both the radial and axial directions. Inherent to the basic single-screw compressor design is the virtually load-free operation, that gives main bearing design life of 3-4 times greater than twin-screws, and eliminates expensive and complicated thrust balancing schemes. The two exactly opposed gaterotors create two exactly opposed compression cycles. Compression is made at the lower and upper parts of the screw rotor at the same time, thus cancelling the radial loads. Also, both ends of the screw rotor are subjected to suction pressure only, which cancels the axial loads and eliminates the huge thrust loads inherent in twin-screw compressors.









Oil injection is used for these compressors in order to get high COP at high condensing pressure.

Compressors have a infinitely variable capacity control down to 25% of its total capacity. This control is made by means of capacity slides controlled by microprocessors.

Standard start is star-delta type; Soft start type is available (as option) in order to have lower inrush current and to guarantee a soft compressor start.

ALS 081.2÷142.2 SE/XE ST LN XN XXN

LEGEND

-  2 WAY SHUT-OFF VALVE
-  RELIEF VALVE
-  LIQUID INJECTION SOLENOID VALVE
-  SLIGHT GLASS
-  1/4" SAE FLARE VALVE
-  LOW PRESSURE SWITCH
-  HIGH PRESSURE SWITCH
-  OPTIONAL
-  EEXV ELECTRONIC EXPANSION VALVE

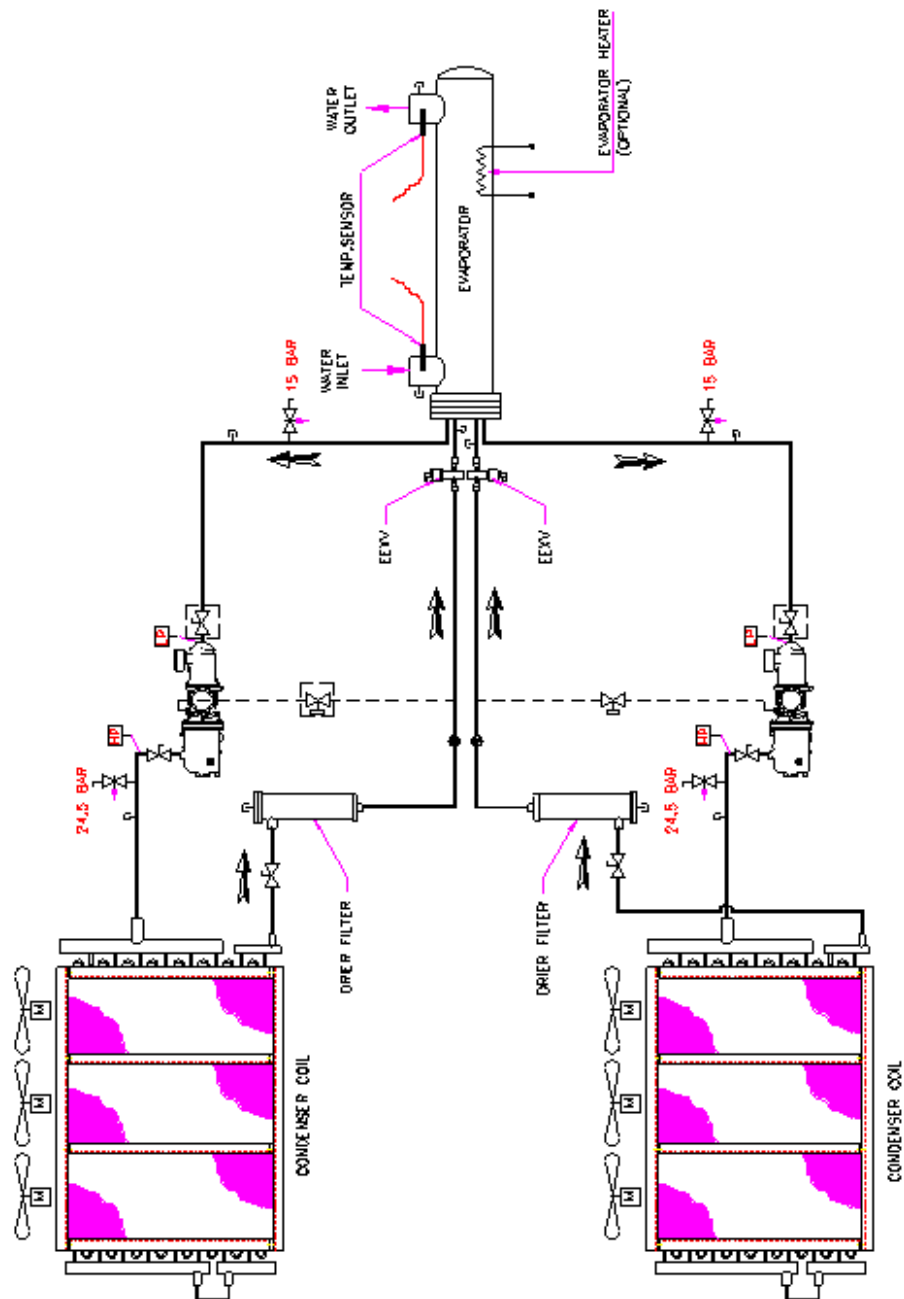

Standard controls

High pressure control

The high pressure switch will shut-down the compressor when the discharge pressure exceeds the setting point value.

Checking control operation:

1. To check the control, either block off condenser surface or start the unit with condenser fan motor fuses in only one fan fuse block and observe the cut out point of the control on a high pressure gauge.
2. Observe the discharge pressure gauge: when the pressure reaches the control cut-out point, this control should stop the compressor.

Warning: during testing, stand by the emergency stop switch Q11 on control panel, to shut the unit down should the safety control malfunction. Be sure that the installed gauge is accurately adjusted.

Phase/voltage monitor

The phase/voltage monitor is a device which provides protection against three-phase electrical motor loss due to power failure conditions and phase reversal. Whenever any of these conditions occur, a contact opens to the microprocessor which then de-energizes all inputs. When proper power is restored, contacts close and microprocessor enables compressors for operation. When three-phase power has been applied, the output relay should close and the "run light" should come on. If the output relay does not close, perform the following tests:

using a phase tester, verify that phases are in R, S, T sequence for L1, L2 and L3. Correct rotation is required for compressor operation. If required to do so by phase sequence, turn off the power and interchange any two of the supply power leads at the disconnect. This may be necessary as the phase voltage monitor is sensitive to phase reversal. Turn on the power. The output relay should now close after the appropriate delay.

System Maintenance

General

To ensure proper operation at peak capacity and to avoid damage to package components, a program of periodic inspections should be set up and followed. The following items are intended as a guide and are to be used during inspection and must be combined with sound refrigeration and electrical practices to ensure trouble-free performance. The liquid line sightglass indicator on all circuits must be checked to be sure the glass is full and clear. If the indicator shows that a wet condition exists or if bubbles show in the glass, even with a full refrigerant charge, the filter-drier element must be changed.

Compressor maintenance

The screw Frame 4 compressor does not require frequent maintenance. However, vibration is an excellent check for proper mechanical operation. Compressor vibration is an indicator of the requirement for maintenance and contributes to a decrease in unit performance and efficiency. It is recommended that the compressor be checked with a vibration analyzer at or shortly after start-up and again on an annual basis. When performing the test the load should be maintained as closely as possible to the load of the original test. The vibration analyzer test provides a fingerprint of the compressor and when performed routinely can give a warning of impending problems.

Electrical control centre

Warning: Electric shock hazard. Turn off all power before continuing with following service.

Caution: It is necessary to de-energize the complete panel, including crankcase heater, before doing any servicing inside.

Prior to attempting any service on the control centre it is advisable to study the wiring diagram so that you understand the operation of the water chiller. Electrical components do not require particular maintenance other than a monthly tightening of cables.

Warning: The warranty becomes void if the wiring is not in accordance with the specification. A blown fuse or tripped protector indicates a short ground or overload.

Before replacing the fuse or restarting the compressor, the problem must be found and corrected. It is important to have a qualified control panel electrician service this panel. Unqualified tampering with the controls can cause serious damage to equipment and void the warranty.

Refrigerant sightglass

The refrigerant sightglasses should be observed periodically (a weekly observation should be adequate). A clear glass of liquid indicates that there is adequate refrigerant charge in the system to insure proper feed through the expansion valve. Bubbling refrigerant in the sightglass, during stable run conditions, indicates that the system may be short of refrigerant charge. Refrigerant gas flashing in the sightglass could also indicate an excessive pressure drop in the liquid line, possibly due to a clogged filter-drier or a restriction elsewhere in the liquid line. If subcooling is low add charge to clear the sightglass. If subcooling is normal and flashing is visible in the sightglass check the pressure drop across the filter-drier. An element inside the sightglass indicates the moisture condition corresponding to a given element color. If the sightglass does not indicate a dry condition after about 3 hours of operation, the unit should be pumped down and the filter-driers changed.

The following table is a guide to determinate the dry or wet condition of the system:

| COLOUR | MEANS |
|------------------|-------|
| Green (Sky Blue) | Dry |
| Yellow (Pink) | Wet |

Filter-driers

A replacement of the filter-drier is recommended during scheduled service maintenance of the unit, any time excessive pressure drop is read across the filter-drier and/or when bubbles occur in the sightglass with normal subcooling. The maximum recommended pressure drop across the filter-drier at 75% to 100% circuit loading is 70 kPa. The maximum recommended pressure drop across the filter-drier at 25% to 50% circuit loading is 35 kPa. The filter-drier should also be changed if the moisture indicating liquid line sightglass indicates excess moisture by the wet system color indicators. During the first few months of operation the filter-drier replacement may be necessary if the pressure drop across the filter-drier exceeds the values listed in the paragraph above. Any residual particles from the unit heat transfer tubing, compressor and miscellaneous components are swept by the refrigerant into the liquid line and are caught by the filter-drier.

To change the filter drier, pump the unit down by opening the switches Q1, Q2 (ON/OFF switches compressors) in "off" position.

Move the ON/OFF switch unit Q0 to the "off" position. Turn off all power to the unit and install jumpers across the terminals F12, F22.

This jumps out the low pressure control. Close the manual liquid line shutoff valve.

Turn the power of the unit back on and restart the unit by moving the ON/OFF switch unit Q0. The unit will start pumping down past the low pressure setting.

When the evaporator pressure reaches 0,3 bar, move switch Q0 to the "off" position. Remove the jump.

Close the suction line valve. Remove and replace the filter-drier. Evacuate the lines through the application of a vacuum pump to remove non condensables that may have entered during filter replacement.

Open the suction line valve. A leak check is recommended before returning the unit to operation.

Electronic expansion valve

ALS air cooled chiller is equipped with the most advanced electronic expansion valve to achieve precise control of refrigerant mass flow. As today's system requires improved energy efficiency, tighter temperature control, wider range of operating conditions and incorporate new features like remote monitoring and diagnostics, the application of electronic expansion valves becomes mandatory. ALS's electronic expansion valve proposes features that makes it unique: short opening and closing time, high resolution, positive shut-off function to eliminate use of additional solenoid valve, highly linear flow capacity, continuous modulation of mass flow without stress in the refrigerant circuit and corrosion resistance stainless steel body.

Evaporator

The evaporator is of the direct expansion, shell-and-tube type with refrigerant flowing through the tubes and water flowing through the shell over the tubes. The tubes are internally finned to provide extended surface as well as turbulent flow of refrigerant through the tubes. Normally no service work is required on the evaporator.

Air cooled condenser (Condensing coil)

Condensers are air cooled. Internally finned copper tubes bonded in a staggered pattern into slit aluminium fins. No maintenance is ordinary required except the occasional removal of dirt and debris from the outside surface of the fins. McQuay recommends the use of foaming coil cleaners available at air conditioning supply outlets. Use caution when selecting such cleaners as some may contain potentially harmful chemicals. Care should be taken not to damage the fins during cleaning.

Lubricating oils

Besides lubricating the bearing and other moving parts, the oil has the equally important task of sealing the clearances between the rotors and other potential leakage paths thereby improving pumping efficiency; the oil also assists in dissipating the heat of compression. The amount of oil injected is therefore well in excess of that required for lubrication alone.

Lubricating oil approved for use with McQuay Screw compressor is POE Emkarate RL68H.

The oil differential pressure switch monitors the pressure differential between oil injection pressure and compressor suction pressure.

After the compressor has started and been in operation for a short time, allowing sufficient time for the system pressure differential to become established, the oil differential pressure switch is brought into the safety trip circuit. Oil is now being supplied to the compressor under the action of the system pressure differential. If the pressure differential falls below the switch contacts ' break ' setting and the oil differential pressure switch trips and stops the compressor.

Because the oil pressure is generated by discharge pressure, a minimum discharge pressure must be maintained; this minimum pressure increases as the suction pressure increases in order to maintain the pressure difference required.

Crankcase and integrated oil separator heaters

The function of the heaters is to prevent oil dilution with refrigerant during compressor shutdown, which would cause foaming and consequent reduction in lubricating oil flow to the moving parts. Electric heaters are energized every time the compressor shuts-down.

Warning: Verify the heaters have operated for at least 12 hours prior to start-up.

Preventive maintenance schedule

| Operation Ref. No. | TYPE OF OPERATION | PERIODICITY | | | |
|--------------------|--|-------------|---------|-------------|--------|
| | | Weekly | Monthly | Six-Monthly | Yearly |
| 1 | Reading and recording of suction pressure | X | | | |
| 2 | Reading and recording of discharge pressure | X | | | |
| 3 | Reading and recording of supply voltage | X | | | |
| 4 | Reading and recording of current intensity | X | | | |
| 5 | Check refrigerant charge and possible moisture in the circuit refrigerant through the liquid sight glass | X | | | |
| 6 | Check the suction temperature and the superheating | | X | | |
| 7 | Check setting and operation of safety devices | | X | | |
| 8 | Check setting and proper operation of control devices | | | X | |
| 9 | Inspect the condenser for possible scaling or studging | | | | X |

Refrigerant

Refrigerant charging

ALS air cooled screw chillers are shipped factory charged with a full operating charge of refrigerant but there may be times that a unit must be recharged at the jobsite. Follow these recommendations when field charging. Refer to the unit operating charge found in the physical data tables on pages from 3 to 7. The optimum charge is the charge which allows the unit to run with a solid stream of liquid in the liquid line at all operating conditions. When the liquid line temperature does not drop with the addition of 2,2-4,5 Kg of charge then the subcooler is nearly full

and proper charge has been reached. If the liquid line temperature does not drop and the discharge pressure goes up 20,7-34,5 kPa as 2,2-4,5 Kg of refrigerant is added the correct maximum charge has been reached. Unit charging can be done at any steady load condition, at any outdoor ambient temperature. Unit must be allowed to run 5 minutes or longer so that the condenser fan staging is stabilized at normal operating discharge pressure. For best results charge with 2 or more condenser fans operating per refrigerant circuit.

In case moisture is noticed in the system, through the moisture indicator, the system must be evacuated to eliminate cause of trouble. After the evacuation, the system must be dried reducing it to an almost perfect vacuum. For this purpose, a displacement vacuum pump should be used.

When the system has been opened for extensive repairs, as for an overhaul, it is advisable to use the method of the evacuation as follows:

1. Operate the vacuum pump up to a vacuum of 200 Pa (1,5 mm Hg).
2. Break the vacuum with nitrogen until the atmospheric pressure is reached.
3. Repeat operation 1 and 2.
4. Operate the pump until a final vacuum of 66,5 Pa is reached.

Any moisture and air left in the system will be absorbed by the dry nitrogen used to break the vacuum, and they will be almost completely removed by the three evacuations.

If burnt oil or sludge are found in the refrigerant circuit (caused by the compressor motor burn-out), before the vacuum operation it will be necessary to carefully clean the system using the filter dryer cleanout method; which basically involves the use of special filter dryers incorporating a suitable desiccant in both the liquid and suction lines.

Excessive refrigerant losses can also leak oil from the system. Check the separator oil level during operation and ensure that oil is visible in the top sightglass.

1. If the unit is slightly undercharged the unit will show bubbles in the sightglass. Recharge the unit.
2. If the unit is moderately undercharged the unit will most likely trip on freeze protection. Recharge the unit as described in the charging procedure below.

Procedure to charge a moderately undercharged ALS unit

1. If a unit is low on refrigerant you must first determine the cause before attempting to recharge the unit. Locate and repair any refrigerant leak. Evidence of oil is a good indicator of leakage however, oil may not be visible at all leaks. Liquid leak detector fluids work well to show bubbles at medium size leaks but electronic leak detector may be needed to locate small leaks.
2. Add the charge to the system through the schrader fitting on the tube entering the evaporator between the expansion valve and the evaporator head.
3. The charge can be added at any load condition.

Charging the refrigerant

1. Connect the refrigerant bottle with a filling pipe to the filling valve on the evaporator head. Before firmly tightening the refrigerant bottle valve, open it and force the air out from the filling pipe. Tighten the charging valve connection.
2. When the refrigerant stops to enter the system, start the compressor and complete the refrigerant charge.
3. When the exact quantity of refrigerant has been predetermined, check the liquid sight glass.

If you do not know how much refrigerant has to be added, shut off the bottle valve every 5 minutes and continue to charge the refrigerant until the sight glass is clear and free from bubbles.

Note: Do not discharge the refrigerant into the atmosphere. To recover it, use empty, clean and dry bottles. The liquid refrigerant recovery can be made through the valve provided on the condenser coil subcooler outlet. To facilitate the recovery of refrigerant, put the bottle inside a container full of ice; avoid excessive filling of the bottle (70÷80% max).

Start-up and shut-down

Start-up

- Verify that all shut-off valve are open.
- Prior to starting the unit, open the water circulation pump and regulate the flow to the evaporator in accordance to the setted conditions of the unit.
- Verify that the evaporator inlet and outlet water temperature sensors indicate the same temperature and that the disparity between them and the thermometer does not exceed 0,1°C.
- Turn switch Q0 in position "Local".
- Push the on/off botton on the keypad and wait for the illumination of the same.
- Turn the Q1 botton to position ON. The controller will start the corresponding compressor.

Shut-down

- Turn switch Q1 to position Off. The compressor will carry out its pumpdown cycle and then stop.
- Move all the switches Q2, (Q3 and Q4) to stop the other compressors.
- Turn the Local switch on the off position.
- Push the On/Off switch situated on the keypad to de-energize the same.
- Open the main circuit breaker Q12 to stop the auxiliary circuit.
- Open breaker switch Q10 to remove tension to the unit.

In warranty return material procedure

Material may not be returned except by permission of McQuayService department. A "Return Goods" tag will be included with the returned material. This tag will all informations required to expedite handling at our factory. Return of the parts does not constitute an order for replacement. Therefore, a purchase order must be entered through our nearest Sales Representative. The order should include part name, part number, model number and serial number of the unit involved. Following our per sonal inspection of the returned part, if it is determined that the failure is due to faulty material or workmanship, credit will be issued on the customer's purchase order. All parts shall be returned to McQuay factory, transportation charges prepaid.

Service & replacement parts

Always quote the model number, confirmation number and the machine's serial number stamped on the plaque attached to the machine itself, whenever ordering maintenance service or replacement parts.

If replacement parts are being ordered, state the date the machine was installed and the date the breakdown occurred. For an exact definition of the replacement part requested, make reference to the relative code number or, failing that, attach a description of the part being requested.

Troubleshooting chart

| PROBLEM | POSSIBLE CAUSES | POSSIBLE CORRECTIVE STEPS |
|---|--|--|
| Compressor will not run | <ol style="list-style-type: none"> 1. Main power switch open. 2. Unit system switch open. 3. Circuit switch in pumpdown position. 4. Evaporator flow switch not closed. 5. Circuit breakers open. 6. Fuse blown or circuit breakers tripped. 7. Unit phase voltage monitor not satisfied. 8. Compressor overload tripped. 9. Defective compressor contactor or contactor coil. 10. System shut down by safety devices. 11. No cooling required. 12. Motor electrical trouble. 13. Loose wiring. | <ol style="list-style-type: none"> 1. Close switch. 2. Check unit status on Control Panel. Close switch. 3. Check circuit status on Control Panel. Close switch. 4. Check unit status on Control Panel. Close switch. 5. Close circuit breakers. 6. Check electrical circuits and motor windings for shorts or grounds. Investigate for possible overloading. Check for loose or corroded connections. Reset breakers or replace fuses after fault is corrected. 7. Check unit power wiring to unit for correct phasing. Check voltage. 8. Overloads are manual reset. Reset overload at button on overload. Clear alarm on Microprocessor. 9. Check wiring. Repair or replace contactor. 10. Determine type and cause of shutdown and correct problem before attempting to restart. 11. Check control settings. Wait until unit calls for cooling. 12. See 6, 7, 8 above. 13. Check circuits for voltage at required points. Tighten all power wiring terminals. |
| Compressor Overload Relay Tripped or Circuit Breaker Trip or Fuses Blown | <ol style="list-style-type: none"> 1. Low voltage during high load condition. 2. Loose power wiring. 3. Power line fault causing unbalanced voltage. 4. Defective or grounded wiring in the motor. 5. High discharge pressure. | <ol style="list-style-type: none"> 1. Check supply voltage for excessive voltage drop. 2. Check and tighten all connections. 3. Check supply voltage. 4. Check motor and Replace if defective. 5. See Corrective steps for high discharge pressure. |
| Compressor noisy or vibrating | <ol style="list-style-type: none"> 1. Compressor internal problem 2. Oil injection not adequate. | <ol style="list-style-type: none"> 1. Contact McQuay 2. Contact McQuay. |
| Compressor will not load or unload | <ol style="list-style-type: none"> 1. Defective capacity control. 2. Unloader mechanism defective. 3. Control solenoids defective. | <ol style="list-style-type: none"> 1. See capacity control section. 2. Replace. 3. Replace. |

Troubleshooting chart

| PROBLEM | POSSIBLE CAUSES | POSSIBLE CORRECTIVE STEPS |
|--------------------------------|---|---|
| High discharge pressure | <ol style="list-style-type: none"> 1. Discharge shutoff valve partially closed. 2. Noncondensables in the system. 3. Fans not running. 4. Fan control out of adjustment. 5. System overcharged with refrigerant. 6. Dirty condenser coil. 7. Air recirculation from outlet into unit coils. 8. Air restriction into unit. | <ol style="list-style-type: none"> 1. Open shutoff valve. 2. Purge the noncondensables from the condenser coil after shutdown. 3. Check fan fuses and electrical circuits. 4. Check that unit setup in Microprocessor matches the unit model number. Check Microprocessor condenser pressure sensor for proper operation. 5. Check for excessive subcooling. Remove the excess charge. 6. Clean the condenser coil. 7. Remove the cause of recirculation. 8. Remove obstructions near unit. |
| Low discharge pressure | <ol style="list-style-type: none"> 1. Wind effect at low ambients. 2. Condenser fan control not correct. 3. Low suction pressure. 4. Compressor operating unloaded. | <ol style="list-style-type: none"> 1. Protect unit against excessive wind into vertical coils. 2. Check that unit setup in Microprocessor matches the unit model number. 3. See Corrective Steps for low suction pressure. 4. See Corrective Steps for failure to load. |
| Low suction pressure | <ol style="list-style-type: none"> 1. Inadequate refrigerant charge quantity. 2. Evaporator dirty. 3. Clogged liquid line filter-drier. 4. Expansion valve malfunctioning. 5. Insufficient water flow to evaporator. 6. Water temperature leaving evaporator is too low. 7. Evaporator head ring gasket slippage. | <ol style="list-style-type: none"> 1. Check liquid line sightglass. Check unit for leaks. 2. Clean chemically. 3. Replace 4. Check expansion valve superheat and valve opening position. Replace valve only if certain valve is not working. 5. Check water pressure drop across the evaporator and Adjust gpm. 6. Adjust water temperature to higher value. 7. Low suction pressure and low superheat both present may indicate an internal problem. Consult factory. |
| High suction pressure | <ol style="list-style-type: none"> 1. Excessive load - high water temperature. 2. Compressor unloaders open. 3. Superheat is too low. | <ol style="list-style-type: none"> 1. Reduce load or add additional equipment. 2. See Corrective Steps below for failure of compressor to load. 3. Check superheat on Microprocessor display. Check suction line sensor installation and sensor. |

We reserve the right to make changes in design and construction at any time without notice, thus the cover picture is not binding.



McQuay Italia S.P.A.

S.S. Nettunense, km 12+300 – 00040 Cecchina (Roma) Italia – Tel. (06) 937311 – Fax (06) 9374014