

## Air cooled water chillers

### Air cooled motocondensing unit

ALZ “B” 011.1 ÷ 038.2

ALP “B” 011.1 ÷ 038.2

Cooling capacity from 40 to 145 kW

50Hz – Refrigerant: HFC 407C

Scroll Compressors

**HFC 407C**

ECOLOGICAL REFRIGERANT



McQuay is participating in the Eurovent Certification Programme. Product are as listed in the Eurovent Directory of Certified Products and on the web site [www.eurovent-certification.com](http://www.eurovent-certification.com)

**McQuay**<sup>®</sup>  
Air Conditioning



# New McQuay Air cooled chillers and motocondensing unit ALZ/ALP

McQuay International introduces their newest air cooled chillers ALZ equipped with scroll compressors and electronic control system. McQuay have once again succeeded in developing a high quality product with extraordinary performance which is able to satisfy HVAC applications.

McQuay units are completely factory assembled, piped, wired and charged with refrigerant and shipped ready for the installation.

Each unit consists of scroll compressors, condenser coils with independent subcooler circuits, multiple propeller type direct drive condenser fans with independent fan motors, heavy-gauge weatherproof casing and weatherproof electrical control centre containing all necessary and operating controls and motor starting equipment.

ALZ / ALP units are high thermodynamic engineering products, studied with high accuracy in balancing compressors, condensers and evaporators in order to offer high performances and wide safety margins. The choice of the materials and the equipments adopted for the products has been made without any compromises, taking care of quality and long life purposes. The products meet ISO 9001:2000 requirements, an assurance, beyond any doubts, of the high producing standards followed by McQuay.

## Highly flexible design

The ALZ / ALP units are available in 10 sizes covering a range from 40 to 145 kW nominal cooling capacity. Availability of many accessories, and the applications of high tech control and safety devices, give to these products high flexibility for their installation in commercial, residential and industrial environments.

## Refrigerant

As the HCFC phase out will occur more quickly than currently legislated, the designers, owners and operators should only evaluate equipment using chlorine free refrigerants. ALZ / ALP units are supplied with ecological refrigerant HFC 407C. Studied and used by McQuay for several years, it offers the same garancies of performance, costs and reliability of refrigerant HCFC 22.

## Lowest sound pressure level

Use of scroll compressors, fixed at the unit base by means of rubber type antivibration mounts, along with construction expedients useful to suppress any noise or vibration transmission and the availability of a low-noise version makes the new McQuay ALZ/ALP line absolutely suitable for installation where silence is a fundamental requirement.

## Low installation costs

The complete assembly of the units and fuction testing at the factory reduces the cost of installation on site. A rigid steel base distributes the weight of the unit to the support points and allows simple installation by an easy access to the lifting points. The units are designed with a single point 400/3/50 + NEUTRAL. The ALZ units can also include a pumping set consisting of one or more water circulation pumps and buffer tank (optional).

## Low maintenance costs

The microprocessor safety and control system allows the trouble shooting of any type of functional anomaly, enabling simpler, safer and timely intervention by the unit maintenance personnel. The oil heater on each compressor and a complete set of controls and safety devices protect the unit from abnormal operating conditions. The design of the ALZ unit, with two independent refrigerant circuits, increases the redudancy of the unit and allows maintenance while the other circuit is still running.

## Certifications

All the ALZ/ALP units are CE marked (89/392). McQuay Italia obtained ISO 9001:2000.

## Factory testing

Each unit is pressure tested, vacuum tested, evacuated and charged with refrigerant requested. It is then tested at the factory's test bench under the design conditions specified by the customer. Upon request, a second series of tests can be carried out witnessed by the customer. Before shipment, each unit is re-checked for pressure and refrigerant charge control.

# General characteristics

## Cabinet and structure

The cabinet is made of galvanized steel sheet and painted to provide a high resistance to corrosion. The unit base frame has holes to lift the unit with ropes for an easy installation. The weight is uniformly distributed along the profiles of the base and this facilitates the arrangement of the unit's bases and the support structures. The electrical and control equipment is located inside a panel which can be accessed by key locked doors complete with door interlocking on the power cabinet.

The unit cabinet can be sound insulated (as an option) in order to reduce the noise of the compressors.

## Scroll compressors

The scroll compressors achieve a high volumetric efficiency, due to constant contact with the sides of the scroll spirals and the total absence of discharge and suction valves. This compressor is not only extremely reliable thanks to the reduced number of moving parts, but has an exceptionally low noise level because of the absence of suction and discharge valves and hence of the reduced pulsations of the discharge gas. The reduction in moving parts means a very low level of vibration. Each compressor is equipped with a check valve on the discharge to maintain the pump-down condition and hence avoid the migration of the refrigerating gas from the condenser to the evaporator.

## Evaporator (only ALZ units)

The evaporator is a compact, efficient, dual circuit plate to plate type heat exchanger consisting of stainless steel brazed plates.

The evaporator is wrapped with closed cell heat insulation and equipped with an heater for protection against freezing down to  $-29^{\circ}\text{C}$ .

## Condenser coils

ALZ condenser coils are constructed with internally enhanced seamless copper tubes arranged in a staggered row pattern and mechanically expanded into McQuay lanced and rippled aluminium condenser fins with full fin collars.

## Condenser coil fans

The condenser fans are of the axial helical type with wing-profile blades to achieve a better performance. The direct coupling with the electrical motor eliminates any problems as regards the application of transmission devices and reduces the vibrations caused by the functioning. The motors are supplied as standard with IP54 protection and are of the mono-phase external rotor type; they are protected against overload and short circuits by circuit breakers located inside the electrical control panel.

## Electrical control panel and control devices

The electrical components for both the power and the control are split into two sections on the main panel. The panel is manufactured to ensure protection in all weather conditions (IP 54). The power panel is fitted with a door interlocked mains isolator to prevent access. The electrical control panel complies with IEC204-1 safety norms. The power section includes: compressors contactors and fuses, fans magneto-thermal. Additional space is provided for the installation of the various optional accessories provided to enhance the capabilities of the ALZ units.

The control section includes the microprocessor regulator of the water temperature (ALZ) which carries out the following functions:

- access password to prevent unauthorised access
- water temperature control
- regulation of temperature set points
- start-up sequence delay device
- compressor on-off control
- fan on-off control
- antifreeze control
- antifreeze heater functioning
- general alarm
- differential pressure switch or pump failure alarm

The multifunctional microprocessor control device has contacts for remote on/off control and remote signal of general failure.

On request, remote programming infrared-control and remote PC board are available as option.

## Refrigerant circuit

The ALZ units are equipped with a complete refrigerant charge. The ALP units are equipped only by a holding charge to keep the circuit in pressure and to avoid moisture infiltration.

The ALZ circuits consist of insulated copper pipes on the suction line and is complete with filter driers, moisture indicators, liquid sight glass, thermostatic expansion valves and drain valves.

ALP motocondensing units are not equipped by liquid and suction lines. Customer will have to provide: antivibration isolators, filter driers, solenoid valves, moisture indicators, thermostatic expansion valves.

All the refrigerant pipes connections are welded to ensure a total absence of refrigerant leakages.

## Standard Accessories (furnished on basic unit)

**Water pressure differential switch** – Safety device against missing evaporator water flow.

**Fans magneto-thermal overload relays** – Safety devices against fans motor overload.

## Options (on request)

**100% total heat recovery (R)** (only for ALZ units) - Produced with plate heat exchangers to produce hot water up to +50°C. The heat exchangers are mounted on the refrigerant circuits parallel to the condenser coils to remove all the heat rejection.

**25% Partial heat recovery** (only for ALZ units) - Produced with plate heat exchangers installed between the compressor discharge and the condenser coil. These allow hot water to be produced up to a maximum temperature of +55°C.

**Compressor thermal overload relays** – Safety devices against compressor motor overload.

**Condenser power factor correction** - Installed on the electrical control panel to ensure the conformance to the local rules.

**Fan speed regulator** - This device allows the continuous variation of the fan speed, modifying the air flow according to the external temperature conditions down to -10°C.

**Condenser coil guards** - Metal protection guards fixed on all the external surface of the condenser coils.

**Cu-Cu condensing coils** - To give better protection against corrosion by aggressive environments.

**Alucoat condensing coils** - Fins are protected by a special epoxy paint with a high resistance to corrosion.

**Water circulation pump + Inertial tank (factory unit mounted)** - Pump unit, assembled and wired, consists of a water circulation pump (max. working pressure 6 bar) complete with safety valve and 8 litre expansion tank. The pump motor is protected by a circuit breaker. A cooled water buffer tank gives hydraulic plant inertia and reduce excessive compressors starts and stops. The tank has a 180 l capacity and is complete with: automatic filling module, manual vent valve, drain tap and 150 W antifreeze heater. The tank is heat insulated with 20-mm thick PU and wrapped with PVC.

**Two water circulation pumps + Inertial tank (factory unit mounted)** - Pump unit, assembled and wired, consisting of two water circulation pumps (max. working pressure 6 bars) complete with shut-off valve, check valves, safety valve and 8 litre expansion tank. The pump motors are protected by circuit breakers and controlled by a two-position switch. A cooled water buffer tank gives hydraulic plant inertia and reduce excessive compressors starts and stops. The tank has a 180 l capacity and is complete with: automatic filling module, manual vent valve, drain tap and 150 W antifreeze heater. The tank is heat insulated with 20-mm thick PU and wrapped with PVC.

**NOTE:** one and two pumps options always include inertial tank.

**Microprocessor program remote infrared-control** – Infrared-control to remote program data.

**Wooden box packing** - Self-supporting wooden box internally insulated and suitable for shipment by sea.

**Open Cage packing** - Protection with polythene and wooden cage for transport and protection before the installation.

**Rubber type antivibration mounts** - Supplied separately, these will be positioned under the base of the unit during installation. Ideal to reduce the vibrations when the unit is floor mounted.

**Spring type antivibration mounts** - Supplied separately, these will be positioned under the base of the unit during installation. Ideal for dampening vibrations for installation on roofs and metallic structures.

**Low noise version** – For this version internal side of the steel cabinet is covered by soundproof material to allow compressor sound insulation. Also fan speed control is supplied.

**Table 1 – Operating limits**

ALZ	Entering evaporator water temperature		Leaving evap. water temp. (without glycol)		Evaporator water ΔT		Ambient temperature	
	Min (°C)	Max (°C)	Min (°C)	Max (°C)	Min (°C)	Max (°C)	Min (°C)(*)	Max (°C)
011.1	8	20	4	15	4	8	15	42
013.1	8	20	4	15	4	8	15	42
017.1	8	20	4	15	4	8	14	42
020.1	8	20	4	15	4	8	12	40
022.2	8	20	4	15	4	8	15	42
025.2	8	20	4	15	4	8	13	40
029.2	8	15	4	10	4	8	12	40
033.2	8	15	4	10	4	8	10	40
036.2	8	20	4	15	4	8	15	42
038.2	8	20	4	15	4	8	15	40

(\*) for ambient temperature down to -10°C low ambient kit is required (fan speed control)

**Table 2 – Altitude correction factor**

Elevation above sea level (m)	0	300	600	900	1200	1500	1800
Barometric pressure (mbar)	1013	977	942	908	875	843	812
Cooling capacity correction factor	1,000	0,991	0,981	0,972	0,962	0,953	0,943

**Table 3 – Ethylene glycol and low ambient temperature correction factors**

Air ambient temperature °C	-3	-8	-15	-23	-35
% of ethylene glycol correction factor	10	20	30	40	50
Cooling capacity correction factor	0,986	0,980	0,973	0,966	0,960
Flow rate correction factor	1,023	1,054	1,092	1,140	1,200
Water pressure drops correction factor	1,061	1,114	1,090	1,244	1,310

**Table 4 - Low temperature operation performance factors**

Ethylene glycol/water leaving temperature °C	2	0	-2	-6	-8
Cooling capacity correction factor	0,842	0,783	0,725	0,615	0,562
Power input compressors correction factor	0,950	0,934	0,918	0,870	0,845
Min % of ethylene glycol	10	20	20	30	30
Max air ambient temperature °C	40	40	38	34	32

**Table 5 - Fouling factor**

Fouling factor m <sub>2</sub> °C / kW	Cooling capacity correction factor
0,044	1,000
0,132	0,986
0,308	0,939

### Water content in cooling circuits

The cooled water distribution circuits should have a minimum water content to avoid excessive compressors start and stop.

In fact, each time the compressor starts up, an excessive quantity of oil goes from the compressor's sump and simultaneously there is a rise in the temperature of the compressor motor's stator due to the inrush current during the start-up. To prevent damage to the compressors, McQuay has envisaged the application of a device to limit frequent stops and restarts.

During the span of one hour there will be no more than 6 starts of the compressor. The plant side should therefore ensure that the overall water content allows a more constant functioning of the unit and consequently greater

environmental comfort. The minimum installation water content envisaged should be calculated with a certain approximation using this formula:

$$(1) \quad Q = 35,83 \frac{P \text{ (kW)}}{\Delta T(^{\circ}\text{C})} \times \frac{1}{N}$$

where:

Q =minimum plant content (litres)

P =nominal plant cooling capacity

$\Delta T$  =difference between evaporator inlet water temperature and evaporator outlet water temperature ( $^{\circ}\text{C}$ )

N =compressors number.

For a more accurate determination of the quantity of water, it is advisable to contact the designer of the plant.

## Installation notes

### Handling

All moving and handling may damage the unit if some conditions are not scrupulously observed. The units should be lifted with a crane using long ropes anchored to the holes on the frame of the unit's base and by using the upper spacer bars to prevent the ropes from damaging the condenser coils.

### Location

The ALZ/ALP units are produced for outside installation on roofs, floors or below ground level on condition that the area is free from obstacles for the passage of the condensation air. The unit should be positioned on solid foundations and perfectly level; in the case of installation on roofs or floors, it may be advisable to arrange the use of suitable weight distribution beams. When the units are installed on the ground, a concrete base at least 250 mm wider and longer than the unit's footprint should be laid. Furthermore, this base should be sufficiently robust to withstand the unit weight mentioned in the technical data table. When the units are positioned in areas which are easily accessible by persons or animals, it is advisable to fit guards (option) to protect the condenser and the compressors.

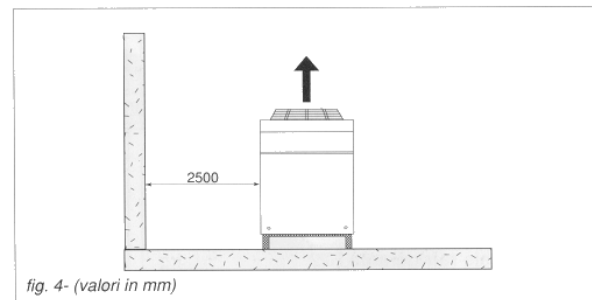
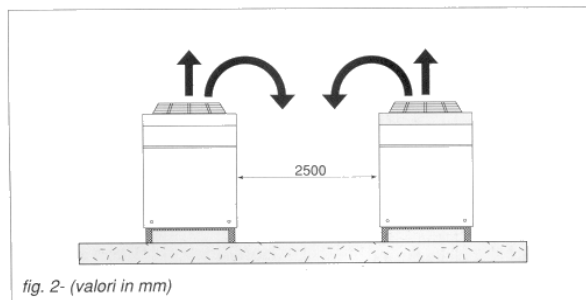
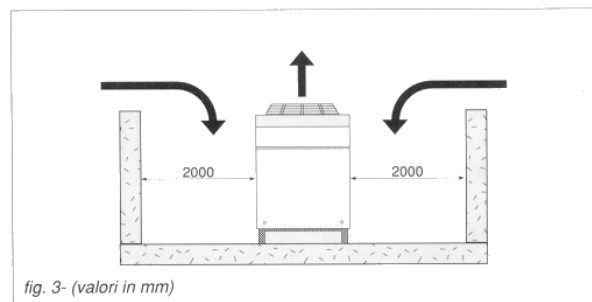
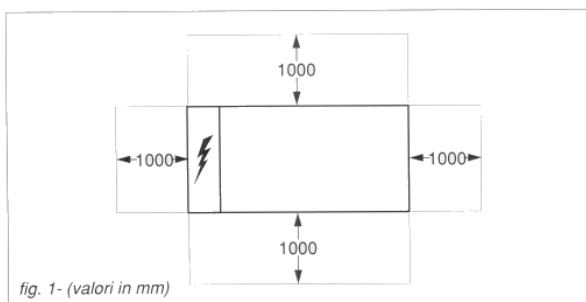

## Space requirements

The ALZ/ALP units are air-cooled, hence it is important to observe the minimum distances which guarantee the best ventilation of the condenser coils. Limitations of space reducing the air flow could cause significant reductions in cooling capacity, and increase in electricity consumption. The fans do not allow the use of ducts which have high flow resistance, hence it should be ensured that the output air cannot recycle itself inside the condenser coils. The units should be positioned such that there is sufficient distance between the coils and any obstacles to improve ventilation and also to facilitate inspection (fig.1).

When two or more units are positioned side by side it is recommended that the condenser coils are at least 2500mm distance from one another (fig. 2). Smaller distances could cause the recirculation of hot air. If the units are positioned in places surrounded by walls or obstacles of the same height as the units, the units should be at least 2000mm from said obstacles (fig. 3). In the event the obstacles are higher than the units, the units should be at least 2500mm from the obstacle (fig. 4). For other installation solutions, consult McQuay technicians.

## Acoustic protection

The low noise levels of the ALZ/ALP units means that they meet most of the most restrictive regulations. When the noise level must meet special requirements it will be necessary to pay the maximum attention to ensure the perfect insulation of the unit from the support base by applying appropriate vibration-dampening devices, applying vibration-dampening mounts on the water pipes and on the electrical connections (by the customer).

## Nomenclature

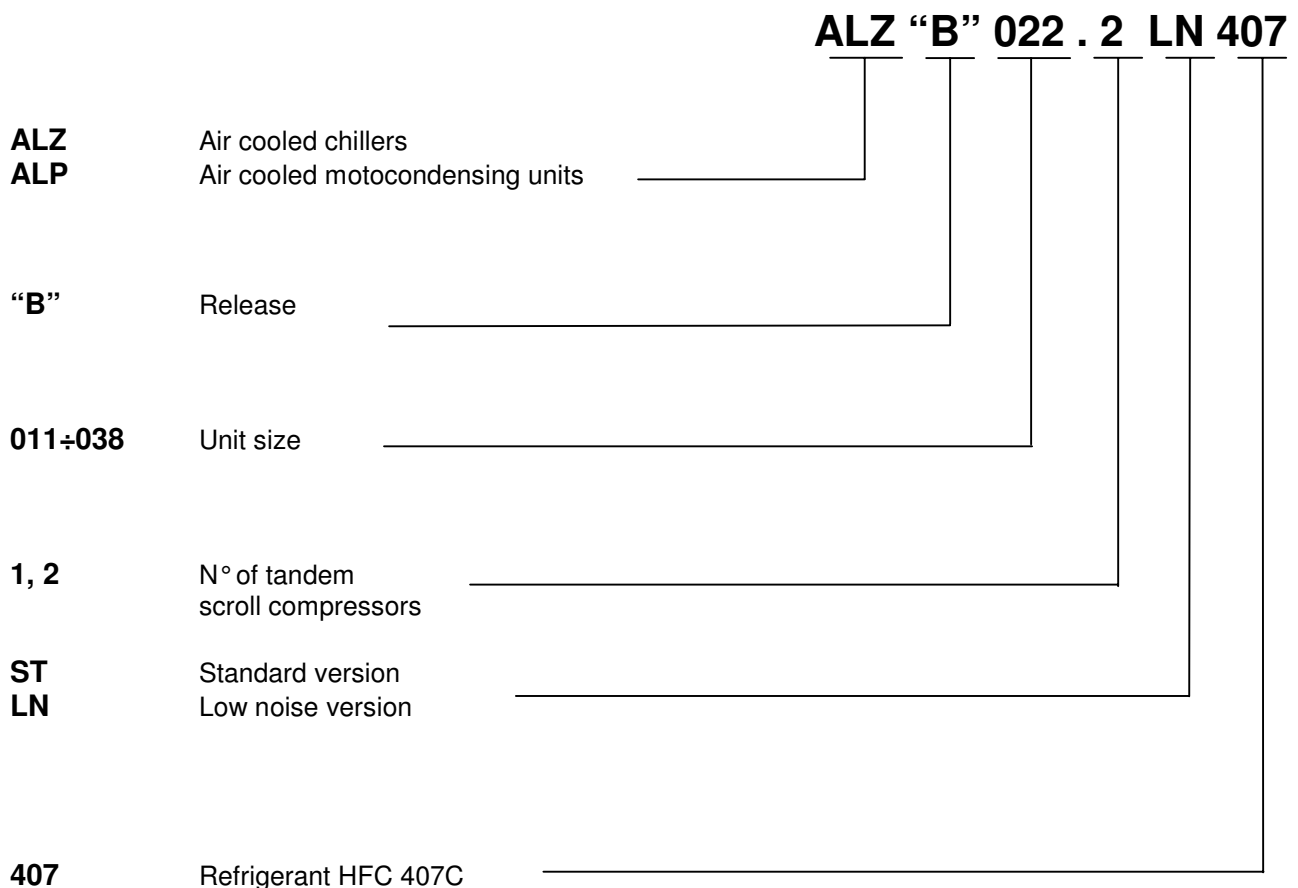



## Physical data ALZ “B” HFC 407C units

ALZ “B” unit size		011.1	013.1	017.1	020.1	022.2
Cooling capacity (1)	kW	42,7	49,7	60,6	71,8	84,3
Power input (1)	kW	15,2	18,6	24,1	30,0	32,1
Cooling cap. heat recovery cond.(2)	kW	43,5	52,7	62,5	79,7	87,5
Heating capacity (2)	kW	56,2	67,0	82,2	103,7	113,5
Power input heat recovery cond. (2)	kW	14,5	16,3	22,2	27,2	29,6
Desuperheaters heating capacity (3)	kW	10,4	12,2	14,8	17,7	21,0
Desuperheaters pressure drops (3)	kPa	14	18	15	20	18

### Scroll compressors

No. of compressors / No of circuits		1 Tandem/1	1 Tandem/1	1 Tandem/1	1 Tandem/1	2 Tandem/2
Oil charge	l	6,5	6,5	10,4	13,2	6,5+6,5
No. of reduction steps		2	2	2	2	2
Refrigerant charge	kg	12	12	14	16	22

### Plate heat exchange

Water volume	l	2,6	2,9	3,6	4,4	5,2
Max. water pressure	bar	30	30	30	30	30
Water connections		Male 2” GAS				

### Condenser fans

No. of fans / Diameter	mm	2 / 630	2 / 630	2 / 630	2 / 630	3 / 630
Motor power / RPM	Kw / rpm	0,6 / 880	0,6 / 880	0,6 / 880	0,6 / 880	0,6 / 880

### Dimensions and weights

Unit length	mm	2780	2780	2780	2780	3530
Unit width	mm	1200	1200	1200	1200	1200
Unit height	mm	1400	1400	1400	1400	1400
Standard unit shipping weight	kg	663	666	721	774	1059
Standard unit operating weight	kg	666	670	726	780	1066
Std unit with 2 pumps kit ship. weight	kg	763	766	821	874	1159
Std unit with 2 pumps kit oper. weight	kg	916	920	976	1030	1316

ALZ “B” unit size		025.2	029.2	033.2	036.2	038.2
Cooling capacity (1)	kW	95,3	107,5	117,7	133,7	144,9
Power input (1)	kW	39,6	45,2	52,4	54,3	60,1
Cooling cap. heat recovery cond.(2)	kW	100,4	116,1	123,9	143,9	151,3
Heating capacity (2)	kW	132,4	152,4	166,3	189,6	200,9
Power input heat recovery cond. (2)	kW	35,8	41,5	47,9	51,2	55,4
Desuperheaters heating capacity (3)	kW	23,4	26,6	28,4	32,7	35,7
Desuperheaters pressure drops (3)	kPa	20	19	24	24	25

### Scroll compressors

No. of compressors / No of circuits		2 Tandem/2	2 Tandem/2	2 Tandem/2	2 Tandem/2	2 Tandem/2
Oil charge	l	6,5+6,5	6,5+10,4	10,4+10,4	10,4+13,2	13,2+13,2
No. of reduction steps		2	2	2	2	2
Refrigerant charge	kg	22	29	30	47	48

### Plate heat exchange

Water volume	l	5,8	6,8	7,6	9,7	9,7
Max. water pressure	bar	30	30	30	30	30
Water connections		Male 2” GAS				

### Condenser fans

No. of fans / Diameter	mm	3 / 630	3 / 630	3 / 630	4 / 630	4 / 630
Motor power / RPM	Kw / rpm	0,6 / 880	0,6 / 880	0,6 / 880	0,6 / 880	0,6 / 880

### Dimensions and weights

Unit length	mm	3530	3530	3530	4280	4280
Unit width	mm	1200	1200	1200	1200	1200
Unit height	mm	1400	1400	1400	1400	1400
Standard unit shipping weight	kg	1062	1135	1155	1353	1378
Standard unit operating weight	kg	1070	1146	1166	1368	1392
Std unit with 2 pumps kit ship. weight	kg	1162	1235	1255	1453	1478
Std unit with 2 pumps kit oper. weight	kg	1320	1396	1416	1618	1642

Notes: (1) Nominal cooling capacity and power input are based on: 12/7 °C entering/leaving evaporator water temperature; 35 °C ambient temperature.

(2) Nominal cooling capacity, power input and heating capacity are based on: 12/7 °C entering/leaving evaporator water temperature; 45 °C leaving HR water temperature.

(3) Desuperheaters heating capacity and pressure drops are based on: 12/7 °C entering/leaving evaporator water temperature; 40/45 °C entering/leaving desuperheater water temperature; 35 °C ambient temperature.

## Electrical data ALZ/ALP “B”

ALZ “B” unit size	011.1	013.1	017.1	020.1	022.2	025.2	029.2	033.2	036.2	038.2	
Standard voltage (1)	400 V - 3f - 50 Hz + NEUTRAL										
Nominal unit current (2)	A	32,3	37,8	45,4	54,8	64,1	75,9	83,9	93,5	99,4	109,8
Max compressor current (3)	A	29,3	35,4	44,4	54,6	61,0	74,4	83,8	95,2	98,0	109,6
Fans current	A	5,4	5,4	5,4	5,4	8,1	8,1	8,1	8,1	10,8	10,8
Max unit current (3)	A	34,7	40,8	49,8	60,0	69,1	82,5	91,9	103,3	108,8	120,4
Max unit inrush current (4)	A	151,6	154,3	203,1	207,8	186,2	195,0	246,0	253,2	260,4	268,2
Max unit current for wires sizing (5)	A	45,4	63,4	65,4	75,4	88,1	124,1	126,1	128,1	140,8	150,8

- Notes:** (1) Allowed voltage tolerance  $\pm 10\%$ . Voltage unbalance between phases must be within  $\pm 3\%$ .  
(2) Nominal current are based on: 12/7 °C entering/leaving evaporator water temperature and 35°C ambient temp.  
(3) Maximum current are based on: 14/9 °C entering/leaving evaporator water temperature and 40°C ambient temp.  
(4) Inrush current of biggest compressor + nominal absorbed current of the other compressors.  
(5) Compressor FLA + fans current.

## Sound pressure level ALZ/ALP “B” – ST

ALZ / ALP unit size	Sound pressure level at 1 m from the unit in free field ( rif. $2 \times 10^{-5}$ )								
	63 Hz	125 Hz	250 Hz	500 Hz	1000 Hz	2000 Hz	4000 Hz	8000 Hz	dBA
011.1	68,0	68,0	65,0	64,5	64,0	58,5	51,0	43,5	67,5
013.1	68,0	68,0	65,0	64,5	64,0	58,5	51,0	43,5	67,5
017.1	68,0	68,0	65,0	64,5	64,0	58,5	51,0	43,5	67,5
020.1	68,0	68,0	65,0	64,5	64,0	58,5	51,0	43,5	67,5
022.2	70,0	69,5	66,5	66,0	65,5	60,0	52,5	45,0	69,0
025.2	70,0	69,5	66,5	66,0	65,5	60,0	52,5	45,0	69,0
029.2	70,0	69,5	66,5	66,0	65,5	60,0	52,5	45,0	69,0
033.2	70,0	69,5	66,5	66,0	65,5	60,0	52,5	45,0	69,0
036.2	71,0	70,5	67,5	67,0	66,5	61,0	53,5	46,0	70,0
038.2	71,0	70,5	67,5	67,0	66,5	61,0	53,5	46,0	70,0

## Sound pressure level ALZ “B” / ALP “B” – LN

ALZ / ALP unit size	Sound pressure level at 1 m from the unit in free field ( rif. $2 \times 10^{-5}$ )								
	63 Hz	125 Hz	250 Hz	500 Hz	1000 Hz	2000 Hz	4000 Hz	8000 Hz	dBA
011.1	67,0	66,0	62,0	60,5	60,0	54,0	47,0	38,0	63,5
013.1	67,0	66,0	62,0	60,5	60,0	54,0	47,0	38,0	63,5
017.1	67,0	66,0	62,0	60,5	60,0	54,0	47,0	38,0	63,5
020.1	67,0	66,0	62,0	60,5	60,0	54,0	47,0	38,0	63,5
022.2	68,5	67,5	63,5	62,0	61,5	55,5	48,5	39,5	65,0
025.2	68,5	67,5	63,5	62,0	61,5	55,5	48,5	39,5	65,0
029.2	68,5	67,5	63,5	62,0	61,5	55,5	48,5	39,5	65,0
033.2	68,5	67,5	63,5	62,0	61,5	55,5	48,5	39,5	65,0
036.2	69,5	68,5	64,5	63,0	62,5	56,5	49,5	40,5	66,0
038.2	69,5	68,5	64,5	63,0	62,5	56,5	49,5	40,5	66,0

**Note:** Average sound pressure level rated in accordance to ISO 3744, free field conditions.

**Table 6 – Sound pressure level correction factor for different distances**

Distance (m)		1	5	10	15	20	25
ALZ/ALP 011.1÷020.1	dBA	0	-9,0	-14,1	-17,3	-19,7	-21,5
ALZ/ALP 022.2÷033.2	dBA	0	-8,7	-13,8	-16,9	-19,3	-21,1
ALZ/ALP 036.2÷038.2	dBA	0	-8,7	-13,7	-16,9	-19,2	-21,0

## Standard ratings ALZ “B” 011.1÷022.2 HFC 407C

Unit size HFC 407C	Evaporator leaving temp. (°C)	AMBIENT TEMPERATURE - °C									
		25		30		32		35		40	
		Cooling capacity (kW)	Power input (kW)	Cooling capacity (kW)	Power input (kW)	Cooling capacity (kW)	Power input (kW)	Cooling capacity (kW)	Power input (kW)	Cooling capacity (kW)	Power input (kW)
011.1	4	43,2	11,9	41,2	13,3	40,4	13,9	39,1	14,9	36,8	16,5
	5	44,5	12,0	42,4	13,4	41,6	14,0	40,4	15,0	38,0	16,6
	6	45,8	12,2	43,8	13,5	42,9	14,1	41,5	15,1	39,1	16,8
	7	47,1	12,3	45,0	13,6	44,1	14,2	42,7	15,2	40,4	16,9
	8	48,5	12,4	46,4	13,7	45,4	14,3	44,0	15,3	41,5	17,1
	9	49,9	12,4	47,7	13,8	46,8	14,5	45,3	15,4	42,7	17,2
	10	51,3	12,5	49,0	13,9	48,0	14,6	46,6	15,6	44,0	17,3
013.1	4	50,6	14,5	48,1	16,1	47,1	16,9	45,6	18,1	42,8	20,3
	5	52,1	14,6	49,6	16,2	48,5	17,0	46,9	18,2	44,1	20,4
	6	53,6	14,7	51,2	16,5	50,1	17,2	48,3	18,4	45,4	20,6
	7	55,2	14,9	52,7	16,6	51,5	17,3	49,7	18,6	46,7	20,7
	8	56,7	15,0	54,1	16,7	53,0	17,6	51,3	18,8	48,0	21,0
	9	58,3	15,1	55,6	16,9	54,4	17,7	52,7	18,9	49,4	21,1
	10	59,9	15,3	57,1	17,0	55,9	17,9	54,1	19,1	50,9	21,3
017.1	4	62,0	18,9	58,9	20,9	57,6	21,9	55,7	23,3	51,9	26,2
	5	63,8	19,1	60,7	21,2	59,3	22,1	57,2	23,6	53,5	26,5
	6	65,6	19,2	62,4	21,4	61,0	22,4	58,9	23,9	55,1	26,6
	7	67,5	19,4	64,2	21,6	62,8	22,6	60,6	24,1	56,7	26,9
	8	69,4	19,5	66,0	21,8	64,6	22,8	62,3	24,3	58,3	27,2
	9	71,3	19,7	67,8	22,1	66,3	23,1	64,0	24,6	59,9	27,4
	10	73,2	19,9	69,6	22,4	68,1	23,3	65,8	24,9	61,6	27,7
020.1	4	73,6	23,4	70,0	26,1	68,3	27,3	65,9	29,1	61,6	32,4
	5	75,7	23,7	72,0	26,4	70,3	27,5	67,8	29,4	63,4	32,7
	6	77,8	23,9	73,9	26,6	72,3	27,9	69,7	29,7	65,2	33,0
	7	79,9	24,2	76,0	26,9	74,3	28,2	71,8	30,0	67,0	33,3
	8	82,2	24,5	78,0	27,2	76,2	28,5	73,7	30,3	68,9	33,7
	9	84,4	24,8	80,1	27,5	78,3	28,7	75,6	30,6	70,8	34,0
	10	86,6	25,1	82,3	27,9	80,4	29,1	77,6	30,9	72,6	34,3
022.2	4	85,8	25,1	81,7	28,0	79,9	29,3	77,2	31,3	72,3	34,9
	5	88,4	25,4	84,1	28,3	82,3	29,6	79,6	31,6	74,7	35,2
	6	90,9	25,7	86,6	28,5	84,7	29,8	81,9	31,8	76,9	35,5
	7	93,7	25,9	89,1	28,9	87,2	30,2	84,3	32,1	79,2	35,8
	8	96,3	26,1	91,8	29,1	89,8	30,4	86,8	32,3	81,5	36,2
	9	99,0	26,3	94,3	29,4	92,3	30,7	89,3	32,7	83,8	36,4
	10	101,7	26,6	96,9	29,6	94,9	30,9	91,8	33,0	86,2	36,7

- Notes:** (1) Rating based on: evaporator fouling factor of 0,044 m<sup>2</sup> °C/ kW, evaporator temperature drop of 5°C and sea level altitude.  
(2) Interpolation is allowed, extrapolation is not permitted. Please contact McQuay for performance outside the standard ratings.  
(3) The power input values are referred to compressor only.

## Standard ratings ALZ “B” 025.2÷038.2 HFC 407C

Unit size HFC 407C	Evaporator leaving temp. (°C)	AMBIENT TEMPERATURE - °C									
		25		30		32		35		40	
		Cooling capacity (kW)	Power input (kW)	Cooling capacity (kW)	Power input (kW)	Cooling capacity (kW)	Power input (kW)	Cooling capacity (kW)	Power input (kW)	Cooling capacity (kW)	Power input (kW)
025.2	4	97,8	30,7	92,9	34,3	90,7	35,9	87,5	38,4	81,6	43,0
	5	100,7	31,0	95,6	34,6	93,4	36,3	90,1	38,8	84,1	43,5
	6	103,7	31,4	98,4	35,0	96,1	36,6	92,6	39,1	86,6	43,8
	7	106,6	31,7	101,1	35,3	98,8	37,0	95,3	39,6	89,0	44,1
	8	109,5	32,0	104,0	35,7	101,5	37,4	97,9	39,9	91,6	44,6
	9	112,5	32,3	106,8	36,1	104,4	37,7	100,7	40,3	94,1	45,0
	10	115,5	32,7	109,7	36,5	107,2	38,1	103,5	40,6	96,7	45,3
029.2	4	110,7	35,1	104,9	39,2	102,4	41,0	98,7	43,9	91,9	48,9
	5	113,9	35,6	108,0	39,6	105,4	41,5	101,5	44,2	94,6	49,5
	6	117,2	35,9	111,1	40,1	108,5	41,9	104,6	44,7	97,3	50,0
	7	120,5	36,3	114,2	40,5	111,6	42,4	107,5	45,2	100,2	50,5
	8	123,9	36,8	117,5	40,9	114,7	42,8	110,6	45,6	103,0	51,0
	9	127,3	37,2	120,6	41,4	117,8	43,3	113,6	46,2	105,8	51,4
	10	130,6	37,5	123,9	41,8	121,0	43,8	116,7	46,6	108,8	52,0
033.2	4	121,8	40,7	115,3	45,3	112,5	47,5	108,1	50,7	100,3	56,6
	5	125,4	41,1	118,6	45,9	115,7	48,0	111,3	51,3	103,2	57,3
	6	128,8	41,7	121,9	46,5	118,9	48,6	114,5	51,8	106,2	57,9
	7	132,3	42,2	125,3	47,0	122,2	49,2	117,7	52,4	109,1	58,6
	8	136,0	42,8	128,7	47,6	125,5	49,7	120,8	53,0	112,2	59,1
	9	139,6	43,3	132,1	48,1	128,9	50,3	124,0	53,6	115,2	59,8
	10	143,2	43,9	135,5	48,7	132,2	50,9	127,2	54,3	118,2	60,4
036.2	4	137,2	42,4	130,3	47,3	127,2	49,3	122,7	52,6	114,5	58,6
	5	141,2	42,9	134,1	47,7	131,0	49,9	126,3	53,2	117,9	59,3
	6	145,4	43,3	138,0	48,2	134,8	50,4	130,0	53,7	121,4	59,8
	7	149,5	43,9	141,9	48,8	138,6	51,0	133,7	54,3	124,9	60,5
	8	153,7	44,3	146,0	49,3	142,6	51,5	137,5	54,9	128,4	61,2
	9	157,9	44,9	150,0	49,9	146,5	52,1	141,3	55,5	132,0	61,7
	10	162,1	45,4	154,0	50,4	150,5	52,7	145,2	56,1	135,6	62,4
038.2	4	148,8	46,9	141,3	52,2	138,0	54,6	133,1	58,1	124,3	64,8
	5	153,2	47,5	145,4	52,8	142,0	55,1	137,0	58,7	127,9	65,4
	6	157,5	48,0	149,5	53,4	146,1	55,8	140,9	59,4	131,6	66,1
	7	161,9	48,6	153,8	54,0	150,3	56,4	144,9	60,1	135,3	66,8
	8	166,4	49,1	158,0	54,6	154,4	57,0	148,9	60,7	139,1	67,5
	9	170,8	49,8	162,3	55,2	158,6	57,7	153,0	61,4	142,9	68,2
	10	175,4	50,3	166,6	55,9	162,8	58,3	157,1	62,0	146,7	68,9

- Notes:** (1) Rating based on: evaporator fouling factor of 0,044 m<sup>2</sup> °C/ kW, evaporator temperature drop of 5°C and sea level altitude.  
(2) Interpolation is allowed, extrapolation is not permitted. Please contact McQuay for performance outside the standard ratings.  
(3) The power input values are referred to compressor only.

## Total heat recovery ratings ALZ “B” 011.1÷022.2 HFC 407C

Unit size HFC 407C	Evaporator leaving temp. (°C)	LEAVING HEAT RECOVERY CONDENSER WATER TEMPERATURE								
		40			45			50		
		Cooling capacity (kW)	Power input (kW)	Heating capacity (kW)	Cooling capacity (kW)	Power input (kW)	Heating capacity (kW)	Cooling capacity (kW)	Power input (kW)	Heating capacity (kW)
011.1	4	43,7	14,1	56,4	41,1	14,1	53,5	38,4	15,0	51,9
	5	45,0	14,1	57,8	42,3	14,2	54,8	39,6	15,0	53,1
	6	46,4	14,1	59,0	43,1	14,4	55,9	40,7	15,0	54,0
	7	48,9	14,2	61,6	43,5	14,5	56,2	41,9	15,1	55,2
	8	50,3	14,2	63,0	44,3	14,6	57,2	43,9	15,1	57,2
	9	52,5	14,3	65,3	45,5	14,9	58,7	45,4	15,2	58,9
	10	54,1	14,3	66,4	48,6	15,0	61,8	46,4	15,3	59,9
013.1	4	52,7	15,7	66,6	48,3	16,0	62,4	45,6	17,3	60,8
	5	54,3	15,7	68,3	49,8	16,1	63,9	47,4	17,4	62,6
	6	55,5	15,7	69,7	51,3	16,3	65,5	51,2	17,4	66,4
	7	57,1	15,8	71,3	52,7	16,3	67,0	51,3	17,6	66,5
	8	58,7	15,9	72,5	54,2	16,4	68,5	52,7	17,6	67,6
	9	62,0	15,9	75,8	56,8	16,6	71,3	52,7	17,7	68,0
	10	63,6	15,9	77,6	58,3	16,6	72,7	54,1	17,9	69,5
017.1	4	62,3	20,3	80,5	57,3	21,6	76,6	54,6	22,7	74,6
	5	64,2	20,4	82,5	59,1	21,8	78,5	56,2	23,0	76,4
	6	66,2	20,5	84,5	60,7	22,0	80,3	57,8	23,2	78,1
	7	67,9	20,6	86,3	62,5	22,2	82,1	59,5	23,3	79,9
	8	69,8	20,9	88,4	65,4	22,5	85,3	61,1	23,4	81,5
	9	71,8	21,1	90,5	67,3	22,5	87,3	64,1	23,5	84,5
	10	73,7	21,3	94,7	69,1	22,7	88,9	65,8	23,8	86,5
020.1	4	72,9	24,9	95,4	71,4	26,3	94,8	67,3	27,7	92,3
	5	75,1	25,1	97,8	73,5	26,7	97,2	71,4	28,0	95,6
	6	77,2	25,2	100,1	75,5	26,9	99,3	73,5	28,3	97,9
	7	79,3	25,5	102,4	79,7	27,2	103,7	74,8	29,2	100,3
	8	81,6	25,5	104,0	82,0	27,2	106,2	76,9	28,3	101,5
	9	83,7	25,7	106,4	84,1	27,5	108,0	78,9	28,7	103,9
	10	85,9	25,7	108,9	86,4	27,5	110,5	82,6	28,4	107,1
022.2	4	86,3	27,3	110,8	80,2	28,8	105,7	75,5	30,3	102,1
	5	88,9	27,6	113,6	82,6	29,1	108,3	77,8	30,6	104,6
	6	91,5	27,9	116,4	85,0	29,4	110,9	80,1	30,9	107,1
	7	91,7	28,1	117,0	87,5	29,6	113,5	82,4	31,1	109,6
	8	94,2	28,3	119,2	92,1	29,9	118,3	86,8	31,1	113,8
	9	94,4	28,3	119,9	94,4	30,2	120,8	89,3	31,4	116,5
	10	96,9	28,5	122,1	96,9	30,5	123,6	91,7	31,7	119,1

- Notes:** (1) Rating based on: evaporator fouling factor of 0,044 m<sup>2</sup> °C/ kW, evaporator temperature drop of 5°C and sea level altitude.  
(2) Interpolation is allowed, extrapolation is not permitted. Please contact McQuay for performance outside the standard ratings.  
(3) The power input values are referred to compressor only.

## Total heat recovery ratings ALZ “B” 025.2÷038.2 HFC 407C

Unit size HFC 407C	Evaporator leaving temp. (°C)	LEAVING HEAT RECOVERY CONDENSER WATER TEMPERATURE								
		40			45			50		
		Cooling capacity (kW)	Power input (kW)	Heating capacity (kW)	Cooling capacity (kW)	Power input (kW)	Heating capacity (kW)	Cooling capacity (kW)	Power input (kW)	Heating capacity (kW)
025.2	4	94,8	35,8	127,3	92,2	35,1	123,6	85,3	37,0	118,0
	5	97,6	35,8	130,1	94,9	35,4	126,4	87,8	37,2	120,7
	6	100,5	36,1	133,2	97,7	35,7	129,5	90,4	37,3	123,6
	7	103,3	36,2	136,2	100,4	35,8	132,4	93,9	37,6	126,5
	8	107,1	36,3	139,6	105,2	36,1	136,7	96,5	37,7	129,4
	9	109,0	36,5	142,2	108,0	36,1	139,8	99,1	38,0	132,3
	10	110,0	36,5	142,8	111,0	36,5	143,1	103,9	38,0	136,9
029.2	4	113,4	39,0	148,6	105,6	40,6	141,8	99,7	42,7	137,5
	5	116,7	39,3	152,1	108,6	41,0	145,2	104,6	43,1	142,6
	6	117,1	39,8	154,6	111,8	41,0	149,1	107,7	43,7	146,0
	7	120,1	40,2	155,9	116,1	41,5	152,4	110,7	43,7	149,4
	8	120,4	41,0	158,2	119,3	41,9	155,9	113,8	44,1	152,0
	9	123,7	41,5	159,8	123,7	41,9	160,6	114,7	44,2	153,3
	10	136,2	42,0	172,8	126,9	42,0	163,9	118,6	44,7	157,6
033.2	4	121,3	44,9	162,1	112,9	47,0	155,1	106,7	49,3	150,5
	5	124,8	45,4	166,0	116,2	47,3	158,7	109,8	49,8	154,0
	6	125,1	45,9	168,8	119,5	47,5	162,4	115,1	50,4	159,7
	7	128,4	46,7	170,0	123,9	47,9	166,3	118,3	50,6	163,3
	8	134,3	47,1	178,3	127,3	48,1	170,1	121,4	51,0	166,0
	9	141,4	48,0	183,4	131,8	48,1	174,5	123,4	51,2	168,5
	10	145,1	48,6	187,4	135,3	48,7	178,4	126,6	51,8	172,2
036.2	4	135,4	44,4	174,7	128,6	49,5	173,1	124,6	49,6	169,5
	5	139,5	45,2	179,3	132,4	50,2	177,6	132,3	50,1	177,5
	6	143,4	45,5	183,4	136,2	50,6	181,6	136,3	50,6	181,9
	7	151,5	46,0	191,8	143,9	51,2	189,6	138,8	52,3	185,9
	8	155,9	46,0	196,1	148,0	51,2	193,7	142,6	50,7	188,1
	9	160,0	46,5	200,5	152,0	51,7	198,0	146,8	51,2	192,6
	10	164,6	46,5	204,9	156,3	51,7	202,2	153,7	50,7	198,9
038.2	4	146,2	48,4	189,0	138,8	53,8	187,3	134,1	55,0	184,0
	5	150,9	48,9	194,0	143,3	54,4	192,2	139,1	55,6	189,5
	6	155,1	49,7	198,9	147,3	55,3	196,9	150,0	55,5	200,0
	7	159,3	49,8	203,0	151,3	55,4	200,9	150,5	56,5	201,3
	8	163,7	50,2	207,7	155,5	55,8	205,4	154,4	56,4	205,2
	9	171,6	50,9	216,1	163,0	56,5	213,4	154,0	57,1	205,4
	10	175,8	51,2	220,4	167,0	56,8	217,5	158,3	57,7	210,2

- Notes:**
- (1) Rating based on: evaporator fouling factor of 0,044 m<sup>2</sup> °C/ kW, evaporator temperature drop of 5°C and sea level altitude.
  - (2) Interpolation is allowed, extrapolation is not permitted. Please contact McQuay for performance outside the standard ratings.
  - (3) The power input values are referred to compressor only.

## Standard ratings motocondensing units ALP “B” 011.1÷022.2 HFC 407C

Unit size HFC 407C	Evaporation temperature °C	AMBIENT TEMPERATURE - °C									
		25		30		32		35		40	
		Cooling capacity (kW)	Power input (kW)	Cooling capacity (kW)	Power input (kW)	Cooling capacity (kW)	Power input (kW)	Cooling capacity (kW)	Power input (kW)	Cooling capacity (kW)	Power input (kW)
011.1	0	44,1	14,2	41,5	14,6	40,4	14,7	38,8	15,0	35,9	15,3
	2	47,0	14,8	44,2	15,2	43,0	15,3	41,4	15,6	38,4	16,0
	4	49,9	15,3	46,8	15,7	45,5	15,8	44,0	16,2	41,0	16,7
	6	52,8	15,9	49,5	16,3	48,1	16,4	46,6	16,8	43,5	17,4
	8	55,7	16,5	52,1	16,9	50,6	17,0	49,3	17,5	46,1	18,1
	10	58,6	17,0	54,8	17,4	53,2	17,5	51,9	18,1	48,6	18,8
013.1	0	51,9	16,1	48,9	16,5	47,7	16,6	45,7	16,9	42,3	17,3
	2	55,3	16,7	52,0	17,1	50,7	17,2	48,8	17,6	45,3	18,1
	4	58,9	17,2	55,1	17,7	53,6	17,9	51,9	18,3	48,3	18,9
	6	62,1	17,8	58,3	18,3	56,7	18,5	54,9	19,0	51,3	19,7
	8	65,7	18,6	61,4	19,0	59,7	19,1	58,1	19,7	54,3	20,4
	10	69,2	19,2	64,6	19,6	62,7	19,7	61,1	20,4	57,3	21,2
017.1	0	63,9	20,9	60,1	21,4	58,6	21,6	56,2	22,0	52,0	22,5
	2	68,1	21,7	64,0	22,2	62,3	22,4	60,0	22,9	55,7	23,5
	4	72,3	22,5	67,8	23,0	66,0	23,2	63,8	23,8	59,4	24,6
	6	76,5	23,2	71,7	23,9	69,7	24,1	67,6	24,7	63,1	25,6
	8	80,8	24,0	75,5	24,7	73,4	24,9	71,4	25,6	66,8	26,6
	10	85,1	25,0	79,3	25,5	77,0	25,7	75,2	26,6	70,4	27,6
020.1	0	75,0	26,0	70,7	26,7	68,9	27,0	66,1	27,5	61,1	28,1
	2	80,0	27,1	75,2	27,8	73,2	28,0	70,5	28,6	65,4	29,4
	4	85,0	28,1	79,7	28,8	77,5	29,0	74,9	29,7	69,7	30,7
	6	90,0	29,1	84,2	29,8	81,9	30,1	79,4	30,9	74,1	32,0
	8	95,0	30,1	88,7	30,8	86,2	31,1	83,9	32,0	78,4	33,2
	10	100,0	31,1	93,2	31,8	90,5	32,1	88,3	33,2	82,8	34,5
022.2	0	90,6	29,5	84,8	27,2	82,4	26,2	79,1	29,2	73,1	30,5
	2	95,7	30,9	90,1	28,3	87,8	27,2	84,1	30,5	78,0	31,9
	4	100,9	32,1	95,4	29,3	93,2	28,2	89,1	31,8	83,0	33,2
	6	106,0	33,3	100,7	30,5	98,5	29,3	94,3	33,1	88,0	34,6
	8	111,0	34,5	106,0	31,5	104,0	30,3	99,3	34,3	92,9	36,0
	10	116,3	35,7	111,3	32,6	109,3	31,3	104,5	35,6	97,8	37,3

**Notes:** (1) Interpolation is allowed, extrapolation is not permitted. Please contact McQuay for performance outside the standard ratings.  
 (2) The power input values are referred to compressor only.

## Standard ratings motocondensing units ALP “B” 025.2÷038.2 HFC 407C

Unit size HFC 407C	Evaporation temperature °C	AMBIENT TEMPERATURE - °C									
		25		30		32		35		40	
		Cooling capacity (kW)	Power input (kW)	Cooling capacity (kW)	Power input (kW)	Cooling capacity (kW)	Power input (kW)	Cooling capacity (kW)	Power input (kW)	Cooling capacity (kW)	Power input (kW)
025.2	0	100,9	36,5	94,6	33,5	92,0	32,3	88,2	36,0	81,6	37,6
	2	106,8	38,1	100,5	34,8	97,9	33,5	93,8	37,6	87,0	39,3
	4	112,7	39,5	106,4	36,2	103,9	34,8	99,4	39,2	92,5	41,0
	6	118,1	41,0	112,3	37,5	109,9	36,1	105,1	40,8	98,1	42,7
	8	124,0	42,5	118,2	38,9	115,9	37,4	110,8	42,3	103,6	44,3
	10	129,8	44,0	124,2	40,2	121,9	38,6	116,5	43,9	109,1	46,0
029.2	0	114,7	42,0	107,4	38,5	104,4	37,1	100,1	41,4	92,6	43,2
	2	121,2	43,8	114,1	40,0	111,2	38,5	106,5	43,2	98,8	45,1
	4	127,8	45,4	120,8	41,6	118,0	40,0	112,9	45,0	105,1	47,1
	6	134,3	47,1	127,5	43,1	124,8	41,5	119,4	46,8	111,4	49,0
	8	141,2	44,0	134,4	43,4	131,6	43,1	126,3	48,1	129,8	50,6
	10	146,7	45,6	140,9	45,0	138,5	44,7	133,1	49,5	136,8	52,2
033.2	0	122,4	48,5	114,6	44,5	111,5	42,9	106,9	47,9	98,9	50,0
	2	129,4	50,6	121,8	46,3	118,7	44,6	113,7	50,0	105,5	52,3
	4	136,6	52,6	129,0	48,1	125,9	46,3	120,5	52,1	112,2	54,5
	6	143,2	54,5	136,1	49,9	133,2	48,0	127,5	54,2	118,9	56,7
	8	149,6	56,1	142,8	51,5	140,1	49,6	134,5	55,8	125,5	58,1
	10	156,9	57,7	149,8	53,1	146,9	51,2	141,2	57,1	132,4	59,8
036.2	0	134,8	50,7	127,7	50,6	124,8	50,5	122,6	48,9	113,2	50,0
	2	143,5	52,4	135,7	52,4	132,6	52,4	130,9	51,0	121,3	52,2
	4	152,4	54,6	144,1	54,3	140,7	54,2	139,3	53,0	129,3	54,7
	6	161,4	56,2	152,3	56,4	148,6	56,5	147,3	55,1	137,4	57,0
	8	170,3	58,2	160,5	58,4	156,5	58,4	155,6	57,1	145,4	59,2
	10	179,5	60,6	168,5	60,3	164,1	60,2	163,9	59,4	153,3	61,5
038.2	0	147,4	55,9	139,6	55,8	136,5	55,7	134,1	54,0	123,9	55,0
	2	156,7	57,9	148,4	57,9	145,0	57,9	143,0	56,4	132,6	57,5
	4	166,3	60,3	157,3	60,0	153,7	59,9	152,1	58,6	141,2	60,3
	6	176,0	62,2	166,2	62,4	162,2	62,4	160,8	60,9	149,9	62,8
	8	185,7	64,3	175,1	64,5	170,8	64,5	169,8	63,1	158,7	65,3
	10	195,7	67,0	183,9	66,7	179,2	66,6	178,9	65,5	167,2	67,7

**Notes:** (1) Interpolation is allowed, extrapolation is not permitted. Please contact McQuay for performance outside the standard ratings.  
(2) The power input values are referred to compressor only.



# Evaporator pressure drops

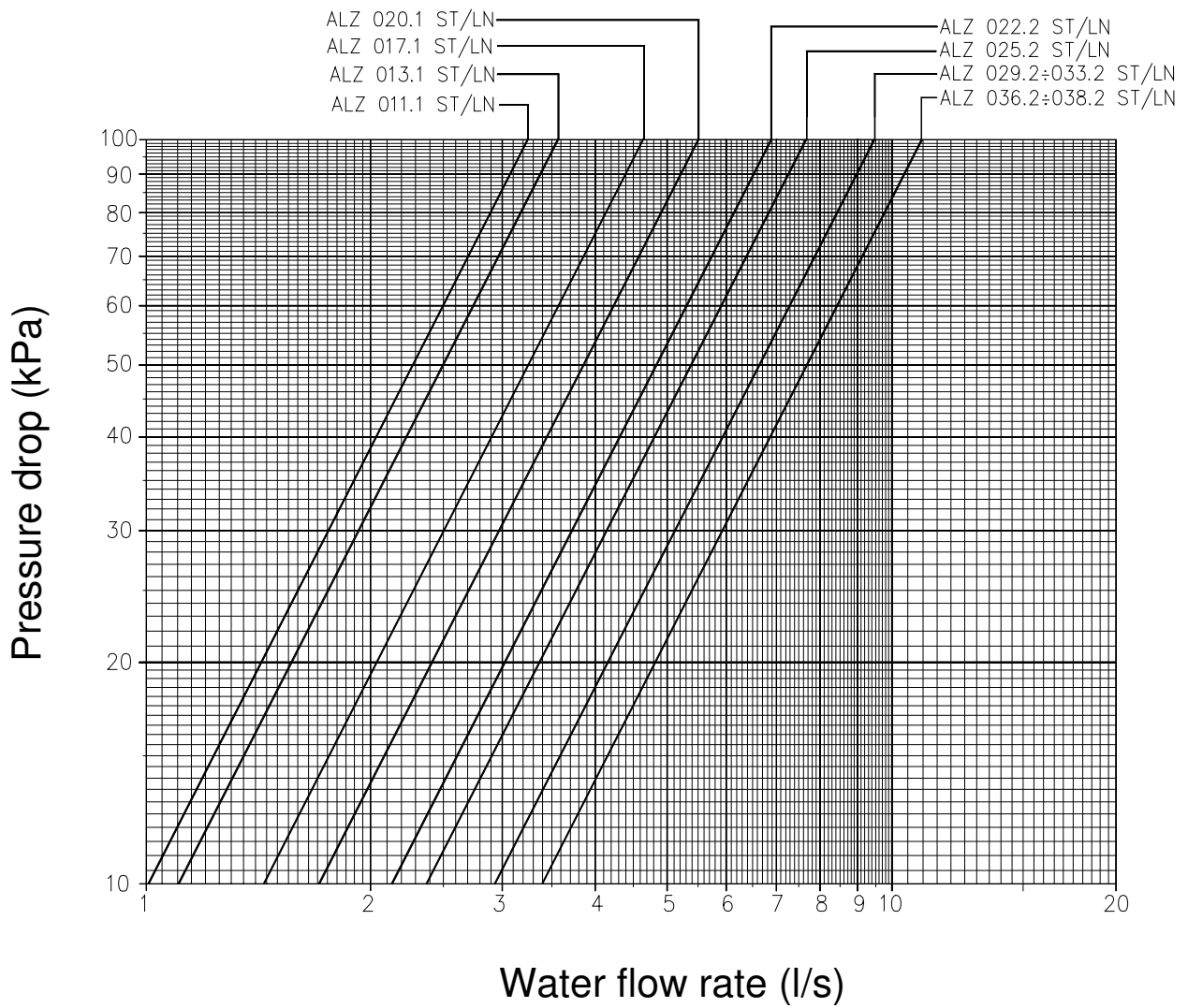

# Water pump diagrams

## Type “A” water pump

Standard voltage 400/3/50 – Motor power 0,75 kW – Absorbed current 2,3 A – IP 55

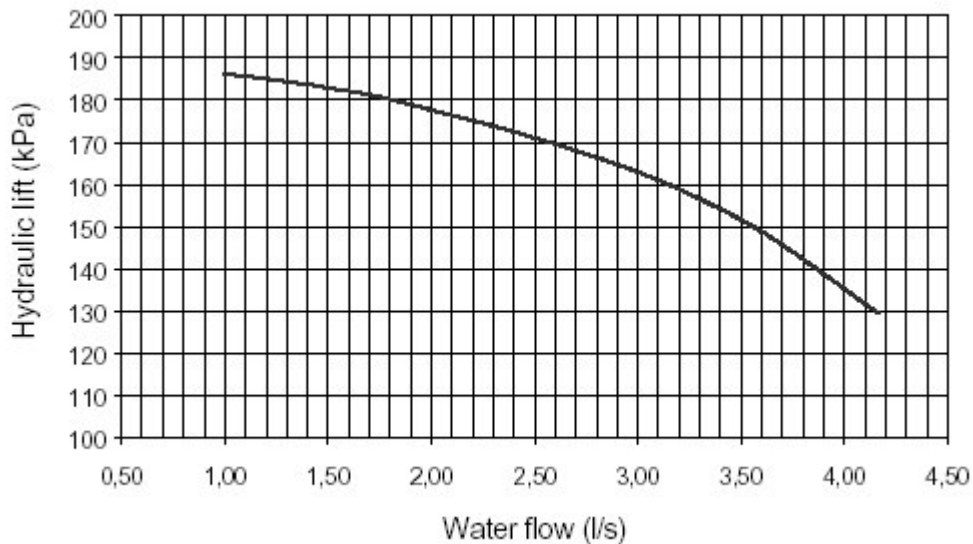

## Type “B” water pump

Standard voltage 400/3/50 – Motor power 1,5 kW – Absorbed current 4,3 A – IP 55

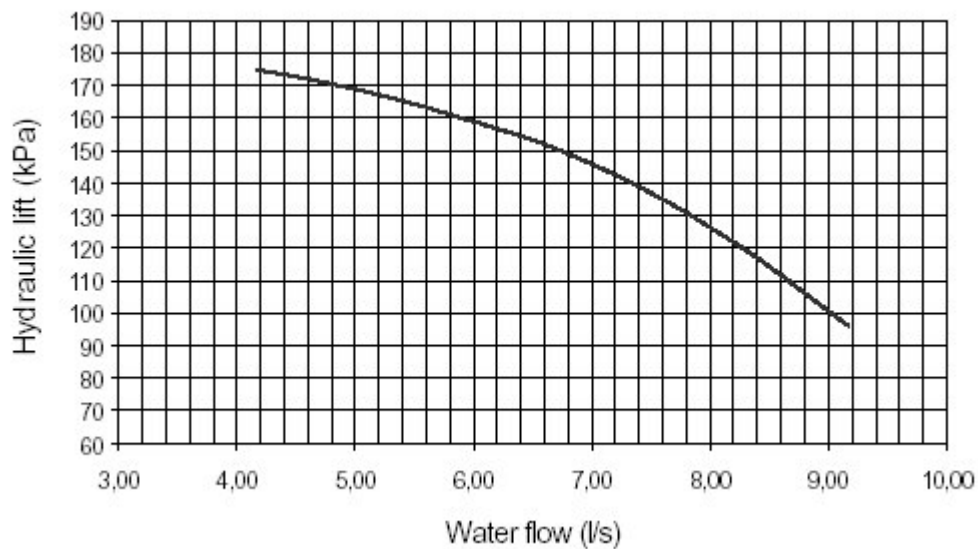

**N.B.** In order to get the net hydraulic lift, subtract the evaporator pressure drop from diagram value. When you order the unit with the water pump and tank, you must specify the selected type: A or B.

## ALZ "B" / ALP "B" unit dimensions

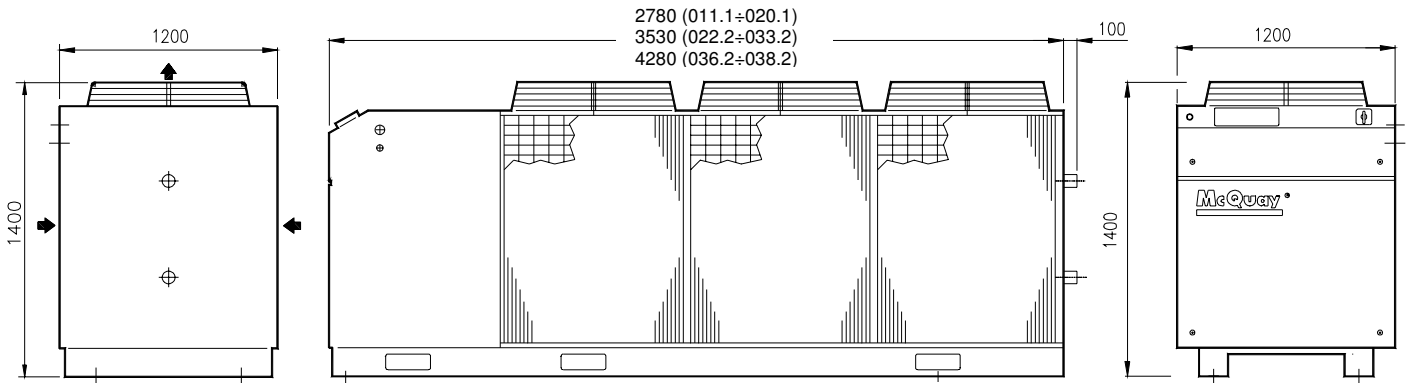

## Fans arrangement

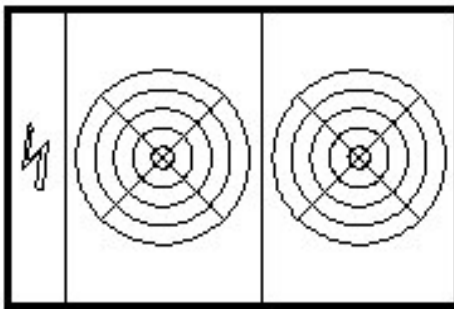

ALZ/ALP "B" 011.1 ÷ 020.1

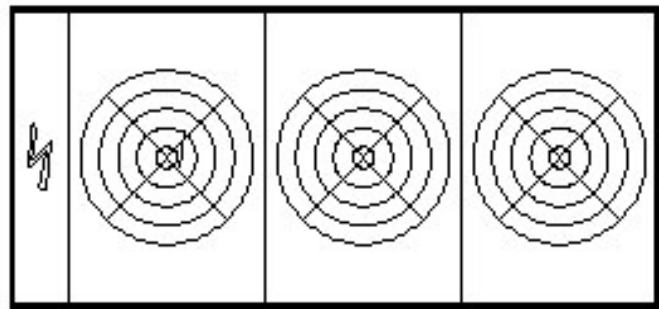

ALZ/ALP "B" 022.2 ÷ 033.2

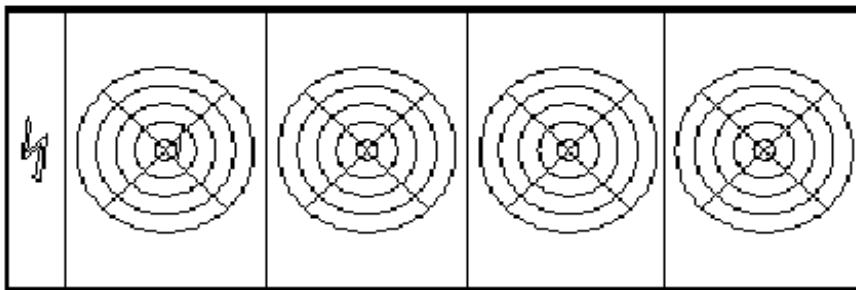

ALZ/ALP "B" 036.2 – 038.2

We reserve the right to make changes in design and construction at any time without notice, thus the cover picture is not binding.

McQuay partecipa al programma di  
Certificazione Eurovent.  
I prodotti interessati figurano nella Guida  
Eurovent dei Prodotti Certificati.



McQuay is participating in the Eurovent  
Certification Programme  
Product are as listed in the Eurovent  
Directory of Certified Products

**McQuay**<sup>®</sup>  
International

McQuay Italia S.P.A.  
S.S. Nettunense, km 12+300 – 00040 Cecchina (Roma) Italia – Tel. (06) 937311 – Fax (06) 9374014 – email: [info@mcquayeuropa.com](mailto:info@mcquayeuropa.com)  
[www.mcquayeuropa.com](http://www.mcquayeuropa.com)