

Fan Coil Units

Models: MWM-FW Series
MCM-DW Series
MCK-AW/BW Series
MCC-CW Series
MDB-BW Series



Contents

Features	1
Specifications	3
Unit Selection Procedure	11
Cooling Capacity Performance Chart	14
Heating Capacity Performance Chart.....	48
Water Flow Rate Vs Pressure Drop	66
Correction Factors	71
Wiring Diagrams	72
Controllers	78
Blower Performance Curves	84
Outlines And Dimensions	98
General Installation Guide	110
General Operation Guide	116

Note : Installation and maintenance are to be performed only by qualified personnel who are familiar with local codes and regulations, and experienced with this type of equipment.

Caution: Sharp edges and coil surfaces are a potential injury hazard. Avoid contact with them.

Warning : Moving machinery and electrical power hazard. May cause severe personal injury or death. Disconnect and lock off power before servicing equipment.

"McQuay" is a registered trademark of McQuay International. All rights reserved throughout the world.

©2003 McQuay International

"Bulletin illustrations cover the general appearance of McQuay International products at the time of publication and we reserve the right to make changes in design and construction at any time without notice."

Features

Space Saving

Different types of fan coil units are designed to be both versatile and space saving to suit every interior design. Ceiling concealed type for the sophisticated, luxurious floor space saving, all kind of interior decoration; ceiling exposed type for economical and space saving installation; etc.

Zone Control

These fan coil units can be installed in different zones as each unit operates independently. Zone control on energy saving, different comfort requirement; better air distribution needs can therefore be easily achieved.

Standardisation Of Fan Coil Unit Control

The fan coil unit controller is standardized using W1V3 I.C, which enables the selection of valve / valveless and cooling / heating applications. This allows the user to choose the desired application by just plugging in or removing the jumpers at certain connectors on the PCB. The advantages of these units are lesser inventory for finished goods stock and spare parts. For more details, please refer to **General Installation guide**.

Unique Features For MWM-FW Series

Easy Installation

The wall mounted fan coil unit is easily installed because of its compact size, slimness and light weight. Slim and short outdoor unit can be easily installed even in a narrow balcony and passageway and yet have a stable profile.

Space Saving

No space is required on either floor or ceiling. This newly developed super slim design for wall mounting maximises floor space usage and enhance ceiling appearance where ceilings are low.

Quiet Operation

Cooling comfort is improved by whisper-quiet operation which is achieved by a tangential fan.

Excellent Air Distribution

Air discharge direction can be adjusted in four directions, manually or automatically by using LCD remote control, coupled with good air flow, the unit provides excellent air distribution.

Facilitated Maintenance Ensured

The new design cassette filter is slide-out type which can be easily removed at the air inlet grille for cleaning. Maintenance is easy for electrical components, piping and wiring as these are all easily accessible by merely removing front plastic panel.

Wireless Remote Control

The compact LCD transmitter is able to operate the air conditioner unit within the distance of 9 meters. Fan motor speed can be set at low/medium/high or automatic. Sleep mode automatically increase set temperature since room temperature is lower at night thus achieving comfort surrounding. Air flow direction can be controlled automatically. Room temperature is controlled by electronic thermostat. The unit can be preset to on and off automatically for maximum of 15 hours by using timer on/off.

Slit Fin

The unique Hydrophilic slit fin has greatly improved the air flow and the contact surfaces with the air thus to boost the cooling capacity.

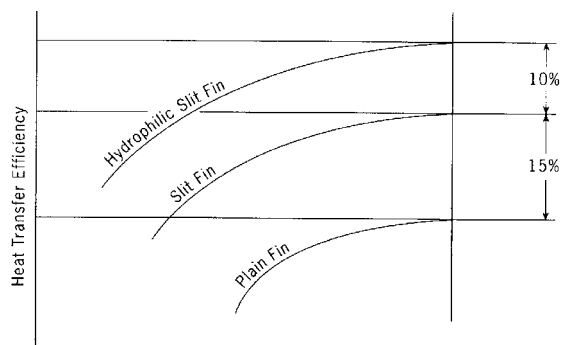

Unique Features For MCK-AW/BW Series

Built In High Head Drain Pump

The unit comes with a built in high head drain pump. Condensate water can be pumped up to 500mm and drain out smoothly.

4-Way Air Discharge And Air Swing

These features greatly improve the air distribution in the conditioned space.

Wireless And Wired Controller Option

Wireless Handset is the standard controller. However if wired controller required, Netware2 & SLM3 wired controller is a wise choice(optional).

Unique Features For MCM-DW Series

2-Way Air Discharge And Air Swing

The 2-way air discharge couple with the air swing function, provide better air distribution in the conditioned space.

Easy Maintenance

The air filter and components can be easily accessed from the bottom of the unit. This make servicing and maintenance become a simple task.

Wireless And Wired Controller Option

Wireless Handset is the standard controller. However if wired controller required, Netware2 & SLM3 wired controller is a wise choice(optional).

Unique Features For MCC-CW Series

Elegance And Prestige

As the unit is installed above the ceiling with only the supply and return air grille exposed to view, the air conditioned space will appear as elegant and prestigious as a centralized air conditioned area.

Evergreen Design

This unit will never become obsolete as the unit is completely concealed away. Interior decoration for maximum aesthetic beauty as well as interior design is easily achieved.

Superior Air Distribution

As the conditioned air can be distributed to every corner of the area by air duct, this will ensure more pleasant living environment, thus provide extra comfort to the occupants.

Optional Duct Accessories

The optional duct accessories makes the ducting and installation work so easy.

Wired Controller

Netware2 & SLM3 wired controller offers simple and flexibility in controlling the unit.

Unique Features For MDB-BW Series

Superb Air Distribution

These units are designed with high air flow and static, enables adequate distribution of air to the desired space. Providing comfort to every corner of the room.

Reliability

The structures are strong and robust to ensure the product operation life.

Versatile

Multiple rooms can be cooled together by just using one unit of MDB.

Specifications

WALL MOUNTED TYPE

MODEL		MWM						
		005FW	007FW	010FW	015FW	020FW	025FW	
PERFORMANCE								
Air Flow (CFM/CMH)	High	200 / 340	200 / 340	270 / 460	300 / 510	480 / 816	580 / 985	
	Medium	170 / 289	170 / 289	230 / 390	270 / 460	430 / 730	485 / 824	
	Low	140 / 238	140 / 238	190 / 320	230 / 390	370 / 630	380 / 645	
Nominal Total Cooling Capacity	kcal/hr	1,210	1,638	2,520	3,024	4,284	5,292	
	W	1,410	1,910	2,931	3,517	4,982	6,154	
	Btu/hr	4,800	6,500	10,000	12,000	17,000	21,000	
Sensible Cooling Capacity	kcal/hr	1,179	1,373	1,739	2,026	2,956	3,651	
	W	1,375	1,600	2,022	2,356	3,438	4,247	
	Btu/hr	4,680	5,447	6,900	8,040	11,730	14,490	
Nominal Total Heating Capacity (Entering water Temp. : 60°C)	kcal/hr	2,650	3,000	4,110	4,540	6,450	7,990	
	W	3,080	3,490	4,780	5,275	7,500	9,290	
	Btu/hr	10,500	11,900	16,300	18,000	25,600	31,700	
Water Flow Rate	USGPM / LITRES/M	0.95 / 3.59	1.29 / 4.88	1.98 / 7.48	2.38 / 9.00	3.37 / 12.74	4.17 / 15.76	
Differential Pressure Drop	Cooling	kPa	5.6	9.5	49.7	69.1	21.3	31.1
	Heating	kPa	4.7	7.9	41.4	57.6	17.7	25.9
COIL								
Type	Seamless copper tube mechanically boded to aluminium slit fin.							
Tube	OD 7.00 mm, thickness 0.35 mm.							
Fin	thickness 0.11 mm							
Connection	OD 1/2" copper tube							
Number of rows / fin per inch		1 / 18	1 / 20	2 / 18	2 / 18	2 / 18	2 / 18	
Max. Working Pressure	(kg/cm ²) / (psi)	16.4 / 233						
Testing Pressure	30 kg/cm ² for 1 min, leak test : 16 kg/cm ² for 5 min.							
Surface Area	m ² / ft ²	0.208 / 2.239	0.208 / 2.239	0.198 / 2.131	0.198 / 2.131	0.254 / 2.733	0.254 / 2.733	
Surface Air Velocity	(m/s) / (ft/min)	0.69 / 135.84	0.69 / 135.84	0.64 / 126.70	0.72 / 140.78	0.89 / 175.63	1.08 / 212.22	
MOTOR								
Type	Permanent split capacitor motor							
Power Supply	V/Ph/Hz	220 - 240 / 1 / 50 , 208 - 230 / 1 / 60						
Rated Input Power	W (50/60Hz)	25 / -	25 / -	25 / 26	25 / 26	53 / 67	57 / 81	
Rated Running Current	A (50/60Hz)	0.11 / -	0.11 / -	0.11 / 0.12	0.11 / 0.12	0.23 / 0.31	0.24 / 0.38	
Poles		4						
Sound Pressure Level (H/M/L)	dBA	37 / 33 / 28	38 / 34 / 30	38 / 34 / 30	38 / 35 / 31	45 / 42 / 39	47 / 44 / 42	
Control	Room Temp.	Micro-computer Controlled Thermostat						
	Air Discharge	Automatic Louver (Up & Down)						
	Operation	LCD wireless micro-computer remote control						
Condensate Drain Size	mm	19.05						
AIR FILTER								
Washable Saranet Filter								
WEIGHT	kg	12	12	12	12	15	15	
DIMENSION (H x W x D)	mm	290 x 815 x 179				306 x 1,062 x 202		

Condition

Cooling capacity : Entering air temp. : 26.7 °C (80 °F) DB, 19.4 °C (67 °F) WB
 Entering water temp. : 7.2 °C (45 °F)
 Leaving water temp. : 12.8 °C (55 °F)

Heating capacity : Entering air temp. : 21.1 °C (64 °F) DB
 Entering water temp. : 60 °C (140 °F)

Microphone position : 1m in front of the unit & 0.8m below the vertical centre line of the unit. (JIS C 9612)

CEILING CASSETTE TYPE

MODEL		MCK					
		020AW	025AW	030AW	040AW	050AW	
PERFORMANCE							
Air Flow (CFM/CMH)	High	770 / 1,310	810 / 1,380	920 / 1,560	1,020 / 1,740	1,080 / 1,840	
	Medium	650 / 1,100	700 / 1,190	770 / 1,320	900 / 1,530	990 / 1,680	
	Low	630 / 1,070	630 / 1,070	700 / 1,190	790 / 1,340	910 / 1,540	
Nominal Total Cooling Capacity	kcal/hr	6,048	6,804	7,964	9,073	9,829	
	W	7,034	7,913	9,261	10,551	11,430	
	Btu/hr	24,000	27,000	31,600	36,000	39,000	
Sensible Cooling Capacity	kcal/hr	4,209	4,738	5,494	6,162	6,628	
	W	4,894	5,510	6,389	7,166	7,708	
	Btu/hr	16,700	18,800	21,800	24,450	26,300	
Nominal Total Heating Capacity (Entering water Temp. : 60°C)	kcal/hr	9,550	10,485	12,045	13,330	13,860	
	W	11,100	12,190	14,000	15,500	16,120	
	Btu/hr	37,879	41,600	47,800	52,900	55,000	
Water Flow Rate	USGPM / LITRES/M	4.76 / 18.00	5.36 / 20.26	6.27 / 23.70	7.14 / 26.99	7.74 / 29.26	
Differential Pressure Drop	Cooling	kPa	15.9	19.7	26.3	33.5	38.9
	Heating	kPa	13.3	16.4	21.9	27.9	32.4
COIL							
Type	Seamless copper tube mechanically boded to aluminium slit fin.						
Tube	OD 9.52 mm, thickness 0.35 mm.						
Fin	thickness 0.11 mm						
Connection	OD 3/4" copper tube						
Number of rows / fin per inch		2/12	2/14	2/16	2/16	2/16	
Max. Working Pressure	(kg/cm ²) / (psi)	16.4 / 233					
Testing Pressure	30 kg/cm ² for 1 min, leak test : 16 kg/cm ² for 5 min.						
Surface Area	m ² / ft ²	0.459 / 5.022	0.459 / 5.022	0.459 / 5.022	0.459 / 5.022	0.459 / 5.022	
Surface Air Velocity	(m/s) / (ft/min)	0.78 / 153.33	0.82 / 161.29	0.93 / 183.19	1.03 / 203.11	1.09 / 215.05	
MOTOR							
Type	Permanent split capacitor motor						
Power Supply	V/Ph/Hz	220 - 240 / 1 / 50 , 208-230/1/60					
Rated Input Power	W (50/60Hz)	127 / 139	151 / 163	164 / 208	192 / 321	253 / 328	
Rated Running Current	A (50/60Hz)	0.53 / 0.64	0.65 / 0.75	0.69 / 0.98	0.80 / 1.50	1.08 / 1.50	
Poles		6					
Sound Pressure Level (H/M/L)	dBA	42 / 39 / 37	45 / 42 / 40	49 / 45 / 43	51 / 48 / 46	53 / 52 / 50	
Control	Room Temp.	Micro-computer Controlled Thermostat					
	Air Discharge	Automatic Louver (Up & Down)					
	Operation	LCD wireless micro-computer remote control					
Condensate Drain Size	mm	19.05					
AIR FILTER							
Washable Saranet Filter							
WEIGHT (unit + panel)	kg	31+ 4	32 +4	35 + 4	38 + 4	40 + 4	
DIMENSION - H x W x D () - with panel	mm	335x820x820 (363x930x930)					

Condition

Cooling capacity : Entering air temp. : 26.7°C (80°F)DB, 19.4C (67°F)WB
 Entering water temp. : 7.2°C (45°F)
 Leaving water temp. : 12.8°C (55°F)

Heating capacity : Entering air temp. : 21.1°C (64°F)DB
 Entering water temp. : 60°C (140°F)

Microphone position : MCK 020AW / 025AW -- 1.4m below the facia. (JIS C 9612)
 MCK 030AW / 040AW / 050AW -- 1.5 m below the facia. (JIS B 8615)

CEILING CASSETTE TYPE

MODEL		MCK				
		015BW	020BW	025BW	030BW	
PERFORMANCE						
Air Flow (CFM/CMH)	High	430 / 731	430 / 731	500 / 850	607 / 1,031	
	Medium	370 / 629	370 / 629	450 / 765	537 / 912	
	Low	310 / 527	310 / 527	390 / 663	475 / 807	
Nominal Total Cooling Capacity	kcal/hr	3,150	4,284	5,040	5,796	
	W	3,660	4,977	5,860	6,740	
	Btu/hr	12,500	17,000	20,000	23,000	
Sensible Cooling Capacity	kcal/hr	2,331	2,853	3,352	3,871	
	W	2,711	3,318	3,898	4,502	
	Btu/hr	9,250	11,320	13,300	15,360	
Nominal Total Heating Capacity (Entering water Temp. : 60°C)	kcal/hr	5,040	6,050	6,930	8,060	
	W	5,860	7,030	8,060	9,380	
	Btu/hr	20,000	24,000	27,500	32,000	
Water Flow Rate		USGPM / LITRES/M	2.48 / 9.37	3.37 / 12.74	3.97 / 15.00	4.56 / 17.24
Differential Pressure Drop	Cooling	kPa	2.2	7.4	9.9	12.7
	Heating	kPa	1.8	6.2	8.3	9.4
COIL						
Type		Seamless copper tube mechanically boded to aluminium slit fin.				
Tube		OD 9.52 mm, thickness 0.35 mm.				
Fin		thickness 0.11 mm				
Connection		OD 3/4" copper tube				
Number of rows / fin per inch		1/18	2/14	2/14	2/14	
Max. Working Pressure		(kg/cm ²) / (psi)	16.4 / 233			
Testing Pressure		30 kg/cm ² for 1 min, leak test : 16 kg/cm ² for 5 min.				
Surface Area		m ² / ft ²	0.431 / 4.637	0.416 / 4.483	0.416 / 4.483	0.416 / 4.483
Surface Air Velocity		(m/s) / (ft/min)	0.471 / 92.73	0.487 / 95.91	0.567 / 111.53	0.688 / 135.40
MOTOR						
Type		Permanent split capacitor motor				
Power Supply		V/Ph/Hz	220 - 240 / 1 / 50 , 208-230/1/60			
Rated Input Power		W (50/60Hz)	72 / 73	79 / 88	108	
Rated Running Current		A (50/60Hz)	0.31 / 0.34	0.31 / 0.34	0.33 / 0.41	0.45 / 0.5
Poles		6				
Sound Pressure Level (H/M/L)		dBA	41 / 38 / 36	42 / 40 / 37	45 / 42 / 39	48 / 45 / 42
Control	Room Temp.	Micro-computer Controlled Thermostat				
	Air Discharge	Automatic Louver (Up & Down)				
	Operation	LCD wireless micro-computer remote control				
Condensate Drain Size		mm	19.05			
AIR FILTER		Washable Saranet Filter				
WEIGHT (unit + panel)		kg	30 + 3	30 + 3	31 + 3	32 + 3
DIMENSION - H x W x D () - with panel		mm	293 x 650 x 650 (363 x 930 x 930)			

Condition
Cooling capacity : Entering air temp. : 26.7 °C (80 °F) DB, 19.4 °C (67 °F) WB
Entering water temp. : 7.2 °C (45 °F)
Leaving water temp. : 12.8 °C (55 °F)

Heating capacity : Entering air temp. : 21.1 °C (64 °F) DB
Entering water temp. : 60 °C (140 °F)

Microphone position : MCK 015BW/ 020BW/ 025BW - 1.4m below the fascia (JIS C 9612) ,
MCK 030BW - 1.5m below the fascia (JIS B 8615).

CEILING EXPOSED TYPE

MODEL		MCM					
		020DW	025DW	030DW	040DW	050DW	
PERFORMANCE							
Air Flow (CFM/CMH)	High	590 / 1,000	660 / 1,130	730 / 1,240	1,000 / 1,700	1,110 / 1,890	
	Medium	530 / 900	650 / 1,110	720 / 1,220	950 / 1,620	1,070 / 1,820	
	Low	420 / 710	580 / 990	680 / 1,160	930 / 1,580	1,000 / 1,700	
Nominal Total Cooling Capacity	kcal/hr	5,040	5,544	6,552	9,535	12,096	
	W	5,862	6,448	7,620	11,137	14,068	
	Btu/hr	20,000	22,000	26,000	38,000	48,000	
Sensible Cooling Capacity	kcal/hr	3,528	3,825	4,455	6,485	7,983	
	W	4,102	4,448	5,180	7,538	9,282	
	Btu/hr	14,000	15,180	17,680	25,730	31,680	
Nominal Total Heating capacity (Entering water Temp. : 60 °C)	kcal/hr	7,535	8,215	9,525	16,030	16,885	
	W	8,760	9,550	11,075	18,635	19,630	
	Btu/hr	29,900	32,600	37,800	63,600	67,000	
Water Flow Rate	USGPM/LITRES/M	3.97 / 15.01	4.37 / 16.52	5.16 / 19.50	7.54 / 28.50	9.52 / 35.99	
Differential Pressure Drop	Cooling	kPa	16.5	19.7	17.8	8.9	13.4
	Heating	kPa	13.8	16.4	14.8	7.4	11.2
COIL							
Type	Seamless copper tube mechanically bonded to aluminium slit fin.						
Tube	OD 9.52 mm, thickness 0.35 mm.						
Fin	thickness 0.11 mm						
Connection	OD 3/4" copper tube						
Number of rows / fin per inch		3/12	3/12	3/12	4/12	4/14	
Max. Working Pressure	(kg/cm ²)/(psi)	16.4 / 233					
Testing Pressure	30 kg/cm ² for 1 min, leak test : 16 kg/cm ² for 5 min.						
Surface Area	m ² /ft ²	0.217 / 2.338	0.217 / 2.338	0.263 / 2.826	0.406 / 4.361	0.406 / 4.361	
Surface Air Velocity	(m/s)/(ft/min)	1.28 / 252.35	1.43 / 282.29	1.31 / 258.32	1.16 / 229.31	1.29 / 254.53	
MOTOR							
Type	Permanent split capacitor motor						
Power Supply	V/Ph/Hz	220 - 240 / 1 / 50 , 208-230 / 1 / 60					
Rated Input Power	W (50/60Hz)	96 / 114	130 / 155	132 / 179	240 / 337	240 / 337	
Rated Running Current	A (50/60Hz)	0.4 / 0.5	0.58 / 070	0.58 / 0.80	1.04 / 1.50	1.04 / 1.50	
Poles	4						
Sound pressure level (H/M/L)	dBA	50 / 47 / 40	54 / 53 / 50	51 / 50 / 48	54 / 53 / 52	54 / 53 / 52	
Control	Room Temp.	Micro-computer Controlled Thermostat					
	Air Discharge	Automatic Louver (Up & Down)					
	Operation	LCD wireless micro-computer remote control					
Condensate Drain Size	mm	19.05					
AIR FILTER							
Washable Saranet Filter							
WEIGHT	kg	43	43	45	70	70	
DIMENSION (HxWxD)	mm	214 x 1,214 x 670		249 x 1,214 x 670		249 x 1,714 x 670	

Condition

Cooling capacity : Entering air temp. : 26.7°C (80°F)DB, 19.4C (67°F)WB
 Entering water temp. : 7.2°C (45°F)
 Leaving water temp. : 12.8°C (55°F)

Heating capacity : Entering air temp. : 21.1°C (64°F)DB
 Entering water temp. : 60°C (140°F)

Microphone position : MCM 020DW / 025DW -- 1m in front of the unit & 0.8m below the air discharge opening. (JIS C 9612)
 MCM 030DW / 040DW / 050DW -- 1m in front of the unit & 1m below the air discharge opening. (JIS B 8615)

CEILING CONCEALED TYPE

MODEL		MCC				
		010CW	015CW	020CW	025CW	
PERFORMANCE						
Air Flow (CFM/CMH)	High	300 / 510	430 / 730	620 / 1,050	840 / 1,430	
	Medium	280 / 475	370 / 630	590 / 1,000	790 / 1,340	
	Low	240 / 410	270 / 460	500 / 850	640 / 1,090	
Nominal Total Cooling Capacity	kcal/hr	2,520	3,780	4,788	6,048	
	W	2,931	4,397	5,569	7,034	
	Btu/hr	10,000	15,000	19,000	24,000	
Sensible Cooling Capacity	kcal/hr	1,789	2,646	3,352	4,234	
	W	2,081	3,078	3,898	4,924	
	Btu/hr	7,100	10,500	13,300	16,800	
Nominal Total Heating Capacity (Entering water Temp. : 60°C)	kcal/hr	3,910	5,970	7,410	9,150	
	W	4,540	6,945	8,615	10,640	
	Btu/hr	15,500	23,700	29,400	36,300	
Water Flow Rate	USGPM / LITRES/M	1.98 / 7.48	2.98 / 11.26	3.77 / 14.25	4.76 / 17.99	
Differential Pressure Drop	Cooling	kPa	8.2	18.8	14.4	24.7
	Heating	kPa	6.8	15.7	12.0	20.6
COIL						
Type	Seamless copper tube mechanically boded to aluminium slit fin.					
Tube	OD 9.52 mm, thickness 0.35 mm.					
Fin	thickness 0.11 mm					
Connection	OD 3/4" copper tube					
Number of rows / fin per inch		3/12	3/14	3/12	3/12	
Max. Working Pressure	(kg/cm ²) / (psi)	16.4 / 233				
Testing Pressure	30 kg/cm ² for 1 min, leak test : 16 kg/cm ² for 5 min.					
Surface Area	m ² / ft ²	0.115 / 1.238	0.143 / 1.542	0.176 / 1.892	0.203 / 2.187	
Surface Air Velocity	(m/s) / (ft/min)	1.231 / 242.3	1.417 / 278.9	1.665 / 327.7	1.951 / 384.1	
MOTOR						
Type	Permanent split capacitor motor					
Power Supply	V/Ph/Hz	220 - 240 / 1 / 50 , 208 - 230 / 1 / 60				
Rated Input Power	W (50/60Hz)	71 / 72	102 / 114	148 / 172	180 / 223	
Rated Running Current	A (50/60Hz)	0.30 / 0.33	0.43 / 0.53	0.65 / 0.8	0.74 / 1.01	
Poles	4					
Sound Pressure Level (H/M/L)	dB(A)	33 / 30 / 26	37 / 34 / 29	38 / 36 / 34	40 / 39 / 36	
Control	Room Temp.	Micro-processor Controlled Thermostat				
	Operation	Wired micro-computer control				
Condensate Drain Size	mm	19.05				
AIR FILTER						
Washable Saranet Filter						
WEIGHT	kg	17	21	22	25	
DIMENSION (H x W x D)	mm	261X765X411	261X905X411	261X1,065X411	261X1,200X411	

Condition

Cooling capacity : Entering air temp. : 26.7°C (80°F)DB, 19.4C (67°F)WB
 Entering water temp. : 7.2°C (45°F)
 Leaving water temp. : 12.8°C (55°F)

Heating capacity : Entering air temp. : 21.1°C (64°F)DB
 Entering water temp. : 60°C (140°F)

Microphone position : 1.4 m below the centre of the unit. (GB standard - GB/D17758)
 Tested with 2m length duct at the air discharge outlet and air return inlet.

CEILING CONCEALED TYPE

MODEL		MCC		
		028CW	038CW	
PERFORMANCE				
Air Flow (CFM/CMH)	Super High	850 / 1,450	1,540 / 2,620	
	High	720 / 1,220	1,450 / 2,470	
	Medium	590 / 1,000	1,265 / 2,150	
	Low	500 / 850	1,070 / 1,820	
Nominal Total Cooling Capacity	kcal/hr	6,804	10,550	
	W	7,914	12,270	
	Btu/hr	27,000	41,864	
Sensible Cooling Capacity	kcal/hr	4,695	7,490	
	W	5,460	8,712	
	Btu/hr	18,630	29,723	
Nominal Total Heating Capacity (Entering water Temp. : 60°C)	kcal/hr	11,110	16,820	
	W	12,925	19,560	
	Btu/hr	44,100	66,750	
Water Flow Rate	USGPM / LITRES/M	5.36/20.26	8.31/31.41	
Differential Pressure Drop	Cooling	kPa	16.6	33.4
	Heating	kPa	13.8	27.9
COIL				
Type	Seamless copper tube mechanically boded to aluminium slit fin.			
Tube	OD 9.52 mm, thickness 0.35 mm.			
Fin	thickness 0.11 mm			
Connection	OD 3/4" copper tube			
Number of rows / fin per inch	3/18		3/14	
Max. Working Pressure	(kg/cm ²) / (psi)	16.4 / 233		
Testing Pressure	30 kg/cm ² for 1 min, leak test : 16 kg/cm ² for 5 min.			
Surface Area	m ² / ft ²	0.240 / 2.620	0.340 / 3.610	
Surface Air Velocity	(m/s) / (ft/min)	1.648 / 324.4	2.167 / 426.6	
MOTOR				
Type	Permanent split capacitor motor			
Power Supply	V/Ph/Hz	220 - 240 / 1 / 50		
Rated Input Power	W	300	563	
Rated Running Current	A	1.30	2.4	
Poles	4			
Sound Pressure Level (SH/H/M/L)	dBa	44 / 41 / 38 / 34	55 / 51 / 48 / 45	
Control	Room Temp.	Micro-computer Controlled Thermostat		
	Operation	Wired micro-computer control		
Condensate Drain Size	mm	19.05		
AIR FILTER				
Washable Saranet Filter				
WEIGHT	kg	38	41	
DIMENSION (H x W x D)	mm	290X942X600	310X1247X638	

Condition

Cooling capacity : Entering air temp. : 26.7 °C (80 °F) DB, 19.4 °C (67 °F) WB
 Entering water temp. : 7.2 °C (45 °F)
 Leaving water temp. : 12.8 °C (55 °F)

Heating capacity : Entering air temp. : 21.1 °C (64 °F) DB
 Entering water temp. : 60 °C (140 °F)

Microphone position : 1.4 m below the centre of the unit. (GB standard - GB/D17758)
 Tested with 2m length duct at the air discharge outlet and air return inlet.

CEILING CONCEALED TYPE

MODEL		MCC				
		030CW	040CW	050CW	060CW	
PERFORMANCE						
Air Flow (CFM/CMH)	Super High	1,000 / 1,700	1,300 / 2,210	1,550 / 2,640	1,800 / 3,060	
	High	950 / 1,610	1,150 / 1,960	1,500 / 2,550	1,700 / 2,900	
	Medium	900 / 1,530	1,100 / 1,870	1,480 / 2,510	1,650 / 2,800	
	Low	870 / 1,480	1,050 / 1,780	1,350 / 2,300	1,500 / 2,550	
Nominal Total Cooling Capacity	kcal/hr	7,308	9,576	12,348	13,608	
	W	8,500	11,138	14,362	15,827	
	Btu/hr	29,000	38,000	49,000	54,000	
Sensible Cooling Capacity	kcal/hr	5,189	6,799	8,644	9,798	
	W	6,035	7,908	10,053	11,396	
	Btu/hr	20,590	26,980	34,300	38,880	
Nominal Total Heating Capacity (Entering water Temp. : 60°C)	kcal/hr	11,390	14,820	18,800	21,720	
	W	13,245	17,230	21,860	25,260	
	Btu/hr	45,200	58,800	74,600	86,200	
Water Flow Rate	USGPM / LITRES/M	5.75 / 21.74	7.54 / 28.50	9.72 / 36.74	10.71 / 40.48	
Differential Pressure Drop	Cooling	kPa	10.7	18.8	34.7	6.5
	Heating	kPa	8.9	15.7	28.9	5.4
COIL						
Type	Seamless copper tube mechanically boded to aluminium slit fin.					
Tube	OD 9.52 mm, thickness 0.35 mm.					
Fin	thickness 0.11 mm					
Connection	OD 3/4" copper tube					
Number of rows / fin per inch		3/12	3/12	3/12	3/12	
Max. Working Pressure	(kg/cm ²) / (psi)	16.4 / 233				
Testing Pressure	30 kg/cm ² for 1 min, leak test : 16 kg/cm ² for 5 min.					
Surface Area	m ² / ft ²	0.270 / 2.980	0.310 / 3.440	0.400 / 4.400	0.470 / 5.160	
Surface Air Velocity	(m/s) / (ft/min)	1.705 / 335.6	1.920 / 377.9	1.790 / 352.3	1.772 / 348.8	
MOTOR						
Type	Permanent split capacitor motor					
Power Supply	V/Ph/Hz	220 - 240 / 1 / 50, 208 - 230 / 1 / 60				
Rated Input Power	W (50/60Hz)	421 / 486	550 / 661	670 / 767	748 / 804	
Rated Running Current	A (50/60Hz)	1.90 / 2.40	2.60 / 3.40	2.90 / 3.70	3.20 / 3.70	
Poles	4					
Sound Pressure Level (SH/H/M/L)	dBa	49 / 46 / 42 / 38	51 / 49 / 45 / 41	53 / 52 / 50 / 47	55 / 53 / 50 / 47	
Control	Room Temp.	Micro-computer Controlled Thermostat				
	Operation	Wired micro-computer control				
Condensate Drain Size	mm	19.05				
AIR FILTER						
Washable Saranet Filter						
WEIGHT	kg	39	42	54	62	
DIMENSION (H x W x D)	mm	378X929X474	378X1,045X474	378X1,299X474	378X1,499X474	

Condition

Cooling capacity : Entering air temp. : 26.7°C (80°F)DB, 19.4C (67°F)WB
 Entering water temp. : 7.2°C (45°F)
 Leaving water temp. : 12.8°C (55°F)

Heating capacity : Entering air temp. : 21.1°C (64°F)DB
 Entering water temp. : 60°C (140°F)

Microphone position : 1.4 m below the centre of the unit. (GB standard - GB/D17758)
 Tested with 2m length duct at the air discharge outlet and air return inlet.

DUCTED BLOWER SPLIT TYPE

MODEL		MDB				
		075BW	100BW	125BW	150BW	
PERFORMANCE						
Air Flow (CFM/CMH)		2,500 / 4,250	3,200 / 5,440	4,200 / 7,140	4,600 / 7,820	
Nominal Total Cooling Capacity	kcal/hr	19,152	24,696	32,760	41,076	
	W	22,274	28,722	38,101	47,773	
	Btu/hr	76,000	98,000	130,000	163,000	
Sensible Cooling Capacity	kcal/hr	13,598	18,028	23,587	29,164	
	W	15,810	20,961	27,425	33,909	
	Btu/hr	53,960	71,540	93,600	115,730	
Nominal Total Heating capacity (Entering water Temp. : 60 °C)	kcal/hr	31,250	40,070	52,670	65,520	
	W	36,340	46,600	61,240	76,180	
	Btu/hr	124,000	159,000	209,000	260,000	
Water Flow Rate		USGPM / LITRES/M	15.08 / 57.00	19.44 / 73.48	25.79 / 97.49	32.34 / 122.24
Differential Pressure Drop	Cooling	kPa	49.6	14.9	20.2	15.9
	Heating	kPa	41.4	12.4	16.8	13.2
COIL						
Type		Seamless copper tube mechanically bonded to aluminium slit fin.				
Tube		OD 9.52 mm, thickness 0.35 mm.				
Fin		thickness 0.11 mm				
Connection		OD 1 1/8" copper tube				
Number of rows / fin per inch		3/14	4/12	3/14	4/14	
Max. Working Pressure		(kg/cm ²)/(psi)	16.4 / 233			
Testing Pressure		30 kg/cm ² for 1 min, leak test : 16 kg/cm ² for 5 min.				
Surface Area		m ² /ft ²	0.54 / 5.82	0.54 / 5.82	1.01 / 10.83	1.01 / 10.83
Surface Air Velocity		(m/s)/(ft/min)	2.15 / 430	2.75 / 550	1.94 / 388	2.12 / 425
MOTOR						
Type		Permanent split capacitor motor with sleeve bearing				
Power Supply		V/Ph/Hz	220 - 240 / 1 / 50 , 208-230 / 1 / 60	415 / 3 / 50 , 415 / 3 / 60		
Rated Input Power		W (50/60Hz)	810 / 1062	1008 / 1310	2730 / 1620	3370 / 1999
Rated Running Current		A (50/60Hz)	3.70 / 5.16	4.22 / 7.04	3.39 / 5.70	3.39 / 5.70
Poles		4				
Number of motors		2	2	1	1	
Sound pressure level		dBA	58	59	57	50
Control		-				
Condensate Drain Size		mm	25.4			
FAN						
Type/Drive		Centrifugal fan (forward-curved) / Direct		Centrifugal fan (forward-curved) / Belt driven		
Number of Fans		2	2	1	1	
AIR FILTER (OPTIONAL)						
Type		Washable Saranet Filter				
Length x Height		mm	622 x 433			
Quantity		2	2	1	1	
WEIGHT		kg	96	100	140	145
DIMENSION (HxWxD)		mm	572 x 1,502 x 761		885 x 1,640 x 1,040	

Condition

Cooling capacity : Entering air temp. : 26.7°C (80°F)DB, 19.4C (67°F)WB
 Entering water temp. : 7.2°C (45°F)
 Leaving water temp. : 12.8°C (55°F)

Heating capacity : Entering air temp. : 21.1°C (64°F)DB
 Entering water temp. : 60°C (140°F)

Microphone position : MDB 075BW / 100BW / 125BW -- 1.5m from unit air return opening / duct discharge opening (duct length = 10ft)
 MDB 150BW -- 1.5m below the unit, discharge air is ducted to adjacent room, free return.

Unit Selection Procedure

The cooling and heating capacities of the fan coil units can be determined by the Cooling Capacity Performance Chart and Heating Capacity Performance Chart in the following pages based on nominal air flow at standard water temperature. The total and sensible capacities must be adjusted as variables come in. A sample of selection procedure is given as below:

Step 1

Determine type of fan coil units to be used, i.e. ceiling cassette (MCK-AW Series); ceiling exposed (MCM-DW Series); etc.

Step 2

Select a tentative unit size based on cooling capacities at nominal air flow. Design entering air temperatures and required water flows from cooling capacities chart (Page 14 - 47) or the nominal capacities ratings (Page 3 - 10) from standard specification.

Step 3

Determine the nominal unit cooling capacities for the unit selected. If the cooling capacities chart must be used, the following information must be known :-

- a) Design water temperature rise
- b) Design entering water temperature
- c) Design entering air dry bulb temperature
- d) Design entering air wet bulb temperature

Example of how to read the cooling performance chart.

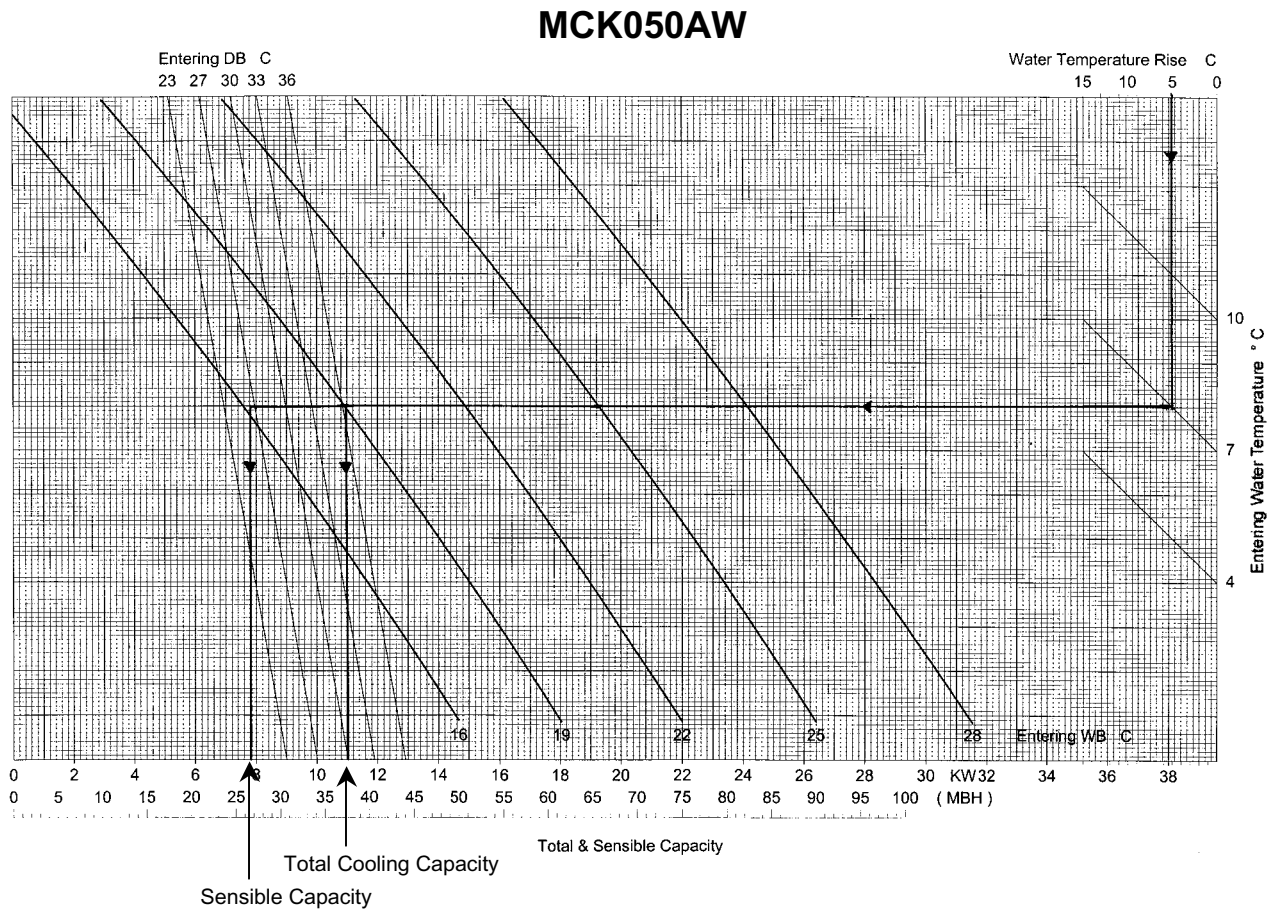

Step 4

If air flow value is different from the nominal value (high speed), then refer to specification from Page 3 to 10 for the air flow required (medium or low speed). Determine the total and sensible correction factor from Air Flow Capacity Correction Factor (Page 71).

Step 5

If the unit is to operate at an altitude above sea level, multiply the capacity correction factors by an Altitude Correction Factors. Refer to Page 71.

Step 6

Calculate the actual cooling capacity by multiply the nominal capacity (from Step 3) with Air Flow Capacity Correction Factor from Step 4 and the Altitude Correction Factor from Step 5.

$$\text{Actual Capacity, W} = \text{Nominal capacity (Step 3)} \times \text{Air Flow Capacity Correction Factor (Step 4)} \times \text{Altitude Correction Factor (Step 5)}$$

Step 7

Water flow rate can be determined by:

$$\text{Litres/Min} = \frac{\text{Total Cooling Capacity, W}}{70 \times \text{Water Temperature Rise } ^\circ\text{C}}$$

$$\text{USGPM} = \frac{\text{Total Cooling Capacity, Btu/H}}{500 \times \text{Water Temperature Rise } ^\circ\text{F}}$$

Step 8

Heating Capacities at nominal air flow (Page 48 to 65 - Heating Performance Chart) are based on standard condition of 60°C EWT and 21°C EAT. The actual heating capacity can be obtained by using the Heating Capacity Correction Factor (Page 71) and Altitude Correction Factor as per Step 5.

$$\text{Hence Actual Heating Capacity, W} = \text{Nominal Capacity (Page 48 to 65)} \times \text{Heating Capacity Correction Factor (Page 71)} \times \text{Air Flow Capacity Correction Factor (Step 4)} \times \text{Altitude Correction Factor (Step 5)}$$

Step 9

Water Pressure Drop Tables are on Page 66 to 70.

EXAMPLE

Select a ceiling cassette type fan coil unit at the following design specification:

Room design condition	: 26.7°C DB / 19°C WB
Room Cooling Load	: 7 kW sensible capacity / 10 kW total capacity
Room Heating Load	: 10 kW
Entering water temperature	: 7°C cooling / 54°C heating
Water temperature rise	: 5°C
Air Volume	: 1700 cmh
Altitude	: 600 m

SOLUTION**Step 1**

Based on the type of fan coil required and the design conditions, tentatively select MCK050AW. From the cooling capacity performance chart (Page 24), at 26.7°C DB / 19°C WB air temperature, 7°C entering water temperature and with 5°C water temperature rise, the cooling capacity for this unit is 11 kW total capacity and 7.8 kW sensible capacity.

Step 2

From page 71, the air flow correction factor table, at high speed, the air volume is 1840 cmh and medium speed is 1680 cmh, hence high speed is selected. And the correction factor is hence 1.0.

If lower air flow required, then use the medium and low fan speed. The correction factor can be determined by getting the ratio of air flow (i.e. medium or low speed / high speed).

Step 3

As the unit is operating at 600m above sea level, the Altitude correction factor is 0.98 total and 0.93 sensible.

Step 4

Multiply the cooling capacities obtained from step 1 (as per specification and design condition) by correction factors from (2) and (3)

$$\text{Actual total cooling capacity} = 11 \times 1.0 \times 0.98 \text{ kW} = 10.78 \text{ kW}$$

$$\text{Actual sensible cooling capacity} = 7.8 \times 1.0 \times 0.93 \text{ kW} = 7.250 \text{ kW}$$

Step 5

$$\text{Water flow rate} = \text{Litres/M} = \frac{10780 \text{ W}}{70 \times 5} = 30.8$$

Step 6

From Heating Capacity Performance Chart (Page 53), determine the heating capacity at the nominal air volume by using the flow rate calculated in step 5. The heating capacity is at 16.22 kW.

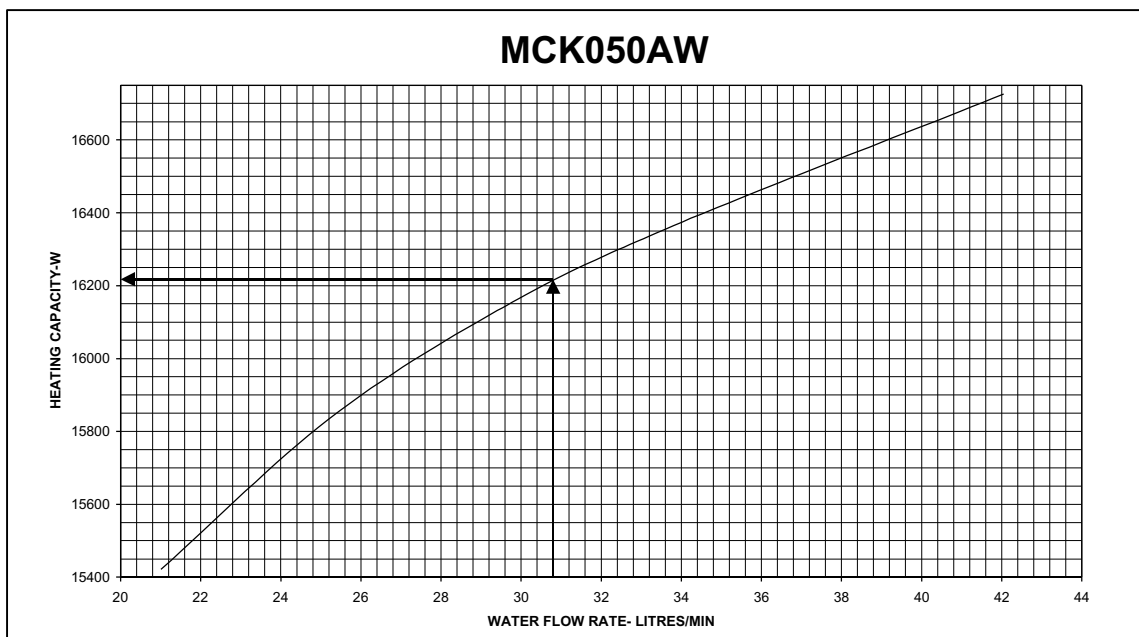
**Step 7**

From Heating Capacity Correction Factor Tables at 54.4°C water entering temperature and 26.7°C entering air temperature, the correction factor is 0.717,

$$\text{Actual Heating Capacity} = 16.22 \times 0.98 \times 0.717 = 11.40 \text{ kW}$$

Step 8

Water Pressure Drop can be estimated from water Pressure Drop Table (Page 66 to 70) using interpolate method:

At flow rate of 30.8 Litres/Min, the nominal pressure drop is 35,695 Pa

$$\text{Pressure drop correction factor} = 1.2947 - 0.0021 \times (\text{EWT}^\circ\text{C} \times 1.8 + 32) = 1.0234$$

Hence the actual pressure drop = nominal pressure drop x correction factor = 36,530 Pa.

Cooling Capacity Performance Chart

MWWM005FW

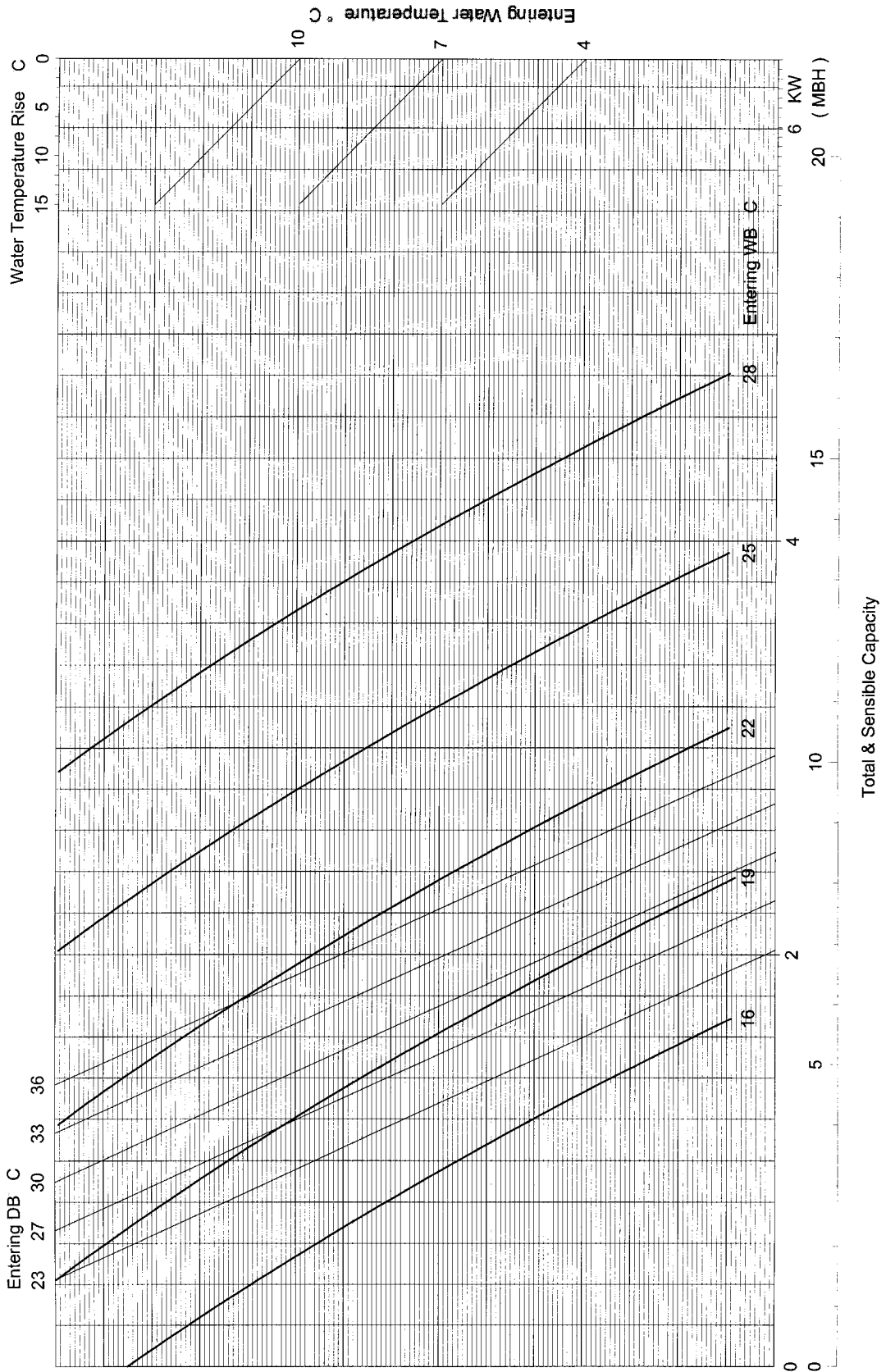

MWVM007FW

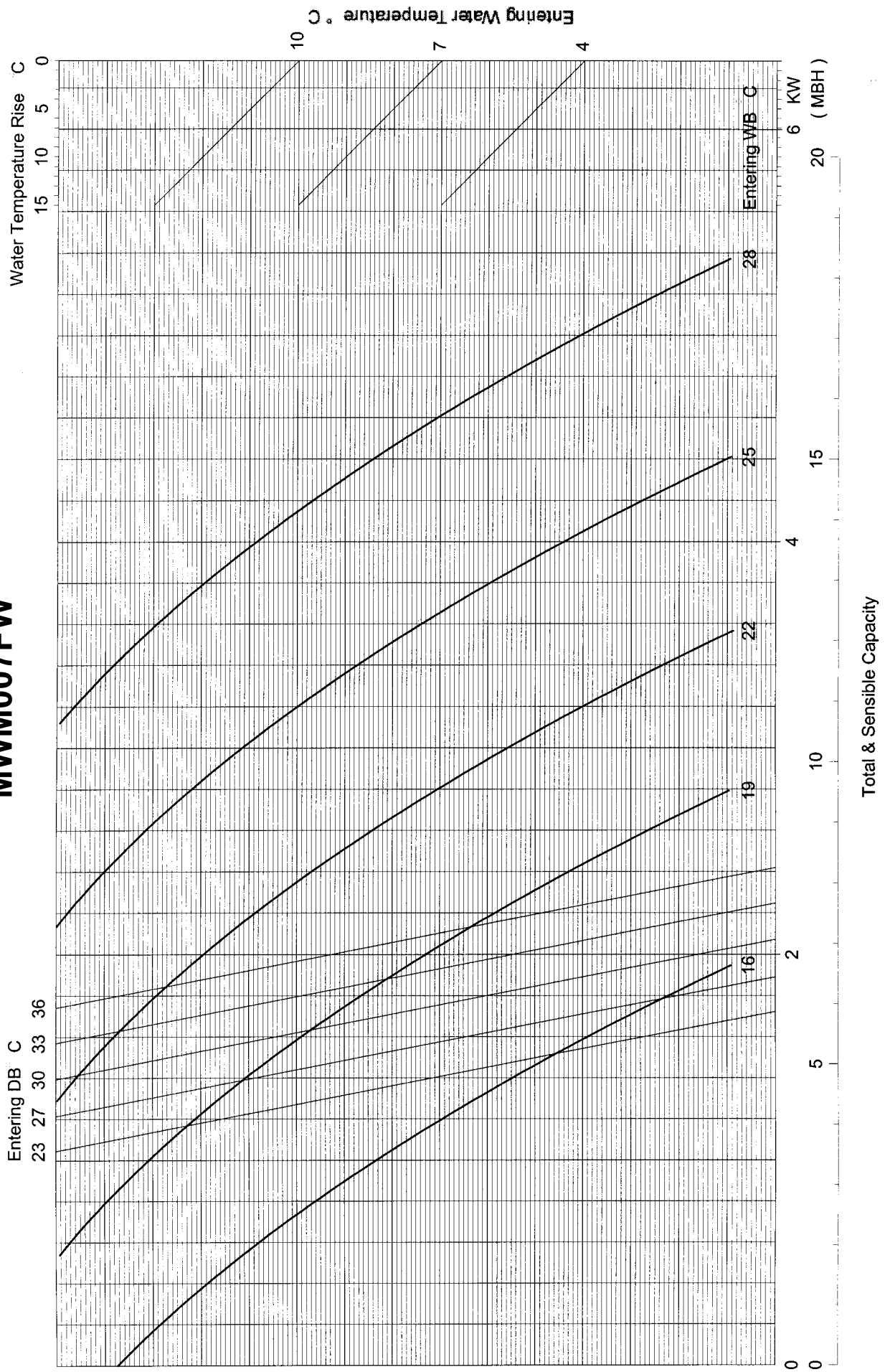

MWVM010FW

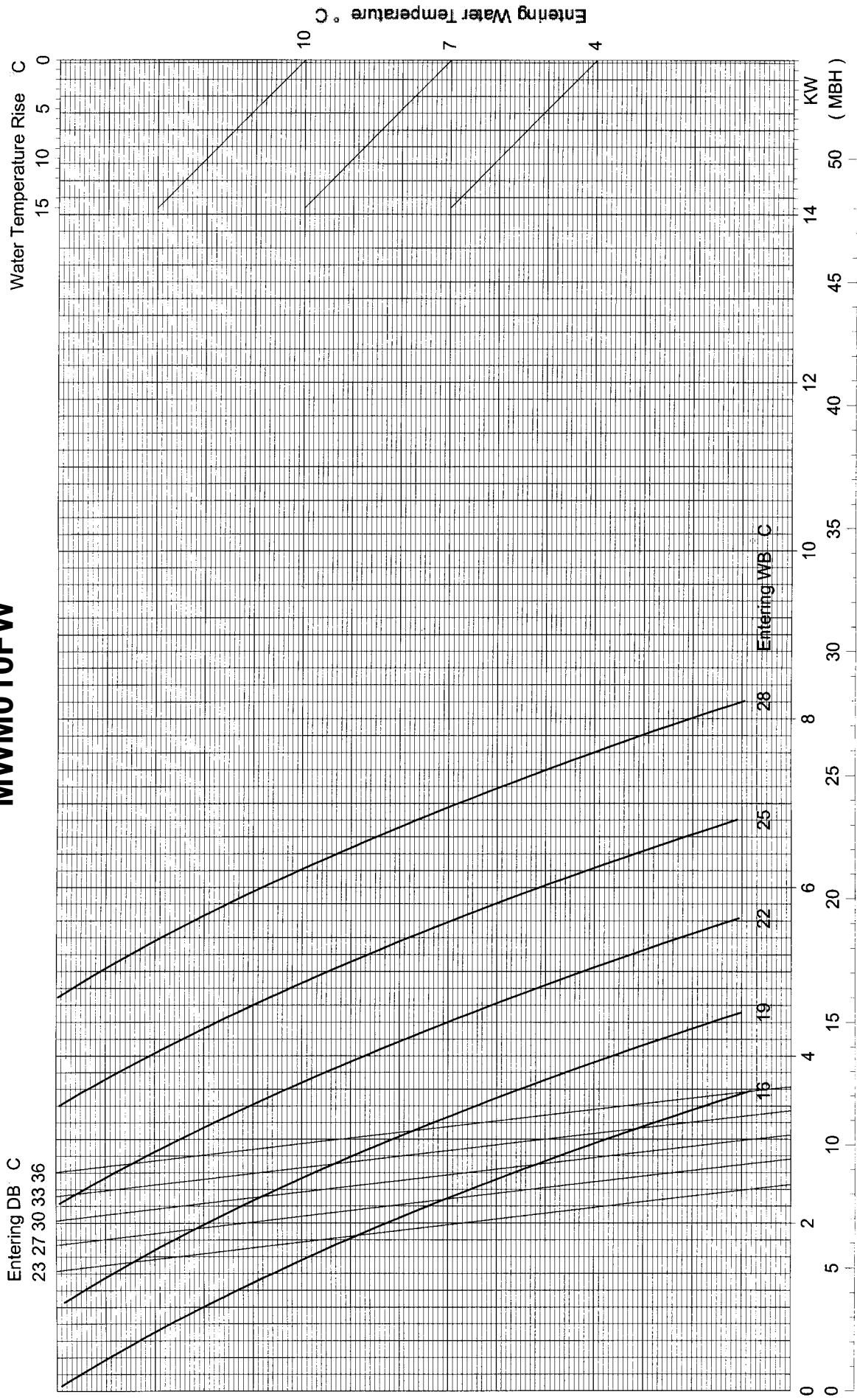

Total & Sensible Capacity

MWWM015FW

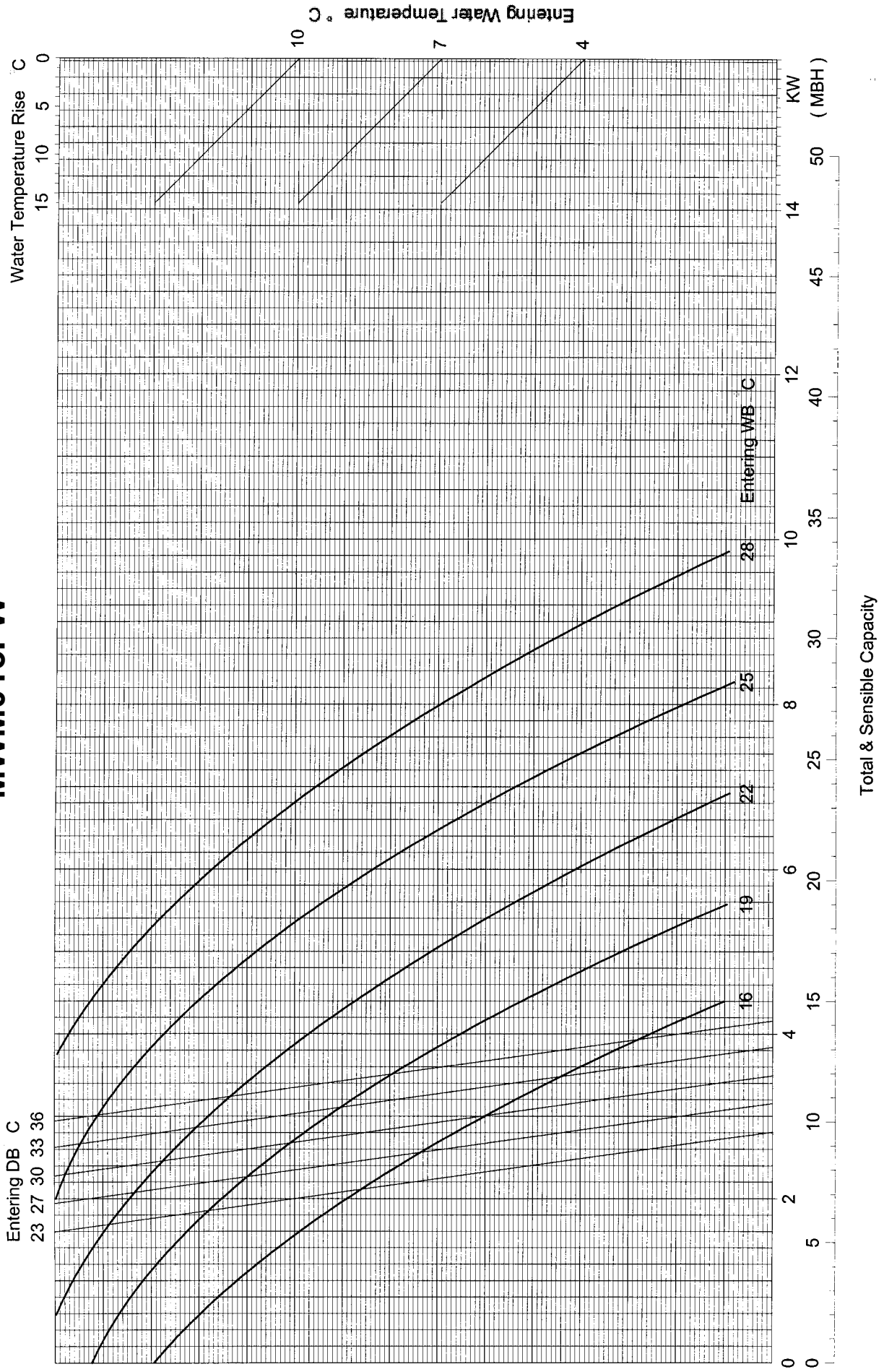

MWVM020FW

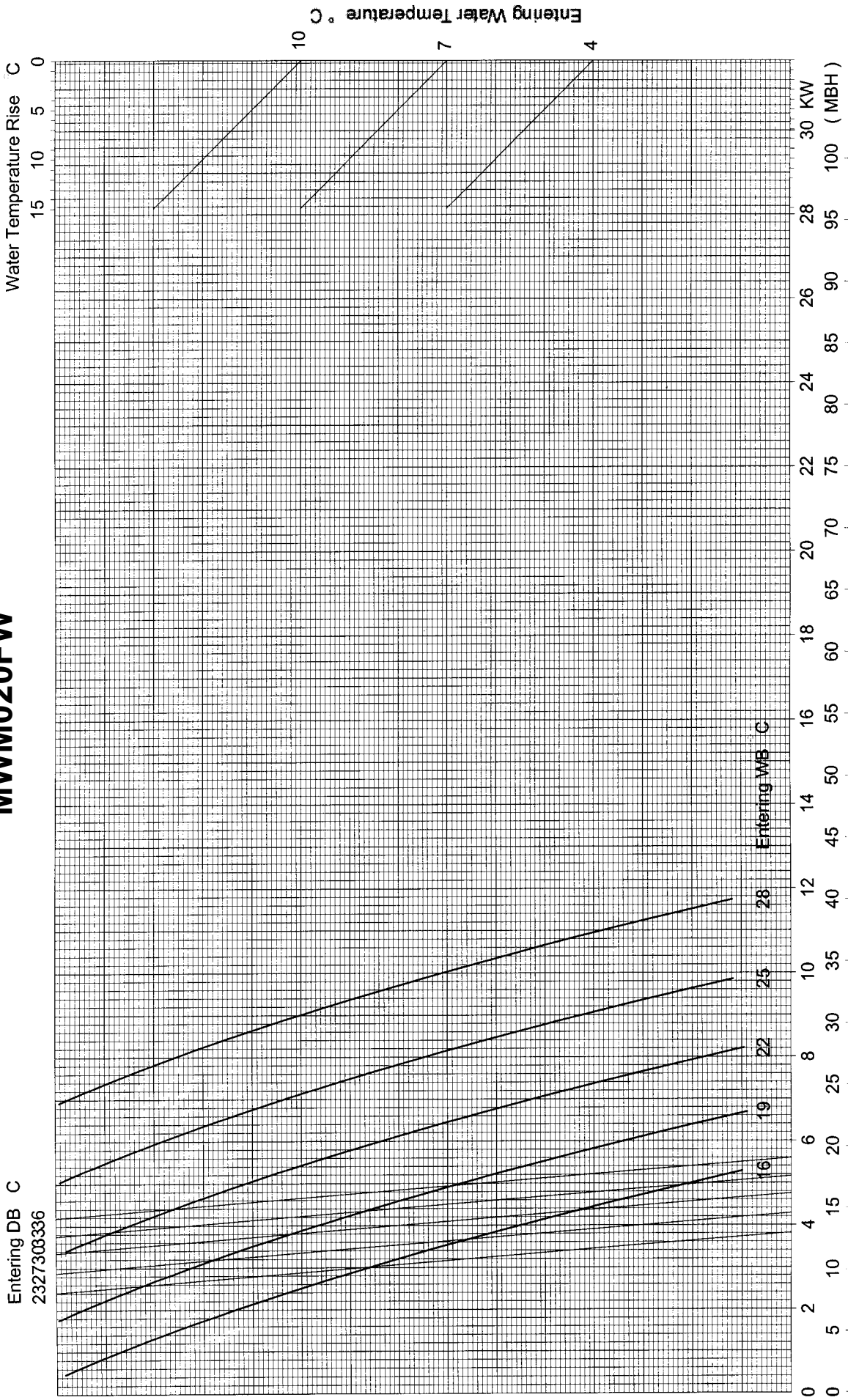

Total & Sensible Capacity

MWWM025FW

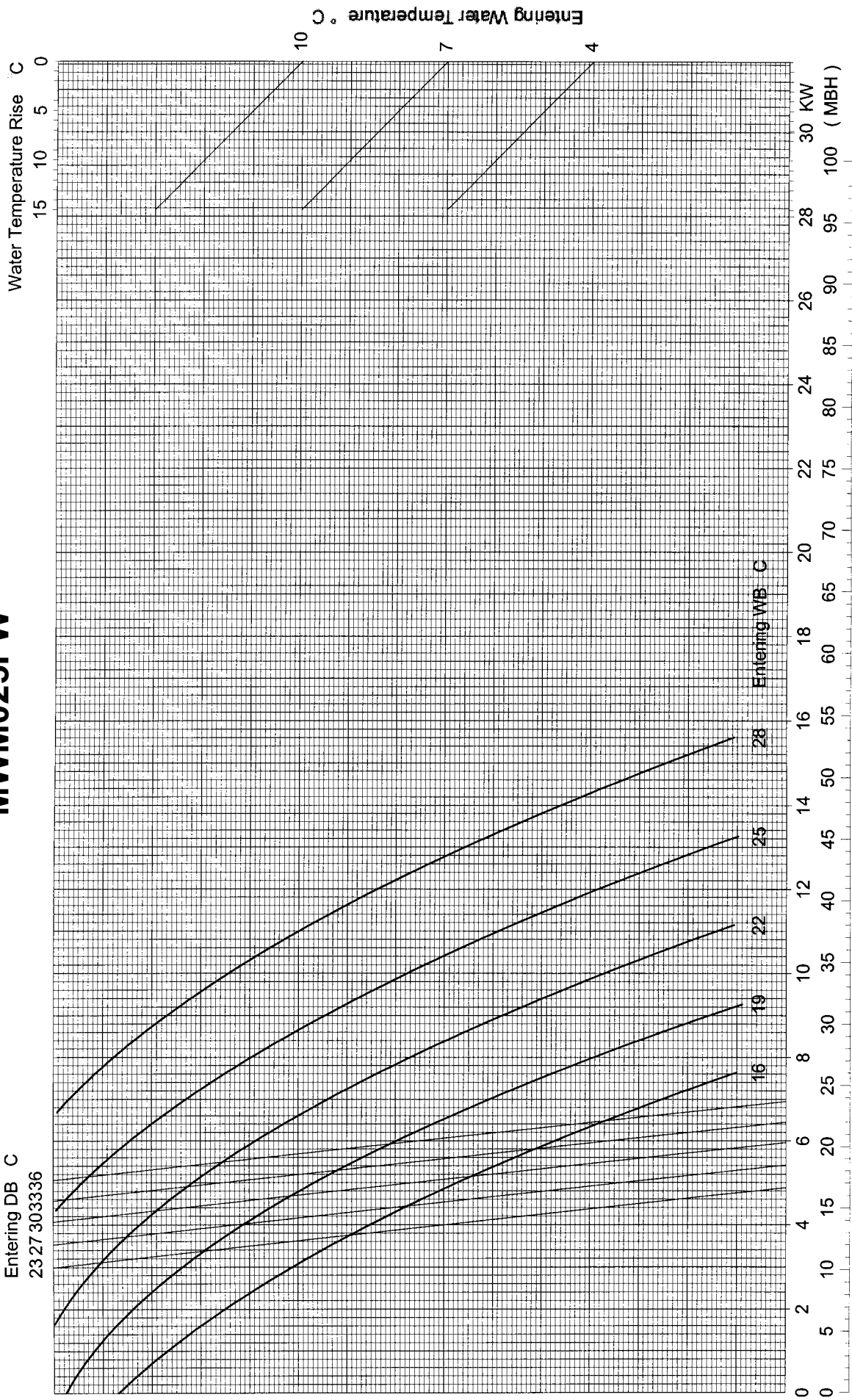

MCK020AW

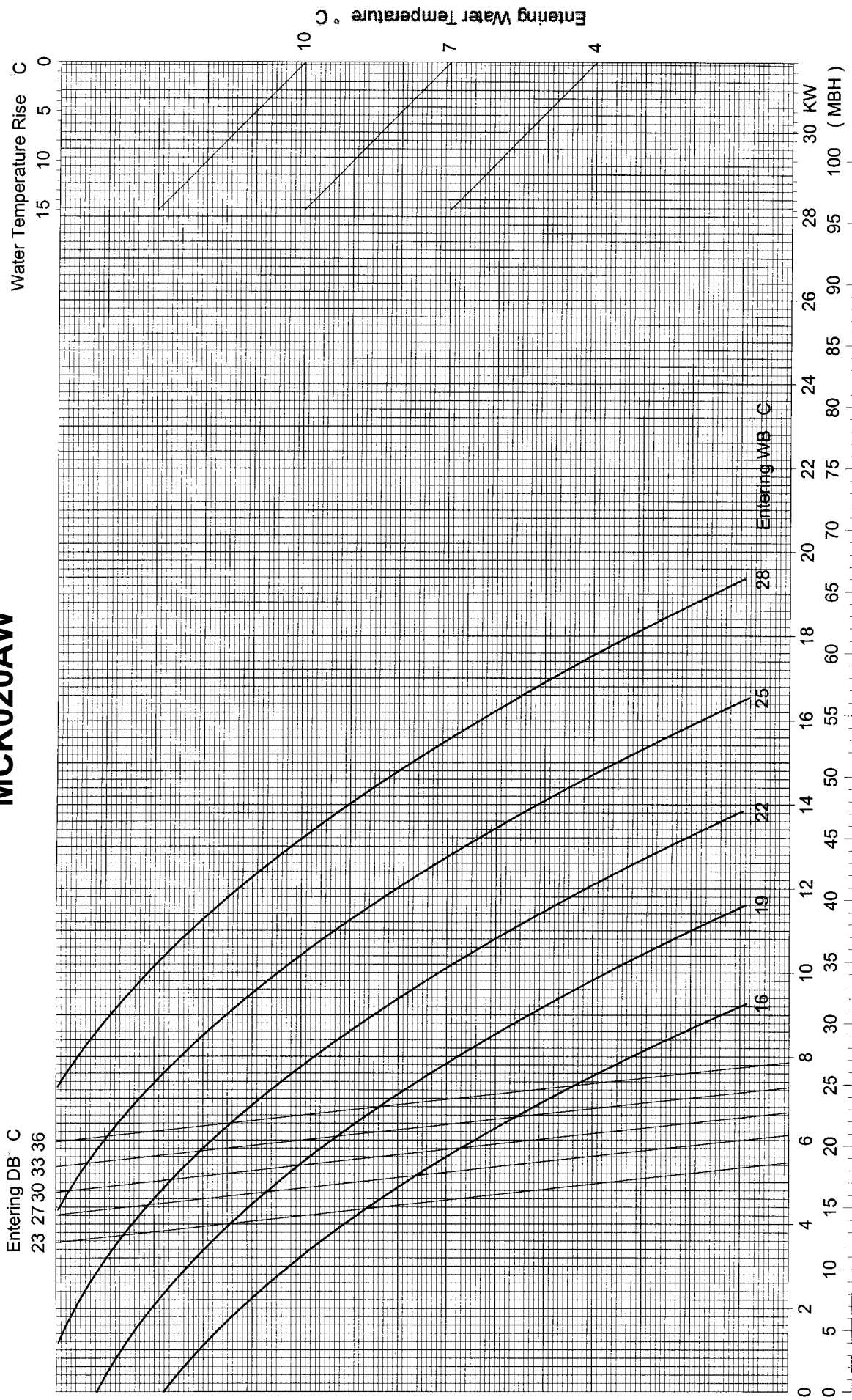

MCK025AW

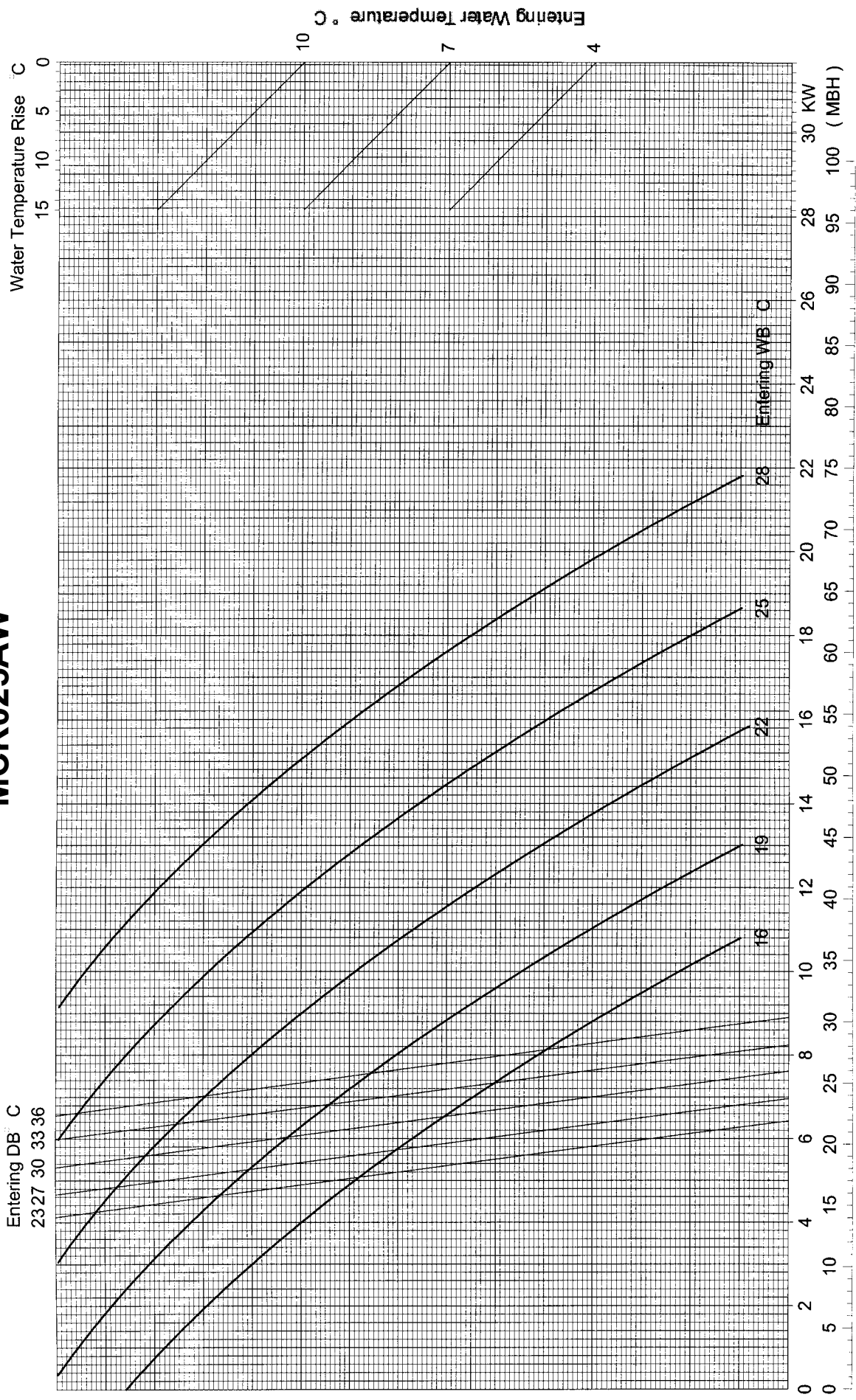

Total & Sensible Capacity

MCK030AW

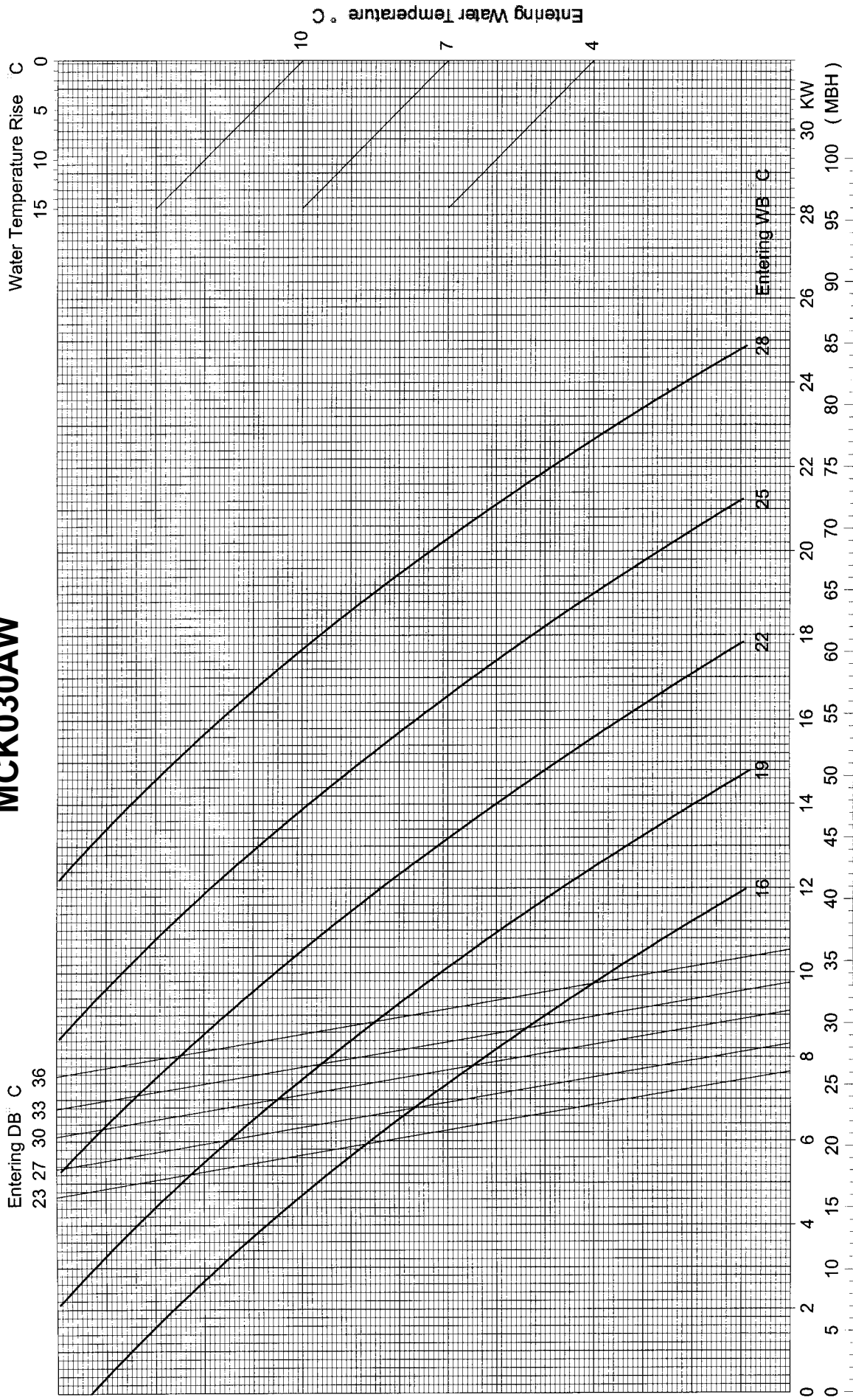

MCK040AW

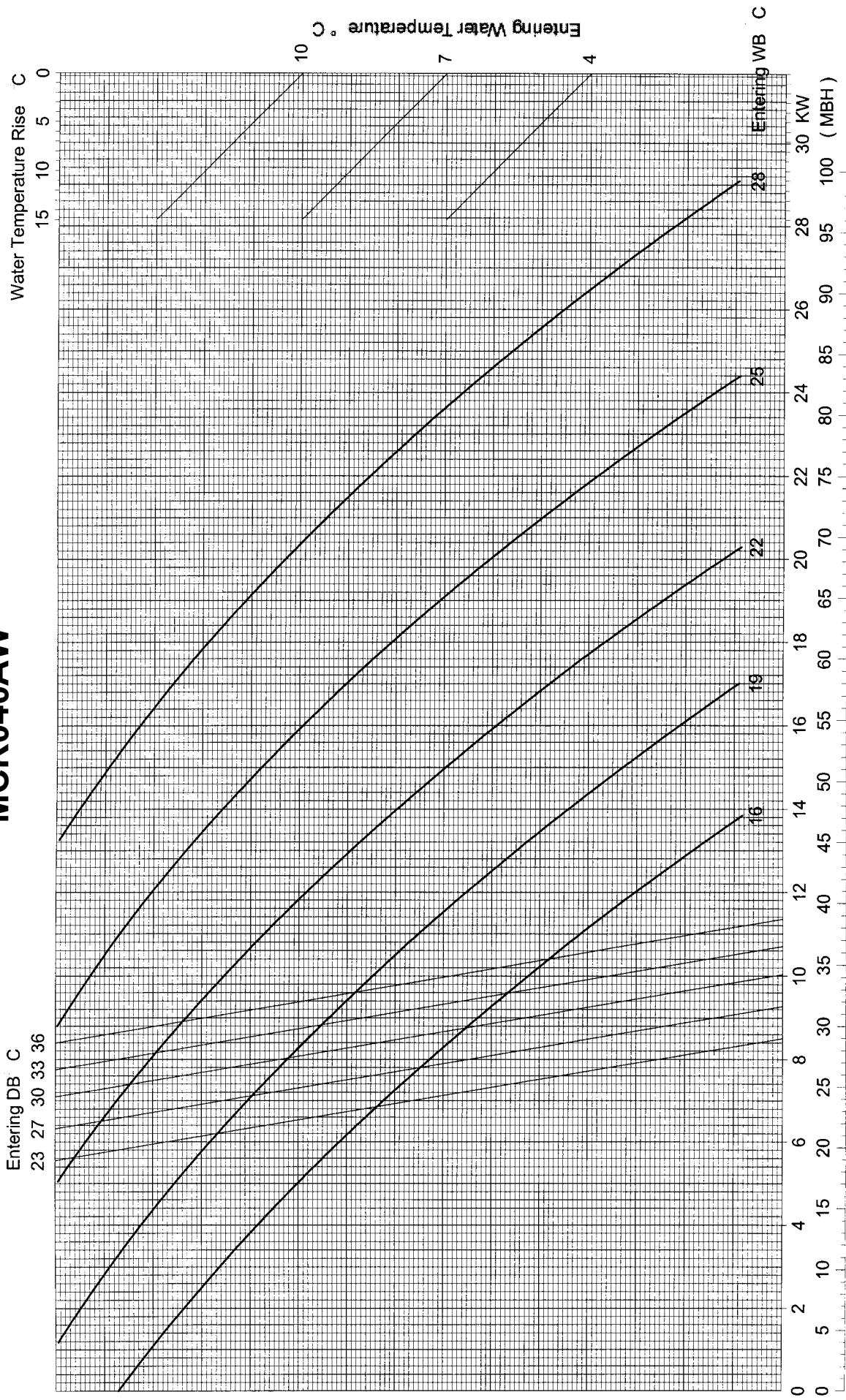

MCK050AW

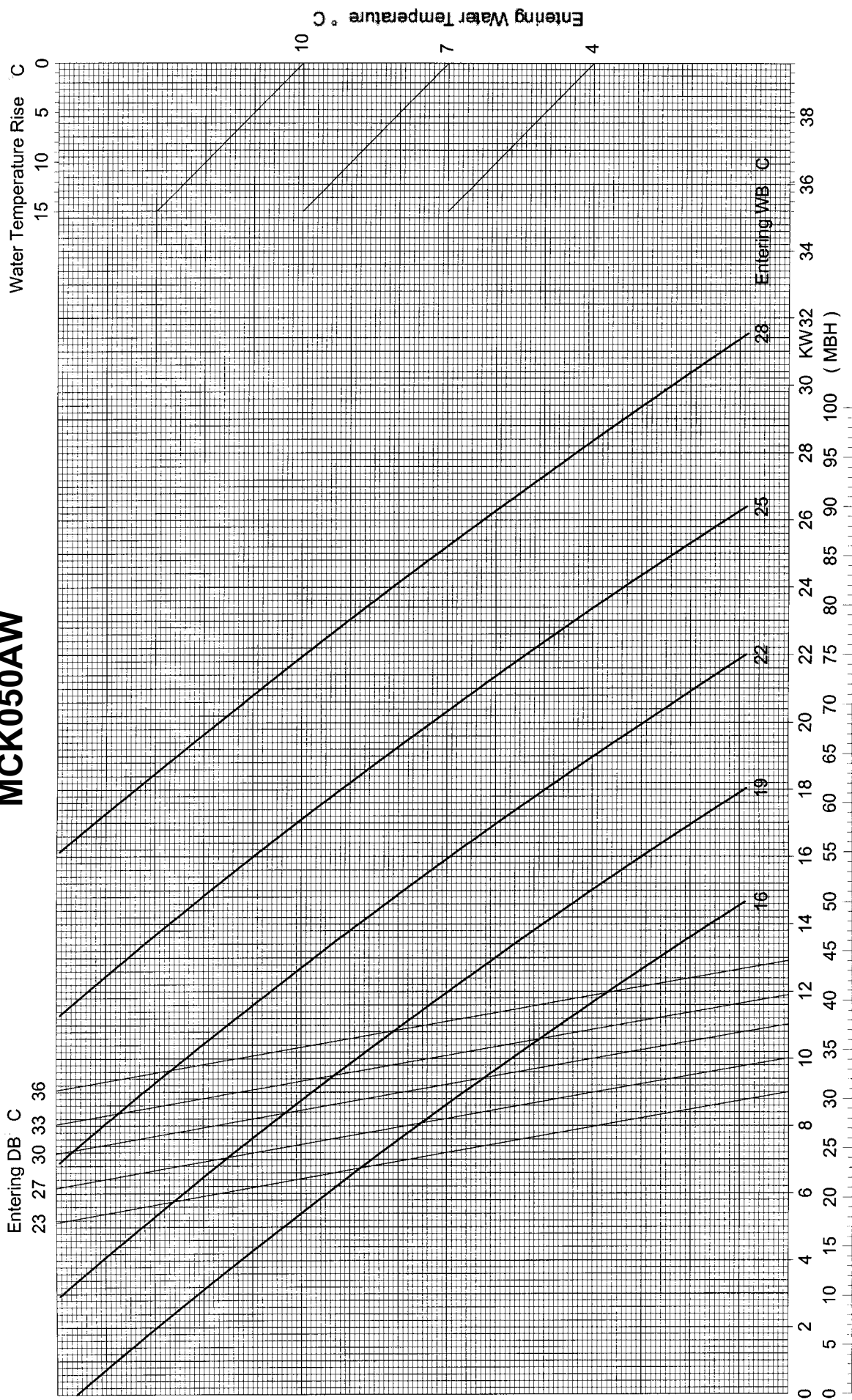

Total & Sensible Capacity

MCK015BW

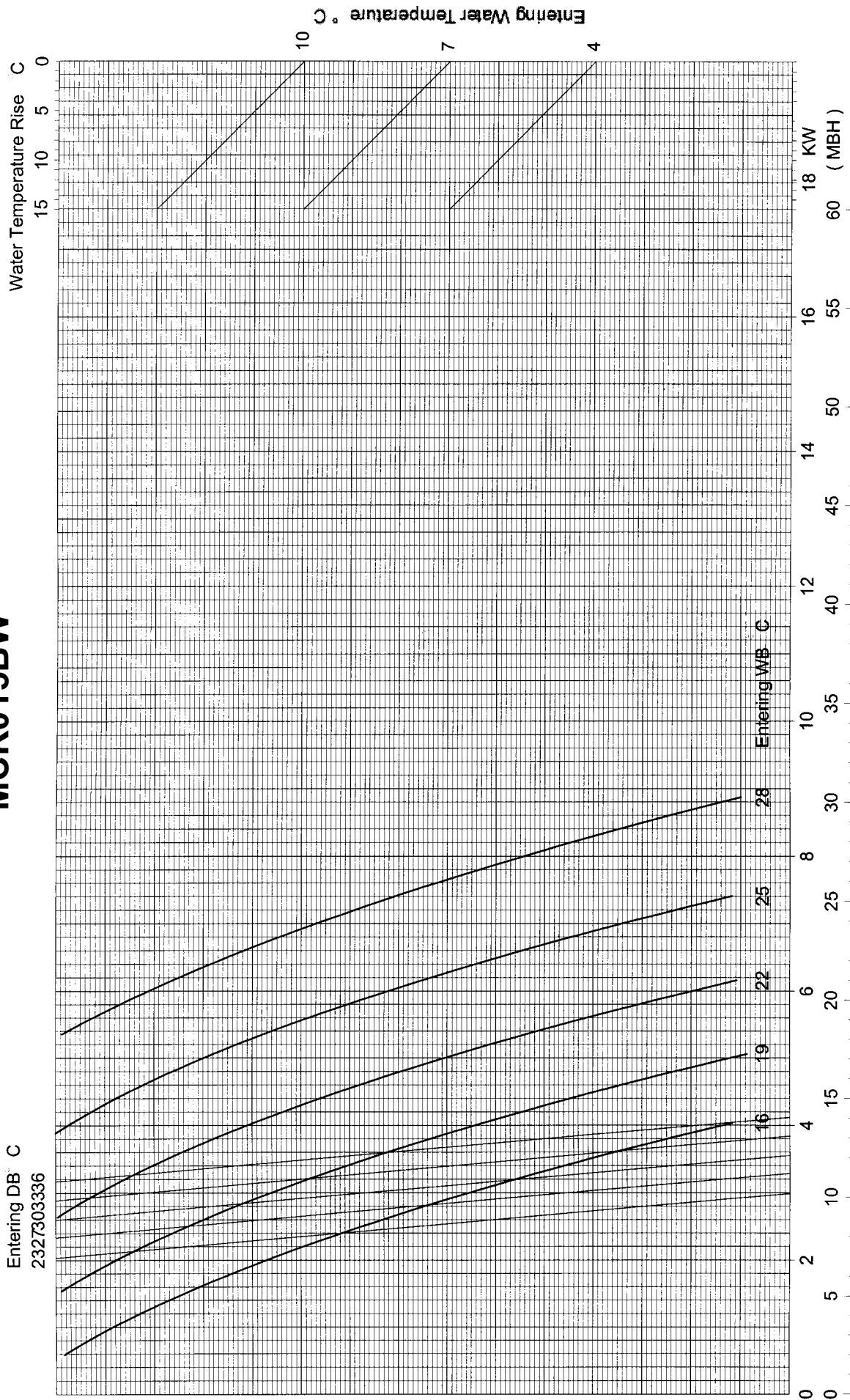

Entering DB C
2327303336

Entering WB C

Total & Sensible Capacity

MCK020BW

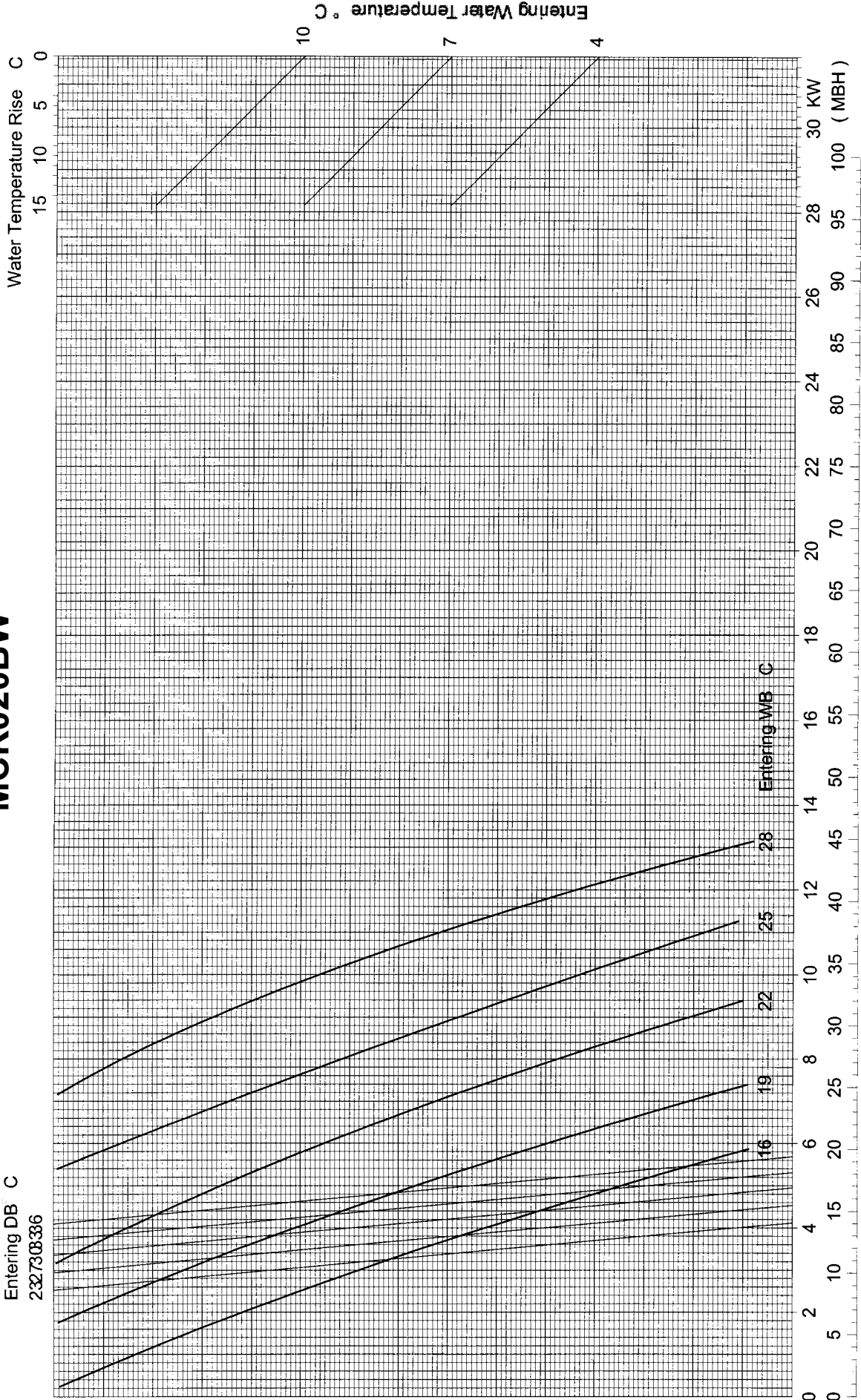

MCK025BW

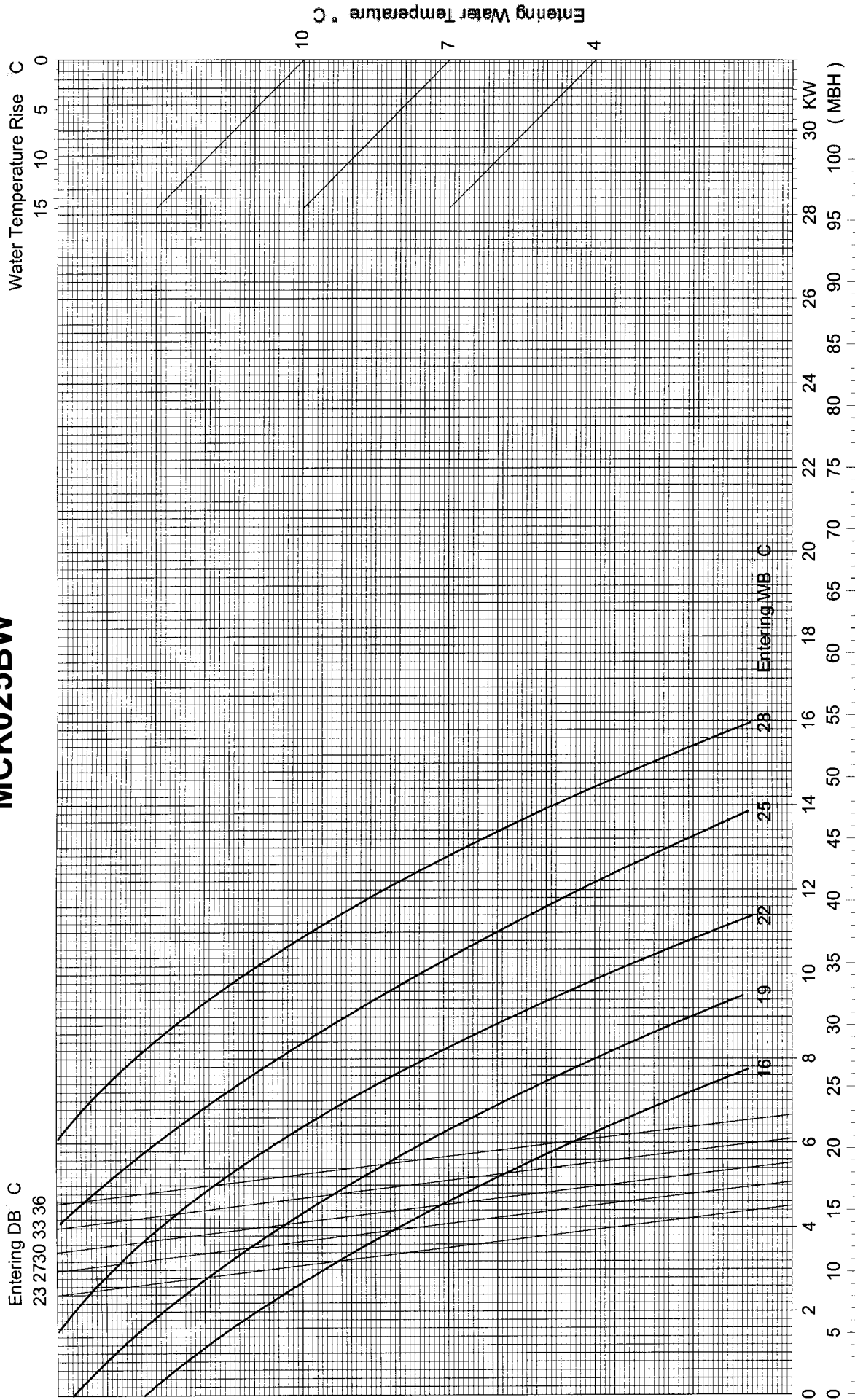

MCK030BW

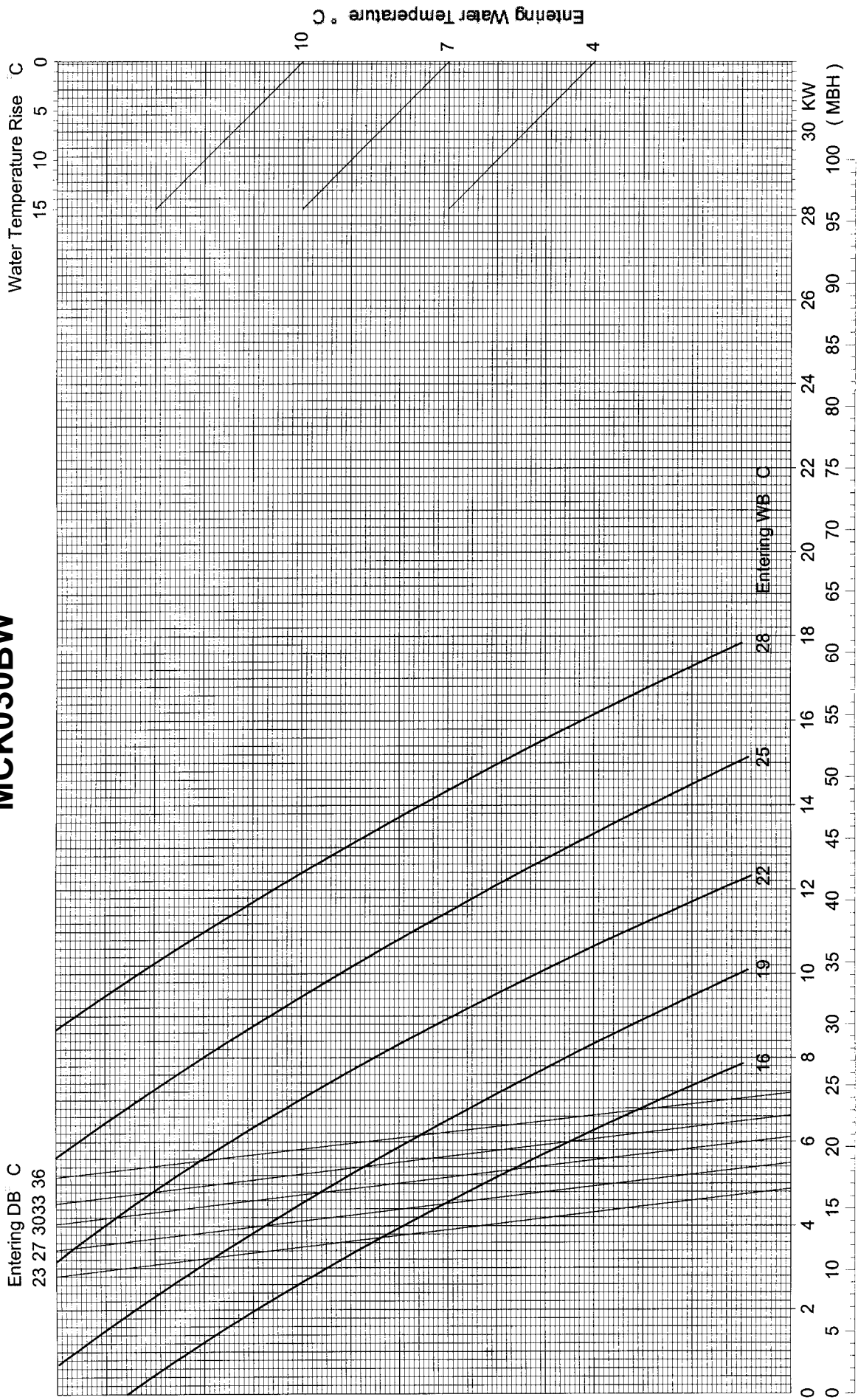

MCM020DW

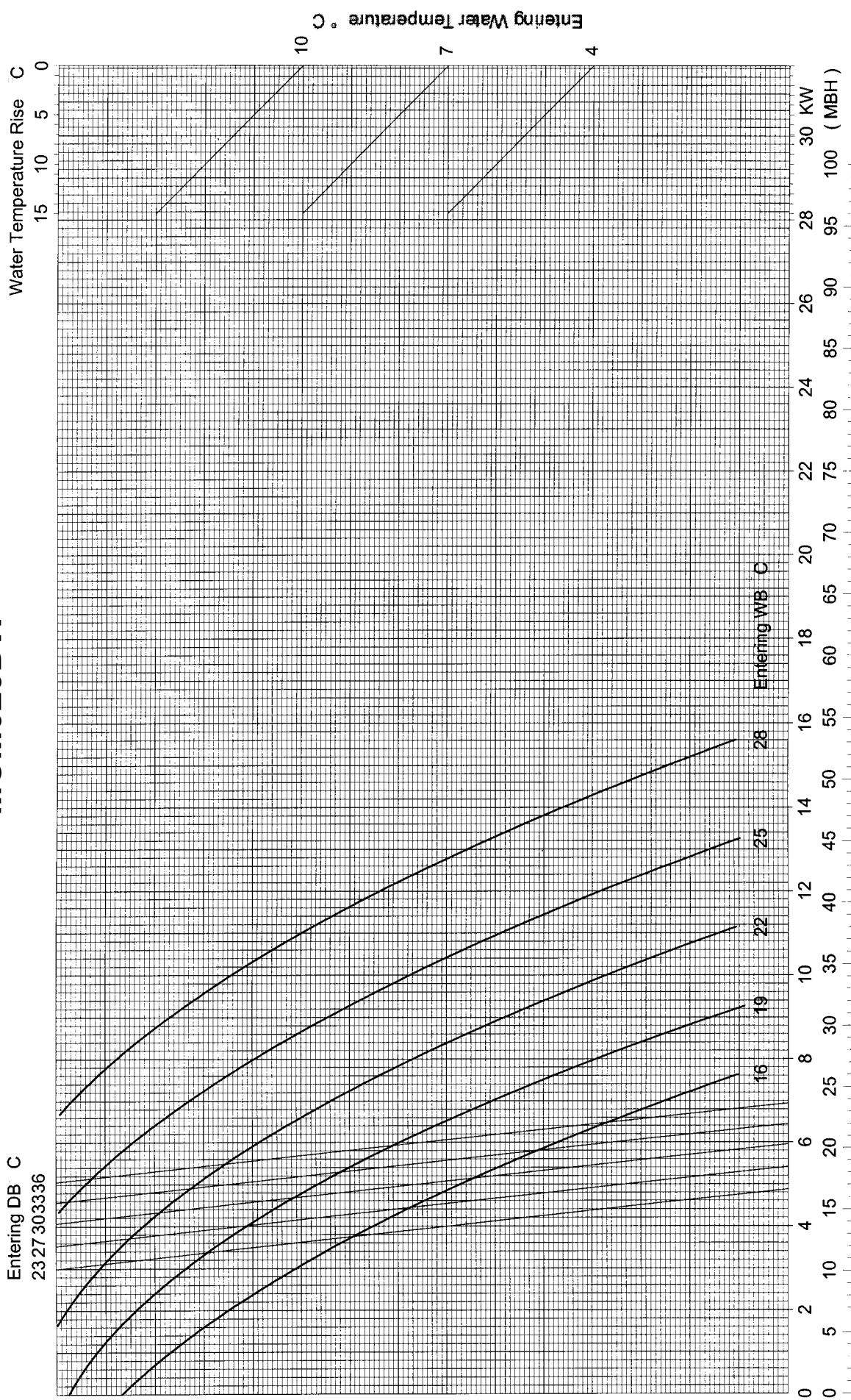

MCM025DW

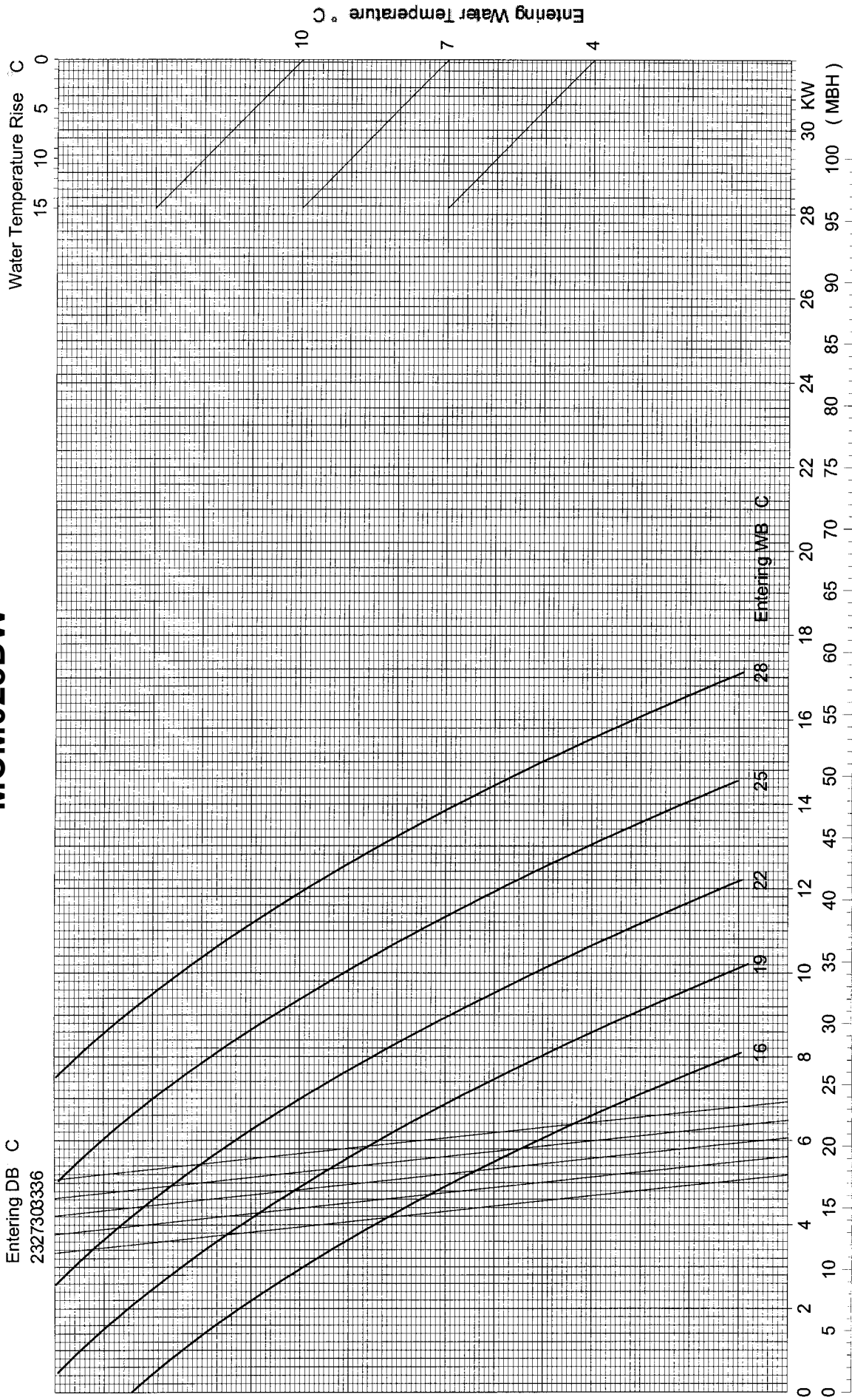

MCM030DW

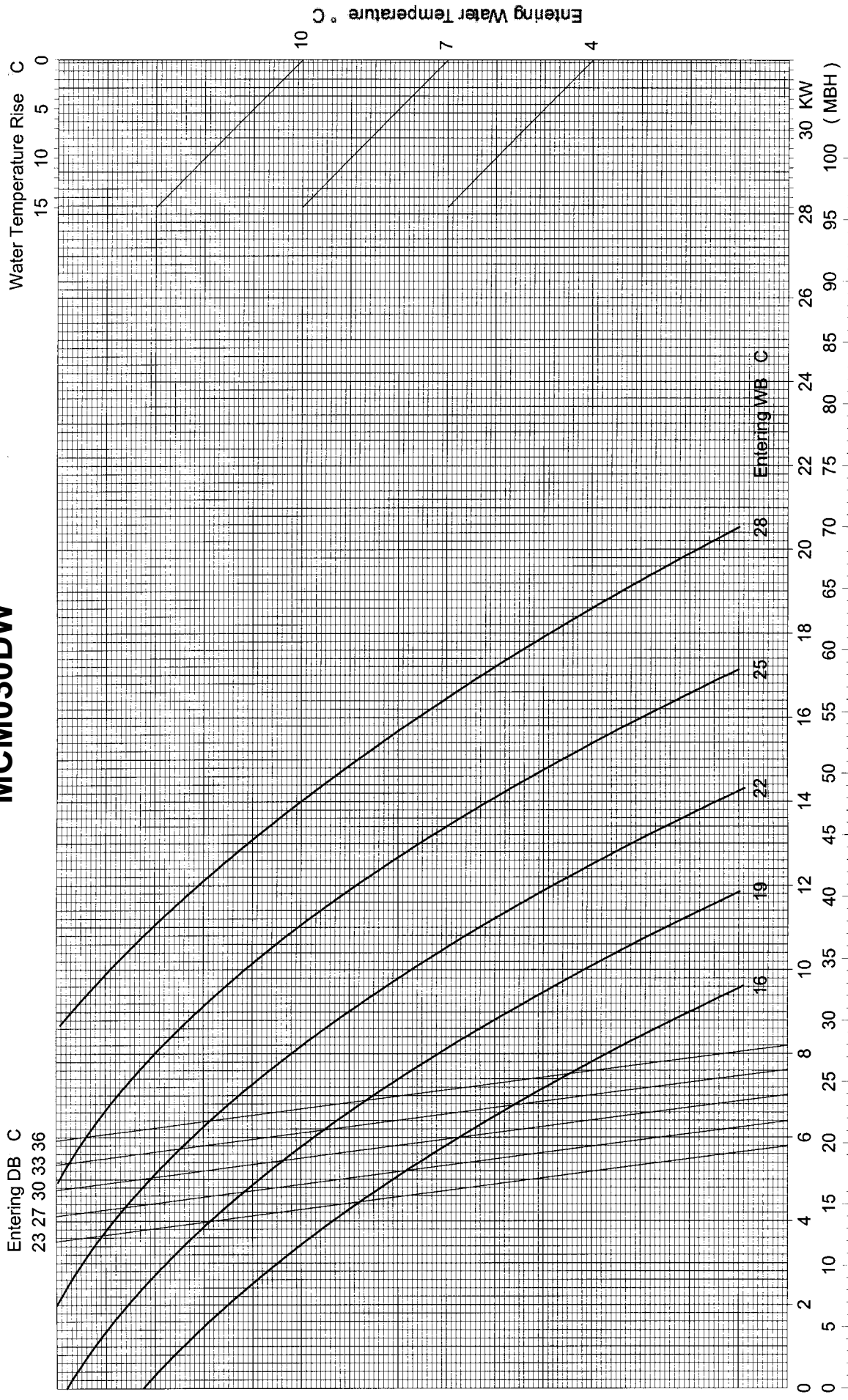

Total & Sensible Capacity

MCM040DW

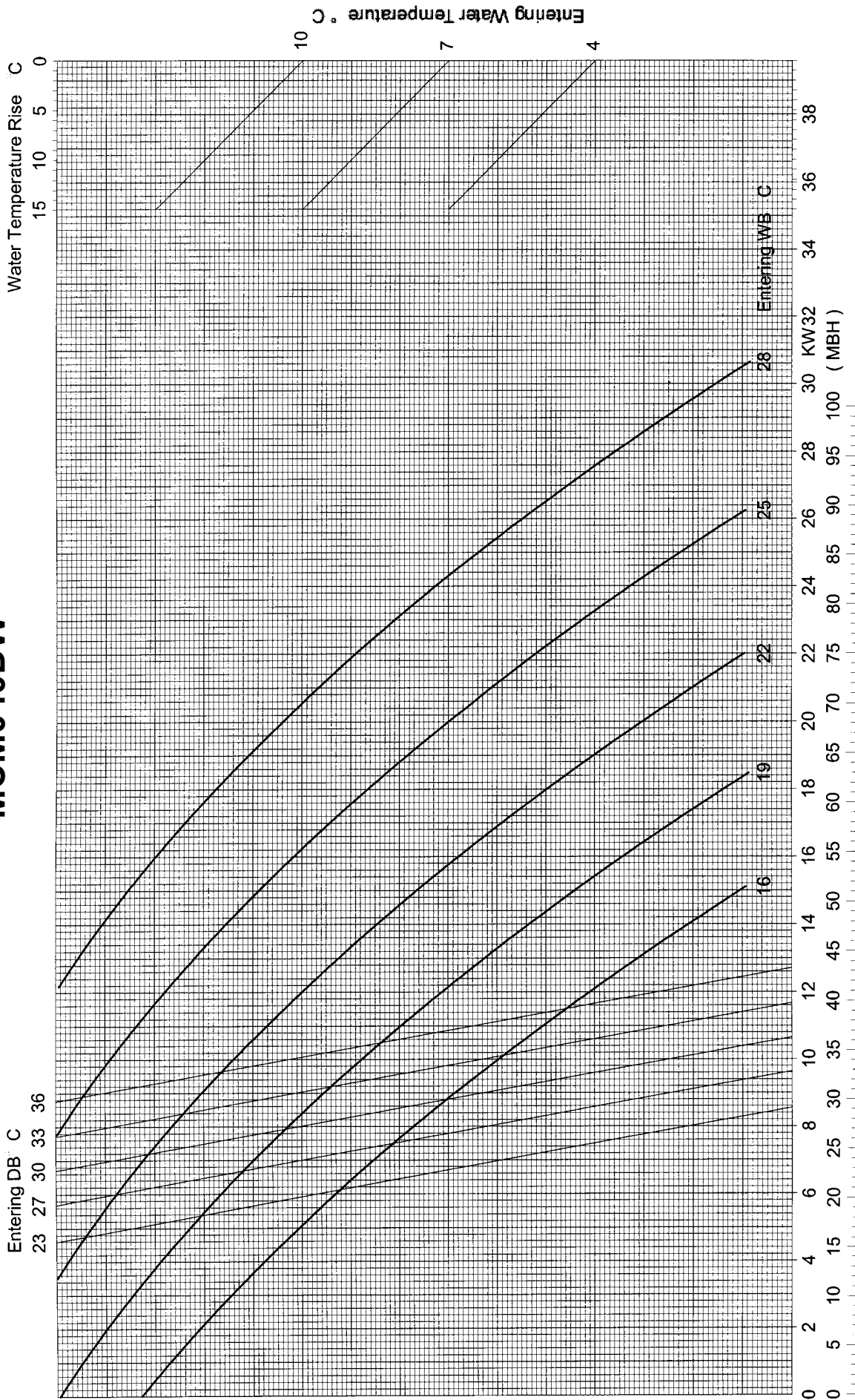

Total & Sensible Capacity

MCM050DW

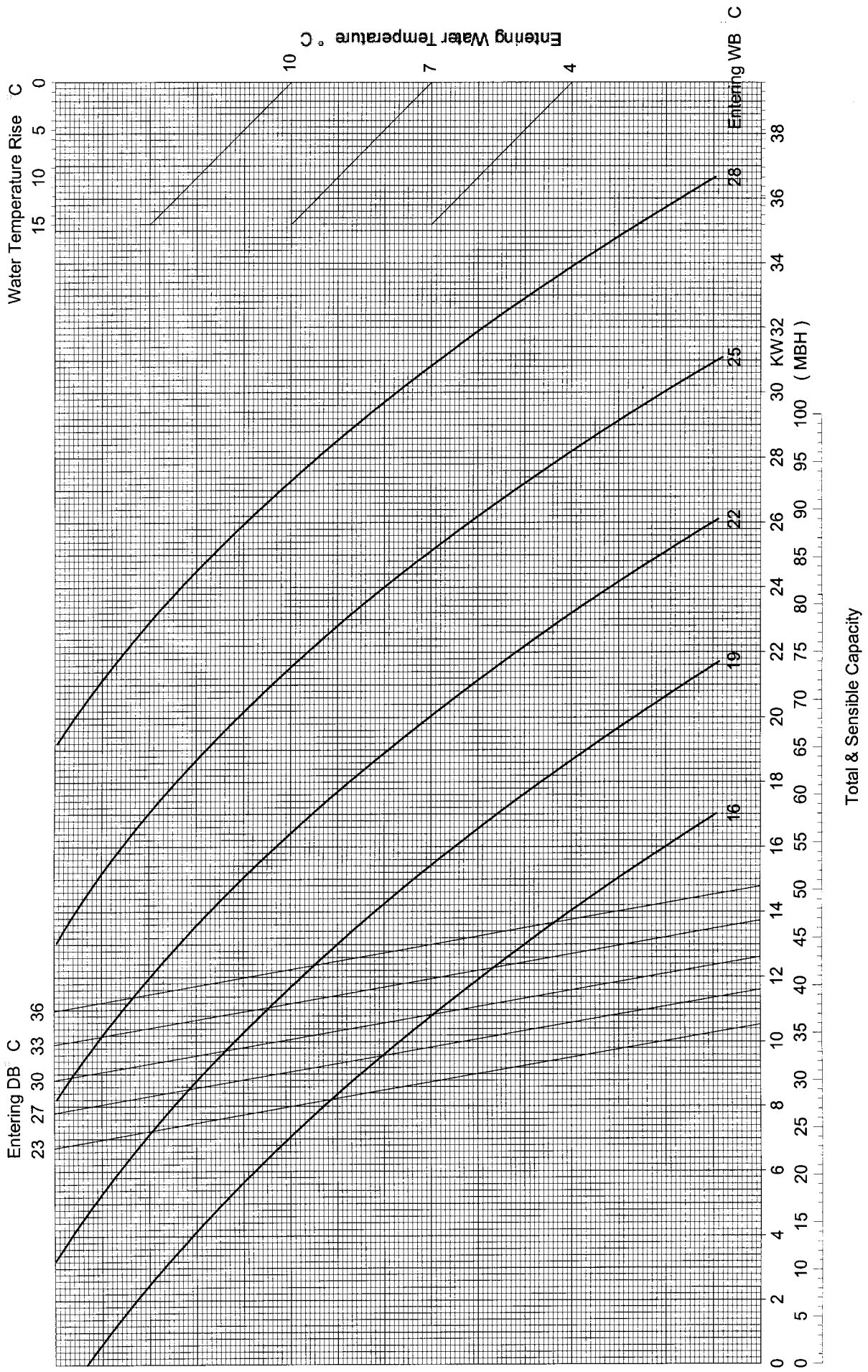

MCC010CW

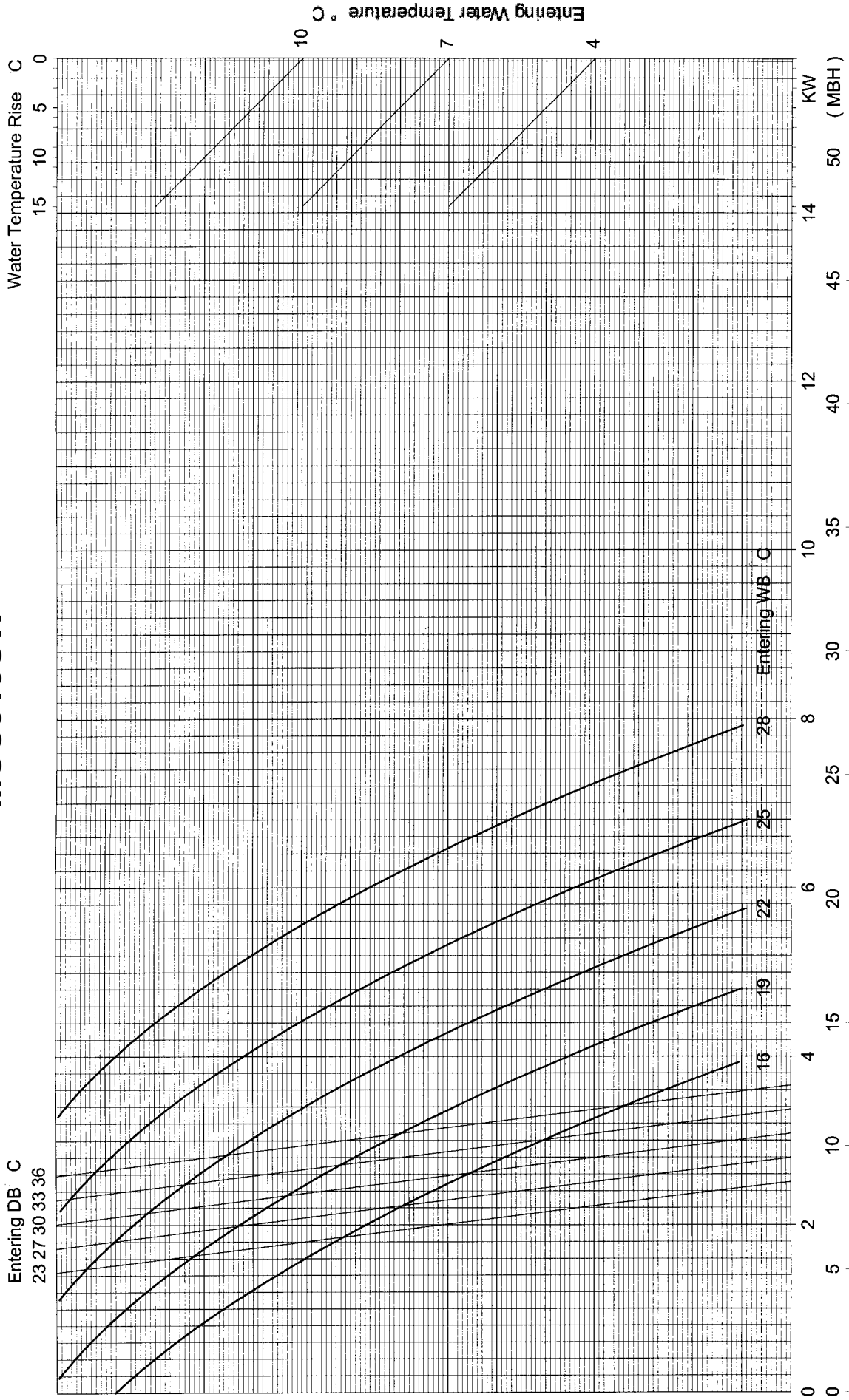

MCC015CW

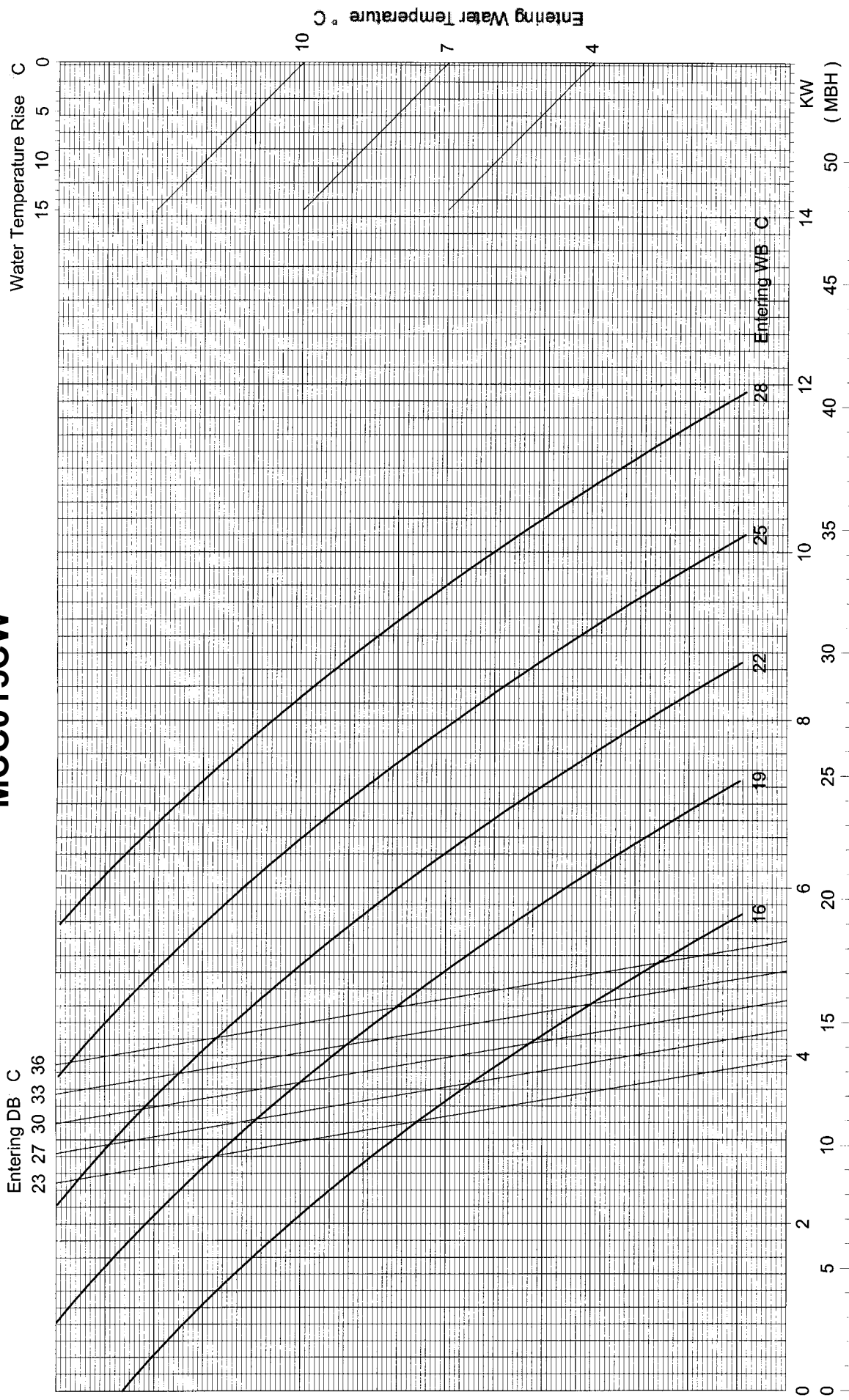

MCC020CW

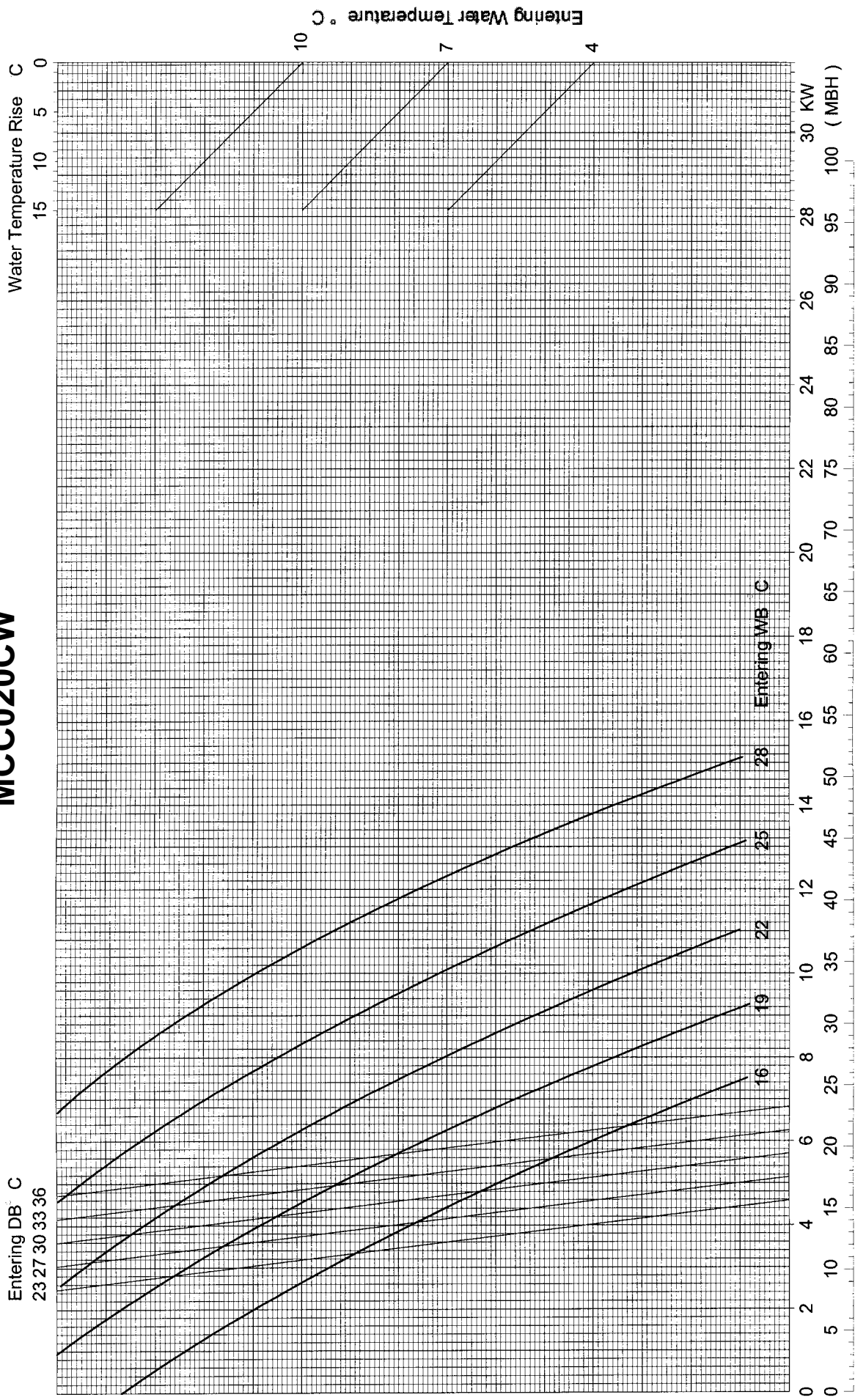

Total & Sensible Capacity

MCC025CW

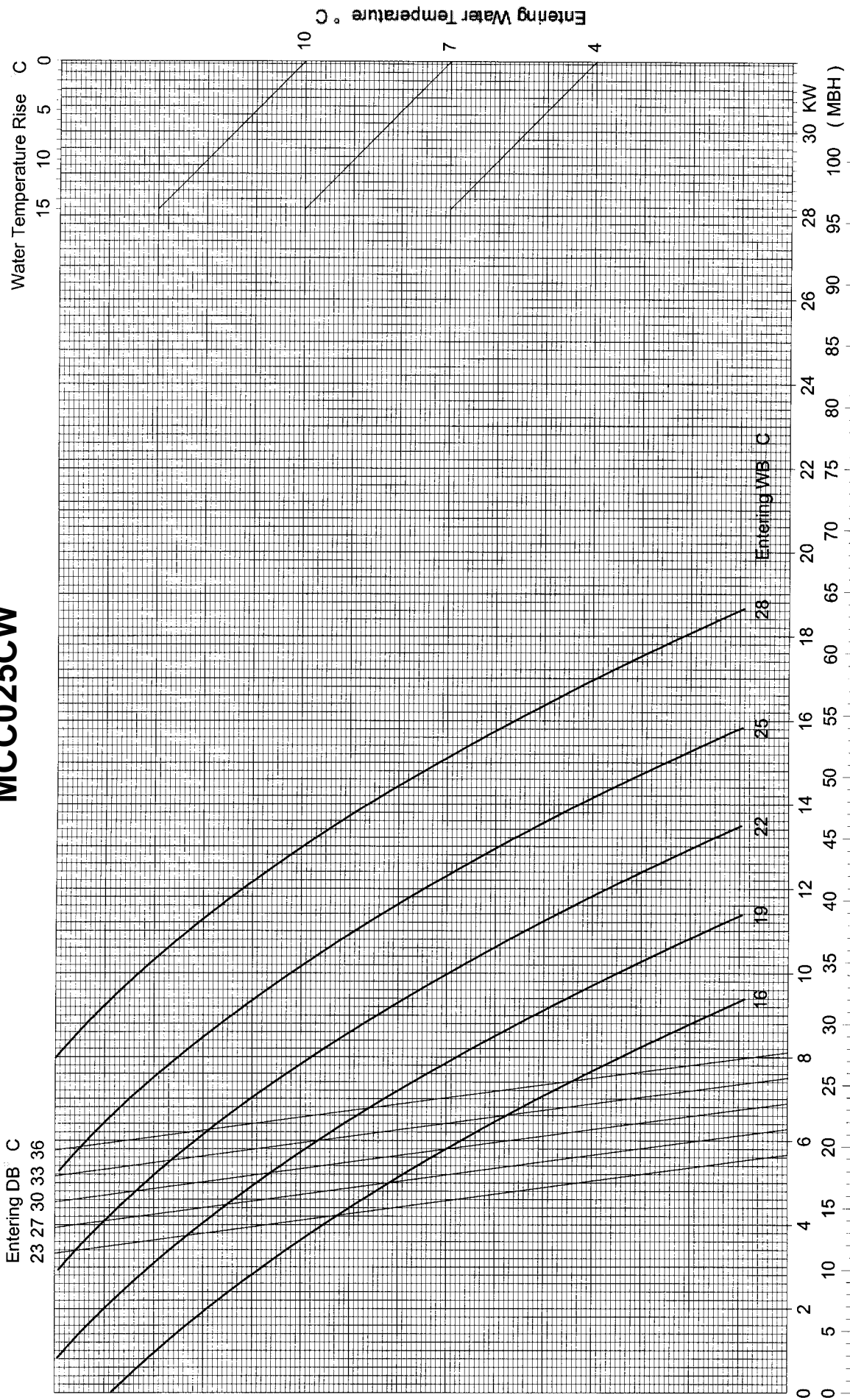

MCC030CW

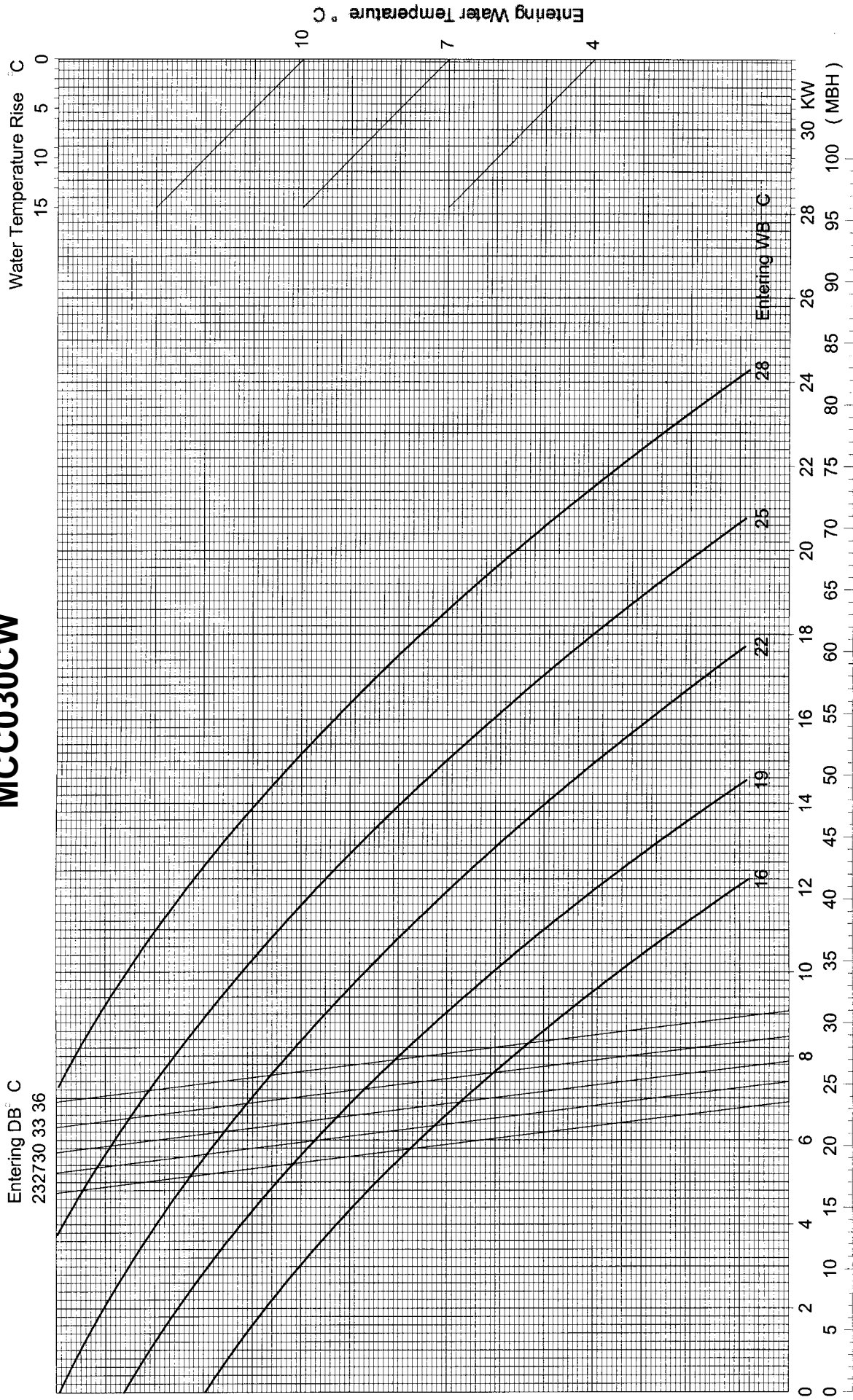

MCC040CW

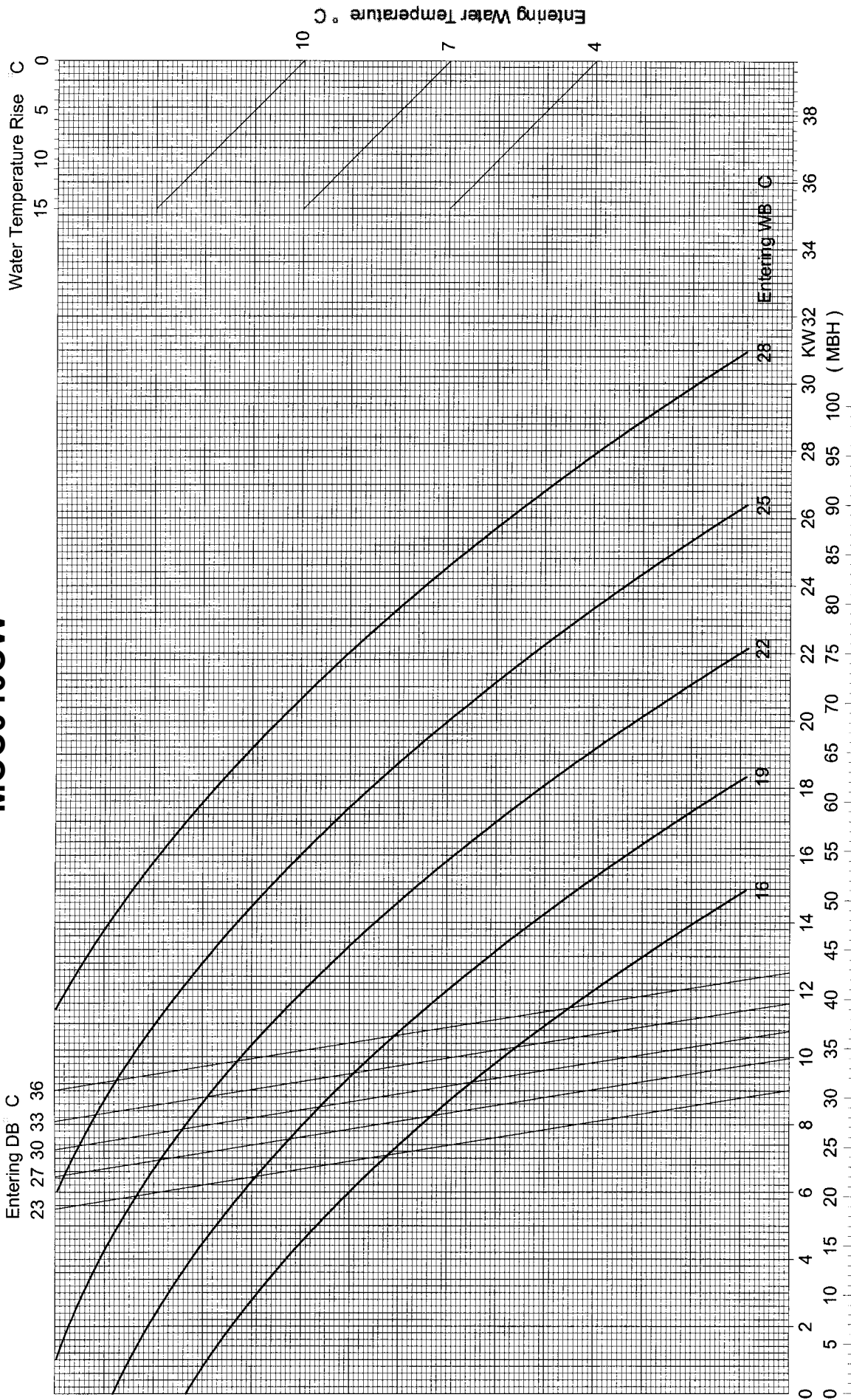

MCC050CW

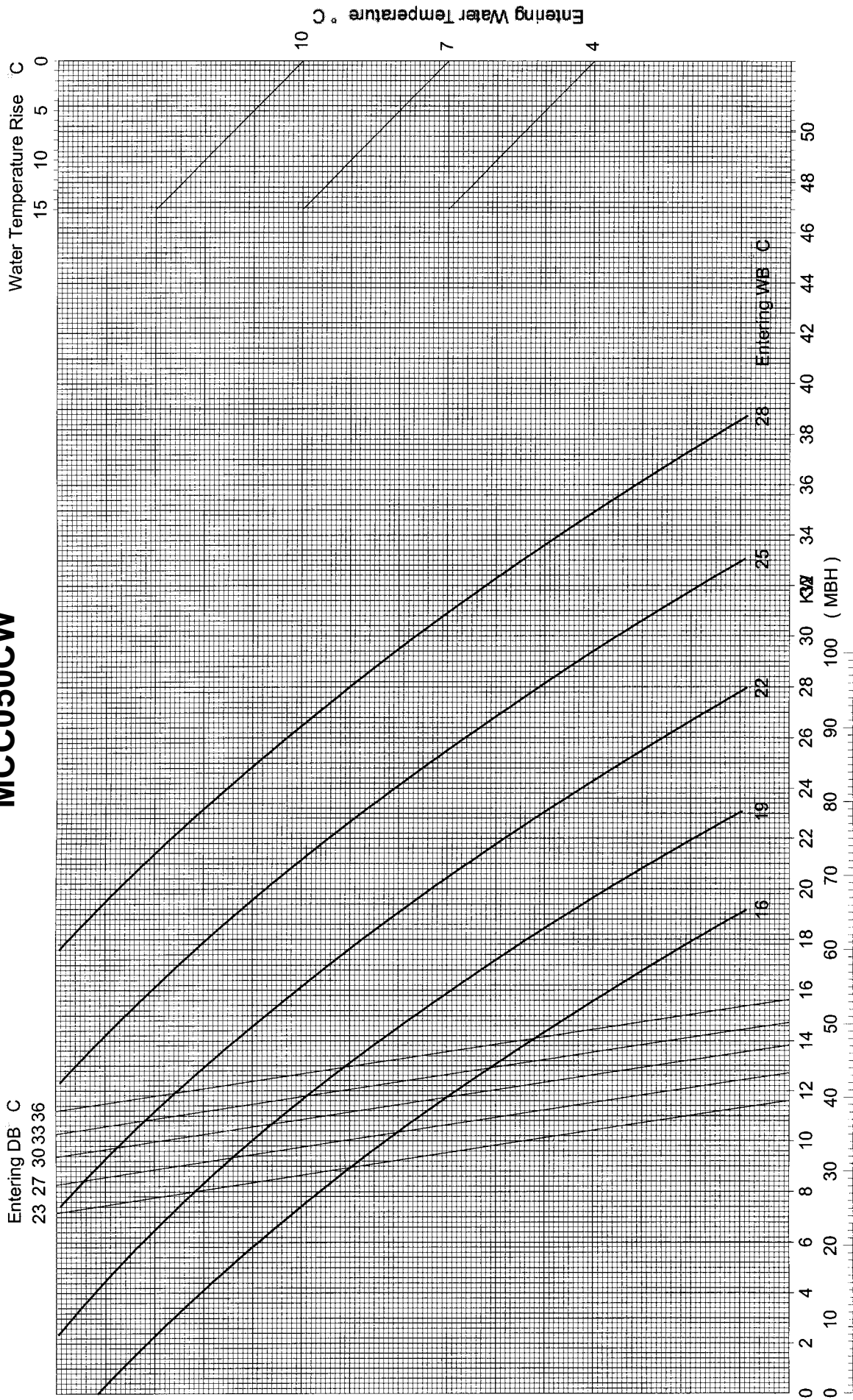

Total & Sensible Capacity

MCC060CW

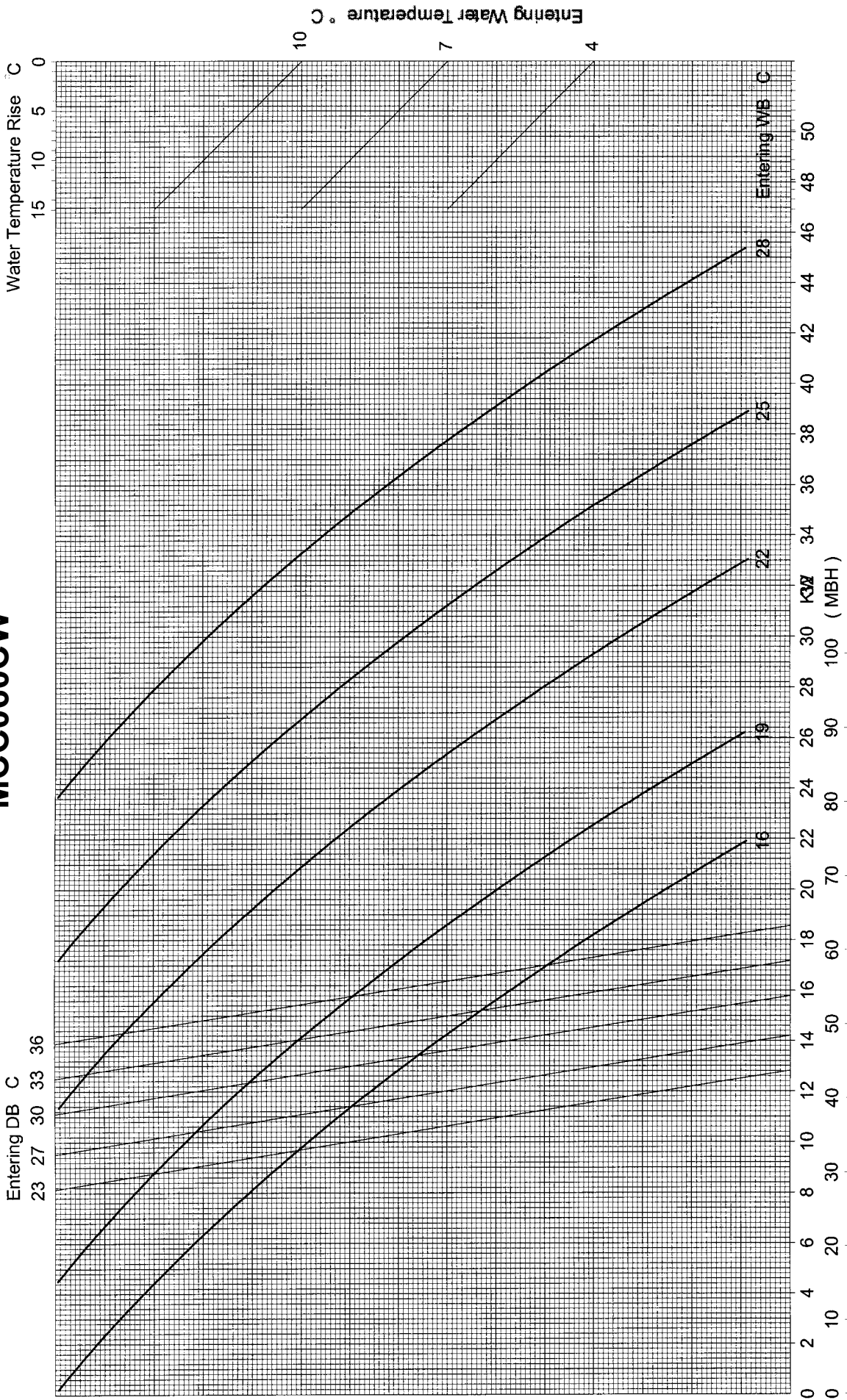

Total & Sensible Capacity

MCC028CW

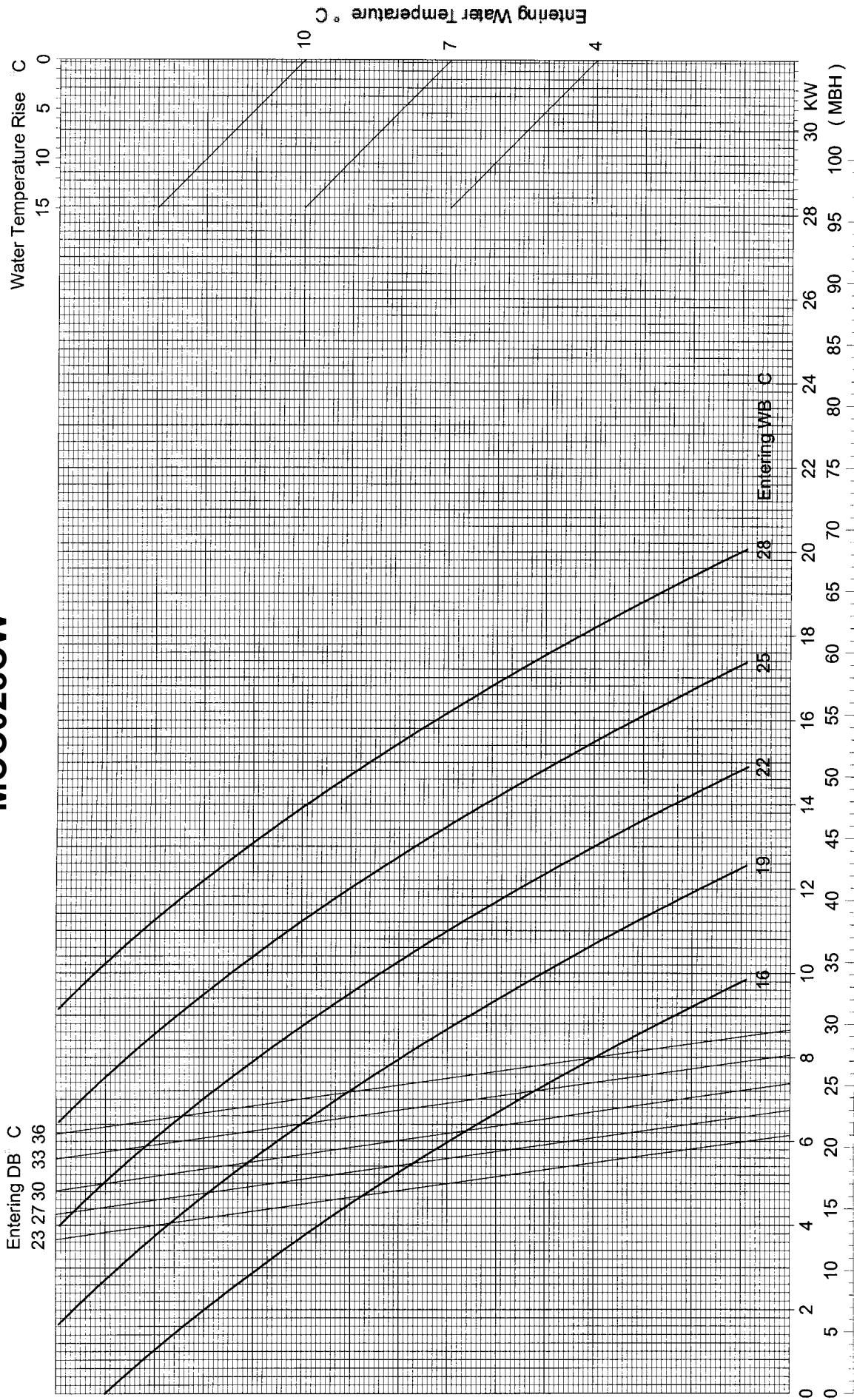

MCC038CW

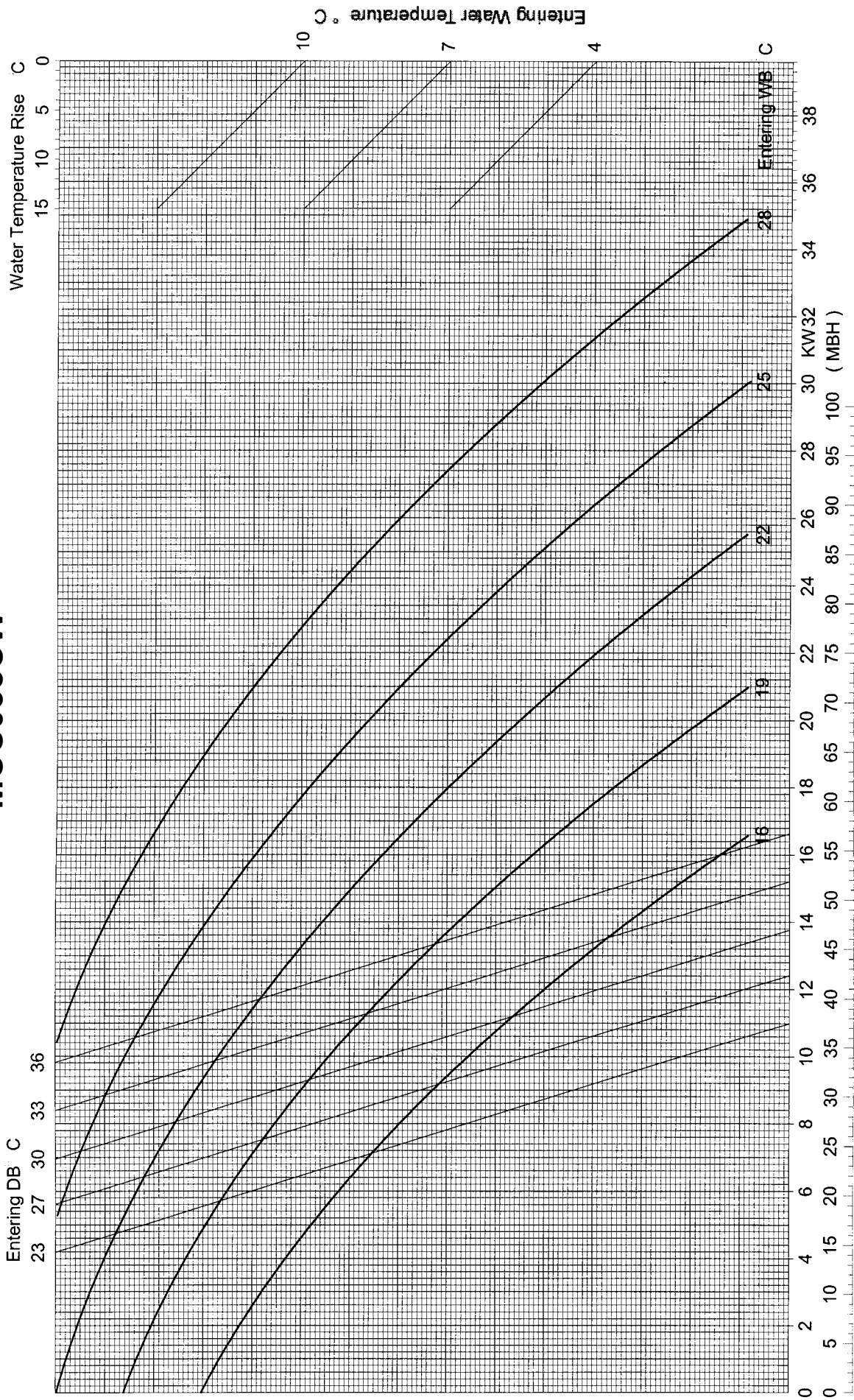

MDB075BW

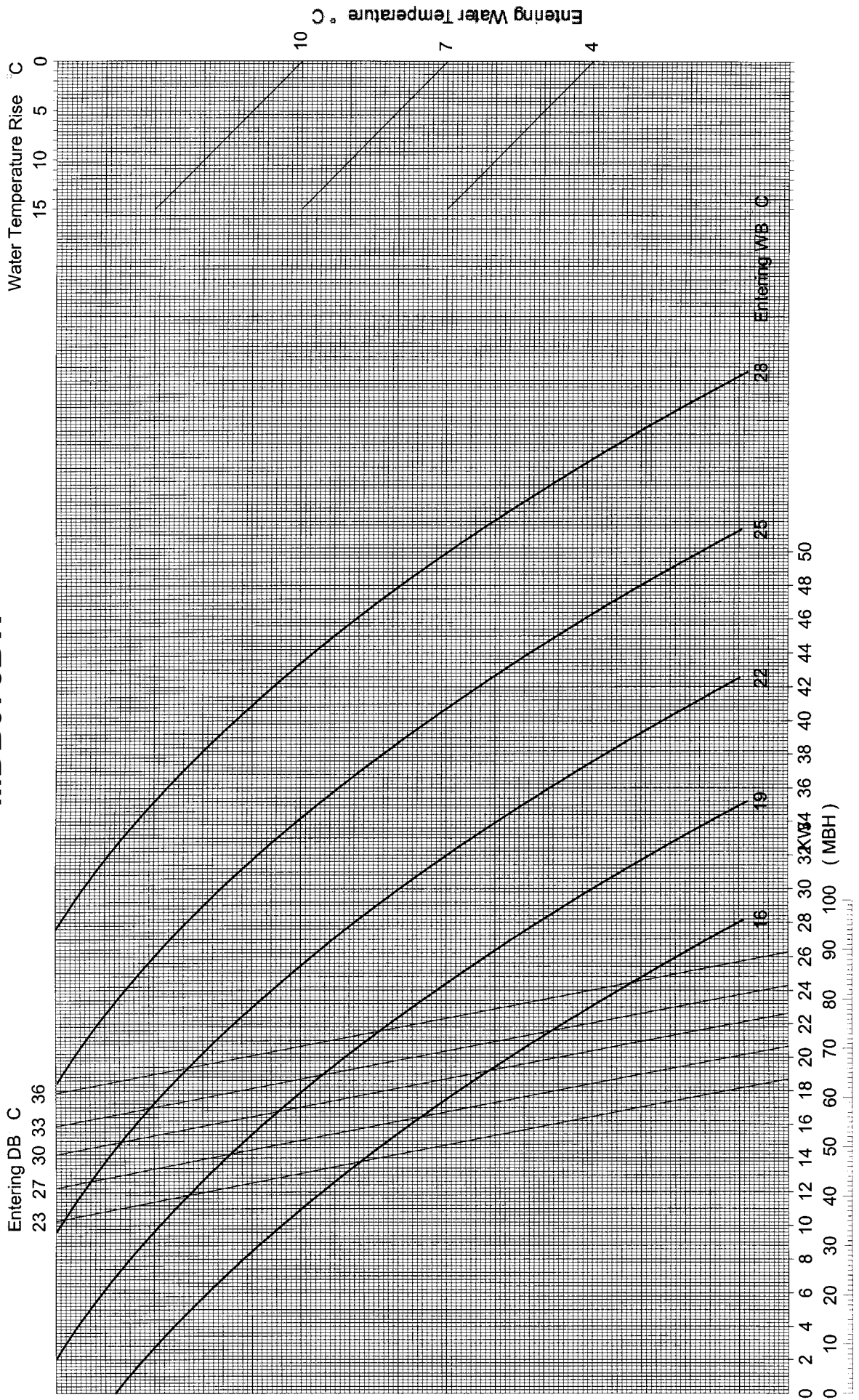

MDB100BW

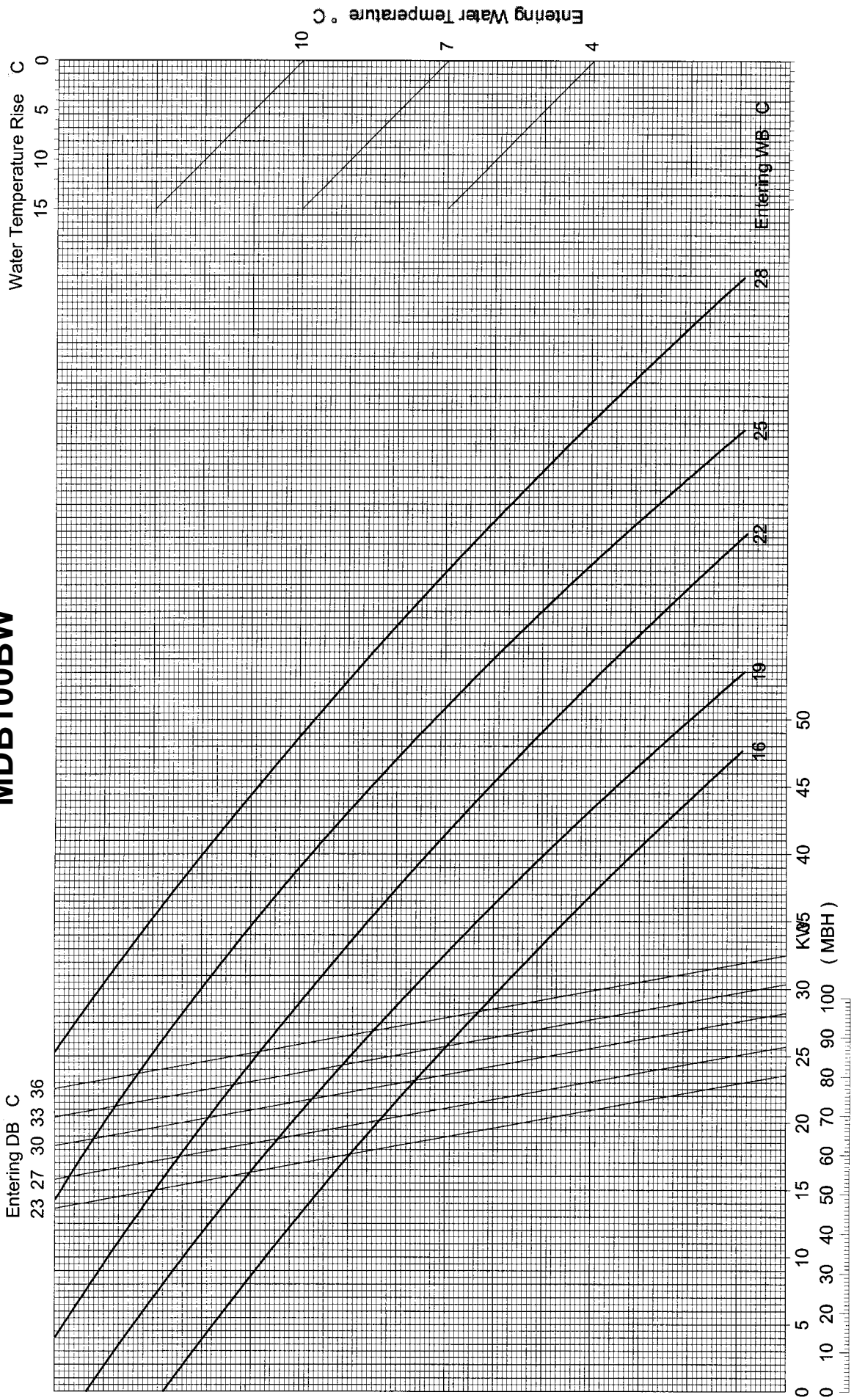

Total & Sensible Capacity

MDB125BW

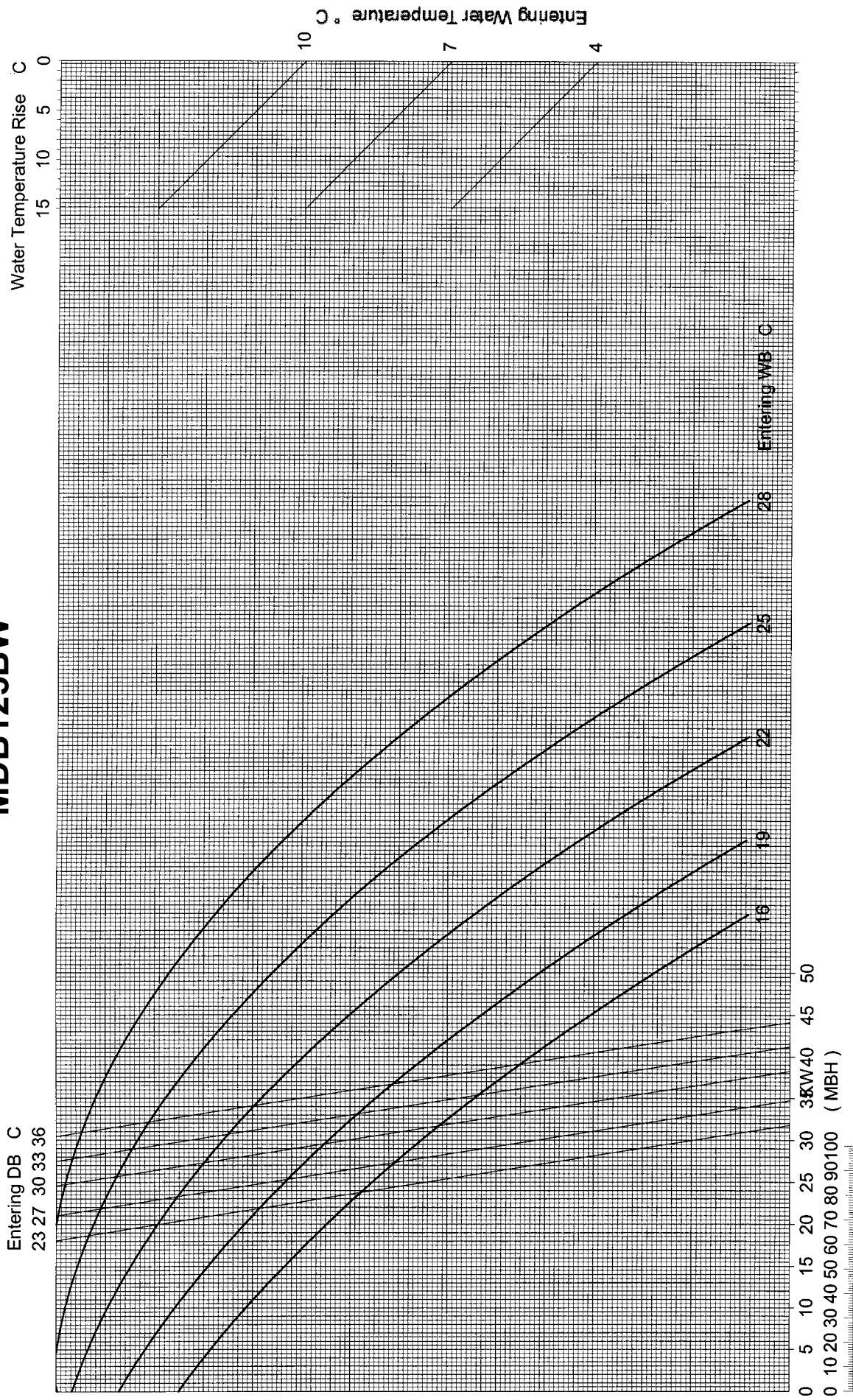

Total & Sensible Capacity

MDB150BW

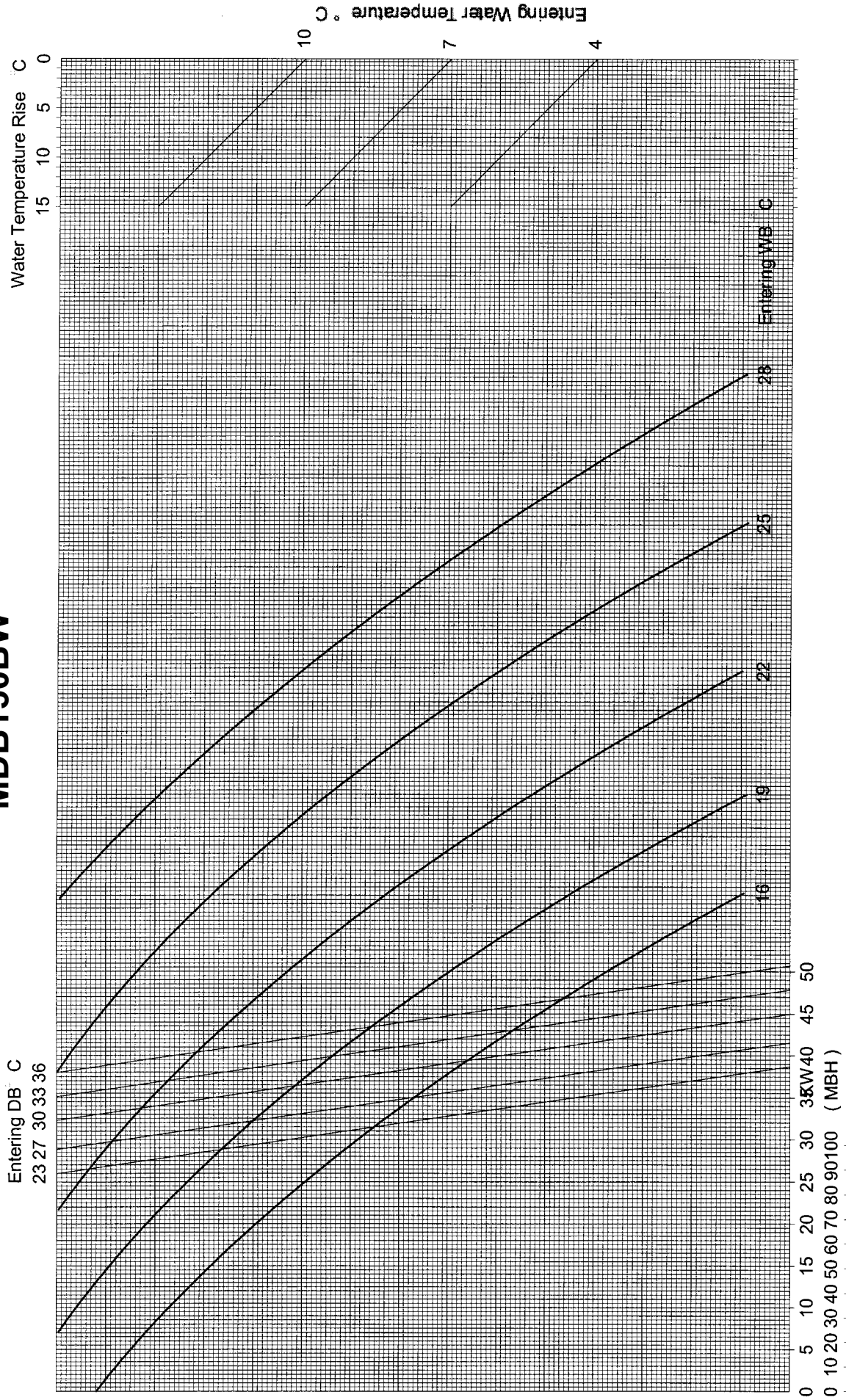

Total & Sensible Capacity

Heating Capacity Performance Chart

Wall Mounted Type

MWM005FW

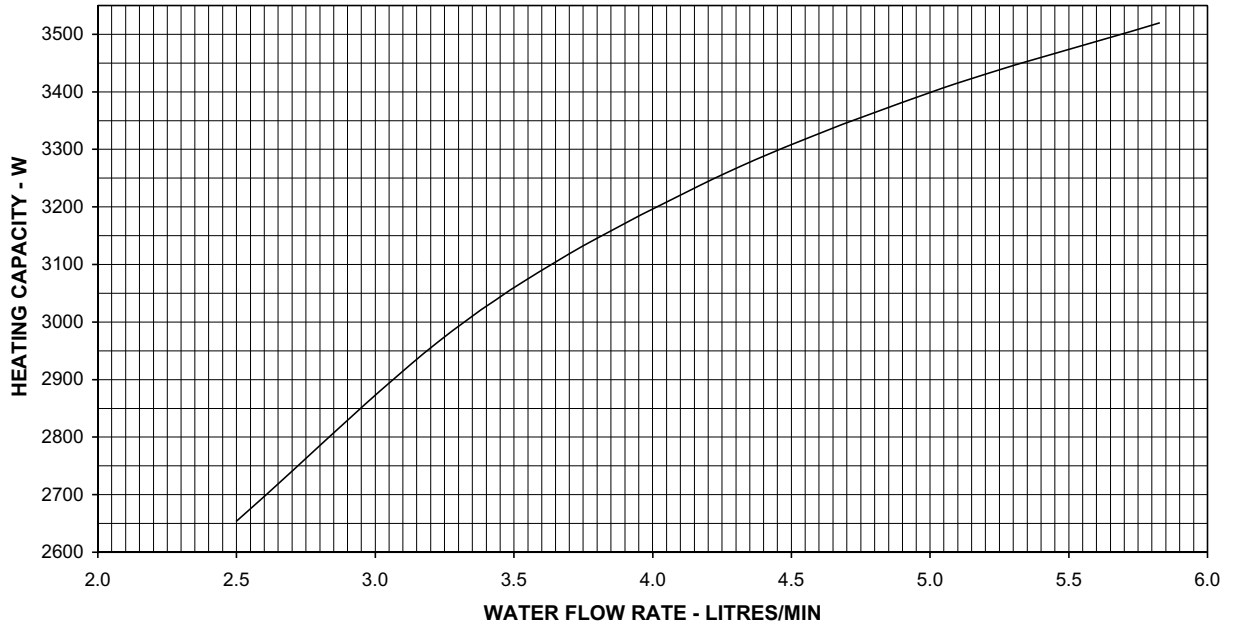

MWM007FW

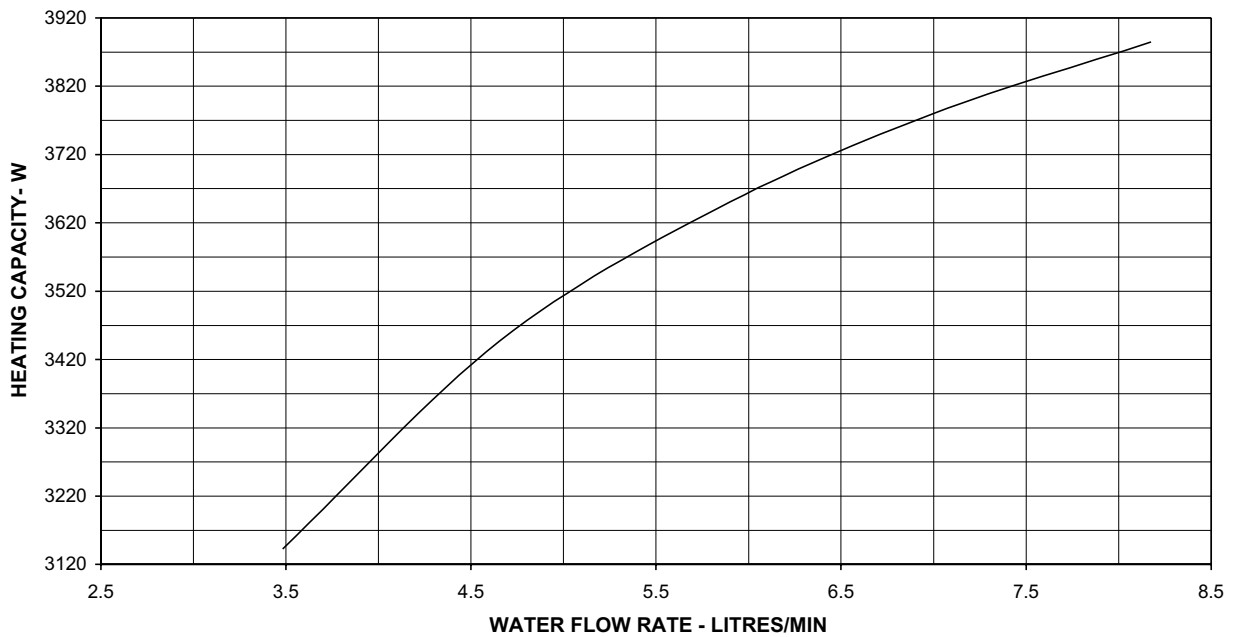

MWM010FW

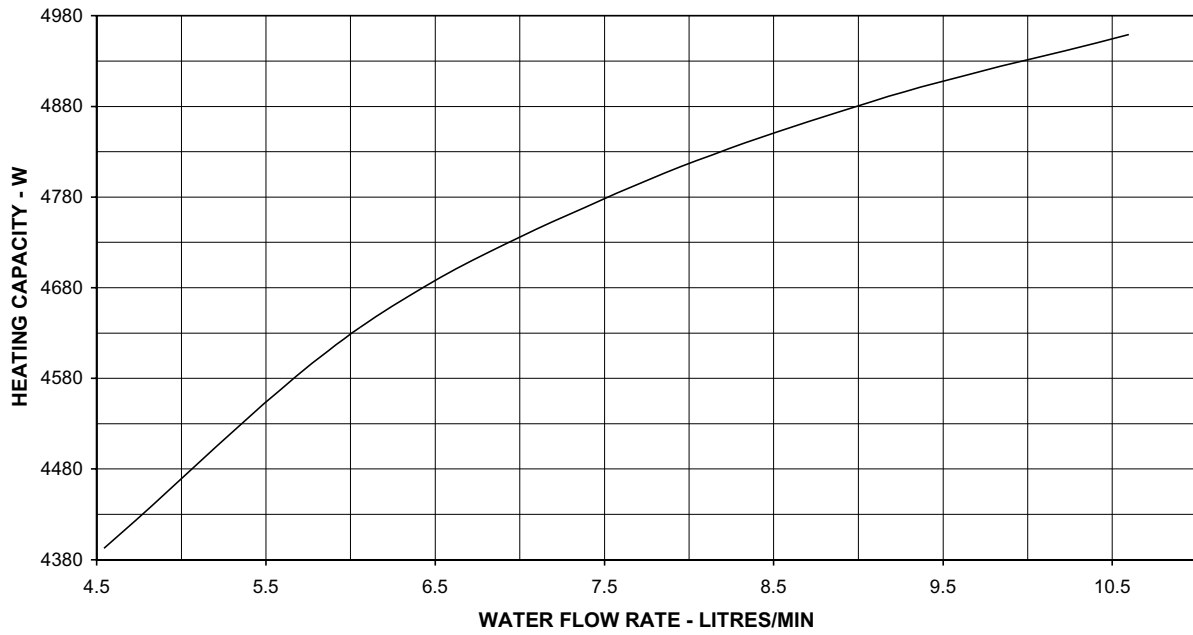

MWM015FW

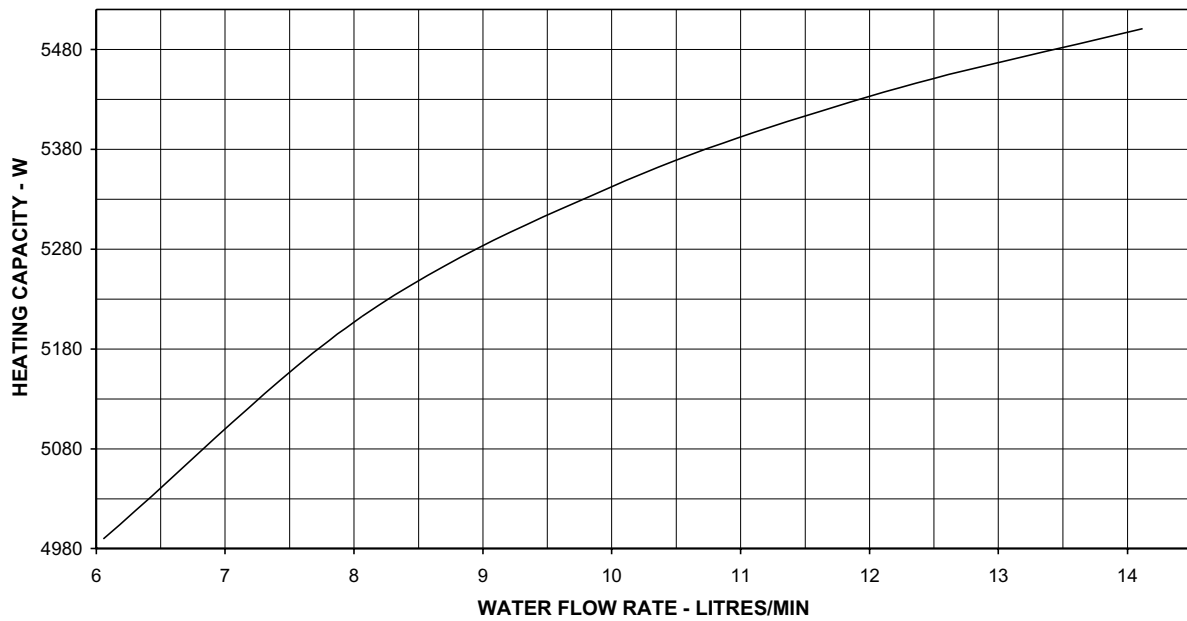

MWM020FW

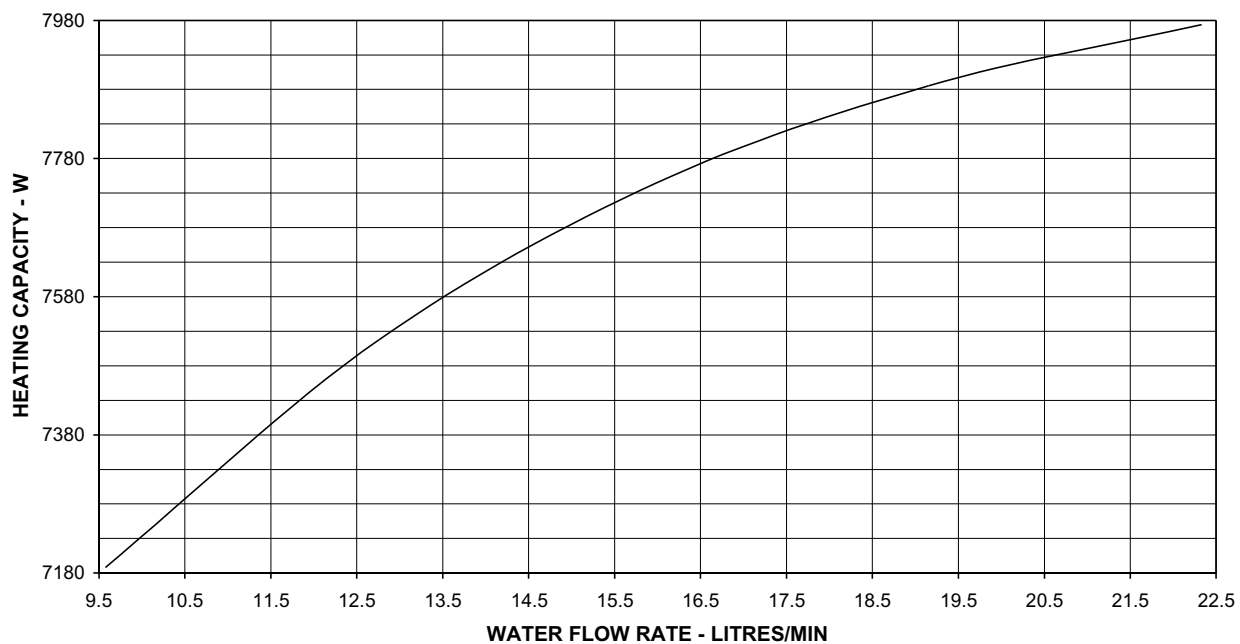

MWM025FW

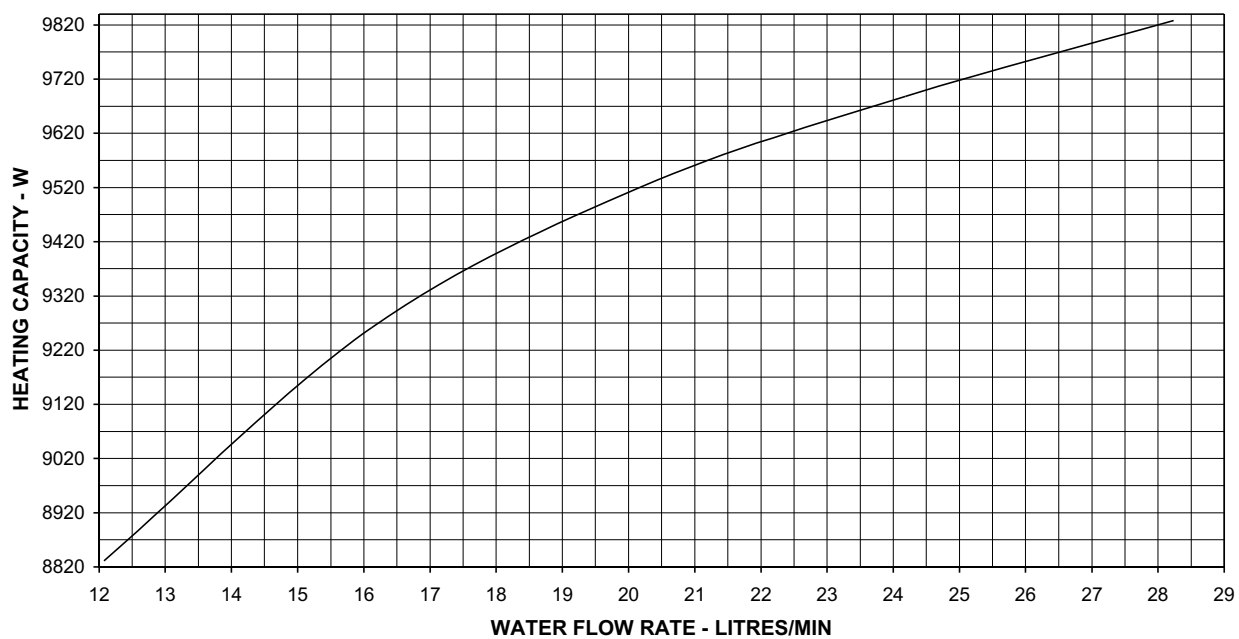

Ceiling Cassette Type

MCK020AW

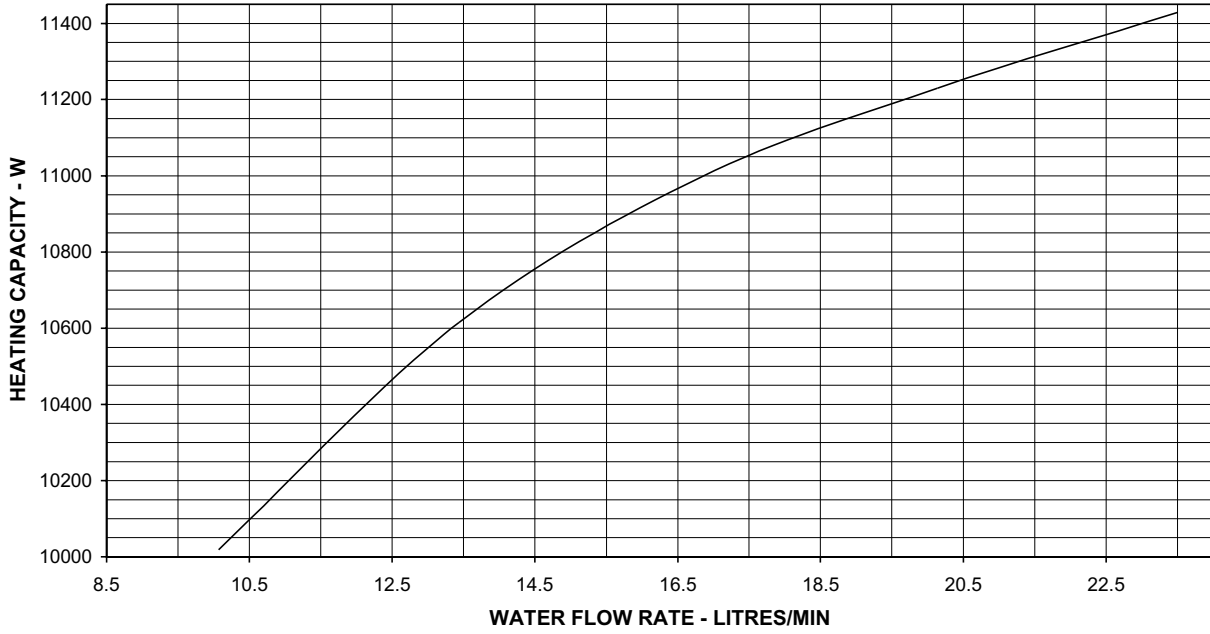

MCK025AW

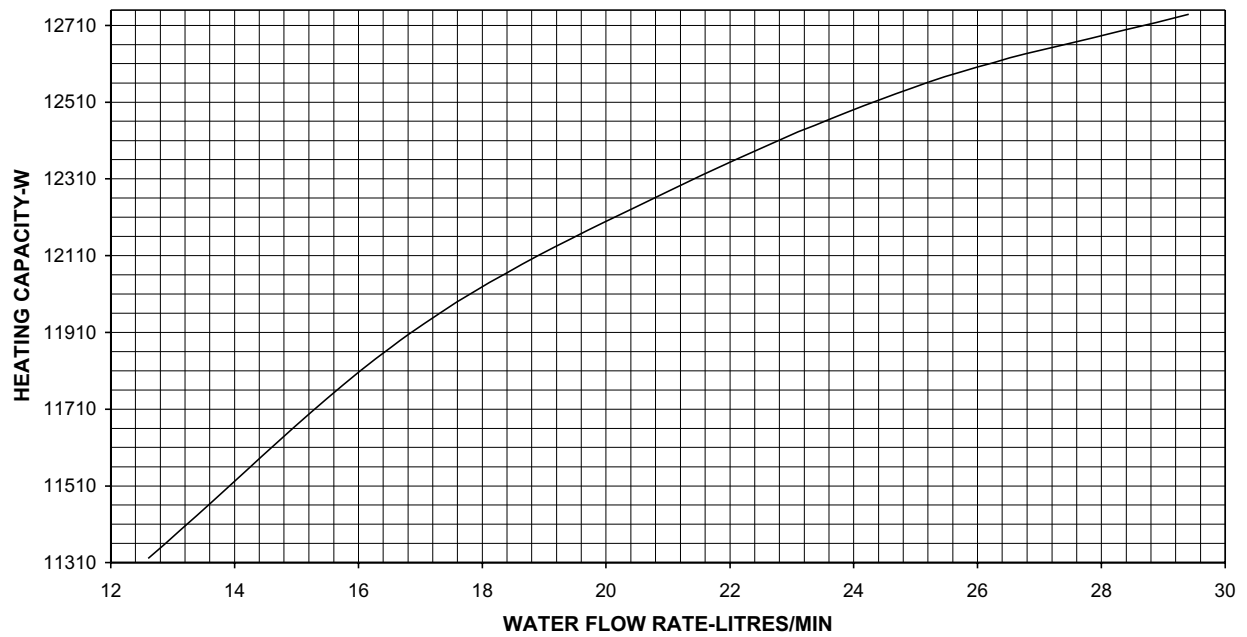

MCK030AW

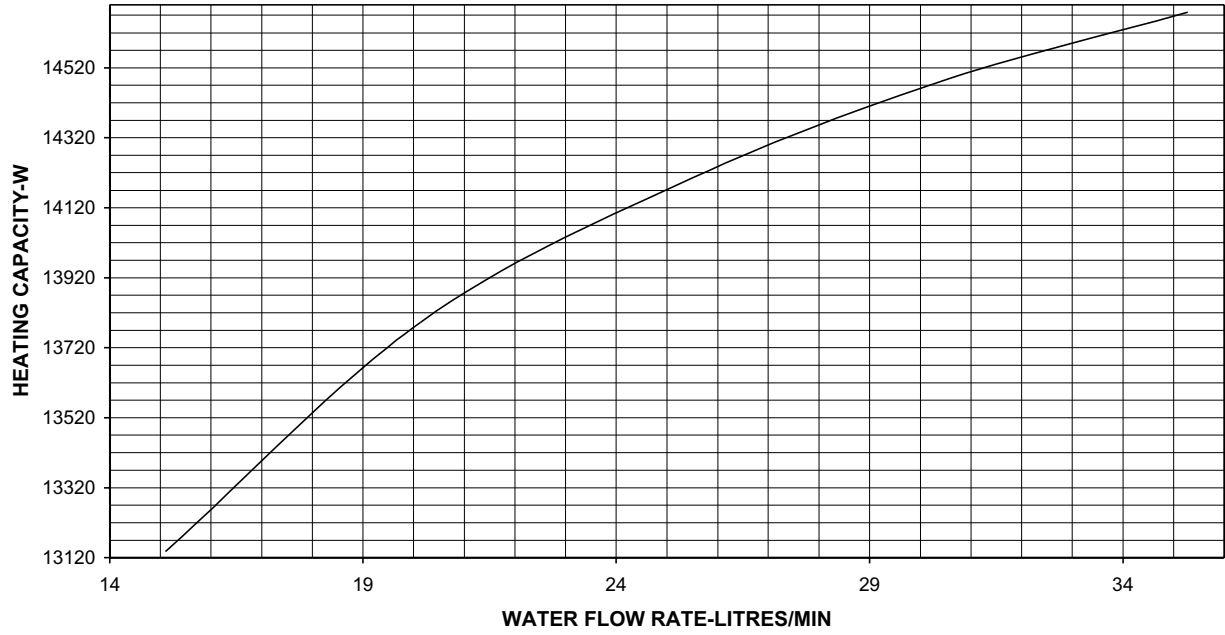

MCK040AW

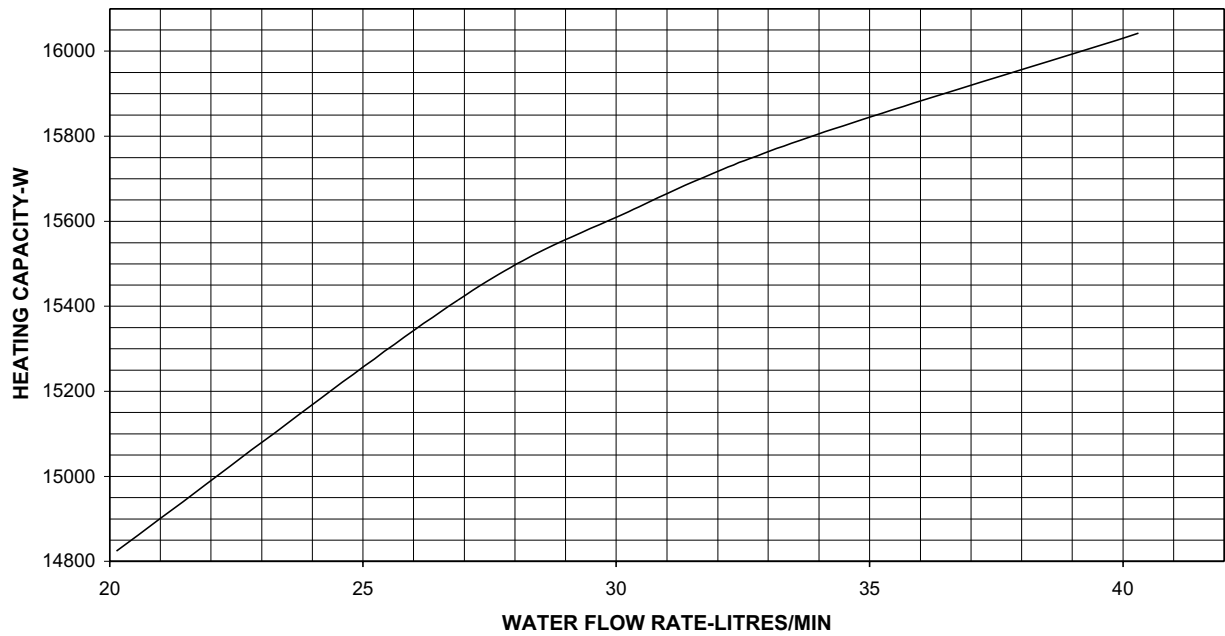

MCK050AW

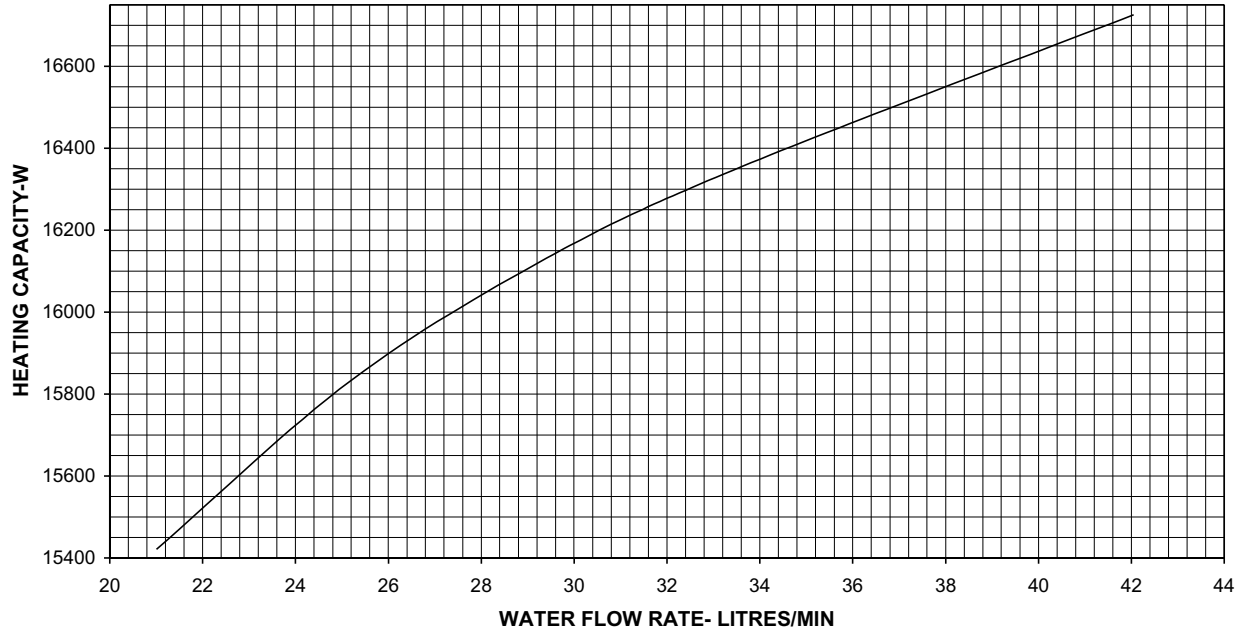

MCK015BW

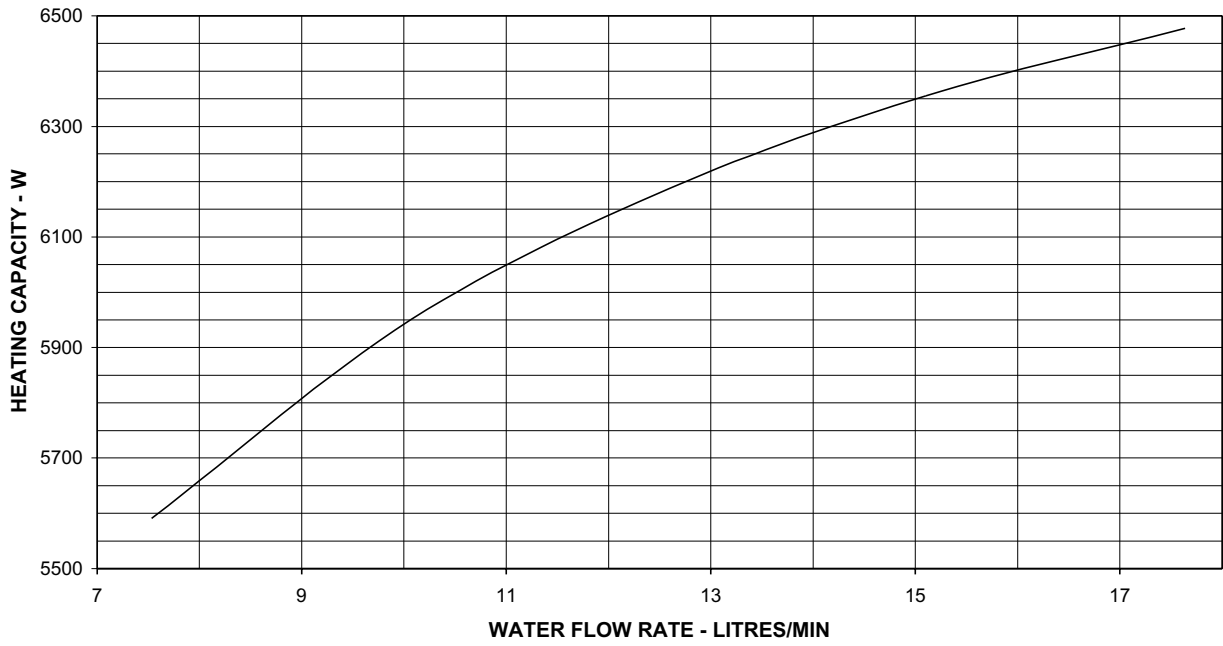

MCK020BW

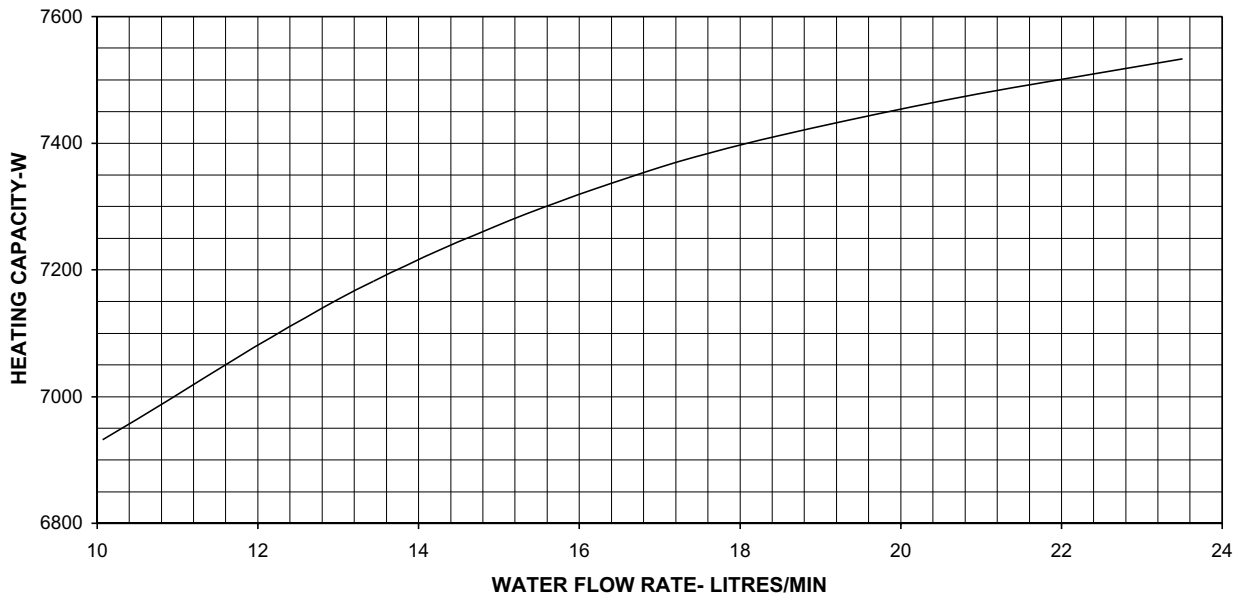

MCK025BW

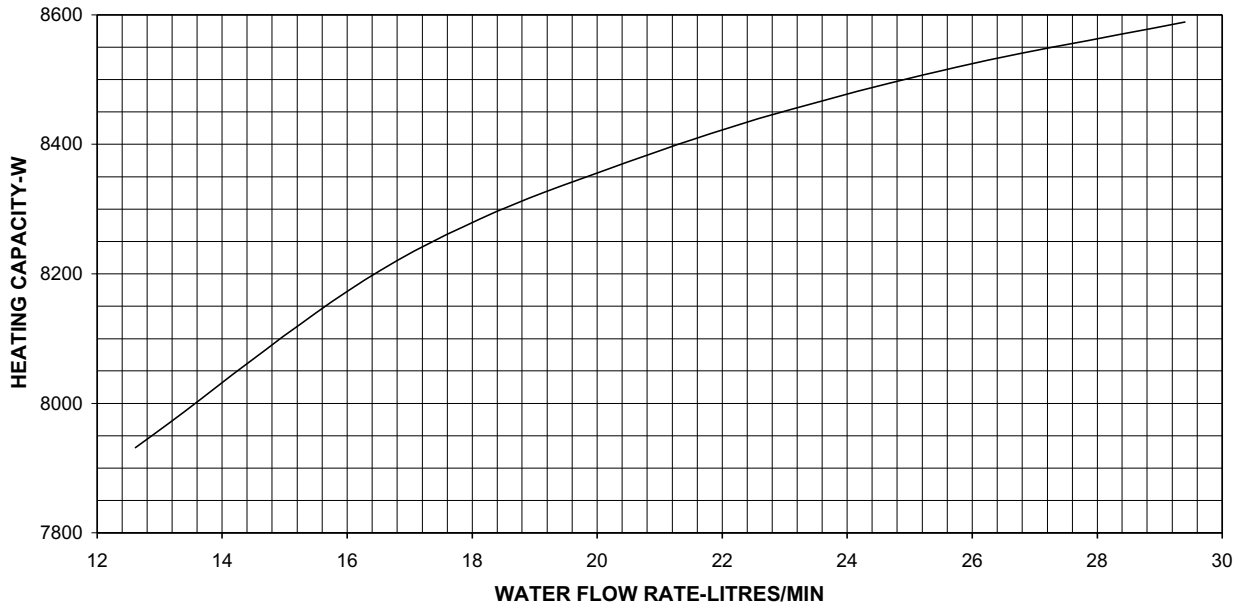

MCK030BW

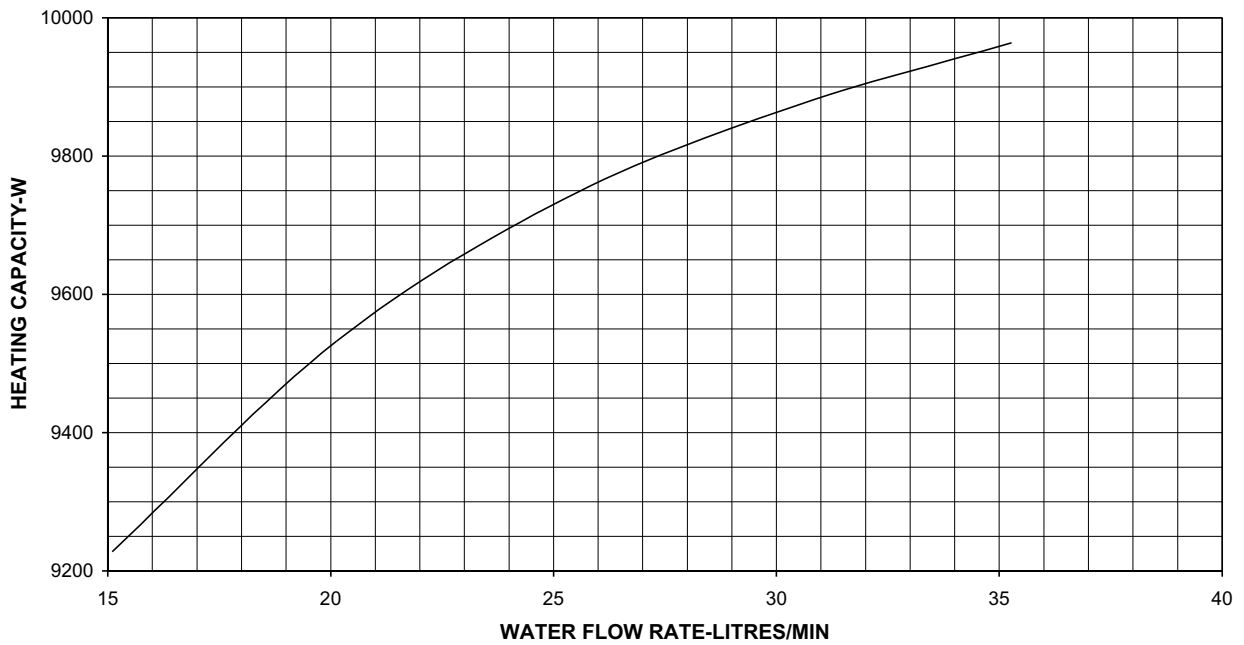

Ceiling Exposed Type

MCM020DW

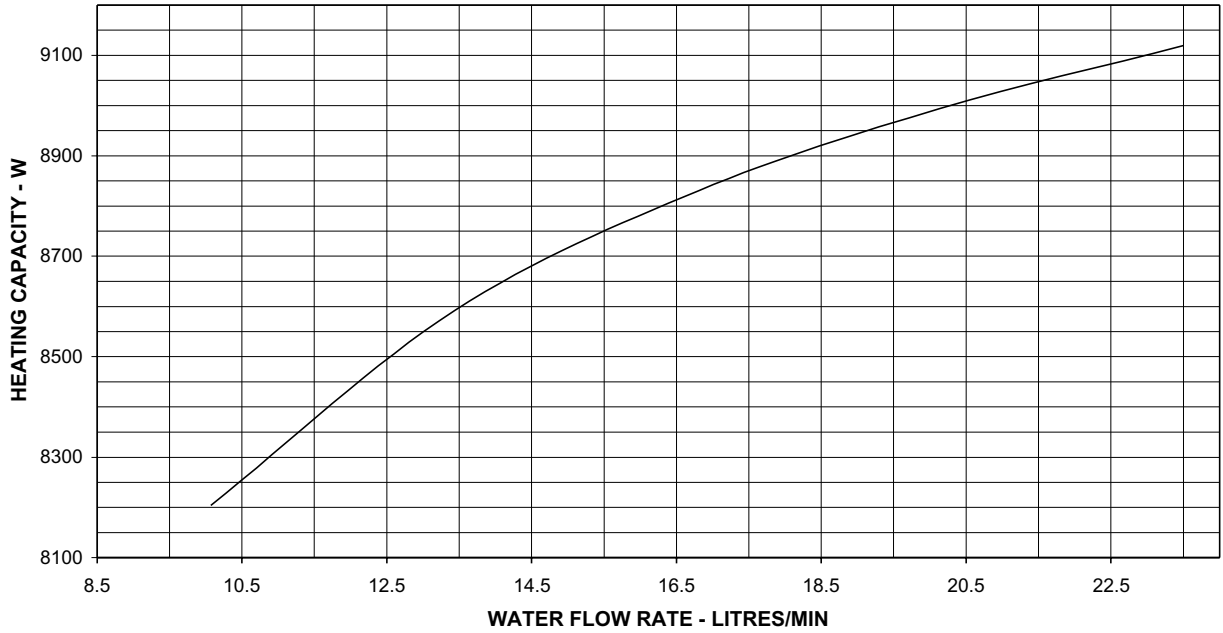

MCM025DW

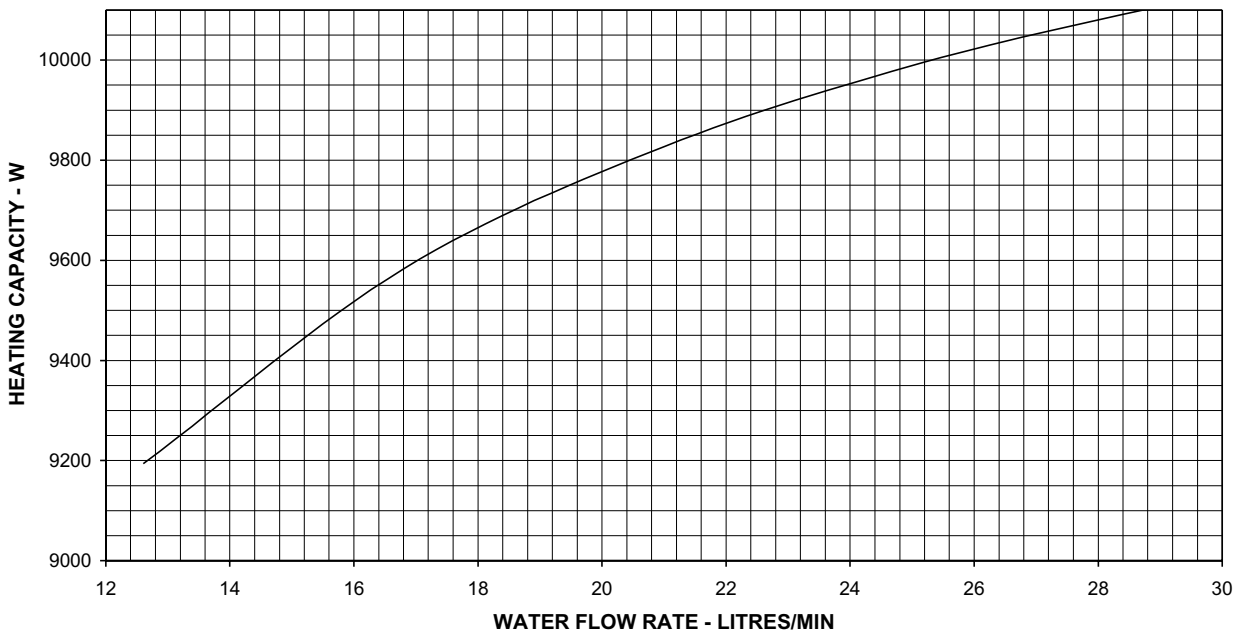

MCM030DW

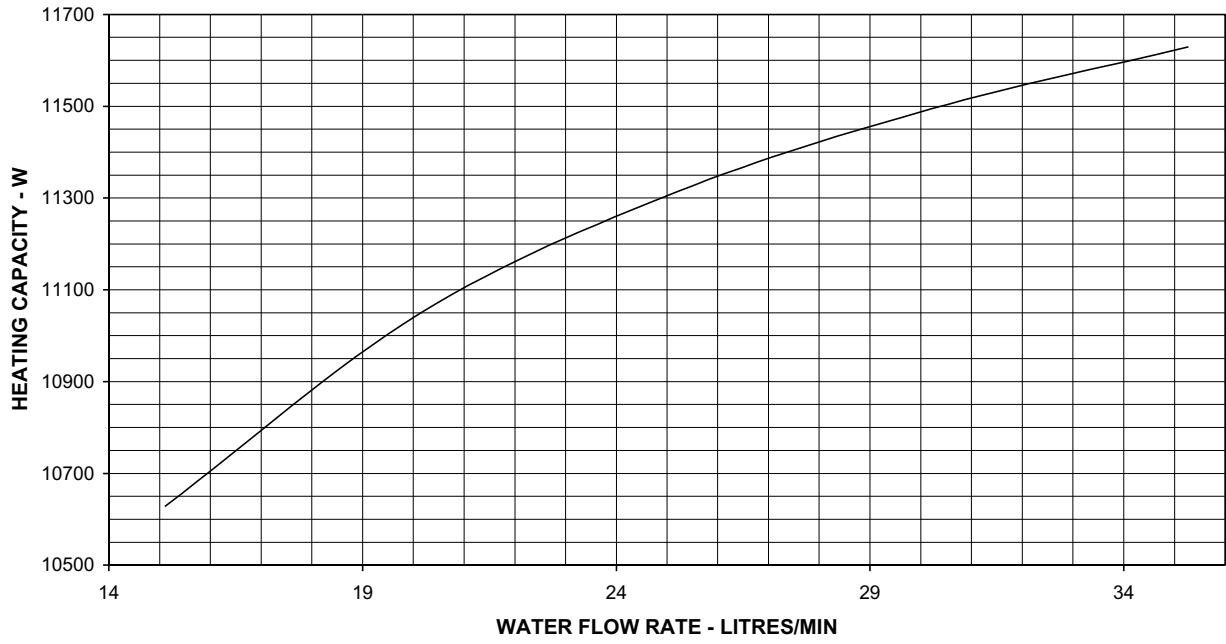

MCM040DW

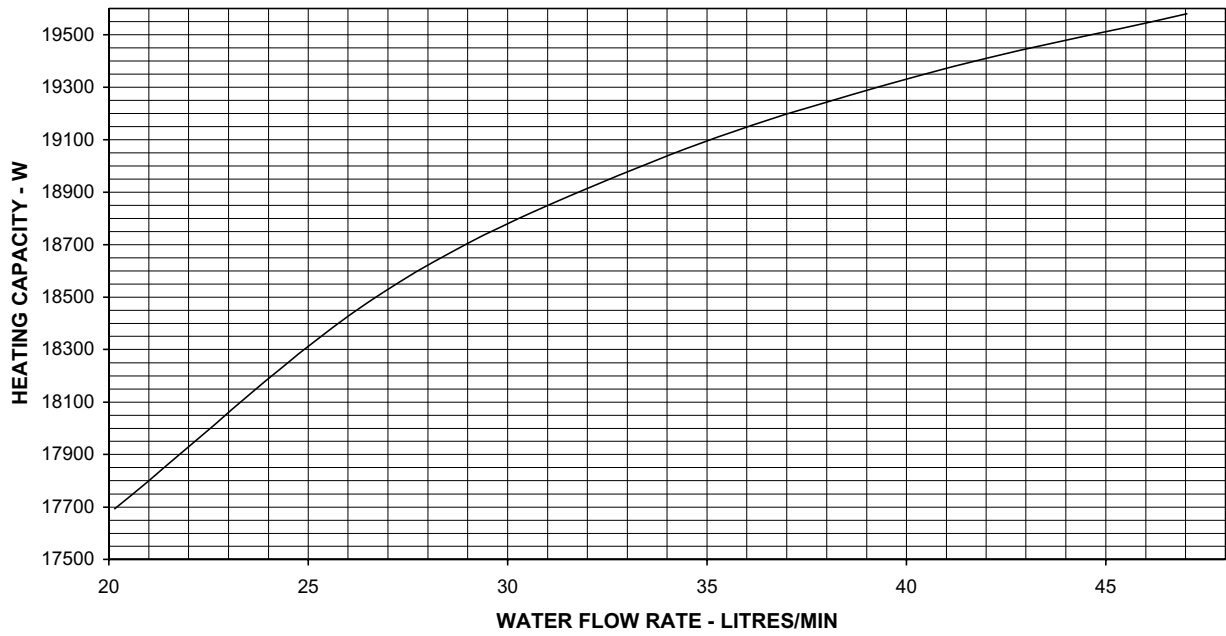

MCM050DW

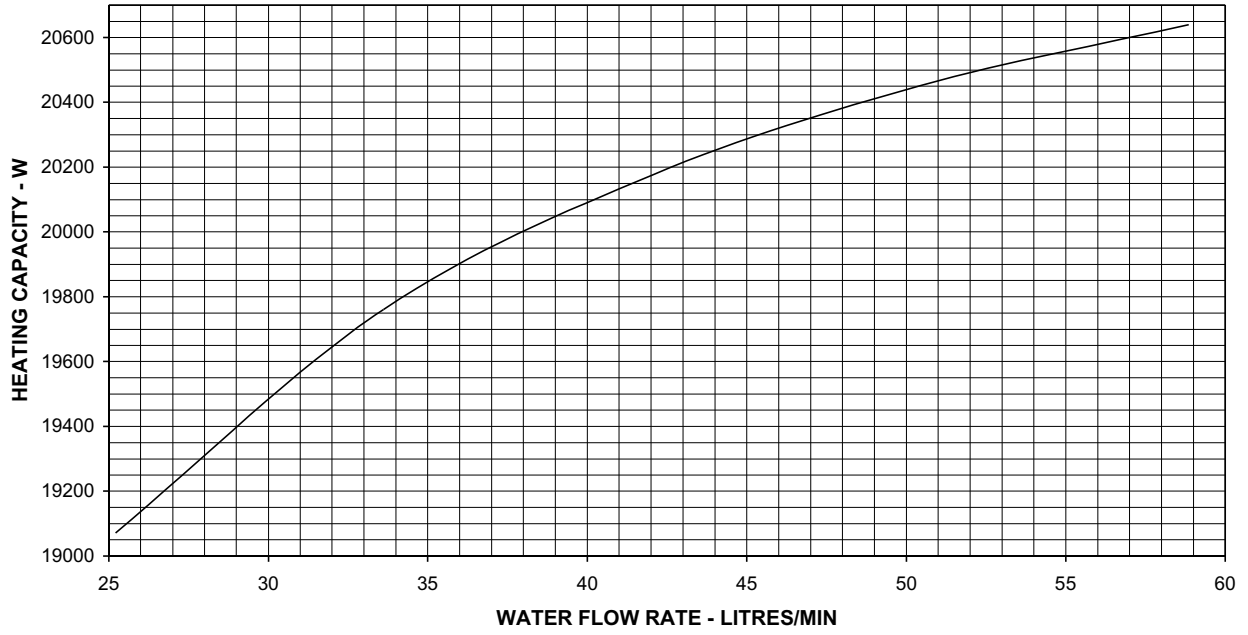

Ceiling Concealed Type

MCC010CW

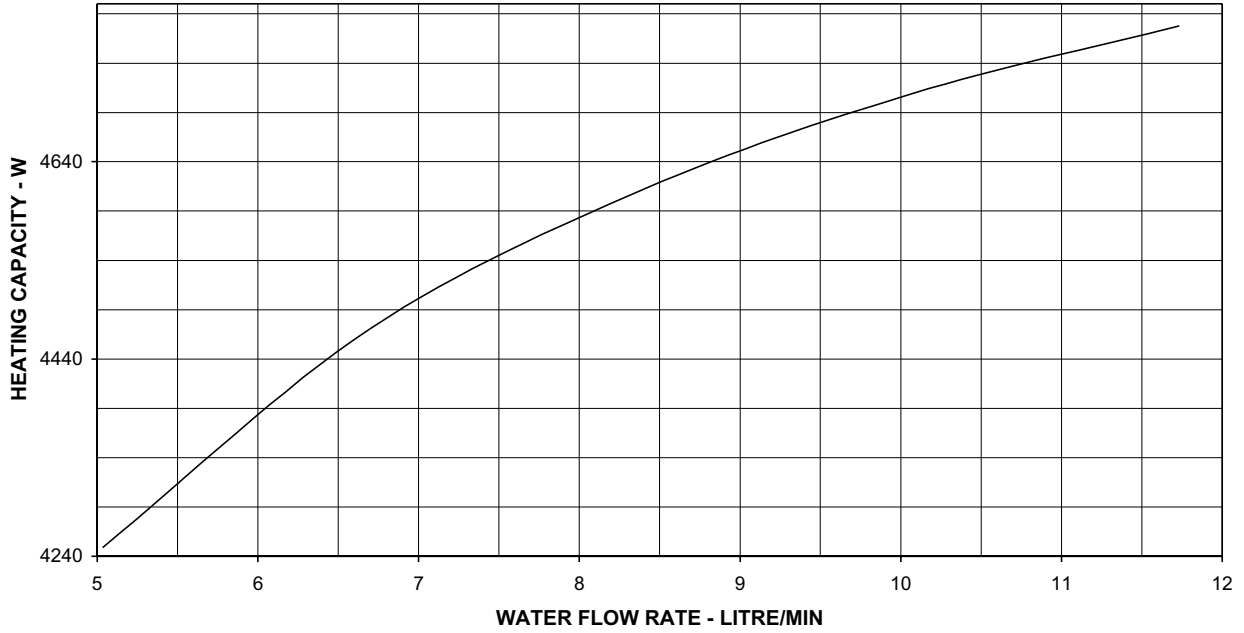

MCC015CW

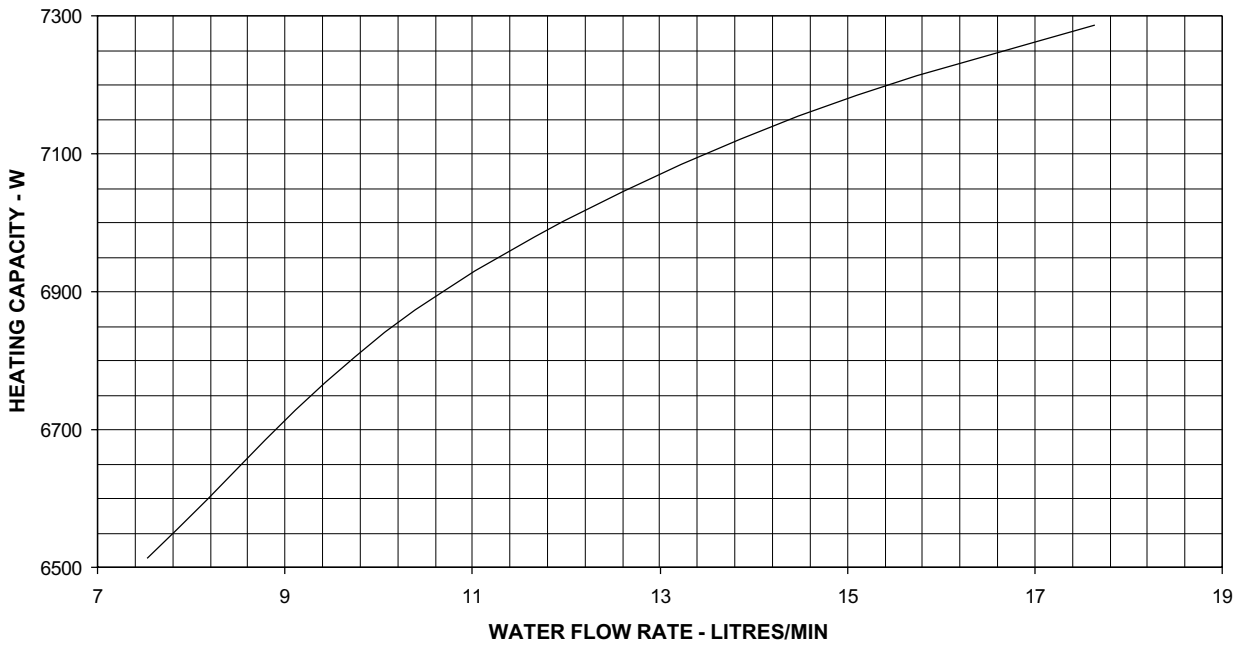

MCC020CW

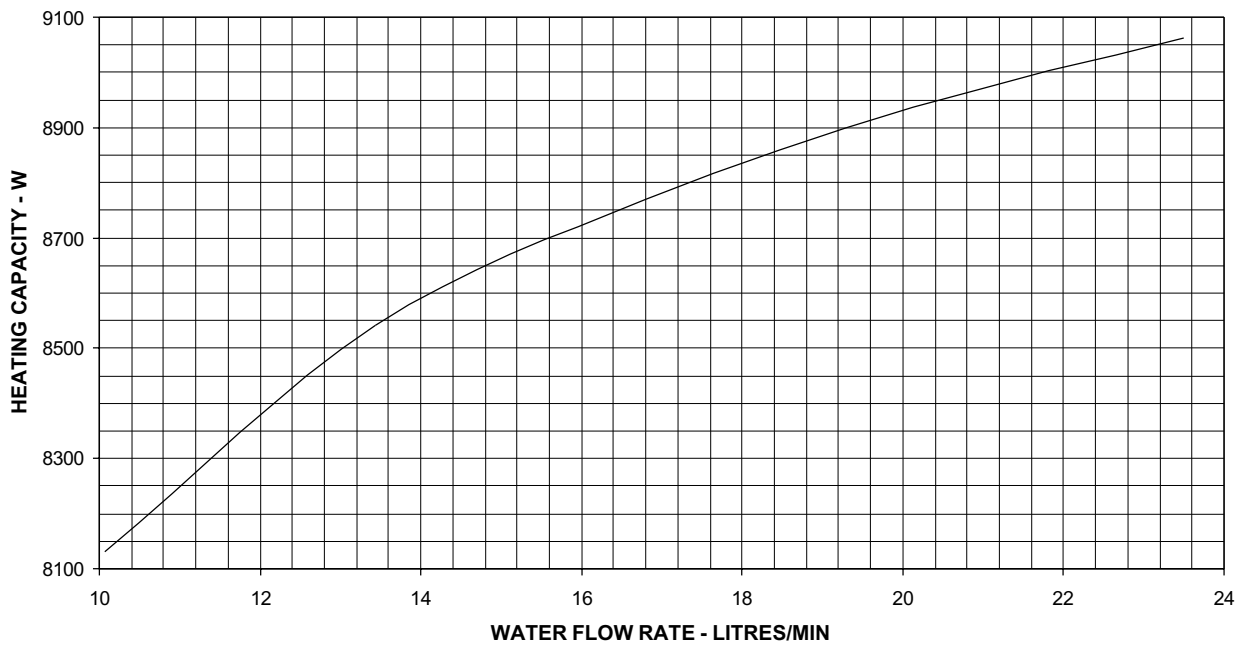

MCC025CW

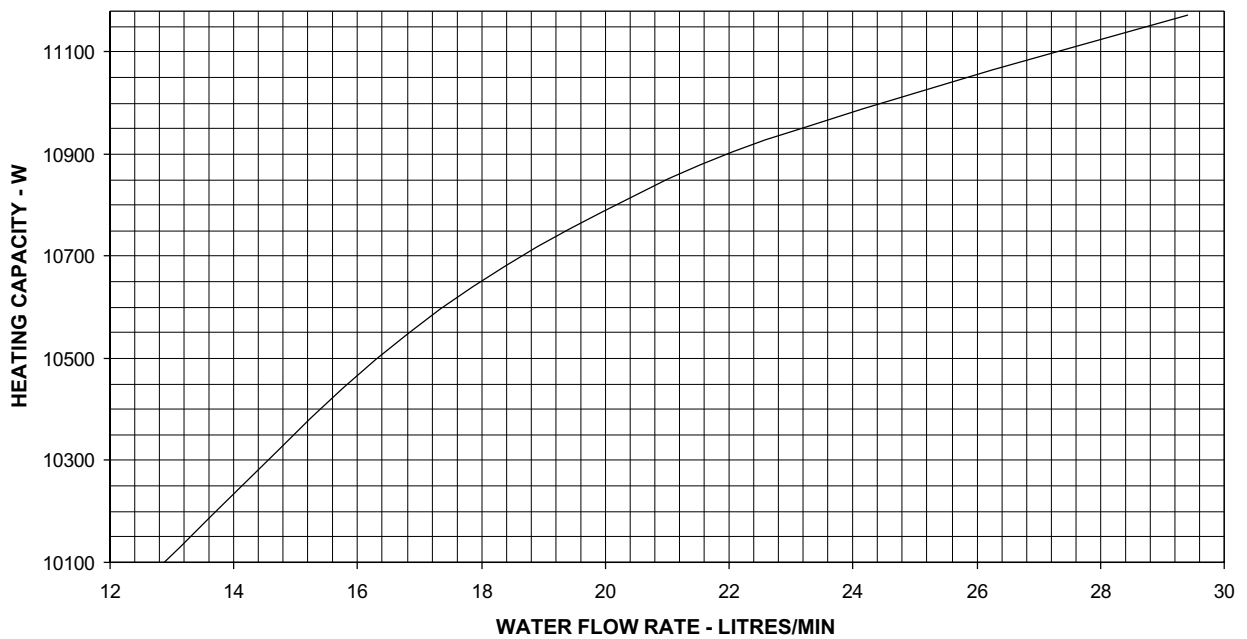

MCC030CW

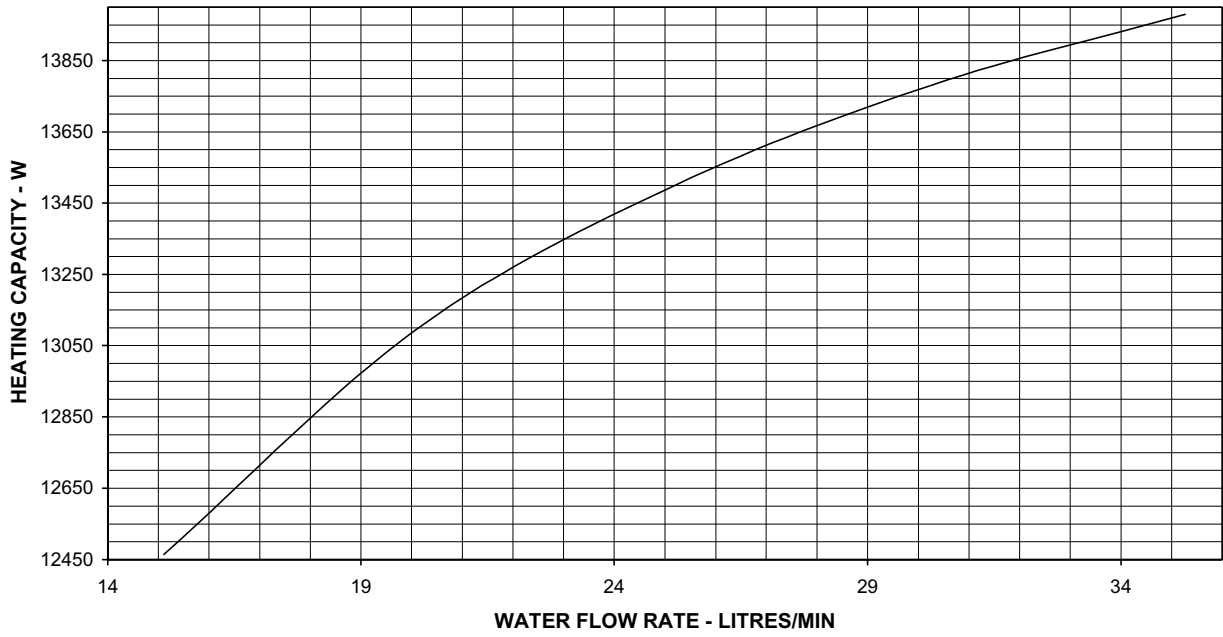

MCC040CW

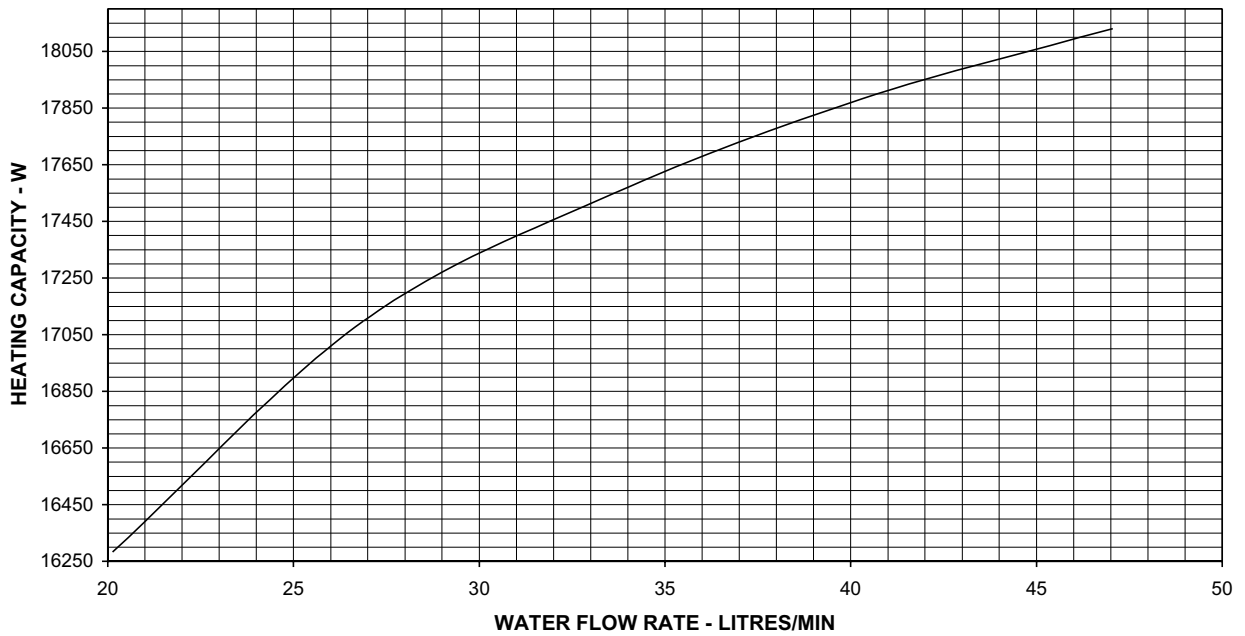

MCC050CW

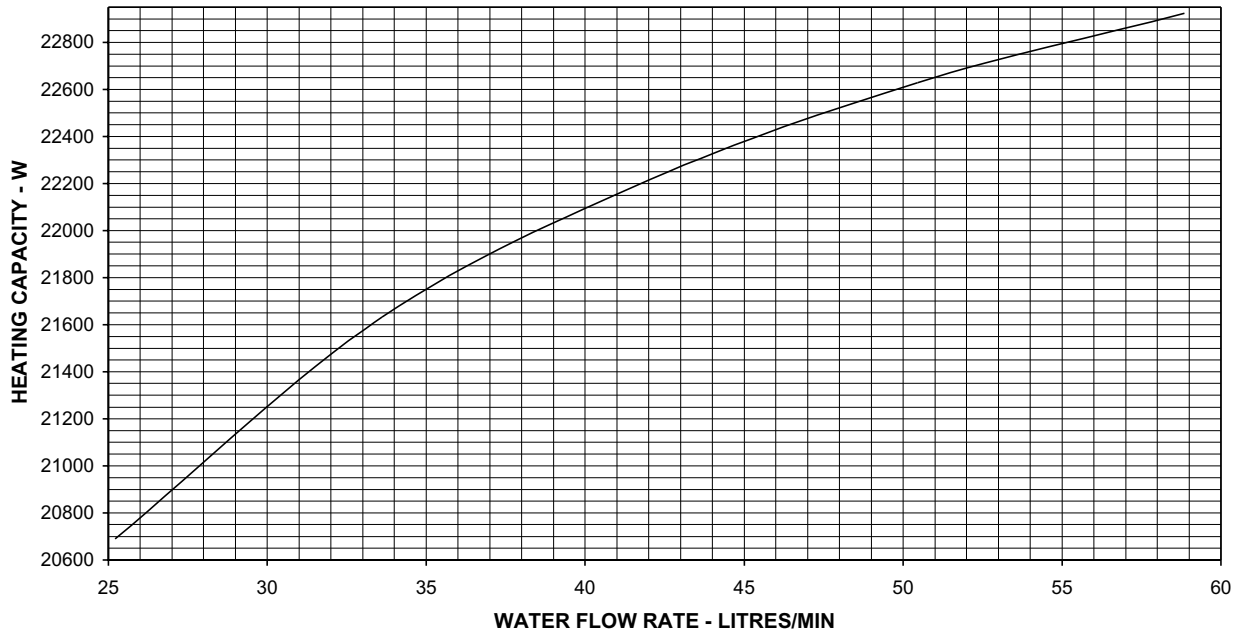

MCC060CW

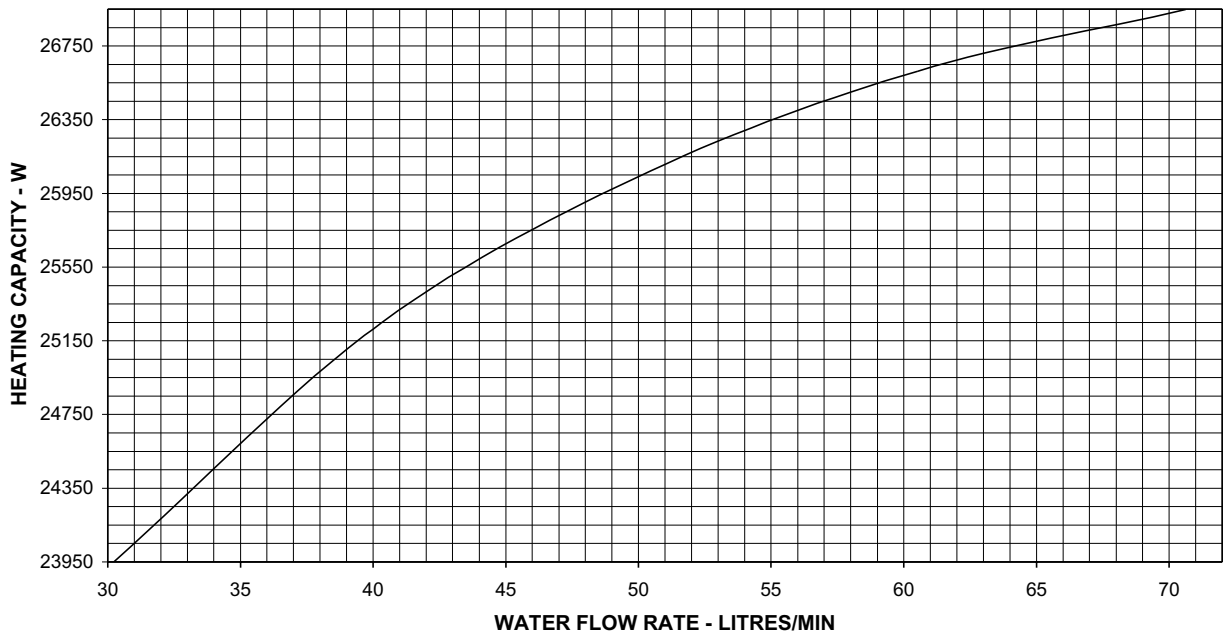

MCC028CW

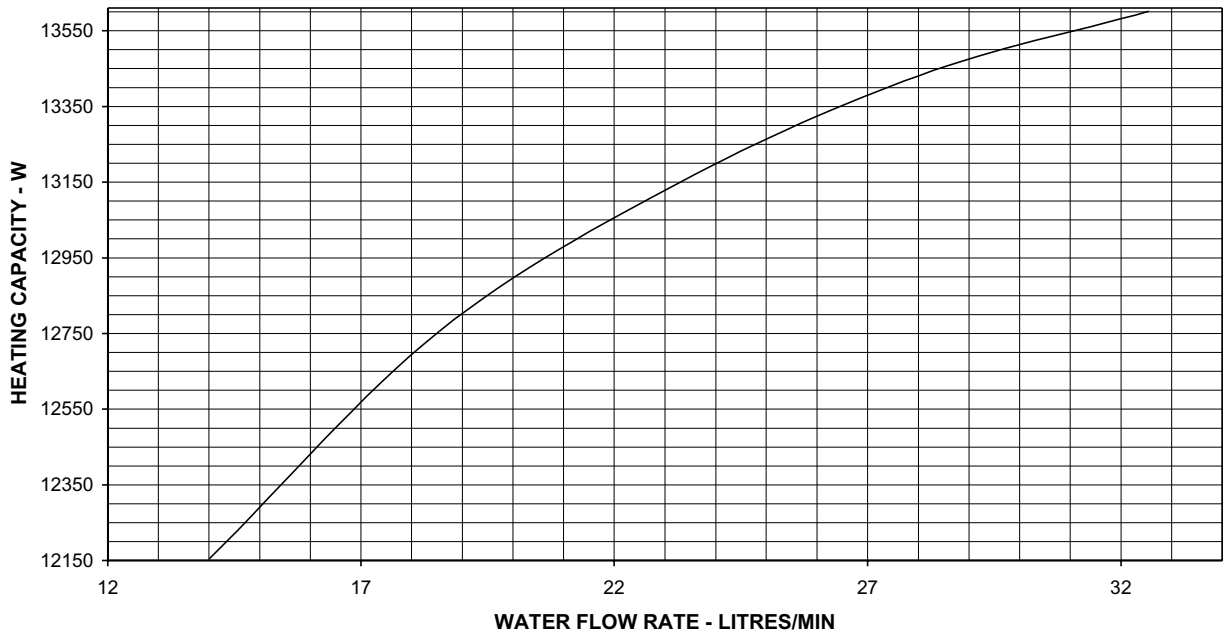

MCC038CW

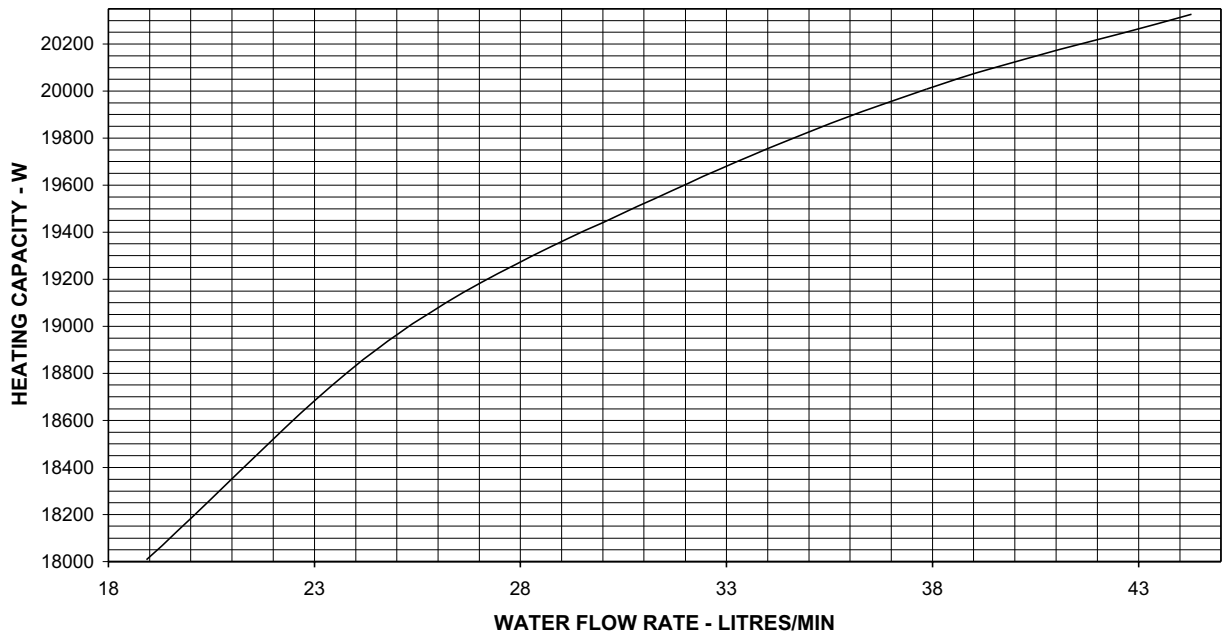

Ducted Blower Split Type

MDB075BW

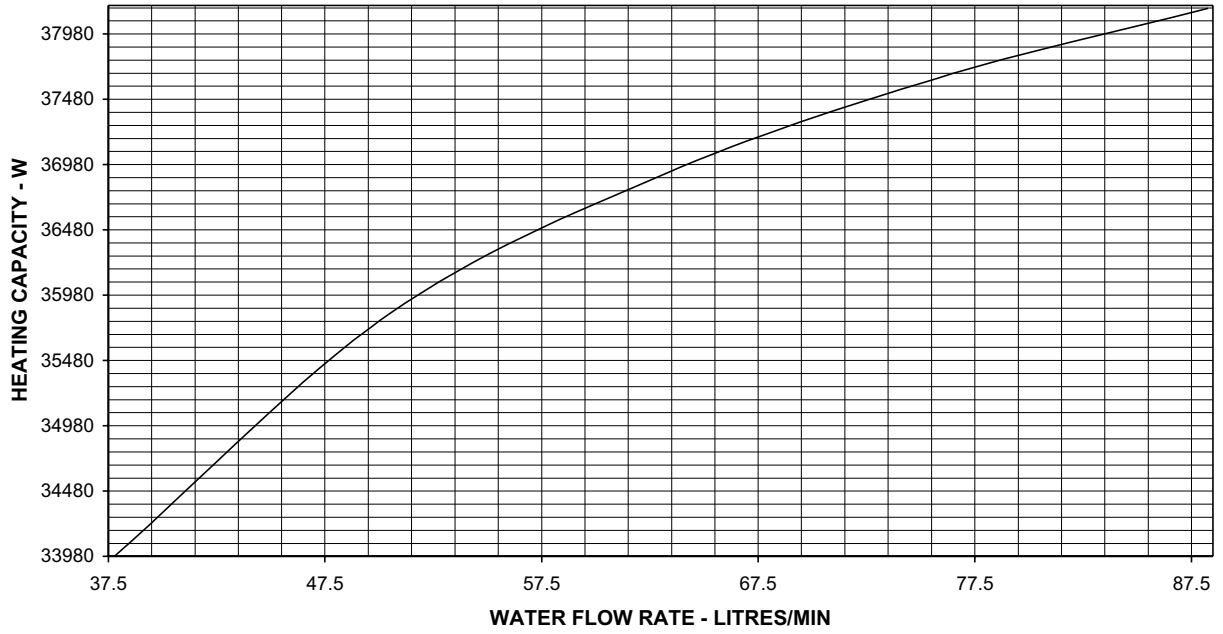

MDB100BW

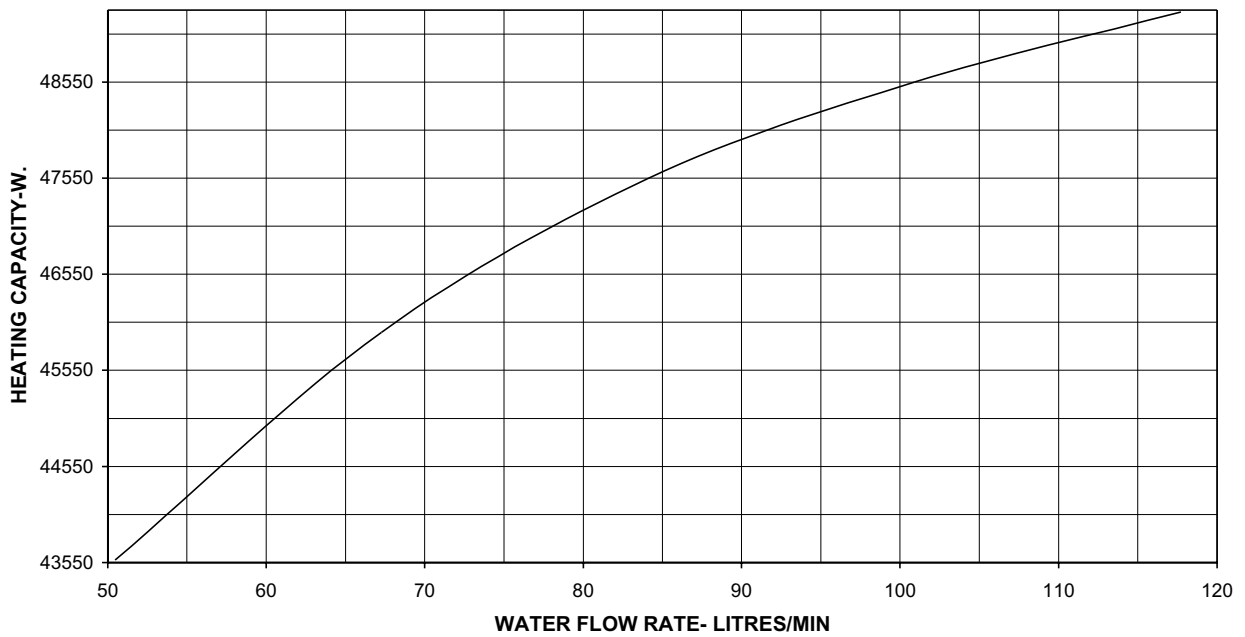

MDB125BW

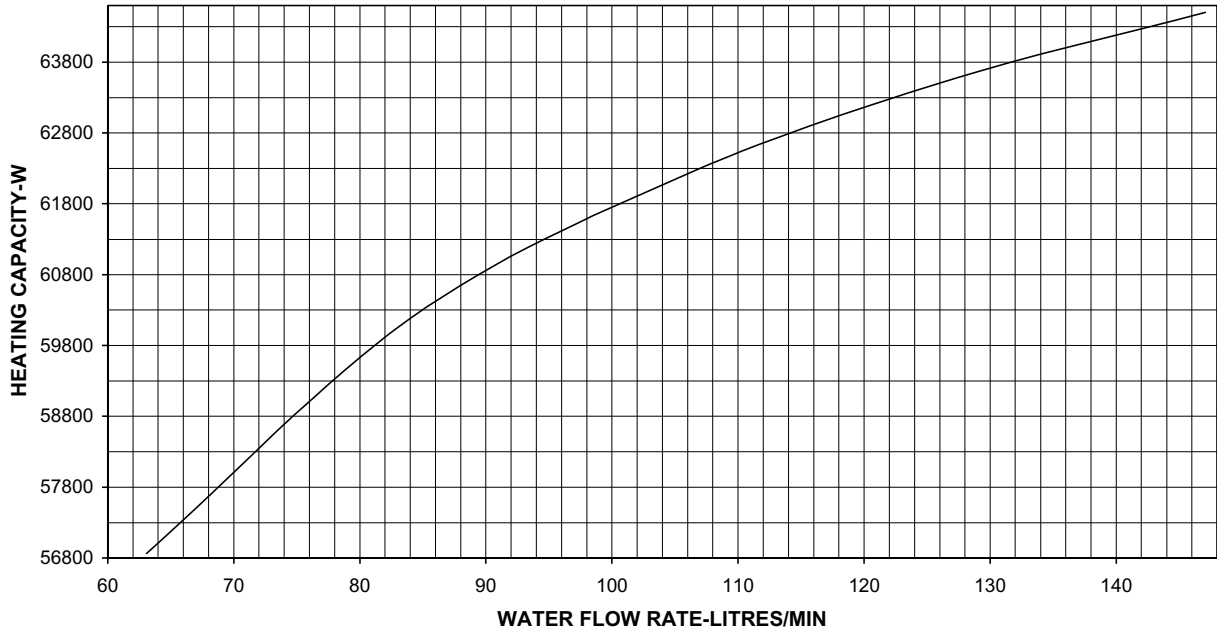

MDB150BW

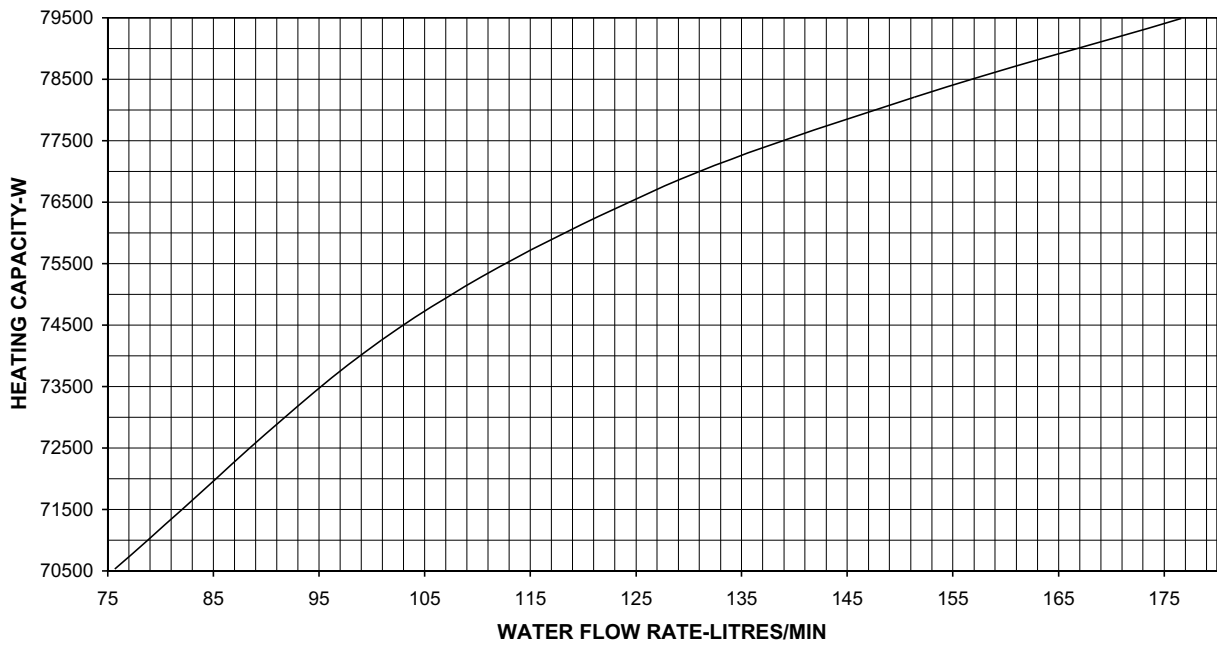

Water Flow Rate Vs Pressure Drop

Wall Mounted Type

MODELS	FLOW RATE		WATER PRESSURE DROP	
	LITRES / M	USGPM	kPa	PSI
MWM005FW	2.50	0.66	2.47	0.358
	3.33	0.88	4.04	0.586
	4.16	1.10	5.96	0.865
	5.00	1.32	8.20	1.190
	5.83	1.54	10.73	1.558
MWM007FW	3.48	0.92	4.36	0.632
	4.66	1.23	7.24	1.051
	5.83	1.54	10.73	1.558
	7.00	1.85	14.87	2.158
	8.18	2.16	19.70	2.860
MWM010FW	4.54	1.20	17.08	2.478
	6.06	1.60	28.26	4.101
	7.57	2.00	41.91	6.082
	9.08	2.40	58.37	8.472
	10.60	2.80	77.05	11.183
MWM015FW	6.06	1.60	28.29	4.106
	8.06	2.13	47.19	6.849
	10.11	2.67	70.77	10.272
	12.11	3.20	98.17	14.248
	14.12	3.73	129.72	18.828
MWM020FW	9.58	2.53	10.67	1.548
	12.76	3.37	17.65	2.562
	15.97	4.22	26.46	3.841
	19.15	5.06	36.65	5.320
	22.33	5.90	48.38	7.022
MWM025FW	12.07	3.19	16.05	2.330
	16.12	4.26	26.98	3.915
	20.17	5.33	40.30	5.850
	24.19	6.39	55.97	8.124
	28.24	7.46	74.17	10.765

Note :

a. PRESSURE DROP CORRECTION FACTOR = $1.2947 - 0.0021 * (EWT^{\circ}C * 1.8 + 32)$

b. PRESSURE DROP CORRECTION FACTOR = $1.2947 - 0.0021 * EWT^{\circ}F$

Ceiling Cassette Type

MODELS	FLOW RATE		WATER PRESSURE DROP	
	LITRES / M	USGPM	kPa	PSI
MCK020AW	10.07	2.66	4.69	0.681
	13.44	3.55	7.85	1.139
	16.81	4.44	11.71	1.700
	20.14	5.32	16.23	2.355
	23.50	6.21	21.50	3.120
MCK025AW	12.60	3.33	6.97	1.01
	16.81	4.44	11.72	1.70
	21.01	5.55	17.54	2.55
	25.21	6.66	24.44	3.55
	29.41	7.77	32.62	4.74
MCK030AW	15.10	3.99	9.70	1.41
	20.14	5.32	16.27	2.36
	25.21	6.66	24.46	3.55
	30.24	7.99	34.37	4.99
	35.28	9.32	45.70	6.63
MCK040AW	20.14	5.32	16.28	2.363
	26.87	7.10	27.51	3.993
	30.24	7.99	34.39	4.991
	33.61	8.88	41.80	6.067
	40.31	10.65	58.59	8.504
MCK050AW	21.01	5.55	17.58	2.552
	25.21	6.66	24.49	3.554
	29.41	7.77	32.67	4.742
	33.61	8.88	41.81	6.068
	42.05	11.11	63.42	9.204

MODELS	FLOW RATE		WATER PRESSURE DROP	
	LITRES / M	USGPM	kPa	PSI
MCK015BW	7.53	1.99	1.26	0.183
	10.07	2.66	2.09	0.304
	12.60	3.33	3.13	0.455
	15.10	3.99	4.33	0.628
	17.64	4.66	5.73	0.831
MCK020BW	10.07	2.66	4.02	0.58
	13.44	3.55	6.74	0.98
	16.81	4.44	10.07	1.46
	20.14	5.32	13.96	2.03
	23.50	6.21	18.31	2.66
MCK025BW	12.60	3.33	5.98	0.87
	16.81	4.44	10.07	1.46
	21.01	5.55	15.08	2.19
	25.21	6.66	21.04	3.05
	29.41	7.77	28.10	4.08
MCK030BW	15.10	3.99	8.32	1.208
	20.14	5.32	15.22	2.209
	25.21	6.66	21.05	3.055
	30.24	7.99	29.60	4.296
	35.28	9.32	39.37	5.714

Note :

- PRESSURE DROP CORRECTION FACTOR = $1.2947 - 0.0021 * (EWT^{\circ}C * 1.8 + 32)$
- PRESSURE DROP CORRECTION FACTOR = $1.2947 - 0.0021 * EWT^{\circ}F$

Ceiling Exposed Type

MODELS	FLOW RATE		WATER PRESSURE DROP	
	LITRES / M	USGPM	kPa	PSI
MCM020DW	10.07	2.66	6.70	0.973
	13.44	3.55	11.29	1.639
	16.81	4.44	16.91	2.455
	20.14	5.32	23.51	3.412
	23.50	6.21	31.42	4.560
MCM025DW	12.60	3.33	10.08	1.46
	16.81	4.44	16.93	2.46
	21.01	5.55	25.42	3.69
	25.21	6.66	35.77	5.19
	29.41	7.77	47.60	6.91
MCM030DW	15.10	3.99	9.33	1.35
	20.14	5.32	15.67	2.27
	25.21	6.66	23.58	3.42
	30.24	7.99	33.14	4.81
	35.28	9.32	44.08	6.40
MCM040DW	20.14	5.32	3.96	0.575
	26.87	7.10	6.64	0.963
	33.61	8.88	9.91	1.438
	40.31	10.65	13.75	1.996
	47.05	12.43	18.22	2.644
MCM050DW	25.21	6.66	5.89	0.855
	33.61	8.88	9.91	1.438
	42.05	11.11	14.85	2.156
	50.45	13.33	20.70	3.004
	58.86	15.55	27.57	4.001

Note :

- a. PRESSURE DROP CORRECTION FACTOR = $1.2947 - 0.0021 * (EWT^{\circ}C * 1.8 + 32)$
- b. PRESSURE DROP CORRECTION FACTOR = $1.2947 - 0.0021 * EWT^{\circ}F$

Cealing Concealed Type

MODELS	FLOW RATE		WATER PRESSURE DROP	
	LITRES/M	USGPM	kPa	PSI
MCC010CW	5.03	1.33	3.36	0.487
	6.70	1.77	5.54	0.804
	8.40	2.22	8.34	1.210
	10.07	2.66	11.53	1.674
	11.73	3.10	15.21	2.208
MCC015CW	7.53	1.99	7.61	1.10
	10.07	2.66	12.84	1.86
	12.60	3.33	19.27	2.80
	15.10	3.99	26.78	3.89
	17.64	4.66	35.82	5.20
MCC020CW	10.07	2.66	6.40	0.93
	13.44	3.55	10.78	1.57
	16.81	4.44	16.15	2.34
	20.14	5.32	22.45	3.26
	23.50	6.21	30.00	4.35
MCC025CW	12.60	3.33	10.46	1.518
	16.81	4.44	17.56	2.548
	21.01	5.55	26.35	3.825
	25.21	6.66	37.08	5.382
	29.41	7.77	49.35	7.162
MCC028CW	14.00	3.70	5.37	0.780
	18.55	4.90	8.91	1.293
	23.32	6.16	13.45	1.952
	28.01	7.40	18.76	2.723
	32.55	8.60	24.69	3.584
MCC030CW	15.10	3.99	4.60	0.668
	20.14	5.32	7.72	1.120
	25.21	6.66	11.55	1.677
	30.24	7.99	16.07	2.332
	35.28	9.32	21.27	3.087
MCC038CW	18.93	5.00	11.11	1.613
	24.98	6.60	18.31	2.658
	31.64	8.36	28.14	4.084
	37.85	10.00	39.35	5.711
	44.28	11.70	52.63	7.639
MCC040CW	20.14	5.32	8.36	1.213
	26.87	7.10	14.03	2.037
	33.61	8.88	21.06	3.057
	40.31	10.65	29.56	4.291
	47.05	12.43	39.34	5.709
MCC050CW	25.21	6.66	14.48	2.101
	33.61	8.88	24.36	3.535
	42.05	11.11	36.93	5.360
	50.45	13.33	51.73	7.508
	58.86	15.55	68.91	10.002
MCC060CW	30.24	7.99	3.23	0.469
	40.31	10.65	5.42	0.786
	50.45	13.33	8.10	1.175
	60.52	15.99	11.26	1.634
	70.63	18.66	14.92	2.165

Note :

- a. PRESSURE DROP CORRECTION FACTOR = $1.2947 - 0.0021 * (EWT^{\circ}C * 1.8 + 32)$
- b. PRESSURE DROP CORRECTION FACTOR = $1.2947 - 0.0021 * EWT^{\circ}F$

Ducted Blower Split Type

MODELS	FLOW RATE		WATER PRESSURE DROP	
	LITRES / M	USGPM	kPa	PSI
MDB075BW	37.81	9.99	19.50	2.830
	50.42	13.32	32.90	4.775
	63.06	16.66	50.00	7.257
	75.66	19.99	70.15	10.182
	88.27	23.32	93.60	13.585
MDB100BW	50.45	13.33	6.30	0.92
	67.26	17.77	10.55	1.53
	84.10	22.22	15.82	2.30
	100.91	26.66	22.21	3.22
	117.71	31.10	29.50	4.28
MDB125BW	63.06	16.66	7.65	1.11
	84.06	22.21	12.82	1.86
	105.11	27.77	19.24	2.79
	126.12	33.32	27.04	3.92
	147.12	38.87	35.95	5.22
MDB150BW	75.66	19.99	5.57	0.808
	100.91	26.66	9.36	1.358
	126.15	33.33	14.00	2.032
	151.36	39.99	19.50	2.830
	176.61	46.66	26.04	3.779

Note :

- a. PRESSURE DROP CORRECTION FACTOR = $1.2947 - 0.0021 * (EWT^{\circ}C * 1.8 + 32)$
- b. PRESSURE DROP CORRECTION FACTOR = $1.2947 - 0.0021 * EWT^{\circ}F$

Correction Factors

AIRFLOW CAPACITY CORRECTION FACTORS

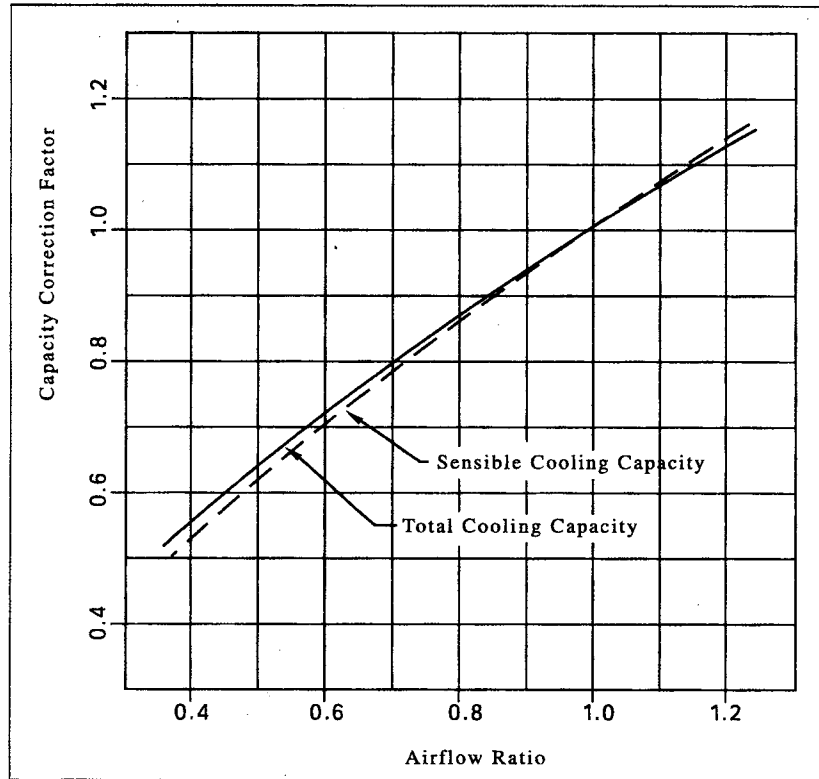

Water temperature rise is held as constant.

Altitude Correction Factors

Elevation, m	Total Capacity	Sensible Capacity
0	1.00	1.00
300	0.99	0.96
600	0.98	0.93
900	0.97	0.90
1200	0.96	0.86
1500	0.94	0.83
1800	0.93	0.80

Heating Capacity Correction Factors

EAT °C	ENTERING TEMPERATURE, °C										
	37.8	43.3	45.0	48.8	54.4	60.0	65.5	71.1	76.7	82.2	87.7
4.4	0.838	0.980	1.021	1.122	1.265	1.406	1.552	1.698	1.845	1.988	2.134
7.2	0.771	0.913	0.954	1.055	1.198	1.379	1.485	1.631	1.778	1.920	2.067
10.0	0.700	0.843	0.885	0.986	1.130	1.272	1.417	1.563	1.710	1.853	2.000
12.7	0.631	0.773	0.817	0.918	1.062	1.205	1.349	1.495	1.639	1.786	1.931
15.5	0.562	0.705	0.748	0.848	0.992	1.137	1.281	1.427	1.572	1.719	1.865
18.3	0.493	0.636	0.679	0.779	0.923	1.070	1.212	1.358	1.504	1.650	1.799
21.1	0.424	0.567	0.610	0.711	0.855	1.000	1.146	1.290	1.438	1.583	1.730
23.9	0.354	0.498	0.541	0.642	0.786	0.932	1.078	1.222	1.369	1.515	1.664
26.7	0.284	0.428	0.471	0.573	0.717	0.863	1.008	1.155	1.302	1.449	1.597

Notes : Adjusted capacity, W (@ Nominal air flow) = base heating capacity (@ nominal 60°C EWT, 21.1°C EAT) x Heating Capacity Correction Factor

Wiring Diagrams

Model : MWM 005 / 007 / 010 / 015FW (G6 CONTROLLER)

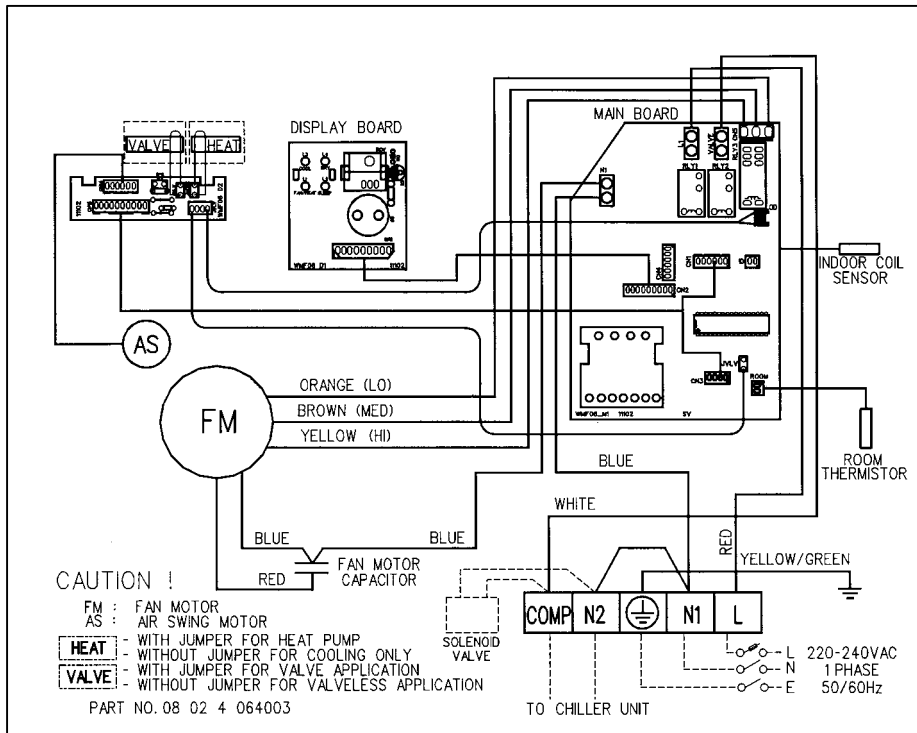

Model : MWM 005 / 007 / 010 / 015FW (NETWARE2 / SLM3 CONTROLLER)

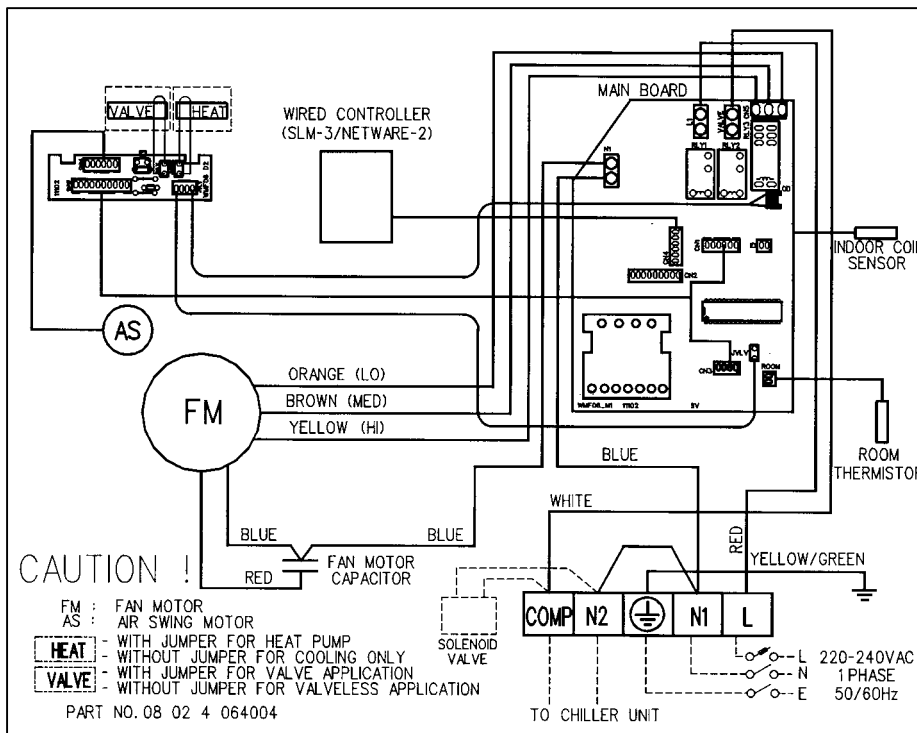

Model : MWM 020FW / 025FW (G6 CONTROLLER)

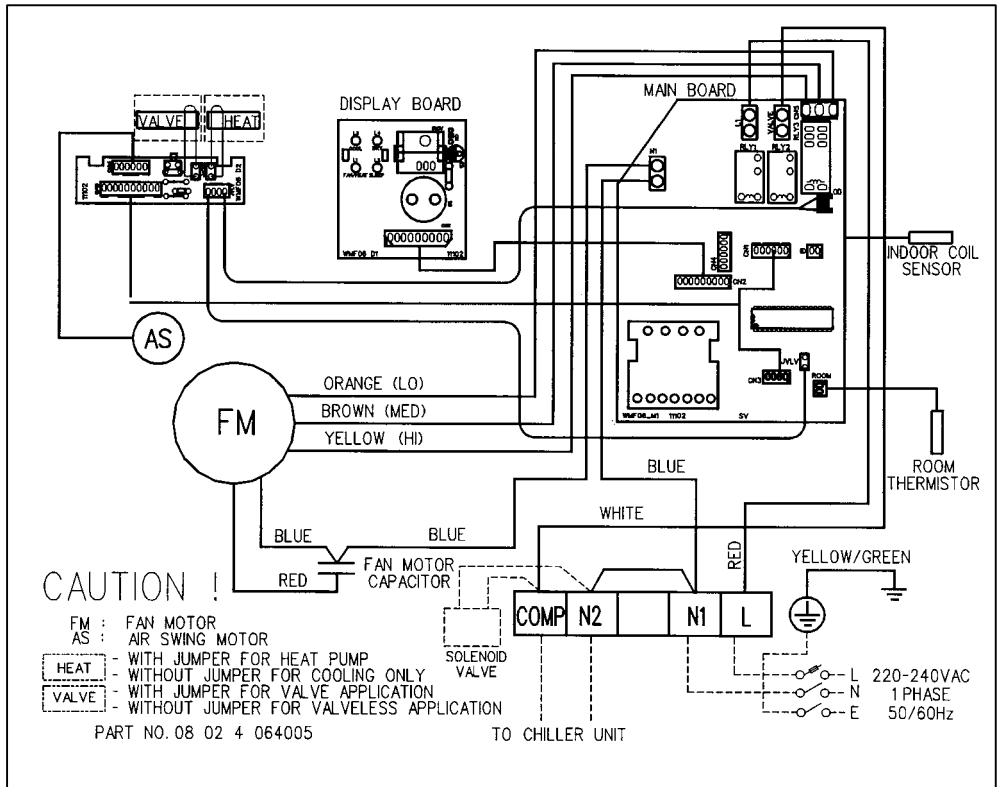

Model : MWM 020FW / 025FW (NETWARE2 /SLM3 CONTROLLER)

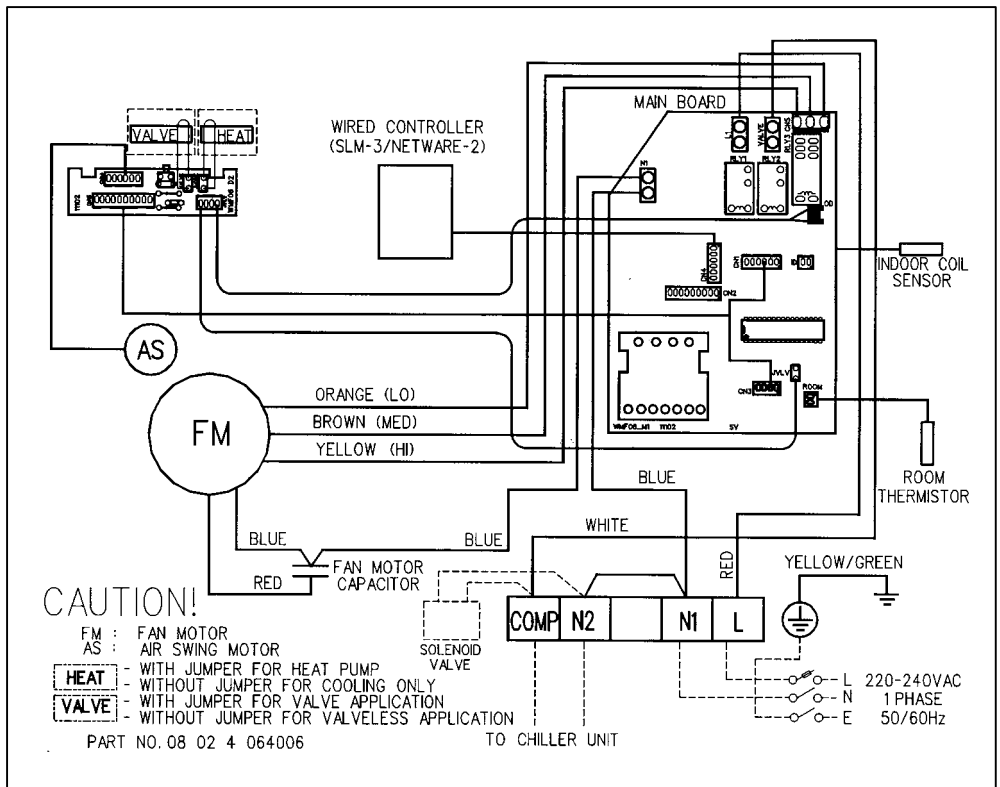

Model : MCK 020 / 025 / 030 / 040 / 050AW (G6, NETWARE2 OR SLM3 CONTROLLER)

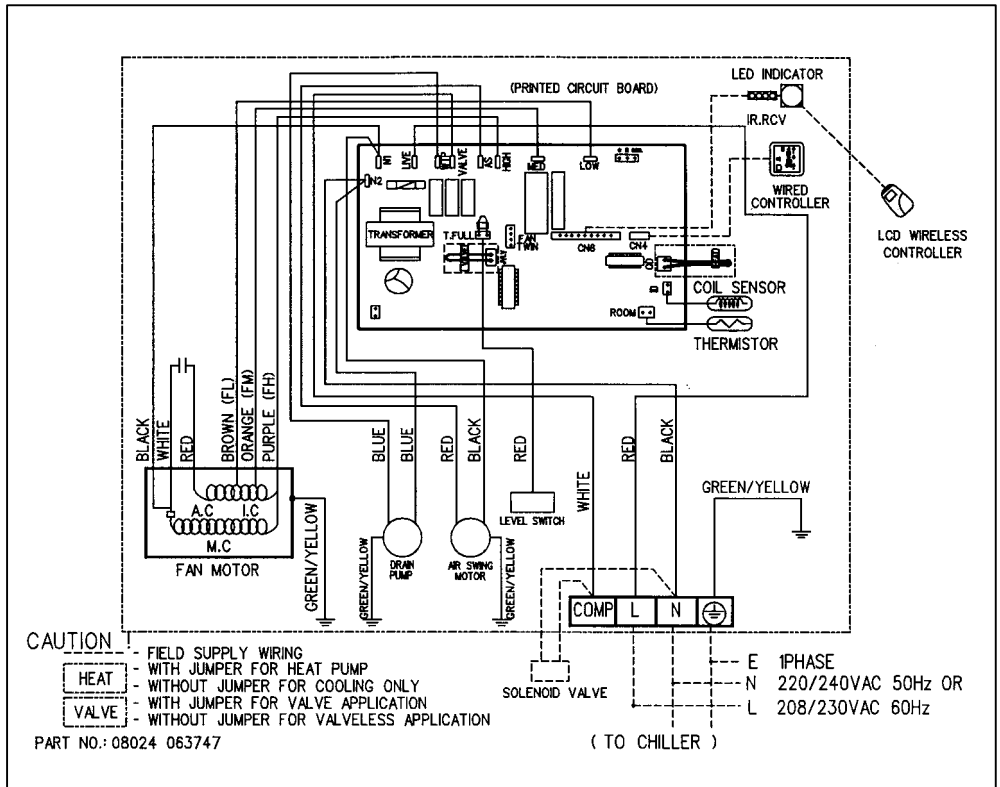

Model : MCK 015 / 020 / 025 / 030BW (G6, NETWARE2 OR SLM3 CONTROLLER)

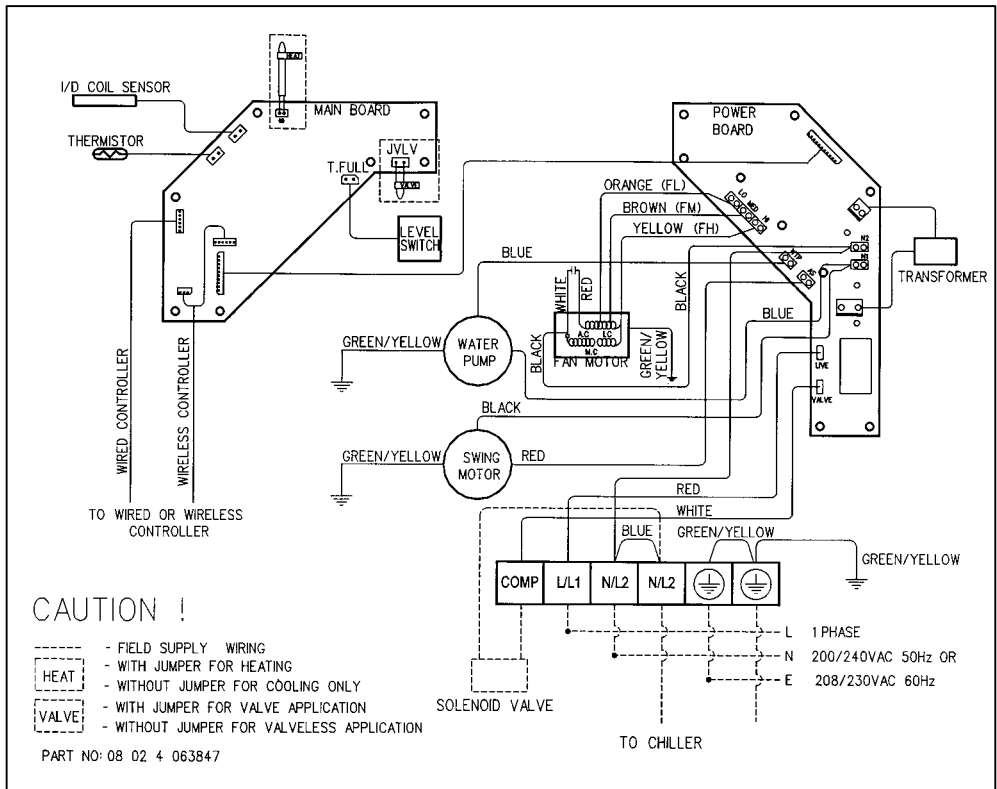

Model : MCM 020 / 025 / 030 / 040 / 050DW (G6, NETWORK2 OR SLM3 CONTROLLER)

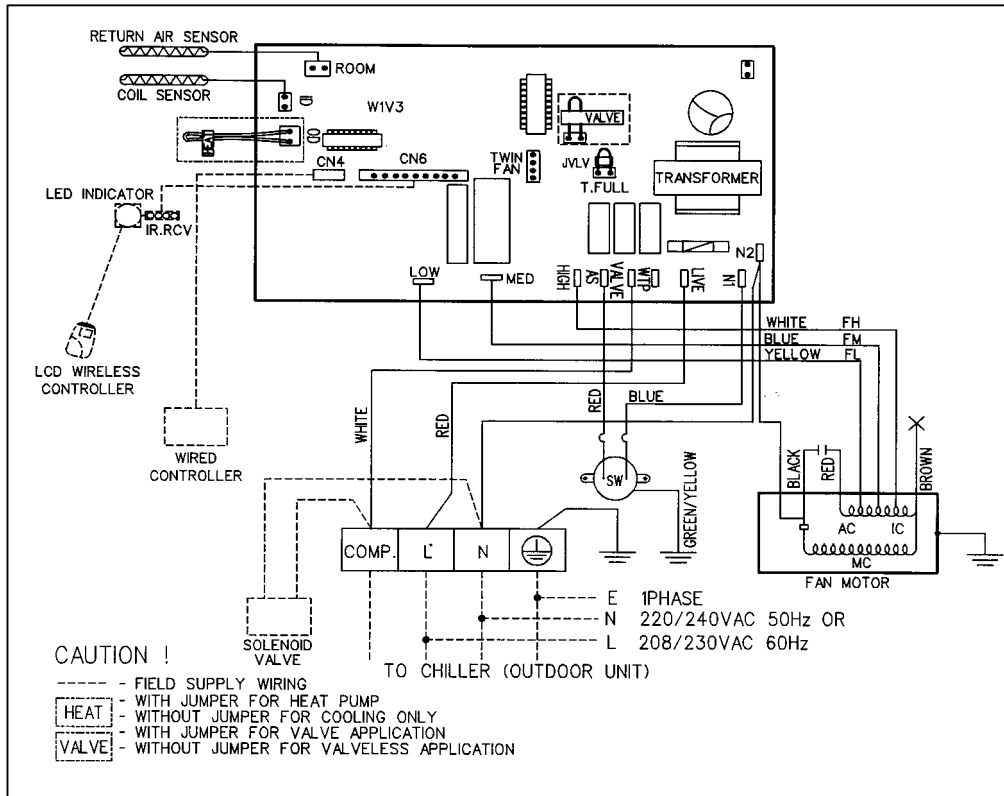

Model : MCC 010 / 015 / 020 / 025CW (NETWARE2 / SLM3 CONTROLLER)

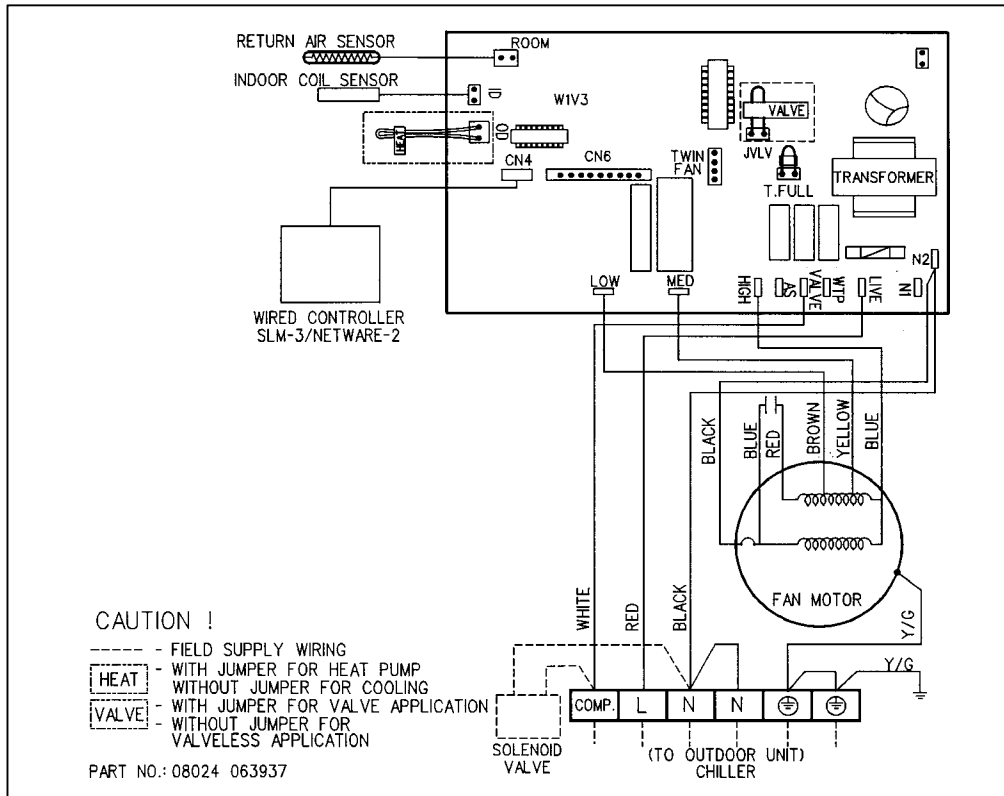

Model : MCC 028 / 030 / 038 / 040 / 050 / 060CW (NETWARE2 / SLM3 CONTROLLER)

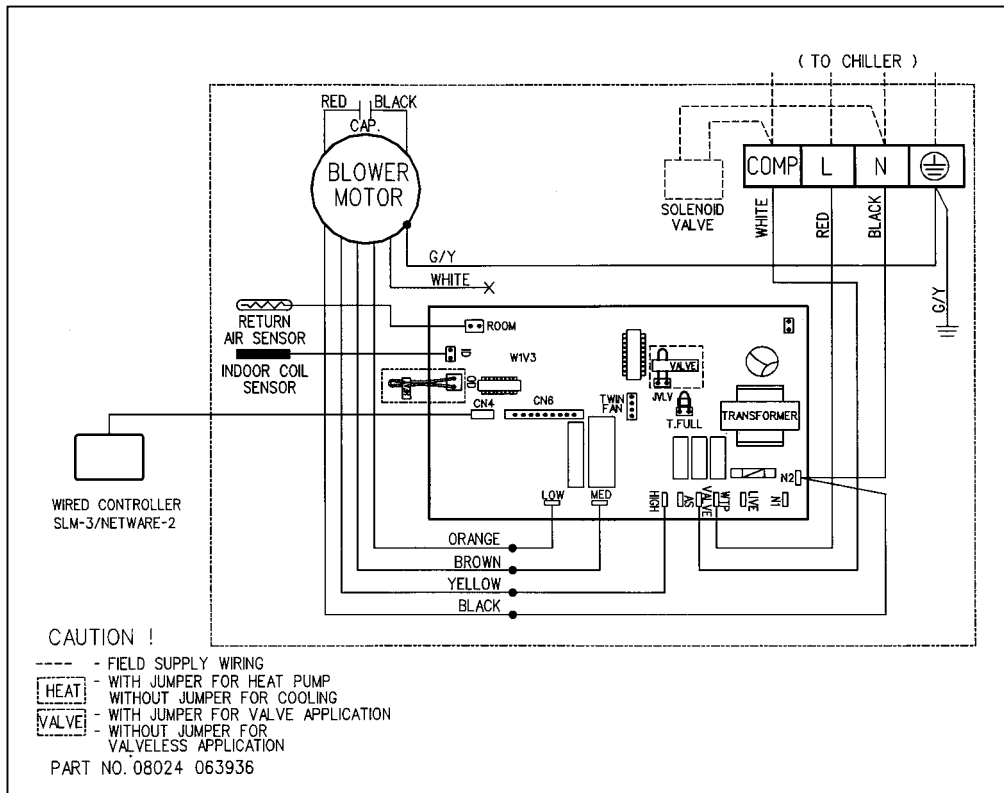

Model : MDB075/100BW - WITHOUT CONTROLLER

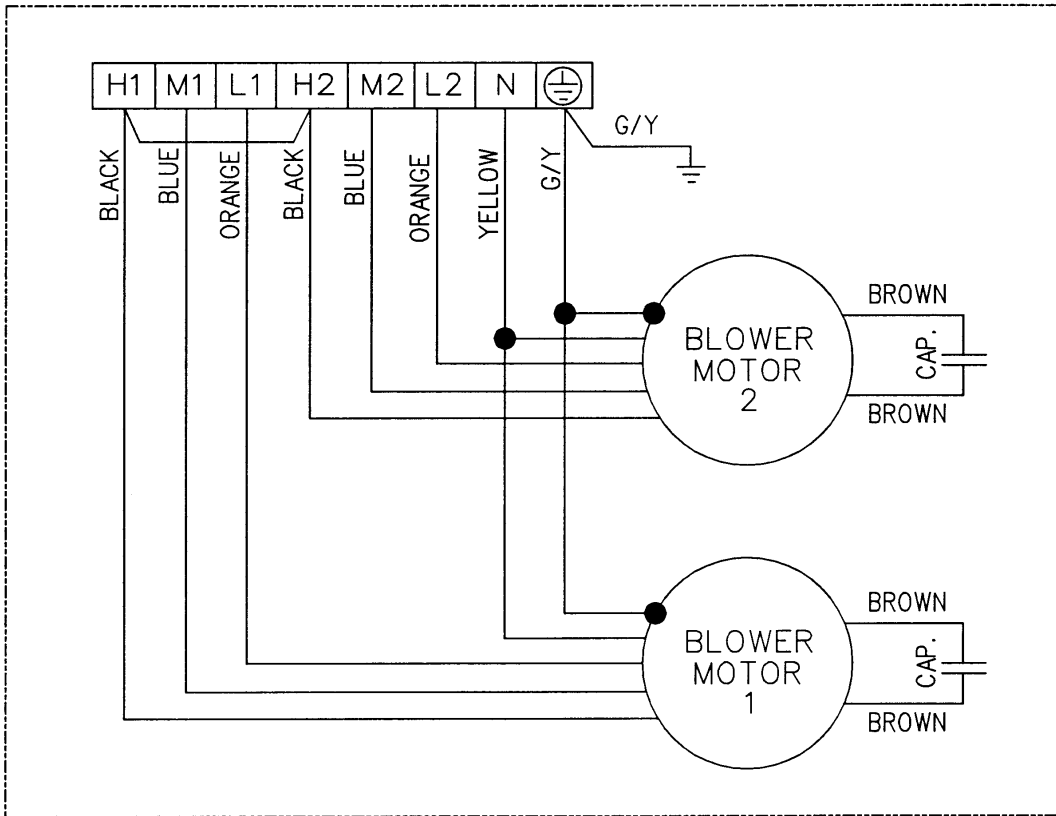

Model : MDB125/150BW - WITHOUT CONTROLLER

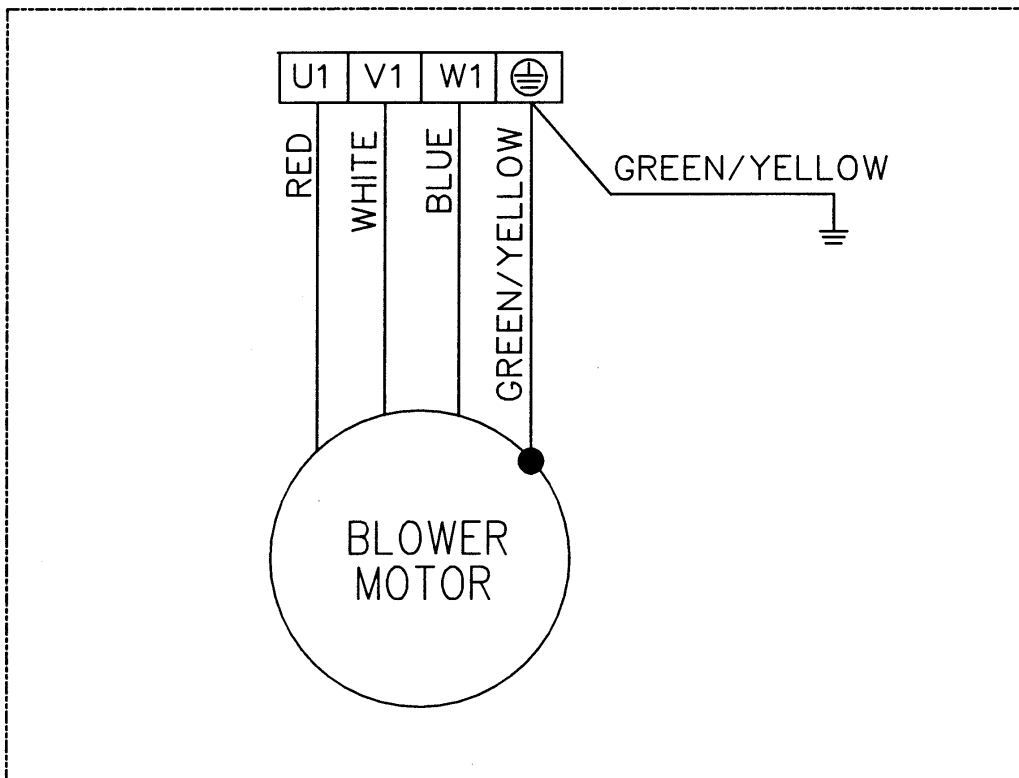

Controllers

Type Of Controller Vs Type Of Fan Coil

MODELS	STANDARD CONTROLLER	OPTIONAL CONTROLLER
MWM 005 – 025FW	G6 (Wireless)	NETWARE2 / SLM3 (Wired)
MCK 020 – 050AW	G6 (Wireless)	NETWARE2 / SLM3 (Wired)
MCK 015 – 030BW	G6 (Wireless)	NETWARE2 / SLM3 (Wired)
MCM 020 – 050DW	G6 (Wireless)	NETWARE2 / SLM3 (Wired)
MCC 010 – 060CW	NETWARE2 / SLM3 (Wired)	-
MDB 075 – 150BW	Without controller	

Self Diagnosis Table

Wireless		Wired	Operation / Faulty Indication
Power LED	Other LEDs	7 Segment Display	
Blinks 4 times	Fan blinks	E1 Blinking	Room sensor contact loose / short
Blinks 4 times	Sleep blinks	E2 Blinking	Indoor coil sensor contact loose / short
Blinks 1 time	Cool blinks	E4 Blinking	Pipe water temperature fault
Blinks 2 times	Cool & Fan blinks	E6 Blinking	Pump faulty

OPERATION GUIDE FOR G6

7 FAN SPEED AND VENTILATION MODE SELECTION

- Press the button until the desired fan speed is achieved.

8 SIGNAL TRANSMISSION INDICATION

- Blink to confirm the last setting has been send to the unit.

2 TEMPERATURE SETTING

- Set the desire room temperature.
- Press button to increase or decrease the set temperature. Setting range are between 16°C to 30°C setting (60°F to 80°F)(Optional setting from 20°C to 30°C).
- Press ▲ or ▼ button simultaneously will toggle the temperature setting between °C and °F.

6 OPERATION MODES

- Press the "mode" button for select the type of operating mode.
- Cooling only unit: Cool→Dry→Fan.
- Heating cycles: Cool→Dry →Fan→Heat.

5 TIMER SETTING

- Press set button to activate the timer setting (from 1 hour to 15 hour) of the air conditioning unit. It will be in "On" or "Off" condition after the set time depending to the current condition (either from "On" to Off or vise versa)
- To cancel the timer setting, press the button continuously until the timer display goes off.

4 SLEEP MODE

- Press the button to activate sleep mode. This mode can only be activated while in cooling or heating mode operation. If it is activated in "COOL" mode, the set temperature will be increase 0.5°C after 30 minutes, 1°C after 1 hour and 2°C after 2 hours.

1 ON / OFF switch

- Press to start the air conditioner unit.
- Press again to stop the unit.

3 AUTOMATIC AIR SWING

- Press the button to activate the automatic air swing function. The swing angle ranging from horizontal to 25° to bottom.

Netware2 Wired Controller

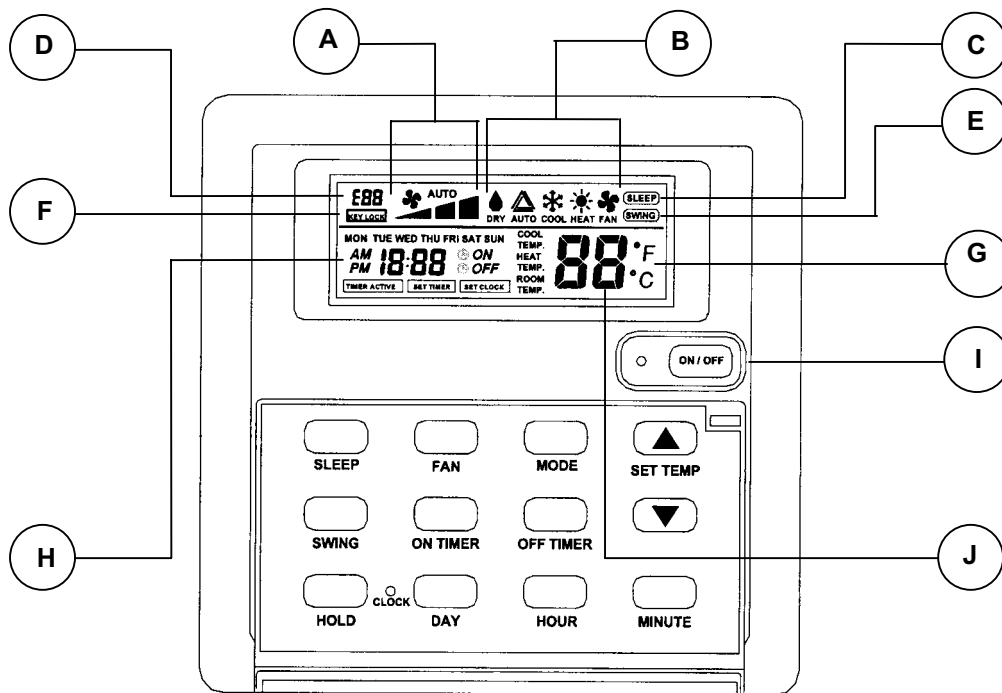

Display

A : Fan Speed Display

- Displays the fan speed setting (Auto/High/Medium/Low)

B : Operation Mode Display

- Displays the current mode of operation.

C : Sleep Display

- Display the sleep / energy saving status.

D : Error Display

E : Swing Display

- Display the air swing status.

F : Key Lock Display

- Display indicates when key lock function is activated.

G : °C or °F Display

- Display the temperature in °C or °F.

H : Current Time Start / Stop Time Display

- Display the current time as well as the start and stop time programmed.

I : On / Off Status Lamp Display

J : Set Temperature or Room Temperature Display

- Display the set or room temperature.

Other functions

- Last state memory using battery back up.

For 7-days programmable time option, battery back up is used to retain the last state data.

Units without battery back up will depend on the EEPROM on the main board.

- Error Indicator

Error code will be shown for any abnormal condition detected.

Refer to main board error codes for detail.

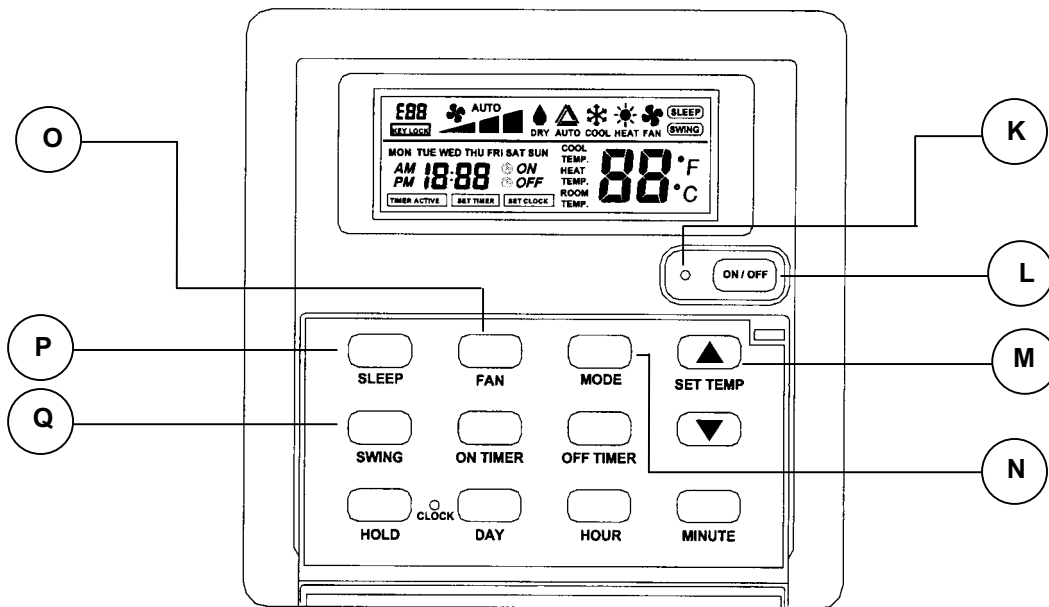

Operation

K : Operating Lamp

L : On / Off

- *Starting operation :*
When the unit is off, press the ON/OFF button. The operation LED lights and the unit will be turned on.
- *Stopping operation :*
When the unit is on, press the ON/OFF button. The operation LED is extinguished and controls are turned off.

M : Set Temperature

- Press this button to set the temperature. By pressing up or down once, temperature changes by 1°C (or 1°F).
- The temperature range is 16°C to 30°C (60°F to 85°F).
- In FAN mode, temperature can not be set.
- Pressing up and down buttons simultaneously will toggle the temperature unit between °C and °F.
- When set temperature button is pressed, the set temperature will be displayed for 5 seconds. After that, room temperature will be displayed.

N : Mode

- Press MODE button to select operation mode from Cool, Heat, Dry and Fan. The display will show the selected mode.

O : Fan

- Press FAN button to select Auto, High, Medium or Low fan speed.

P : Swing

- Press SWING button to activate the air sweep function.

Q : Sleep

- Press SLEEP button to activate the sleep or energy saving mode.

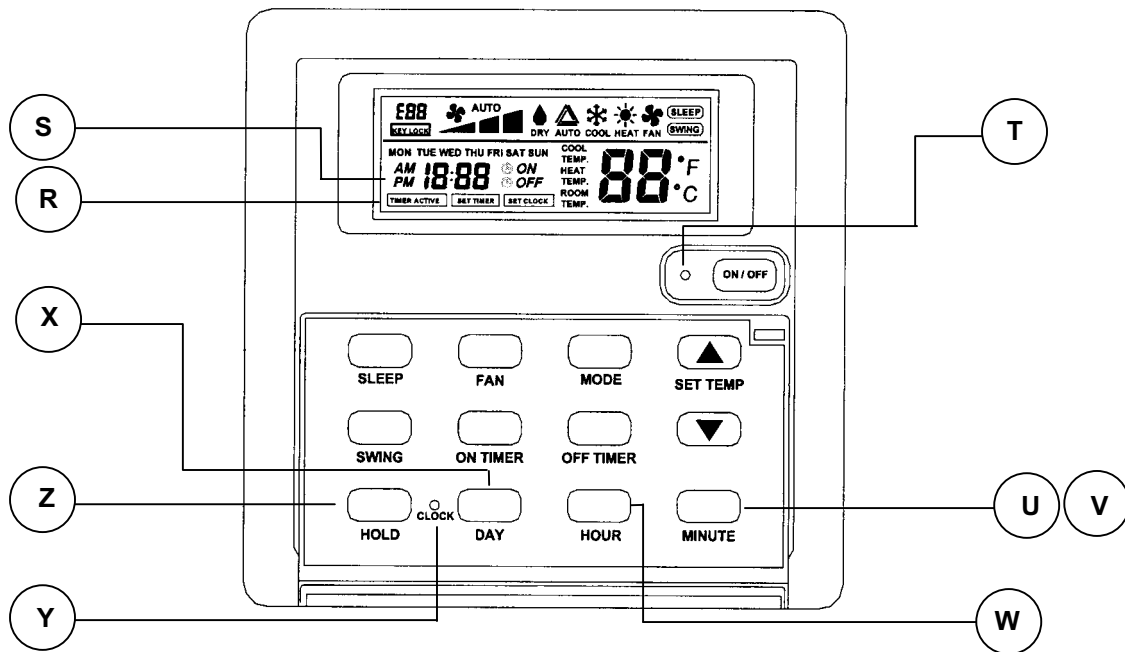

R : Timer Hold / Resume Display

S : Current Time Display

T : Operating Lamp

U : Key Lock

- This feature protects the controls from being tampered with by children or unauthorized persons.
- To activate, press the MINUTE button three times consecutively. 'KEY LOCK' symbol will appear on the LCD display.
- During this time, ON/OFF button and FAN button can be used.
- To cancel this feature, press the MINUTE button again three times consecutively.

V : Minute

- When the control is in set clock or set timer mode, pressing the HOUR button will change the set hour.

W : Hour

- When the control is in set clock or set timer mode, pressing the HOUR button will change the set hour.

X : Day

- When the control is in set clock or set timer mode, pressing the DAY button will change the set day.

Y : Clock

- Press button once to set the clock mode.
- Press button again to disable the clock mode.
- When the clock mode is activated, the time and date can be set or changed by pressing the DAY, HOUR or MINUTE buttons.

Z : Timer Hold / Resume

- If 7-days timer is set, the word 'TIMER ACTIVE' is displayed.
- To clear the timer setting, press and hold the HOLD button for 2 to 3 seconds until the word 'TIMER ACTIVE' is no longer displayed.
- To resume the timer setting after the timer has been placed on hold, press and hold the HOLD button again for 2 to 3 seconds until the word 'TIMER ACTIVE' is displayed.

SLM3 Wired Controller

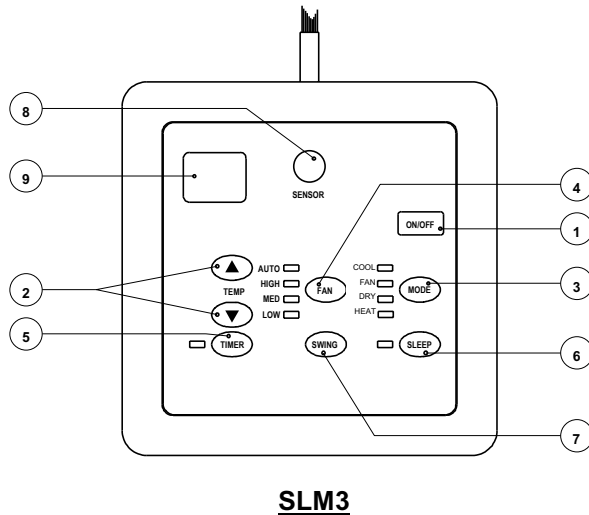

SLM3

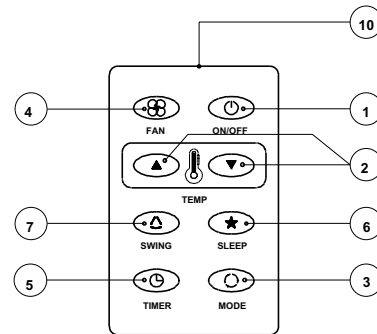

AC5300 (OPTIONAL)

1. "ON/OFF" switch

- Press to start the air conditioner unit.
- Press again to stop the unit.

2. Temperature setting

- Set the desired room temperature.
- Press button to increase or decrease the set temperature. Setting range are between 16°C to 30°C (60°F to 80°F).

3. Operation Modes

- Press the "mode" button for select the type of operating mode.
 - Cooling Only : COOL, FAN, DRY
 - Heat Pump : COOL, FAN, DRY, HEAT

4. Fan Speed selection.

- Press the button until the desired fan speed is achieved.

5. Timer.

- Press the set button to select the switch timer of the air conditioner unit (the setting range is between 1 to 15 hours).

6. "Sleep" mode

- Press button to activate the sleep function. This function can only be activated under "cool" or heating mode operation. When it is activated under "cool" mode operation, the set temperature will increase 0.5°C after 30 minutes, 1°C after 1 hour and 2°C after 2 hours. If it is activated under "HEAT" mode operation, the set temperature will be decreased 0.5° C after 30 minutes, 1° C after 1 hour and 2° C after 2 hours.

7. Air Swing

- Press button to activate the automatic air swing function.

8. Sensor

- Infra red sensor to receive signals from wireless controller.

9. LED display

- To display the set temperature (in ° C) and timer delay setting (in hours).

10. Transmission source

- To transmit signals to the air conditioner.

Installation Of LCD Remote Controller

Step-By-Step Guide

- i) First, open up the casing of the LCD remote controller into its top and bottom case using a screwdriver. To do this, insert the screwdriver into the lower slot and slide it in the outward direction.
- ii) Fix the bottom case onto the wall with the 2 wooden screws provided. Then, insert the 4 connecting wires (from the main board) through the slot on the lower center of the case as shown below.
- iii) Connect one end in each of the 3 wires to the terminal block behind the top case as illustrated.
- iv) To select cooling only model or heatpump model, some adjustment required in the dip switch setting.
- v) Fasten back the top and bottom case into place. Hook the two upper claws into their respective slots and snap the lower part shut.

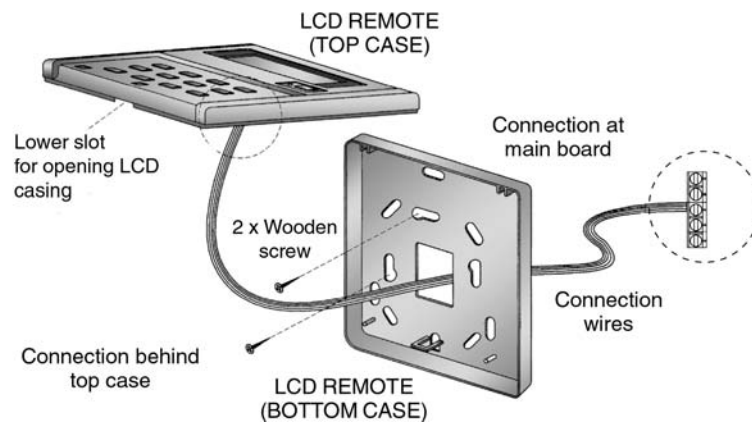

Dip switch setting for model selection

Pin	Function	Remarks
JH & JD	RESERVE	JH-OFF, JD-OFF
	COOL, DRY, FAN	JH-OFF, JD-ON
	COOL, DRY, FAN, HEAT	JH-ON, JD-OFF
RTC	NO REAL TIME CLOCK	RTC-OFF
	REAL TIME CLOCK	RTC-ON
NO DRY	WITHOUT DRY FUNCTION	NO DRY-ON
	DRY FUNCTION	NO DRY-OFF

Blower Performance Curves

BLOWER PERFORMANCE CURVE
MCC 010CW

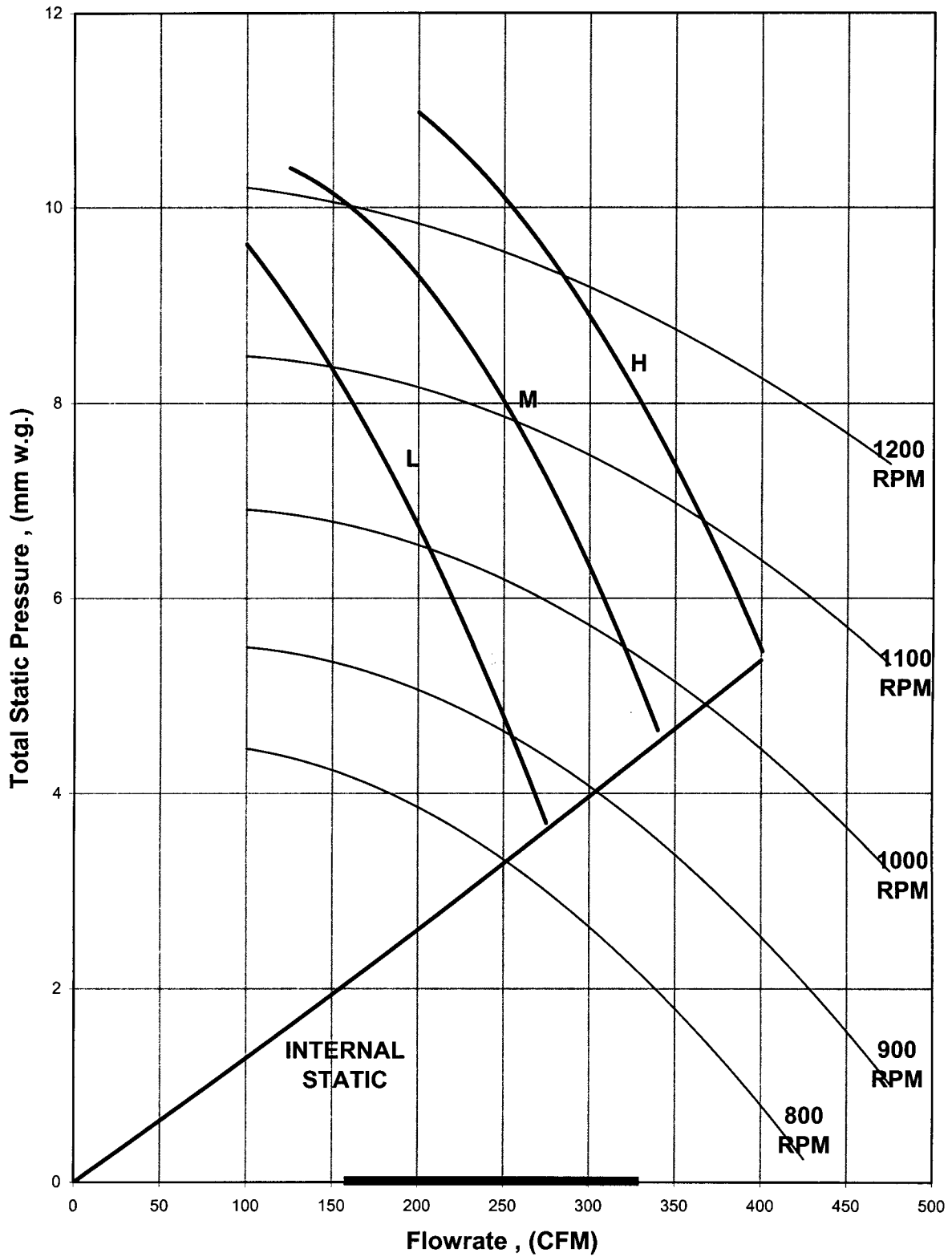

BLOWER PERFORMANCE CURVE MCC 015CW

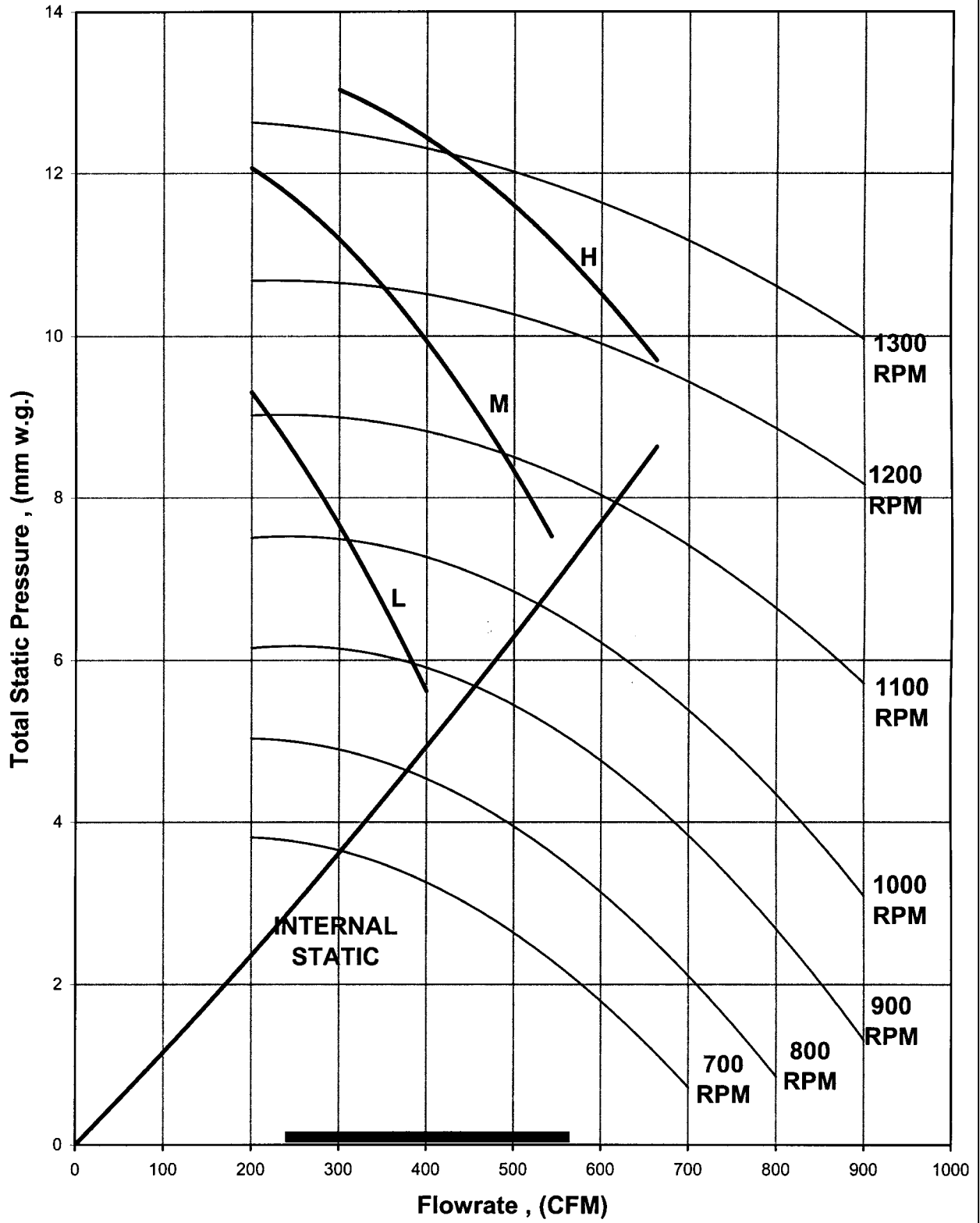

BLOWER PERFORMANCE CURVE MCC 020W

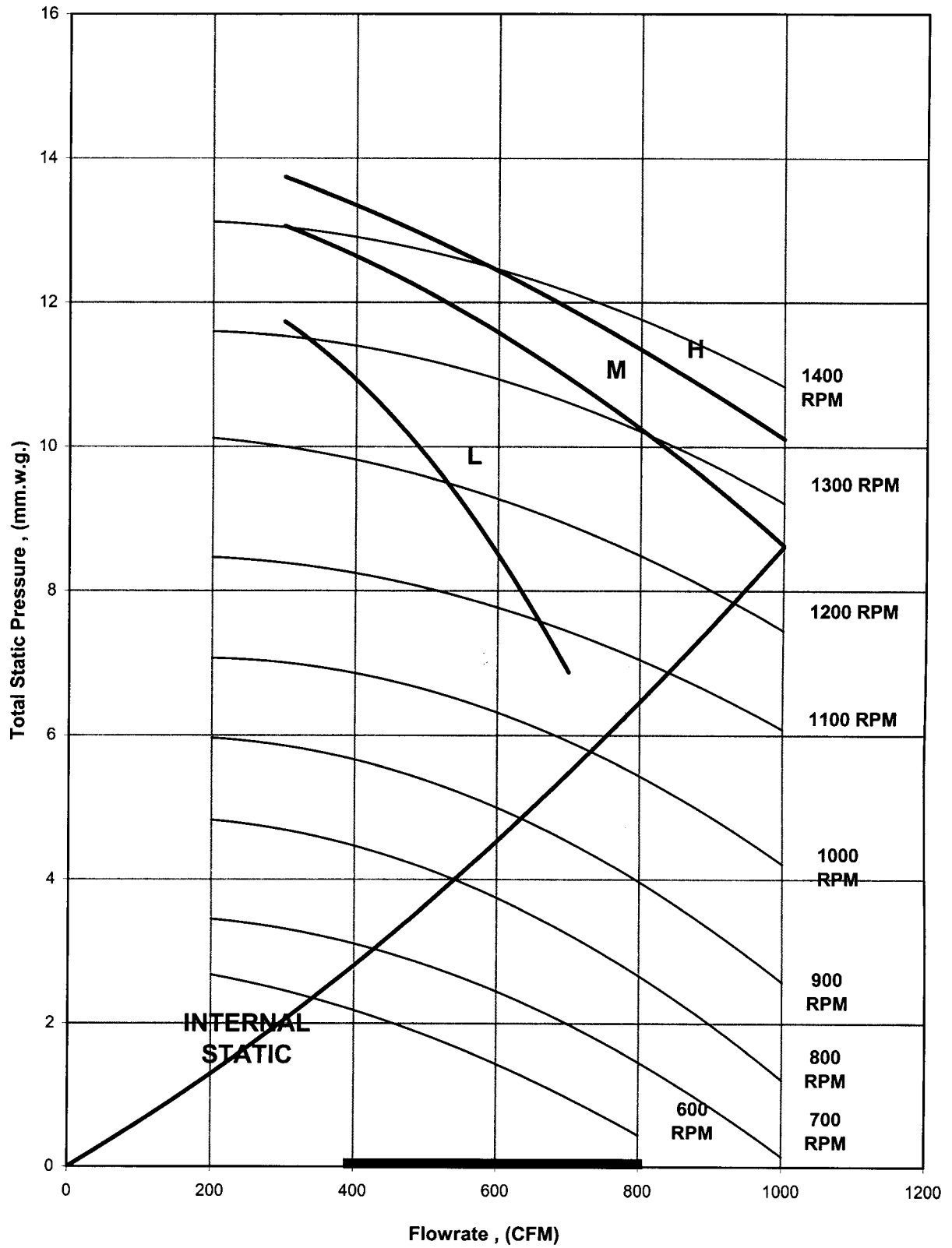

BLOWER PERFORMANCE CURVE MCC 025CW

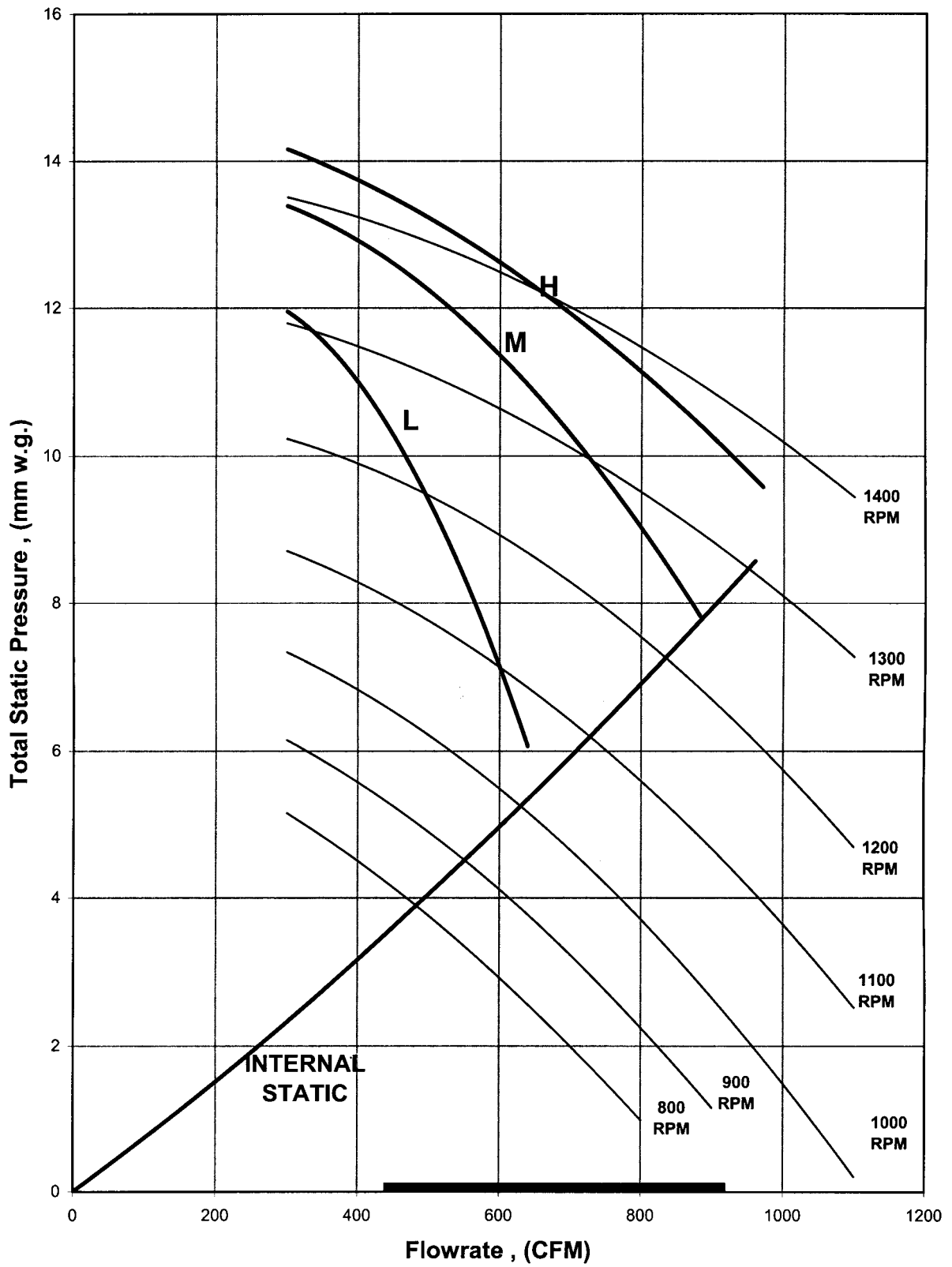

BLOWER PERFORMANCE CURVE MCC 028CW

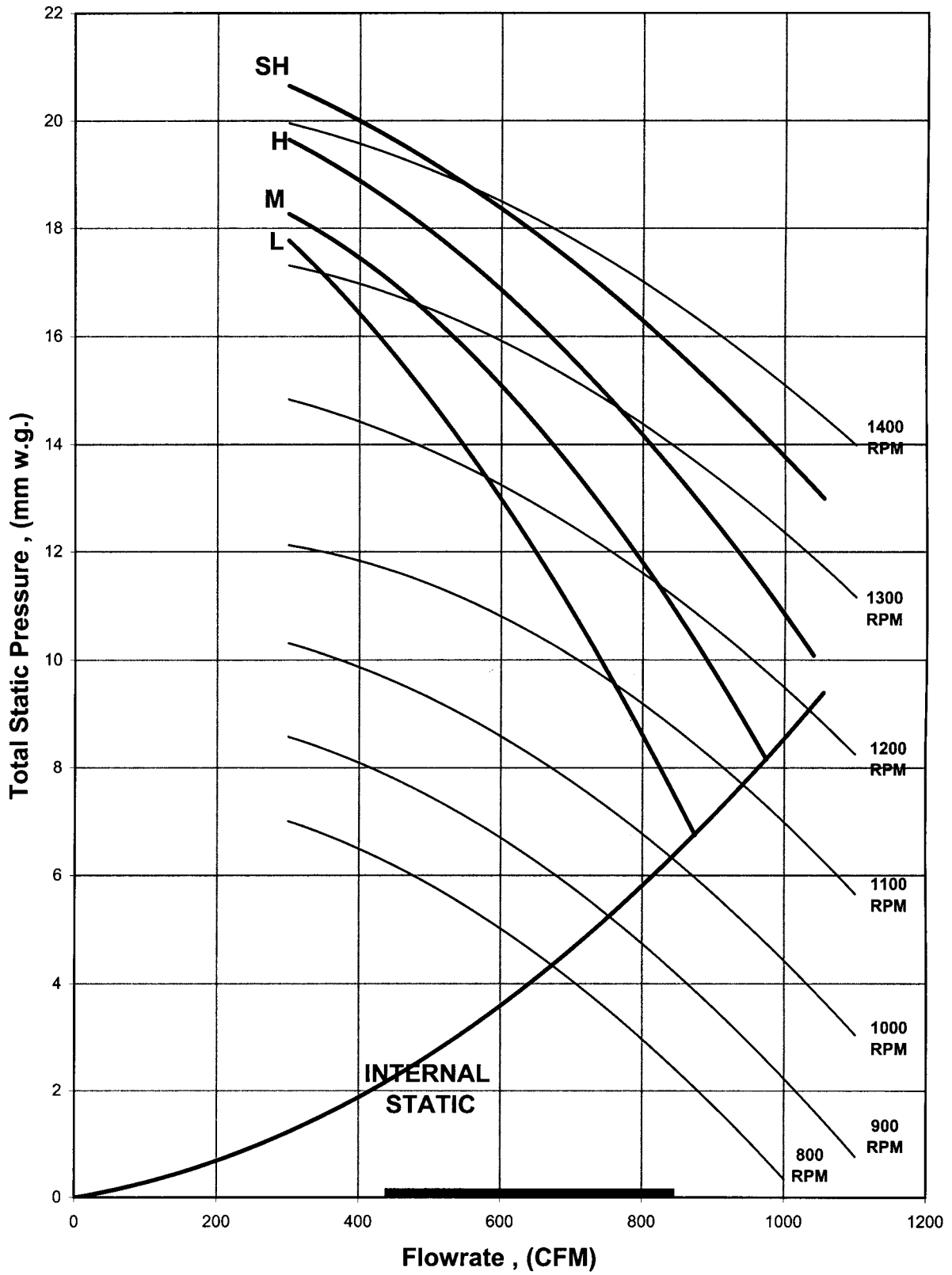

BLOWER PERFORMANCE CURVE MCC 030CW

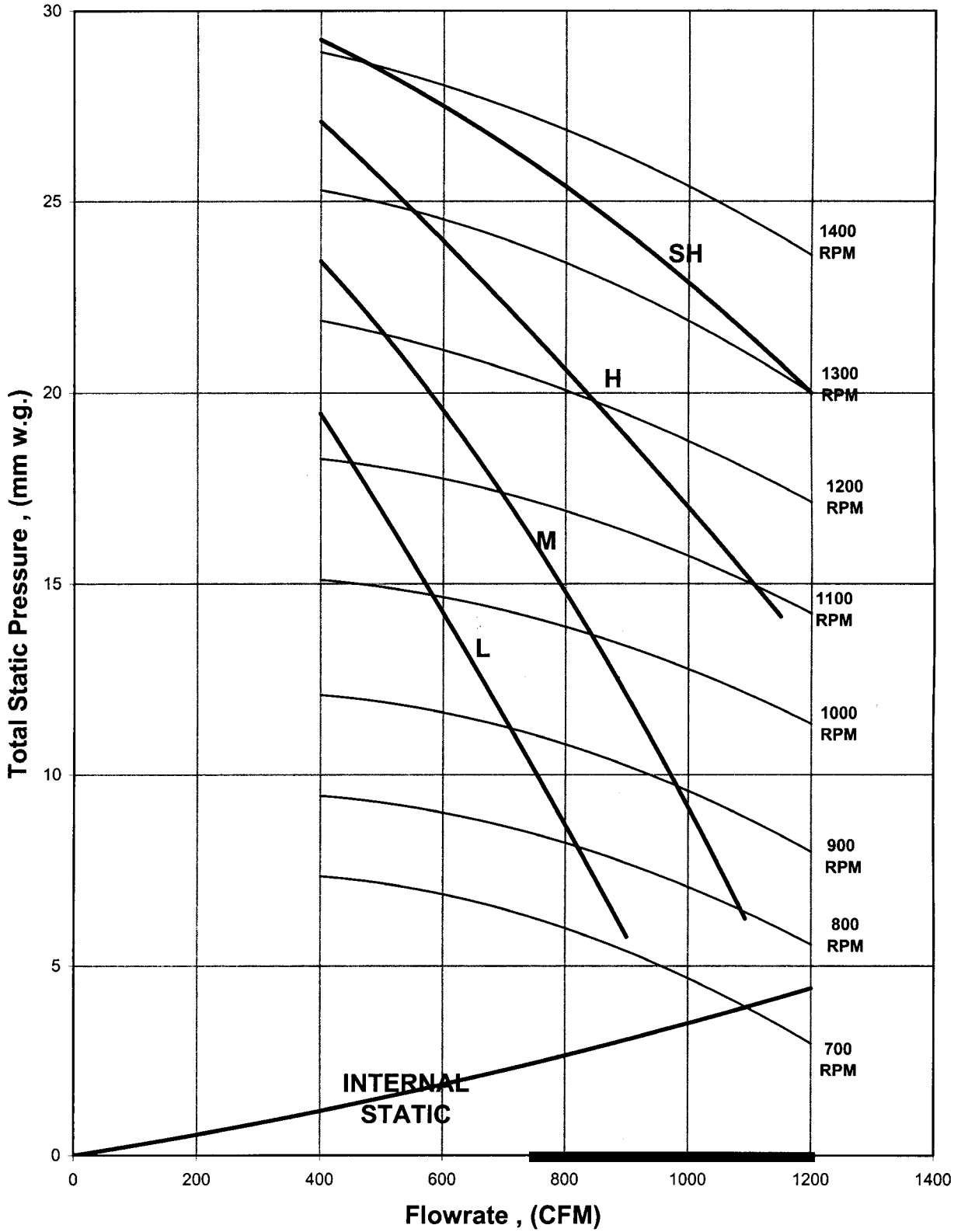

BLOWER PERFORMANCE CURVE MCC 038CW

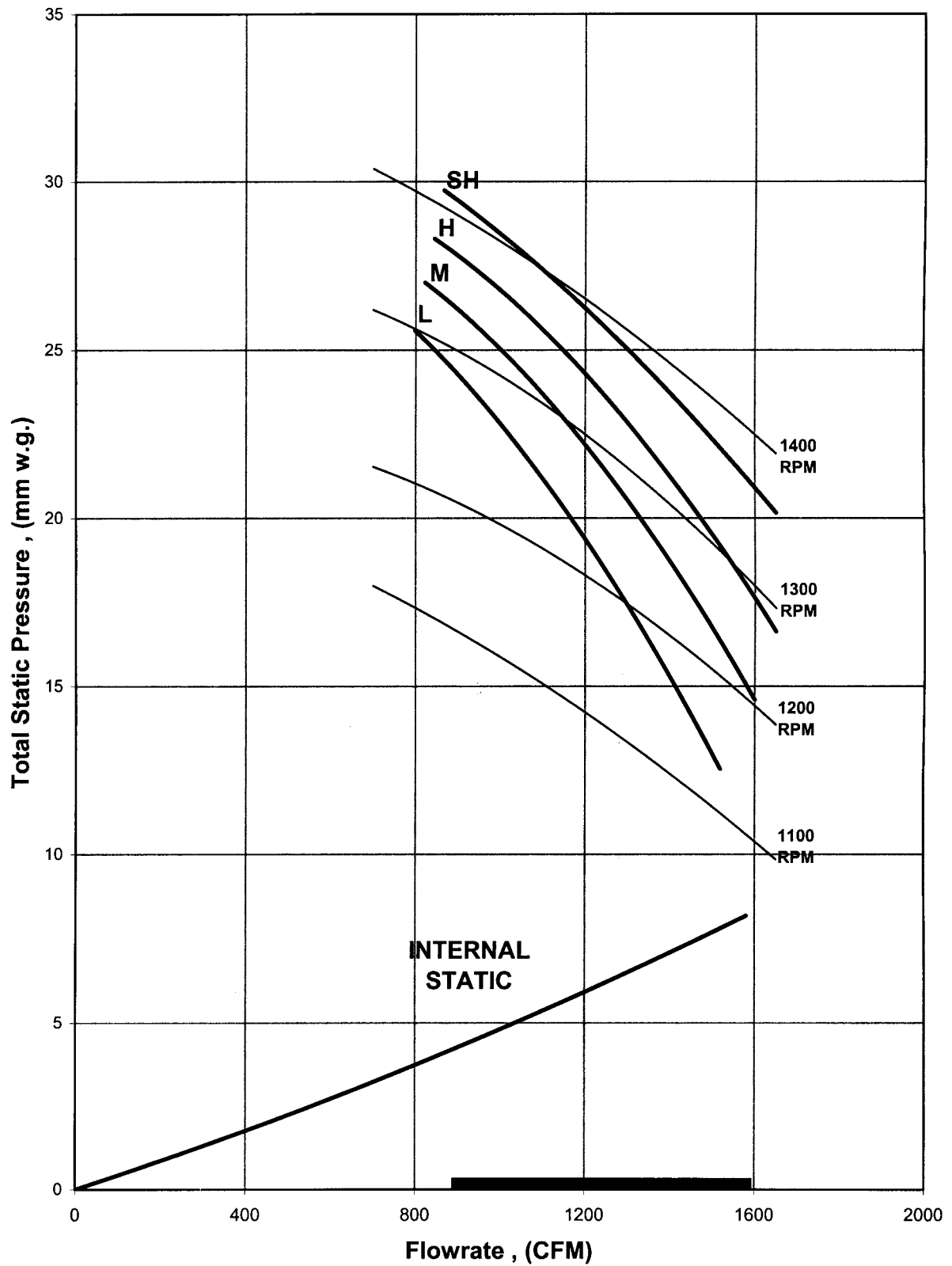

BLOWER PERFORMANCE CURVE MCC 040CW

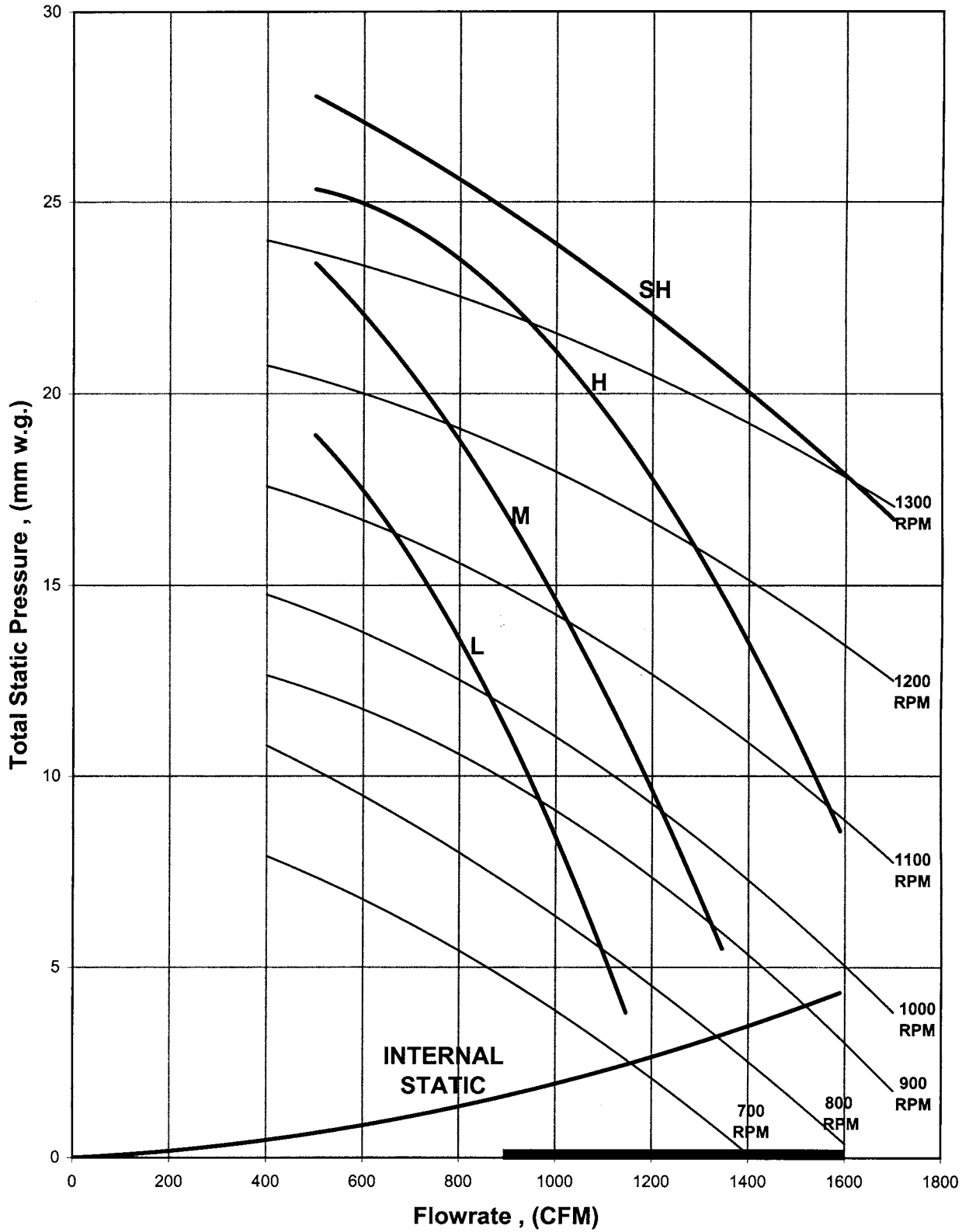

BLOWER PERFORMANCE CURVE MCC 050CW

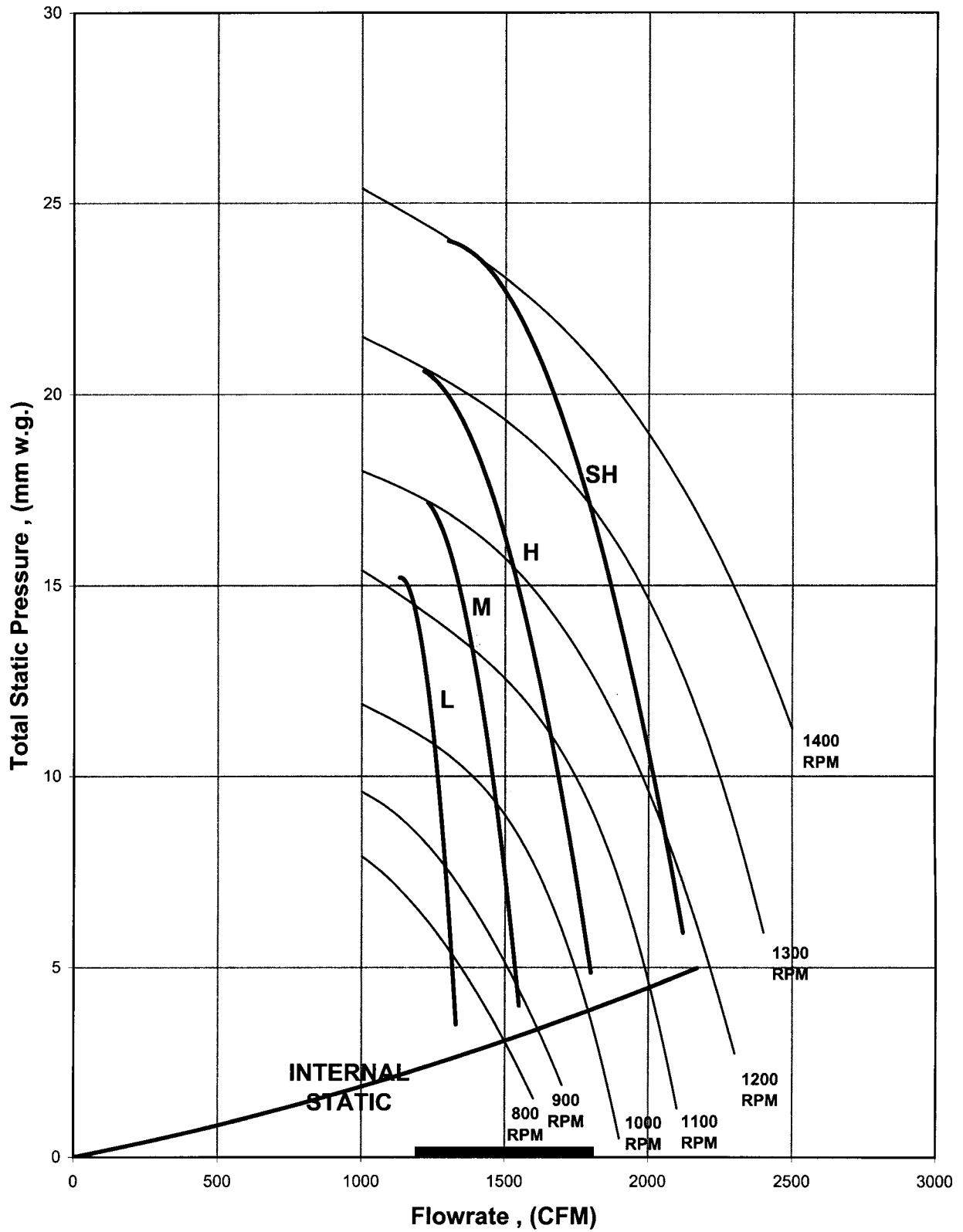

BLOWER PERFORMANCE CURVE MCC 060CW

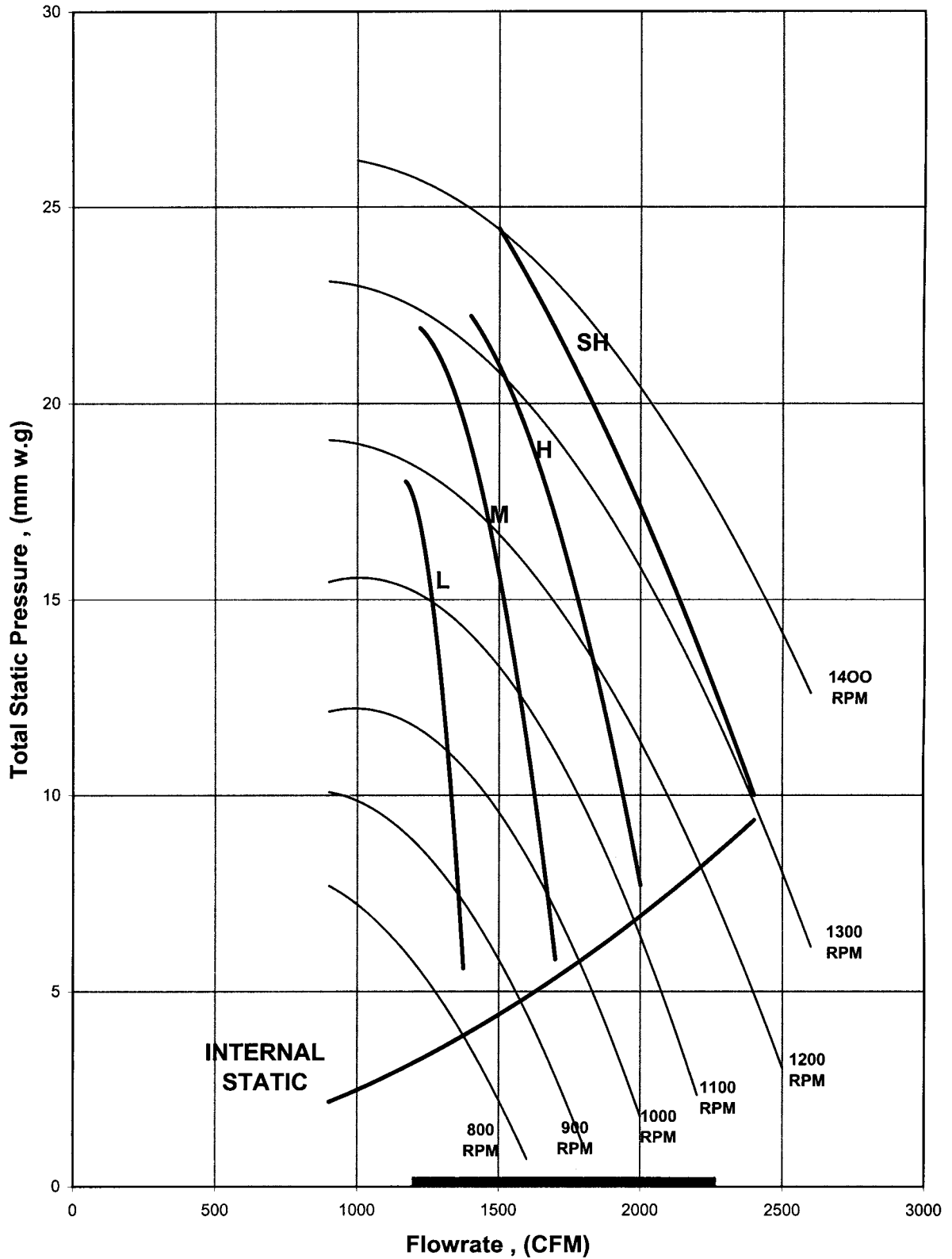

BLOWER PERFORMANCE CURVE MDB075BW

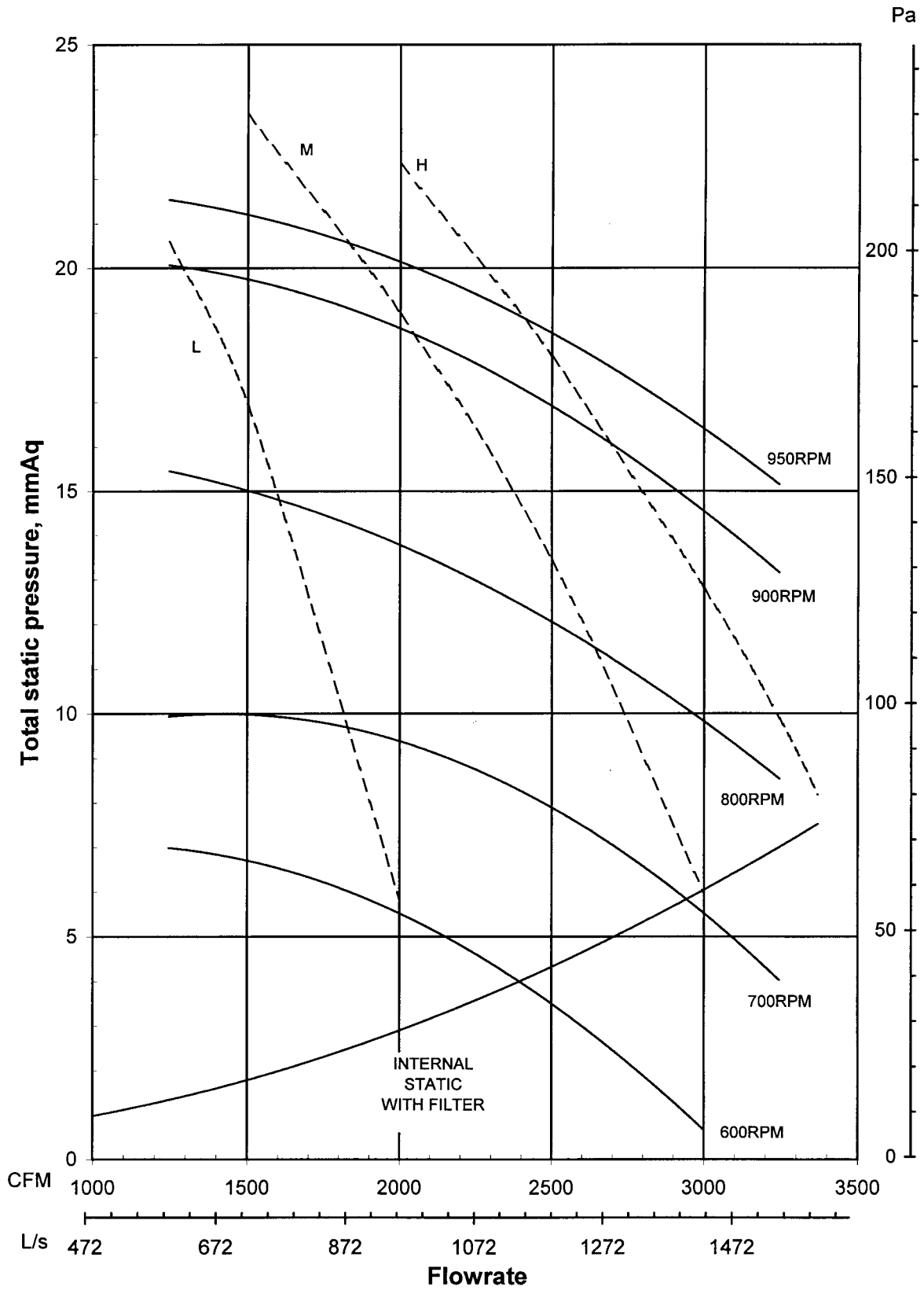

BLOWER PERFORMANCE CURVE MDB100BW

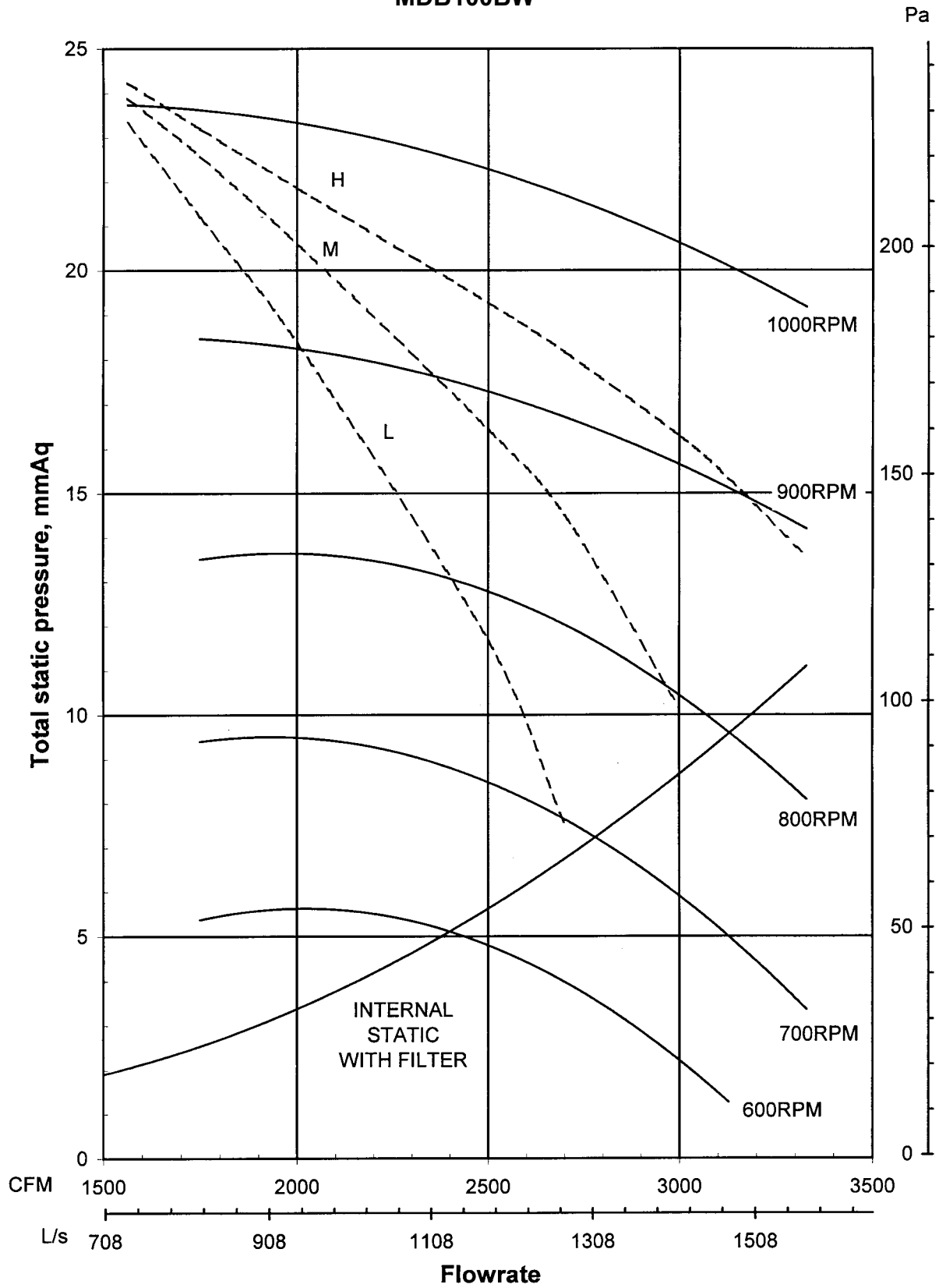

BLOWER PERFORMANCE CURVE MDB125BW

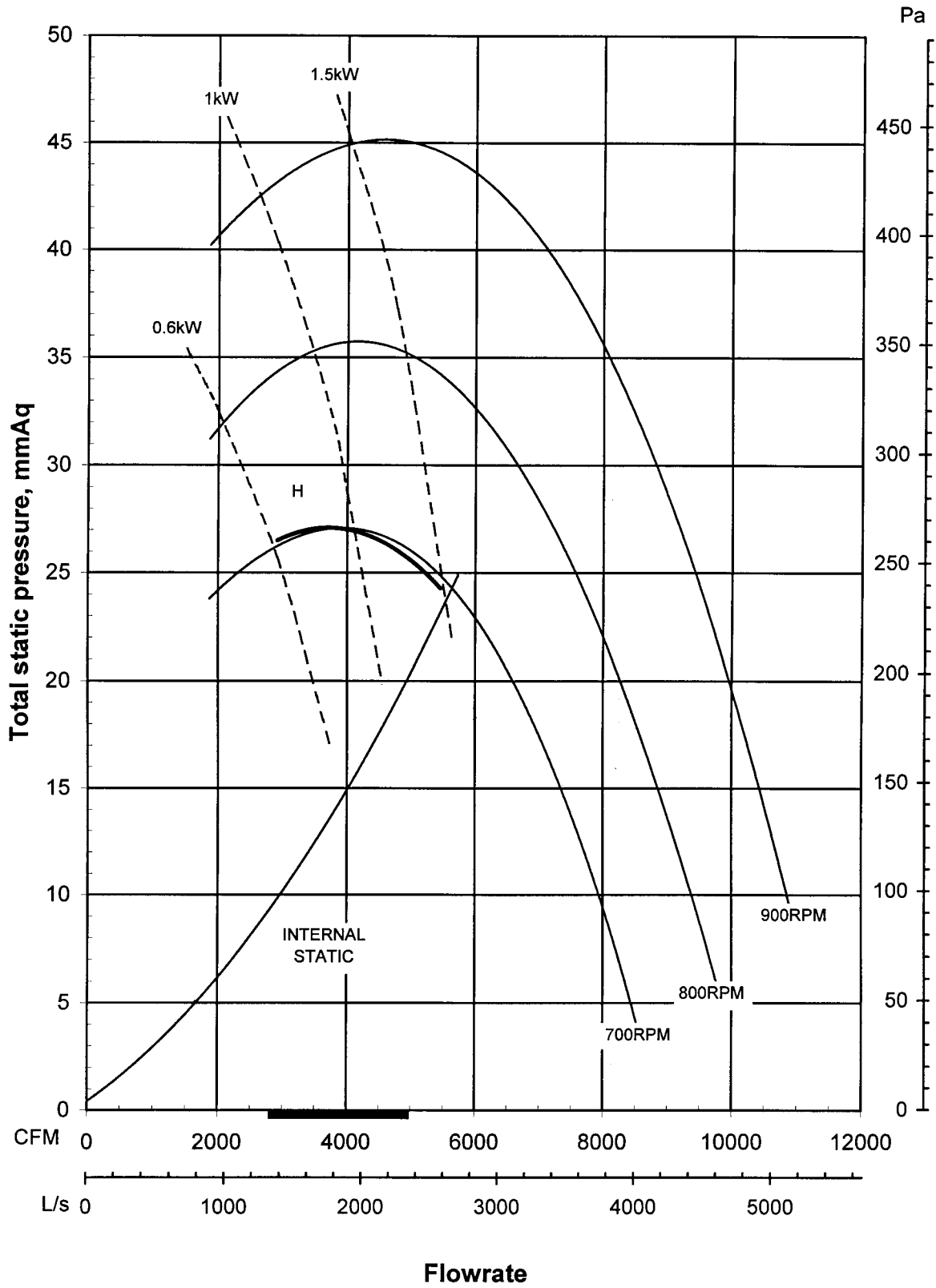

BLOWER PERFORMANCE CURVE MDB150BW

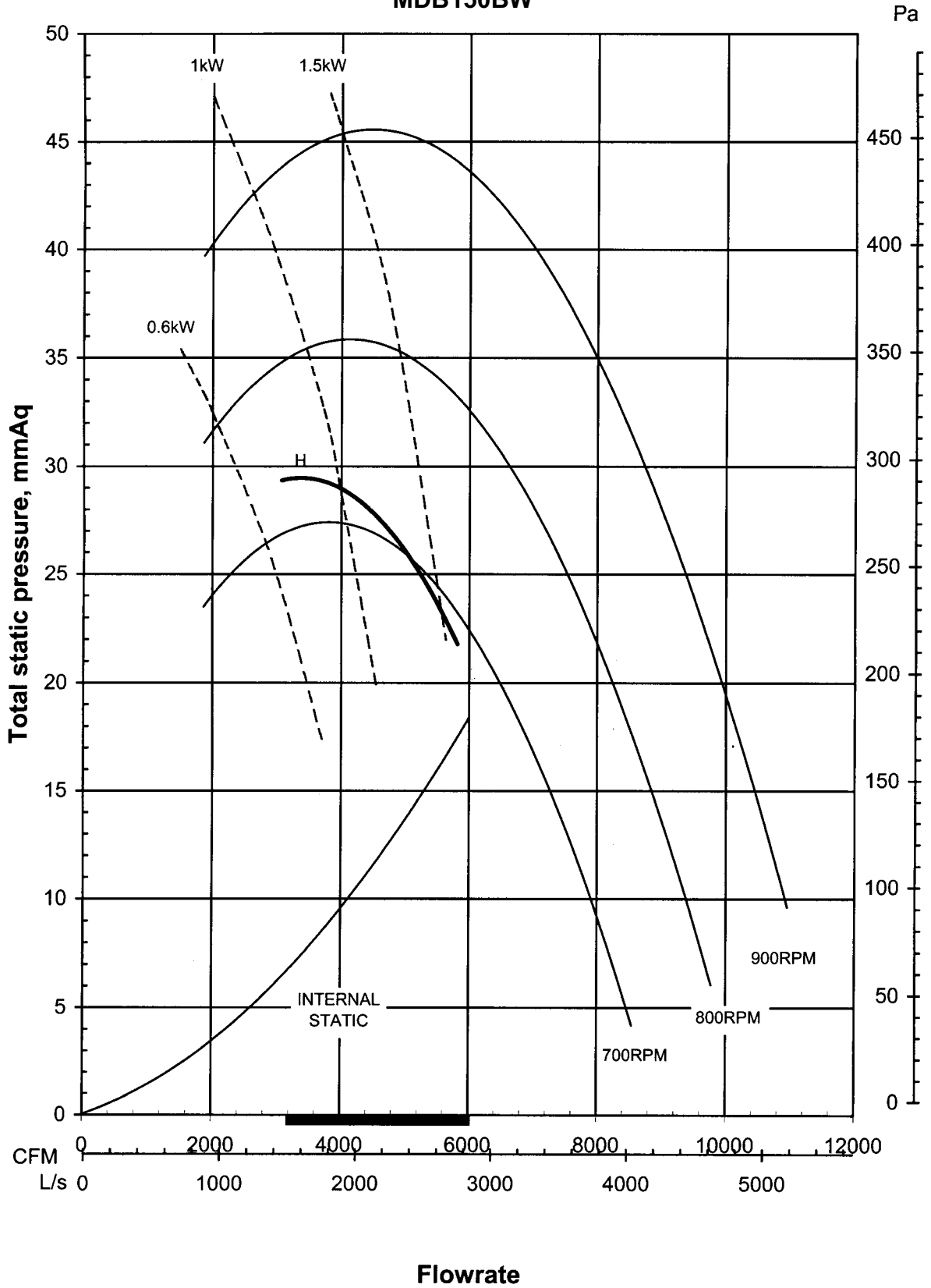

Outlines And Dimensions

Indoor Unit

Model: MWM 005FW / 007FW / 010FW / 015FW

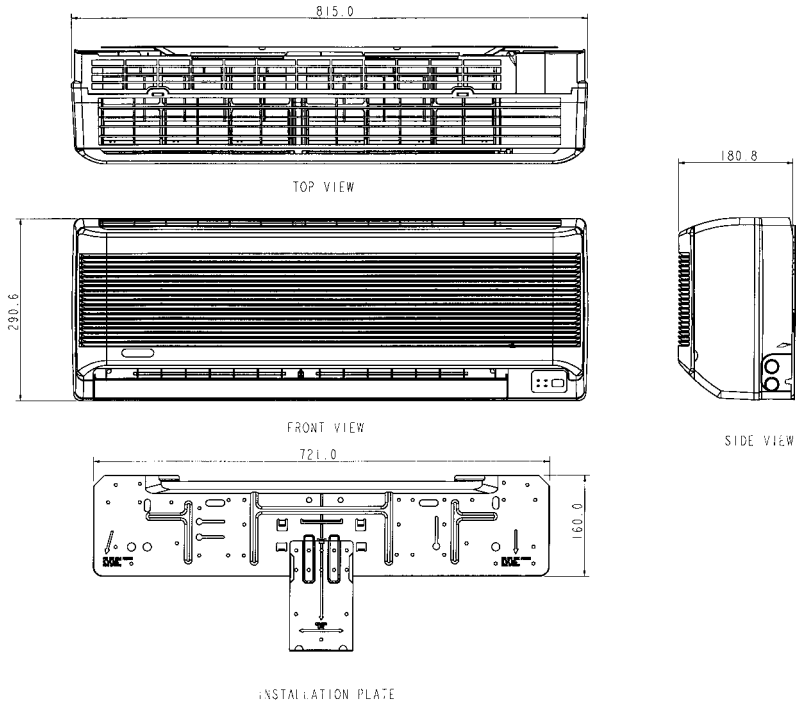

Note : Dimension in mm

Indoor Unit

Model : MWM 020FW / 025FW

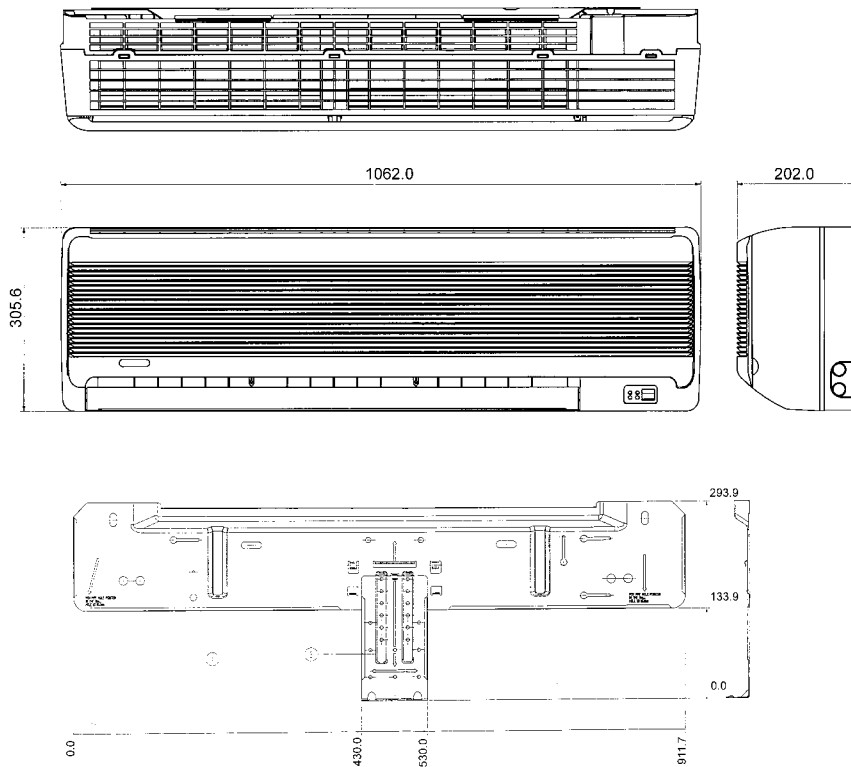

Note : Dimension in mm

**Model : MCK 020AW / 025AW / 030AW / 040AW / 050AW
MCK 015BW / 020BW / 025BW / 030BW**

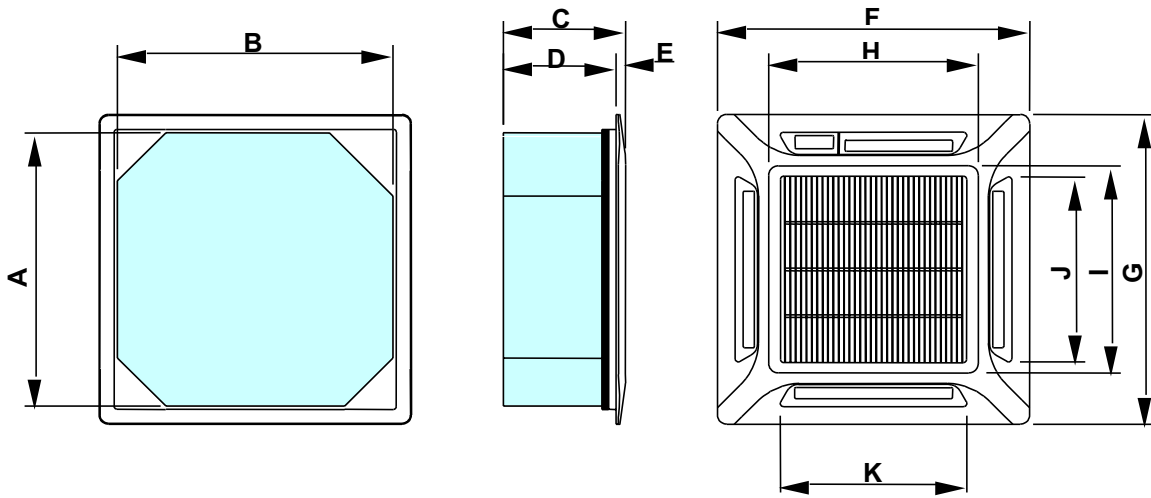

MODEL	A	B	C	D	E	F	G	H	I	J	K
MCK-AW	820	820	363	335	28	930	930	624	622	555	555
MCK-BW	650	650	345	323	22	727	727	489	489	444	444

Model : MCM 020DW / 025DW

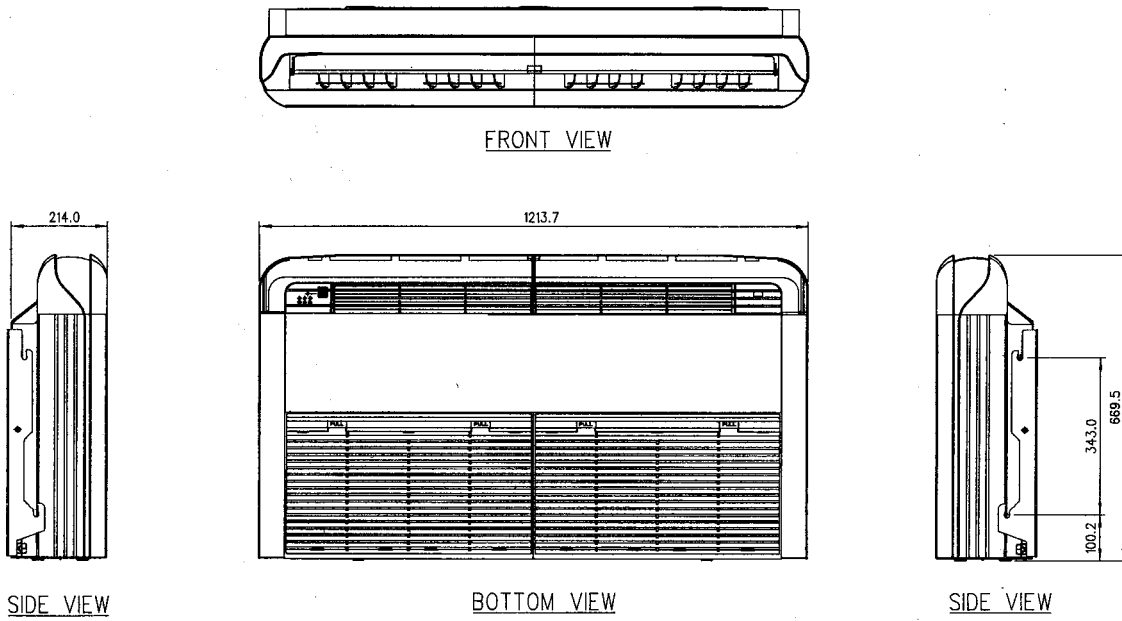

Model : MCM 030DW / 040DW / 050DW

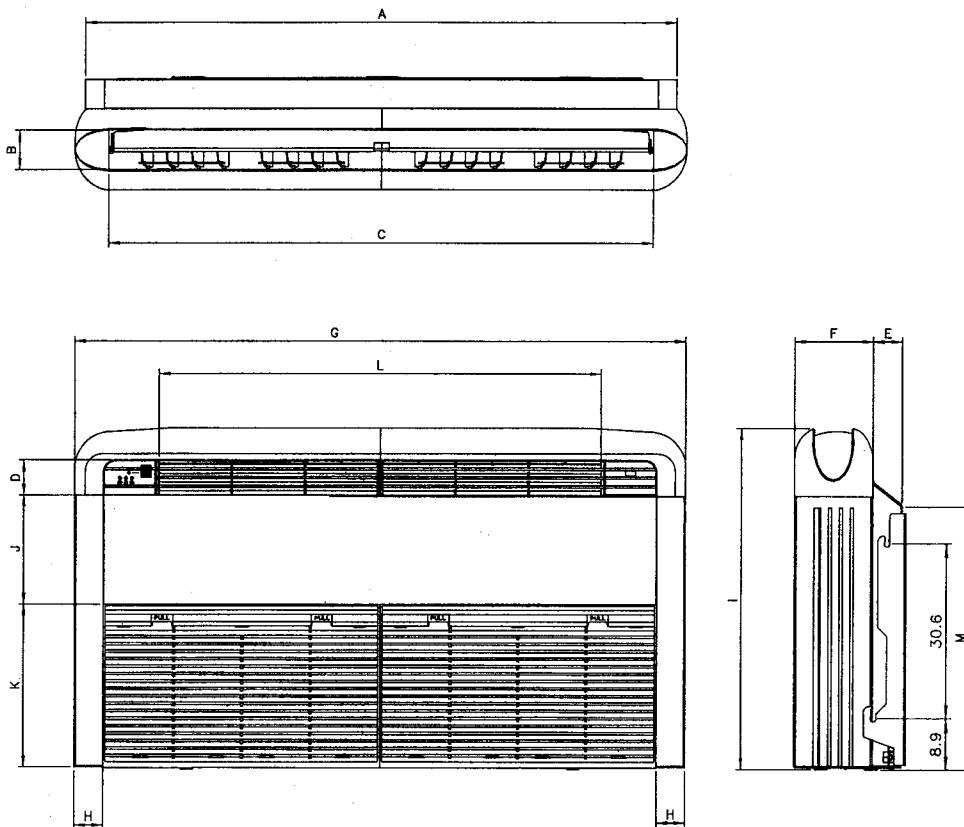

Model	A	B	C	D	E	F	G	H	I	J	K	L	M
MCM030DW	1174	75	1082	68	58	156	1214	57	670	216	319	879	517
MCM040DW	1674	75	1582	68	93	156	1714	57	670	216	319	1379	517
MCM050DW	1674	75	1582	68	93	156	1714	57	670	216	319	1379	517

Model : MCC 010CW

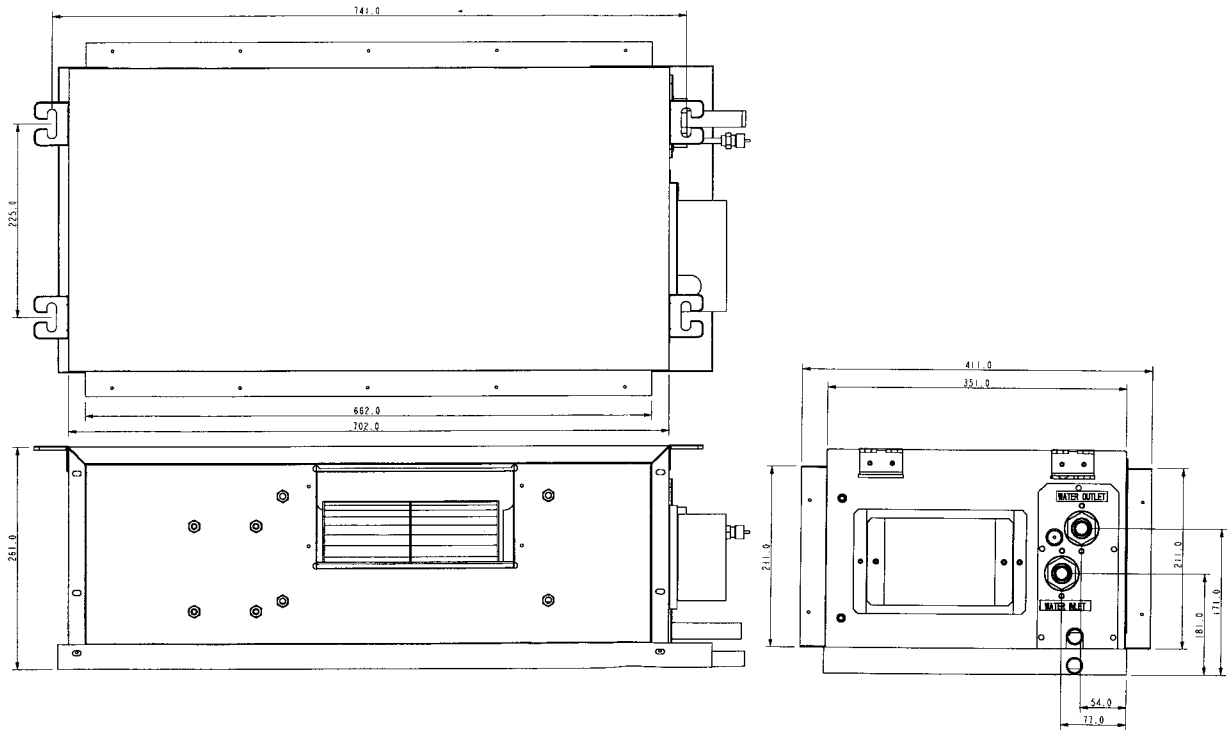

Model : MCC 015CW / 020CW / 025CW

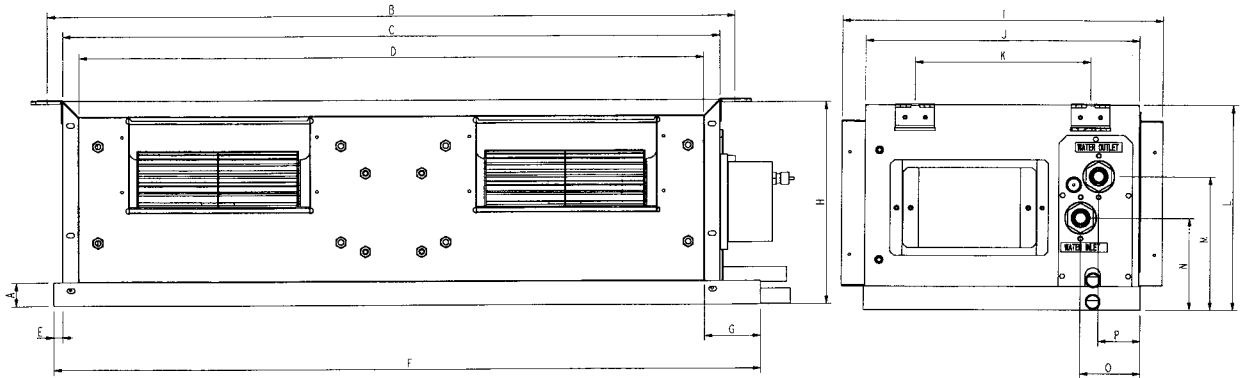

Model	A	B	C	D	E	F	G	H	I	J	K	L	M	N	O	P
MCC015CW	31	881	841	802	10	905	72	261	411	349	225	261	171	118	77	54
MCC020CW	31	1041	1002	962	10	1005	72	261	411	349	225	261	174	128	55	55
MCC025CW	31	1176	1137	1097	10	1200	72	261	411	349	225	261	171	118	77	54

Model : MCC 028CW

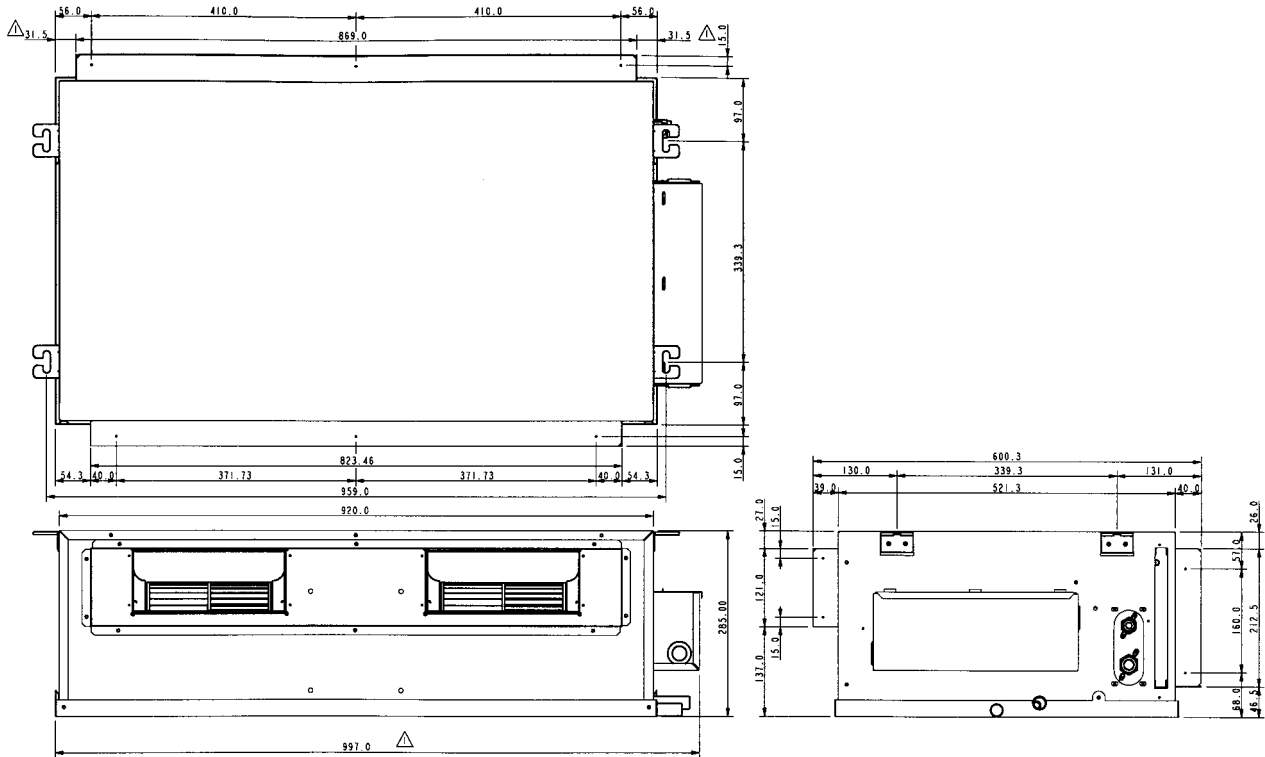

NOTE : FOR EXPORT ONLY.

Model : MCC 038CW

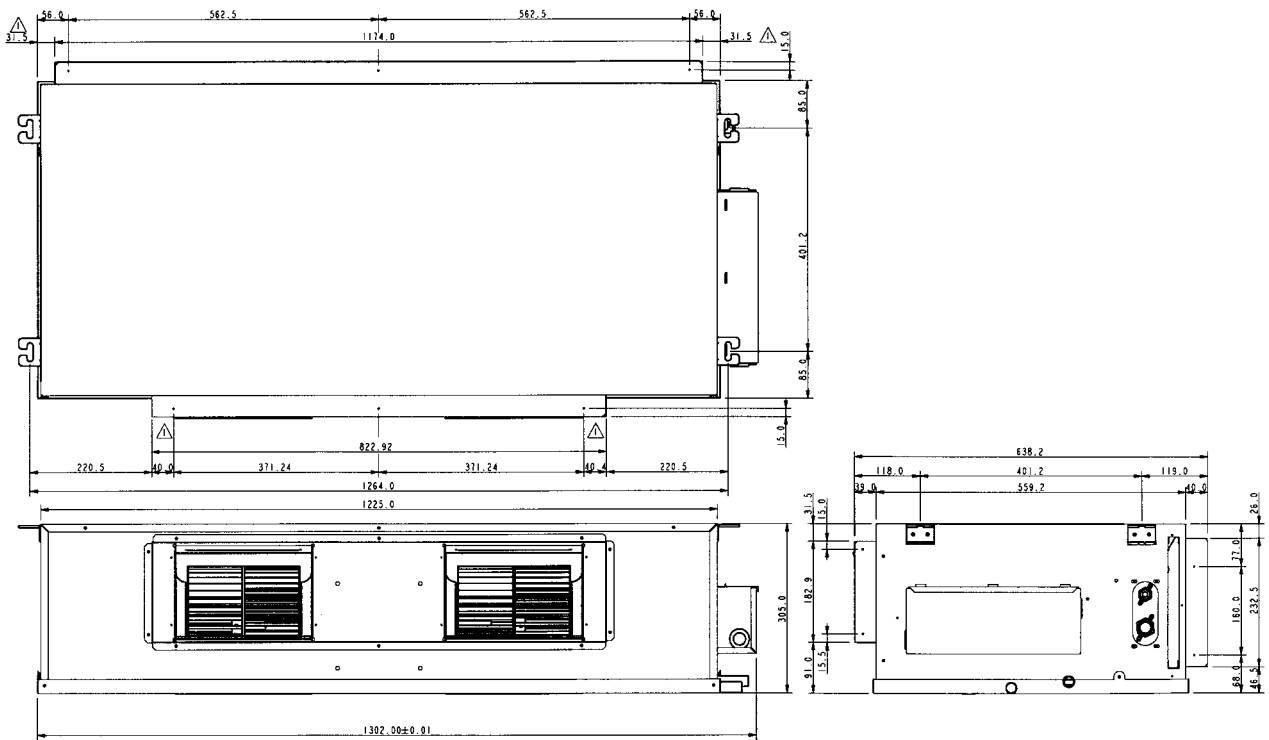

NOTE : FOR EXPORT ONLY.

Model : MCC 030CW

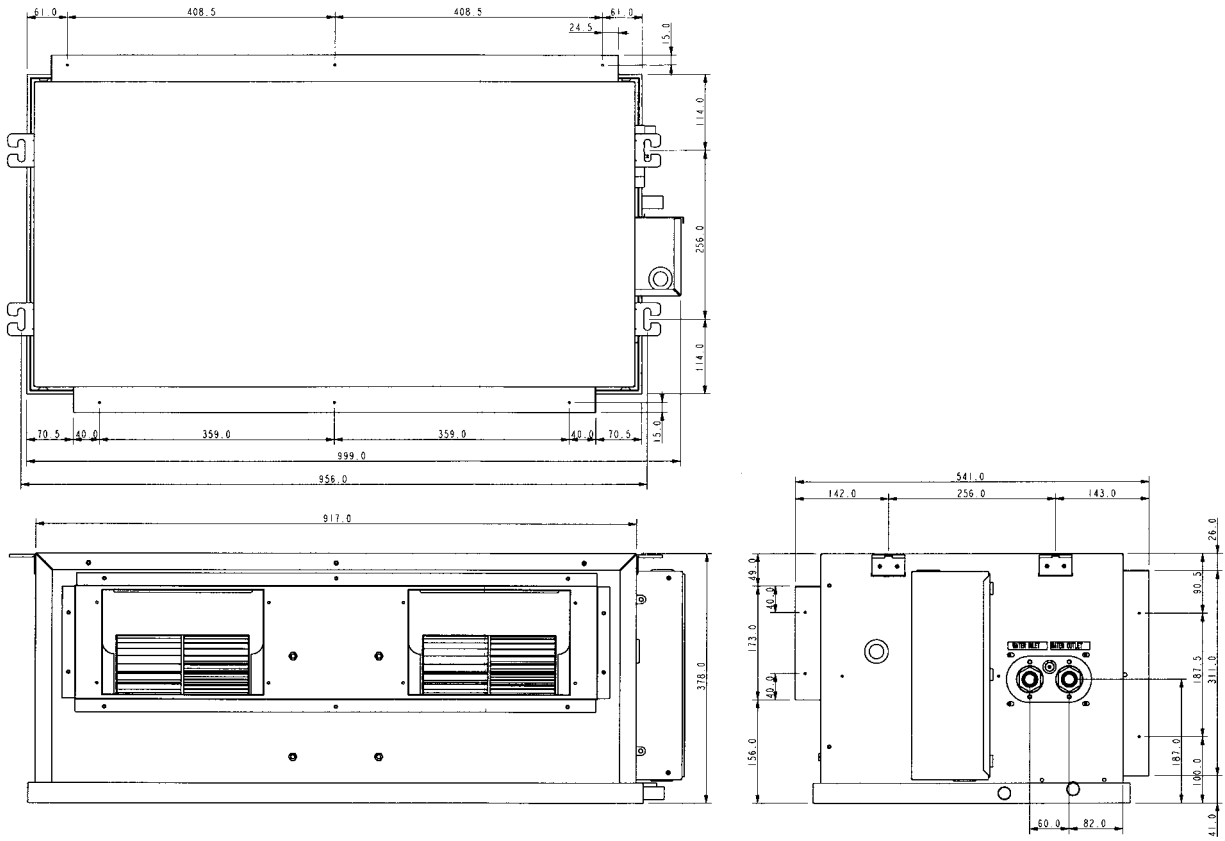

Model : MCC 040CW

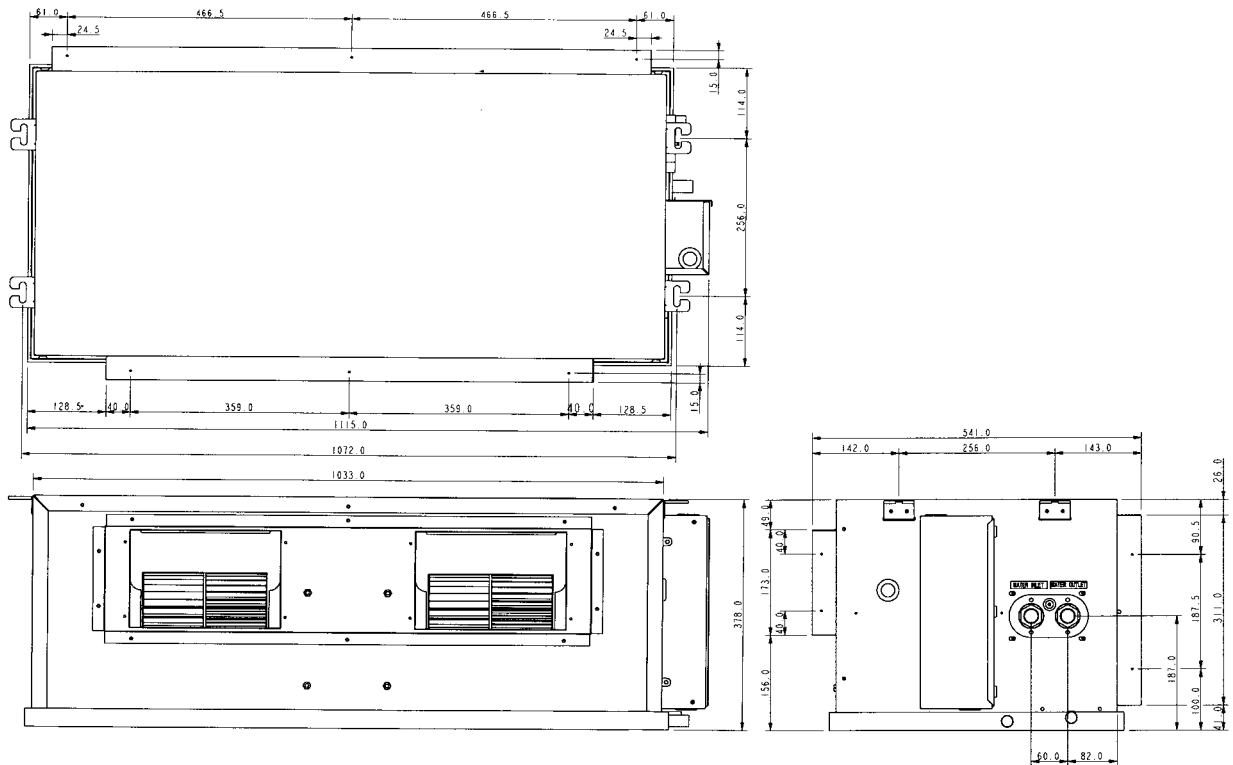

Model : MCC 050CW

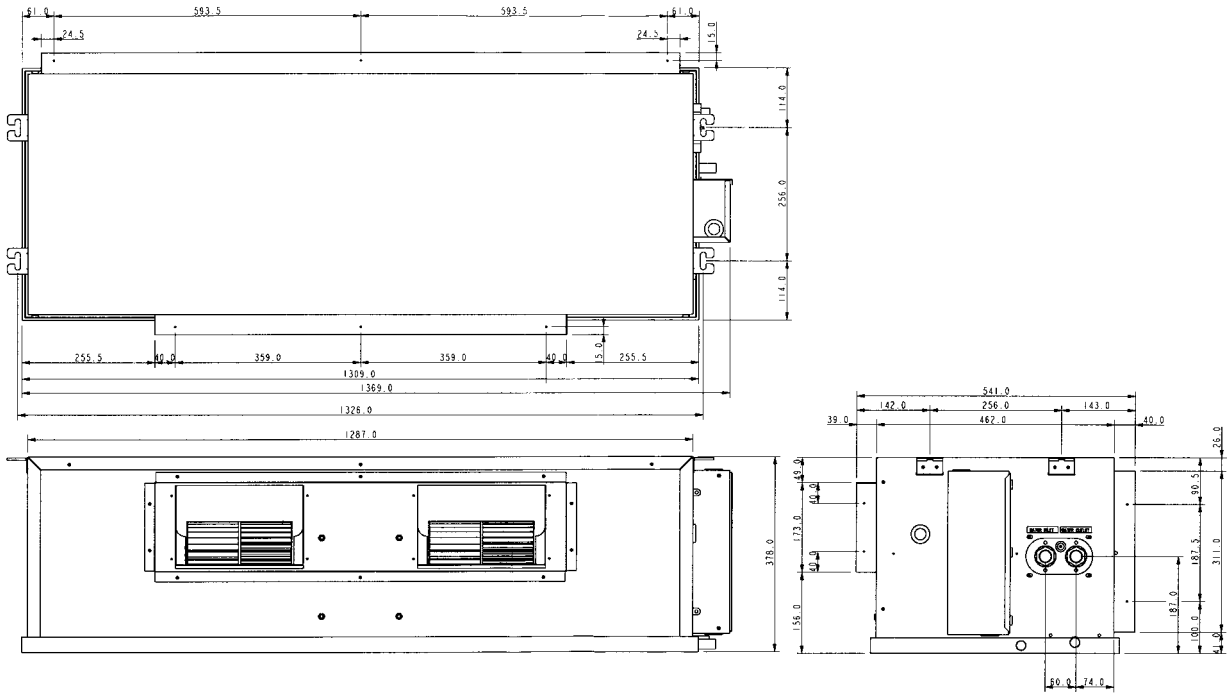

Model : MCC 060CW

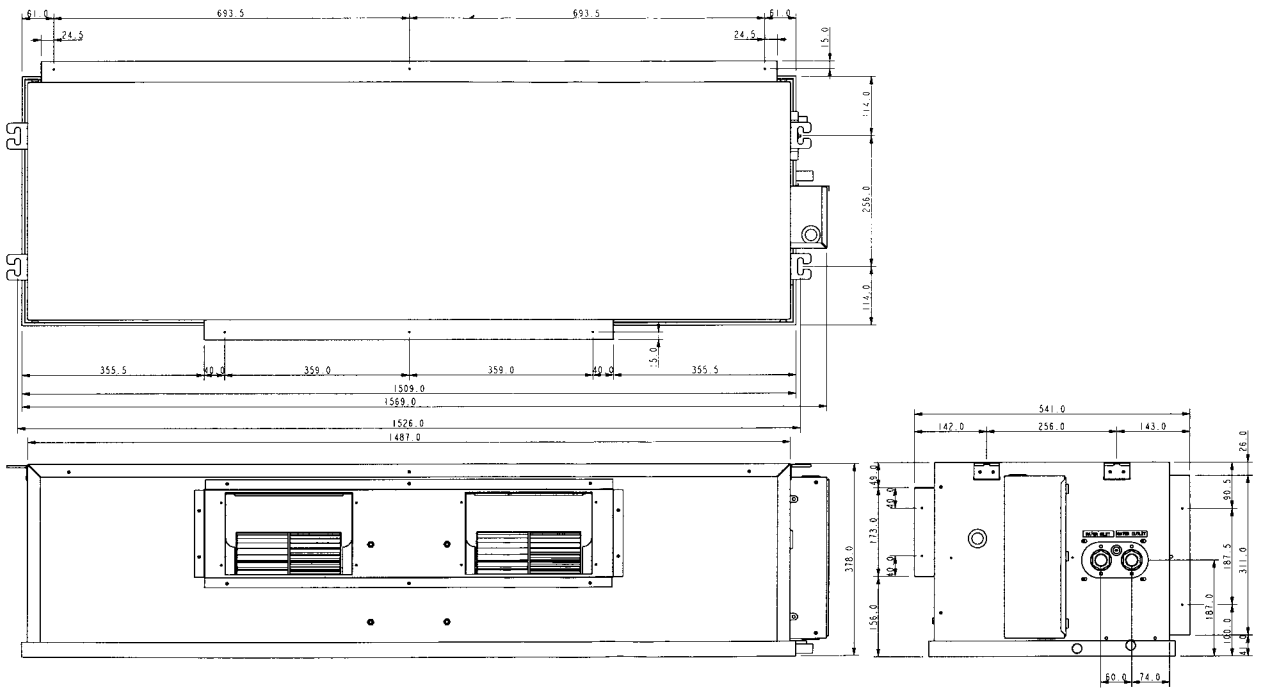

Model : MDB 075BW / 100BW (RIGHT PIPING)

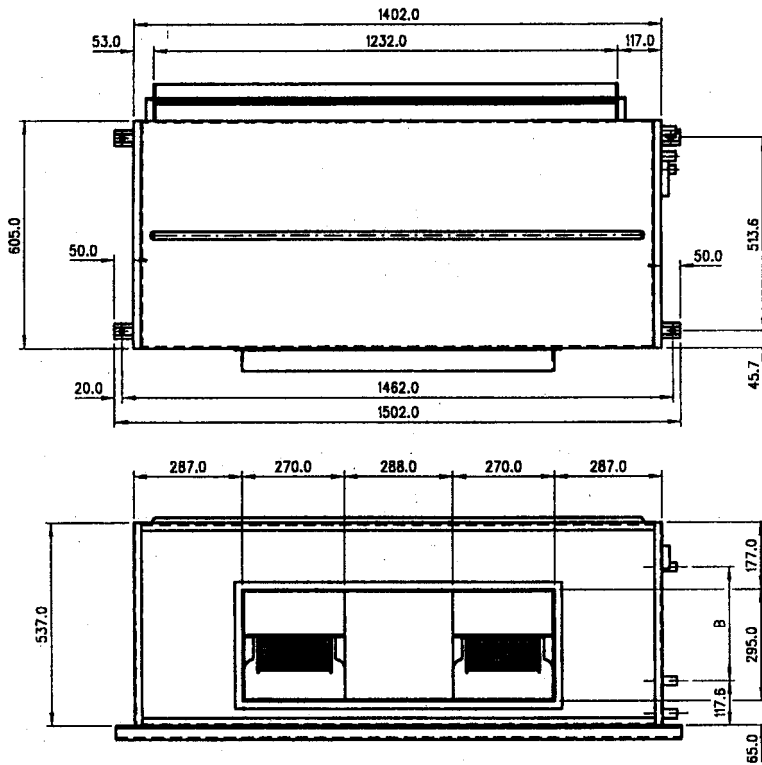

Model	A	B
MDB075BW	72	301.8
MDB100BW	94	289.1

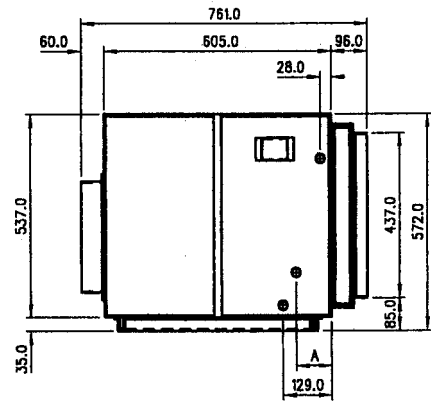

Model : MDB 075BW / 100BW (LEFT PIPING)

Model	A	B
MDB075BW	72	301.8
MDB100BW	94	289.1

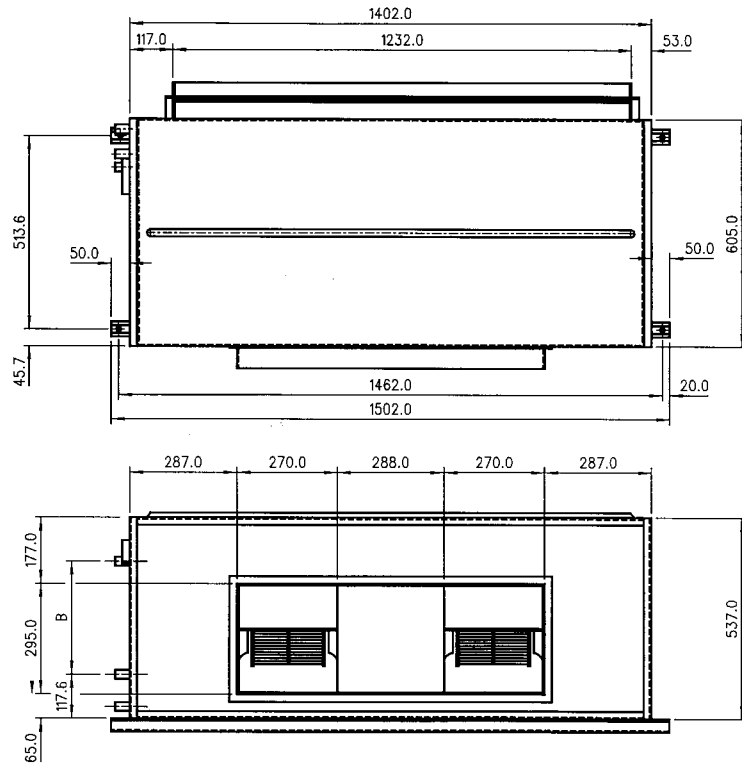
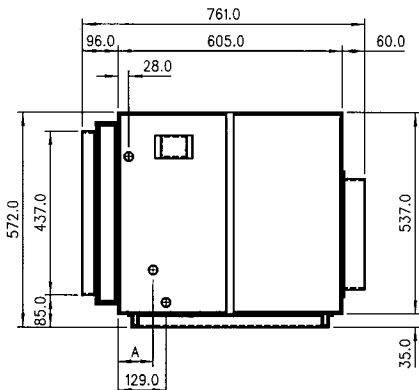

Model : MDB 125BW (Vertical Air Discharge With Right Piping)

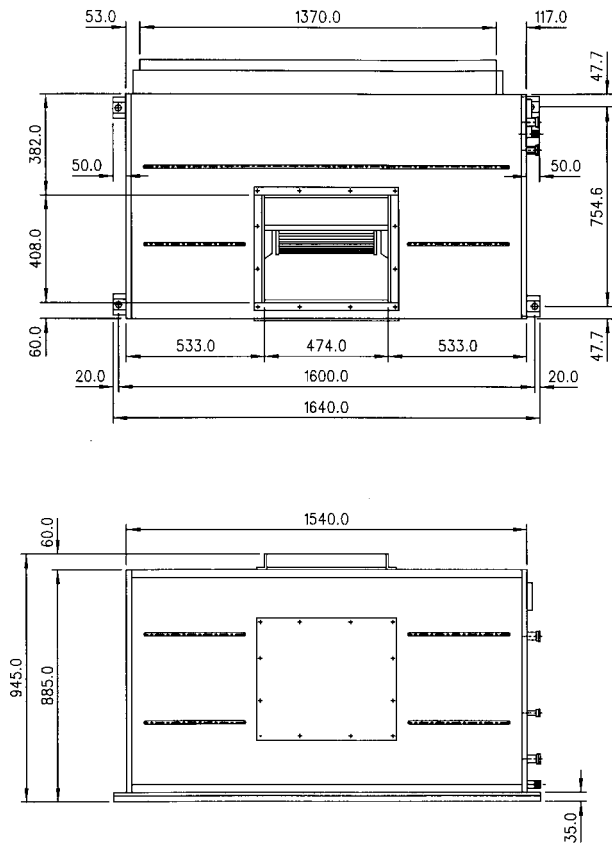

NOTE :
FOR VERTICAL AIR DISCHARGE

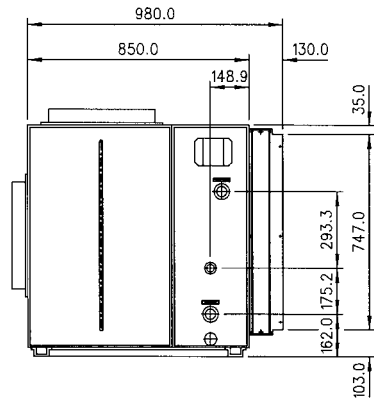

Model : MDB 125BW (Vertical Air Discharge With Left Piping)

NOTE:
FOR VERTICAL AIR DISCHARGE

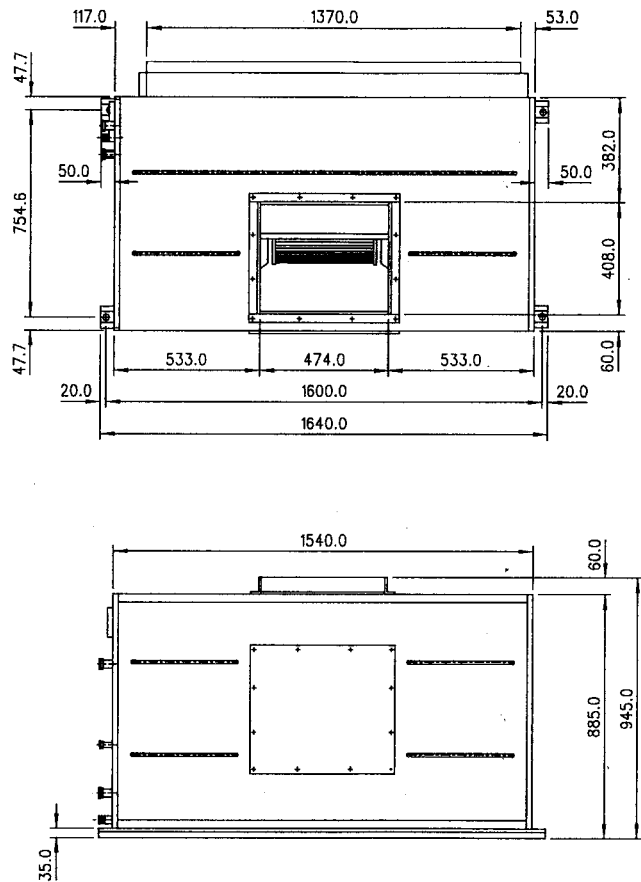

Model : MDB 125BW (Horizontal Air Discharge With Right Piping)

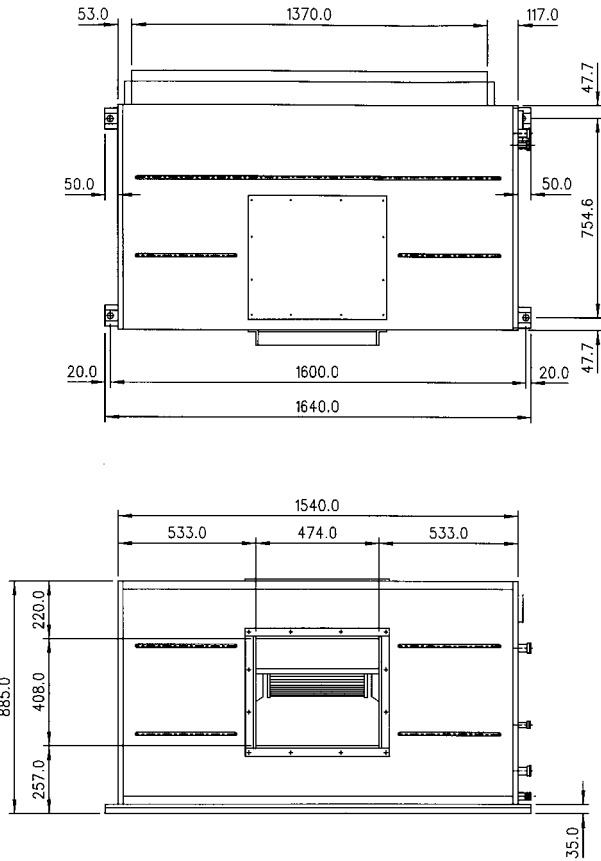

NOTE :
FOR HORIZONTAL AIR DISCHARGE

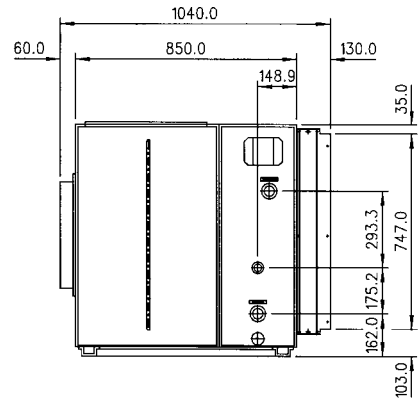

Model : MDB 125BW (Horizontal Air Discharge With Left Piping)

NOTE :
FOR HORIZONTAL AIR DISCHARGE

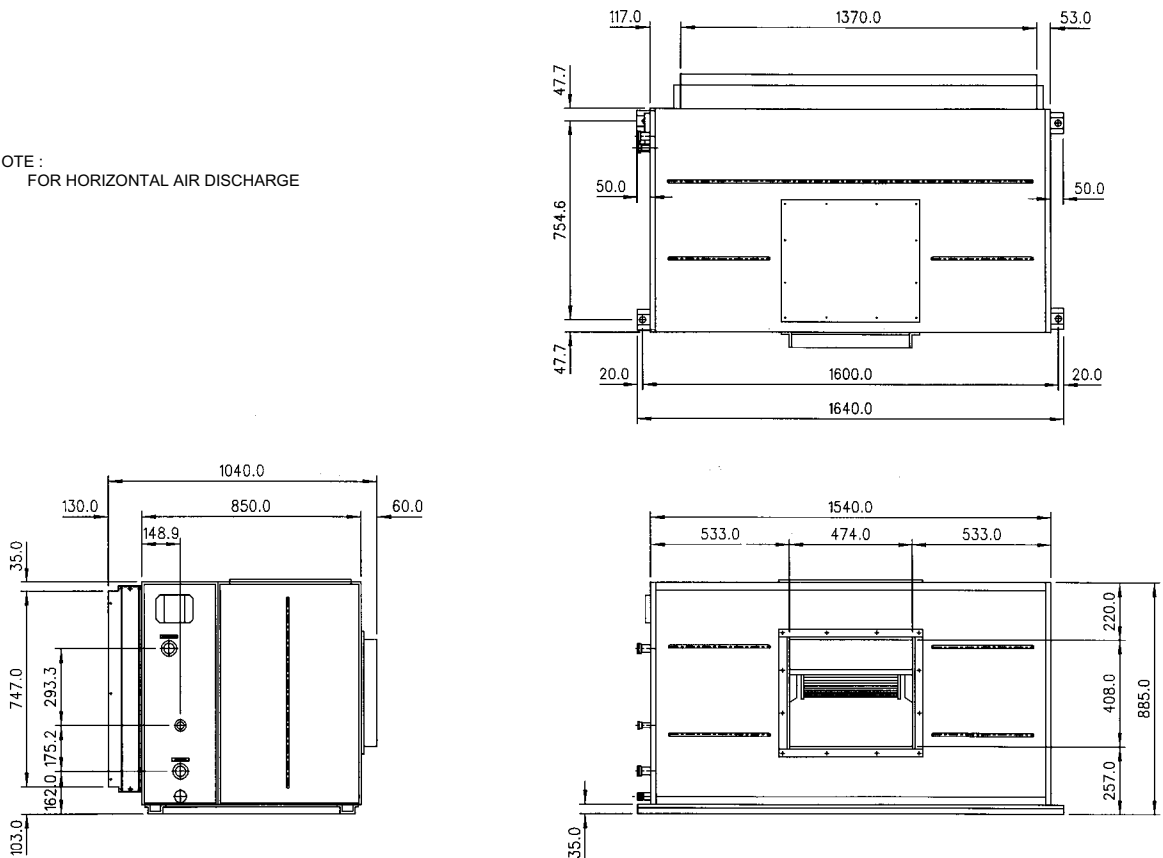

Model : MDB 150BW (Vertical Air Discharge With Left Piping)

NOTE:
FOR VERTICAL AIR DISCHARGE

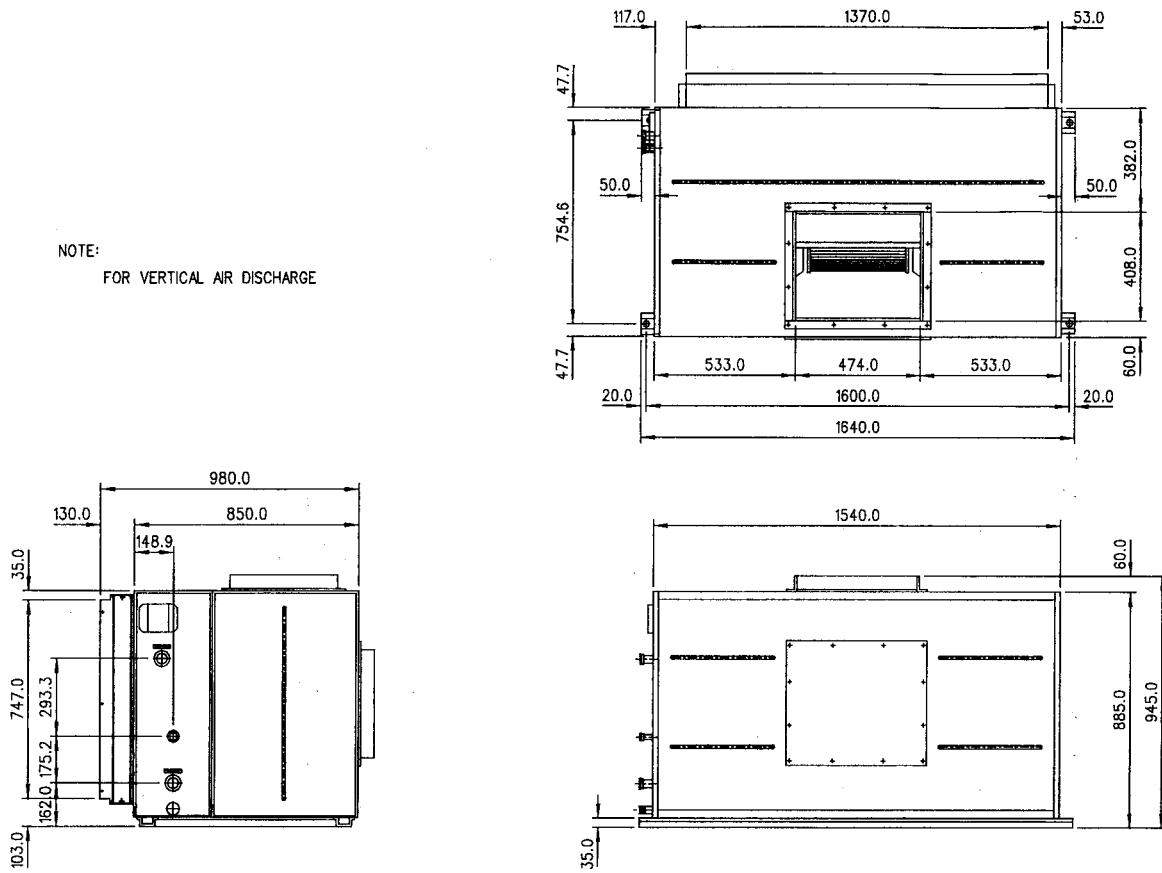

Model : MDB 150BW (Vertical Air Discharge With Right Piping)

NOTE :
FOR VERTICAL AIR DISCHARGE

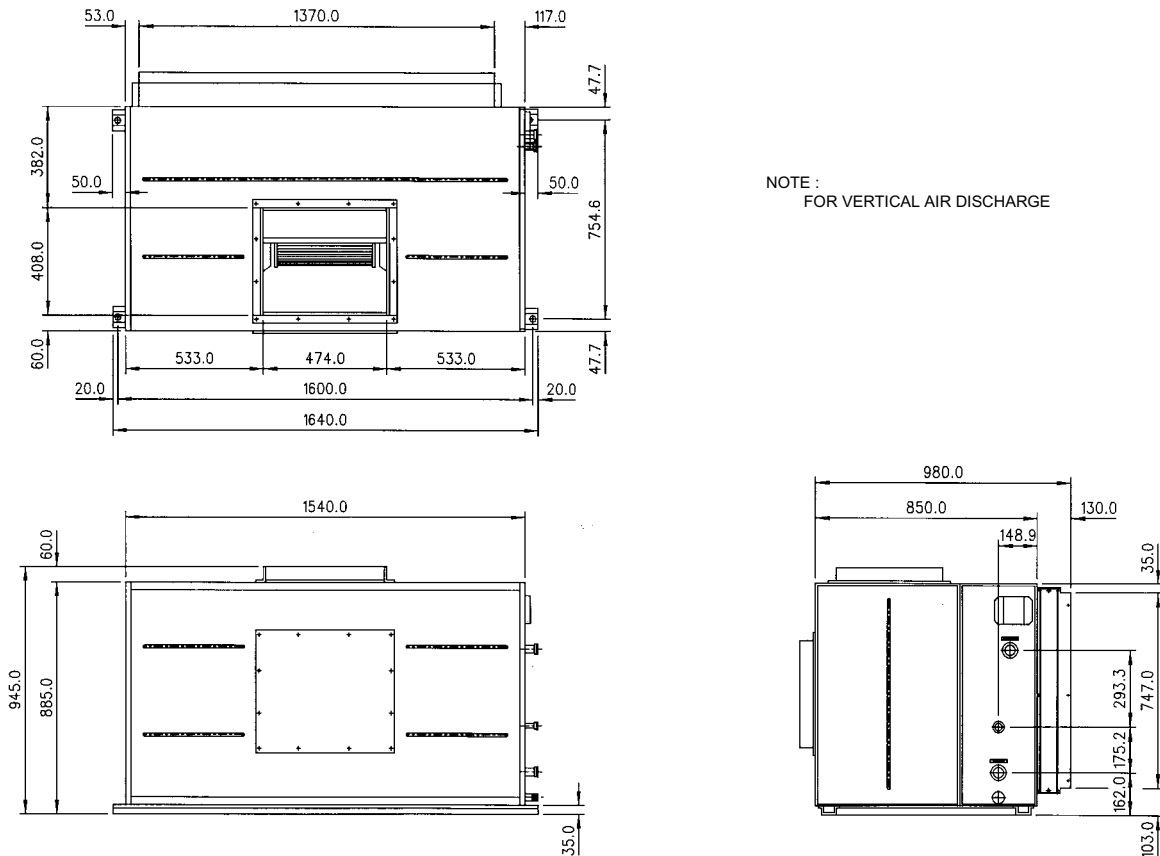

Model : MDB 150BW (Horizontal Air Discharge With Right Piping)

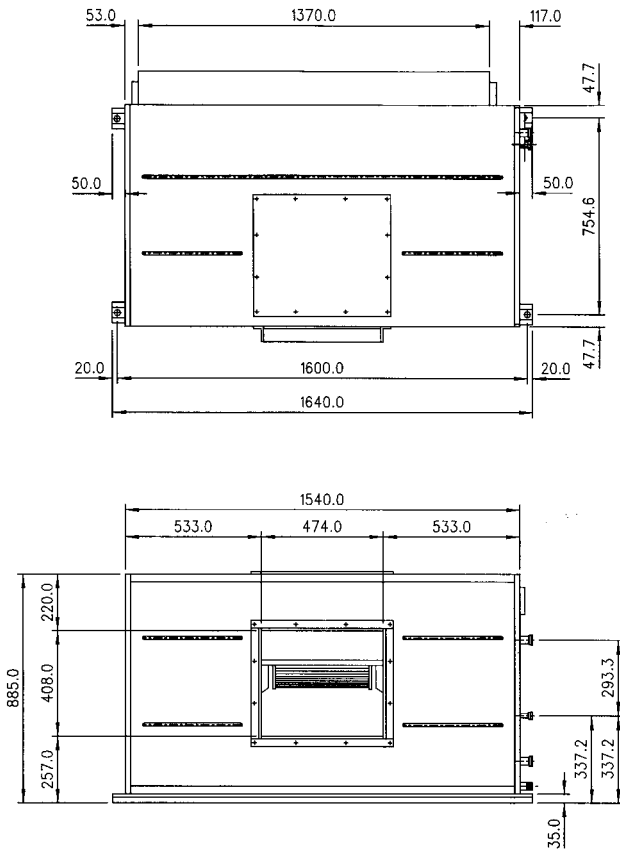

NOTE :
FOR HORIZONTAL AIR DISCHARGE

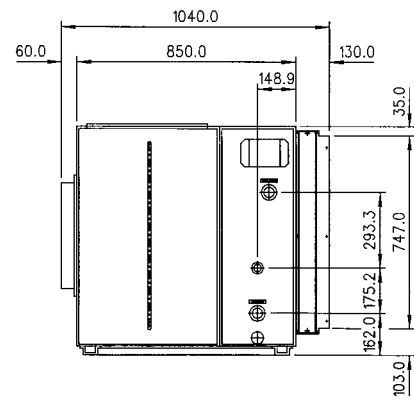

Model : MDB 150BW (Horizontal Air Discharge With Left Piping)

NOTE :
FOR HORIZONTAL AIR DISCHARGE

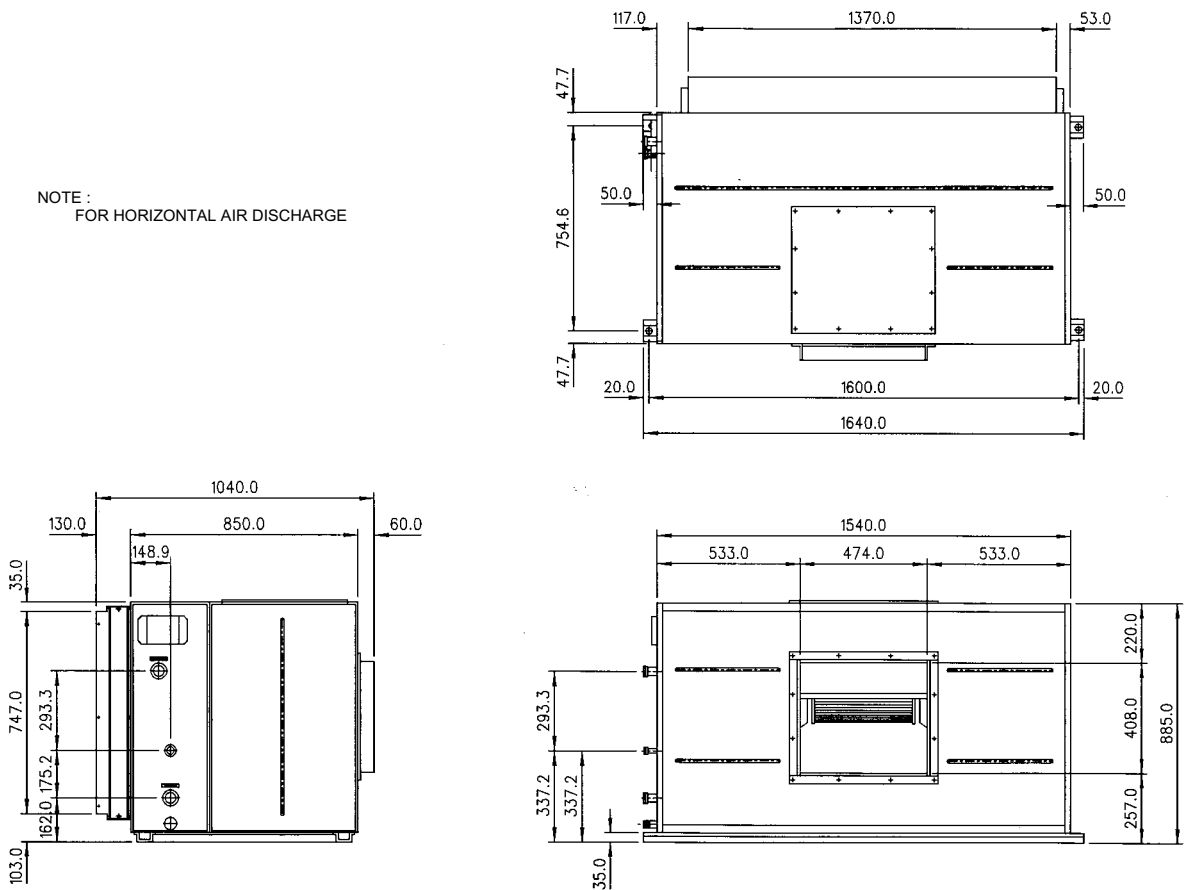

General Installation Guide

System Configuration

The standard controller board (W1V3) comes with a VALVE jumper and a HEAT jumper. The system can be configured as the jumper selection listed below:

	HEAT Jumper	VALVE Jumper
Heatpump Mode & Valve Application	v	v
Heatpump Mode & Valveless Application	v	X
Cooling Mode & Valve Application	X	v
Cooling Mode & Valveless Application	X	X

v Jumper Remained X Jumper Removed

CAUTION !

Disconnect the power supply to the unit before attempting to connect the wiring.

VALVE & HEAT Jumper Location

MODEL: MWM 005 - 025FW

1. VALVE jumper is plugged into JVLV connector on the emergency switch board.
2. HEAT jumper is plugged into JMODE connector on the emergency switch board.

MODEL: MCK 020 - 050AW, MCK 015 - 030BW, MCM 020 - 050DW and MCC 010 - 060CW

1. VALVE jumper is plugged into JVLV connector on the main board.
2. HEAT jumper is plugged into OD connector on the main board.

MODEL: MWM 005FW / 007FW / 010FW / 015FW (G6 CONTROLLER)

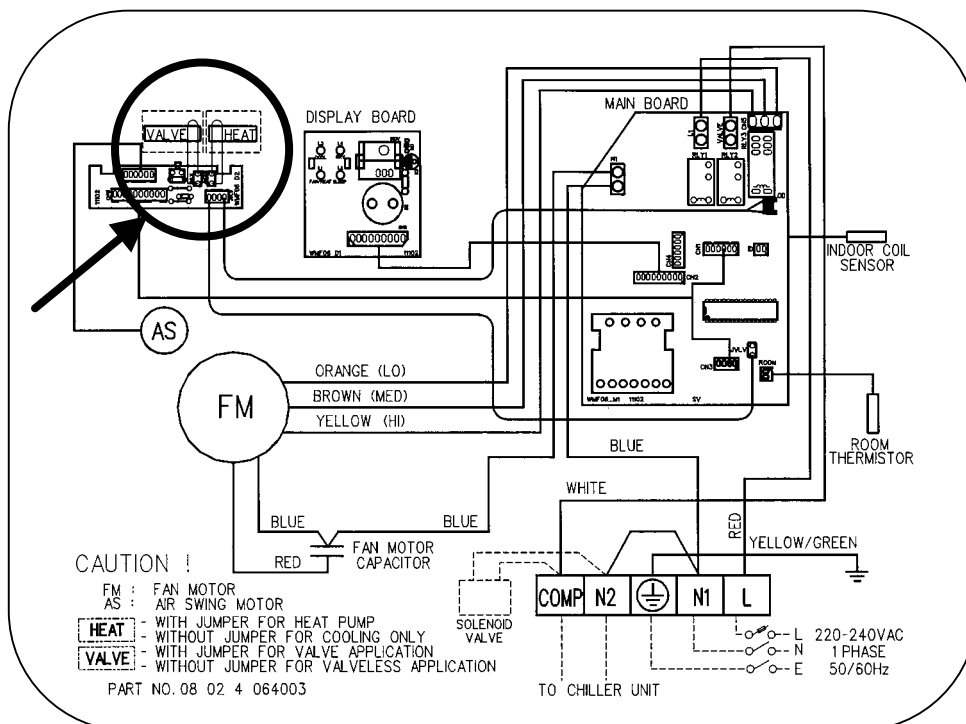

Model : MWM 005FW / 007FW / 010FW / 015FW (Netware2 / SLM3 Controller)

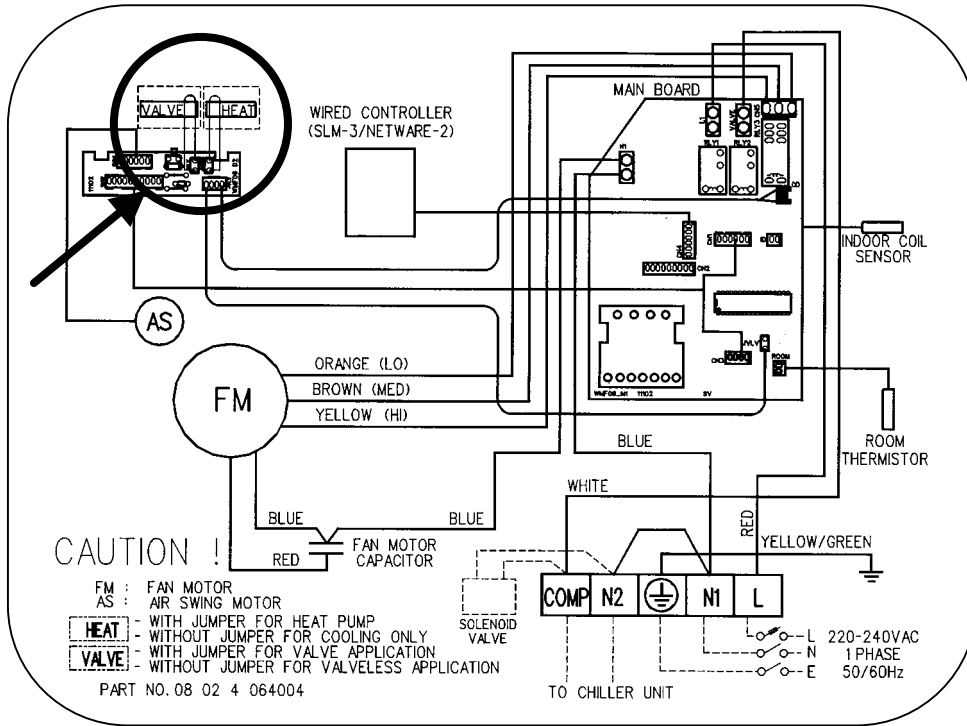

Model : MWM 020FW / 025FW (G6 Controller)

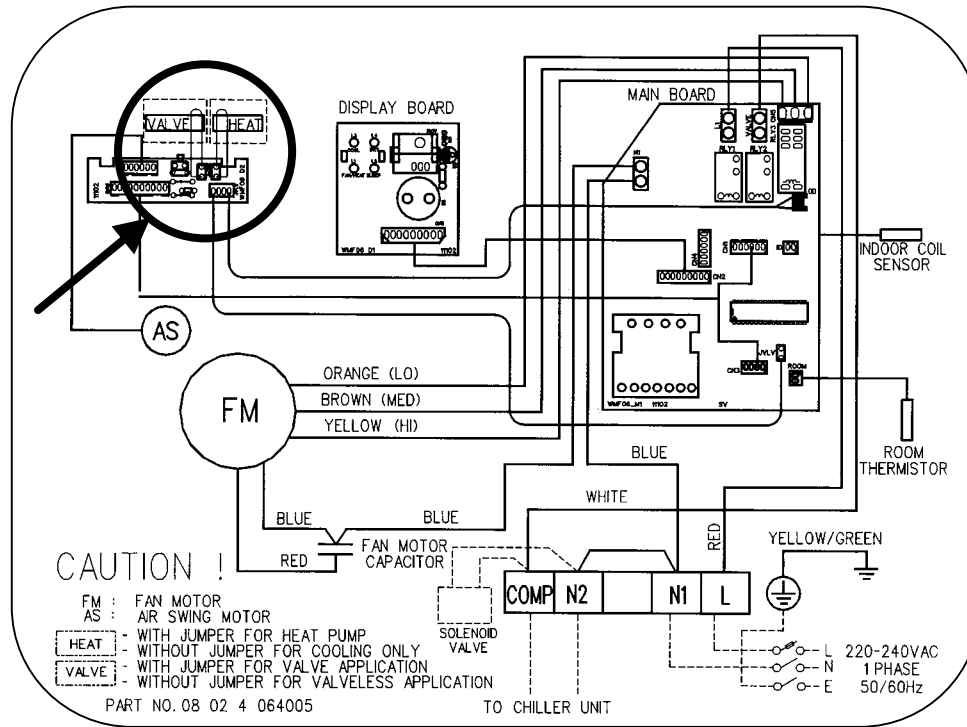

Model : MWM 020FW / 025FW (Netware2 / SLM3 Controller)

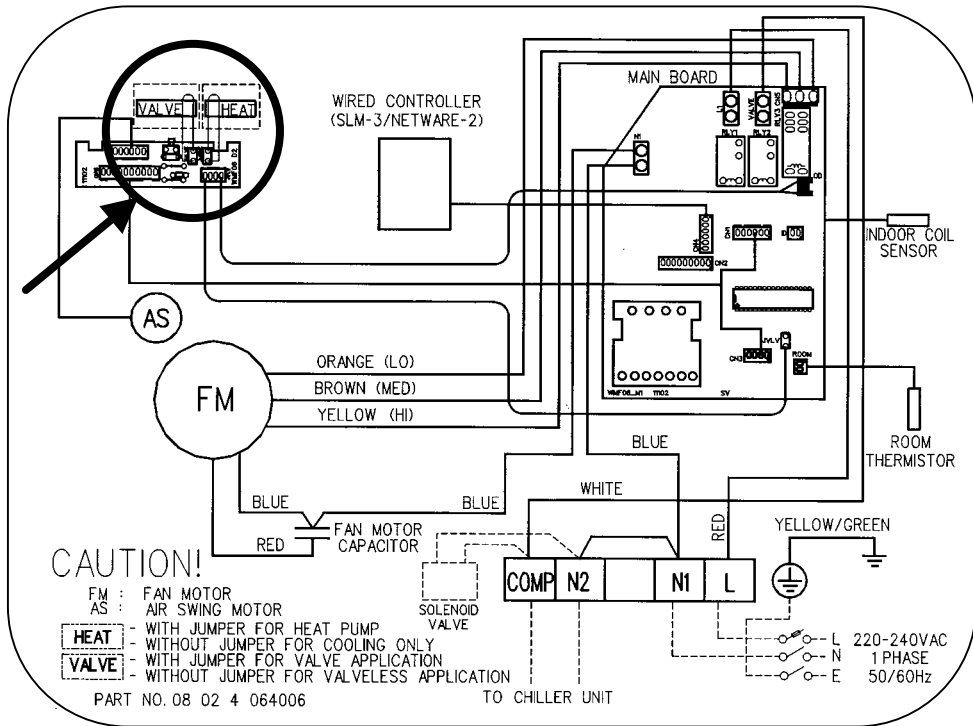

Model : MCK 020AW / 025AW / 030AW / 040AW / 050AW (G6, Netware2 OR SLM3 Controller)

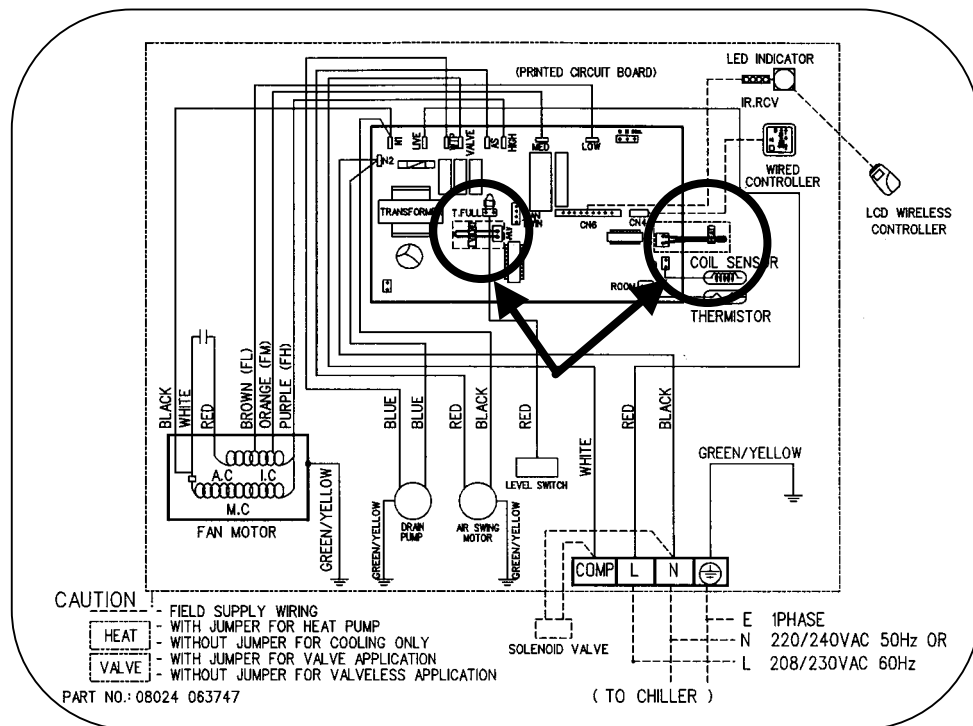

Model : MCK 015BW / 020BW / 025BW / 030BW (G6, Netware2 OR SLM3 Controller)

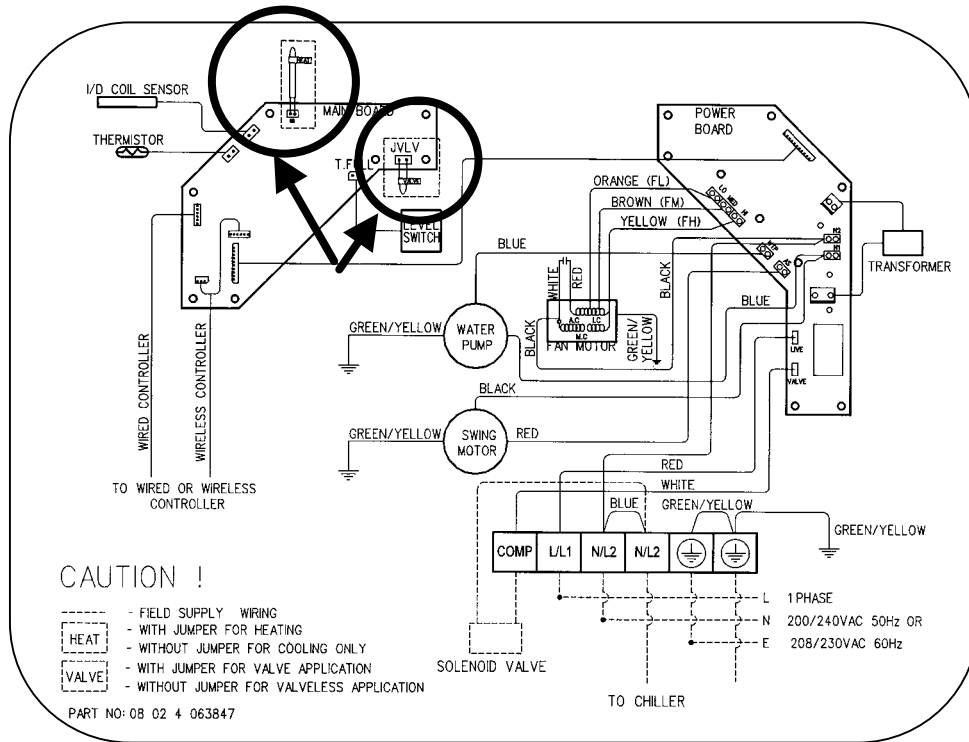

Model : MCM 020DW / 025DW / 030DW / 040DW / 050DW (G6, Netware2 OR SLM3 Controller)

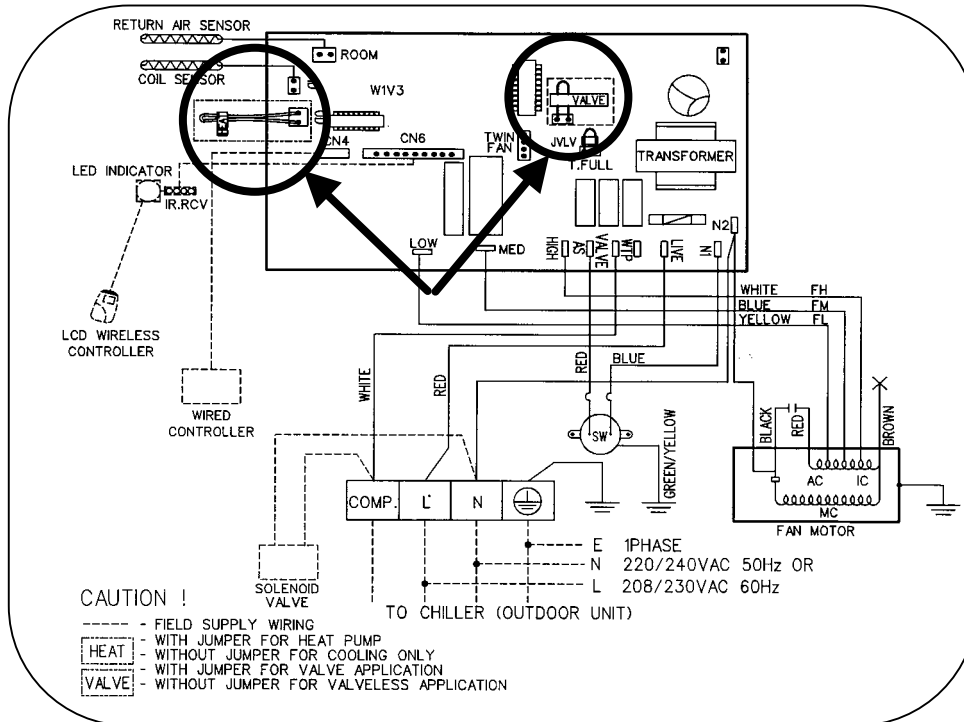

Model : MCC 010CW / 015CW / 020CW / 025CW (Netware2 / SLM3 Controller)

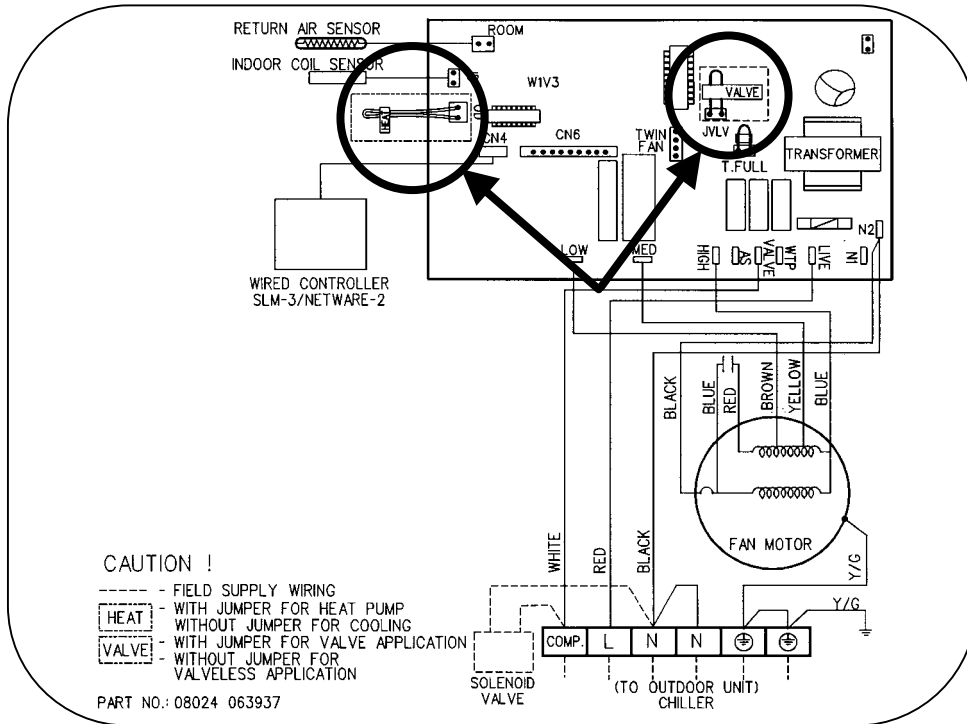

Model : MCC 028CW / 030CW / 038CW / 040CW / 050CW / 060CW (Netware2 / SLM3 Controller)

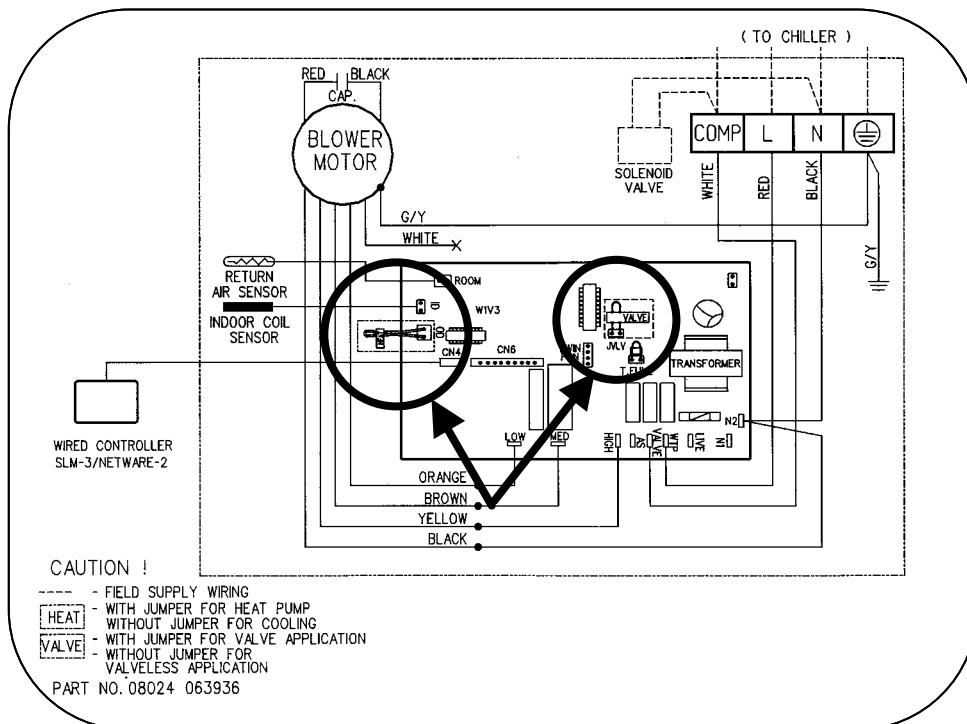

Preliminary Site Survey

Electrical supply and installation is to conform to LOCAL AUTHORITY's (e.g. National Electricity Board) CODES and REGULATIONS.

Voltage supply fluctuation must not exceed $\pm 10\%$ of rated voltage. Electricity supply lines must be independent of welding transformers which can cause supply fluctuation.

Ensure that the location is convenient for wiring and piping.

Mounting

For ceiling mounted models, locate a position where piping and ducting work can be kept to a minimum. Ensure that overhead supports are strong enough to hold the unit's weight. Position hanger rods and check for alignment with the unit. Check that hangers are secure and that the base of fan coil unit is level in two horizontal positions.

Piping

Drain and water piping must be accurately connected.

Please refer to "Specification Sheet" for piping sizes.

Piping Support

All water mains must be adequately supported to carry the necessary weight involved, provisions must be made by the installing contractor to allow for adequate free movement of all vertical and horizontal risers and run outs. Due to the fact that cold water will be circulated through the water mains, a sizeable movement of the water mains can be expected due to contraction. If for example, the piping is rigidly supported with no provision for movement, it is very possible that the tubing of fitting may be broken causing water leakage in the conditioned spaces throughout the building.

Coil Venting

Each standard basic unit coil is equipped with a manually operated air vent which is installed at the end of a small copper line leading into the highest point of the coil. By means of this valve, air may be vented manually, from the coil to keep it operating at full capacity. When water is first introduced into a coil, air is sometimes trapped in the coil tubing. This trapped air will reduce cooling capacity and create "Bubbling" or "Clanking" noise within the units. To release air trapped in the coil, press the air vent head to allow air to flow out of the air vent opening. Release when a steady stream of water appear.

Electrical Connection

As wiring regulations differ from country to country, please refer to your LOCAL ELECTRICAL CODES for field wiring regulations and ensure that they are complied with. Besides, take note of the following general precaution:

- 1) Ensure that the rated voltage of the unit corresponds to the name plate before commencing wiring work.
- 2) Provide a power outlet to be used exclusively for each unit and a power supply disconnect and a circuit-breaker for over-current protection should be provided in the exclusive line.
- 3) The unit must be EARTH to prevent possible hazards due to insulation failure.
- 4) All wiring must be firmly connected.

General Operation Guide

Start-Up

The following procedure must be completed before any attempts is made to put the entire system Into_operation:

- 1) Piping connections completed.
- 2) Electrical connections completed.
- 3) Duct connections completed.
- 4) Auxiliary drain pans in position where required.
- 5) Drain line draining into drain pans.
- 6) Filters correctly installed and free of construction debris.
- 7) Motor-blower assembly rotates freely.
- 8) Unit Hydro-statically tested and air vented.

Starting The Fan Coil Unit

- 1) Turn on the switch of water pump.
- 2) Start water chiller.
- 3) Operate the fan coil unit by turning on the fan and set the control switch to get the desired speed.
- 4) Inspect the duct and piping condition and rectify problem (e.g. vibration, noise, etc.) if exist.

Servicing And Maintenance

Fan coil units are designed to operate continuously with minor routine maintenance. Since fan coil units cool the discharging forced air, the efficiency with which the units operate is directly related to the amount of air passing through the coil.

Air Filters

The function of the air filters is to remove foreign matter such as dirt, soot, pollen and certain other impurities from the air passing through it. A clogged or dirty filter not only fails to do the job for which it is designed, but restricts the flow of air over the coil.

The importance of cleaning the filter before it becomes clogged must be greatly stressed. The frequency with which a filter should be cleaned will depend upon the amount of dust and foreign material that enters a unit, and this depends upon location and situation.

The washable viledon or saranet filter may be cleaned by tapping the filter on a solid surface to dislodge heavy particles. Wash under stream of warm water, with detergent if necessary. Dry it thoroughly before replacing.

Fan Motor

The fan motor is pre-lubricated and sealed at the factory. Therefore, no lubricating maintenance is required.

Coils

Clean coil unit by brushing between fins with a nylon brush. Brushing should be followed by cleaning with a vacuum cleaner. The coil may also be cleaned by using a high pressure air hose and nozzle if a compressed air source is available. It should be pointed out that if suitable air filter is used and taken care of properly, the coils need no cleaning.

Drain Pipe

The drain pipe should be checked before operation of unit is begun. If it is clogged, steps should be taken to clean the debris so that condensate will flow out easily.

Replacement Of Parts

Replacement of parts are available through your local dealers. When ordering parts, you must supply

- 1) Model name of the unit.
- 2) Serial number of the unit.
- 3) Part name and number.

