

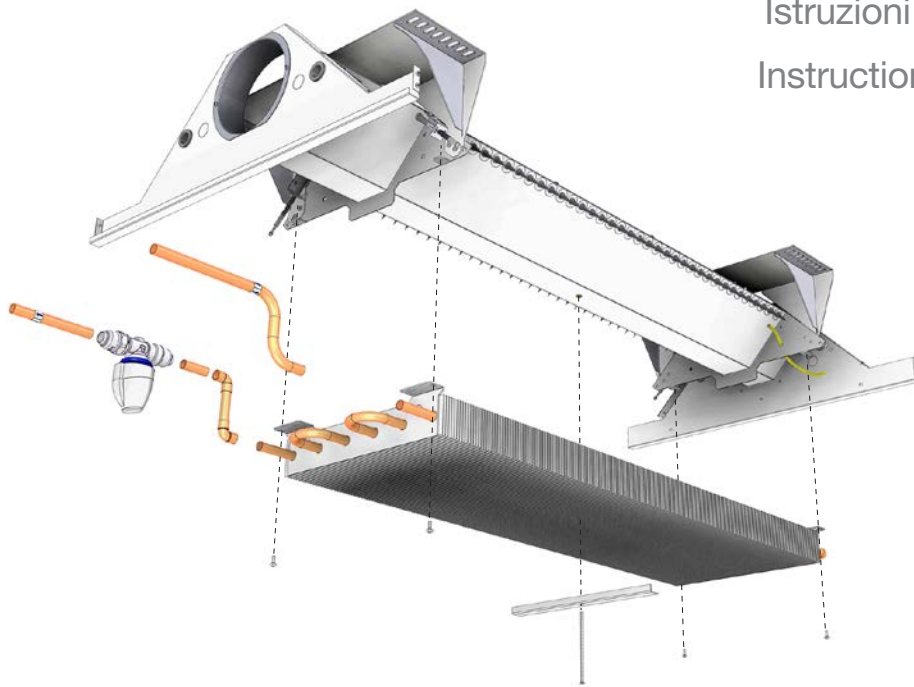

PREMIUM

Installation instruction
Installationsvejledning
Montageanvisning
Asennusohje
Montageanleitung
Istruzioni di montaggio
Instruction de montage





Premum

Dimensions
Dimensioner
Dimensioner
Mitat
Abmessungen
Dimensioni
Dimensions

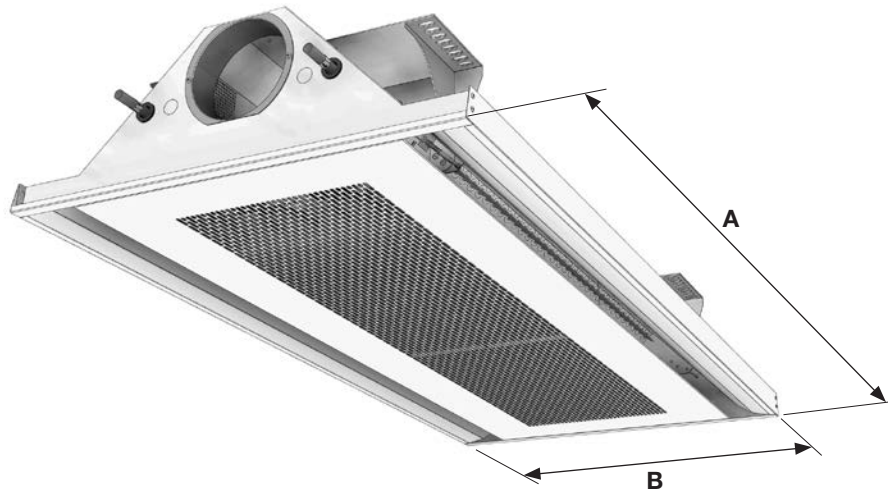

Premum is as standard delivered in steps of 0.1 m between 1.2 m -3.0 m.
 Premum leveres som standard i trin på 0,1 m mellem 1,2 m -3,0 m.
 Premum levereras som standard i steg på 0,1 m mellan 1,2 m -3,0 m.
 Premum vakiopituudet 1,2 - 3,0 m, jaotus 0,1 m.
 Premum wird als Standard in "Stufen" von 0,1 m zwischen 1,2 m -3,0 m geliefert.
 Premum is as standard delivered in steps of 0.1 m between 1,2 m -3,0 m.
 Premum est disponible en standard au pas de 0.1 m de 1,2 - 3m.

PREMUM	L (mm)	A (mm)	B (mm)	Kg / m
I-60	1200 - 3000 (steps of 100 mm)	1192 - 2992 (steps of 100 mm)	592	18
I-62	1200, 1800, 2400, 3000	1242, 1867, 2492, 3117	617	
X-60	1200 - 3000 (steps of 100 mm)	1199 - 2999 (steps of 100 mm)	599	

L = Nominal length (order length)

Symbols
Symboler
Symboler
Symbolit
Symbole
Simboli
Symbole



- UK** - Heavy Load - 2 man job. - It is recommended to use a "lift" for mounting.
- DK** - Tungt - 2 mands job. - Det anbefales at bruge en "lift" til montering.
- SE** - Tungt - 2 mans jobb. - Det rekommenderas att använda en "hiss" för montering.
- FI** - Raskas työ - 2 henkilöä. - On suositeltavaa käyttää asennusnostinta.
- DE** - Schwere Last - Arbeit für zwei Personen.
- Es wird empfohlen, einen „Lift“ für die Montage zu verwenden.
- IT** - Pesante carico - Manipolazione da parte di due persone.
- Si consiglia di utilizzare un "lift" per il montaggio.
- FR** - Charge lourde - manutention à 2 personnes - Utilisation d'une nacelle recommandée.



- UK** - Hot water
- DK** - Varmt vand
- SE** - Varmt vatten
- FI** - Kuuma vesi
- DE** - Heißes Wasser
- IT** - Acqua calda
- FR** - Eau chaude



- UK** - Cold water
- DK** - Koldt vand
- SE** - Kallt vatten
- FI** - Kylmä vesi
- DE** - Kaltes Wasser
- IT** - Acqua fredda
- FR** - Eau froide



Premum

Overview - Oversigt - Översikt - Yleiskatsaus - Übersicht - Panoramica - Aperçu

Ceiling systems - loftsystemer - Undertakssystem - Kattojärjestelmät - Deckensysteme Sistemi di controsoffitto - Systèmes de plafond

1.
21.

T24/T15 = 600 x 600
21 = 625 x 625

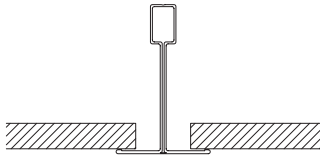

2.
22.

T24/T15 = 600 x 600
22 = 625 x 625

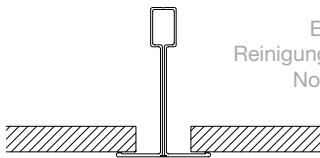

Not cleanable
Ej rensbar
Ej rensbart
Ei puhdistettava
Reinigung nicht möglich
Non ispezionabile
Non amovibile

3.

Permanent ceiling
Fast loft
Fast undertak
Kiinteä alakatto
geschlossene Decke
Soffitto permanente
Plafond non démontable



4.

Dampa Clip-in

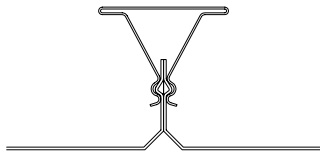

5.

Dampa Clip-in

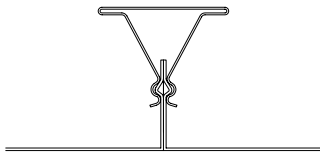

6.

Luxalon Clip-in

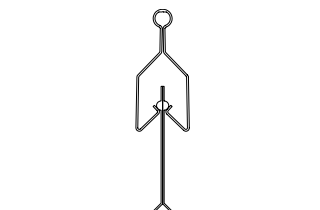

7.

Danotile Contur / Ecophon D
Rockfon D-XL

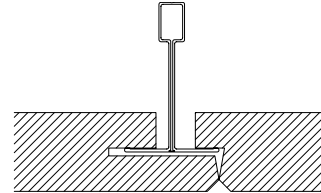

8.

Ecophon Focus DG

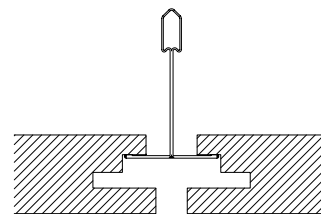

9.

Rockfon E10 24 / Ecophon E / T24

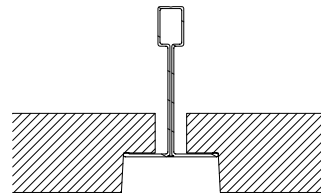

10.

Rockfon E10 15 / Ecophon E / T15

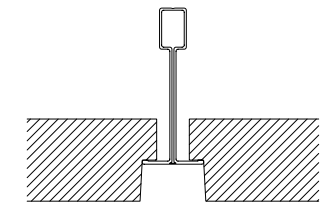

11.

Danotile Markant

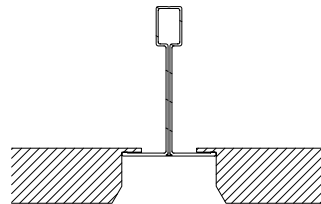

14.

Ecophon Focus DS

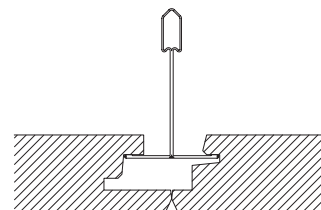



Premum

Possible connections - Supply air
 Mulige tilslutninger - Indblæsning
 Anslutningsmöjligheter - Tilluft
 Liitosvaihtoehdot - Tuloilma
 Anschlussmöglichkeiten - Zuluft
 Connessioni possibili - Mandata
 Connexions possibles - Soufflage

A, B, C, D

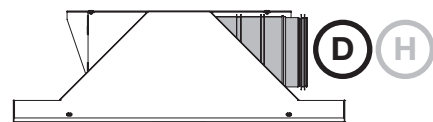
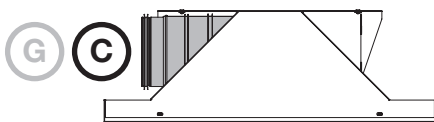
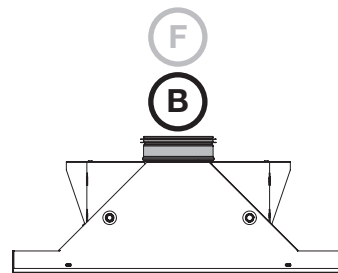
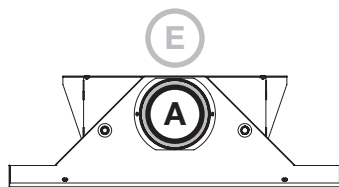
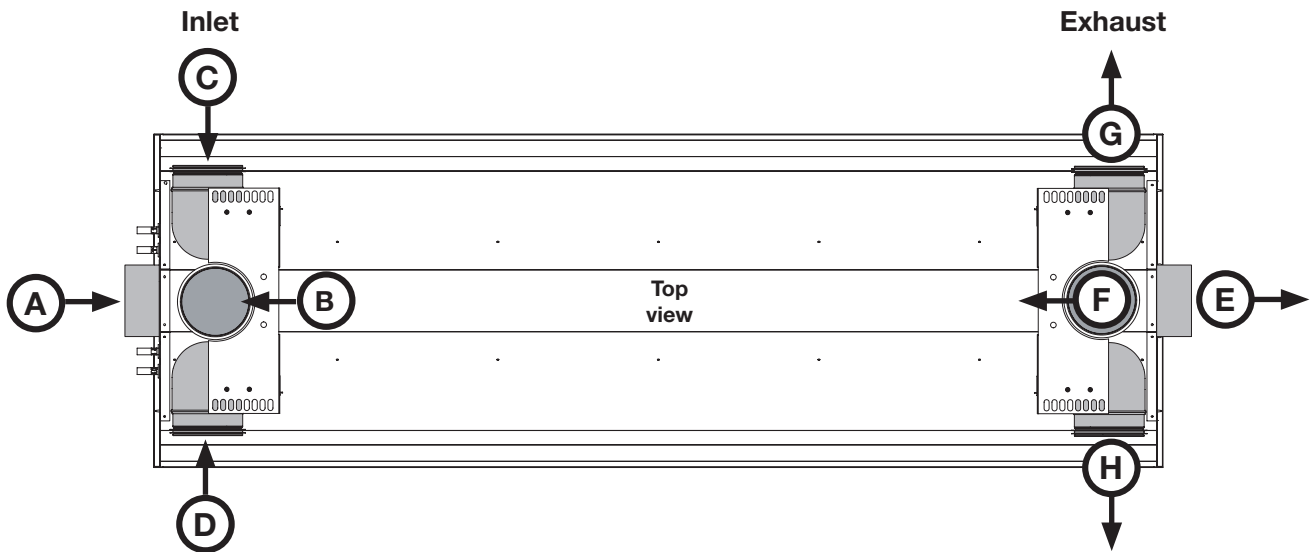

Premum standard with supply air - Can also be delivered with exhaust air.
 Premum standard kun med indblæsning - Kan også leveres med udsugning
 Premum standard med tilluft - kan även levereras med frånluft
 Premum vakiona tuloilma - Tilauksesta poistoilma
 Zuluftanschluss standard - Abluft optional
 Premum standard con attacco aria di mandata - Disponibile anche con attacco aria di ripresa
 Premum standard avec air neuf - Egalement disponible avec extraction.



Premum

Possible connections - Water
 Mulige tilslutninger - Vand
 Anslutningsmöjligheter - Vatten
 Liitosvaihtoehdot - Vesi
 Anschlussmöglichkeiten - Wasser
 Connessioni possibili - Acqua
 Connexions possibles - Eau

Cooling
 Køling
 Kyla
 Jäähdytys
 Kühlung
 Raffrescamento
 Froid

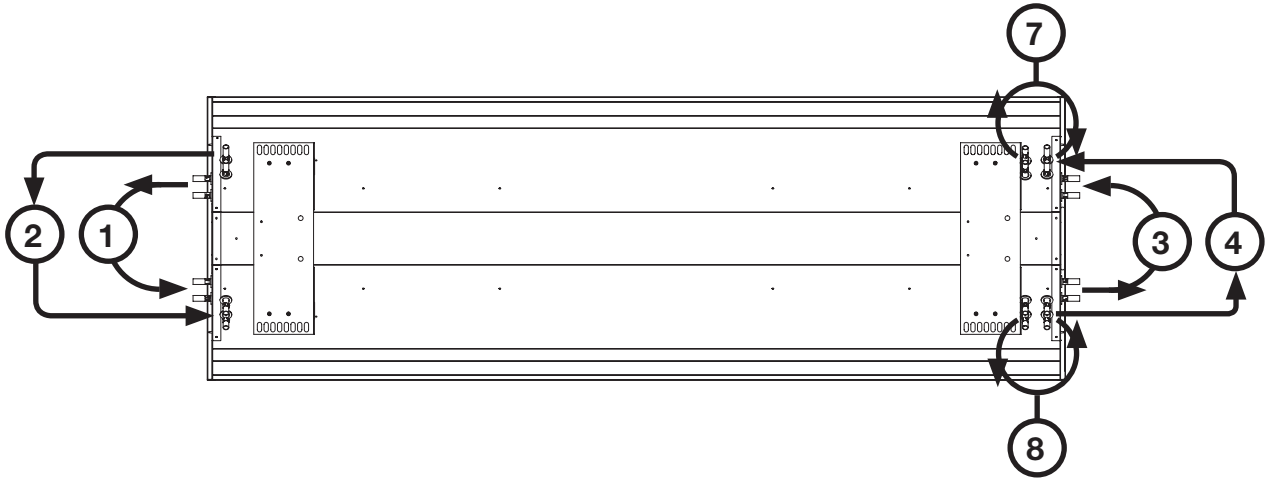
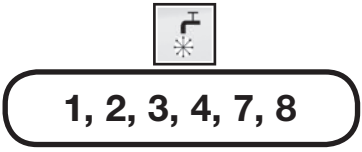

UK - Premum standard with cooling only - Can also be ordered with heating.
DK - Premum standard kun med køling - Kan også bestilles med varme.
SE - Premum standard med endast kyla - kan även beställas med värme.
FI - Premum vakiona vain jäähdytyksellä - Voidaan tilata myös lämmityksellä.
DE - Kühlung standard - Heizung optional.
IT - Premum standard con solo raffrescamento - riscaldamento opzionale.
FR - Premum standard froid seul - Egalement disponible avec fonction chauffage.

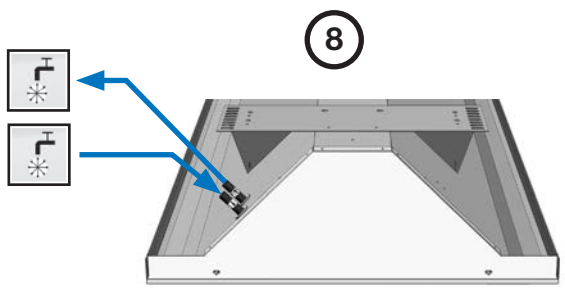
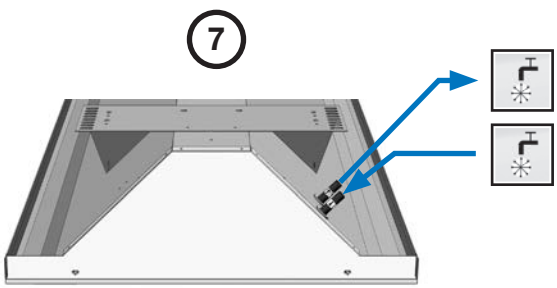
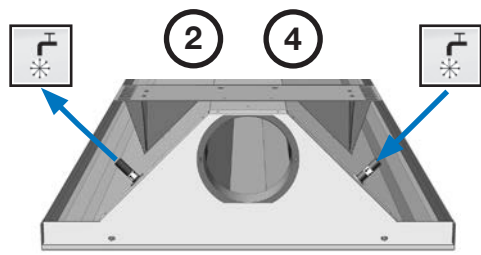
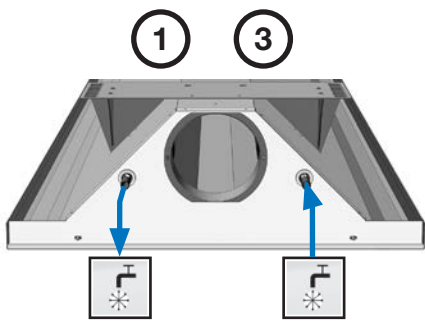



Premum

Possible connections - Water
 Mulige tilslutninger - Vand
 Anslutningsmöjligheter - Vatten
 Liitosvaihtoehdot - Vesi
 Anschlussmöglichkeiten - Wasser
 Connessioni possibili - Acqua
 Connexions possibles - Eau

Cooling / Heating
 Køling / Varme
 Kyla / Värme
 Jäähdytys / Lämmitys
 Kühlung / Heizung
 Raffrescamento / Riscaldamento
 Froid / Chaud

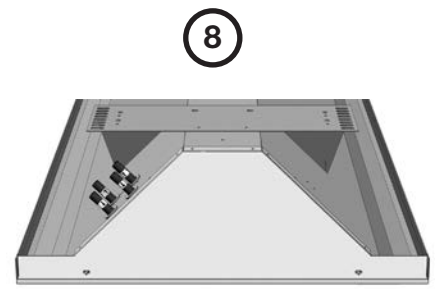
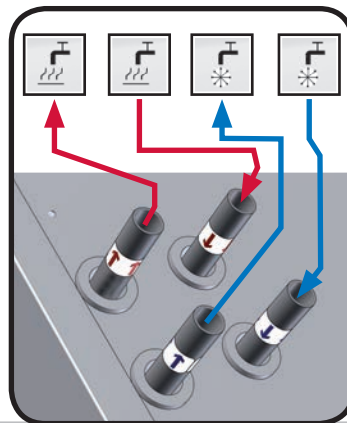
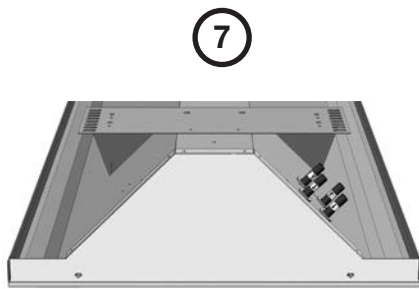
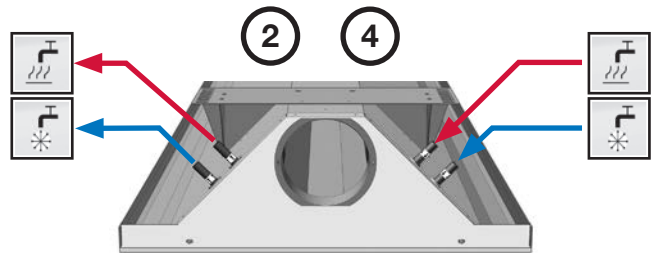
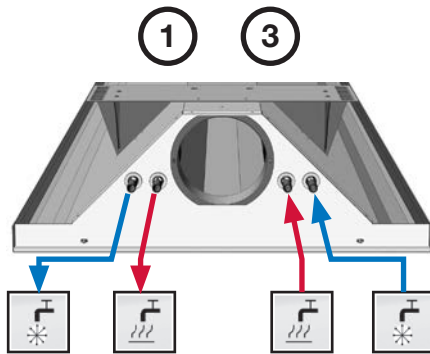
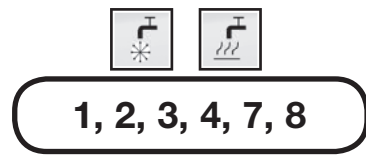

Possible combinations - Air / Water
 Mulige tilslutninger - Luft / Vand
 Anslutningsmöjligheter - Luft / Vatten
 Liitosvaihtoehdot - Ilma / Vesi
 Anschlussmöglichkeiten - Luft / Wasser
 Connessioni possibili - Aria / Acqua
 Connexions possibles - Air / Eau

- A: 1, 2, 3, 4, 7, 8
- B: 1, 2, 3, 4, 7, 8
- C: 3, 4, 7, 8
- D: 3, 4, 7, 8

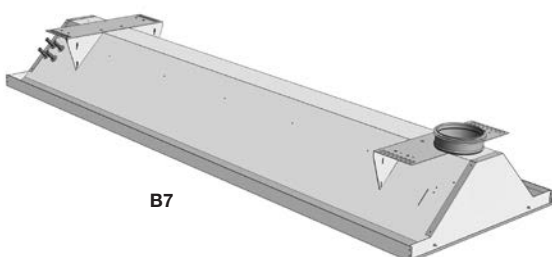

B7



A1



Premum

- Mounting accessories - Threaded rod M6**
- Montage tilbehør - Gevindstang M6**
- Installationstillbehør - Gängstång M6**
- Asennuslisävarusteet - Kierretanko M6**
- Montagezubehör - Gewindestange M6**
- Accessori di montaggio - Barre filettate M6**
- Accessoires de montage - Tiges filetées M6**

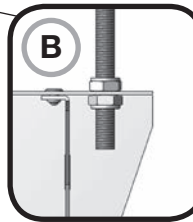
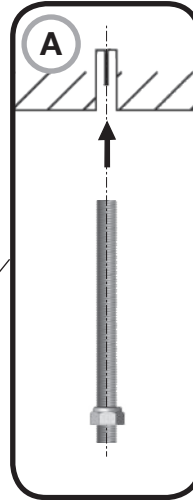
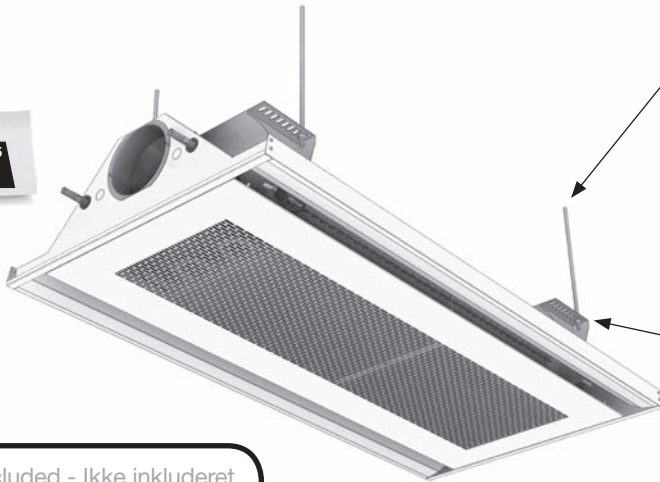

x4



M6
x4

Not included - Ikke inkluderet
Inte medföljande - Ei kuulu
Nicht enthalten - Non è incluso
- Non inclus

- Mounting accessories - MHS**
- Montage tilbehør - MHS**
- Installationstillbehør - MHS**
- Asennuslisävarusteet - MHS**
- Montagezubehör - Schnellspannhänger MHS**
- Accessori di montaggio - MHS**
- Accessoires de montage - MHS**

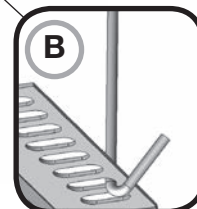
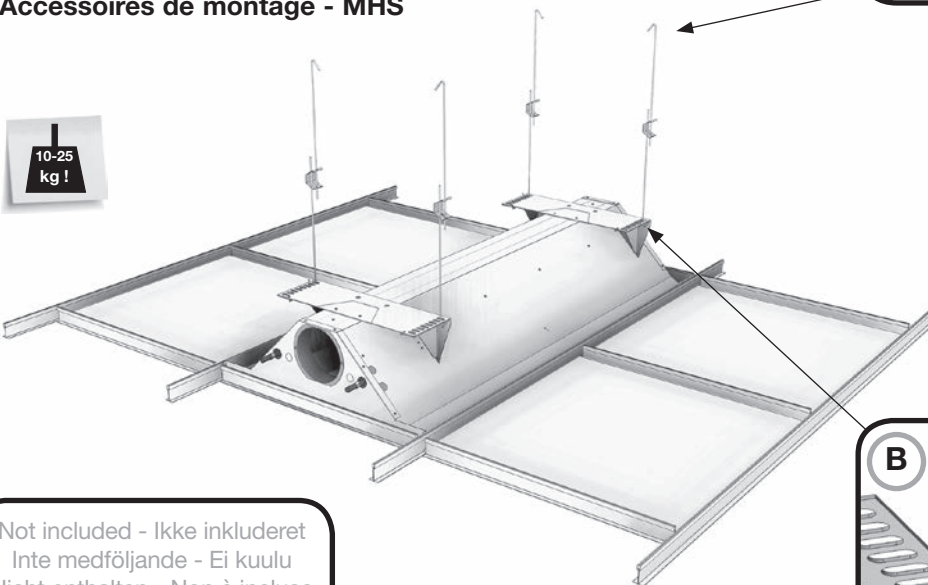

x4



MHS
x4

Not included - Ikke inkluderet
Inte medföljande - Ei kuulu
Nicht enthalten - Non è incluso
- Non inclus



Premum

Mounting in ceiling
Montage i loft
Montage i tak
Asennus alakattoon
Montage in der Zwischendecke
Installazione a soffitto
Montage en plafond

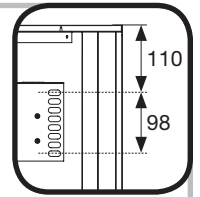

Premum I / X

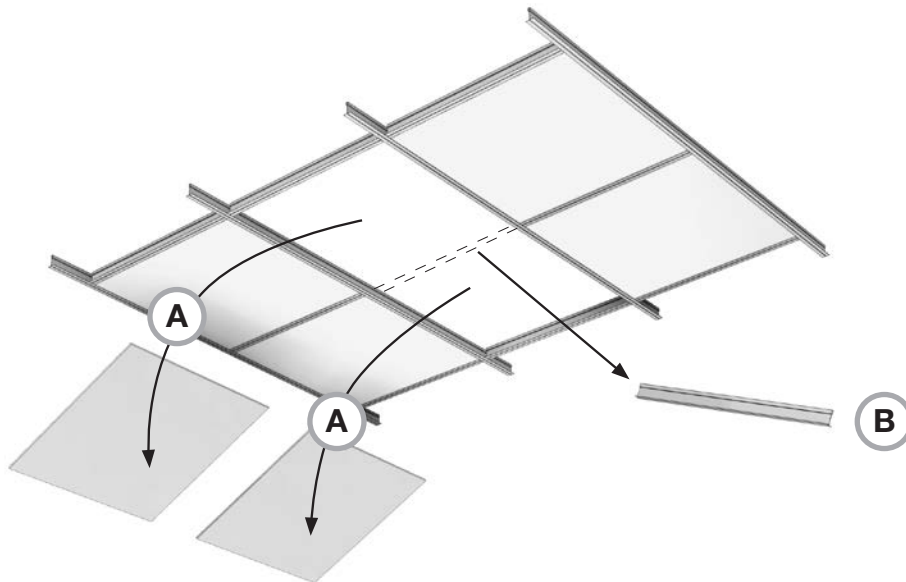
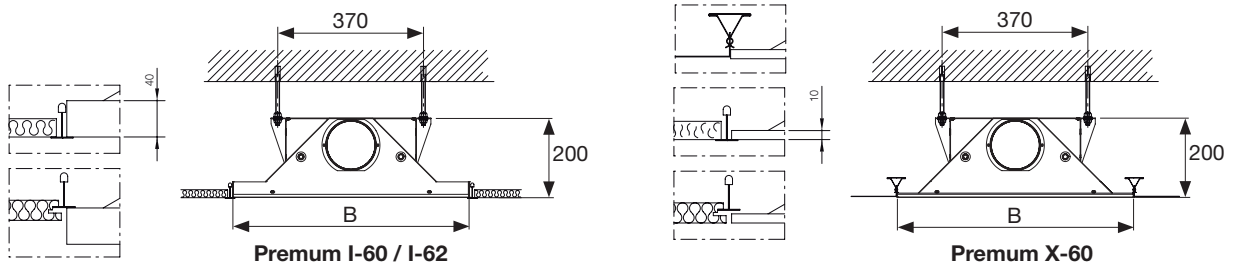

PREMUM	L (mm)	A (mm)	B (mm)	Kg / m
I-60	1200 - 3000 (steps of 100 mm)	1192 - 2992 (steps of 100 mm)	592	18
I-62	1200, 1800, 2400, 3000	1242, 1867, 2492, 3117	617	
X-60	1200 - 3000 (steps of 100 mm)	1199 - 2999 (steps of 100 mm)	599	

L = Nominal length (order length)



Premum

Opening face plate
 Åbne bundplade
 Fälla ned bottenplattan
 Etulevyn avaaminen
 Öffnen der Frontplatte
 Rimozione carter di
 copertura
 Ouverture façade

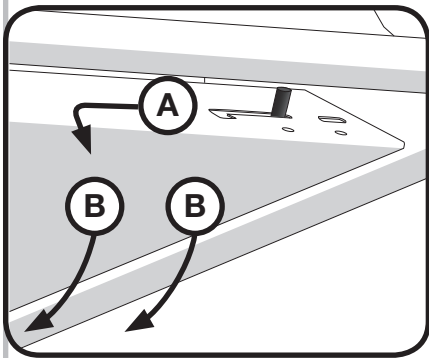
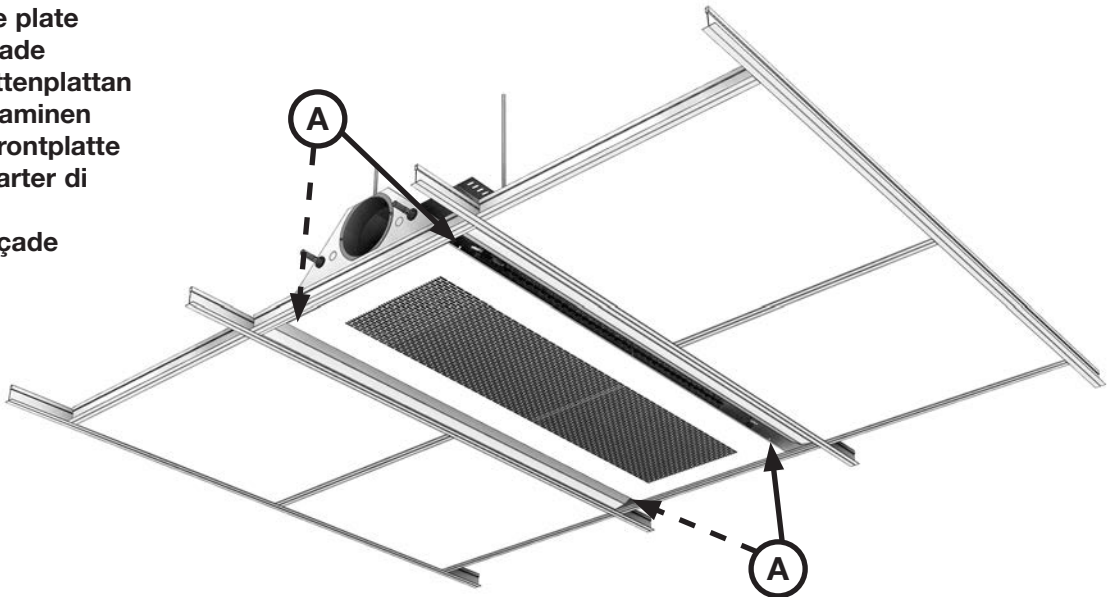

Service wire in one side of the faceplate, chosen by customer.
 service wire i en side af bundplade, valgt af kunde.
 Service vajer på ena långsidan av bottenplattan, kundval.
 Huoltovajeri toisella puolella etulevyä, asiakkaan määrittelemä.
 Service-Draht einseitig an Frontplatte - bauseitige Anpassung.
 Filo di servizio posizionato in un lato della piastra a scelta dell'utente.
 Câble de maintien sur un côté de la façade, précisé par le client.

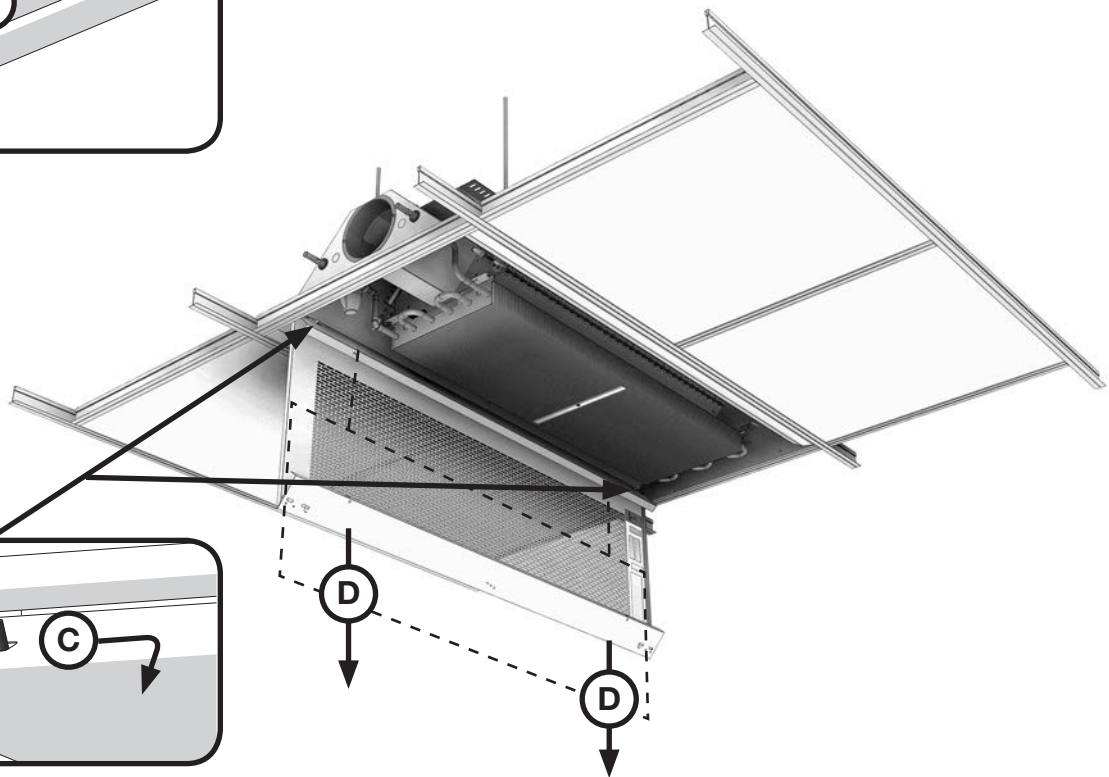
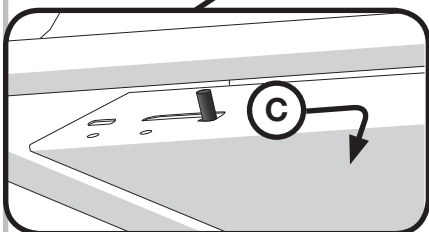

The faceplate now hangs in service wire, it can be removed completely when demounted from service wire.
 Frontpladen hænger nu i service wire, den kan fjernes helt, når den demonteres fra service wire.
 Bottenplattan hänger nu i service vajrarna, den kan plockas loss helt genom att demontera den från service vajrarna.
 Etulevy roikkuu nyt asennusvajereiden varassa. Etulevy voidaan poistaa myös kokonaan, jos se irrotetaan huoltovajereista.
 Frontplatte hängt an Service-Drähten - Frontplatte kann komplett demontiert werden.
 La piastra è ancorata al filo di servizio. La piastra può essere completamente rimossa sganciando il filo di servizio.
 La façade est maintenue par le câble de maintien, elle peut être retirée intégralement lorsque le câble de maintien est démonté.



Premum

JetCone 4 adjustment points
JetCone 4 justeringspunkter
JetCone 4 inusteringspunkter
JetCone säätöjärjestelmä

JetCone 4 Punkte Einstellung
JetCone 4 punti di regolazione
JetCone 4 points de réglage

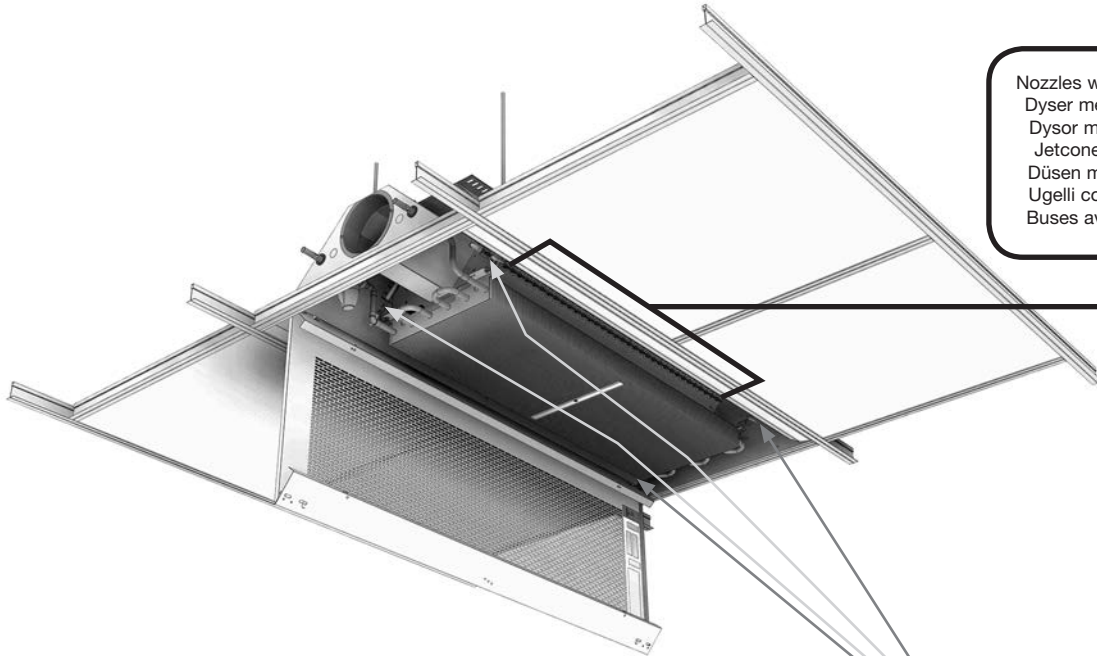

Nozzles with JetCones
 Dysor med JetCones
 Dysor med JetCone
 Jetcone suuttimilla
 Düsen mit JetCones
 Ugelli con JetCones
 Buses avec JetCone

Integrated adjustable nozzle unit
Integreret justerbar dyseenhed
Integrerad justerbar dysenhet
Säädettävä suutinyksikkö integroituna
Integrierte, einstellbare Düsenreihe
Sistema ad ugelli regolabili integrato
Système de buses ajustables intégré

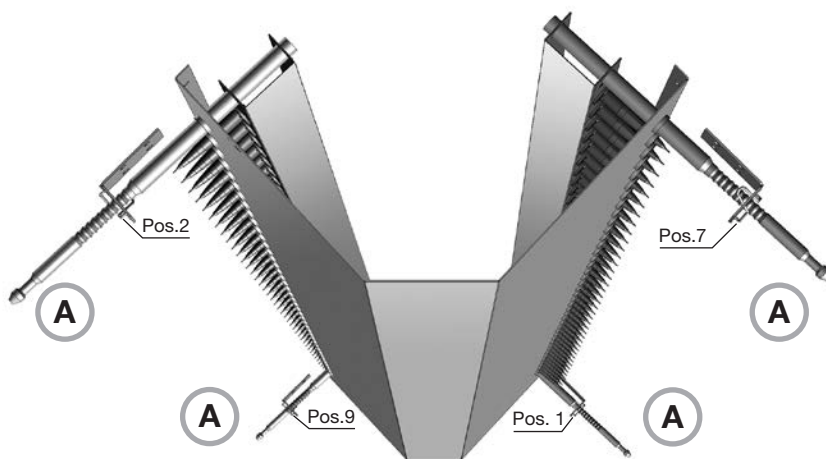

A

A

Adjustment pins
 Justeringsben
 Injusteringsreglage
 Säätötapit
 Einstellregler
 Perni di regolazione
 Barres d'ajustement

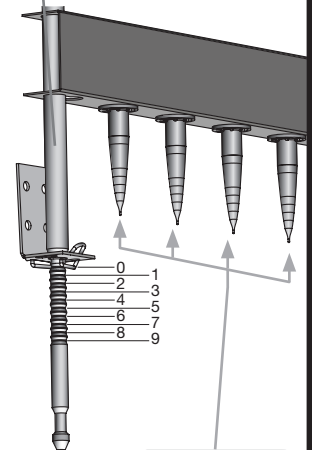

JetCones

Example - Asymmetrical pattern - When pins are in same position => symmetrical pattern.
Exempel - Asymmetrisk spredning - När justeringsben er i samme position => symmetrisk spredning.
Exempel - Asymmetrisk mönster - när reglagen är i samma position => symmetriskt mönster
Esimerkki - Epäsymmetrinen säätö - Kun säätötapit ovat samassa asennossa => symmetrinen säätö.
Beispiel - Asymmetrische Einstellung - Einstellregler in gleicher Position => Symmetrische Einstellung.
Esempio - Regolazione asimmetrica - Quando i perni sono nella stessa posizione => Regolazione simmetrica.
Exemple - Réglage asymétrique - Si les barres sont dans la même position => Réglage symétrique



Premum

JetCone 4 adjustment points
JetCone 4 justeringspunkter
JetCone 4 punti di regolazione
JetCone 4 injusteringspunkter
JetCone säätöjärjestelmä

JetCone 4 Punkte Einstellung
JetCone 4 punti di regolazione
JetCone 4 points de réglage

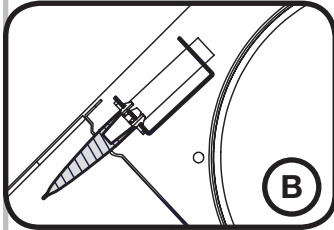

JetCone position
 JetCone position
 JetCone asento
 JetCone Position
 Posizione JetCone
 Position JetCone

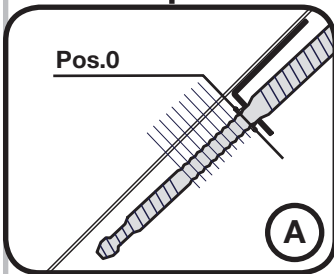
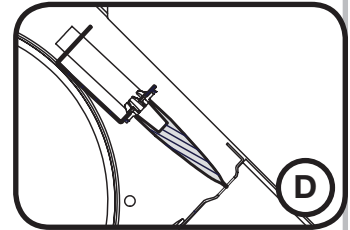

Adjustment pin position
 Justeringsben position
 Reglagepinnens position
 Säätötäpin asento
 Einstellregler Positionen
 Posizione di regolazione
 Position barre d'ajustement

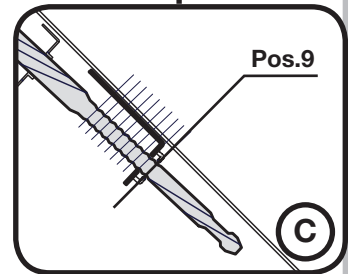

MAX. closed nozzle setting - 20% air flow.
 MAX. lukket dyse indstilling - 20% air flow.
 Max. stängd dysinställning - 20% luftflöde.
 Suutin kokonaan kiinni - 20 % ilmavirta.
 Pos. 0 - Min. geöffnet - 20% Luftmenge.
 MAX chiusura ugelli - 20% portata d'aria.
 MAX. fermeture de buses - 20% du débit.

MAX. open nozzle setting - 100% air flow.
 MAX. åben dyse indstilling - 100% air flow.
 Max. öppen dysinställning - 100% luftflöde.
 Avoin suutin - 100 % ilmavirta.
 Pos. 9 - Max. geöffnet - 100% Luftmenge.
 MAX apertura ugelli - 100% portata d'aria.
 MAX. ouverture de buses - 100% du débit.

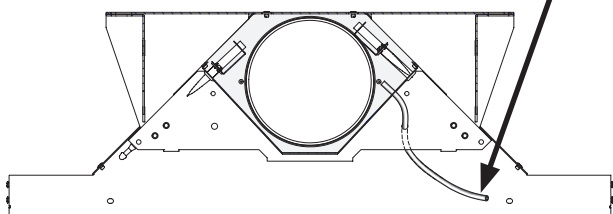
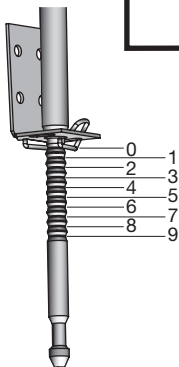
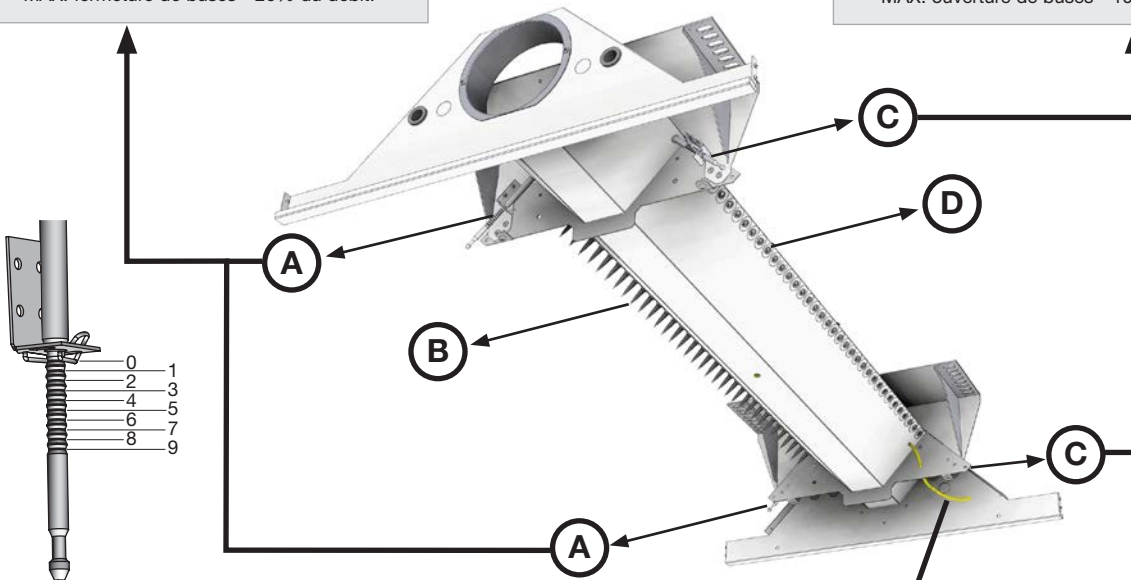

Measuring point
 mälepunkt
 Mätuttag
 Mittauspiste
 Meßpunkt
 Punto di misura
 Point de mesure



Premum

1.2 m < L ≤ 2.0 m

- JetCone 4 adjustment points
- JetCone 4 justeringspunkter
- JetCone 4 injusteringspunkter
- JetCone säätöpöytä
- JetCone 4 Punkte Einstellung
- JetCone 4 punti di regolazione
- JetCone 4 points de réglage

- Example
- Eksempel
- Exempel
- Esimerkki
- Beispiel
- Esempio
- Exemple

Premum
 $\Delta p_t = 80 \text{ Pa}$
 $q_a = 20 \text{ (l/s)}$

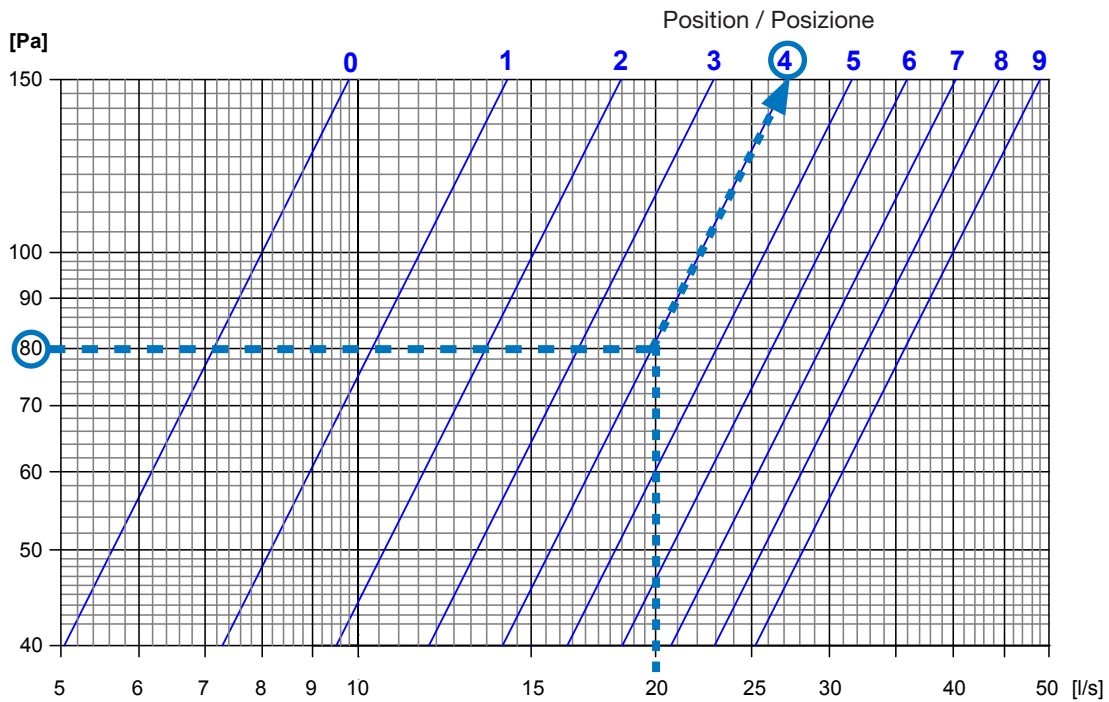

Symmetric adjustment
 Symetrisk indstilling
 Symmetrisk justering
 Symmetrinen säätö
 Symmetrische Einstellung
 Regolazione simmetrica
 Réglage symétrique

Asymmetric adjustment
 Asymetrisk indstilling
 Asymmetrisk justering
 Epäsymmetrinen säätö
 Asymmetrische Einstellung
 Regolazione asimmetrica
 Réglage asymétrique

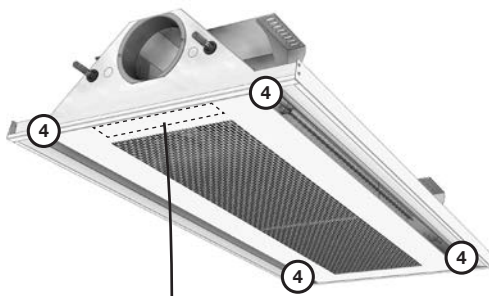

Keep average value as read in diagram (=4).
 Hold gennemsnitsværdi som aflæst i diagram (=4).
 Håll medelvärde som avläst i diagram (=4).
 Pidä keskiarvo samana kuin diagrammissa (=4).
 Mittelwert halten wie im Diagramm abgelesen (=4).
 Mantenere il valore medio come letto nel diagramma. (=4).
 Conserver la valeur moyenne lue dans le diagramme (=4).



Premum

2.0 m < L < 3.0 m

JetCone 4 adjustment points
 JetCone 4 justeringspunkter
 JetCone 4 injusteringspunkter
 JetCone säätöpiste
 JetCone 4 Punkte Einstellung
 JetCone 4 punti di regolazione
 JetCone 4 points de réglage

Example
 Eksempel
 Exempel
 Esimerkki
 Beispiel
 Esempio
 Exemple

Premum
 $\Delta p_t = 80 \text{ Pa}$
 $q_a = 25 \text{ (l/s)}$

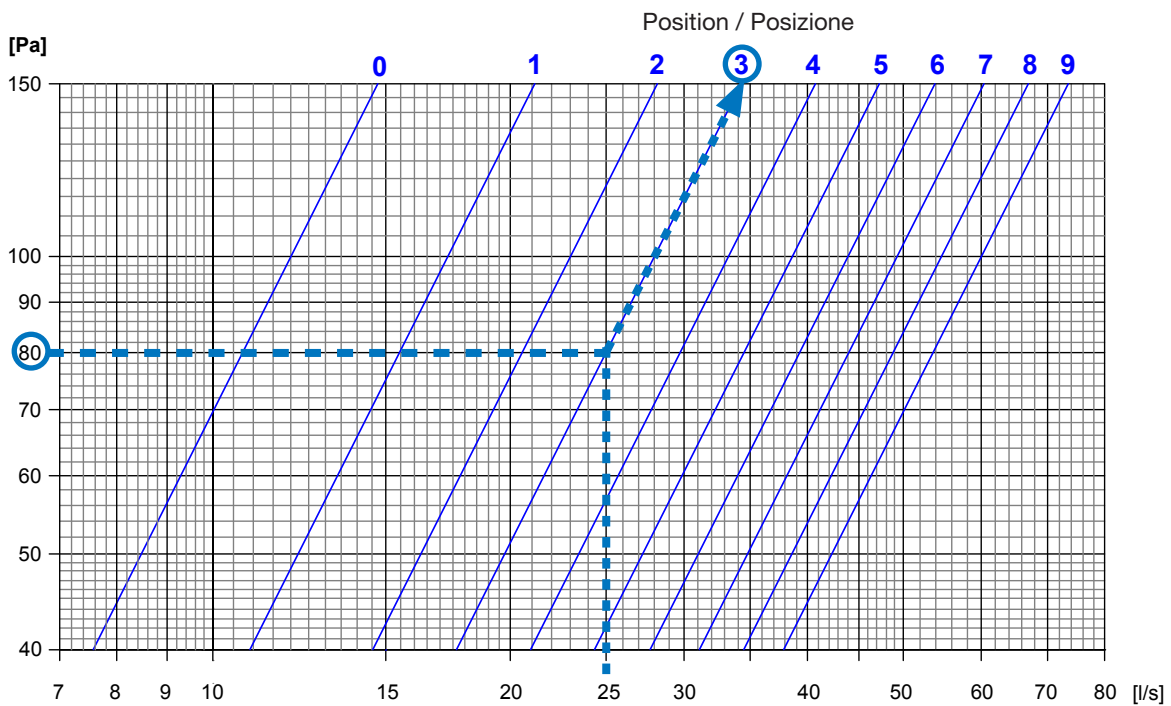

Symmetric adjustment
 Symetrisk indstilling
 Symmetrisk justering
 Symmetrinen säätö
 Symmetrische Einstellung
 Regolazione simmetrica
 Réglage symétrique

Asymmetric adjustment
 Asymetrisk indstilling
 Asymmetrisk justering
 Epäsymmetrinen säätö
 Asymmetrische Einstellung
 Regolazione asimmetrica
 Réglage asymétrique

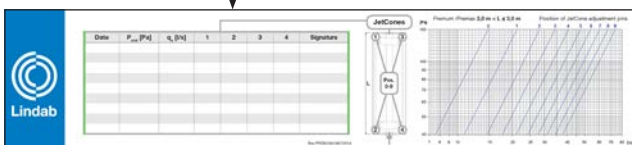
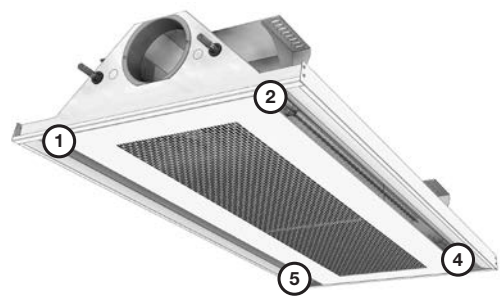
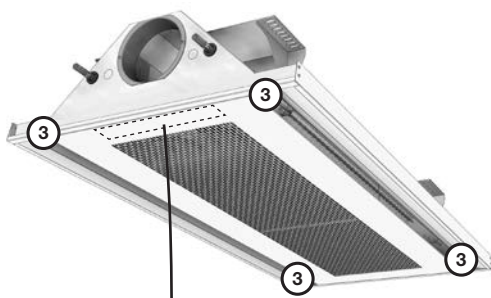

Keep average value as read in diagram (=3).
 Hold gennemsnitsværdi som aflæst i diagram (=3).
 Håll medelvärde som avläst i diagram (=3).
 Pidä keskiarvo samana kuin diagrammissa (=3).
 Mittelwert halten wie im Diagramm abgelesen (=3).
 Mantenere il valore medio come letto nel diagramma (=3).
 Conserver la valeur moyenne lue dans le diagramme (=3).



Premum

Adjustment of AirGuide system
Indstilling af AirGuide system
Inställning av AirGuide systemet
AirGuide-järjestelmän säätö
Einstellung des AirGuide Systems
Sistema di regolazione AirGuide
Ajustement du système Airguide

The faceplate include 4 seperate adjustable deflectors.
 Bundpladen har 4 seperate justerbare deflektore.
 Bottenplattan har 4 separata justerbara luftriktare.
 Etulevyssä on 4 erillistä säädettävää ohjainta.
 Die Frontplatte enthält 4 separate, einstellbare Luftlenkelemente.
 La piastra include 4 file di deflettori regolabili.
 La façade comprend 4 déflecteurs ajustables séparément.

A Each deflector has 2 adjustment "clips".
 hver deflektor har 2 justerings "clips".
 Varje luftriktare har 2 justerings "clips".
 Jokaisessa ohjaimessa on kaksi pidäkeklipsiä.
 Jedes Luftlenkelement ist mit zwei Klammern befestigt.
 Ogni deflettore ha 2 clips di regolazione.
 Chaque déflecteur a 2 clips d'ajustement.

Possible "clips" positions.
 Mulige "clips" positioner.
 Möjliga "clips" positioner.
 Mahdolliset pidäkeklipsien säätöasennot.
 Mögliche Einstellungen.
 Possibili posizionamenti delle clips.
 Positions possibles des clips.

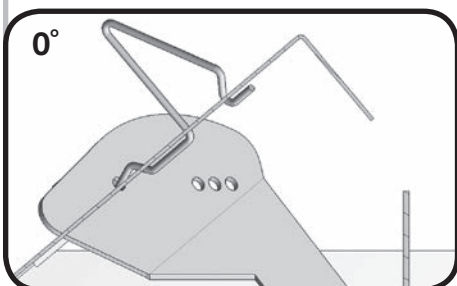
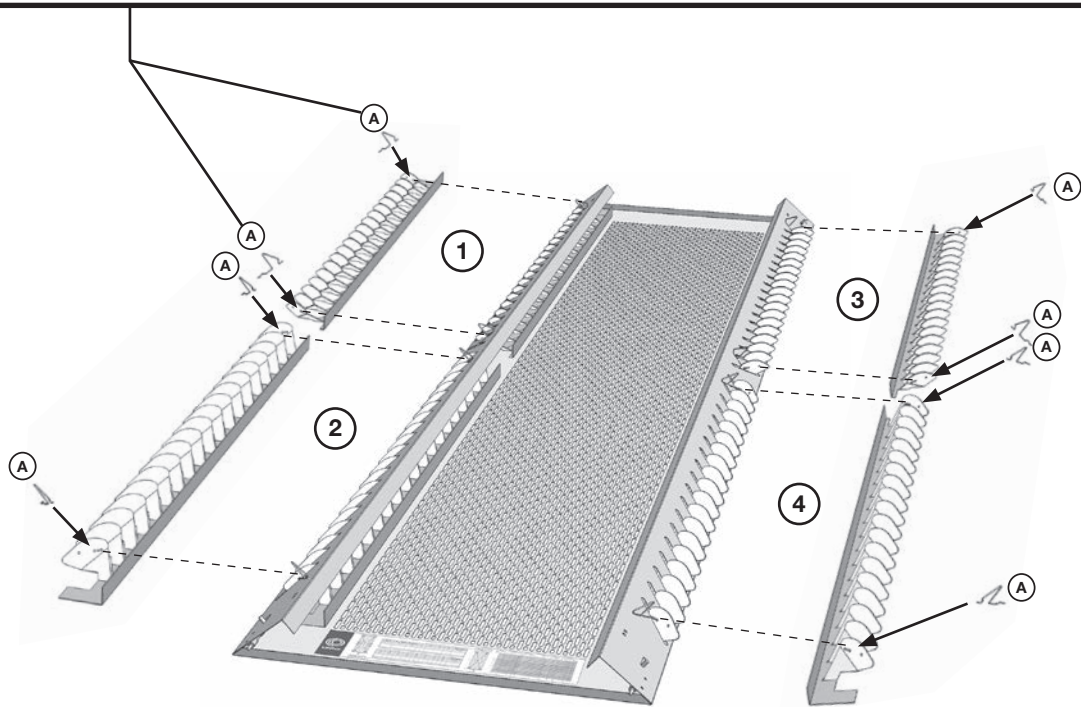
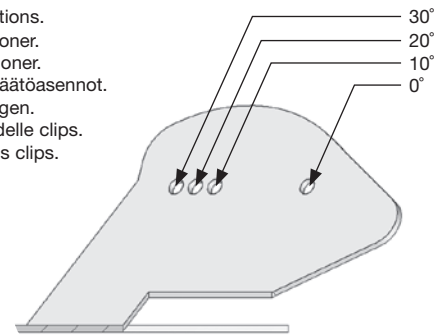
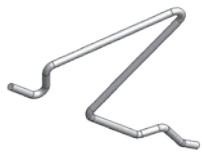

Example
 Eksempel
 Exempel
 Esimerkki
 Beispiel
 Esempio
 Exemple

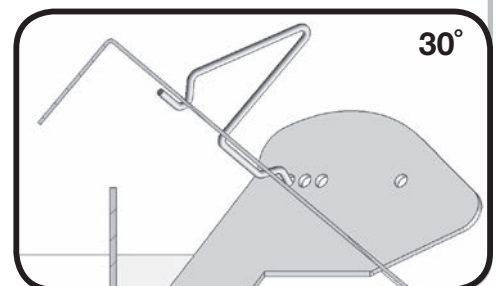



Premum

Reposition adjustment "clips"
Flyt justerings "clips"
Flytta justerings "Clips"
Pidäkeklipsin säätäminen
Verstellung der Luftlenkelemente
Riposizionamento delle clips di regolazione
Réglage des clips d'ajustement

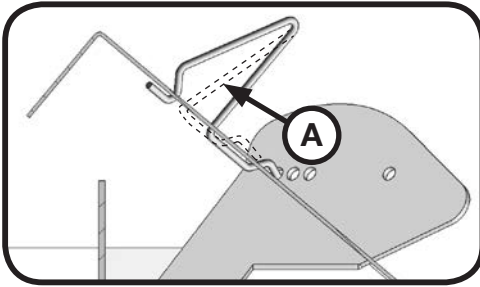

Press and release "clips" from deflector position.
 Tryk og frigør "clips" fra deflektor position.
 Tryck ihop och frisläpp Clipset från luftriktrarpitionen.
 Vapauta pidäkeklipsi ohjaimesta.
 Klammer zusammendrücken und aushaken.
 Premere e sganciare le clips dalla posizione corrente del deflettore.
 Pousser et relâcher les "clips" de la position défecteur.

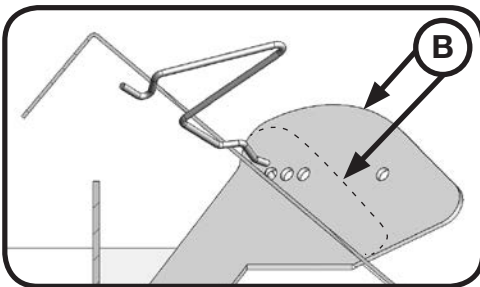

Align deflector at desired position.
 Tilpas deflektor til ønsket position.
 Sätt luftriktraren i önskad position.
 Säädä haluttuun asentoon.
 Luftlenkelement in gewünschte Position bringen.
 Regolare il deflettore nella posizione desiderata.
 Aligner le défecteur à la position souhaitée.

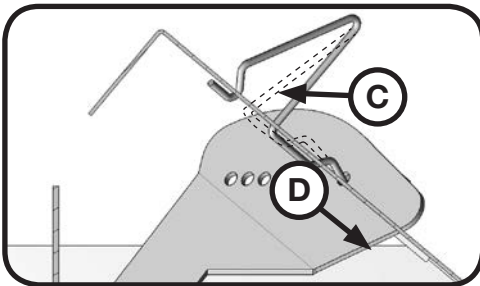

Press and release "clips" so it slips into new position.
 Tryk og slip "clips" så den glider ind i ny position.
 Tryck och släpp clipset så att det glider in i sin nya position.
 Kiinnitä pidäkeklipsi uuteen asentoon.
 Klammer zusammendrücken und Klammer wieder einhaken.
 Premere e rilasciare le clips nella nuova posizione.
 Pousser et relâcher les "clips" à la nouvelle position.

Recommended configurations
Anbefalede konfigurationer
Rekommenderade konfigurationer
Suosittelut säätöasennot
Emfohlene Einstellungen
Configurazioni raccomandate
Configurations recommandées

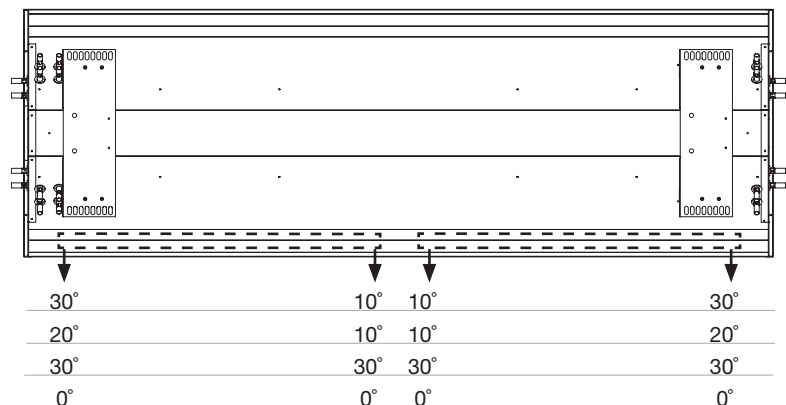

Support
Hjælp
Hjälp
Tuotetuki
Unterstützung
Supporto
Support

UK - Here you can find product updates/mounting instructions and support telephone number/mail.

www.lindab.com

Right to alterations reserved.

DK - Her kan du finde seneste produkt opdateringer/ montagevejledninger samt support tlf. nr/mail.

www.lindab.dk

Ret til ændringer forbeholdes.

SE - Här kan du alltid hitta senaste produktuppdateringarna/montageanvisningarna samt support tel. /e-mail.

www.lindab.se

Rätt till ändringar förbehålles.

FI - Täältä löydät uusimmat tuotetiedot ja asennusohjeet sekä tuotetuen yhteystiedot.

www.lindab.fi

Oikeus muutoksiin pidätetään.

DE - Hier finden Sie aktuelle Produktinformationen/ Montageanleitungen und Telefonnummer/ E-Mail-Adressen der Ansprechpartner.

www.lindab.de

Änderungen vorbehalten.

IT - Qui potete trovare istruzioni di montaggio, informazioni sul prodotto ed un supporto tecnico qualificato
Tel. 011 9952099 - e-mail: lindab@lindab.it

www.lindab.it

Soggetto a modifica senza obbligo di preavviso.

FR - Vous trouverez les fiches produits ou de montage actualisées ainsi que les coordonnées du support téléphonique à l'adresse suivante :

www.lindab.fr

Toutes modifications réservées.

Do you have trouble finding your local contacts please go to:

www.lindab.com

PREMUM-10072014



www.lindab.com